

**Safeguard your systems
from electrical turbulence**



U-POWER
OMEGA
Air Circuit Breakers

Stabilise systems with technology.



Electrical power is the lifeline of industry, but it is unpredictable. Just like an ocean, it can be calm one moment and turbulent the next. You cannot predict when a sudden dip or surge will happen, but you can protect your installation from damage, when it does. That's where our highly sophisticated OMEGA ACBs can make a world of difference to the safety of an organisation's employees, systems and infrastructure.

OMEGA ACB range consists of highly compact units designed for high current, high power applications in Low Voltage (LV) distribution network systems. They are equipped with state-of-the-art Matrix protection and control releases to meet the most demanding protection and system co-ordination requirements. All this, with the assurance of compliance to the L&T Electrical & Automation 'Safe & Sure' policy.

**Awarded 'Overall Best Product
by an Indian Exhibitor'
at ELECRAMA**

U-POWER
OMEGA
Air Circuit Breakers

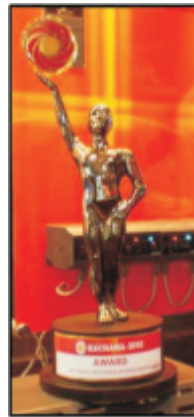

L&T Electrical & Automation (E&A) -The bedrock of stability.

Over the last five decades, E&A has earned a place among the leading manufacturers of Low Voltage Switchgear in the world, with the scale, sophistication and range to meet global benchmarks.

In keeping with our leadership position in the Indian market, we also provide expert assistance in product selection, installation and effective after-sales service, across the country.

Change course quickly.



The OMEGA ACB range has been designed to adapt to changes in your requirements, and allow you to modify or upgrade your systems with ease. This means minimum down-time and enhanced protection at all times.

Get the OMEGA advantage

- **Meet system upgradation needs** with ease throughout the life of your product, with click-fit, easy-to-mount front accessories like U/V and U/V delay modules, Shunt and Closing releases.
- **Enjoy total system flexibility and scalability** by adding power metering and communication modules or by enabling/disabling each protection function, depending on the requirement.
- **Let your systems have better co-ordination** with protection devices and downstream loads, via a wide range of protection curves and fine adjustment of current pick-up threshold and time-delay settings.
- **Control a vast electrical installation** through Zigbee communication, along with the option of conventional industrial communication protocols such as MODBUS and PROFIBUS.
- **Customise terminals** by configuring terminal adaptors for Vertical/Horizontal busbar arrangements, to facilitate termination of Aluminium and Copper busbars. Refer page No. 127-129 for recommended busbar sizes for termination.
- **Convert ACBs easily on site** from Fixed to Draw-out or from Manual to Electrical versions.





Match performance with prudence.



OMEGA ACBs offer you the best of both worlds – high performance coupled with a range of exclusive features that deliver the highest level of electrical safety.

Performance par excellence

- **Save valuable space** with world's most compact ACBs, starting at just 347mm in width.
- **Enjoy total reliability** in even the harshest of conditions including high ambient temperatures and humidity levels.
- **Savour operational flexibility**, as the ACB discriminates between fault zones selectively, allowing downstream equipment to clear the fault in a prescribed time before intervening.

Negating human error with safety features

- **No Arc-chute, No closure:** Unique features like Arc-chute Interlocking and True Ready-to-Close (RTC) detection systems ensure that the ACB closes only when the Arc-chutes are in place and all other pre-requisite conditions are fulfilled.
- **Power ON, No racking operation:** An inbuilt Smart racking-shutter ensures that the ACB is racked-in/out only in 'OFF-state'.
- **One signal, One closure:** An inbuilt Electrical and Mechanical Anti-pumping System cancels the persistent closing signal after successful ACB closure.
- **No unauthorised setting changes:** An innovative Password Protection feature ensures that only authorised personnel can change the release settings.



Adopt technological brilliance.



OMEGA ACBs are loaded with superior technology, across three frame sizes for the entire current range from 400A to 6300A. These features, including systems for communication, control and protection (Matrix), make these ACBs a dream to use.

OMEGA ACBs allow you to:

- **View** a snapshot of all parameters and symptoms through a user-friendly, state-of-the-art O-LED Display.
- **Control** the system parameters of vast installations easily, with a special Smart-card feature and user-friendly Touch-Screen Display.
- **Manage** energy consumption better by monitoring various energy parameters such as phase components, power factors, energy and maximum demand.
- **Communicate** between system elements wirelessly and stay informed at all times through mobile alerts.
- **Add and remove** Arc-chutes and various Volt-metric releases easily, without the need for tools.
- **Upgrade** systems for safety, protection, control and monitoring with a wide range of accessories and safety interlocks for versatile applications.
- **Enjoy** the benefit of total system compliance with all the relevant quality, safety and environmental standards.

E&A's wide range of Electrical Standard Products includes powergear, controlgear, energy management devices, building electrical and automation products – each of which matches and exceeds global benchmarks for reliability and quality. However, in order to ensure that your business sails smoothly through any electrical turbulence, every element must be in perfect working condition.

At E&A, we offer you the benefit of five decades of experience in providing After-Sales Service for Low Voltage Distribution Systems in every type of industry and building in India.

The E&A Service Advantage

- **Preventive Maintenance:** Advice is provided and preventive checks carried out on a regular basis.
- **Service On Call:** A network of over 100 approved Service Centres across India ensures that service is just a phone call away.
- **Annual Maintenance Contract:** Comprehensive care for your systems including Obsolescence Management and Part Replacement, as deemed necessary.
- **Obsolescence Management:** We offer spares and retro-fitment services, including upgrading all L&T Switchgear, to ensure that your systems run smoothly.
- **Training on Product Usage:** Our service engineers work with customers' maintenance staff to train



Keep an eye on upkeep.



Special Applications-

800V AC/1000V AC Rated Voltage Applications:

Specially designed OMEGA ACB range offers a solution for electrical applications with system voltages of 800V and 1000V AC. This range of ACBs maintain the same dimension and accessories as the standard 690V AC range. This range of ACBs is available with LSI and LSING Protections through following Microprocessor Releases -

- 1) MTX1.0 - LSI Protection
- 2) MTX1G - LSING Protection
- 3) MTX1.5G - LSING Protection with Current Metering
- 4) MTX1Gi - LSING Protection with Inbuilt ZSI
- 5) MTX1.5Gi - LSING Protection with Current Metering & Inbuilt ZSI
- 6) MTX3.5 & Above - LSING Protection with Current Metering & optional / Inbuilt Communication
(Please contact Our Sales Office for details about available advance Measurement / Protection & Features).

This Range of ACBs available for Current Ratings 400A-6300A in N Version therefore it offers
 $I_{cu}=I_{cs}=I_{cw} (1Sec) = 50kA.$

NOTE:

Please contact our nearest Sales Office for further technical and ordering details.

To find the perfect OMEGA ACB to protect your systems from electrical turbulence, turn the page.



U-POWER

OMEGA

Air Circuit Breakers



INDEX

13

Air Circuit Breakers

25

Matrix Protection & Control Units

69

Accessories

83

Control Circuit Wiring

91

Mounting & Termination

132

ACB Ordering Information

U-POWER

OMEGA

Air Circuit Breakers

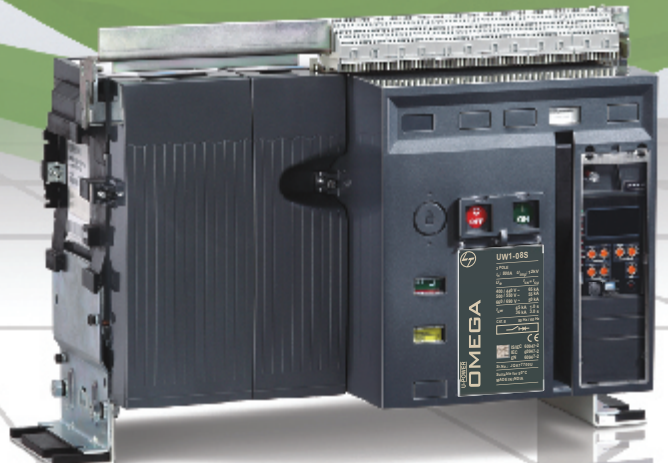

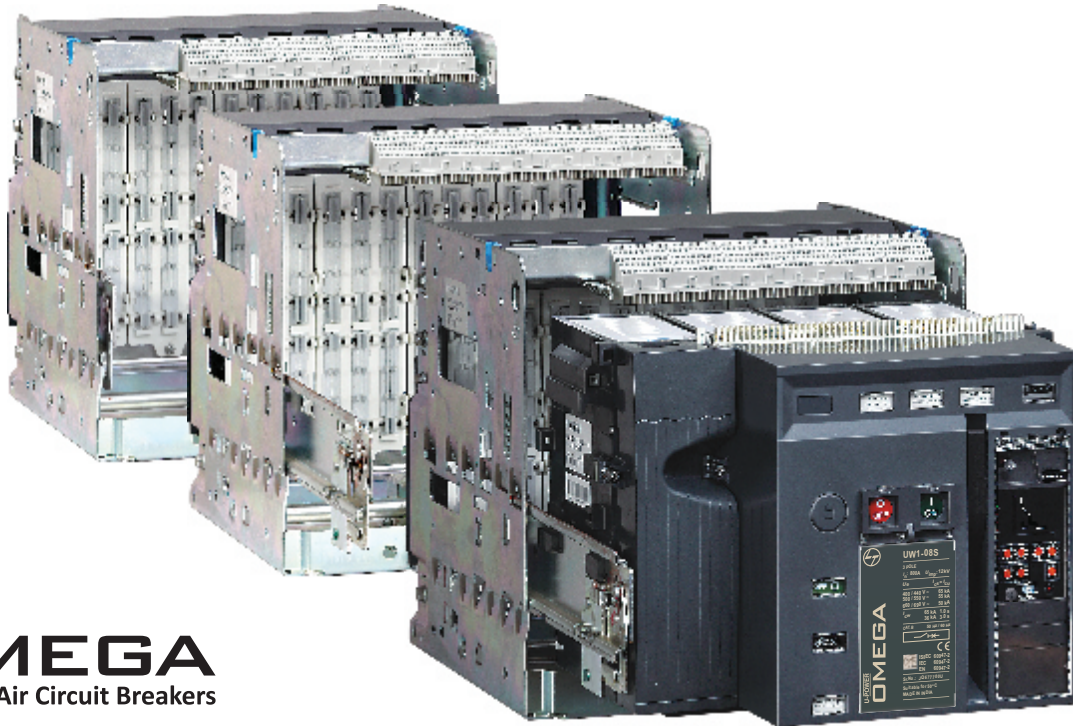

U-POWER
OMEGA
Air Circuit Breakers

- Complete range conforms to IS/IEC 60947-2 & IEC 60947-2
- Current rating from 400A to 6300A in 3 frame sizes
- Available in 3 Pole/4 Pole, Manually & Electrically operated, Fixed & Draw-out versions
- Common Height & Depth across the range
- High short-time fault withstanding capacity, $I_{cu} = I_{cs} = I_{cw}$ for 1 sec for total selectivity
- High mechanical and electrical operating life
- Modular & snap-fit accessories
- Ease of on-site conversion from Fixed to Draw-out & Manual to Electrical versions
- Best in class Termination overlap with Bus bars.
- RoHS compliant

Breaking Capacities: $I_{cu} = I_{cs} = I_{cw}$

Rated current	800A	1000A	1250A	1600A	2000A	2500A	3200A	4000A	5000A	6300A	
Frame-1	N : 50kA	✓	✓	✓	✓	✓					
	S : 65kA	✓	✓	✓	✓	✓					
	H : 80kA	✓	✓	✓	✓	✓					
		UW1-08	UW1-10	UW1-12	UW1-16	UW1-20	UW1-25				
Frame-2	N : 50kA	✓	✓	✓	✓	✓	✓	✓	✓	✓	
	S : 65kA	✓	✓	✓	✓	✓	✓	✓	✓	✓	
	H : 80kA	✓	✓	✓	✓	✓	✓	✓	✓	✓	
		UW2-08	UW2-10	UW2-12	UW2-16	UW2-20	UW2-25	UW2-32	UW2-40		
Frame-3	H : 80kA	✓	✓	✓	✓	✓	✓	✓	✓	✓	
	V : 100kA	✓	✓	✓	✓	✓	✓	✓	✓	✓	
		UW3-08	UW3-10	UW3-12	UW3-16	UW3-20	UW3-25	UW3-32	UW3-40	UW3-50	UW3-63

Note: 400A & 630A versions also available.

Circuit Breaker upto 690V AC :

Frame				1					2			3				
Rated Uninterrupted Current (In) (A) at 50° C				400-2000			2500 ⁽¹⁾		400-4000 ⁽²⁾			400-5000		6300 ⁽³⁾		
Version				N	S	H	S	H	N ⁽⁴⁾	S	H	H	V	H	V	
Rated Operational Voltage at 50/60 Hz.		Ue		upto 690V AC												
Rated Insulation Voltage at 50/60 Hz.		Ui		1000V AC												
Rated Impulse withstand Voltage		Uimp		12kV (Main Circuit) & 4kV (Auxiliary Circuit)												
Suitability for Isolation				Yes												
Degree of Protection on Breaker front				IP53 Standard, IP54 Optional												
Degree of Impact Protection on Breaker front				IK08 Standard, IK10 Optional												
Pollution Degree Suitability				4												
Utilization Category				B												
Compliance				IS / IEC 60947 (Part-2), EN 60947-2, IEC 60947-2												
Operational Temperature Range (As per IEC 60068-2-1/IEC 60947-1-Q)				-25°C to 70°C												
Storage Temperature Range (As per IEC 60068-2-1/2)				-40°C to 85°C												
Rated Ultimate S.C. Breaking Capacity	Icu (kA)	415/440V AC		50	65	80	65	80	50	65	80	80	100	80	100	
		500/550V AC		42	55	65	55	65	42	55	70	70	85	70	85	
		660/690V AC		36	50	55	50	55	36	50	65 ⁽⁵⁾	65	75	65	75	
Rated Service S.C. Breaking Capacity	Ics (kA)	415/440V AC		100% Icu												
		500/550V AC														
		660/690V AC														
Rated Short-time Withstand Capacity	Icw (kA)	0.5sec		50	65	80	65	80	50	65	80	80	100	80	100	
		1.0sec		50	65	80	65	80	50	65	80	80	100	80	100	
		3.0sec		26	36	44	36	44	26	44	50	65	75	65	75	
Rated S.C. Making Capacity	Icm (kA)	415/440V AC		105	143	176	143	176	105	143	176	176	220	176	220	
		500/550V AC		88	121	143	121	143	88	121	154	154	187	154	187	
		660/690V AC		76	105	121	105	121	76	105	143 ⁽⁶⁾	143	165	143	165	
Break Time (ms)		25														
Closing Time (ms)		60														
Mechanical Life ⁽⁷⁾		With Routine maintenance		20000					15000			10000				
Electrical Life ⁽⁷⁾		With Specific maintenance		20000					15000			10000				
		With Routine maintenance		10000			5000		5000			5000		2000		
Dimensions	Fixed ACB	W (mm)	Width 3P	347					447			647				
			Width 4P	447					581			847				
		D (mm)	Depth	324									334			
			H (mm)	Height	430											
	Draw-out ACB	W (mm)	Width 3P	347					447			647				
			Width 4P	447					581			847				
		D (mm)	Depth	421									431			
			H (mm)	Height	433											

(1) Please consult branch office for selection

(2) Frame-2 4000A available in S & H Version only

(3) Rated Uninterrupted Current (In) (A) at 40°C

(4) Available till 3200A

(5) 65kA upto 3200A & 55kA for 4000A

(6) 143kA upto 3200A & 121kA for 4000A

(7) Value corresponds operating cycle

Refer Users' Manual for Routine/Specific maintenance

Circuit Breaker 800V AC & 1000V AC :

Frame			1	2	3	2		
Rated Uninterrupted Current (In) (A) at 50° C			400-2000	400-3200	400-6300	400-3200		
Version			N08			N10		
Rated Operational Voltage at 50/60 Hz.	Ue	800V AC			1000V AC			
Rated Insulation Voltage at 50/60 Hz.	Ui	1000V AC			1250V AC			
Rated Impulse withstand Voltage	Uimp	12kV (Main circuit) & 4kV (Auxiliary circuit)						
Suitability for Isolation			Yes					
Degree of Protection on Breaker front			IP53 Standard, IP54 Optional					
Degree of Impact Protection on Breaker front			IK08 Standard, IK10 Optional					
Pollution Degree Suitability			4					
Utilization Category			B					
Compliance			IS / IEC 60947 (Part-2), EN 60947-2, IEC 60947-2					
Operational Temperature Range <small>(As per IEC 60068-2-1/IEC 60947-1-Q)</small>			-25°C to 70°C					
Storage Temperature Range <small>(As per IEC 60068-2-1/2)</small>			-40°C to 85°C					
Rated Ultimate S.C. Breaking Capacity	Icu (kA)	800V AC	50			50		
		1000V AC	-			50		
Rated Service S.C. Breaking Capacity	Ics (kA)	800V AC	100% Icu			100% Icu		
		1000V AC	-			100% Icu		
Rated Short-time Withstand Capacity	Icw (kA)	0.5 sec	50	50	50			
		1.0 sec	50	50	50			
		3.0 sec	36	50	50			
Rated S.C. Making Capacity	Icm (kA)	800V AC	105			105		
		1000V AC	-			105		
Break Time (ms)		25			25			
Closing Time (ms)		60			60			
Mechanical Life ⁽¹⁾	With Routine maintenance		20000	15000	10000	15000		
Electrical Life ⁽¹⁾	With Specific maintenance ⁽²⁾		20000	15000	10000	15000		
	With Routine maintenance		1000	1000	1000	500		
Dimensions	Fixed ACB	W (mm)	Width 3P	347	447	647	447	
			Width 4P	447	581	847	581	
		D (mm)	Depth	324			334	324
			H (mm)	Height	430			
	Draw-out ACB	W (mm)	Width 3P	347	447	647	447	
			Width 4P	447	581	847	581	
		D (mm)	Depth	421			431	421
			H (mm)	Height	433			

(1) Value corresponds operating cycle

(2) With necessary component replacement

Circuit breaker upto 690V AC:

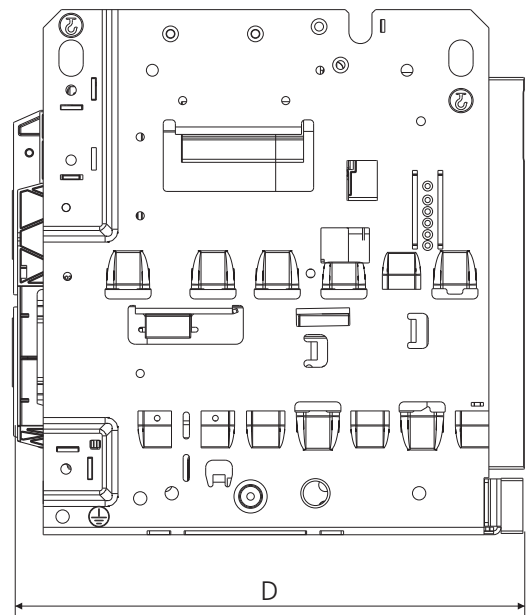
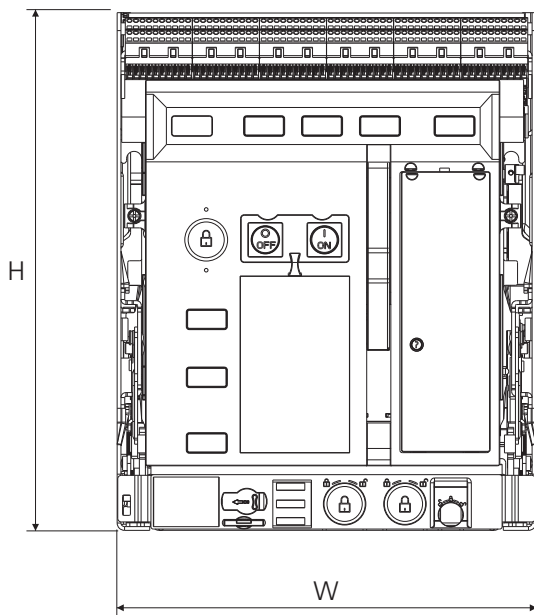

H : Height

W : Width

D : Depth with flat terminals

Rating Specification Parameters for 50% N ACB

		II	III
Frame		II	III
Version		S	H/V
Rated Uninterrupted Current at 50°C		In (A)	4000
Dimensions	Fixed ACB	581	747
	Draw out ACB	581	747

Rating Specification Parameters for 200% N ACB

		I	II	III
Frame		I	II	III
Version		N & S	S & H	H
Rated Uninterrupted Current at 50°C		In (A)	400-1250	1600 ⁽¹⁾ -2000
Dimensions	Fixed ACB	447	581	647
	Draw out ACB	447	581	647

(1) 1600A N also available

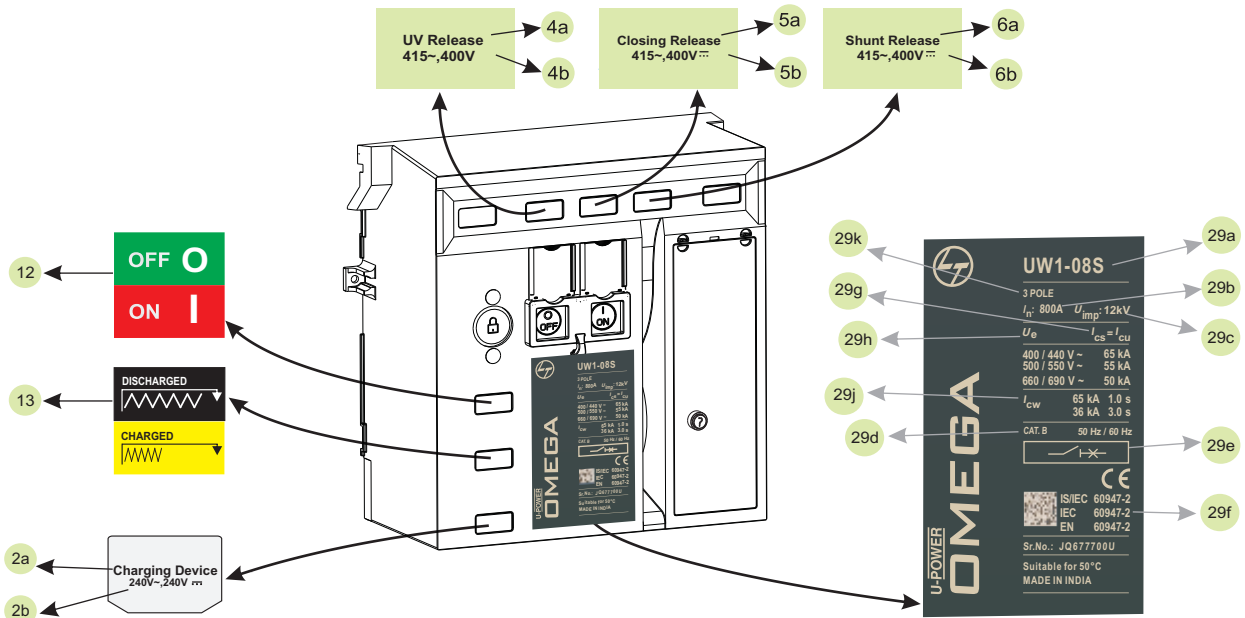

- 2a - Type designation for Electrical Charging device (ECD)
- 2b - Operating voltage for ECD
- 4a - Type designation for Under-voltage release (UVR)
- 4b - Operating voltage for UVR
- 5a - Type designation for Closing release (CR)
- 5b - Operating voltage for CR
- 6a - Type designation for Shunt release (SR/SRW)
- 6b - Operating voltage for SR/SRW
- 12 - ON-OFF indication
- 13 - Spring status indication

29a - **UW1-16S**

Rated Uninterrupted Current (I _n)		Version for Breaking Capacity	
04	400A	N	50 kA
06	630A	S	65 kA
08	800A	H	80 kA
10	1000A	V	100 kA
12	1250A	N08	50 kA, 800V AC
16	1600A	N10	50 kA, 1000V AC
20	2000A		
25	2500A		
32	3200A		
40	4000A		
50	5000A		
63	6300A		

- 29b - Rated Uninterrupted Current
- 29c - Rated impulse withstand voltage
- 29d - Utilization Category
- 29e - Suitability for isolation
- 29f - Standards compliance
- 29g - Rated Service breaking capacity
- 29h - Rated operational voltage
- 29j - Rated short-time withstand current
- 29k - No. of Pole & Pole details

Breaker:

- 1 Protection & Control Unit
- 2 Electrical Charging Device
- 3a Auxiliary Contacts
- 4 Under-voltage Release
- 4c Under-voltage Release Controller
- 5 Closing Release
- 6 Shunt Release
- 7 Ready-To-Close (Microswitch)
- 8b Secondary Isolating Contacts on Breaker
- 10 Operation Counter
- 12 ON-OFF Indication
- 13 Spring Status Indication
- 14 Charging Handle
- 21 Arc-Chute
- 24b Lifting Location on Breaker
- 33 Projection for resting Breaker on Cradle

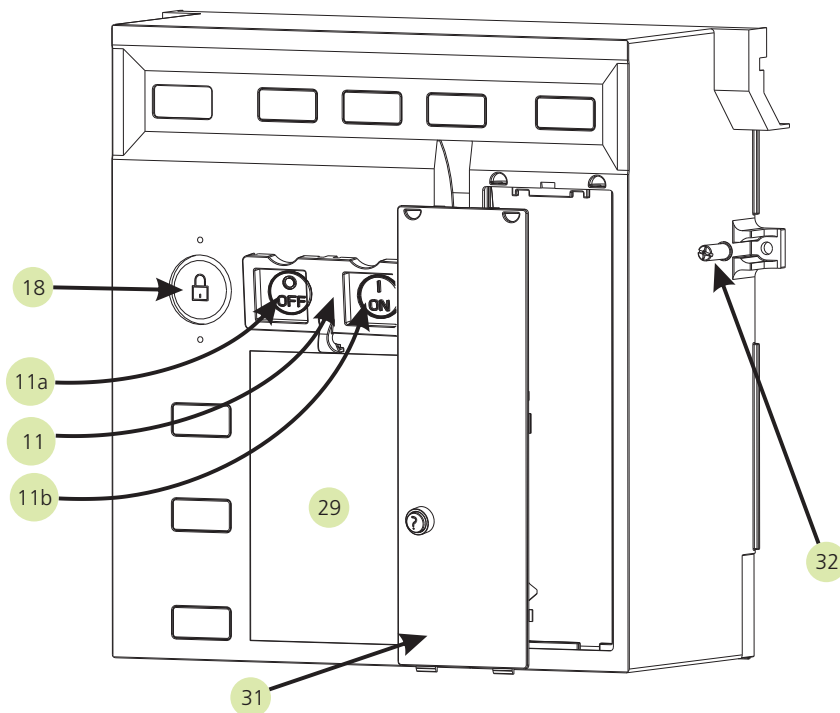
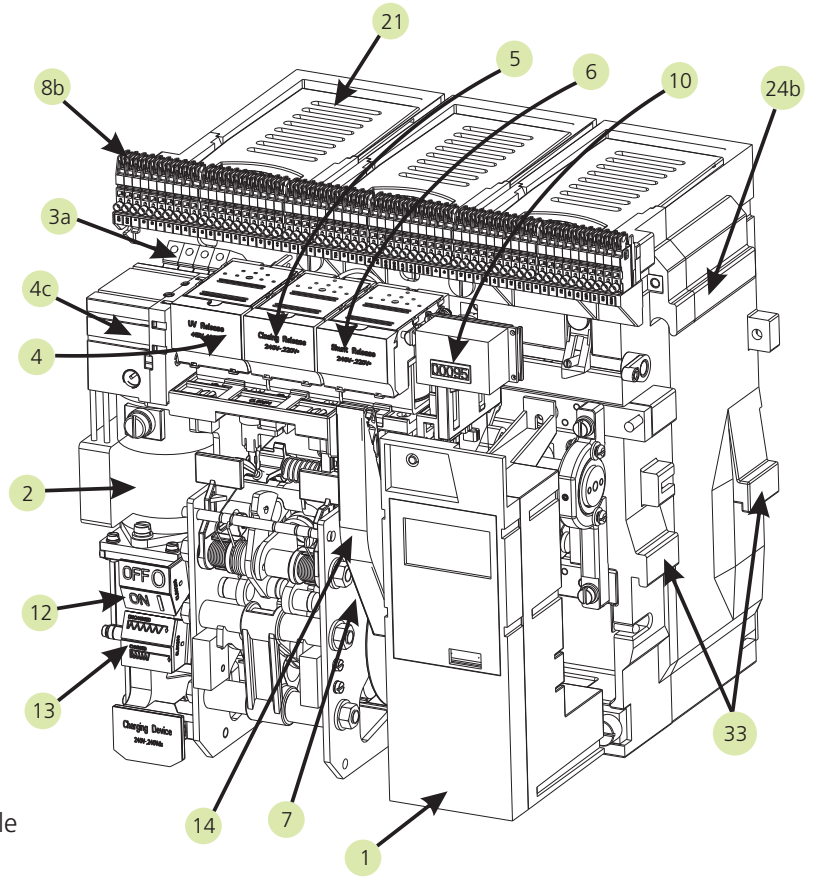

Facia:

- 11 Shroud for ON-OFF Buttons
- 11a OFF Button
- 11b ON Button
- 18 OFF Button locking
- 29 Laser Marked Breaker Specifications
- 31 Cover for Protection & Control Unit (UW-MTX Releases)
- 32 Facia Fixing screw

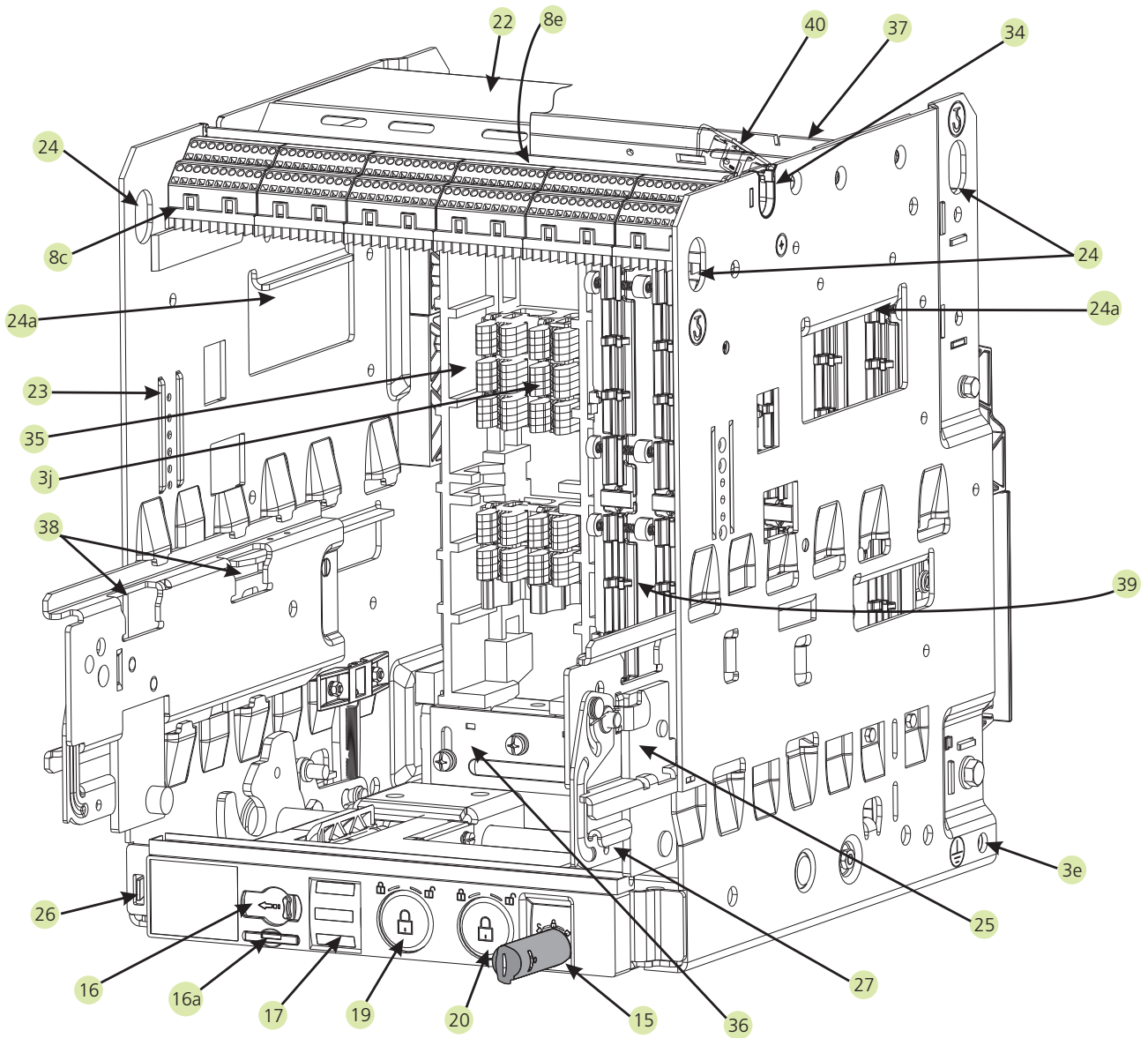

Cradle:

3e Hole for Earthing Connection
 3j Jaw Contacts
 8c Secondary Isolating Contacts on Cradle
 8e Electrical Position Indication
 15 Racking Handle
 16 Smart Racking-Shutter
 16a Pad-lock for Racking-Shutter
 17 Position Indicator

19 Position Lock – 1
 20 Position Lock – 2
 22 Arc-Shield
 23 Rating Error-Preventer
 24 Lifting Locations (4 nos.)
 24a Additional Lifting Locations
 25 Withdrawal Rails
 26 Door Racking Interlock
 27 Breaker Pull-out Handle

34 Guide for routing Control Wiring
 35 Terminal Supports
 36 Cradle Bottom cross-component
 37 Cradle Top cross-component
 38 Slot for placing breaker on Cradle
 39 Safety Shutter
 40 Door-Interlock

User friendly:

- Unique breaker front-facia architecture displays the electrical accessories mounted on the ACB (with rated control voltage & type of operating voltage)
- Modular & snap-fit accessories such as UVR, SR & CR modules, redefine the modularity on a time scale of 5 mins.
- Ease of on-site convertibility from Manual to Electrical & Fixed to Draw-out version
- Tool-less Arc-Chutes removal facilitates quick inspection of electrical contacts
- Indelibly marked Breaker Specifications on facia with Laser Marking
- RoHS compliant

Switchboard friendly:

- Three compact frame sizes help in optimizing the switchboard
- Right aligned design of ACB helps in better space utilization within the switchboard
- True 50% & 200% neutral options, along with the conventional 100% neutral (as standard) help in designing the switchboards as per applications & lead to optimized switchboard design
- Common height & depth across the range help in reducing the number of connection layouts & facilitate the easy modification of panel design & busbar layouts
- Terminal adaptors offer ease of configuration of vertical/horizontal busbar arrangements
- Option of interleaving busbar design at breaker terminals offer superior performance
- Supports multi-tier arrangement with minimal clearance with the help of arc-shield
- Self-aligning, Snap-fit Secondary Isolating Contacts enable the quick termination of 2 control wires (with Lugs) each of up to 2.5 sq.mm
- Option of customized neutral configuration (For 100%N only)
- 2m/3m/5m Bowden wire mechanical interlocking kit facilitates ease of mechanical interlocking among various frames of Fixed / Draw-out / Mixed versions of Omega ACBs
- Minimum 45mm* (Without Temperature Module) clearance above breaker facilitating Compact Multi-tier Switchboard design
- Best in class (40mm) Termination overlap with Busbars.

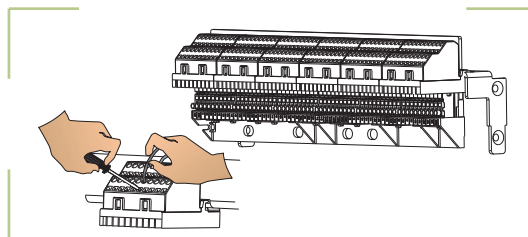
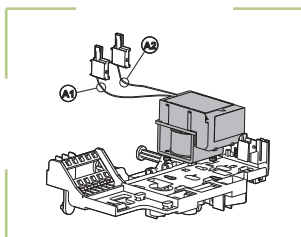
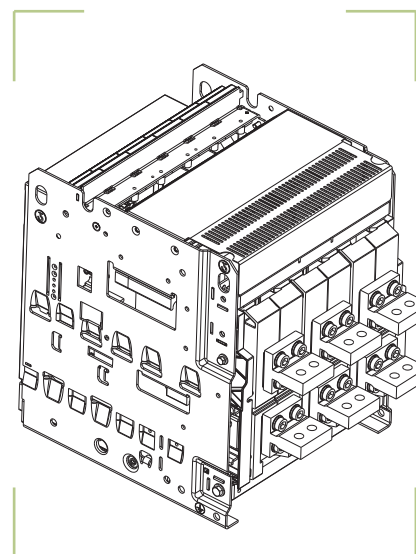
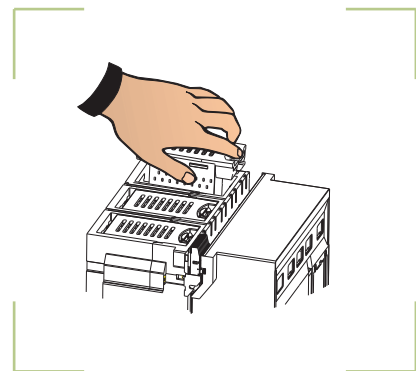
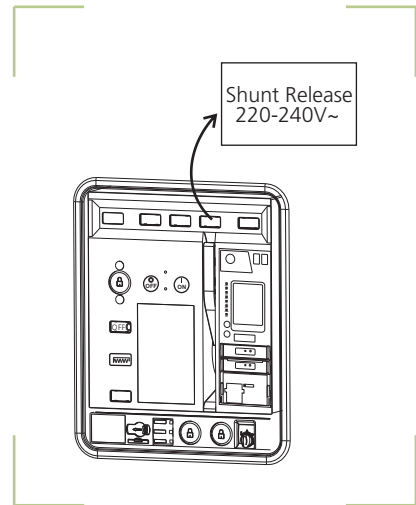

* Minimum 300mm in case of 800V/1000V AC ACBs

Superior Safety & Security:

- Inbuilt Electrical & Mechanical Anti-pumping prevents multiple breaker closures due to persistent closing commands
- Arc-Chute interlocking prevents the closure of ACB if arc-chute is missing or not properly installed
- Smart-racking shutter interlock ensures that breaker is switched-off before it is being racked-out
- Unique True Ready-To-Close (RTC) gives electrical signal after ensuring that:
 - a) Main spring is charged
 - b) Shunt release is de-energized
 - c) Under-voltage release is energized
 - d) Racking-Shutter is closed
 - e) Trip indication lever on electronic release is reset
 - f) Breaker is OFF
 - g) Arc-Chutes are properly placed

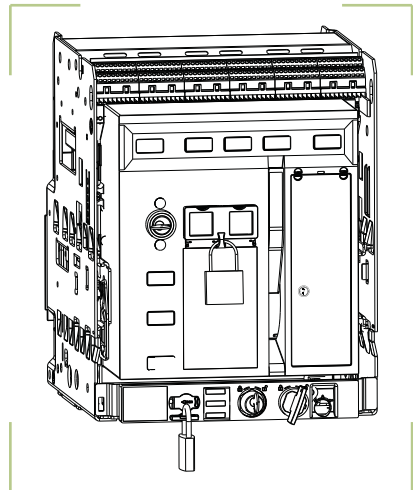
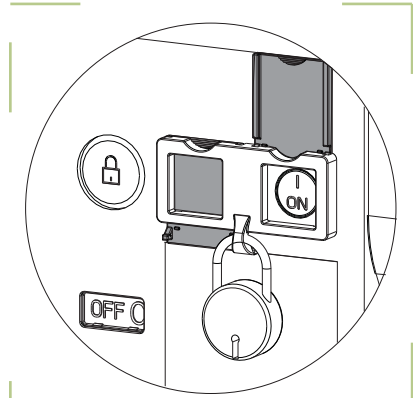

- ✦ Closing of ACB only in distinct Service/Test/Isolated positions ensures safety of the operating personnel
- ✦ Door-Racking interlock prevents rack-in/rack-out operation of breaker if panel door is open
- ✦ Modular safety-shutters to prevent unintended contact with terminals
- ✦ Rating Error-preventer avoids the breaker-cradle mismatch of rated current & breaking capacity version
- ✦ Option to pad-lock the ON/OFF push buttons independently to prevent unauthorized operations
- ✦ Facility to lock breaker in OFF condition offers the key-lock based interlocking arrangement
- ✦ Option for pad-locking the racking-shutter prevents the inadvertent racking operation & facilitates implementation of 'LOTO' system in industry
- ✦ Flexibility of locking the ACB in all positions or only in disconnected position
- ✦ Door-interlock prevents the opening of panel door in Service & Test positions
- ✦ Double insulation from Front Face (Class II operating safety)
- ✦ Shock & Vibration Protection as Per IEC-60947-1/IEC-60068-2-6/27
 - Vibration: 2 to 13.2Hz +/-1 mm
 - 13.2 to 100Hz 0.7g
 - Shock: 15g for 11 ms Half-sine wave

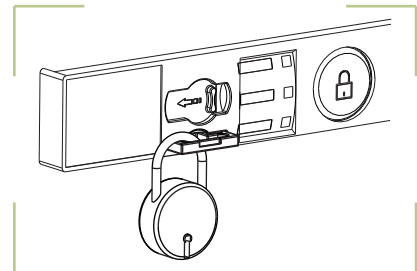
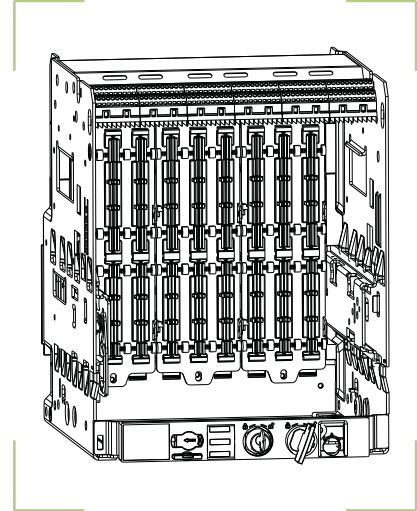

ANTI-PUMPING IN OMEGA AIR CIRCUIT BREAKER

Anti-pumping device is one which prevents the breaker from reclosing after an opening operation even though the device initiating closing is maintained in the position of closing.

Anti-pumping is generally achieved by providing electrical interlocks which ensure that the persistent closing command breaks the moment the breaker trips on fault or opens. The breaker can then be reclosed only after a fresh command is given. This method of providing anti-pumping is known as electrical anti-pumping.

Following anti-pumping methods are used to ensure reliability of entire distribution system.

- **Mechanical anti-pumping**

Mechanical anti pumping is achieved by providing linkage interlocks which ensure that anti-pumping lever does not reset until the manual persistent closing command is relieved. Even in case of a fault, breaker trips but the anti-pumping lever remains in the downward position until a persistent command is relieved. Hence the breaker can be reclosed only after a fresh command is given.

- **Electrical anti-pumping**

- a) **By providing external circuit**

To achieve this anti-pumping, there is a need for an auxiliary contactor or a relay which will get actuated by the first closing command and will break the closing circuit and will prevent the breaker from closing after the breaker has tripped on fault, this anti-pumping contactor or relay is reset only when the closing command is removed, thus providing anti-pumping.

- B) **By having inbuilt feature in closing release (CR) of OMEGA ACB**

In OMEGA, closing release consists of an electronic circuit to ensure no watt loss, inspite of continuous power supply, thus saving energy.

When a closing command is given, closing coil of the circuit breaker gets supply through an electronic circuit which comprises of IC555 timer. The closing coil is energized and the breaker closes. The closing command persists only for the 500ms time duration. In order to close the circuit breaker again, the closing coil circuit will have to be reset only when the closing command is removed. This ensures that once the breaker has closed and tripped on fault the breaker can close again only after the first closing command is removed and a fresh closing command is given, thus providing anti-pumping.

Matrix

Protection & Control Units





Matrix Release "A basket of benefits"

- 1) State-of-the-art touch-screen technology in Matrix 4.5 releases offer ease of navigation
- 2) Unique withdrawable power metering & communication modules offer ease of flexibility, scalability & customization of electrical systems
- 3) Option of both Modbus & Profibus industrial communication protocols
- 4) Zigbee offers wireless monitoring parameters of Matrix releases & supplementary modules
- 5) Wide range of Overload protection curves (such as I²t, I⁴t, SI & LI/VI) offer precise co-ordination with large variety of electrical loads
- 6) Option of Enabling/Disabling each protection function offers greater flexibility in designing the overall protection system
- 7) Directional & Double Short-circuit protection
- 8) Password protection in releases prevents unauthorized access to protection release
- 9) Unique O-LED display offers better contrast & wider-viewing angle
- 10) Ease of parameterisation through Configurator modules
- 11) Dual time-based set group protection provides the option of setting two sets of protection curves
- 12) Front connector for hand-held testing of release
- 13) Soft-rating plug offers precise protection of electrical system at lower value of system currents
- 14) Query button for last trip information furnishes the "Trip Info" details such as cause of tripping, date and time stamping of tripping
- 15) Test button for self-diagnostic test
- 16) 20 trip & 128 event records stored in the protection release*
- 17) Elimination of relays & measurement devices
 - Less time required for switchboard assembly (no wiring or cut-outs on the front panel)
 - Fewer devices required and less time spent on their selection, purchase, storage and installation
- 18) Harmonics metering up to 27th order of fundamental frequency along with display of THD
- 19) Oscillograph of fault current waveforms (10 cycles before pick-up/Trip & 5 cycles after pick-up/Trip)
- 20) Tested for Electromagnetic Compatibility (EMC) as per IEC-60947-2
- 21) Inbuilt & Optional Zone Selective Interlocking (ZSI)

* a : 20 trip and 10 events can be accessed on Release display.

b : 20 Trip and 128 events can be accessed through communication.

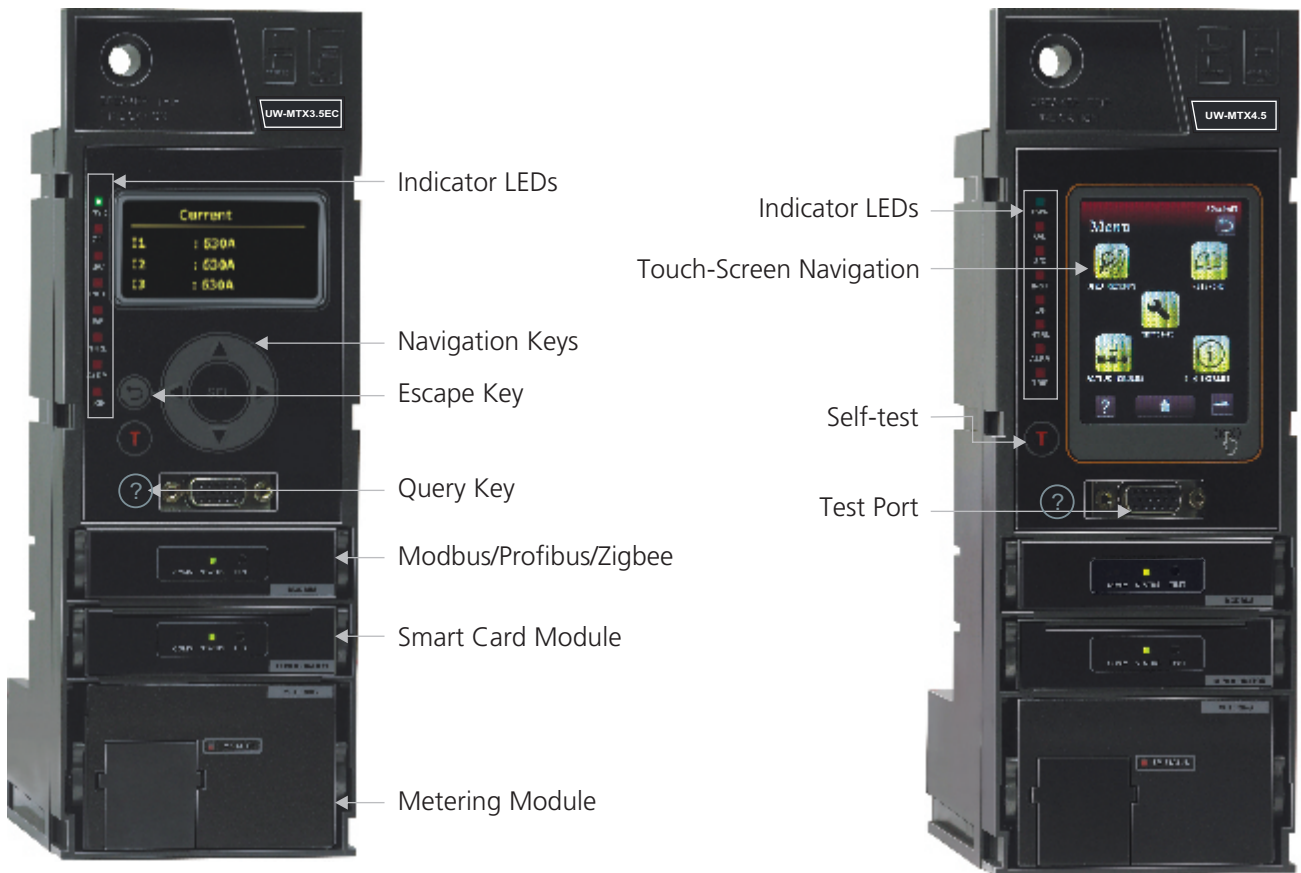

Matrix releases designed for "Flexibility, Scalability & Customization" offer wide variety of withdrawable modules such as Modbus, Profibus, Zigbee, Smart Configurator & Power metering. To start with one can go for a basic version of MTX3.5 release and based on future needs and system demands, one can upgrade the protection release with Power metering & Communication modules.

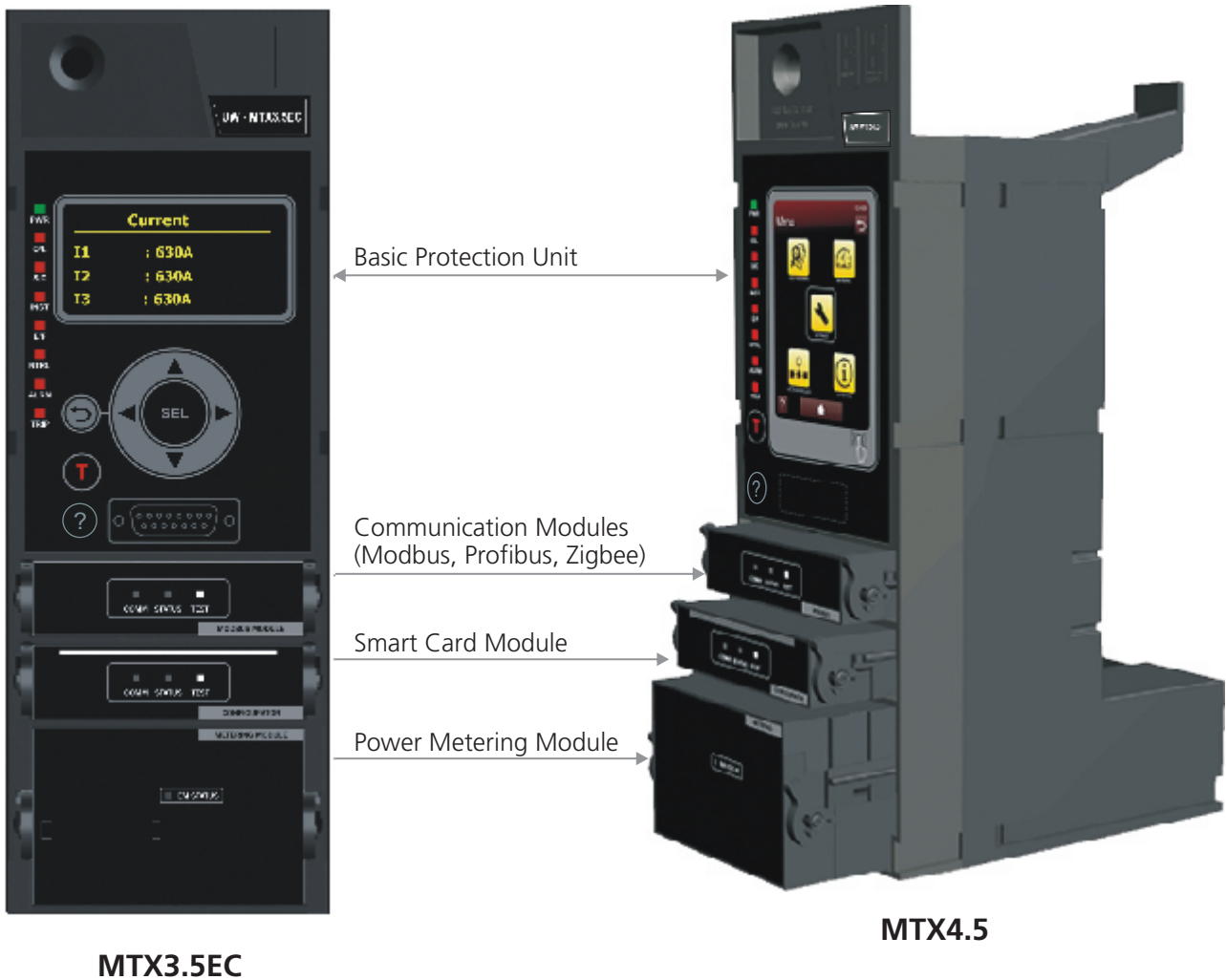



UW-MTX1.0



UW-MTX1G/1Gi



UW-MTX1.5G/1.5Gi

Features:

- Overload, Short-circuit & Instantaneous protection with adjustable current & time-delay settings
- Inbuilt Earth-Fault & neutral protection in MTX1G/1Gi & MTX1.5G/1.5Gi
- Switchable thermal memory for cable protection on repetitive overloads
- I²t ON curve for Short-circuit & Earth-fault protection
- Current Metering in MTX1.5G/1.5Gi through 3-line O-LED display
- Local fault annunciation through LED indication & pre-trip alarm
- Front accessible test port
- Query button for last trip record
- Inbuilt rating-plug through DIP switches
- Test button to check the health of protection release
- Self-powered protection
- Inbuilt Zone Selective Interlocking (ZSI) in MTX1Gi & MTX1.5Gi

Protection parameters:

Parameters		MTX1.0	MTX1G	MTX1Gi	MTX1.5G	MTX1.5Gi
Overload (Phase)	Protection: Enable/Disable	✓	✓	✓	✓	✓
	Pick-up (I _r)=I _n x...	OFF- 0.4-0.5-0.6-0.7-0.8-0.85-0.9-0.95-1				
	Delay (tr) in sec	10	0.5-1-2-4-6-12-18-24-30			
	Pre-alarm	0.9 x I _r (fixed)				
Overload (Neutral)	Thermal Memory ON/OFF	✓	✓	✓	✓	✓
	Protection: Enable/Disable	-	✓	✓	✓	✓
	Pick-up (I _n)=I _r x...	-	50%-100%-150%-200%			
	Pre-alarm	-	0.8 x I _n (fixed)			
Short-Circuit	Delay (tr) in s	-	Same as Overload Phase			
	Protection: Enable/Disable	-	-	-	-	-
	I ² t ON/OFF	✓	✓	✓	✓	✓
	Pick-up (I _s)=I _n x...	0.6-1-1.5-2-3-4-6-8-10-12				
Instantaneous	Delay (ts)	20-100-200-300-400 ms				
	Pre-alarm	0.5 x I _s (fixed)				
	Protection: Enable/Disable	✓	✓	✓	✓	✓
	Pick-up (I _p)=I _n x...	OFF-1.5-2-3-4-6-8-10-12-15				
Earth-Fault	Protection: Enable/Disable	-	✓	✓	✓	✓
	I ² t : ON/OFF	-	✓	✓	✓	✓
	Pick-up (I _g)=I _n x...	-	OFF-0.2-0.3-0.4-0.5-0.6			
	I ² t OFF (tg)	-	0.1-0.2-0.3-0.4-1			
	I ² t ON (tg)	-	0.1-0.2-0.3-0.4			
Inbuilt-ZSI	Pre-alarm	-	0.8 x I _g (fixed)			
	Short Circuit Enable/Disable	-	-	✓	-	✓
	Earth Fault Enable/Disable	-	-	✓	-	✓



UW-MTX3.5/3.5EC/3.5H



UW-MTX3.5H



UW-MTX4.5

Features	Parameter	MTX3.5	MTX3.5EC	MTX3.5H	MTX4.5
Basic Protection	Overload - Phase	✓	✓	✓	✓
	Overload - Neutral	✓	✓	✓	✓
	Short-Circuit	✓	✓	✓	✓
	Directional Short-Circuit	✓	✓	✓	✓
	Instantaneous	✓	✓	✓	✓
	Earth-Fault	✓	✓	✓	✓
Additional Protection	Current	✓	✓	✓	✓
	Voltage	*	✓	✓	✓
	Frequency	*	✓	✓	✓
	Reverse Power	*	✓	✓	✓
	Maximum Demand	*	✓	✓	✓
Trip Records	Last 20 trip data	✓	✓	✓	✓
Event Records	Last 10 Event Data	✓	✓	✓	✓
Smart Card		*	*	*	*
Communication	Modbus	*	✓	*	✓
	Profibus	*	*	*	*
	Zigbee (wireless)	*	*	*	*
Advanced Protection	Trip Circuit Supervision (TCS)	*	*	*	*
	Zone Selective Interlocking (ZSI)	*	*	*	*
	Temperature Rise (TM)	*	*	*	*
	Earth Leakage (EL)	*	*	*	*
	Restricted Earth-Fault (REF)	*	*	*	*
Additional Features	Relay Output	*	*	*	*
	Load Management (Pre Trip Alarm)	✓	✓	✓	✓
	Digital Input & Output	*	*	*	*
	Analog Output	*	*	*	*
Metering	Current	✓	✓	✓	✓
	% Loading	✓	✓	✓	✓
	Voltage	*	✓	✓	✓
	Power & Energy	*	✓	✓	✓
	Harmonics	-	-	✓	✓
Storable Settings (2 sets)		✓	✓	✓	✓
Auxiliary Supply (24V DC)		*	*	*	✓

* - Optional feature

✓ - Standard



UW-MTX3.5/3.5EC

- Overload, Short-circuit and Earth-fault protection with variable current & time delay setting
- Instantaneous protection
- I²t, I⁴t, SI, LIMI protection curves
- Directional & Double Short circuit protections
- Reverse power and phase sequence protection
- Selectable I²t based curves for short-circuit and earth-fault protection
- Switchable neutral overload protection (50%-200%) in step of 5%
- Additional current & voltage based protections
- Protection against temperature rise
- Advance protection - ZSI, TCS, REF & EL
- Communication through Modbus, Profibus & wireless Zigbee
- Smart Configurator module for easy parameterisation of the release
- Local & remote fault annunciation & pre-trip alarm
- Current, Voltage, Power, Energy & THD metering & % loading
- Earth Fault Protection from 10%In
- Dual time-based protection set groups
- Thermal reflectivity & soft rating-plug
- Self-powered protection
- Trip & Event recording



UW-MTX3.5H

- Overload, Short-circuit and Earth-fault protection with variable current & time delay setting
- Instantaneous protection
- I²t, I⁴t, SI, LIMI protection curves
- Current & Voltage harmonics metering
- Directional & Double Short circuit protections
- Reverse power and phase sequence protection
- Selectable I²t based curves for short-circuit and earth-fault protection
- Switchable neutral overload protection (50%-200%) in step of 5%
- Additional current & voltage based protections
- Protection against temperature rise
- Advance protection - ZSI, TCS, REF & EL
- Optional communication through Modbus, Profibus & wireless Zigbee
- Smart Configurator module for easy parameterisation of the release
- Local & remote fault annunciation & pre-trip alarm
- Current, Voltage, Power, Energy & THD metering & % loading
- Dual time-based protection set groups
- Thermal reflectivity & soft rating-plug
- Self-powered protection
- Trip & Event recording



UW-MTX4.5

- Overload, Short-circuit and Earth-fault protection with variable current & time delay setting
- I^2t , I^4t , SI, LIM protection curves
- Navigation through Touch-Screen
- Bar-graph representation of current, voltage & power parameters
- Directional & Double Short-circuit protection
- Instantaneous protection
- Selectable I^2t based curves for Short-circuit and Earth-fault protection
- Switchable neutral overload protection (50%-200%) in step of 5%
- Harmonics metering up to 27th order of fundamental frequency along with display of THD percentage
- Oscillograph of fault current waveforms (10 cycles before pick-up/Trip & 5 cycles after pick-up/Trip)
- Metering of sequence components of current waveform, form factor, peak factor
- Additional current & voltage based protections
- Protection against temperature rise
- Advance protection - ZSI, TCS, REF & EL
- Communication through Modbus, Profibus & wireless Zigbee
- Local & remote fault annunciation & pre-trip alarm
- Dual time-based protection set groups
- Thermal reflectivity & soft rating-plug
- Self-powered protection
- Trip & Event recording

Simulation Kit for Matrix releases

- Universal test kit for all versions of Matrix releases
- Generates 3 phase current and voltage with adjustable phase angles
- Graphical display & smart GUI with multi-functional key operation
- Portable & hand held device to simulate faults
- Dual Power ON-battery & external supply
- Auto sensing of release connectivity
- Stores 10 test records



Basic protection in UW-MTX 3.5/3.5EC/3.5H/4.5 Series

	Parameter	UW-MTX3.5	UW-MTX3.5EC	UW-MTX3.5H	UW-MTX3.5H/4.5
Overload (Phase)	Protection : Enable/Disable	✓	✓	✓	✓
	Pick-Up (I_r)= I_n x ...for I^2t , I^4t , SI, L/VI	0.4 to 1 I_n in step of 0.05			
	Delay(tr) in s	0.5-1-2-4-6-12-18-24-30			
	Pre-alarm	0.5 to 0.95 in step of 0.05 x I_r			
	Thermal Memory ON/OFF	✓	✓	✓	✓
Overload (Neutral)	Protection: Enable/Disable	✓	✓	✓	✓
	Pick-Up $I_n=I_r$ x ...	0.5 to 2 in step of 0.05			
	Pre-alarm	0.5 to 0.95 in step of 0.05 x I_n			
	Delay(tr) in s	same as Overload Phase			
Short-Circuit	Protection: Enable/Disable	✓	✓	✓	✓
	Double S/C ON/OFF	✓	✓	✓	✓
	I^2t ON/OFF	✓	✓	✓	✓
	Pick-Up I_{Lo} , $I_s=I_n$ x ...	0.6 to 12 I_n in step of 0.05			
	Pick-Up I_{Hi} , $I_s=I_n$ x ...	0.6 to 12 I_n in step of 0.05			
	Delay I_{Hi} (ts)	20-100-200-300-400 ms			
	Delay I_{Lo} (ts)	20-100-200-300-400 ms			
	Pre-alarm	0.5 to 0.95 in step of 0.05 x I_s			
	Cold Pick-Up ON/OFF	✓	✓	✓	✓
	Cold Delay	100 ms to 10s in step of 100ms			
Directional Short-Circuit	Protection: Enable/Disable	✓	✓	✓	✓
	Direction: Top/Bottom	✓	✓	✓	✓
	I^2t : ON/OFF	✓	✓	✓	✓
	Pick-up(I_s): I_n x ...	0.6 to 12 I_n in step of 0.05			
	Delay(ts)	20-100-200-300-400 ms			
	Pre-alarm	0.5 to 0.95 in step of 0.05 x I_s			
	Cold Pick-Up ON/OFF	✓	✓	✓	✓
	Cold Delay	100 ms 10s in step of 0.05 x I_s			
Instantaneous	Protection: Enable/Disable	✓	✓	✓	✓
	Pick-up(I_p)= I_n x ...	1.5 to 10 in step of 0.1; 10 to 15 in step of 1			
Earth-Fault	Protection: Enable/Disable	✓	✓	✓	✓
	I^2t : ON/OFF	✓	✓	✓	✓
	Pick-Up(I_g)= I_n x ...	0.1-0.2-0.3-0.4-0.5-0.6			
	I^2t OFF(tg)	100 ms to 1s in step of 100 ms			
	I^2t ON(tg)	100-200-300-400 ms			
	Pre-alarm	0.5 to 0.95 in step of 0.05 x I_g			
	Cold Pick-Up: ON/OFF	✓	✓	✓	✓
	Cold Delay	100ms to 5sec in step of 100 ms			

Advanced protection in UW-MTX 3.5/3.5EC/3.5H/4.5 Series

	Parameter	UW-MTX3.5*	UW-MTX3.5EC	UW-MTX3.5H	UW-MTX 4.5
Under Current	Protection: Enable/Disable	✓	✓	✓	✓
	Pick-Up= $I_r \times \dots$	0.2 to 0.8 in step of 0.05			
	Delay	1 to 255sec in step of 1sec			
	Mode: Trip/Alarm/Both	✓	✓	✓	✓
Current Unbalance	Protection: Enable/Disable	✓	✓	✓	✓
	Pick-Up= $I_n \times \dots$	10 to 90% in step of 5%			
	Delay	500 ms to 60s in step of 0.5s			
	Mode: Trip/Alarm/Both	✓	✓	✓	✓
Under Voltage	Protection: Enable/Disable	✓	✓	✓	✓
	Pick-Up(V_s)= $V_n \times \dots$	0.7 to 0.95 in steps of 0.01			
	Delay	100 ms to 5s in step of 100 ms			
	V_s reset	1.01/1.02/1.03/1.04 x V_s			
	Mode: Trip/Alarm/Both	✓	✓	✓	✓
Over Voltage	Protection: Enable/Disable	✓	✓	✓	✓
	Pick-Up(V_s)= $V_n \times \dots$	1.05 to 1.5 V_n in step of 0.01			
	Delay	100 ms to 5s in steps of 100 ms			
	V_s reset	0.95 to 0.99 V_s in step of 0.01			
	Mode: Trip/Alarm/Both	✓	✓	✓	✓
Voltage Unbalance	Protection: Enable/Disable	✓	✓	✓	✓
	Pick-Up(V_s)= $V_n \times \dots$	5 to 20% in step of 1%			
	Delay	500ms to 60s in step of 0.5s			
	V_s reset	0.95 to 0.99 V_s in step of 0.01			
	Mode: Trip/Alarm/Both	✓	✓	✓	✓
Residual Voltage	Protection: Enable/Disable	✓	✓	✓	✓
	Pick-Up (V_s)= $V_n \times \dots$	0.15/0.2/0.25/0.3/0.4			
	Delay	100ms to 5s in step of 100 ms			
	V_s Reset	0.95 to 0.99 V_s in step of 0.01			
	Mode: Trip/Alarm/Both	✓	✓	✓	✓
Under Frequency	Protection: Enable/Disable	✓	✓	✓	✓
	Pick-Up (F_n)	45-50 Hz in step of 0.1Hz			
	Delay	1-30sec in step of 0.1sec			
	Reset Freq	1.01 to 1.05 F_n in step of 0.01			
	Mode: Trip/Alarm/Both	✓	✓	✓	✓
Over Frequency	Protection: Enable/Disable	✓	✓	✓	✓
	Pick-Up (F_n)	50-55 Hz in step of 0.1 Hz			
	Delay	1-30sec in step of 0.1sec			
	Reset Freq	0.95 to 0.99 F_n in step of 0.01			
	Mode: Trip/Alarm/Both	✓	✓	✓	✓
Rev Power	Protection: Enable/Disable	✓	✓	✓	✓
	Pick-Up= $P_n \times \dots$	0.05 to 0.4 in step of 0.01			
	Delay	100ms-20s in step of 0.1s			
	Mode: Trip/Alarm/Both	✓	✓	✓	✓
Earth Leakage**	Mode: Trip/Alarm/Both	✓	✓	✓	✓
	Protection: Enable/Disable	✓	✓	✓	✓
	Pick-Up(I_r)	0.3 to 30A in step of 0.1 A			
	Delay	100-200-300-400-500 ms			
Restricted EF**	Protection: Enable/Disable	✓	✓	✓	✓
	I^2t : OFF/ON	✓	✓	✓	✓
	Pick-Up(I_g)= $I_n \times \dots$	0.1 to 0.6 in step of 0.1			
	I^2t OFF (tg)	100 ms to 5sec in step of 0.1s			
	I^2t ON (tg)	100-200-300-400 ms			
	Pre-alarm	0.5 to 0.95 in step of 0.05 x I_g			
	Cold Pick-Up: ON/OFF	60 ms to 10s in step of 20ms			
	Mode: Trip/Alarm/Both	✓	✓	✓	✓

✓ Available

* Requires Power Metering module for Advanced Voltage based Protection

** Requires additional modules

Advanced Protection in UW-MTX 3.5/3.5EC/3.5H/4.5 Series

	Parameter	UW-MTX3.5*	UW-MTX3.5EC	UW-MTX3.5H	UW-MTX4.5
Leading PF	Protection: Enable/Disable	✓	✓	✓	✓
	Pick-Up=Pf x ...	0.5 to 0.99 in step of 0.01			
	Delay	1/2/3/4/5 s			
	Mode: Trip/Alarm/Both	✓	✓	✓	✓
Lagging PF	Protection: Enable/Disable	✓	✓	✓	✓
	Pick-Up=Pf x ...	0.5 to 0.99 in step of 0.01			
	Delay	1/2/3/4/5 s			
	Mode: Trip/Alarm/Both	✓	✓	✓	✓
MD Active	Protection: Enable/Disable	✓	✓	✓	✓
	Type	Deliver/Receive			
	Pick-Up=En x ...	0.4 to 1 in step of 0.01			
	Mode: Trip/Alarm/Both	✓	✓	✓	✓
MD Reactive	Protection: Enable/Disable	✓	✓	✓	✓
	Type	Deliver/Receive			
	Pick-Up=En x ...	0.4 to 1 in step of 0.01			
	Mode: Trip/Alarm/Both	✓	✓	✓	✓
MD Apparent	Protection: Enable/Disable	✓	✓	✓	✓
	Type	Deliver/Receive			
	Pick-Up=En x ...	0.4 to 1 in step of 0.01			
	Mode: Trip/Alarm/Both	✓	✓	✓	✓
Phase Sequence	Protection: Enable/Disable	✓	✓	✓	✓
	Delay	100ms to 5s in step of 100ms			
	Mode: Trip/Alarm/Both	✓	✓	✓	✓
Breaker Failure	Protection: Enable/Disable	✓	✓	✓	✓
	Delay	50ms to 2sec in step of 0.05sec			

✓ Available * Requires Power Metering module for Advanced protections

Metering Functions

Parameter	Screen abbreviation	Details	MTX 3.5	MTX 3.5EC	MTX3.5H	MTX4.5
Current	I	Phase, Neutral and Earth	✓	✓	✓	✓
	I _Δ , IREF [§]	Earth Leakage, Restricted EF Current	✓	✓	✓	✓
	I max	Maximum Running Current Per Phase	✓	✓	✓	✓
	% Load	Percentage Loading Per Phase	✓	✓	✓	✓
	Avg.I	Average Phase Current	✓	✓	✓	✓
Voltage	V	Phase-Neutral Voltage	*	✓	✓	✓
	Max V	Maximum Voltage Per Phase	*	✓	✓	✓
	V12	Ph-Ph Voltage	*	✓	✓	✓
	Max V12	Maximum Ph-Ph Voltage	*	✓	✓	✓
	Avg. Vp-p	Average Ph-Ph Voltage	*	✓	✓	✓
	Avg Vp-n	Average Ph-N Voltage	*	✓	✓	✓
Frequency	F	System Frequency	*	✓	✓	✓
Power Factor	PF	System Power Factor	*	✓	✓	✓
Power	W	Active Power Per Phase and Total (kW)	*	✓	✓	✓
	VAr	Reactive Power Per Phase and Total (kVar)	*	✓	✓	✓
	VA	Apparent Power Per Phase and Total (kVA)	*	✓	✓	✓
Energy	Wh	Active Energy Per Phase and Total (kwh)	*	✓	✓	✓
	VArh	Reactive Energy Per Phase and Total (kVArh)	*	✓	✓	✓
	VAh	Apparent Energy Per Phase and Total (kVAh)	*	✓	✓	✓
Max Demand	Wh	Active Energy	*	✓	✓	✓
	VArh	Reactive Energy	*	✓	✓	✓
	VAh	Apparent Energy	*	✓	✓	✓
Temperature [#]	∅	Temperature Per Phase & Neutral (°C)	✓	✓	✓	✓
Harmonics Metering	THD, Current & Voltage components	Phase-1, 2 & 3-Total, Fundamental, THD	-	-	✓	✓

* Requires Power Metering module # Requires Temperature module
 ✓ Available
 § requires additional REF module

Overload - I^2t

(UW-MTX 1.0/1G/1Gi/1.5G/1.5Gi/3.5/3.5EC/3.5H/4.5)

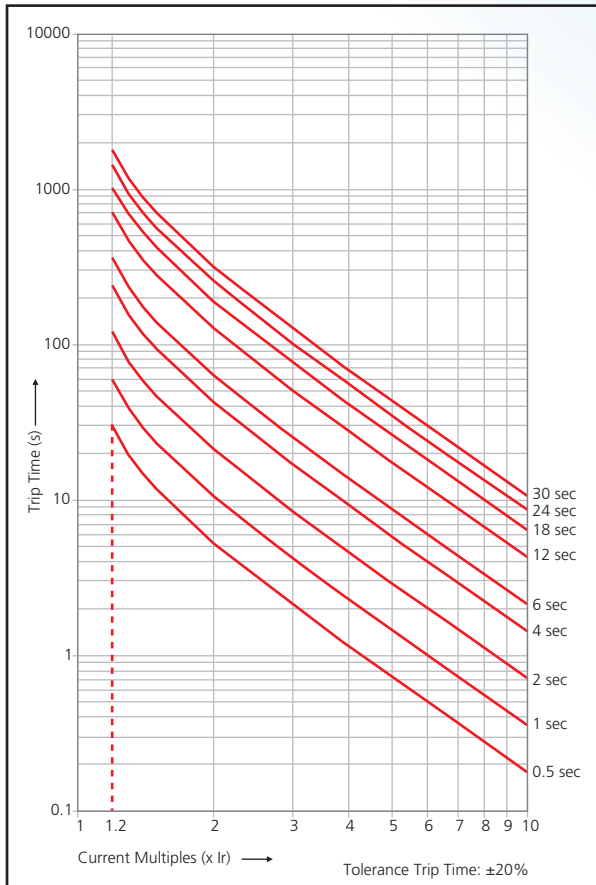

Instantaneous

(UW-MTX 1.0/1G/1Gi/1.5G/1.5Gi/3.5/3.5EC/3.5H/4.5)

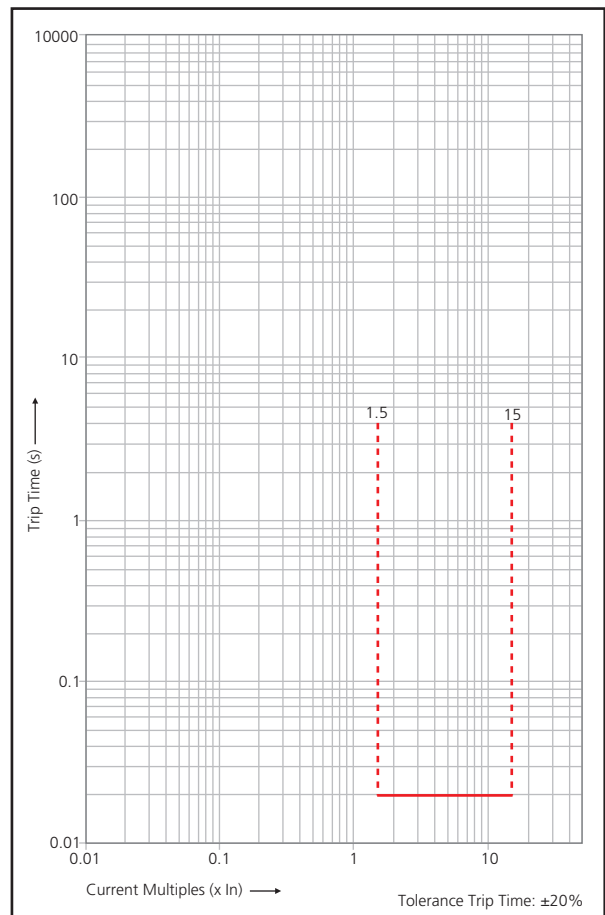

Short-Circuit - I^2t ON

(UW-MTX 1.0/1G/1Gi/1.5G/1.5Gi/3.5/3.5EC/3.5H/4.5)

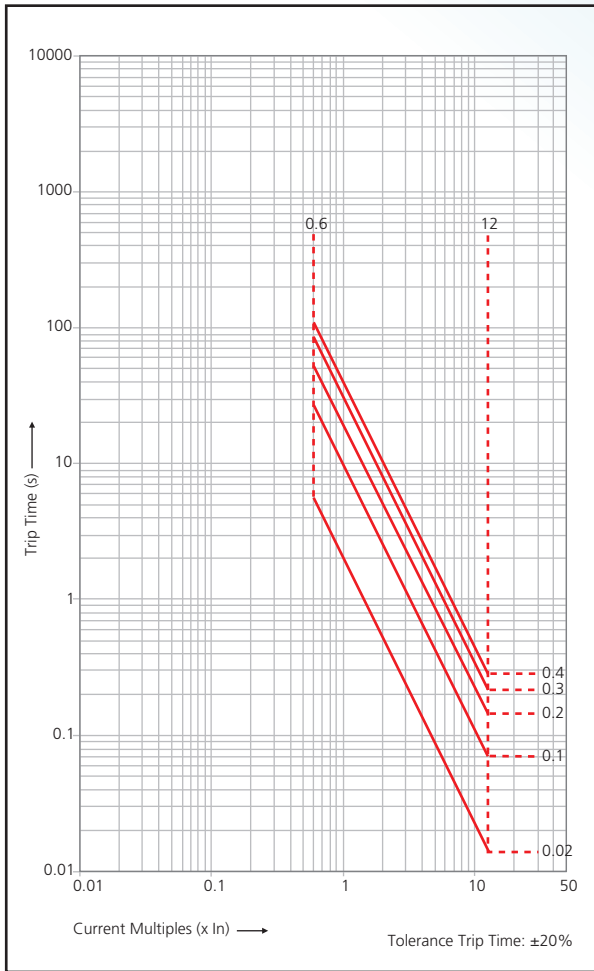

Short-Circuit - I^2t OFF

(UW-MTX 1.0/1G/1Gi/1.5G/1.5Gi/3.5/3.5EC/3.5H/4.5)

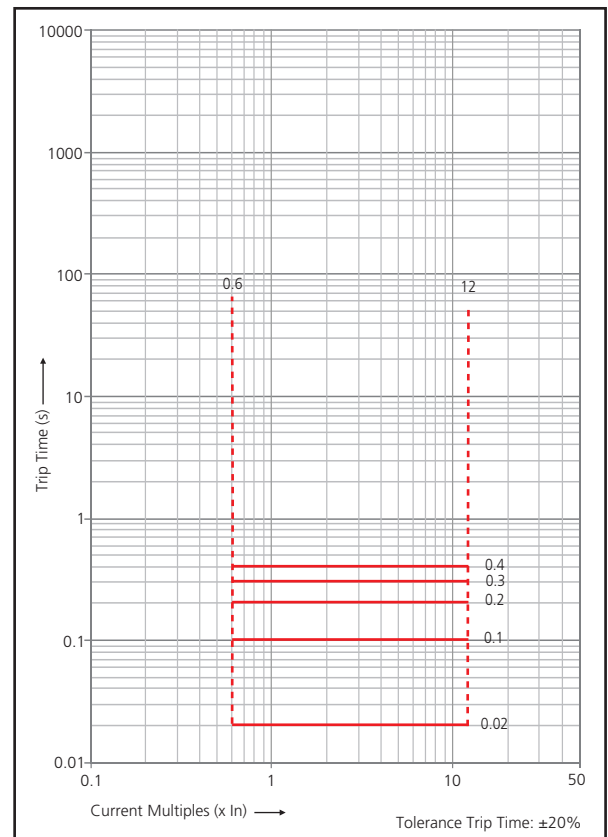

Ground Fault - I²t ON

(UW-MTX 1.0/1G/1Gi/1.5G/1.5Gi/3.5/3.5EC/3.5H/4.5)

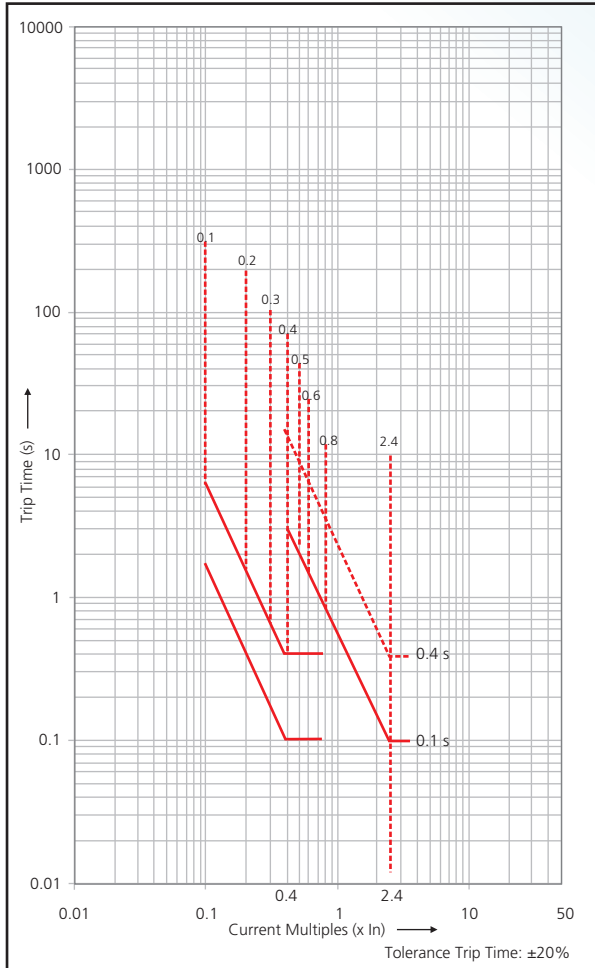

Ground Fault - I²t OFF

(UW-MTX 1.0/1G/1Gi/1.5G/1.5Gi/3.5/3.5EC/3.5H/4.5)

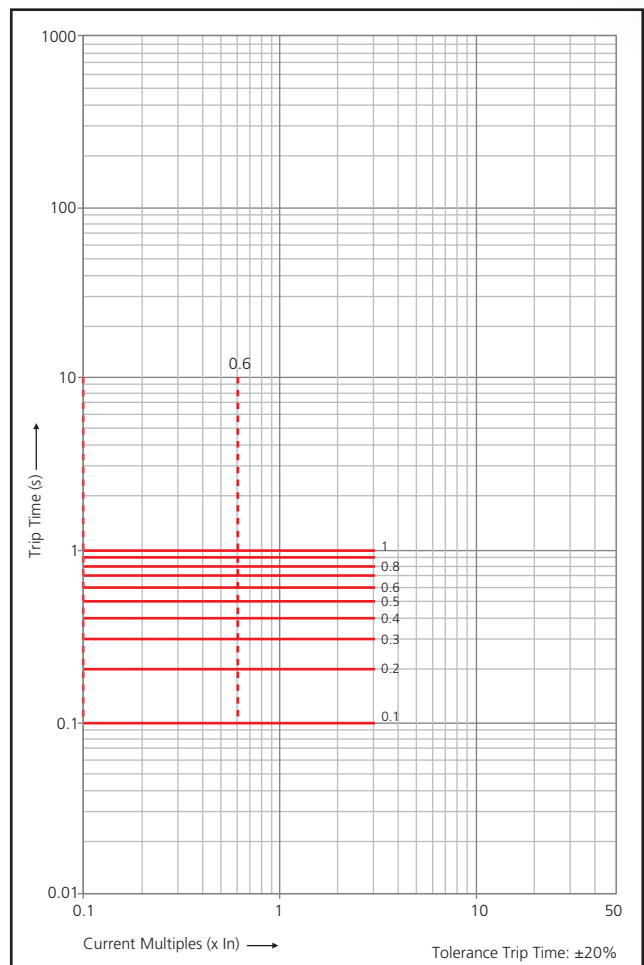

Overload - I^2t (UW-MTX1.0)

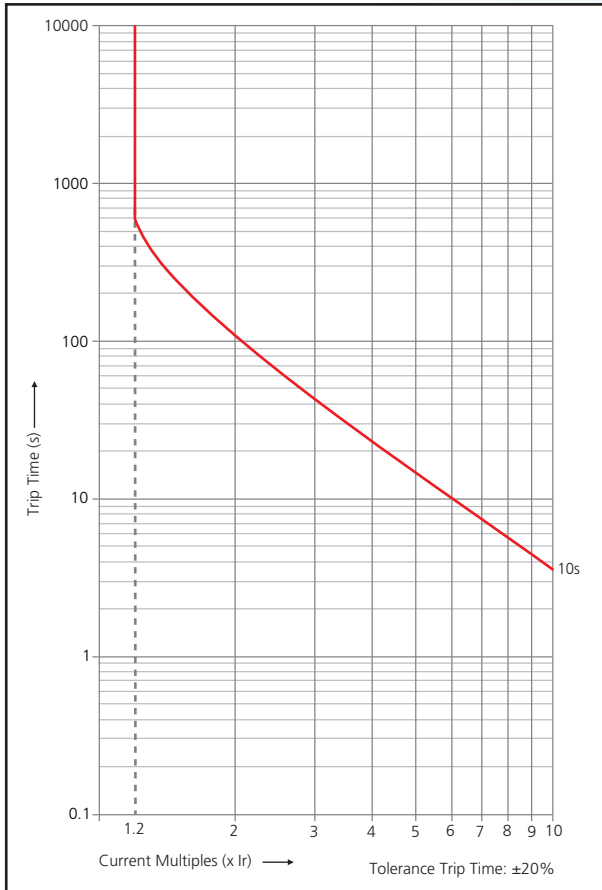

Overload - I^4t (UW-MTX3.5/3.5EC/3.5H/4.5)

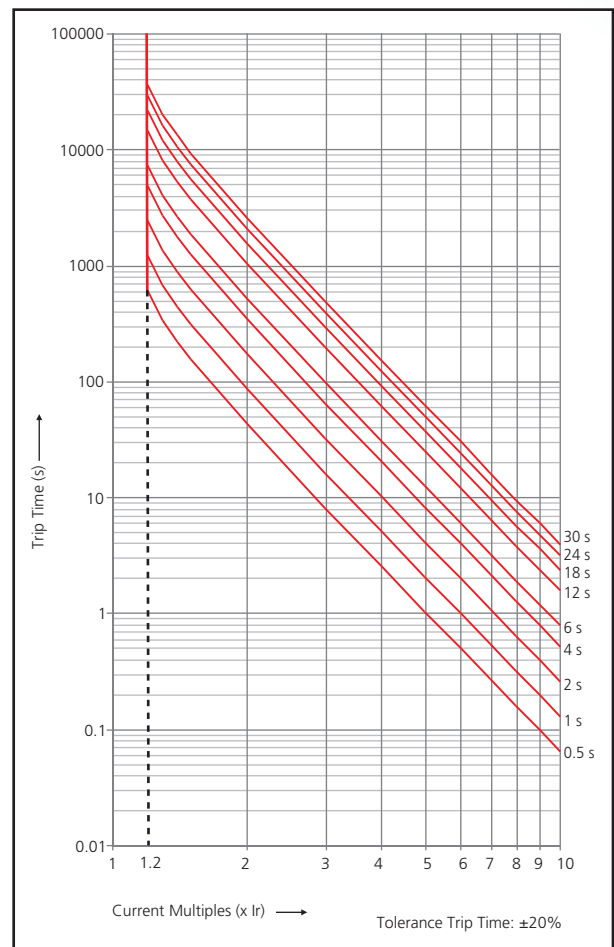

Overload - SI

(UW-MTX3.5/3.5EC/3.5H/4.5)

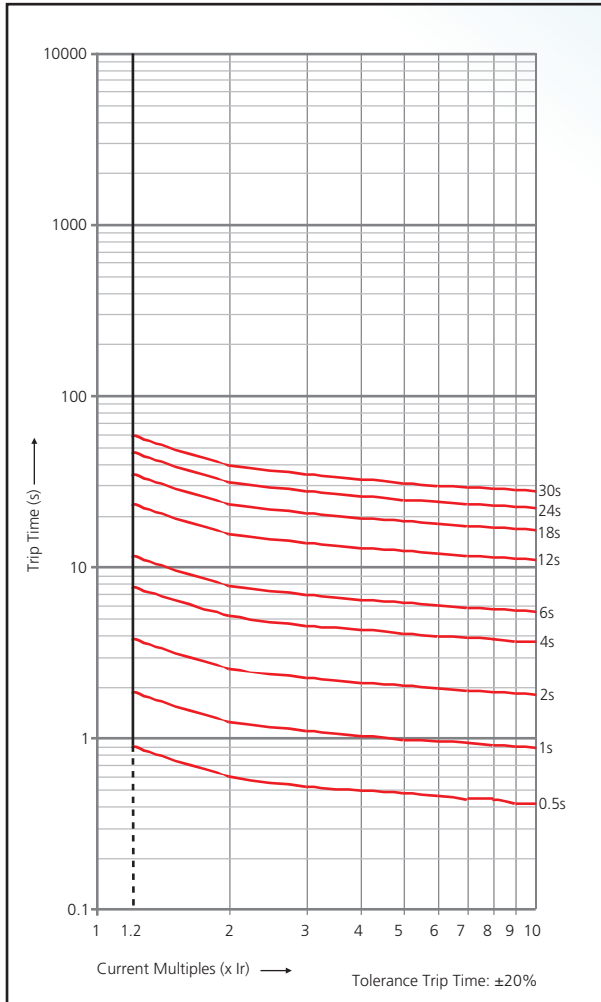

Overload - LI/VI

(UW-MTX3.5/3.5EC/3.5H/4.5)

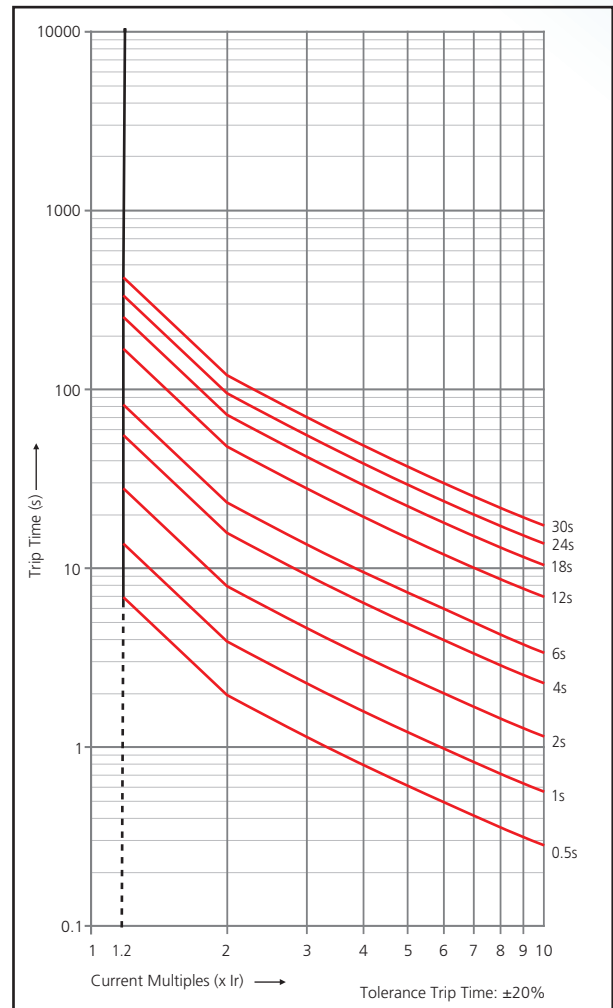

Over voltage causes and effects

Over voltage (or surges) in the power system are the abrupt rise in the voltage level in the system. There could be several reasons for over voltage. The normal operating voltages of the system do not stress the insulation severely. But the voltage stresses due to over voltages can be so high that they may become dangerous to both the cables and the connected equipment and may cause damage, unless some protective measure against the over-voltages are taken. Over-voltages occurrence in the system can be categorized by reasons:

1. EXTERNAL OVER VOLTAGES:

These over-voltages originate from the atmospheric disturbances, mainly due to lightning. These over-voltages take the form of a unidirectional impulse whose maximum possible amplitude has no direct relation with the operating voltage of the system. They may be due to any one of the following causes:

- a. Direct lightning strokes

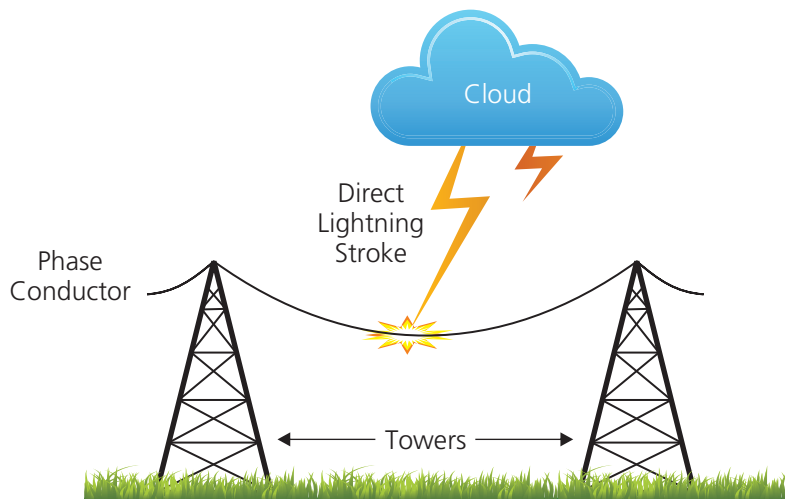

- b. Electromagnetically induced voltages due to the lightning discharge near the line (sidestroke)
- c. Voltage induced due to the changing atmospheric condition along the transmission line
- d. Electrostatically induced over voltages due to the presence of the charged clouds
- e. Due to the friction of the charged particles like dust, snow in the atmosphere or due to change in the altitude of the line

2. INTERNAL OVER VOLTAGES:

Caused due to changes in the operating condition of the network. Can be further classified in two groups:

a. Switching or transient over voltages

These over voltages are generally of oscillatory nature caused by the transient phenomena which appears when the state of the network is changed by switching operation or a fault condition.

The frequency of the oscillations is governed by the inherent inductance and capacitance of the system & may vary from few hundred Hz to few kHz

- For e.g.
- i. Switching On & OFF of equipment, like switching of high voltage reactors or switching of transformer on no load
 - ii. If fault occurs in any one phase the voltage of other phases with respect to the ground increases until the faults get cleared
 - iii. Because of the re-striking voltage across the contacts of the breaker, when breaker has tripped on fault, voltage of amplitude nearly twice the system voltage and relatively high frequency gets generated

b. Steady-state or temporary over voltages

These are over voltages developed due to the disconnection of loads at power frequency.

DIRECTIONAL SHORT CIRCUIT PROTECTION

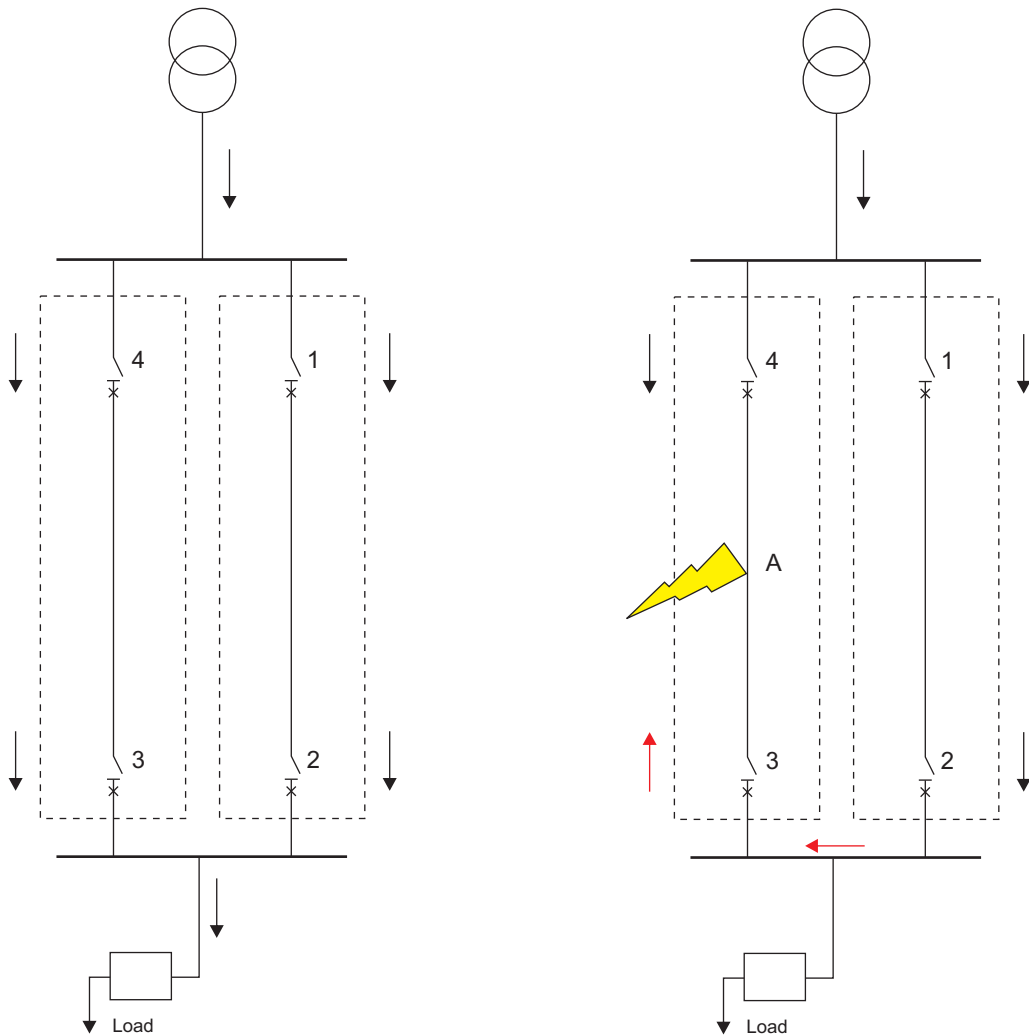

Consider a single-end-fed system of parallel feeders. in the normal condition Circuit Breakers 1, 2, 3 and 4 will be closed and will feed the load through two parallel feeders (Fig1). when the fault occurs at point A Breaker 4 will see the fault in its zone and trip as per its time delay settings. Breaker 3 will remain closed as fault is not in its zone. To keep the load bus charged Breaker 1 and 2 should be closed and feed the load.

The direction of current flow at Breaker 3 will get reversed and allow to feed fault at point A as shown in fig 2. reverse short circuit protection. To prevent such situation Breaker 3 should sense this reversal of power flow and should trip immediatily to provide complete isolation of the fault at A. while the supply to the load remain intact through the Breaker 1 and Breaker2. this funtion of Breaker 3 is called reverse short circuit protection.

Linear Loads:

The AC loads are called linear loads when the current and voltage resultant waveform is sinusoidal in nature (i.e. not distorted). Also the current at any instant is proportional to the voltage at that instant.

Thus in linear systems there are no harmonic components in current and the voltage waveforms.

e.g. Heaters, Power factor improvement capacitors, etc.

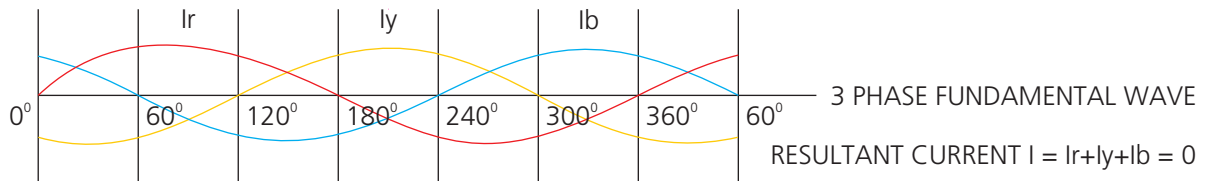

CURRENT WAVE FOR LINEAR LOAD

Non-Linear Loads:

The AC loads which cause the current waveform to distort from the normal sinusoidal nature are called as non-linear loads. Current distortion leads to the distortion of the voltage waveform also. Thus the voltage and current are no longer proportional.

The distorted current and the voltage waveforms can be decomposed into pure sinusoidal and associated frequencies of the higher order through Fourier Transformation.

Harmonic spectrum gives a clear analysis of amount and order of the harmonics present in the system, which helps in the designing the filter for the system.

e.g. SMPS, Rectifiers, PLC, Electronic Ballasts, Laser Printers, Computers, etc.

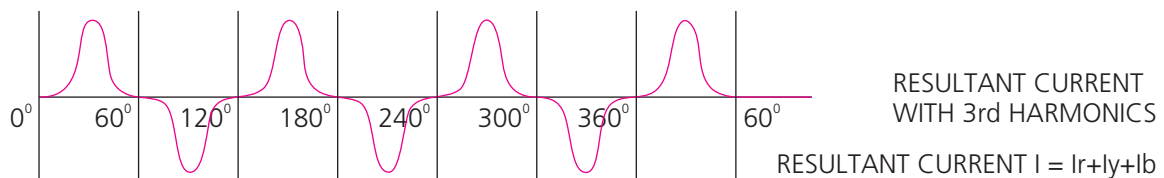

CURRENT WAVEFORM FOR NON-LINEAR LOAD

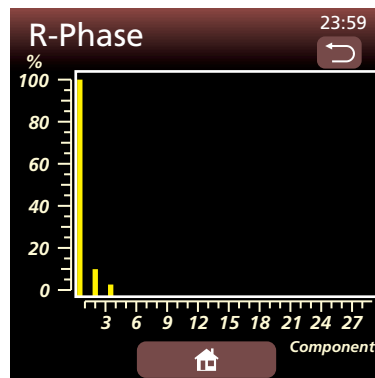

HARMONIC SPECTRUM

Harmonics are basically the sinusoidal component of the periodic wave with frequency that is an integral multiple of the fundamental frequency.

Harmonics content purely determines the quality of power. Having harmonics in the system will affect the system and the severity of effect on the system/equipment will depend on the stiffness of the system and the amount of the harmonic pollution.

Harmonics can be generated in the system because of the following reasons:

- Non-linear loads generate current harmonics
- Harmonic currents flow largely through capacitors
- Harmonic currents also flow through network
- The flow of harmonic currents causes voltage harmonics
- Harmonics are thus injected to other linear loads connected in the same bus
- Harmonics injected into the network flow towards other users connected to the network

Some of the typical loads causing the generation of the harmonics in the system are:

- ***Equipment using switched mode power supply:***
 - ▶ Television
 - ▶ Computers, other IT loads
- ***Equipment using power electronic devices:***
 - ▶ AC & DC drives
 - ▶ Frequency converters
 - ▶ Rectifiers
 - ▶ Arc & induction furnaces
 - ▶ UPS

Some of the typical results of the harmonics in the system are:

1. Neutral over current: Odd triplen harmonics because of its additive nature adds up in the neutral current causing the overheating of the neutral.

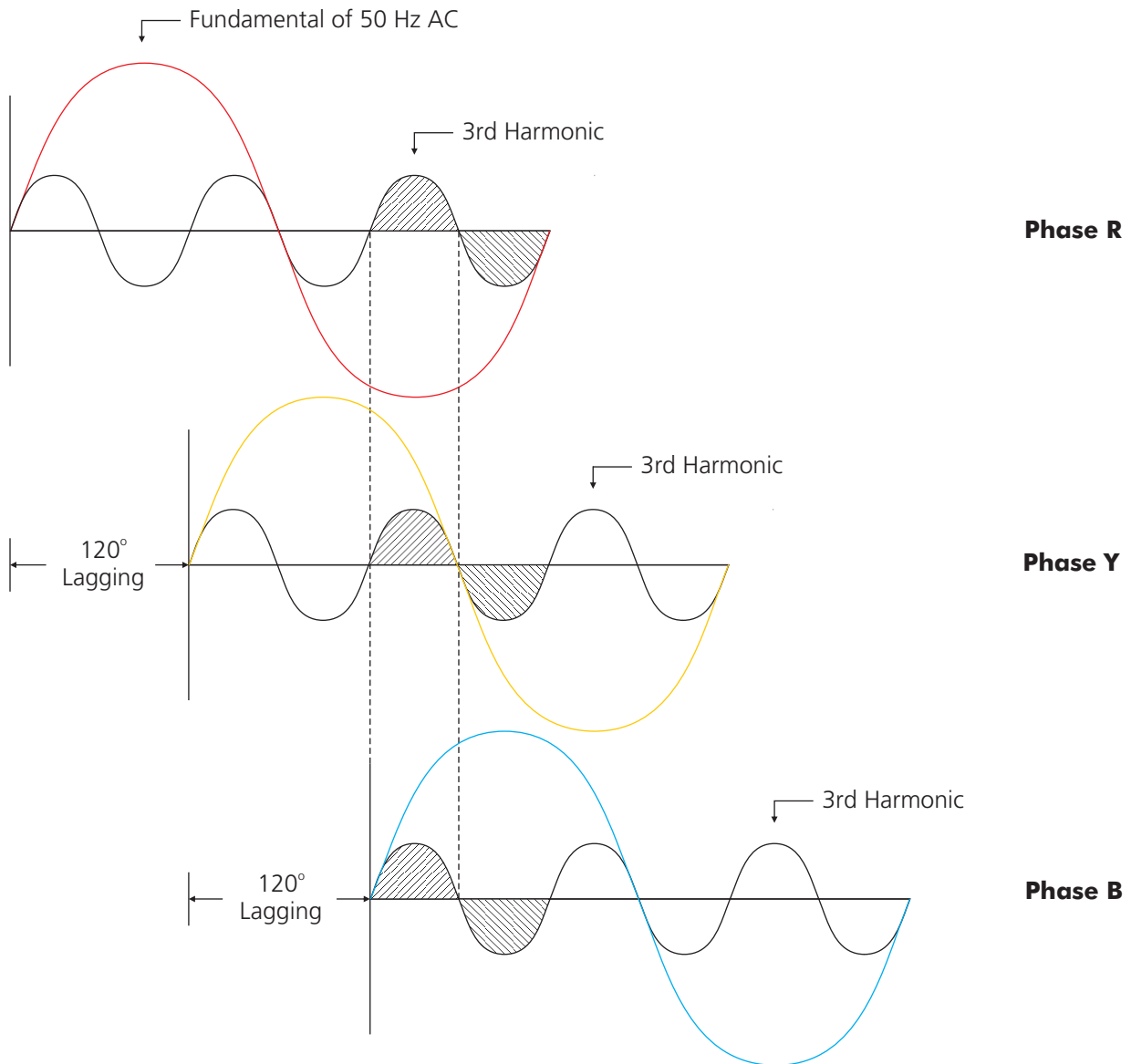

Fig.1

As shown in the Fig.1 any odd triplen harmonic when multiplied by 120 degrees will always produce the product which is integral multiple of the 360 degrees. Thus being shifted by integral multiples of the 360 degrees, the odd triplen harmonics will always be in phase with each other in neutral.

2. Incorrect readings: In case of induction disc W-hr meters and averaging type current meters
3. Additional losses in capacitors and rotating machines
4. Reduced true PF: $Pf = \text{watts}/VA$
5. Transformer overheating especially delta windings where triplen harmonics generated on the load side of a delta-wye transformer will circulate in the primary side. Some type of losses go up as the square of harmonic value (such as skin effect and eddy current losses). This is also true for solenoid coils and lighting ballasts.
6. Zero, negative sequence voltages on motors and generators. In a balanced system, voltage harmonics can either be positive (fundamental, 4th, 7th...), negative (2nd, 5th, 8th...) or zero (3rd, 6th, 9th,...) sequencing values. This means that the voltage at that particular frequency tries to rotate the motor forward, backward, or neither (just heats up the motor), respectively. There is also heating from increased losses as in a transformer.

Harmonic order	1	2	3	4	5	6	7	8	9
Phase Sequence	+	-	0	+	-	0	+	-	0

7. Nuisance operation of protective devices, including false tripping of relays and failure of a UPS to transfer properly, especially if controls incorporate zero-crossing sensing circuits.
8. Bearing failure from shaft currents through uninsulated bearings of electric motors.
9. Blown-fuses on PF correction caps, due to high voltage and currents from resonance with line impedance.
10. Mis-operation or failure of electronic equipment.
11. If there are voltage sub-harmonics in the range of 1-30Hz, the effect on lighting is called flicker. This is especially true at 8.8Hz, where the human eye is most sensitive, and just 0.5% variation in the voltage is noticeable with some types of lighting.

TOTAL HARMONIC DISTORTION:

Power sources act as non-linear loads, drawing a distorted waveform that contains harmonics. These harmonics can cause problems ranging from telephone transmission interference to degradation of conductors and insulating material in motors and transformers. Therefore it is important to gauge the total effect of these harmonics. The summation of all harmonics in a system is known as Total Harmonic Distortion (THD).

Harmonics have frequencies that are integral multiples of the waveform's fundamental frequency. For example, given a 50Hz fundamental waveform, the 2nd, 3rd, 4th and 5th harmonic components will be at 100Hz, 150Hz, 200Hz and 250Hz respectively. Thus, harmonic distortion is the degree to which a waveform deviates from its pure sinusoidal values as a result of the summation of all these harmonic elements.

The ideal sine wave has zero harmonic components. In that case, there is nothing to distort this perfect wave. Total Harmonic Distortion or THD, is the summation of all harmonic components of the current waveform compared against the fundamental component of the current wave:

$$THD = \left[\frac{\sqrt{I_2^2 + I_3^2 + I_4^2 + \dots + I_n^2}}{I_1} \times 100 \right] \%$$

The formula above shows the calculation for THD on a current signal. The end result is a percentage comparing the harmonic components to the fundamental component of a signal. The higher the percentage, the more distortion that is present on the mains signal.

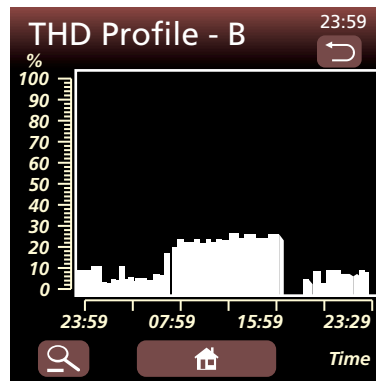

THD PROFILING

Crest Factor (CF):

The Crest Factor of a power source is defined as: $I_{\text{peak}} / I_{\text{RMS}}$

Crest Factor is an important parameter to understand when trying to take accurate measurements of low frequency signals.

$$CF \text{ for sine wave} = 1.414$$

However, the Crest Factor for a non-sinusoidal current waveform can differ dramatically for loads that are not power factor corrected, such as a switching power supply or lamp ballast, which gives a current waveform that is short in duration but high in amplitude.

CF specified in various communication devices QPSK, QAM, WCDMA should be maintained in the system for reliable communication.

Form Factor (FF):

The Form Factor of a power source is defined as: $I_{\text{RMS}} / I_{\text{avg}}$

$$FF \text{ for pure sine wave} = 1.11$$

FF remains independent of the amplitude of the waveform and will remain same for a particular waveform.

Peak Factor (PF):

The Peak Factor of a power source is defined as: $I_{\text{peak}} / I_{\text{avg}}$

All the above power quality indicators are inbuilt in MTX 4.5

Matrix Release System Architecture with Supplementary Modules

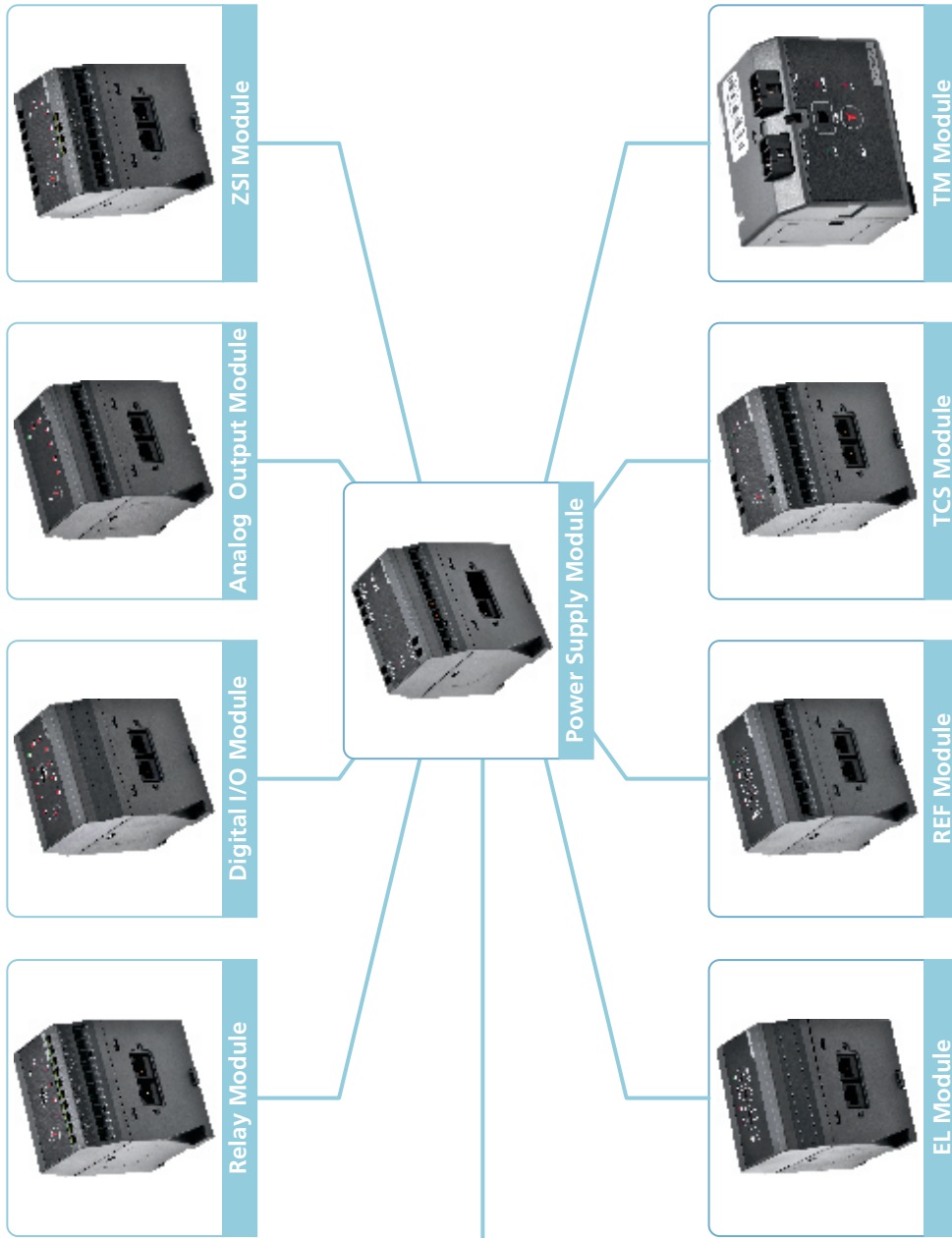

Matrix CAN Architecture

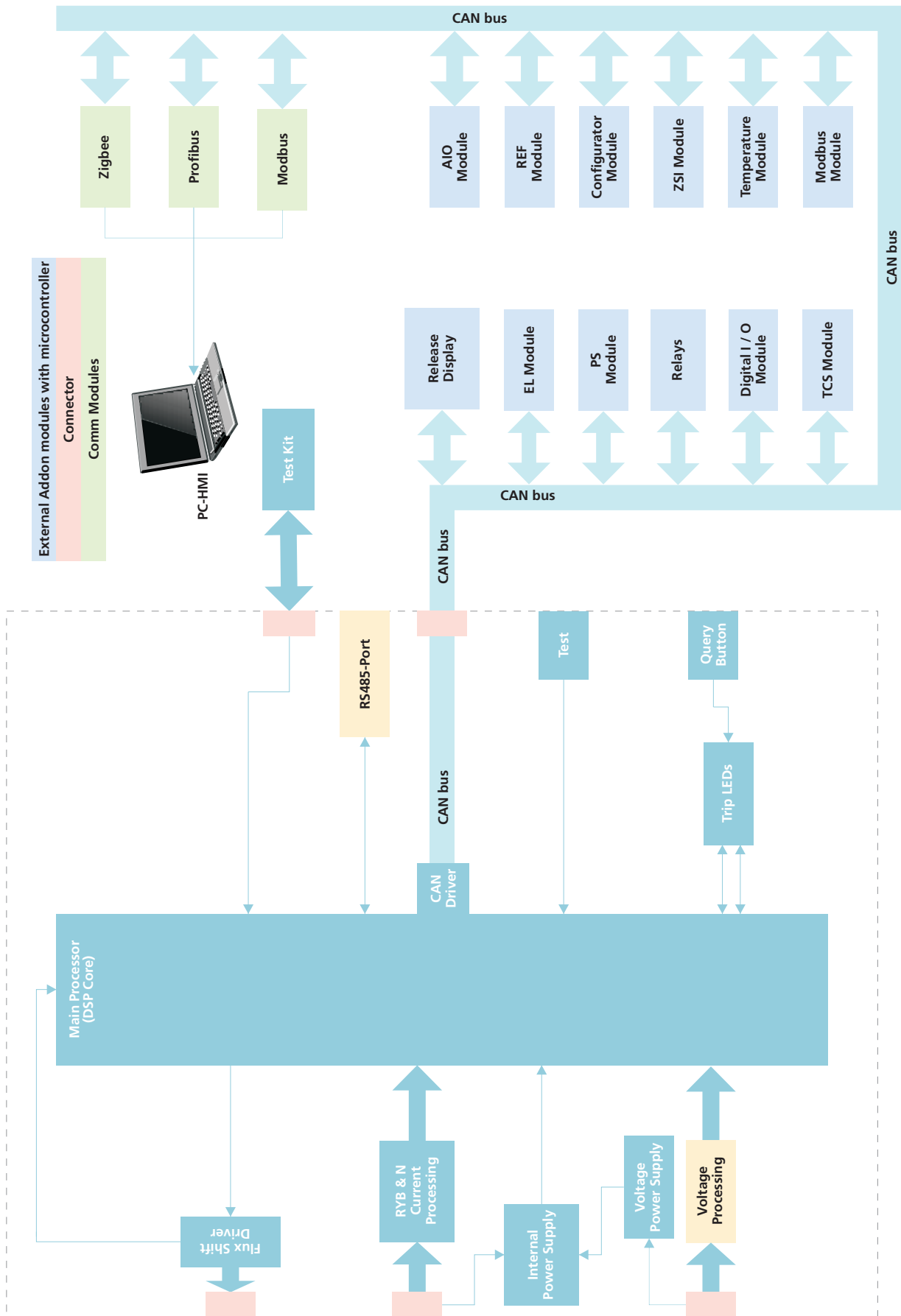

Matrix Protection releases supplementary Modules

UW-MTX 3.5/4.5 releases are backed up by different supplementary modules to enhance the functionality of the Protection & Control Unit to provide customer more advance and complete system protection.

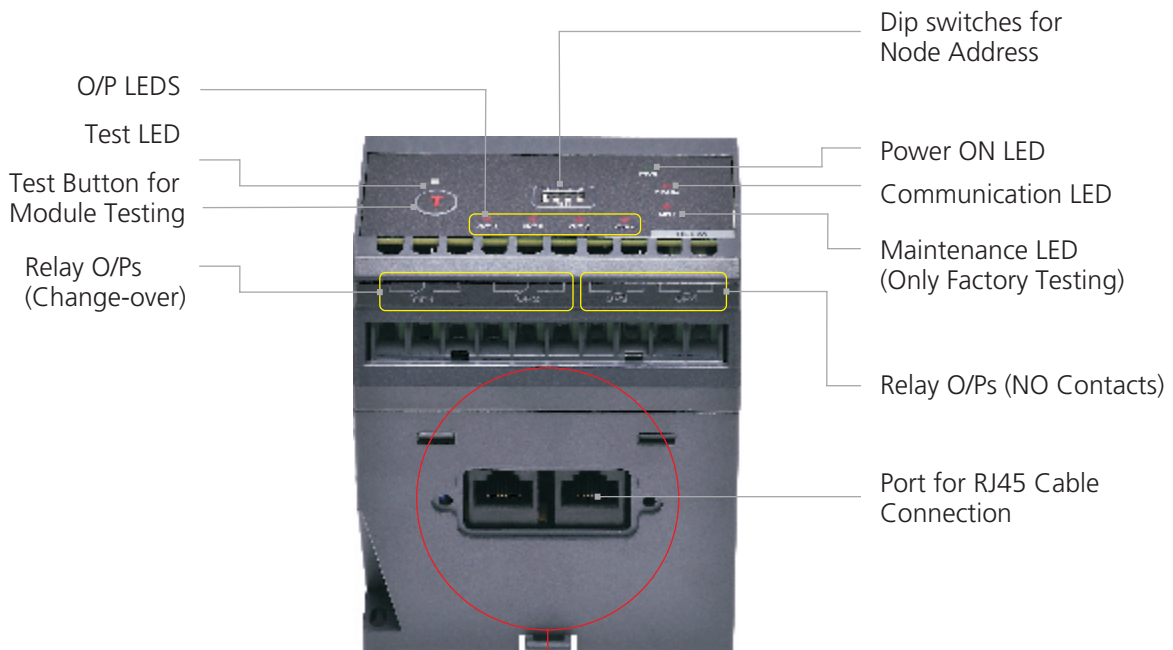

Matrix Modules can be looped with another module using RJ45 modular connectors ensuring reliable and error-free communication, supporting unique CAN bus protocol.

Self Diagnostic Test:

All the modules (Except PS Module) are having self diagnostics test button provided on the front facia. Self test of the supplementary module can be performed by removing the CAN communication connection of the P & C unit with the PS module and 24V DC supply connected (which is looped with the supplementary modules). After test RED led indicates module is not healthy and GREEN indicates module is healthy.

RELAY MODULE

Relay module helps in remote annunciation, interlocking and load management of the system. Relay module consists of four configurable O/Ps (2NO & 2 Changeover) which can be programmed through the release on any of the following protection:

- | | |
|---------------------|------------------------|
| i. Overload | vii. Phase sequence |
| ii. Short circuit | viii. Under voltage |
| iii. Instantaneous | ix. Over voltage |
| iv. Earth fault | x. Under frequency |
| v. Neutral overload | xi. MD (Active) |
| vi. Reverse power | xii. Breaker operation |

Each of the above protection can be programmed for "Trip" mode or "Alarm" mode (Breaker operation can be programmed for breaker ON or breaker OFF mode).

Relay module can also be used for switching off the non-critical loads during the Overload condition so as to prevent the complete shutdown of the system.

Four relay modules can be looped together to one release at a time. Each relay module node address can be set using the dip switches on the module.

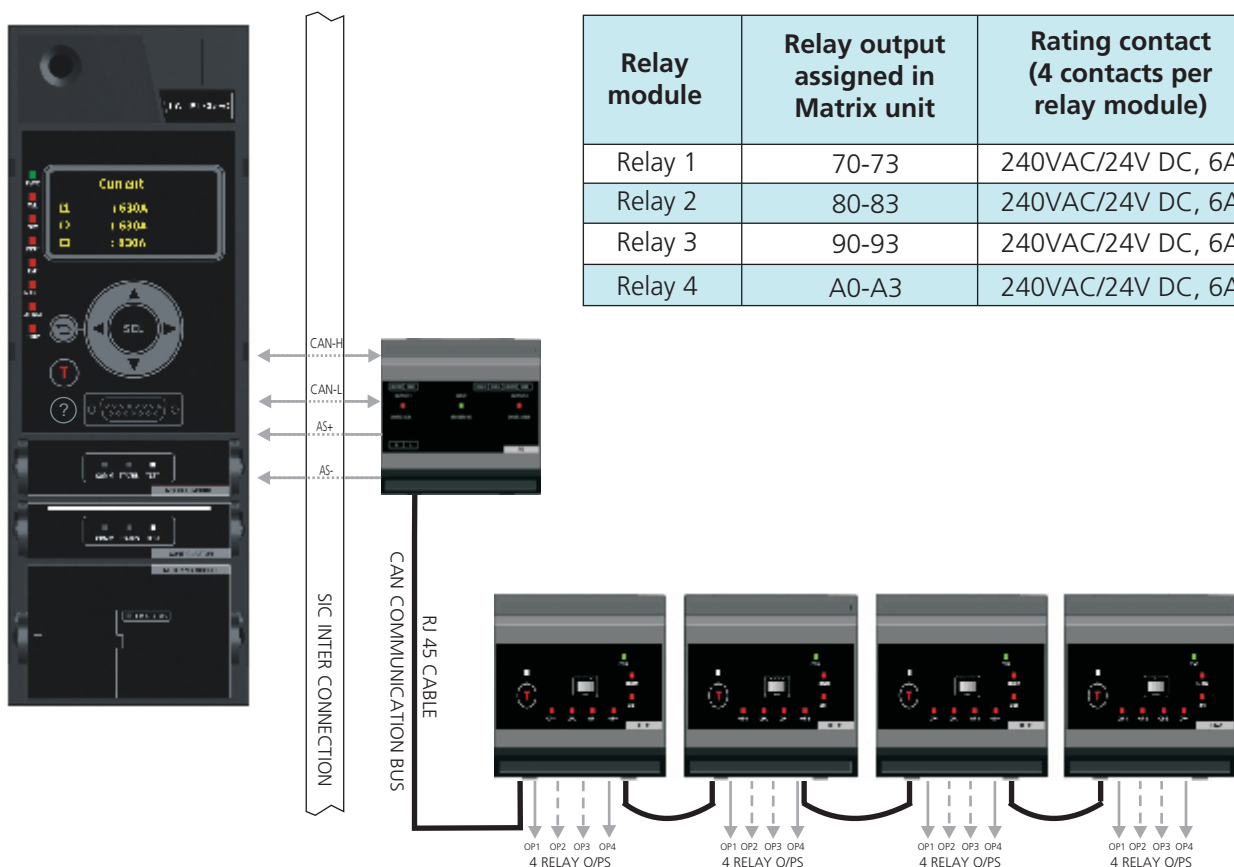

RESTRICTED EARTH FAULT (REF) MODULE

REF protection is usually applied for star winding of Transformer & Generator. Special protection class CTs i.e. Class PS CTs are to be used for achieving the protection. Protection works on differential principle.

REF protection is used to detect and to trip the breaker in the selected zone only i.e. secondary winding of the transformer/generator.

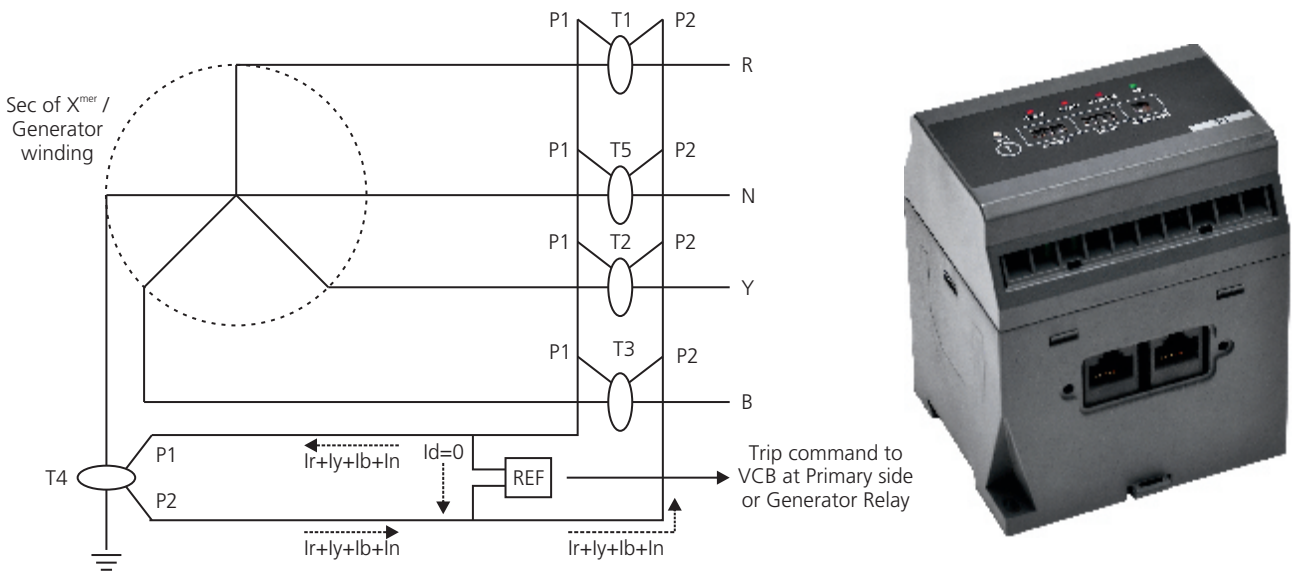

If transformer star node is further used as a neutral in the system, the 5th CT (T5) should be used to avoid the nuisance tripping during the unbalance condition.

During the unbalanced load condition the unbalanced current will flow back through neutral. As the direction of the neutral current is in opposite direction as that of phases, the REF relay will not give nuisance tripping on current unbalance.

In absence of the 5th CT, the breaker will not be able to sense the unbalance condition flowing through the neutral and relay may give trip command.



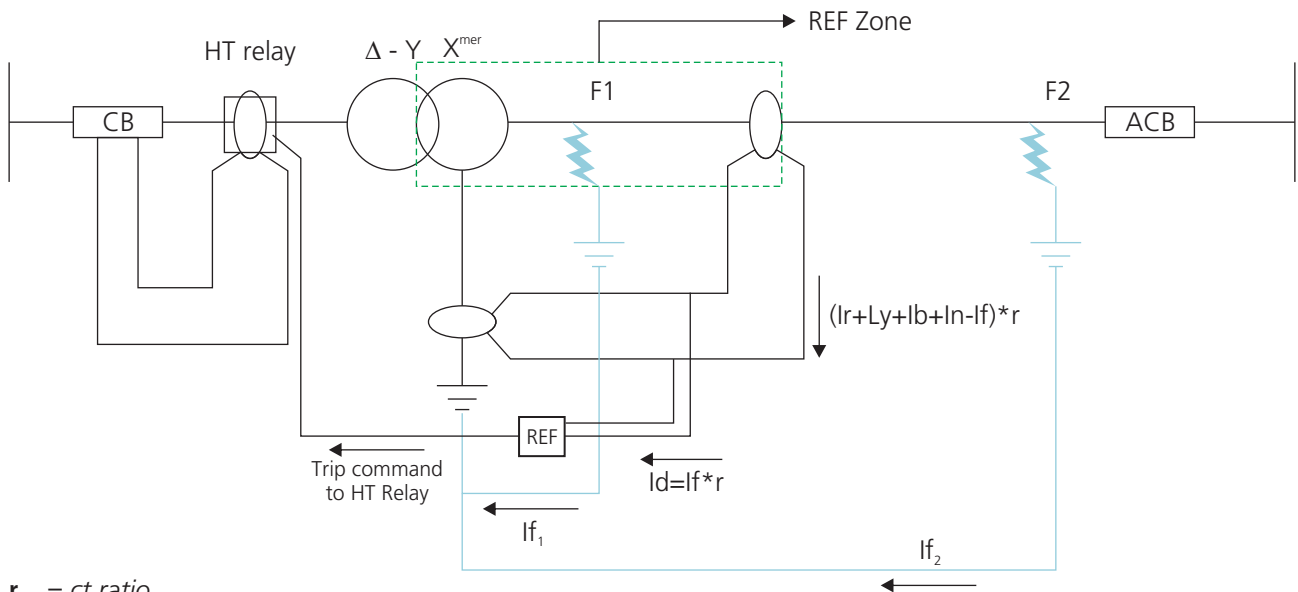

$r = ct \text{ ratio}$

$I_d = \text{deflection current}$

$I_{f1} = \text{fault current @ F1}$

$I_{f2} = \text{Fault current @ F2}$

Case 1. EF inside the restricted zone (F1)

During EF within the zone, current flows back to Xmer star point through neutral sensing CT. The REF module will give trip command to the breaker depending on pickup value.

Case 2. EF outside the restricted zone (F2)

For EF outside the zone, fault current flows through phase CT & neutral CT in opposite direction preventing the nuisance tripping from REF.

ANALOG OUTPUT (AO) MODULE

Analog module can be seen as metering option to other panel display meters.

Four different outputs can be configured for voltage metering or current metering with analog signal output in range of 4-20mA to which analog ammeter and voltmeter can be connected.

4mA corresponds to zero current and voltage while 20mA corresponds to 1.5 times the set I-frame value of current or 1.5 times set Vn value in Matrix release.

AO module communicates on CAN bus protocol with the Matrix Protection and control Unit.

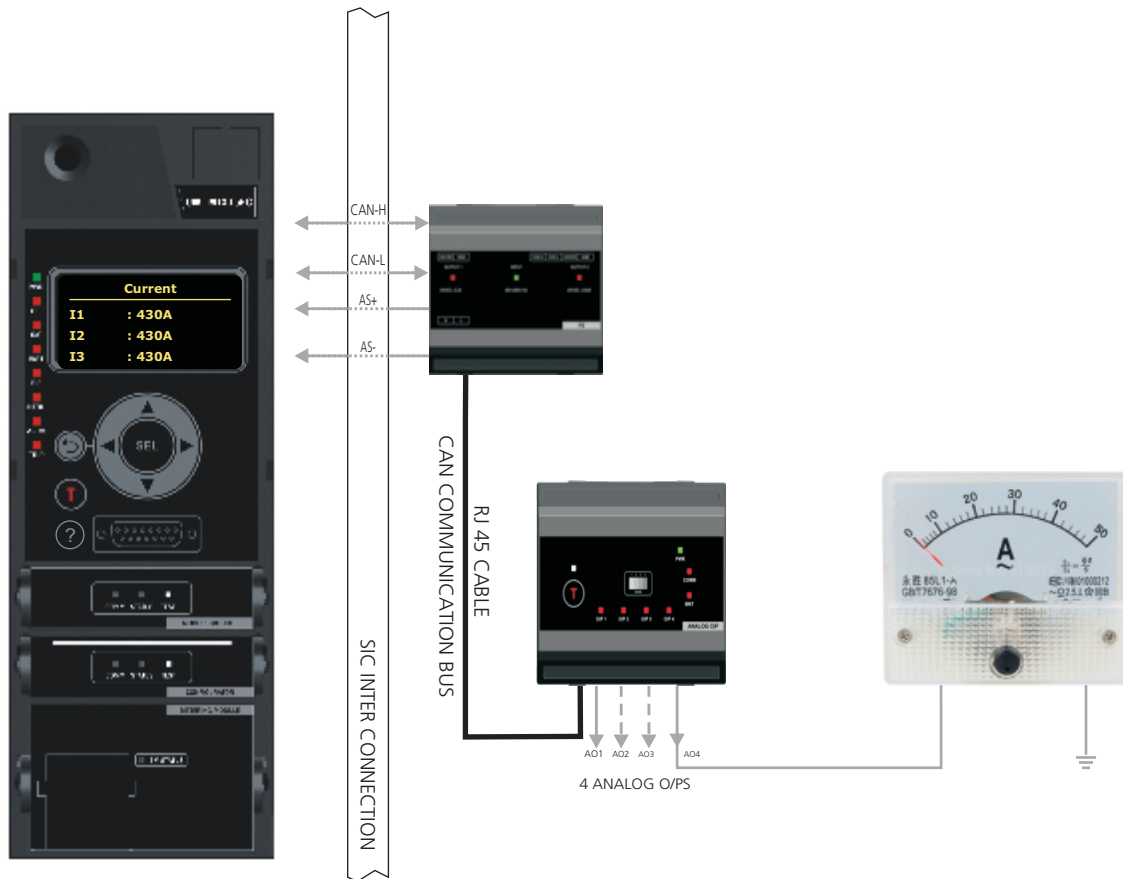

TEMPERATURE (TM) MODULE

Overheating of the Bus-bar can reduce the life of the insulation sleeves, Bus-bar / cables & even Breakers. Periodic loading conditions can cause the metal to heat and cool continuously resulting in the deterioration of the Bus-bar material and loosening of the joints. This becomes even more critical in case if Bus-bars consist of metals of different heat coefficient.

Causes of overheating:

Any of the following reasons can lead to heat generation at the breaker terminal

- i. Improper termination
- ii. Improper Bus-bar design
- iii. Loosen Joints
- iv. De-rating not considered while selection of breaker
- v. Eddy currents

Specifications:

- i. Pick up (T_p) - 85°C to 115°C
- ii. Pre alarm - $0.5T_p$ to $0.95T_p$ in the steps of $0.05T_p$
- iii. Delay - 0 Min to 15 Mins in Steps of 1 Min (It delays the tripping of the breaker by the set delay time.)
- iv. Input supply - 24V DC (Directly at Module Terminals)

Temperature Module senses the real time temperature at the Cradle terminals and displays on the Matrix release screen. TM module can be used to give alarm on the release or to trip the breaker with the temperature pickup range from 85°C to 115°C , which can be configured through Matrix release.

The module is to be fitted on the Breaker and is a factory fitted option.

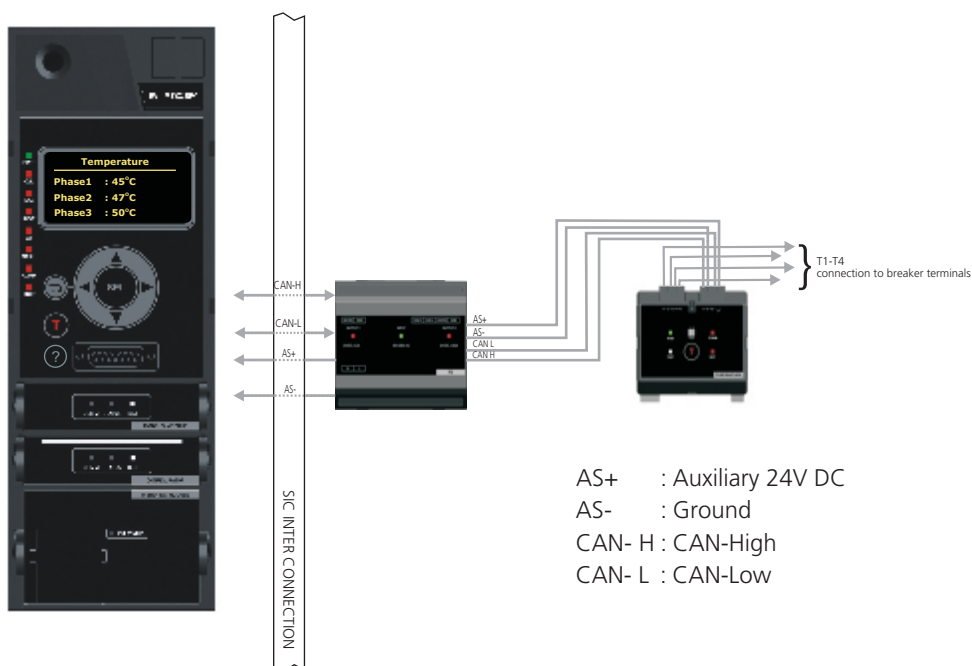

ZSI (Zone Selective Interlocking)

Using the Zone Selective Interlocking feature of the Matrix releases, intelligence can be imparted into the electrical system for the quick trip and isolation of the fault element of the system.

For ZSI feature, P&C units are hardwired as shown and they communicate with each other through restraining signals. In ZSI active mode, time delays in short circuit and earth fault are set progressively higher towards the main incomer ACB.

In the given diagram, ACB 1 has the highest delay of 400ms for short circuit. ACB 2 and ACB 3 are having delays 200ms, 100ms respectively. For fault at Y, ACB3 will send restraining signal to ACBs 1 & 2 and hence pre-set delays are honored. ACB 3 will trip in 100ms and the fault will be cleared.

ACB 2, ACB 3 will remain closed, for faults at immediate locations like X, there will be no restraining signal from feeder breakers ACB 2, ACB 3 and hence ACB1 will Issue Trip command immediately instead of Pre-set 400ms delay.

MTX Releases of OMEGA provides two type of options for achieving Zone Selective Interlocking (ZSI)-

1. ZSI through MTX1Gi & MTX1.5Gi

MTX1Gi & MTX1.5Gi are having inbuilt ZSI. Wiring for ZSI to be done directly through SICs of ZSI (available at SIC Block-6 & marked in yellow color).When MTX1Gi /1.5Gi Releases are used in Downstream with an External Matrix ZSI module in Upstream, an additional 24V DC Supply needs to be connected to the SIC at AS+/AS- of SIC Block 6.

ZSI Wiring Cable Specification and compatibility with other Releases & ZSI Module is mentioned in below Tables.

2. ZSI through External Module with MTX3.5 & above

ZSI Module for Releases MTX3.5 & above is available as an accessory. This module provides optional upgrade to Zone Selective Interlocking (ZSI)

ZSI feature provides:

- Discrimination for Short-Circuit & Earth Fault protection
- CAN Bus protocol for communication in ZSI Module
- Support 20 downstream & 3 upstream Omega ACB
- Provision for self-diagnostics Test

Note: Input supply 24V DC, Need to be applied directly on Terminals of ZSI Module

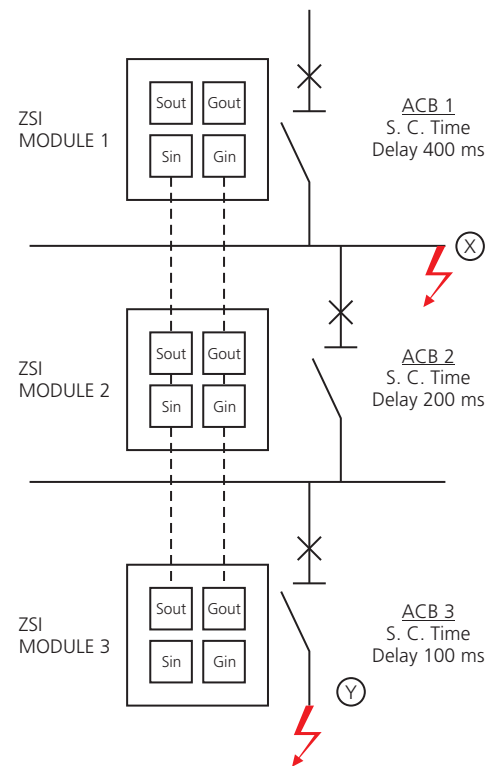

ZSI Cable Specification	
Description	PVC sheathed shielded twisted pair wire
Size	7/0.2 tinned copper
Shield	Braided tinned copper ID: 4.6 max
Impedance	Approx. 76 Ohm/km at 200 MHZ
No. of Twists	Approx. 11 twists / ft.

ZSI Compatibility Chart				
MTX Releases		Releases in Upstream		
		MTX1Gi	MTX1.5Gi	MTX3.5 & above with ZSI Module
Releases in Downstream	MTX1Gi	✓	✓	*
	MTX1.5Gi	✓	✓	*
	MTX3.5 & above with ZSI Module	✓	✓	✓

✓ Compatible
 * Compatible-Additional External 24V DC Supply to be provided at AS+/AS- of SIC Block-6



ZSI Contacts on SIC Block-6 (Marked in Yellow)

EARTH LEAKAGE (EL) MODULE

In industrial installations, the current leakage can happen to earth because of the following main reasons:

- i) Current leakage through phase to earth insulations
- ii) Leakage of current through phase to earth leakage capacitance

Due to the high insulation resistance the leakage current magnitude remains low in terms of milliamps or micro amps. Assuming that the phase-to-earth insulation resistance in an LV network is just 1 Mega-ohm(*), then the leakage current to earth will be $(240V/1 \text{ Mega-ohm})$ 240 microamperes. But, generally the phase-to-earth insulation resistance would be much higher than just 1Mega-ohm, normally a few tens or even hundreds of Mega-ohms. Thus, the leakage current to earth will be a further fraction of the micro-ampere or even nano-amperes. As human body's sensible current is more than 1 milli-ampere, this remains un-sensed by a human being coming in contact with the earthed frame of an LV electrical installation.

Any leakage current above 300mA can result into fire in electric installations. In Industrial areas especially in mining application the earth leakage protection becomes critical for the fire safety.

Omega Matrix Earth Leakage module has Earth leakage current monitoring range of 300mA to 30A. The EL module communicates on CAN bus with the Matrix releases which can be set in Alarm, Trip or "Both" mode.

Some more features of EL module:

- "NO" contact for external indications (24V DC/240V AC, 6A)
- Standalone module
- Dip switches for configuring pickup and delay settings
- Self-diagnostic check for module healthiness check



**As per Indian Electricity rule, 1956, Rule No. 48(ii) For Medium & Low Voltage Installations, Voltage at a pressure of 500 V applied between each live conductor and earth for a period of one minute, the insulation resistance of medium and low voltage installations shall be at least 1 Mega ohm.*



DIGITAL INPUT OUTPUT (DIO) MODULE

Matrix DIO module is provided with 4 digital inputs and 4 digital outputs for the implementation of various Boolean logic equations into the system.

Some features of DIO module

- Up to 4 DIO modules can be looped together to one MATRIX release
- Dip switches on the Module facia for setting the node address
- 16 different logic equations can be assigned
- Self-diagnostic test provision

Contact Ratings	
Input contacts	24V DC or 240V AC
Output Contacts	24V DC or 240V AC, 6A (resistive load)

TRIP CIRCUIT SUPERVISION (TCS) MODULE

TCS module of Matrix Releases continuously monitors the healthiness of the shunt trip coil irrespective of the breaker operational position. Protection can be set in both, trip or alarm mode in the release unit.

- Detects circuit breakage, contact degeneration in connections, resistance increase in wires, contacts and coils of the supervised shunt release
- Complete range of rated voltage (24-415V) either AC or DC
- Standalone module
- Self-diagnostic test provision



POWER SUPPLY (PS) MODULE

PS module is used to power ON other supplementary modules of OMEGA Matrix release family as well as to communicate on the CAN bus through RJ45 shielded cable.

Specifications	AC	DC
Input	85-265V	125-300V
Output 1*	-	200mA @ 24V DC
Output 2	-	650mA @ 24V DC

Note : For VA burden details of modules & optimal usage of PS modules refer Matrix User's manual

* For using Output 1, Output 2 should be loaded first

Modbus:

Modbus Module is used for the Configuration, Monitoring and Control of Matrix releases and its supplementary modules.

It offers Client/Server communication in RTU mode.

Configuration function:

- 1) Unit Settings
- 2) System Settings
- 3) Protection Settings Group 1
- 4) Protection Settings Group 2
- 5) Module Settings

Monitoring function:

- 1) Metering Data – Voltage, Current, Power, Energy, Power Factor, Online Module Status
- 2) Status Data – Alarm & Trip Status, Digital Input Output Module & Relay Module Status
- 3) Record Data – Trip Records, Event Records, Maintenance Records

Control function:

- 1) Commands for Set group Change, Restore Factory Defaults, Clear Maximum Demand
- 2) Maximum Current value, Maximum Voltage Value and Energy, Open and Close Circuit
- 3) Breaker, Maintenance Acknowledgement and Earth Fault (EF) test

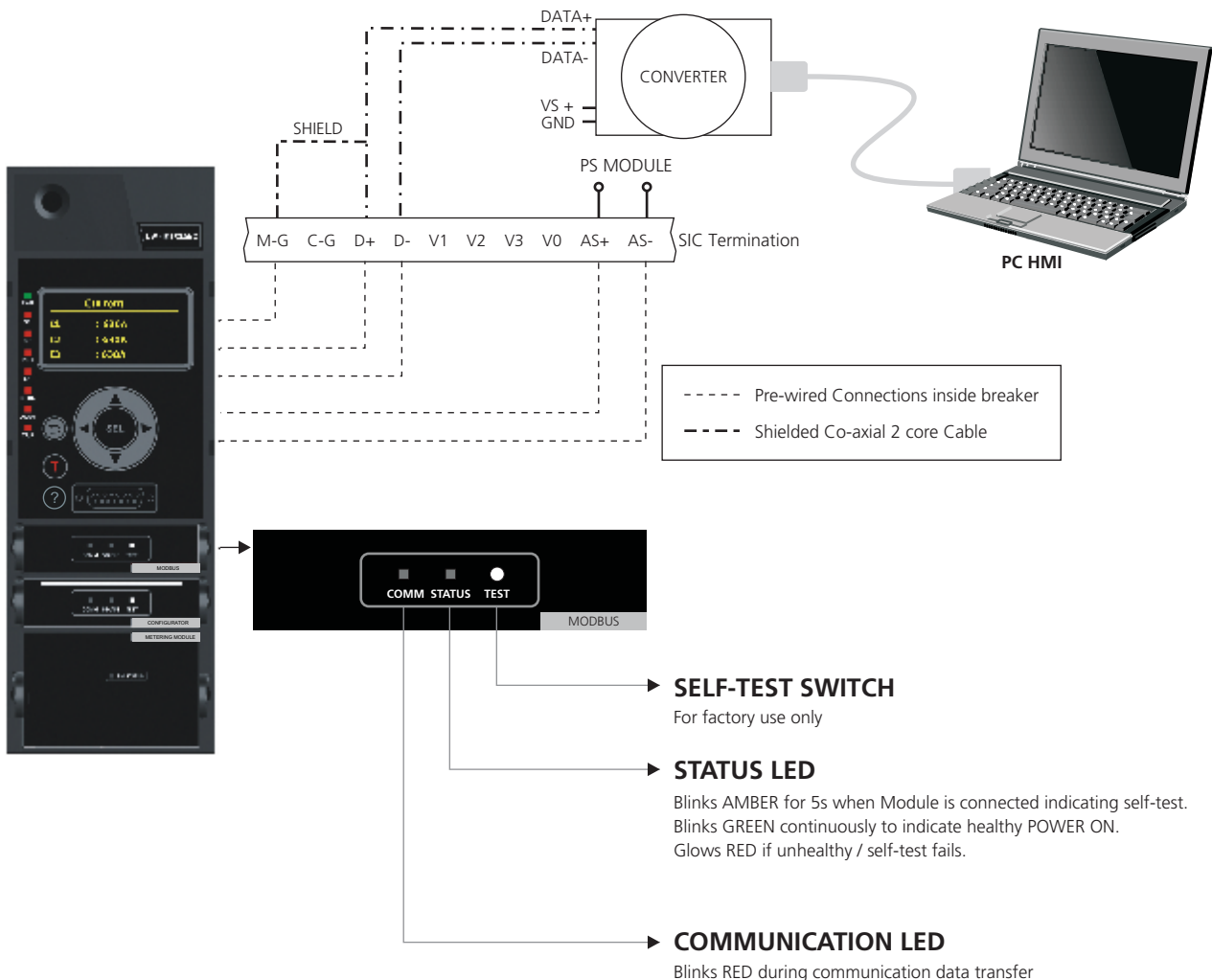

Profibus:

Profibus Module supports PROFIBUS DP V0 slave protocol. This module communicates with PROFIBUS Class 1 and/or Class 2 Master.

GSD file should be used/loaded in PROFIBUS master for understanding the device functions. Network termination switch is provided at the rear end of the module. Thus this module can be used as end node in the network.

It communicates on baud-rates 9.6Kbps, 19.2Kbps, 45.45Kbps, 93.75Kbps, 187.5Kbps, 500Kbps, 1.5Mbps, 3Mbps, 6Mbps, 12Mbps. It automatically detects the baud-rate selected by PROFIBUS master for communication.

PROFIBUS module is used to monitor and configure critical status parameters of Matrix Release like Pick-up, Alarm and Trip status.

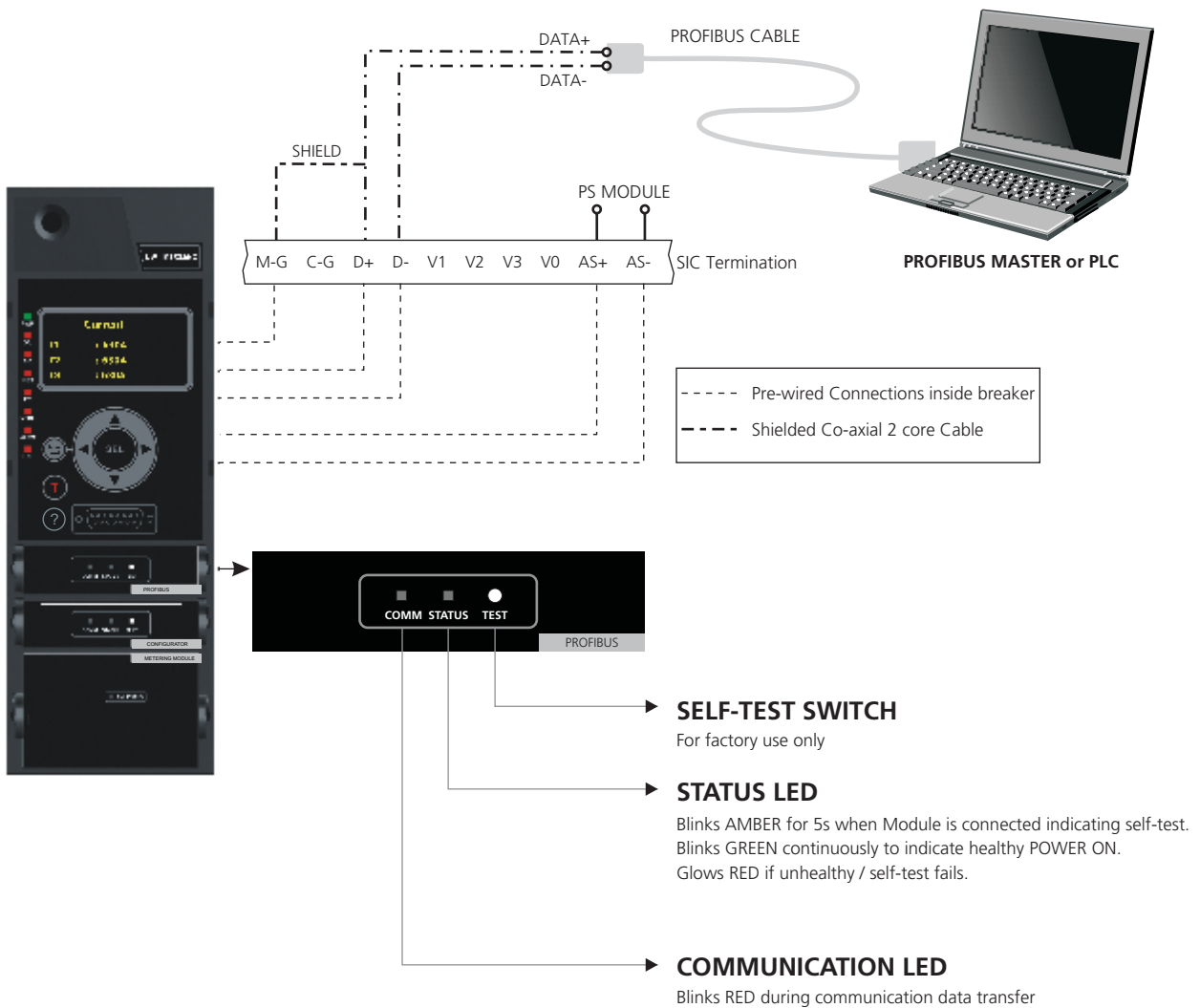

Zigbee:

Our innovative Matrix releases are designed to let consultants & system designers help their customers & end-users gain greater control of, and improve their everyday business & industrial processes by means of “ZigBee wireless communication” capability.

UW-MTX3.5/3.5EC/4.5 provides Wireless Communication using ZigBee protocol formulated under IEEE 802.15.4 standard for Wireless Personal Area Network (WPANs). Zigbee operates in ISM radio bands of 2.4GHz.

The Communication range is 200m Line Of Sight (LOS) with over the air data rates upto 250 Kbps. Zigbee module is used for Monitoring parameters of Matrix releases and its supplementary modules.

Monitoring function:

- 1) Metering Data – Voltage, Current, Power, Energy, Power Factor, Online Module Status
- 2) Status Data – Alarm & Trip Status, Digital Input Output Module & Relay Module Status
- 3) Record Data – Trip Records, Event Records, Maintenance Records

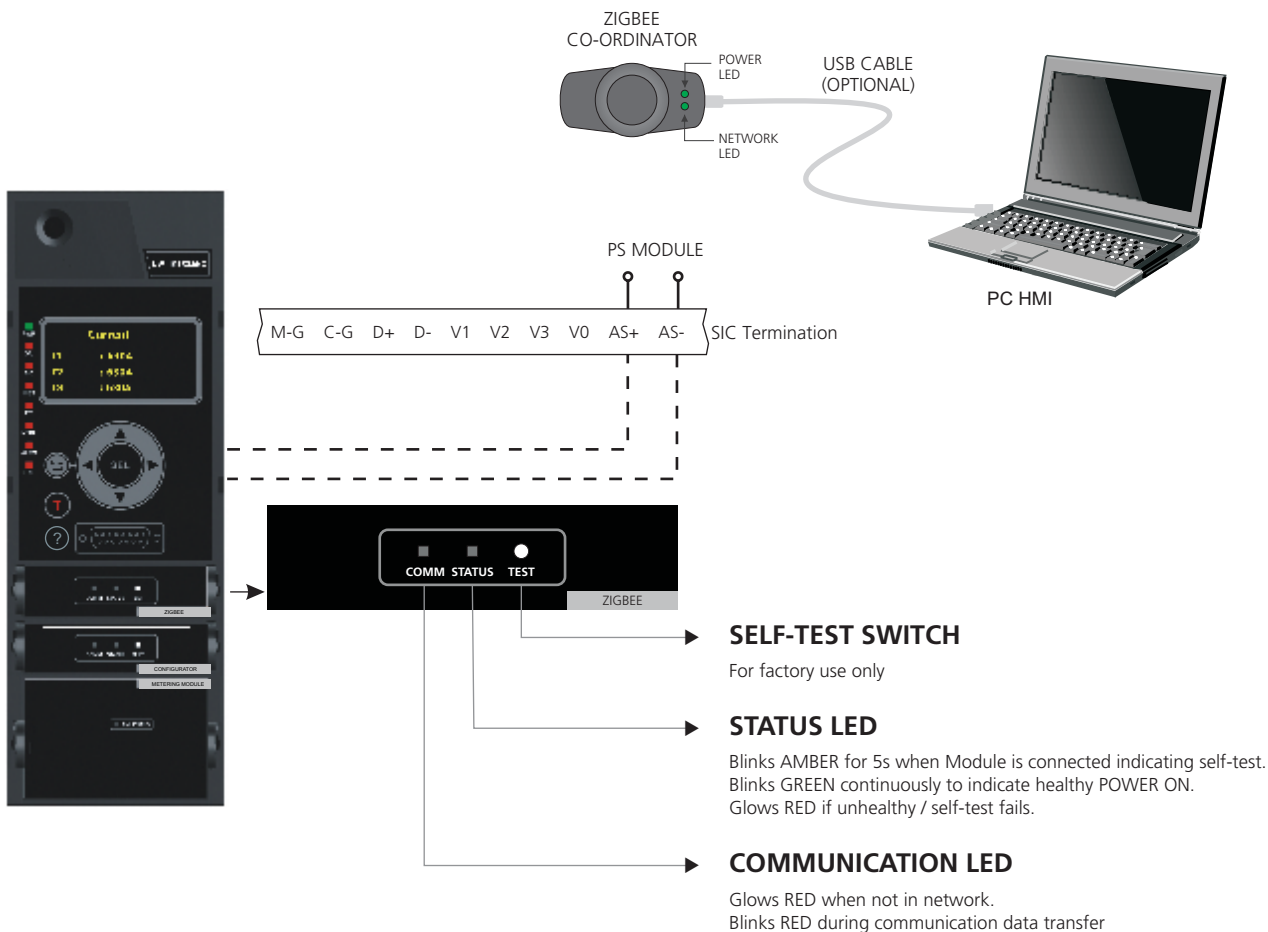

Note:

- 1) It is necessary to first switch on the Co-ordinator module and form a network. Co-ordinator Module can be directly plugged in the PC USB port or USB cable can be used.
- 2) Power LED on Co-ordinator Module will glow GREEN when connected to the port. Network LED on Co-ordinator module will glow GREEN when it forms a network.
- 3) Zigbee Module should be now inserted in the Matrix P&C unit .

Smart Configurator:

UW-MTX3.5/3.5EC/4.5 has an optional Smart Configurator Module which is used for easy parameterisation of the release. In large electrical installations, where many ACBs are in use; one can copy the release protection parameters setting on smart card and then copy the parameters on various releases. Smart Configurator Module in MTX releases with its ease of use can reduce the gestation period of electrical installation.

Smart Configurator works on the principle of RF interface at 106kbps between the module and the Smart Card.

The following operations can be performed on the Smart Card:

- 1) Write File: Copy files from the release to the card
- 2) Read File: Copy files from the card to the release
- 3) Delete File: Delete selected file from the card
- 4) Format Card: Delete all the files from the card and format it

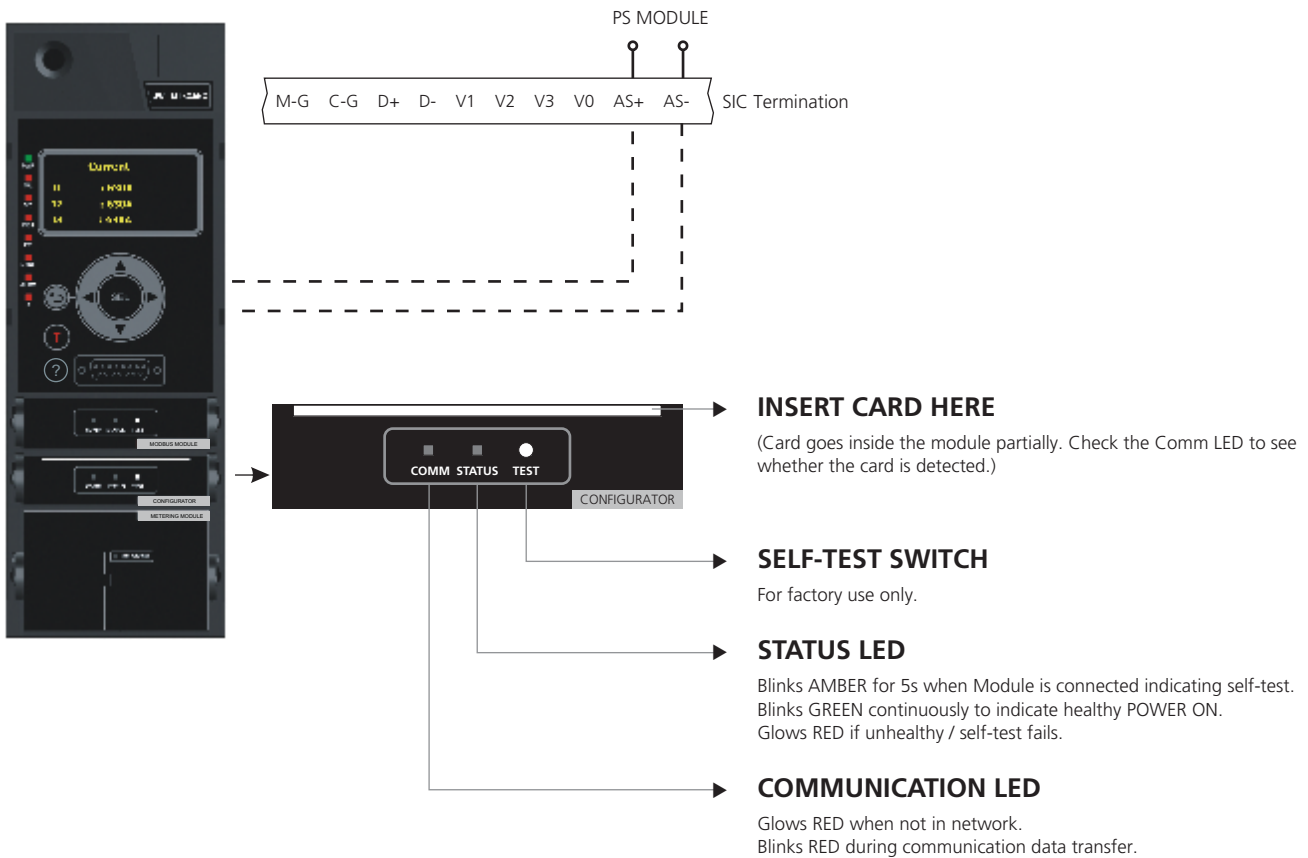

Trip Oscillograph

MTX 4.5 gives user the unique advantage of analyzing the post fault waveforms of the system. After the fault, the system waveform gets captured in the release with the trip timing and the waveform deformation of voltage and current of the individual phases. The data remain stored in the memory of the release so as to empower the user to check the speed and the correctness of the protection system, as well for further power system analysis.

Some of the unique points of the MTX4.5 Trip Oscillograph are:

- 300ms record with 10 cycles before and 5 cycles after the trip/pickup of fault
- 15 cycle record useful to monitor and analyze the current and voltage disturbances
- 4x zoom

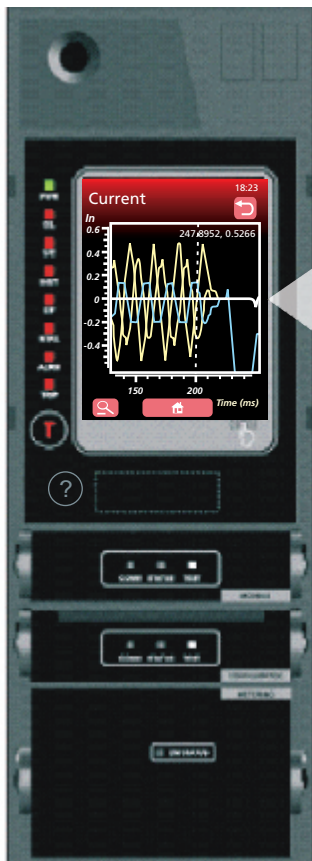

MTX4.5

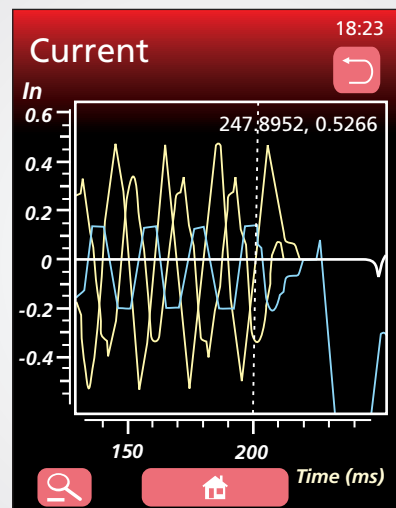

Menu Navigation Overview for UW-MTX 3.5/3.5EC/3.5H

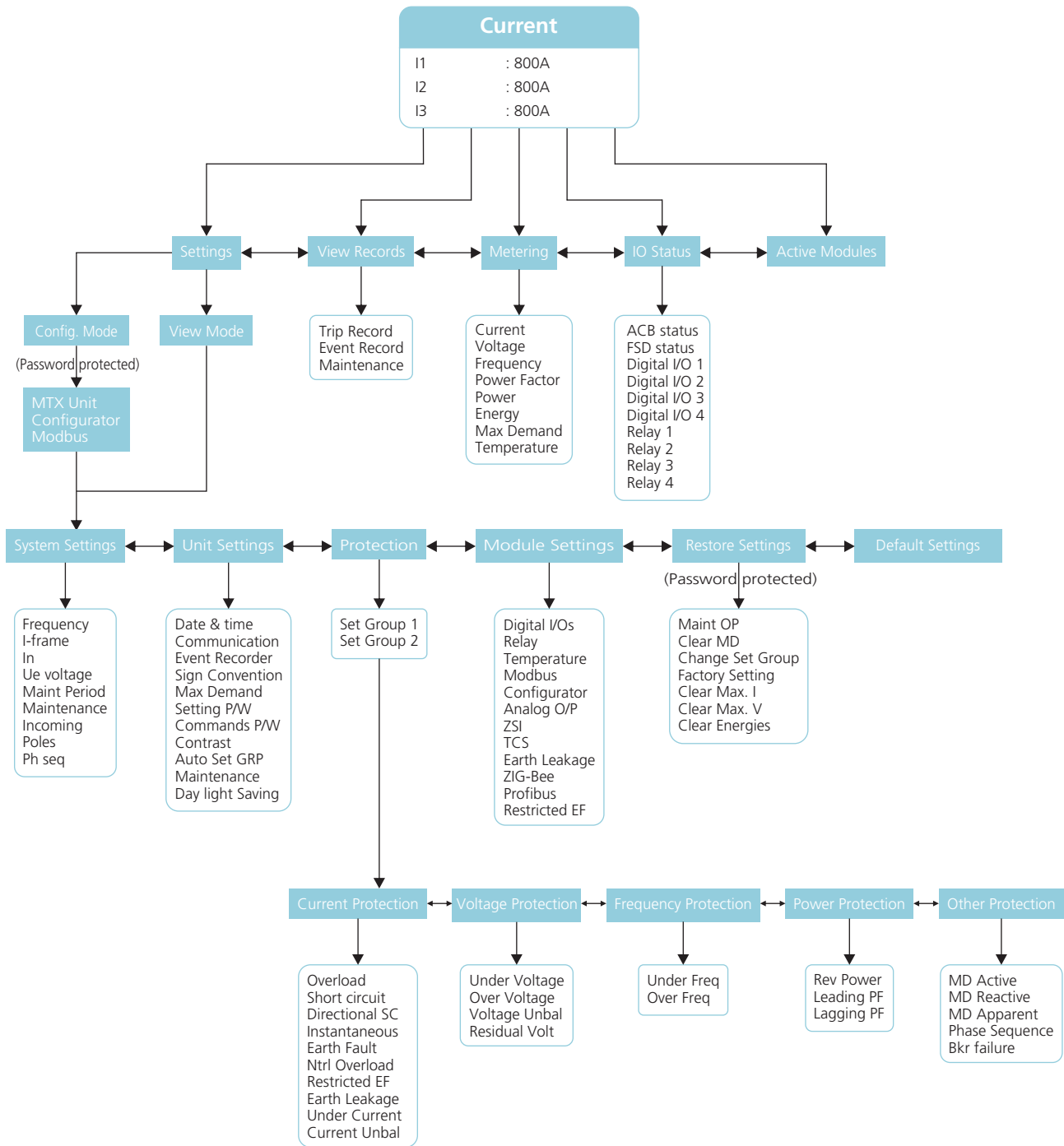



- SmartComm is a state-of-the-art SCADA-based unified software platform for device communication, integration, data acquisition, data management, monitoring & control and preemptive and predictive data analysis.
- Omega ACBs can be integrated with smartcomm.
- SmartComm supports a wide range of devices and protocols. It can expand its functionality to address the growing requirements of the installation

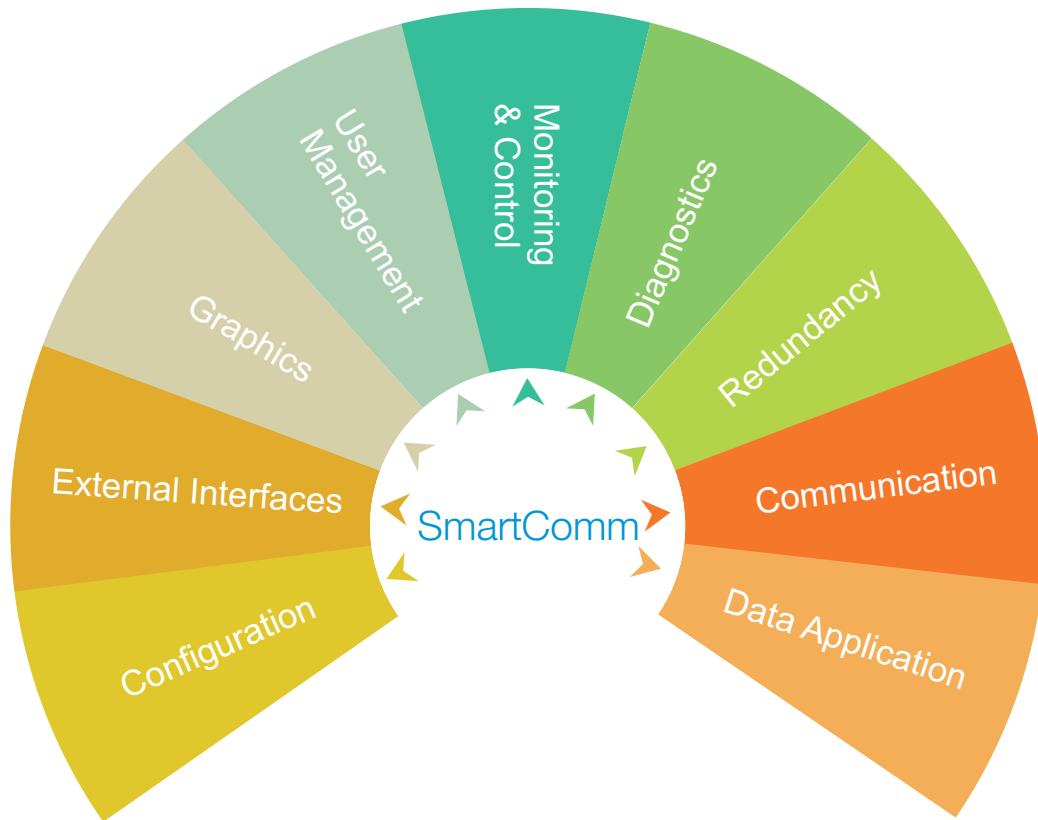

Omega ACBs - Integration with SmartComm brings a host of benefits:

- Omega ACBs integrated with SmartComm enable users to perform various configuration, monitoring and measurement tasks remotely
- Real-time communication for monitoring, control and diagnostics. The system also provides facility of alarms, event-alerts and acknowledgements
- Enables user to get immediate reports and swiftly initiate corrective action, if required
- Remotely control and monitor the circuit breaker from centralized location.
- Get 'trip info' details such as cause of tripping, date and time stamping of tripping and fault event history.
- Monitor ACB terminal temperature along with real-time trending and Over-temperature annunciation.
- Undertake time-based harmonic monitoring and analysis for the complete plant.
- Implementing dual set group for intelligent selection of protection settings based on Real Time Clock.
- Plan and schedule maintenance to reduce energy and operation cost.
- View instantaneous parameters like voltage, current, power factor etc. at a single location.
- SmartComm can be configured to e-mail reports and SMS critical alerts.
- Communication through multiple protocols and drivers like Modbus TCP/IP, Modbus RTU, BACnet.

Accessories

**Breaker
Accessories**

**Cradle
Accessories**

Accessories

Breaker Accessories

- ▶ Auxiliary Contact Block
- ▶ Shunt Release (SR)
- ▶ Closing Release (CR)
- ▶ Under-Voltage Release (UVR)
- ▶ Electrical Charging Device (ECD)
- ▶ Operation Counter
- ▶ Micro-switches for electrical indications:
 - ✓ Common fault indication
 - ✓ Under-Voltage release trip indication
 - ✓ Shunt release trip indication
 - ✓ Spring charging indication
 - ✓ Ready to close indication
- ▶ Locking 'OFF' Button (LOB)
- ▶ Shroud for ON-OFF Button

Cradle Accessories

- ▶ Electrical Position Indication (EPI)
- ▶ Door-Interlock
- ▶ Door-Racking Interlock
- ▶ Locking in all Positions
- ▶ Locking in Disconnected Position
- ▶ Safety Shutter
- ▶ Arc-Shield
- ▶ Rating Error-Preventer

Miscellaneous

- ▶ Breaker Maintenance Cover
- ▶ Ingress Protection Cover
- ▶ Mechanical Interlock
- ▶ Terminal Adaptors
- ▶ Neutral Configurator
- ▶ External Neutral CTs

Breaker Accessories:

Modularity, the key design aspect of OMEGA ACBs facilitates the quick fixing & removal of several breaker mounted accessories such as CR, SR, UVR, Auxiliary contact blocks & various indicating micro-switches. These accessories are located on the front top-side of breaker mechanism & have specified positions.

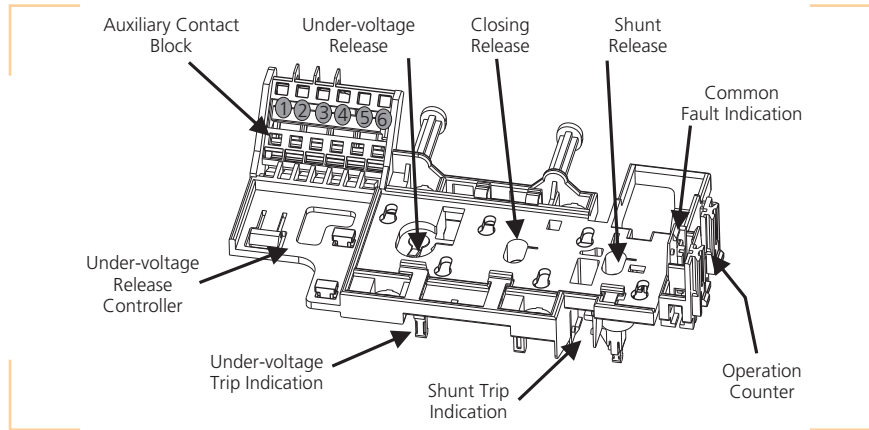

- 1) Auxiliary Contact Block:** Auxiliary Contact Block contains the change-over switch contacts in combination of 4 units of 1NO+1NC each. Auxiliary contact block reflects the breaker ON/OFF state in control circuit.

Operational voltage (Ue)	upto 24V	110V	220/230V	400V
In (AC-12) at 50/60 Hz	10A	10A	10A	10A
In (AC-15) at 50/60 Hz	6A	6A	6A	4A

Operational voltage (Ue)	24V	40V	110V	220V
In (DC-12)	10A	8A	3.5A	1A
In (DC-13)	10A	4A	1.2A	0.4A

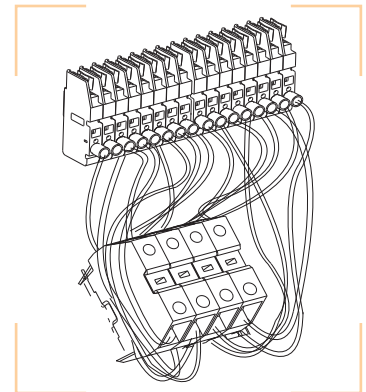

- 2) Shunt Release (SR):** Shunt Release when energized opens the breaker instantaneously. Omega ACBs offer general purpose Shunt Release which can reliably trip the Circuit Breaker through external trip command.

Operational voltage (Ue)	Power consumption	Operating range
110, 240, 415V AC at 50/60Hz	200VA for 0.5 sec	70-110% of Ue
24, 30, 48, 60, 110, 125, 220, 250V DC	200W for 0.5 sec	70-110% of Ue

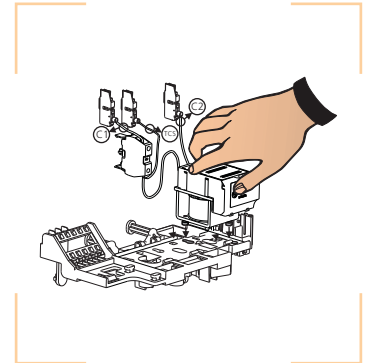

- 3) Closing Release (CR):** Closing Release remotely closes the Circuit Breaker if the spring mechanism is already charged. Closing Releases in Omega Air-circuit breakers come with inbuilt Electrical anti-pumping feature. Inbuilt electrical anti-pumping feature prevents auto-reclosing of Circuit Breaker on faults. Anti-pumping relay cancels the persistent closing signal after successful completion of the closing operation.

Operational voltage (Ue)	Power consumption	Operating range
110, 240, 415V AC at 50/60Hz	200VA for 0.5 sec	85-110% of Ue
24, 30, 48, 60, 110, 125, 220, 250V DC	200W for 0.5 sec	85-110% of Ue

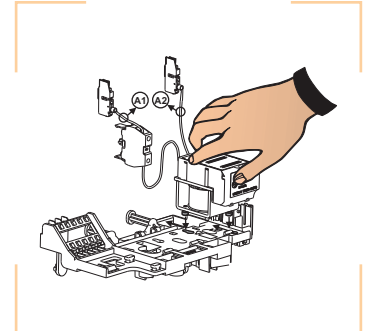

4) Under-voltage Release + Delay Module (UVR): The Under-voltage Release causes the Circuit Breaker to open if the operational voltage falls to a value between 35% and 70% of its rated voltage or not applied. UV Release mechanically locks the closing of breaker & it makes it impossible to close the Circuit breaker, either manually or electrically. The Circuit breaker can be closed with operation voltage of 85-110% of its rated value.

UV Release can be used for monitoring the voltage in the primary (power circuit) or secondary (control circuits) circuits or can be used for electrical interlocking scheme (for DG synchronization, paralleling of transformers etc). In order to avoid the nuisance tripping of the circuit breaker during short voltage dips, UV release comes with the UV-delay module. Operation of UVR can be delayed between 0 to 5 secs. in steps of 0-1-3-5 sec.

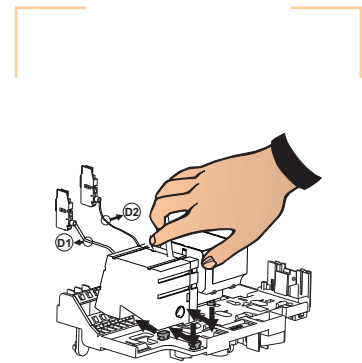

Type	Normal Voltage	Short-time Power Consumption	Operating Limit
UVR (Delay Setting-0,1,3 & 5 sec)	110, 220, 240, 415 V AC 50Hz / 60Hz	200 VA max, 3s	85 - 110%
	24, 30, 48, 110, 220 V DC	200 W max, 3s	

5) Electrical Charging Device (ECD): Electrical Charging Device automatically charges the closing springs of the circuit breaker operating mechanism. After Circuit Breaker closing operation, the geared motor immediately recharges the closing spring. Thus instantaneous re-closing of the circuit breaker is possible following opening operation. The closing springs can also be charged manually (using the spring-mechanism charging handle) in the event of an auxiliary power supply failure or during maintenance work.

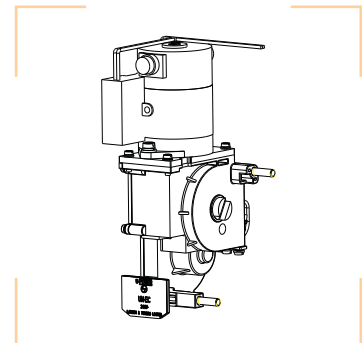

Operational voltage (Ue)	Power consumption	Operating range
110, 240, 415V AC at 50/60Hz	300VA for 1 sec	85-110% of Ue
24, 30, 48, 60, 110, 220, 250V DC	300W for 1 sec	85-110% of Ue

6) Operation Counter: The Operation Counter indicates the number of operating cycles the Circuit breaker has been subjected to and it is visible on the Circuit breaker front-facia. It is compatible with manual and electrical control functions. Counter readings serve as a guide for maintenance & inspection.

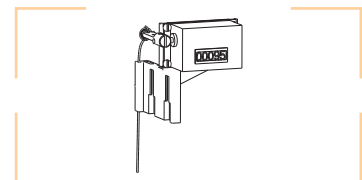

7) Micro-switches for electrical indications:

- a. **Common Fault Indication (CFI):** CFI provides the electrical indication of circuit breaker tripping due to operation of protection & control unit.
- b. **Under-Voltage Release Trip Indication:** Under-voltage Release Trip Indication micro-switch provides electrical indication of circuit breaker tripping with the operation of under-voltage release.
- c. **Shunt Release Trip Indication:** Shunt Release Trip Indication micro-switch provides electrical indication of circuit breaker tripping with operation of shunt release.
- d. **Spring Charging Indication:** Spring Charging Indication micro-switch provides the electrical indication whether main mechanism spring is charged or not.
- e. **Ready-To-Close Indication (RTC):** RTC takes into account all the safety parameters that are part of the control & monitoring system of electrical installation. OMEGA RTC allows the circuit breaker to close only if following conditions are met:

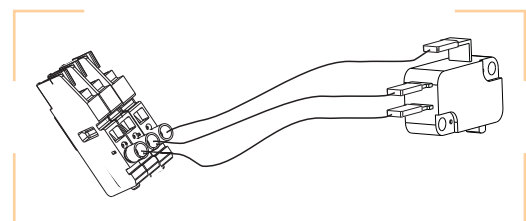

- ✓ Main spring is charged
- ✓ Circuit Breaker is OFF
- ✓ Shunt release is de-energized
- ✓ Under-Voltage release is energized
- ✓ All Arc-chutes are properly placed
- ✓ Mechanical trip indication lever on release is reset
- ✓ Racking shutter is closed

- 8) Lockable Trip Push Button (LTPB/LOB):** LOB locks the breaker in OFF position by continuously pressing the OFF push button. Lock defeats all the positive closing signals (mechanical or electrical) coming to the breaker and thus prevents the nuisance closing of the breaker. Locking 'OFF' button (LOB) can be implemented using C-Type / R-Type of locks. The locks are designed in such a way that the keys cannot be removed out till the breaker is locked (OFF button pressed). Locking of the breaker in OFF position ensures safety of the maintenance person working on downstream equipment. Locking 'OFF' button (LOB) can be used to design the interlocking schemes with other devices in the system.
- 9) Shroud for ON-OFF Button:** Transparent shroud blocks the access to the ON/OFF push-buttons used to open and close the breaker. It prevents inadvertent or unauthorized operation of the ON or OFF button. It's possible to independently lock the ON/OFF push button with the help of ON-OFF button shroud & mechanical lock. It can be pad-locked with lock hasp of 6mm diameter.

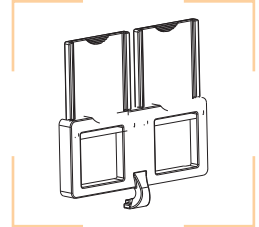

Cradle Accessories:

- 1) Electrical Position Indication (EPI):** Secondary Isolating Contact (SIC) blocks on ACB cradle assembly facilitates the electrical indication for the exact position of the breaker within the cradle. 3 SIC contacts electrically indicates the Connected / Test / Disconnected positions of breaker.
- 2) Door-interlock:** Door-interlock inhibits the opening of door if ACB is in Test or Service position. Door-interlock can be mounted on either side of the cradle (LHS or RHS).

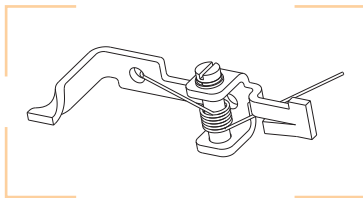
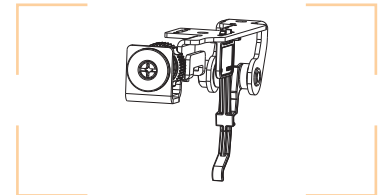

- 3) Door-racking interlock:** Door-racking interlock prevents the racking-in operation of the breaker if panel door is open.

- 4) Racking Shutter Pad-lock:** Racking Shutter Pad-lock inhibits the access to the racking mechanism such that racking handle cannot be inserted to rack-in/rack-out the breaker. Racking Shutter Pad-lock is an inbuilt feature with Omega ACBs. It can be pad-locked with lock hasp of 6mm diameter.
- 5) Safety Locks:** Any of C-Type, R-Type locks can be used for locking the ACB in "Any position"/"Isolated position" & locking "OFF" push button, for interlocking with other electrical devices in the control scheme of the system.

C-Type

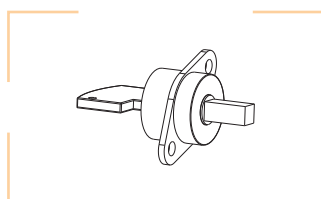

R-Type

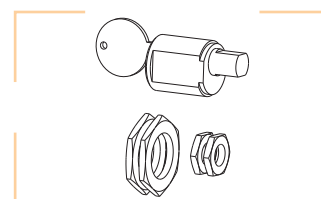

- 6) **Locking in Disconnected position:** Locking in Isolated/Disconnected position inhibits the undesirable racking-in operation of the breaker from the isolated position. Locking in isolated position can be implemented using C-Type, R-Type locks. Locking of the breaker in disconnected position ensures safety of the maintenance person working on downstream equipment. The locks are designed in such a way that the keys cannot be removed out till the breaker is locked, at the same time the breaker cannot be locked in "Service/Connected" or "Test" positions. Locking in Disconnected position can be used to design the interlocking schemes with other devices in the system.
- 7) **Locking in all positions:** Locking in all positions facilitates the locking of breaker in Connected/Test or isolated positions. Locking in all positions can be implemented using C-Type, R-Type locks.
- 8) **Safety Shutter:** The fixed part (cradle) of withdrawable Circuit Breaker contains safety shutters for preventing inadvertent access to live terminals of Circuit Breaker when breaker is withdrawn from the cradle. Safety shutters can be locked in closed position using pad-lock devices.
- 9) **Arc-shield:** Arc-shield helps in reducing the vertical clearance between two ACBs in vertical tier panels from 300mm to mere 45mm*. Arc-shield facilitates in compact design of switchboards
- 10) **Rating Error-Preventer:** Rating Error-Preventer ensures that the breaker of proper rating goes with the cradle of corresponding rating. It is made up of two sub-assemblies one on the cradle and other one on the breaker. Rating Error-Preventer offers distinct combination for a particular breaking capacity version within a particular rating of the breaker. Rating Error-Preventer comes as an inbuilt feature with Omega ACBs.

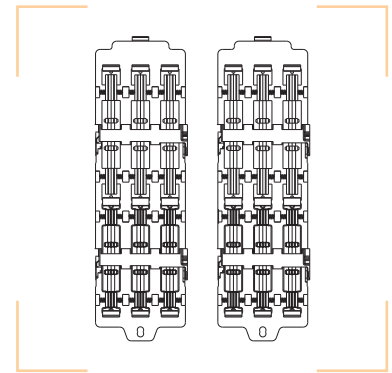

Miscellaneous Accessories:

- 1) **ACB Maintenance Cover:** Using Cover, panel door can be covered during maintenance at site to prevent the entry of dust or foreign material in the panel enclosure and cradle. The same can be fitted on the bezel without any tool and is common for fix and draw-out version of OMEGA ACB.

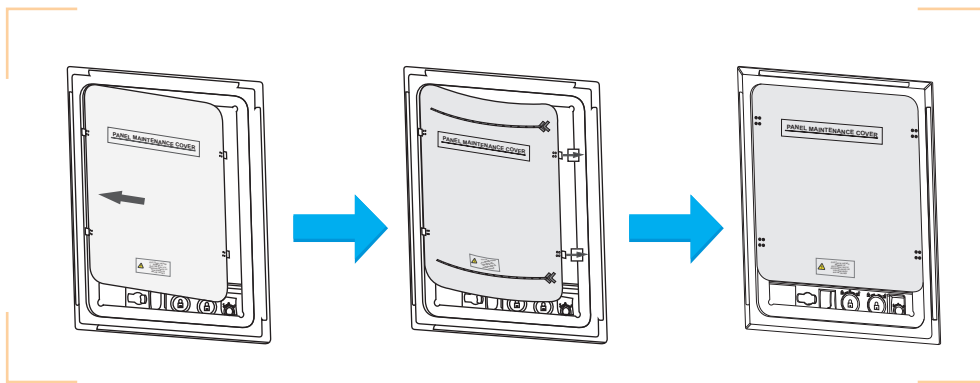

- 2) **Ingress Protection Cover:** A transparent safety cover mounted on the door-sealing frame on panel door increases the Ingress Protection (IP) of the ACB from IP53 to IP54. Safety cover can be mounted in Left hinge / Right hinge combinations.

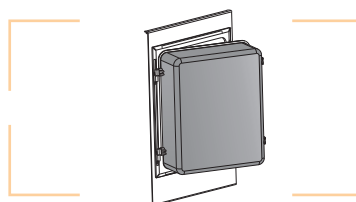

* In case of Temperature Module mounted on the Cradle this dimension should be 70 mm.

3) Mechanical Interlock : Mechanical Interlock is used for interlocking breakers as per the desired control scheme. It can interlock up to three Omega ACBs of Fixed/Draw-out/Mixed version. The breakers can be interlocked in Vertical or Horizontal configuration.

Cable length: 2/3/5 meter, minimum radius at cable bend: 70mm

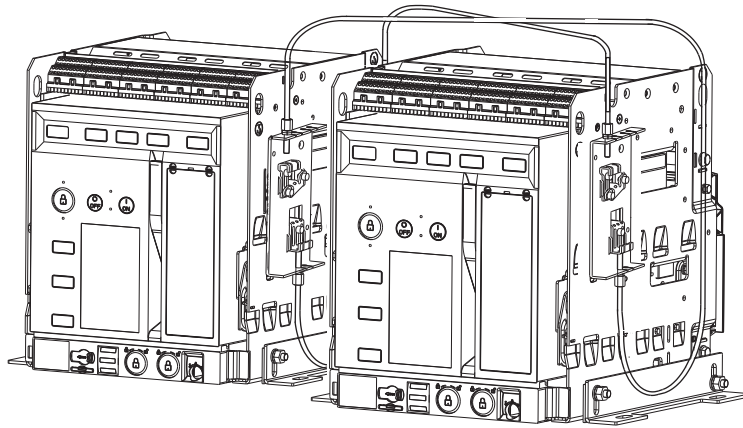

Possible mounting arrangements:

Type of Interlock	Typical Circuit	Interlocks Possible	Schematic Diagram																					
Two Incomers (2 I/C)		<table border="1"> <tr><td>A</td><td>B</td></tr> <tr><td>O</td><td>O</td></tr> <tr><td>I</td><td>O</td></tr> <tr><td>O</td><td>I</td></tr> </table>	A	B	O	O	I	O	O	I														
A	B																							
O	O																							
I	O																							
O	I																							
Three Incomers (3 I/C)		<table border="1"> <tr><td>A</td><td>B</td><td>C</td></tr> <tr><td>O</td><td>O</td><td>O</td></tr> <tr><td>I</td><td>O</td><td>O</td></tr> <tr><td>O</td><td>I</td><td>O</td></tr> <tr><td>O</td><td>O</td><td>I</td></tr> </table>	A	B	C	O	O	O	I	O	O	O	I	O	O	O	I							
A	B	C																						
O	O	O																						
I	O	O																						
O	I	O																						
O	O	I																						
Two Incomers & One Standby (2 I/C + 1 S/B)		<table border="1"> <tr><td>A</td><td>B</td><td>C</td></tr> <tr><td>O</td><td>O</td><td>O</td></tr> <tr><td>I</td><td>O</td><td>O</td></tr> <tr><td>O</td><td>I</td><td>O</td></tr> <tr><td>I</td><td>O</td><td>O</td></tr> <tr><td>O</td><td>O</td><td>I</td></tr> </table>	A	B	C	O	O	O	I	O	O	O	I	O	I	O	O	O	O	I				
A	B	C																						
O	O	O																						
I	O	O																						
O	I	O																						
I	O	O																						
O	O	I																						
Two Incomers & One BusCoupler (2 I/C + 1 B/C)		<table border="1"> <tr><td>A</td><td>B</td><td>C</td></tr> <tr><td>O</td><td>O</td><td>O</td></tr> <tr><td>I</td><td>O</td><td>O</td></tr> <tr><td>O</td><td>I</td><td>O</td></tr> <tr><td>O</td><td>O</td><td>I</td></tr> <tr><td>O</td><td>I</td><td>O</td></tr> <tr><td>I</td><td>O</td><td>O</td></tr> </table>	A	B	C	O	O	O	I	O	O	O	I	O	O	O	I	O	I	O	I	O	O	
A	B	C																						
O	O	O																						
I	O	O																						
O	I	O																						
O	O	I																						
O	I	O																						
I	O	O																						

O - Breaker Open **I** - Breaker Closed

4) Terminal Adaptors :

OMEGA ACBs offer wide variety of terminal adaptors for both Fixed & Draw-out versions. Terminal Adaptors facilitate ease of termination of both Copper & Aluminium busbars.

Terminal Adaptors for Draw-out Version: Frame-1 : 400 - 2000A

Termination side dimensions (T)		
Hole distance	Thickness	No. of holes
27	15	2

Frame size	Configuration	Height
Fr-1	400-2000A	Vertical / Horizontal
		65

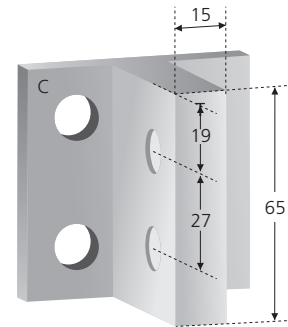

All dimensions are in mm
For ordering cat nos please refer page no.80

Frame-1 : 2500A, Frame-2 : 400 - 3200A,

Termination side dimensions (T)		
Hole distance	Thickness	No. of holes
27	20	3

Frame size	Configuration	Height
Fr-1	2500A	Vertical
Fr-2	400 - 3200A	Vertical / Horizontal
		98

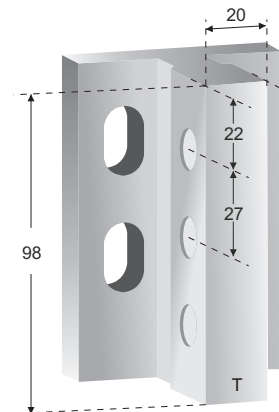

All dimensions are in mm
For ordering cat nos please refer page no.80

Frame-2 : 4000A

Termination side dimensions (T)			
Configuration	Hole distance	Thickness	No. of holes
Horizontal	27	32	3
Vertical	27	20	5

Frame size	Configuration	Height/Width
Fr-2	4000A	Horizontal
		100
Fr-2	4000A	Vertical
		150

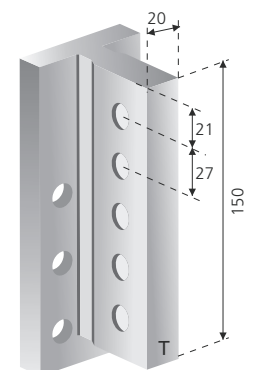
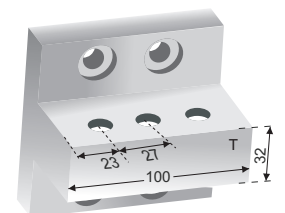

All dimensions are in mm
For ordering cat nos please refer page no.80

Frame 3 : 400 - 4000A

Configuration	Termination side dimensions (T)		
	Hole distance	Thickness	No. of holes
Horizontal	27	15	6
Vertical	27	15	4

Frame size		Configuration	Height/Width
Fr-3	4000A	Horizontal	165
Fr-3	4000A	Vertical	125

All dimensions are in mm
For ordering cat nos please refer page no.80

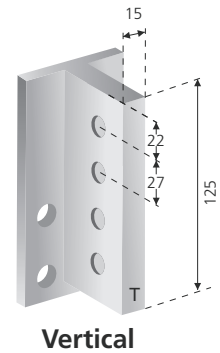
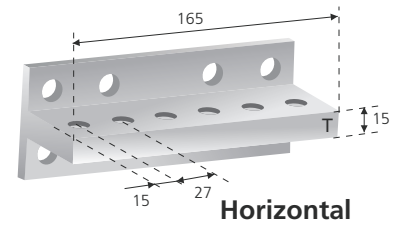
**Frame-3 : 5000A**

Configuration	Termination side dimensions (T)		
	Hole distance	Thickness	No. of holes
Horizontal	27	20	6
Vertical	27	20	4

Frame size		Configuration	Height/Width
Fr-3	5000A	Horizontal	165
Fr-3	5000A	Vertical	125

All dimensions are in mm
For ordering cat nos please refer page no.80

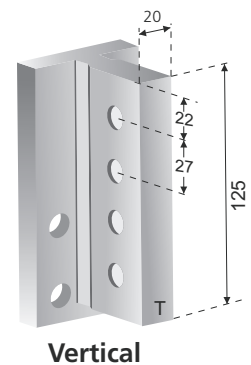
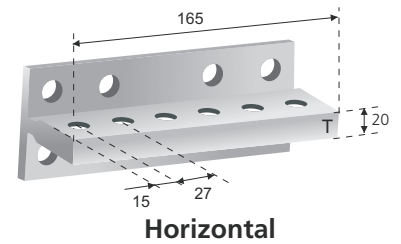
**Frame-3 : 6300A**

Termination side dimensions (T)		
Hole distance	Thickness	No. of holes
27	20	5

Frame size		Configuration	Height
Fr-3	6300A	Vertical	150

All dimensions are in mm
For ordering cat nos please refer page no.80

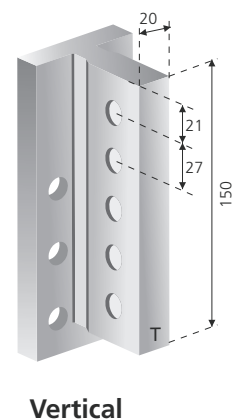

Terminal Adaptors for Fixed Version:

Frame-1 : 400 - 2000A N/S

Termination side dimensions (T)		
Hole distance	Thickness	No. of holes
27	15	2

Frame size	Configuration	Width
Fr-1	400 - 1600A	Vertical / Horizontal
		65

All dimensions are in mm
For ordering cat nos please refer page no.80

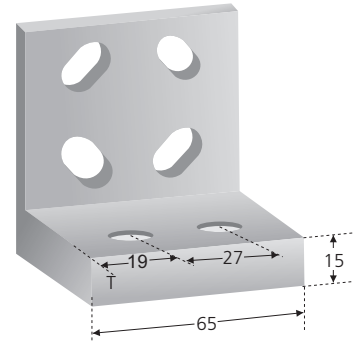

Frame-1 : 400 - 2000A H, & Frame-3 : 400 - 4000 H/V

Termination side dimensions (T)		
Hole distance	Thickness	No. of holes
27	15	2

Frame size	Configuration	Width
Fr-1 S	2000A	Vertical / Horizontal
Fr-1 H	400 - 2000A	Vertical / Horizontal
Fr-3 H/V	400 - 4000A	Vertical / Horizontal
		65

All dimensions are in mm
For ordering cat nos please refer page no.80

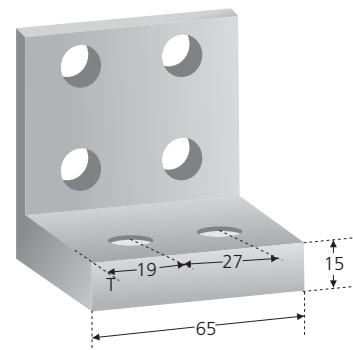

Frame-1 : 2500A S/H & Frame-3 6300A H/V

Termination side dimensions (T)		
Hole distance	Thickness	No. of holes
27	20	3

Frame size	Configuration	Width
Fr-1 S/H	2500A	Vertical
Fr-3 H/V	6300A	Vertical
		100

All dimensions are in mm
For ordering cat nos please refer page no.80

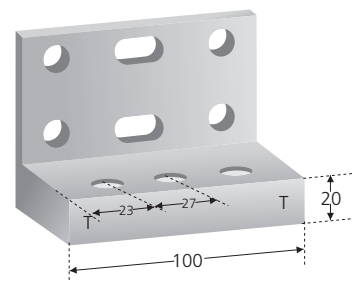

Frame-2 : 400 - 2500A N/S

Termination side dimensions (T)		
Hole distance	Thickness	No. of holes
27	20	3

Frame size	Configuration	Width
Fr-2 N/S	400 - 2500A	Vertical / Horizontal
		100

All dimensions are in mm
For ordering cat nos please refer page no.80

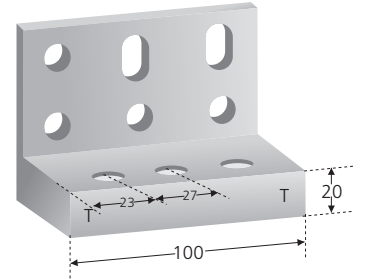
**Frame-2 : 3200 N & 400 - 4000A S/H**

Termination side dimensions (T)		
Hole distance	Thickness	No. of holes
27	20	3

Frame size	Configuration	Width
Fr-2 H/V	400 - 4000A	Vertical / Horizontal
		100

All dimensions are in mm
For ordering cat nos please refer page no.80

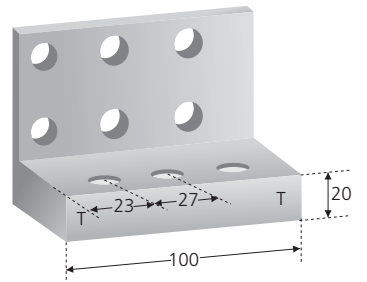
**Frame-3 : 5000A H/V**

Termination side dimensions (T)		
Hole distance	Thickness	No. of holes
27	20	2

Frame size	Configuration	Width
Fr-3 H/V	5000A	Vertical / Horizontal
		75



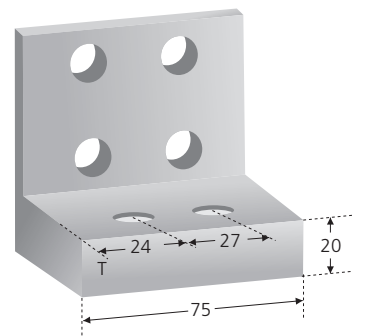



All dimensions are in mm | T: Termination side
For ordering cat nos please refer page no.80



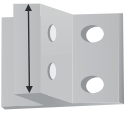

Following table consists of the total nos of the terminal adaptors required for each breaker (Top & Bottom side included)

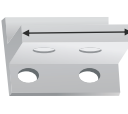
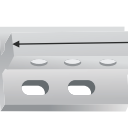
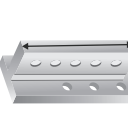
D/O	Rating	3P	4P	Orientation
Frame 1	400-2000A	6	8	any
	2500A	6	8	any
Frame 2	400-3200A	6	8	any
	4000A	6	8	Horizontal
Frame 3	4000A	6	8	Vertical
	4000-5000A	6	8	Horizontal
Fix	6300A	12	16	Vertical
	6300A	12	16	Vertical

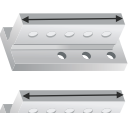
Draw Out Version

Fr	Frame 1		Frame 2		Frame 3	
	400A-2000A	2500A	400A-3200A	4000A	400A-4000A	5000A
Horizontal		Vertical termination recommended				
	Width : 65mm CL609630000	Vertical termination recommended	Width : 98mm CL609640000	Width : 100mm CL603160000	Width : 165mm CL600730000	Width : 165mm CL609660000
Vertical						
	Height : 65mm CL609630000	Height : 98mm CL609640000	Height : 150mm CL609650000	Height : 125mm CL601280000 (1EA)	Height : 125mm CL600670000 (1EA)	Height : 150mm CL609650000 (1EA)

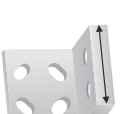
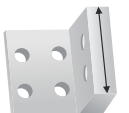
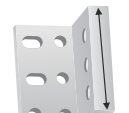
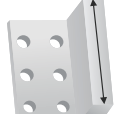
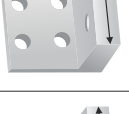
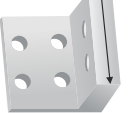
Fix Version

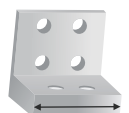
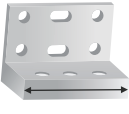
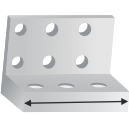
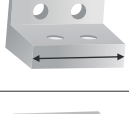
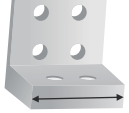
Fr	Frame 1		Frame 2		Frame 3	
	N/S	H	N/S	N*/S#/H	H/V	H/V
Horizontal						
	Width : 65 mm CL609670000	Width : 65 mm CL609680000	Width : 100 mm CL601220000	Width : 100 mm CL609770000	Width : 65 mm CL906680000 (1EA)	Width : 75 mm CL609820000 (1EA)
Vertical						
	Height : 65 mm CL609670000	Height : 65 mm CL609680000	Height : 100 mm CL609760000	Height : 100 mm CL609770000	Height : 65 mm CCL906680000 (1EA)	Height : 100 mm CL906690000 (1EA)

*For 3200A N Version
For 3200A & 4000A S Version

5) Neutral Configurator :

Neutral configurator helps in customization of Neutral Sequence or Phase Sequence at the Air Circuit Breaker end. Neutral Configurator can be connected with the breaker On-site. It enables user to customize the phase sequence at breaker end without any design modification required in panel. In case of standard phase sequence the output of the Breaker CTs directly connected to the MTX Release with the help of Wire harness. When Neutral Configurator is being used it will be connected to the MTX Release and harness wire will be connected to the other end of the Neutral Configurator. It can be used irrespective of Breaker frame sizes, Ratings and MTX Release types. Neutral configurator is compatible with 100%N systems only.

Note 1: While Neutral Configurator is being used for interchanging Neutral Pole with any other pole, the Cts of respective Poles must also be interchanged. Therefore CT of the old Neutral-Pole should now be placed in new Neutral Pole.

Note 2: For Releases MTX3.5/3.5EC/3.5H/4.5 Voltage Tapping Input at SIC Contacts V0 (N), V1 (R), V2 (Y) & V3 (B) should also be interchanged in accordance with used Neutral Configurator.

Available in configuration of-

- NRYB to RYBN
- NRYB to NBYR
- NRYB to BYRN

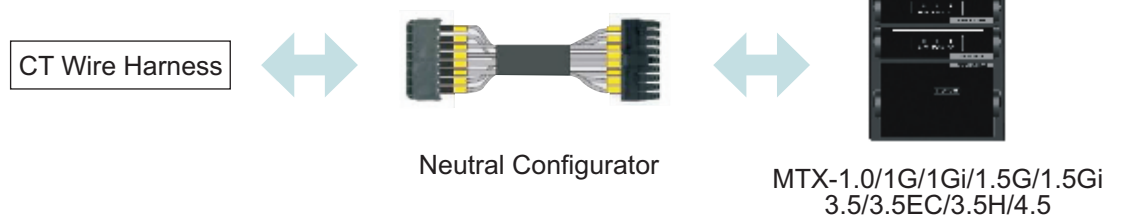

6) External Neutral CTs

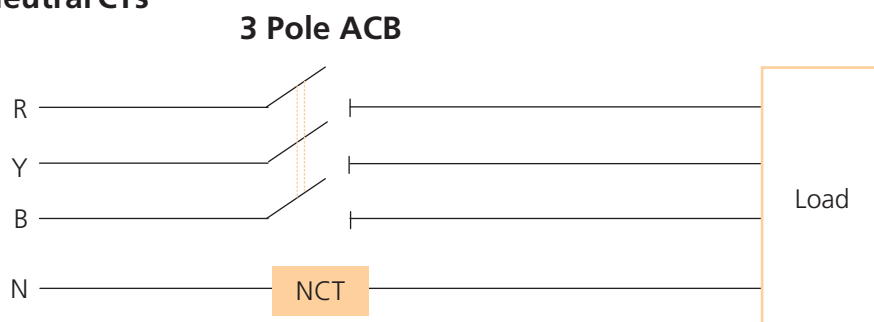

In case of TPN system, NCT must be used to avoid nuisance tripping of the three pole ACB under unbalanced load condition.

In case of current unbalance,

$$I_R + I_Y + I_B + I_N = 0, \text{ but}$$

$$I_R + I_Y + I_B \neq 0$$

In absence of NCT, the EF enabled Protection & Control Unit will follow the second equation resulting in false indication of EF, and will trip if it exceeds threshold value, causing undesirable interruptions in the Electrical system and deterioration of ACB life.

Installation of NCT can also be used for Neutral Overload Protection for sensing overcurrent flowing through the neutral conductor.

For Earth fault protection and protection of Neutral against overloads, Neutral CT is required. For 4-Pole breakers, the CT is provided inside the breaker, to be used on 4 wire system whereas for 3-pole breakers, external CT is available separately.

It is important that with OMEGA System of breaker, special neutral CTs supplied by E&A are used.

Frame Size	Rating
1, 2 & 3	400/630/800/
1, 2 & 3	1000/1250/1600

(ref. Page 14 for Frame size details)
TERMINAL THICKNESS 15 mm.

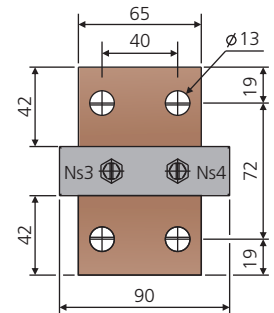
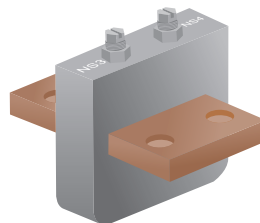

Frame Size	Rating
1	2000/2500

(ref. Page 14 for Frame size details)
TERMINAL THICKNESS 30 mm.

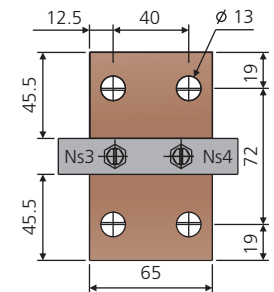
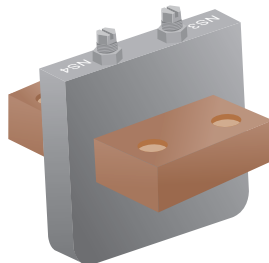

Frame Size	Rating
2 & 3	2000/2500/ 3200/4000

(ref. Page 14 for Frame size details)
TERMINAL THICKNESS 30 mm.

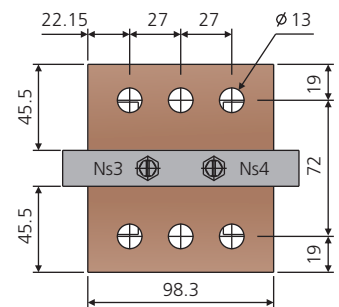
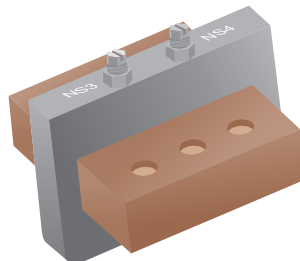

Frame Size	Rating
3	5000/6300

(ref. Page 14 for Frame size details)
TERMINAL THICKNESS 30 mm.

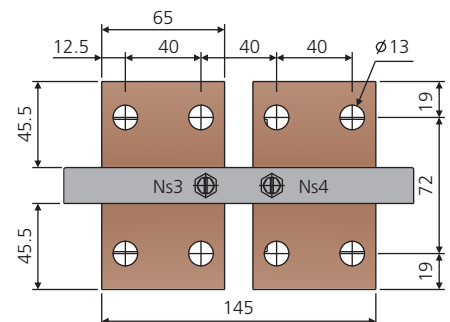
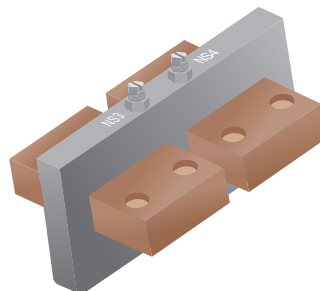

M12 / Equivalent bolts to be used for links termination.
Tightening torque: 3.2 kgfm
All Dimensions in mm

Control Circuit Wiring



UW-MTX1.0/1G/1Gi/1.5G/1.5Gi/3.5/3.5EC/3.5H/4.5

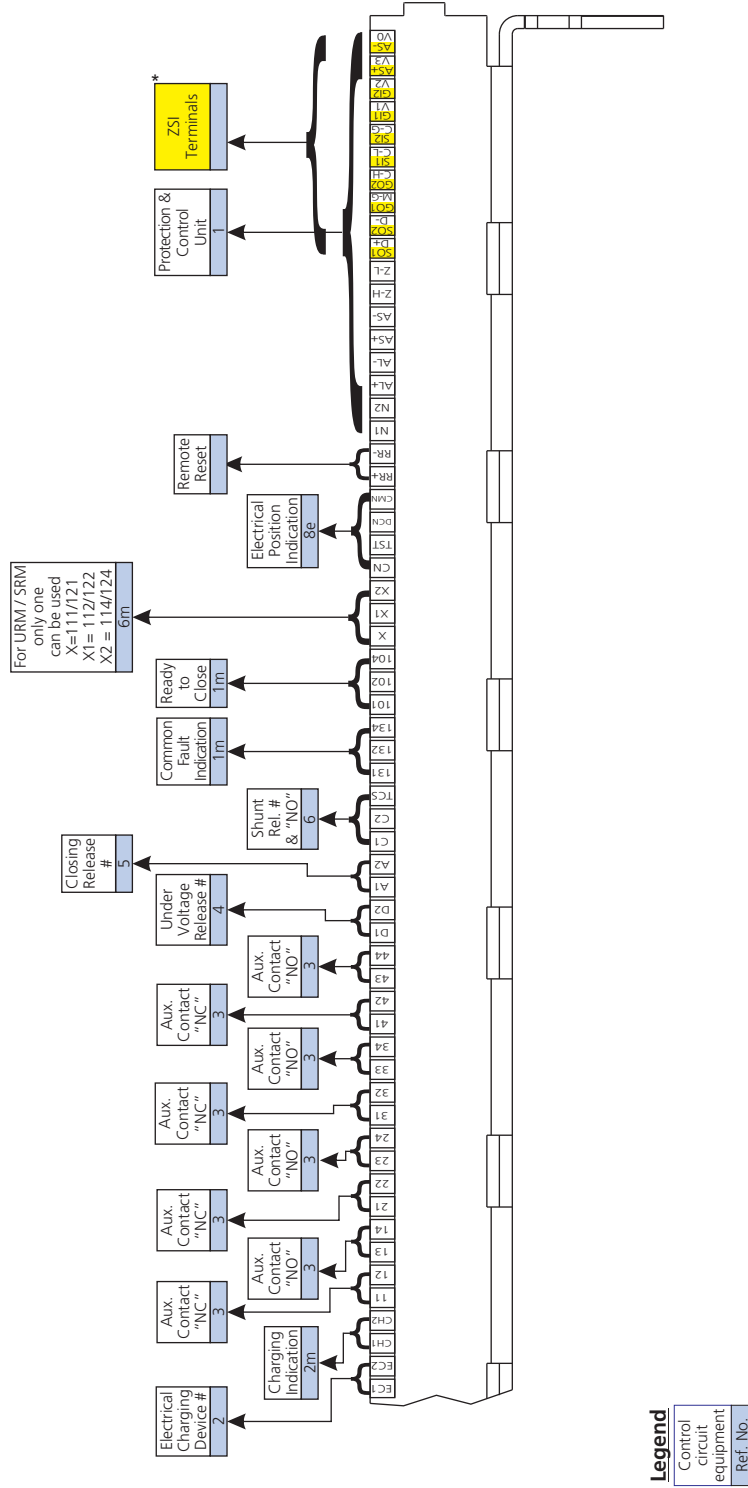

The above diagram gives a generic configuration for control termination on the breaker. For specific details, refer Connection diagram (pages 79 to 84) specific to the P&C unit installed in the breaker.

For using electrical accessories with DC Control Supply, it is recommended to connect D1/A1/C1 to +ve and D2/A2/C2 to -ve.

m indicates micro switch

* These ZSI Terminals should only be used for MTX 1 Gi/1.5Gi Releases.

Connection Details

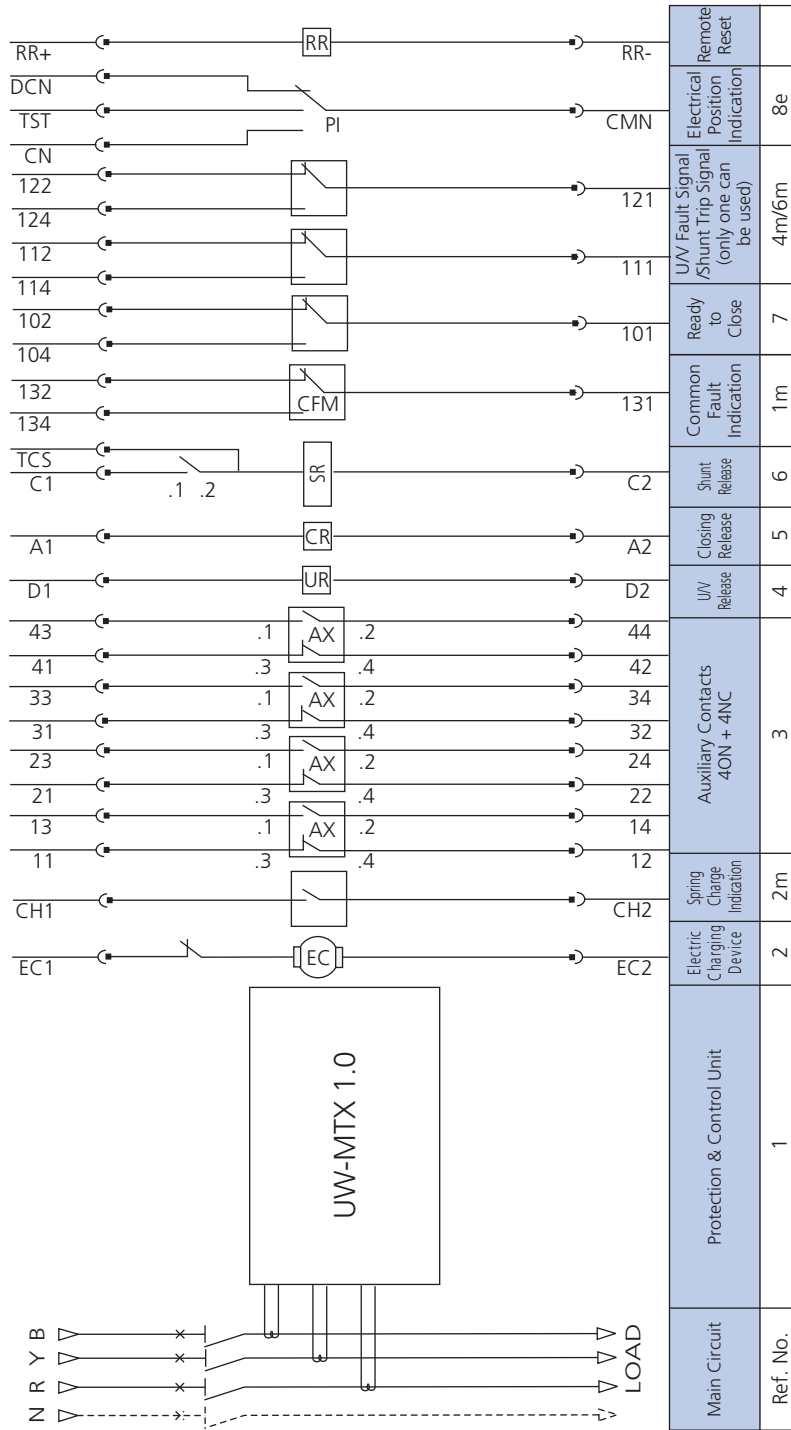

Connection Details

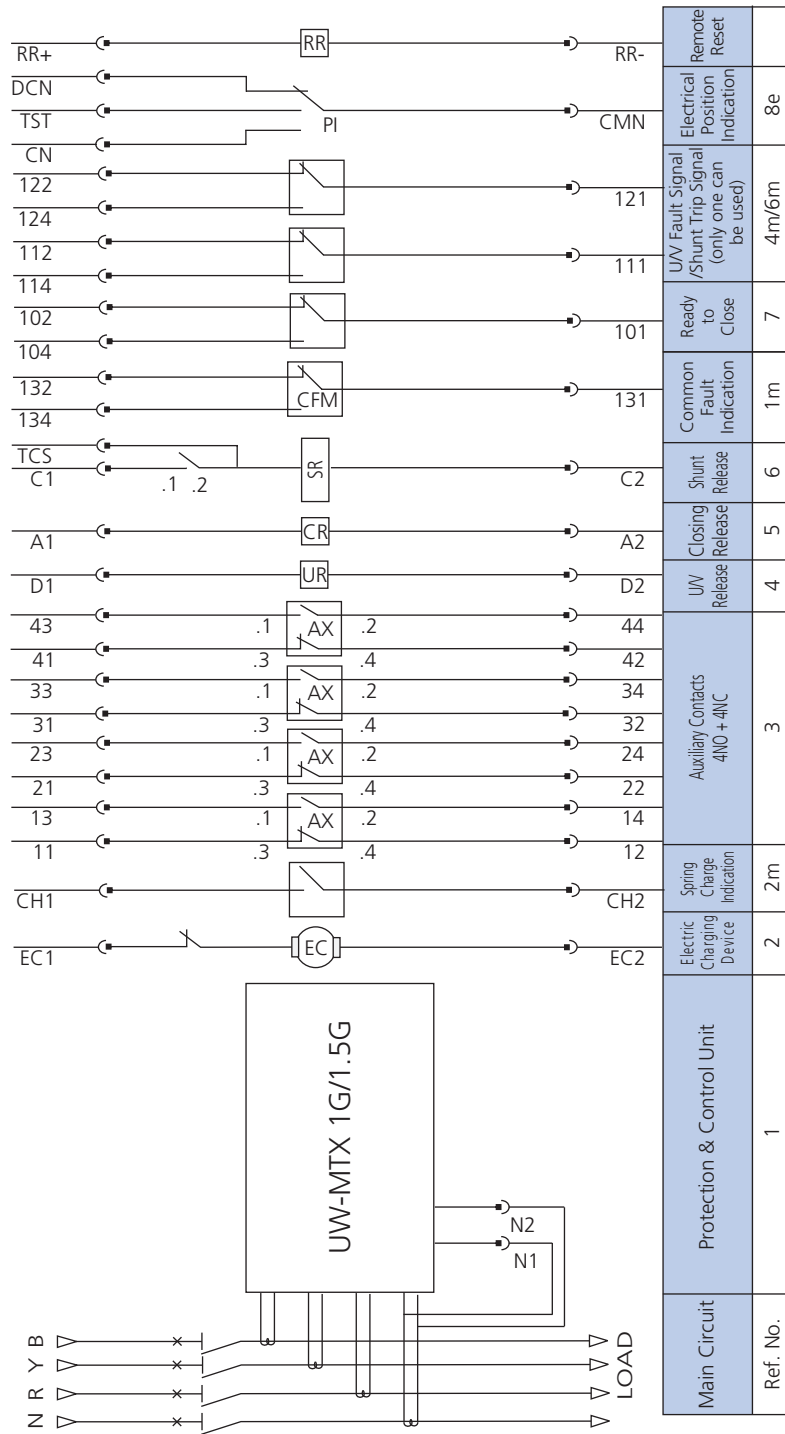

N1, N2: External Neutral CT

Connection Details

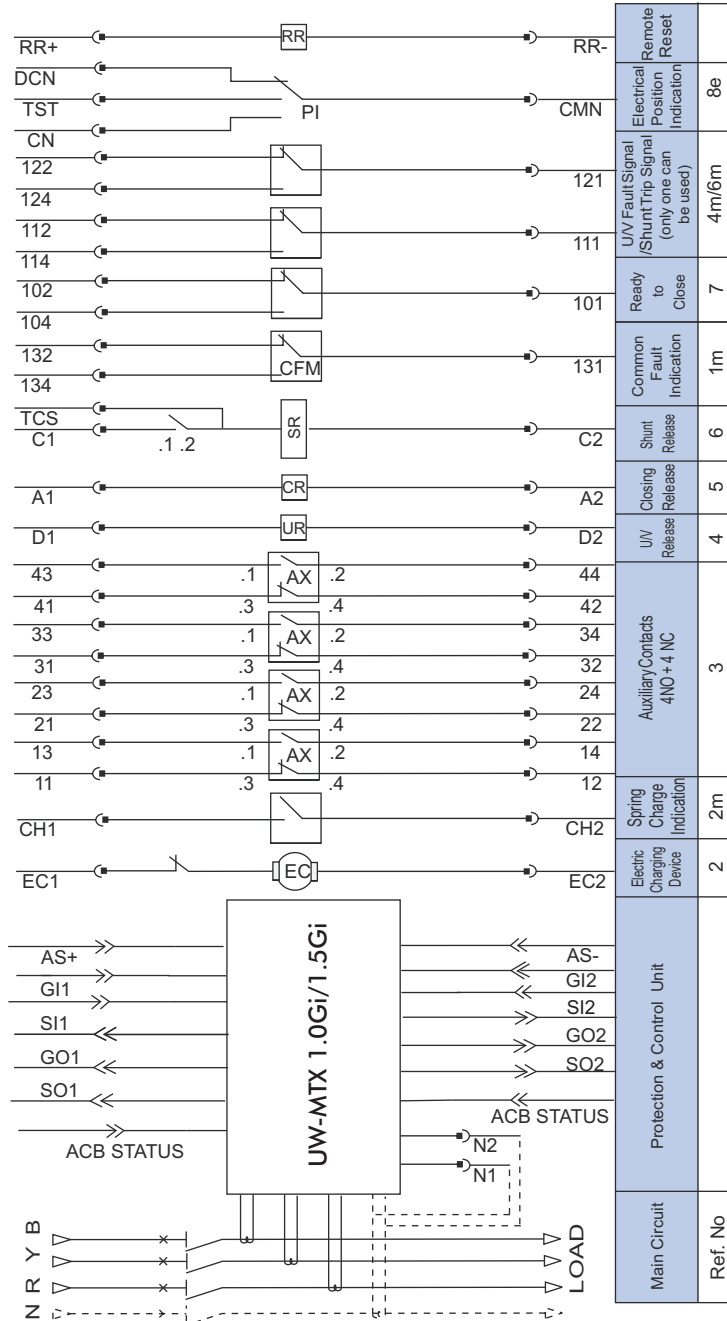

RR+	RR-	Remote Reset	
DCN	CMN	Electrical Position Indication	8e
TST			
CN	121	UV Fault Signal / Shunt Trip Signal (only one can be used)	4m/6m
122			
124			
112	111		
114			
102	101	Ready to Close	7
104			
132	131	Common Fault Indication	1m
134			
TCS	C2	Shunt Release	6
C1			
A1	A2	Closing Release	5
D1	D2	UV Release	4
43	44	Auxiliary Contacts 4NO + 4 NC	3
41	42		
33	34		
31	32		
23	24		
21	22		
13	14		
11	12		
CH1	CH2	Spring Charge Indication	2m
EC1	EC2	Electric Charging Device	2
		Protection & Control Unit	
		Main Circuit	
		Ref. No	

- AS+ : Auxiliary 24V DC
- AS- : Ground
- SO UT : ZSI S/C Output
- SIN : ZSI S/C Input
- GO UT : ZSI E/F Output
- GIN : ZSI E/F Input
- N1 : External Neutral CT
- N2 : External Neutral CT

Connection Details

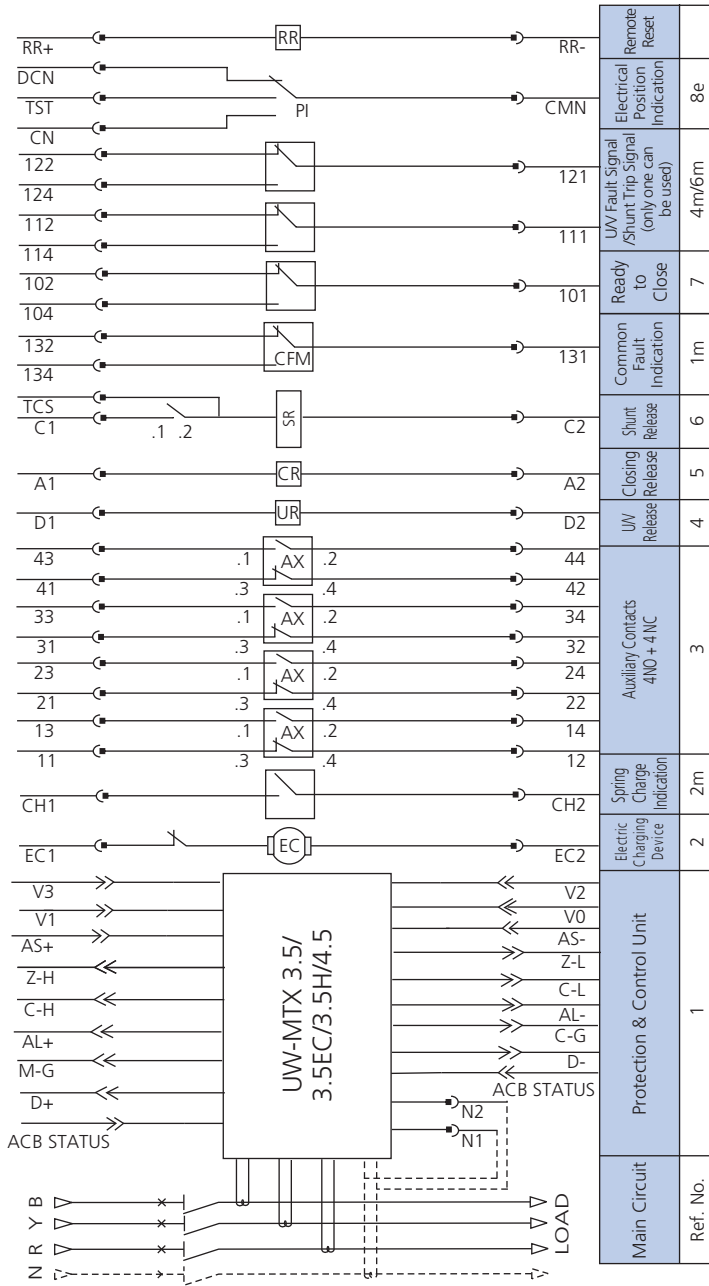

AS+, AS- : 24V DC Power Supply
 AL+, AL- : OL ALARM+, OL ALARM-
 This output can be connected to 5V-30V dc 150mA relay or any indicating device for indication or Load shedding purpose.

C-L : CAN-Low
 C-H : CAN-High
 M-G : MOD-GND
 C-G : CAN-GND
 V0, V1, V2, V3 : N, R, Y, B, VOLTAGE I/P.

D+ : MOD A
 D- : MOD B
 N1 : External Neutral CT
 N2 : External Neutral CT
 Z-L : ZSI CAN-Low
 Z-H : ZSI CAN-High

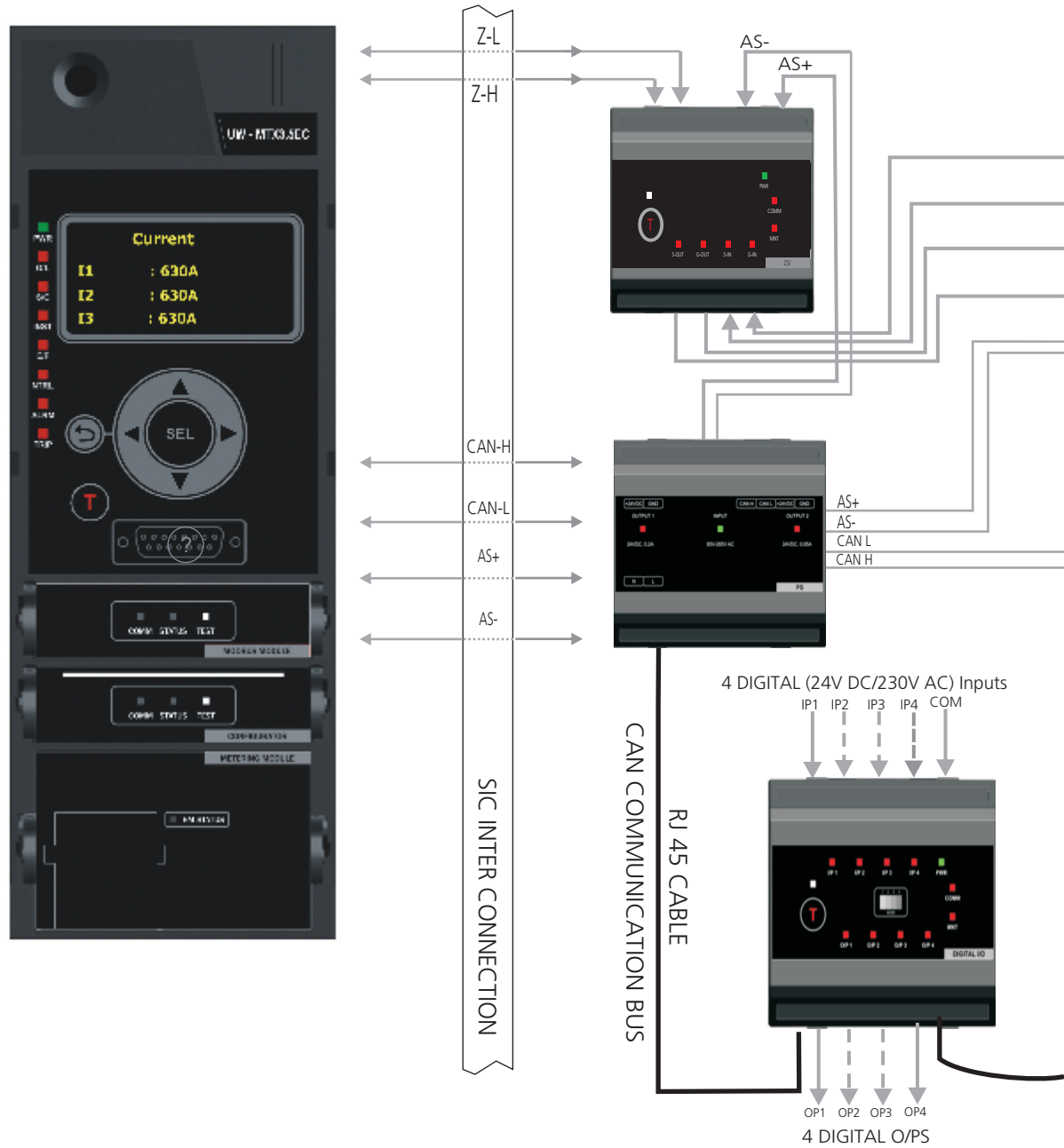

- AS+ : Auxiliary 24V DC
- AS- : Ground
- SOUT : S/C Output
- SIN : S/C Input
- GOUT : E/F Output
- GIN : E/F Input
- T1-T4 : Thermistor Inputs
- Z-L : ZSI CAN-Low
- Z-H : ZSI CAN-High
- CAN- H : CAN-High
- CAN- L : CAN-Low

Note: One Power Supply module can be connected to maximum 5 modules

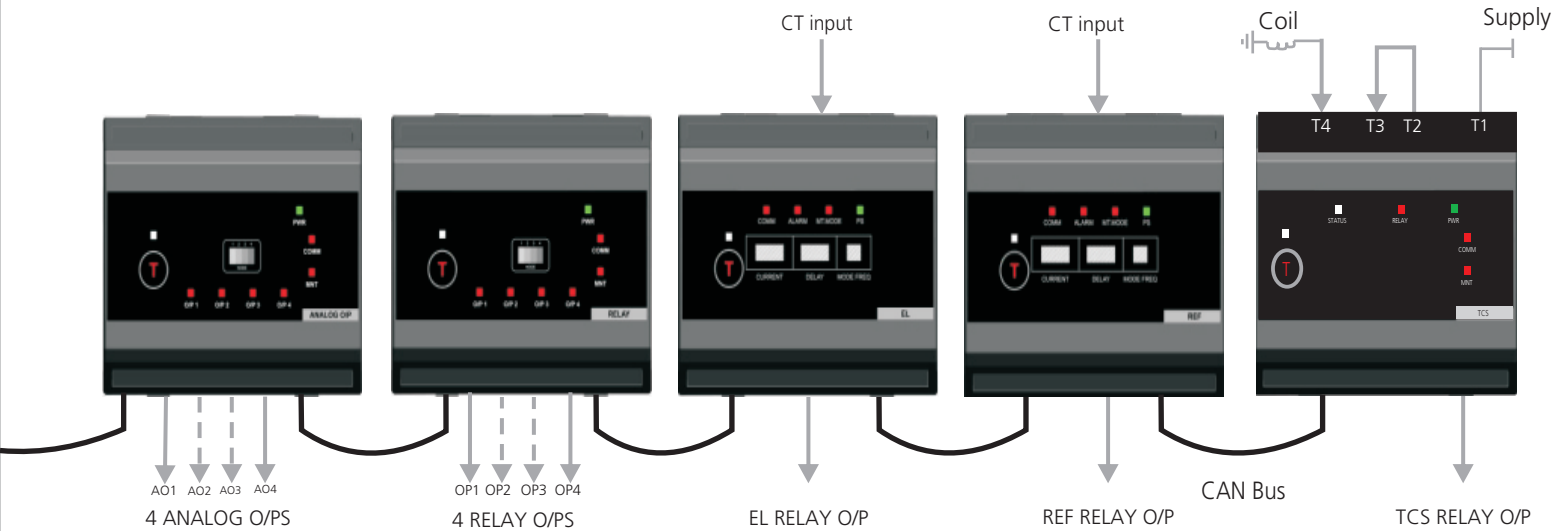
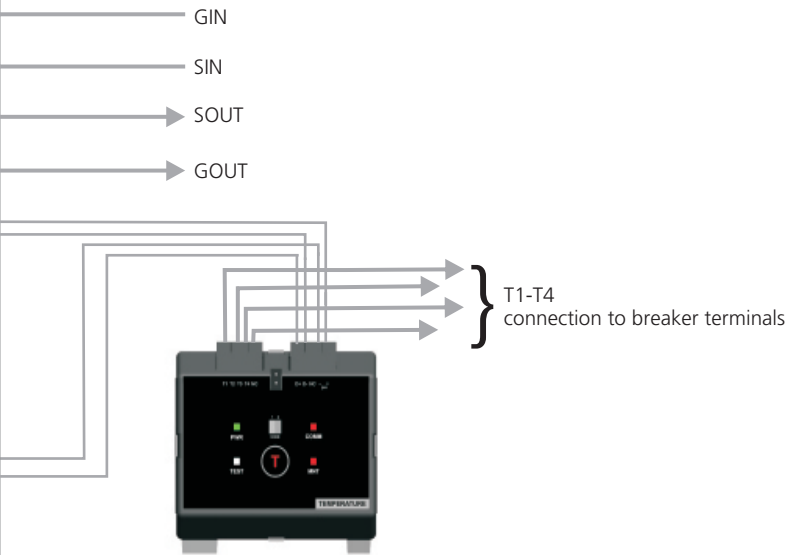



Mounting & Termination

Termination on Draw-out Breakers

OMEGA System of ACB terminals offer more contact area to accept Aluminium Links.

OMEGA System of ACBs Universal Flat terminals greatly facilitate termination. These terminals directly support all commonly used types of termination as shown in adjoining figure.

OMEGA System of ACB's are having inbuilt nutplates (M12 Threading) in Cradle terminal, to facilitate termination.

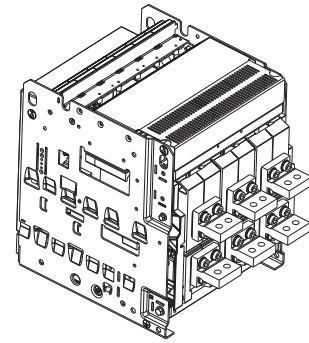
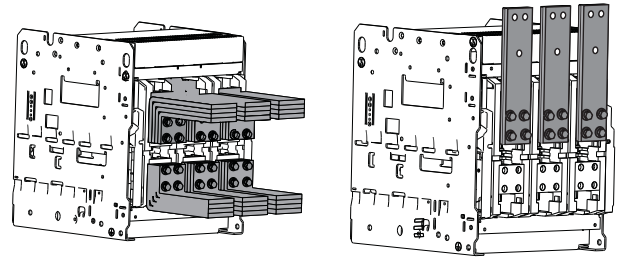

Terminal Adaptor

If required Terminal Adaptors are available as an accessory



Vertical/Horiz. Adaptors for Frame 1

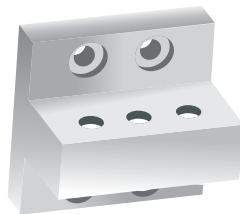

Vertical/Horiz. Adaptor for Frame 2

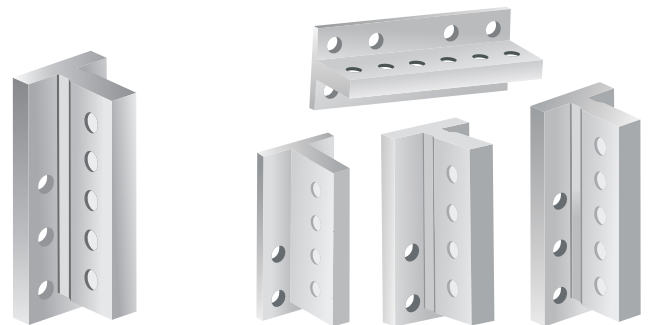

Vertical/Horiz. Adaptor for Frame 3

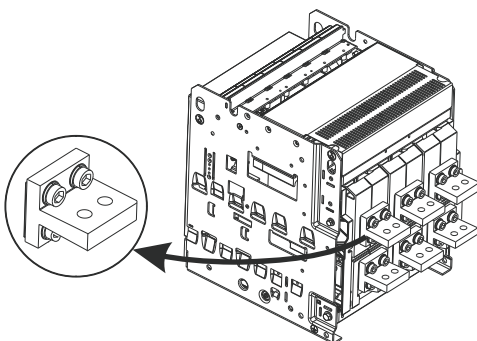

Installation of Terminal Adapter for frame 1

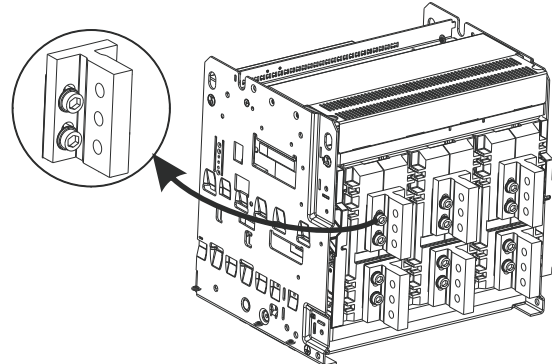

Installation of Terminal Adapter for frame 2

Terminal Adaptors supplied with Breakers Upto 1600A - Bottom only
Rest Breakers - Top & Bottom both

Termination Methods For Fixed Breakers

CAUTION:
Inadequate termination support may result in
overheating & adversely affect performance
during short circuit conditions.

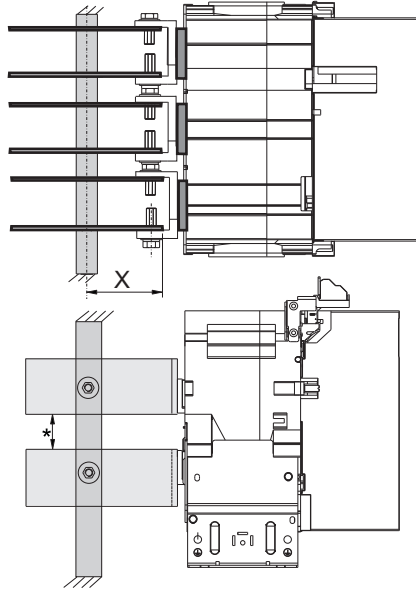

X = 100 -150 mm

For Draw-out Breakers

With Universal Terminals

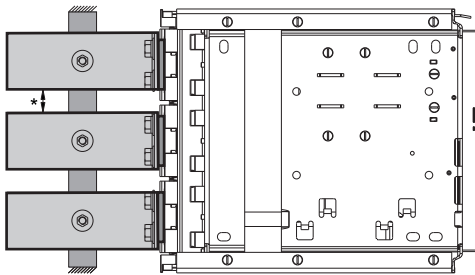

With Terminal Adaptor

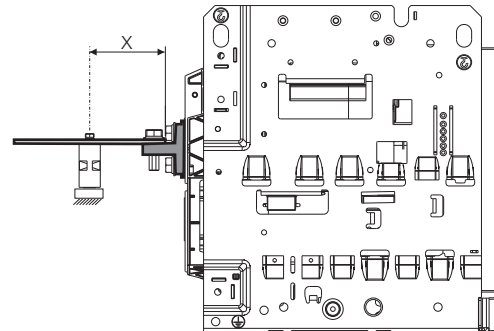
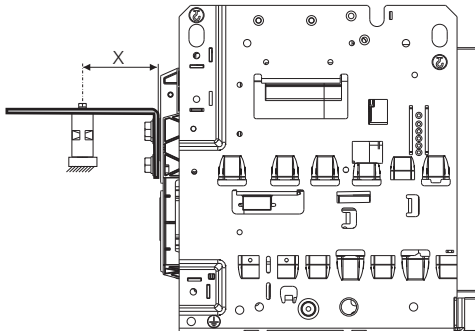
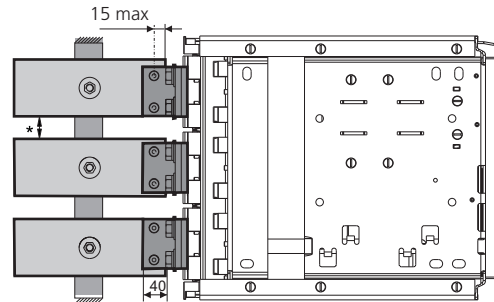

X = 100 -150 mm

* Maintain adequate clearance between links as applicable standards

All Dimensions in mm

400-1600A N & 400-2500A S/H Fr.1 3P Fixed Circuit Breaker

Frame 1	A
400-2000 N/S	326
2500 S	324
400-2500 H	324

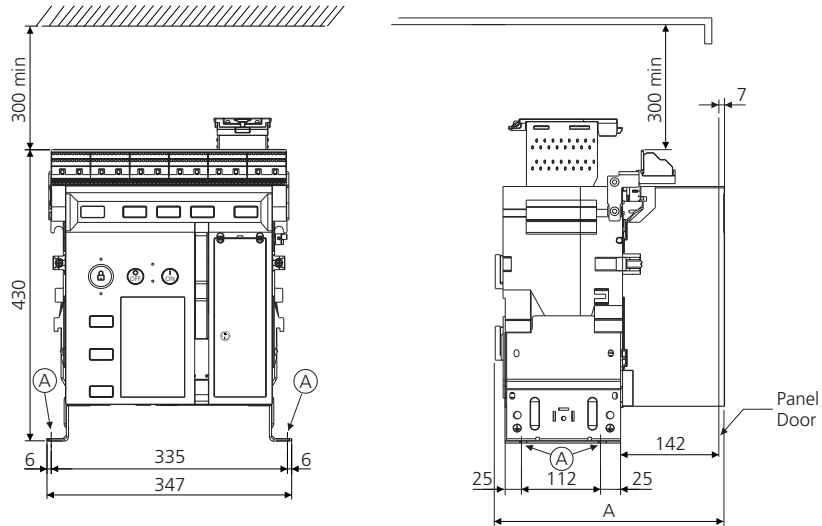

Draw-out Circuit Breaker

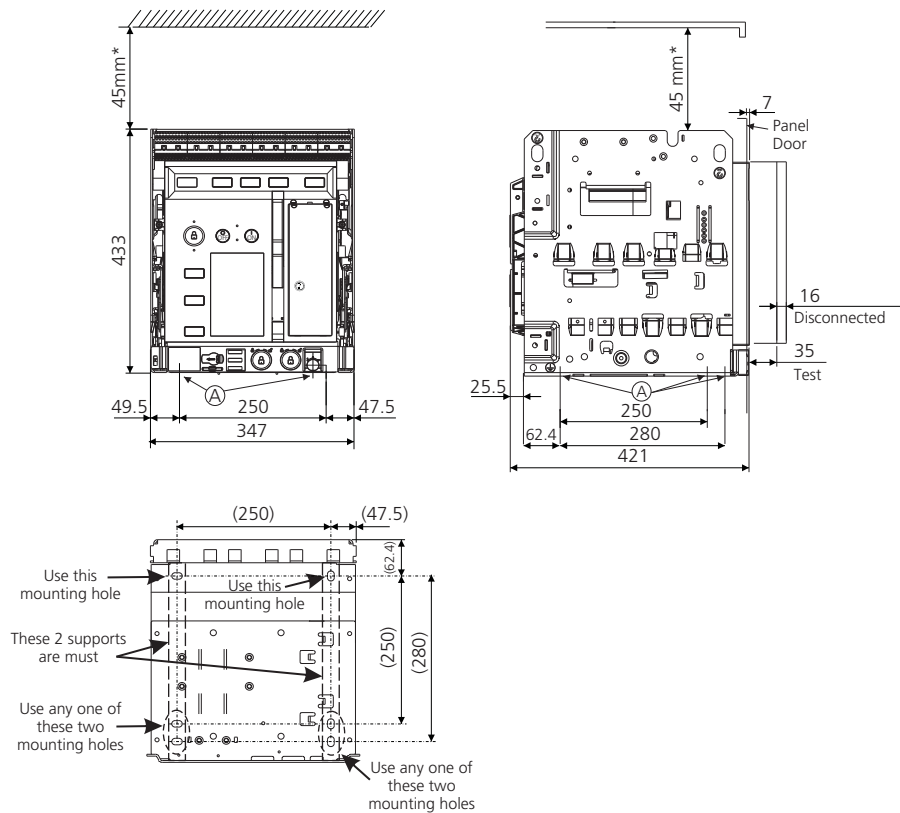

All Dimensions in mm

Ⓐ Mounting holes suitable for M10 / Equivalent BS bolt

* In case of Temperature Module mounted on the Cradle this dimension should be 70mm.

All Dimensions in mm

400-1600A N & 400-2500A S/H Fr.1 4P (100% N)

Fixed Circuit Breaker

Frame 1	A
400-2000 N/S	326
2500 S	324
400-2500 H	324

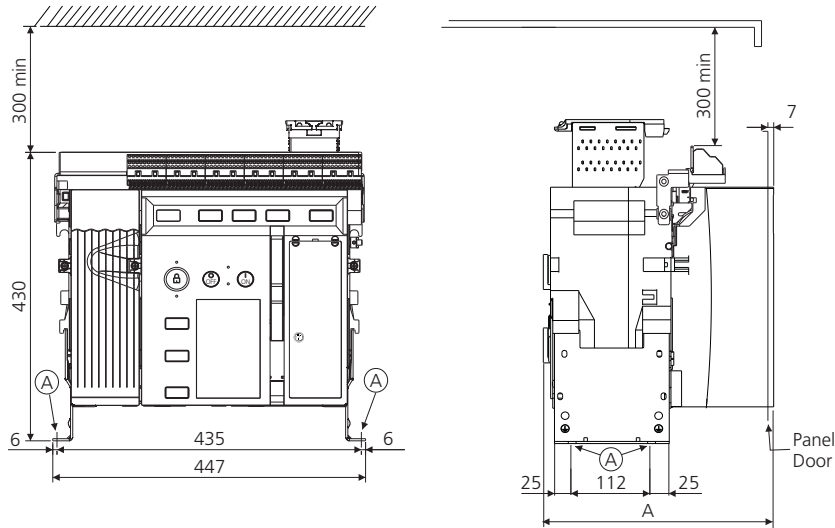

Draw-out Circuit Breaker

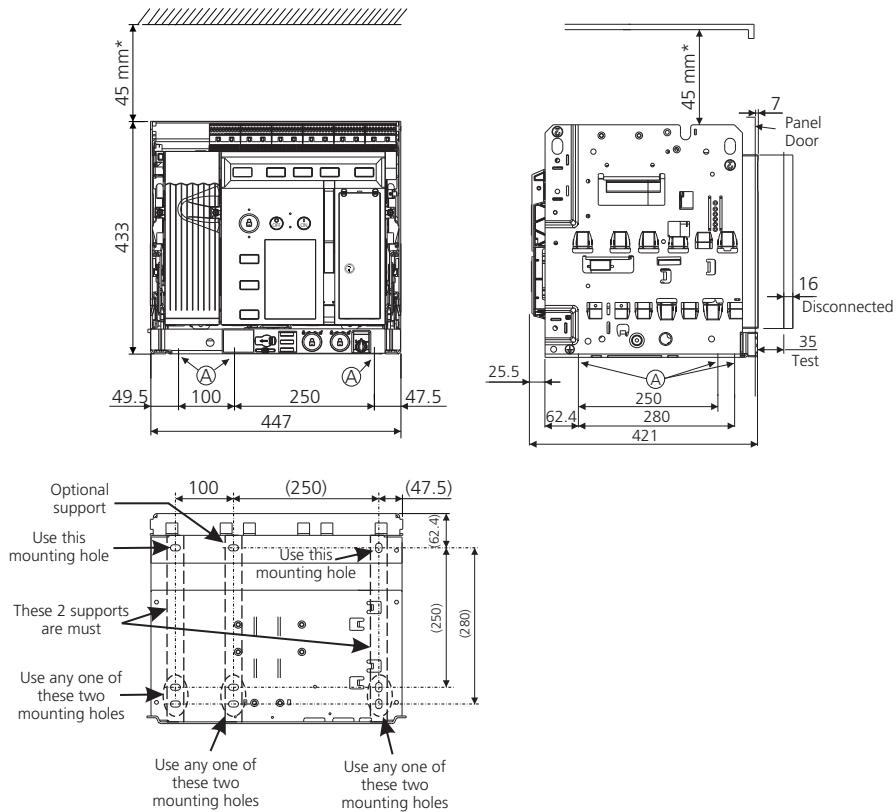

Details of 4P (200%) on request

All Dimensions in mm

(A) Mounting holes suitable for M10 / Equivalent BS bolt

* In case of Temperature Module mounted on the Cradle this dimension should be 70mm.

All Dimensions in mm

400-3200A N & 400-4000A S/H Fr.2 3P Fixed Circuit Breaker

Frame 2	A
400-2500 N/S	326
3200 N/S	324
400-3200 H	324
4000 S/H	324

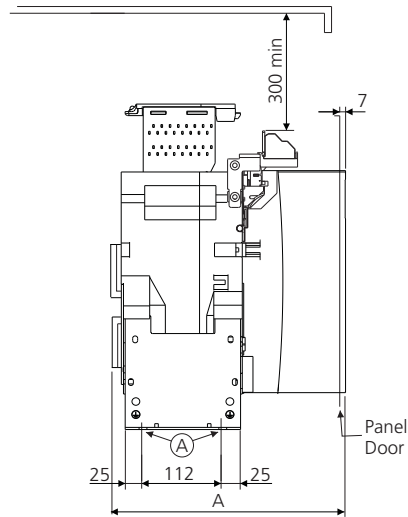
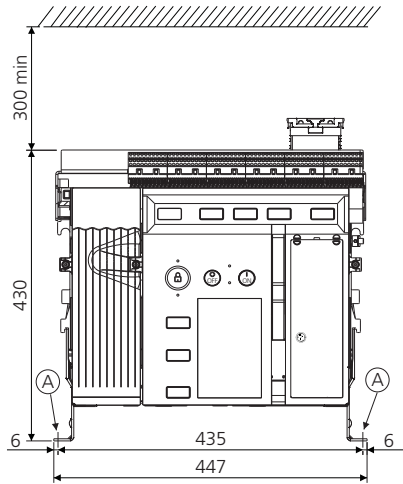

Draw-out Circuit Breaker

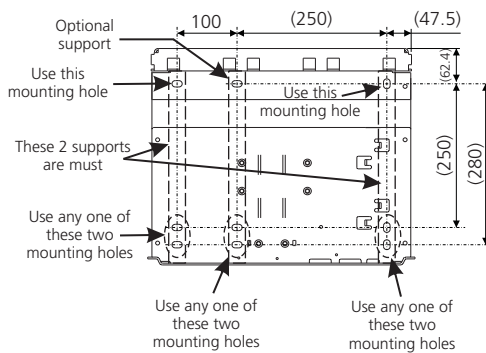
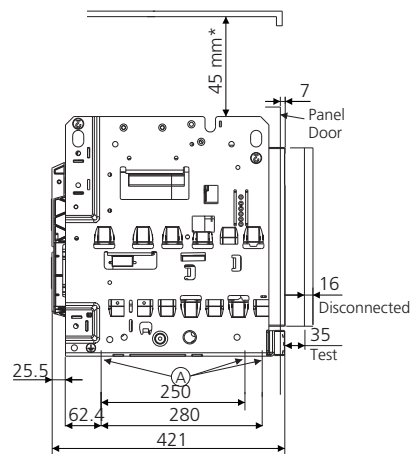
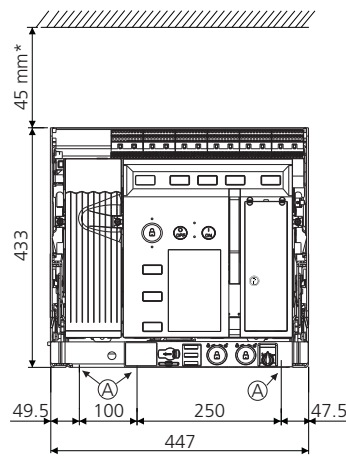

All Dimensions in mm

Ⓐ Mounting holes suitable for M10 / Equivalent BS bolt

* In case of Temperature Module mounted on the Cradle this dimension should be 70mm.

All Dimensions in mm

400-3200A N & 400-4000A S/H Fr.2 4P (100% N)

Fixed Circuit Breaker

Frame 2	A
400-2500 N/S	326
3200 N/S	324
400-3200 H	324
4000 S/H	324

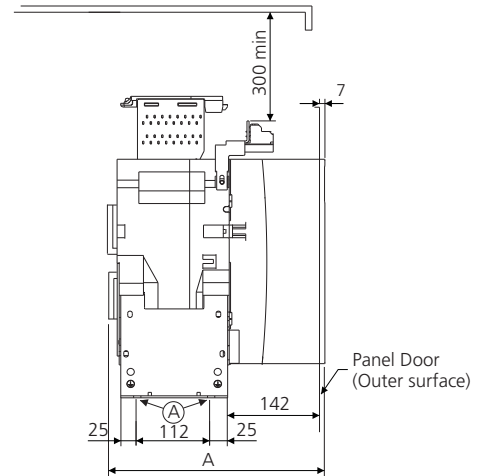
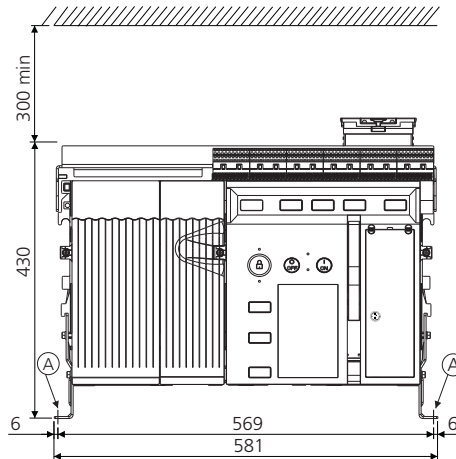

Draw-out Circuit Breaker

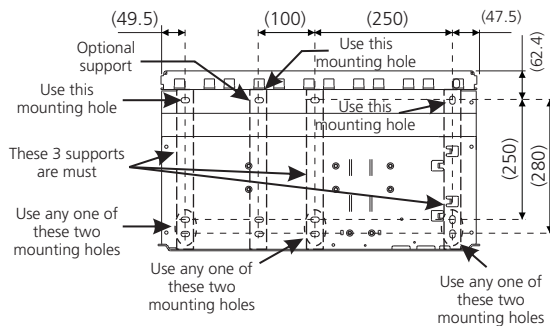
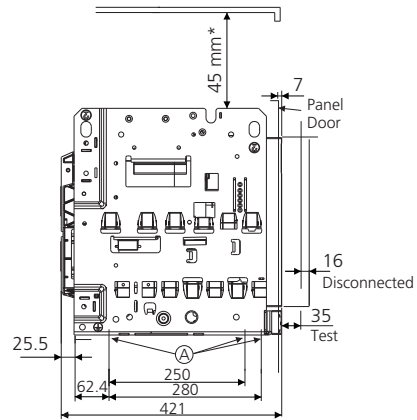
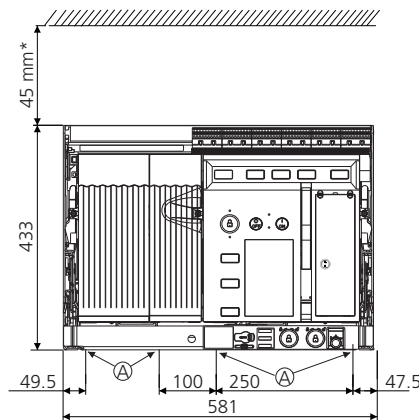

Details of 4P (200% N) on request

All Dimensions in mm

Ⓐ Mounting holes suitable for M10 / Equivalent BS bolt

* In case of Temperature Module mounted on the Cradle this dimension should be 70mm.

All Dimensions in mm

400-6300A H/V Fr.3 3P Fixed Circuit Breaker

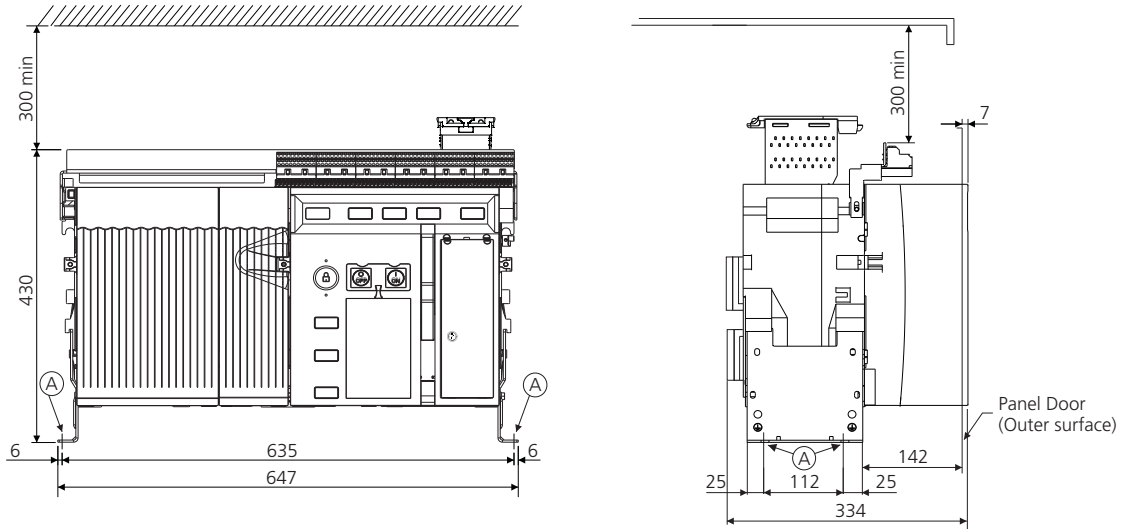

Draw-out Circuit Breaker

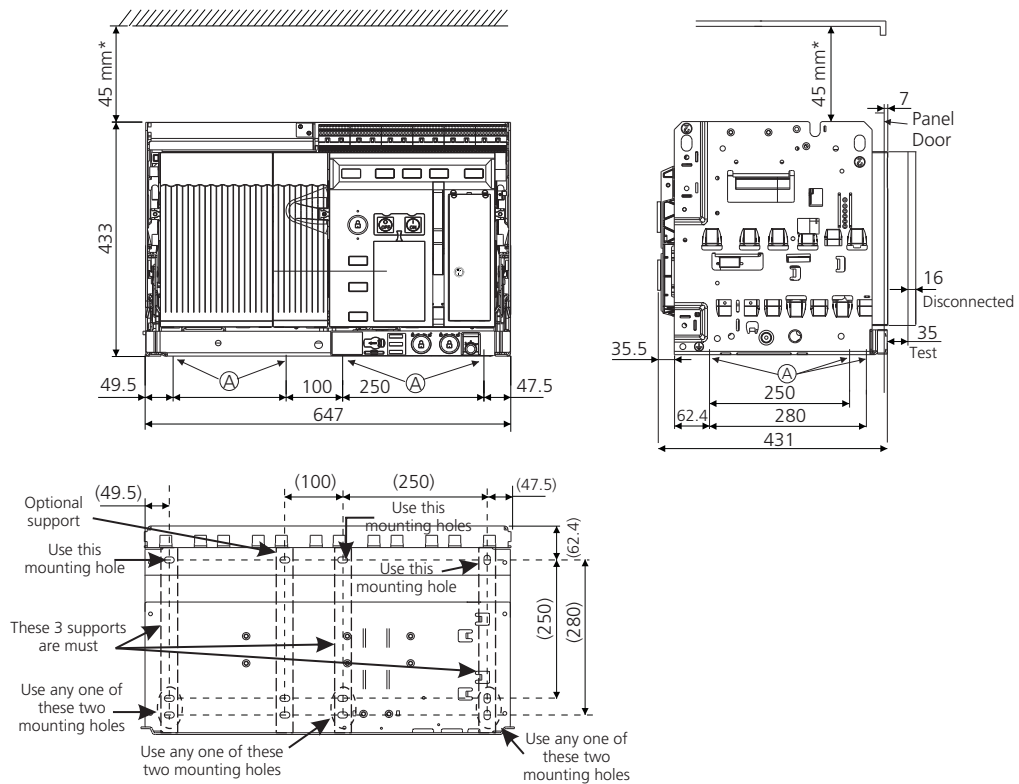

All Dimensions in mm

Ⓐ Mounting holes suitable for M10 / Equivalent BS bolt

* In case of Temperature Module mounted on the Cradle this dimension should be 70mm.

All Dimensions in mm

400-6300A H/V Fr.3 4P (100% N)

Fixed Circuit Breaker

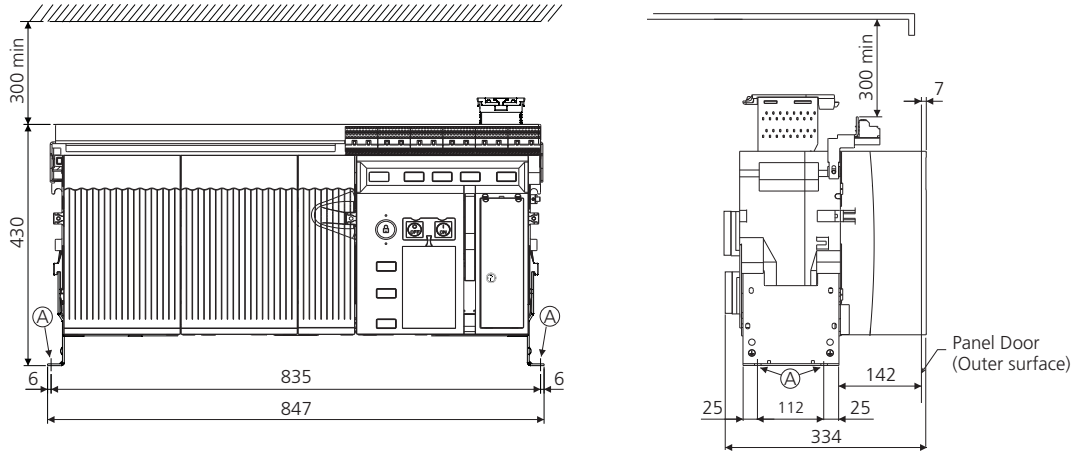

Draw-out Circuit Breaker

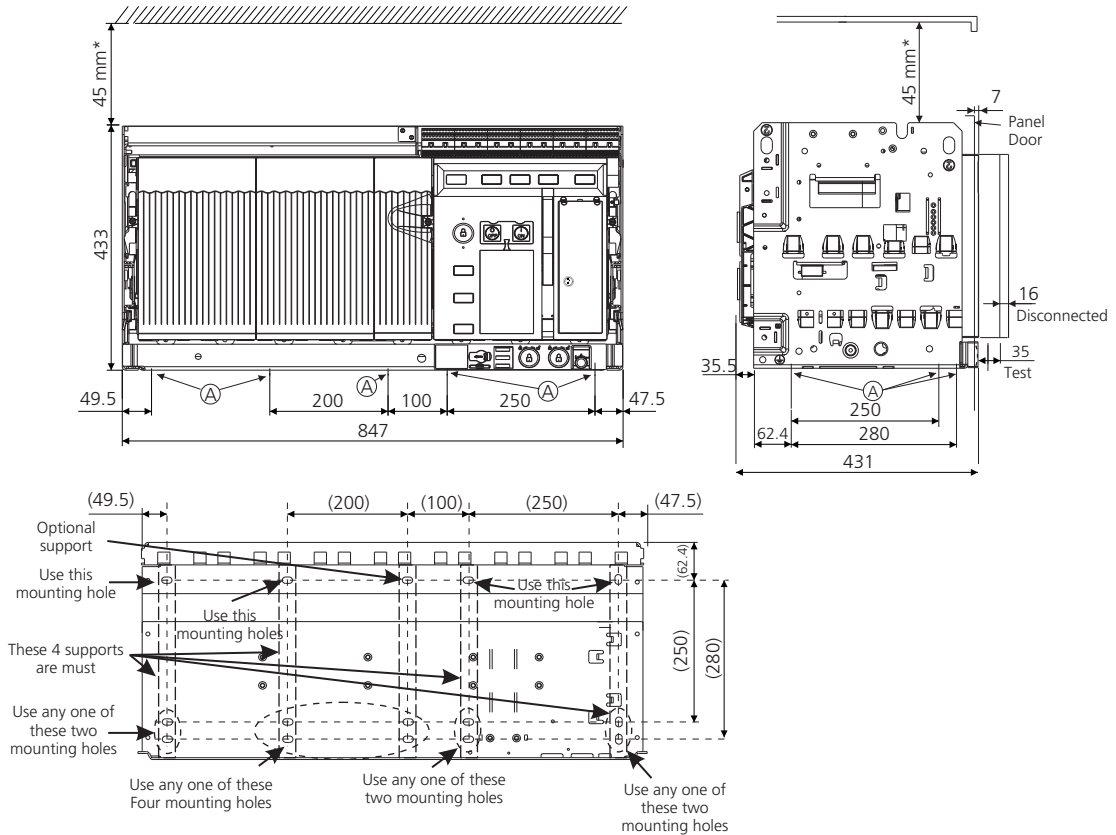

Details of 4P (50% N) on request

All Dimensions in mm

Ⓐ Mounting holes suitable for M10 / Equivalent BS bolt

* In case of Temperature Module mounted on the Cradle this dimension should be 70mm.

All Dimensions in mm

Flat Termination

400-1600N/S, 2000A N/S & 400-2000A H Fr.1-3P

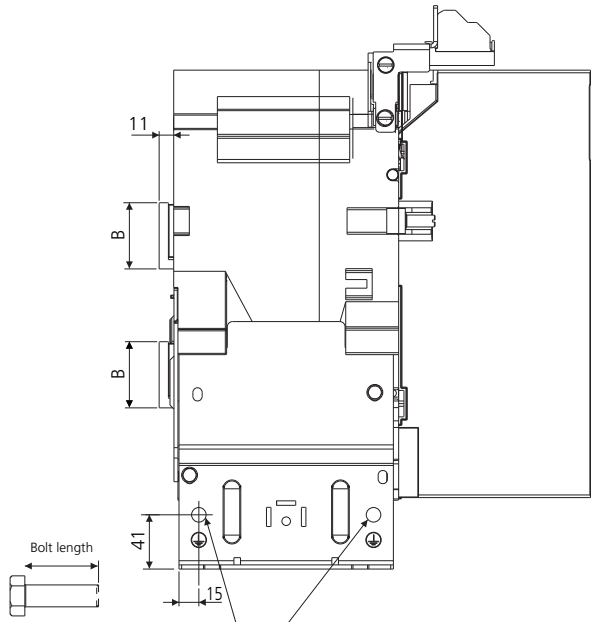

Bolt length for mounting link(s) on Flat Terminals to be cumulative link(s) thickness + 15 mm.

Holes (on both sides) for Earthing connections by M10/Equivalent BS bolt

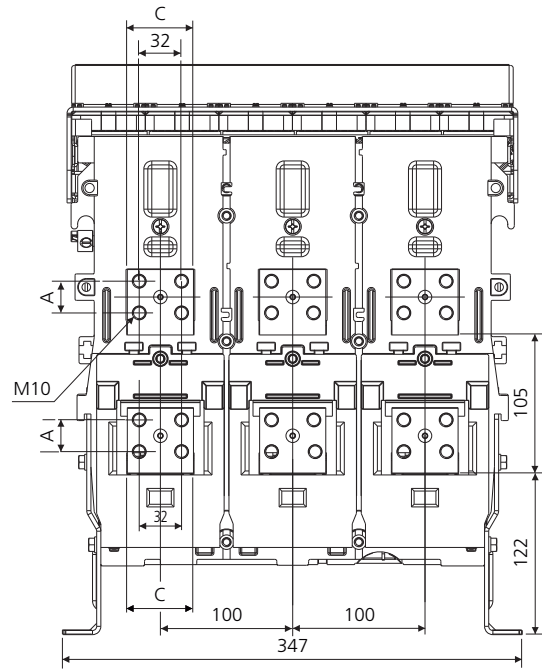

M10 bolts to be used for link termination
Tightening torque: 3.0 kgfm

Frame1	A	B	C
400-1600 N	24	50	50
400-1600 S	24	50	65
2000 N/S	24	50	65
400-2000 H	30	55	65

Horizontal Termination

400-2000 N/S/H Fr.1 3P

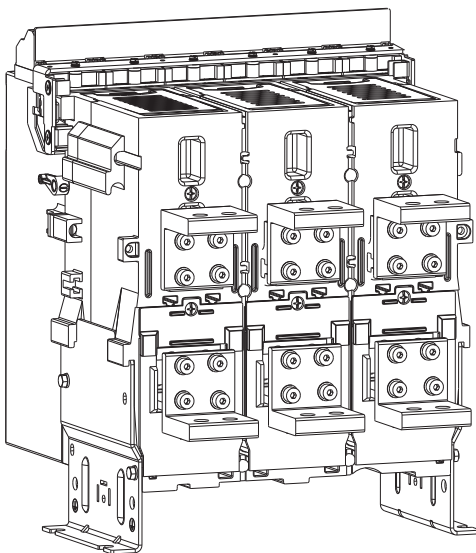

M12 / Equivalent BS bolts to be used for link termination
Tightening torque: 3.2 kgfm

Breaker Rating	Adaptor Cat. No.
400-2000 N/S	CL609670000
400-2000 H	CL609680000

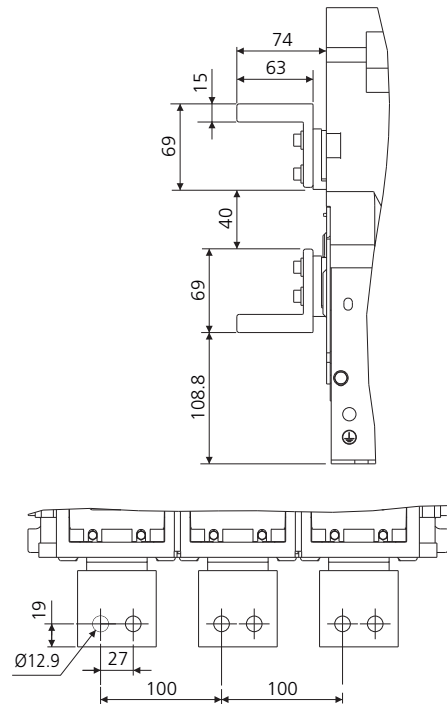

All Dimensions in mm

Vertical Terminals
400-2000A N/S/H

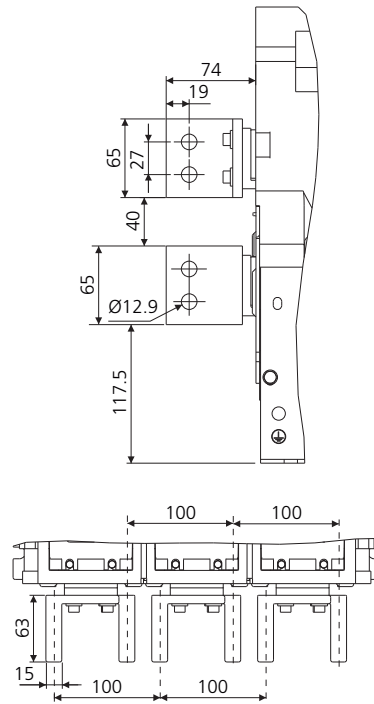
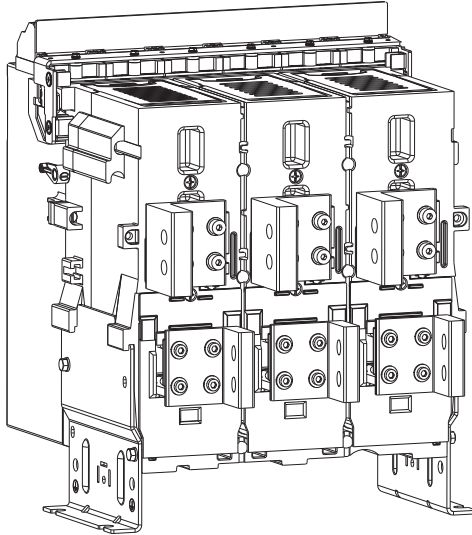

M12 / Equivalent BS bolts to be used for link termination
 Tightening torque: 3.2 kgfm

Breaker Rating	Adaptor Cat. No.
400-2000 N/S	CL609670000
400-2000 H	CL609680000

Vertical Terminals
2500A S/H Fr.1-3P (Adaptor-CL609760000)

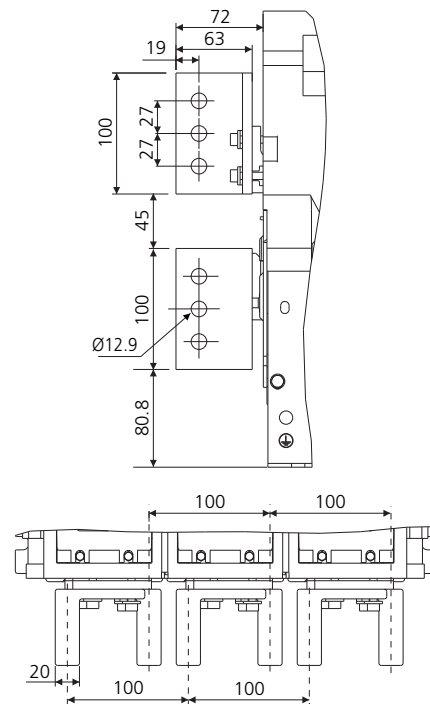
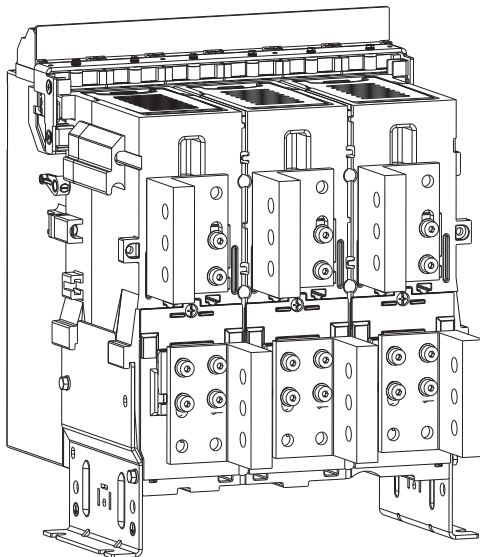

M12 /Equivalent BS bolts to be used for link termination
 Tightening torque: 3.2 kgfm

All Dimensions in mm

Flat Termination

400-1600 N/S, 2000A N/S & 400-2000A H Fr.1-4P

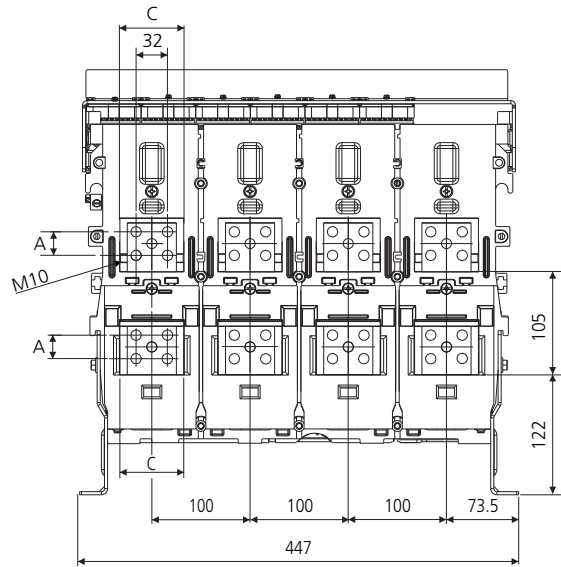
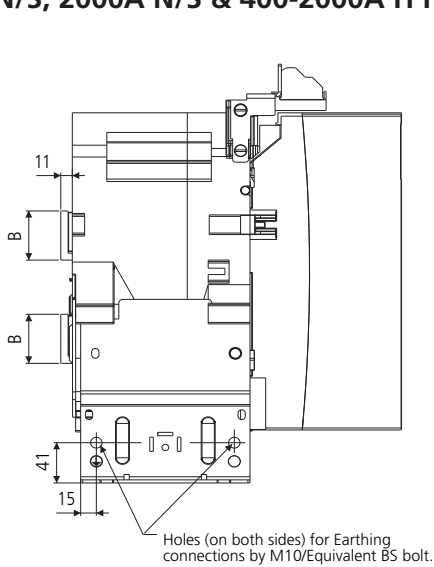

M10 bolts to be used for link termination
Tightening torque: 3.0 kgfm

 Bolt length
Bolt length for mounting link(s) on Flat Terminals to be cumulative link(s) thickness + 15 mm.

Frame1	A	B	C
400-1600 N	24	50	50
400-1600 S	24	50	65
2000 N/S	24	50	65
400-2000 H	30	55	65

Horizontal Termination

400a-2000A N/S/H Fr.1-4P

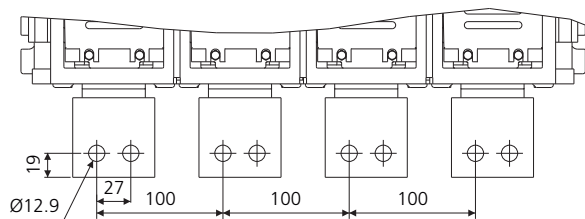
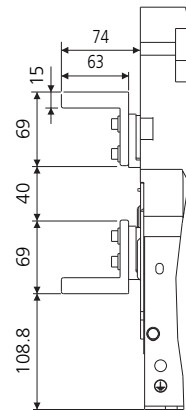
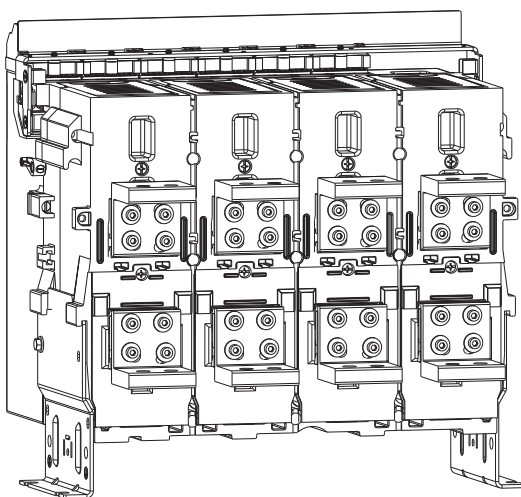

M12 / Equivalent BS bolts to be used for link termination
Tightening torque: 3.2 kgfm

Breaker Rating	Adaptor Cat. No.
400-2000 N/S	CL609670000
400-2000 H	CL609680000

All Dimensions in mm

Vertical Terminals

400-2000A N/S/H Fr.1-4P

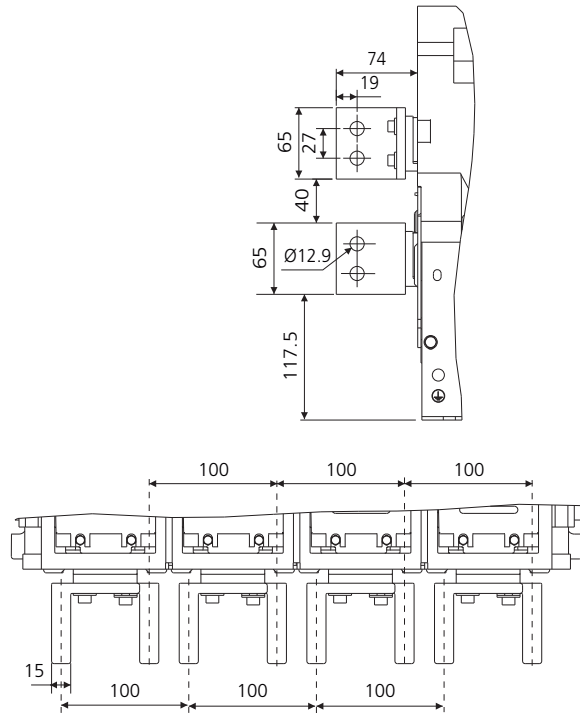
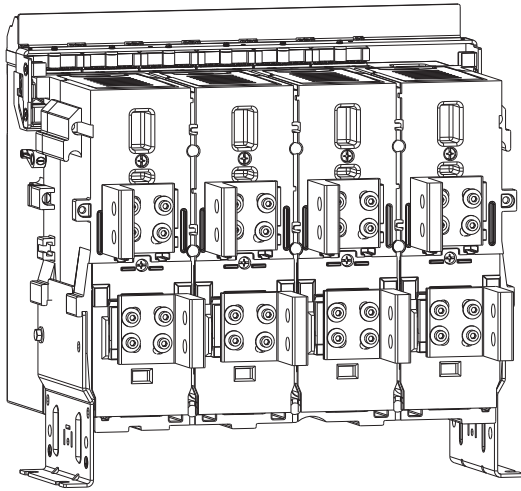

M12 / Equivalent BS bolts to be used for link termination
Tightening torque: 3.2 kgfm

Breaker Rating	Adaptor Cat. No.
400-2000 N/S	CL609670000
400-2000 H	CL609680000

Vertical Terminals

2500A S/H Fr.1-4P

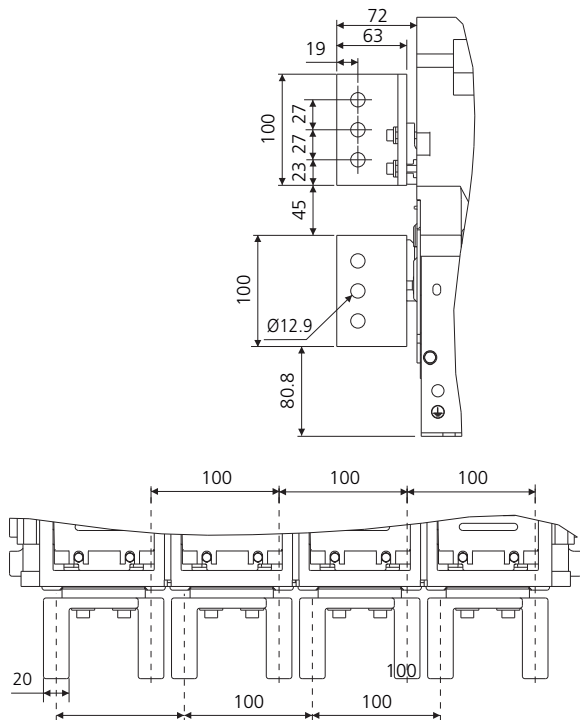
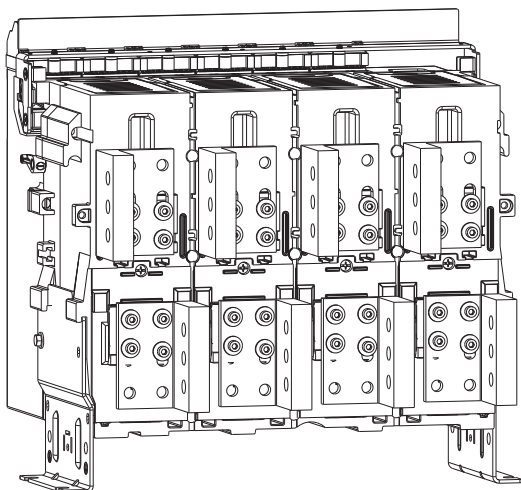

M12 / Equivalent BS bolts to be used for link termination
Tightening torque: 3.2 kgfm

All Dimensions in mm

Flat Termination

400-1600A N/S/H Fr.2 3P

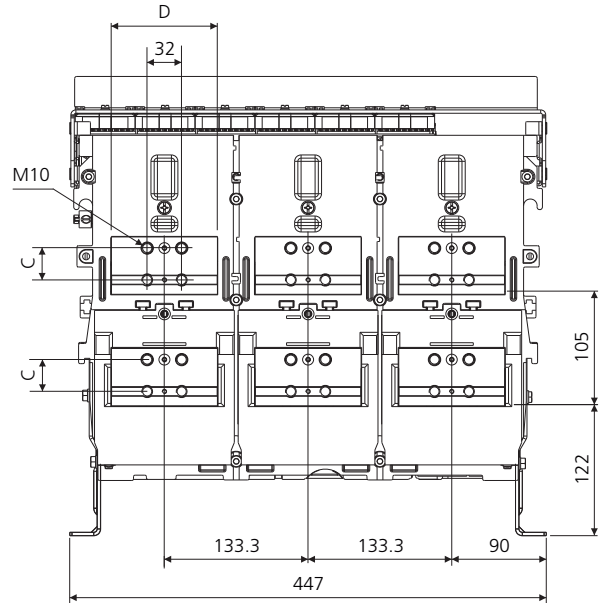
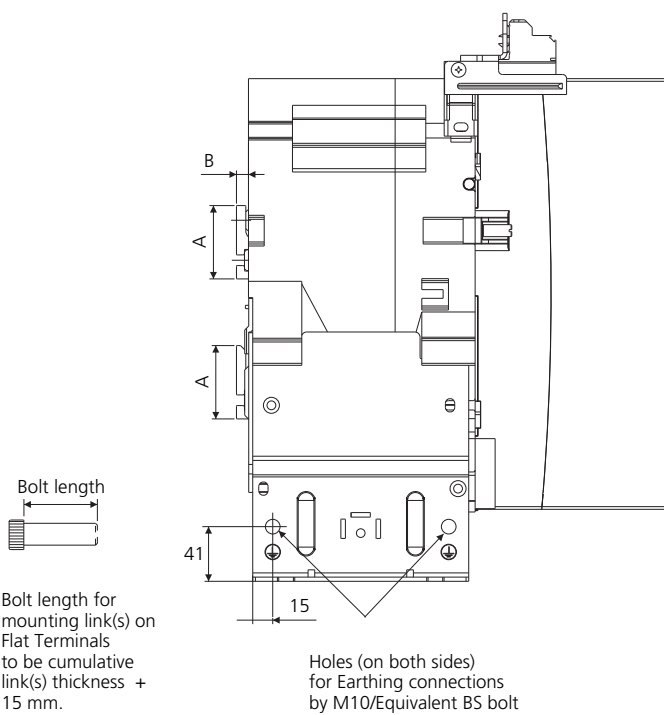

M10 / Equivalent BS bolts to be used for link termination.
Tightening torque: 3.2 kgfm

Frame1	A	B	C	D
400-1600 N/S	50	11	24	81.2
400-1600 H	55	9	30	98.4

Horizontal Termination

400-3200 N/S/H Fr.2 3P

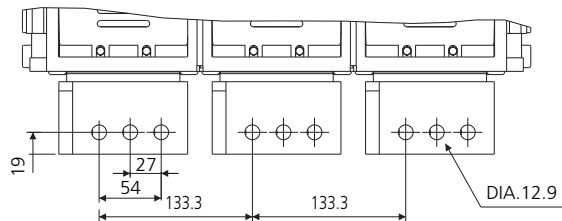
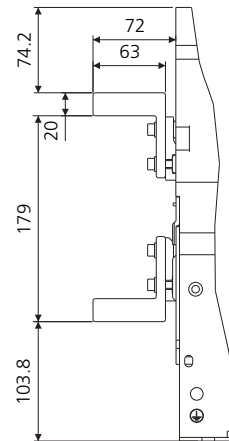
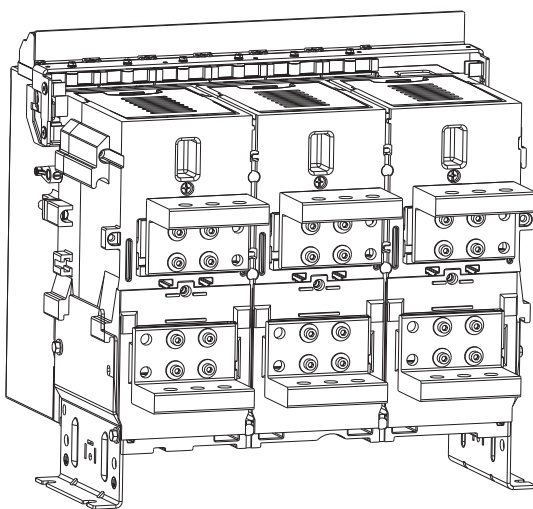

M12 / Equivalent BS bolts to be used for link termination.
Tightening torque: 3.2 kgfm

Details of 4P(200% N) on request.

All Dimensions in mm

Vertical Terminals

400-3200A N/S/H & 4000A S/H Fr.2-3P

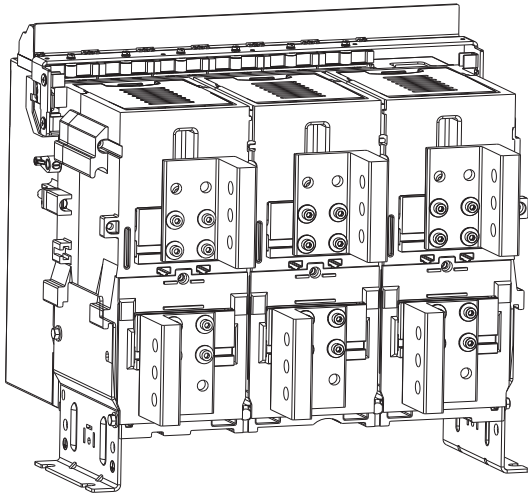

M12 / Equivalent BS bolts to be used for links termination.
Tightening torque: 3.2 kgfm

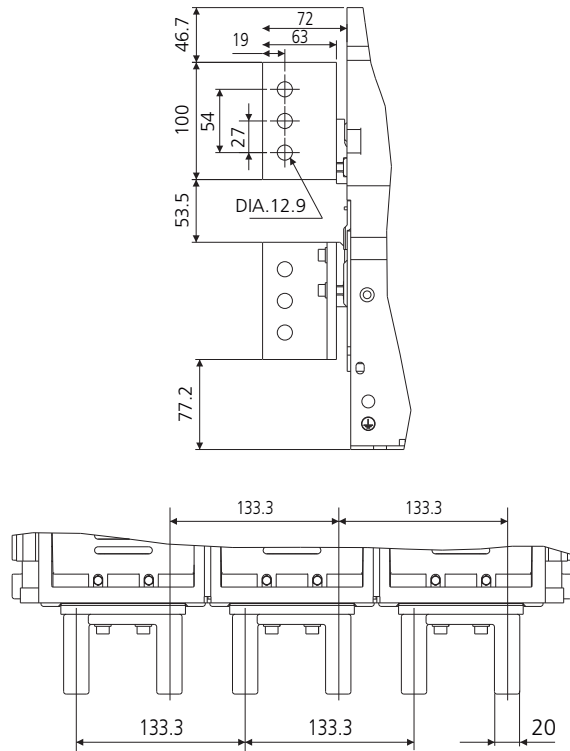

Top Horizontal & Bottom Vertical Termination

4000A S/H Fr.2-3P

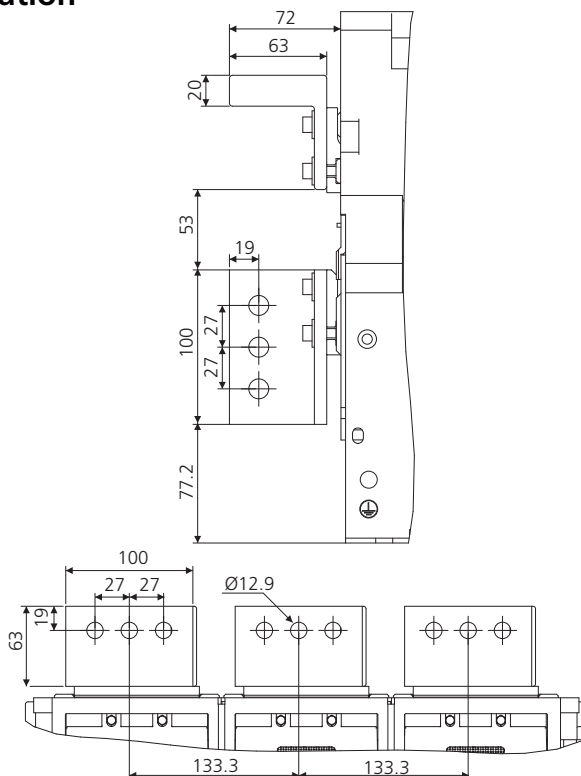
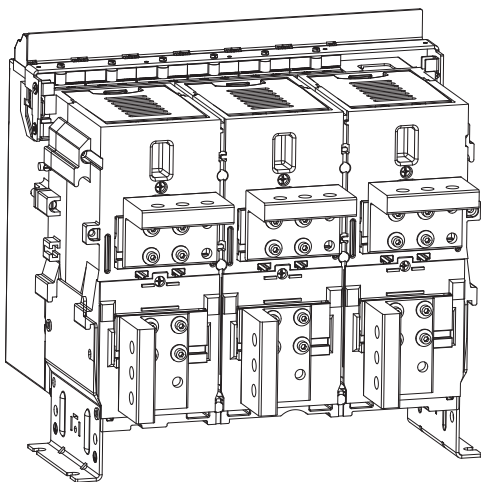

All Dimensions in mm

Flat Terminals

400-1600A N/S/H Fr.2-4P

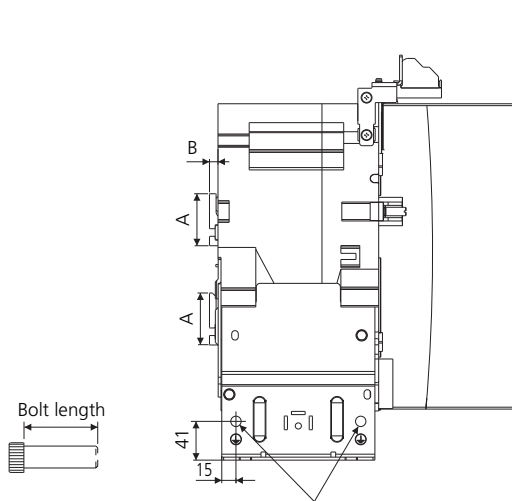

Bolt length for mounting link(s) on Flat Terminals to be cumulative link(s) thickness + 15 mm.

Holes (on both sides) for Earthing connections by M10/Equivalent BS bolt

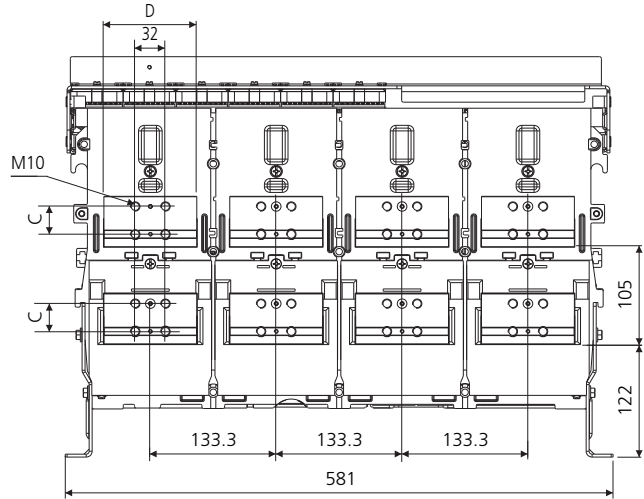

M10 / Equivalent BS bolts to be used for links termination. Tightening torque: 3.2 kgfm

Frame1	A	B	C	D
400-1600 N	50	11	24	81.2
400-1600 S	55	9	30	98.4

Horizontal Termination

400-3200A N/S/H Fr.2-4P

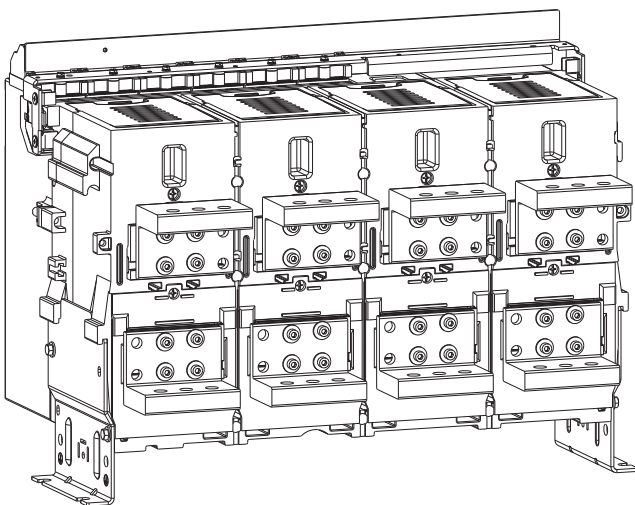

M12 / Equivalent BS bolts to be used for links termination. Tightening torque: 3.2 kgfm

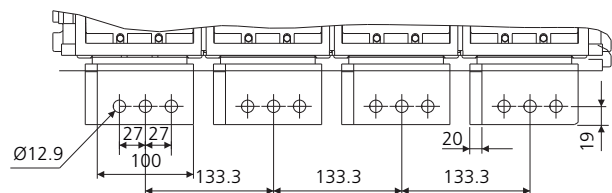
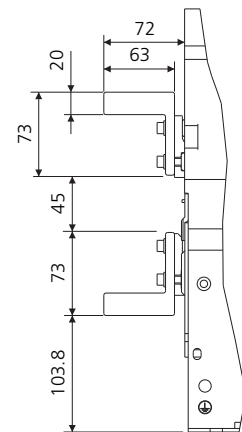

Details of 4P (200% N) on request. All Dimensions in mm All Dimensions in mm

Vertical Termination

400-3200A N/S/H & 4000A S/H Fr.2-4P (100% N)

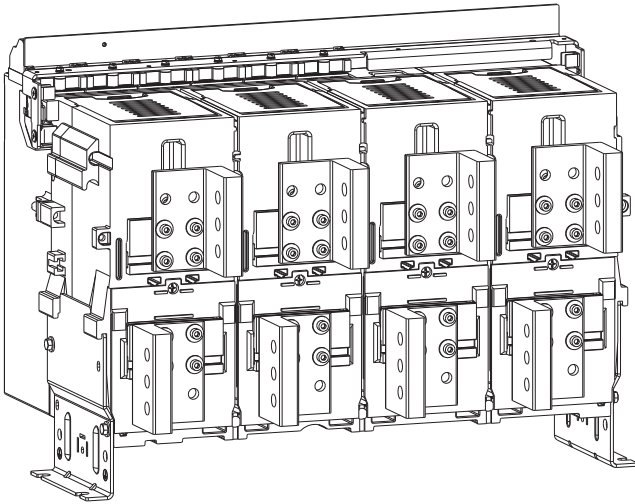

M12 / Equivalent BS bolts to be used for links termination.
Tightening torque: 3.2 kgfm

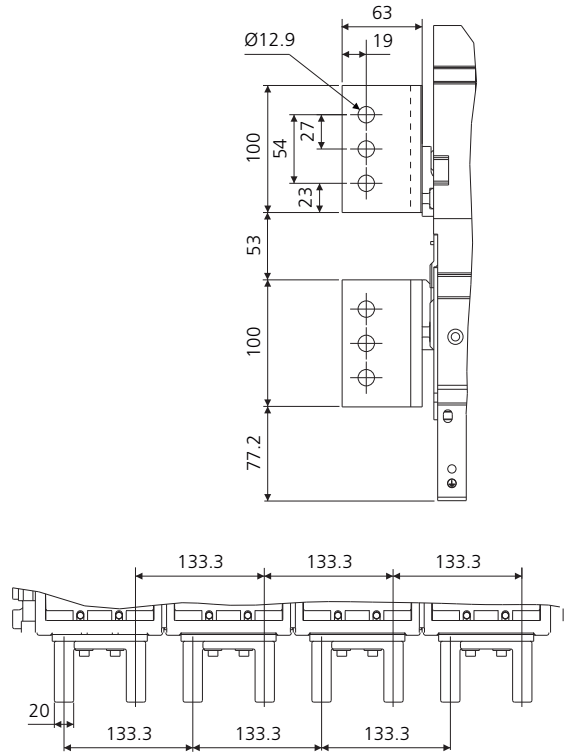

Top Horizontal & Bottom Vertical Termination

4000A S/H Fr.2-4P

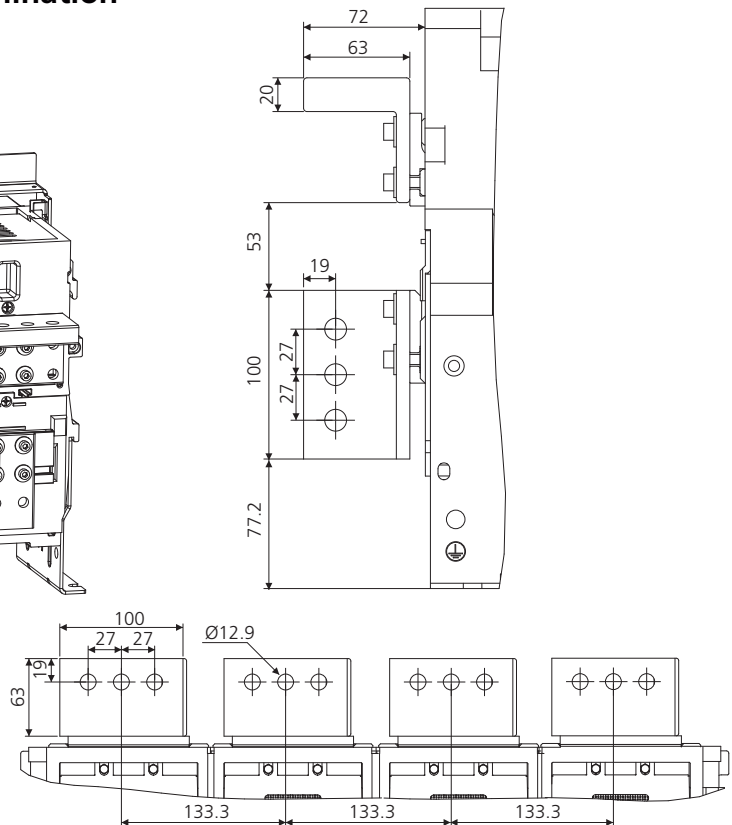
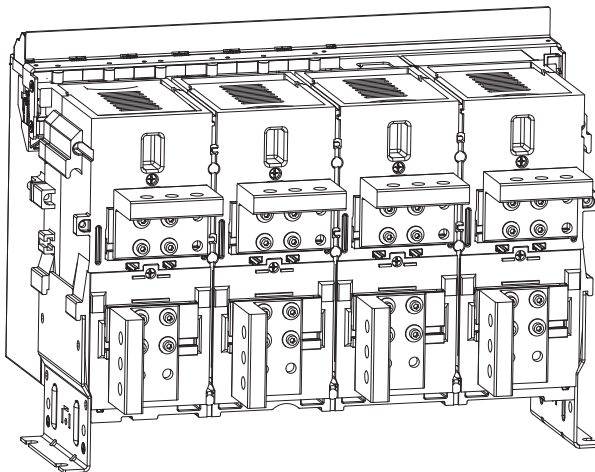

All Dimensions in mm

400-4000A H/V Fr.3 3P Flat Termination 400-1600A

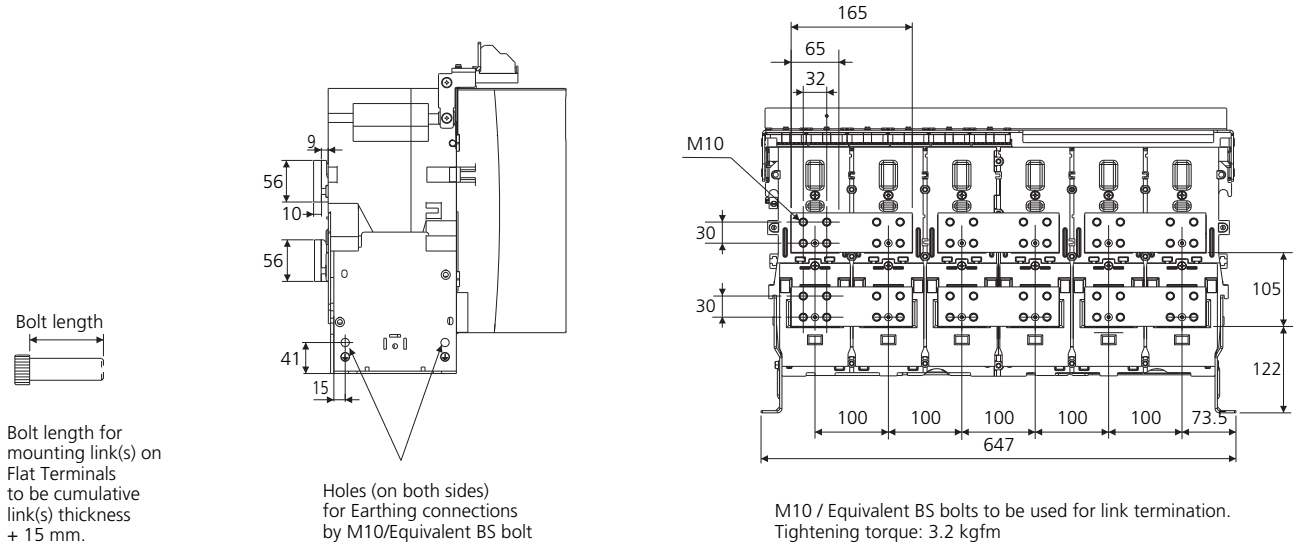

400-4000A H/V Fr.3 3P Horizontal Termination

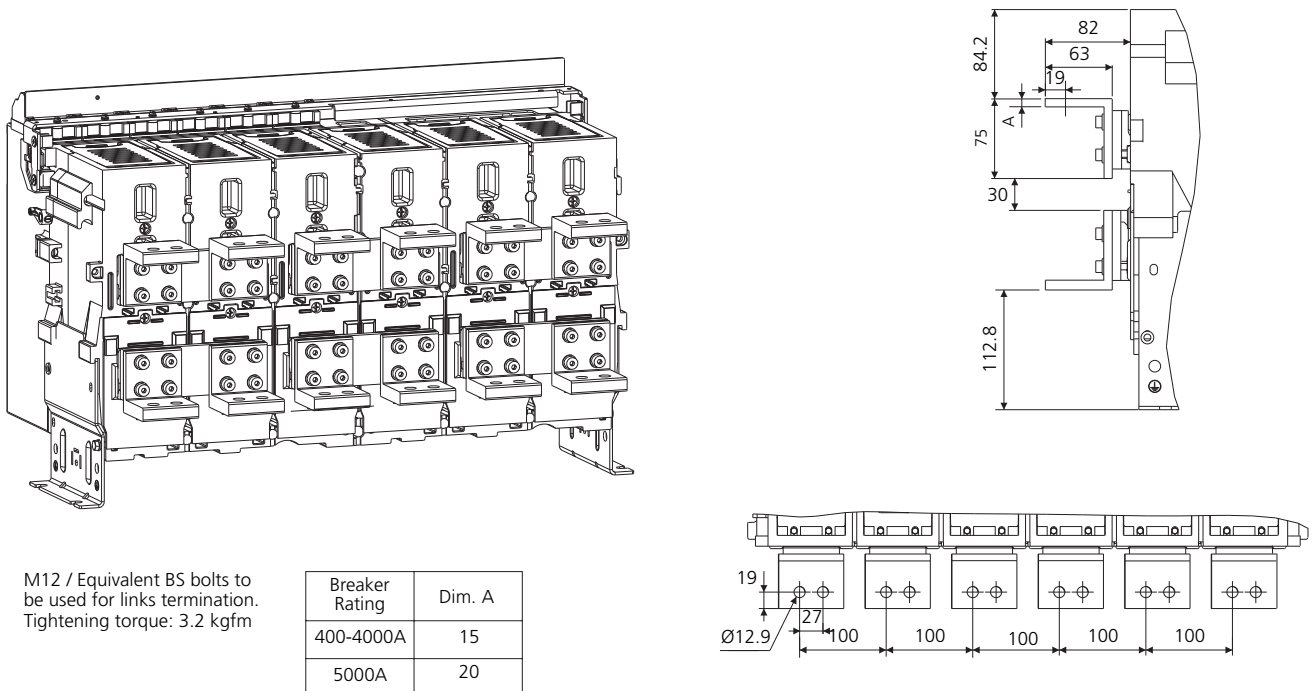

All Dimensions in mm

400-5000A H/V Fr.3 3P
Vertical Termination

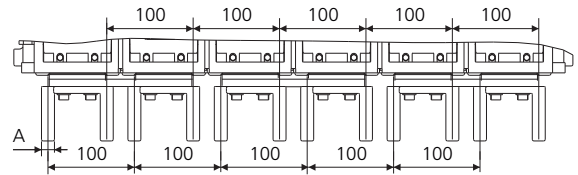
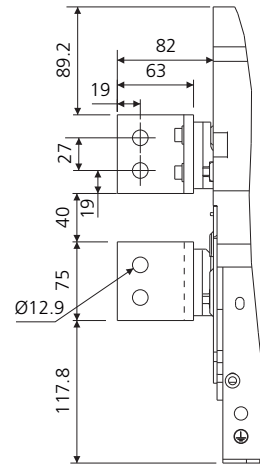
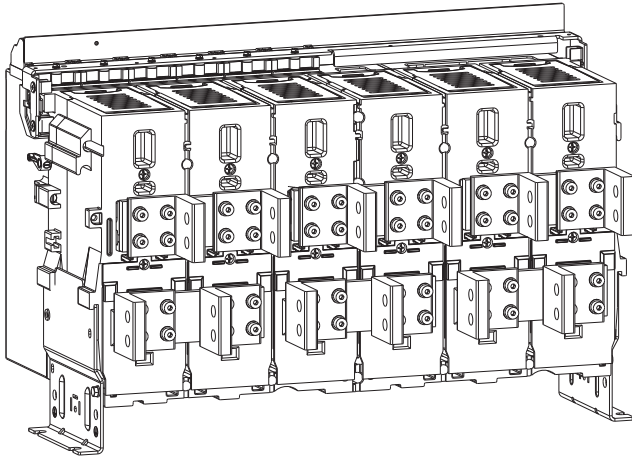

Breaker Rating	Dim. A
400-4000A	15
5000A	20

M12 / Equivalent BS bolts to be used for links termination
 Tightening torque: 3.2 kgfm

6300A H/V Fr.3 3P
Vertical Termination

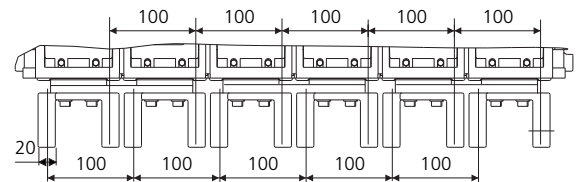
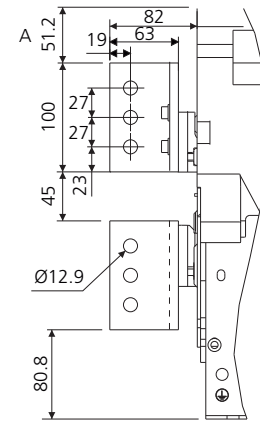
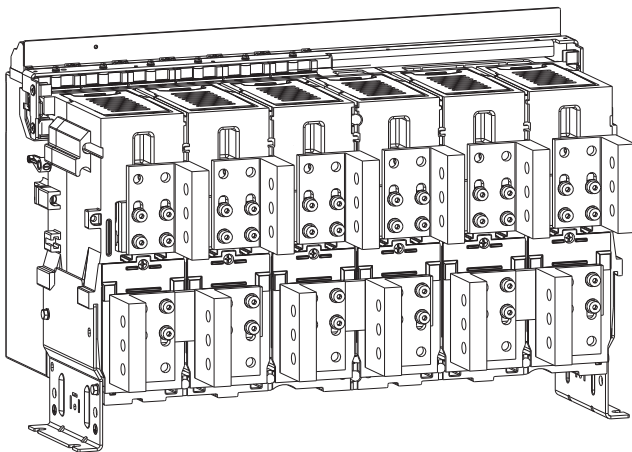

M12 / Equivalent BS bolts to be used for links termination.
 Tightening torque: 3.2 kgfm

All Dimensions in mm

400-5000A H/V Fr.3 4P (100% N) Flat Termination 400-1600A

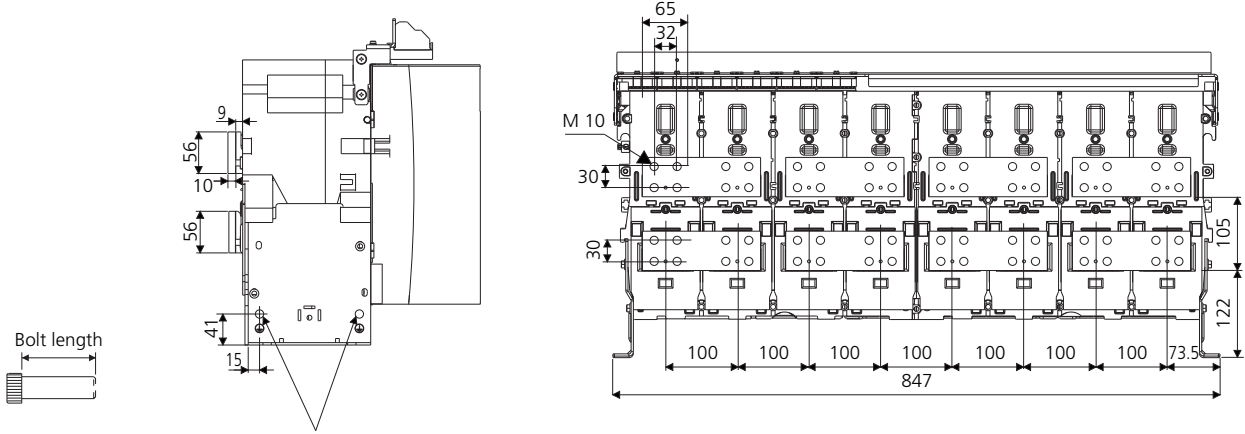

Bolt length for mounting link(s) on Flat Terminals to be cumulative link(s) thickness + 15 mm.

Holes (on both sides) for Earthing connections by M10/Equivalent BS bolt

M10 / Equivalent BS bolts to be used for links termination. Tightening torque: 3.2kgfm

400-4000A H/V Fr.3 4P (100% N) Horizontal Termination

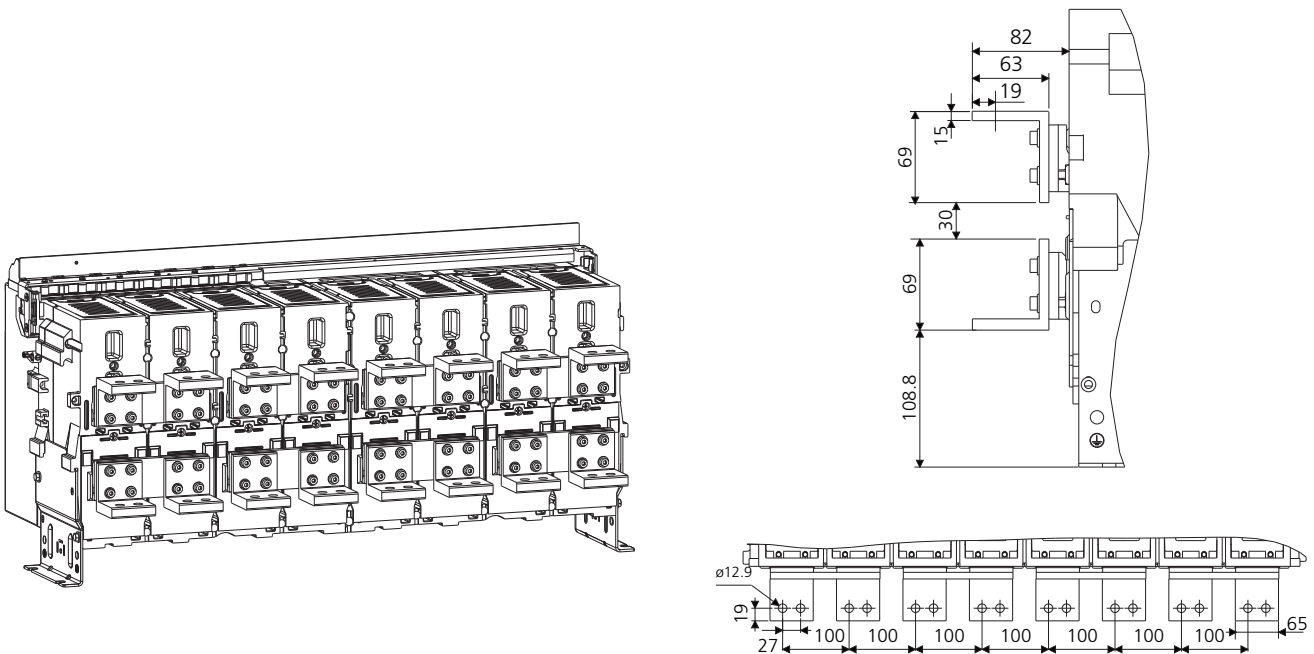

Details of 4P(50% N) on request.

M12 / Equivalent BS bolts to be used for links termination. Tightening torque: 3.2 kgfm

All Dimensions in mm

**400-5000A H/V Fr.3 4P (100% N)
Vertical Termination**

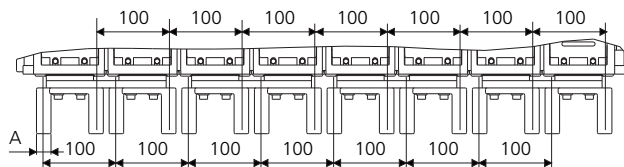
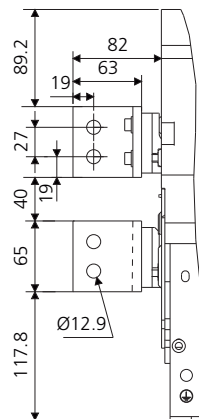
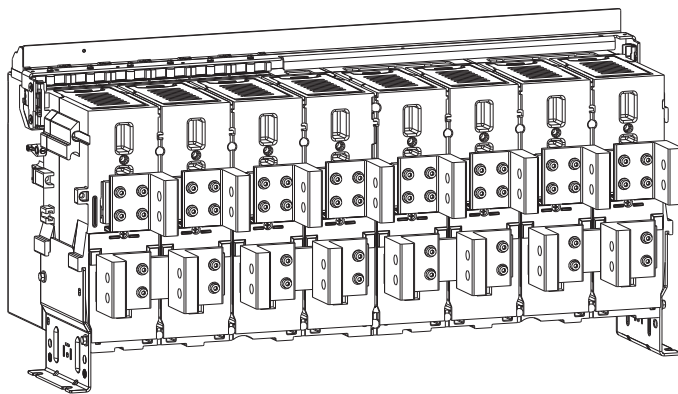

M12 / Equivalent BS bolts to be used for links termination.
Tightening torque: 3.2 kgfm

Breaker Rating	Dim. A
400-4000A	15
5000A	20

**6300A H/V Fr.3 4P (100% N)
Vertical Termination**

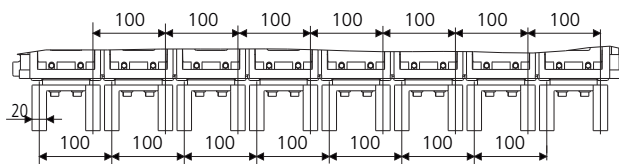
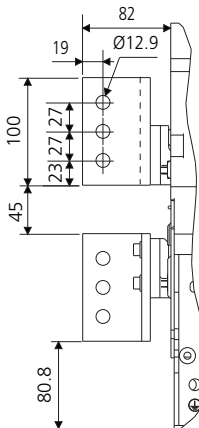
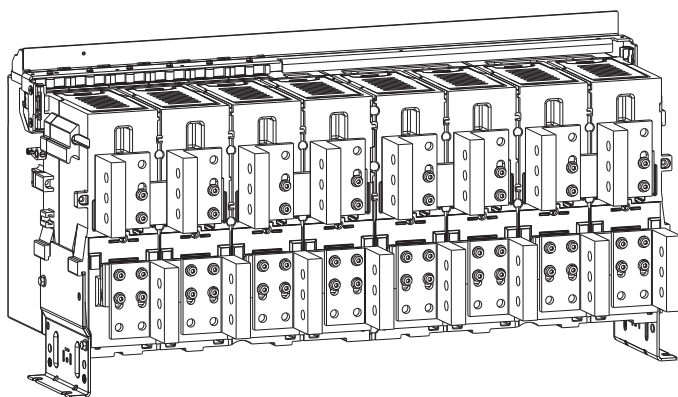

M12 / Equivalent BS bolts to be used for links termination.
Tightening torque: 3.2 kgfm

All Dimensions in mm

400A-1600A N/S/H, Fr.1 3P Flat Terminals

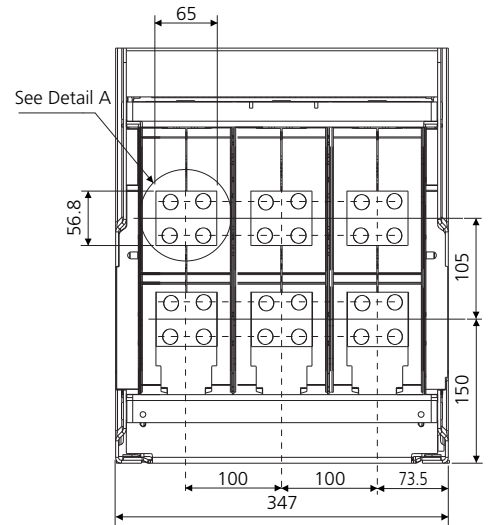
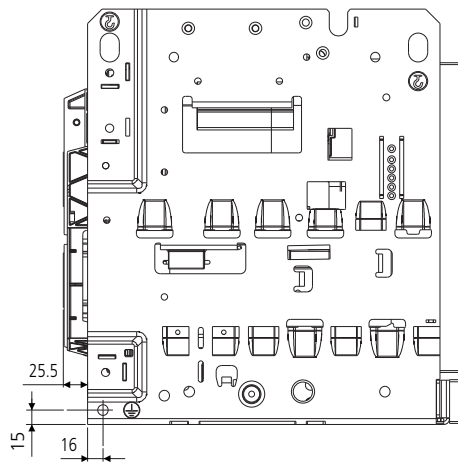
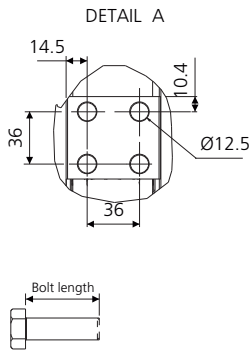

Bolt length for mounting link(s) on Flat Terminals to be cumulative link(s) Thickness + 20 min to 25 max

M12/ Equivalent BS bolts to be used for links termination. Tightening torque: 3.2 kgfm

Horizontal Terminals 400A-2000A N/S/H

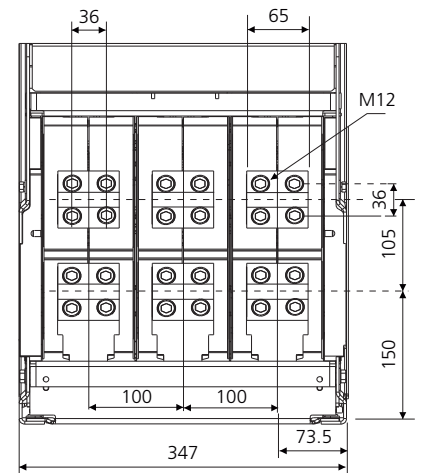
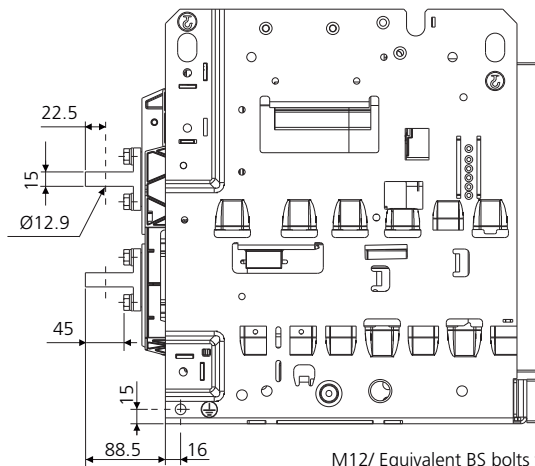

M12/ Equivalent BS bolts to be used for links termination. Tightening torque: 3.2 kgfm

Vertical Terminals 400A-2000A N/S/H

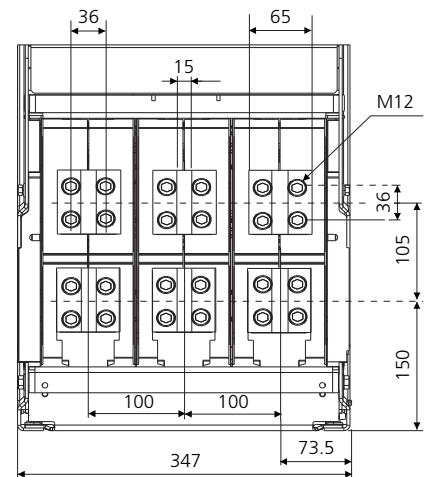
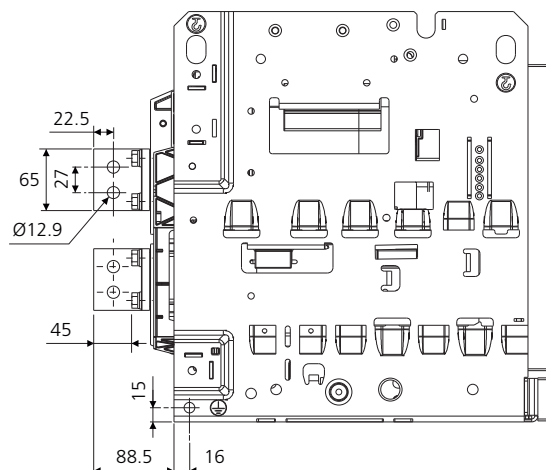

M12 / Equivalent BS bolts to be used for links termination Tightening torque: 3.2 kgfm

All Dimensions in mm

2500A S & 400-2500A H Fr.1-3P
Vertical Terminals

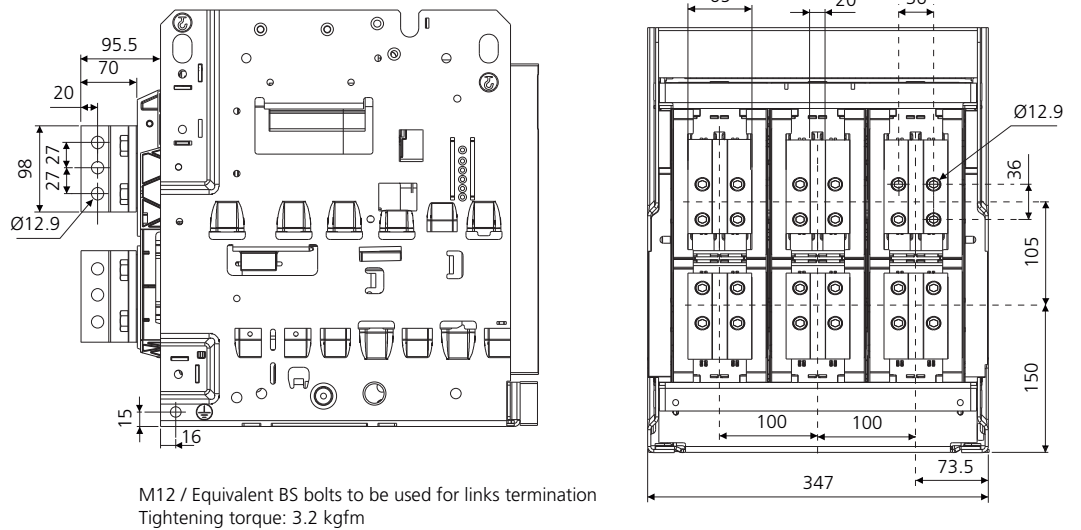

400A-2000A, N/S/H Fr.1-4P (100%N)
Flat Terminals
400A- 1600A, N/S/H

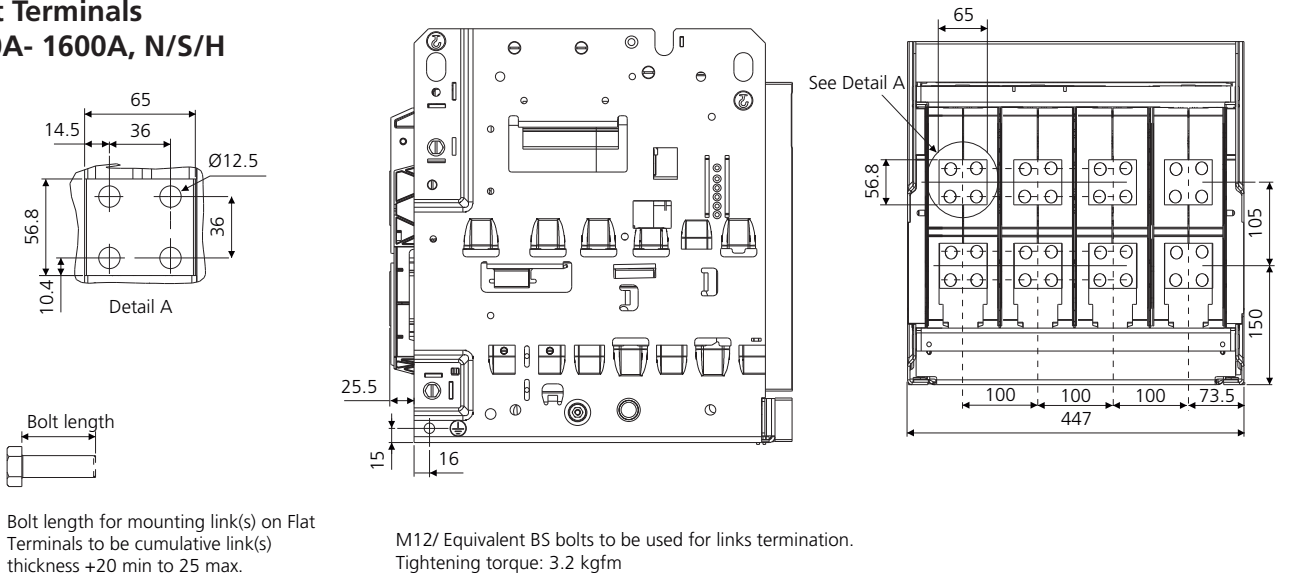

Horizontal Terminals
400A - 2000A N/S/H

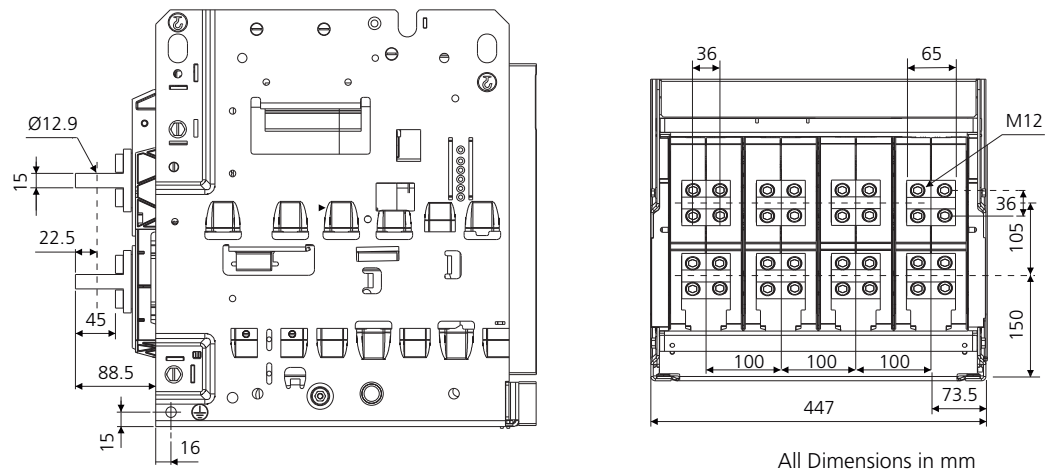

Vertical Terminals 400A - 2000A N/S/H

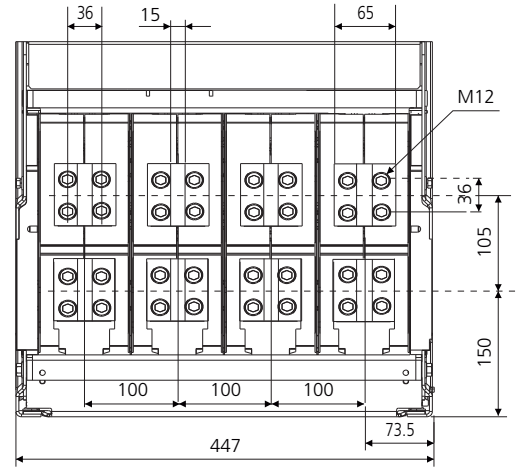
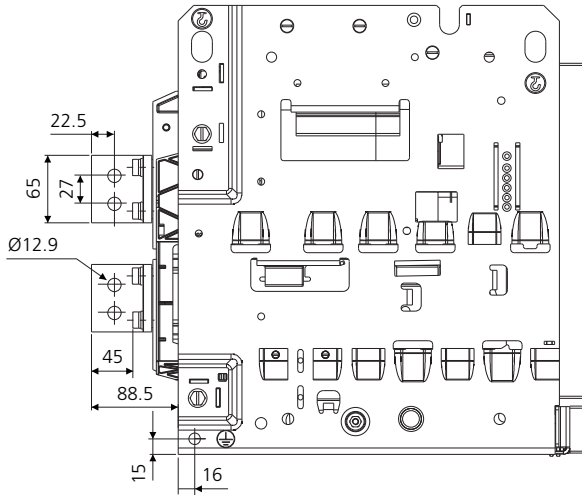

M12 / Equivalent BS bolts to be used for links termination
Tightening torque: 3.2 kgfm

Vertical Terminals 2500A S & 400-2500A H, Fr.1-4P (100%N)

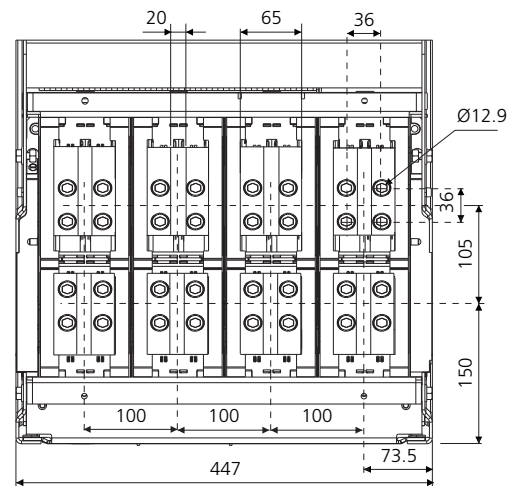
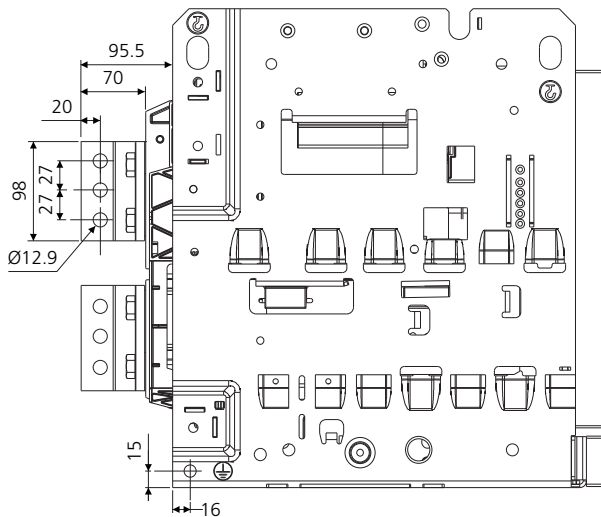

M12/ Equivalent BS bolts to be used for links termination.
Tightening torque: 3.2 kgfm

All Dimensions in mm

400A-3200A, N/S/H Fr.2-3P

Flat Terminals

400A-1600A, N/S/H

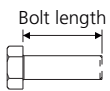
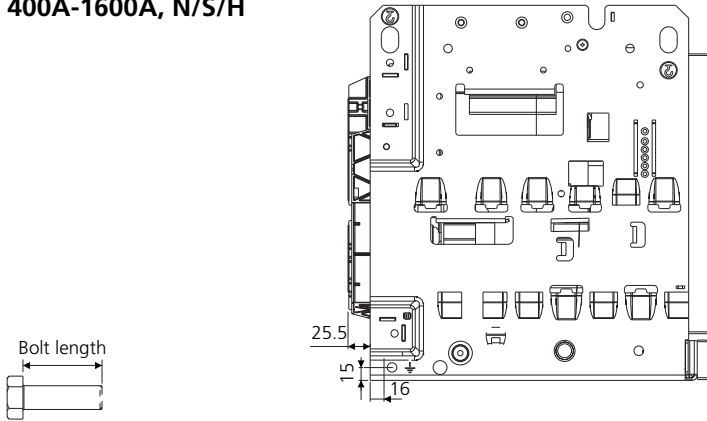

Bolt length for mounting link(s) on Flat Terminals to be cumulative link(s) thickness+20 min to 25 max

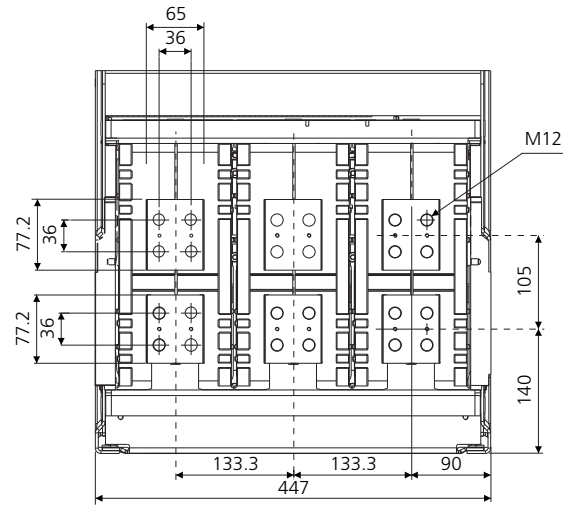

M12/ Equivalent BS bolts to be used for links termination. Tightening torque: 3.2 kgfm

Horizontal Terminals

400A-3200A, N/S/H

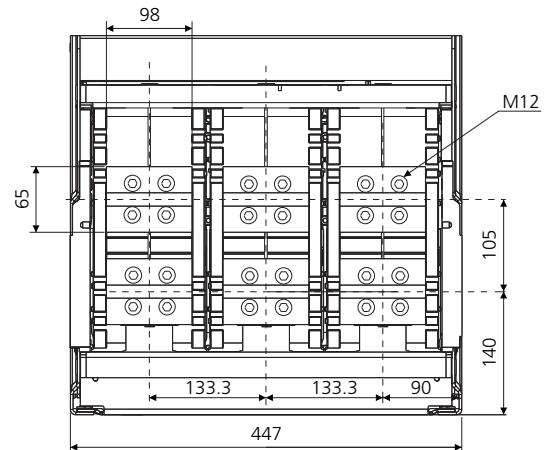
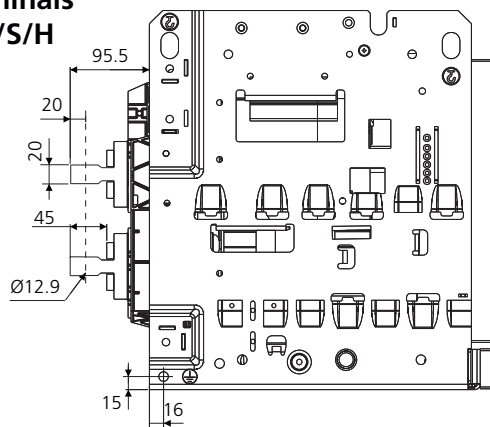

M12/ Equivalent BS bolts to be used for links termination. Tightening torque: 3.2 kgfm

Vertical Terminals

400A-3200A, N/S/H

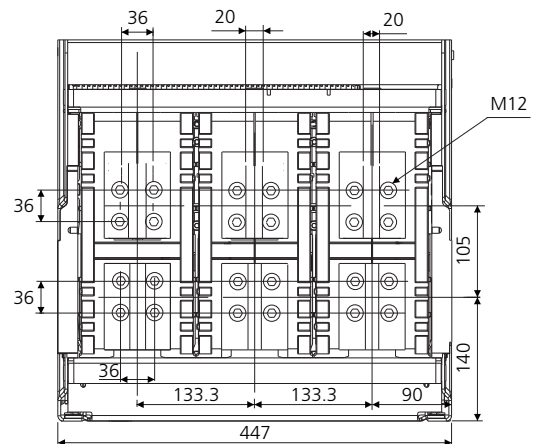
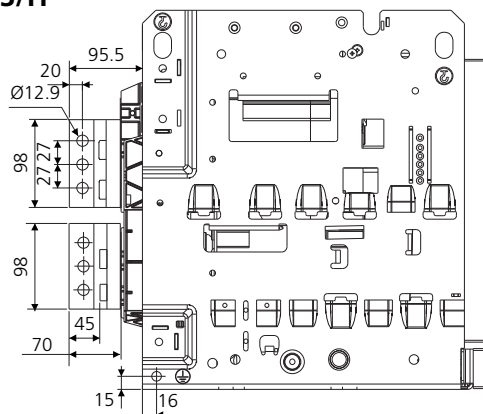

M12 / Equivalent BS bolts to be used for links termination. Tightening torque: 3.2 kgfm

All Dimensions in mm

4000A S/H Fr.2-3P

Vertical Terminals

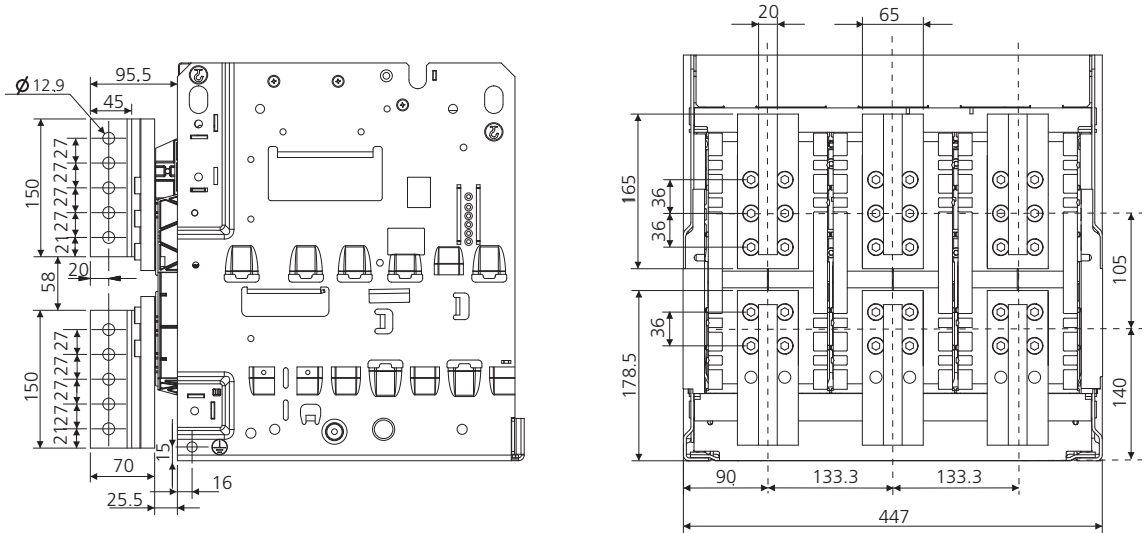

4000A S/H Fr.2-3P

Top Horizontal & Bottom Vertical Terminals

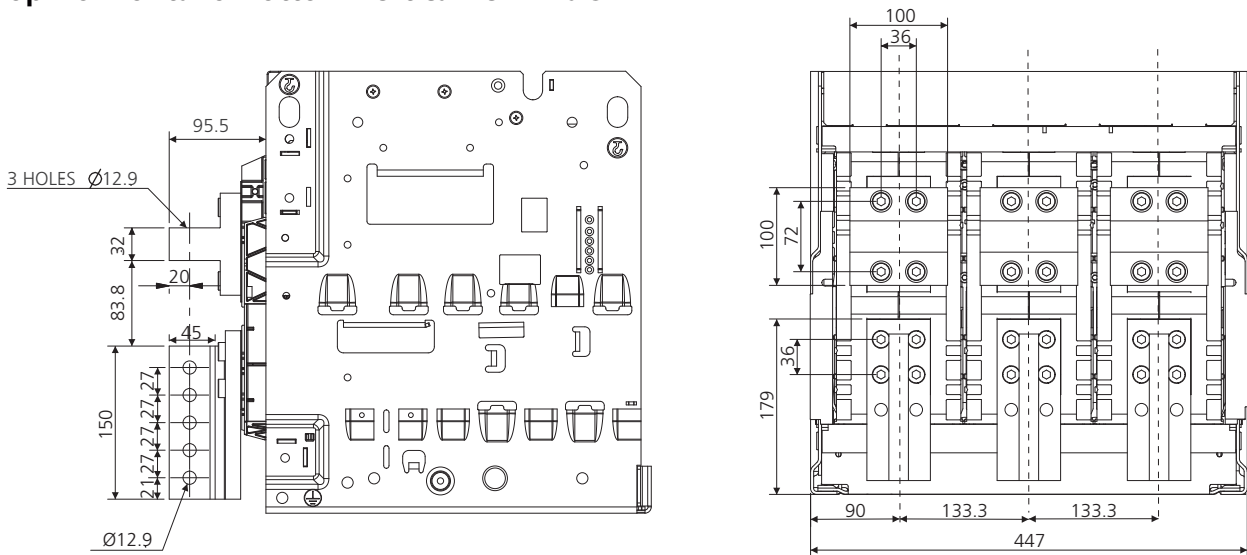

Horizontal: CL603160000

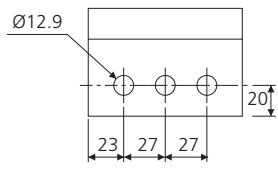

M12 / Equivalent BS bolts to be used for links termination.
Tightening torque: 3.2 kgfm

400A-3200A,N/S/H,Fr.2-4P (100% N)

Flat Terminals
400A-1600A,N/S/H

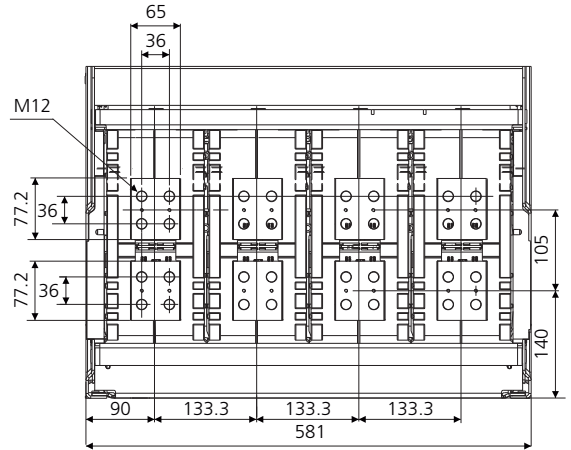
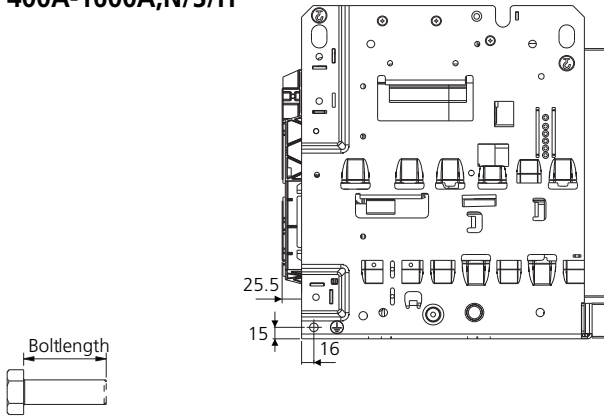

Bolt length for mounting link(s) on Flat Terminals to be cumulative link(s) thickness+20 min to 25 max

M12/ Equivalent BS bolts to be used for links termination.
Tightening torque: 3.2 kgfm

Horizontal Terminals
400A-3200A N/S/H

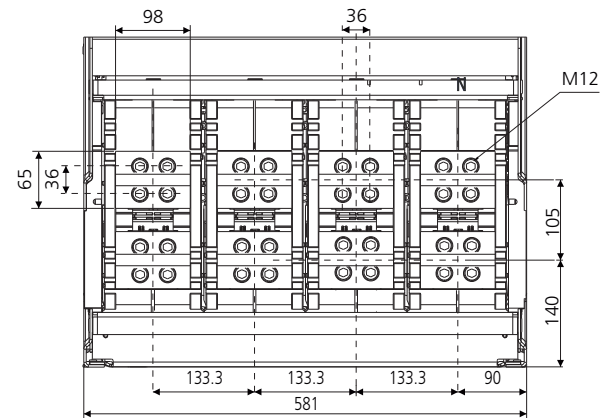
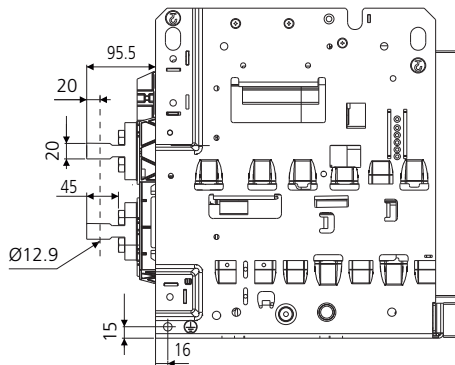

M12/ Equivalent BS bolts to be used for links termination.
Tightening torque: 3.2 kgfm

Vertical Terminals
400A-3200A N/S/H

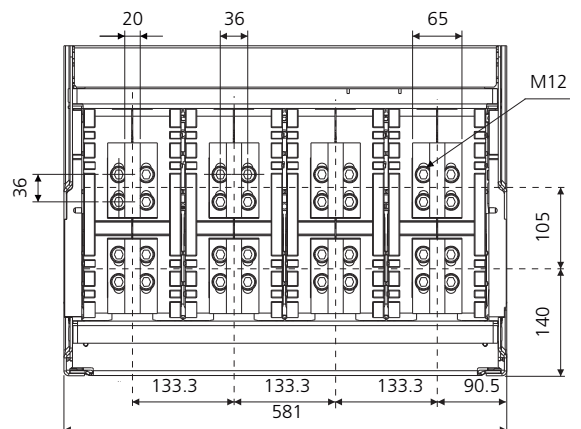
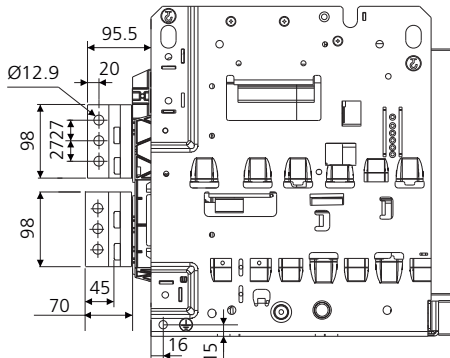

M12 / Equivalent BS bolts to be used for links termination.
Tightening torque: 3.2kgfm

All Dimensions in mm

4000A S/H Fr.2-4P Vertical Terminals

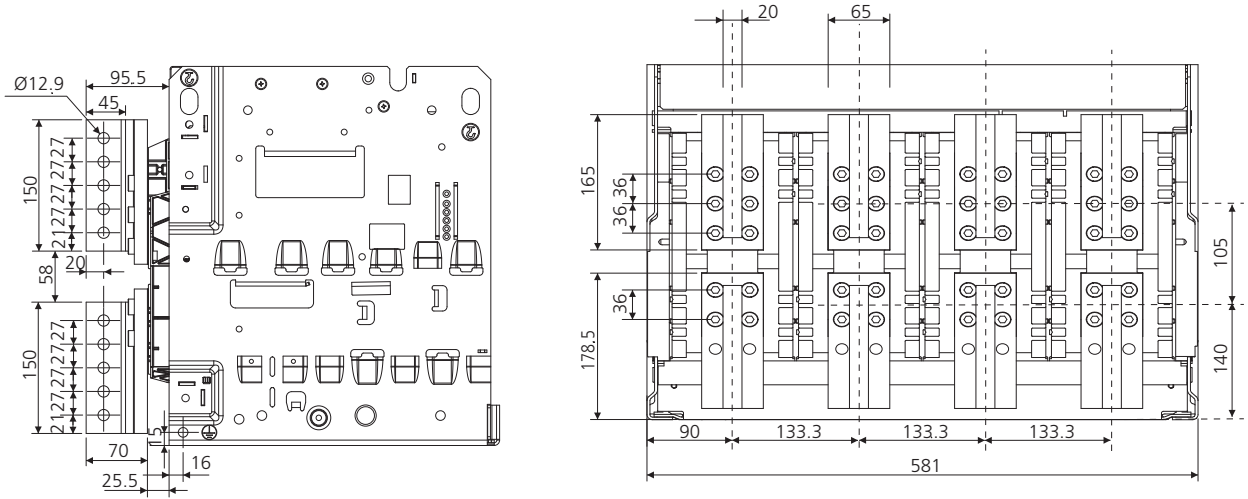

4000A S/H Fr.2-4P Top Horizontal & Bottom Vertical Terminals

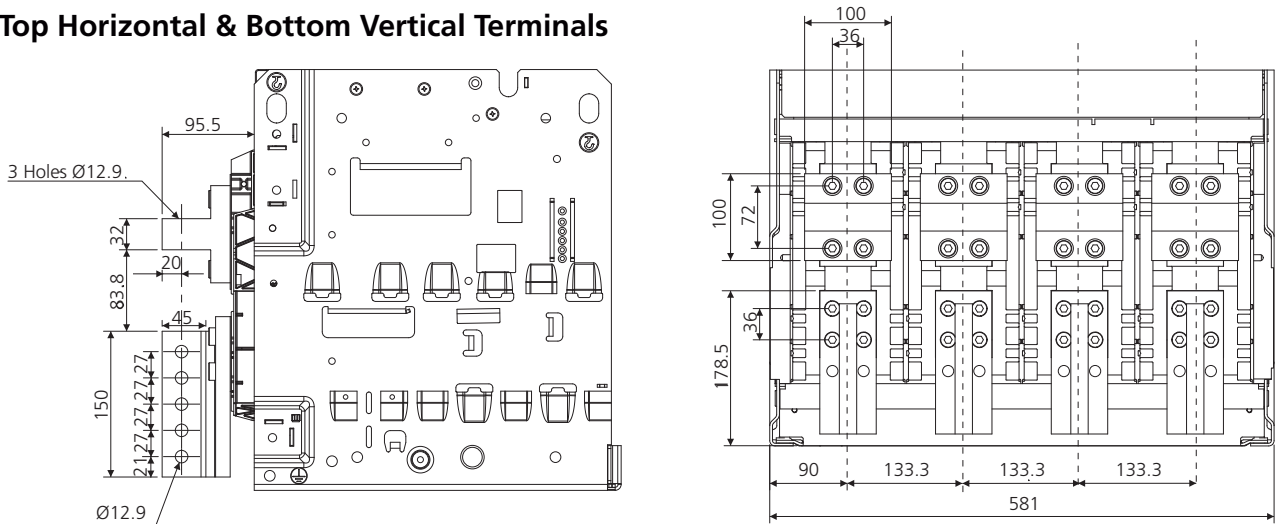

Horizontal: CL603160000

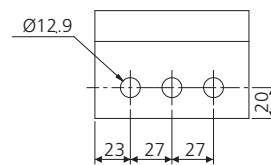

M12 / Equivalent BS bolts to be used for links termination.
Tightening torque: 3.2 kgfm

All Dimensions in mm

400-4000A H/V Fr.3 3P

Flat Terminals

400-1600A

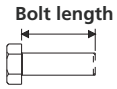

Bolt length for mounting link(s) on Flat Terminals to be cumulative link(s) thickness +20 min to 25 max

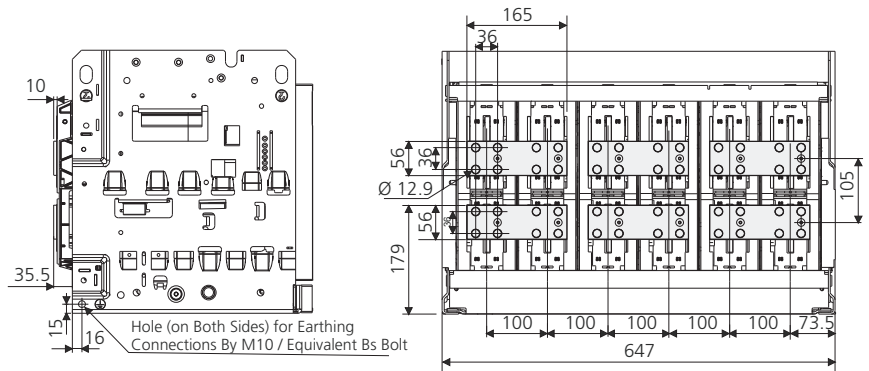

M12/ Equivalent BS bolts to be used for links termination. Tightening torque: 3.2 kgfm

Horizontal Terminals

400-4000A H/V

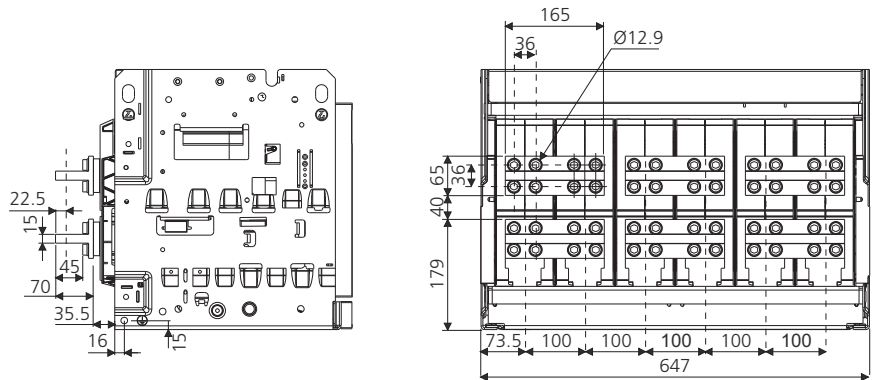
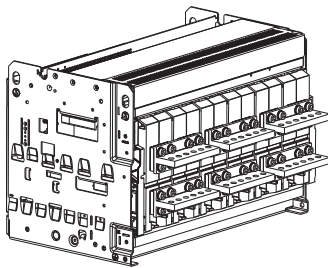

M12 / Equivalent BS bolts to be used for links termination. Tightening torque: 3.2 kgfm

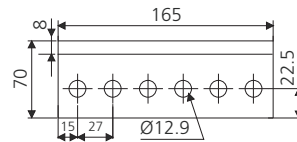

Vertical Terminals

400-4000A H/V

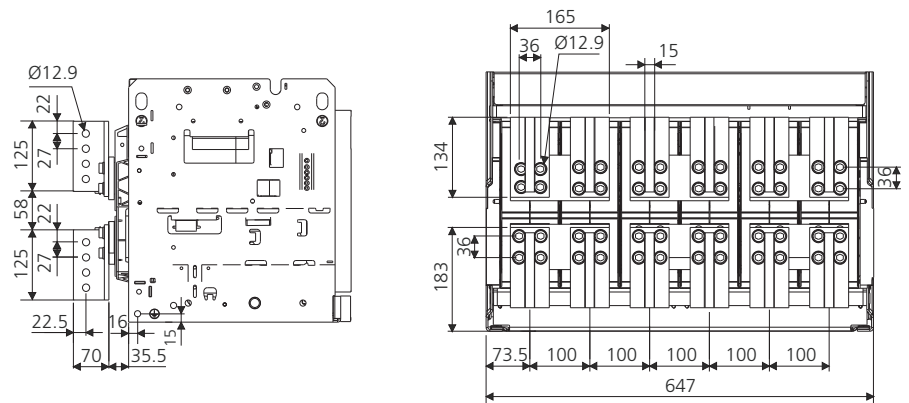
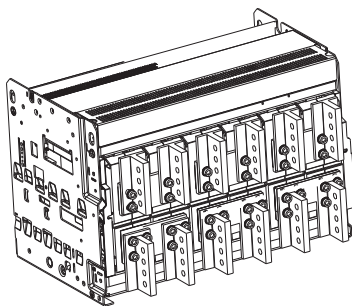

M12/Equivalent BS bolts to be used for links termination Tightening torque: 3.2 kgfm

All Dimensions in mm

5000-6300A H/V Fr.3 3P

Horizontal Terminals 5000A

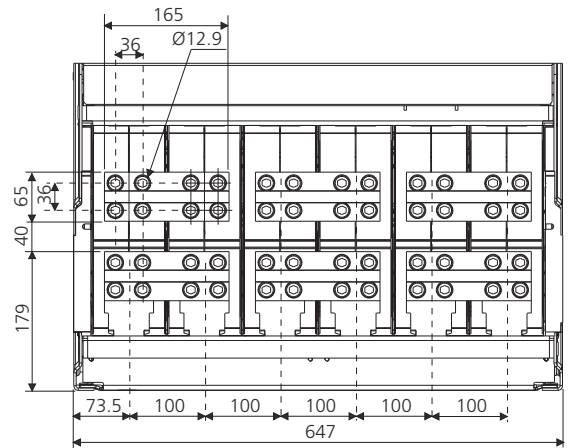
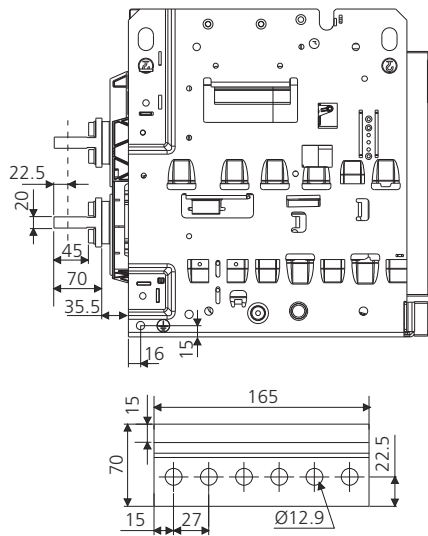
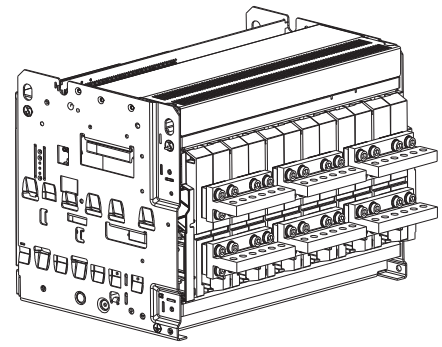

* H-H termination recommended for bus coupler only

M12/ Equivalent BS bolts to be used for links termination.
Tightening torque: 3.2 kgfm

Vertical Terminals 5000A

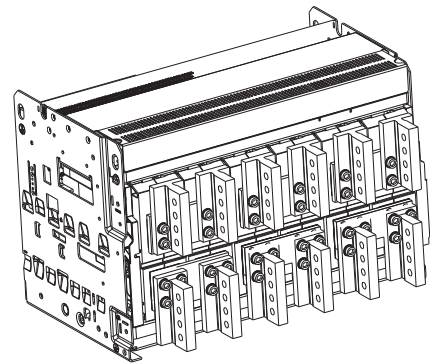

M12/ Equivalent BS bolts to be used for links termination.
Tightening torque: 3.2 kgfm

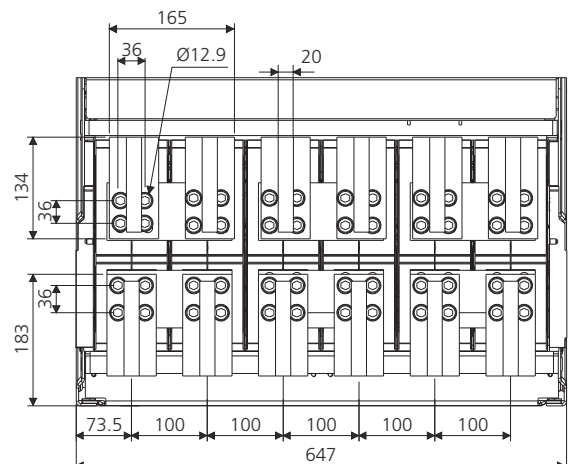
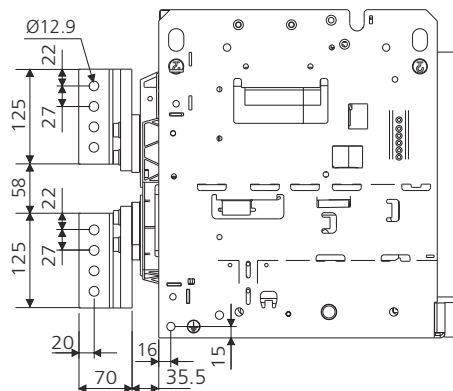

All Dimensions in mm

Vertical Terminals

6300A

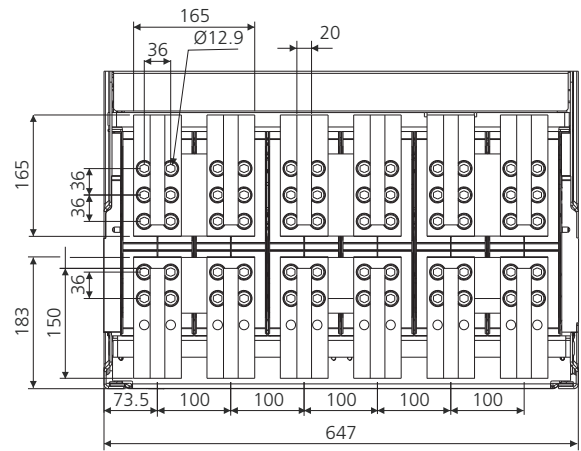
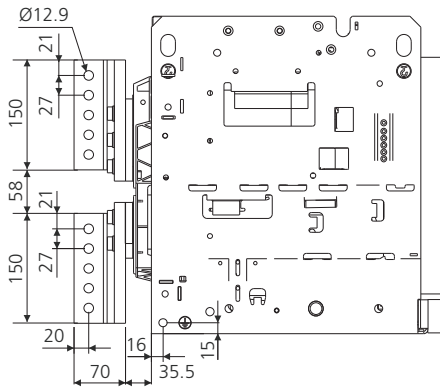
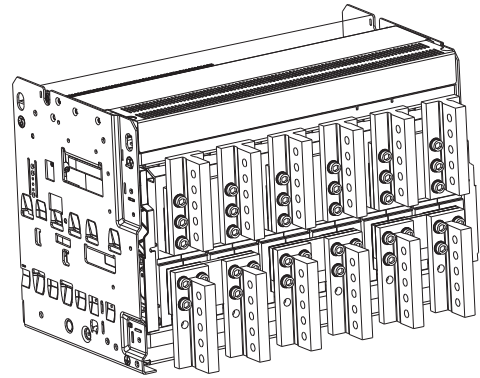

M12/ Equivalent BS bolts to be used for links termination.
Tightening torque: 3.2 kgfm

All Dimensions in mm

400A-5000A H/V Fr.3-4P (50% N)

Flat Terminals 400A-1600A H/V

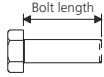

Bolt length for mounting link(s) on Flat Terminals to be cumulative link(s) thickness+20 min to 25 max

M12/ Equivalent BS bolts to be used for links termination.
Tightening torque: 3.2 kgfm

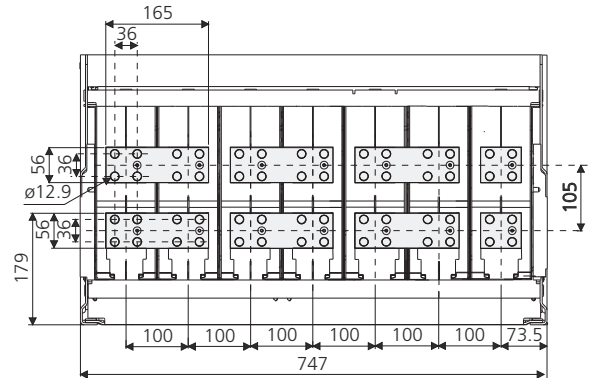
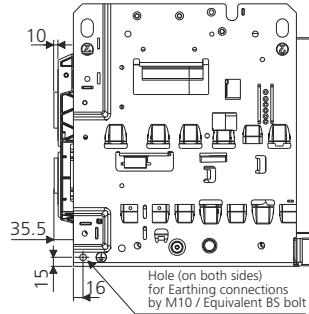

Horizontal Terminals 400A-4000A H/V

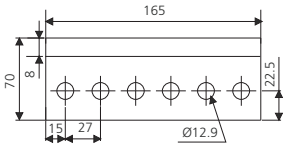

M12/ Equivalent BS bolts to be used for links termination.
Tightening torque: 3.2 kgfm

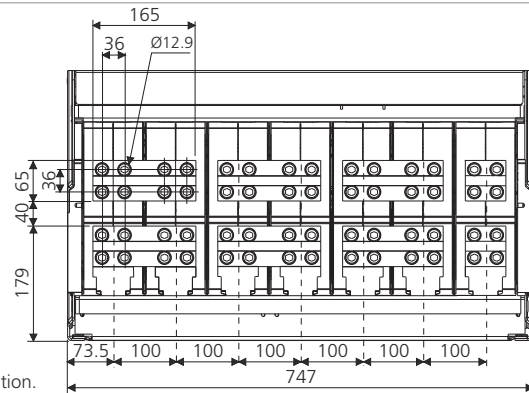
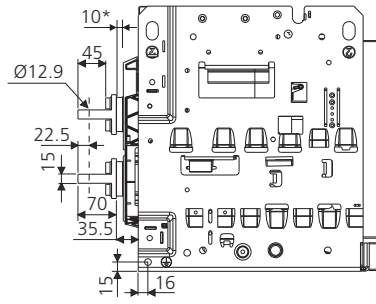

Vertical Terminals 400A-4000A H/V

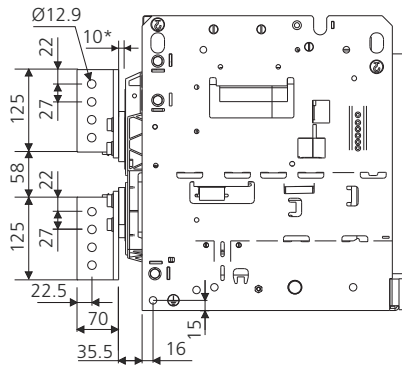

M12/ Equivalent BS bolts to be used for links termination.
Tightening torque: 3.2 kgfm

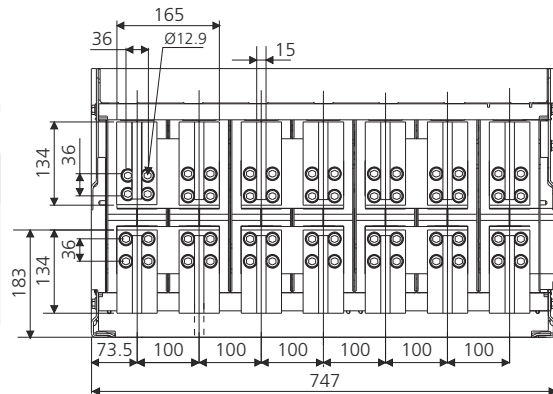

Vertical Terminals 5000A H/V

M12/Equivalent BS bolts to be used for link termination
Tightening torque: 3.2 kgfm

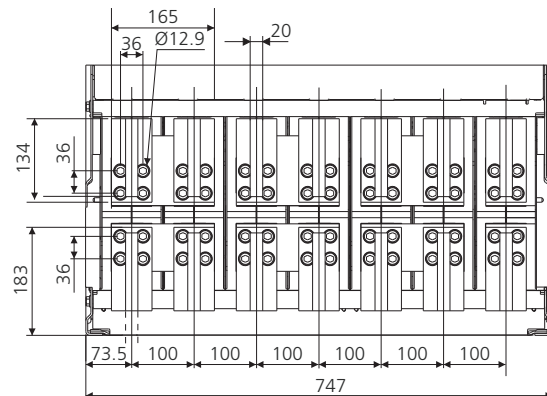
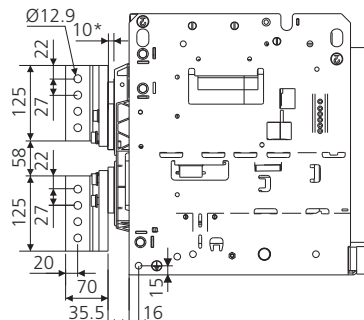

All Dimensions in mm

* 10 mm Terminal Height difference due to equalizer for Neutral

400-4000A H/V Fr.3 4P (100% N)

Flat Terminals 400-1600A

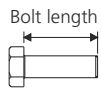

Bolt length for mounting link(s) on Flat Terminals to be cumulative link(s) thickness +20 min to 25 max

M12/ Equivalent BS bolts to be used for links termination.
Tightening torque: 3.2 kgfm

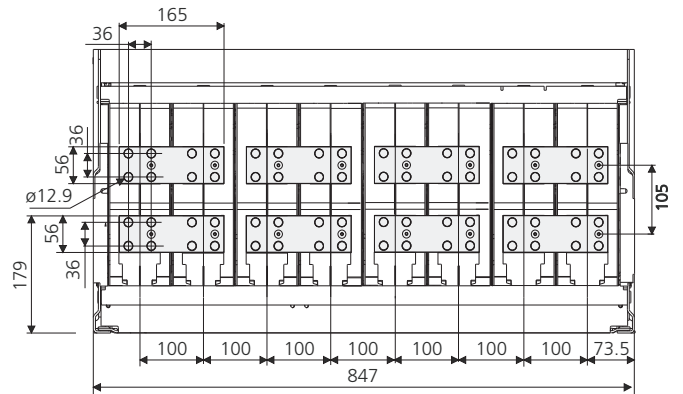
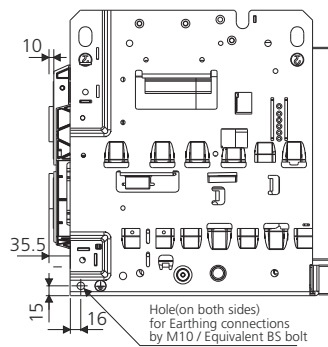

Horizontal Terminals 400-4000A

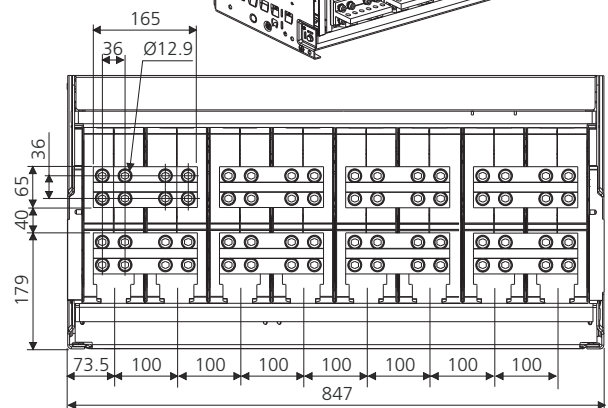
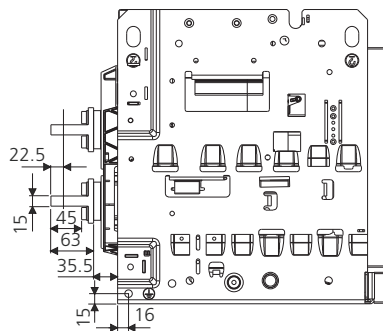
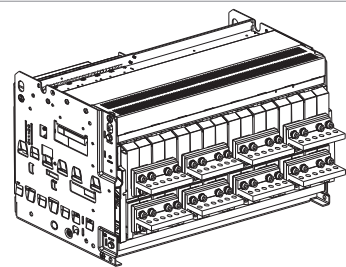
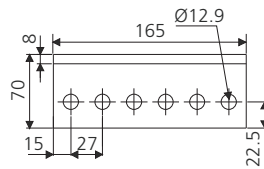

M12/ Equivalent BS bolts to be used for links termination.
Tightening torque: 3.2 kgfm

Vertical Terminals 400-4000A

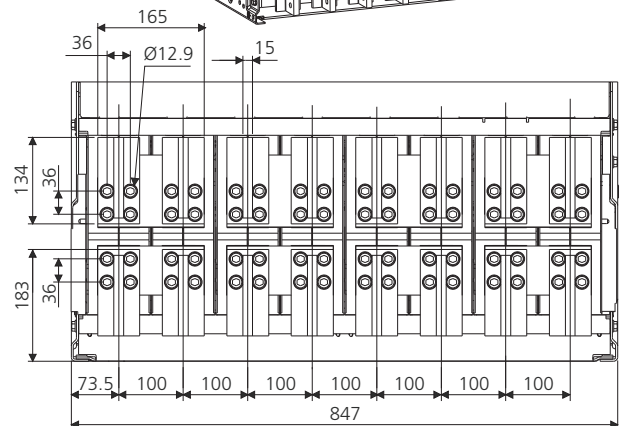
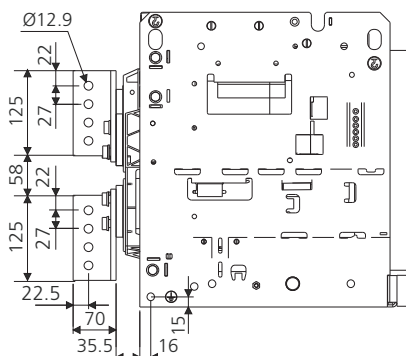
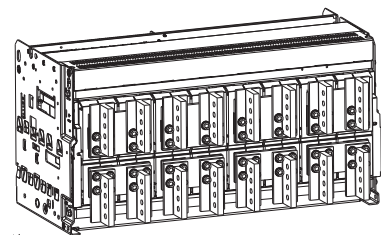

M12/Equivalent BS bolts to be used for links termination Tightening torque: 3.2 kgfm

All Dimensions in mm

400-6300A H/V Fr.3 4P (100% N) Horizontal Terminals 5000A

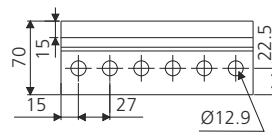
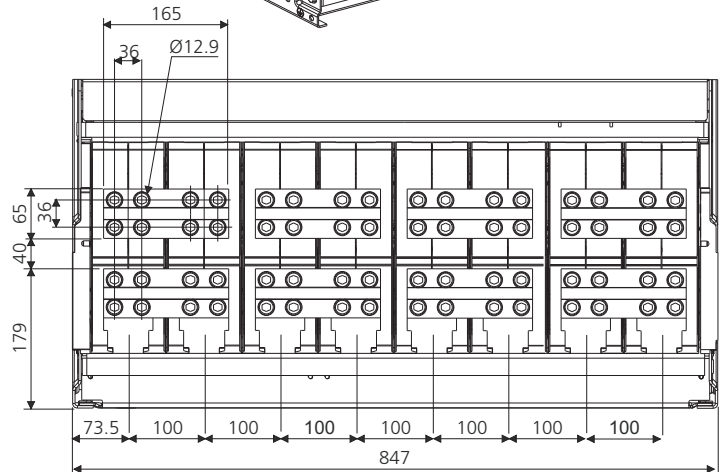
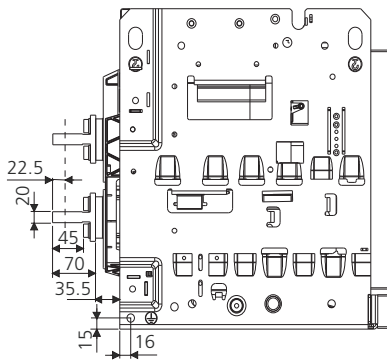
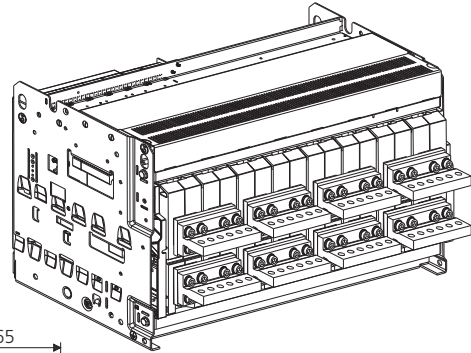

M12/ Equivalent BS bolts to be used for links termination.
Tightening torque: 3.2 kgfm

Vertical Terminals 5000A

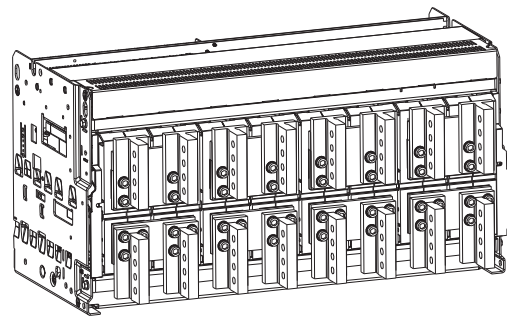

M12/ Equivalent BS bolts to be used for links termination.
Tightening torque: 3.2 kgfm

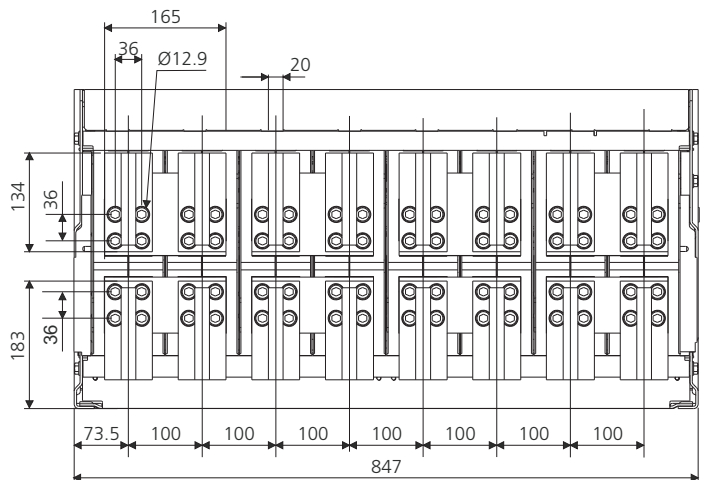
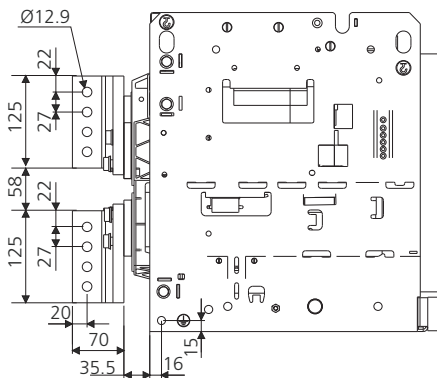

All Dimensions in mm

Vertical Terminals 6300A

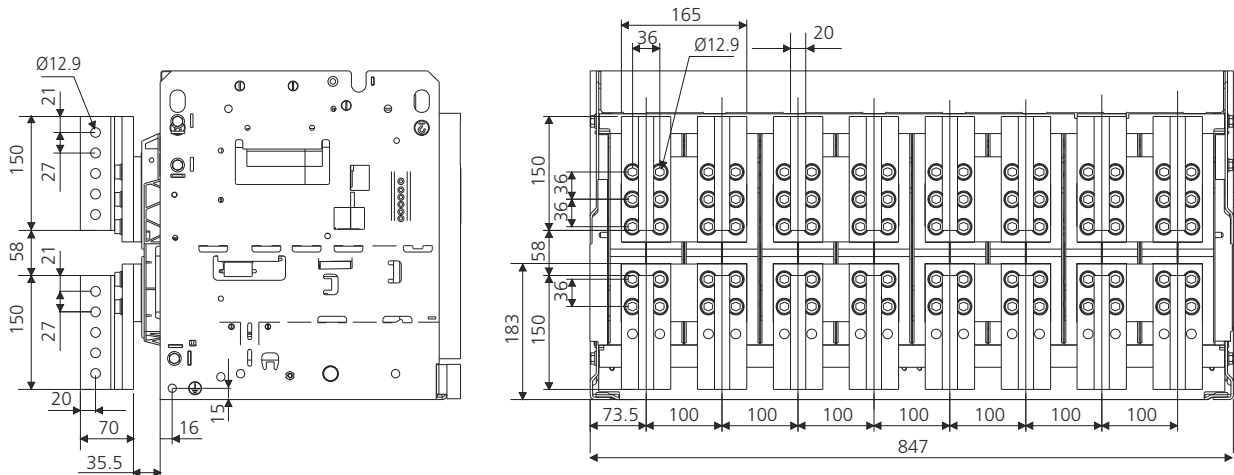
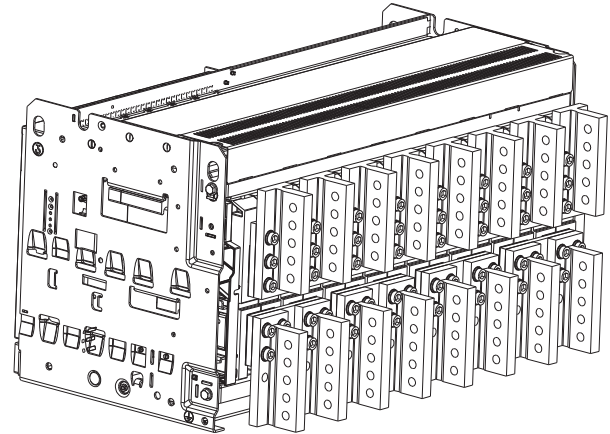

M12/ Equivalent BS bolts to be used for links termination.
Tightening torque: 3.2 kgfm

400A-2000A H/V,Fr.3-4P (200%N)*
Flat Terminals
400A-1600A H/V

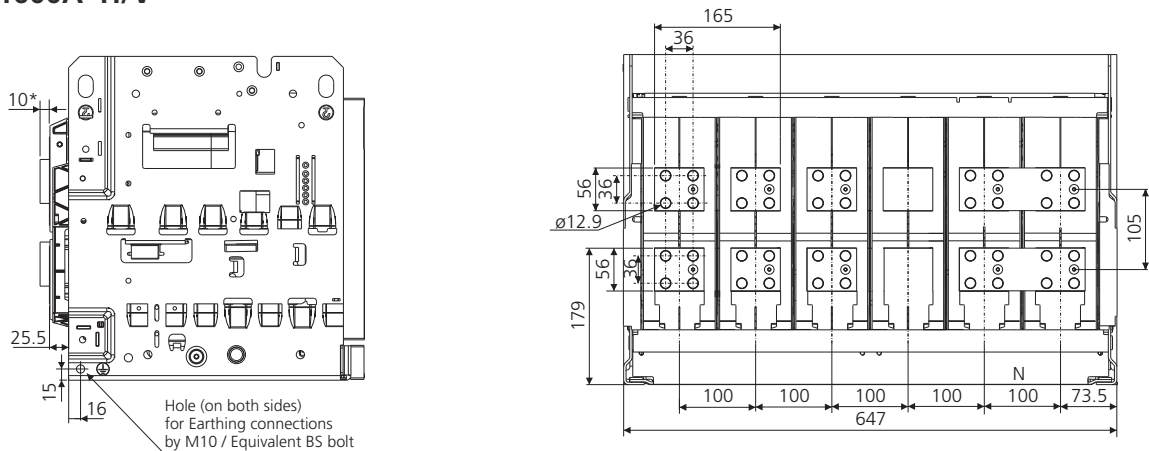

 Bolt length for mounting link(s) on Flat Terminals to be cumulative link(s) thickness+20 min to 25 max

*10 mm Terminal height difference due to equalizer for Neutral.

M 12/ Equivalent BS bolts to be used for links termination.
Tightening torque: 3.2 kgfm

*Option for 400-1250A Fr.1-4P 200%N and 400-1600A Fr.2-4P 200%N Also available.

All Dimensions in mm

Horizontal Terminals 400A-2000A H/V

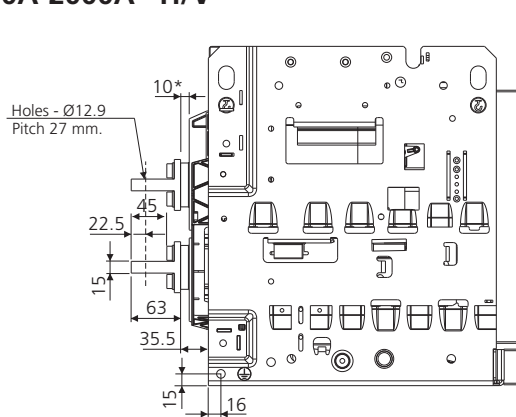

M12 / Equivalent BS bolts to be used for links termination.
Tightening torque: 3.2 kgfm

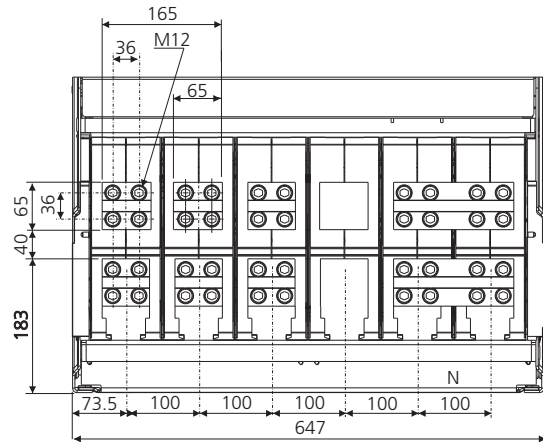

*10 mm Terminal height difference due to equalizer for Neutral.

Vertical Terminals 400A-2000A H/V

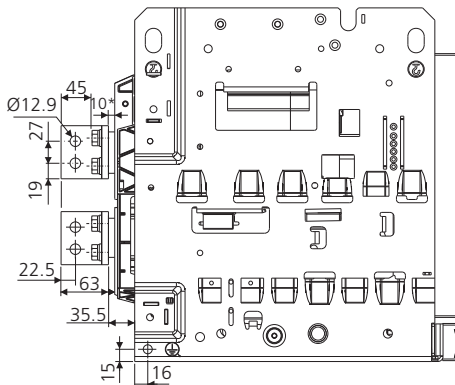

M12 / Equivalent BS bolts to be used for links termination.
Tightening torque: 3.2 kgfm

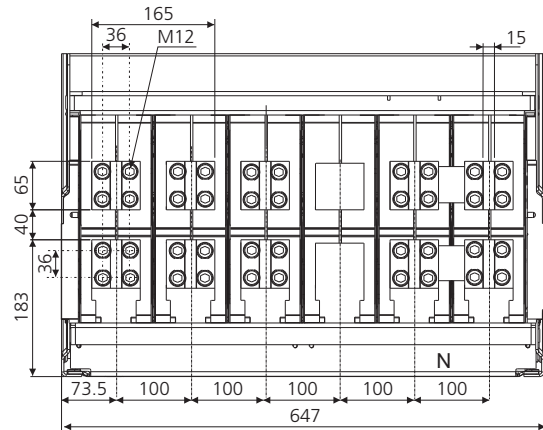

*10 mm Terminal height difference due to equalizer for Neutral.

Vertical Terminals FOR 2500A H/V, Fr.3-4P(200%N)

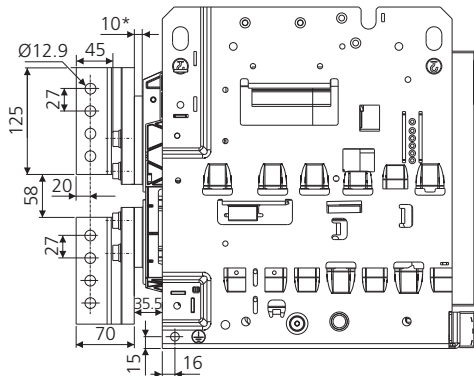

M12 / Equivalent BS bolts to be used for links termination.
Tightening torque: 3.2 kgfm

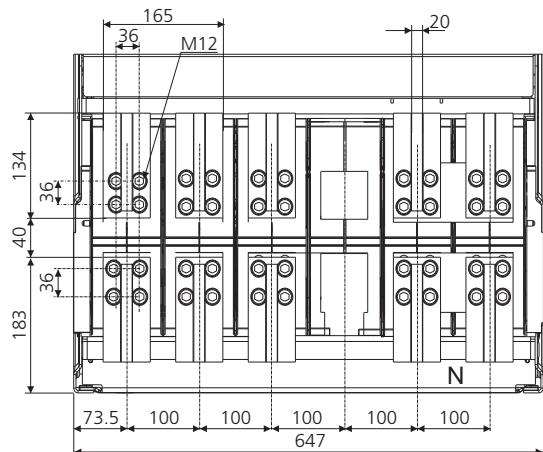

*10 mm Terminal height difference due to equalizer for Neutral.

All Dimensions in mm

Direct Aluminium termination

Frame-1 : 400 - 2000A N/S/H

Frame Size	Rating (A)	Aluminium cross section as per IS/IEC (in sq. mm)	Popular Aluminium Termination								
			Flat			Horizontal (with Terminal adaptor)			Vertical (with Terminal adaptor)		
			6 mm	10 mm	12 mm	6 mm	10 mm	12 mm	6 mm	10 mm	12 mm
1	800	800	50 - 3 runs 75 - 2 runs	-	75 - 1 runs	75 - 2 runs 50 - 3 runs	-	75 - 1 runs	75 - 2 runs 50 - 3 runs	-	75 - 1 runs
	1000	1000	-	50 - 2 runs	-	-	50 - 2 runs	-	-	50 - 2 runs	-
	1250	1512	-	75 - 2 runs	-	-	75 - 2 runs	-	-	75 - 2 runs	-
	1600	1600	-	60 - 3 runs	75 - 2 runs	-	60 - 3 runs	75 - 2 runs	-	60 - 3 runs	75 - 2 runs
	2000	3000	-	-	-	-	75 - 4 runs	-	-	75 - 4 runs 100 - 3 runs	-

Note: Above table is based on extensive study of popular bus-bar sizes used to terminate Air Circuit Breakers. However other bus-bar sizes (in terms of thickness & width) can also be used to achieve bus-bar cross section recommended by IS & IEC. De-rating of switchgear depends upon various factors such as cross section area, orientation and material of bus bar, healthiness of bus-bar joints, panel construction, and ventilation, etc.

Frame-2 : 400 - 3200A N and 400 - 4000A S/H

Frame Size	Rating (A)	Aluminium cross section as per IS/IEC (in sq. mm)	Popular Aluminium Termination					
			Horizontal (with Terminal adaptor)			Vertical (with Terminal adaptor)		
			6 mm	10 mm	12 mm	6 mm	10 mm	12 mm
2	2500	4000	-	100 - 4 runs	-	-	100 - 4 runs	-
	3200 ⁽²⁾	6000 ⁽¹⁾	-	-	100 - 5 runs	-	150 - 4 runs	-
	4000 ⁽²⁾	7200 ⁽¹⁾	-	-	100 - 6 runs	-	-	100 - 6 runs 150 - 4 runs

(1) Not as per standard but generally followed.

(2) Fr-2 3200, 4000 A recommended for Top Horizontal+Bottom Vertical & Top Vertical+Bottom Vertical configurations only.

Note: Above table is based on extensive study of popular bus-bar sizes used to terminate Air Circuit Breakers. However other bus-bar sizes (in terms of thickness & width) can also be used to achieve bus-bar cross section recommended by IS & IEC. De-rating of switchgear depends upon various factors such as cross section area, orientation and material of bus bar, healthiness of bus-bar joints, panel construction, and ventilation, etc.

All Dimensions in mm

Frame-3 : 400 - 6300A H/V

Frame Size	Rating (A)	Aluminium cross section as per IS/IEC (in sq. mm)	Popular Aluminium Termination					
			Horizontal (with Terminal adaptor)			Vertical (with Terminal adaptor)		
			6 mm	10 mm	12 mm	6 mm	10 mm	12 mm
3	4000	7200*	160 - 8 runs	150 - 5 runs	150 - 4 runs	-	125 - 6 runs	125 - 5 runs
	5000	8000*	Copper termination recommended					
	6300	10000*	Copper termination recommended					

*Not as per standard but generally followed

Note: Above table is based on extensive study of popular bus-bar sizes used to terminate Air Circuit Breakers. However other bus-bar sizes (in terms of thickness & width) can also be used to achieve bus-bar cross section recommended by IS & IEC. De-rating of switchgear depends upon various factors such as cross section area, orientation and material of bus bar, healthiness of bus-bar joints, panel construction, and ventilation, etc.

Direct Copper termination

Frame-1 : 400 - 2000A N/S/H

Frame Size	Rating (A)	Copper cross section as per IEC (in sq. mm)	Popular Copper Termination								
			Flat			Horizontal (with Terminal adaptor)			Vertical (with Terminal adaptor)		
			6 mm	10 mm	12 mm	6 mm	10 mm	12 mm	6 mm	10 mm	12 mm
1	800	500	-	60 - 1 run	-	-	50 - 1 run 60 - 1 run	-	-	50 - 1 run 60 - 1 run	-
	1000	600	-	60 - 1 run	-	-	60 - 1 run	-	-	60 - 1 run	-
	1250	800	75 - 2 runs	-	-	75 - 2 runs	-	-	75 - 2 runs	-	-
	1600	1000	60 - 3 runs	-	-	60 - 3 runs	-	-	60 - 3 runs	-	-
	2000	1500	-	-	-	-	75 - 2 runs	-	-	75 - 2 runs	-

Note: Above table is based on extensive study of popular bus-bar sizes used to terminate Air Circuit Breakers. However other bus-bar sizes (in terms of thickness & width) can also be used to achieve bus-bar cross section recommended by IS & IEC. De-rating of switchgear depends upon various factors such as cross section area, orientation and material of bus bar, healthiness of bus-bar joints, panel construction, and ventilation, etc.

All Dimensions in mm

Frame-2 : 400 - 3200A N and 400 - 4000A S/H

Frame Size	Rating (A)	Copper cross section as per IEC (in sq. mm)	Popular Copper Termination					
			Horizontal (with Terminal adaptor)			Vertical (with Terminal adaptor)		
			6 mm	10 mm	12 mm	6 mm	10 mm	12 mm
2	2500	2000	-	100 - 2 runs	-	-	100 - 2 runs	-
	3200	3200 ⁽¹⁾	-	80 - 4 runs	-	-	80 - 4 runs	-
	4000 ⁽²⁾	4000 ⁽¹⁾	-	100 - 4 runs	-	-	100 - 4 runs 150 - 3 runs	-

(1) Not as per standard but generally followed.

(2) Fr-2 4000A recommended for Top Horizontal+Bottom Vertical & Top Vertical+Bottom Vertical configurations only.

Note: Above table is based on extensive study of popular bus-bar sizes used to terminate Air Circuit Breakers. However other bus-bar sizes (in terms of thickness & width) can also be used to achieve bus-bar cross section recommended by IS & IEC. De-rating of switchgear depends upon various factors such as cross section area, orientation and material of bus bar, healthiness of bus-bar joints, panel construction, and ventilation, etc.

Frame-3 : 400 - 6300A H/V

Frame Size	Rating (A)	Copper cross section as per IEC (in sq. mm)	Popular Copper Termination					
			Horizontal (with Terminal adaptor)			Vertical (with Terminal adaptor)		
			6 mm	10 mm	12 mm	6 mm	10 mm	12 mm
3	4000	4000*	160 - 5 run	150 - 3 runs	-	-	125 - 4 runs	-
	5000	6000*	160 - 7 run [#]	150 - 4 runs [#]		-	150 - 4 runs	125 - 4 runs
	6300	7200*	Vertical termination recommended			-	-	150 - 4 runs

*Not as per standard but generally followed

Recommended for Bus coupler application only

Note: Above table is based on extensive study of popular bus-bar sizes used to terminate Air Circuit Breakers. However other bus-bar sizes (in terms of thickness & width) can also be used to achieve bus-bar cross section recommended by IS & IEC. De-rating of switchgear depends upon various factors such as cross section area, orientation and material of bus bar, healthiness of bus-bar joints, panel construction, and ventilation, etc.

Temperature Derating of OMEGA ACBs

Current carrying capacity at different temperatures

Omega Air Circuit Breaker can operate at higher temperatures than the reference temperature of 40°C as prescribed in IS & IEC standards, under certain installation conditions. However in some cases current-carrying capacity needs to be reduced in order to follow temperature rise limits and safe working conditions.

The table below shows the current carrying capacity of U-POWER Omega ACB's where T = temperatures measured around the rear connections of the AIR Circuit Breaker.

Current carrying capacity with copper as bus-bar material & Vertical configuration

Frame size & current rating	Versions	Current carrying capacity at different temperature (T)				
		40° C	50° C	55° C	60° C	70° C
UW1-08	N	800	800	800	800	800
	S	800	800	800	800	800
	H	800	800	800	800	800
UW1-10	N	1000	1000	1000	1000	1000
	S	1000	1000	1000	1000	1000
	H	1000	1000	1000	1000	1000
UW1-12	N	1250	1250	1250	1250	1250
	S	1250	1250	1250	1250	1250
	H	1250	1250	1250	1250	1250
UW1-16	N	1600	1600	1530	1450	1360
	S	1600	1600	1600	1550	1460
	H	1600	1600	1600	1600	1600
UW1-20	N	2000	2000	2000	2000	2000
	S	2000	2000	2000	2000	2000
	H	2000	2000	2000	2000	2000
UW2-25	N/S/H	2500	2500	2500	2500	2500
UW2-32	N/S/H	3200	3200	3200	3200	3050
UW2-40	S/H	4000	4000	4000	3900	3600
UW3-40	H/V	4000	4000	4000	4000	3850
UW3-50	H/V	5000	5000	5000	5000	4770
UW3-63	H/V	6300	6130	5840	5540	5230

Please refer to Pages 127-129 to get the corresponding bus-bar cross section area required with different current rating of Air Circuit Breaker.

Note: The values indicated in the above tables are for general guideline for product selection. These values have been extrapolated from test data and theoretical calculations. They cannot replace practical industrial application or a temperature rise test. However de-rating of switchgear depends on others factors such as cross section area, orientation and material of bus-bar, healthiness of bus-bar joints, panel construction, and ventilation, etc.

Altitude derating of OMEGA ACBs

As altitude rise from sea level, the density of that air reduces dramatically. Reduced air density at altitudes greater than 2000 meters affects the ability of a circuit breaker to transfer heat and interrupt faults compared with sea level. The ability of fault interruption reduces with the increase of altitude because dielectric strength of air also reduces with density.

Altitude derating						
Altitude	H	(m)	<2000	3000	4000	5000
Rated service voltage (at 50/60 Hz)	U_e	(V)	U_e	$0.9U_e$	$0.8U_e$	$0.7U_e$
Rated Uninterrupted Current at 40°C	I_n	(A)	I_n	$0.98I_n$	$0.96I_n$	$0.94I_n$
Impulse withstand voltage	U_{imp}	(kV)	12	11	10	8
Rated insulation voltage	U_i	(V)	1000	900	780	700

Watt-loss Data of OMEGA ACBs

Watt loss plays an important role in the electrical performance of Air Circuit Breaker. Factors like overall dimension, rated current carrying capacity of Bus-bar and watt loss of apparatus attached to the Air Circuit Breaker also plays an important role in calculation of watt loss data.

Total watt loss value is measured at rated current (I_n) of 3 Pole Air Circuit Breaker at 50/60 Hz. ($W=3I_n^2 \times R$), where R is the resistance measured across the upper & lower terminated of ACB.

Frame Size & Current Rating	For draw-out ACB (Watt)			
	N	S	H	V
UW1-08	100	50	35	
UW1-10	160	65	50	
UW1-12	210	100	65	
UW1-16	325	160	100	
UW1-20	440	390	220	
UW2-25	560	560	465	
UW2-32	600	600	600	
UW2-40		770	770	
UW3-40			500	500
UW3-50			750	750
UW3-63			1000	1000

All Dimensions in mm

U-POWER
OMEGA ACB ordering information:
Air Circuit Breakers

UW 1 08 N X D 1 2 9 0 0⁽⁵⁾ (7) | **OMEGA 800A Fr-1 50kA 3P EDO UW-MTX1.5G**

Frame Size	
Frame - 1	1
Frame - 2	2
Frame - 3	3

Current Ratings	
400A	04
630A	06
800A	08
1000A	10
1250A	12
1600A	16
2000A	20
2500A ⁽⁴⁾	25
3200A	32
4000A	40
5000A	50
6300A	63

Selection for Breaking Capacity (Icu=Ics) ⁽¹⁾	
50kA (Fr-1 upto 2000A & Fr-2 upto 3200A)	N
65kA (Fr-1 & Fr-2)	S
80kA (Fr-1, Fr-2 & Fr-3)	H
100kA (Fr-3)	V

Please Note :

- ⁽¹⁾ For Icu values please refer product catalogue
- ⁽²⁾ Other options of control voltage are available as accessory
- ⁽³⁾ Temperature protection is available in UW-MTX3.5/3.5EC/3.5H/4.5

Special Applications	
800V Operational Voltage	M
1000V Operational Voltage	H

Temperature Rise Protection ⁽³⁾	
Not Required	0
Required	1

Selection for P&C Units	
B/C (w/o protection)	0
UW - MTX1.0	7
UW - MTX1G	8
UW - MTX1Gi	B
UW - MTX1.5G	9
UW - MTX1.5Gi	C
UW-MTX3.5	3
UW-MTX3.5EC ⁽⁶⁾	4
UW-MTX3.5H	6
UW-MTX4.5	5

Type	
Manually Operated	1
Electrically Operated	2

Selection for control voltage ⁽²⁾	
For Manually Operated	0
240V AC ECD & CR & 240V AC SR	1
240V AC ECD & CR & 24V DC SR	2

Version	
Draw-out	D
Fixed	F

Selection for No. of Poles	
3 Pole	X
4 Pole 100% N	F
4 Pole 50% N (in Fr-III only)	H
4 Pole 200% N (upto 2500A)	D

- ⁽⁴⁾ For Fr-1, 2500A selection, please contact the nearest branch office
- ⁽⁵⁾ Refer point 'C' of Draw-out Version Omega ACBs
- ⁽⁶⁾ For system requiring 690V metering, kindly order separate Power Metering module with MTX3.5
- ⁽⁷⁾ For Operational Voltage 800V(M-Medium) & 1000V(H-High) requirements 14th digit to be used. For standard Breaker (upto690V) CAT No. configuration remain as it is of 13 digit.

U-POWER
OMEGA ACBs are offered with following standard features:
Air Circuit Breakers

- Draw-out version :** Omega ACBs with UW-MTX release will have inbuilt- Current Metering (MTX1.5G/1.5Gi/3.5/3.5EC/3.5H/4.5), Common Fault Indication microswitch, 4NO+4NC Aux. contacts, Smart-racking shutter, Safety shutter assembly, Racking Handle, Door sealing frame, Pad-locking arrangement for ON/OFF button, Rating Error Preventer & Arc shield (Please contact Sales Office for details about 800V/1000V AC CBs).
- A) For ratings upto 1600A, one side vertical terminal adaptors (Bottom) for Frames 1, 2 & 3.
 - B) For ratings 2000A & above, both side vertical terminal adaptors (Top & Bottom) for Frames 1, 2 & 3.
 - C) For ratings 4000A (Fr2 & Fr3) & 5000A(Fr3) replace 13th digit of ACB cat no with (recommended for Buscoupler only)
 - X : For Top Horizontal (Long) & Bottom Vertical for Fr2 & Fr3
 - Y : For Top & Bottom Horizontal (Long) for Fr3. H-H Termination not recommended for 4000A Fr2.
 - D) For rating 4000A & above, operation counter inbuilt for Frames 2 & 3 both.
- Fixed Version :** Omega ACBs with UW-MTX release will have inbuilt- Current Metering (MTX1.5G/1.5Gi/3.5/3.5EC/3.5H/4.5), Common Fault Indication microswitch, 4NO+4NC Aux. contacts, Door sealing frame & Pad-locking arrangement for ON/OFF push button.
- A) For ratings upto 1600A, one side vertical terminal adaptors (Bottom) for Frames 1, 2 & 3.
 - B) For ratings 2000A & above, both side vertical terminal adaptors (Top & Bottom) for Frames 1, 2 & 3.
 - C) For ratings 4000A & above, operation counter inbuilt for Frames 2 & 3 both.
- Electrically operated ACB includes ECD (240V AC), CR (240V AC) & SR (240V AC OR 24V DC).

Get the Switchgear Training Edge!

Aimed at maximizing productivity, conserving energy, minimizing costs and enhancing safety, our Electrical & Automation training programmes have benefitted over 2.25 Lakh professionals in the last 32 years. These training programmes are highly beneficial as they provide right exposure and impart knowledge on selection, installation, maintenance and testing of Electrical & Automation Products.

So gain the advantage and go the extra mile with:

- 14 courses on contemporary topics
- Courses applicable to all switchgear brands
- Training Centers in Pune, Lucknow, Coonoor, Vadodara, Delhi & Kolkata
- Blend of theory and practical experience

The typical training programmes cover:

- Low Voltage & Medium Voltage Switchgear
- Switchboard Electrical Design
- AC Drives & Building Management Solutions
- Protective Relays, Earthing, Reactive Power Management & Harmonics
- Energy Conservation & Management

Please contact any of the training centres for participation and detailed training programme schedule.



Pune

L&T Electrical & Automation
Switchgear Training Centre,
T-156/157, MIDC
Bhosari, Pune - 411 026
Tel: 020 2712 0037 / 2712 0653
Fax: 020 2712 2933
E-mail: stc-pune@Lntebg.com



Lucknow

L&T Electrical & Automation
Switchgear Training Centre,
C - 6 & 7, UPSIDC
P. O. Sarojinagar, Lucknow - 226 008
Tel: 0522 247 6015 / 97944 54455
Fax: 0522 247 6015
E-mail: stc-lucknow@Lntebg.com



Coonoor

L&T Electrical & Automation
Switchgear Training Centre,
Ooty-Coonoor Main Road
Yellanahalli P.O., The Nilgiris - 643 243
Tel. : 0423 251 7107
Fax : 0423 251 7158
E-mail: stc-coonoor@Lntebg.com



Vadodara

L&T Electrical & Automation
Switchgear Training Centre
Behind L&T Knowledge City,
Near Village Ankhola,
Vadodara - 390019
Tel: 0265 2457805
E-mail: stc-vadodara@Lntebg.com



Delhi

L&T Electrical & Automation
Switchgear Training Centre
32, Shivaji Marg,
Near Motinagar Metro Station,
New Delhi - 110015
Tel: 011 41419515 / 41419695 / 41419500
Fax: 011 41419600
E-mail: stc-delhi@Lntebg.com

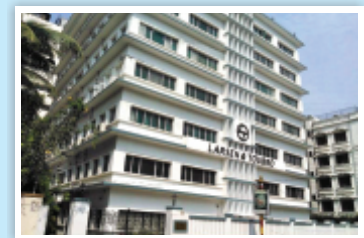

Kolkata

L&T Electrical & Automation
Switchgear Training Centre
4th Floor, 3B, Shakespeare Sarani,
Kolkata - 700071
Tel: 033 42005975 / 42005978
E-mail: stc-kolkata@Lntebg.com

Electrical Standard Products (ESP) Offices:

HEAD OFFICE

L&T Electrical & Automation
L&T Business Park, TC 2, Tower 'B'
3rd Floor, Gate No 5
Saki Vihar Road, Powai
Mumbai 400 072
Tel: 022-67052874 / 2737 / 1156
e-mail: cic@LNTEBG.com

BRANCH OFFICES

L&T Electrical & Automation
501, Sakar Complex I
Opp. Gandhigram Rly. Station
Ashram Road
Ahmedabad 380 009
Tel: 079 4900 4000/4001
e-mail: esp-ahm@LNTEBG.com

L&T Electrical & Automation
No 38, Cubbon Road
Bengaluru 560 001
Tel: 080-46136103 / 100
e-mail: esp-blr@LNTEBG.com

L&T Electrical & Automation
131/1, Zone II, Maharana Pratap Nagar
Bhopal 462 011
e-mail: esp-bho@LNTEBG.com

L&T Electrical & Automation
Plot No. 559, Annapurna Complex
Lewis Road
Bhubaneswar 751 014
Tel: 0674-2436690 / 2436696
e-mail: esp-bsr@LNTEBG.com

L&T Electrical & Automation
Aspire Towers, 4th Floor
Plot No. 55, Phase-I
Industrial & Business Park
Chandigarh 160 002
Tel: 0172-4646840 / 41 / 42 / 46 / 53
e-mail: esp-chd@LNTEBG.com

L&T Electrical & Automation
L&T Construction Campus
TC-1 Building, II Floor
Mount-Poonamallee Road
Manapakkam
Chennai 600 089
Tel: 044-2270 6800
e-mail: esp-maa1@LNTEBG.com

L&T Electrical & Automation
67, Appuswamy Road, Post Bag 7156
Opp. Nirmala College
Coimbatore 641 045
Tel: 0422-4588120 / 1 / 5
e-mail: esp-cbe@LNTEBG.com

L&T Electrical & Automation
3rd Floor, 1&2 Vijay Park,
Main Chakrata road
Ballapur Chowk
Dehradun 248001
Tel: +91 9582252411

L&T Electrical & Automation
Khairasol, Degaul Avenue
Durgapur 713 212
Tel: 0343-2540448 / 2540449 / 2540443
e-mail: esp-dgp@LNTEBG.com

L&T Electrical & Automation
5, Milanpur Road, Bamuni Maidan
Guwahati 781 021
Tel: +91 8876554417
e-mail: esp-ghy@LNTEBG.com

L&T Electrical & Automation
2nd Floor, Vasantha Chambers
5-10-173, Fateh Maidan Road
Hyderabad 500 004
Tel: 040-67015052
e-mail: esp-hyd@LNTEBG.com

L&T Electrical & Automation
Monarch Building, 1st Floor
D-236 & 237, Amrapali Marg
Vaishali Nagar
Jaipur 302 021
Tel: 0141-4385914 to 18
e-mail: esp-jai@LNTEBG.com

L&T Electrical & Automation
Akashdeep Plaza, 2nd Floor
P. O. Golmuri
Jamshedpur 831 003
Jharkhand
Tel: 0657-2340502 / 08
e-mail: esp-jam@LNTEBG.com

L&T Electrical & Automation
Skybright Bldg; M. G. Road
Ravipuram Junction, Ernakulam
Kochi 682 016
Tel: 0484-4409420 / 4 / 5 / 7
e-mail: esp-cok@LNTEBG.com

L&T Electrical & Automation
3-B, Shakespeare Sarani
Kolkata 700 071
Tel: 033-48006001
e-mail: esp-ccu@LNTEBG.com

L&T Electrical & Automation
No. 10, Fortuna Tower, 2nd Floor
Rana Pratap Marg, Near NBRI
Lucknow 226001
e-mail: esp-lko@LNTEBG.com

L&T Electrical & Automation
No: 73, Karpaga Nagar, 8th Street
K. Pudur
Madurai 625007
Tel: 0452-2567405 / 2561068 / 2561657
e-mail: esp-mdu@LNTEBG.com

L&T Electrical & Automation
L&T Business Park, TC 2, Tower 'B'
3rd Floor, Gate No 5
Saki Vihar Road, Powai
Mumbai 400 072
Tel: 022-67052874 / 2737 / 1156
e-mail: esp-bom@LNTEBG.com

L&T Electrical & Automation
Unnati Building, 2nd Floor
Automation Campus
A-600, TTC Industrial area
Shil-Mahape road, Mahape
Navi Mumbai 400710
Tel: +91 22 67226502 / 67226300

L&T Electrical & Automation
12, Shivaji Nagar
North Ambajhari Road
Nagpur 440 010
Tel: 0712-2260012 / 6606421
e-mail: esp-nag@LNTEBG.com

L&T Electrical & Automation
32, Shivaji Marg,
Near Moti Nagar,
P. O. Box 6223
New Delhi 110 015
Tel: 011-41419514 / 5 / 6
e-mail: esp-del@LNTEBG.com

L&T Electrical & Automation
Grand Chandra, 2nd Floor
Fraser Road
Opposite Doordarshan Kendra
Patna 800001
e-mail: esp-patna@LNTEBG.com

L&T Electrical & Automation
L&T House
P. O. Box 119
191/1, Dhole Patil Road
Pune 411 001
Tel: 020-48544395 / 48544279
e-mail: esp.pnq@LNTEBG.com

L&T Electrical & Automation
Crystal Tower,
4th Floor, G. E. Road
Telibandha
Raipur 492 006
Tel: 0771-4283214
e-mail: esp-raipur@LNTEBG.com

L&T Electrical & Automation
3rd Floor
Vishwakarma Chambers
Majura Gate, Ring Road
Surat 395 002
Tel: 0261-2473726
e-mail: esp-sur@LNTEBG.com

L&T Electrical & Automation
Radhadaya Complex
Old Padra Road
Near Charotar Society
Vadodara 390 007
Tel: 0265-6613610 / 1 / 2
e-mail: esp-bar@LNTEBG.com

L&T Electrical & Automation
Door No. 49-38-14/3/2, 1st floor,
NGGO's Colony, Akkayyapalem,
Visakhapatnam 530 016
Tel: 0891-2791126 / 2711125
e-mail: esp-viz@LNTEBG.com

Product improvement is a continuous process. For the latest information and special application, please contact any of our offices listed here. Product photographs shown for representative purpose only.



L&T Electrical & Automation, Electrical Standard Products

L&T Business Park, TC-2, Tower B, 3rd Floor, Gate No. 5, Saki Vihar Road, Powai,
Mumbai - 400 072, INDIA www.Lntebg.com

Customer Interaction Center (CIC)

BSNL / MTNL (toll-free): 1800 233 5858 Reliance (toll-free): 1800 200 5858
Tel: 022 6774 5858 Email: cic@Lntebg.com Web: www.Lntebg.com