

# DU / DY Range of Moulded Case Circuit Breakers

A Journey of Continuous Upgradation



UTILITY



DG SET



BUILDING

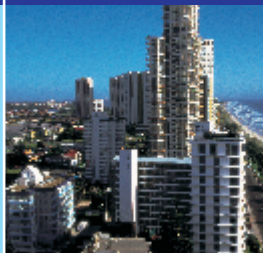

UPS



BATTERY BANKS



CAPACITOR



## ABOUT US

L&T Electrical & Automation (E&A) is a market leader for electrical distribution, monitoring and control solutions in the low voltage category.

Popular among customers as L&T Switchgear, E&A offers a wide range of low and medium voltage switchgear, motor starters, electrical systems, industrial automation, building electrical solutions, energy management solutions, electrical modernization solutions and metering solutions. Its products and solutions cater to key sectors of economy like industries, utilities, infrastructure, building and agriculture.

E&A's manufacturing operations at Navi Mumbai, Ahmednagar, Vadodara, Coimbatore and Mysuru in India adhere to global practices of excellence and receive support from well-equipped in-house design and development centres as well as tooling facilities that contribute to precision in manufacturing.



Switchgear Factory, Vadodara

# INDEX

Description	Page No.
Introduction .....	1
MCCB Enclosure .....	1
Salient Features .....	2
Technical Specifications .....	3
I-T Characteristic Curves .....	5
Dimensions .....	6
Ground Fault Module .....	15

**NEW**





# INTRODUCTION

The DU/DY Series, a new generation of MCCBs, stands out due to its state-of-the-art design, contemporary user-friendly features, ergonomics, aesthetics and compactness.

DU/DY Series complies with the latest standards like IS/IEC 60947-2, IEC 60947-2 & EN 60947-2. The products conform to international standards, carry  $\text{C}\epsilon$  marking and are *KEMA* & CB certified.

The range is specially designed for tropical conditions, ensuring reliable performance at high ambient and humid environments. The range can satisfy the most demanding system requirements.

The DU/DY Series, having a wide range of accessories, ensures operational safety, reliability and versatility.

## MCCB ENCLOSURE

New Range of MCCB enclosures, Size I Enclosure suitable for DU100D/DU125D/DU100H/DU125H/DY125U and Size II Enclosure suitable for DU250/DU250C. These standalone enclosures not only provides ample space for cable termination but are also superior in aesthetics.

- Conforms to IEC 62208, IEC 62262 and IEC 60529
- Common Enclosure for 3P/4P MCCBs
- RoHS compliant
- IP30 Protection & IK08 Protection
- Inbuilt Neutral Link for TPN systems
- Mounting Holes on the back plate
- Louvers for better heat dissipation

Enclosure	Height (mm)	Width (mm)	Depth (mm)
Size I	543	198	97
Size II	830	337	111



Size I Enclosure

Size II Enclosure

Separate cable gland box NOT required

Common Enclosure for 3P & 4P MCCBs

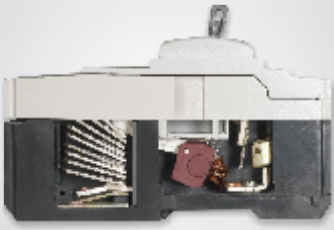

## Technology

- Current Limiting MCCBs: The unique speed contact system with current limiting feature accelerates the opening of contacts during short circuit, resulting in very low let-through energy
- No load line bias: Either side of MCCB terminal can be used as load or line
- MCCB Mechanism: Quick make, quick break & trip free mechanism



## Ergonomic Design & User Friendliness

- Knob designed for better grip
- Color indication of ON/TRIP/OFF
- Current rating on the knob\*
- Overload adjustment from front\*
- Easy ON/OFF/RESET operations



## Safe to Use

- Suitable for Isolation
- Finger proof terminals
- Phase barriers supplied along with MCCBs to enhance the clearance between the phases
- Lockable shroud on thermal knob to prevent unauthorized operation\*
- CE marked range
- Double Insulation



## Accessories

- Auxiliary contacts
- Trip alarm contacts
- Combined Auxiliary + Trip alarm contacts\*
- Shunt release
- Under Voltage release\*
- Direct & Extended ROM with Padlocking
- Spreader links
- Size I & Size II Enclosure
- GF module for earth fault protection\*
- All internal accessories are Snap fit type



## Compact & Easy to Install

- Compact size
- Common depth upto 250A
- 46mm door cutout upto 250A

\* For DU100D / DU125D / DU100H / DU125H / DU250C / DU250 / DU400N

DY Series

NEW

Technical Parameters		Specifications
<b>Type Designation</b>		<b>DY125U</b>
No. of Poles		2/3/4
Rated Current	$I_n$ (A)	16, 20, 25, 32, 40, 50, 63, 80, 100, 125
Impulse Withstand Voltage	$U_{mp}$ (kV)	8
Rated Operational Voltage	$U_o$ (V AC)	415
	$U_o$ (V DC)	250
Rated Insulation Voltage	$U_i$ (V AC)	800
Operational Frequency (Hz)		50 / 60
Utilisation Category		A
Reference Temperature		40 °C
Operating Temperature		-5 °C to + 55 °C
Standard		IS60947-2, IEC60947-2 & EN60947-2
$I_{cu}$ (kA)	240 V AC	25
	415 V AC	10
	250 V DC <sup>#</sup>	10
Rated Service S. C. Breaking Capacity ( $I_{cs}$ )		100% of $I_{cu}$
Mechanical Life	No. of operations	30000
Electrical Life	No. of operations	8000 <sup>§</sup>
IP Protection (from front side)		IP40
Pollution Degree		III
<b>Type of Release</b>		<b>Thermal - Magnetic</b>
Thermal		Fixed
Magnetic		Fixed ( $10I_n$ )*
<b>Terminal Capacity (without spreaders)</b>		
Cables with Lug (mm <sup>2</sup> )		50
Link (mm)		≤17
<b>Overall Dimensions</b>		
Width (3/4 Pole) (mm)		75/100
Height (mm)		130
Depth (mm)		60
Weight (2/3/4 Pole) (kg)		0.60 / 0.67 / 0.92

Note: 2 Pole in 3 Pole frame size

§ 5000 for 125 A

\* 320A for 16A, 20A, 25A

# Any 2 poles can be used. One for "+" polarity &amp; other for "-" polarity.

## DU Series

Technical Parameters		Specifications				
Type Designation		DU100D/DU125D	DU100H/DU125H	DU250C	DU250	DU400N
No. of Poles		3/4	2/3/4	3/4	2/3/4	2/3/4
Rated Current	$I_n$ (A)	20, 25, 32, 40, 50, 63, 80, 100, 125	20, 25, 32, 40, 50, 63, 80, 100, 125	160, 200, 250		320, 400
Impulse Withstand Voltage	$U_{imp}$ (kV)	8				8
Rated Operational Voltage	$U_e$ (V AC)	415				690
Rated Insulation Voltage	$U_i$ (V AC)	800				800
Operational Frequency (Hz)		50 / 60				
Utilisation Category		A				
Reference Temperature		40 °C				
Operating Temperature		-5 °C to + 55 °C				
Standard		IS/IEC60947-2, IEC60947-2 & EN60947-2				
$I_{cu}$ (kA)	240 V AC	32	65	65	65	65
	415 V AC	18	30	25	36	50
	250 V DC (2P in series) L/R<15 msec	-	15	-	15	25
	250 V DC (3P in series) L/R<15 msec	15	20	15	20	30
	500 V DC (3P in series) L/R<15 msec	10	15**	10	15**	20***
Rated Service S. C. Breaking Capacity ( $I_{cs}$ )		100% of $I_{cu}$	50% of $I_{cu}$			
Single Stage Capacitor Rating at 415V, 50Hz (kVAR)		upto 50 kVAR* (for 100A) & 65 kVAR* (for 125A)		upto 95 kVAR*		upto 150 kVAR*
Mechanical Life	No. of operations	40000		15000		10000
Electrical Life	No. of operations	8000 <sup>§</sup>		5000 <sup>§</sup>		4000
IP Protection (from front side)		IP40				
Pollution Degree		III				
Type of Release		Thermal - Magnetic				
Thermal		Variable (0.8 - 1.0 $I_n$ )				
Magnetic		Fixed (9 $I_n$ )				
Terminal Capacity (without spreaders)						
Cables with Lug (mm <sup>2</sup> )		35		120		185
Link (mm)		≤17		≤26		≤32
Overall Dimensions						
Width (mm)		75/100	75/75/100	105/140		140/184
Height (mm)		130		165		205
Depth (mm)		60		60		110.5
Weight (2/3/4 Pole) (kg)		0.85/1.1	0.6/0.85/1.1	1.55/2	1.3/1.55/2	4/5

\* Please use Capacitor Duty Contactors with MCCB for Capacitor Applications. Capacitor ratings mentioned are with MO C only.

\*\* 10 kA at 500V d.c. (2P in series) L/R<15 msec

\*\*\* 15kA at 500V d.c. (2P in series) L/R<15 msec

§ 4000 for DU125D/DU125H, 3000 for 250A DU250/DU250C

Note : 2P MCCBs are available upto 100A in DU100H

DY125U

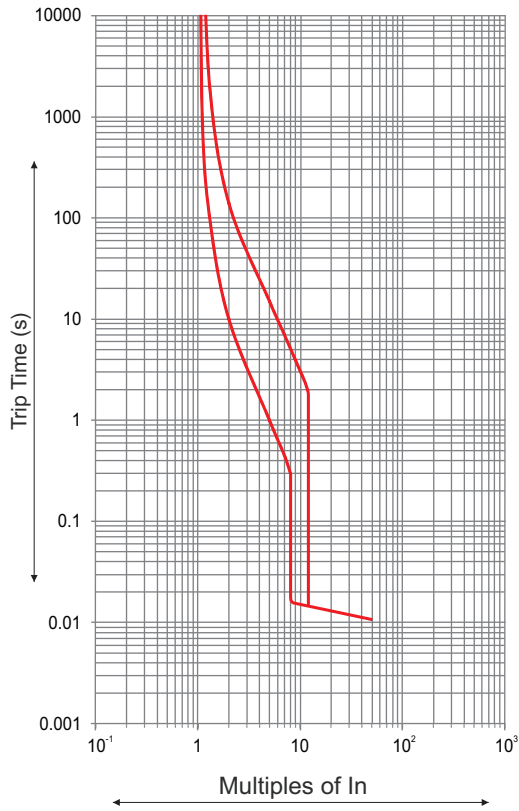

DU100D / DU125D / DU100H / DU125H

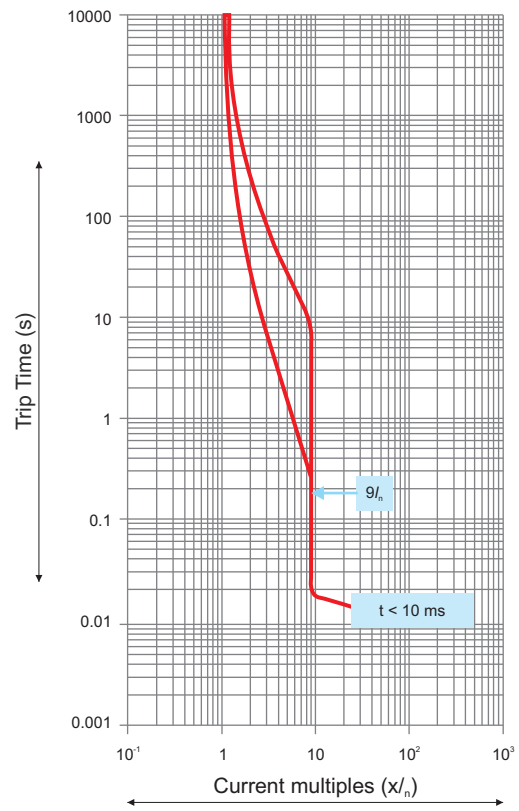

DU250C / DU250

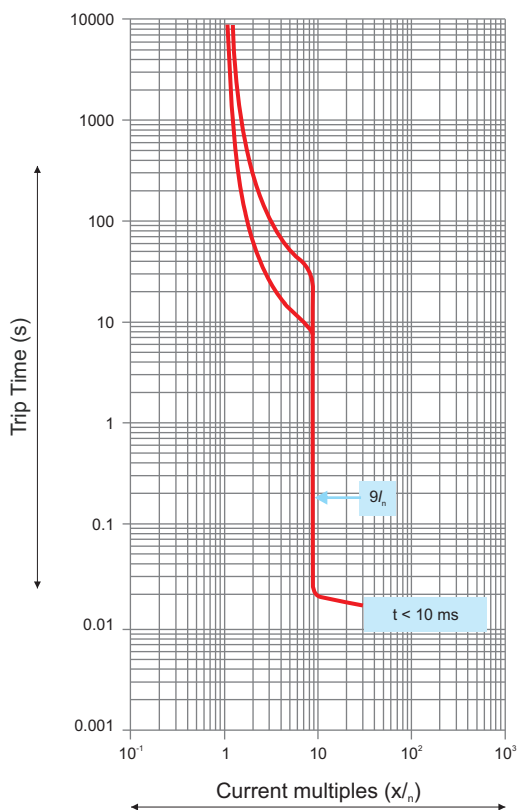

DU400N

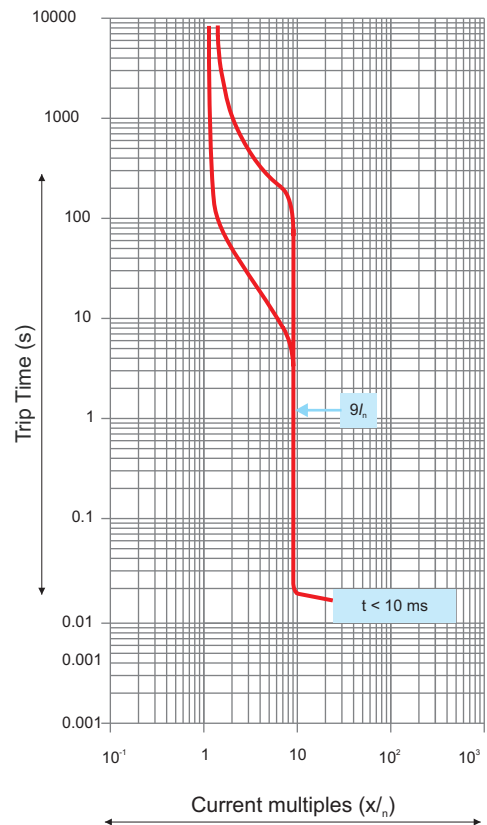

Note : All Curves are  $I_r$  (rated current) based till overload zone.



## DY125U

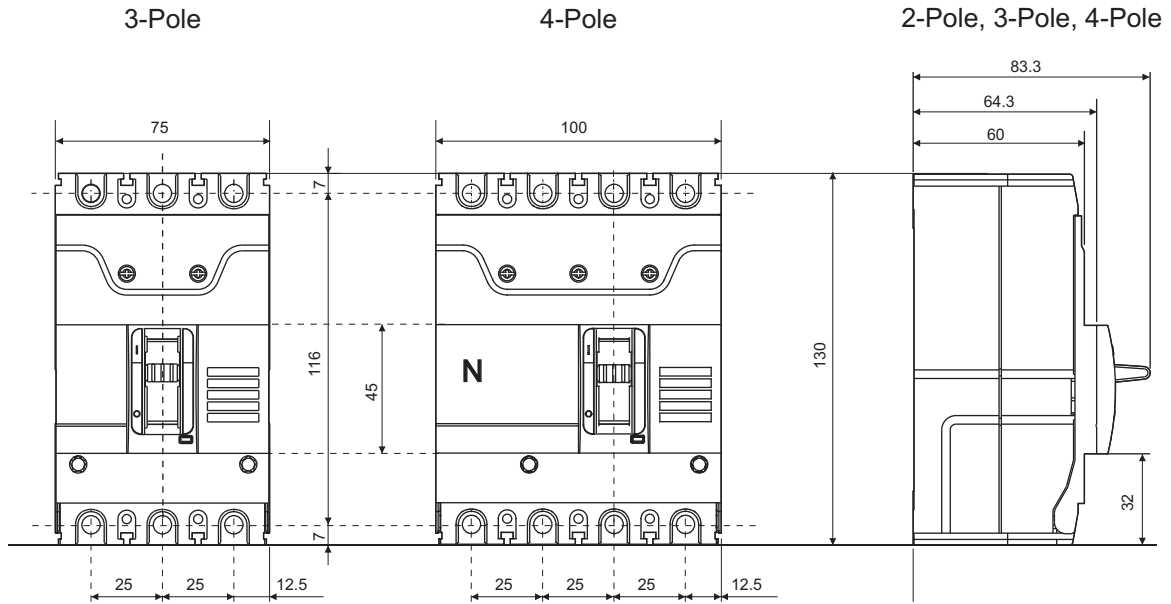

## DY125U With Spreader

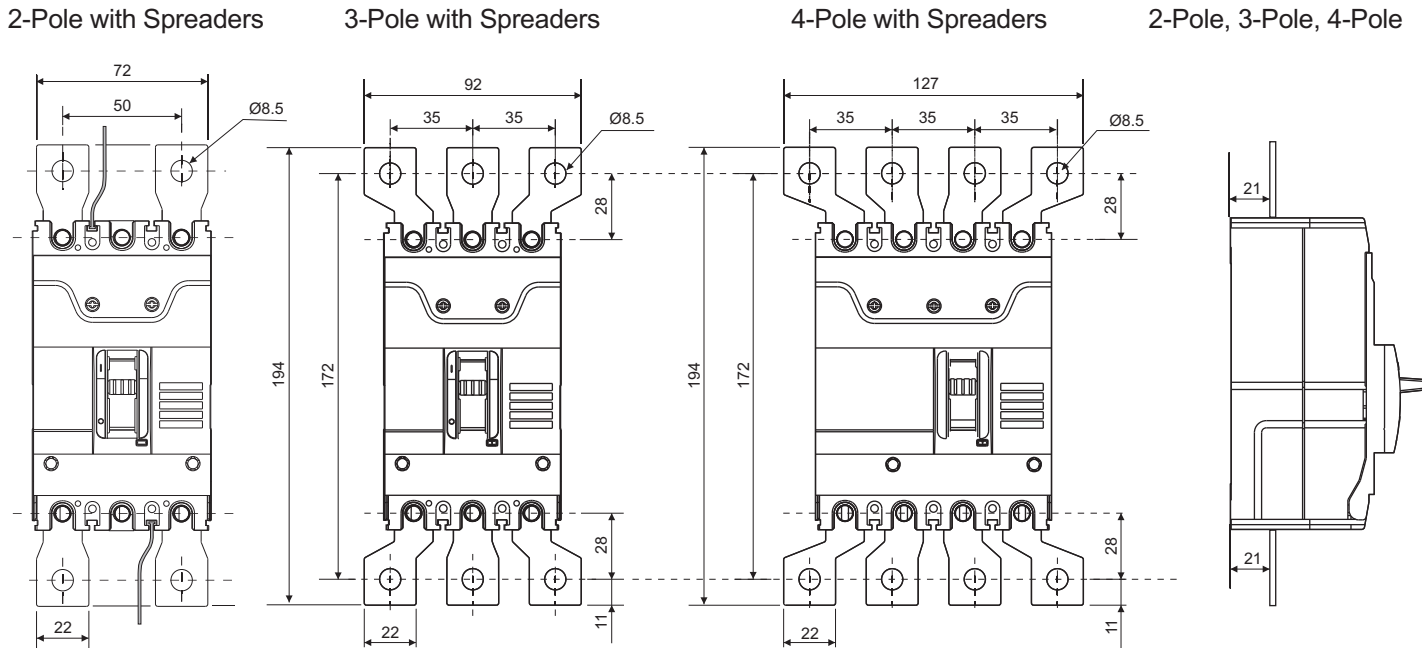

Link width (without spreader) :  $\leq 17\text{mm}$   
 Link width (with spreader) :  $25\text{mm}$

**Note:** Spreader links are available as spare.  
 It is recommended to use spreader links for enhancing termination capacity.  
 Please use 125A MCCB with its recommended Spreader only.

## DU100D / DU125D / DU100H / DU125H

2-Pole

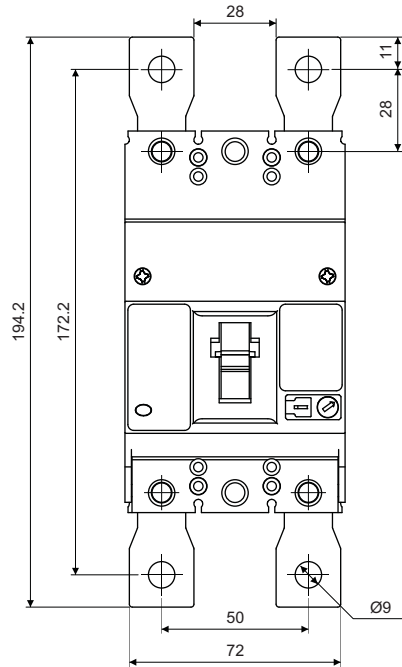

3-Pole, 4-Pole

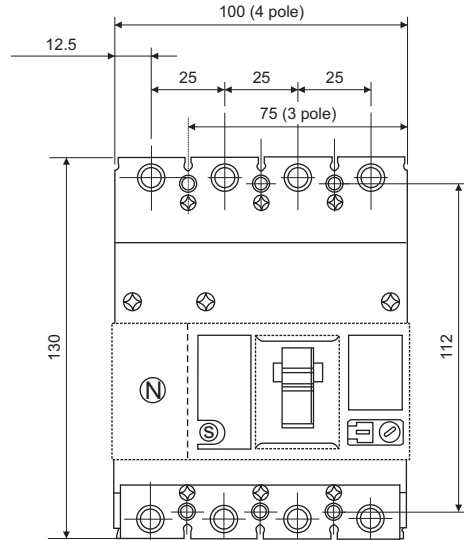

3-Pole with Spreaders

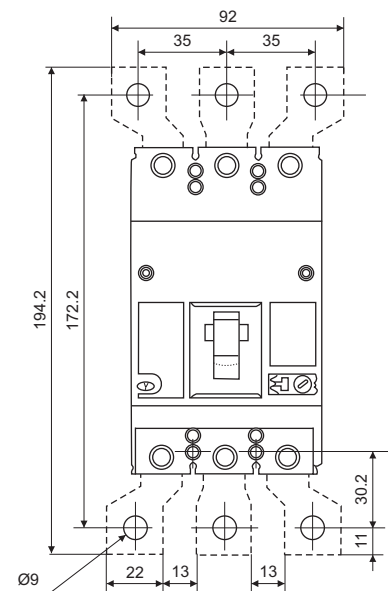

4-Pole with Spreaders

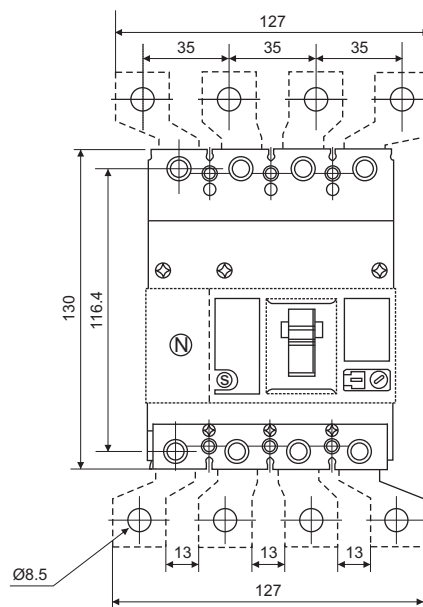

2-Pole, 3-Pole, 4-Pole

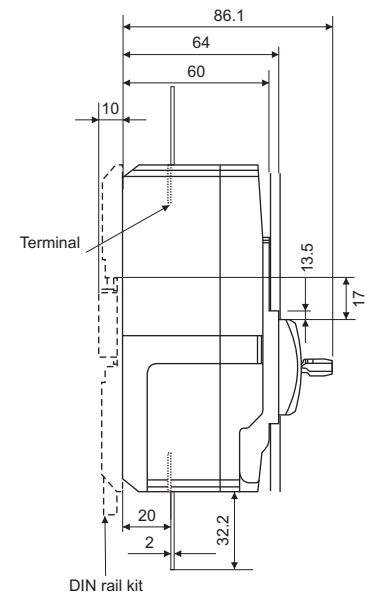

Link width (without spreader) :  $\leq 17$ mm  
 Link width (with spreader) : 22mm

**Note:** Spreader links are available as spare.

It is recommended to use spreader links for enhancing termination capacity.  
 Please use 125A MCCB with its recommended Spreader only.

## DU250C / DU250

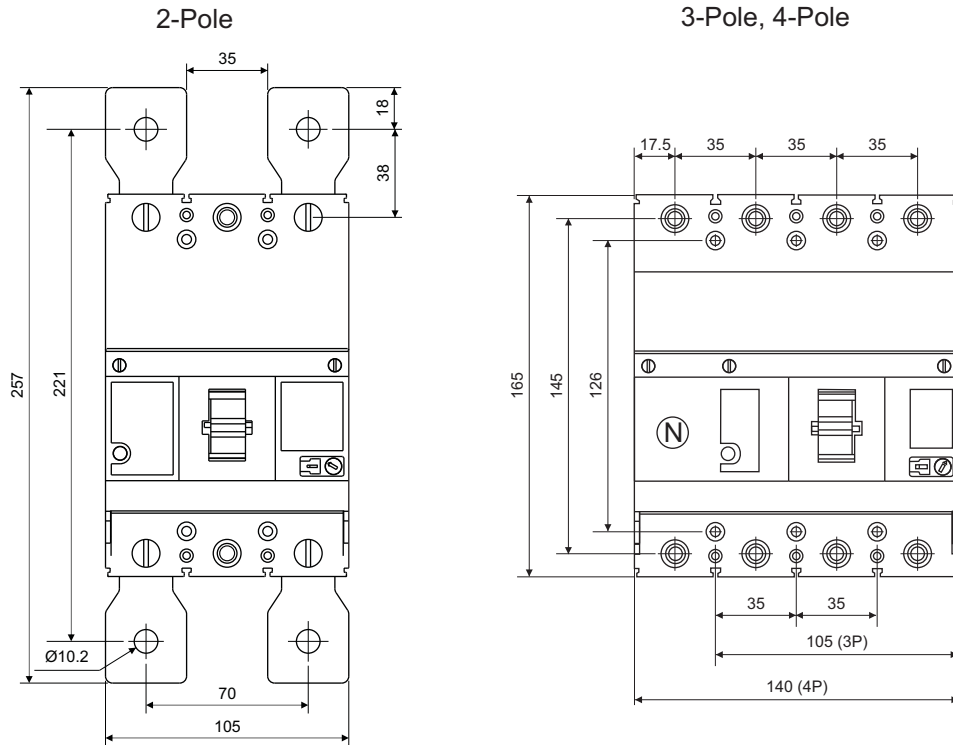

3-Pole with Spreaders

4-Pole with Spreaders

2-Pole, 3-Pole, 4-Pole

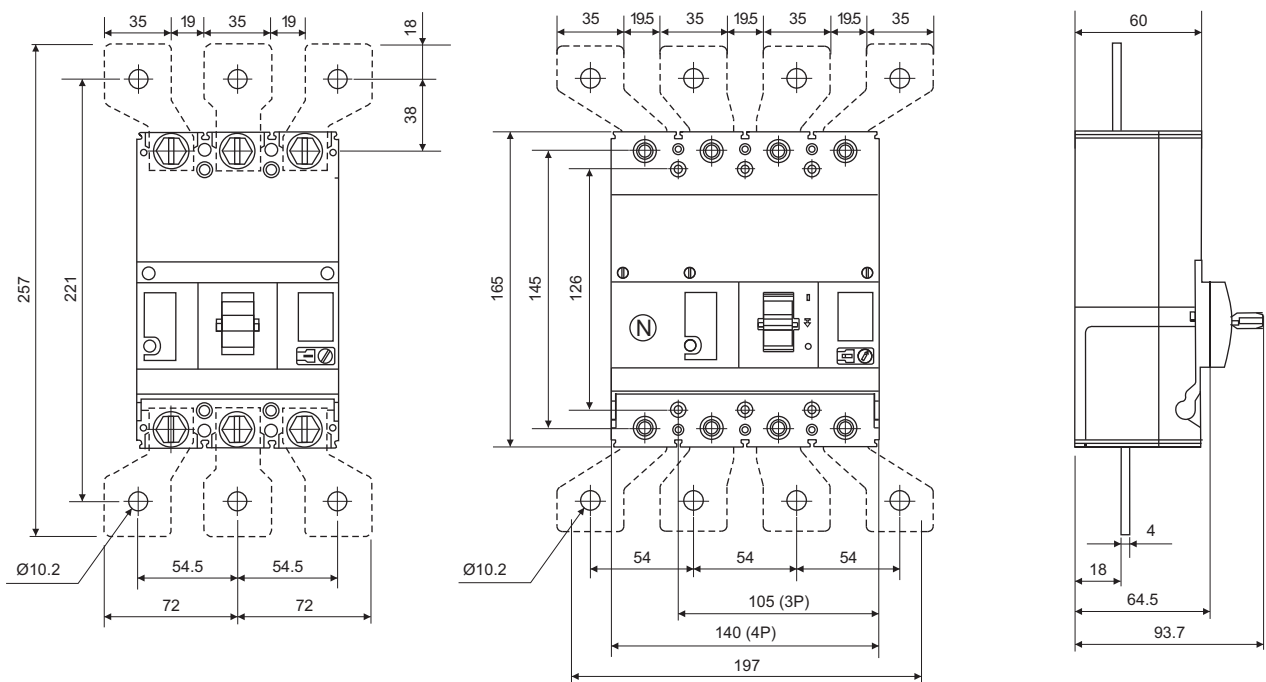

Link width (without spreader) :  $\leq 26$  mm  
 Link width (with spreader) : 35 mm

**Note:** Spreader links are available as spare. It is recommended to use spreader links for enhancing termination capacity.

## DU400N

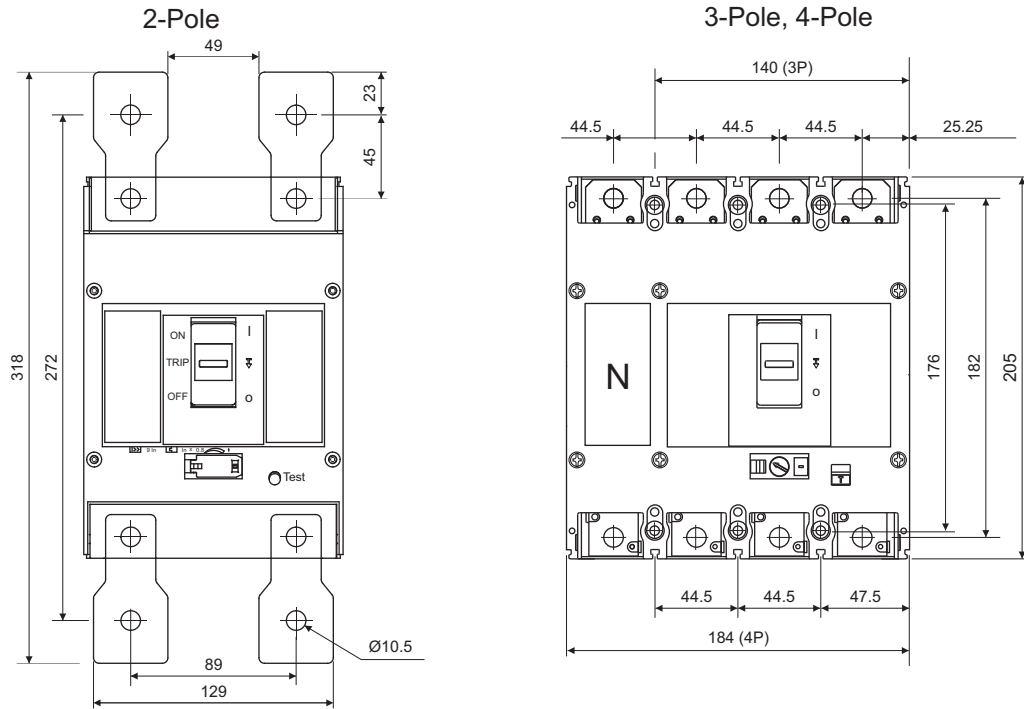

3-Pole with Spreaders

4-Pole with Spreaders

2-Pole, 3-Pole, 4-Pole

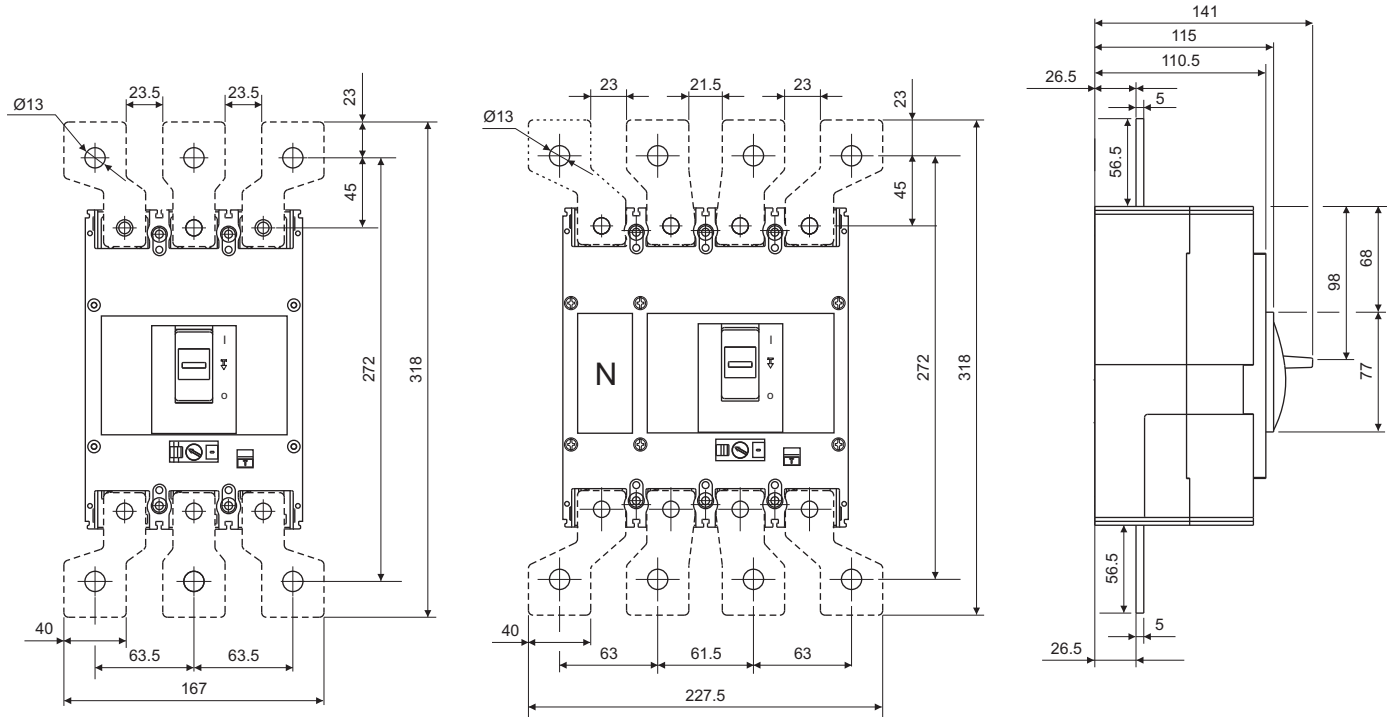

Link width (without spreader) :  $\leq 32$  mm  
 Link width (with spreader) : 40 mm

**Note:** Spreaders are available as spare. It is recommended to use spreader links for enhancing termination capacity.

## DY125U

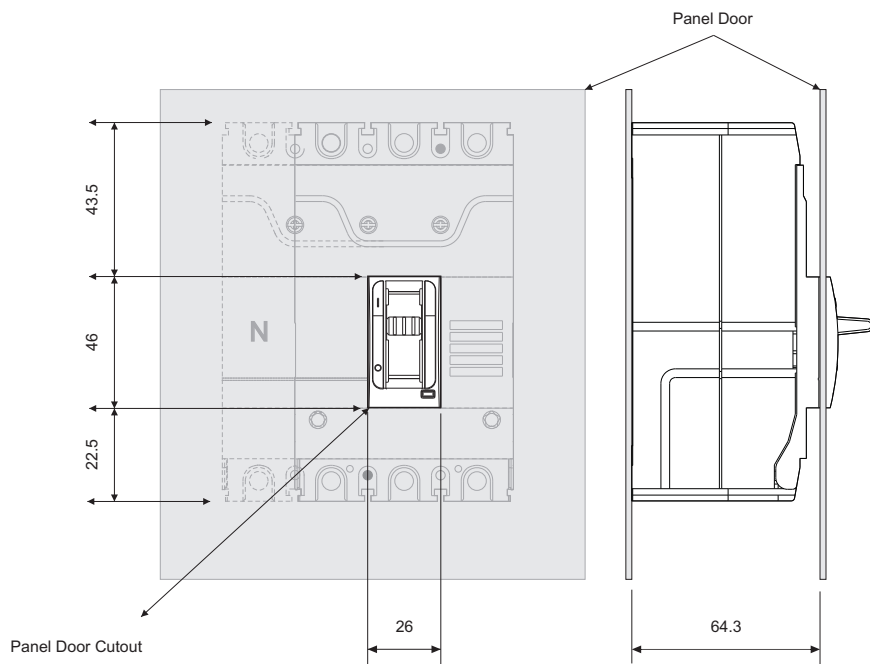
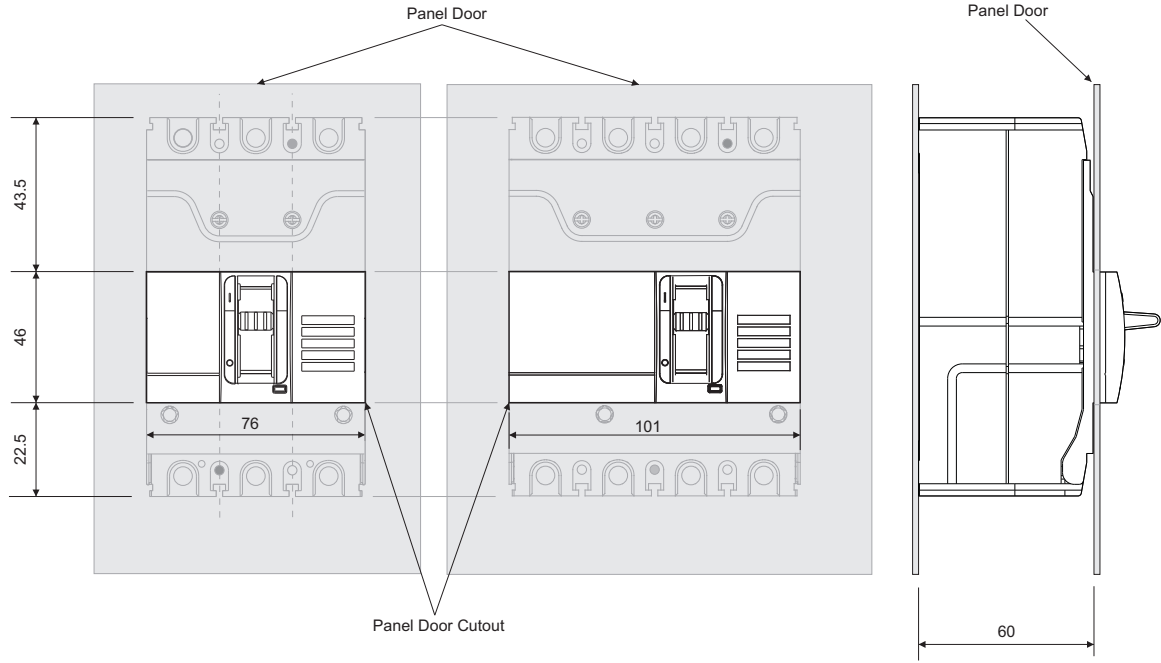



## DU100D / DU125D / DU100H / DU125H

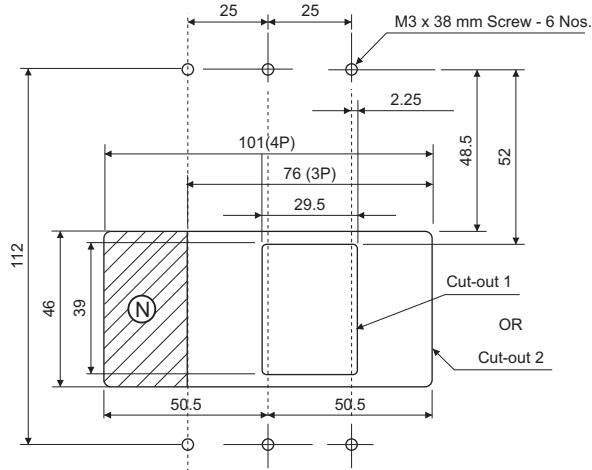

## DU250C / DU250

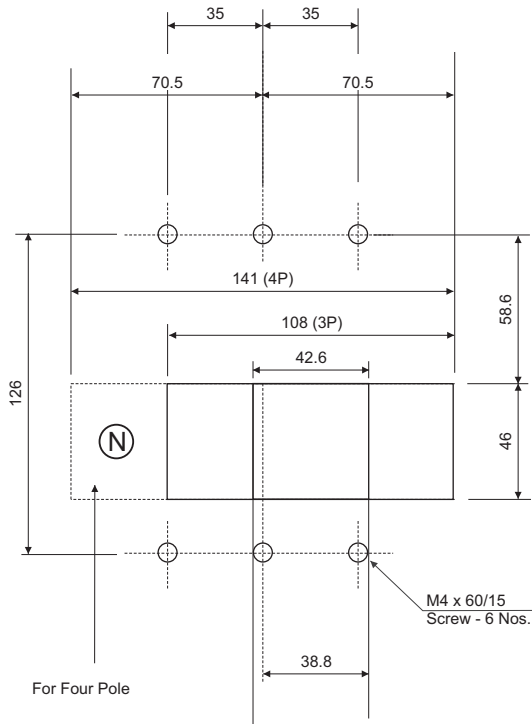

## DU400N

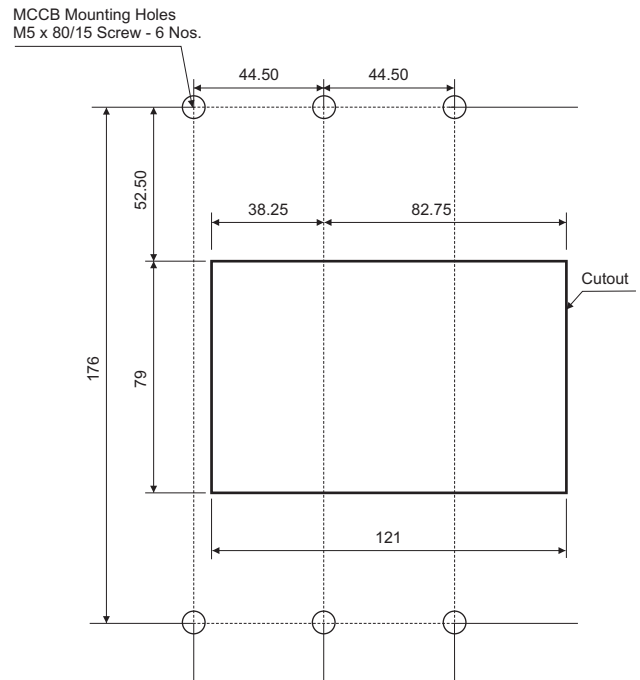

## Direct ROM (DY125U)

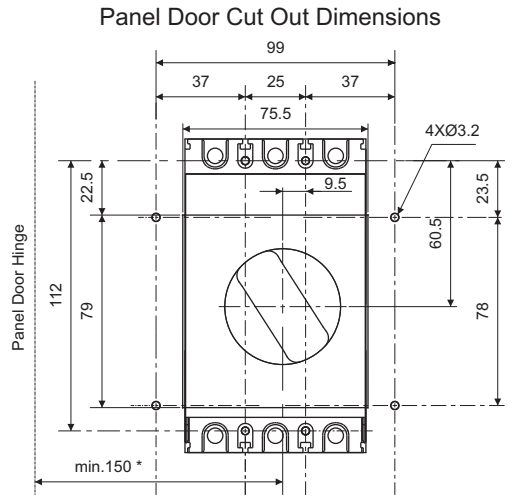
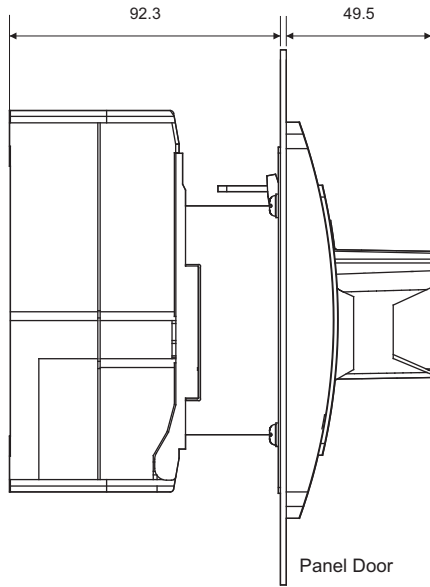

\* Minimum hinge radius for Horizontal/Vertical MCCB installation

## Extended ROM (DY125U)

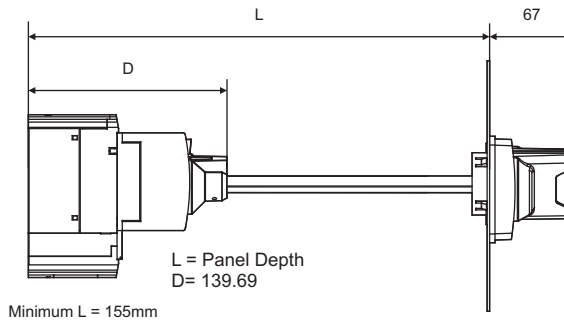

Vertical & Horizontal References with Regards to MCCB Mounting

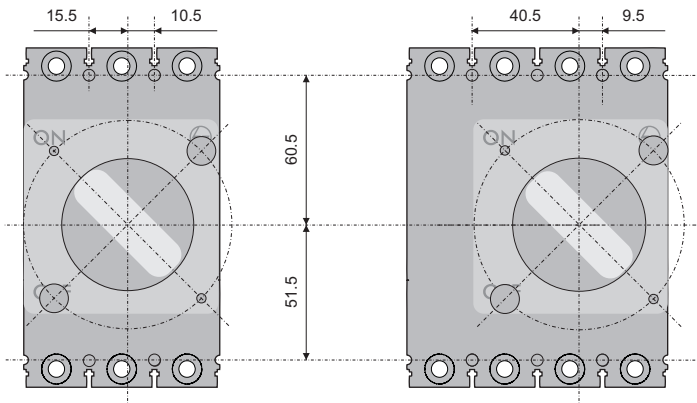

Panel Cut Details as Viewed From the Front

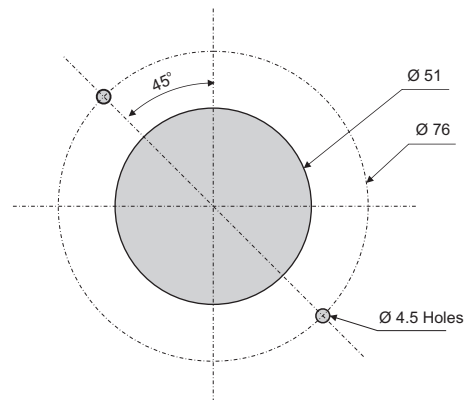

All dimensions are in mm

## Direct ROM (DU100D / DU125D / DU100H / DU125H / DU250C / DU250 / DU400N)

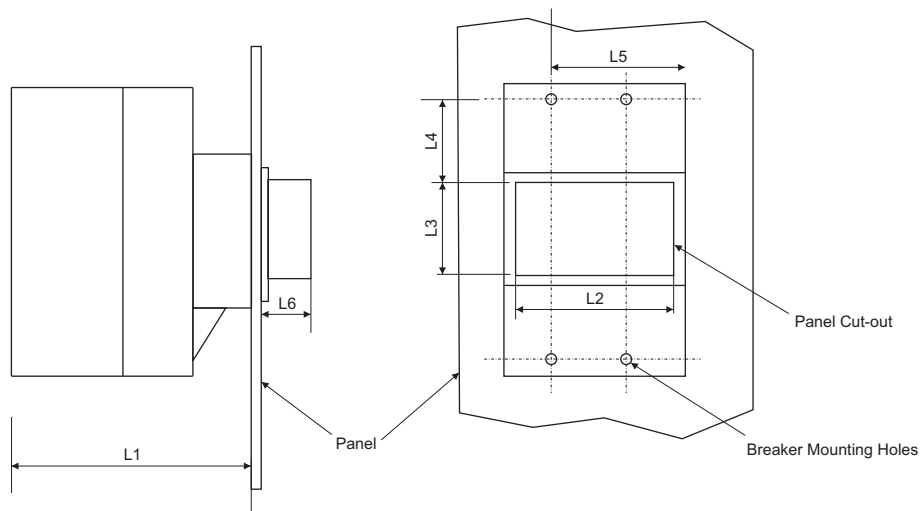

Type	L1	L2	L3	L4	L5	L6
DU100D/DU125D/DU100H/DU125H	96.5	58	52	43.5	37	85
DU250C/DU250	96.5	73	52	56.5	54	77
DU400N	145	121	87	41	82	95

L1 = Mounting Depth  
 L2/L3 = Panel Cut-out  
 L4/L5 = Breaker Mounting Reference  
 L6 = Depth outside the panel

Note : For DU100/DU125U/DU100B Direct ROM dimensions please refer product insert

## Extended ROM (DU100D / DU125D / DU100H / DU125H / DU250C / DU250 / DU400)

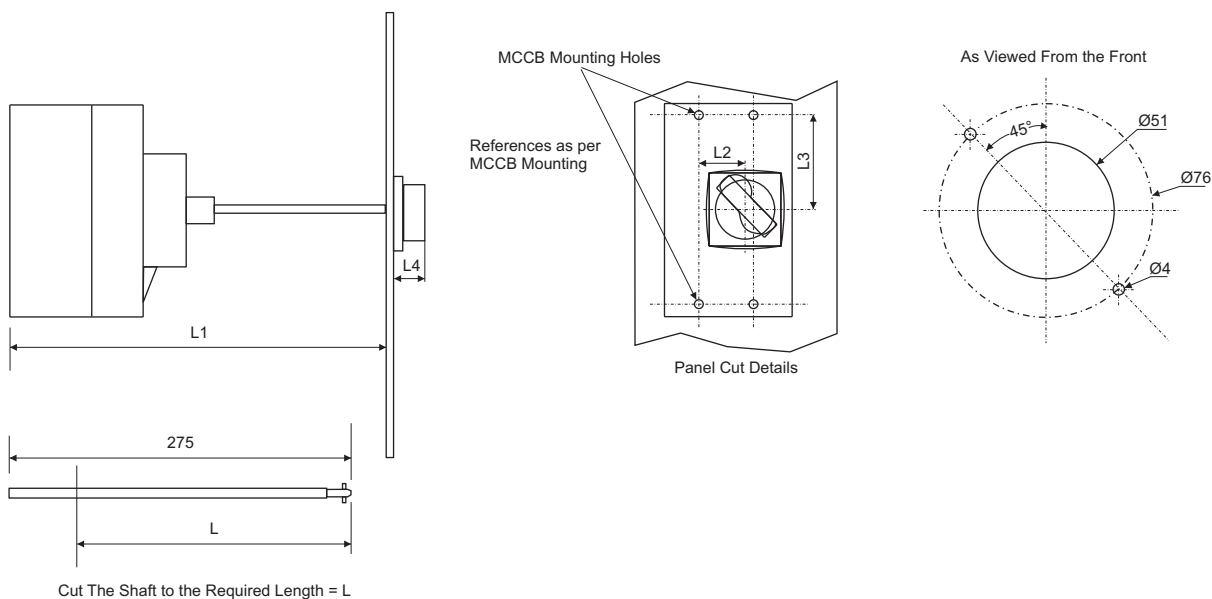

Type	L1	L	L2	L3
DU100D/DU125D/DU100H/DU125H	169	L1-119	7.5	69.5
DU250C/DU250	169	L1-119	24.5	81.7
DU400N	233	L1-183	39	93

L = Length of Shaft required for Panel Depth L1 (mm)  
 L1 = Min. Panel depth (mm)  
 L4 = Depth outside the panel

## Size I Enclosure for DU100D/DU125D/DU100H/DU125H/DY125U

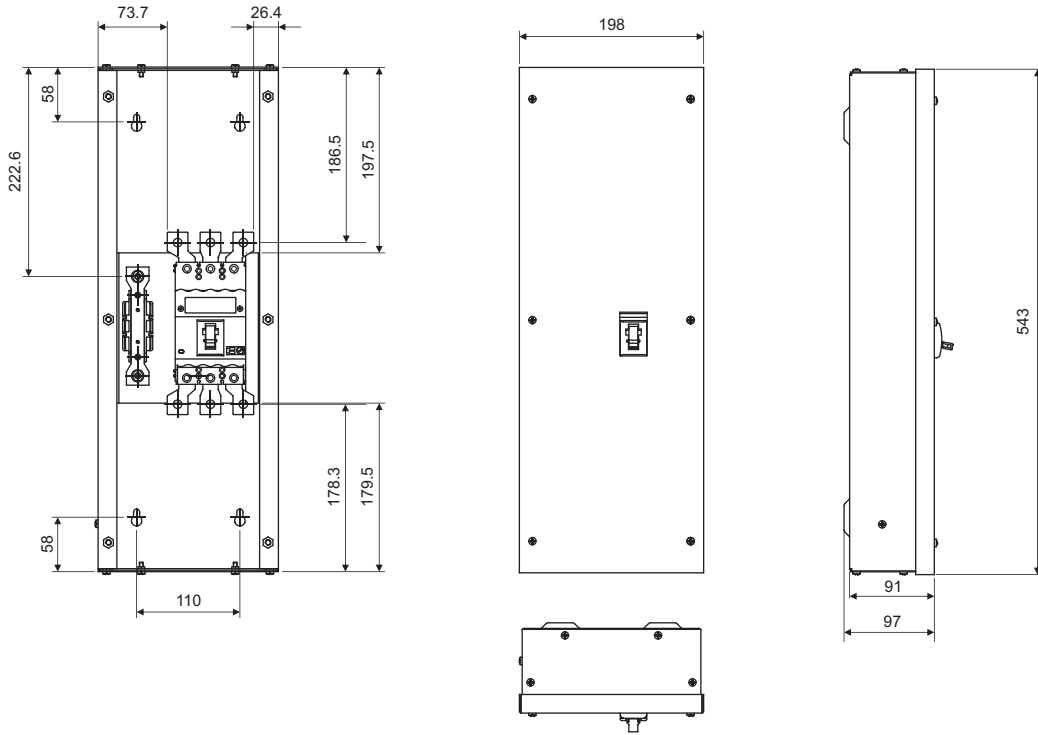

## Size II Enclosure for DU250/DU250C

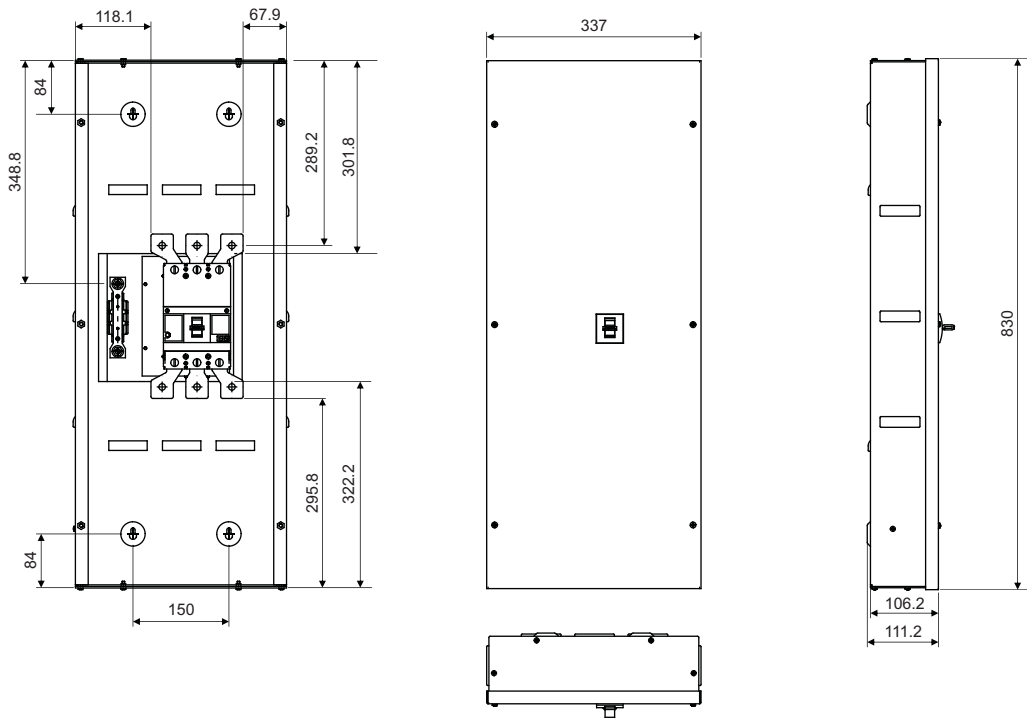

Ground Fault Modules are of Types GF1, GF2 and GF11. These modules are to be used with MCCBs for ground fault protection. The principle of operation is based on detection of the residual current in the system. They combine safety and versatility, conforming to the high performance standards, the characteristic of all E&A products.



**Ground Fault Module GF1**  
GF1 is suitable upto 200A MCCBs

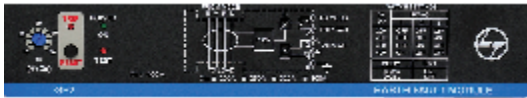

**Ground Fault Module GF2**  
GF2 is suitable upto  
200A to 400A MCCBs



**Ground Fault Module GF11**  
GF11 is suitable upto 800A MCCBs

## Features

- Compact in size
- Solid state design
- Built-in moulded CBCT for GF1 & GF2. External CTs are to be used for GF11
- Suitable for both 3 Phase 3 wire & 3 Phase 4 wire systems. In case of 3 phase 4 wire system, the natural cable/twisted link should also be passed through the CBCT along with the 3 Phase links / cables
- Built-in test facility
- Selection facility for nominal current rating ( $I_n$ )
- Earth fault setting is adjustable from 10% to 50% of set current
- Selectable trip times (100ms, 200ms)
- Manual reset for positive fault acknowledgment
- Potential free NO contact to trip MCCB (through 240V shunt release)
- Window dimensions suitable for Cable / Link connection in GF1 and GF2

**Note:** MCCBs need to be fitted with 110V / 240V as shunt release for Ground Fault Module operation.

## Technical Data

Specification	Type GF1 / GF2 / GF11
Current Setting Range, $I_s$ ( $I_s = x I_n$ )	10% to 50% $I_n$ in step of 10%
Auxiliary Supply	240V AC $\pm 20\%$
Time Delay (ms)	100 / 200ms Field selectable
Pick-up Accuracy	$\pm 10\% I_s$
Output Contact	1 NO contact manual reset type contact rating 5A 240V AC
Indication	a) Power on LED b) Trip LED (manual reset)
Operating Temperature	+10°C to +55°C
Insulation	2kV 50Hz for one minute across independent circuit 1kV 50Hz for one minute across open contacts
Mounting	Baseplate mounting type
Window for Cable / Busbar Entry (mm <sup>2</sup> )	<b>GF1</b> - 110 x 32 <b>GF2</b> - 165 x 61.5
Weight (kg)	<b>GF1</b> - 1.2, <b>GF2</b> - 2.2, <b>GF11</b> - 0.9

**Note :** Please check GF module window size & MCCB busbar width with spreaders / without spreaders before selection of GF Module.  
Please contact nearest branch office for further information.



## GF1

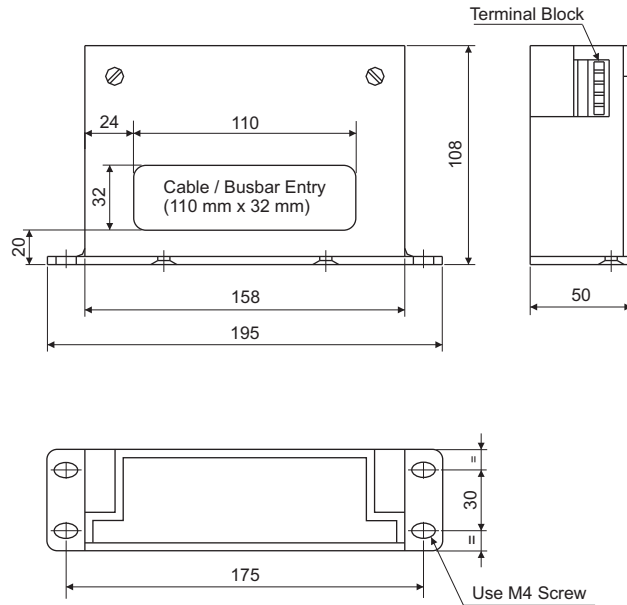

## GF2

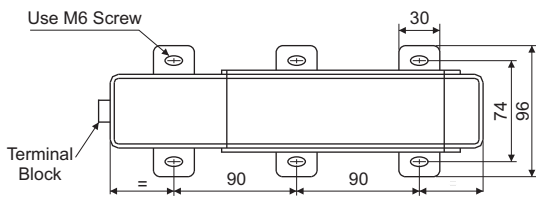
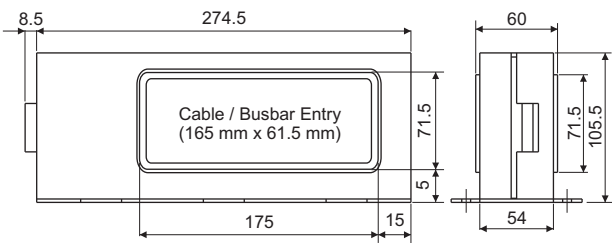

## GF11

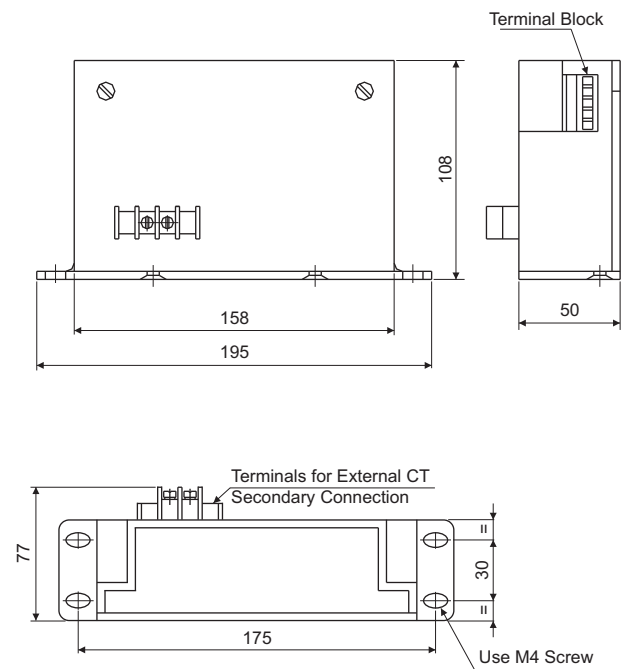

# Get the Switchgear Training Edge!

Aimed at maximizing productivity, conserving energy, minimizing costs and enhancing safety, our Electrical & Automation training programmes have benefitted over 2.25 Lakh professionals in the last 32 years. These training programmes are highly beneficial as they provide right exposure and impart knowledge on selection, installation, maintenance and testing of Electrical & Automation Products.

## So gain the advantage and go the extra mile with:

- 14 courses on contemporary topics
- Courses applicable to all switchgear brands
- Training Centers in Pune, Lucknow, Coonoor, Vadodara, Delhi & Kolkata
- Blend of theory and practical experience

## The typical training programmes cover:

- Low Voltage & Medium Voltage Switchgear
- Switchboard Electrical Design
- AC Drives & Building Management Solutions
- Protective Relays & Earthing
- Power Quality Solutions

Please contact any of the training centres for participation and detailed training programme schedule.



### Pune

L&T Electrical & Automation  
Switchgear Training Centre,  
T-156/157, MIDC  
Bhosari, Pune - 411 026  
Tel: 020 2712 0037 / 2712 0653  
Fax: 020 2712 2933  
E-mail: stc-pune@Lntebg.com



### Lucknow

L&T Electrical & Automation  
Switchgear Training Centre,  
C - 6 & 7, UPSIDC  
P. O. Sarojinagar, Lucknow - 226 008  
Tel: 0522 247 6015 / 97944 54455  
Fax: 0522 247 6015  
E-mail: stc-lucknow@Lntebg.com



### Coonoor

L&T Electrical & Automation  
Switchgear Training Centre,  
Ooty-Coonoor Main Road  
Yellanahalli P.O., The Nilgiris - 643 243  
Tel. : 0423 251 7107  
Fax : 0423 251 7158  
E-mail: stc-coonoor@Lntebg.com



### Vadodara

L&T Electrical & Automation  
Switchgear TrAZaining Centre  
Behind L&T Knowledge City,  
Near Village Ankhola,  
Vadodara - 390019  
Tel: 0265 2457805  
E-mail: stc-vadodara@Lntebg.com



### Delhi

L&T Electrical & Automation  
Switchgear Training Centre  
32, Shivaji Marg,  
Near Motinagar Metro Station,  
New Delhi - 110015  
Tel: 011 41419515 / 41419695 / 41419500  
Fax: 011 41419600  
E-mail: stc-delhi@Lntebg.com

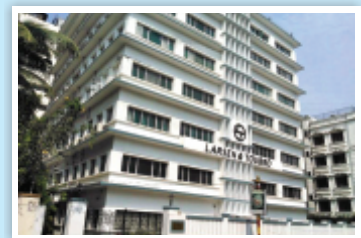

### Kolkata

L&T Electrical & Automation  
Switchgear Training Centre  
4th Floor, 3B, Shakespeare Sarani,  
Kolkata - 700071  
Tel: 033 42005975 / 42005978  
E-mail: stc-kolkata@Lntebg.com









## Electrical Standard Products (ESP) Offices:

### HEAD OFFICE

L&T Electrical & Automation  
L&T Business Park, TC 2, Tower 'B'  
3rd Floor, Gate No 5  
Saki Vihar Road, Powai  
**Mumbai 400 072**  
Tel: 022-67052874 / 2737 / 1156  
e-mail: cic@LNTEBG.com

### BRANCH OFFICES

L&T Electrical & Automation  
501, Sakar Complex I  
Opp. Gandhigram Rly. Station  
Ashram Road  
**Ahmedabad 380 009**  
Tel: 079 4900 4000/4001  
e-mail: esp-ahm@LNTEBG.com

L&T Electrical & Automation  
No 38, Cubbon Road  
**Bengaluru 560 001**  
Tel: 080-46136103 / 100  
e-mail: esp-blr@LNTEBG.com

L&T Electrical & Automation  
131/1, Zone II, Maharana Pratap Nagar  
**Bhopal 462 011**  
e-mail: esp-bho@LNTEBG.com

L&T Electrical & Automation  
Plot No. 559, Annapurna Complex  
Lewis Road  
**Bhubaneswar 751 014**  
Tel: 0674-2436690 / 2436696  
e-mail: esp-bsr@LNTEBG.com

L&T Electrical & Automation  
Aspire Towers, 4th Floor  
Plot No. 55, Phase-I  
Industrial & Business Park  
**Chandigarh 160 002**  
Tel: 0172-4646840 / 41 / 42 / 46 / 53  
e-mail: esp-chd@LNTEBG.com

L&T Electrical & Automation  
L&T Construction Campus  
TC-1 Building, II Floor  
Mount-Poonamallee Road  
Manapakkam  
**Chennai 600 089**  
Tel: 044-2270 6800  
e-mail: esp-maa1@LNTEBG.com

L&T Electrical & Automation  
67, Appuswamy Road, Post Bag 7156  
Opp. Nirmala College  
**Coimbatore 641 045**  
Tel: 0422-4588120 / 1 / 5  
e-mail: esp-cbe@LNTEBG.com

L&T Electrical & Automation  
3rd Floor, 1&2 Vijay Park,  
Main Chakrata road  
Ballupur Chowk  
**Dehradun 248001**  
Tel: +91 9582252411

L&T Electrical & Automation  
Khairasol, Degaul Avenue  
**Durgapur 713 212**  
Tel: 0343-2540448 / 2540449 / 2540443  
e-mail: esp-dgp@LNTEBG.com

L&T Electrical & Automation  
5, Milanpur Road, Bamuni Maidan  
**Guwahati 781 021**  
Tel: +91 8876554417  
e-mail: esp-ghy@LNTEBG.com

L&T Electrical & Automation  
2nd Floor, Vasantha Chambers  
5-10-173, Fateh Maidan Road  
**Hyderabad 500 004**  
Tel: 040-67015052  
e-mail: esp-hyd@LNTEBG.com

L&T Electrical & Automation  
Monarch Building, 1st Floor  
D-236 & 237, Amrapali Marg  
Vaishali Nagar  
**Jaipur 302 021**  
Tel: 0141-4385914 to 18  
e-mail: esp-jai@LNTEBG.com

L&T Electrical & Automation  
Akashdeep Plaza, 2nd Floor  
P. O. Golmuri  
**Jamshedpur 831 003**  
Jharkhand  
Tel: 0657-2340502 / 08  
e-mail: esp-jam@LNTEBG.com

L&T Electrical & Automation  
Skybright Bldg; M. G. Road  
Ravipuram Junction, Ernakulam  
**Kochi 682 016**  
Tel: 0484-4409420 / 4 / 5 / 7  
e-mail: esp-cok@LNTEBG.com

L&T Electrical & Automation  
3-B, Shakespeare Sarani  
**Kolkata 700 071**  
Tel: 033-48006001  
e-mail: esp-ccu@LNTEBG.com

L&T Electrical & Automation  
No. 10, Fortuna Tower, 2nd Floor  
Rana Pratap Marg, Near NBRI  
**Lucknow 226001**  
e-mail: esp-lko@LNTEBG.com

L&T Electrical & Automation  
No: 73, Karpaga Nagar, 8th Street  
K. Pudur  
**Madurai 625007**  
Tel: 0452-2567405 / 2561068 / 2561657  
e-mail: esp-mdu@LNTEBG.com

L&T Electrical & Automation  
L&T Business Park, TC 2, Tower 'B'  
3rd Floor, Gate No 5  
Saki Vihar Road, Powai  
**Mumbai 400 072**  
Tel: 022-67052874 / 2737 / 1156  
e-mail: esp-bom@LNTEBG.com

L&T Electrical & Automation  
Unnati Building, 2nd Floor  
Automation Campus  
A-600, TTC Industrial area  
Shil-Mahape road, Mahape  
**Navi Mumbai 400710**  
Tel: +91 22 67226502 / 67226300

L&T Electrical & Automation  
12, Shivaji Nagar  
North Ambajhari Road  
**Nagpur 440 010**  
Tel: 0712-2260012 / 6606421  
e-mail: esp-nag@LNTEBG.com

L&T Electrical & Automation  
32, Shivaji Marg,  
Near Moti Nagar,  
P. O. Box 6223  
**New Delhi 110 015**  
Tel: 011-41419514 / 5 / 6  
e-mail: esp-del@LNTEBG.com

L&T Electrical & Automation  
Grand Chandra, 2nd Floor  
Fraser Road  
Opposite Doordarshan Kendra  
**Patna 800001**  
e-mail: esp-patna@LNTEBG.com

L&T Electrical & Automation  
L&T House  
P. O. Box 119  
191/1, Dhole Patil Road  
**Pune 411 001**  
Tel: 020-48544395 / 48544279  
e-mail: esp.pnq@LNTEBG.com

L&T Electrical & Automation  
Crystal Tower,  
4th Floor, G. E. Road  
Telibandha  
**Raipur 492 006**  
Tel: 0771-4283214  
e-mail: esp-raipur@LNTEBG.com

L&T Electrical & Automation  
3rd Floor  
Vishwakarma Chambers  
Majura Gate, Ring Road  
**Surat 395 002**  
Tel: 0261-2473726  
e-mail: esp-sur@LNTEBG.com

L&T Electrical & Automation  
Radhadaya Complex  
Old Padra Road  
Near Charotar Society  
**Vadodara 390 007**  
Tel: 0265-6613610 / 1 / 2  
e-mail: esp-bar@LNTEBG.com

L&T Electrical & Automation  
Door No. 49-38-14/3/2, 1st floor,  
NGGO's Colony, Akkayyapalem,  
**Visakhapatnam 530 016**  
Tel: 0891-2791126 / 2711125  
e-mail: esp-viz@LNTEBG.com

Product improvement is a continuous process. For the latest information and special application, please contact any of our offices listed here. Product photographs shown for representative purpose only.



**L&T Electrical & Automation**

### L&T Electrical & Automation, Electrical Standard Products

L&T Business Park, TC-2, Tower B, 3rd Floor, Gate No. 5, Saki Vihar Road, Powai,  
Mumbai - 400 072, INDIA [www.Lntebg.com](http://www.Lntebg.com)

### Customer Interaction Center (CIC)

BSNL / MTNL (toll-free): 1800 233 5858 Reliance (toll-free): 1800 200 5858  
Tel: 022 6774 5858 Email: [cic@Lntebg.com](mailto:cic@Lntebg.com) Web: [www.Lntebg.com](http://www.Lntebg.com)