

CIRCUIT ANALYSIS FOR COMPLETE IDIOTS

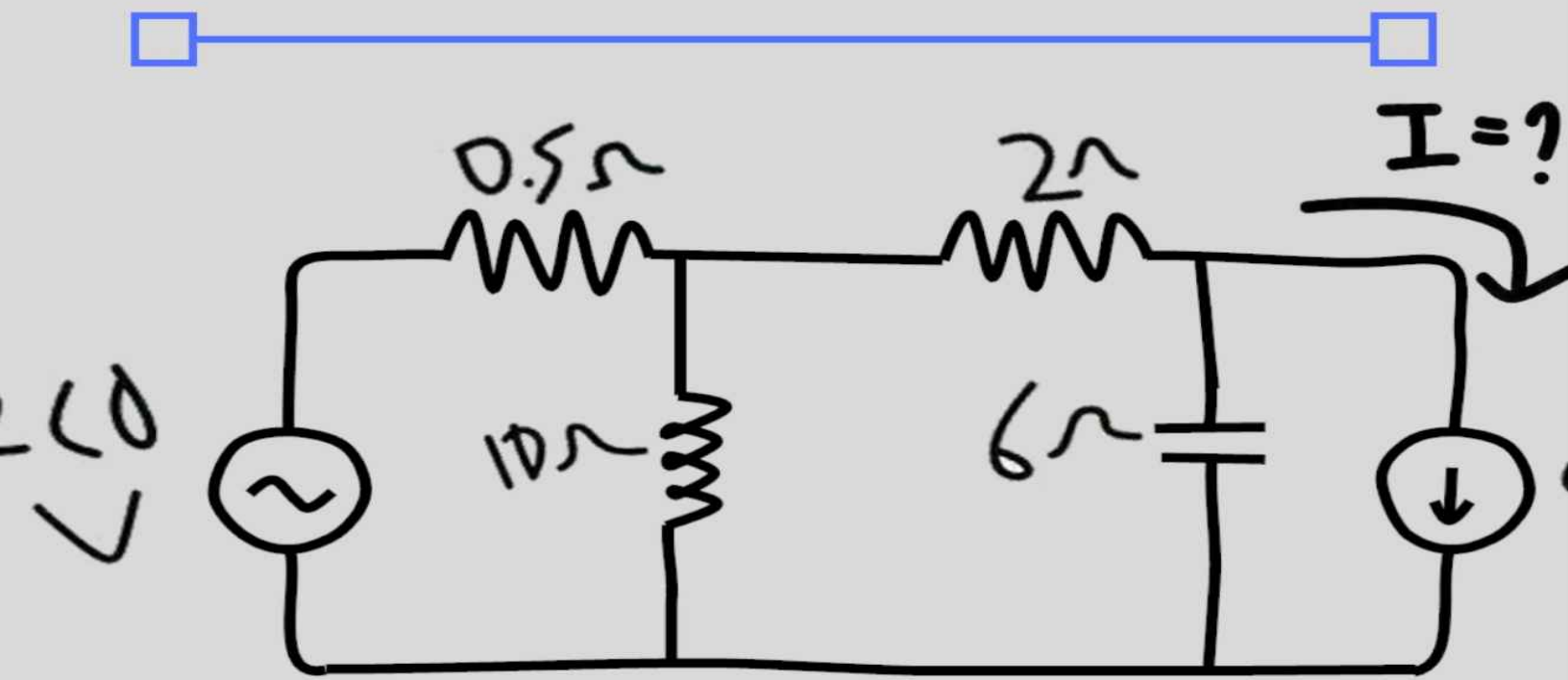

Ohm's Law

$$V = IR$$

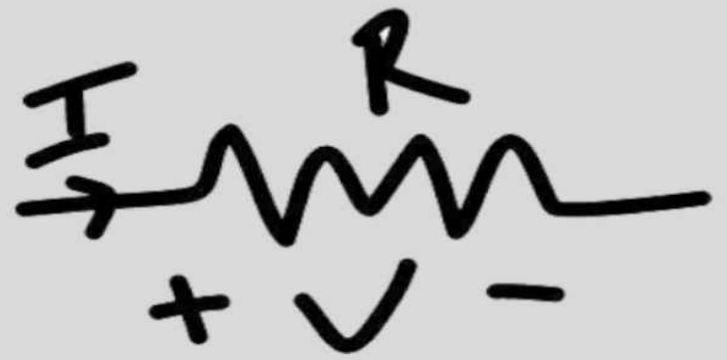

DAVID SMITH

CIRCUIT ANALYSIS FOR COMPLETE
IDIOTS

by David Smith

All Rights Reserved. No part of this publication may be reproduced in any form or by any means, including scanning, photocopying, or otherwise without prior written permission of the copyright holder. Copyright © 2019

Other books in the Series:

[Arduino for Complete Idiots](#)

[Digital Signal Processing for Complete Idiots](#)

[Control Systems for Complete Idiots](#)

Basic Electronics for Complete Idiots

Digital Electronics for Complete Idiots

Electromagnetic Theory for Complete Idiots

Table of Contents

PREFACE

1. INTRODUCTION

2. VOLTAGE & CURRENT LAWS

3. BASIC ANALYSIS TECHNIQUES

4. NETWORK THEOREMS

5. CAPACITANCE

6. INDUCTANCE

7. AC FUNDAMENTALS

8. AC CIRCUITS

9. ANALYSIS TECHNIQUES (FOR AC)

10. NETWORK THEOREMS (FOR AC)

11. LAPLACE TRANSFORM

12. TRANSIENT ANALYSIS

13. 3-PHASE SYSTEMS

REFERENCES

CONTACT

PREFACE

In today's world, there's an electronic gadget for everything and inside these gadgets are circuits, little components wired together to perform some meaningful function. Have you wondered how a led display sign works or how a calculator works or toy cars work? How is it possible?? Answer, all because of electrical circuits. These tiny components when arranged in certain manner can do wonders. Fascinating isn't it? Our fascination with gadgets and reliance on machinery is only growing day by day and hence from an engineering perspective, it is absolutely crucial to be familiar with the analysis and designing of such Circuits, at least identify components.

Circuit analysis is one of basic subjects in engineering and particularly important for Electrical and Electronics students. So circuit analysis is a good starting point for anyone wanting to get into the field. It is a very easy subject to learn and understand, but messing up these ideas or misunderstanding them, will lead to a lot of headache in other subjects. In this book we provide a concise introduction into basic Circuit analysis. A basic knowledge of Calculus and some Physics are the only prerequisites required to follow the topics discussed in the book. We've tried to explain the various fundamental concepts of Circuit theory in the simplest manner without an over reliance on math. Also, we have tried to connect the various topics with real life situations wherever possible. This way even first timers can learn the basics of Circuit theory with minimum effort. Hopefully the students will enjoy this different approach to Circuit Analysis. The various concepts of the subject are arranged logically and explained in a simple reader-friendly language with illustrative figures.

This book is not meant to be a replacement for those standard Circuit theory textbooks, rather this book should be viewed as an introductory text for beginners to come in grips with advanced level topics covered in those books. This book will hopefully serve as inspiration to learn Circuit theory in greater depths.

Readers are welcome to give constructive suggestions for the improvement of the book and please do leave a review.

1. INTRODUCTION

1.1 ELECTRICAL CHARGE

Have you ever wondered what Electricity is and where it comes from? To answer these questions, we have to start with the atom. Although we are more interested in the properties of electricity than the phenomenon itself, it wouldn't hurt us to quickly discuss the basics.

Everything in the universe is made of atoms and every atom consists of 3 types of particles, neutrons, protons and electrons. Neutrons and protons are packed together in the nucleus and make up the center of an atom, whereas the electrons move around the nucleus in a constant motion. For this discussion, we are only concerned about protons and electrons or more specifically, a property these two particles possess called the Electric Charge. Although it is very unlikely you'll ever come across a proper definition for charge, the best we can come up with is, that charge is a form of electrical energy. Protons have a positive charge and Electrons have a negative charge. In a normal atom, the number of protons is equal to the number of electron and thus the atom as a whole is electrically neutral. Neutral objects aren't of much interest to us, we are more interested in charged bodies. Electric Charge is denoted by the letter Q .

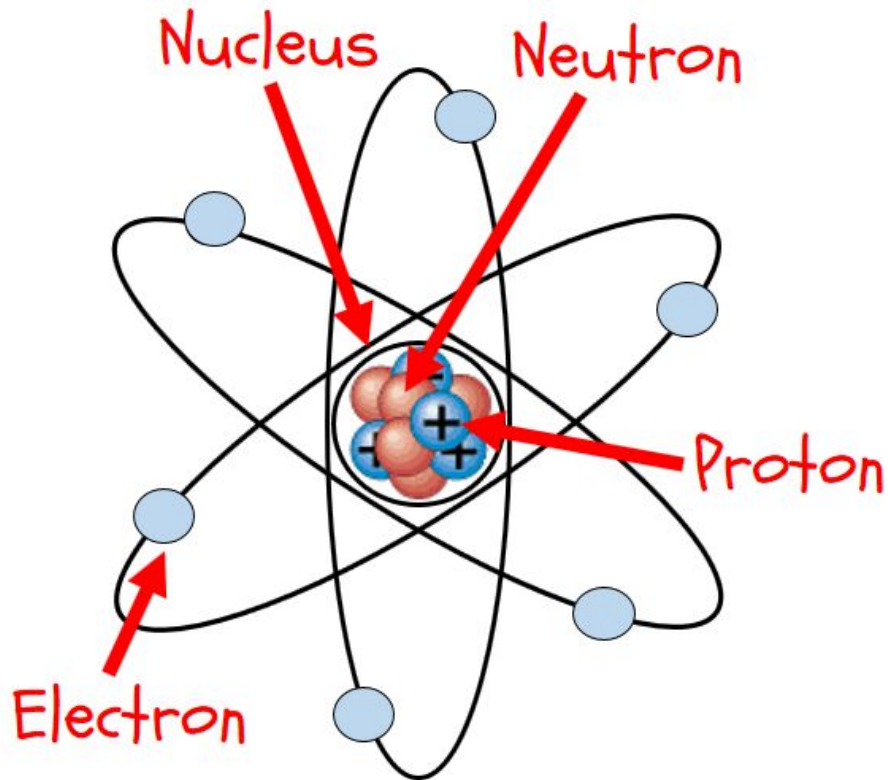

The SI unit of electric charge is Coulomb (C) and it is the charge possessed by 6.24×10^{18} electrons.

1.2 CURRENT

Previously we mentioned that free electrons are responsible for the flow of Electric Current. The concept behind this phenomenon is very simple, whenever a charged particle moves, it produces an Electric Current. Obviously the protons can't move, because they are inside the nucleus. And the electrons close to the nucleus are held tightly by the force of attraction, so they can't move either. So the only way an Electric current is produced is through movement of outer electrons, called the free electrons (it's a little different in electronics though).

To understand this better, consider the inside section of a Conductor as shown below.

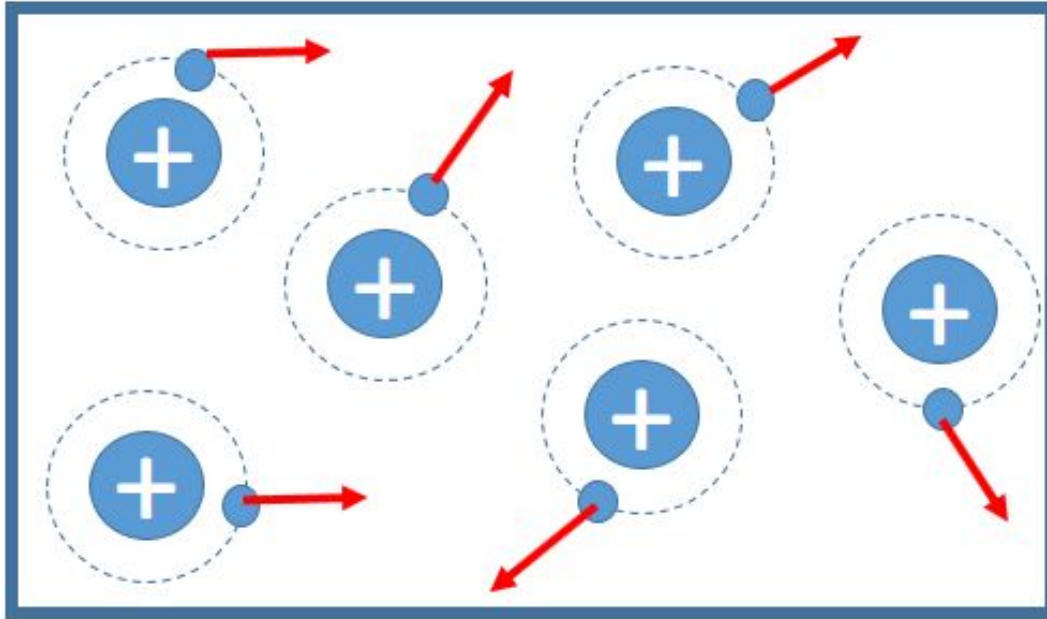

Conductors have tons of free electrons and they keep moving in random direction (due to thermal energy), and each of these small movements contribute to an Electric current. You might be thinking, if an electric current is produced this easily in a conductor, why do we need batteries and generators and power plants and stuff. Can't we just hook up a small piece of copper wire to a bulb and be done with it. Unfortunately, that won't work. That's because the currents produced by each free electron are in random direction (in accordance with the direction of their motion) and when we consider the conductor as a whole, these currents cancel each other out and net current is zero.

The way out of this problem is to make all the free electrons drift in one direction and thus the net Electric Current adds up to a non-zero value. To do this all we need is a little effort, a force of sorts, called the EMF or the Electromotive Force. We will discuss more about the EMF in the next section.

So Electric Current can be defined as the flow of charge (electrons) when subjected to an EMF. Or the more accurate definition would be, **Current is the rate of flow of charge**. Mathematically, Current I is equal to,

$$I = \frac{Q}{t}$$

The unit of current is Ampere, named after French mathematician and physicist [André-Marie Ampère](#). One ampere of current represents one coulomb of electrical charge moving past a specific point in one second.

1.3 EMF

EMF stands for Electromotive force. The name may give you the impression that electromotive force is a type of force. Actually, it is not. As mentioned in the previous section, EMF or the Electromagnetic force is an energy that can cause current to flow in an electrical circuit or device. This means that a current can flow in a circuit or a device, only if an EMF is provided. Sources of EMF can be batteries, solar cells, generators etc. EMF is denoted by the symbol E and is measured in unit Volt (V).

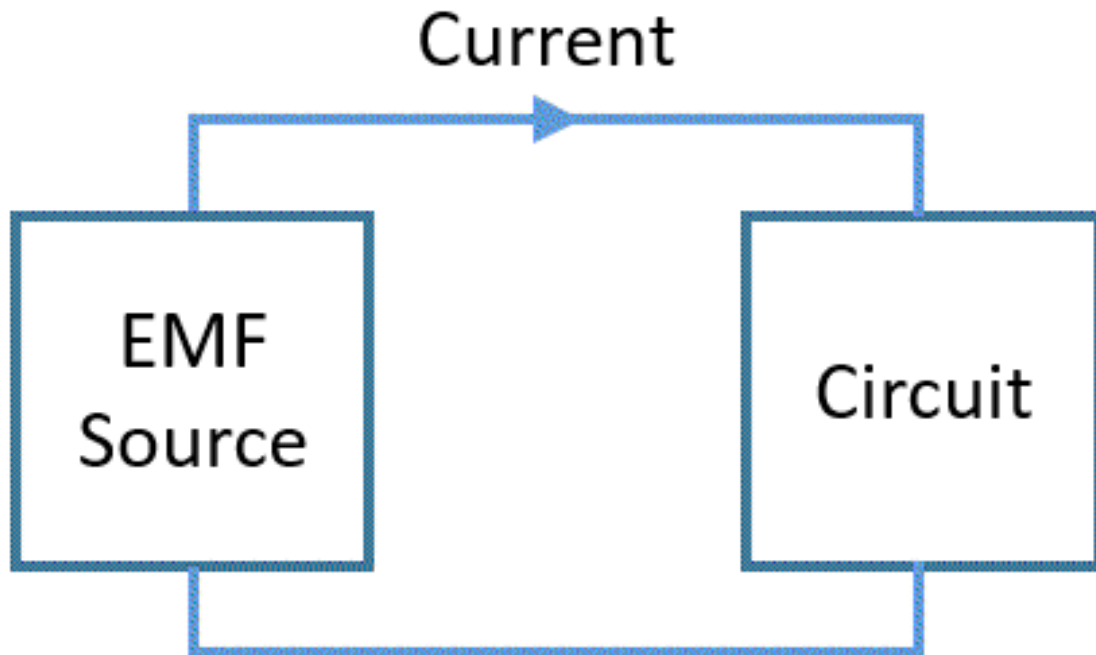

1.4 POTENTIAL DIFFERENCE

Both EMF and Potential Difference are closely related and are often used interchangeably in many places, but they aren't the same quantities. When a current flows through a material, the electrons are accelerated due to the applied EMF. But these electrons don't gain much velocity, because they keep colliding with ions in the material and due to this, the kinetic energy of the electrons is converted to heat. What this means is that, the electrons at one of the material has more energy than the electrons at the other end, which leads to a potential difference. This obviously is a rough explanation, the actual physics behind phenomenon is more complex and beyond the scope of this book. It is important to note that, Potential difference is always measured between 2 points and never at a single point.

To sum up, the EMF is the driving force that keeps electrons in motion and Potential difference is the difference in energy of the electrons as a current is passed through a material. Both EMF and Potential difference have the

common unit Volt (V). The term Voltage can be used in place of Potential difference or EMF.

1.5 OHM'S LAW

From the previous sections itself, it must be pretty clear that the Voltage and the Current are two closely related quantities. They have a cause effect relation as given by this general equation:

$$\text{Effect} = \frac{\text{Cause}}{\text{Opposition}}$$

Where the Voltage is the cause and the Current is the effect. Now the question is, what could possibly be the opposition to current? This is where we introduce a quantity called Resistance. The concept of Resistance is analogous to friction in mechanics. Every material has a tendency to oppose current, but some more than the others. Materials with large no. of free electrons like metals have low resistance or a low tendency to oppose current. Such materials are called **Conductors**. Whereas materials with small no. of free electrons like plastic have high resistance. Such materials are called **Insulators**. And some materials fall in between, they offer some resistance, but not very high either. They are called **Semi-conductors**.

Now let's substitute the terms we introduced so far into our general equation from earlier.

$$\text{Current} = \frac{\text{Voltage}}{\text{Resistance}}$$

$$I = \frac{V}{R} \quad \leftarrow \text{Ohm's Law}$$

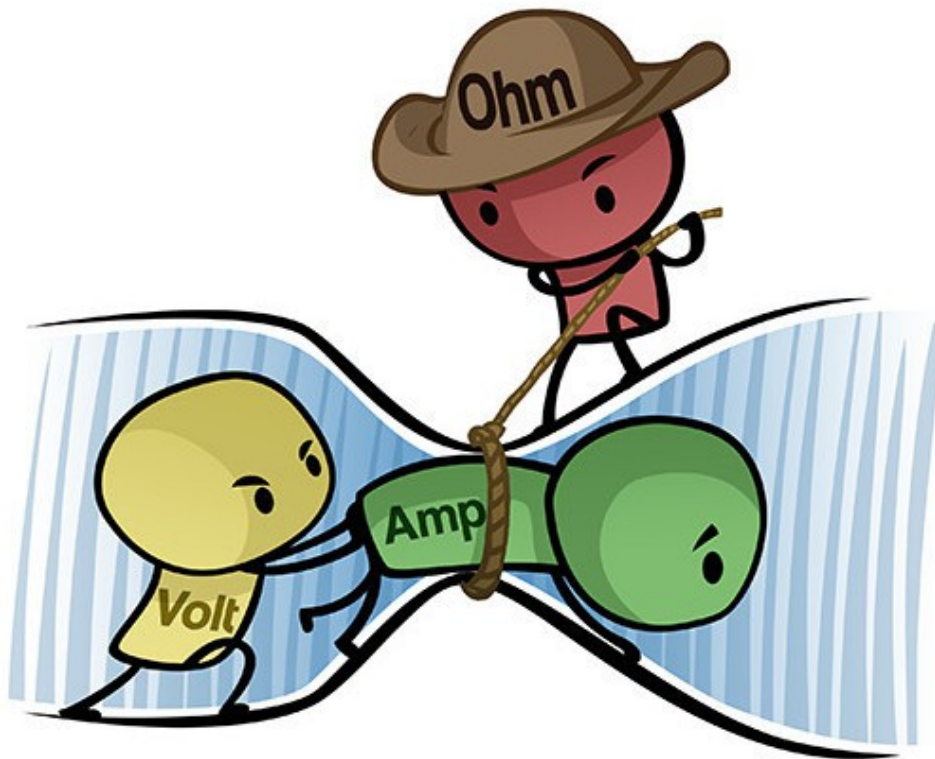

The result is this beautiful equation called the Ohm's Law, after the German physicist and mathematician [Georg Simon Ohm](#) (weird name right??). It's one of the most fundamental things there is in electrical engineering. Get used to it, because it will remain with you as long as you do anything electrical related.

The Ohm's law essentially implies that, **the current flowing through a material/circuit is directly proportional to the Voltage applied across it, provided that the resistance of the material remain fixed.** So if we were to apply twice the voltage across a bulb, twice the amount of current would flow through it or if we apply one third the voltage, then one third the current would flow. Graphically the Ohm's law would look like,

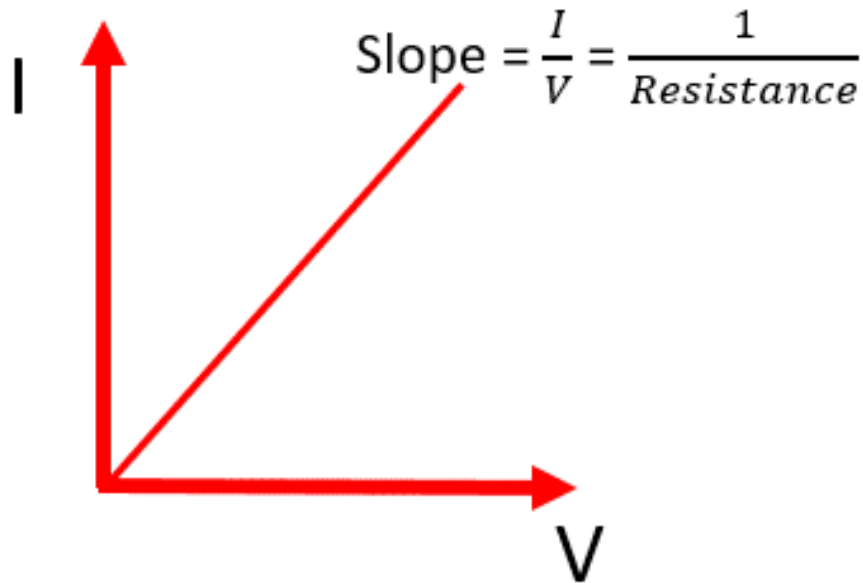

The Unit of Resistance is Ohm and is denoted by the Greek letter Ω .

1.6 CONDUCTANCE

While we are at it, let's define one more new quantity called Conductance. Conductance is the inverse of Resistance. It's a measure of how well a material allows current to flow through it. The Unit of Conductance is Siemens and is denoted by Ω^{-1} .

1.7 RESISTOR

Have you seen one of these tiny components in an electronic circuit before??



Those are resistors. A Resistor is a device that provide resistance in an electrical circuit. WHAT?? But isn't resistance a bad thing? Yes, resistance does oppose current and it does cause energy loss. But when used the right way it isn't always a bad thing. Do you know that resistance is the reason we have bulbs and heaters? Resistors are electrical components that help control the flow of current in a circuit. A high resistance means there is less current available for a given voltage. It is widely used in heating applications, for biasing, voltage dividers and tons of other applications.

The symbol for resistor is:

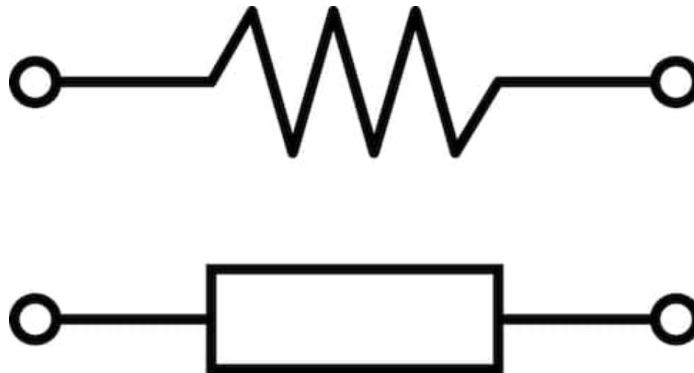

1.8 POWER

Electrical power is defined as the rate at which electrical energy is transferred from an energy source to a circuit. When current is passed through a resistor, energy is dissipated as heat. It is easy to calculate Electrical power, it is simply the product of the current (I) flowing through a component and the voltage (V) across the component.

$$P = VI$$

Applying the Ohm's law, 2 other forms of equation can be obtained,

$$P = \frac{V^2}{R}$$

$$P = I^2R$$

Unit of electrical power is Watts.

2. VOLTAGE & CURRENT LAWS

2.1 SERIES CIRCUIT

A series circuit is a circuit in which any number of components are connected one after the other, such that there is a single path for the flow of current. For example, in the circuit shown in the figure below, the Resistors R_1 and R_2 are in series, because they are connected at a common point b. Similarly, Resistor R_2 and the Voltage source are also in series, with the common point c.

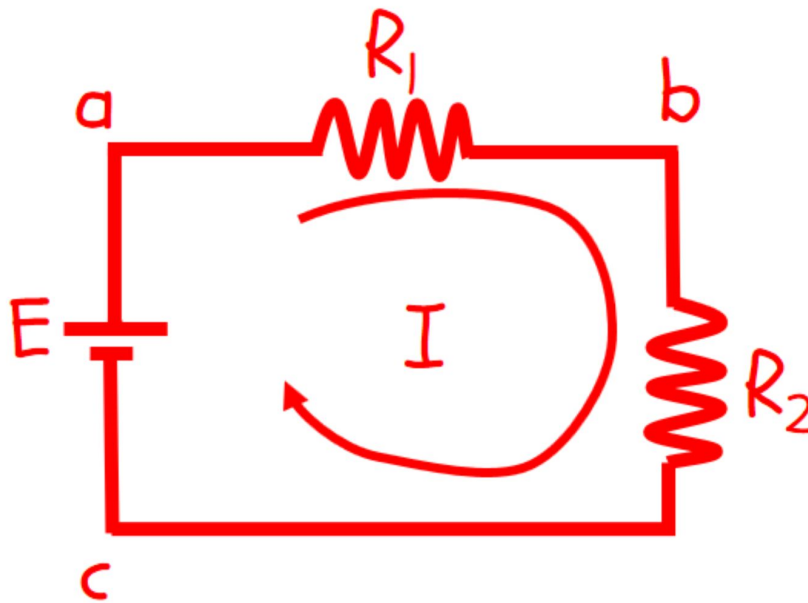

If there were any other components (that carry current) connected at any of these nodes (a, b or c), then this circuit wouldn't be a series circuit anymore. For instance, if there had been a third resistor R_3 connected between nodes a and b, as shown in the figure below, this is no longer a

series circuit. Clearly there are 2 paths for the current to flow, through R_1 & R_3 .

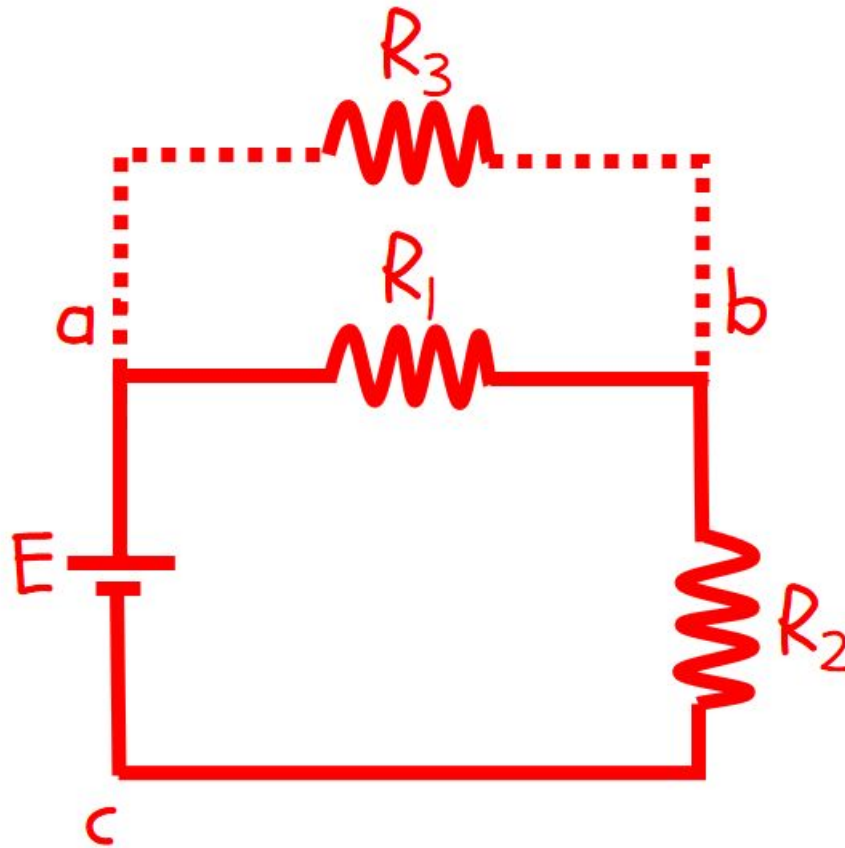

2.2 KIRCHHOFF'S VOLTAGE LAW (KVL)

Kirchhoff's Law's....Wait!! "Laws " you say?? You mean there's more than one law?? Yes, there are 2 Kirchhoff's Law's: Kirchhoff's Voltage law & the Kirchhoff's Current Law. Kirchhoff's laws are the most fundamental laws, next to the Ohm's law, in Electrical engineering. But fortunately, just like the Ohm's law, these are 2 really simple laws. Even simpler than the Ohm's Law I would say, because there is no formula, just a simple statement. The entire basis of Circuit analysis are these 2 laws and the Ohm's law. They are basically spin offs to the energy and charge

conservation laws. We'll get to the Kirchhoff's Current Law in later section. For now, we'll focus on the Kirchhoff's Voltage Law or the KVL.

Kirchhoff's voltage law (KVL) states that “**the algebraic sum of the potential rises and drops around a closed loop (or path) is zero**”.

Symbolically,

$$\sum_{\text{Closed Path}} V = 0$$

In layman's terms Kirchhoff's voltage law essentially means: “**Voltage supplied = Voltage used up, around a closed loop**”.

Forming a KVL equation is really easy, start at a certain point of the circuit and note down all the potential changes (either rises or drops) in one particular direction, till the starting point is reached once again. Then equate the resulting expression to zero. That's it.

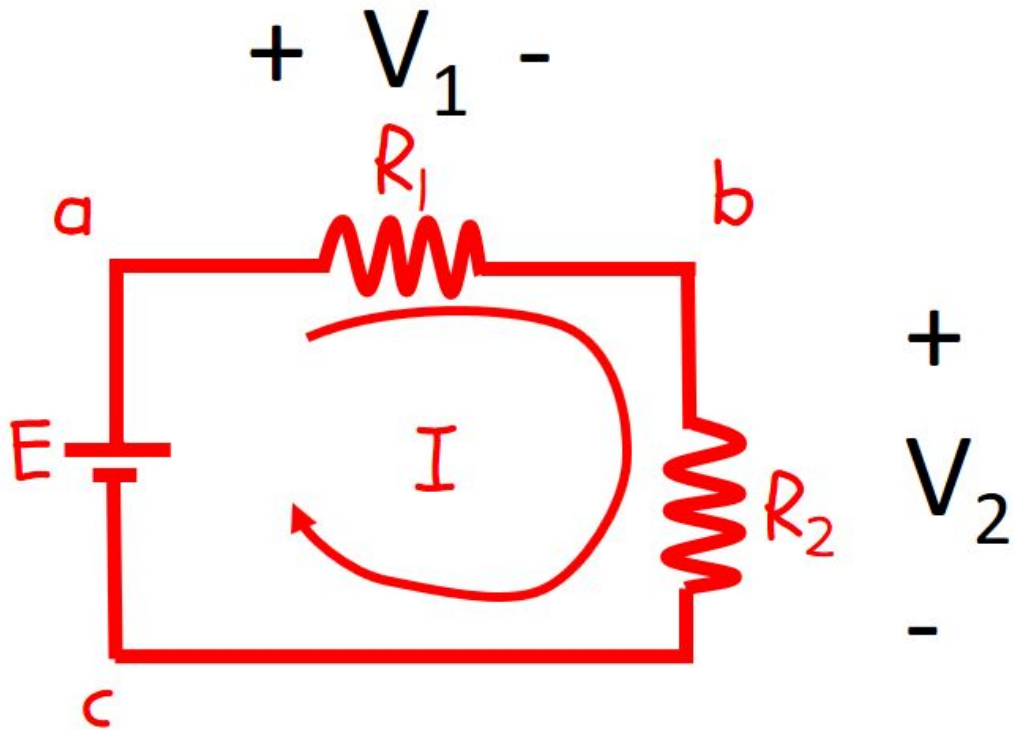

For the above Circuit, KVL equation is $E - V_1 - V_2 = 0$ or E (Voltage supplied) = $V_1 + V_2$ (Voltage Used up). Do note that KVL is applicable to all loops or closed paths, however complex the circuit maybe.

2.3 RESISTORS IN SERIES

When dealing with a circuit containing large no of components, it's a smart thing to simplify the circuit. This applies to resistors as well. A combination of resistors, be it series or parallel or otherwise can be replaced by a single resistance, called the equivalent or the effective resistance of the circuit. For a series combination of resistors, the equivalent resistance is found by simply adding the individual resistance values. Mathematically,

$$R_{\text{eq}} = R_1 + R_2 + \dots + R_N$$
$$= \sum_{i=1}^N R_i$$

The proof for this is pretty straight forward. Consider our example (first one) from section 2.1. Let V_1 & V_2 are the voltages across the resistors R_1 and R_2 respectively. Using KVL, we know $V = V_1 + V_2$. Therefore,

$$R_{\text{eq}} = \frac{V}{I} = \frac{V_1 + V_2}{I} = \frac{V_1}{I} + \frac{V_2}{I}$$

$$R_{\text{eq}} = R_1 + R_2$$

2.4 VOLTAGE DIVIDER RULE

In the last section, we saw that in a series connection, the resistors share a common current, but have different voltage drops across them. Now we will try to find out the exact magnitude of the voltage drops. For that we use the Voltage Divider Rule.

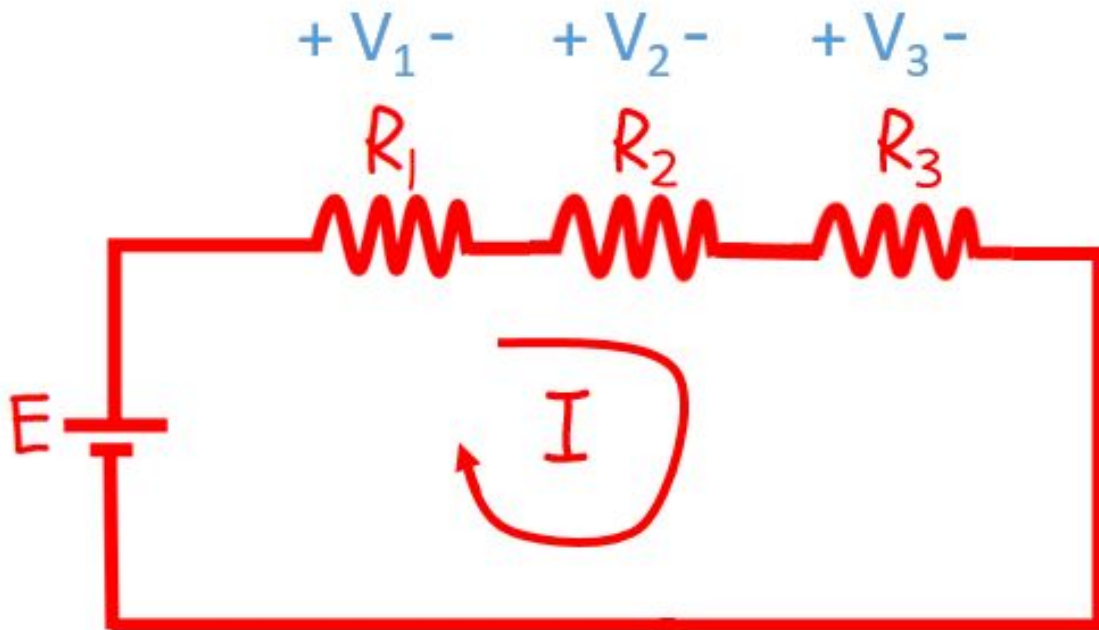

From Ohm's law,

$$I = \frac{E}{R_1 + R_2 + R_3} = \frac{E}{R_T}$$

Then the Voltage drops across the resistors are:

$$V_1 = IR_1, V_2 = IR_2, V_3 = IR_3$$

$$V_1 = \frac{E R_1}{R_T}, V_2 = \frac{E R_2}{R_T}, V_3 = \frac{E R_3}{R_T}$$

To sum up, the Voltage drop across a Resistor in series connection is given,

$$V_R = \frac{\text{(Voltage across combination)} \times \text{(Resistance } R)}{\text{Total Resistance}}$$

2.5 PARALLEL CIRCUIT

A parallel circuit is a circuit in which any number of components are connected across 2 common terminals, such that they share a common voltage. For example, in the circuit shown in the figure below, the Resistors R_1 and R_2 are in parallel, because they are connected between the same terminals a and b. The current will be divided amongst the resistors, according as their resistance values.

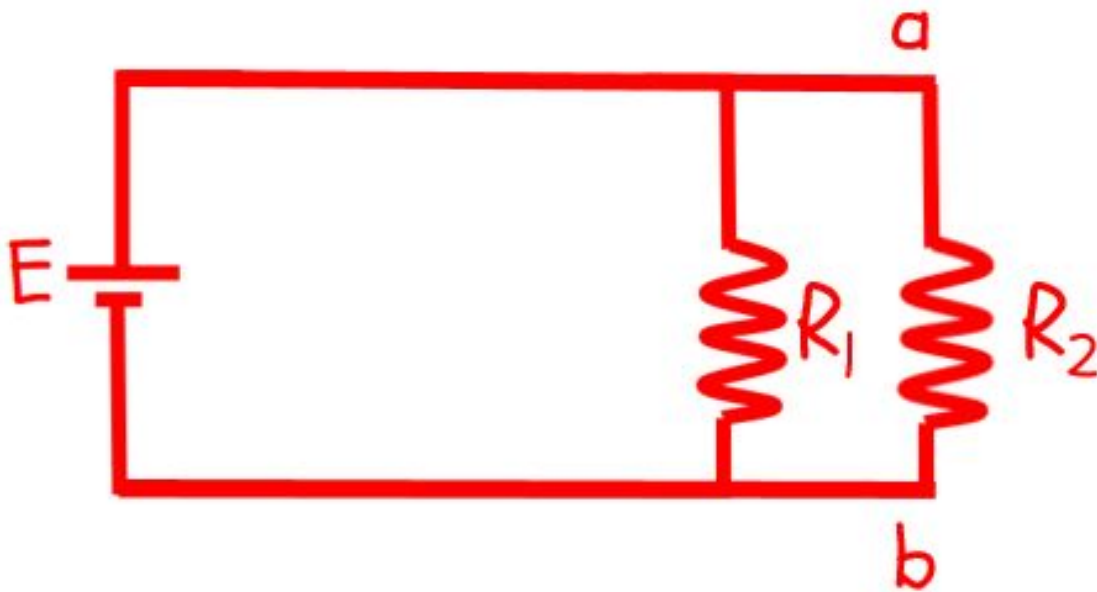

2.6 KIRCHHOFF'S CURRENT LAW (KCL)

According to the Kirchhoff's Current Law, **the algebraic sum of the currents entering and leaving a node or a junction of a circuit is zero.**

It's easily evident that this law is derived from the Law of conservation of charge. The idea is really simple, once a current is generated in a circuit, it is distributed throughout the circuit. It cannot just accumulate in a wire or vanish into thin air.

Symbolically,

$$\sum I_{entering} = \sum I_{leaving}$$

Consider the example shown below and let's formulate the KCL equation for node a. At node a, there are 3 currents, one entering and 2 leaving. Hence the KCL equation is, $I = I_1 + I_2$.

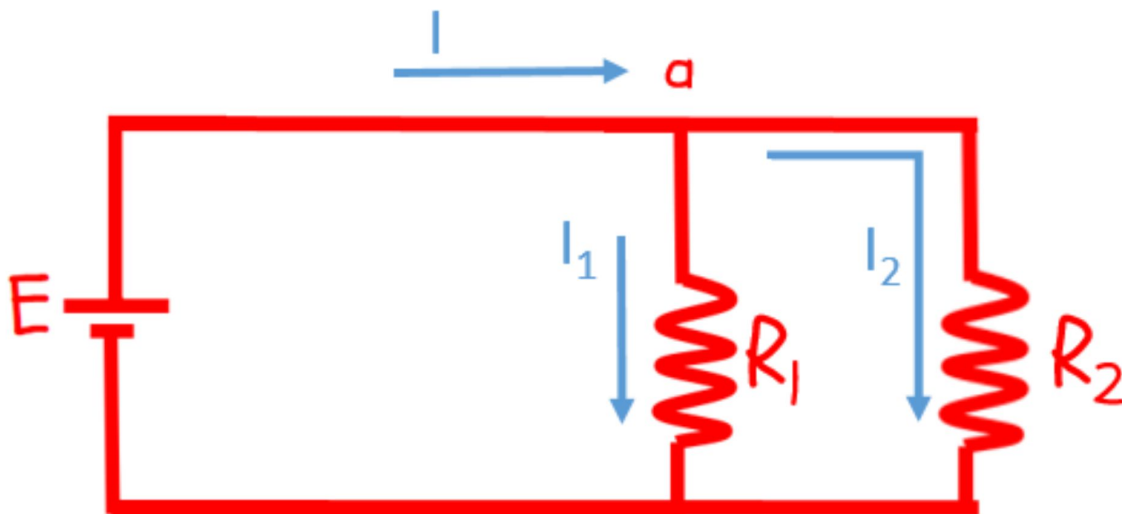

2.7 RESISTORS IN PARALLEL

For a parallel combination of resistors, the reciprocal of the equivalent resistance is the sum of the reciprocals of the individual resistances. Mathematically,

$$\begin{aligned}\frac{1}{R_{\text{eq}}} &= \frac{1}{R_1} + \frac{1}{R_2} + \dots + \frac{1}{R_N} \\ &= \sum_{i=1}^N \frac{1}{R_i}\end{aligned}$$

Consider our example from section 2.1. Let I_1 & I_2 be the currents flowing through the resistors R_1 and R_2 respectively. Using KCL, we know $I = I_1 + I_2$.

$$\frac{1}{R_{\text{eq}}} = \frac{I}{V} = \frac{I_1 + I_2}{V} = \frac{I_1}{V} + \frac{I_2}{V}$$

$$\boxed{\frac{1}{R_{\text{eq}}} = \frac{1}{R_1} + \frac{1}{R_2}}$$

2.8 CURRENT DIVIDER RULE

The Current Divider Rule is used to determine the magnitude of current entering each branch of a parallel connection.

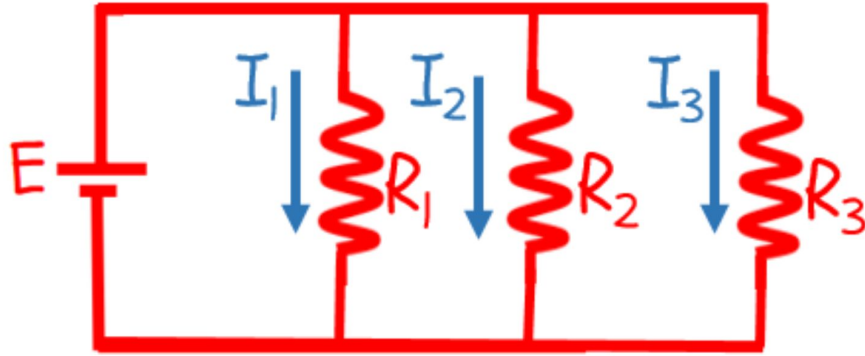

From Ohm's law,

$$I = \frac{E}{R_T}$$

Then the Currents flowing through resistors are:

$$I_1 = \frac{E}{R_1}, I_2 = \frac{E}{R_2}, I_3 = \frac{E}{R_3}$$

$$\therefore I_1 = \frac{IR_T}{R_1}, I_2 = \frac{IR_T}{R_2}, I_3 = \frac{IR_T}{R_3}$$

To sum up, the Current flowing through a Resistor in parallel connection is given by,

$$I_R = \frac{\text{(Total Current) x (Total Resistance)}}{\text{Resistance } R}$$

2.9 OPEN & SHORT CIRCUIT

Short Circuit is a condition where two points in a circuit are directly connected to each other through a path of zero resistance. The voltage across the 2 points will be always zero in case of a short circuit.

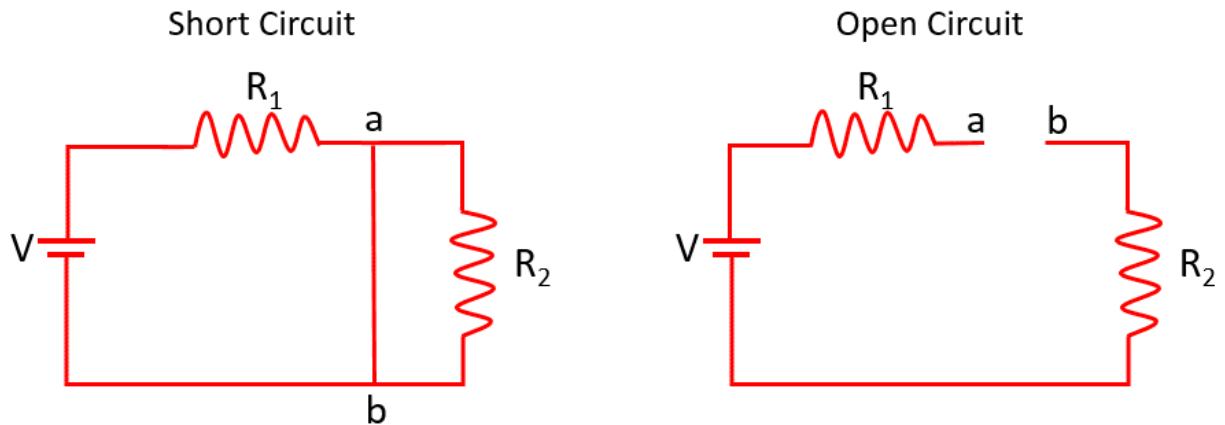

Open Circuit is exactly the opposite condition as short circuit. In case of an open circuit, there is no connection between two points in a circuit and hence no current flows between the 2 points.

3. BASIC ANALYSIS TECHNIQUES

3.1 ENERGY SOURCES

There are basically 2 types of energy sources: Voltage source & Current source. Again they can be classified as ideal & practical sources. First we'll discuss ideal sources then consider practical sources.

3.1.1 Voltage Source

An ideal Voltage source is an Energy source which gives constant Voltage across its terminals irrespective of the current drawn by the load connected to its terminals. At any instant of time, the voltage across the terminals remain the same. Thus the V-I Characteristics of an ideal voltage source is a straight line as shown.

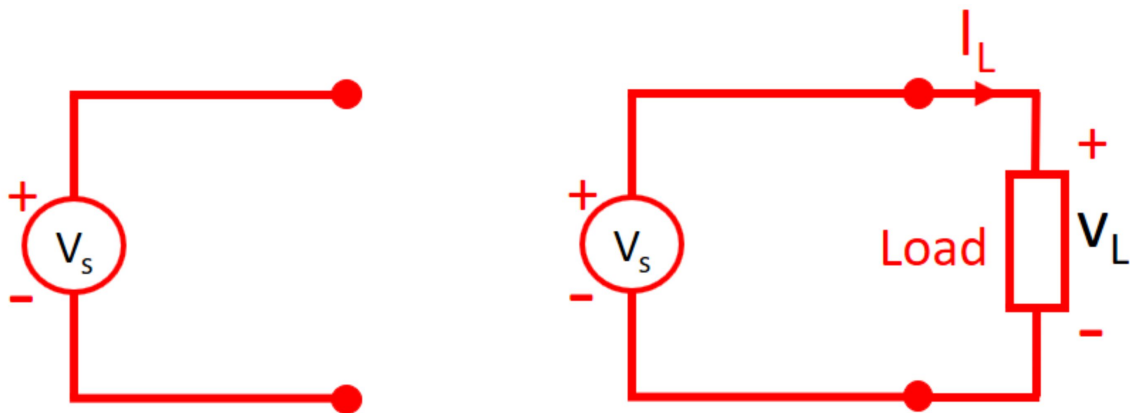

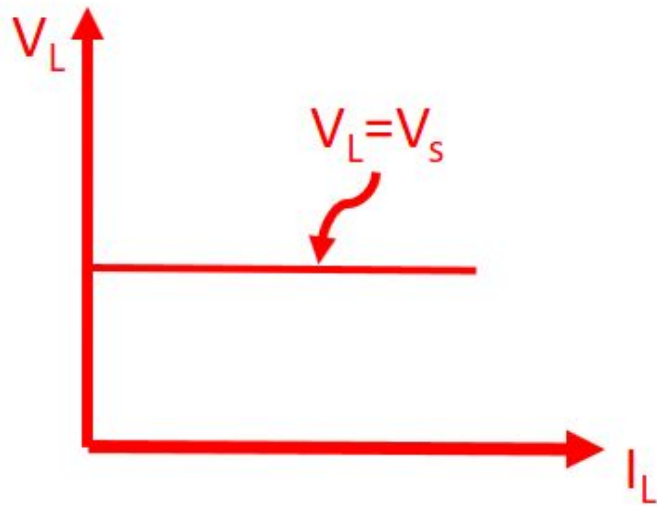

V-I Characteristics

But it is not possible to make such Voltage sources in practice. Practically, all Voltage sources have a small internal resistance. For analysis purposes, we assume that this internal resistance is in series with the voltage source and is represented by R_{se} . Because of R_{se} , the voltage across the terminals decreases slightly with the increase in the current.

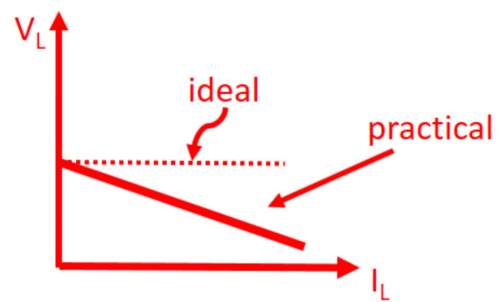
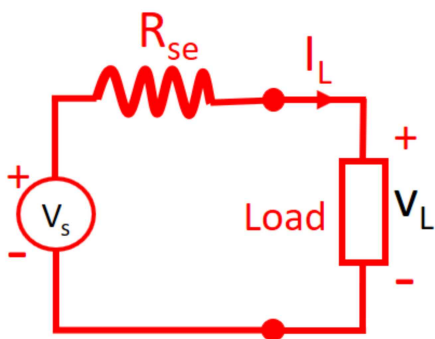

V-I Characteristics

$$V_L = V_s - I_L R_{se}$$

Usually, Voltage sources are manufactured keeping the internal resistance to the minimum, such that it acts more or less like an ideal voltage source (till a max load current limit). Batteries are an example of Voltage source.

3.1.2 Current Source

No prizes for guessing what a current source is, an ideal current source is a power source that gives constant current, irrespective of the voltage appearing across its terminals

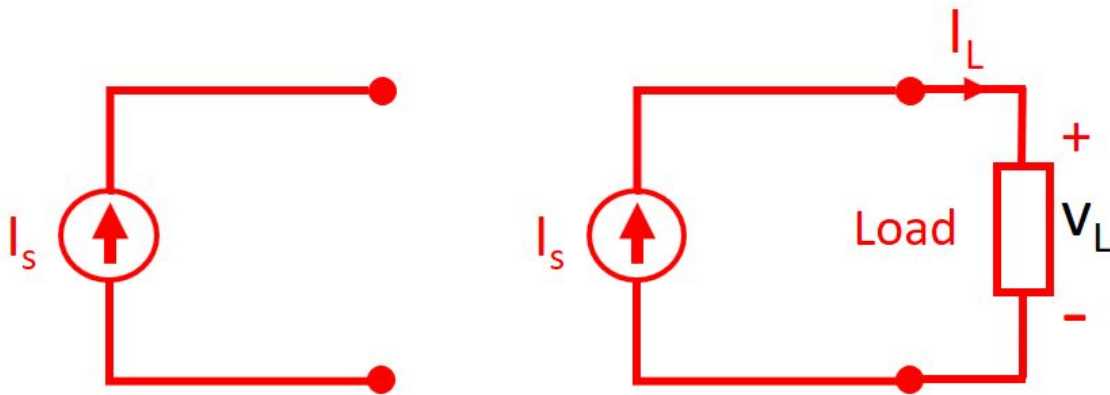

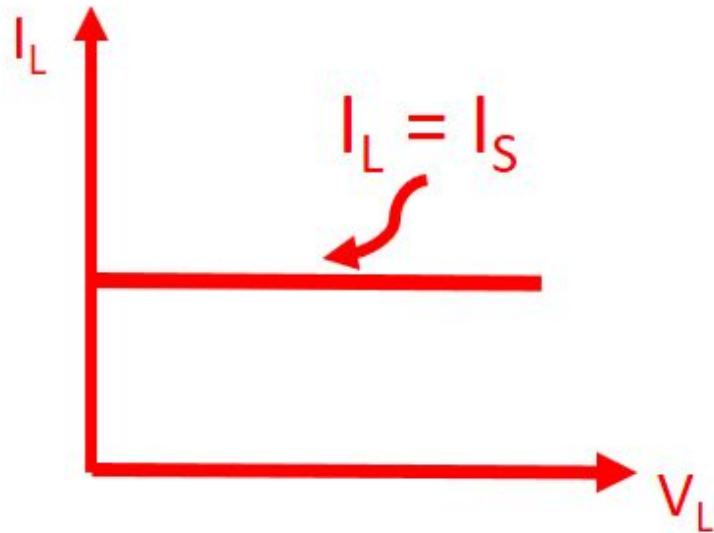

V-I Characteristics

But a practical Current source hardly ever functions this way. In a practical Current source, the current decreases slightly as the Voltage across the load terminals increase. This behavior can be analyzed by considering a high internal resistance, represented by R_{sh} in parallel with the source.

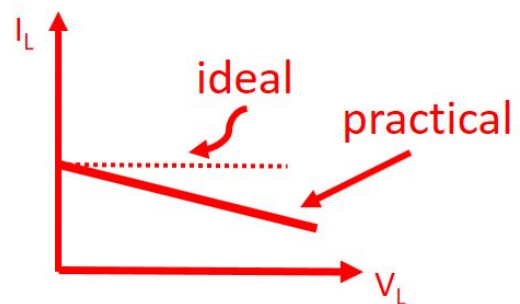
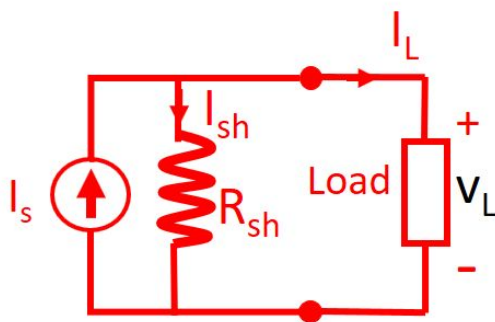

V-I Characteristics

$$I_L = I_s - \frac{V_L}{R_{sh}}$$

3.2 COMBINATION OF SOURCES

In many circuits, it is necessary to use multiple energy sources. Analyzing such circuits directly is a bit of a mess. So what we usually do is to reduce the multiple sources to a single equivalent source, making the analysis a lot easier. Like the resistors and other circuit components, power sources too can have series or parallel combinations.

3.2.1 Combination of Voltage sources

If two Voltage sources are in series i.e. they are connected back to back, the effective voltage is simply their algebraic sum. It is important to consider their polarities while doing so. If their polarities are the same, then the effective voltage is their sum and if their polarities are opposing, then the effective voltage is the difference of the 2 voltages.

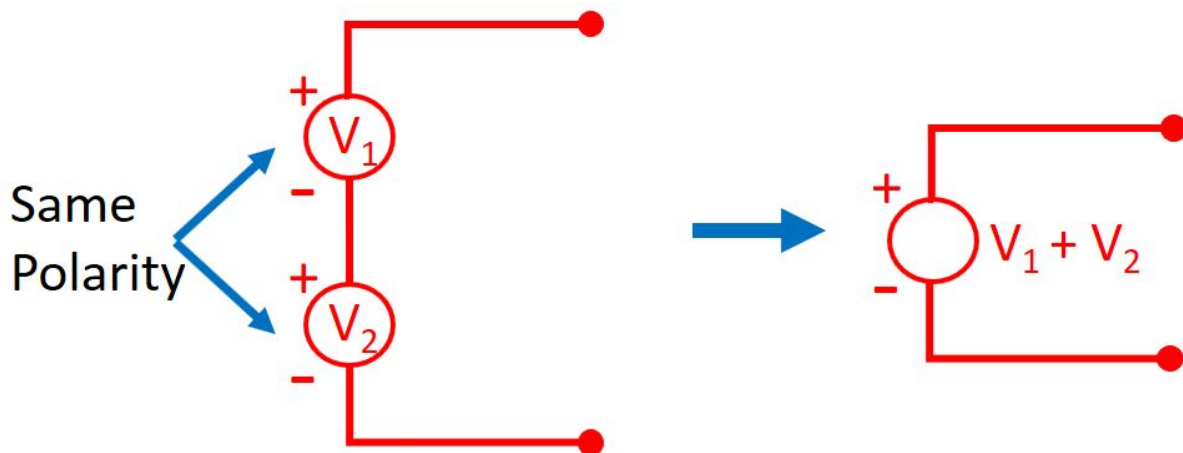

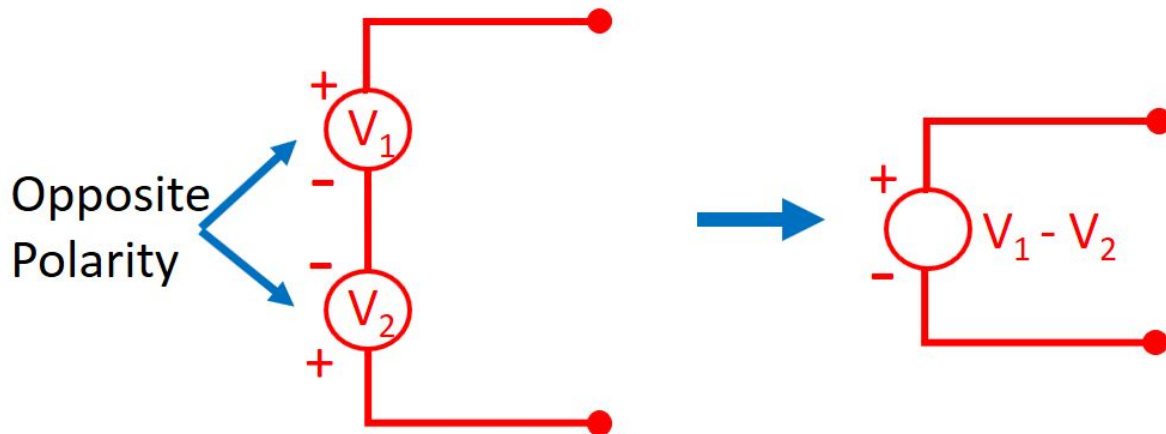

Unlike a series connection, any two Voltage sources can't be combined in parallel. Practically, only Voltage sources of the same magnitude are combined in parallel. If 2 unequal Voltage sources are connected in parallel, there will be a circulating current between them. Essentially what happens is that, the smaller voltage source is acting as a load for the larger voltage source. The magnitude of the current will depend on the value of the internal resistances of the 2 sources. Since the internal resistance is usually very small, a very large current flows, leading to overheating and possibly irreparable damage. Don't even think about connecting 2 ideal voltage sources in parallel, results could be catastrophic. And If you somehow manage to connect two voltage sources in parallel without damaging anything, the voltage across the combination will be somewhere between the 2 values depending on the internal resistances.

If 2 equal voltage sources are connected in parallel, the single equivalent source will have the same voltage as the 2 sources. The only reason to do this would be if the load requires a higher current than the source can supply by itself. Other than that, no good can come from connecting 2 voltage sources in parallel.

3.2.1 Combination of Current sources

Connecting two Current sources in series is a bit like connecting two Voltage sources in parallel. It's simply not a good idea. There are very few cases where such connection is required in practice, but that's a rarity. In any case only 2 current sources of same magnitude are connected in series. The magnitude of single equivalent source will supply the same current as the individual sources. Connecting 2 different Current sources in series is a violation of the Kirchhoff's current law. Again, you don't want to be messing with Kirchhoff!! The problem with connecting 2 unequal current sources in series is that, you are asking the small current source to supply more than what it is capable of. Intuitively, this means one source is trying to push more charge than the other source is capable of accepting.

If two current sources are connected in parallel, the effective current output of the combination is their algebraic sum. If the sources are in opposite direction, then the single equivalent source will produce current in the direction of the larger current source.

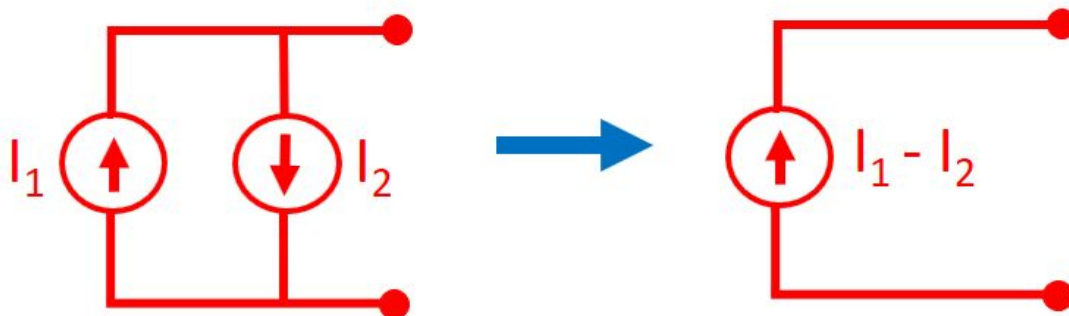
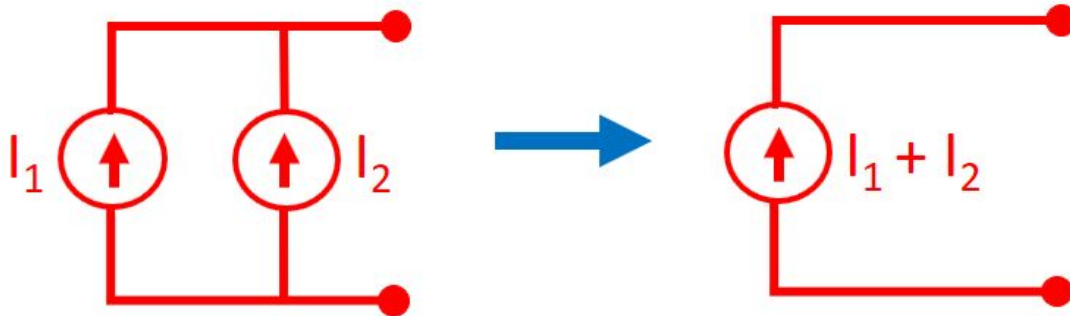

3.3 SOURCE TRANSFORMATION

In some circuits, you will encounter the presence of both current and voltage sources. This makes things a little trickier. Lucky for us, it is possible to convert one type of source to other type and it's pretty straightforward.

Consider a voltage source having an internal resistance R_{se} connected to a load resistor R_L . Now consider a current source having an internal resistance R_{sh} supplying the same load. If the two supplies were to be equivalent, then the load current (or voltage) should be the same in both cases.



The current delivered by the voltage source is given by,

$$I = \frac{V_1}{R_{se} + R_L}$$

And the current delivered by the current source (applying current division rule) is given by,

$$I = I_1 \times \frac{R_{sh}}{R_{sh} + R_L}$$

Equating both equations,

$$\frac{V_1}{R_{se} + R_L} = I_1 \times \frac{R_{sh}}{R_{sh} + R_L}$$

Now if we equate the numerators and denominators separately, we get,

$$\begin{aligned} R_{se} &= R_{sh} \\ &\& \\ V_1 &= I_1 R_{sh} \end{aligned}$$

Once the sources are transformed into same kind, they can be easily combined in series or parallel, as we did in the previous section.

3.4 MESH ANALYSIS

Using Circuit analysis techniques, we are essentially trying to find the voltage across or current through a component in a circuit. Two of the most popular and basic analysis techniques are the Node and the Mesh analysis. These techniques were developed as an extension to the KVL and KCL. We'll learn about Mesh analysis in this section & Node analysis in the next.

In mesh analysis, we are dividing the circuit into areas or loops called Meshes and assigning them a Mesh current. Consider the circuit below, just from observation, we can identify 3 loops or meshes. Do note that, these loops have some common components. Now assume a loop current to flow in each of these loops and give them a random direction (although normally we assume clockwise direction as in the figure).

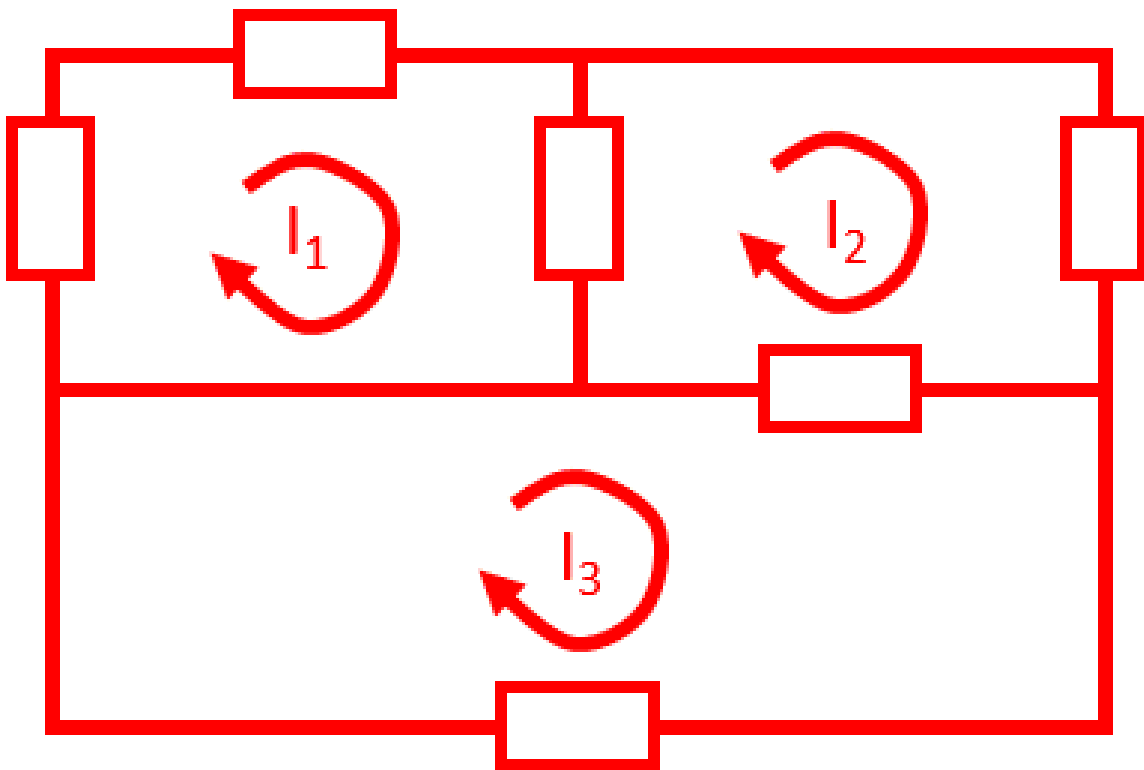

At first glance, this may seem like extra work, but it's worth it, because reduces the no. of equations significantly, making calculation very easy. Now let's try out an example.

Consider the circuit below, it has 2 voltage sources and a bunch of resistors. Simply through observation, we can identify 3 meshes. Let's assume currents I_A , I_B , I_C flow through the 3 meshes respectively.

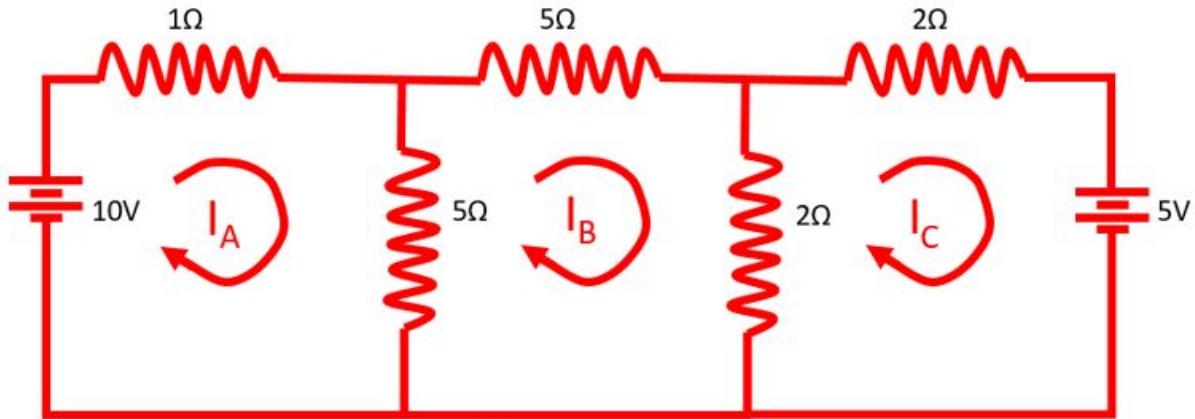

Now let's consider each mesh separately and form equations using KVL. Do note that the 5Ω resistor is common to both meshes A and B, so the current through it is the difference of the two mesh currents (because the currents are in opposite direction w.r.t 5Ω resistor.)

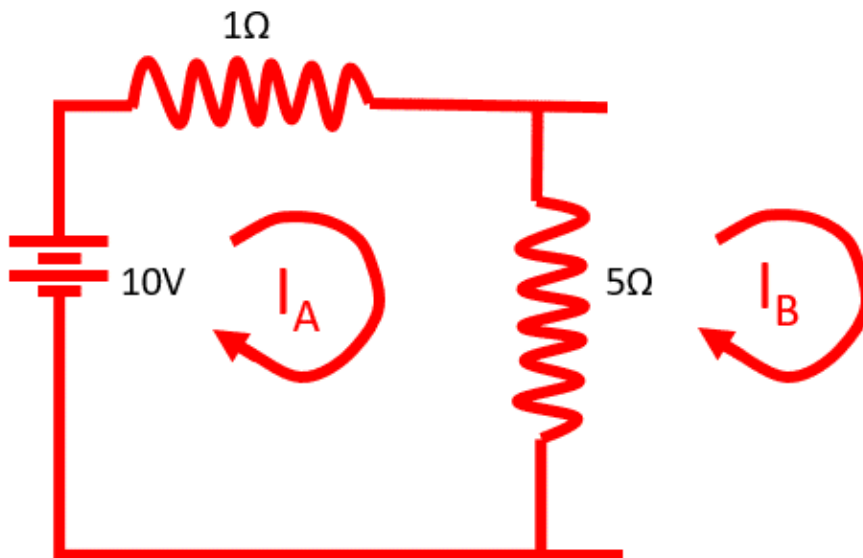

$$I_A + 5(I_A - I_B) = 10$$

$$\Rightarrow 6I_A - 5I_B = 10$$

Similarly we form equation for the other two meshes.

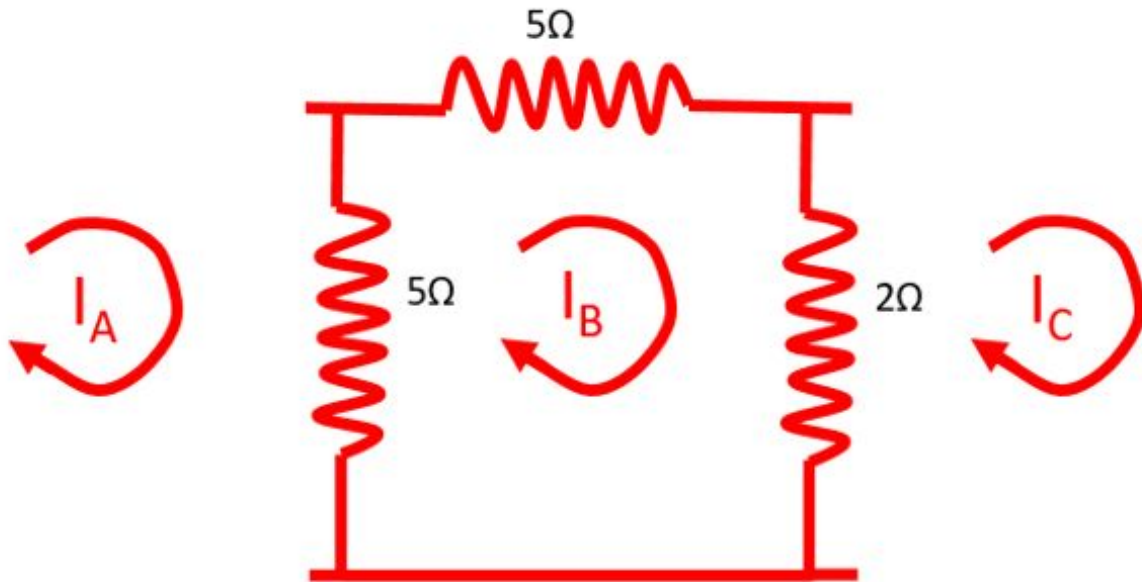

$$5I_B + 2(I_B - I_C) + 5(I_B - I_A) = 0$$
$$\Rightarrow 12I_B - 5I_A - 2I_C = 0$$

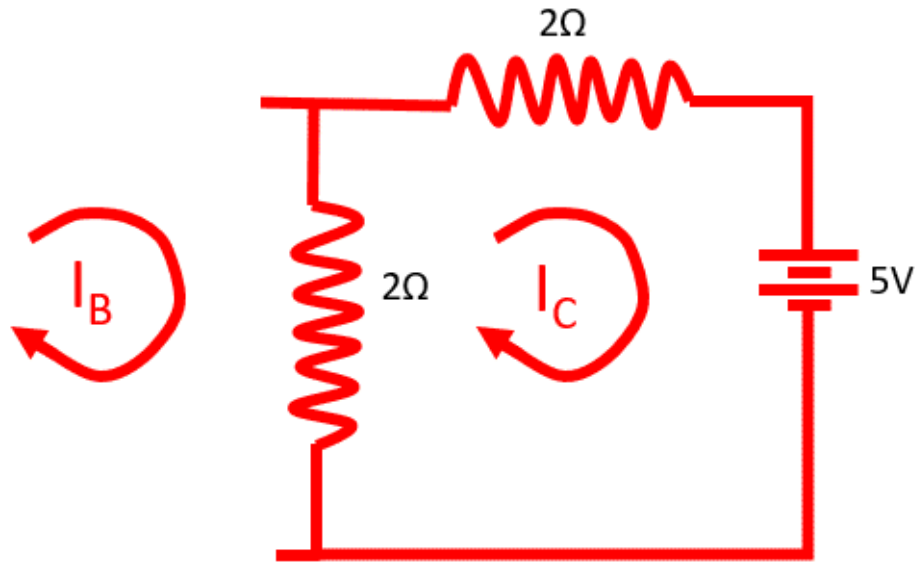

$$2I_C + 2(I_C - I_B) = -5$$

$$\Rightarrow 4I_C - 2I_B = -5$$

Now we have 3 unknown variables I_A , I_B , I_C and 3 equations. This can be easily solved using the Cramer's rule or by substitution.

3.5 SUPER MESH

Mesh analysis is all well and good, but what if a current source is present in the circuit?? We could assign an unknown voltage across the current source, apply KVL around each mesh as before, and then relate the source current to the assigned mesh currents. This is generally the more difficult approach. The easier method is to create something called the Super Mesh. Super Mesh is basically a mesh formed by combining 2 adjacent meshes, ignoring the branch which contains the current source.

For example, in the circuit below, we create a Super Mesh by combining meshes A and B. The Super Mesh equation can be obtained by applying

KVL to the super mesh, ignoring the common branch (that contains the current source).

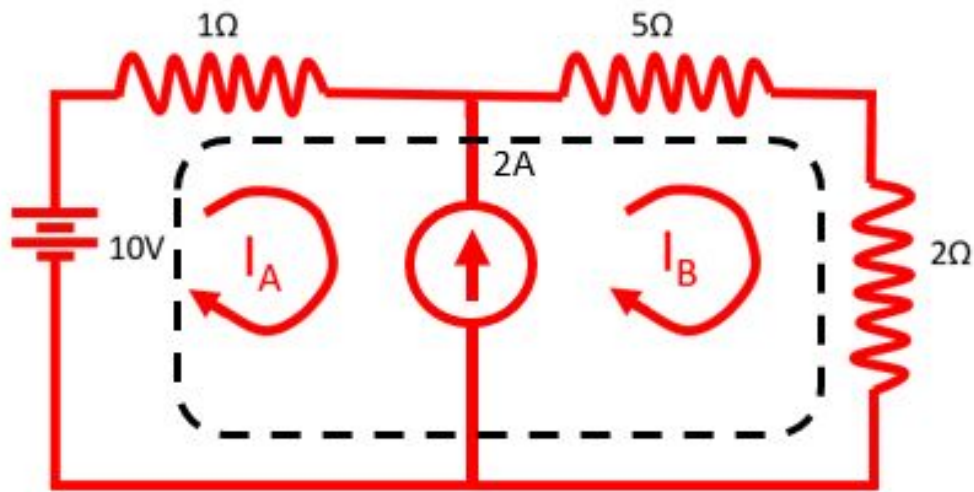

$$I_A + 5I_B + 2I_B = 10$$
$$\Rightarrow I_A + 7I_B = 10$$

The second equation relating the 2 mesh currents can be obtained by applying KCL to the common branch. In our example, it is,

$$I_B - I_A = 2$$

3.6 NODAL ANALYSIS

Much like the Mesh analysis, Nodal analysis is another commonly used circuit analysis technique. The Nodal analysis is based on KCL, whereas Mesh analysis is based on KVL. Before we go any further, we need to define a node. A Node is simply a point where two or more circuit elements meet. Let's try using Nodal analysis in practice. We'll use the same circuit we used in Mesh analysis example to get a better understanding between the similarities and differences between the two techniques.

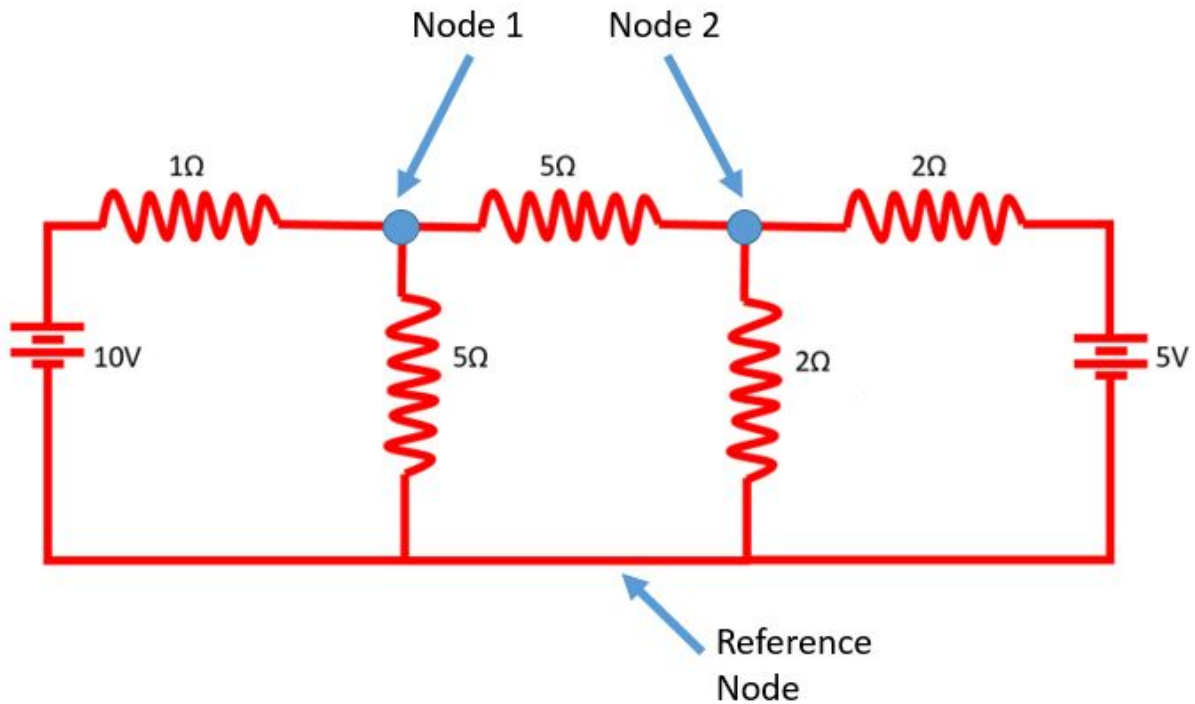

The first task in Nodal analysis is to identify the nodes in the circuit. Do note that, in Nodal analysis, we are only interested in nodes where 3 or more components meet. If we were to consider all the nodes, the method will still work, but the number of steps will increase. In our example, we can identify 3 such nodes. The next step is to assume one of those nodes as a reference node (usually the bottom one is chosen). The idea is assume zero voltage/potential at a point (Reference Node) in the circuit, so that we can measure/calculate voltage at different points with respect to this reference point. Once the Reference node is fixed, assume voltages at the other nodes (V_1 , V_2 , V_3 etc.). Once these things are taken care of, it's time to look at the nodes separately and form node equations.

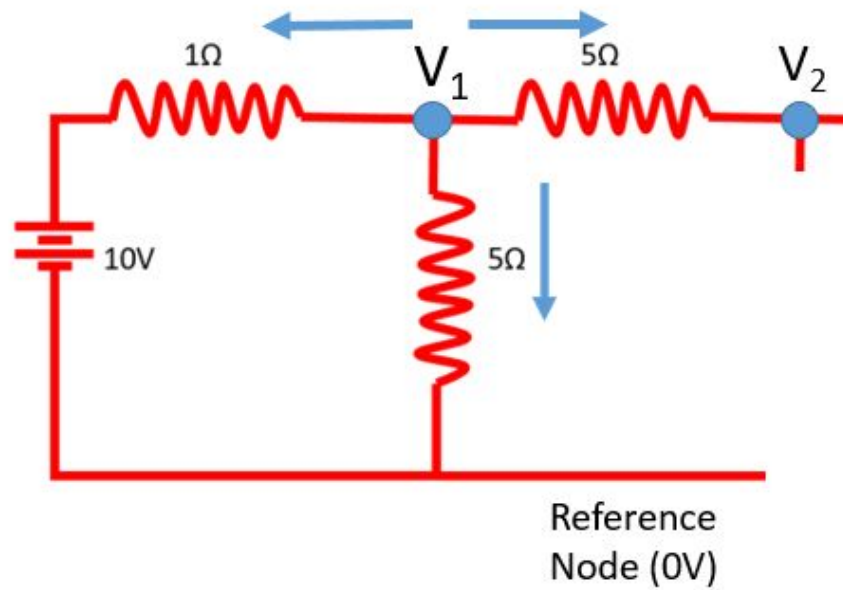

Applying KCL at Node 1,

$$\frac{V_1 - 10}{1} + \frac{V_1}{5} + \frac{V_1 - V_2}{5} = 0$$

$$\Rightarrow 6V_1 - V_2 - 50 = 0$$

Similarly applying KCL at Node 2,

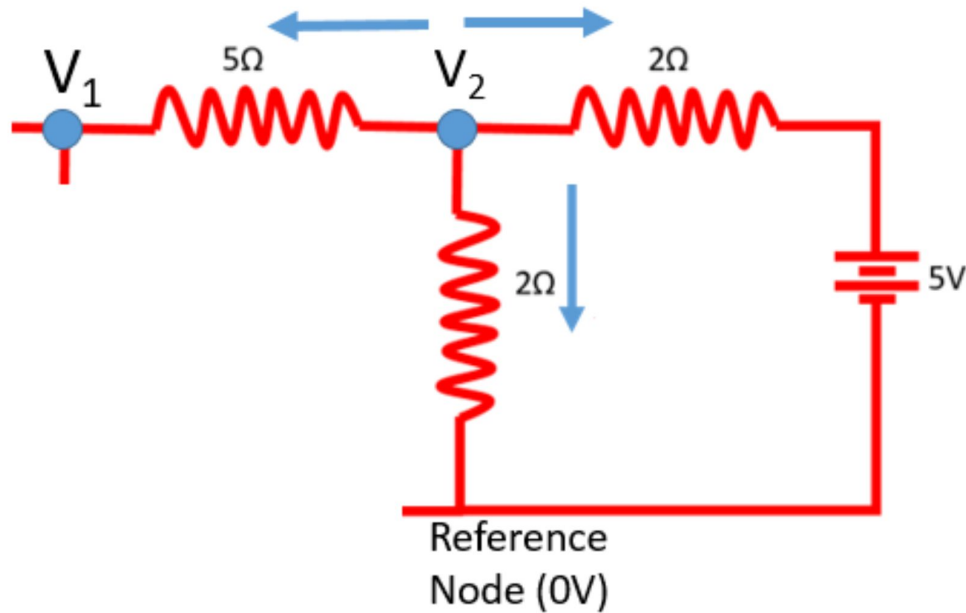

$$\frac{V_2}{2} + \frac{V_2 - 5}{2} + \frac{V_2 - V_1}{5} = 0$$

$$\Rightarrow 12V_2 - 2V_1 - 25 = 0$$

Solving these equations, we can obtain the node voltages and the rest of the parameters.

3.7 SUPER NODE

In some circuits, a voltage source may be present between 2 nodes. To deal with such circuits it's best to use the Super Node analysis. The first step is the same, to identify nodes and assign nodal voltages. Once that is done, we need to create something called the super node, by combining the 2 nodes ignoring the voltage source in between them. Then to obtain the super node equation, KCL is applied to both the nodes at the same time. The current through the common branch can be ignored, because the current exiting

node 1 and the current entering node 2 are the same and hence they cancel out when taking the combined KCL equation.

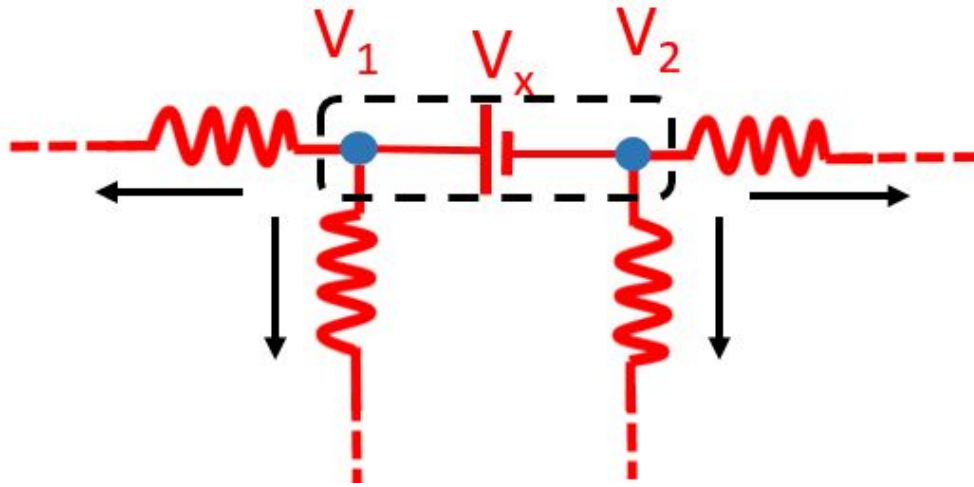

The second equation connecting the 2 nodes can be obtained by equating the difference between the 2 node voltages to the voltage of the source i.e. $V_1 - V_2 = V_x$. All the other nodes can be treated as before and corresponding node equations can be found.

4. NETWORK THEOREMS

While the circuit analysis techniques discussed so far, are very handy for simple circuits. They aren't are the preferred choice for more complex circuits. For that we need the help of some theorems. The idea is to use one or more of these theorems to convert the complex circuit into a simple equivalent, which can be easily analyzed using our familiar basic analysis techniques. Let's look at these Theorems one by one in detail.

4.1 SUPERPOSITION THEOREM

Analysis of circuits having multiple energy sources is not the easiest of tasks, but Superposition theorem provides an easy solution to this. According to the Superposition theorem, **the effect or response in a component when 2 or more energy sources (voltage or current sources) are applied together is equal to the sum of effect/responses when the sources are applied individually.** This may seem complicated, but that's just the statement, the application is very easy.

What the Superposition theorem really does, is to convert a circuit with n energy sources into n circuits with a single energy source acting individually, so that they can be analyzed individually and the results can be added up. To study the effects of one particular energy source on the circuit, the other sources need to be eliminated. This can be done by Short Circuiting the Voltage sources and Open circuiting the Current sources, which are not under consideration.

Now let's try and use the Superposition theorem in practice with the help of an example. In the circuit shown below there are 2 energy sources, one

current and one voltage source and suppose we need to find the voltage across resistance R_2 .

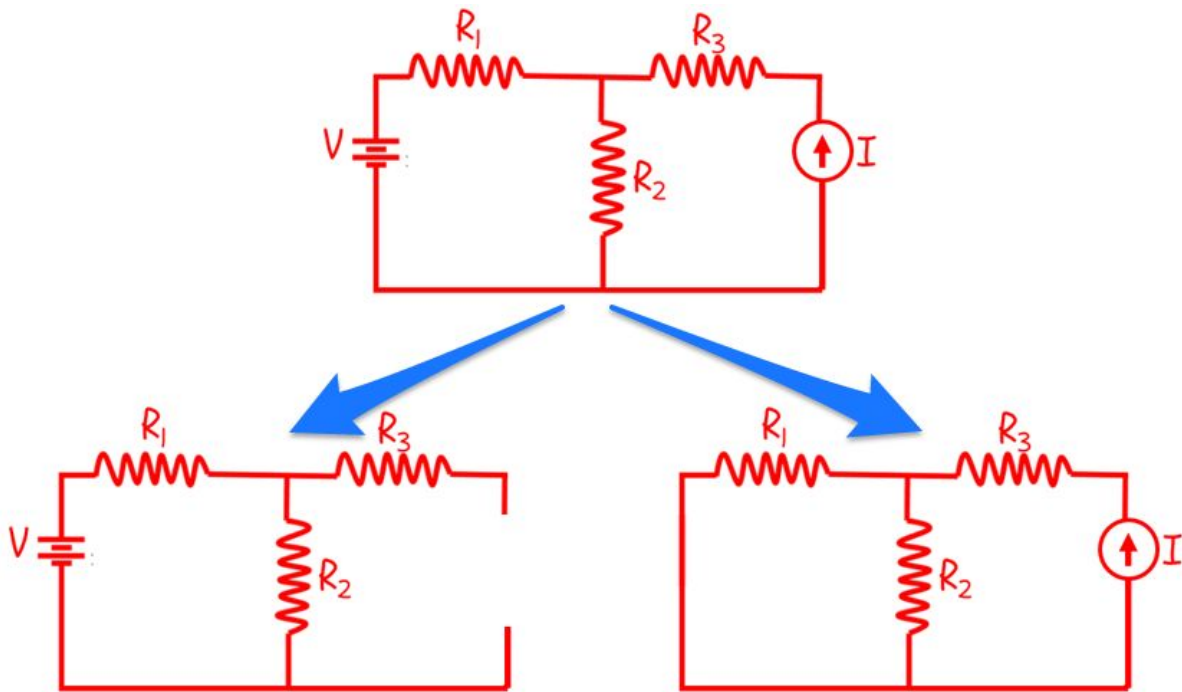

1. First thing to do is to split up the circuit into 2 circuits with a single energy source, as shown above.
2. In the first circuit, as the current source is open circuited, the branch containing resistance R_3 is no longer relevant. By using the voltage divider rule, the voltage across Resistor R_2 can be found as,

$$V_{R_2}' = \frac{V}{R_1 + R_2} R_2$$

3. In the second circuit, the voltage across R_2 can be determined with the help of the current division rule.

$$V_{R_2}'' = \frac{R_1 R_2}{R_1 + R_2} I$$

4. Once these results have been calculated, all you to do is to combine these results together, to find the voltage across the resistor R_2 due to the both sources acting simultaneously.

$$V_{R2} = V_{R2}' + V_{R2}''$$

4.2 THEVENIN'S THEOREM

In circuit analysis, we often encounter large circuits and most times we are interested only in a portion of the circuit, and not the circuit as a whole. In such cases, the analysis is cumbersome and the possibility of making errors is very high. Lucky for us, French engineer [Léon Charles Thevenin](#) found a solution. It's what's known as the Thevenin's Theorem.

According to the Thevenin's theorem, **any two-terminal, dc network can be replaced by an equivalent circuit consisting of a voltage source and a series resistor.**

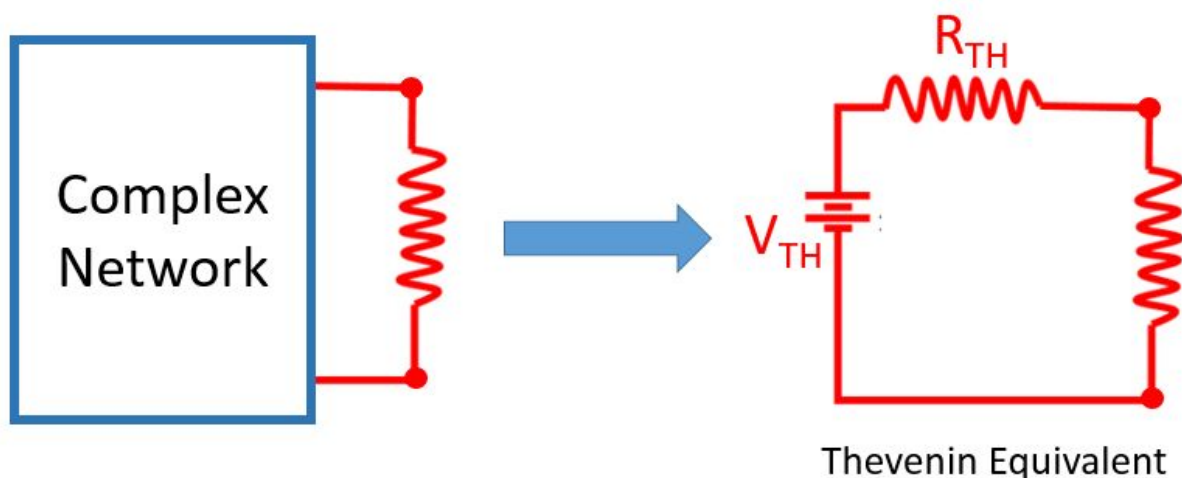

V_{th} is called the Thevenin equivalent voltage and R_{th} is called the Thevenin equivalent resistance. The Thevenin's theorem enables us to replace a large

part of a circuit, often a complicated and uninteresting part, with a very simple equivalent.

With the help of an example, let's see the Thevenin's theorem in action. (We have used a simple circuit for better understanding.)

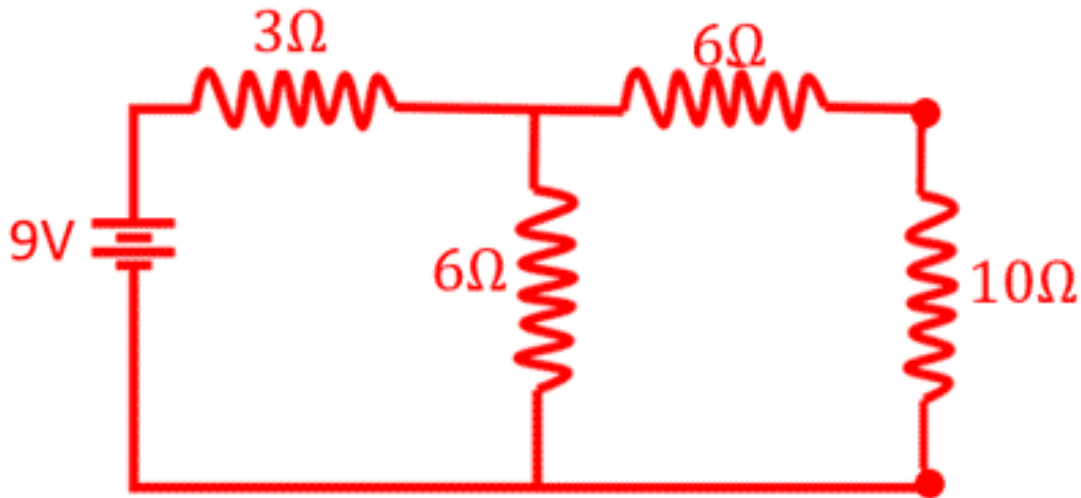

In the circuit shown above, let's try to find the current through the 10Ω resistor.

1. Firstly identify the part of the circuit, whose equivalent you want to determine. In this case it's everything except the 10Ω resistor.
2. Then temporarily remove the load resistor (10Ω) resistor from the circuit.
3. To find the Thevenin equivalent Resistance (R_{TH}), remove all the energy sources in the circuit. This can be done by short circuiting the voltage sources and open circuiting the current sources. In our example, there is one voltage source, short it out.

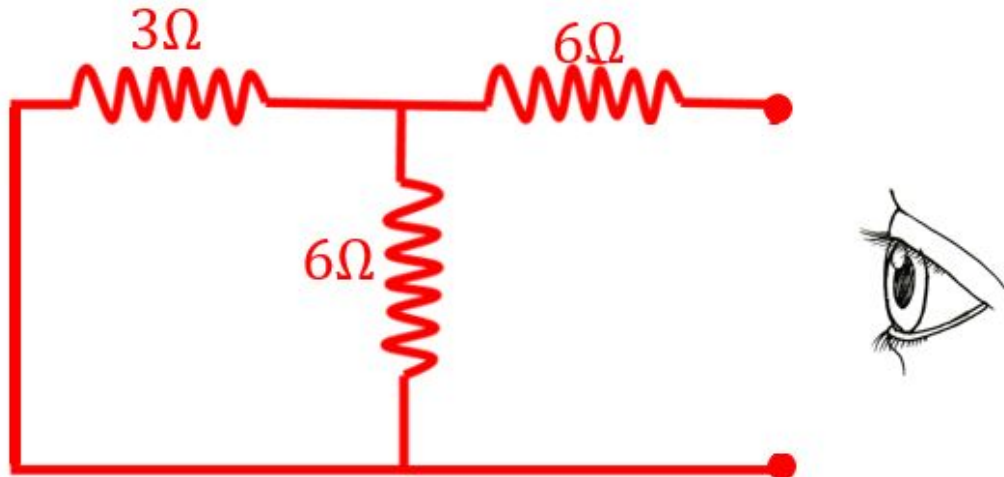

4. Now find the equivalent resistance between the terminals i.e. as if we were looking from the terminals. This will give the value of R_{TH} . In our example, 3Ω resistor is in parallel with 6Ω resistor, which are in series with 6Ω. Therefore $R_{TH} = 8\Omega$ (do the math.)
5. To find the Thevenin equivalent Voltage (V_{TH}), return the energy sources to the way it was before, then determine the open circuit voltage across the terminals.

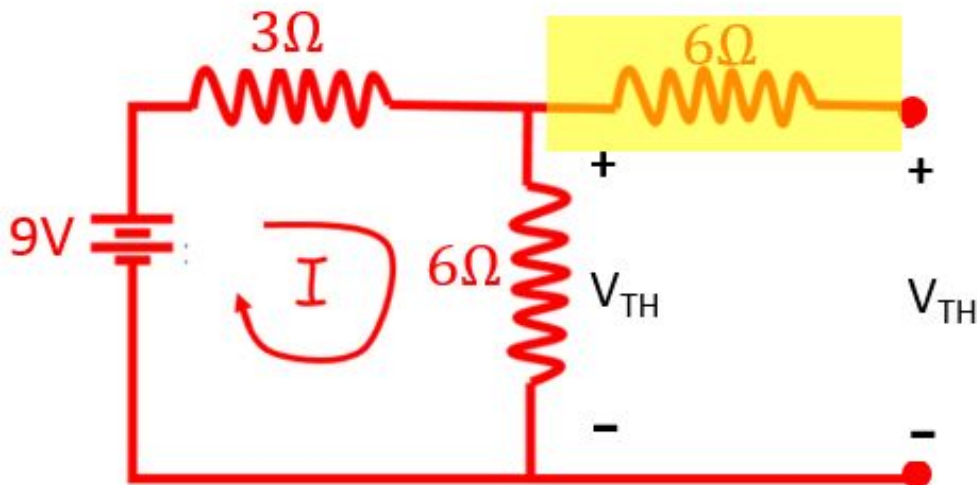

Do note that current cannot flow through the 6Ω resistor (highlighted) because the load resistance is open circuited and hence no voltage

drop across it. Therefore using Voltage Division rule, $V_{TH} = 6 \times 9 / (3+6) = 6V$.

6. Now that we obtained both R_{TH} and V_{TH} values, we are ready to put the load resistance back in its place and obtain the Thevenin equivalent circuit.

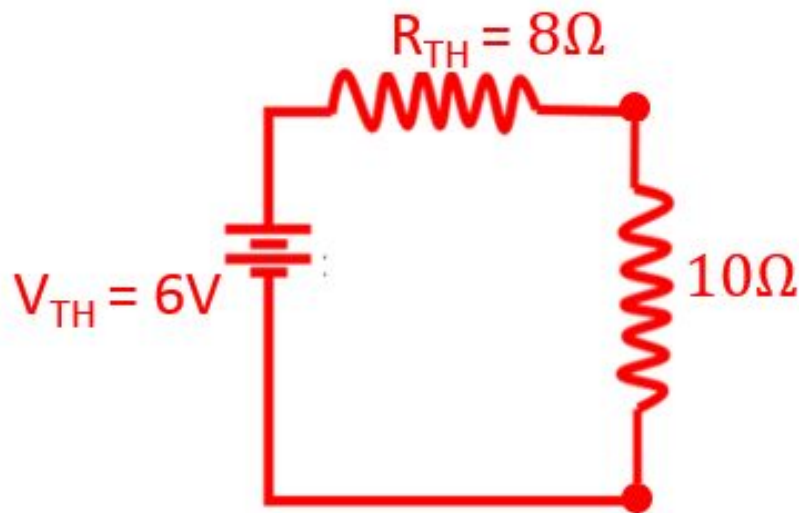

7. Now solving this circuit is a piece of cake. (Current through 10Ω resistor is 0.33 Amperes)

4.3 NORTON'S THEOREM

In the previous chapter we saw that it is possible to replace Voltage source by a Current source and vice versa. American engineer [E.L. Norton](#) made good use of this idea and theorized a corollary to the Thevenin's theorem called the Norton's theorem.

Norton's theorem states that, **any two-terminal, dc network can be replaced by an equivalent circuit consisting of a current source and a parallel resistor.**

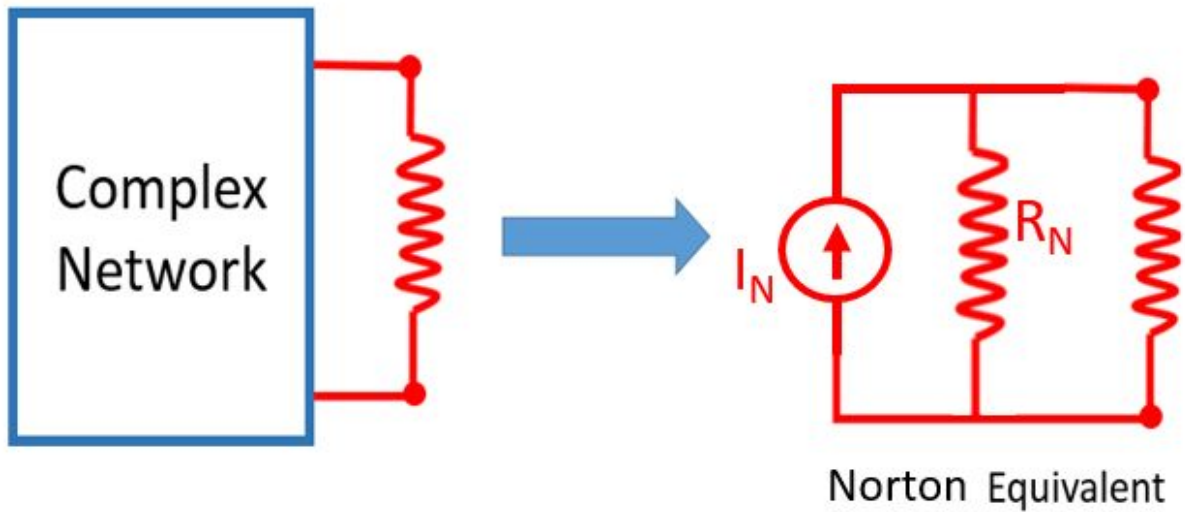

Now let's try the Norton's theorem on our example from previous section. Steps are as follows:

1. Firstly identify the part of the circuit, whose equivalent you want to determine and then temporarily remove the load resistor (10Ω) resistor from the circuit.
2. The Norton equivalent Resistance is the same as the Thevenin equivalent Resistance. So the procedure is the same, remove all the energy sources in the circuit and find the resistance between the load terminals. ($R_N = 8\Omega$).
3. To find the Norton equivalent Current (I_N), return the energy sources to the way it was before, then determine the short circuit current through the terminals. ($I_N = 0.25 \text{ A}$)

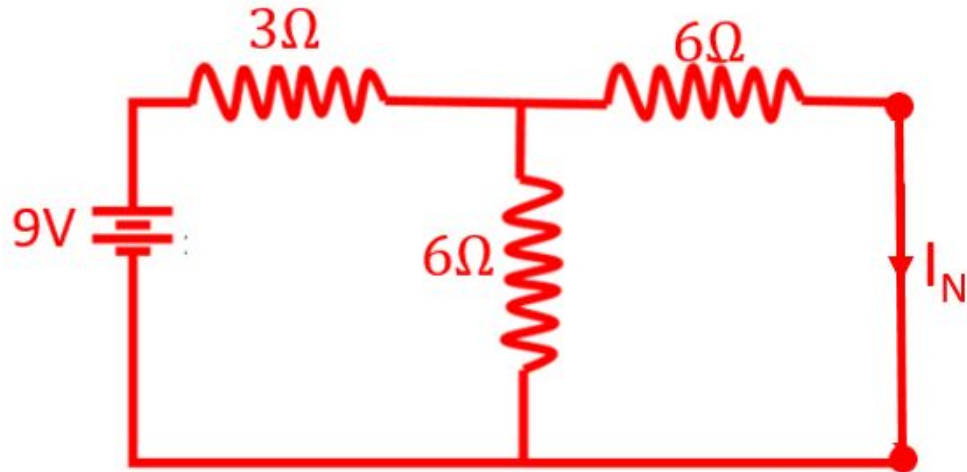

4. So the Norton's equivalent circuit is:

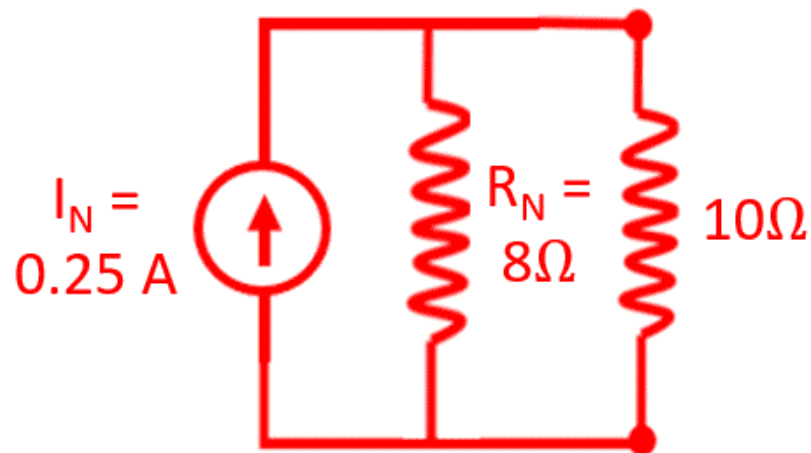

5. If you solve the circuit and the current through the $10\ \Omega$ resistor would be 0.333A , exactly same as obtained from Thevenin's theorem method.

We can easily switch between the two equivalent circuits simply by doing source transformation. In doing so we can also come up a relation between the 3 quantities R_{TH} , I_{N} and V_{TH} .

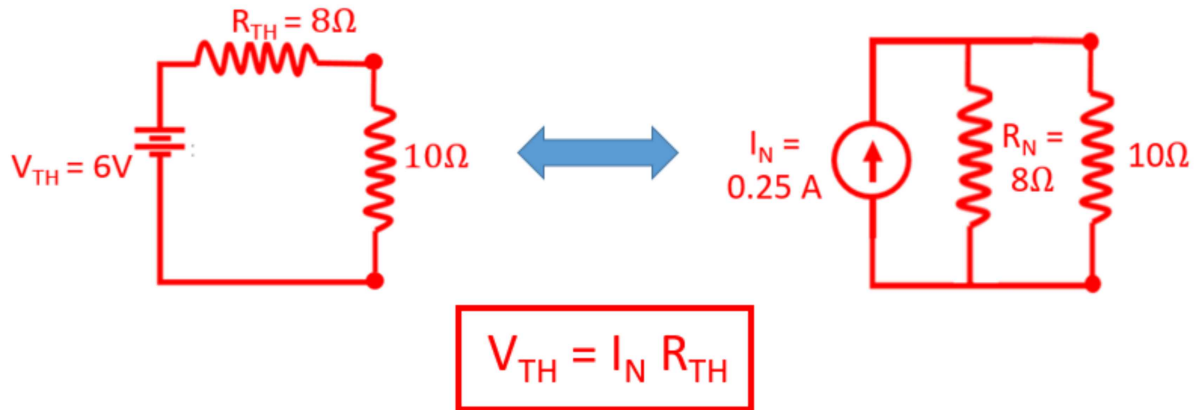

4.4 MAXIMUM POWER TRANSFER THEOREM

When we connect a load to a circuit, say a speaker to an amplifier circuit, it's only sensible that the maximum power should be delivered to the load. So how do we go about this?? Change the circuit to suit the load or change the load to suit the circuit?? Both are possible, but we can't randomly keep altering the components, we need to figure this out on paper. This is exactly what the Maximum Power Transfer theorem is there for.

According to the Maximum Power Transfer theorem, **the maximum power is delivered to the load, when the load resistance is equal to the Thevenin equivalent resistance of the circuit.**

First let's make sense of this intuitively, before we go into the mathematical proof.

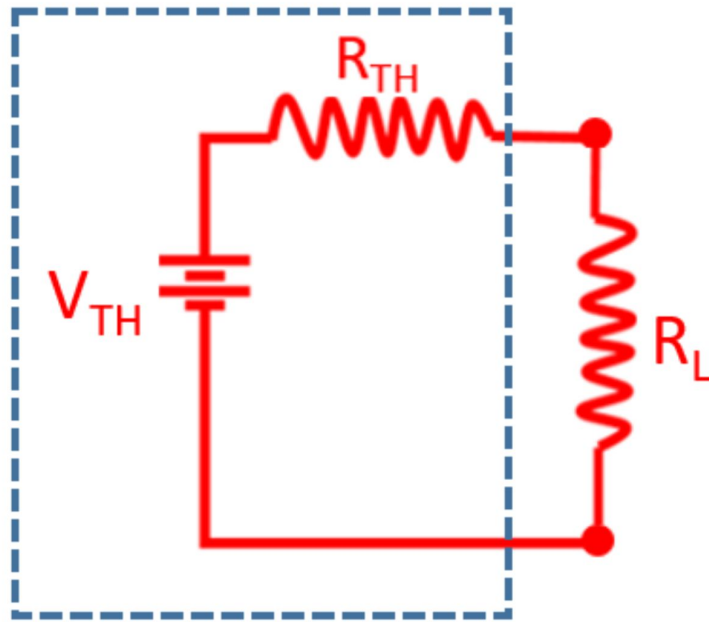

We know that power is the product of Voltage and Current, so for maximum power, both quantities need to be high. Say the load resistance is low, then the Current will be very high, but the Voltage will be equally low. Similarly, if the load resistance is high, then the Voltage will be high, but the Current though it will be very low. So clearly the extremes are not the way to go. At $R_L = R_{TH}$, both voltage and current will high enough to deliver maximum power. It's promising, but to confirm we need to use math.

$$I = \frac{E_{TH}}{R_{TH} + R_L}$$

$$P = I^2 R_L$$

$$\therefore P_L = \left(\frac{E_{TH}}{R_{TH} + R_L} \right)^2 R_L$$

To find the R_L corresponding to maximum power, P_L is differentiated with respect to R_L , keeping R_{TH} constant and equated to zero. If you actually bother to do the math, you can obtain the relation $R_L = R_{TH}$.

The Maximum Power Transfer theorem isn't a circuit analysis technique as such, but rather a practical application of the Thevenin and Norton theorems.

4.5 SUBSTITUTION THEOREM

According to the Substitution theorem, **any branch of a dc network can be replaced by a different combination of elements as long as the new combination of elements will maintain the same voltage across and current through, as the original branch.**

For example, consider this particular of a network, it has a voltage of 10V across it and a current of 2A flowing through it.

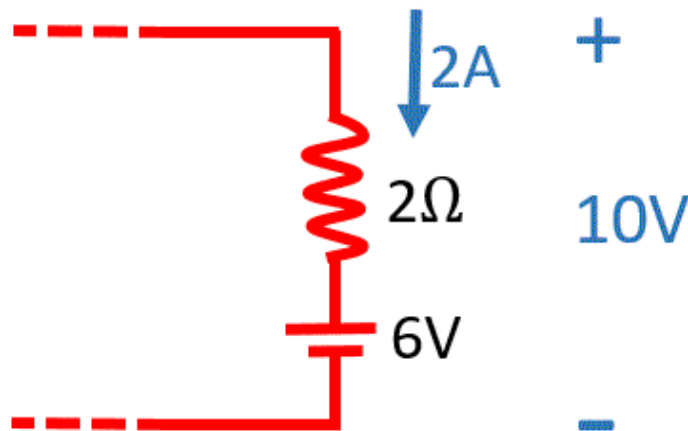

This branch can be replaced by any combination of elements as long as the voltage and the current remains the same. Shown below are some of the possible replacement combinations.

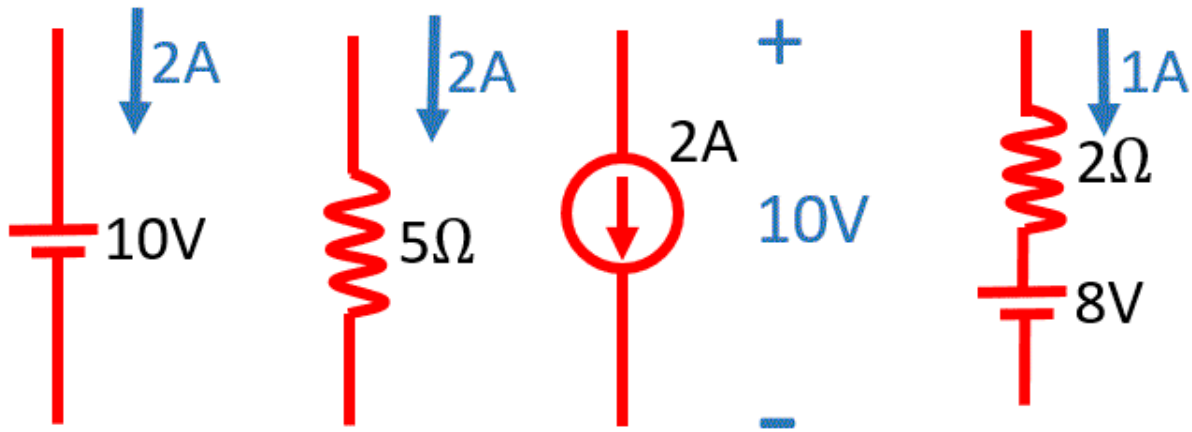

Substitution theorem gives you the ability to replace complicated branches of a circuit with convenient components to make circuit analysis simpler.

4.6 RECIPROCITY THEOREM

This is one of those nasty theorems, a bit hard to understand, and has limited application. But we are engineers and we don't have a choice but to learn. According to the Reciprocity theorem, **if a voltage source in a circuit causes a current in some other part of the circuit, then the positions of the voltage source and the resulting current can be interchanged without a change in the current.** There's no way that you can understand this theorem without the help of an example. Let's go step by step.

Consider this example, here the 10V voltage source causes a current I to flow through the $4\ \Omega$ resistor. If you do the math, you will get the magnitude of I as 0.45 A.

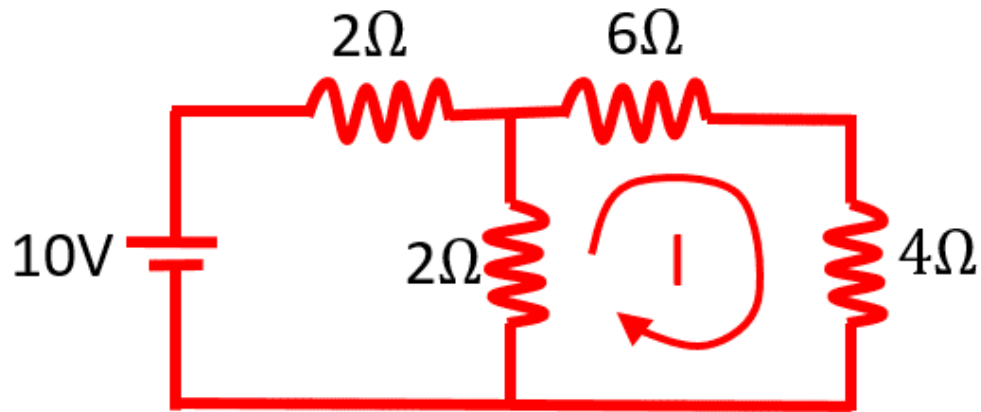

Now if you interchange the positions of the voltage source and the resultant current, you will get this circuit, shown below.

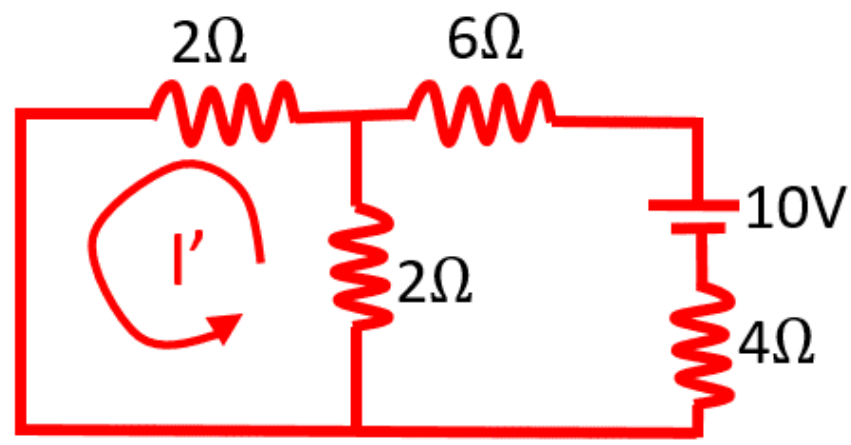

The 10V source will produce a current I' in its new position. Let's calculate it. We've used mesh analysis (but you are free to use anything) and we got 2 equations: $4I' - 2I_1 = 0$ and $-2I' + 12I_1 = 10$. Solving them, we get I' as 0.45A, which is the same as before. This is what the Reciprocity Theorem is. The ratio V/I is known as the transfer impedance.

Do keep in mind that the reciprocity theorem's use is strictly limited to single source circuits.

5. CAPACITANCE

5.1 CAPACITORS

A capacitor is an electrical device that is used to store electrical energy. Isn't that what batteries are for?? Yes...In a way, a capacitor is like a battery, they both store electrical energy. But the difference is in how they store energy and hence their applications differ. In a battery, chemical reactions produce electrons at one terminal and absorb electrons at the other terminal. Whereas, a capacitor is much simpler, it cannot produce new electrons, it only stores them.



Next to the resistor, the capacitor is the most commonly encountered component in electrical circuits. A capacitor is

constructed out of two metal plates, separated by an insulating material called dielectric. The plates are conductive and they are usually made of aluminum, tantalum or other metals, while the dielectric can be made out of any kind of insulating material such as paper, glass, ceramic or anything that obstructs the flow of the current. In fact, you can make a simple capacitor can be made from two strips of aluminum foil separated by two thin layers of wax paper (Check out this instructable : <http://www.instructables.com/id/Aluminum-Foil-Plate-Capacitor/>). Of course, our homemade capacitor won't work very well, but it shows capacitor like behavior nonetheless.

Since the plates are made of metal, they contain a huge no. of free electrons. In their normal state, the plates are neutral, as there is no excess or deficiency of electrons. But when we connect a power source to the metal plates of the capacitor, a current will try to flow i.e. the electrons from the plate connected to the positive lead of the battery will start moving to the plate connected to the negative lead of the battery. However, because of the dielectric between the plates, the electrons won't be able to pass through the capacitor, so they will start accumulating on the plate. After a certain number of electrons accumulated on the plate, the battery will not have the sufficient energy to push any new electrons. This leaves the top plate with a deficiency of electrons (i.e. positive charge) and the bottom plate with an excess of electrons (i.e. negative charge). In this state, the capacitor is said to be charged. This state will remain even after the battery is removed and the Capacitor will only discharge once a load is connected across it.

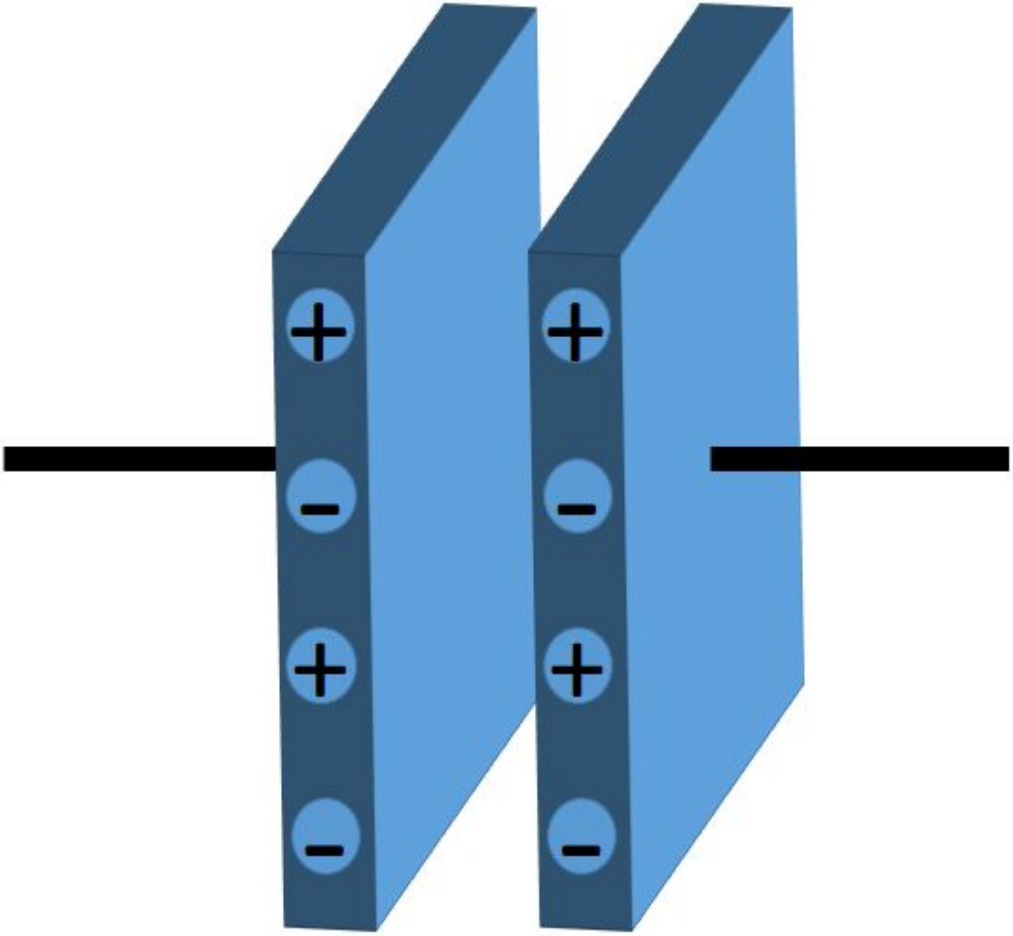

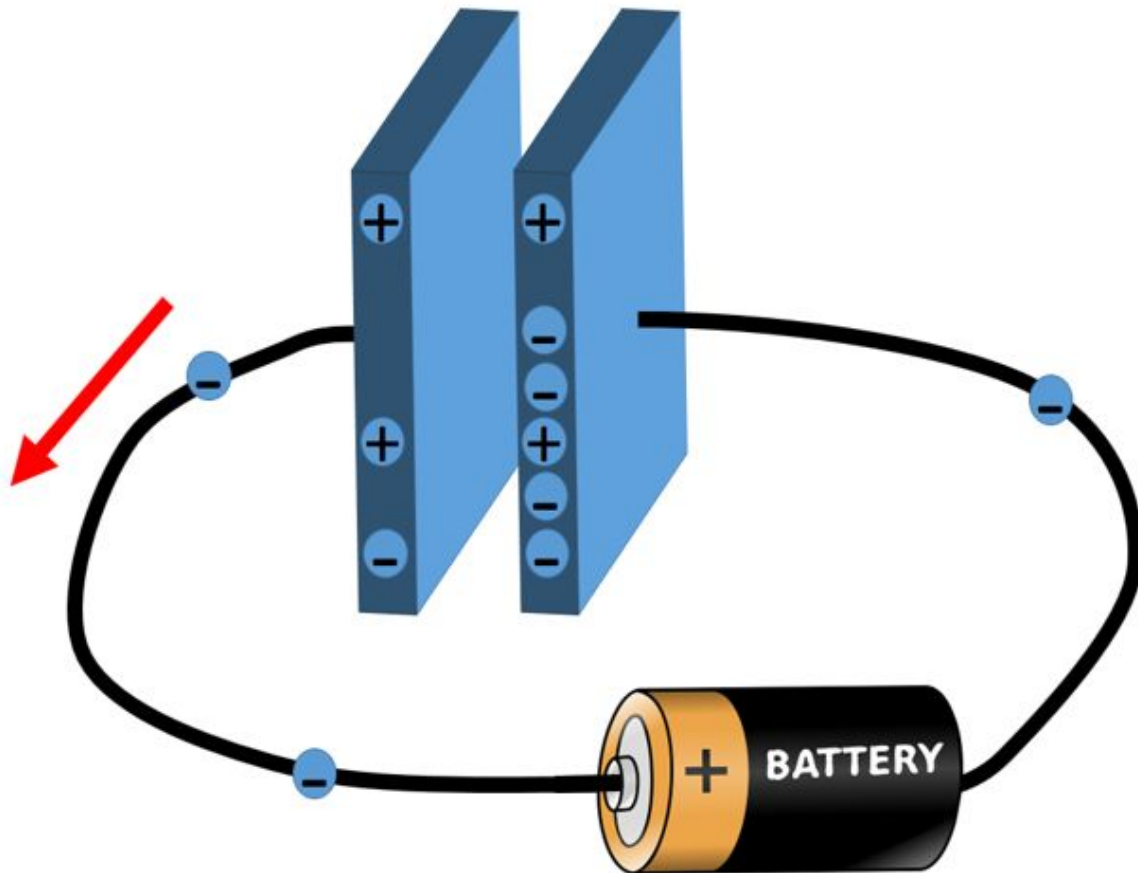

The ability of a capacitor to store an electric charge is referred to as its capacitance. The capacitance C is the ratio of charge stored Q to the potential difference V between the conductors. Mathematically,

$$C = \frac{Q}{V}$$

So a better capacitor would be the one able to store more charge for a particular voltage applied. Capacitance is measured in farads. This is a very large unit and hence most capacitors are rated in microfarads or less. The commonly used symbols for Capacitors are:

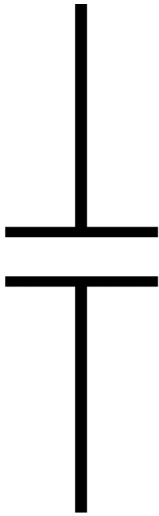

Fixed capacitor

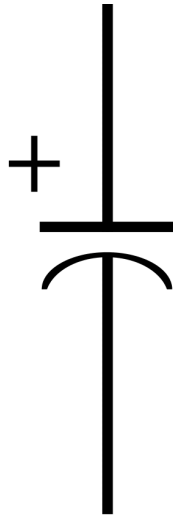

Polarized capacitor

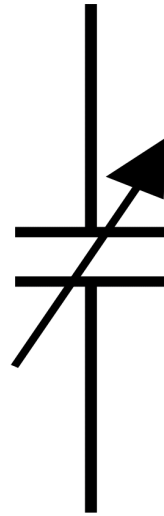

Variable capacitor

5.2 HYDRAULIC ANALOGY

A better understanding of how Capacitors store charge can be gained with the help of a hydraulic analogy. Consider the arrangement shown below, it consists of a water tank separated by a diaphragm D in the middle and a piston P to force water into either side of the diaphragm.

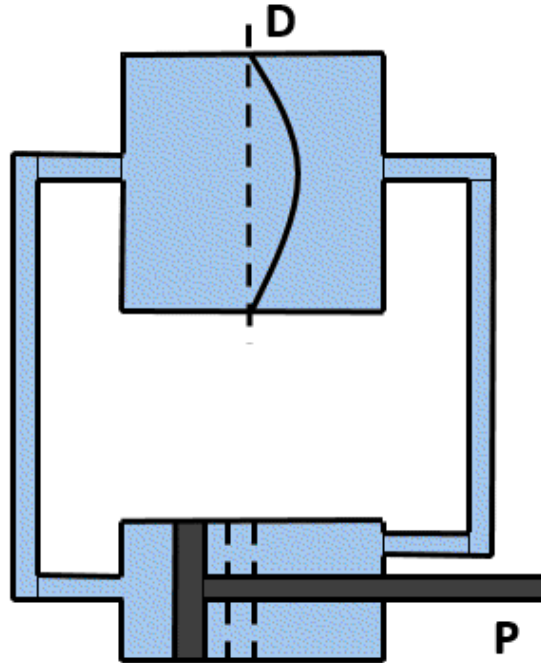

Under normal circumstance, when the piston is left untouched, the diaphragm is flat as shown by the dotted line. It's similar to an uncharged capacitor, it has no energy. But if the piston is pushed towards the left, water is drawn from the right side of the diaphragm and at the same time water is being forced into the left side. Under this condition the diaphragm is no longer flat, as shown by the full line. Greater the force applied to the piston, more water is displaced, and hence the diaphragm is under greater stress. The force applied to the piston is analogous to the EMF applied, and the water displaced to the charge displaced, in case of a capacitor. Just like the diaphragm separates the two halves of the tank and doesn't allow water from either side to mix, the dielectric separate the charge in a capacitor.

If we now remove the force on the piston, the diaphragm will try to release its stress (energy) by becoming flat, hence pushing the piston back to its original position. This is exactly what happens when a charged capacitor is connected to a load resistance. A current rushes through the resistance till the energy stored is released. The rate of flow of water is dependent on the resistance offered by the pipes, much like the rate of flow of charge (current) is dependent on the resistance offered by the wires.

The diaphragm will rupture if sufficient enough force is applied on the piston, just as the Capacitor will breakdown under excess voltage.

5.3 CAPACITORS IN PARALLEL

Like with resistors, capacitors can also be connected in series or parallel combination and to analyze such circuits, we can find equivalent capacitance for these combinations. When a set of capacitors are connected in parallel, the total equivalent capacitance is the sum of individual capacitances.

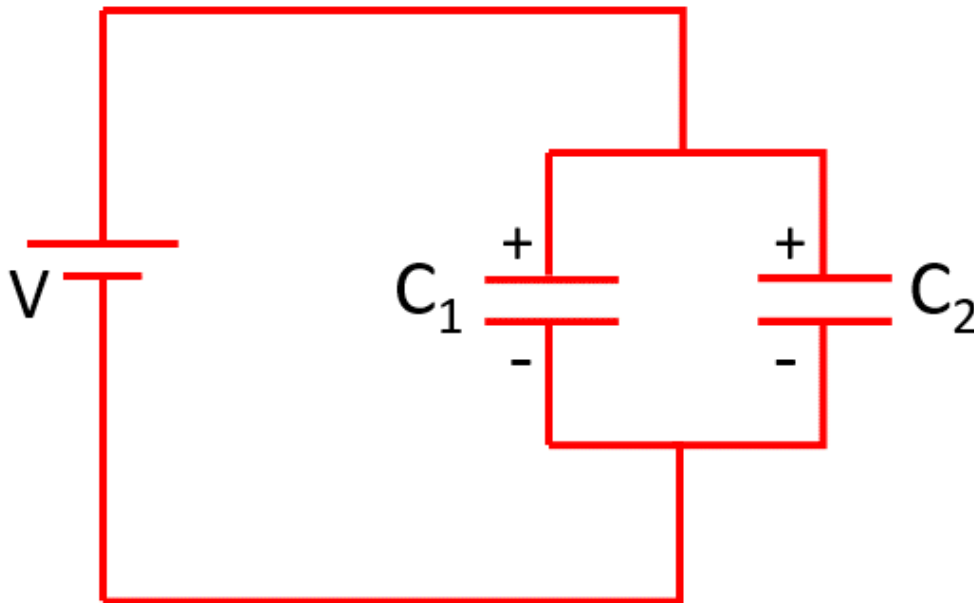

Suppose two capacitors, having capacitances C_1 and C_2 farads are connected in parallel across a potential difference of V volts. Let the charge on C_1 be Q_1 coulombs and that on C_2 be Q_2 coulombs, where.

$$Q_1 = C_1 V \quad \&$$
$$Q_2 = C_2 V$$

If we were to replace the capacitors by a single equivalent capacitor C , then a charge $Q = Q_1 + Q_2$ would be produced by the same potential difference.

$$Q = Q_1 + Q_2$$
$$\Rightarrow CV = C_1V + C_2V$$

$$\therefore C = C_1 + C_2$$

This result can be extended to any no. of capacitors connected in parallel. For 'n' capacitors in parallel,

$$C_{eq} = C_1 + C_2 + \dots + C_n$$

5.4 CAPACITORS IN SERIES

For a series combination of capacitors, the reciprocal of the equivalent capacitance is the sum of the reciprocals of the individual capacitances.

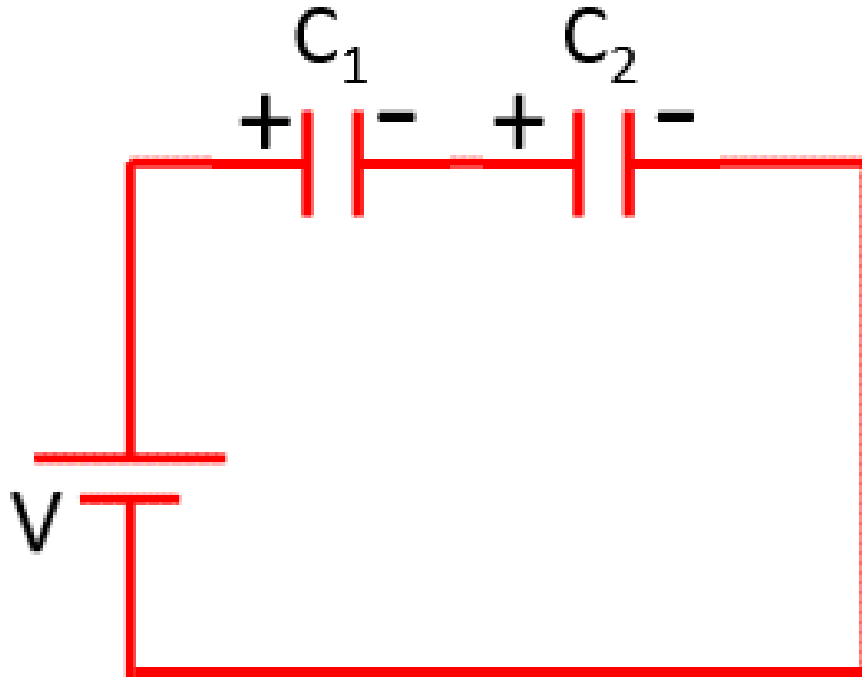

Suppose two capacitors, having capacitances C_1 and C_2 farads are connected in series across a potential difference of V volts. Let the voltages across C_1 and C_2 be V_1 and V_2 volts respectively. Obviously, because it's a series connection, the currents and hence the charge flowing through the capacitors are the same.

$$\therefore Q = C_1 V_1 = C_2 V_2$$

$$\Rightarrow V_1 = \frac{Q}{C_1} \text{ \& } V_2 = \frac{Q}{C_2}$$

Now if we were to replace the 2 capacitors with an equivalent capacitor of capacitance C , then it would have the same charge Q , when connected across the voltage V . Also from KVL, we know that $V = V_1 + V_2$.
Therefore,

$$V = \frac{Q}{C} = \frac{Q}{C_1} + \frac{Q}{C_2}$$

$$\Rightarrow \frac{1}{C} = \frac{1}{C_1} + \frac{1}{C_2}$$

This result can be extended to any no. of capacitors connected in series. For 'n' capacitors in series,

$$\frac{1}{C_{eq}} = \frac{1}{C_1} + \frac{1}{C_2} + \dots + \frac{1}{C_n}$$

Do note that the expression for capacitors in series and resistors in parallel are the same and similarly the expression for capacitors in parallel and resistors in series are also the same.

5.5 CHARGING & DISCHARGING OF A CAPACITOR

A Capacitor doesn't charge up all of a sudden, when connected to a voltage source. It takes some definite time for the capacitor to become fully charged and it does so in an exponential manner. When an uncharged capacitor is connected to a DC source, the voltage across is zero, as if there is a short circuit, then the voltage exponentially increases to the applied voltage after

a while. On the contrary, as soon the source is connected, the max current rushes to the capacitor. Later as the time passes, the current decreases to zero and acts like an open circuit. How fast the capacitor charges up depends on any resistance present in the circuit.

Charging of a Capacitor

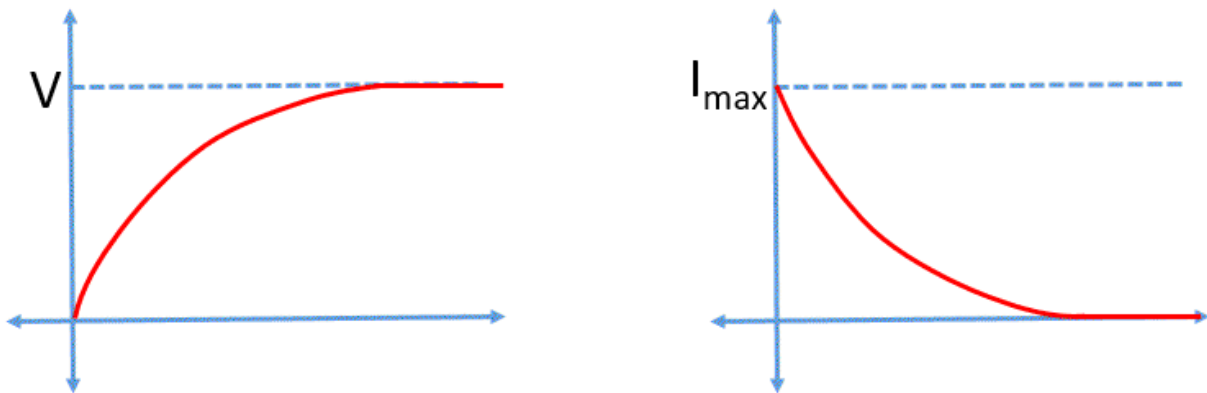

A fully charged capacitor will discharge in exactly the reverse manner, the voltage drops and the current picks up exponentially.

Discharging of a Capacitor

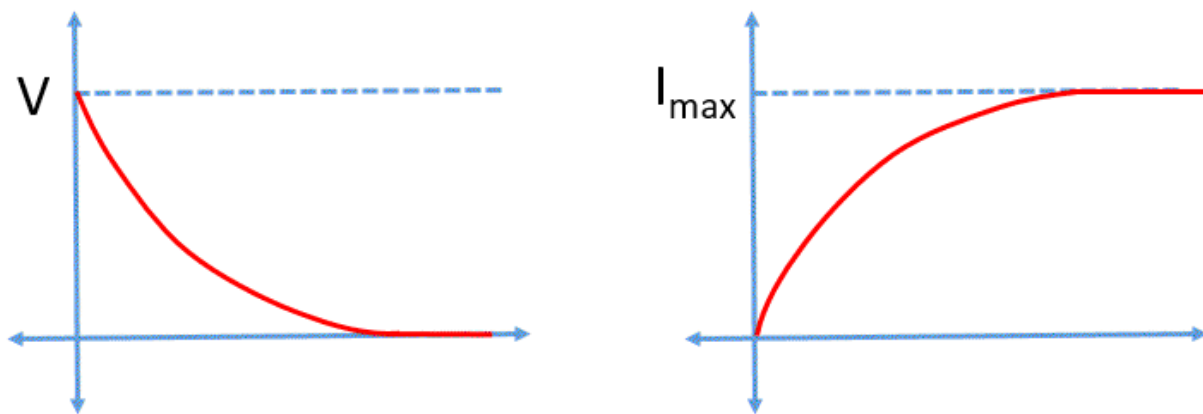

We'll study this in greater detail with the help of Laplace transform in chapter 12.

5.6 ENERGY STORED BY CAPACITORS

The energy stored in a Capacitor is basically the energy the battery expended in moving electrons from the positive plate to the negative plate of the capacitor against their natural tendency. Suppose a voltage V is applied to capacitor terminals, then the work done transferring an infinitesimal amount of charge dq from the negative to the positive plate is simply,

$$dW = V dq$$

The work done is a variable quantity, because as the charge accumulates, more work needs to be done in moving the electrons. Similarly, Voltage is also a function of charge. Hence the incremental work is given by,

$$V = \frac{q}{C}$$

$$\therefore dW = \frac{q dq}{C}$$

To find the total work done, we need to integrate this quantity from 0 to the maximum charge Q .

$$W = \int dW = \int_0^Q \frac{q \, dq}{C}$$

$$\therefore W = \frac{Q^2}{2C}$$

This expression has different forms, based on the quantities you choose:

$$W = \frac{Q^2}{2C} = \frac{CV^2}{2} = \frac{QV}{2}$$

6. INDUCTANCE

6.1 ELECTROMAGNETISM

Firstly, Electromagnetism is a huge topic and doesn't really have a place in a circuit analysis text. But since we want to give our readers a proper introduction to inductance, we will quickly go through the fundamental ideas in electromagnetism without going into the minute details.

The most fundamental idea in electromagnetism is that there is magnetic field surrounding every current carrying object. These magnetic fields take the shape of concentric rings around a straight wire, called magnetic field lines. Larger the current flowing through wire, more the no. of magnetic field lines. These lines are not random, they have direction, which can be determined by using the Right hand thumb rule. It goes like this, if you point your thumb in the direction of the current, then the fingers curl in the direction of the field lines

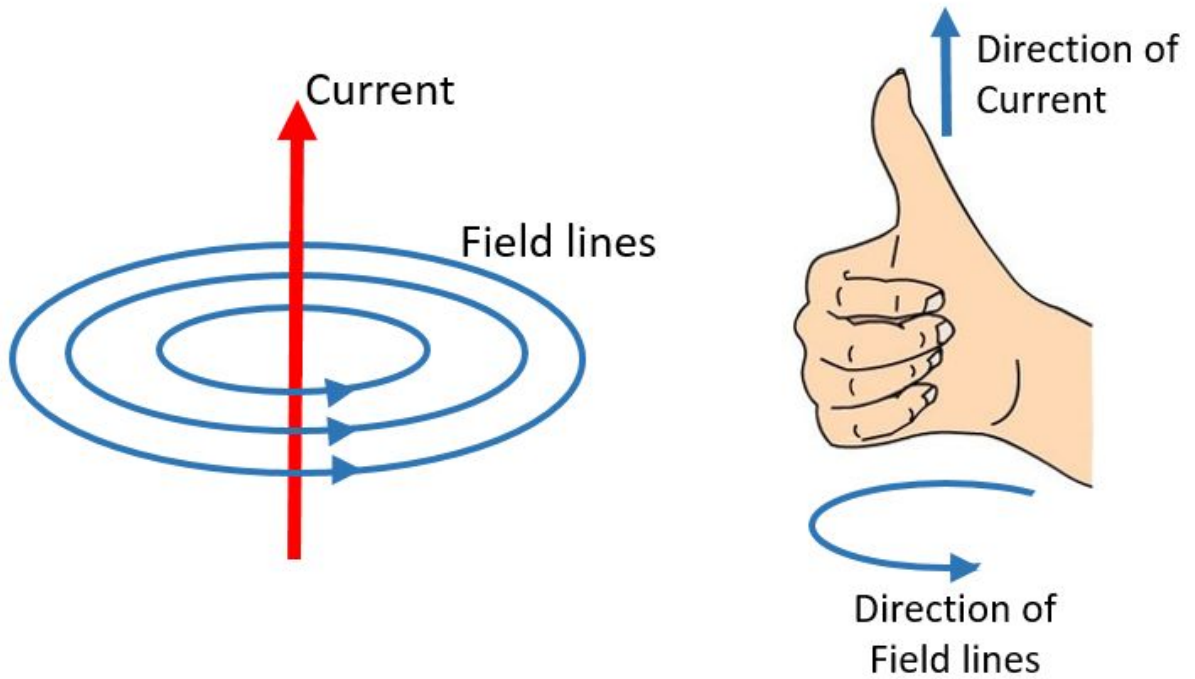

Similarly, when current flows through a coil, a magnetic field is generated, such that coil acts like a magnet with a north and south polarity. The pattern of field lines is as shown below. Do note that field lines are concentric if you consider a tiny portion of the coil, but these field lines add and cancel each other giving us this effective pattern. By the way these sort of coils are called Solenoids.

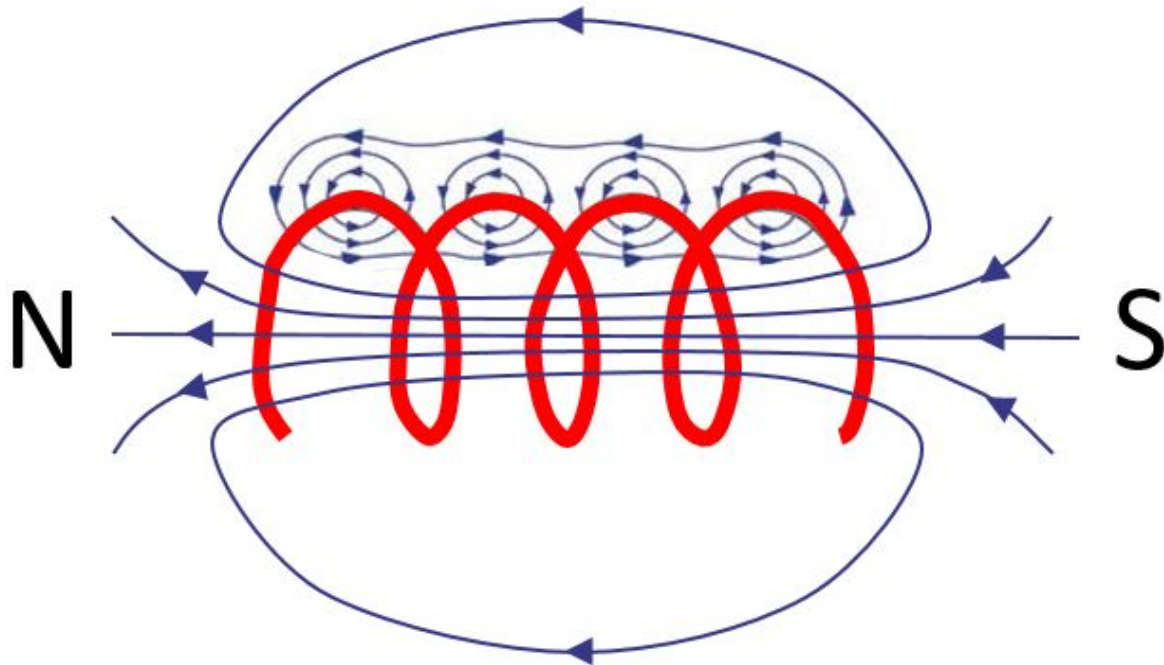

Faraday's Laws: Michael Faraday formulated 2 laws, which form the basis of Electromagnetic studies, called the Faraday's Laws. These laws introduces us to the phenomenon called Electromagnetic Induction.

According to the Faraday's first law, **when a conductor is placed in a varying magnetic field, an EMF gets induced across the conductor and if the conductor offers a closed circuit then induced current flows through it.**

And Faraday's second law states that, **the induced EMF is directly proportional to the rate of change of magnetic flux.**

If you place a bar magnet near a wire, nothing happens, no voltage is induced. But if you move the magnet such that some of the flux lines (imaginary) are cut by the wire, then a voltage is induced.

There are two ways to obtain varying magnetic field:

1. One is relative spatial movement that is, if the distance between the magnet and the conductor keeps changing, the magnetic field also keeps changing and induction is possible.

2. The other is to vary the magnetic field originating from the source itself. This is not possible with permanent magnets, but it's easy to do with solenoid magnets we discussed earlier. All you need to do is to vary the current through the coils, the magnetic field also varies as a result.

Guess what would happen if we placed 2 coils close to each other, one connected to a varying current source and the other to an ammeter? Yes, the ammeter will show deflection, proving that a current has been induced in the second coil.

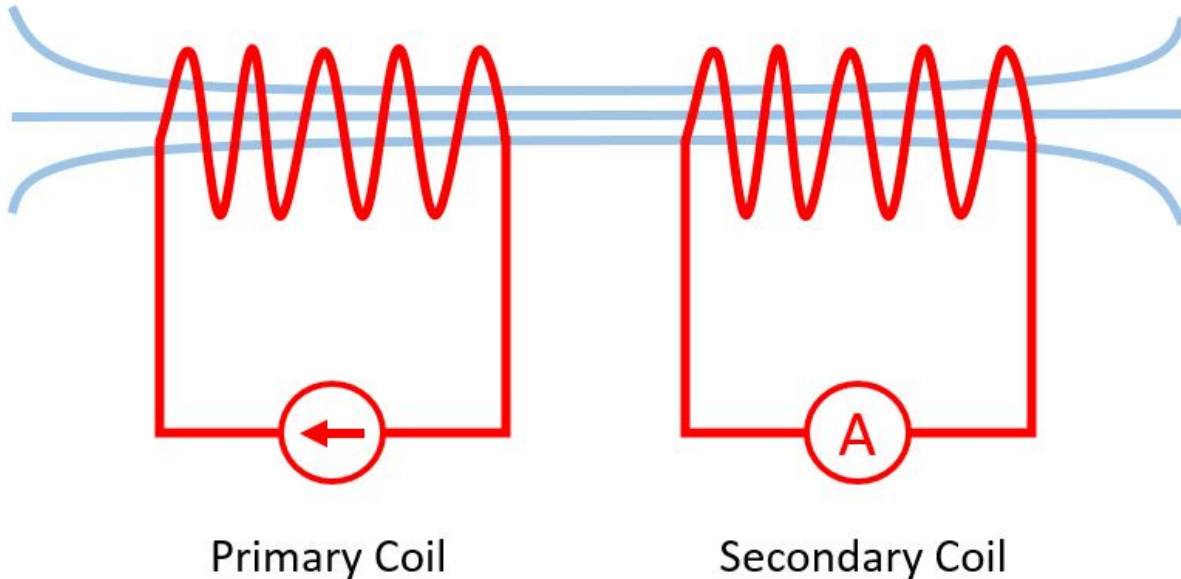

So can we just place many coils in the proximity of a current carrying coil and induce current in all of them? Yes, that's possible. Wait! Did we just invent a new method to generate electricity?? Unfortunately not, there's a catch in all this, called mutual induction. When we induce a current in the secondary coil, this current will produce itself produce a flux in the secondary coil. This flux will link with primary coil, inducing an EMF. So this is a mutual process. To sum up, the primary induces a voltage, therefore a current in the secondary, which in turn will induce a voltage and a current back in the primary.

The catch is that the current induced back in the primary will be in the opposite direction as the original applied current in the primary, thus reducing the overall effect. This isn't a wild theory or anything, it's a direct consequence of the law of conservation of energy. In electromagnetics it's called the Lenz's law. Lenz's Law ensures that the electrical energy of the primary coil is reduced by the same amount as the energy gained by the secondary coil. In layman's terms, an induced effect is always such as to oppose the cause that produced it.

Electromagnetic induction is the principle behind the working of devices like transformers, motors etc.

Now there's another type of Inductance called Self Inductance. We'll study about it in detail in the next section.

6.2 INDUCTOR

Inductor is the final member of our amazing trio that includes the resistor and the capacitor. Like the other two components, the inductor is practically used everywhere. Have you seen a copper coil in an electronic circuit?? That's the inductor, that's right it's just a coil, nothing else.



Inductor like the capacitor is an energy storing device, but it uses a completely different mechanism to do so. While the capacitor stores energy in the form of electrostatic energy, the inductor stores its energy in the form of magnetic energy. Despite this, Inductors aren't primarily used as a storage devices, they are commonly used as filters and chokes. That's because Inductors have the ability to suppress variation in current flowing through it.

The inductors ability to resist variation in current can be attributed to a phenomenon called Self Induction. The phenomenon can be better understood with the help of the figure below.

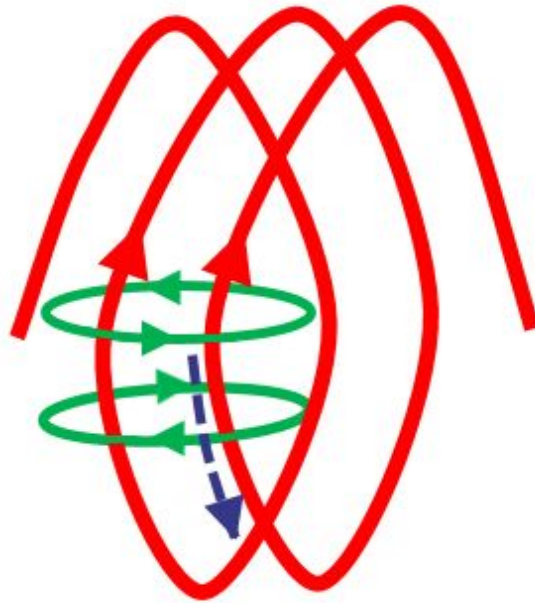

Consider just two loops of an inductor coil. When a current is passed through the inductor or more specifically the first loop of the inductor, it produces magnetic a field around it in a concentric manner (as with any other conductor). This magnetic field created by the first loop also links with the second loop, because of their proximity. The natural response of the second loop to this magnetic field, is to produce a current (or a counter magnetic field as represented by the bottom ring) such as to oppose the original current, in accordance with the Lenz's law. The direction of the current induced in the second loop due to the field generated by the first loop is show by the dotted arrow. These currents will be generated whenever there is a variation in current in the inductor and it opposes the original inductor current. So this ability of an Inductor to oppose change in current is called the Self Inductance or simply Inductance. It is denoted by the letter L and its unit is Henry (H).

Our analysis was just with 2 loops, but the inductance will increase if the number of winds in the coil is increased since the magnetic field from one coil will have more coils to interact with. So self-induction in a way, is the mutual induction between the loops of an inductor coil.

The commonly used symbol for an Inductor is,



6.3 INDUCTORS IN SERIES

For inductors in series, the total inductance is simply the sum of individual inductances, just as with resistors in series.

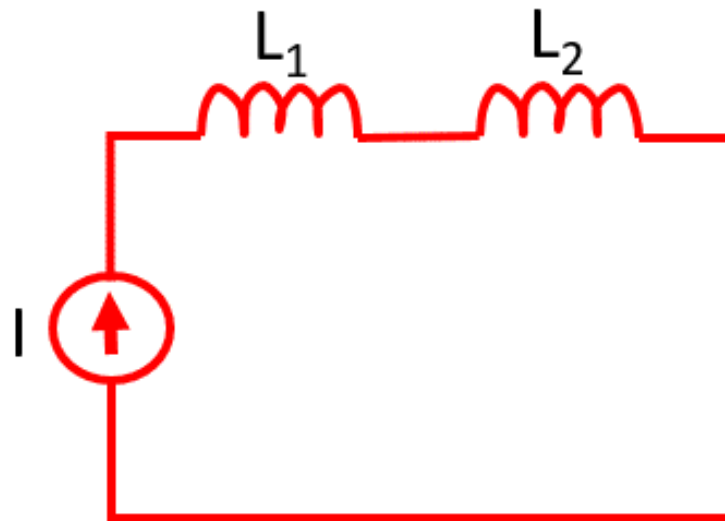

$$L_{eq} = L_1 + L_2 + \dots + L_n$$

Do note that this result is under the assumption that the magnetic fields of the inductors do not interact with each other.

6.4 INDUCTORS IN PARALLEL

For a parallel combination of inductors, the reciprocal of the equivalent inductance is the sum of the reciprocals of the individual inductances, just as with resistors.

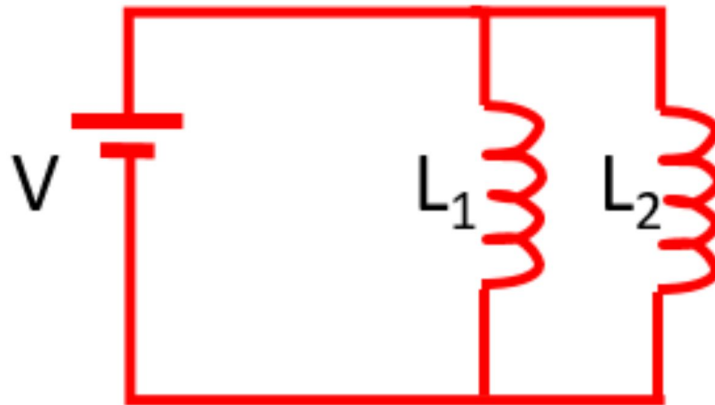

$$\frac{1}{L_{eq}} = \frac{1}{L_1} + \frac{1}{L_2} + \dots + \frac{1}{L_n}$$

Once again, this result is under the assumption that the magnetic fields of the inductors do not interact with each other.

6.5 CHARGING & DISCHARGING OF AN INDUCTOR

Like the capacitor, it takes some definite time for the inductor to become fully charged. When an uncharged inductor is connected to a DC source, it acts as an open circuit and the voltage across it is equal to the applied voltage, then the voltage exponentially decreases to zero after a while. On the contrary, the current flowing through the capacitor initially is zero. Later as the

time passes, the current builds to a maximum value and acts like a short circuit. How fast the capacitor charges up depends on any resistance present in the circuit.

Charging of a Inductor

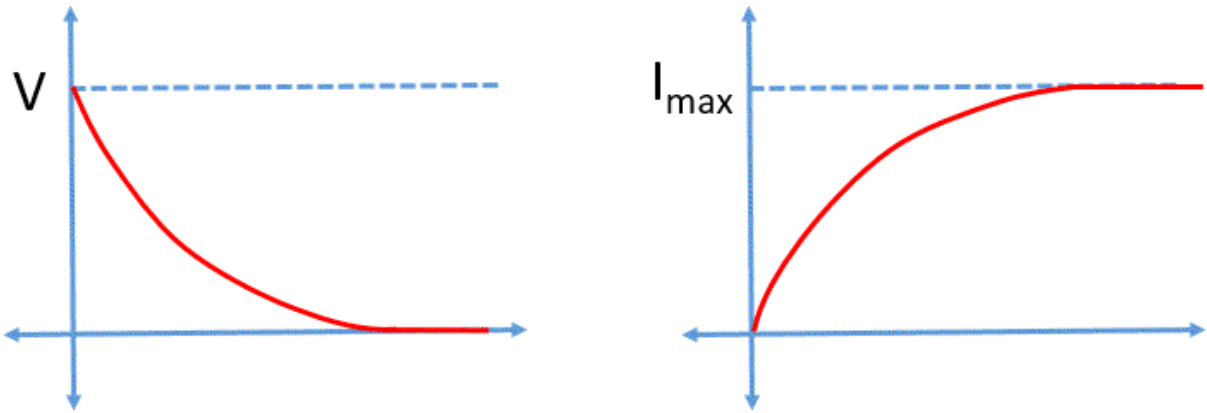

A fully charged inductor will discharge in exactly the reverse manner, the voltage picks up and the current drops exponentially.

Discharging of a Inductor

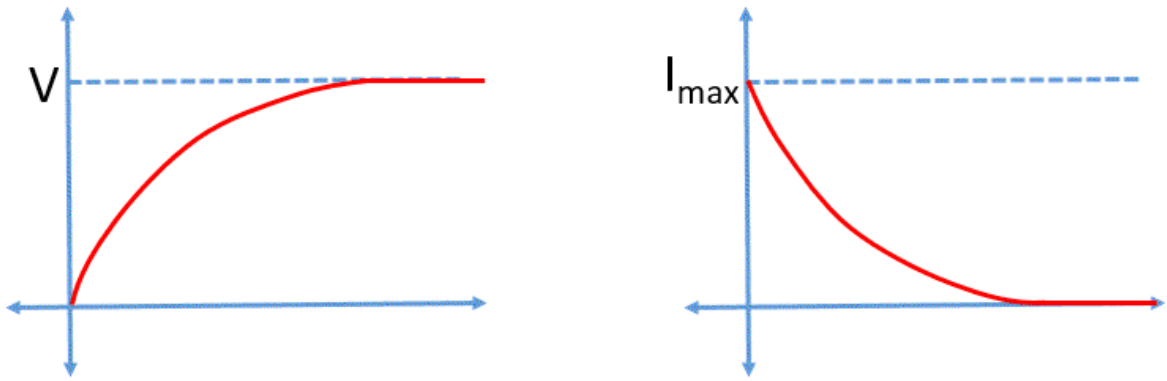

6.6 ENERGY STORED BY AN INDUCTOR

The EMF induced across the inductor due to variation in current (which leads to change in flux) is given by,

$$v = L \frac{di}{dt}$$

Therefore the instantaneous power which must be supplied to initiate the current in the inductor is,

$$P = vi = Li \frac{di}{dt}$$

$$\Rightarrow dW = Pdt = Li di$$

To find the total work done, we need to integrate this quantity from 0 to the maximum charge I.

$$W = \int_0^I Li di$$

$$W = \frac{1}{2} LI^2$$

7. AC FUNDAMENTALS

7.1 INTRODUCTION TO AC

So far we have only discussed about DC circuits and its analysis. Now we'll turn our attention to AC circuits. AC stands for Alternating current. AC is of interest to us, because 90% of supply used for commercial purposes is AC.

DC supply, we dealt with so far had constant magnitude and direction (positive to negative). A DC source like your car battery will always have a constant magnitude between its terminals. Its positive and negative terminals will always remain as it is. On the contrary, for AC supply like your power outlet, both magnitude and direction changes periodically. The whole process takes place in 2 parts or 2 half cycles, Positive half cycle and the negative half cycle. In the positive half cycle, the voltage (and therefore the current) will gradually increase from 0 to a max value, then starts decreasing back to zero. The same thing happens in the negative half cycle, but in reverse direction. Reverse direction?? So does the current flows from negative to positive terminal in the negative half cycle?? No, it doesn't happen that way. It's the terminals that change its polarity. The terminal that would have been positive in the positive half cycle changes to negative in the negative half cycle and similarly for the other terminal. This essentially means that there is no fixed Positive and Negative terminals for AC supply. A terminal can have one polarity in a half cycle and the opposite polarity in the other half cycle.

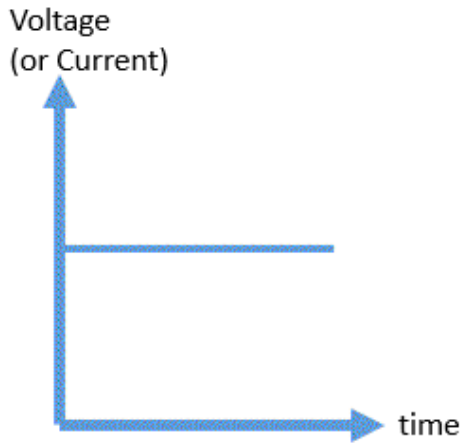

DC

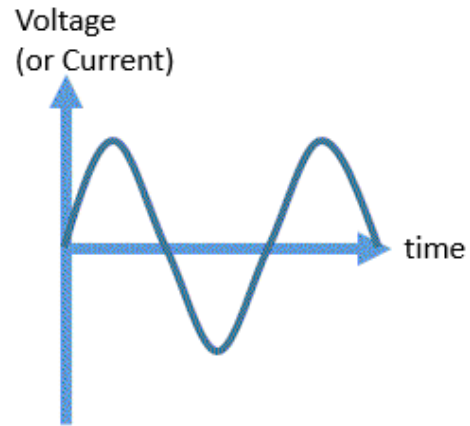

AC

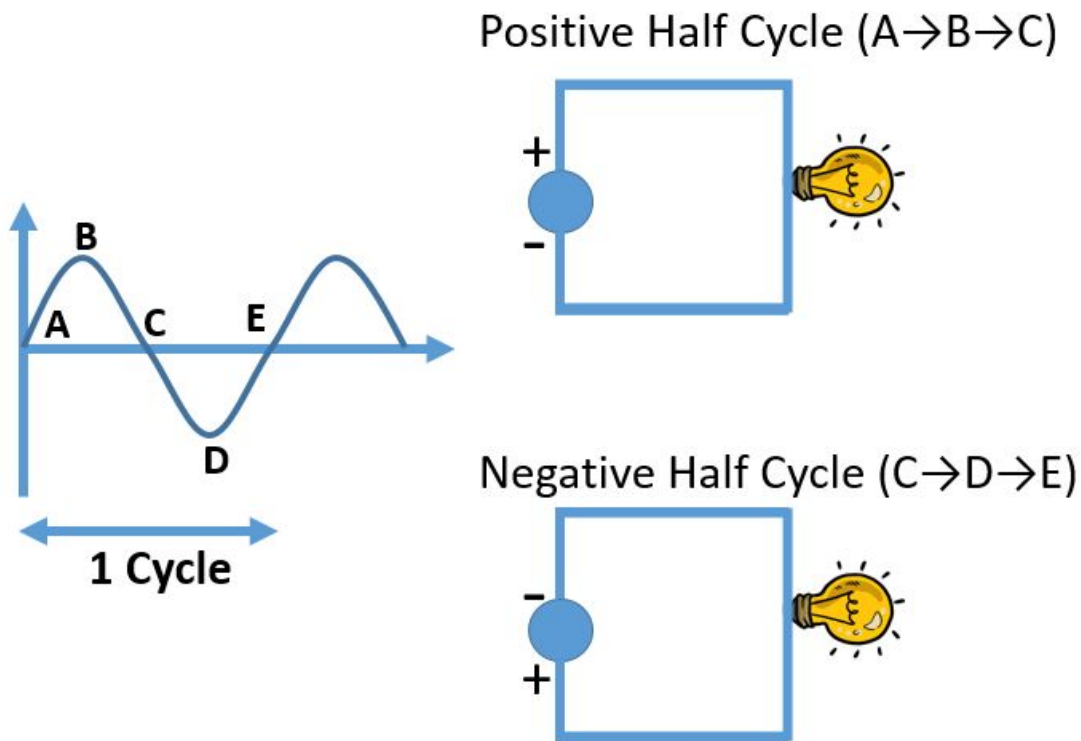

AC is complex, DC was straightforward. Why would we even bother generating AC? That would be the obvious question on your mind at this point. The answer is simple, it's a way lot easier to generate, transmit and manipulate AC supply. Unfortunately for us, this simplicity in operation doesn't translate into easier math.

So far we have discussed about variation of voltage in AC supply, but not about the pattern of this variation. Does the voltage shoot up to a max value all of a sudden and fall back to zero again or does it follow a triangular pattern??

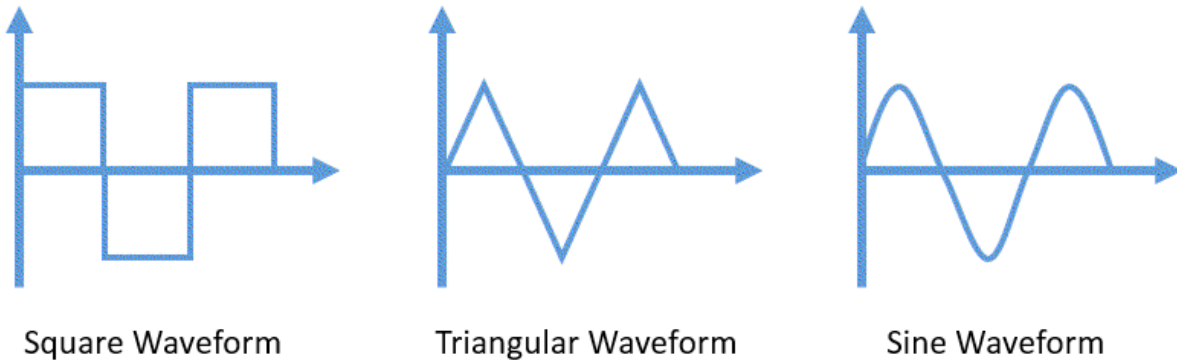

All these patterns are called **waveforms**. A waveform is basically a plot of a quantity (in our case voltage/current) against time. All these waveforms shown in the figure above and many more, are definite possibilities and many of them have real practical applications. But the pattern or waveform of our interest at least in this book, is the sine waveform. For commercial AC supply pure sine wave is the most preferred waveform, because it's easier to generate and mathematically simpler to analyze.

7.2 TERMINOLOGY RELATED TO A WAVEFORM

7.2.1 Instantaneous value

The value or the magnitude of an alternating quantity at a particular instant of time is known as its instantaneous value. For example, in the Voltage-time waveform, the instantaneous values of voltage at instants t_1 , t_2 , t_3 are v_1 , v_2 and v_3 respectively. Instantaneous quantities are always denoted by small letters (v , e , i etc.)

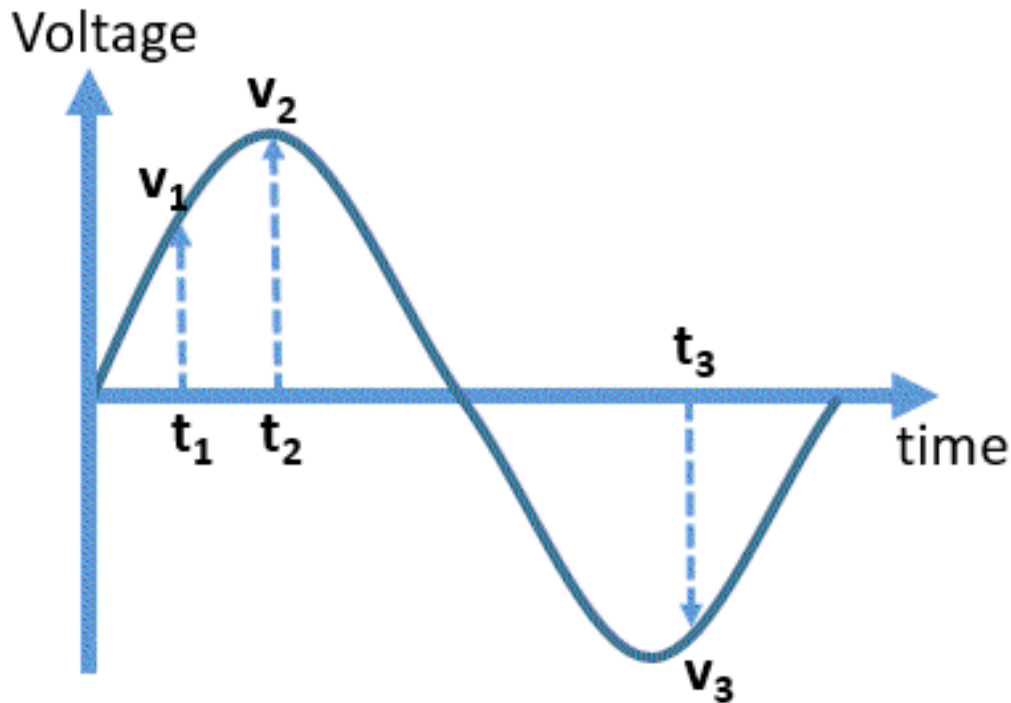

7.2.2 Cycle

A Cycle is a portion of a waveform, which when repeated makes up the entire waveform. In the figure below, the shaded portion is the only unique part of the entire waveform, rest of the waveform is just repetitions of this portion. A more formal definition would be: an alternating quantity is said to have completed a cycle when it goes through the entire range of positive and negative instantaneous values without reoccurrence. Obviously it goes without mentioning that the concept of a cycle is only relevant to periodic waveforms like the sine waveform. Do note that a cycle needn't start from zero value and end at zero value. It's only for convenience. For example, V_{\max} to the next V_{\max} is also a cycle.

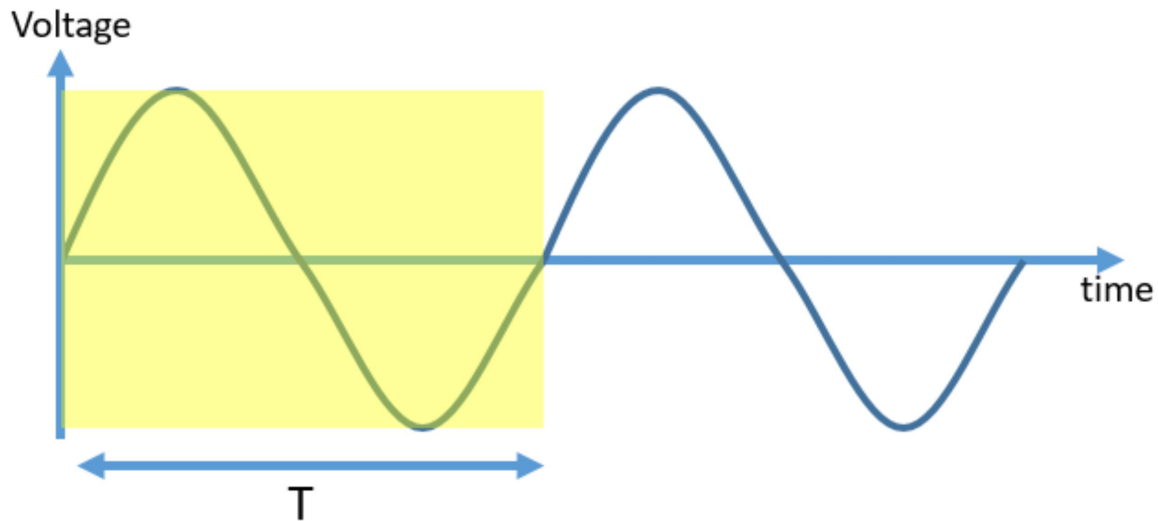

7.2.3 Time Period

The time period is the time taken by an alternating quantity to complete one cycle. In other words, a cycle of an alternating quantity repeats after every T seconds, where T denotes the Time period.

7.2.4 Frequency

The number of cycles completed by an alternating quantity in a second is known as its frequency. It's measured in cycles per second or Hertz. So a 60 Hz supply means that the waveform complete 60 cycles in a second. It is denoted by f . Did you notice something interesting?? The definitions for Frequency and Time Period were kind of the reverse of each other. One is the time taken for a cycle and other is the number of cycles per time. That's because Frequency and Time Period are inversely related quantities i.e.

$$T = \frac{1}{f}$$

So as the frequency increases, time period decreases and vice versa.

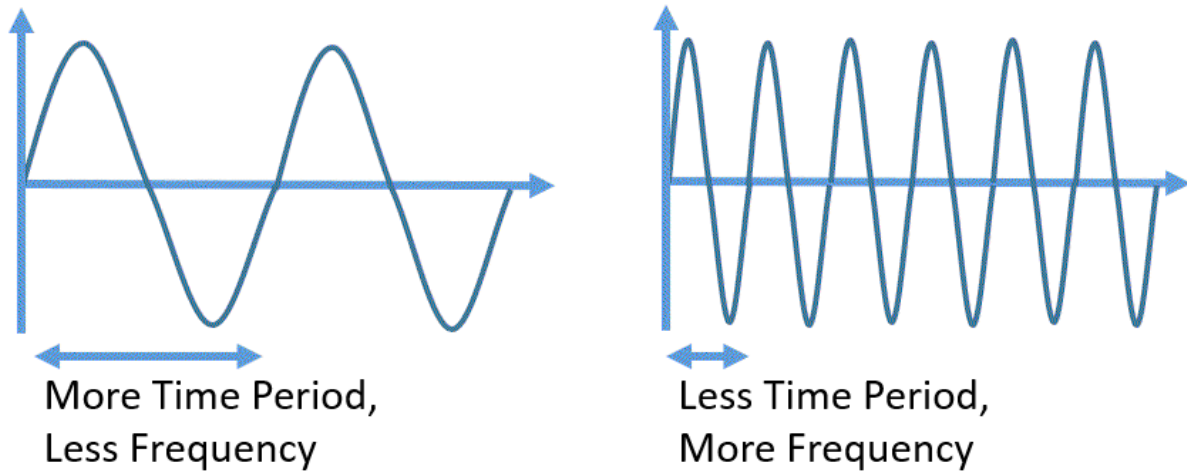

7.2.5 Amplitude

Amplitude is the maximum value (positive or negative) attained by an alternating quantity during its cycle.

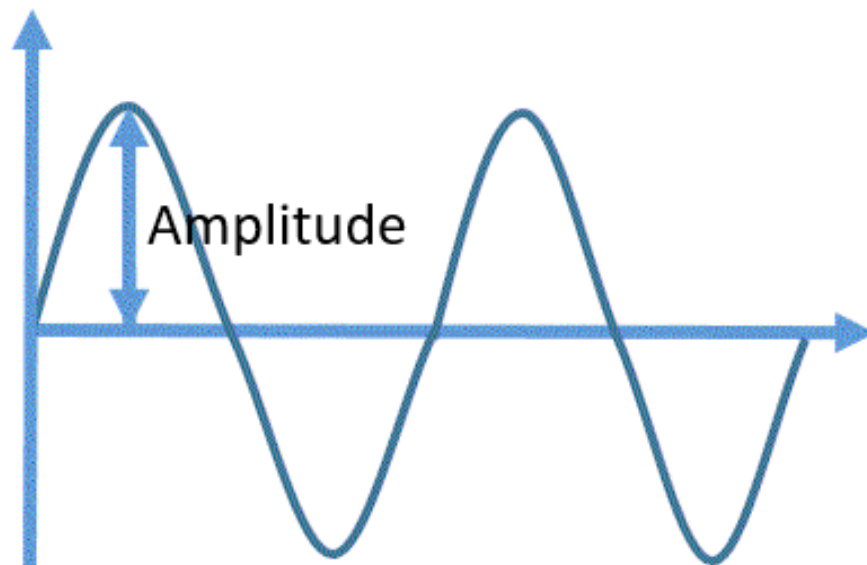

7.3 EQUATION

Now that you have a basic idea about alternating quantities, let's talk math. The general equation for an AC sinusoidal voltage is:

$$v = V_{\max} \sin(\omega t)$$

This equation can be understood better, if we take a look at the working of a generator.

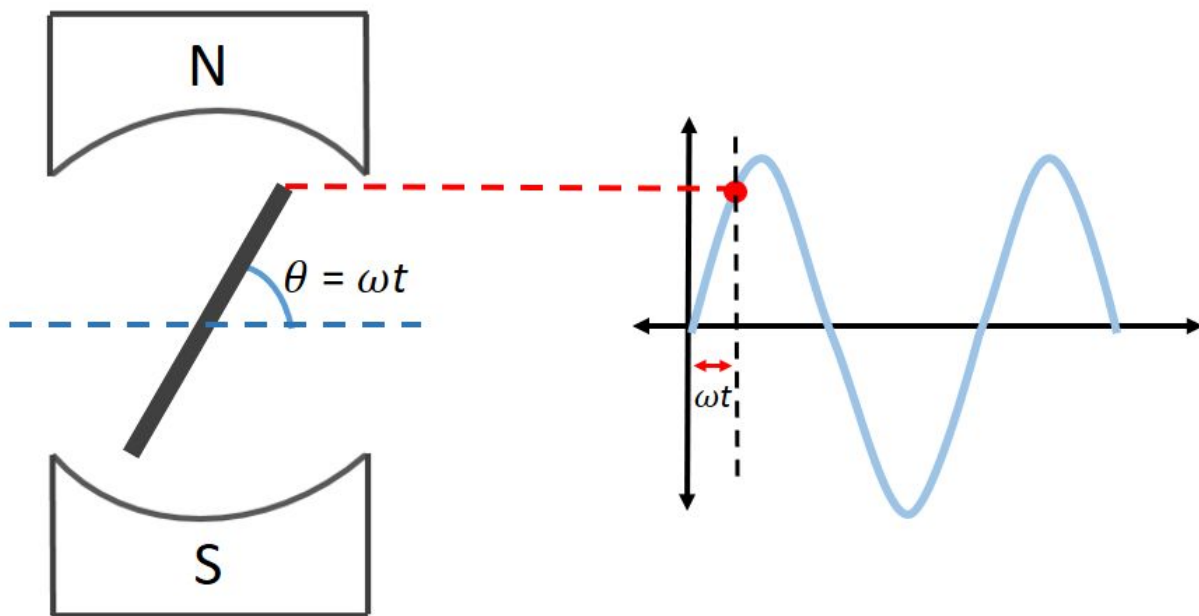

Inside a generator a coil is made to rotate with the help of external forces like water or steam or other form of energy. As the coil moves within a magnetic field, voltage is induced in the coil, this is the basic working. The voltage induced is a function of the sine of the angle (Θ) the coil makes with the center line. When the coil is along the center line, no voltage is induced and when the coil is at 90 degrees to the center line, max voltage is induced. It is better to represent the voltage as a function of time instead of the physical angle of the coil, so the term ωt is used. It is usually measured in radians.

Going back to the general equation, v represents the instantaneous value of the voltage and V_{\max} represents the amplitude of the voltage waveform.

7.4 AVERAGE VALUE

Average value is a pretty common and useful concept in technical fields, yet its meaning is often misunderstood. Imagine sand piled up in the form of a mountain over a certain distance, then the average value is that height obtained if the same distance is maintained while the sand is leveled off.

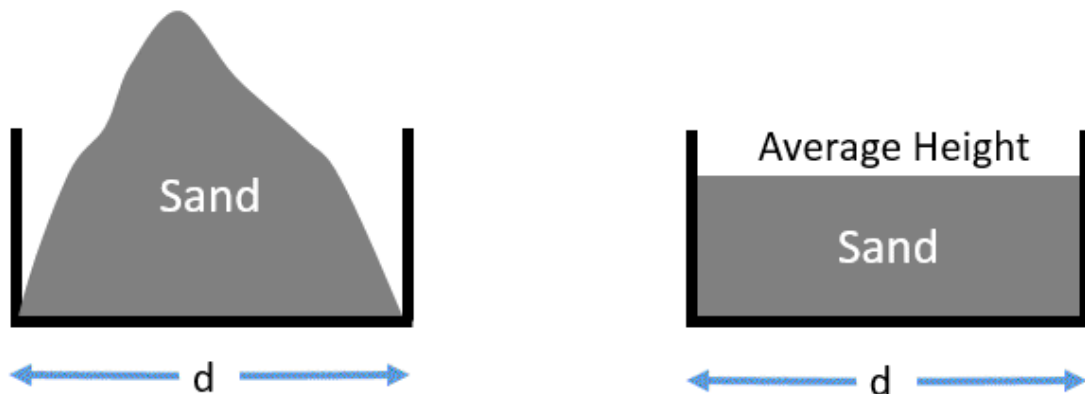

From observation itself, it is pretty clear that the average value of the sine waveform over a full cycle is zero. So for symmetrical waveforms such as the sine waveform, the average value is calculated over a half cycle rather than the full cycle.

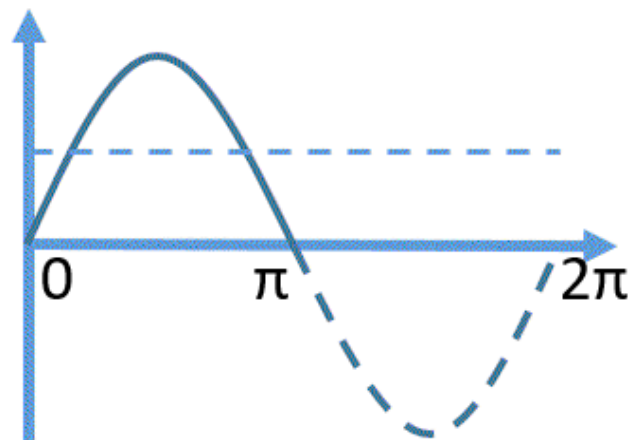

$$\begin{aligned} \text{Average value} &= \frac{\text{Area under the curve}}{\text{Length of the base}} = \frac{\int_0^{\pi} V_m \sin(\omega t)}{\pi - 0} \\ &= \frac{V_m [-\cos(\omega t)]_0^{\pi}}{\pi} = \frac{V_m [-\cos(\pi) + \cos(0)]}{\pi} \end{aligned}$$

$$V_{\text{avg}} = \frac{2V_m}{\pi}$$

7.5 RMS VALUE

For a long time, AC was thought to be a useless form of electricity, primarily because its average value is zero over the full cycle, but experiments showed otherwise. When an AC current is passed through a wire, the wire gradually heated up, showing that power is being delivered. How is that possible?? It's possible because both Voltage and Current are changing direction simultaneously and power being the product of these 2 quantities, power is always delivered. Consider this ridiculous example, say someone punched in your face, then he decides to you punch on the back of your head, but if you turn around at the exact moment, you'll once again be punched in the face. So as long as both you and the attacker moves simultaneously, all the punches are delivered at the same place, your face (Ouchh!). Similarly as long as both current and voltage have same direction, their product is always positive, hence the power is always delivered.

The electrons are forced to switch direction ever so quickly that they practically remain still and yet power is being delivered by them. Getting an intuitive feel of how AC power is delivered is not the easiest of tasks, but a water analogy might help. When you throw a rock into a pond, the ripples formed will travel throughout the pond causing leaves and other debris to

oscillate on the water's surface. This means that energy has been transferred from the rock to the floating leaves, even though no single water molecule has actually travelled all the way from the rock's impact point to the floating debris. The energy is carried by the waves formed on the water's surface, in which chains of water molecules push and pull on each other in succession, transferring energy without actually moving anyone around.

By now it should be pretty clear that average value is not the most effective parameter to measure AC. So we need a better parameter to quantify AC, it is called the RMS or Root Mean Square value. It is developed by comparing the heating effect caused by DC and AC sources. **The RMS value of AC current is the magnitude of DC current which need to be passed through a resistor, so as to produce same heat as the AC, for the same duration of time.** Say we pass an AC current through a resistor for 1 minute and measure its temperature and it's found to be say 100°C. Now if we connect a DC source to the same resistor for the same duration of 1 minute and the temperature is raised to 100°C. Then, that value of DC current gives the RMS value of the AC current.

$$P_{DC} = P_{AC(avg)}$$

$$\Rightarrow I_{RMS}^2 R = \frac{I_m^2 R}{2}$$

$$\therefore I_{RMS} = \frac{I_m}{\sqrt{2}}$$

Similarly,

$$V_{RMS} = \frac{V_m}{\sqrt{2}}$$

Hence the RMS value of AC is $1/\sqrt{2}$ or 0.707 times the maximum value. When you measure the voltage of your power socket, the reading indicates the RMS value. Unless specifically mentioned, all values related to AC voltages and currents are RMS values.

7.6 PHASE

In our general equation, we have only considered sinusoids having zero value at $t=0, \pi$ and maximum value at $t=\pi/2, 3\pi/2$. But this needn't be the case always, sinusoids can be shifted to the left or the right as shown below.

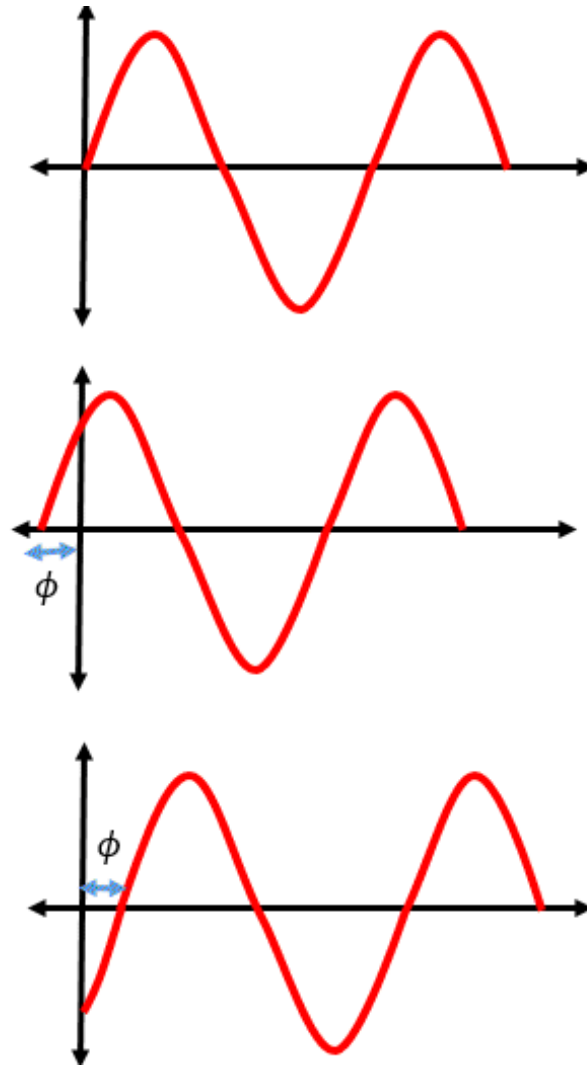

The waveforms are identical in all aspects, but the second waveform starts earlier than the first, and the third waveform has a delayed start than the first. In other words, the second wave leads the first wave and the third wave lags the first. The lead or lag of a waveform is denoted by ϕ known as the phase angle.

Considering this concept of phase angle, we can modify the general equation for an AC sinusoidal voltage as,

$$v = V_{\max} \sin(\omega t + \phi)$$

The difference between phase angles of 2 sinusoids is called the phase difference.

7.7 COMPLEX NUMBERS

DC circuit analysis we did so far were pretty easy, because voltages and currents could be added or subtracted directly, but now that we introduced the demon called phase, things are about to get a little trickier. To tackle this problem, we need the help of a mathematical tool called [complex numbers](#).

Complex numbers can be represented in 2 forms:

1. Rectangular Form: It's the most commonly used representation for complex numbers. Note that in electrical engineering, letter **j** is used to denote the imaginary part, instead of **i**, to not get mixed up with symbol for current.

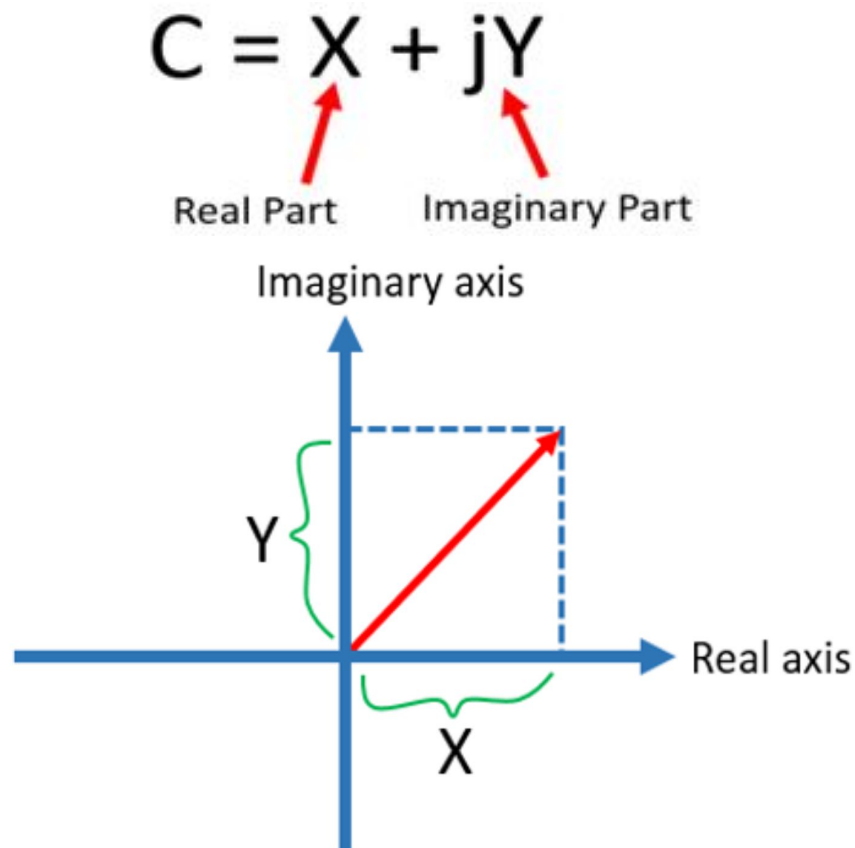

2. Polar Form: In polar form, a quantity is denoted in terms of its magnitude and the angle it makes with the positive x-axis.

$$C = Z \angle \theta$$

Magnitude Angle

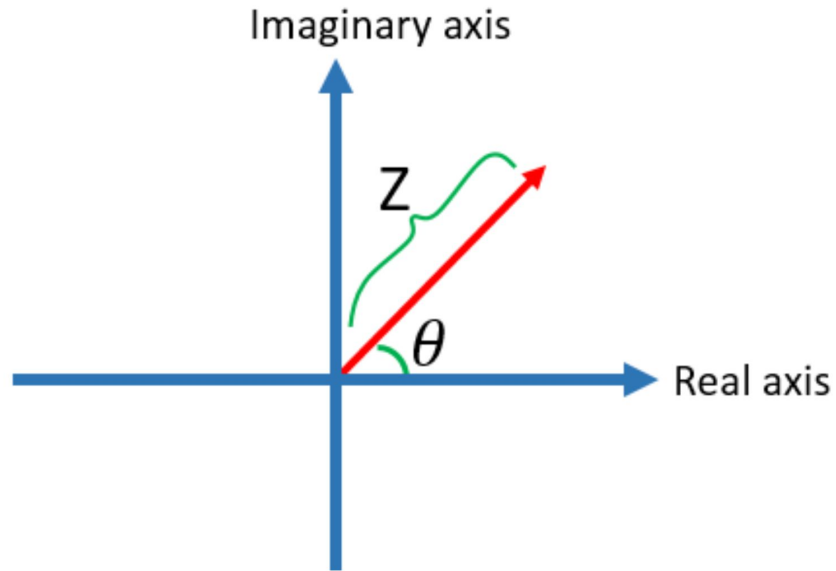

Converting between the two forms is very easy and will come in handy later.

Rectangular to Polar Form

$$Z = \sqrt{X^2 + Y^2}$$

$$\theta = \tan^{-1} \frac{Y}{X}$$

Polar to Rectangular Form

$$X = Z \cos \theta$$

$$Y = Z \sin \theta$$

7.8 OPERATIONS USING COMPLEX NUMBERS

7.8.1 Addition/Subtraction:

Complex Addition/ Subtraction is as easy as they seem. To add two complex numbers, simply add the real and imaginary parts separately. Similarly, to subtract two complex numbers, simply subtract the real and imaginary parts separately.

If,

$$C_1 = X_1 + jY_1 \text{ and } C_2 = X_2 + jY_2$$

Then,

$$C_1 \pm C_2 = (X_1 \pm X_2) + j(Y_1 \pm Y_2)$$

7.8.2 Multiplication:

To multiply two Complex numbers in rectangular form, each term of the first complex number is multiplied separately by each term of the second complex number. Then the real parts and the imaginary parts are separated out to obtain the product complex number.

$$\begin{aligned} C_1.C_2 &= (X_1 + jY_1).(X_2 + jY_2) \\ &= X_1X_2 + jX_1Y_2 + jY_1X_2 + jY_1jY_2 \\ &= (X_1X_2 - Y_1Y_2) + j(X_1Y_2 + X_2Y_1) \end{aligned}$$

Complex multiplication is a lot easier in polar form, the magnitudes are multiplied and the angles added algebraically.

$$\begin{aligned} C_1.C_2 &= Z_1 \angle \theta_1 . Z_2 \angle \theta_1 \\ &= Z_1Z_2 \angle (\theta_1 + \theta_2) \end{aligned}$$

7.8.2 Division:

In rectangular form, Complex multiplication is done by multiplying both the numerator and denominator with the denominator of the denominator and separating out the real and imaginary parts.

$$\frac{C_1}{C_2} = \frac{(X_1 + jY_1)(X_2 - jY_2)}{(X_2 + jY_2)(X_2 - jY_2)}$$

In polar form, the magnitudes of the numerator is divided by the magnitude of the denominator and the angle is subtracted from the other.

$$\begin{aligned}\frac{C_1}{C_2} &= \frac{Z_1 \angle \theta_1}{Z_2 \angle \theta_2} \\ &= \frac{Z_1}{Z_2} \angle (\theta_1 - \theta_2)\end{aligned}$$

In the next chapter, we'll put all that we learnt in this chapter in understanding AC circuit further.

8. AC CIRCUITS

8.1 AC THROUGH RESISTANCE

Before we delve into the deep end, we will study the behavior of AC when passed through our amazing trio of resistors, capacitors, and inductors and build from there. Resistance is the easiest component to analyze in AC circuits, because it behaves the same way for DC as well as AC.

Consider the circuit shown below, where an AC voltage $v = V_m \sin(\omega t)$ is applied across a resistor R .

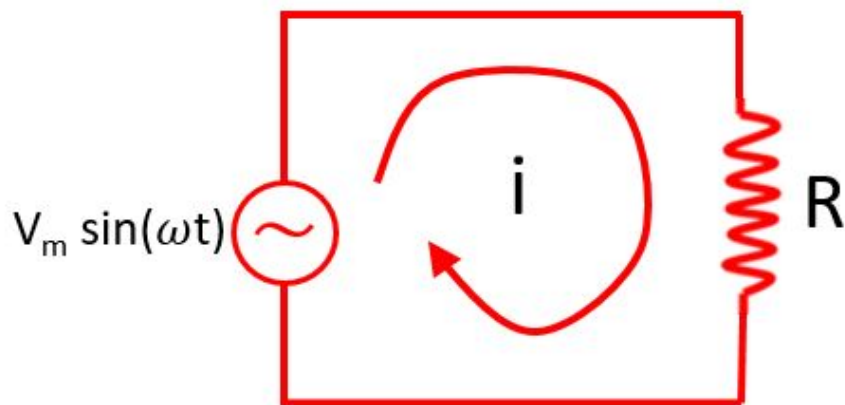

Obviously a current will flow through the circuit, which as per the ohms law is given by,

$$\begin{aligned} i &= \frac{v}{R} = \frac{V_m \sin(\omega t)}{R} \\ &= \left(\frac{V_m}{R} \right) \sin(\omega t) \end{aligned}$$

If you compare this equation with the equation for the applied voltage, you can identify that the current and applied voltage are in phase (phase shift $\phi = 0$) and also the maximum values are related as, $I_m = V_m/R$. Both the current and the voltage waveforms are exactly the same and only difference is that the voltage waveform is R times bigger than the current waveform, as shown below.

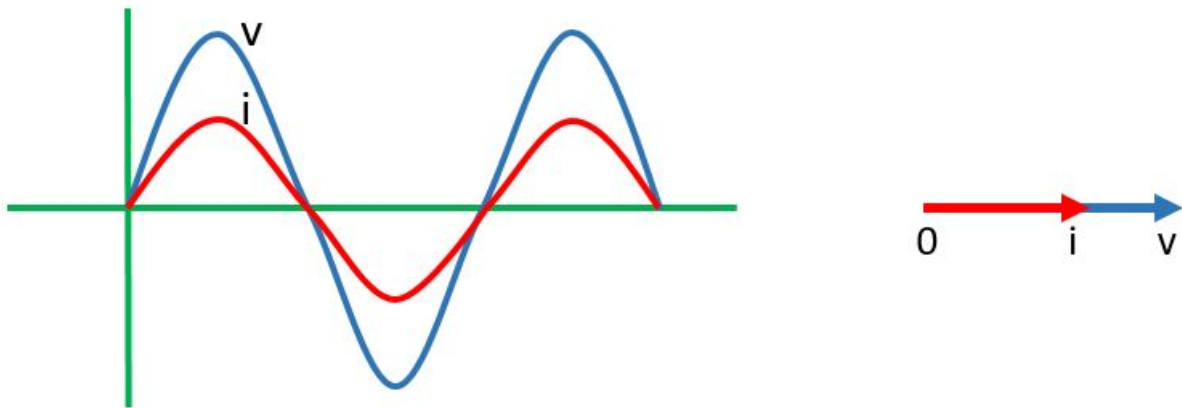

8.2 AC THROUGH INDUCTOR

We have learnt that, an inductor is a component that resists change in current, due to its self-inductance property. When an Inductor is connected to an AC source, the current will repeatedly change in the magnitude and direction. The inductor will try to oppose this change by inducing a voltage across it, which limits the current in the circuit. This opposition due to the inductance is called inductive reactance. Inductive reactance is denoted by the symbol X_L and is measured in ohms.

Inductive reactance is dependent on the frequency of the applied AC voltage, as given by the relation,

$$X_L = \omega L = 2\pi f L$$

As the frequency of the applied voltage increases, the Inductive reactance increases and hence the voltage drop across it also increases. The inductor can be thought of as a variable resistor, whose opposition to the current is controlled by the frequency of the supply voltage.

Consider an AC voltage applied to a pure inductor (the coil offers no resistance) of inductance L , as shown in the circuit below.

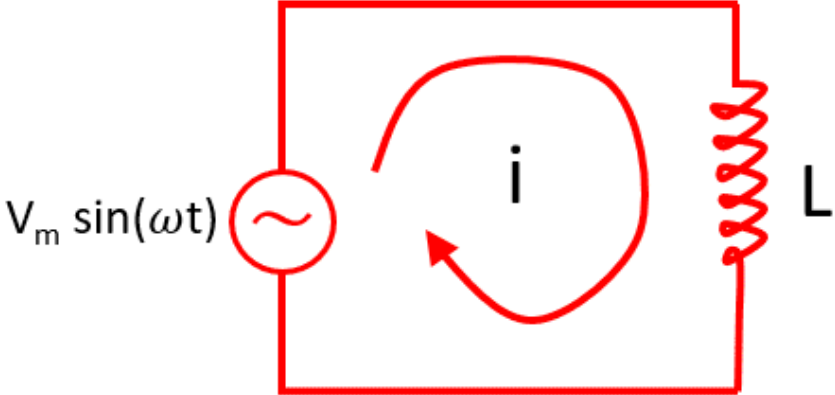

The current flowing through the circuit can be calculated as follows:

$$v_L = -L \frac{di}{dt}$$

Since the applied emf and the induced emf oppose each other,

$$V = -V_L$$

$$\Rightarrow V_m \sin \omega t = L \frac{di}{dt}$$

$$i = \int \frac{V_m \sin \omega t}{L} dt = \frac{-V_m}{\omega L} \cos \omega t$$

$$i = \frac{V_m}{X_L} \sin\left(\omega t - \frac{\pi}{2}\right)$$

This derivation itself isn't very important, but what is important are these conclusions that can be made from it.

1. Comparing the equation with that of supply voltage, it is obvious that the current has a phase angle of $-\pi/2$ or -90° i.e. **the current lags the applied voltage by $\pi/2$ or 90° .**
2. The maximum magnitude of current is related to the maximum magnitude of the applied voltage as,

$$I_m = \frac{V_m}{X_L}$$

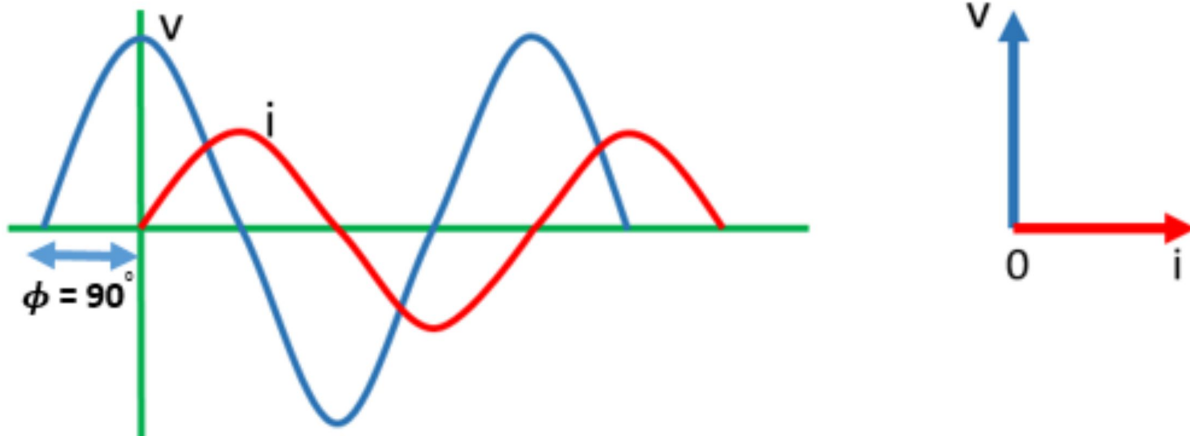

8.3 AC THROUGH CAPACITOR

When an AC voltage is applied to a capacitor, a voltage is developed across its plates, as the electrostatic charge is built up. This impressed voltage opposes the applied voltage and limits the flow of current in the circuit. This opposition caused by capacitance is called capacitive reactance (X_C) and is measured in ohms. It is similar to Inductive reactance in a lot of ways, but the key difference is that the capacitive reactance opposes the change in voltage, whereas the inductive reactance opposes the change in current caused as a result of the applied voltage.

Capacitive reactance is also frequency dependent, as given by the relation,

$$X_C = \frac{1}{\omega C} = \frac{1}{2\pi f C}$$

Obviously as you can see, unlike inductive reactance, the capacitive reactance is inversely proportional to the frequency of the supply voltage. Why it is so, is beyond the scope of this book. Think of it this way, as voltage changes faster, lesser the time for charge to accumulate, hence lesser capacitive reactance.

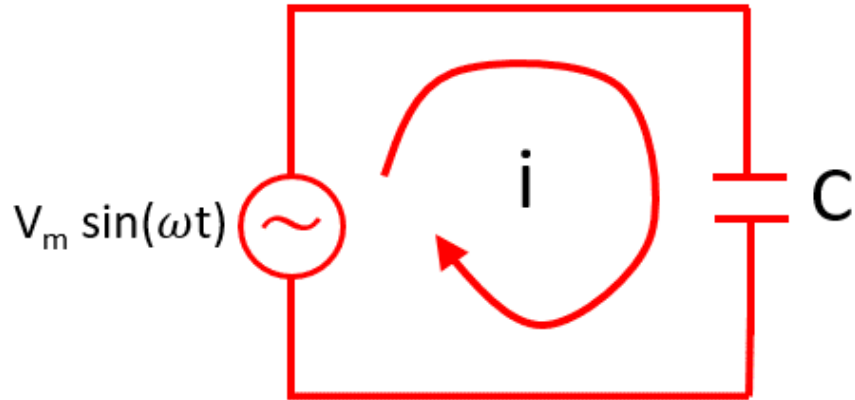

The current flowing in the circuit, shown above can be determined as follows:

$$i = \frac{dq}{dt} = C \frac{dv}{dt}$$

$$i = C \frac{d(V_m \sin \omega t)}{dt}$$

$$= V_m C \frac{d(\sin \omega t)}{dt} = V_m \omega C \cos \omega t$$

$$i = \frac{V_m}{X_C} \sin\left(\omega t + \frac{\pi}{2}\right)$$

Again this derivation itself isn't very important, but some inferences can be made from it.

1. Comparing the equation with that of supply voltage, it is obvious that the current has a phase angle of $\pi/2$ or 90° i.e. **the current leads the applied voltage by $\pi/2$ or 90° .**
2. The maximum magnitude of current is related to the maximum magnitude of the applied voltage as,

$$I_m = \frac{V_m}{X_C}$$

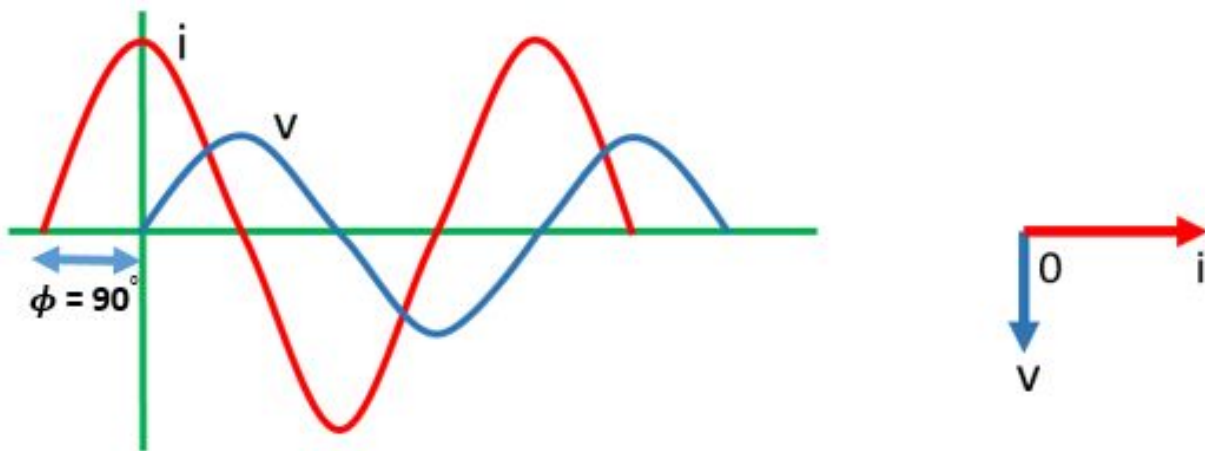

8.4 IMPEDANCE

Impedance is defined as the opposition to the flow of alternating current in a circuit. As we have seen, in a pure inductive circuit, the opposition was the inductive reactance, in a pure capacitive circuit, it was the capacitive reactance and in a resistive circuit it was the resistance. Similarly, in a circuit with one or more of these elements, in any combination, the impedance is the total current limiting element in the circuit. It is denoted by Z and its unit is obviously Ohm.

As seen in the previous sections, the Inductive reactance introduces a phase shift of -90° to the current and capacitive reactance introduces a phase shift of $+90^\circ$ to the current. Whereas the resistance doesn't cause any phase shift. Hence the inductive part of the circuit leads the resistive part of the circuit by 90° and similarly, the capacitive part of the circuit lags the resistive part of the circuit by 90° . For this reason, Impedance is a complex quantity that has a magnitude and a phase.

Here's an example of a phasor diagram for a circuit containing all these elements.

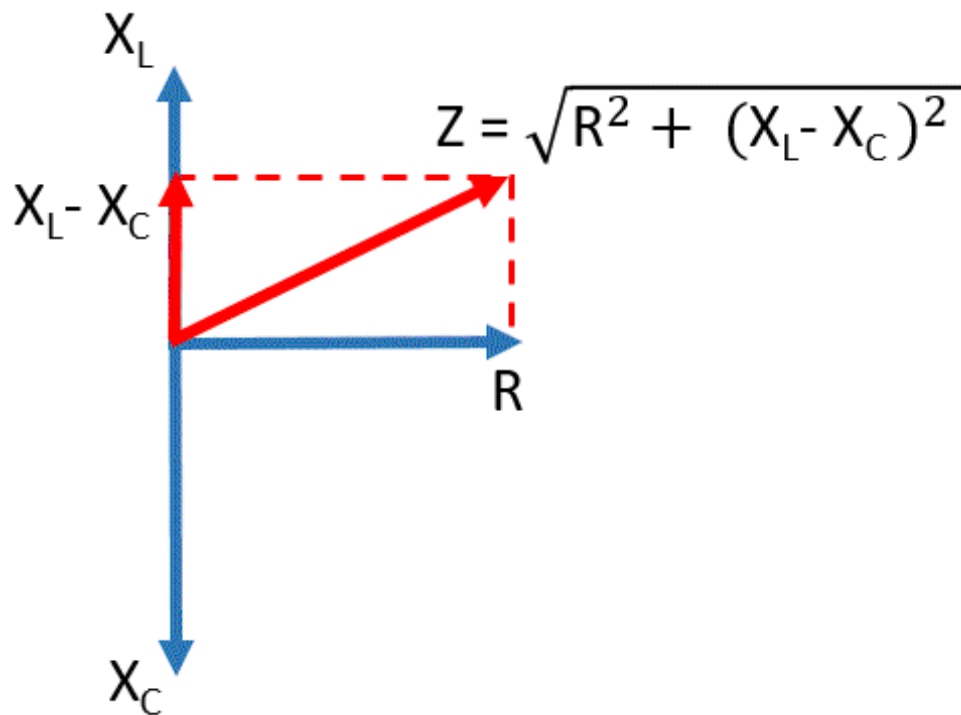

X_L and X_C lie on the Imaginary axis of the complex plane. Therefore to represent them, X_L is multiplied by j and X_C is multiplied $-j$. Here are some examples on how to calculate Impedance of a circuit.

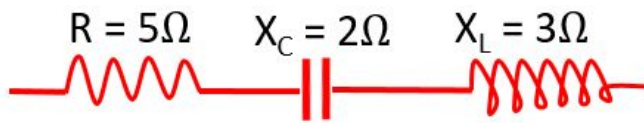

$$Z = 5 - 2j + 3j = 5 + j$$

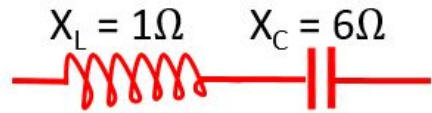

$$Z = -5j$$

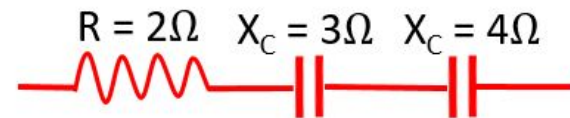

$$Z = 2 - 7j$$

By the way, impedances in series/parallel are calculated in the same way as resistances in series/parallel.

Impedance in series: $Z = Z_1 + Z_2 + Z_3 + \dots$

Impedance in parallel: $\frac{1}{Z} = \frac{1}{Z_1} + \frac{1}{Z_2} + \frac{1}{Z_3} + \dots$

Here are some more examples:

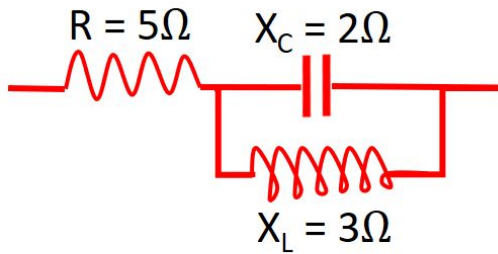

$$Z = 5 + \left(\frac{-2j \times 3j}{-2j + 3j} \right) = 5 - 6j$$

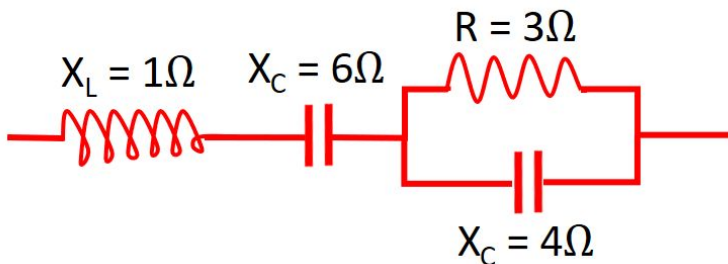

$$Z = j - 6j + \left(\frac{3 \times -4j}{3 - 4j} \right) \\ = 1.92 - 6.44j$$

8.5 POWER & POWER FACTOR

As mentioned earlier in the book, electrical power is the product of voltage and current. But how does this translate to AC circuits, where both voltage and current both vary sinusoidally? Does the power also vary?

Generally if,

$$v = V_m \sin(\omega t + \theta_v) \quad \&$$

$$i = I_m \sin(\omega t + \theta_i)$$

Then,

$$P_{\text{avg}} = \frac{V_m I_m}{2} \cos(\phi)$$

Where, $\phi = \theta_v - \theta_i$

The term $\cos(\phi)$ is called the Power factor of the circuit.

Resistive circuit:

In the earlier section we saw that in a purely resistive circuit, the voltage and the current are in phase. In the first half cycle, both voltage and current are positive, therefore power is the product of these two quantities is also positive in the first half cycle. Similarly, in the second half cycle, both the voltage and current are negative, therefore the power is positive in this half cycle too. Hence the average power is always positive in a pure resistive circuit. In a purely resistive circuit, phase difference is zero, hence the power factor is equal to 1.

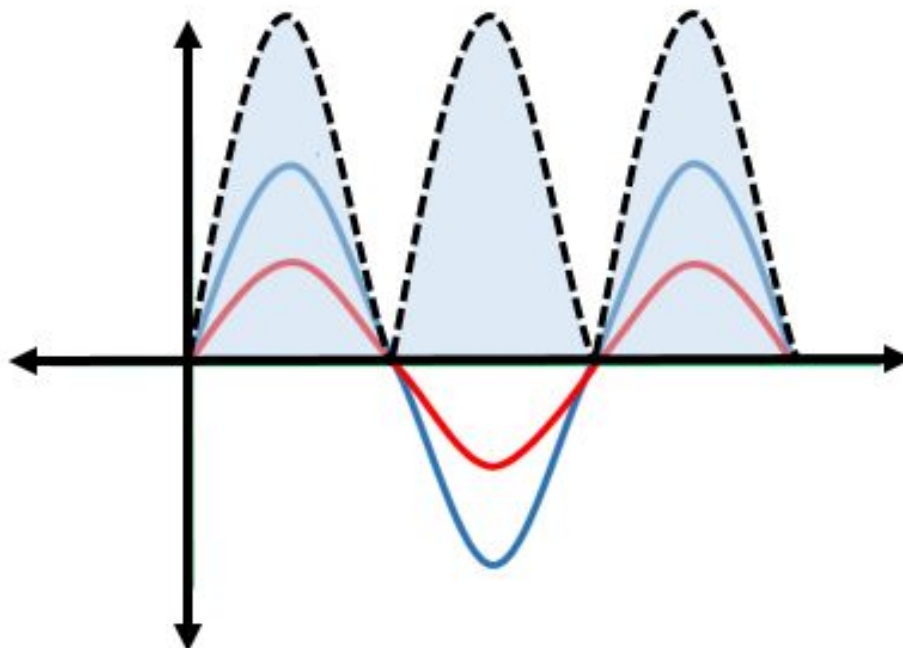

Inductive circuit:

In a purely inductive circuit, the current lags the voltage by 90° . Therefore the power factor is zero and consequently the average power is also zero.

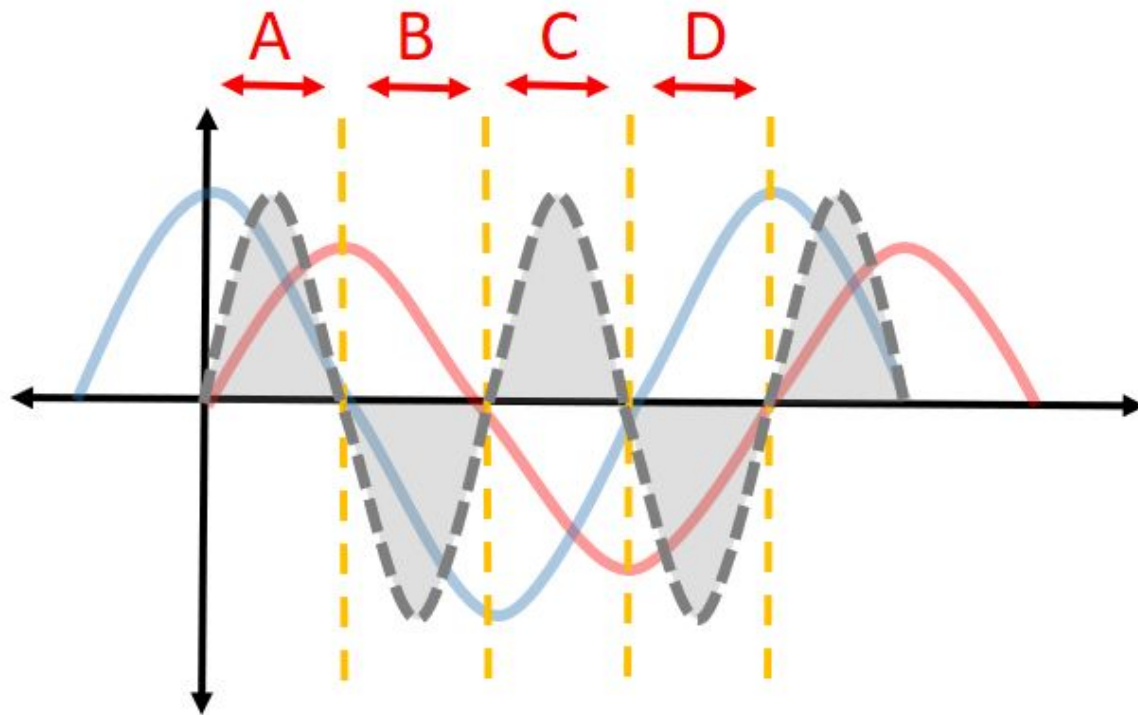

In the interval A, both the voltage and current are positive, therefore the power is also positive. During this interval, the power is absorbed by the inductor to set up a magnetic field. In the interval B, the current is positive, but the voltage is negative, therefore the power is negative. Negative power means the power is being returned back to the source, as the magnetic field collapses. This process continues for the next 2 intervals C and D as well. So it is very evident that over a full cycle, the average power absorbed by the inductor is zero.

To sum up, a pure inductor doesn't dissipate energy like a resistor, it only stores energy in the form of magnetic field for a while, then releases it back.

Capacitive circuit:

In a purely capacitive circuit, the current leads the voltage by 90° . Therefore, similar to a purely inductive circuit, here too the power factor and the average power are zero.

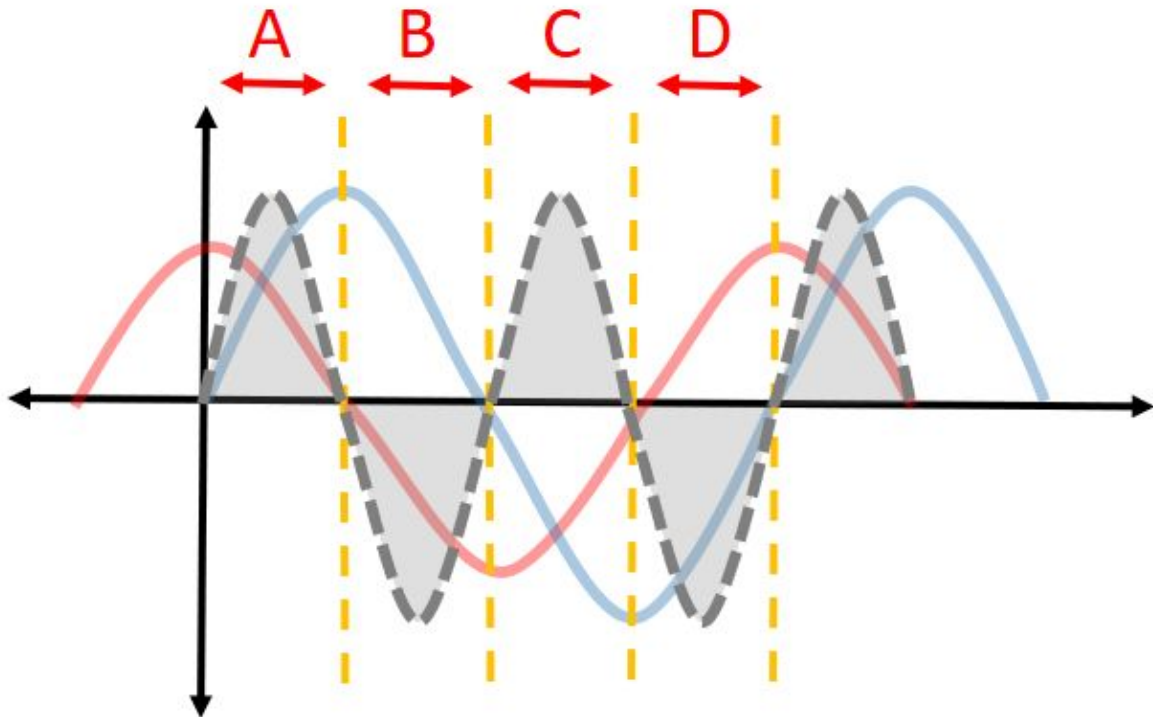

In the interval A, both the voltage and current are positive, therefore the power is also positive. During this interval, the power is absorbed by the capacitor to build up charge and increase electrostatic energy. In the interval B, the voltage is positive, but the current is negative, therefore the power is negative. Now the capacitor starts discharging and the returns gathered electrostatic energy back to the source. This process continues for the next 2 intervals C and D as well. So over the full cycle, the average power absorbed by the capacitor is zero.

By now, you may have figured out that, resistor is the only component that absorbs and dissipates energy, whereas inductors and capacitors can only store energy for a while.

Returning to our earlier discussion, the power factor of a circuit tells us the amount of resistance contributing to the total impedance of the circuit. Mathematically,

$$\cos\phi = \frac{R}{|Z|}$$

To sum up, the Electrical power in an AC circuit, depends on three factors: Voltage, Current and the Power factor.

8.6 SERIES R-L CIRCUIT

Before we close out this chapter, we'll take a look at few circuits with combinations of these components and their response to AC, to solidify what we've learnt so far.

First stop is the RL series circuit, shown below.

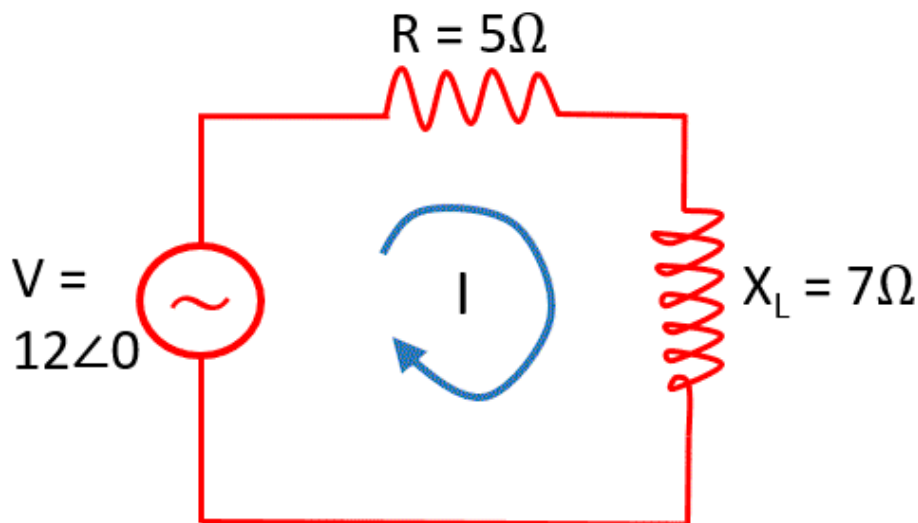

Since you are more or less familiar with complex number math at this stage, we'll go that route. The total impedance of this circuit is $Z = 5 + j7$ (Always remember to multiply X_L by j) and the current and the power factor can be calculated as,

$$I = \frac{V}{Z} = \frac{12}{5+j7}$$

$$= 0.81 -j1.13$$

$$\cos \phi = \frac{R}{|Z|} = 0.58$$

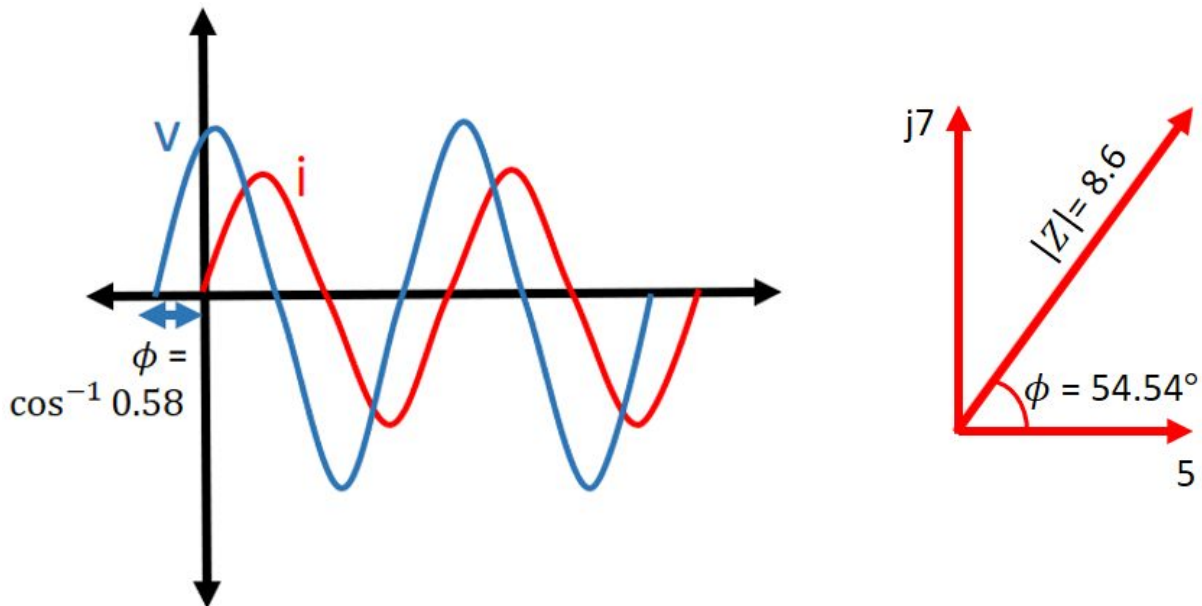

Generally, in an RL series circuit, the current lags the applied voltage by an angle less than 90° . If the resistance is very high compared to inductive reactance, then the phase difference will be closer to zero and if resistance is negligible, then the phase difference will be close to 90° . In our example, the current lags the voltage by 54.54° .

8.7 SERIES R-C CIRCUIT

Consider the example of an RC series circuit shown below.

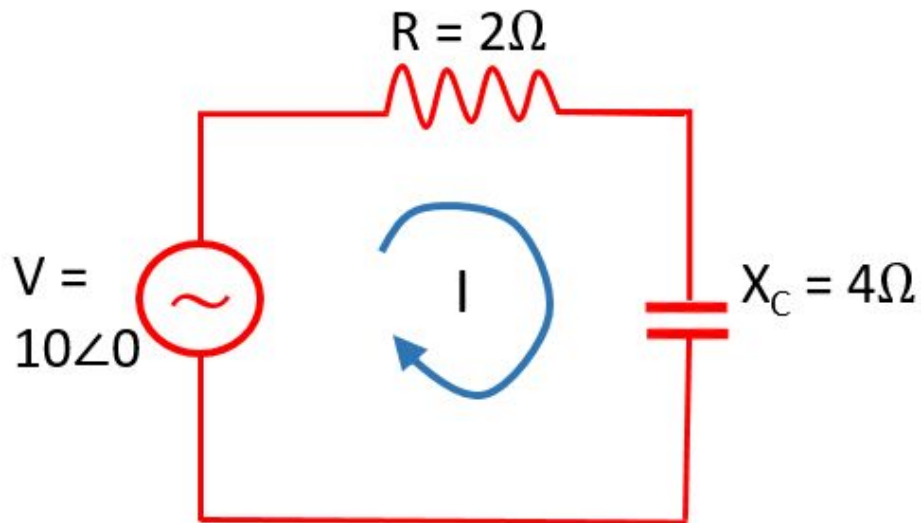

The total impedance of this circuit is $Z = 2 - j4$ (Always remember to multiply X_C by $-j$) and the current and the power factor can be calculated as,

$$I = \frac{V}{Z} = \frac{10}{2 - j4}$$

$$= 1 + j2$$

$$\cos \phi = \frac{R}{|Z|} = 0.44$$

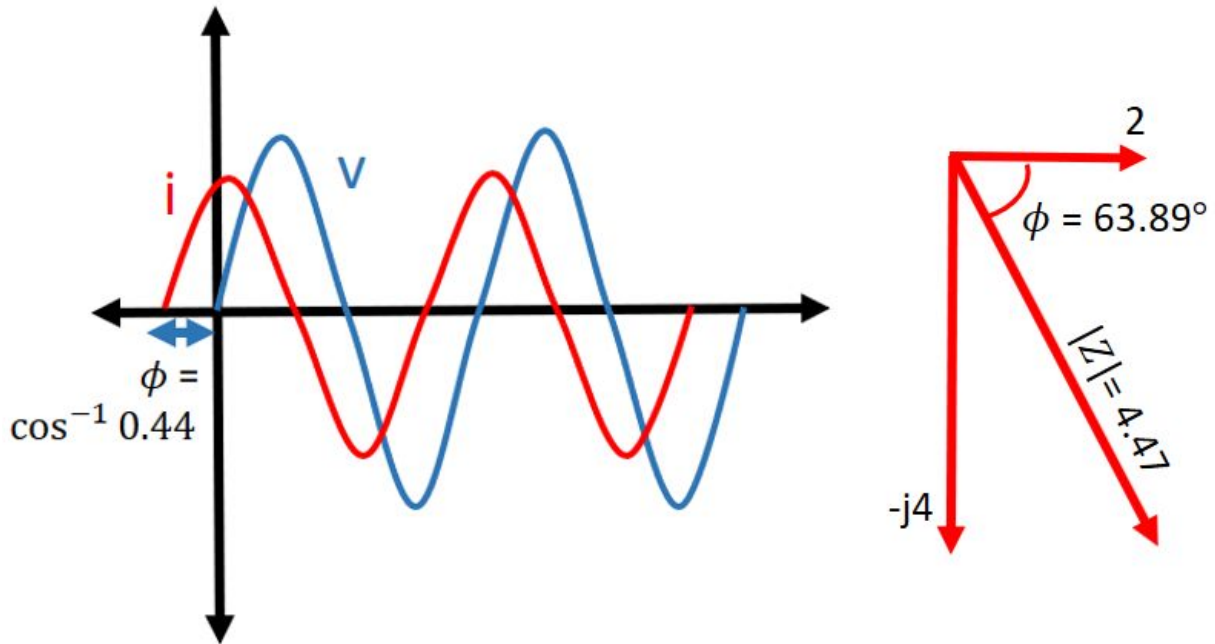

Generally, in an RC series circuit, the current leads the applied voltage by an angle less than 90° . If the resistance is very high compared to capacitive reactance, then the phase difference will be closer to zero and if resistance is negligible, then the phase difference will be close to 90° . In this example, the current leads the voltage by 63.89° .

8.8 SERIES RLC CIRCUIT

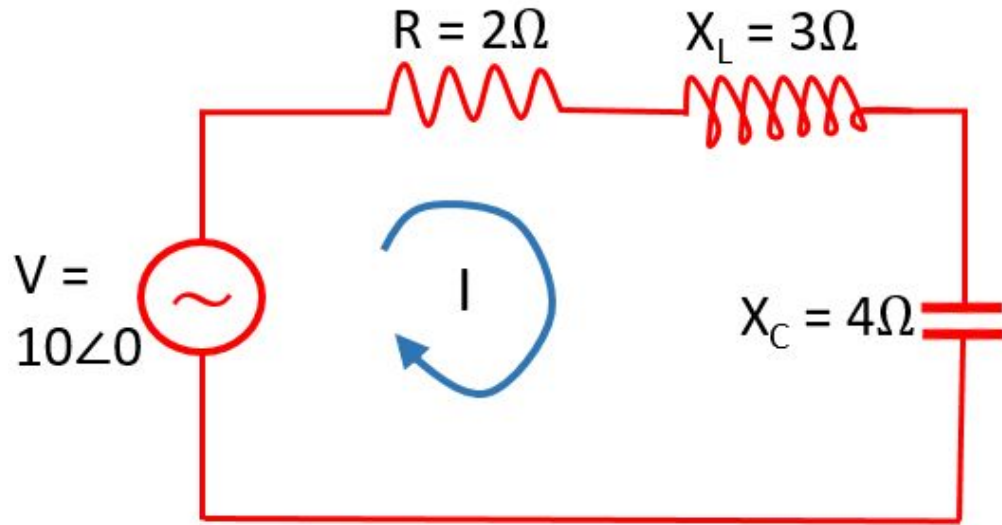

The total impedance of the RLC circuit shown above is $Z = 2 - j$. Hence the power and the power factor can be calculated as:

$$I = \frac{V}{Z} = \frac{10}{2 - j}$$

$$= 4 + j2$$

$$\cos\phi = \frac{R}{|Z|} = 0.89$$

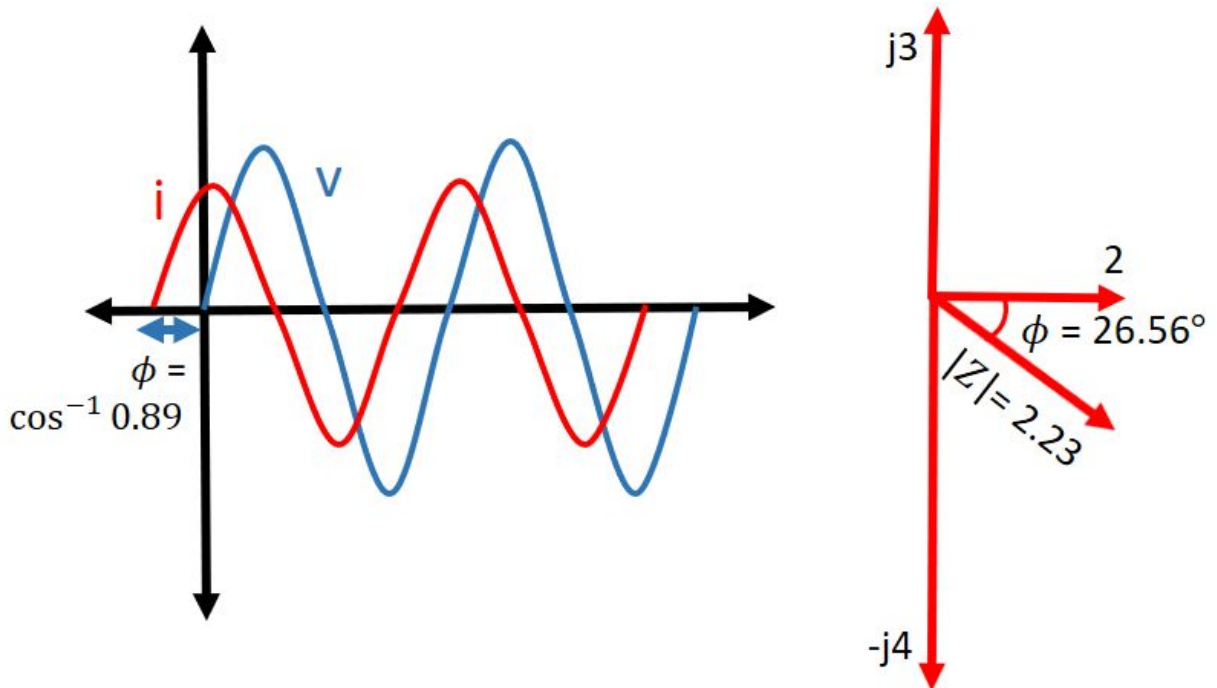

In the RLC circuit, the Inductive reactance and the Capacitive reactance oppose each other. In our example, the capacitive reactance is more than the inductive reactance, hence the current leads the voltage by an angle.

At a certain frequency called the resonance frequency, the inductive reactance and the capacitive reactance become equal. Then the circuit becomes a purely resistive circuit with capacitor-inductor combination acting as a short. At resonance frequency, the capacitor and the inductor exchanges energy back and forth, without effect the rest of the circuit.

9. ANALYSIS TECHNIQUES (FOR AC)

9.1 VOLTAGE DIVIDER RULE

A lot of the laws and theorems used in this chapter and the next chapter are very similar to what we learnt for DC circuits, but there are some differences as well. So we'll go through each of these with the help of examples, rather than repeating the theory. This way you can get better at handling complex number math.

In a series AC circuit, the voltage will be divided amongst the components according to their impedance values, and to find the exact values, we need to use the Voltage divider rule. Consider the RL series circuit shown below. In this circuit the voltage applied by the source is divided amongst the resistor R and an inductor L . The resistor offers an impedance $Z_1 = R$, and the inductor L offers an impedance of $Z_2 = jX_L$ (in rectangular form), where $X_L = \omega L$.

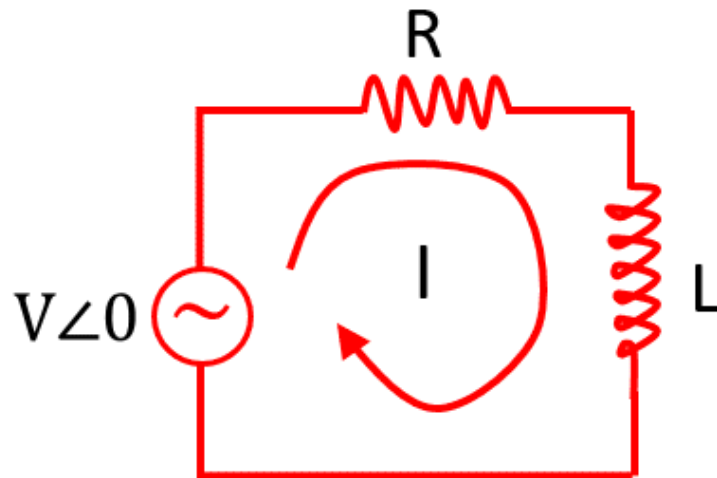

$$I = \frac{V}{(Z_1 + Z_2)}$$

$$\therefore V_R = \frac{VZ_1}{Z_T}, \quad V_L = \frac{VZ_2}{Z_T}$$

In general the Voltage divider rule for AC circuits is,

$$V_x = \frac{VZ_x}{Z_T}$$

Where x is the component whose voltage we want to find out.

9.2 CURRENT DIVIDER RULE

As you already know, the current divider rule is to find the Current division between components in a parallel circuit. This time we'll use a parallel RL

circuit example to derive the result.

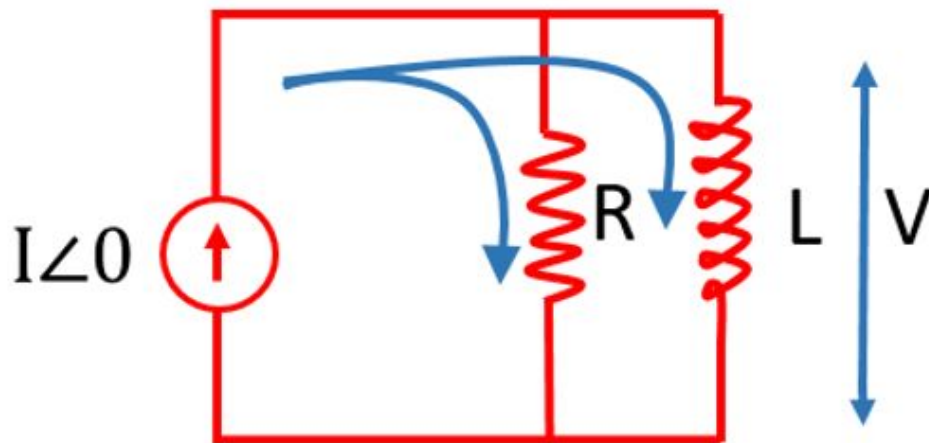

$$V = I Z_T = \frac{I Z_1 Z_2}{(Z_1 + Z_2)}$$

$$\therefore I_R = \frac{I Z_T}{Z_1} = \frac{I Z_2}{(Z_1 + Z_2)}, \quad I_L = \frac{I Z_1}{(Z_1 + Z_2)}$$

In general the Current divider rule for AC is,

$$I_X = \frac{I Z_T}{Z_X}$$

9.3 SOURCE CONVERSION

Just like DC sources, AC voltage sources and AC current sources can also be converted to one another. The process is the same, only difference is that we need to use phasors in this case.

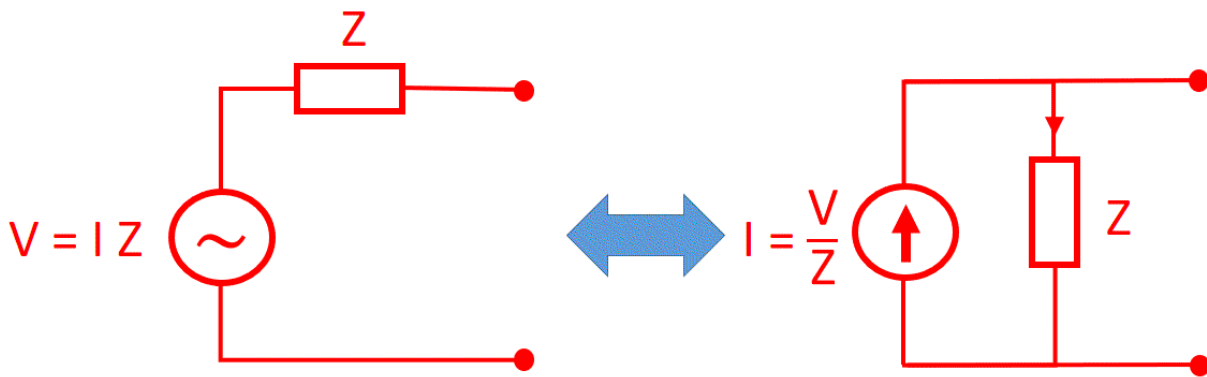

9.4 MESH ANALYSIS

Like we mentioned before, most of these techniques and theorems are same as for DC and only different in math part, so will go through examples for each of them than repeat the theory. Consider the following example:

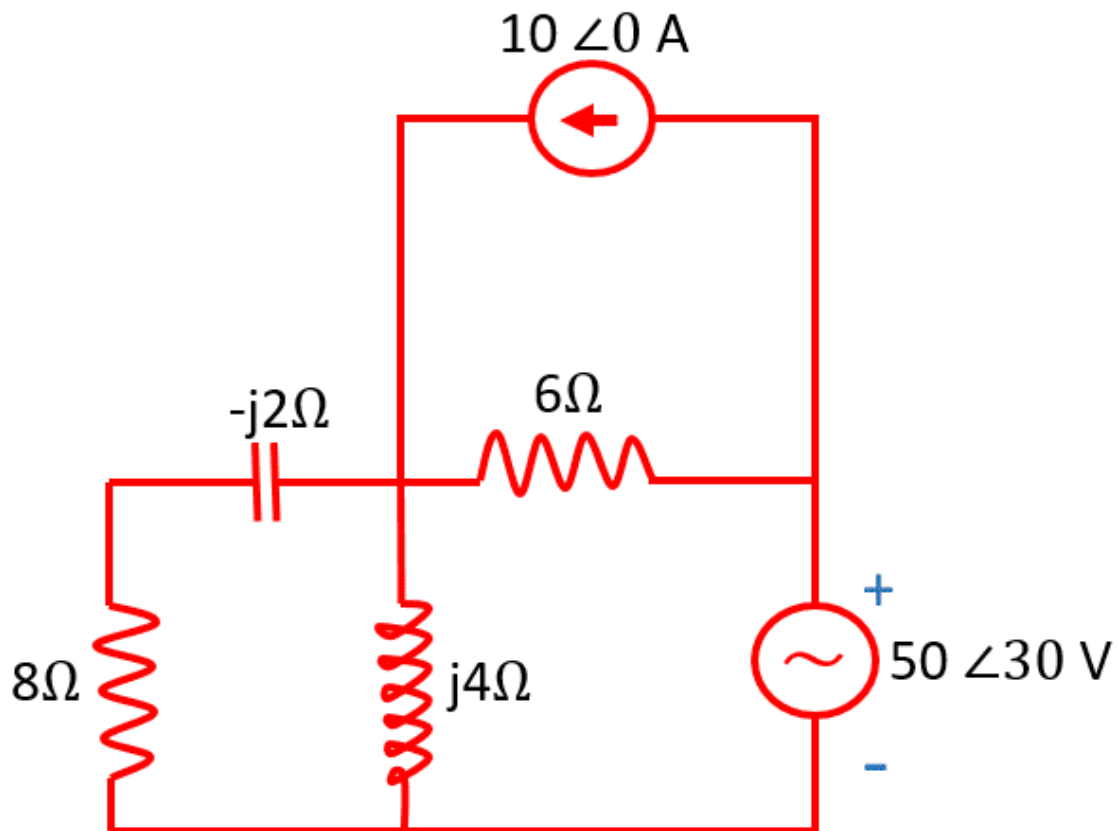

It's easy to see that there are 3 loops or meshes in the circuit. Let's assign a mesh current to each of them and obtain 3 mesh equations using KVL.

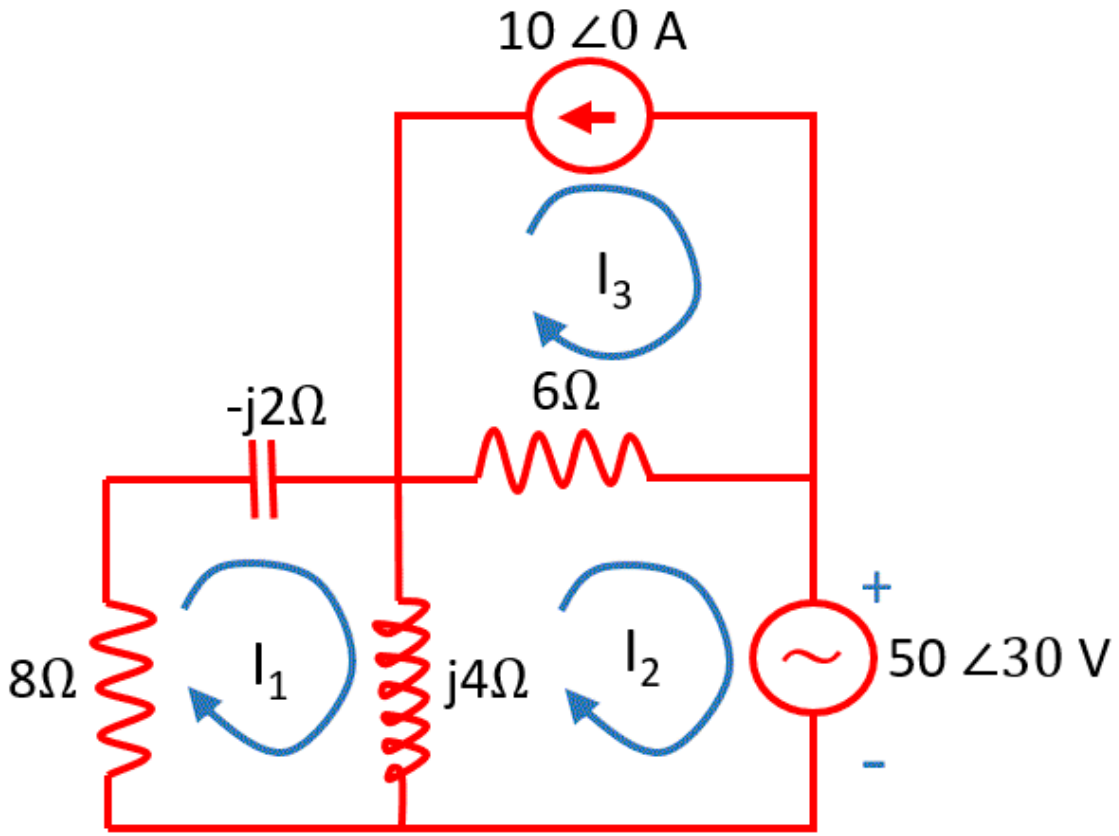

Notice how there is a polarity given to the voltage source. Well, technically AC doesn't have a direction, we know that, but for analysis a direction, which denotes to the direction in the positive half cycle, is often given.

$$\begin{aligned} \text{Mesh 1: } & (8 - 2j + 4j) I_1 - 4j I_2 = 0 \\ & (8 + 2j) I_1 - 4j I_2 = 0 \quad \dots\dots\dots \textcircled{1} \end{aligned}$$

$$\begin{aligned} \text{Mesh 2: } & -4j I_1 + (4j + 6) I_2 - 6 I_3 = -50 \angle 30 \\ & \dots\dots\dots \textcircled{2} \end{aligned}$$

$$\begin{aligned} \text{Mesh 3: } & I_3 = -10 \angle 0 \\ & \dots\dots\dots \textcircled{3} \end{aligned}$$

In mesh 1, current I_1 passes through all the components and current I_2 passes through the inductor $4j$, and because I_2 is in opposite direction to I_1 , the voltage $4jI_2$ has to be subtracted from the equation. Similarly currents I_1 and I_3 has to be considered in mesh 2 along with its mesh current I_2 . Also the current direction we assumed is entering into the positive terminal of the voltage source, hence the negative sign for the voltage source in the equation. Mesh 3 equation is easy because it has a current source, all we need to do is equate I_3 to it (they are in opposite direction though).

It is not necessary to assume mesh currents in clockwise direction, it can be chosen as per your wish, only thing is the equation should be formed accordingly, the results will be the same.

Now the equations can be solved easily using the Cramer's rule, to find the currents.

Converting the quantities to polar form

$$-50\angle 30 = -43.3 - 25j$$

$$-10\angle 0 = -10$$

$$I_1 = \frac{\Delta_1}{\Delta} = \frac{\begin{bmatrix} 0 & -4j & 0 \\ -43.3 - 25j & 4j + 6 & -6 \\ -10 & 0 & 1 \end{bmatrix}}{\begin{bmatrix} 8 + 2j & -4j & 0 \\ -4j & 4j + 6 & -6 \\ 0 & 0 & 1 \end{bmatrix}}$$
$$= -5.969 \angle 65.45^\circ$$

Do note that this circuit can be solved in multiple ways, for instance, converting the current source and the 6Ω resistor to a voltage source, would reduce the circuit to a 2 meshes, which is significantly easier to solve (Sorry it's better to learn the hard way). Concepts like Super Mesh analysis are applicable for AC too.

9.5 NODAL ANALYSIS

Now let's try to solve this circuit using nodal analysis, the procedure is same as with DC.

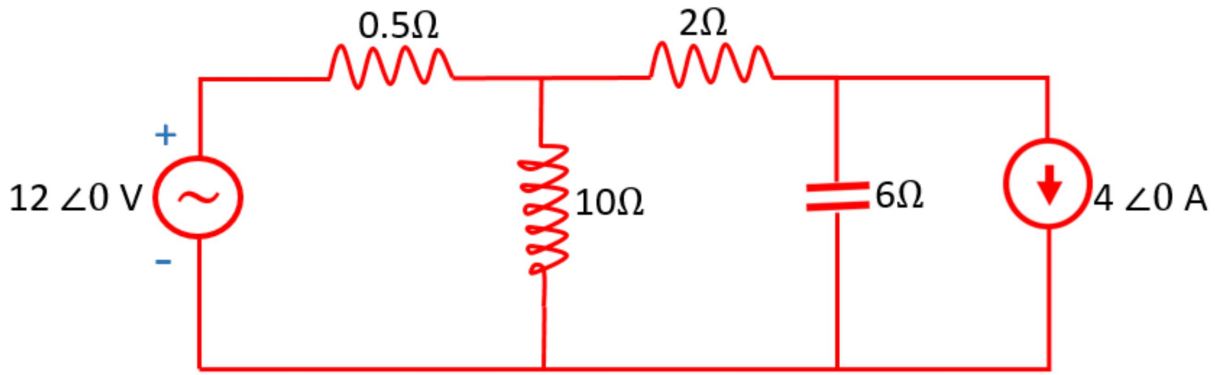

The first step is to identify the nodes and to select a reference node (Remember that node is a point where 2 or more components meet).

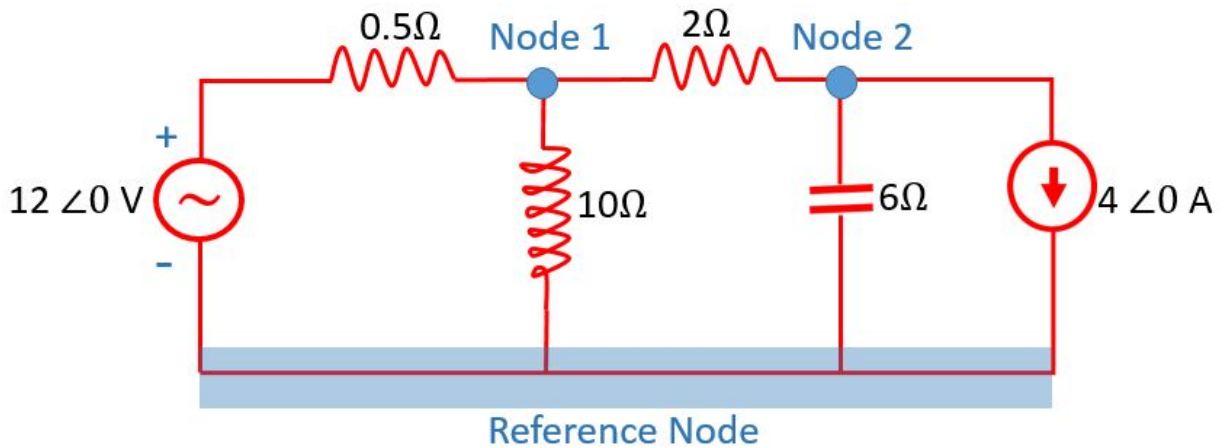

Unlike our last example, the impedance values are not in the complex form, so we to convert them before proceeding further. It's simple, just add j before inductive impedance and add $-j$ before capacitive impedance and leave resistance as such. Then assign voltages to the nodes and use KCL to form equations for each node.

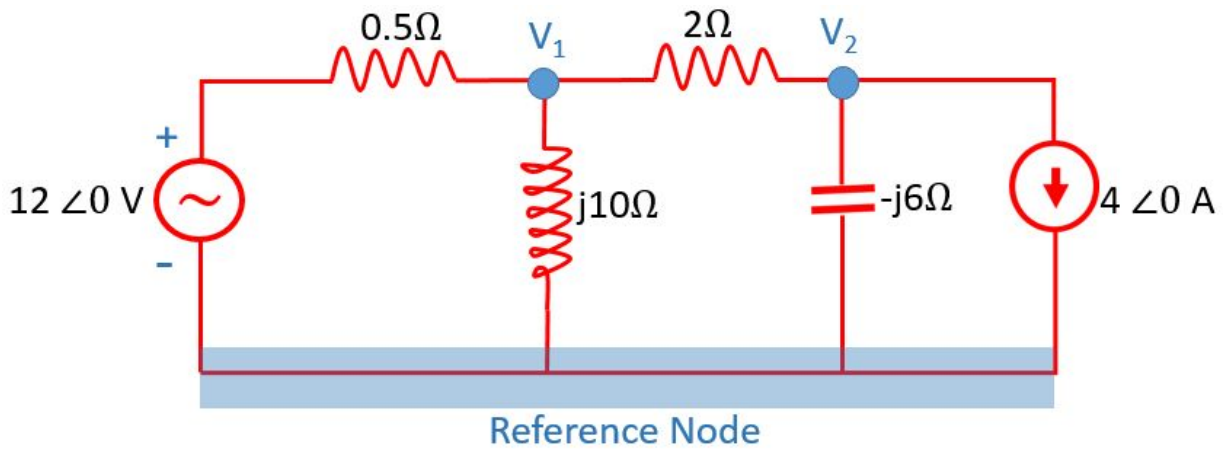

$$\text{Node 1: } \frac{(V_1 - 12 \angle 0)}{0.5} + \frac{V_1}{j10} + \frac{(V_1 - V_2)}{2} = 0$$

$$(25 - j)V_1 - 5V_2 = 240 \quad \dots\dots\dots \textcircled{1}$$

$$\text{Node 2: } \frac{(V_2 - V_1)}{2} + \frac{V_2}{-j6} + 4 = 0$$

$$-3V_1 + (3 + j)V_2 = -24 \quad \dots\dots\dots \textcircled{2}$$

When forming the equations, assume that all currents flow away from the node. After the equations are obtained, proceed as we did in the last example using the crammers rule.

10. NETWORK THEOREMS (FOR AC)

10.1 SUPERPOSITION THEOREM

If you recall correctly, we used the superposition theorem to convert circuits with multiple sources into circuits with single sources. Here too we are doing the same, we are eliminating the other sources in the circuit and analyzing the circuit and repeating the same for the other sources and finally adding up the results.

Consider this example, it has two voltage sources and suppose we are required to find the current through inductor.

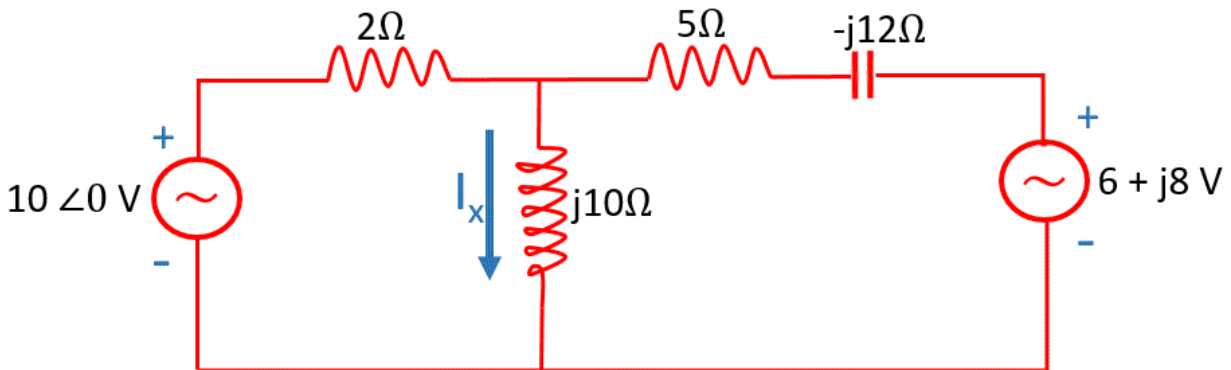

This is an ideal situation to use the superposition theorem, even though this circuit can be solved in plenty ways, including the techniques we learnt so far and the one's we are going to. The first task while using the superposition theorem is to remove the energy sources than the one under consideration. This can be done by shorting the voltage sources and opening the current sources. In this example, we can obtain 2 circuits, as there are 2 sources.

For a while let's consider only the $10\angle 0^\circ$ V source and we get this circuit.

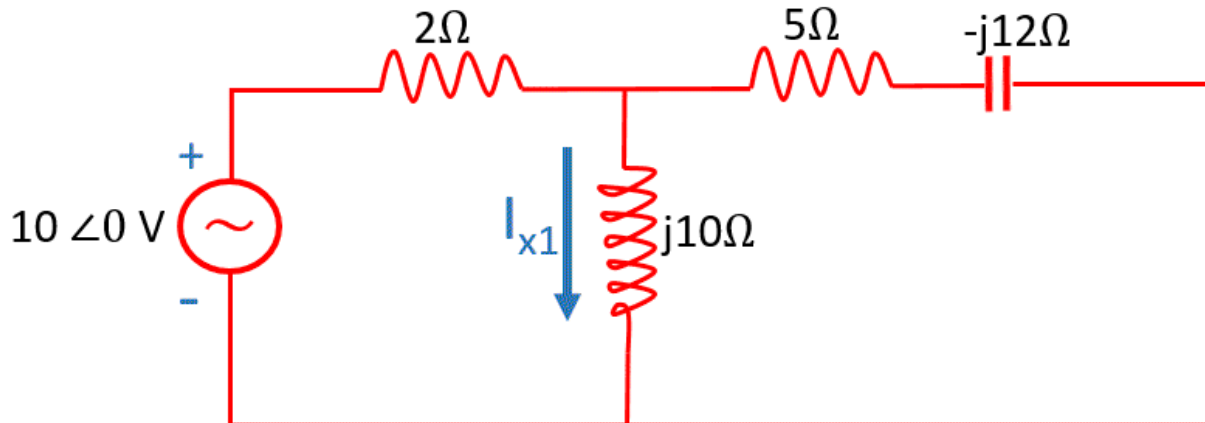

Let's use mesh analysis to solve this circuit.

$$\text{Mesh 1: } (2+j10)I_1 - j10I_2 = 10 \angle 0$$

$$\text{Mesh 2: } -j10I_1 + (5- j2)I_2 = 0$$

Solving the equations we get, $I_1 = 0.29-j0.25$ and $I_2 = 0.24 + j0.68$.

Therefore,

$$I_{x1} = I_1 - I_2 = 0.04 - j0.93$$

Now let's shift our focus to the second voltage source.

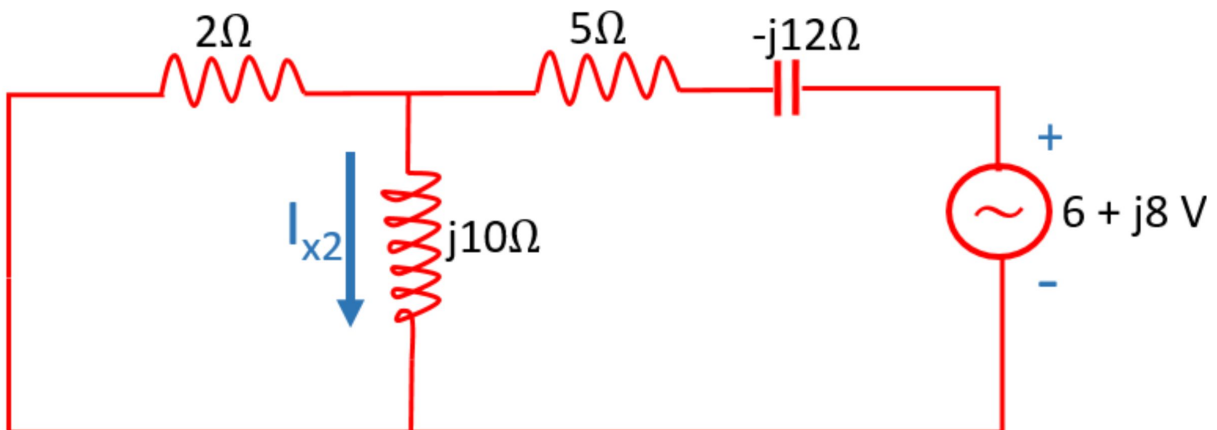

To solve this circuit, let's use ohm's law and KVL.

$$\begin{aligned} Z_T &= \frac{(j10)(2)}{2+j10} + 5 -j12 \\ &= 6.9 -j11.6 \Omega \end{aligned}$$

$$I = \frac{6+j8}{6.9 -j11.6}$$

$$\begin{aligned} I_{x2} &= \frac{6+j8-5+j12}{j10} = \frac{1+j20}{j10} \\ &= 2-j0.1 \end{aligned}$$

Now that we have analyzed the circuits separately, let's combine the results. So the current through the inductor is,

$$I_x = I_{x1} + I_{x2} = 2.04 -j1.03$$

The superposition theorem may seem a little complex and cumbersome, and that's probably true, but nonetheless it's a handy tool to use in analyzing certain types of circuits.

10.2 THEVENIN THEOREM

Thevenin's theorem states that, **any two-terminal, ac network can be replaced by an equivalent circuit consisting of a voltage source and a series impedance.** This is essentially the same as Thevenin's theorem for DC, except that we use Thevenin impedance here.

Consider the circuit shown below, now let's try to find the current through the $4\ \Omega$ resistor. The steps are the same as for DC, but we'll go through them once again.

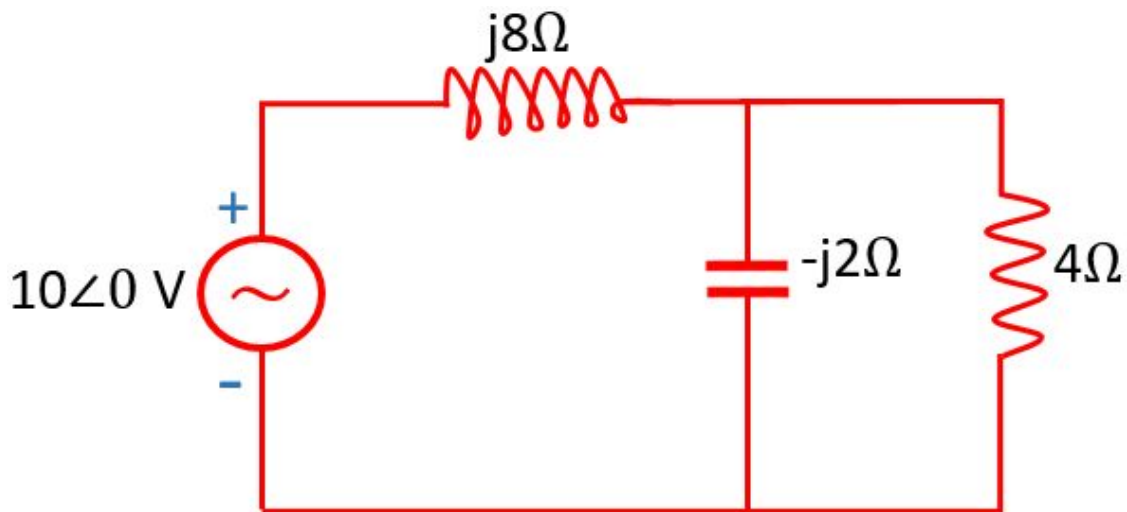

1. Identify the part of the circuit whose equivalent you need to find and then temporarily open circuit the load impedance ($4\ \Omega$ resistor in our case).

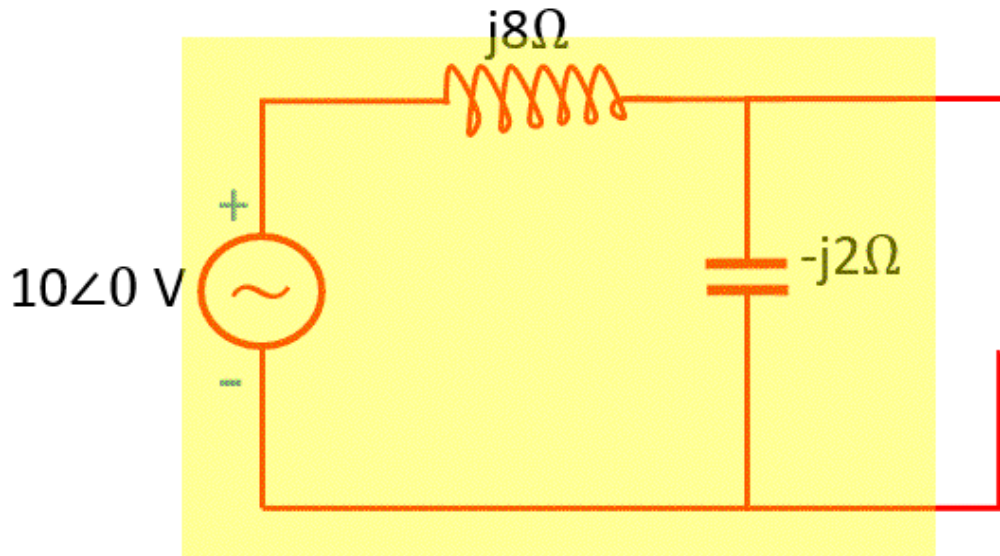

2. To find the Thevenin equivalent Impedance (Z_{TH}), remove all the energy sources in the circuit. This can be done by short circuiting the voltage sources and open circuiting the current sources.

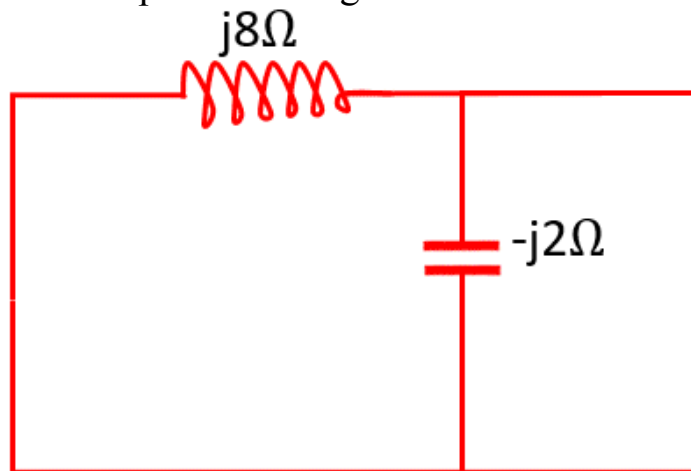

3. Now the equivalent impedance between the terminals will give us the Thevenin equivalent impedance. Here the inductor and the capacitor are in parallel, therefore $Z_{TH} = (j8)(-j2)/(j6) = -2.67j$
4. To find the Thevenin equivalent voltage (V_{th}), energy sources are returned to their original position and then the open circuit voltage across the terminals is determined ($V_{th} = -3.33V$).

5. Finally put the resistor back in its place and we are ready to draw the equivalent circuit.

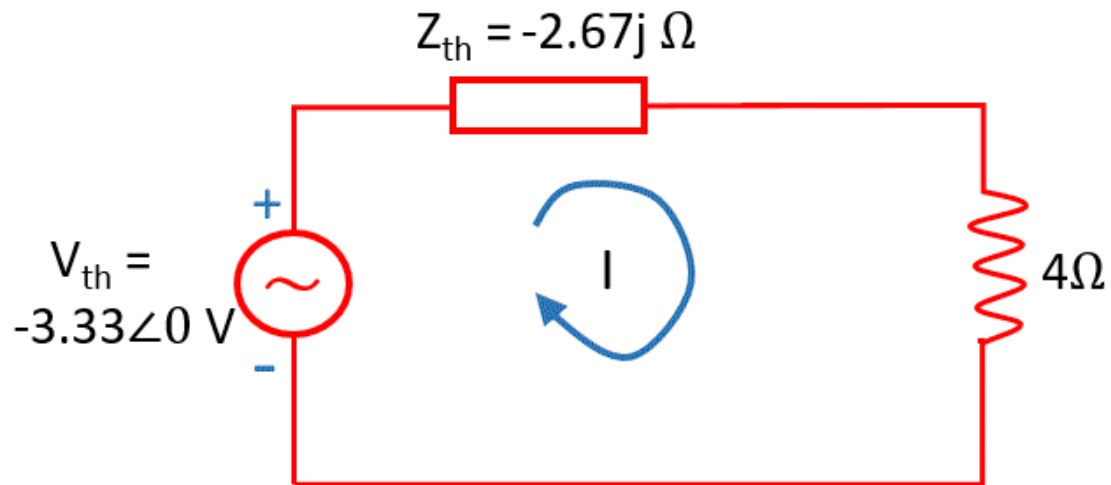

Finding the current through the resistor in this circuit is now a piece of cake ($I = -0.57 - j0.38 \text{ A}$).

10.3 NORTON'S THEOREM

Norton's equivalent circuit is essentially the source transformed version of the Thevenin's equivalent circuit. Using Thevenin's theorem, we could replace a complex portion of a circuit by a voltage source in series with an equivalent impedance, whereas using Norton's theorem, we could replace the circuit by a current source in parallel with an equivalent impedance.

Let's use the Norton's theorem on our last example and spot the similarities between the two theorems.

1. Repeat all the steps and find Z_{th} . Norton's equivalent impedance is same as the Thevenin's equivalent impedance.
2. To find the Norton equivalent current (I_N), energy sources are returned to their original position and then the closed circuit current through terminals is determined.

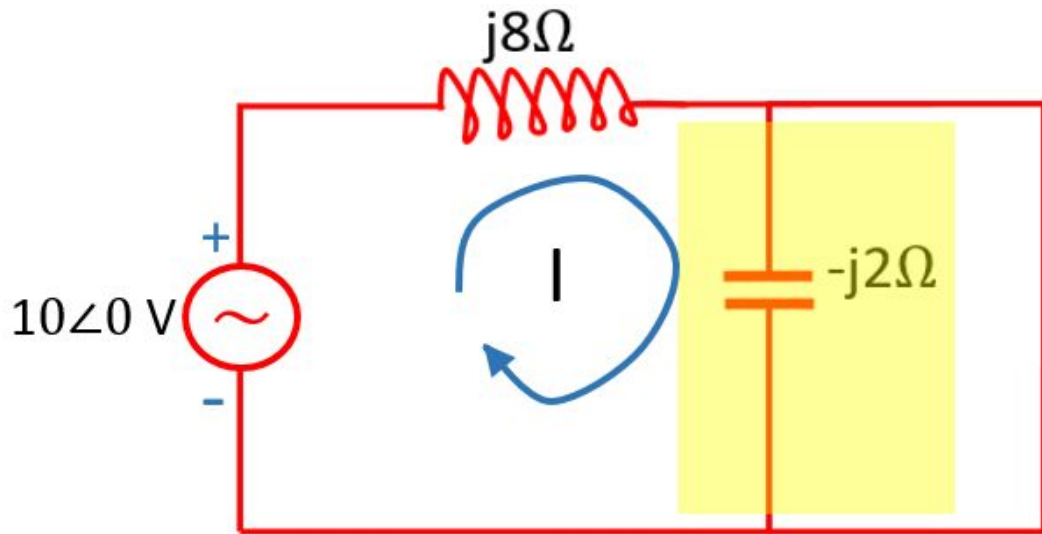

When the load is shorted, the capacitor is also shorted out. Hence the Norton equivalent current is given by $I_N = 10/j8 = -1.25j$

3. Finally put the resistor back in its place and we are ready to draw the equivalent circuit.

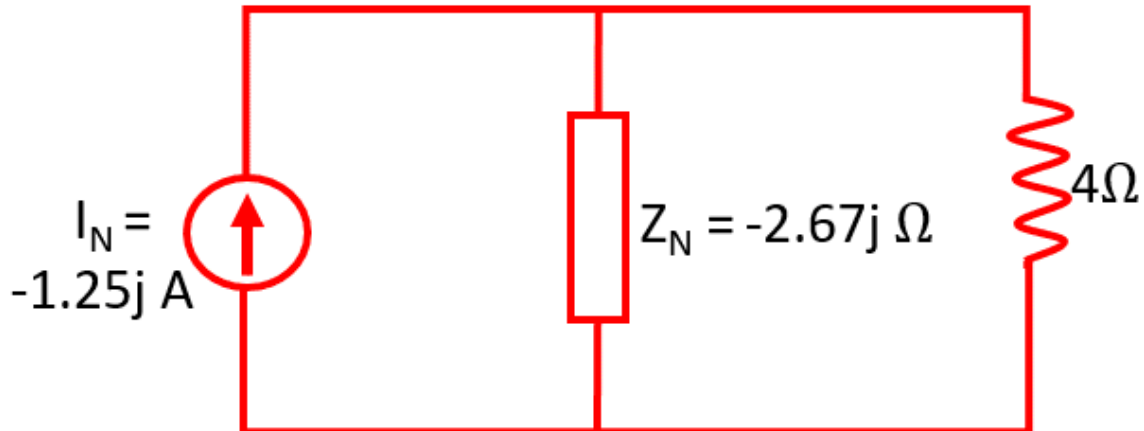

The current through the resistor can be found using the Current division rule. $I = (-1.25j)(-2.67j)/(4-2.67j) = -0.57-j0.38$ A, which is exactly the value we obtained using the Thevenin's theorem.

10.4 MAXIMUM POWER TRANSFER THEOREM

All the theorems stated so far were pretty much the same as for DC, but this theorem is slightly different, the idea is the same, the math part is significantly different.

Maximum Power Transfer Theorem for AC states that, **maximum power will be delivered to a load when the load impedance is the conjugate of the Thevenin impedance across its terminals.** The statement is all sorts of confusing, where did the conjugate term come from? Let's try to prove this theorem our self to get a better understanding.

Suppose we reduced a random circuit to its Thevenin's equivalent and connected a load impedance across it, we get a circuit like this.

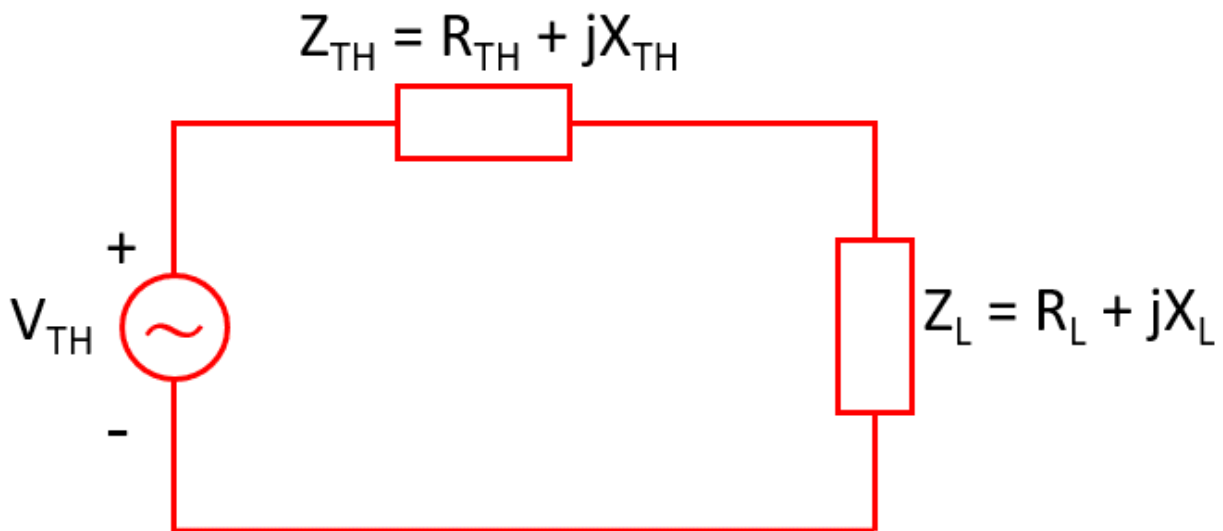

The current through this circuit will be,

$$I = \frac{V_{TH}}{Z_{TH} + Z_L} = \frac{V_{TH}}{R_L + R_{TH} + j(X_L + X_{TH})}$$

Hence the power delivered to the load impedance is given by,

$$P_L = \frac{V_{TH}^2 R_L}{(R_L + R_{TH})^2 + (X_L + X_{TH})^2}$$

Notice how there is only R_L term in the numerator and the X_L term is missing, that's because the reactive part of the impedance doesn't consume any power over the full cycle. To get the condition for max power, we need to differentiate the P_L with respect to X_L (I'm not going to, but you should) and equate it to zero. Then we get the condition $X_{TH} + X_L = 0$ i.e. $X_L = -X_{TH}$. Substituting this relation in the power equation, we obtain a simpler expression.

$$P_L = \frac{V_{TH}^2 R_L}{(R_L + R_{TH})^2}$$

To get the next condition for maximum power transfer, differentiate the P_L once again, this time with respect to R_L and equate it to zero, it's much easier this time. This time we get the condition $R_L + R_{TH} = 2R_L$ i.e. $R_L = R_{TH}$.

So the two conditions for Maximum power transfer in AC circuits is,

$$R_L = R_{TH} \quad \& \quad X_L = -X_{TH}$$

Combining the 2 we get,

$$Z_L = R_L + jX_L = R_{TH} - jX_{TH}$$

$$\therefore Z_L = Z_{TH}^*$$

To sum up, maximum power can be transferred from source to the load in an AC circuit, if the resistive part of the source and the load are the same and the reactive parts cancel each other out.

11. LAPLACE TRANSFORM

11.1 INTRODUCTION

So far we dealt with DC circuits and sinusoidal AC circuits in steady state (more on this in the next chapter). But in most real life circuits, the sources may not always be sinusoidal and quantities of interest in these circuits may be in transient state etc. So the math we used so far will prove inadequate to deal with these circuits. The way to deal with such circuits is to model them with the help of differential equations.

Perhaps an example will make things more clear.

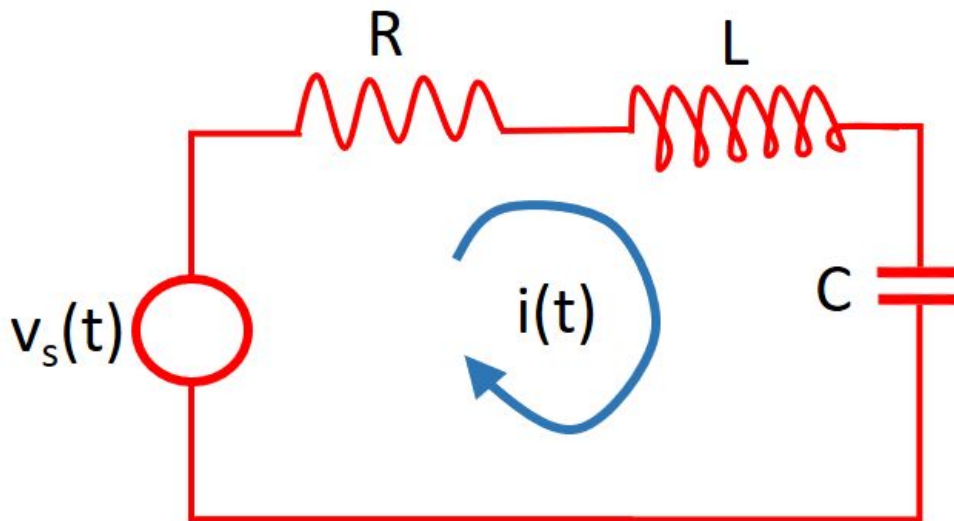

Consider this simple RLC circuit with a voltage source $v_s(t)$ and suppose the current through the circuit is the quantity of our interest. Using KVL, $v_s(t) = v_R + v_L + v_C$. The voltage across each component can be replaced by the relations shown in the table below (memorize this table). This is done to make each term a function of current $i(t)$, which is common to all components, as this is a series circuit.

Component	Voltage across the component	Current through the component
Resistor	$v_R = i_R R$	$i_R = \frac{v_R}{R}$
Inductor	$v_L = L \frac{di_L}{dt}$	$i_L = \frac{1}{L} \int v_L dt$
Capacitor	$v_C = \frac{1}{C} \int i_C dt$	$i_C = C \frac{dv_C}{dt}$

Now the KVL equation becomes:

$$v_s(t) = R i(t) + L \frac{di(t)}{dt} + \frac{1}{C} \int i(t) dt$$

To remove integral, differentiate both sides,

$$\frac{dv_s(t)}{dt} = R \frac{di(t)}{dt} + L \frac{d^2 i(t)}{dt^2} + \frac{1}{C} i(t)$$

This is the differential equation for this particular circuit. There are lots of advantages to modelling circuits this way. For one, this equation is a general one, it is applicable to any kind of source voltage, DC or sinusoidal AC or any other waveform. Also a lot of inferences can be made just from the nature of the differential equation. For instance, the equation in our example is a second order differential equation and that is enough information to predict the general behavior of this circuit to various inputs.

The only problem with this method is that, solving differential equations isn't the easiest of tasks and not everyone's an expert in calculus. But luckily there's an easier way to solve differential equations, using Laplace transform.

11.2 LAPLACE TRANSFORM

The Laplace transform is a well-established mathematical technique for solving differential equations. It is named in honor of the great French mathematician, [Pierre Simon De Laplace](#). Like all transforms, the Laplace transform changes a mathematical function into another according to some fixed set of rules or equations.

Before we dig into Laplace transform, let's look into transforms in general. So what is a transform? Why do we need them?

Let's begin by considering a simple computational problem: compute the value of $x = 3.4^{2.4}$. It is not easy to get the exact value using straightforward methods. What we can do to make this problem solvable is to take natural log on both sides: now the equation becomes $\ln(x) = 2.4 \ln(3.4)$. Now the value of $\ln(x)$ can be easily obtained from a log table. And to obtain the value of x , all we have to do is to take the antilog of the value obtained. What we did was to take the hard problem, convert it into an easier equivalent problem. This is the very idea behind transforms. The concept of transformation can be illustrated with the simple diagram below:

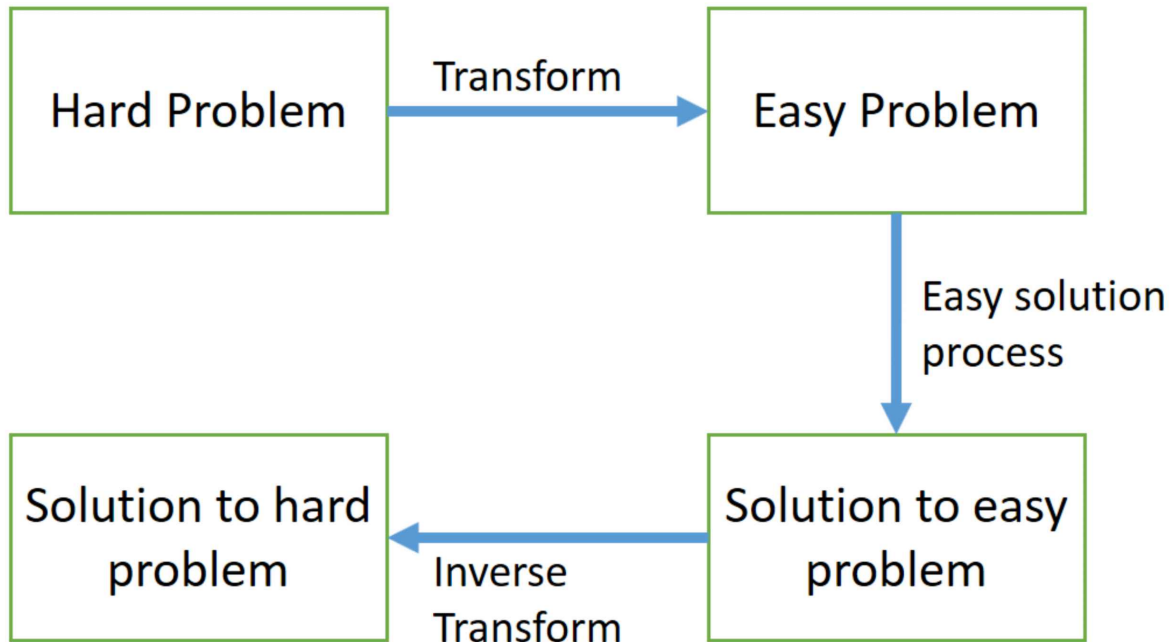

What kind of transformation might we use with ODEs? Based on our experience with logarithms, the dream would be a transformation, it would be useful if some transformation allowed us to replace the operation of differentiation by some easier operation, perhaps something similar to multiplication. This is exactly what the Laplace transform is used for. The Laplace transform, transforms the differential equations into algebraic equations which are easier to manipulate and solve. Once the solution in the Laplace transform domain is obtained, the inverse Laplace transform is used to obtain the solution to the differential equation.

The Laplace transform of a function $\mathbf{f(t)}$, denoted as $\mathbf{F(s)}$, is defined as:

$$F(s) = \int_0^{\infty} f(t)e^{-st} dt$$

This equation looks menacing at first glance. But fortunately, most times you don't need to use this equation, you can easily get away with knowing some standard results and some properties.

11.3 PROPERTIES OF LAPLACE TRANSFORM

Some of the basic properties of Laplace transform are listed here,

Property	Operation in time domain	Operation in s domain
Linearity	$a_1 x_1(t) + a_2 x_2(t)$	$a_1 X_1(s) + a_2 X_2(s)$
Differentiation	$\frac{d^n x(t)}{dt^n}$	$s^n X(s) - s^{n-1} x(0^-) \dots - x^{n-1}(0^-)$
Integration	$\int_{-\infty}^t x(\tau) d\tau$	$\frac{X(s)}{s} + \frac{x^{n-1}(0^-)}{s}$
Initial value theorem	$x(0) = \lim_{t \rightarrow 0} x(t)$	$x(0) = \lim_{s \rightarrow \infty} sX(s)$
Final value theorem	$x(\infty) = \lim_{t \rightarrow \infty} x(t)$	$x(\infty) = \lim_{s \rightarrow 0} sX(s)$
Time scaling	$x(at)$	$a^{-1} X\left(\frac{s}{a}\right)$

11.4 STANDARD LAPLACE TRANSFORM PAIRS

f(t)	F(s)
1	$\frac{1}{s}$
Constant K	$\frac{K}{s}$
t	$\frac{1}{s^2}$
t ⁿ	$\frac{n!}{s^{n+1}}$
e ^{-at}	$\frac{1}{s+a}$
e ^{at}	$\frac{1}{s-a}$
e ^{-at} t ⁿ	$\frac{n!}{(s+a)^{n+1}}$
sin ω t	$\frac{\omega}{s^2+\omega^2}$
cos ω t	$\frac{s}{s^2+\omega^2}$
e ^{-at} sin ω t	$\frac{\omega}{(s+a)^2+\omega^2}$
e ^{-at} cos ω t	$\frac{(s+a)}{(s+a)^2+\omega^2}$

11.5 INVERSE LAPLACE TRANSFORM

Finding the Inverse Laplace transforms of functions isn't terribly difficult. Most times Inverse Laplace transforms of functions can be figured out by inspection. The general method to find the Inverse Laplace transforms of functions is to express them as partial fractions and then make it into a convenient form and figure out which function's Laplace each term is. Keeping the various properties of Laplace transform is very handy.

Here are some examples on finding Laplace Inverse: [Link](#)

11.6 SOLVING DIFFERENTIAL EQUATIONS

We started with Laplace transform as an easier method to solve differential equations. The procedure is best illustrated with an example.

Example:

$$f''(t) + 3f'(t) + 2f(t) = e^{-t}, \text{ with the initial conditions } f(0) = 0 \\ f'(0) = 0$$

$$f''(t) + 3 f'(t) + 2 f(t) = e^{-t}$$

$$s^2 F(s) + 3s F(s) + 2 F(s) = \frac{1}{s+1}$$

Taking Laplace
transform on both
sides

$$F(s) = \frac{1}{s+1} - \frac{1}{s^2+3s+2}$$

Decomposing into partial fractions,

$$F(s) = \frac{1}{s+2} - \frac{1}{s+1} + \frac{1}{(s+1)^2}$$

$$f(t) = e^{-2t} - e^{-t} + te^{-t}$$

Taking Inverse Laplace
transform on both
sides

At first glance, this may not seem any better than differential equations, but trust us, using Laplace transform is very easy with some practice. Here are more examples to practice: [Link](#)

11.7 MODELLING CIRCUITS IN S-DOMAIN

Once you gain enough confidence with Laplace transform, you don't have to find the differential equations for the circuits, then convert it into Laplace transform. Instead you can form algebraic equations in the Laplace domain or the s-domain, directly by inspection.

Voltage or current in an element in the circuit can be represented as given in the table below. These are just the Laplace transforms of the relations from the earlier table. With the differentiation and integration gone, the relations look easier already. We have ignored the initial states of the components in these relations (That's for the next chapter).

Component	Voltage across the component	Current through the component
Resistor	$V(s) = I(s) R$	$I(s) = \frac{V(s)}{R}$
Inductor	$V(s) = sL I(s)$	$I(s) = \frac{V(s)}{sL}$
Capacitor	$V(s) = \frac{I(s)}{sC}$	$V(s) = sC I(s)$

Now we'll try to model a circuit in the Laplace domain directly. What better than our circuit from earlier, to try this out.

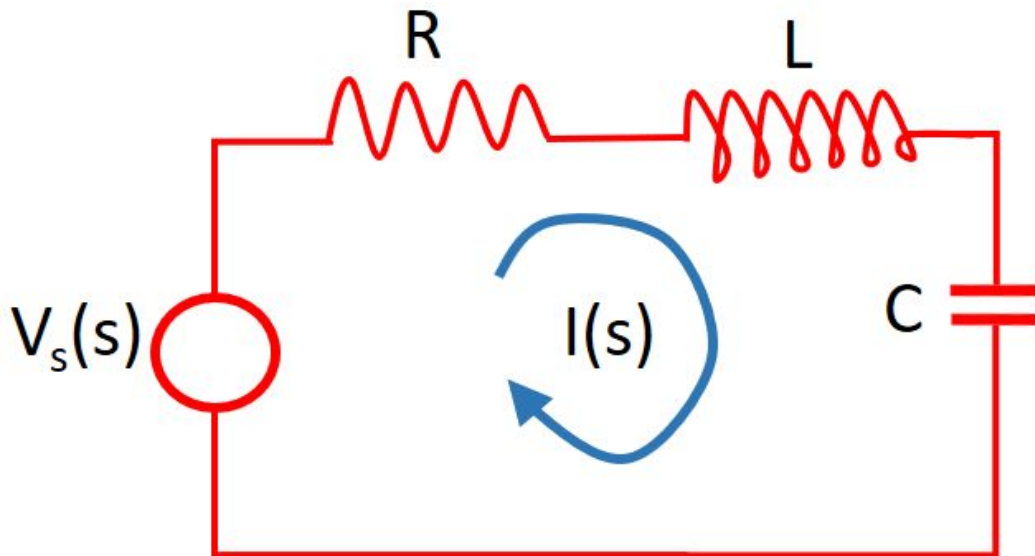

Using KVL,

$$V_s(s) = R I(s) + sL I(s) + \frac{I(s)}{sC}$$

$$\Rightarrow sC V_s(s) = I(s) [sRC + s^2LC + 1]$$

$$\therefore I(s) = \frac{sC}{LCs^2 + RCs + 1} V_s(s)$$

Modelling circuits in the s-domain has lots of advantages, it's easier to study stability, natural response, frequency response etc., but that's more of a control systems terro and we are not going into it. You can check out our control systems book if you are interested: [Control Systems for Complete Idiots](#)

12. TRANSIENT ANALYSIS

12.1 INTRODUCTION

A circuit whose circuit parameters or conditions remain constant, is said to be in a steady state. But a circuit isn't always in steady state, when a circuit or a portion of the circuit is switched on or off, there is a sudden change in circuit parameters (like amplitude, frequency etc.). A certain amount of time is taken for these changes to take place, this duration is called the Transient period and this phenomenon is known as Transient. Once the transient period is over, the circuit settles down and attains the steady state, if not disturbed further.

So when you switch on a circuit, there are 2 responses; one is the transient response or the natural response and the other is the steady state response or the forced response. All the circuit analysis we did till now was to find the steady state response, we ignored the transient response. Transients are due to the presence of energy storing elements (Capacitors and Inductors) in a circuit. These elements don't respond instantly to change in circuit conditions.

12.2 TRANSIENT RESPONSE OF AN RL CIRCUIT TO DC EXCITATION

Consider this initially uncharged inductor in series with a resistor. At $t=0$, the switch S is closed. Being an initially uncharged inductor, the current before the instant of closing, $i(0^-)$ is zero. But as the inductor cannot quickly respond to the change in current, the current at the instant right after the closing of the switch, $i(0^+)$ is also zero i.e.

$$i(0^-) = i(0^+) = 0$$

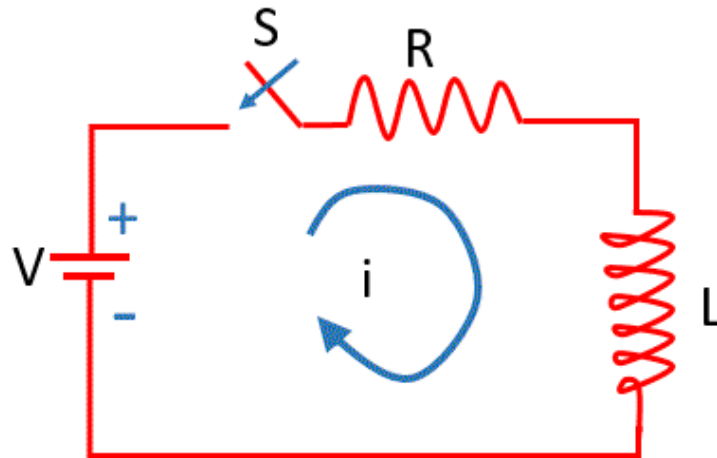

Then the current that flows through the circuit can be found using differential equation. Using KVL,

$$V = iR + L \frac{di}{dt}$$

This is a simple first order differential equation and can be solved easily, but we'll go with the Laplace transform approach. Do not forget to include the initial value terms in the Laplace transform of the differential.

Taking Laplace on both sides,

$$\frac{V}{s} = R I(s) + L[sl(s) - i(0^-)]$$

$$\Rightarrow I(s) = \frac{V}{s[R + Ls]}$$

Writing the RHS as partial fraction,

$$I(s) = \frac{V}{R} \left[\frac{1}{s} - \frac{1}{s + R/L} \right]$$

$$\therefore i(t) = \frac{V}{R} - \frac{V}{R} e^{-Rt/L}$$

Steady state
response

Transient
response

The equation just validates our discussion, that circuits have 2 responses, steady state and transient. As t increases the transient response term decreases exponentially and nullifies, leaving only the steady state response. If you go by the methods used prior to this chapter, current value by ohms law will give the result $I = V/R$, which is our steady state response.

The graph of the current response of this circuit will look like this:

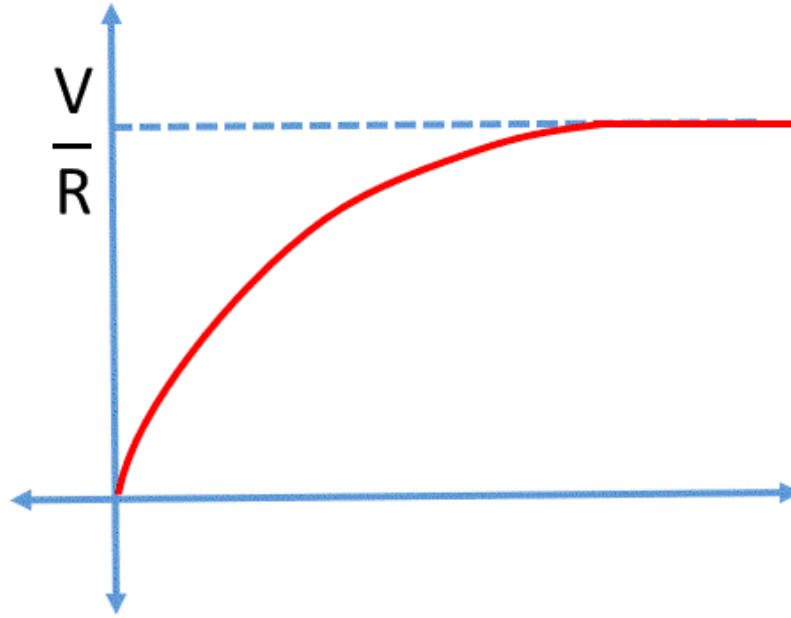

The constant $\tau = L/R$ is called the time constant of the circuit. This value decides how fast this circuit will reach steady state. Typically current will reach steady state after $t = 5\tau$. The important thing to note is that after the brief transient period, Inductor acts as a short circuit (just like a normal wire) in a DC circuit.

12.3 TRANSIENT RESPONSE OF AN RC CIRCUIT TO DC EXCITATION

This time consider an initially uncharged capacitor in series with a resistor. At $t=0$, the switch S is closed. As the capacitor cannot quickly respond to the change in voltage, the voltage before and right after the closing of the switch are the same i.e.

$$v_C(0^-) = v_C(0^+) = 0$$

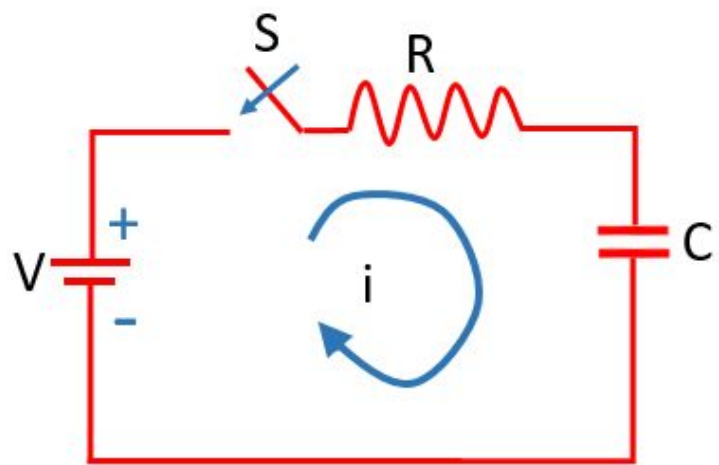

Current through the circuit,

$$i(t) = C \frac{dv_C}{dt}$$

$$I(s) = C [sV_C(s) - v_C(0^-)] \\ = Cs V_C(s) \dots\dots\dots \textcircled{1}$$

Using KVL,

$$\frac{V}{s} = R I(s) + V_C(s) \dots\dots\dots \textcircled{2}$$

Substituting $\textcircled{2}$ in $\textcircled{1}$

$$\frac{V}{s} = RCs V_C(s) + V_C(s)$$

$$V_C(s) = \frac{V}{s[RCs + 1]}$$

$$\therefore v_C(t) = V - Ve^{-t/RC}$$

Steady state
response

Transient
response

This is the generalized expression for $v_C(t)$ and the corresponding graph looks like:

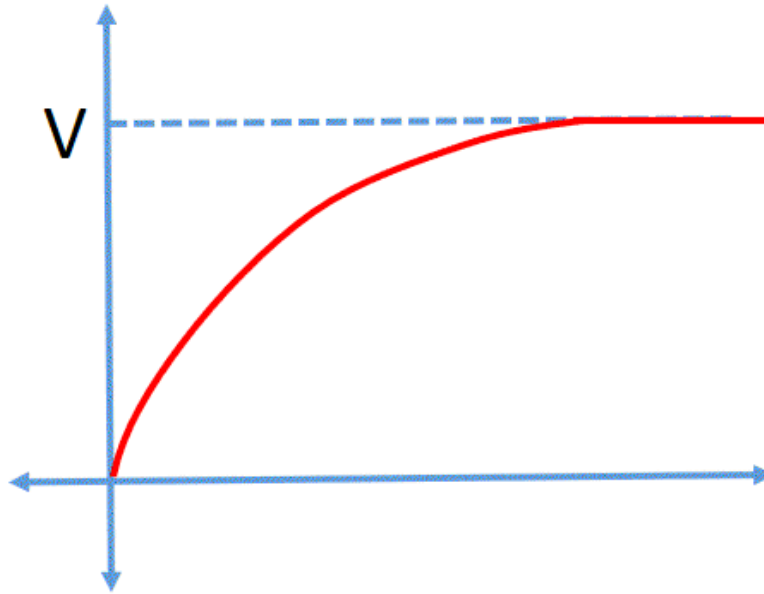

The constant $\tau = RC$ is the time constant of this circuit. In a DC circuit, the capacitor acts as an open circuit in the steady state.

12.4 EXAMPLE

Using a similar approach like in the last two cases, we can obtain the general response for any circuit.

Consider this example, say the switch has been in position 1 for a long time and then it's moved to position 2 at $t=0$ and we are required to find the voltage across the capacitor.

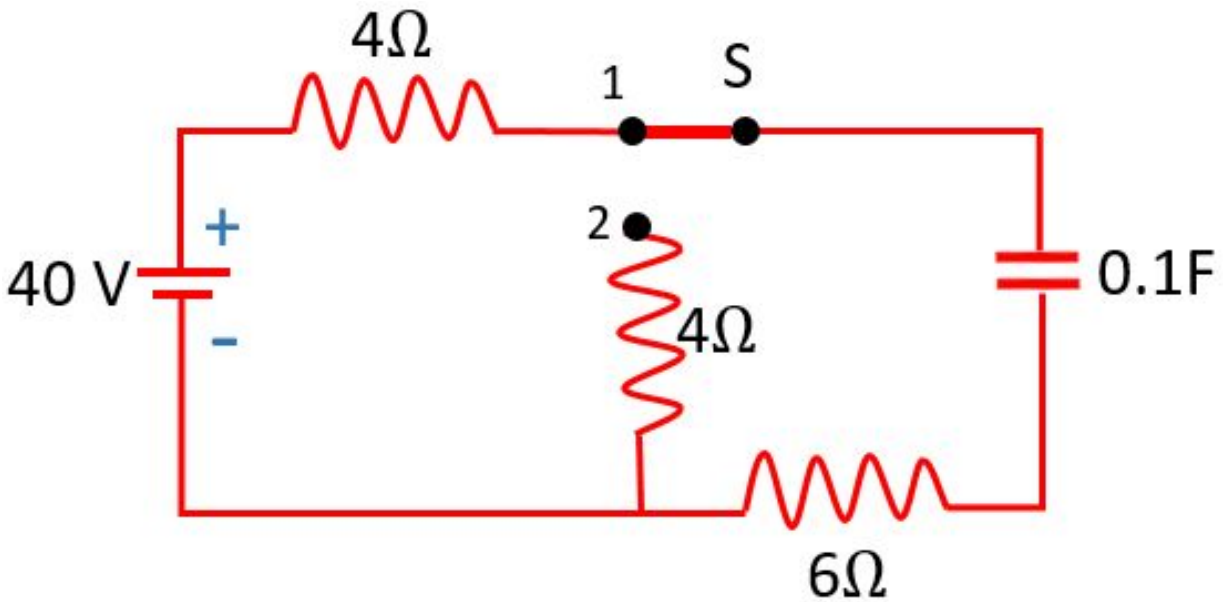

Since the switch has been in position 1 for a long time it's in the steady state, hence the initial voltage across the capacitor will be equal to the applied voltage.

$$v_C(0^-) = v_C(0^+) = 40V$$

In position 2,

$$i(t) = C \frac{dv_C}{dt} = 0.1 \frac{dv_C}{dt}$$

Using KVL,

$$v_C + i(t) [R_1 + R_2] = 0$$

Taking Laplace transform on both sides,

$$V_C(s) + 10 \times 0.1 [sV_C(s) - v_C(0^-)] = 0$$

$$V_C(s) + s V_C(s) - 40 = 0$$

$$V_C(s) = \frac{40}{(1 + s)}$$

$$\therefore v_C(t) = 40e^{-t}$$

Similarly, the general response for any type of circuits including AC circuits can be found.

13. 3-PHASE SYSTEMS

13.1 INTRODUCTION

There are 2 popular kinds of electrical systems, Single phase and Three phase. In a single phase system, there will be live wire and a neutral return path for the current to flow. In a three phase system, there will be 3 live wires and a common neutral return path for the current. There are several advantages to having 3 phase system over single phase; more power can be delivered, cheaper to generate, transmit etc.

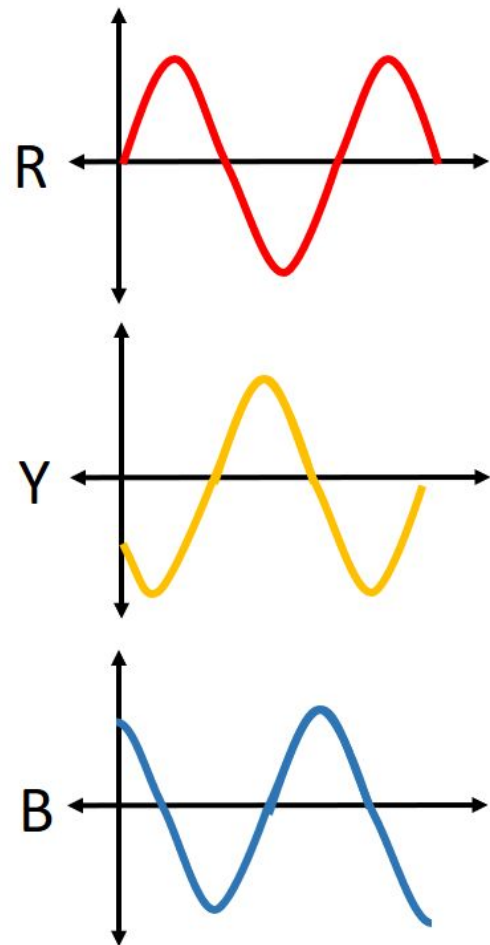
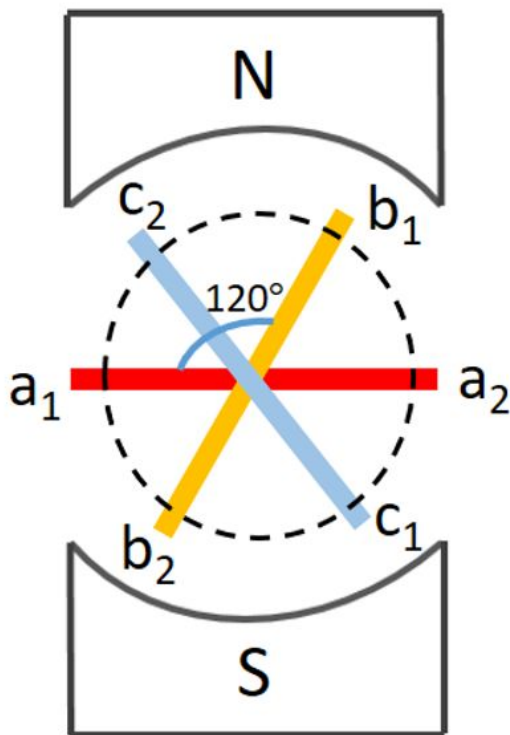

Three phase voltage is generated with the help of 3 coils separated by 120° inside a generator. Due to this arrangement, the voltage induced on each coil will lag the other by 120° . Mathematically,

$$v_R = V_m \sin(\omega t)$$

$$v_Y = V_m \sin(\omega t - 120^\circ)$$

$$v_B = V_m \sin(\omega t - 240^\circ)$$

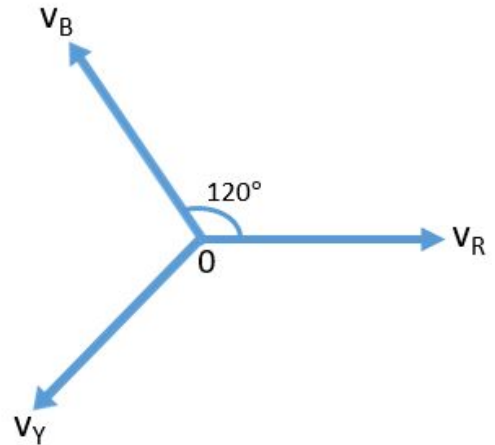

13.2 STAR CONNECTION

In a single phase connection, 2 wires are sufficient for transmitting power to the load. But in a 3 phase connection, 6 terminals (2 ends of each phase) are available to supply power to the loads. Using these 6 terminals individually, like in single phase connection will prove expensive and unnecessary. There are 2 better ways to connect three phase terminals to deliver power to the loads.

First is the Star or the Wye Connection. In such a connection, one terminal of each coil is terminated at a common point called the neutral. Loads can be connected either between the phases or between the phase and the neutral.

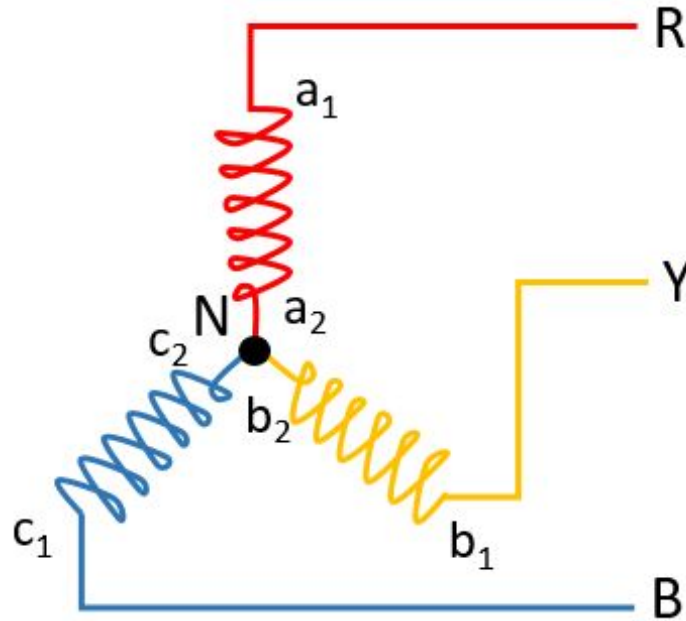

13.3 DELTA CONNECTION

Another possible way to connect coils is the Delta Connection. In such a connection, the ending terminal of a coil is connected to the starting terminal of the other coil, so as to form a closed loop as shown below. In delta connection there is no common neutral point, so the only way to connect load is between the phases.

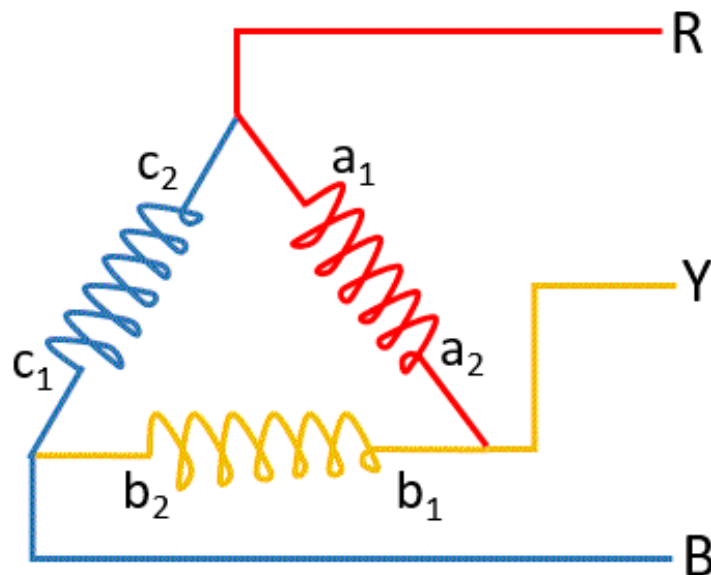

13.4 LINE & PHASE VOLTAGE

While studying 3 ϕ circuits, two types of voltages can be defined; line voltage and phase voltage (this applies for both connections). The potential difference or voltage between any two phases is defined as the line voltage. It is denoted as V_L . And the potential difference between any one phase and neutral is called phase voltage. It is denoted as V_{ph} .

In a delta connection, there is no neutral point, hence the line voltage and the phase voltage are the same. But in star connection, these are two different quantities, whose relation can be derived as follows:

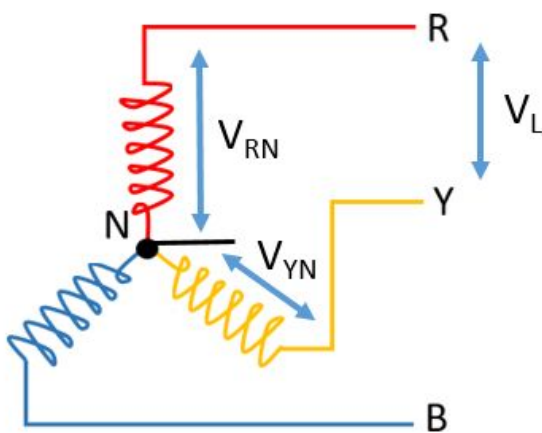

Consider phases R & Y,

$$V_{RN} = V_{ph} \angle 0 = V_{ph} ,$$

$$V_{YN} = V_{ph} \angle -120 = \frac{-V_{ph}}{2} + j \frac{-\sqrt{3}V_{ph}}{2}$$

$$\begin{aligned} V_L &= V_{RN} - V_{YN} \\ &= \frac{3V_{ph}}{2} + j \frac{-\sqrt{3}V_{ph}}{2} \end{aligned}$$

$$\therefore |V_L| = \sqrt{3} |V_{ph}|$$

Point to note is that, in a delta connection, the line voltage is higher than the phase voltage.

13.5 LINE & PHASE CURRENT

Similar to voltage, current can also be defined in 2 ways in a 3 ϕ circuit. Current flowing through the coil (or the load) is called as the phase current

(I_{ph}) and current flowing through any line is called line current (I_L).

In a star connection, the line current and the phase current are one and the same. But in delta connection, these are two different quantities, whose relation can be derived as follows:

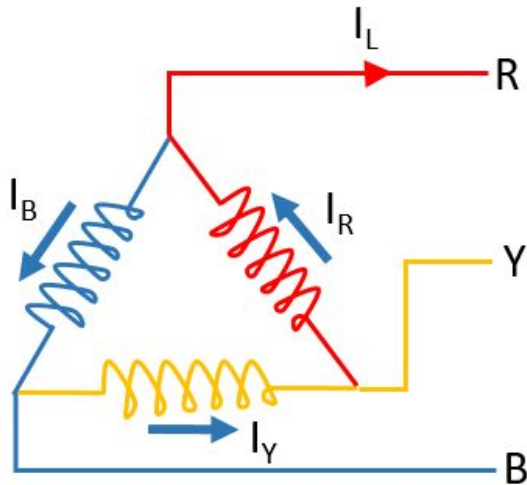

Consider the line R,

$$I_R = I_{ph} \angle 0 = I_{ph} ,$$

$$I_{YN} = I_{ph} \angle -120 = \frac{-I_{ph}}{2} + j \frac{-\sqrt{3}I_{ph}}{2}$$

$$\begin{aligned} I_L &= I_R - I_B \\ &= \frac{3I_{ph}}{2} + j \frac{-\sqrt{3}I_{ph}}{2} \end{aligned}$$

$$\therefore |I_L| = \sqrt{3} |I_{ph}|$$

Thus in a delta connection, the line current is higher than phase current.

13.6 LOAD CONNECTIONS

Loads can also be connected in several ways in a 3 ϕ system as shown below (there are still more connections). The appropriate connection is chosen according to the voltage and the current requirements of the load. Each connection has certain advantages and disadvantages.

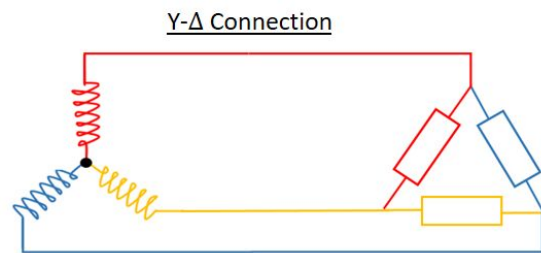
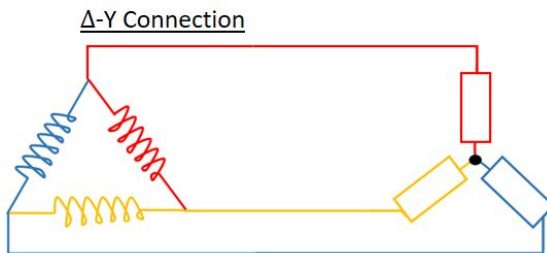
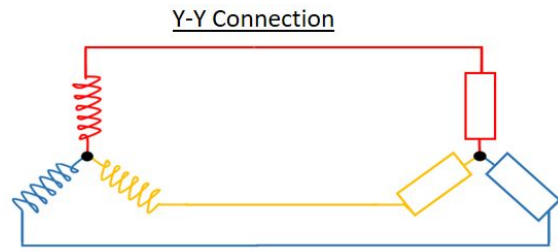
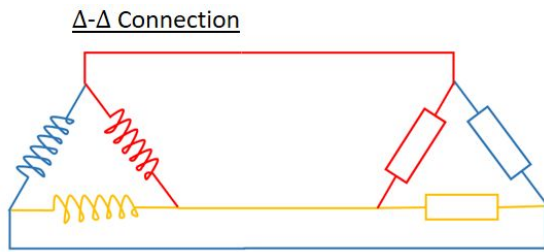

If the impedances or the loads are equally distributed among the 3 phases, such a load is called balanced load.

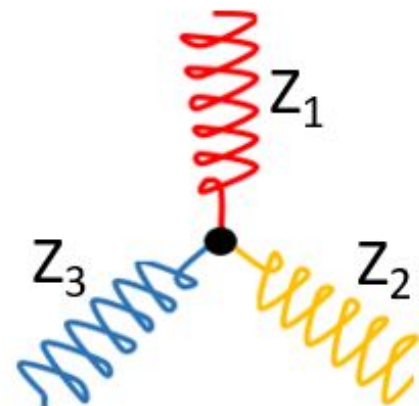
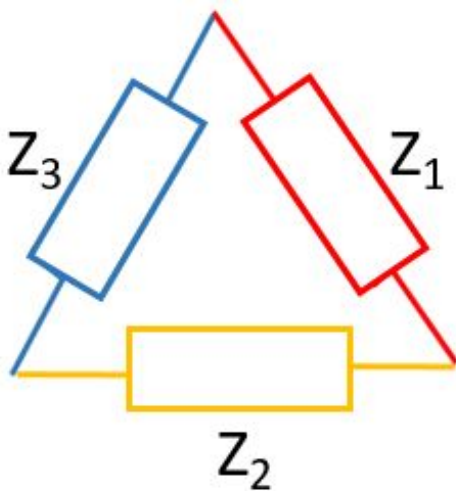

For Balanced Load,
 $Z = Z_1 = Z_2 = Z_3$

13.7 POWER

Three phase power in a circuit is given by:

$$P = \sqrt{3} V_L I_L \cos\phi$$

$$P = 3 V_{ph} I_{ph} \cos\phi$$

These equations are applicable to both star and delta connections.

REFERENCES

1. *Introductory Circuit Analysis* by Robert L. Boylestad
2. *Engineering Circuit Analysis* by Hayt, Kimmerly
3. *Delmar's Standard Textbook of Electricity* by Stephen L. Herman
4. *Basic AC Circuits* by John Clayton Rawlins
5. *Discovering the Laplace Transform in Undergraduate Differential Equations* by Terrance J. Quinn and Sanjay Rai

CONTACT



<https://beyondwhy.me/>



<https://twitter.com/beyondwhy>



beyondwhy@gmail.com