

Operation

Industrial Generator Sets

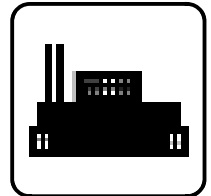

Models:

10-1000 kW

Controller:
Decision-Maker® 3000

Software (Code) Version 1.2 or higher

KOHLER[®]
POWER SYSTEMS



TP-6694 7/11c

Table of Contents

Product Identification Information	2
Safety Precautions and Instructions	5
Introduction	9
Abbreviations	9
List of Related Materials	9
SiteTech™ Software	9
Service Assistance	10
Section 1 Specifications and Features	11
1.1 Introduction	11
1.2 Controller Features	11
1.2.1 Switches and Controls	12
1.2.2 Annunciator Lamps	12
1.2.3 Digital Display	14
1.2.4 Controller Fault Diagnostics	18
1.2.5 Digital Display Circuit Board and Connections	20
1.2.6 Main Logic Circuit Board	20
1.2.7 Terminal Jumper	21
1.2.8 Communication Ports	21
1.2.9 Fuses	21
1.3 Controller Logic Specifications	22
1.3.1 Status Event and Fault Specifications	22
1.3.2 Voltage Regulator and Calibration Specifications	26
1.3.3 Voltage Regulator Adjustments	26
Section 2 Operation	27
2.1 Prestart Checklist	27
2.2 Exercising Generator Set	27
2.3 Controller Operation	27
2.3.1 Starting	28
2.3.2 Stopping (User Stopping and Fault Shutdown)	29
2.3.3 Emergency Stop Switch Resetting	29
2.3.4 System Status Lamps	29
2.3.5 System Fault Warning Lamp with Digital Displays	30
2.3.6 System Fault Shutdown Lamp With Digital Displays	32
2.3.7 Status and Notice Digital Displays	34
2.3.8 Controller Resetting (Following System Shutdown or Warning)	36
2.4 Menu Displays	36
2.5 Monitoring and Programming Setup	38
2.5.1 PC Communications	38
2.5.2 Modbus® Communications	38
2.6 Reviewing Menu Displays	39
2.6.1 Error Messages	39
2.6.2 Overview	40
2.6.3 Engine Metering	40
2.6.4 Generator Metering (and Calibration)	41
2.6.5 GenSet Information	42
2.6.6 GenSet Run Time	42
2.6.7 GenSet System	42
2.6.8 GenSet Calibration	43
2.6.9 Voltage Regulator	44
2.6.10 Digital Inputs	45
2.6.11 Digital Outputs	46
2.6.12 Analog Inputs	47
2.6.13 Event Log	48
2.6.14 Volt Select	48

Table of Contents, continued

Section 3 Scheduled Maintenance	49
3.1 Alternator Service	49
3.2 Engine Service	49
3.3 Service Schedule	50
3.4 Alternator Bearing Service	52
3.4.1 20-300 kW Models	52
3.4.2 300-1000 kW Models with 4M/5M/7M Single-Bearing Alternator	52
3.5 Diesel Fuel Systems	52
3.5.1 Bleeding Air from Fuel System	52
3.6 Gas Fuel Systems	52
3.6.1 Gas Fuel System Concept (Single Fuel)	52
3.6.2 LPG Liquid Withdrawal Fuel System Concept	53
3.6.3 Natural Gas and LPG Conversion	53
3.6.4 Fuel System Changeover Kits (Dual Fuel)	53
3.7 Crankcase Ventilation (CCV) Heater Kit GM78171-KP1	55
3.8 Cooling System	55
3.8.1 Coolant Level Check	55
3.8.2 Cooling System Component Inspection	55
3.8.3 Procedure to Drain Cooling System	56
3.8.4 Procedure to Flush and Clean Cooling System	56
3.8.5 Procedure to Refill Cooling System	56
3.9 Battery	57
3.9.1 Clean Battery	58
3.9.2 Electrolyte Level Inspection	58
3.9.3 Specific Gravity Check	58
3.9.4 Charge Battery	59
3.10 Storage Procedure	59
3.10.1 Lubricating System	59
3.10.2 Cooling System	59
3.10.3 Fuel System	59
3.10.4 Internal Engine Components (Gas-Fueled Engines)	60
3.10.5 Exterior	60
3.10.6 Battery	60
Section 4 General Troubleshooting	61
4.1 General Troubleshooting Chart	62
4.2 Controller Display and Voltage Regulation Troubleshooting Chart	65
Section 5 Voltage Reconnection	67
5.1 Introduction	67
5.2 Voltage Reconnection Procedure (Software version 2.8 or higher)	68
5.3 Voltage Reconnection Procedure (Software version before 2.8)	68
Section 6 Accessories	73
6.1 Accessories and Connections	73
6.1.1 Common Fault/Failure (32A) Relay Kit	73
6.1.2 Float/Equalize Battery Charger Kit with Alarm Option	74
6.1.3 Gas Fuel Valve Kit	74
6.1.4 Input/Output (I/O) Module Board	75
6.1.5 Low Fuel (Level/Pressure) Switch	76
6.1.6 Prime Power Switch Kit	76
6.1.7 Remote Emergency Stop Kit	77
6.1.8 Remote Reset Feature	77
6.1.9 Remote Serial Annunciator	78
6.1.10 Run Relay Kit	80
6.1.11 Shunt-Trip Line Circuit Breaker	80
6.2 Accessory Connections	81
Appendix A Abbreviations	85
Appendix B Programmer-Defined Settings	87
Appendix C Voltage Regulator Definitions and Adjustments	91
Appendix D Alternator Protection	95

Safety Precautions and Instructions

IMPORTANT SAFETY INSTRUCTIONS. Electromechanical equipment, including generator sets, transfer switches, switchgear, and accessories, can cause bodily harm and pose life-threatening danger when improperly installed, operated, or maintained. To prevent accidents be aware of potential dangers and act safely. Read and follow all safety precautions and instructions. **SAVE THESE INSTRUCTIONS.**

This manual has several types of safety precautions and instructions: Danger, Warning, Caution, and Notice.

DANGER

Danger indicates the presence of a hazard that **will cause severe personal injury, death, or substantial property damage.**

WARNING

Warning indicates the presence of a hazard that **can cause severe personal injury, death, or substantial property damage.**

CAUTION

Caution indicates the presence of a hazard that **will or can cause minor personal injury or property damage.**

NOTICE

Notice communicates installation, operation, or maintenance information that is safety related but not hazard related.

Safety decals affixed to the equipment in prominent places alert the operator or service technician to potential hazards and explain how to act safely. The decals are shown throughout this publication to improve operator recognition. Replace missing or damaged decals.

Accidental Starting

WARNING

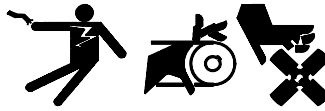

**Accidental starting.
Can cause severe injury or death.**

Disconnect the battery cables before working on the generator set. Remove the negative (-) lead first when disconnecting the battery. Reconnect the negative (-) lead last when reconnecting the battery.

Disabling the generator set. Accidental starting can cause severe injury or death. Before working on the generator set or equipment connected to the set, disable the generator set as follows: (1) Press the generator set off/reset button to shut down the generator set. (2) Disconnect the power to the battery charger, if equipped. (3) Remove the battery cables, negative (-) lead first. Reconnect the negative (-) lead last when reconnecting the battery. Follow these precautions to prevent the starting of the generator set by the remote start/stop switch.

Battery

WARNING



**Sulfuric acid in batteries.
Can cause severe injury or death.**

Wear protective goggles and clothing. Battery acid may cause blindness and burn skin.

WARNING



**Explosion.
Can cause severe injury or death.
Relays in the battery charger
cause arcs or sparks.**

Locate the battery in a well-ventilated area. Isolate the battery charger from explosive fumes.

Battery electrolyte is a diluted sulfuric acid. Battery acid can cause severe injury or death. Battery acid can cause blindness and burn skin. Always wear splashproof safety goggles, rubber gloves, and boots when servicing the battery. Do not open a sealed battery or mutilate the battery case. If battery acid splashes in the eyes or on the skin, immediately flush the affected area for 15 minutes with large quantities of clean water. Seek immediate medical aid in the case of eye contact. Never add acid to a battery after placing the battery in service, as this may result in hazardous spattering of battery acid.

Battery acid cleanup. Battery acid can cause severe injury or death. Battery acid is electrically conductive and corrosive. Add 500 g (1 lb.) of bicarbonate of soda (baking soda) to a container with 4 L (1 gal.) of water and mix the neutralizing solution. Pour the neutralizing solution on the spilled battery acid and continue to add the neutralizing solution to the spilled battery acid until all evidence of a chemical reaction (foaming) has ceased. Flush the resulting liquid with water and dry the area.

Battery gases. Explosion can cause severe injury or death. Battery gases can cause an explosion. Do not smoke or permit flames or sparks to occur near a battery at any time, particularly when it is charging. Do not dispose of a battery in a fire. To prevent burns and sparks that could cause an explosion, avoid touching the battery terminals with tools or other metal objects. Remove all jewelry before servicing the equipment. Discharge static electricity from your body before touching batteries by first touching a grounded metal surface away from the battery. To avoid sparks, do not disturb the battery charger connections while the battery is charging. Always turn the battery charger off before disconnecting the battery connections. Ventilate the compartments containing batteries to prevent accumulation of explosive gases.

Battery short circuits. Explosion can cause severe injury or death. Short circuits can cause bodily injury and/or equipment damage. Disconnect the battery before generator set installation or maintenance. Remove all jewelry before servicing the equipment. Use tools with insulated handles. Remove the negative (-) lead first when disconnecting the battery. Reconnect the negative (-) lead last when reconnecting the battery. Never connect the negative (-) battery cable to the positive (+) connection terminal of the starter solenoid. Do not test the battery condition by shorting the terminals together.

Engine Backfire/Flash Fire

⚠ WARNING

Fire. Can cause severe injury or death. Do not smoke or permit flames or sparks near fuels or the fuel system.

Servicing the fuel system. A flash fire can cause severe injury or death. Do not smoke or permit flames or sparks near the carburetor, fuel line, fuel filter, fuel pump, or other potential sources of spilled fuels or fuel vapors. Catch fuels in an approved container when removing the fuel line or carburetor.

Servicing the air cleaner. A sudden backfire can cause severe injury or death. Do not operate the generator set with the air cleaner removed.

Combustible materials. A fire can cause severe injury or death. Generator set engine fuels and fuel vapors are flammable and explosive. Handle these materials carefully to minimize the risk of fire or explosion. Equip the compartment or nearby area with a fully charged fire extinguisher. Select a fire extinguisher rated ABC or BC for electrical fires or as recommended by the local fire code or an authorized agency. Train all personnel on fire extinguisher operation and fire prevention procedures.

Exhaust System

⚠ WARNING

Carbon monoxide. Can cause severe nausea, fainting, or death. The exhaust system must be leakproof and routinely inspected.

Generator set operation. Carbon monoxide can cause severe nausea, fainting, or death. Carbon monoxide is an odorless, colorless, tasteless, nonirritating gas that can cause death if inhaled for even a short time. Avoid breathing exhaust fumes when working on or near the generator set. Never operate the generator set inside a building unless the exhaust gas is piped safely outside. Never operate the generator set where exhaust gas could accumulate and seep back inside a potentially occupied building.

Carbon monoxide symptoms. Carbon monoxide can cause severe nausea, fainting, or death. Carbon monoxide is a poisonous gas present in exhaust gases. Carbon monoxide is an odorless, colorless, tasteless, nonirritating gas that can cause death if inhaled for even a short time. Carbon monoxide poisoning symptoms include but are not limited to the following:

- Light-headedness, dizziness
- Physical fatigue, weakness in joints and muscles
- Sleepiness, mental fatigue, inability to concentrate or speak clearly, blurred vision
- Stomachache, vomiting, nausea

If experiencing any of these symptoms and carbon monoxide poisoning is possible, seek fresh air immediately and remain active. Do not sit, lie down, or fall asleep. Alert others to the possibility of carbon monoxide poisoning. Seek medical attention if the condition of affected persons does not improve within minutes of breathing fresh air.

Fuel System

⚠ WARNING



Explosive fuel vapors.
Can cause severe injury or death.

Use extreme care when handling, storing, and using fuels.

The fuel system. Explosive fuel vapors can cause severe injury or death. Vaporized fuels are highly explosive. Use extreme care when handling and storing fuels. Store fuels in a well-ventilated area away from spark-producing equipment and out of the reach of children. Never add fuel to the tank while the engine is running because spilled fuel may ignite on contact with hot parts or from sparks. Do not smoke or permit flames or sparks to occur near sources of spilled fuel or fuel vapors. Keep the fuel lines and connections tight and in good condition. Do not replace flexible fuel lines with rigid lines. Use flexible sections to avoid fuel line breakage caused by vibration. Do not operate the generator set in the presence of fuel leaks, fuel accumulation, or sparks. Repair fuel systems before resuming generator set operation.

Explosive fuel vapors can cause severe injury or death. Take additional precautions when using the following fuels:

Propane (LP)—Adequate ventilation is mandatory. Because propane is heavier than air, install propane gas detectors low in a room. Inspect the detectors per the manufacturer’s instructions.

Natural Gas—Adequate ventilation is mandatory. Because natural gas rises, install natural gas detectors high in a room. Inspect the detectors per the manufacturer’s instructions.

Fuel tanks. Explosive fuel vapors can cause severe injury or death. Gasoline and other volatile fuels stored in day tanks or subbase fuel tanks can cause an explosion. Store only diesel fuel in tanks.

Draining the fuel system. Explosive fuel vapors can cause severe injury or death. Spilled fuel can cause an explosion. Use a container to catch fuel when draining the fuel system. Wipe up spilled fuel after draining the system.

Gas fuel leaks. Explosive fuel vapors can cause severe injury or death. Fuel leakage can cause an explosion. Check the LP vapor gas or natural gas fuel system for leakage by using a soap and water solution with the fuel system test pressurized to 6–8 ounces per square inch (10–14 inches water column). Do not use a soap solution containing either ammonia or chlorine because both prevent bubble formation. A successful test depends on the ability of the solution to bubble.

LP liquid withdrawal fuel leaks. Explosive fuel vapors can cause severe injury or death. Fuel leakage can cause an explosion. Check the LP liquid withdrawal gas fuel system for leakage by using a soap and water solution with the fuel system test pressurized to at least 90 psi (621 kPa). Do not use a soap solution containing either ammonia or chlorine because both prevent bubble formation. A successful test depends on the ability of the solution to bubble.

Hazardous Noise

CAUTION



Hazardous noise. Can cause hearing loss.

Never operate the generator set without a muffler or with a faulty exhaust system.

Engine noise. Hazardous noise can cause hearing loss. Generator sets not equipped with sound enclosures can produce noise levels greater than 105 dBA. Prolonged exposure to noise levels greater than 85 dBA can cause permanent hearing loss. Wear hearing protection when near an operating generator set.

Hazardous Voltage/ Moving Parts

DANGER



Hazardous voltage. Will cause severe injury or death.

Disconnect all power sources before opening the enclosure.

WARNING



Hazardous voltage. Moving parts. Can cause severe injury or death.

Operate the generator set only when all guards and electrical enclosures are in place.

WARNING



Hazardous voltage. Backfeed to the utility system can cause property damage, severe injury, or death.

If the generator set is used for standby power, install an automatic transfer switch to prevent inadvertent interconnection of standby and normal sources of supply.

Grounding electrical equipment. Hazardous voltage can cause severe injury or death. Electrocutation is possible whenever electricity is present. Ensure you comply with all applicable codes and standards. Electrically ground the generator set, transfer switch, and related equipment and electrical circuits. Turn off the main circuit breakers of all power sources before servicing the equipment. Never contact electrical leads or appliances when standing in water or on wet ground because these conditions increase the risk of electrocution.

High voltage test. Hazardous voltage can cause severe injury or death. Follow the instructions of the test equipment manufacturer when performing high-voltage tests on the rotor or stator. An improper test procedure can damage equipment or lead to generator set failure.

Installing the battery charger. Hazardous voltage can cause severe injury or death. An ungrounded battery charger may cause electrical shock. Connect the battery charger enclosure to the ground of a permanent wiring system. As an alternative, install an equipment grounding conductor with circuit conductors and connect it to the equipment grounding terminal or the lead on the battery charger. Install the battery charger as prescribed in the equipment manual. Install the battery charger in compliance with local codes and ordinances.

Connecting the battery and the battery charger. Hazardous voltage can cause severe injury or death. Reconnect the battery correctly, positive to positive and negative to negative, to avoid electrical shock and damage to the battery charger and battery(ies). Have a qualified electrician install the battery(ies).

Short circuits. Hazardous voltage/current can cause severe injury or death. Short circuits can cause bodily injury and/or equipment damage. Do not contact electrical connections with tools or jewelry while making adjustments or repairs. Remove all jewelry before servicing the equipment.

Engine block heater. Hazardous voltage can cause severe injury or death. The engine block heater can cause electrical shock. Remove the engine block heater plug from the electrical outlet before working on the block heater electrical connections.

Electrical backfeed to the utility. Hazardous backfeed voltage can cause severe injury or death. Install a transfer switch in standby power installations to prevent the connection of standby and other sources of power. Electrical backfeed into a utility electrical system can cause severe injury or death to utility personnel working on power lines.

Testing live electrical circuits. Hazardous voltage or current can cause severe injury or death. Have trained and qualified personnel take diagnostic measurements of live circuits. Use adequately rated test equipment with electrically insulated probes and follow the instructions of the test equipment manufacturer when performing voltage tests. Observe the following precautions when performing voltage tests: (1) Remove all jewelry. (2) Stand on a dry, approved electrically insulated mat. (3) Do not touch the enclosure or components inside the enclosure. (4) Be prepared for the system to operate automatically. (600 volts and under)

⚠ WARNING



Airborne particles. Can cause severe injury or blindness.

Wear protective goggles and clothing when using power tools, hand tools, or compressed air.

Servicing the generator set when it is operating. Exposed moving parts can cause severe injury or death. Keep hands, feet, hair, clothing, and test leads away from the belts and pulleys when the generator set is running. Replace guards, screens, and covers before operating the generator set.

Heavy Equipment

⚠ WARNING



Unbalanced weight. Improper lifting can cause severe injury or death and equipment damage.

Do not use lifting eyes. Lift the generator set using lifting bars inserted through the lifting holes on the skid.

Hot Parts

⚠ WARNING



Hot coolant and steam. Can cause severe injury or death.

Before removing the pressure cap, stop the generator set and allow it to cool. Then loosen the pressure cap to relieve pressure.

⚠ WARNING



Hot engine and exhaust system. Can cause severe injury or death.

Do not work on the generator set until it cools.

Servicing the alternator. Hot parts can cause severe injury or death. Avoid touching the alternator field or exciter armature. When shorted, the alternator field and exciter armature become hot enough to cause severe burns.

Servicing the exhaust system. Hot parts can cause severe injury or death. Do not touch hot engine parts. The engine and exhaust system components become extremely hot during operation.

Notice

NOTICE

This generator set has been rewired from its nameplate voltage to



246242

NOTICE

Voltage reconnection. Affix a notice to the generator set after reconnecting the set to a voltage different from the voltage on the nameplate. Order voltage reconnection decal 246242 from an authorized service distributor/dealer.

NOTICE

Canadian installations only. For standby service connect the output of the generator set to a suitably rated transfer switch in accordance with Canadian Electrical Code, Part 1.

This manual provides operation instructions for 10 kW and larger generator sets equipped with the following controller:

- Decision-Maker® 3000, Software (Code) Version 1.2 or higher

Version 1.2 refers to the controller application software. To determine the generator set controller software version, go to the Overview menu.

Version 3.0.25 or higher contains the voltage selection feature and remote communication.

Wiring diagram manuals are available separately. Refer to the engine operation manual for generator set engine scheduled maintenance information.

Information in this publication represents data available at the time of print. Kohler Co. reserves the right to change this publication and the products represented without notice and without any obligation or liability whatsoever.

Read this manual and carefully follow all procedures and safety precautions to ensure proper equipment operation and to avoid bodily injury. Read and follow the Safety Precautions and Instructions section at the beginning of this manual. Keep this manual with the equipment for future reference.

The equipment service requirements are very important to safe and efficient operation. Inspect the parts often and perform required service at the prescribed intervals. Maintenance work must be performed by appropriately skilled and suitably trained maintenance personnel familiar with generator set operation and service.

Abbreviations

This publication makes use of numerous abbreviations. Typically, the word(s) are spelled out along with the abbreviation in parentheses when shown for the first time in a section. Appendix A, Abbreviations, also includes many abbreviation definitions.

List of Related Materials

Separate literature contains communication and software information not provided in this manual. Figure 1 lists the available literature part numbers.

Literature Description	Literature Part No.
Controller Spec Sheet	G6-100
Generator Set/Controller Wiring Diagram Manual	Multiple Part Numbers Contact your Distributor/Dealer
Modbus® Communications Protocol Operation Manual	TP-6113
Service Parts Decision-Maker® 3000 Controller	TP-6781
SiteTech™ Software Operation Manual	TP-6701
Remote Serial Annunciator II (RSA II)	TT-1485
Converters, Connections, and Controller Setup for Network Communication	TT-1405

Figure 1 Related Literature

Several engine manufacturers provide engines with electronic controls. These electronic controls indicate engine fault codes in addition to the generator set controller. The engine operation and service literature provide information for identifying engine fault codes. For the latest literature part numbers, see the respective Parts Catalog.

SiteTech™ Software

Several instances in this manual make reference to SiteTech™ software which is required for programming the Decision-Maker® 3000 controller. SiteTech™ software is also needed for updating the controller application code. Contact your local distributor/dealer for assistance.

For professional advice on generator set power requirements and conscientious service, please contact your nearest Kohler distributor or dealer.

- Consult the Yellow Pages under the heading Generators—Electric.
- Visit the Kohler Power Systems website at KohlerPower.com.
- Look at the labels and stickers on your Kohler product or review the appropriate literature or documents included with the product.
- Call toll free in the US and Canada 1-800-544-2444.
- Outside the US and Canada, call the nearest regional office.

Headquarters Europe, Middle East, Africa (EMEA)

Kohler Power Systems
3 rue de Brennus
93200 Saint Denis
France
Phone: (33) 1 49 178300
Fax: (33) 1 49 178301

Asia Pacific

Power Systems Asia Pacific Regional Office
Singapore, Republic of Singapore
Phone: (65) 6264-6422
Fax: (65) 6264-6455

China

North China Regional Office, Beijing
Phone: (86) 10 6518 7950
(86) 10 6518 7951
(86) 10 6518 7952
Fax: (86) 10 6518 7955

East China Regional Office, Shanghai
Phone: (86) 21 6288 0500
Fax: (86) 21 6288 0550

India, Bangladesh, Sri Lanka

India Regional Office
Bangalore, India
Phone: (91) 80 3366208
(91) 80 3366231
Fax: (91) 80 3315972

Japan, Korea

North Asia Regional Office
Tokyo, Japan
Phone: (813) 3440-4515
Fax: (813) 3440-2727

Latin America

Latin America Regional Office
Lakeland, Florida, USA
Phone: (863) 619-7568
Fax: (863) 701-7131

Section 1 Specifications and Features

1.1 Introduction

The spec sheets for each generator set provide model-specific generator and engine information. The controller spec sheet provides specifications for this controller. Refer to the respective spec sheet for data not supplied in this manual. Refer to the generator set service manual, installation manual, engine operation manual, and engine service manual for additional specifications.

1.2 Controller Features

The controller features include the annunciator lamp, digital display and pushbutton/rotary selector dial, switches and controls, and fuses and terminal strip. The following paragraphs detail the features by general topics.

See Figure 1-1 for an illustration of the controller front panel.

The controller features, accessories, and menu displays depend upon the engine electronic control module (ECM) setup and features. Controller features apply to generator set models with ECM and non-ECM engines unless otherwise noted.

Note: Press the pushbutton/rotary selector dial to turn on the controller lights and display. The light and display turn off 60 minutes after the last entry when in the AUTO mode.

Note: After about 5 minutes of no user input (pushbutton/rotary selector dial or buttons), the menu is reset to the top of the main menus and auto-paging activates for the Overview submenus.

Note: Measurements display in metric or English units. Use the Generator Set System menu to change the measurement display.

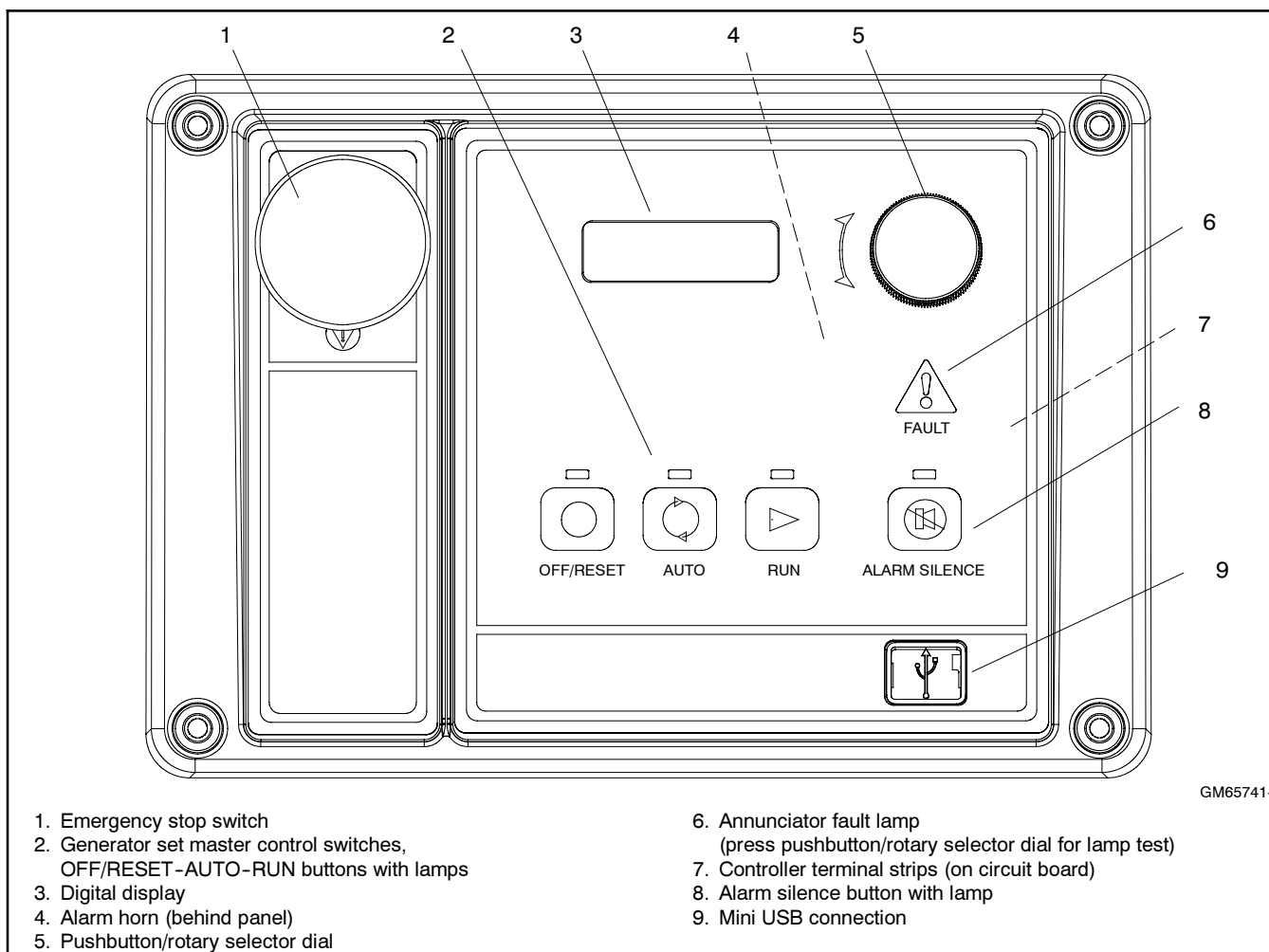

Figure 1-1 Decision-Maker® 3000 Controller with Digital Display and Pushbutton/Rotary Selector Dial

1.2.1 Switches and Controls

Note: **US/Metric Display** is selectable in Section 1.2.3—Digital Display—Generator Set System Menu.

Alarm Horn. The alarm horn alerts the operator or other attendants that a shutdown or warning condition exists.

Alarm (Horn) Silence. The alarm silence switch silences the alarm horn at the operator’s discretion. Press the master control switch AUTO button *before* pressing the alarm silence button. The alarm horn cannot be silenced unless the master control switch AUTO button is pressed.

Note: Additional alarm silencing options are shown in Section 1.2.3—Digital Display—Generator Set System Menu.

Restore alarm horn switches at all locations including those on remote annunciator kits after correcting the fault shutdown to avoid reactivating the alarm horn. See Section 2—Operation, 2.3.8 Controller Resetting for resetting the controller.

Emergency Stop. The operator-activated pushbutton immediately shuts down the generator set in emergency situations. Reset the emergency stop switch after shutdown by pulling the emergency stop switch outward. *Use the emergency stop switch for emergency shutdowns only.* Use the master control switch OFF/RESET button for normal shutdowns.

Generator Set Master Control Switches (OFF/RESET-AUTO-RUN). These switches reset the controller fault lamps and start/stops the generator set. Additional information in shown in Section 2—Operation.

Lamp Test. Press and hold the Alarm Silence/Lamp Test button to test the controller indicator lamps, alarm horn, and digital display.

Pushbutton/Rotary Selector Dial. This control provides access to the menus for monitoring. Press the selector dial to activate the digital display and to select choices shown on the display. Rotate the dial to navigate through the menus.

The pushbutton/rotary selector dial has several features and functions:

- Momentarily press the dial to activate the digital display if dark.
- Rotate the dial to navigate through the main menus—turn clockwise to go forward (down) and counterclockwise to go back (up). The menus do not wrap to the beginning.

- Press the dial at a given main menu to access the submenus within the selected main menu.
- When in the submenu, rotate the dial to navigate through the submenu—clockwise to go forward (down) and counterclockwise to go back (up). The menus do not wrap to the beginning.
- Momentarily press the dial when in the submenu to make a user selection choice (if available) or to go back to the respective main menu.
- Press the dial for at least 3 seconds to return to the top of the main menus (Overview) regardless if you are in the main menus or submenus.
- After about 5 minutes of no user input (pushbutton/rotary selector dial or buttons), the menu resets to the top of the main menus and auto-paging activates for the Overview submenus.

1.2.2 Annunciator Lamps

The controller has a single annunciator fault lamp providing visual generator set status. In addition, each button has a corresponding lamp. See Figure 1-2.

Lamp/Button	Lamp Color
Alarm (Fault) Lamp	Yellow (Warning) or Red (Shutdown)
Off/Reset Button	Red
Auto Button	Green (System Ready)
Run Button	Yellow
Alarm Silence Button	Yellow

Figure 1-2 Annunciator Lamps

System Status Lamps (Master Control Switches)

The green lamp illuminates on the master control switch AUTO (automatic start) button indicating the system senses no faults and the unit is ready to start by remote command.

The red lamp illuminates on the master control switch OFF/RESET button indicating the generator set is stopped.

The yellow lamp illuminates on the master control switch RUN button indicating the generator set is cranking or running from a local command.

Only one of the three master control switch lamps will illuminate at any given time.

Alarm Silence Lamp. Red lamp illuminates indicating the alarm horn was silenced.

(System) Fault Lamp. Yellow lamp illuminates indicating a warning condition or red lamp illuminates indicating a shutdown condition. See System Warning Fault Lamp and System Shutdown Fault Lamp following for system fault conditions.

System Warning Fault Lamp. Yellow lamp identifies an existing fault condition that does not shut down the generator set. A continuing system warning fault condition may cause a system shutdown. Correct all system warnings as soon as practical.

See Section 2.3.5, System Fault Warning Lamp with Digital Displays, for definitions of the items listed. The following conditions cause a system warning:

- AC sensing loss
- Auxiliary input (analog or digital)
- Battery charger fault *
- Common fault
- Critical high fuel level (diesel-powered models only) *
- ECM diagnostics (multiple engine inputs)
- Default parameters loaded
- Fuel tank leak (diesel-powered models only) *
- Ground fault *
- High battery voltage
- High coolant temperature
- High fuel level (diesel-powered models only) *
- Input/output communication loss
- Low battery voltage
- Low coolant temperature
- Low cranking voltage
- Low engine oil level *
- Low fuel (level for diesel-powered models) *
- Low fuel (pressure for gas-powered models) *
- Low oil pressure
- Not-in-auto (master control switch)
- Speed sensor fault

* Requires optional input sensors.

System Shutdown Fault Lamp. Red lamp indicates that the generator set has shut down because of a fault condition. The unit will not start without resetting the controller, see Section 2.3.8, Controller Resetting procedure.

See Section 2.3.6, System Fault Shutdown Lamp with Digital Displays, for definitions of the items listed. The following conditions cause a system shutdown:

- AC sensing loss
- Alternator protection
- Auxiliary input (analog or digital)
- Common fault
- ECM communications loss
- ECM diagnostics (multiple engine inputs)
- ECM faults (model mismatch and address conflict)
- Emergency stop
- Engine over speed
- Engine under speed
- File system error (controller firmware fault)
- Fuel tank leak (diesel-powered models only) *
- High coolant temperature
- Internal failure
- kW overload
- Locked rotor (failed to crank)
- Low coolant level *
- Low engine oil level *
- Low fuel level (diesel-powered models only) *
- Low oil pressure
- Metering communication loss
- No coolant temperature signal
- No oil pressure signal
- Overcrank
- Overfrequency
- Overvoltage (each phase)
- Underfrequency
- Undervoltage (each phase)
- (Voltage) regulator communication loss

* Requires optional input sensors.

1.2.3 Digital Display

Press the pushbutton/rotary selector dial to turn on the controller lamps and display. The lamps and display turn off 60 minutes after the last entry.

The generator set must be running for some displays to indicate values. If the generator set is not running some values will display zero or N/A (not available).

The 12-character, 2-line backlit heated display provides generator set and engine data, system status, and fault information. See Figure 1-1. The digital display shows abbreviations in some instances, refer to 1.3.1 Status Event and Fault Specifications for the abbreviations and their full descriptions.

Note: US/Metric Unit Display is selectable in Generator Set System.

Note: After about 5 minutes of no user input (pushbutton/rotary selector dial or buttons), the menu resets to the top of the main menus and auto-paging activates for the Overview submenus.

The main menus are listed below. Within each main menu are multiple submenus with descriptions following.

- Overview
- Engine Metering
- Generator Metering
- GenSet Information
- GenSet Run Time
- GenSet System
- GenSet Calibration (Before Version 3.0.25)
- Voltage Regulation
- Digital Inputs
- Digital Outputs
- Analog Inputs
- Event Log
- Volt Select (Version 2.8.22 or higher)

Overview Menu

When a new shutdown or warning fault occurs, the auto-paging display feature activates.

Active **Shutdowns** display if any are present. This alerts the user to single or multiple shutdown fault conditions. See 1.2.2—Annunciator Lamps—System Shutdown Fault Lamp for a list of possible shutdown faults.

Active **Warnings** display if any are present. This alerts the user to single or multiple warning fault conditions.

See 1.2.2—Annunciator Lamps—System Warning Fault Lamp for a list of possible warning faults.

Generator Set State displays the generator set status:

- Off
- Standby
- Running
- Cooldown
- Stopping

Average Volts Line-to-Line value displays. For three-phase configurations the average line-to-line voltage of L1, L2, and L3 is displayed. Single-phase configurations show the L1-L2 voltage.

Frequency (Hz) value displays for the output AC voltage.

Current value displays as the average for three-phase configurations or the current value for L1-L2 with single-phase configurations.

Average kW displays. For three-phase configurations the average line-to-line kilowatts of L1, L2, and L3 is displayed. Single-phase configurations show the L1-L2 kilowatts.

Coolant Temperature displays for the engine coolant temperature.

Oil Pressure displays the engine oil pressure.

Fuel Level % displays the fuel tank level for diesel-powered models.

Fuel Pressure displays the fuel line pressure at the generator set inlet for gas-powered models.

Battery displays the DC voltage of the engine starting battery(ies).

Engine Run Time displays the total run time hours.

Software Version displays in the Overview menu. Use the version number to determine if an upgrade is needed and/or when troubleshooting the controller.

Engine Metering Menu

Engine Speed (Tachometer) displays the engine speed in RPM.

Oil Pressure displays the engine oil pressure. This value also shows in the Overview Menu.

Coolant Temperature displays the engine coolant temperature. This value also shows in the Overview Menu.

Fuel Level % displays the fuel tank level for diesel-powered models. This value also shows in the Overview Menu.

Battery displays the DC voltage of the engine starting battery(ies). This value also shows in the Overview Menu.

Fuel Pressure displays the fuel line pressure at the generator set inlet for gas-powered models. This value also shows in the Overview Menu.

Generator Metering Menu

Total Power kVA and kW displays alternator output as actual output values.

Rated Power displays alternator output as a percentage of the entered data value.

Volts displays the alternator output AC voltages. The display shows all line-to-line and line-to-neutral voltage combinations for three-phase or single-phase configurations.

Current displays the alternator output AC amps. The display shows each line (L1-L2-L3) of three-phase models or L1-L2 current for single-phase models.

Frequency (Hz) value displays for the output AC voltage. This value also shows in the Overview Menu.

Reset Calibration providing the means to reset the configuration values is available in this menu in controller firmware version 3.0.25 or higher.

The calibration values are reviewable at all times and provide the calibration of the voltage and current sensing logic. Changing the system voltage or replacing the circuit board requires a calibration adjustment.

To enable calibration, start the generator set and select the *Volts L1-L2* display. Then push and hold the pushbutton/rotary selector dial until the *Calibration Enabled* popup appears. Calibration of each display is now available. The display will show the following values for three-phase generator sets. Single-phase generator sets will only display items marked (*).

- Volts L1-L2 *
- Volts L2-L3
- Volts L3-L1
- Volts L1-N *
- Volts L2-N *
- Volts L3-N
- Current L1 *
- Current L2 *
- Current L3

The user can change individual values or can select *Reset Calib?*-Yes to reset all values. The *Reset Calib?* display will only show if calibration is enabled. Refer to the requirements shown with Generator Set Calibration in 2.3.7 Status and Notice Digital Displays.

To disable calibration, Rotate the pushbutton/rotary selector dial until the *<-Return* popup appears. Momentarily press the pushbutton/rotary selector dial. Stop the generator set if not already done.

Generator Set Information Menu

GenSet M/N displays the generator set model number.

GenSet S/N displays the generator set serial number.

Controller S/N displays the controller serial number.

Generator Set Run Time Menu

Engine Run Time displays the total run time hours. This value also shows in the Overview Menu.

Engine Loaded displays the total loaded hours.

Engine Starts displays the total number of generator set startup events.

Total Energy displays the total kW hours.

Generator Set System Menu

The values in this menus are user-entered for the generator set configuration and are NOT measured values of the generator set.

Changes to the Generator Set System menu require the use of SiteTech™ software except for Measure System and Contrast selections.

System Frequency displays the programmer-entered L1-L2-L3 output voltage frequency for three-phase or the L1-L2 output voltage frequency for single-phase.

System Phase displays the programmer-entered configuration as Single Phase, Single Phase Dog Leg, Three Phase Wye, or Three Phase Delta.

System Voltage displays the programmer-entered L1-L2-L3 output voltage for three-phase or the L1-L2 output voltage for single-phase.

Power Rating displays the programmer entered kW value for the generator set.

Amp Rating displays the programmer entered current value for the generator set.

Power Type displays the programmer entered generator set application configuration as Standby or Prime.

Battery Voltage displays the engine electrical system 12 or 24 volts.

Measurement System displays the user selected unit of measure as Metric or English.

Contrast displays user selected resolution values to improve digital display clarity.

Alarm Silence displays the programmer selected alarm silence method Always or Auto Only using SiteTech™ software. The Always selection activates the alarm horn in any of the OFF/RESET-AUTO-RUN modes. The Auto Only selection activates the alarm horn only when in the Auto mode.

Note: Press the Alarm Silence/Lamp Test button to silence the alarm horn.

Generator Set (Reset) Calibration Menu

This menu is only available in controller firmware versions before 3.0.25. Go to Generator Metering Menu—Reset Calibration with controller firmware version 3.0.25 and higher.

The calibration values are reviewable at all times and provide the calibration of the voltage and current sensing logic. Changing the system voltage or replacing the circuit board requires a calibration adjustment. In order to review the values when the generator set is NOT running, enter Yes when the *Enter Calib?* is displayed. The user can review the values but attempting to change the values will cause a *Cannot calibrate* error message.

If the unit is NOT running and No is entered when the *Enter Calib?* is shown, the display returns to the Generator Set Calibration main menu and entry to the Generator Set Calibration menu is denied.

If the unit is running and Yes is entered when the *Enter Calib?* is shown, the display will show the following values for three-phase generator sets. Single-phase generator sets will only display items marked (*).

- Volts L1-L2 *
- Volts L2-L3
- Volts L3-L1
- Volts L1-N *
- Volts L2-N *
- Volts L3-N
- Current L1 *
- Current L2 *
- Current L3

The user can change individual values or can enter Yes when *Reset all Calib?* is displayed. At the end of the Generator Set Calibration menu, *Exit calibration* is shown. Press the pushbutton/rotary selector dial to exit this menu. Refer to the requirements shown with Generator Set Calibration in 2.3.7 Status and Notice Digital Displays.

Voltage Regulator Menu

Controller firmware before 3.0.25.

The voltage regulator value is reviewable at all times. In order to review the value when the generator set is NOT running, enter Yes when the *Enter volt reg?* is displayed. The user can review the value but attempting to change the value will cause a *Cannot edit when stopped* error message.

If the unit is NOT running and No is entered when the *Enter volt reg?* is shown, the display returns to the Voltage Regulator main menu and entry to the Voltage Regulator menu is denied.

If the unit is running and Yes is entered when the *Enter volt reg?* is shown, the display will show the value.

The user can change the value at this time. At the end of the Voltage Regulator menu, *Exit voltage reg* is shown--press the pushbutton/rotary selector dial to exit this menu.

Controller firmware 3.0.25 and higher.

The voltage regulator value is reviewable at all times and provides the ability to fine adjust voltage. Changing the system voltage or replacing the circuit board typically requires a voltage adjustment.

To enable calibration, start the generator set and select the *VR Volt Adj* display. Then push and hold the pushbutton/rotary selector dial until the *Editing Enabled* popup appears. Editing of the voltage adjustment is now available.

The user can change the individual value or can select *Reset VR? - Yes* to reset to the default value. The *Reset VR Settings* display will only show if editing is enabled.

To disable calibration, Rotate the pushbutton/rotary selector dial until the *<-Return* popup appears. Momentarily press the pushbutton/rotary selector dial. Stop the generator set if not already done.

Digital Inputs Menu

This menu allows the user to review the settings. There are up to three digital inputs that are programmer selectable if not reserved by factory options.

There is an optional 2 input/5 output (I/O) module board available that can provide two additional digital (or analog) inputs.

The displays for digital inputs appear as shown below with Values true or false. Items shown in the digital display as True are active.

- DIn A1 (digital input A1) standard
- DIn A2 (digital input A2) standard
- DIn A3 (digital input A3) standard
- DIn B1 (digital input B1) with I/O module board
- DIn B2 (digital input B2) with I/O module board

Changes to the Digital Inputs menu requires the use of SiteTech™ software. The digital input can either open or close the circuit to activate.

Digital Outputs Menu

This menu allows the user to review the settings. There is one digital output standard with the controller that is programmer selectable. The one SPDT switch has 2 amp. contacts at 32 VDC or 0.5 amp. contacts at 120 VAC max.

There is an optional 2 input/5 output (I/O) module board available that can provide five digital outputs. The standard digital output on the controller is used to drive the optional I/O Module board and becomes factory reserved and no longer available as programmer selectable.

The displays for digital outputs appear as shown in the following list with Values as True or False. Items shown in the digital display as True are active.

- DOut A1 (digital output A1) standard
- DOut B1 (digital output B1) with I/O module board
- DOut B2 (digital output B2) with I/O module board
- DOut B3 (digital output B3) with I/O module board
- DOut B4 (digital output B4) with I/O module board
- DOut B5 (digital output B5) with I/O module board

Changes to the Digital Outputs menu requires the use of SiteTech™ software. The digital output can either open or close the circuit to activate.

Analog Inputs Menu

This menu allows the user to review the settings. There is one analog input that is programmer selectable if not reserved by factory options.

There is an optional 2 input/5 output (I/O) module board available that can provide two additional analog (or digital) inputs.

The displays for analog inputs appear as shown below with Values of 0–5 volts.

- AIn A1 (analog input A1) standard (reserved and not user programmable)
- AIn A2 (analog input A2) standard
- AIn B1 (analog input B1) with I/O module board
- AIn B2 (analog input B2) with I/O module board

Changes to the Analog Inputs menu requires the use of SiteTech™ software.

Event Log Menu

This menu allows the user to review up to 1000 entries of system events including shutdown faults, warning faults, and status events. See 1.2.4 Controller Fault Diagnostics for a list of the items that appear on the Event Log.

Volt Select Menu

This menu is only available in controller firmware version 2.8.22 and higher.

Note: The generator set must be stopped before changing the voltage selection.

This menu allows the user to readily change controller voltage settings. The volt select feature is typically used in towable or temporary applications.

Note: The volt select menu requires initial activation by SiteTech™ software. In SiteTech™ software, select True to activate the volt select menu.

Note: The generator set output leads require voltage reconnection if the generator set does not have a voltage selector switch installed.

With the generator set stopped, go to the Volt Select menu. Then push and hold the pushbutton/rotary selector dial until the voltage selection starts to flash. Volt selection is now available. Scroll to the desired voltage and momentarily press the pushbutton/rotary selector dial to confirm the voltage selection.

The displays for *Volt Select* appear as shown in the following list.

- 120/240 V 1 Ph
- 120/208 V 3 Ph
- 139/240 V 3 Ph
- 277/480 V 3 Ph
- 120/240 V 3 Ph

1.2.4 Controller Fault Diagnostics

This table provides descriptions of the system events and their types—warning, shutdown, status, and notice.

Warnings show yellow fault lamp and signal an impending problem. **Shutdowns** show red fault lamp and stop the generator set. **Status** is an event that is not an alert but is part of the event history. **Notice** is an alert

that is NOT part of the event history. System events are available as a **Relay Output** as shown.

Throughout this manual there are examples of the display text. In some cases, the message words and phrases are abbreviated or shortened to accommodate the number of characters in the 12 x 2 digital display. See the following table for a full description of the system event display messages.

System Events Display Message List

Description	Display Message	Warning Function	Shutdown Function	Status/ Notice	Relay Output
Engine Functions					
Critically high fuel level (diesel-powered models only) *	Fuel Level Critically High	X			X
ECM communications loss	ECM Comm Err Shutdwn		X		X
ECM diagnostics (multiple inputs) †	ECM xxxxxx Warning	X			X
ECM diagnostics (multiple inputs) †	ECM xxxxxx Shutdwn		X		X
ECM faults (address conflict)	ECM Addr Err Shutdwn		X		X
ECM faults (model mismatch)	ECM Mismatch Shutdwn		X		X
Engine over speed	Eng Speed High Shutdwn		X‡		X
Engine start aid active	Starting Aid Notice			N	X
Engine under speed	Eng Speed Low Shutdwn		X		X
Fuel tank leak *	Fuel Leak Warning	X			X
Fuel tank leak *	Fuel Leak Shutdwn		X		X
High battery voltage	Battery High Warning	X			X
High coolant temperature	Coolnt Temp High Warning	X			X
High coolant temperature	Coolnt Temp High Shutdwn		X‡		X
High fuel level (diesel-powered models only) *	Fuel Level High Warning	X			X
Low battery voltage	Battery Low Warning	X			X
Low coolant level *	Coolant Lvl Low Shutdwn		X		X
Low coolant temperature	Coolant Temp Low Warning	X			X
Low cranking voltage	Lo Crank Vlt Warning	X			X
Low engine oil level *	Oil Level Low Warning	X			X
Low engine oil level *	Oil Level Low Shutdwn		X		X
Low fuel level (diesel models) *	Fuel Level Low Warning	X			X
Low fuel level (diesel models) *	Fuel Level Low Shutdwn		X		X
Low fuel pressure (gas models) *	Fuel Press Low Warning	X			X
Low oil pressure	Oil Press Low Warning	X			X
Low oil pressure	Oil Press Low Shutdwn		X‡		X
No coolant temperature signal	Temp Sig Loss Shutdwn		X		X
No oil pressure signal	Press Sig Loss Shutdwn		X		X
Overcrank	Over Crank Shutdwn		X‡		X
Speed sensor fault	Spd Sens Flt Warning	X			X
General Functions					
Alarm horn silenced	(Alarm Silence LED only)				X
Alarm silence, auto only (NFPA 110) or always	AlrmSilence: Auto Only or AlrmSilence: Always			S	No
Aux. inputs 0-5 VDC, 1 analog (2 additional inputs available with I/O module option)	Aux Input Warning	X			X
Aux. inputs 0-5 VDC, 1 analog (2 additional inputs available with I/O module option)	Aux Input Shutdwn		X		X
Auxiliary inputs, up to 3 digital (2 additional inputs available with I/O module option)	Aux Input Warning	X			X
Auxiliary inputs, up to 3 digital (2 additional inputs available with I/O module option)	Aux Input Shutdwn		X		X
Backup parameters loaded	Backup Pars Status			S	No
Battery charger fault *	Batt Chg Flt Warning	X			X

Description	Display Message	Warning Function	Shutdown Function	Status/ Notice	Relay Output
Chicago code active *	Auto Locked Notice			N	X
Common fault (includes ‡)	Common Fault Shutdwn		X	N	X
Common warning fault	Common Warng	X		N	X
Default parameters loaded	Default Pars Warning	X			X
Emergency stop	Emerg Stop Shutdwn		X‡		X
Engine cooldown (delay) active	Eng Cooldown Notice			N	X
Engine start delay active	Start Delay Notice			N	X
Engine started	Engine Start Status			S	X
Engine stopped	Engine Stop Status			S	X
EPS supplying load	Emerg Pwr On Notice			N	X
File system error (controller fault)	File Error Shutdwn		X		X
Generator running	Gen Running Notice			N	X
Input/output (module option board) communication loss	OB1 Com Loss	X			X
Internal failure	Intern Error Shutdwn		X		X
Metering communication loss	MeterCommLos Shutdwn		X		X
NFPA 110 alarm active	NFPA Alarm Notice			N	X
Not in auto (master switch)	Not In Auto Warning	X			X
Remote start	Remote Start Status			S	X
System ready	System Ready Status			S	X
System timer failed	Timer Error Notice			N	X
Generator Functions					
AC sensing loss	AC Sens Loss Warning	X			X
AC sensing loss	AC Sens Loss Shutdwn		X		X
Alternator protection	Alt Protect Shutdwn		X		X
Ground fault input *	Ground Fault Warning	X			X
kW overload	Total Power High Shutdwn		X		X
Locked rotor (failed to crank)	Locked Rotor Shutdwn		X		X
Overfrequency	Freq High Shutdwn		X		X
Overvoltage (each phase)	Volts xx-xx High Shutdwn		X		X
Underfrequency	Frequency Low Shutdwn		X		X
Undervoltage (each phase)	Volts xx-xx Low Shutdwn		X		X
(Voltage) regulator communication loss	RegCommLoss Shutdwn		X		X

* Some functions require optional input sensors or are engine ECM dependent on some generator set models.

† ECM inputs are engine manufacturer dependent.

‡ The Common Fault Shutdown includes the items marked X‡ in the Shutdown Function column.

1.2.5 Digital Display Circuit Board and Connections

The digital display circuit board provides:

- The backlit LCD (liquid crystal display) for monitoring the generator set functions and output values
- Master control switches with status lights
- Fault lamp
- Pushbutton/rotary selector dial to navigate the generator set displays
- Alarm horn and alarm silence switch/light
- Mini USB connector for PC setup using SiteTech™ software

See Figure 1-3 for the circuit board connections.

Circuit Board Connections

P9 Connector the 24-pin connector attaches directly to the main logic circuit board.

P10 Connector mini USB for PC upgrades located on the front panel using SiteTech™ software.

P11 Connector is a 20-pin connector (not used).

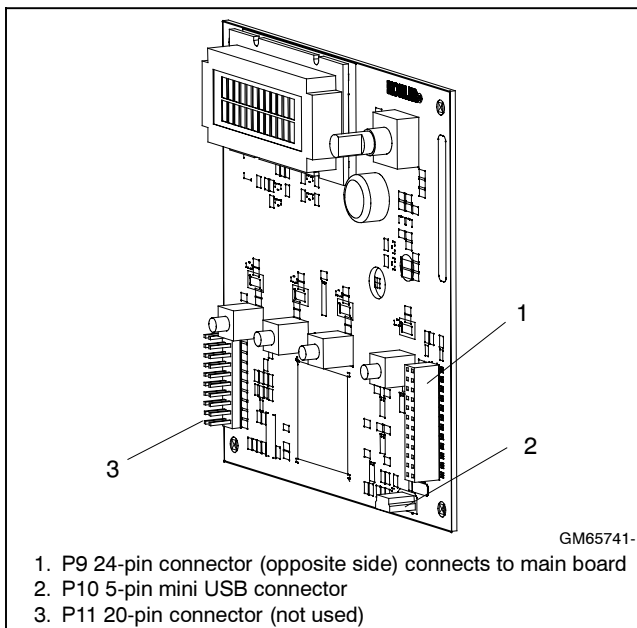

Figure 1-3 Digital Display Circuit Board Connectors

1.2.6 Main Logic Circuit Board

The main logic circuit board provides the terminal strips and connection sockets to connect the controller to the engine/generator, input/output connections, optional I/O module kit, and circuit protection fuses. See Figure 1-4 and Figure 1-5 for the circuit board connections. See Section 6, Accessories for more information.

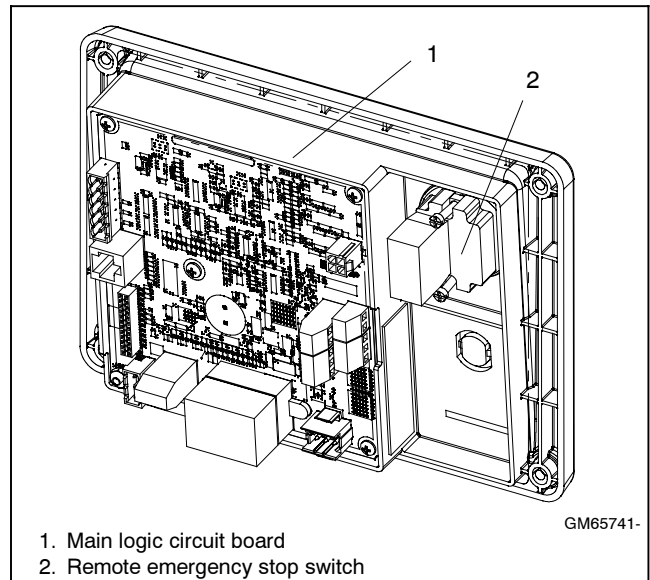

Figure 1-4 Main Circuit Board and Emergency Stop Switch

Circuit Board Connections

P1 (24-Pin) Connector for engine/generator wiring harness.

P2 (6-Pin) Connector for AC current.

(4) Push-on Connectors for V7/V8/V9/V0 for generator set output voltage connection.

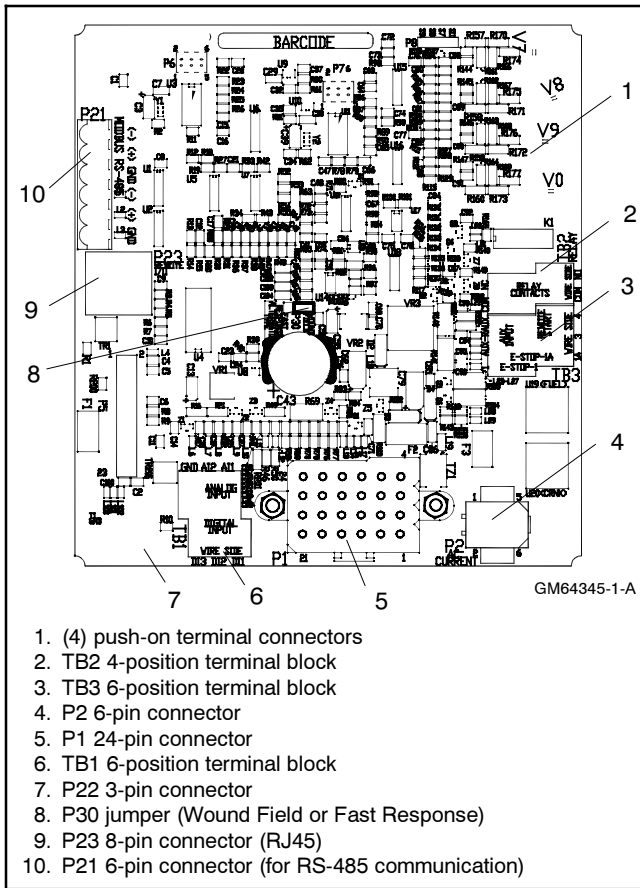

Figure 1-5 Main Circuit Board Connectors

P21 (6-Pin) Connector for (RS-485) connection of optional RSA or Modbus® communication.

P22 (3-Pin) Connector for engine ECM. Alternate CAN connection.

P23 (8-Pin) Connector (RJ45) for optional input/output (I/O) module circuit board.

Refer to Section 6.2, Accessory Connections for specific connections of the following terminal block connections.

TB1 (6-Position) Terminal Block for analog and digital inputs.

TB2 (4-Position) Terminal Block for K1 relay outputs.

TB3 (6-Position) Terminal Block for E-stop, remote start contacts, and aux. input connections.

1.2.7 Terminal Jumper

A circuit board P30 jumper is set based on alternator type—Wound Field (300 kW and larger) or Fast Response (less than 350 kW). The jumper is factory set and needs no further adjustment. See Figure 1-5 for location of the P30 jumper.

Modbus® is a registered trademark of Schneider Electric.

1.2.8 Communication Ports

The main logic circuit board contains a single mini USB communication port for PC connections, see Figure 1-6. For Modbus® communication using RS-485, see Figure 1-5 (P21). Refer to the List of Related Materials in the Introduction for corresponding SiteTech™ software and/or communication installation information.

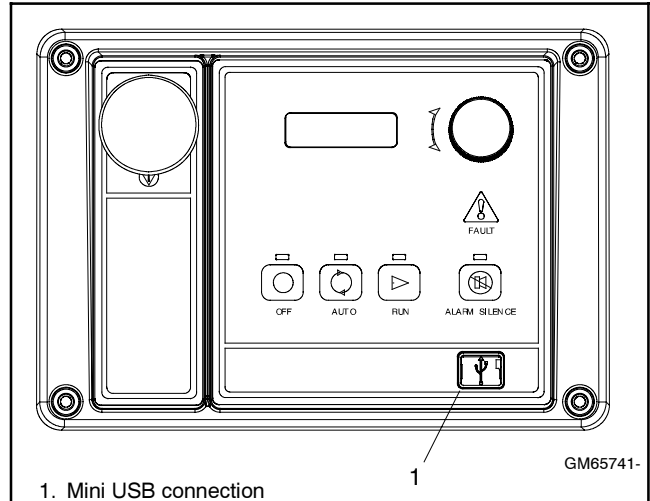

Figure 1-6 Communication Port

1.2.9 Fuses

AC Circuit Fuses (TB5). Fuses are located inside the generator set control box. See Figure 1-7

- **1.5-Amp (V7)** fuse protects L1 sensing input to interconnection circuit board.
- **1.5-Amp (V8)** fuse protects L2 sensing input to interconnection circuit board.
- **1.5-Amp (V9)** fuse protects L3 sensing input to interconnection circuit board.

DC Circuit Fuses are located on the controller circuit board. See Figure 1-8.

- **1-Amp (F1)** auto-resettable, fuse protects the controller circuits.
- **1-Amp (F2)** auto-resettable fuse protects the controller circuits.
- **12-Amp (F3)** non-replaceable fuse protects the engine/starting circuitry and accessories.

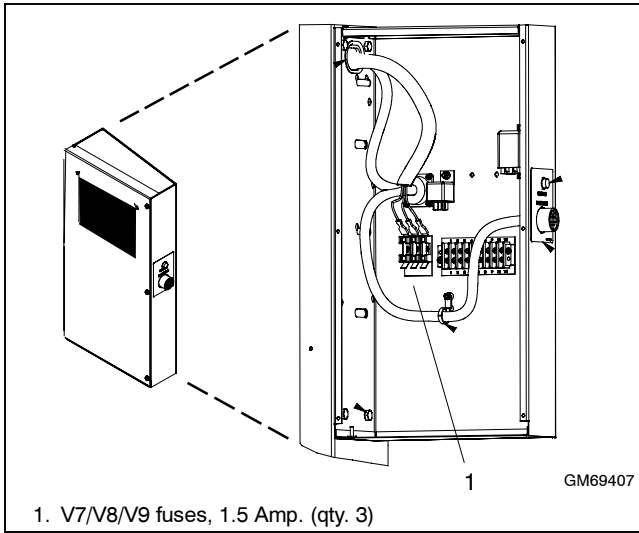

1. V7/V8/V9 fuses, 1.5 Amp. (qty. 3)

Figure 1-7 AC Circuit Fuses in Control Box

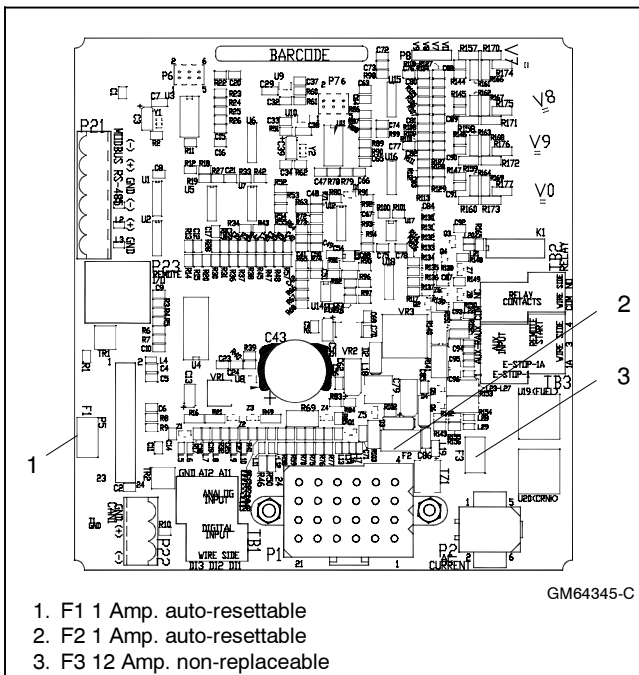

1. F1 1 Amp. auto-resettable
 2. F2 1 Amp. auto-resettable
 3. F3 12 Amp. non-replaceable

Figure 1-8 Controller DC Fuses

1.3 Controller Logic Specifications

The controller logic specifications section is an overview of the various features and functions of the controller. Certain features function only when optional accessories are connected. See Section 2, Operation, for details.

The default selection time delays and digital outputs are factory set and adjustable. Data entries require using a PC and SiteTech™ software. See the SiteTech™ software operation manual for details.

Inhibit Time Delay. The inhibit time delay is the time period following crank disconnect during which the generator set stabilizes and the controller does not detect a fault or status event. Select the desired inhibit time delay from 0 to 60 seconds.

Time Delay (Shutdown or Warning). The time delay follows the inhibit time delay. The time delay is the time period between when the controller first detects a fault or status event and the controller warning or shutdown lamp illuminates. The delay prevents nuisance alarms. Select the desired time delay from 0 to 60 seconds.

1.3.1 Status Event and Fault Specifications

The Factory-Defined Settings List contains all status events and faults with ranges and time delays including items that do not have user adjustments.

Note: The engine ECM may limit the crank cycle even if the controller is set to a longer time period.

Factory-Defined Settings List

Description	Controller Display Message	Alarm Horn	Fault Lamp <small>Warning Shutdown</small>	Write Access <small>Display SiteTech</small>	GenSet Mode <small>Always Running Stopped</small>	Range Setting	Default Selection	Time Delay Range (sec.)	Default Time Delay (sec.)
Engine Functions									
Critically high fuel level (diesel-powered models only) *	Fuel Level Critically High	On	W			0-100%	95%	0-10	5
ECM communications loss	ECM Comm Err Shutdwn	On	S					Fixed	10
ECM diagnostics (multiple inputs) †	ECM xxxxxx Warning	On	W						
ECM diagnostics (multiple inputs) †	ECM xxxxxx Shutdwn	On	S						
ECM faults (address conflict)	ECM Addr Err Shutdwn	On	S						
ECM faults (model mismatch)	ECM Mismatch Shutdwn	On	S			0-255	0		
Engine over speed	Eng Speed High Shutdwn	On	S	S	A	105-120%	115%		
Engine start aid active	Starting Aid Notice								
Engine under speed	Eng Speed Low Shutdwn	On	S	S	A	75-95%	85%		
Fuel tank leak *	Fuel Leak Warning	On	W						
Fuel tank leak *	Fuel Leak Shutdwn	On	S						
High battery voltage	Battery High Warning	On	W	S	A	110-135%	125%	Fixed	10
High coolant temperature	Coolnt Temp High Warning	On	W					0-10 (0-30 inhibit)	0 (0 inhibit)
High coolant temperature	Coolnt Temp High Shutdwn	On	S					0-10 (0-30 inhibit)	0 (0 inhibit)
High fuel level (diesel-powered models only) *	Fuel Level High Warning	On	W			0-100%	90%	0-10	5
Low battery voltage	Battery Low Warning	On	W	S	A	80-105%	100%	Fixed	90
Low coolant level *	Coolant Lvl Low Shutdwn	On	S					Fixed	5
Low coolant temperature	Coolant Temp Low Warning	On	W			Fixed	16°C (60°F)	0-10 (0-30 inhibit)	5 (0 inhibit)
Low cranking voltage	Lo Crank Vlt Warning	On	W			Fixed	60%	Fixed	6
Low engine oil level *	Oil Level Low Warning	On	W						
Low engine oil level *	Oil Level Low Shutdwn	On	S						
Low fuel level (diesel models) *	Fuel Level Low Warning	On	W			0-100%	35%	0-10	10
Low fuel level (diesel models) *	Fuel Level Low Shutdwn	On	S			0-100%	5%	0-10	0
Low fuel pressure (gas models) *	Fuel Press Low Warning	On	W						
Low oil pressure	Oil Press Low Warning	On	W					Fixed (Fixed inhibit)	0 (30 inhibit)
Low oil pressure	Oil Press Low Shutdwn	On	S					Fixed (Fixed inhibit)	5 (30 inhibit)
No coolant temperature signal	Temp Sig Loss Shutdwn	On	S						
No oil pressure signal	Press Sig Loss Shutdwn	On	S					Fixed	5
Overcrank	Over Crank Shutdwn	On	S					Fixed	(30 inhibit)
Speed sensor fault	Spd Sens Flt Warning	On	W						

Description	Controller Display Message	Alarm Horn	Fault Lamp Warning Shutdown	Write Access Display SiteTech	GenSet Mode Always Running Stopped	Range Setting	Default Selection	Time Delay Range (sec.)	Default Time Delay (sec.)
General Functions									
Alarm silence, 0-Auto only (NFPA 110), 1-Always	AlarmSilenceMode			S	A	0-1	1		
Aux. inputs 0-5 VDC, 1 analog	Aux Input Warning	On	W			0-100%	100%	0-10	0
Aux. inputs 0-5 VDC, 1 analog	Aux Input Shutdwn	On	S			0-100%	100%	0-10	0
Auxiliary inputs, up to 3 digital (2 additional digital inputs available with I/O module option)	Aux Input Warning	On	W					0-10 (0-30 inhibit)	0 (0 inhibit)
Auxiliary inputs, up to 3 digital (2 additional digital inputs available with I/O module option)	Aux Input Shutdwn	On	S					0-10 (0-30 inhibit)	0 (0 inhibit)
Backup parameters loaded	Backup Pars Status								
Battery charger fault *	Batt Chg Flt Warning	On	W						
Chicago code active *	Auto Locked Notice								
Common fault	Common Fault Shutdwn	On	S						
Common warning	Common Warng	On	W						
Default parameters loaded	Default Pars Warning	On	W						
Emergency stop	Emerg Stop Shutdwn	On	S						
Engine cooldown (delay) active	Eng Cooldown Notice								
Engine start delay active	Start Delay Notice								
Engine started	Engine Start Status								
Engine stopped	Engine Stop Status								
EPS supplying load	Emerg Pwr On Notice								
File system error (controller fault)	File Error Shutdwn	On	S						
Generator running	Gen Running Notice								
Input/output (optional module board) communication loss	OB1 Com Loss	On	W						
Internal failure	Intern Error Shutdwn	On	S						
Measurement Units, 0-English, 1-Metric	Measurement Display			DS	A	0-1	1		
Metering communication loss	MeterCommLos Shutdwn	On	S						
NFPA 110 alarm active	NFPA Alarm Notice								
Not in auto (master control buttons)	Not In Auto Warning	On	W						
Prime power application, 0-Standby, 1-Prime	Power Type			DS	A	0-1	0		
Remote start	Remote Start Status								
System ready	System Ready Status								
System timer failed	Timer Error Notice								
Generator Functions									
AC sensing loss	AC Sens Loss Warning	On	W						
AC sensing loss	AC Sens Loss Shutdwn	On	S					Fixed	3
Alternator protection	Alt Protect Shutdwn	On	S						
Ground fault input *	Ground Fault Warning	On	W						
kW overload	Total Power High Shutdwn	On	S			Fixed	102% standby, 112% prime	Fixed	60
Locked rotor (failed to crank)	Locked Rotor Shutdwn	On	S	S	A			1-5	5
Overfrequency	Freq High Shutdwn	On	S			102-140%	110%	Fixed	10

Description	Controller Display Message	Alarm Horn	Fault Lamp Warning Shutdown	Write Access Display SiteTech	GenSet Mode Always Running Stopped	Range Setting	Default Selection	Time Delay Range (sec.)	Default Time Delay (sec.)
Overvoltage (each phase)	Volts (L1-L2, L2-L3, or L3-L1) High Shutdwn	On	S	S	A	105-135%	120%	2-10	2
Power rating	Pwr Rating			DS	S	10-5000	275		
System frequency	System Freq			DS	S	50-60	60		
System voltage	System Volt			DS	S	110-600	208		
Underfrequency	Frequency Low Shutdwn	On	S			80-95%	90%	Fixed	10 ST 60 LT
Undervoltage (each phase)	Volts (L1-L2, L2-L3, or L3-L1) Low Shutdwn	On	S	S	A	70-95%	80%	5-30	10
Voltage/phase configuration, 0-Single phase, 1-Single phase dogleg, 2-three phase wye, 3-three phase delta	SystemPhase			DS	S	0-3	2		
Voltage regulator average voltage adjustment	VR Volt Adj			DS	R	108-600	208		
(Voltage) regulator communication loss	RegCommLoss Shutdwn	On	S						
SiteTech Read/Write Display Only									
Current transformer ratio ‡				S	S	1-	1200		
ECM power				S	S	0-1	0		
Engine cooldown delay				S	A			0-600	300
Engine (cyclic) crank on				S	A			10-30	15
Engine (cyclic) crank pause				S	A			1-60	15
Engine ECM start delay				S	A			0-300	0
Engine idle duration				S	A			0-60	60
Engine no. of (cyclic) crank cycles				S	S	1-6	3		
Engine restart delay				S	A			1-10	10
Engine start aid delay				S	A			0-10	0
Engine start delay				S	A			0-300	0
System battery voltage ‡				S	S	12-24	12		
Voltage regulator gain				S	R	1-255	128		
Voltage regulator stability adjust				S	R	1-255	128		
Voltage regulator, volts per Hertz slope				S	R	1-10	5		
Voltage regulator, volts per Hertz cutin frequency				S	R	42-62	57.5		

* Some functions require optional input sensors or are engine ECM dependent on some generator set models.

† ECM inputs are engine manufacturer dependent.

‡ Changeable only by resetting the controller with a personality profile (SiteTech 1.4 or higher).

ST-Short Term, LT-Long Term

1.3.2 Voltage Regulator and Calibration Specifications

The controller has a voltage regulation function that is internal to the processor. This means that no external voltage regulator is necessary. The voltage regulation of the controller uses root mean square (rms) sensing for fast response to changes in indicated and regulated voltages resulting in excellent regulation accuracy.

1.3.3 Voltage Regulator Adjustments

The descriptions of the voltage regulator adjustments and features follow. Refer to the Factory-Defined Settings List shown in 1.3.1 for voltage regulator adjustments. See Appendix C, Voltage Regulator Definitions and Adjustments, for additional information and to customize adjustments for specific applications.

Voltage Adjustment. The voltage adjustment allows the user to enter the desired generator set output level. This regulated level setting is the average of the three line-to-line voltages in three-phase configurations or L1-to-L2 in single phase configurations.

Submenus display the individual line-to-line voltages. These voltages are for reference only and are relevant in unbalanced load conditions. The voltage adjust setpoint can be changed to accommodate an important phase in an unbalanced system.

Underfrequency Unload Frequency Setpoint. This adjustment affects the voltage droop (volts per Hz) when load is applied and underfrequency occurs. The underfrequency unload setting defines the setpoint where underfrequency starts. Any frequency below the setpoint causes the voltage to drop thus reducing the load allowing the engine speed to recover according to the underfrequency unload slope setting.

Engine speed recovery depends upon characteristics such as engine make, fuel type, load types, and operating conditions. The underfrequency unload setting should match the engine speed recovery characteristics for the application.

Underfrequency Unload Slope. This setting determines how much the voltage drops during an underfrequency condition. Typically, applying a large electrical load causes a dip in engine speed and frequency. The voltage regulator reduces voltage, allowing engine speed recovery. The volts-per-Hz setting determines the amount of voltage drop.

Regulator Gain. Regulator gain refers to the gain of the control system. Generally, the higher the gain the faster the system responds to changes and the lower the gain, the more stable the system.

If the voltage is slow to recover when loads are applied or removed, increase the regulator gain. If the voltage is unstable, decrease the regulator gain.

2.1 Prestart Checklist

To ensure continued satisfactory operation, perform the following checks or inspections before or at each startup, as designated, and at the intervals specified in the service schedule. In addition, some checks require verification after the unit starts.

Air Cleaner. Check for a clean and installed air cleaner element to prevent unfiltered air from entering engine.

Air Inlets. Check for clean and unobstructed air inlets.

Battery. Check for tight battery connections. Consult the battery manufacturer's instructions regarding battery care and maintenance.

Coolant Level. Check the coolant level according to the cooling system maintenance information.

Note: Block Heater Damage. The block heater will fail if the energized heater element is not immersed in coolant. Fill the cooling system before turning on the block heater. Run the engine until it is warm, and refill the radiator to purge the air from the system before energizing the block heater.

Drive Belts. Check the belt condition and tension of the radiator fan, water pump, and battery charging alternator belt(s).

Exhaust System. Check for exhaust leaks and blockages. Check the silencer and piping condition and check for tight exhaust system connections.

Inspect the exhaust system components (exhaust manifold, exhaust line, flexible exhaust, clamps, silencer, and outlet pipe) for cracks, leaks, and corrosion.

- Check for corroded or broken metal parts and replace them as needed.
- Check for loose, corroded, or missing clamps and hangers. Tighten or replace the exhaust clamps and/or hangers as needed.
- Check that the exhaust outlet is unobstructed.
- Visually inspect for exhaust leaks (*blowby*). Check for carbon or soot residue on exhaust components. Carbon and soot residue indicates an exhaust leak. Seal leaks as needed.

Fuel Level. Check the fuel level and keep the tank(s) full to ensure adequate fuel supply.

Oil Level. Maintain the oil level at or near, not over, the full mark on the dipstick.

Operating Area. Check for obstructions that could block the flow of cooling air. Keep the air intake area clean. Do not leave rags, tools, or debris on or near the generator set.

2.2 Exercising Generator Set

Operate the generator set under load once each week for one hour. Perform the exercise in the presence of an operator when the generator set does not have an automatic transfer switch with an exercise option.

During the exercise period apply a minimum of 35% load based on the nameplate standby rating, unless otherwise instructed in the engine operation manual.

The operator should perform all of the prestart checks before starting the manual exercise procedure. Start the generator set according to the starting procedure in Section 2.3, Controller Operation. While the generator set is operating, listen for a smooth-running engine and visually inspect generator set for fluid or exhaust leaks.

The generator set controller does not provide weekly scheduled exercise periods. For scheduled exercise periods, refer to the automatic transfer switch (if equipped) literature.

2.3 Controller Operation

The controller operation includes several types of starting and stopping functions as detailed in the following paragraphs. The controller master control switch buttons, lamps, and alarm horn functions are summarized in Figure 2-1.

Button Mode	Generator Set Status	Button Lamp	Fault Lamp	Alarm Horn	Alarm Silence Button	Alarm Horn Lamp	Controller Display	
AUTO	Off	Green	—	Off	—	—	Scrolling Overview Menu Only	
	On (or Cranking)		—	Off	—			
	Running and then Off		Red	On	—	—	Shutdown Message	
		Off	Pressed	Yellow				
OFF/RESET	Off	Red	Yellow	On	—	—	Not In Auto Warning	
				Off	Pressed	Yellow		
RUN (unit fails to start)	Off (or Cranking)	Yellow	Yellow	On	—	—	Not in Auto Warning	
				Off	Pressed	Yellow		
	Off		Red	On	—	—	Locked Rotor Shutdown (or other shutdown message)	
				Off	Pressed	Yellow		
RUN (unit starts)	Off (or Cranking)	Yellow	Yellow	On	—	—	Not in Auto Warning	
				On	Off	Pressed		Yellow
	Running and then Off		Yellow	Red	On	—	—	Shutdown Message
					Off	Pressed	Yellow	

Figure 2-1 Master Control Button Function Summary

2.3.1 Starting

Local Starting

Press the master control RUN button to start the generator set at the controller.

Note: The alarm horn sounds and the Not-In-Auto Warning display appears whenever the generator set master control button is not in the AUTO mode.

Note: The transient start/stop function of the controller prevents accidental cranking of the rotating engine. The generator set stops and recranks when the OFF/RESET button is momentarily pressed and then the RUN button is pressed.

Auto Starting

Press the master control AUTO button to allow startup by the automatic transfer switch or remote start/stop switch (connected to controller terminals 3 and 4).

Terminals 3 and 4 connect to a circuit that automatically starts the generator set crank cycle when an external source closes the circuit.

Note: The controller provides up to 30 seconds of programmable cyclic cranking and up to 60 seconds rest with up to 6 cycles. The default setting is 15 seconds cranking and 15 seconds rest for 3 cycles. Make cyclic cranking adjustments using SiteTech™ software.

Prime Power Switch

The controller has an optional prime power mode of operation. The prime power mode requires installation of an optional prime power switch kit. See Section 6, Accessories, for instructions on how to install the optional prime power switch kit. The prime power switch kit prevents engine starting battery drain when the generator set is shut down and no external battery charging is available.

Move the prime power switch located on the junction box to the CONTROLLER ON position before attempting to start the generator set. When the prime power mode is off, all controller functions including the digital display, LEDs, and alarm horn are operative.

Stop the generator set using the stopping procedures in Section 2.3.2 before placing the generator set in the prime power mode. Move the prime power switch located on the junction box to the CONTROLLER OFF position. When the generator set is in the prime power mode, all controller functions including the digital display, LEDs, alarm horn, and communications are inoperative.

2.3.2 Stopping (User Stopping and Fault Shutdown)

Normal Stopping

Run the generator set without load for 5 minutes to ensure adequate engine cooldown.

The controller has a programmable cooldown timer that functions only when the master control button is in the AUTO mode. To stop the generator set, press the generator set master control OFF/RESET button and wait until the generator set comes to a complete stop.

Note: The cooldown cycle times out before the generator set stops when a remote switch or automatic transfer switch initiates the generator set start/stop sequence.

Emergency Stopping

Use the controller emergency stop switch or optional remote emergency stop for immediate shutdown.

The emergency stop switch bypasses the time delay engine cooldown and immediately shuts down the generator set.

Note: Use the emergency stop switch(es) for emergency shutdowns only. Use the generator set master control OFF/RESET button for normal shutdowns.

The controller fault lamp lights and the unit shuts down when the local or remote emergency stop switch activates.

2.3.3 Emergency Stop Switch Resetting

Use the following procedure to reset the generator set after shutdown by a local or remote emergency stop

switch. Refer to Section 2.3.8, Controller Resetting procedure, to restart the generator set following a fault shutdown.

1. Investigate and correct the cause of the emergency stop.
2. Reset the optional remote emergency stop switch by replacing the glass piece, when equipped. Additional glass rods are available as a service part. Reset the controller emergency stop switch by pulling the switch dial outward.
3. Press the generator set master control OFF/RESET button.
4. After resetting all faults using the controller reset procedure in Section 2.3.8, press the generator set master control RUN or AUTO button to restart the generator set. The generator set will not crank until the reset procedure completes.

2.3.4 System Status Lamps

The (OFF/RESET-AUTO-RUN) master control buttons indicate the status condition with an integrated lamp at the button.

The green lamp illuminates on the master control AUTO (automatic start) button indicating the system senses no faults and the unit is ready to start by remote command.

The red lamp illuminates on the master control OFF/RESET button indicating the generator set is stopped.

The yellow lamp illuminates on the master control RUN button indicating the generator set is cranking or running from a local command.

Only one of the three master control button lamps will illuminate at any given time.

2.3.5 System Fault Warning Lamp with Digital Displays

The system FAULT lamp glows yellow and the alarm horn sounds indicating a warning fault but does not shut down the generator set. The fault lamp illuminates yellow and the alarm horn sounds when the fuel tank level on diesel-fueled models approaches empty. This fault requires an optional low fuel level switch for the lamp to function. The local display shows *Fuel Level Low Warning*. See Section 2.3.8, Controller Resetting procedure, for instructions on resetting a system warning.

When the system warning lamp is on and no message displays, rotate the selector dial to view messages. When the system warning continues, it may lead to a fault and cause a system shutdown.

Use the Silence Alarm button to silence the alarm horn at the operator's discretion.

If the controller is setup for an NFPA 110 application, press the AUTO button before silencing the alarm horn. The alarm horn cannot be silenced unless the master control button is in the AUTO mode. See 2.3.7 Status and Notice Digital Displays for more information.

Note: Text shown in *italics* in this section of the manual represents digital display messages.

AC Sensing Loss. The fault lamp illuminates yellow and the alarm horn sounds when the controller does not detect the nominal generator set AC output voltage after crank disconnect. The controller displays *AC Sens Loss Warning*.

Auxiliary Input (Warning). The fault lamp illuminates yellow and the alarm horn sounds when an auxiliary digital or analog input signals the controller. The digital inputs do not function during first the 30 seconds after startup. Use SiteTech™ software to define inputs as shutdowns or warnings. The local display shows *Aux Input Warning*.

Battery Charger Fault. The fault lamp illuminates yellow and the alarm horn sounds when the battery charger malfunctions. This fault feature requires an optional battery charger with a malfunction output for the lamp to function. Local display shows *Batt Chg Flt Warning*.

Common Warning. The fault lamp illuminates yellow and the alarm horn sounds when the controller is signaled by a common warning. Use SiteTech™ software to activate the common warning. The local display shows *Common Warng*. The common warning comprises all of the warnings under a single alert.

Critical High Fuel Level (diesel-powered models only). The fault lamp illuminates yellow and the alarm horn sounds when the fuel tank level on diesel models approaches full. This fault requires an optional critical high fuel switch and fuel tank for the lamp to function. The local display shows *Fuel Level Critically High*.

Default Parameters Loaded. The fault lamp illuminates yellow and the alarm horn sounds when the controller detects that the default parameter software was loaded using SiteTech™ software. The local display shows *Default Pars Warning*.

ECM Diagnostics (Multiple Engine Inputs). The fault lamp illuminates yellow and the alarm horn sounds when ECM diagnostics signals the controller. The local display shows *ECM xxxxx Warning*. The specific display (xxxxx) will be a brief message or fault code that is engine manufacturer dependant. The engine literature provides the fault code description and further information.

Fuel Tank Leak (diesel-powered models only). The fault lamp illuminates yellow and the alarm horn sounds when the fuel tank signals a leak of the inner tank. This fault requires an optional fuel tank leak switch for the lamp to function. The local display shows *Fuel Leak Warning*.

Ground Fault. The fault lamp illuminates yellow and the alarm horn sounds when a user-supplied ground fault detector signals the controller. The local display shows *Ground Fault Warning*.

High Battery Voltage. The fault lamp illuminates yellow and the alarm horn sounds when the battery voltage rises above the preset level for more than 10 seconds. The local display shows *Battery High Warning*. Figure 2-2 shows high battery voltage specifications. The high battery voltage feature monitors the battery and battery charging system in the generator set operating and off modes.

Engine Electrical System Voltage	High Battery Voltage Range	High Battery Voltage Default Setting
12	13.2-16.2	15
24	26.4-32.4	30

Figure 2-2 High Battery Voltage Specs

High Coolant Temperature. The fault lamp illuminates yellow and the alarm horn sounds when the engine coolant temperature approaches the shutdown range. The high coolant temperature warning does not function during the preset inhibit time delay period after startup. The local display shows *Coolnt Temp High Warning*.

High Fuel Level (diesel-powered models only). The fault lamp illuminates yellow and the alarm horn sounds when the fuel tank level on diesel models approaches near full. This fault requires an optional high fuel switch and fuel tank for the lamp to function. The local display shows *Fuel Level High Warning*.

Input/Output Communication Loss. The fault lamp illuminates yellow and the alarm horn sounds when the controller loses the input/output communication signal from the optional I/O module board. The local display shows *OB1 Com Loss*.

Low Battery Voltage. The fault lamp illuminates yellow and the alarm horn sounds when the battery voltage drops below a preset level for more than 90 seconds. The local display shows *Low Battery Warning*. See Figure 2-3 for low battery voltage specifications.

Engine Electrical System Voltage	Low Battery Voltage Range	Low Battery Voltage Default Setting
12	9.6-12.6	12
24	19.2-25.2	24

Figure 2-3 Low Battery Voltage Specs

The low battery voltage feature monitors the battery and battery charging system in the generator set operating and off modes. The controller logic inhibits the low battery voltage warning during the crank cycle.

Low Coolant Temperature. The fault lamp illuminates yellow and the alarm horn sounds when the engine coolant temperature is low. The low coolant temperature warning does not function during the preset inhibit time delay period after startup. The local display shows *Coolant Temp Low Warning*.

Low Cranking Voltage. The fault lamp illuminates yellow and the alarm horn sounds when the battery voltage drops below 60% of the nominal voltage (12 VDC or 24 VDC) for more than 6 seconds during the crank cycle. The local display shows *Lo Crank Vlt Warning*.

Low Engine Oil Level. The fault lamp illuminates yellow and the alarm horn sounds because of low engine oil level. This fault feature requires an optional low engine oil level sensor for the lamp to function. Local display shows *Oil Level Low Warning*.

Low Fuel Level (diesel-powered models only). The fault lamp illuminates yellow and the alarm horn sounds when the fuel tank level on diesel-fueled models approaches empty. This fault requires an optional low fuel level switch for the lamp to function. The local display shows *Fuel Level Low Warning*.

Low Fuel Pressure (gas-powered models only). The fault lamp illuminates yellow and the alarm horn sounds when low fuel pressure on gaseous-fueled models occurs. This fault requires an optional low fuel pressure switch for the lamp to function. The local display shows *Fuel Press Low Warning*.

Low Oil Pressure. The fault lamp illuminates yellow and the alarm horn sounds when the engine oil pressure approaches the shutdown range. The low oil pressure warning does not function during first the 30 seconds after startup. The local display shows *Oil Press Low Warning*.

Not in Auto (Generator Master Control Switches). The fault lamp illuminates yellow and the alarm horn sounds when the generator set master control button is in the RUN or OFF/RESET mode. The local display shows *Not In Auto Warning*.

Speed Sensor Fault. The fault lamp illuminates yellow and the alarm horn sounds when the speed signal is absent for one second while the generator set runs. The local display shows *Spd Sens Flt Warning*.

2.3.6 System Fault Shutdown Lamp With Digital Displays

The system FAULT lamp glows red, the alarm horn sounds, and the unit shuts down to indicate a fault shutdown under the following conditions. See Section 2.3.8, Controller Resetting procedure, for information on resetting a system shutdown.

Use the Alarm Off button to silence the alarm horn at the operator's discretion.

If the controller is setup for an NFPA 110 application, press the AUTO button before silencing the alarm horn. The alarm horn cannot be silenced unless the master control button is in the AUTO mode. See 2.3.7 Status and Notice Digital Displays for more information.

Note: Text shown in *italics* in this section of the manual represents digital display messages.

AC Sensing Loss. The fault lamp illuminates red, the alarm horn sounds, and the unit shuts down when the controller does not detect the nominal generator set AC output voltage for more than 3 seconds after crank disconnect. The controller displays *AC Sens Loss Shutdwn*.

Alternator Protection. The fault lamp illuminates red and the unit shuts down because of an alternator overload or short circuit. The local display shows *Alt Protect Shutdwn*. See Appendix D, Alternator Protection for more information.

Auxiliary Input (Shutdown). The fault lamp illuminates red, the alarm horn sounds, and the unit shuts down when an auxiliary digital or analog inputs signals the controller. The digital inputs do not function during first the 30 seconds after startup. Use SiteTech™ software to define inputs as shutdowns or warnings. The local display shows *Aux Input Shutdwn*.

Common Fault. The fault lamp illuminates red, the alarm horn sounds, and the unit shuts down when the controller is signaled by a common fault. Use SiteTech™ software to activate the common fault shutdown. The local display shows *Common Fault Shutdwn*. The common fault comprises the following shutdowns under a single alert.

- Emergency stop
- Engine over speed
- High coolant temperature
- Low oil pressure
- Overcrank

ECM Address Conflict. The fault lamp illuminates red, the alarm horn sounds, and the unit shuts down when the controller detects an error with the ECM address. The local display shows *ECMAddr Err Shutdwn*.

ECM Communications Loss. The fault lamp illuminates red, the alarm horn sounds, and the unit shuts down when the ECM communication link is disrupted. The local display shows *ECM Comm Err Shutdwn*.

ECM Diagnostics (Multiple Engine Inputs). The fault lamp illuminates red, the alarm horn sounds, and the unit shuts down when ECM diagnostics signals the controller. The local display shows *ECM xxxxx Shutdwn*. The specific display (xxxxx) will be a brief message or fault code that is engine manufacturer dependant. The engine literature provides the fault code description and further information.

ECM Model Mismatch. The fault lamp illuminates red, the alarm horn sounds, and the unit shuts down when the controller detects an error with the ECM model. The local display shows *ECM Mismatch Shutdwn*.

Emergency Stop. The fault lamp illuminates red, the alarm horn sounds, and the unit shuts down when the local or optional remote emergency stop switch activates. The local display shows *Emerg Stop Shutdwn*.

Engine Over Speed. The fault lamp illuminates red, the alarm horn sounds, and the unit shuts down immediately when the governed frequency on 50 and 60 Hz models exceeds the over speed setting. The local display shows *Eng Speed High Shutdwn*.

Engine Under Speed. The fault lamp illuminates red, the alarm horn sounds, and the unit shuts down immediately when the governed frequency on 50 and 60 Hz models drops below the under speed setting. The local display shows *Eng Speed Low Shutdwn*.

File System Error. The fault lamp illuminates red, the alarm horn sounds, and the unit shuts down when the internal controller diagnostics detect a firmware file error. The local display shows *File Error Shutdwn*.

Fuel Tank Leak (diesel-powered models only). The fault lamp illuminates red, the alarm horn sounds, when the fuel tank signals a leak of the inner tank. This fault requires an optional fuel tank leak switch for the lamp to function. The local display shows *Fuel Leak Shutdwn*.

High Coolant Temperature. The fault lamp illuminates red, the alarm horn sounds, and the unit shuts down because of high engine coolant temperature. The high coolant temperature shutdown does not function during the preset inhibit time delay period after startup. The local display shows *Coolnt Temp High Shutdwn*.

Note: The high engine temperature shutdown function and the low coolant level shutdown function are independent. A low coolant level condition may not activate the high engine temperature switch.

Internal Fault. The fault lamp illuminates red, the alarm horn sounds, and the unit shuts down when the internal diagnostics detect a controller malfunction. The local display shows *Intern Error Shutdwn*.

kW Overload. The fault lamp illuminates red, the alarm horn sounds, and the unit shuts down when the generator set supplies more than 102% of the rated standby output kW (or 112% of the rated prime power output kW) for more than 60 seconds. The local display shows *Total Power High Shutdwn*.

Locked Rotor (failed to crank). If none of the speed sensing inputs show engine rotation within the preset time delay of initiating engine cranking, the ignition and crank circuits turn off for the preset period and the cycle repeats. The fault lamp illuminates red, the alarm horn sounds, and the unit shuts down after the second cycle of the preset period of cranking. The local display shows *Locked Rotor Shutdown*.

Low Coolant Level. The fault lamp illuminates red, the alarm horn sounds, and the unit shuts down because of low coolant level. Shutdown occurs 5 seconds after low coolant level is detected. Local display shows *Coolant Lvl Low Shutdwn*.

Low Engine Oil Level. The fault lamp illuminates red, the alarm horn sounds, and the unit shuts down because of low engine oil level. This fault feature requires an optional low engine oil level sensor for the lamp to function. Local display shows *Oil Level Low Shutdwn*.

Low Fuel Level (diesel-powered models only). The fault lamp illuminates red, the alarm horn sounds, and the unit shuts down when the fuel tank level on diesel-fueled models approaches empty. This fault requires an optional low fuel level switch for the lamp to function. The local display shows *Fuel Level Low Shutdwn*.

Low Oil Pressure. The fault lamp illuminates red, the alarm horn sounds, and the unit shuts down because of low oil pressure. The shutdown occurs 5 seconds after the low pressure condition is detected. The low oil pressure shutdown does not function during first the 30 seconds after startup. The local display shows *Oil Press Low Shutdwn*.

Metering Communications Loss. The fault lamp illuminates red, the alarm horn sounds, and the unit shuts down when the metering to controller communication link is disrupted. The local display shows *MeterCommLos Shutdwn*.

No Coolant Temperature Signal. The fault lamp illuminates red, the alarm horn sounds, and the unit shuts down when the engine coolant temperature sender circuit is open. The local display shows *Temp Sig Loss Shutdwn*.

No Oil Pressure Signal. The fault lamp illuminates red, the alarm horn sounds, and the unit shuts down when the engine oil pressure sender circuit is open for more than 5 seconds. The local display shows *Press Sig Loss Shutdwn*.

Overcrank. The fault lamp illuminates red, the alarm horn sounds, and cranking stops when the unit does not start within the defined cranking period. The local display shows *Over Crank Shutdwn*. See Section 2.3.1, Auto Starting, and Section 1.3.1, Status Event and Fault Specifications for cyclic crank specifications.

Note: The controller is equipped with an automatic restart function. When speed drops below 25 Hz (750 rpm) while the engine is running, the unit attempts to recrank. The unit then follows the cyclic cranking cycle and, when the engine fails to start, will shut down on an overcrank fault condition.

Overfrequency. The fault lamp illuminates red, the alarm horn sounds, and the unit shuts down when the frequency is above the overfrequency setting. The local display shows *Freq High Shutdwn*. See Figure 2-4.

Overfrequency Setting Range	Time Delay	Overfrequency Default Setting
102%-140% of nominal	10 sec.	110% of nominal

Figure 2-4 Overfrequency Specs

Overvoltage (Each Phase). The fault lamp illuminates red, the alarm horn sounds, and the unit shuts down when the voltage exceeds the overvoltage setting for the preset time delay period. The local display shows *Volts (L1-L2, L2-L3, or L3-L1) High Shutdwn.* See Figure 2-5 for overvoltage specifications.

Note: Overvoltage can damage sensitive equipment in less than one second. Install separate overvoltage protection on online equipment requiring faster than 2-second shutdown.

Overvoltage Setting Range	Time Delay Range	Overvoltage Default Setting
105%-135% of nominal	2-10 sec.	120% at 2 sec.

Figure 2-5 Overvoltage Specs

Underfrequency. The fault lamp illuminates red, the alarm horn sounds, and the unit shuts down when the frequency drops below the underfrequency setting. The local display shows *Frequency Low Shutdwn.* See Figure 2-6 for underfrequency specifications.

Underfreq. Setting Ranger	Time Delay	Underfrequency Default Setting
80%-95% of nominal	10 sec. (short term) 60 sec. (long term)	90% of nominal

Figure 2-6 Underfrequency Specs

Undervoltage. The fault lamp illuminates red, the alarm horn sounds, and the unit shuts down when the voltage drops below the undervoltage setting for the time delay period. The local display shows *Volts (L1-L2, L2-L3, or L3-L1) Low Shutdwn.* See Figure 2-7 for undervoltage specifications

Undervoltage Setting Range	Time Delay Range	Undervoltage Default Setting
70%-95% of nominal	5-30 sec.	80% of nominal at 10 sec.

Figure 2-7 Undervoltage Specs

(Voltage) Regulator Communications Loss. The fault lamp illuminates red, the alarm horn sounds, and the unit shuts down when the voltage regulator to controller communication link is disrupted. The local display shows *RegCommLos Shutdwn.*

2.3.7 Status and Notice Digital Displays

Warnings and shutdown faults appear on the digital display and become part of the event history. Beyond the warnings and shutdowns there are several events which also appear on the digital display. Status is an event that is not an alert but is part of the event history. Notice is an alert that is not part of the event history.

The controller allows a selected number of changes by the user for setting up the controller application which are covered in this section.

Note: Text shown in *italics* in this section of the manual represents digital display messages.

Alarm Silence. This status message indicates whether the alarm horn can be silenced in any button mode (OFF/RESET-AUTO-RUN) or requires the AUTO button be pressed first compliant per NFPA 110. Use SiteTech™ software to change this setting. See Section 2.3.8, Controller Resetting procedure, for information on resetting the system.

The local display shows *AlrmSilence: Always* when the alarm horn can be silenced with the master control buttons in any position (default setting).

The local display shows *AlrmSilence: Auto Only* when the alarm horn can be silenced only when in the AUTO mode. The correct reset sequence requires pressing the OFF/RESET button, then pressing the AUTO button, and then pressing the ALARM SILENCE button.

Backup Parameters Loaded. This status message indicates that backup parameter firmware is now loaded on the controller using SiteTech™ software. The local display shows *Backup Pars Status.*

Chicago Code Active. This notice message indicates that a pass code is required to access the controller. Use SiteTech™ software to set up the feature. The local display shows *Auto Locked Notice.*

Emergency Power System (EPS) Supplying Load. This notice message indicates when the generator set supplies more than 1% of the rated standby output current. The local display shows *Emerg Pwr On Notice.*

Engine Cooldown (Delay) Active. This notice message indicates that the delay for engine cooldown is active where the generator set will continue to run after the OFF/RESET button is pressed. The unit will continue to run until the time delay times out. The local display shows *Eng Cooldown Notice.*

Engine Start Aid Active. This notice message indicates that the start aid is active and will energize an engine equipped preheat or ether system during the crank cycle. Use SiteTech™ software to set up this feature. The local display shows *Starting Aid Notice*.

Engine Start Delay Active. This notice message indicates that the delay for engine start is active where the generator set will not start right after the RUN button is pressed. The unit will start cranking after the time delay times out. The local display shows *Start Delay Notice*.

Engine Started. This status indicates that the generator set start circuit is closed allowing the engine to crank and run. The local display shows *Engine Start Status*.

Engine Stopped. This status indicates that the generator set start circuit is open causing the engine to shut down. The local display shows *Engine Stop Status*.

Generator Running. This notice indicates that the generator set has started and is running. The local display shows *Gen Running Notice*.

Generator Set Calibration (User Defined). This selectable display is in the GenSet Calibration Menu allowing the user to calibrate the controller and generator set. Use the Pushbutton/Rotary Selector Dial to navigate and select this feature.

Changes to this display must be done with the generator set running. The local display shows *Enter calib? No or Yes*. Select No to make no change. Select Yes to calibrate the following values:

- Volts L1-L2: x.x V
- Volts L2-L3: x.x V
- Volts L3-L1: x.x V
- Volts L1-N: x.x V
- Volts L2-N: x.x V
- Volts L3-N: x.x V
- Current L1: x.x A
- Current L2: x.x A
- Current L3: x.x A

The user can individually calibrate the values above or reset all of them. The local display *Reset all calib? No or Yes*. Select No to make no changes and exit GenSet Calibration. Select Yes to reset all of the values.

When calibrating voltage, the metered value and the number being entered as the calibrated value must be within 10% of the system operating voltage.

When calibrating current, the metered value must be at least 25% of the rated current on units smaller than 100 kW and at least 50 amps on units rated larger than 100 kW. The number being entered as the calibrated value must be within 10% of the metered value.

Measurement Units (User Defined). This selectable display is in the GenSet System Menu allowing the user to choose between Metric and English displays. Use the Pushbutton/Rotary Selector Dial to navigate and select this feature. Changes to this display can be done with the generator set running or stopped. The local display shows *Meas Units: Metric* or *Meas Units: English*.

NFPA 110 Alarm Active. This notice message indicates that the alarm for NFPA 110 is active. The fault lamp illuminates yellow (warning) or red (shutdown), the alarm horn sounds, and the units shuts down (if a shutdown fault is detected) when the NFPA 110 fault signals the controller. The local display shows the respective fault message. The NFPA 110 faults include:

- Battery charger fault
- EPS supplying load
- High battery voltage
- High coolant temperature shutdown
- High coolant temperature warning
- High engine speed
- Low battery voltage
- Low coolant level
- Low coolant temperature warning
- Low fuel (level or pressure)
- Low oil pressure shutdown
- Low oil pressure warning
- Master switch not in auto
- Overcrank

Remote Start. This status indicates that the generator set start circuit was closed from a remote location allowing the engine to crank and run. The remote location is typically a set of contacts on a transfer switch or remote start switch. The local display shows *Remote Start Status*.

System Ready. This status indicates that the generator set is in the AUTO mode and available to start if the start circuit is closed. The local display shows *System Ready*.

System Timer Failed. This notice indicates that the controller timer logic has failed to time out a designated function. The local display shows *Timer Error Notice*.

Voltage Regulator Adjustment (User Defined). This feature is in the Voltage Regulator Menu allowing the user to fine adjust the output voltage. Use the Pushbutton/Rotary Selector Dial to navigate and select this feature. Changes to this display must be done with the generator set running. The local display shows *Enter volt reg? No or Yes*. Select No to exit the voltage regulator menu. Select Yes to change the local display *VR Volt Adj: xxx.x V*.

2.3.8 Controller Resetting (Following System Shutdown or Warning)

Use the following procedure to restart the generator set after a system shutdown or to clear a warning lamp condition. This procedure includes the resetting of the optional remote annunciator.

Refer to Section 2.3.3, Emergency Stop Switch Reset Procedure, to reset the generator set after an emergency stop.

1. Disconnect the generator set load using the line circuit breaker or automatic transfer switch.
2. Correct the cause of the fault shutdown or warning. See the Safety Precautions and Instructions section of this manual before proceeding.
3. Start the generator set by pressing the generator set master control OFF/RESET button and then press the RUN button.

When equipped, the remote annunciator alarm horn sounds. Press the ALARM SILENCE/LAMP TEST button to stop the alarm horn. The lamp turns off.

4. Test operate the generator set to verify correction of the shutdown cause.
5. Press the generator set master control OFF/RESET button to stop the generator set.
6. Press the generator set master control AUTO button.
7. Silence the controller alarm horn by pressing the ALARM SILENCE button.
8. Reconnect the generator set load via the line circuit breaker or automatic transfer switch.
9. When equipped, the remote annunciator alarm horn sounds. Press the ALARM SILENCE/LAMP TEST button to stop the alarm horn. The lamp turns off.

2.4 Menu Displays

Use the Menu Summary List section after reading and understanding the features of the pushbutton/rotary selector dial. See Section 1.2.3, Digital Display.

The Menu Summary List provides a quick reference to the digital display data. Some digital display data may not be identical to your display due to generator set application differences. The closed bullet items represent main level data and the open bullet items are sub-level data. The Menu Summary List indicates items that are user selectable. Use SiteTech™ software for changing all other programmable information.

Section 2.6, Reviewing the Menu Displays, provides a digital display menu overview and explains the navigation using the pushbutton/rotary selector dial.

Menu Summary List (Legend: ● First level submenu, ○ second level submenu)

Overview Menu	Generator Metering Menu	GenSet System Menu	Voltage Regulator Menu (Version 3.0.25 or Higher)
<p>Available as scrolling or fixed display text</p> <ul style="list-style-type: none"> ● Active Shutdowns (if present) ● Active Warnings (if present) ● Genset State ● Average Volts Line-to-Line ● Frequency ● Current ● Average kW ● Coolant Temperature ● Oil Pressure ● Fuel Level % (with diesel-powered models and optional fuel tank sender) ● Fuel Pressure (with gas-powered models and optional sender) ● Battery DC Voltage ● Engine Run Time ● Software Version 	<ul style="list-style-type: none"> ● Total Power kVA (shown as actual output values) ● Total Power kW (shown as actual output values) ● Rated Power ● Volts, L1-L2 * ● Volts, L2-L3 * ● Volts, L3-L1 * ● Volts, L1-N * ● Volts, L2-N * ● Volts, L3-N * ● Current, L1 * ● Current, L2 * ● Current, L3 * ● Frequency ● Reset Calibration (User can reset individual volt and current values or reset all values) 	<ul style="list-style-type: none"> ● System Frequency ● System Phase (Single Phase, Single Phase Doleg, Three Phase Wye, or Three Phase Delta) ● System Volts ● Power Rating ● Amp Rating ● Power Type (Standby or Prime) ● Battery DC Voltage ● Measurement System (Metric or English) * ● Contrast (display) * ● Alarm Silence (Always or Auto Only) 	<ul style="list-style-type: none"> ● Voltage Regulator Voltage Adjust * ● Reset Voltage Regulator Settings * <ul style="list-style-type: none"> ○ Reset Voltage Regulator?
<p>Engine Metering Menu</p> <ul style="list-style-type: none"> ● Engine Speed (Tachometer) ● Oil Pressure ● Coolant Temperature ● Fuel Level (with diesel-powered models and optional fuel tank sender) ● Battery DC Voltage ● Fuel Pressure (with gas-powered models and optional sender) 	<p>GenSet Information Menu</p> <ul style="list-style-type: none"> ● Generator Set Model No. ● Generator Set Serial No. ● Controller Serial No. 	<p>GenSet Calibration Menu (Before Version 3.0.25)</p> <ul style="list-style-type: none"> ● Enter Calibration (Yes or No) * <ul style="list-style-type: none"> ○ Volts, L1-L2 ○ Volts, L2-L3 ○ Volts, L3-L1 ○ Volts, L1-N ○ Volts, L2-N ○ Volts, L3-N ○ Current, L1 ○ Current, L2 ○ Current, L3 ○ Reset Calibration ○ Reset All Calibration (Yes or No) ○ Exit Calibration 	<p>Digital Inputs Menu</p> <ul style="list-style-type: none"> ● DI n A1 ● DI n A2 ● DI n A3 ● DI n B1 (with I/O Board) ● DI n B2 (with I/O Board)
	<p>GenSet Run Time Menu</p> <ul style="list-style-type: none"> ● Engine Run Time ● Engine Loaded ● Engine Starts ● Total Energy kWh 		<p>Digital Outputs Menu</p> <ul style="list-style-type: none"> ● DOut A1 ● DOut B1 (with I/O Board) ● DOut B2 (with I/O Board) ● DOut B3 (with I/O Board) ● DOut B4 (with I/O Board) ● DOut B5 (with I/O Board)
		<p>Voltage Regulator Menu (Before Version 3.0.25)</p> <ul style="list-style-type: none"> ● Enter Voltage Regulator? (Yes or No) * <ul style="list-style-type: none"> ○ Voltage Regulator Adjust ○ Exit Voltage Regulator 	<p>Analog Inputs Menu</p> <ul style="list-style-type: none"> ● AI n A1 (factory reserved and not user programmable) ● AI n A2 ● AI n B1 (with I/O Board) ● AI n B2 (with I/O Board)
			<p>Event Log Menu</p> <ul style="list-style-type: none"> ● See 1.2.4 for a list of items that can appear in Event Log <p>Volt Select Menu (Version 2.8.22 or Higher)</p> <ul style="list-style-type: none"> ● Volt Select: * <ul style="list-style-type: none"> ○ 120/240 V 1 Ph ○ 120/208 V 3 Ph ○ 139/240 V 3 Ph ○ 277/480 V 3 Ph ○ 120/240 V 3 Ph

* User-Defined (changeable) Menu Displays. Use SiteTech™ software to change other settings including User-Defined Menu Displays.

NOTE: Some changes require activating the calibration or adjustment mode. Some displays may only appear when in the calibration or adjustment mode. Refer to Section 2.6 Reviewing Menu Displays to activate the calibration or adjustment mode.

2.5 Monitoring and Programming Setup

The user programmer can access the controller data with the controller digital display or a personal computer (PC) with optional SiteTech™ software to monitor and/or program. Access the controller system with a PC using a USB cable with a mini USB plug. Refer to the Introduction, List of Related Materials for related software literature.

While this manual focuses on data access through the controller pushbutton/rotary selector dial and display, most data entries require input using a PC for initial setup. The PC entries typically include alpha characters such as digital input descriptions.

2.5.1 PC Communications

Communicate between a PC and the generator set controller logic using USB communication protocol. The PC connections require optional SiteTech™ software. Contact your authorized distributor/dealer for assistance.

Local Single Connection

A PC connects to the USB port of the generator set controller using a mini USB connector. See Figure 2-8.

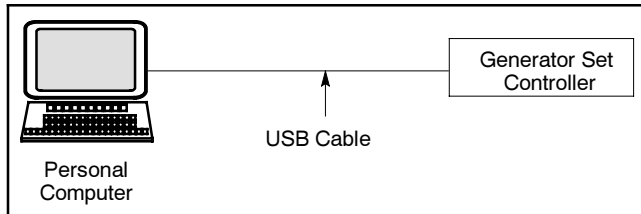

Figure 2-8 Local Single Connection

Remote Single Connection

A modem connects a PC to a single device. The PC communicates with the device via telephone line or an ethernet network. See Figure 2-9.

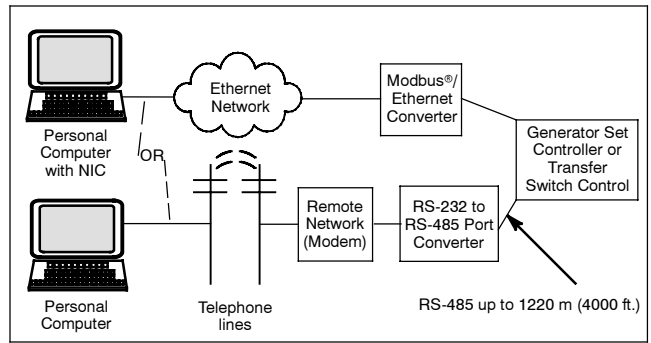
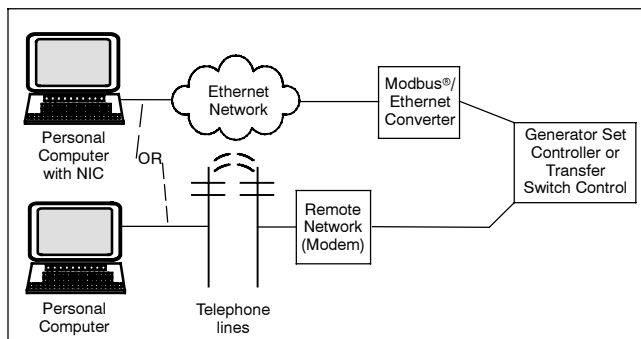

Figure 2-9 Remote Single Connections

2.5.2 Modbus® Communications

The controller communicates using Modbus® as a slave connection with the Modbus® master initiating the communication. The controller seeks the system and alternator parameters and diagnostic information then responds back to the Modbus® master. In addition, the controller accepts information to alter controller parameters including generator set starting and stopping. See Figure 2-10. Refer to the List of Related Materials for available Modbus® literature.

Note: Only one Modbus® master can be connected to the controller. Examples include the remote serial annunciator, Monitor III, and switchgear applications.

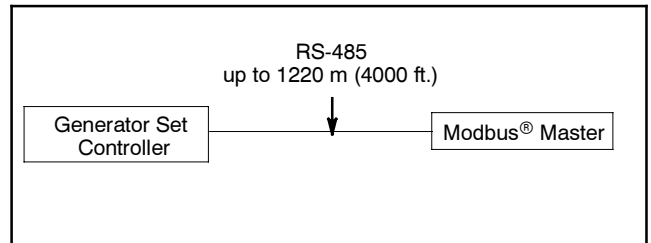

Figure 2-10 Modbus® Connections

Modbus® is a registered trademark of Schneider Electric.

2.6 Reviewing Menu Displays

Use this section to review a summary of the generator set controller data. See Figure 2-11 or Figure 2-12 for which menus provide data monitoring, data adjustments, or require SiteTech™ software to make data adjustments.

Use the pushbutton/rotary selector dial to navigate to the respective menus.

See Section 1, Specifications and Features, to review set point ranges and default settings for comparison to the actual setup.

Menus displaying the # symbol represent one of the following data types:

- System-calculated data
- System-measured data
- User-entered data

Note: The examples given on the following pages represent digital displays with the Measurement System set to English.

2.6.1 Error Messages

Certain entries or attempted entries may cause the controller to display an error message.

Cannot Calibrate appears when attempting to calibrate the voltage and current values in the GenSet Calibration menu with the unit stopped. The unit must be running in order to make adjustments.

Cannot Edit When Stopped appears in the Voltage Regulator menu when attempting to change the VR Volt Adj value when the unit is not running.

Menu Name	Controller Viewable	Controller Adjustable	SiteTech Adjustable
Overview	X		
Engine Metering	X		
Generator Metering	X		
GenSet Information	X		X
GenSet Run Time	X		
GenSet System	X	X	X
GenSet Calibration	X	X	
Voltage Regulation	X	X	X
Digital Inputs	X		X
Digital Outputs	X		X
Analog Inputs	X		X
Event Log	X		

Figure 2-11 Menu Displays for Viewing and Adjusting (Before Firmware Version 3.0.25)

Menu Name	Controller Viewable	Controller Adjustable	SiteTech Adjustable
Overview	X		
Engine Metering	X		
Generator Metering	X	X	
GenSet Information	X		X
GenSet Run Time	X		
GenSet System	X	X	X
Voltage Regulation	X	X	X
Digital Inputs	X		X
Digital Outputs	X		X
Analog Inputs	X		X
Event Log	X		
Volt Select	X	X	X*

* Requires initial activation using SiteTech™

Figure 2-12 Menu Displays for Viewing and Adjusting (Firmware Version 3.0.25 and Higher)

2.6.2 Overview

Displays basic and commonly sought after information about the generator set. This information scrolls automatically after about 5 minutes of no user input (pushbutton/rotary selector dial or button activity).

To change from auto scrolling to fixed display, press the rotary dial and the main menu will appear. Press the rotary dial again to select the first menu item Overview. Turn the rotary dial to select the desired fixed view.

Overview (Auto Scrolling Display)

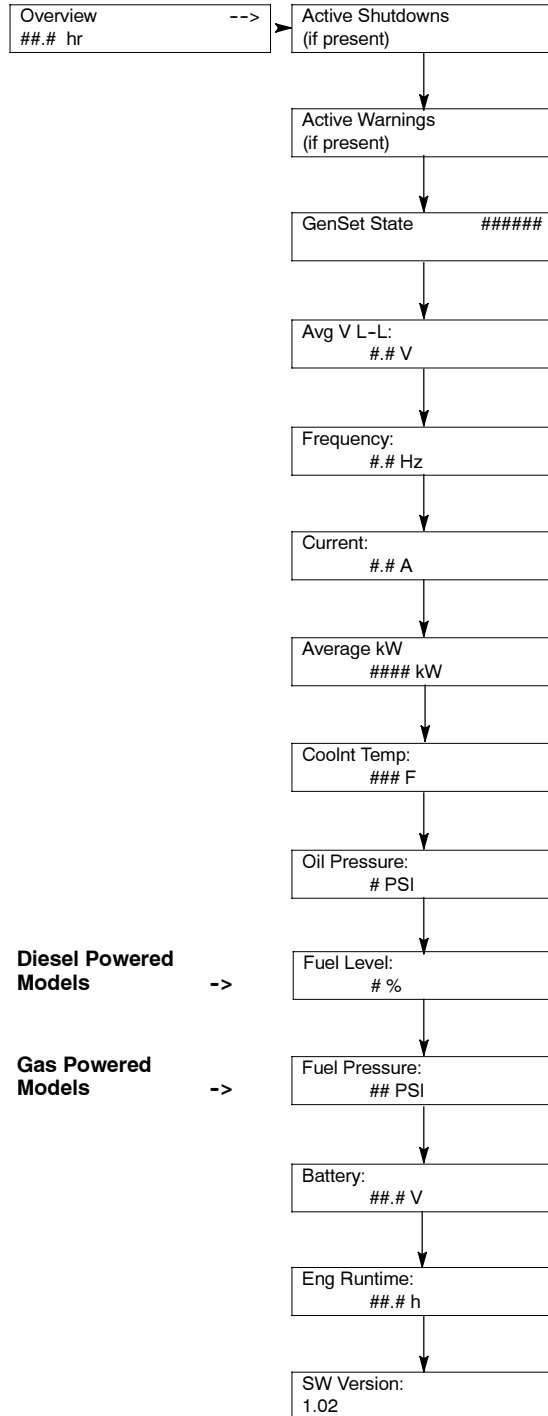

Overview (Fixed Display)

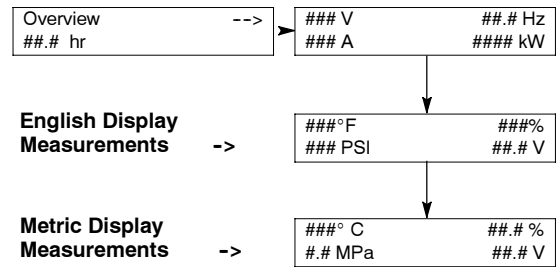

2.6.3 Engine Metering

Displays engine operating data as measured by the engine and other sensors.

Engine Metering

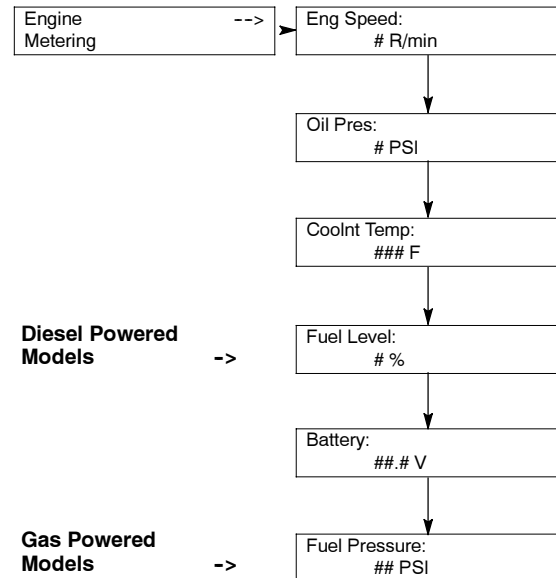

2.6.4 Generator Metering (and Calibration)

Displays generator output data including line-to-line and line-to-neutral voltages, current, frequency, total kilowatts, and total kVA. The menu displays three-phase voltage and current readings when applicable.

All menu displays apply to both single-phase or three-phase voltages on the menu overview. The phase designation does not appear in the controller menu displays. Some displays will show 0 values when single-phase connections are shown.

Firmware Version 3.0.25 and higher:

Display also provides access to the calibration factors for metering (volts and amps). Changing the system voltage or replacing the main logic control circuit board requires calibration adjustment. Connect a meter with a minimum accuracy of 1% to the generator set output leads to calibrate the voltage-sensing logic.

To enable calibration, start the generator set and select the *Volts L1-L2* display. Then push and hold the pushbutton/rotary selector dial until the *Calibration Enabled* popup appears. Calibration of each display is now available. The display will show the following values for three-phase generator sets. Single-phase generator sets will only display items marked (*).

- Volts L1-L2 *
- Volts L2-L3
- Volts L3-L1
- Volts L1-N *
- Volts L2-N *
- Volts L3-N
- Current L1 *
- Current L2 *
- Current L3

The user can change individual values or can select *Reset Calib?*-Yes to reset all voltage and current values. The *Reset Calib?* display will only show if calibration is enabled.

When calibrating voltage, the metered value and the number being entered as the calibrated value must be within 10% of the system operating voltage.

When calibrating current, the metered value must be at least 25% of the rated current on units smaller than 100 kW and at least 50 amps on units rated larger than 100 kW. The number being entered as the calibrated value must within 10% of the metered value.

To disable calibration, Rotate the pushbutton/rotary selector dial until the *<-Return* popup appears.

Momentarily press the pushbutton/rotary selector dial. Stop the generator set if not already done.

Generator Metering

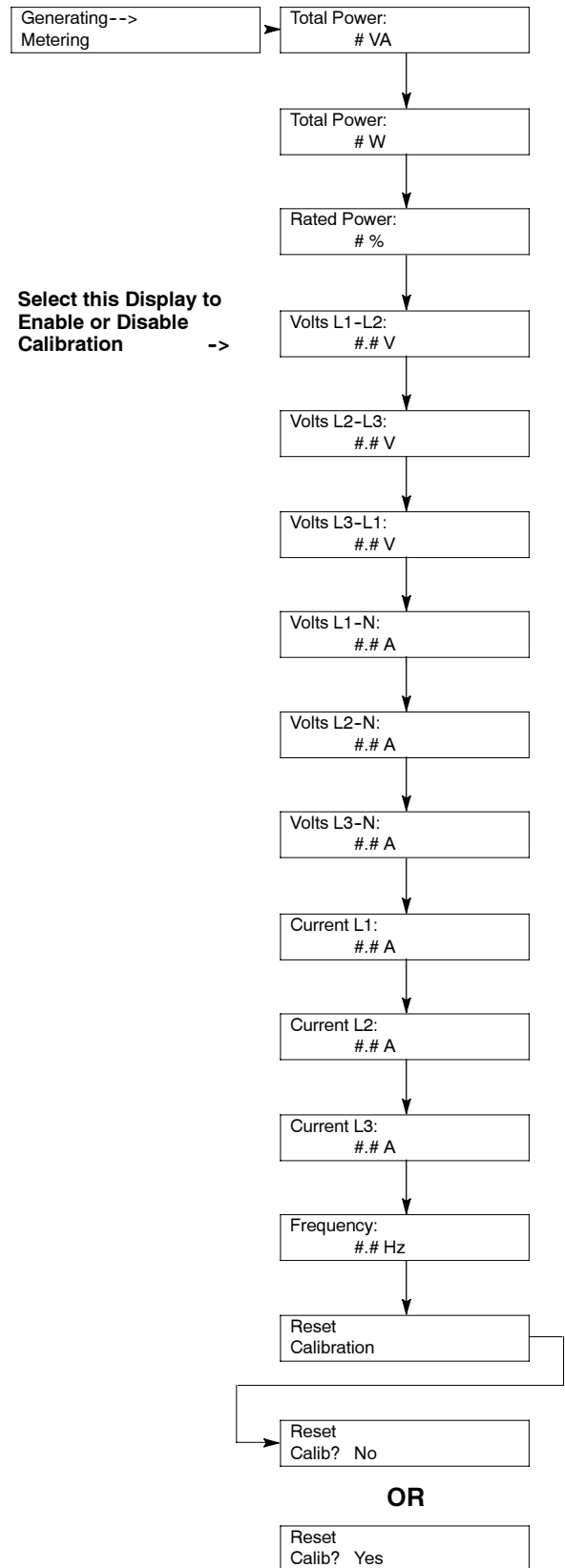

2.6.5 GenSet Information

Displays generator set and controller information. Displayed data is factory entered.

GenSet Information

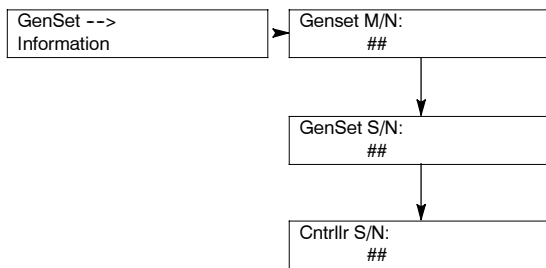

2.6.6 GenSet Run Time

Displays the generator set’s operating record including total run time loaded and unloaded, number of starts, and total energy kW hours.

GenSet Run Time

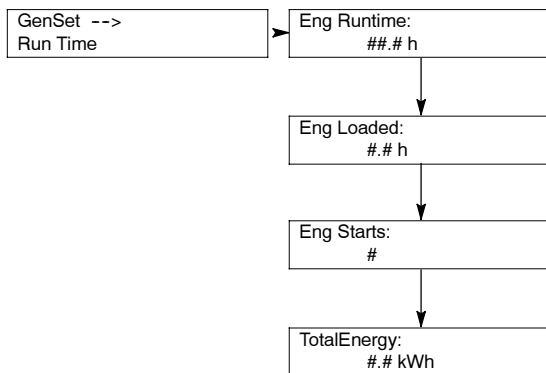

2.6.7 GenSet System

Display shows the generator set system data including voltage, frequency, phase connection, etc. Use the values entered in this menu to help determine shutdown values and time delays.

The programming user defines the data shown in the GenSet System menu. It is NOT data measured by the controller and associated sensing devices. The programming user defines these values for purposes of calibrating the control.

Some alternators are designed to operate at limited voltage, frequency, or phase connections and as a result some settings may have limited parameters.

Display for Measurement System is user selectable as English or Metric.

Contrast display is user adjustable to help improve digital display visibility in dimly lit rooms or in direct sunlight.

Note: The contrast feature is a controller hardware change and may not be available on older units even if the firmware is updated.

Alarm Silence display is programmer selectable to Always or Auto Only using SiteTech™ software. The Always selection activates the alarm horn in any of the OFF/RESET-AUTO-RUN modes. The Auto Only selection activates the alarm horn only when in the Auto mode.

GenSet System

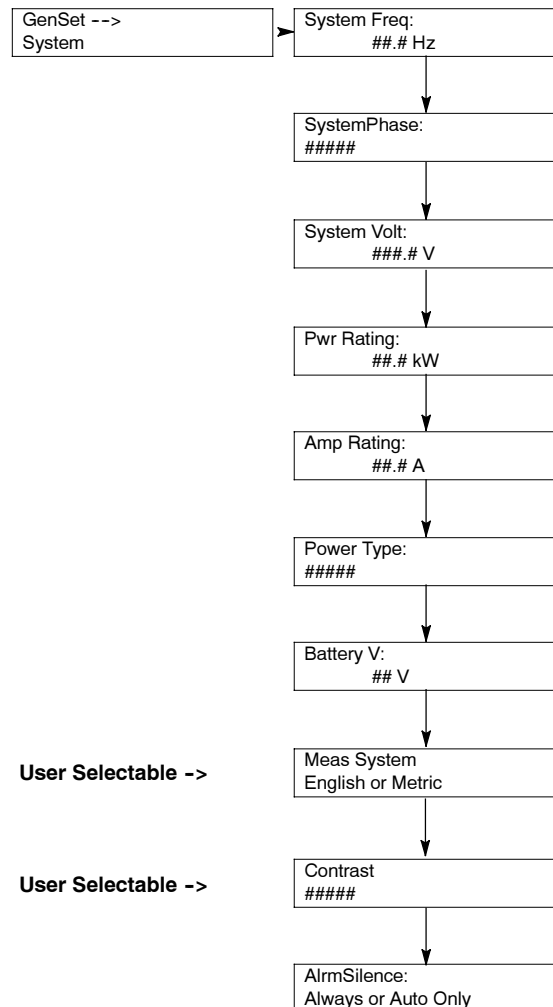

2.6.8 GenSet Calibration

This menu is only available in controller firmware versions before 3.0.25. Go to Generator Metering Menu—Reset Calibration with controller firmware version 3.0.25 or higher.

Display provides access to the calibration factors for metering (volts and amps). Changing the system voltage or replacing the main logic control circuit board requires calibration adjustment. Connect a meter with a minimum accuracy of 1% to the generator set output leads to calibrate the voltage-sensing logic.

The user can individually calibrate the values or reset all of them. The local display Reset all calib? No or Yes. Select No to make no changes and exit GenSet Calibration. Select Yes to reset all of the values.

When calibrating voltage, the metered value and the number being entered as the calibrated value must be within 10% of the system operating voltage.

When calibrating current, the metered value must be at least 25% of the rated current on units smaller than 100 kW and at least 50 amps on units rated larger than 100 kW. The number being entered as the calibrated value must within 10% of the metered value.

GenSet Calibration

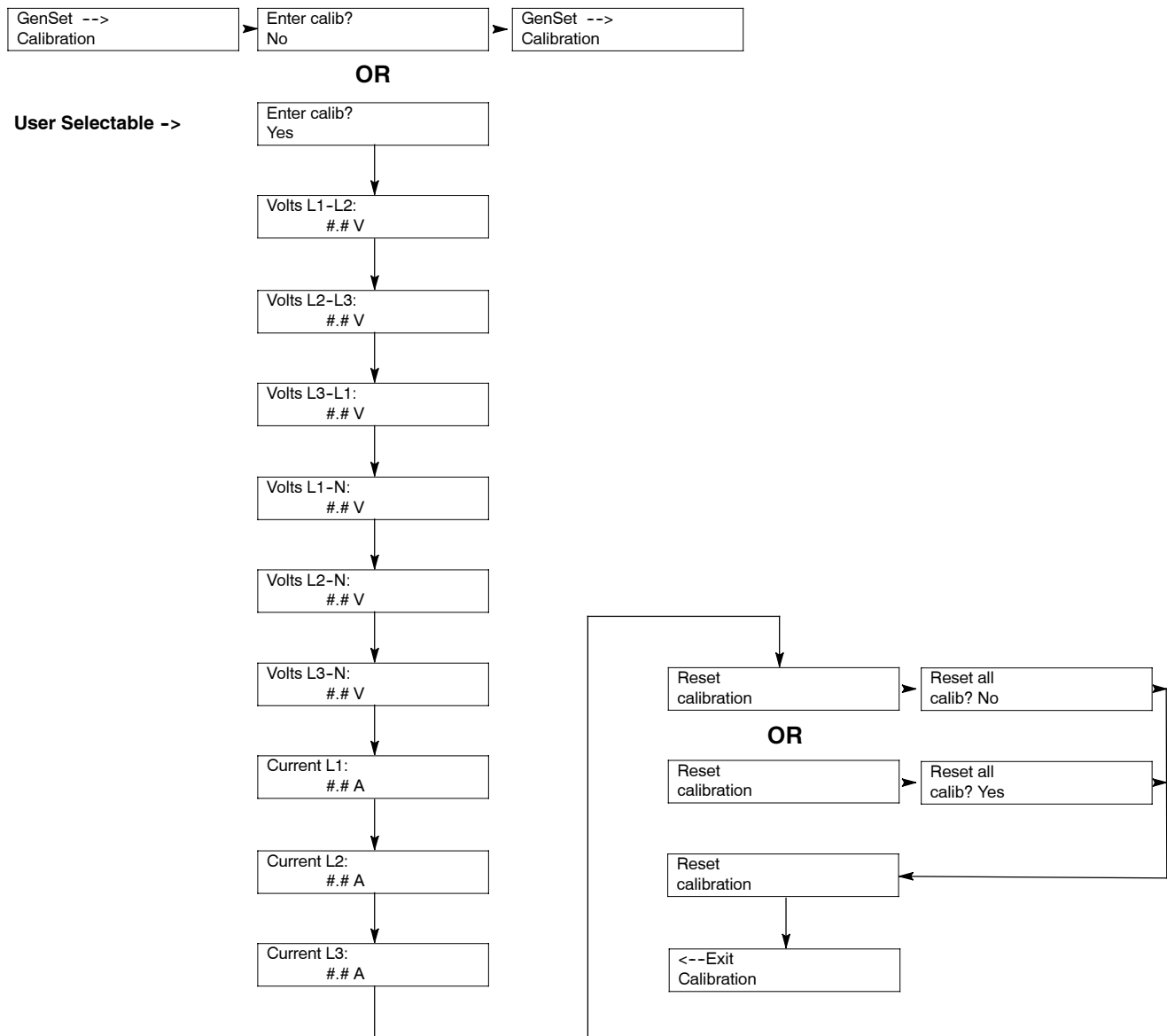

2.6.9 Voltage Regulator

Before Firmware Version 3.0.25.

Displays the voltage regulator adjustment value. All other voltage regulator adjustments are changed using SiteTech™ software.

The voltage regulator value is reviewable at all times. In order to review the value when the generator set is NOT

running, enter Yes when the Enter volt reg? is displayed. The user can review the value but attempting to change the value will cause a Cannot edit when stopped error message.

If the unit is running and Yes is entered when the Enter volt reg? is shown, the display will show the value. The user can change the value at this time.

Voltage Regulator

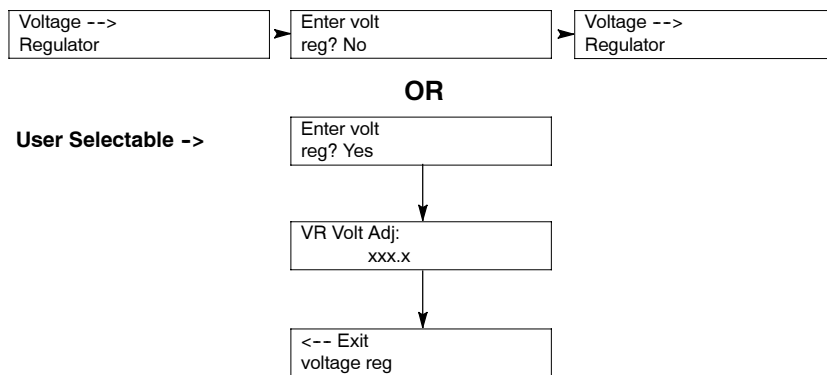

Firmware Version 3.0.25 or Higher.

Displays the voltage regulator adjustment value. All other voltage regulator adjustments are changed using SiteTech™ software.

The voltage regulator value is reviewable at all times and provides the ability to fine adjust voltage. Changing the system voltage or replacing the circuit board typically requires a voltage adjustment.

To enable calibration, start the generator set and select the *VR Volt Adj* display. Then push and hold the

pushbutton/rotary selector dial until the *Editing Enabled* popup appears. Editing of the voltage adjustment is now available.

The user can change the individual value or can select *Reset VR?* - Yes to reset to the default value. The *Reset VR Settings* display will only show if editing is enabled.

To disable calibration, Rotate the pushbutton/rotary selector dial until the *<-Return* popup appears. Momentarily press the pushbutton/rotary selector dial. Stop the generator set if not already done.

Voltage Regulator

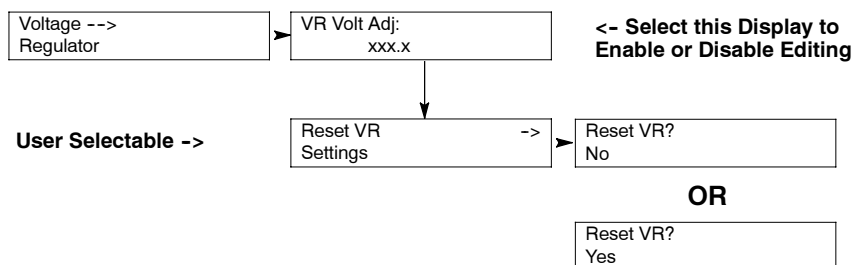

2.6.10 Digital Inputs

Displays the selected programming user-defined digital notice, warning, and shutdown inputs. These inputs provide a multitude of choices for configuring customized auxiliary inputs. See Figure 2-13 for a list of digital input choices. For descriptions of the inputs listed refer to the following:

- 2.3.5 System Fault Warning Lamp with Digital Displays
- 2.3.6 System Fault Shutdown Lamp with Digital Displays
- 2.3.7 Status and Notice Digital Displays

There is an optional 2 input/5 output (I/O) module board available that can provide two additional digital (or analog) inputs.

The displays for digital inputs appear as shown below with Values true or false. Items shown in the display as True are active.

- DIn A1 (digital input A1) standard
- DIn A2 (digital input A2) standard
- DIn A3 (digital input A3) standard
- DIn B1 (digital input B1) with I/O module board
- DIn B2 (digital input B2) with I/O module board

All digital input selection and setup adjustments are done using SiteTech™ software. The following terms and descriptions are part of the setup procedure.

- **Enabled.** This menu indicates whether or not the input is enabled. If the input is not enabled, the controller will ignore this input signal.

- **Inhibit Time Delay.** The inhibit time delay is the time period following crank disconnect during which the generator set stabilizes and the controller does not detect the fault or status event. The controller will ignore the input until the inhibit time expires. If the inhibit time is set to zero, the input is monitored at all times, even when the generator is not running. The inhibit time delay range is from 0 to 60 seconds.

- **Time Delay (shutdown or warning).** The time delay follows the inhibit time delay. The time delay is the time period between when the controller first detects the fault or status event and the controller warning or shutdown lamp illuminates. The delay prevents any nuisance alarms. The time delay range is from 0 to 60 seconds.

Digital Inputs

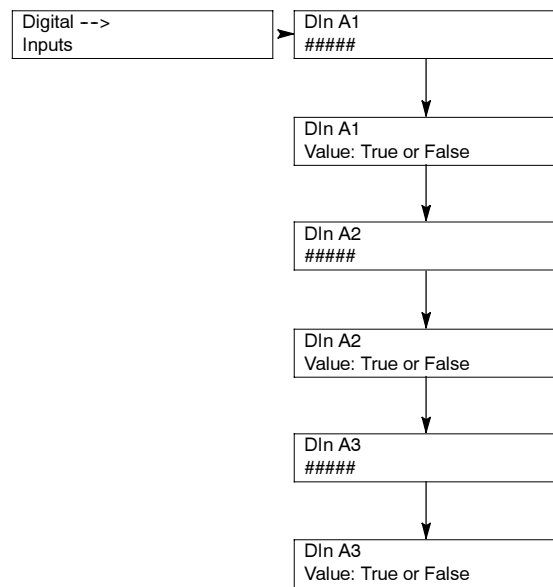

Analog and Digital Inputs	Notice	Warning	Low Warning	High Warning	Critical High Warning	Shutdown	Low Shutdown	High Shutdown
Auxiliary Input		AD				AD		
Battery Charger Fault		AD						
Chicago Code Active	AD							
Engine Fuel Level			AD	D	D		D	
Fuel Tank Leak		AD				D		
Ground Fault		AD						
Low Engine Oil Level			AD				D	
Low Fuel Pressure			AD					

Figure 2-13 Analog and Digital Inputs

2.6.11 Digital Outputs

Displays the selected programming user-defined digital notice, warning, and shutdown outputs. These outputs provide a multitude of choices for configuring customized auxiliary outputs. See Figure 2-14 for a list of digital output choices. For descriptions of the outputs listed refer to the following:

- 2.3.5 System Fault Warning Lamp with Digital Displays
- 2.3.6 System Fault Shutdown Lamp with Digital Displays
- 2.3.7 Status and Notice Digital Displays

There is an optional 2 input/5 output (I/O) module board available that can provide five additional digital outputs.

The displays for digital outputs appear as shown below with Values true or false. Items shown in the display as True are active.

- DOut A1 (digital output A1) standard
- DOut B1 (digital output B1) with I/O module board
- DOut B2 (digital output B2) with I/O module board
- DOut B3 (digital output B3) with I/O module board
- DOut B4 (digital output B4) with I/O module board
- DOut B5 (digital output B5) with I/O module board

Use SiteTech™ software for digital output selection and setup adjustments. Each output is tied to a user-selectable function. The function can be a common fault, common warning, NFPA 110 alarm active, or a specific warning or shutdown.

Digital Outputs

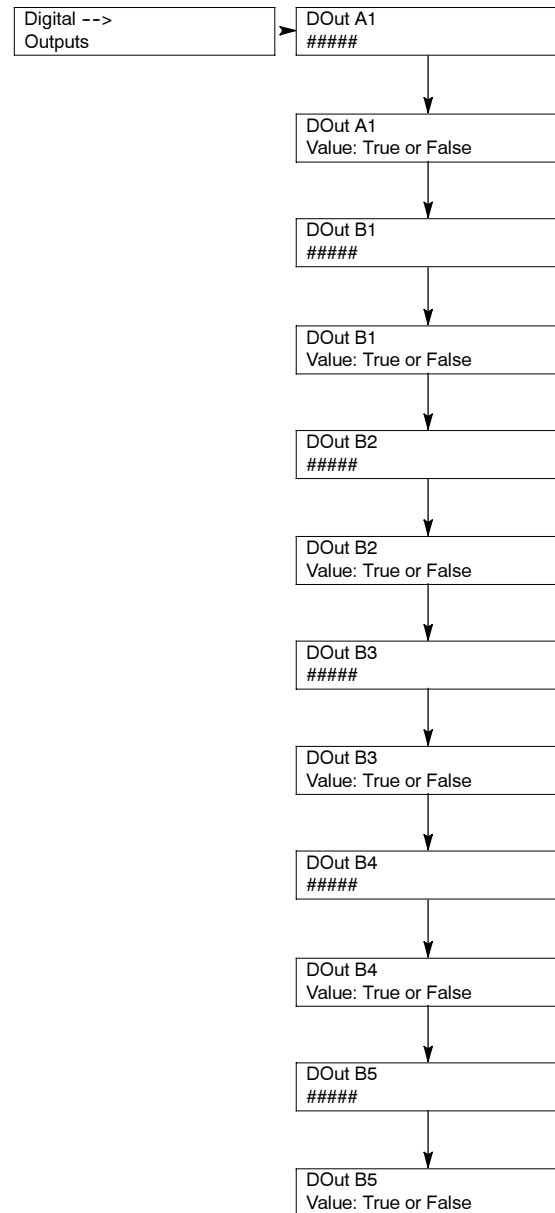

Digital Outputs	Notice	Warning	Low Warning	High Warning	Critical High Warning	Shutdown	No Signal Shutdown	Low Shutdown	High Shutdown
AC Sensing Lost		X				X			
Alternator Protection						X			
Auxiliary Input		X				X			
Battery Charger Fault		X*							
Battery Voltage			X*	X*					
Chicago Code Active	X								
Common Fault	X								
Common Warning	X								
Cranking Voltage			X						
ECM Comm Loss						X			
Emergency Stop						X			
Engine Coolant Level								X*	
Engine Coolant Temperature			X*	X*			X*		X*
Engine Cooldown Active	X								
Engine Fuel Level			X*	X*	X*			X*	
Engine Oil Level			X					X	
Engine Oil Pressure			X*				X*	X*	
Engine Speed								X	X*
Engine Start Aid Active	X								
Engine Start Delay Active	X								
EPS Supplying Load	X								
Fuel Pressure			X*						
Fuel Tank Leak		X				X			
Generator Frequency Average								X	X
Generator Running	X								
Generator True Total Power									X
Generator Voltage L1-L2								X	X
Generator Voltage L2-L3								X	X
Generator Voltage L3-L1								X	X
Ground Fault		X							
Locked Rotor						X			
NFPA 110 Alarm Active	X								
Not In Auto		X*							
Overcrank						X*			
Speed Sensor Fault		X							
System Ready	X								

* NFPA 110 Defined Common Alarms

Figure 2-14 Digital Outputs with NFPA 110 Defined Common Alarms

2.6.12 Analog Inputs

Displays the selected programming user-defined analog notice, warning, and shutdown inputs. These inputs provide a multitude of choices for configuring customized auxiliary inputs. See Figure 2-13 for a list of analog input choices. For descriptions of the inputs listed refer to the following:

- 2.3.5 System Fault Warning Lamp with Digital Displays
- 2.3.6 System Fault Shutdown Lamp with Digital Displays
- 2.3.7 Status and Notice Digital Displays

There is an optional 2 input/5 output (I/O) module board available that can provide two additional analog (or digital) inputs.

The displays for analog inputs appear as shown below and have an acceptable operating range (0-5 VDC). The analog input selection typically requires entering four values—low warning, high warning, low shutdown, and high shutdown.

- AIn A1 (analog input A1) standard (reserved and not user programmable)
- AIn A2 (analog input A2) standard (Identified as A1 on SiteTech™ software)
- AIn B1 (analog input B1) with I/O module board
- AIn B2 (analog input B2) with I/O module board

All analog input selection and setup adjustments are done using SiteTech™ software. The following terms and descriptions are part of the setup procedure.

- **Enabled.** This menu indicates whether or not the input is enabled. If the input is not enabled, the controller will ignore this input signal.
- **Inhibit Time Delay.** The inhibit time delay is the time period following crank disconnect during which the generator set stabilizes and the controller does not detect the fault or status event. The controller will ignore the input until the inhibit time expires. If the inhibit time is set to zero, the input is monitored at all times, even when the generator is not running. The inhibit time delay range is from 0 to 60 seconds.
- **Time Delay (shutdown or warning).** The time delay follows the inhibit time delay. The time delay is the time period between when the controller first detects the fault or status event and the controller warning or shutdown lamp illuminates. The delay prevents any nuisance alarms. The time delay range is from 0 to 60 seconds.

Analog Inputs

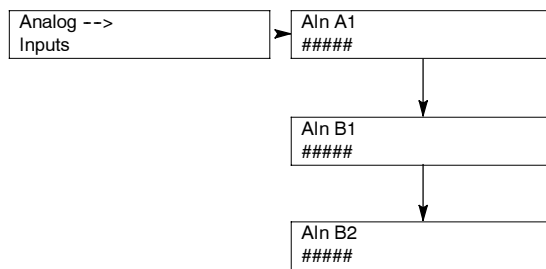

2.6.13 Event Log

Displays up to 1000 stored status, warning, and shutdown events. After the first 1000 events, each additional new event replaces the oldest event. See 1.2.4 Controller Fault Diagnostics for a list of possible events.

Event Log

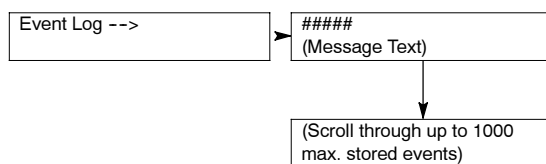

2.6.14 Volt Select

This menu is only available in controller firmware version 2.8.22 and higher.

This menu allows the user to readily change controller voltage settings. The volt select feature is typically used in towable or temporary applications.

Note: The volt select menu requires initial activation by SiteTech™ software. In SiteTech™ software, select True to activate the volt select menu.

Note: The generator set output leads require voltage reconnection if the generator set does not have a voltage selector switch installed.

With the generator set stopped, go to the Volt Select menu. Then push and hold the pushbutton/rotary selector dial until the voltage selection starts to flash. Volt selection is now available. Scroll to the desired voltage and momentarily press the pushbutton/rotary selector dial to confirm the voltage selection.

Volt Select

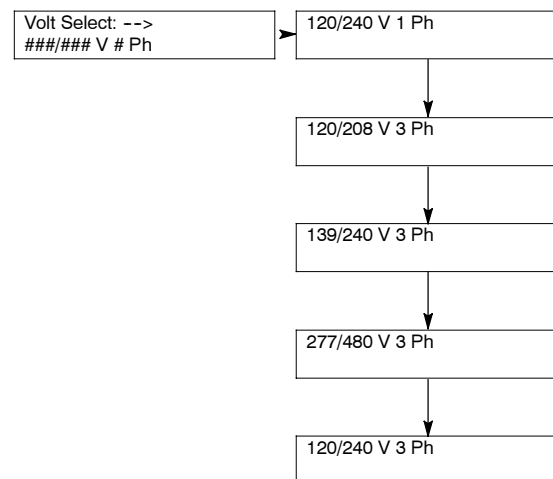

Section 3 Scheduled Maintenance

Under normal operating conditions, the generator set's alternator requires no routine service. Consult Section 2.1, Prestart Checklist, for a list of routine checks.

3.1 Alternator Service

When operating the generator set under dusty or dirty conditions, use dry compressed air to blow dust out of the alternator while the generator set is running. Direct the stream of air through openings in the generator set end bracket.

3.2 Engine Service

Perform engine service at the intervals specified in the engine manufacturer's service literature. Contact an authorized service distributor/dealer to obtain service literature.

Note: Have maintenance work, including battery service, performed by appropriately skilled and suitably trained maintenance personnel familiar with generator set operation and service.

⚠ WARNING

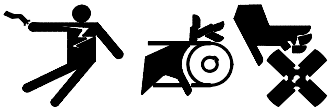

Accidental starting. Can cause severe injury or death.

Disconnect the battery cables before working on the generator set. Remove the negative (-) lead first when disconnecting the battery. Reconnect the negative (-) lead last when reconnecting the battery.

Disabling the generator set. Accidental starting can cause severe injury or death. Before working on the generator set or connected equipment, disable the generator set as follows: (1) Move the generator set master switch to the OFF position. (2) Disconnect the power to the battery charger. (3) Remove the battery cables, negative (-) lead first. Reconnect the negative (-) lead last when reconnecting the battery. Follow these precautions to prevent starting of the generator set by an automatic transfer switch, remote start/stop switch, or engine start command from a remote computer.

⚠ WARNING



Hot engine and exhaust system. Can cause severe injury or death.

Do not work on the generator set until it cools.

Servicing the exhaust system. Hot parts can cause severe injury or death. Do not touch hot engine parts. The engine and exhaust system components become extremely hot during operation.

⚠ WARNING



Hazardous voltage. Moving parts. Can cause severe injury or death.

Operate the generator set only when all guards and electrical enclosures are in place.

Servicing the generator set when it is operating. Exposed moving parts can cause severe injury or death. Keep hands, feet, hair, clothing, and test leads away from the belts and pulleys when the generator set is running. Replace guards, screens, and covers before operating the generator set.

3.3 Service Schedule

System—Component	Action					Interval
	Visually Inspect	Check	Change	Clean	Test	
Fuel System						
Day tank level	X	X				Weekly
Flexible lines and connections	X		R			Weekly
Fuel level switch	X				X	Weekly
Main tank supply level		X				Weekly
Solenoid valve operation	X				X	Weekly
Transfer pump operation	X				X	Weekly
Water in system, remove		•		•		Weekly
Filter(s)			•			Quarterly
Gasoline supply			R			Six Months
Fuel piping	X					Yearly
Tank vents and return lines for obstructions		X				Yearly
Lubrication System						
Oil level	•	•				Weekly
Crankcase breather	•		•			Quarterly
Change oil			•			First 50 Hrs., Then Every 250 Hrs.
Replace filter(s)*			•			
Cooling System						
Air cleaner to room/enclosure		X				Weekly
Block heater operation		X				Weekly
Coolant level	•	•				Weekly
Flexible hoses and connectors	X	X				Weekly
Water pump(s)	•					Weekly
Fan and alternator belts	•	•	R			Monthly
Coolant temperature protection level					•	Six Months
Air ducts, louvers		X		X		Yearly
Coolant			•			Yearly
Heat exchanger				X		Yearly
Louver motors and controls	X			X	X	Yearly
Radiator exterior				X		Yearly
Water supply to heat exchanger		X				Yearly
Exhaust System						
Drain condensate trap		X				Weekly
Leakage	X	X				Weekly
Insulation, fire hazards	X					Quarterly
Flexible connector(s)	X					Six Months
Excessive back pressure					X	Yearly
Hangers and supports	X					Yearly
DC Electrical System						
Battery charger operation, charge rate	X					Monthly
Battery electrolyte level		X				Monthly
Battery specific gravity, charge state					X	Monthly
Recharge after engine start		X				Monthly
Remove corrosion, clean and dry battery and rack	X			X		Monthly
Clean and tighten battery terminals	X	X				Quarterly
Tighten DC electrical connections		X				Six Months
<ul style="list-style-type: none"> • Follow procedures and frequencies indicated in the engine manufacturer's maintenance manual. If not indicated, follow this service schedule. Some items may not apply to all generator sets. R Replace as necessary. X Action * Service more frequently if operated in dusty areas. 						

Service Schedule, continued

System—Component	Action					Interval
	Visually Inspect	Check	Change	Clean	Test	
AC Electrical System						
Controller lamp test	X				R	Weekly
General Inspection	X					Weekly
Circuit breakers, fuses†	X	X	R	X	X	Monthly
Wire abrasions where subject to motion	X	X				Quarterly
Safety and alarm operation		X			X	Six Months
Tighten control and power wiring connections		X				Yearly
Transfer switch main contacts†	X			X		Yearly
Voltage-sensing device/relay adjustment†		•			•	Yearly
Wire-cable insulation breakdown	X				X	3 Years or 500 Hrs.
Engine and Mounting						
General inspection	•					Weekly
Governor operation, lubricate moving parts	•	•				Monthly
Air cleaner service		•	•			Six Months
Choke, carburetor adjustment		•				Six Months
Governor oil (mechanical governor only)		•				Yearly
Ignition components	•			•		Yearly
Injector pump and injector flow rate, pressure, spray pattern		•			•	Yearly
Valve clearance		•				3 Years or 500 Hrs.
Bolt torque		•			•	3 Years or 500 Hrs.
Remote Control System, etc.						
Compartment condition	X			X		Weekly
Remote control					X	Monthly
Run generator set					X	Monthly
Alternator						
General inspection	X					Weekly
Rotor and stator	X			X		Yearly
Bearing condition	X	X	R			Yearly
Exciter	X	X		X		Yearly
Voltage regulator	X	X		X		Yearly
Measure and record resistance readings of windings with insulation tester (Megger®, with SCR assembly or rectifier disconnected)					X	Yearly
Blow dust out of alternator*	X			•		2 Years or 300 Hrs.
General Condition of Equipment						
Any condition of vibration, leakage, noise, temperature, or deterioration	X	X		X		Weekly
Ensure that system is set for automatic operation	X					Weekly
Interior of equipment room or outdoor weather housing	X			X		Weekly
<ul style="list-style-type: none"> • Follow procedures and frequencies indicated in the engine manufacturer's maintenance manual. If not indicated, follow this service schedule. Some items may not apply to all generator sets. R Replace as necessary. X Action. * Service more frequently if operated in dusty areas. † Do not break manufacturer's seals or internally inspect these devices. 						

Megger® is a registered trademark of Biddle Instruments.

3.4 Alternator Bearing Service

Have an authorized service distributor/dealer perform service.

3.4.1 20–300 kW Models

Replace the end bracket bearing every 10,000 hours of operation in prime power applications. Service the bearing more frequently if the annual inspection indicates excessive rotor end play or bearing damage. The sealed end bracket bearing requires no additional lubrication.

3.4.2 300–1000 kW Models with 4M/5M/7M Single-Bearing Alternator

The alternator bearing requires lubrication at intervals specified in the generator set technical manual. Use Chevron SRI or equivalent antifriction, high-quality grease with a lubrication temperature range of -30°C to 175°C (-22°F to 350°F).

3.5 Diesel Fuel Systems

3.5.1 Bleeding Air from Fuel System

Bleed air from the fuel system after fuel system maintenance, such as replacing the fuel filter(s). Use the hand prime pump kit, when equipped. The hand prime fuel pump eliminates the need for cranking the engine to bleed air from the fuel system.

Note: Bleed air from the fuel system according to the engine manufacturer's instructions. Trapped air in the fuel system causes difficult starting and/or erratic engine operation.

Note: Correct any fuel leaks encountered during the priming procedure.

1. Place the fuel valves in the fuel system prime position. Close the fuel valve located between the pipe tee and the engine. Open the fuel valves on each side of the fuel prime pump. See Figure 3-1.

Note: The illustration shows a generator set without a fuel/water separator. The valve location and position for a generator set equipped with a fuel/water separator is similar.

2. Loosen the bleed screw at the engine. Refer to the engine operation manual for location of the bleed screw(s). The bleed screw allows air to be expelled from the fuel system when the hand prime pump is operated.

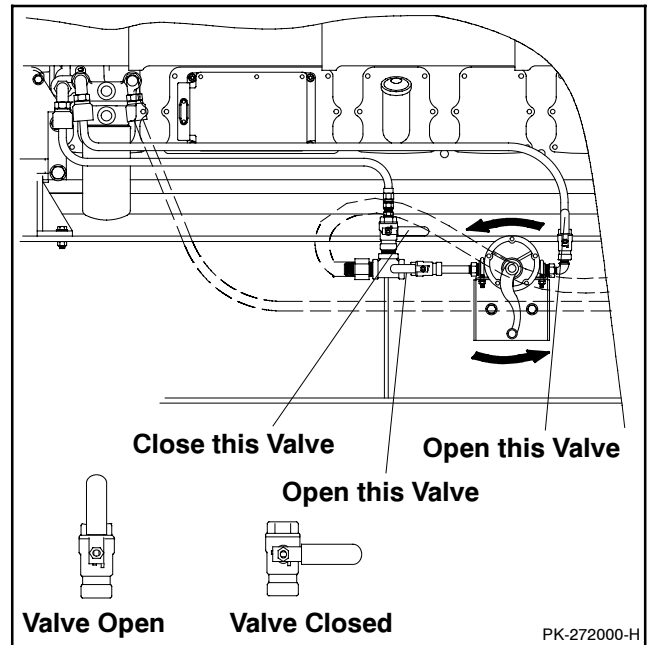

Figure 3-1 Hand Prime Pump with Valve Positions for Fuel Priming (generator set without a fuel/water separator shown), Typical

3. Rotate the hand prime pump handle counterclockwise until fuel flows from the bleed screw. Stop pumping.
4. Tighten the bleed screw. Wipe up any fuel leakage.
5. Place the fuel valves in the normal operation position. Open the fuel valve located between the pipe tee and the engine. Close the fuel valves on each side of the fuel prime pump.

3.6 Gas Fuel Systems

Gas fuel systems apply to REZG_/RZG_/ERES_ (GM Powered) and REZX_/RZX_ (Doosan Powered) generator set models.

This section describes natural gas and liquified petroleum gas (LPG) fuel systems that are not covered in the engine operation manual or engine service manual.

3.6.1 Gas Fuel System Concept (Single Fuel)

The gas fuel system uses a fuel valve with a solenoid to control the fuel flow to the fuel regulator. The generator set-mounted regulator reduces the fuel pressure as fuel passes to the fuel mixer. See Figure 3-2.

The fuel mixer controls the ratio of fuel to air under varying load and speed conditions. Because the fuel mixer receives fuel in a gaseous state, it does not have to vaporize the fuel.

3.6.2 LPG Liquid Withdrawal Fuel System Concept

With the LPG liquid withdrawal fuel system, pressurized liquid LPG fuel passes from the tank to a vaporizer. The vaporizer converts the liquid fuel to gas before sending it to the fuel mixer. The system also includes a fuel valve that shuts off the fuel flow when the engine stops. Contact an authorized service distributor/dealer for availability.

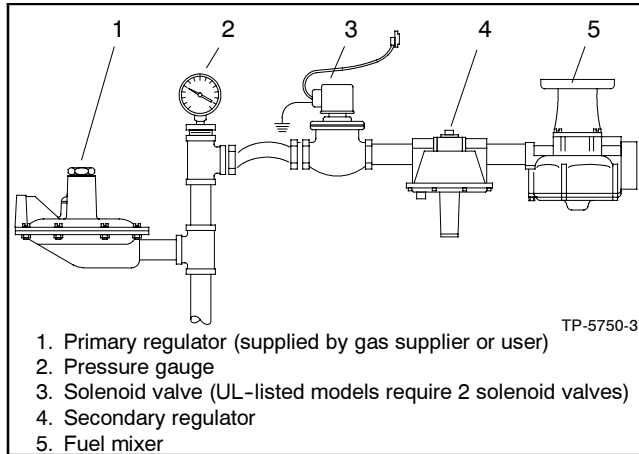

Figure 3-2 Fuel Regulator and Valve, Typical

3.6.3 Natural Gas and LPG Conversion

Most models operate on either natural gas or LPG fuel by performing the fuel conversion procedure. A hang tag on the fuel regulator may provide additional conversion setup information. Fuel conversion may decrease generator set output. Refer to the respective generator set spec sheet for ratings based on fuel selection. Changing fuel does not alter the emissions compliance of the generator set engine. Consult your local generator set distributor/dealer for additional information.

Note: If a gas-fueled model has the fuel type changed (LPG to natural gas or natural gas to LPG), order a new nameplate from an authorized distributor/dealer with the updated ratings and attach to the generator set.

To change the fuel type, change the electrical connections to the engine ECM. The engine ECM has fuel tables and spark advance curves programmed for both natural gas and LPG. The information following, in Figure 3-3, and in Figure 3-4 generally apply to all models and all fuels. Be sure to review the respective wiring diagram for your specific model for possible special applications.

Natural Gas Operation

- Disconnect lead 65 from lead N5.
- Disconnect lead 73B from the fuel valve.
- Connect lead 73A to the fuel valve.

LPG Vapor Operation

- Disconnect lead 73A from the fuel valve.
- Connect lead 73B to the fuel valve (LPG vapor).
- Connect lead 65 to lead N5 (ground).

LPG Liquid Withdrawal Operation

- Disconnect lead 73A from the fuel valve.
- Connect lead 73B to the fuel valve (LPG liquid withdrawal).
- Connect lead 65 to lead N5 (ground).

Auto Changeover Natural Gas/LPG Vapor Operation

- Disconnect lead 65 from N5.
- Connect lead N5 to LFP2 relay common terminal.
- Connect lead 73A to the fuel valve (natural gas).
- Connect lead 73B to the fuel valve (LPG vapor).

Eng. ECM	Natural Gas	LPG Vapor	LPG Liquid	Auto Changeover
73A	QCON-7 (NG fuel valve)	not used		QCON-7 (NG fuel valve)
N5	not used	65	65	LFP2-COM
73B	not used	QCON-10 (LPG fuel valve)		
65	not used	N5	N5	not used
63	LFP1-NC low fuel pressure sensor (if used)			
70E2	P6-B (15 amp fuse)			

Figure 3-3 Gas Fuel Electrical Connections

3.6.4 Fuel System Changeover Kits (Dual Fuel)

Automatic Changeover

A changeover fuel system kit provides automatic changeover from natural gas to LPG vapor. The primary and backup fuels each have a fuel valve. The primary fuel is natural gas; the backup fuel is LPG vapor. Before starting, both fuel valves are closed. When the generator set starts, the primary fuel valve opens. The primary fuel line has a pressure switch in series with a relay connected to the start/run circuit.

When the primary fuel pressure drops below 0.6 kPa (1.4 oz./in.²) or 6.4 cm (2.5 in.) water column, a relay opens the backup fuel valve and closes the primary fuel valve. When the primary fuel pressure rises above 0.6 kPa (1.4 oz./in.²) or 6.4 cm (2.5 in.) water column, the generator set uses the primary fuel. Contact an authorized service distributor/dealer for kit availability.

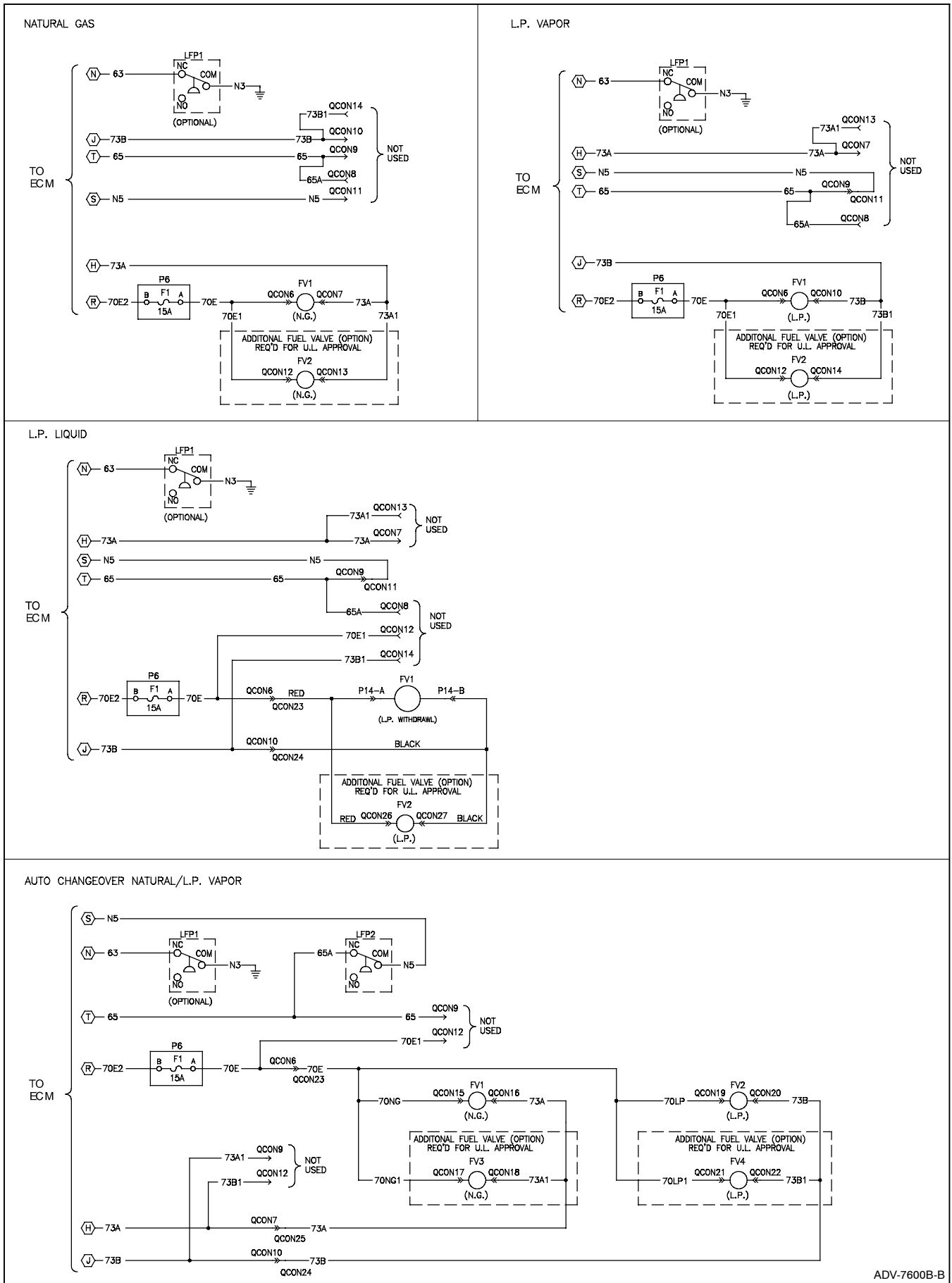

ADV-7600B-B

Figure 3-4 Gas Fuel Connections Wiring Diagram

Emissions certified models use a single electronic-controlled pressure regulator (EPR) for both fuels. A tee fitting connects both fuels together upstream of the EPR. During operation when using the secondary fuel, it is normal for a small amount of secondary fuel to seep back through the primary fuel valve. To counter this situation, one of two methods is used depending upon the generator set model: (1) a second valve (identical to the primary fuel valve) is installed in a reverse configuration on the primary fuel side or (2) a small vent line is installed between the primary fuel inlet and the air intake through a solenoid valve.

3.7 Crankcase Ventilation (CCV) Heater Kit GM78171-KP1

Applies to 125/150REZG_ (GM Powered) generator set models. Consult your local generator set distributor/dealer for additional information.

The crankcase ventilation (CCV) heater kit provides a controlled heating source to the crankcase ventilation system preventing freezing water buildup during cold weather. The thermostat turns on at 4°C (40°F) and turns off at 16°C (60°F) reducing energy consumption. See Figure 3-5.

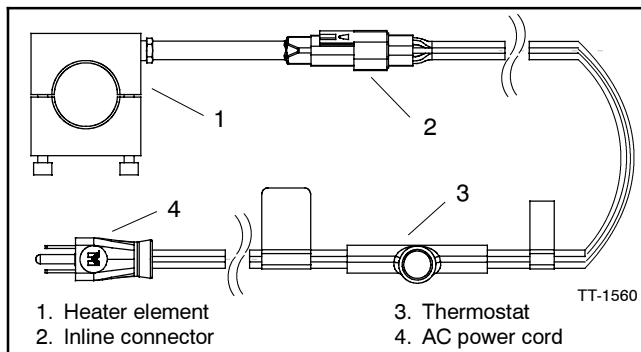



Figure 3-5 Crankcase Ventilation Heater Kit

3.8 Cooling System

The cooling system maintenance information applies to radiator-cooled models which have a radiator with a pressure cap and coolant recovery tank.

 WARNING

<p>Hot coolant and steam. Can cause severe injury or death.</p> <p>Before removing the pressure cap, stop the generator set and allow it to cool. Then loosen the pressure cap to relieve pressure.</p>

Allow the engine to cool. Release pressure from the cooling system before removing the pressure cap. To release pressure, cover the pressure cap with a thick cloth and then slowly turn the cap counterclockwise to the first stop. Remove the cap after pressure has been completely released and the engine has cooled. Check the coolant level at the tank if the generator set has a coolant recovery tank.

Note: Engine damage. Bleed the air from the cooling system to prevent overheating and subsequent engine damage.

Note: Block heater damage. The block heater will fail if the energized heater element is not immersed in coolant. Fill the cooling system before turning on the block heater. Run the engine until it is warm, and refill the radiator to purge the air from the system before energizing the block heater.

3.8.1 Coolant Level Check

Check the coolant level in the coolant recovery tank. Maintain the coolant level between the high and low marks.

Note: Periodically check the coolant level by removing the pressure cap. Do not rely solely on the level in the coolant recovery tank. Add fresh coolant until the level is just below the overflow tube opening of the filler neck.

3.8.2 Cooling System Component Inspection

To prevent generator set shutdown or damage caused by overheating:

- Keep the cooling air inlets clean and unobstructed.
- Inspect the radiator's exterior for obstructions. Remove dirt and foreign material using a soft brush or cloth to avoid damaging the radiator fins.
- Check the hoses and connections for leaks. Replace any cracked, frayed, or spongy hoses.
- Check the condition and tension of the radiator fan and water pump belt(s). Follow the belt tension procedure in this manual and/or the engine operation manual.
- Check the pressure cap seal and replace a cracked or deteriorated cap. Remove dirt and other debris from the pressure cap and filler neck. The pressure cap raises the boiling point of the coolant, enabling higher operating temperatures. Replace a leaking pressure cap with one rated for the same pressure. The pressure cap rating usually appears on the pressure cap.

3.8.3 Procedure to Drain Cooling System

For optimum protection, drain, flush, and refill the cooling system at the intervals listed in the service schedule.

Note: Dispose of all waste materials (oil, fuel, coolant, filters, and gaskets) in an environmentally safe manner.

1. Deenergize the block heater, if equipped.
2. Remove the pressure cap to allow the entire system to drain and prevent air pockets from restricting coolant flow through the engine block.
3. Open the radiator and/or engine block coolant drain valve(s) and allow the system to drain.
4. If the inside of the radiator has mineral deposits or the used coolant contains dirt or grease, refer to Section 3.8.4, Procedure to Flush and Clean the Cooling System. If the cooling system does not have mineral deposits, go to Section 3.8.5, Procedure to Refill the Cooling System.

3.8.4 Procedure to Flush and Clean Cooling System

Use the instructions in the engine operation manual when available to flush and clean the cooling system. Otherwise, use the following procedure and the cooling system cleaner manufacturer's instructions.

1. Flush the cooling system with clean water.
2. If the inside of the radiator still has mineral deposits, use a radiator cleaner to remove the remaining deposits following the manufacturer's instructions.
3. Drain, clean, and flush the coolant recovery tank.

3.8.5 Procedure to Refill Cooling System

See the generator set spec sheet for coolant capacity.

Note: Do not add coolant to a hot engine. Adding coolant to a hot engine can cause the cylinder block or cylinder head to crack. Wait until the engine has cooled.

1. Remove the pressure cap.
2. Close the radiator and/or engine block coolant drain valve(s) and tighten the cooling system hose clamps.

3. Open the air-bleed petcocks, if equipped. Close the air-bleed petcocks when coolant begins to flow from them.
4. Add coolant additives or water pump lubricants according to the engine manufacturer's recommendations in the engine operation manual.
5. Fill the cooling system with the recommended coolant/antifreeze mixture of 50% ethylene glycol and 50% clean, softened water to inhibit rust/corrosion and prevent freezing.

A coolant solution of 50% ethylene glycol provides freezing protection to -37°C (-34°F) and overheating protection to 129°C (265°F). A coolant solution containing less than 50% ethylene glycol may not provide adequate freezing and overheating protection. A coolant solution containing more than 50% ethylene glycol can cause engine or component damage. Do not use alcohol or methanol antifreeze or mix them with the specified coolant. Refer to the engine operation manual for recommendations regarding the coolant mixture to use in extreme temperatures.

6. Replace the pressure cap.
7. Fill the coolant recovery tank to the low mark.
8. Operate generator set until the thermostat opens when the upper cooling system hose warms.
9. Stop the engine and allow it to cool.
10. Check and repair any coolant leaks.
11. Remove the pressure cap.
12. Add coolant to bring the coolant level to just below the overflow tube opening of the filler neck.
13. Replace the pressure cap.
14. Maintain the coolant level in the coolant recovery tank between the high and low marks.

Air pockets often form in the engine water jacket when the coolant system is refilled. Check the coolant level in the coolant recovery tank after each generator set operation and add coolant as necessary until the coolant level stabilizes. Then check the coolant at the interval specified in the service schedule.
15. Reenergize the block heater, if equipped.

3.9 Battery

⚠ WARNING



**Sulfuric acid in batteries.
Can cause severe injury or death.**

Wear protective goggles and clothing. Battery acid may cause blindness and burn skin.

Battery electrolyte is a diluted sulfuric acid. Battery acid can cause severe injury or death. Battery acid can cause blindness and burn skin. Always wear splashproof safety goggles, rubber gloves, and boots when servicing the battery. Do not open a sealed battery or mutilate the battery case. If battery acid splashes in the eyes or on the skin, immediately flush the affected area for 15 minutes with large quantities of clean water. Seek immediate medical aid in the case of eye contact. Never add acid to a battery after placing the battery in service, as this may result in hazardous spattering of battery acid.

Battery acid cleanup. Battery acid can cause severe injury or death. Battery acid is electrically conductive and corrosive. Add 500 g (1 lb.) of bicarbonate of soda (baking soda) to a container with 4 L (1 gal.) of water and mix the neutralizing solution. Pour the neutralizing solution on the spilled battery acid and continue to add the neutralizing solution to the spilled battery acid until all evidence of a chemical reaction (foaming) has ceased. Flush the resulting liquid with water and dry the area.

Battery gases. Explosion can cause severe injury or death. Battery gases can cause an explosion. Do not smoke or permit flames or sparks to occur near a battery at any time, particularly when it is charging. Do not dispose of a battery in a fire. To prevent burns and sparks that could cause an explosion, avoid touching the battery terminals with tools or other metal objects. Remove all jewelry before servicing the equipment. Discharge static electricity from your body before touching batteries by first touching a grounded metal surface away from the battery. To avoid sparks, do not disturb the battery charger connections while the battery is charging. Always turn the battery charger off before disconnecting the battery connections. Ventilate the compartments containing batteries to prevent accumulation of explosive gases.

Battery short circuits. Explosion can cause severe injury or death. Short circuits can cause bodily injury and/or equipment damage. Disconnect the battery before generator set installation or maintenance. Remove all jewelry before servicing the equipment. Use tools with insulated handles. Remove the negative (-) lead first when disconnecting the battery. Reconnect the negative (-) lead last when reconnecting the battery. Never connect the negative (-) battery cable to the positive (+) connection terminal of the starter solenoid. Do not test the battery condition by shorting the terminals together.

Refer to this section for general battery information and maintenance. All generator set models use a negative ground with a 12-volt or 24-volt engine electrical system. Consult the generator set nameplate for the engine electrical system voltage. Consult the generator set spec sheet for battery capacity recommendations for replacement purposes. The wiring diagrams provide battery connection information. See Figure 3-6, Figure 3-7, and Figure 3-8 for typical battery connections, including multiple battery configurations.

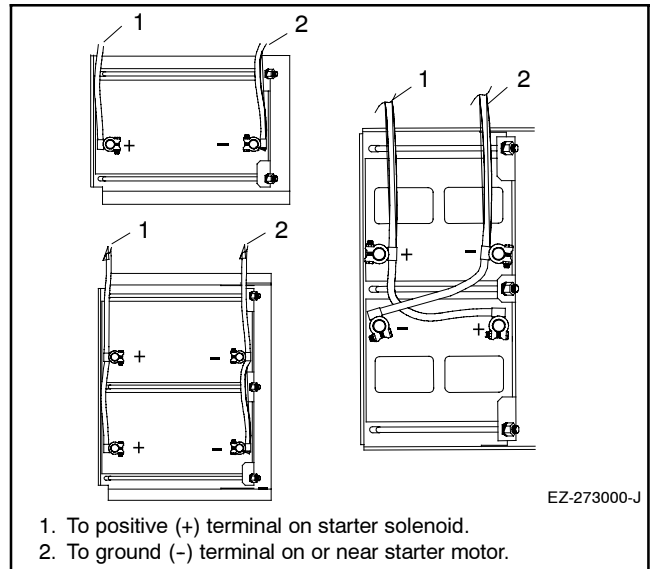

Figure 3-6 12-Volt Engine Electrical System Single Starter Motor Typical Battery Connection

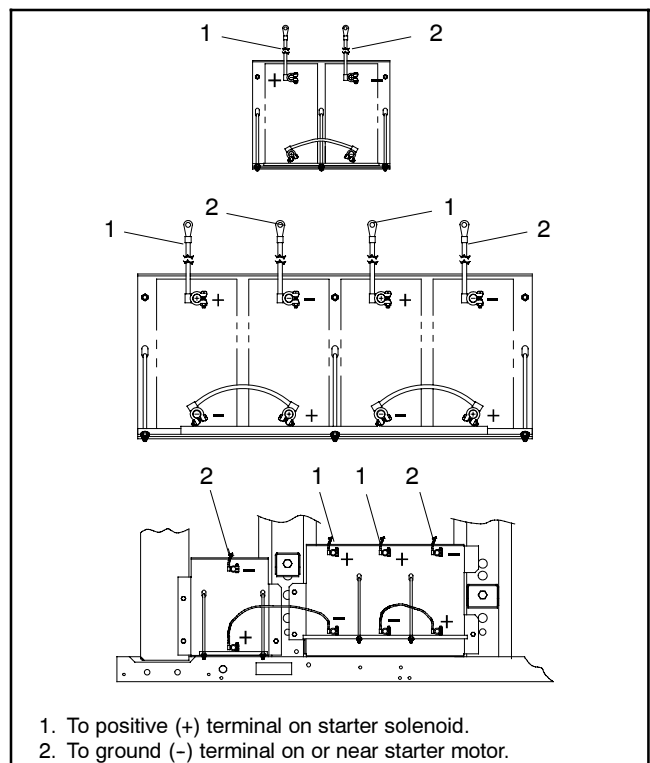

Figure 3-7 24-Volt Engine Electrical System Single Starter Motor Typical Battery Connection

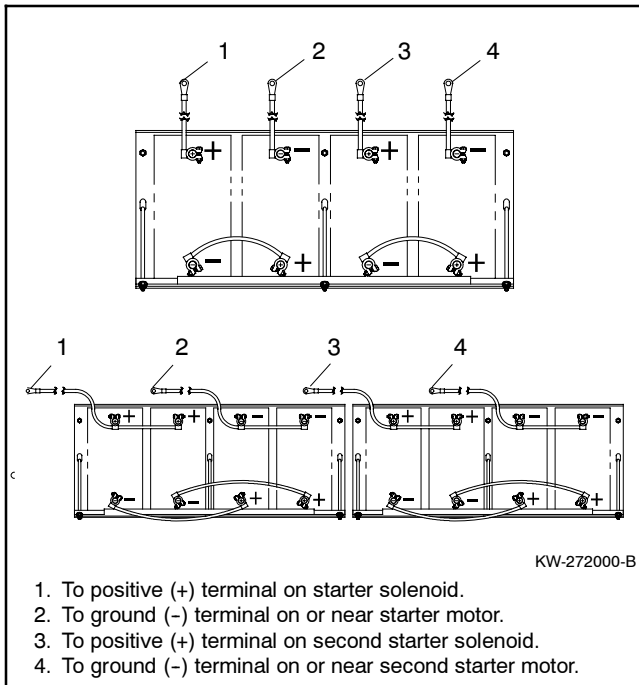

Figure 3-8 24-Volt Engine Electrical System Dual Starter Motors Typical Battery Connections

3.9.1 Clean Battery

Clean the battery and cables and tighten the battery terminals according to the service schedule recommendations. Clean the battery by wiping it with a damp cloth. Keep the electrical connections dry and tight.

If corrosion exists, disconnect the cables from the battery and remove the corrosion with a wire brush. Clean the battery and cables with a solution of baking soda and water. Do not allow the cleaning solution to enter battery cells. Flush the battery and cables with clean water and wipe the battery with a dry cloth.

After reconnecting the battery cables, coat the terminals with petroleum jelly, silicon grease, or other nonconductive grease.

3.9.2 Electrolyte Level Inspection

Check the electrolyte level and specific gravity of batteries that have filler caps. Maintenance-free batteries do not require electrolyte level checking or specific gravity testing.

Check the electrolyte level at the specified interval. Remove the filler caps and verify that the electrolyte level reaches the bottom of each filler hole. See Figure 3-9. Refill as necessary with distilled water or clean tap water. Do not add fresh electrolyte. Tighten the filler caps. After adding water during freezing

temperatures, run the generator set 20-30 minutes to mix the electrolyte and the water to prevent battery damage from freezing.

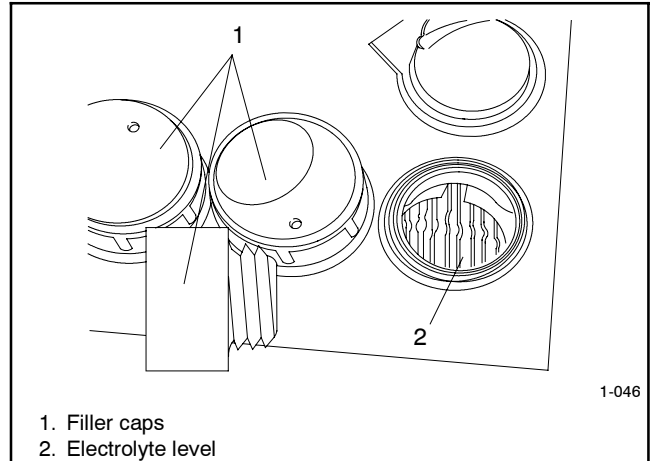

Figure 3-9 Battery Electrolyte Level Inspection

3.9.3 Specific Gravity Check

Use a battery hydrometer to check the specific gravity of the electrolyte in each battery cell of batteries with filler caps. Holding the hydrometer vertically, read the number on the glass bulb at the top of the electrolyte level or the number adjacent to the pointer. If the hydrometer used does not have a correction table, consult Figure 3-11. Determine the specific gravity and electrolyte temperature of the battery cells. Locate the temperature in Figure 3-11 and correct the specific gravity by the amount shown. The battery is fully charged if the specific gravity is 1.260 at an electrolyte temperature of 26.7°C (80°F). Maintain the specific gravities between cells within ±0.01 of each other. Charge the battery if the specific gravity is below 1.215 at an electrolyte temperature of 26.7°C (80°F).

Note: Some battery testers have four or five beads in a test tube. Draw electrolyte into the tube as with the battery hydrometer described in this section or use the manufacturer's instructions. Use Figure 3-10 to interpret typical test results.

Number of Floating Beads	Battery Condition
5	Overcharged
4	Fully charged
3	A good charge
1 or 2	A low charge
0	A dead battery

Figure 3-10 Bead-Type Test Interpretation

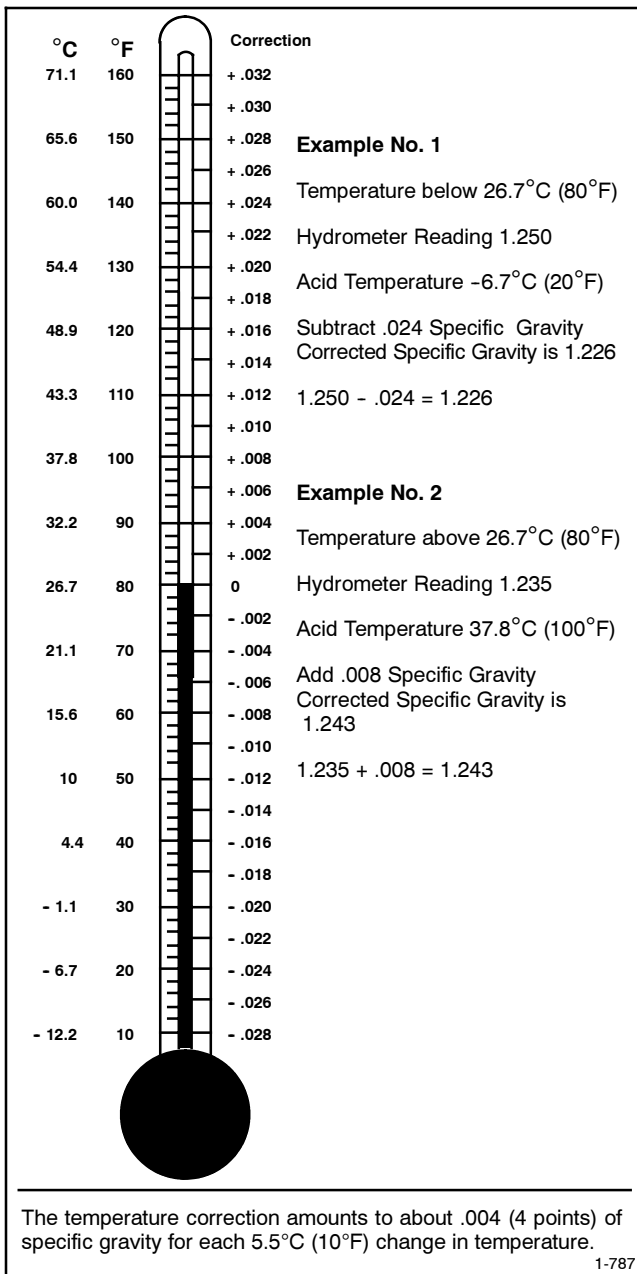

Figure 3-11 Specific Gravity Temperature Correction

3.9.4 Charge Battery

Use a battery charger to maintain a fully charged battery when the generator set is used in a standby application. The engine battery-charging alternator charges the battery while the generator set is running.

Note: If the generator set is in a temporary prime power application in which the generator set has periods of inactivity, the controller circuitry may drain the battery. If there is no power source for a battery charger, place the controller in the prime power mode, if equipped, or disconnect the battery from the generator set.

3.10 Storage Procedure

Perform the following storage procedure before taking a generator set out of service for three months or longer. Follow the engine manufacturer's recommendations, if available, for fuel system and internal engine component storage.

3.10.1 Lubricating System

Prepare the engine lubricating system for storage as follows:

1. Run the generator set for a minimum of 30 minutes to bring it to normal operating temperature.
2. Stop the generator set.
3. With the engine still warm, drain the oil from the crankcase.
4. Remove and replace the oil filter.
5. Refill the crankcase with oil suited to the climate.
6. Run the generator set for two minutes to distribute the clean oil.
7. Stop the generator set.
8. Check the oil level and adjust, if needed.

3.10.2 Cooling System

Prepare the cooling system for storage as follows:

1. Check the coolant freeze protection using a coolant tester.
2. Add or replace coolant as necessary to ensure adequate freezing protection. Use the guidelines included in the engine operation manual.
3. Run the generator set for 30 minutes to redistribute added coolant.

3.10.3 Fuel System

Prepare the fuel system for storage as follows:

Diesel-Fueled Engines

1. Fill the fuel tank with #2 diesel fuel.
2. Condition the fuel system with compatible additives to control microbial growth.
3. Change the fuel filter/separator and bleed the fuel system. See the engine owner's manual.

Gas-Fueled Engines

1. Start the generator set.
2. With the generator set running, shut off the gas supply.
3. Run the generator set until the engine stops.
4. Stop the generator set.

3.10.4 Internal Engine Components (Gas-Fueled Engines)

If you have access to a fogging agent or SAE 10 oil prepare the pistons and cylinders for storage as follows:

1. Start the generator set.
2. While the engine is running, spray a fogging agent or SAE 10 engine oil into the air intake for about two minutes until the engine stops.
3. Stop the generator set.

If a fogging agent is not available perform the following:

1. Remove the spark plugs.
2. Pour 15 cc (0.5 oz.) of engine oil into each spark plug hole.

Ignition System Damage. Refer to the engine operation manual for ignition system precautions before cranking the engine while the spark plug wires are disconnected.

3. Crank the engine two or three revolutions to lubricate the cylinders.
4. Reinstall the spark plugs and torque them to specifications.

3.10.5 Exterior

1. Clean the exterior surface of the generator set.
2. Seal all engine openings except for the air intake with nonabsorbent adhesive tape.
3. To prevent impurities from entering the air intake and to allow moisture to escape from the engine, secure a cloth over the air intake.
4. Mask electrical connections.
5. Spread a light film of oil over unpainted metallic surfaces to inhibit rust and corrosion.

3.10.6 Battery

Perform battery storage after all other storage procedures.

1. Confirm that the generator set is stopped.
2. Disconnect the battery(ies), negative (-) lead first.
3. Clean the battery. Refer to Section 3.9.1 for the battery cleaning procedure.
4. Place the battery in a cool, dry location.
5. Connect the battery to a float/equalize battery charger or charge it monthly with a trickle battery charger. Refer to the battery charger manufacturer's recommendations.

Maintain a full charge to extend battery life.

Section 4 General Troubleshooting

This section contains generator set troubleshooting, diagnostic, and repair information.

Use the following charts to diagnose and correct common problems. First check for simple causes such as a dead engine starting battery or an open circuit breaker. The charts include a list of common problems, possible causes of the problem, recommended corrective actions, and references to detailed information or repair procedures.

Maintain a record of repairs and adjustments performed on the equipment. If the procedures in this manual do not explain how to correct the problem, contact an authorized distributor/dealer. Use the record to help describe the problem and repairs or adjustments made to the equipment.

4.1 General Troubleshooting Chart

Trouble Symptoms													Probable Causes	Recommended Actions	Section or Publication Reference*
Does not crank	Cranks but does not start	Starts hard	No or low output voltage	Stops suddenly	Lacks power	Overheats	Low oil pressure	High fuel consumption	Excessive or abnormal noise	Displays error message/locks up	Exercise run time and/or event records inoperative				
Controller															
x	x												Controller circuit board(s) inoperative	Replace the controller.	Gen. S/M
x	x												Controller circuit board(s) wiring fault	Check the wiring.	W/D
				x									Controller fault	Troubleshoot the controller.†	Gen. S/M
x	x			x									Controller fuse blown	Check for continuity across fuse. If fuse is blown, troubleshoot the controller wiring and replace circuit board.†	Section 1, W/D
x													Controller master control buttons inoperative	Replace the controller master control button circuit board.	—
x													Controller master control button in the OFF/RESET mode	Press the controller master control RUN or AUTO button.	Section 2
x													Engine start circuit open	Press the controller master control RUN button to test the generator set. Troubleshoot the auto start circuit and time delays.	Section 2, W/D, Gen. I/M, S/M ATS O/M, S/M
			x	x									Voltage regulation inoperative	Replace the junction box sensing fuses. If the fuse blows again, troubleshoot the controller.	W/D, Gen. S/M
										x			Controller firmware error	Review the controller display troubleshooting chart.	Section 4.2
Alternator															
			x										AC output circuit breaker open	Reset the breaker and check for AC voltage at the generator set side of the circuit breaker.	—
x													Transfer switch test switch in the OFF position	Move the transfer switch test switch to the AUTO position.	ATS O/M
			x										Transfer switch fails to transfer load	Move the ATS test switch to the AUTO position. Troubleshoot the transfer circuit and time delays.	ATS O/M, S/M
			x										Wiring, terminals, or pin in the exciter field open	Check for continuity.	Gen. S/M, W/D
			x										Main field (rotor) inoperative (open or grounded)	Test and/or replace the rotor.†	Gen. S/M
			x										Stator inoperative (open or grounded)	Test and/or replace the stator.†	Gen. S/M
									x				Vibration excessive	Tighten loose components.†	—
			x										Voltage regulator settings incorrect	Adjust the voltage regulator.	Section 1.3.3, SiteTech O/M
<p>* Sec./Section—numbered section of this manual; ATS—Automatic Transfer Switch; Eng.—Engine; Gen.—Generator Set; I/M—Installation Manual; O/M—Operation Manual; S/M—Service Manual; S/S—Spec Sheet; W/D—Wiring Diagram Manual</p> <p>† Have an authorized service distributor/dealer perform this service.</p>															

Trouble Symptoms													Probable Causes	Recommended Actions	Section or Publication Reference*
Does not crank	Cranks but does not start	Starts hard	No or low output voltage	Stops suddenly	Lacks power	Overheats	Low oil pressure	High fuel consumption	Excessive or abnormal noise	Displays error message/locks up	Exercise run time and/or event records inoperative				
Electrical System (DC Circuits)															
x	x												Battery connections loose, corroded, or incorrect	Verify that the battery connections are correct, clean, and tight.	Section 3
x	x												Battery weak or dead	Recharge or replace the battery. The spec sheet provides recommended battery CCA rating.	Section 3, S/S
x	x												Starter/starter solenoid inoperative	Replace the starter or starter solenoid.	Eng. S/M
x				x									Engine harness connector(s) not locked tight	Disconnect the engine harness connector(s) then reconnect it to the controller.	W/D
				x									Fault shutdown	Reset the fault switches and troubleshoot the controller.	Section 2
Engine															
	x	x			x			x					Air cleaner clogged	Clean or replace the filter element.	Eng. O/M
	x	x				x		x	x				Compression weak	Check the compression.†	Eng. S/M
			x		x	x		x	x				Engine overload	Reduce the electrical load. See the generator set spec sheet for wattage specifications.	S/S
									x				Exhaust system leak	Inspect the exhaust system. Replace the inoperative exhaust system components.†	I/M
									x				Exhaust system not securely installed	Inspect the exhaust system. Tighten the loose exhaust system components.†	I/M
		x	x		x			x					Governor inoperative	Adjust the governor.†	Eng. S/M
					x				x				Valve clearance incorrect	Adjust the valves.†	Eng. S/M
									x				Vibration excessive	Tighten all loose hardware.	—
	x	x			x								Ignition system inoperative (gas models only)	Check the ignition system (spark plugs, spark plug wires, etc.).	Eng. O/M, Eng. S/M
x	x			x						x	x		Engine ECM and/or sensors	Troubleshoot the engine ECM and/or sensors.	Eng. O/M, Eng. S/M
<p>* Sec./Section—numbered section of this manual; ATS—Automatic Transfer Switch; Eng.—Engine; Gen.—Generator Set; I/M—Installation Manual; O/M—Operation Manual; S/M—Service Manual; S/S—Spec Sheet; W/D—Wiring Diagram Manual</p> <p>† Have an authorized service distributor/dealer perform this service.</p>															

Trouble Symptoms												Probable Causes	Recommended Actions	Section or Publication Reference*
Does not crank	Cranks but does not start	Starts hard	No or low output voltage	Stops suddenly	Lacks power	Overheats	Low oil pressure	High fuel consumption	Excessive or abnormal noise	Displays error message/locks up	Exercise run time and/or event records inoperative			
Cooling System														
						x		x				Air openings clogged	Clean the air openings.	—
						x						Coolant level low	Restore the coolant to normal operating level.	Section 3
						x						Cooling water pump inoperative	Tighten or replace the belt. Replace the water pump.	Eng. O/M or S/M
				x								High temperature shutdown	Allow the engine to cool down. Then troubleshoot the cooling system.	Sec. 3, Eng. O/M
				x								Low coolant level shutdown, if equipped	Restore the coolant to normal operating level.	Section 3
						x						Thermostat inoperative	Replace the thermostat.	Eng. S/M
Fuel System														
	x	x			x							Air in fuel system (diesel only)	Bleed the diesel fuel system.	Eng. O/M
	x	x										Ether canister empty or system inoperative, if equipped (diesel only)	Replace or repair the ether starting system.	Eng. O/M
	x			x								Fuel tank empty or fuel valve shut off	Add fuel and move the fuel valve to the ON position.	—
	x				x			x				Fuel feed or injection pump inoperative (diesel only)	Rebuild or replace the injection pump.†	Eng. S/M
	x	x			x							Fuel or fuel injectors dirty or faulty (diesel only)	Clean, test, and/or replace the inoperative fuel injector.†	Eng. S/M
	x	x		x	x							Fuel filter restriction	Clean or replace the fuel filter.	Eng. O/M
	x											Fuel solenoid inoperative	Troubleshoot the fuel solenoid.†	Eng. S/M
	x				x							Fuel pressure insufficient (gas only)	Check the fuel supply and valves.†	S/S, Gen. O/M
	x	x			x			x				Fuel injection timing out of adjustment (diesel only)	Adjust the fuel injection timing.†	Eng. S/M
Lube System														
	x	x					x		x			Crankcase oil type incorrect for ambient temperature	Change the oil. Use oil with a viscosity suitable for the operating climate.	Eng. O/M
						x	x		x			Oil level low	Restore the oil level. Inspect the generator set for oil leaks.	Eng. O/M
				x								Low oil pressure shutdown	Check the oil level.	Eng. O/M
* Sec./Section—numbered section of this manual; ATS—Automatic Transfer Switch; Eng.—Engine; Gen.—Generator Set; I/M—Installation Manual; O/M—Operation Manual; S/M—Service Manual; S/S—Spec Sheet; W/D—Wiring Diagram Manual														
† Have an authorized service distributor/dealer perform this service.														

4.2 Controller Display and Voltage Regulation Troubleshooting Chart

Trouble Symptoms	Probable Causes	Recommended Actions	Section or Publication Reference*
Controller Display and Voltage Regulator			
Display is black	No/low battery charge	Recharge/replace battery	Section 3, Battery
Display shows single segment	Low battery voltage	Recharge battery	Section 3, Battery
Display shows an error message	Controller firmware or pushbutton/rotary selector dial entry error	Review the Error Message Section	Section 2.6.1
Display locks up	No/low battery charge	Recharge/replace battery	Section 3, Battery
Output voltage ramps	Defective exciter winding	Troubleshoot alternator components †	Generator Service Manual
Output voltage unstable	Voltage regulation calibration incorrect	Readjust voltage regulation †	Section 1.3.3, SiteTech O/M
Unable to change voltage and current calibrations	Calibration not enabled	Enable calibration in Generator Metering section	Section 1.2.3 Digital Display, Section 2.6.4
Unable to find volt select menu	Volt select not enabled	Enable volt select in SiteTech	SiteTech O/M
<p>* Sec./Section—numbered section of this manual; ATS—Automatic Transfer Switch; Eng.—Engine; Gen.—Generator Set; I/M—Installation Manual; O/M—Operation Manual; S/M—Service Manual; S/S—Spec Sheet; W/D—Wiring Diagram Manual</p> <p>† Have an authorized service distributor/dealer perform this service.</p>			

Notes

Section 5 Voltage Reconnection

5.1 Introduction

Use the following voltage reconnection procedure to change the voltage of 10- and 12-lead generator sets. Frequency changes require voltage regulator *and* governor adjustments. Refer to the respective spec sheet to determine if frequency is fixed or field-convertible. If frequency is adjustable, refer to the engine service manual and/or governor literature for conversion information.

Refer to the following procedure and the connection schematics. Follow the safety precautions at the front of this manual and in the procedure text and observe National Electrical Code (NEC) guidelines.

NOTICE

Voltage reconnection. Affix a notice to the generator set after reconnecting the set to a voltage different from the voltage on the nameplate. Order voltage reconnection decal 246242 from an authorized service distributor/dealer.

Note: Equipment damage. Verify that the voltage ratings of the transfer switch, line circuit breakers, and other accessories match the selected line voltage.

⚠ WARNING

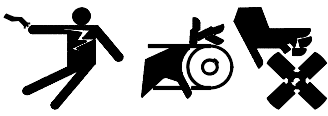

**Accidental starting.
Can cause severe injury or death.**

Disconnect the battery cables before working on the generator set. Remove the negative (-) lead first when disconnecting the battery. Reconnect the negative (-) lead last when reconnecting the battery.

Disabling the generator set. Accidental starting can cause severe injury or death. Before working on the generator set or equipment connected to the set, disable the generator set as follows: (1) Turn the generator set master switch and switchgear engine control switch to the OFF position. (2) Disconnect the power to the battery charger. (3) Remove the battery cables, negative (-) lead first. Reconnect the negative (-) lead last when reconnecting the battery. Follow these precautions to prevent the starting of the generator set by an automatic transfer switch or a remote start/stop switch.

Disabling the generator set. Accidental starting can cause severe injury or death. Before working on the generator set or connected equipment, disable the generator set as follows: (1) Move the generator set master switch to the OFF position. (2) Disconnect the power to the battery charger. (3) Remove the battery cables, negative (-) lead first. Reconnect the negative (-) lead last when reconnecting the battery. Follow these precautions to prevent starting of the generator set by an automatic transfer switch, remote start/stop switch, or engine start command from a remote computer.

⚠ WARNING

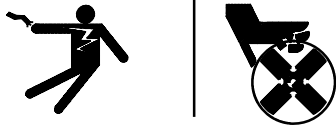

**Hazardous voltage. Moving parts.
Can cause severe injury or death.**

Operate the generator set only when all guards and electrical enclosures are in place.

Grounding electrical equipment. Hazardous voltage can cause severe injury or death. Electrocutation is possible whenever electricity is present. Ensure you comply with all applicable codes and standards. Electrically ground the generator set, transfer switch, and related equipment and electrical circuits. Turn off the main circuit breakers of all power sources before servicing the equipment. Never contact electrical leads or appliances when standing in water or on wet ground because these conditions increase the risk of electrocution.

Short circuits. Hazardous voltage/current can cause severe injury or death. Short circuits can cause bodily injury and/or equipment damage. Do not contact electrical connections with tools or jewelry while making adjustments or repairs. Remove all jewelry before servicing the equipment.

5.2 Voltage Reconnection Procedure

(Software version 2.8 or higher)

1. Press the generator set master control OFF/RESET button.
2. Turn the controller pushbutton/rotary selector dial until it stops at the Volt Select menu. See Figure 5-1.

Note: If the Volt Select menu does not appear, the controller voltage selection feature was not activated using SiteTech™ software.

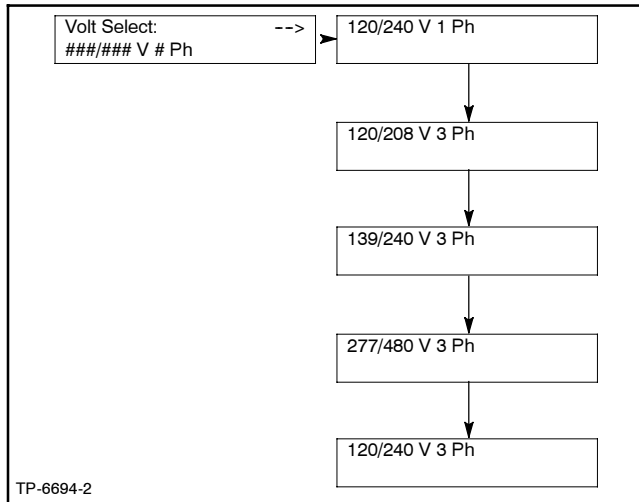

Figure 5-1 Volt Select Menu

3. Press the selector dial and the voltage selection option (second line on the display) will start to flash.
4. Turn the selector dial clockwise or counterclockwise until the desired voltage selection option appears.
5. Press the selector dial. The second line on the display will stop flashing and the new voltage will appear.
6. Rotate the generator set voltage selector switch (if equipped) to match the desired voltage shown on the controller display. Skip steps 7–9 and go to step 10.

If the generator set does not have a voltage selection switch, continue to step 7

7. Disconnect the generator set engine starting battery, negative (-) lead first. Disconnect power to the battery charger (if equipped).

8. Use Figure 5-2, Figure 5-3, or Figure 5-4 to determine the generator set voltage configuration. Note the original voltage and reconnect as needed. Route leads through current transformers (CTs) and connect them according to the diagram for the desired phase and voltage.

Note: Position current transformers CT1, CT2, and CT3 with the dot or HI side CT marking toward the generator set.

9. Reconnect the battery, negative lead last.
10. Press the generator set master control RUN button to start the generator set. Check the digital display for correct voltages using 2.6.4 Generator Metering.
11. Press the generator set master control OFF/RESET button to stop the generator set after completing the voltage adjustments.

5.3 Voltage Reconnection Procedure

(Software version before 2.8)

1. Press the generator set master control OFF/RESET button.
2. Disconnect the generator set engine starting battery, negative (-) lead first. Disconnect power to the battery charger (if equipped).
3. Use Figure 5-2, Figure 5-3, or Figure 5-4 to determine the generator set voltage configuration. Note the original voltage and reconnect as needed. Route leads through current transformers (CTs) and connect them according to the diagram for the desired phase and voltage.

Note: Position current transformers CT1, CT2, and CT3 with the dot or HI side CT marking toward the generator set.

4. Reconnect the battery, negative lead last.
5. Use SiteTech™ software to update the information.
6. Refer to 2.6.8 for generator set calibration at the controller.
7. Press the generator set master control RUN button to start the generator set. Check the digital display for correct voltages using 2.6.4 Generator Metering.
8. Press the generator set master control OFF/RESET button to stop the generator set after completing the voltage adjustments.

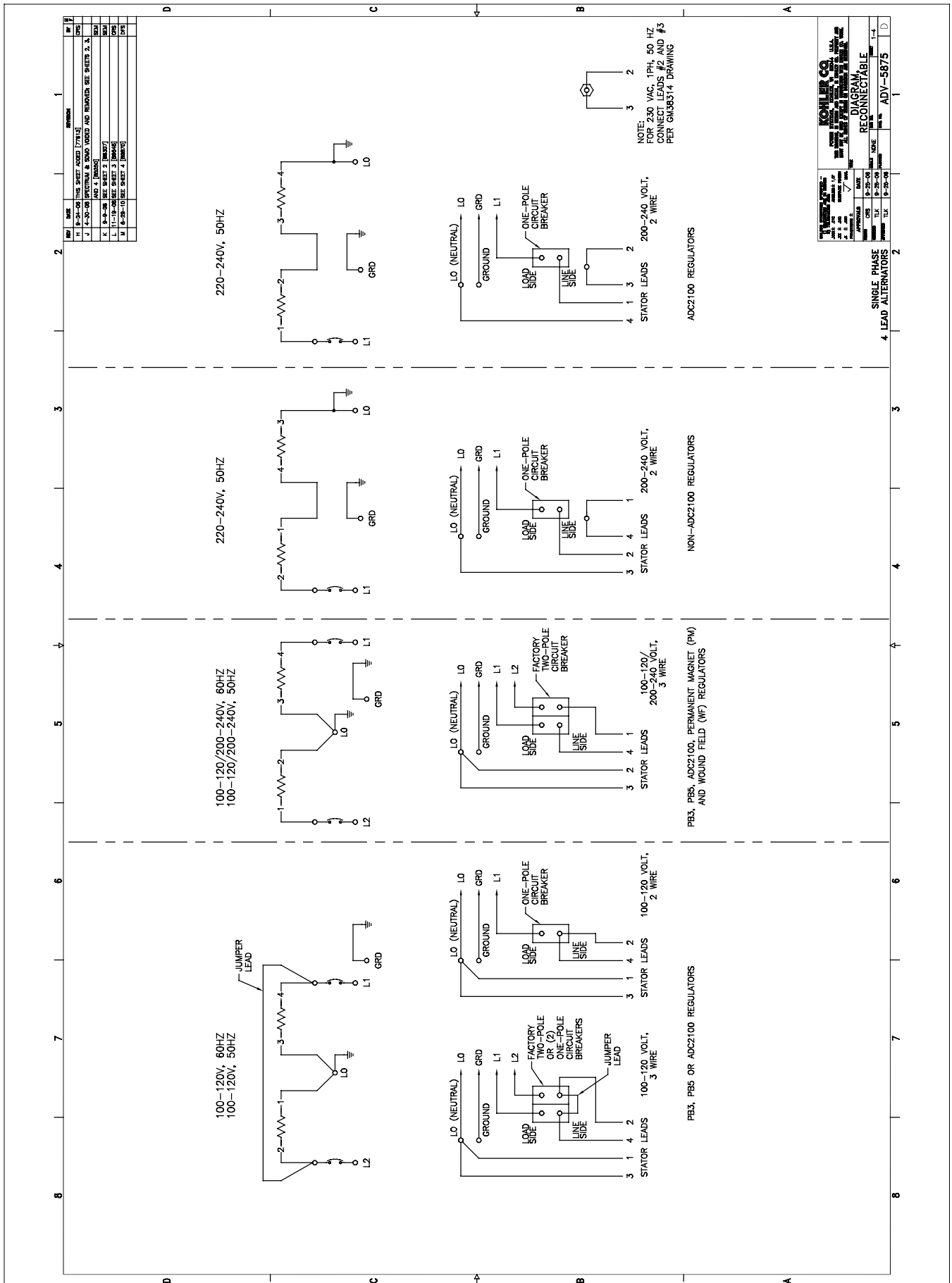

Figure 5-2 20-150 kW Permanent Magnet Single-Phase Alternators, ADV-5875A-M

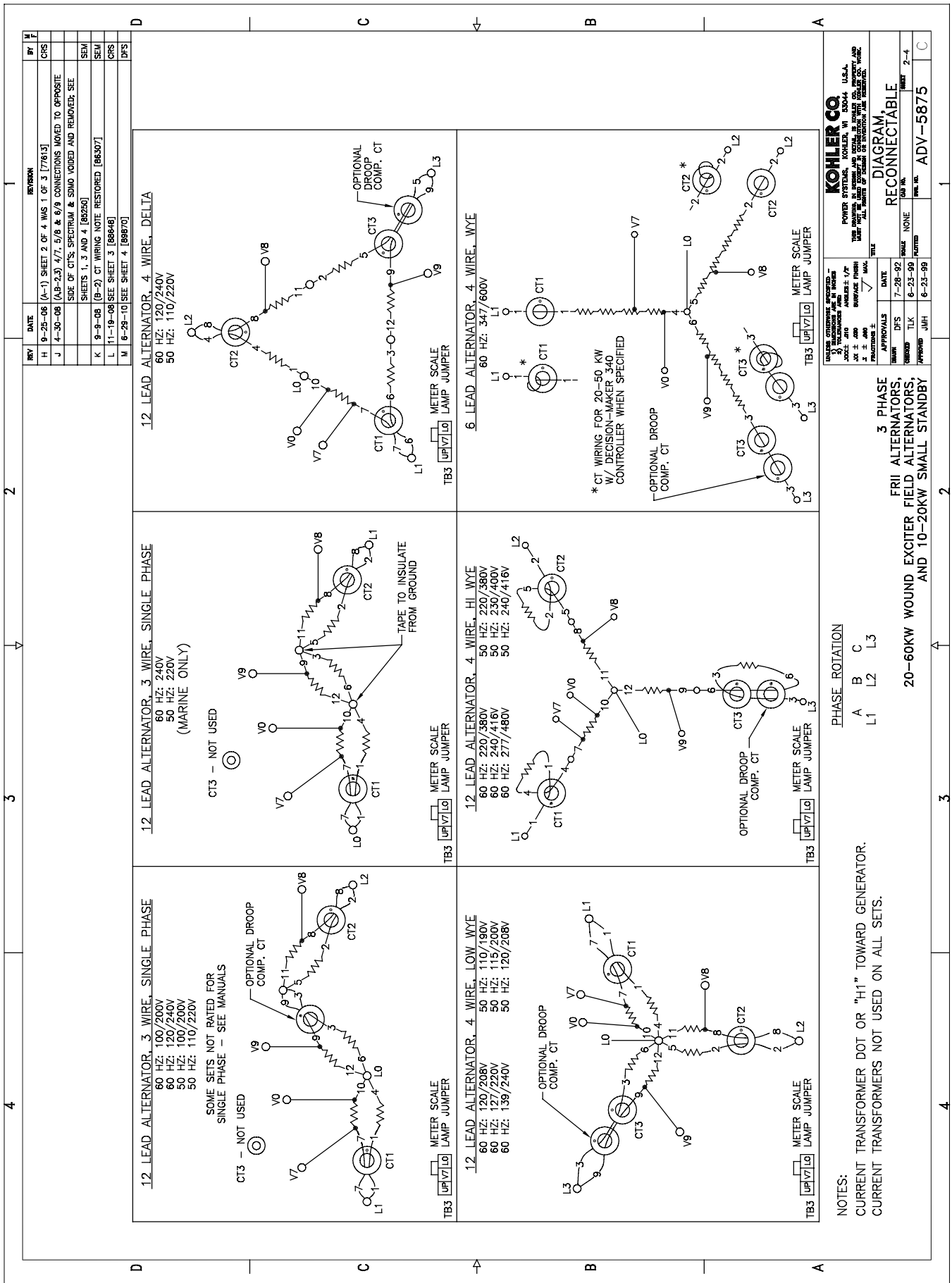

Figure 5-3 20-300 kW (190-480 Volt) Permanent Magnet Alternators, ADV-5875B-M

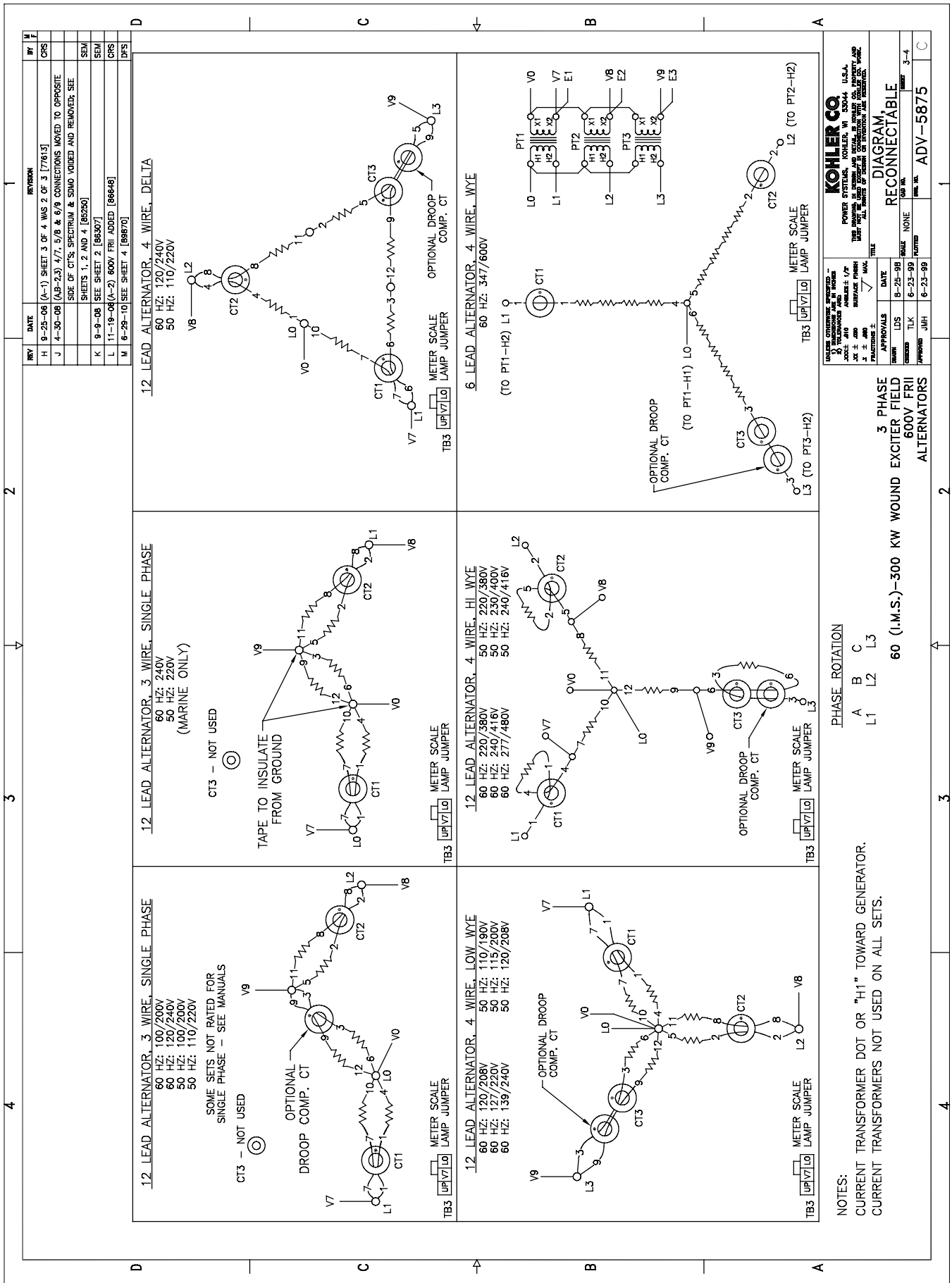

Figure 5-4 20-300 kW (600 Volt) Alternators, ADV-5875C-M

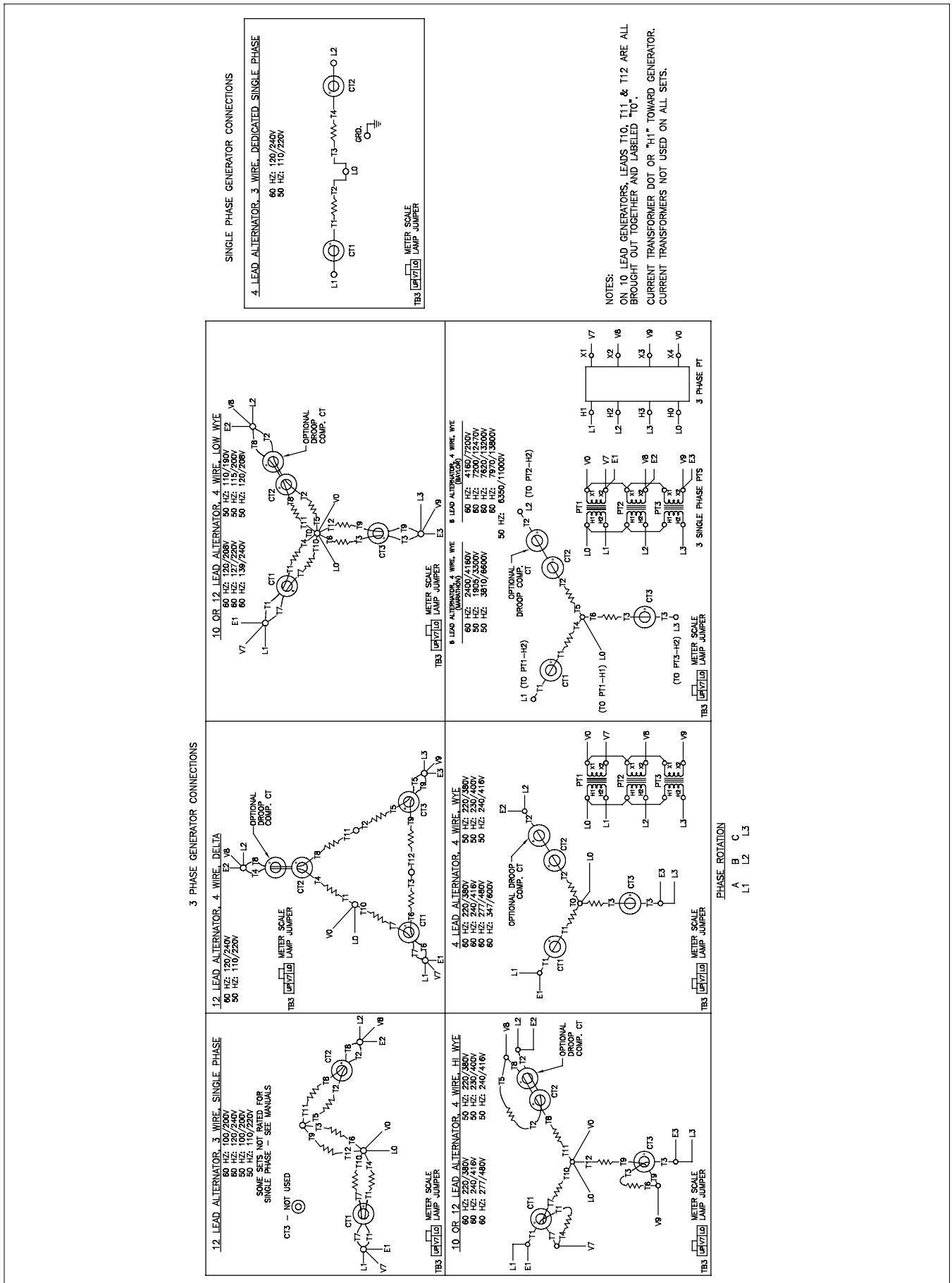

Figure 5-5 300 kW and Larger Pilot-Excited, Permanent Magnet 4M/5M/7M/10M Alternators, ADV-5875D-M

6.1 Accessories and Connections

Several accessories help finalize installation, add convenience to operation and service, and establish state and local code compliance.

Accessories vary with each generator set model and controller. Select factory-installed and/or shipped-loose accessories. See Figure 6-1 for a list of available kits. Obtain the most current accessory information from your local authorized service distributor/dealer.

This section illustrates several accessories available at print time of this publication. Accessory kits generally include installation instructions. See wiring diagrams manual for electrical connections not shown in this section. See the installation instructions and drawings supplied with kit for information on kit mounting location.

The instructions provided with the accessory kit supersede these instructions where there are differences. In general, run AC and DC wiring in separate conduit. Use shielded cable for all analog inputs. Observe all applicable national, state, and local electrical codes during accessory installation.

See Section 6.2, Accessory Connections, for terminal identification.

Kit Description
Common Fault/Failure (32A) Connections
Float/Equalize Battery Charger (with alarms)
Gas Fuel Valve
Input/Output Module Board
Low Fuel (Level) Switch
Low Fuel (Pressure) Switch
Prime Power Switch
Remote Emergency Stop
Remote Reset Feature
Remote Serial Annunciator
Run Relay
Shunt-Trip Line Circuit Breaker

Figure 6-1 Optional Accessories

6.1.1 Common Fault/Failure (32A) Relay Kit

The common fault relay is standard on the controller circuit board and located at the TB2 terminal strip connections. Contacts are rated at 2 amps at 32 VDC or 0.5 amps at 120 VAC max. See Figure 6-2 and Figure 6-3.

The optional common fault relay shown in Figure 6-3 as DCB2 has contacts rated at 10 amps at 28 VDC or 120 VAC and can be connected to user-supplied accessories.

The optional common fault relay shown in Figure 6-3 as DCB1 has contacts rated at 10 amps at 28 VDC or 120 VAC and is used to trigger the shunt-trip line circuit breaker kit (mentioned later in this section).

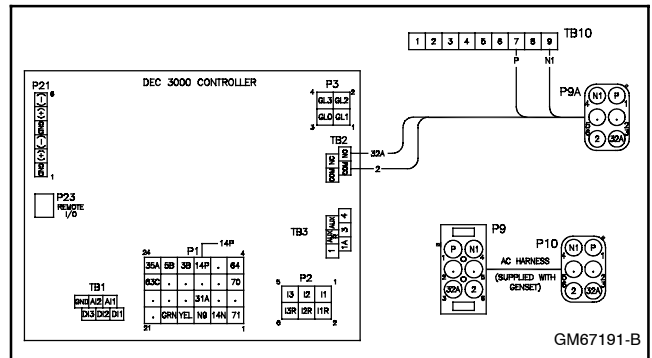

Figure 6-2 Common Fault Relay Wiring (Standard)

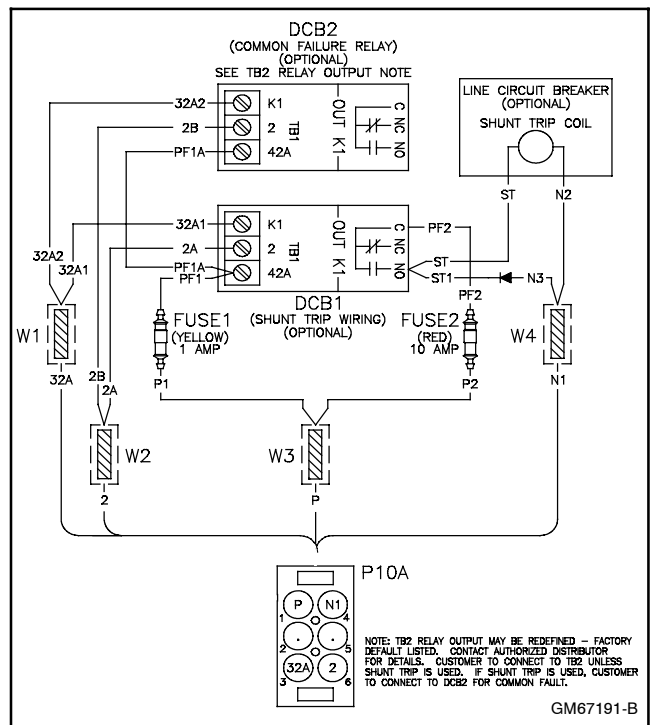

Figure 6-3 Common Fault Relay Kit and Shunt-Trip Relay Kit Wiring

6.1.2 Float/Equalize Battery Charger Kit with Alarm Option

The float/equalize battery charger with alarm option provides battery charging to the engine starting battery(ies) and connects to the controller for fault detection. Battery chargers for 12- or 24-volt models are available as a generator set accessory. See Figure 6-4 and Figure 6-5 for battery connections.

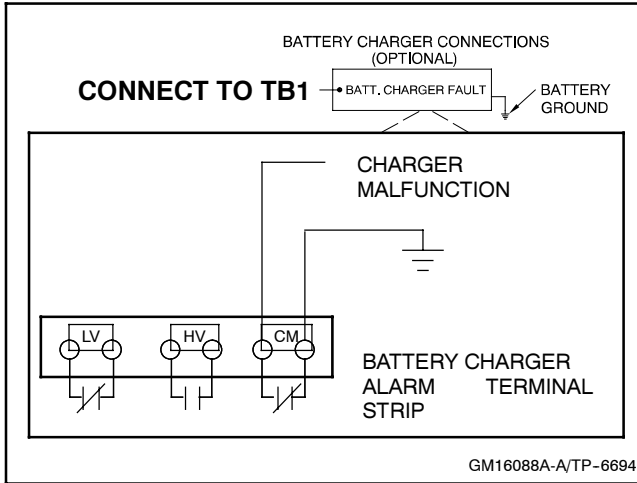

Figure 6-4 Float/Equalize Battery Charger Connections

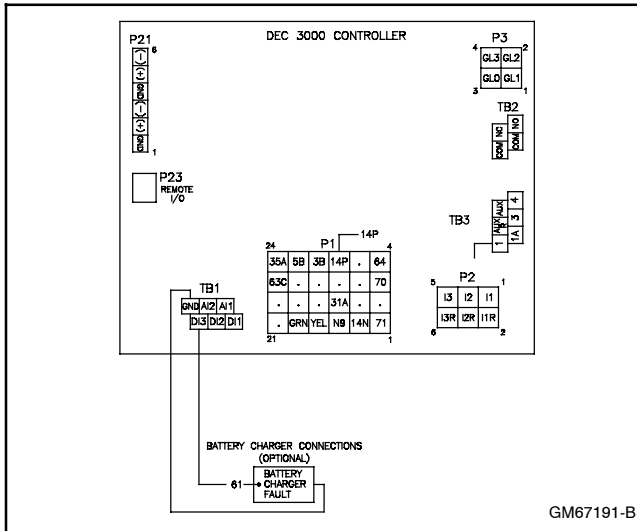

Figure 6-5 Battery Charger to Controller Connections

6.1.3 Gas Fuel Valve Kit

This section provides the wiring information for an *additional* gas fuel valve kit required for UL Approval. See Figure 6-6. Refer to the respective generator set wiring diagrams for additional information and for LP liquid applications.

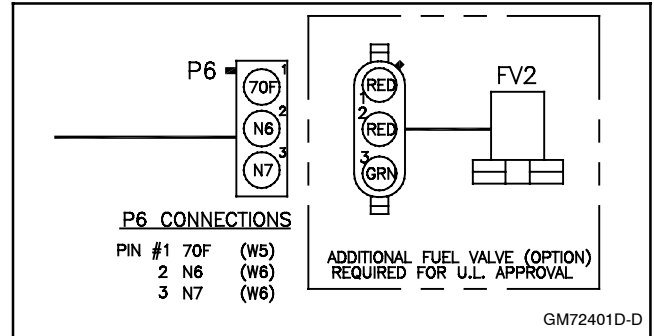

Figure 6-6 Gas Fuel Valve Kit Connections

6.1.4 Input/Output (I/O) Module Board

The I/O module board provides a generator set mounted panel with two analog or digital inputs and five digital outputs. See Figure 6-7 for circuit board components and electrical connections to the controller. See

Figure 6-8 for connections of analog inputs. Refer to Figure 6-27 for accessory connections.

See Section 6.2, Accessory Connections, for terminal identification.

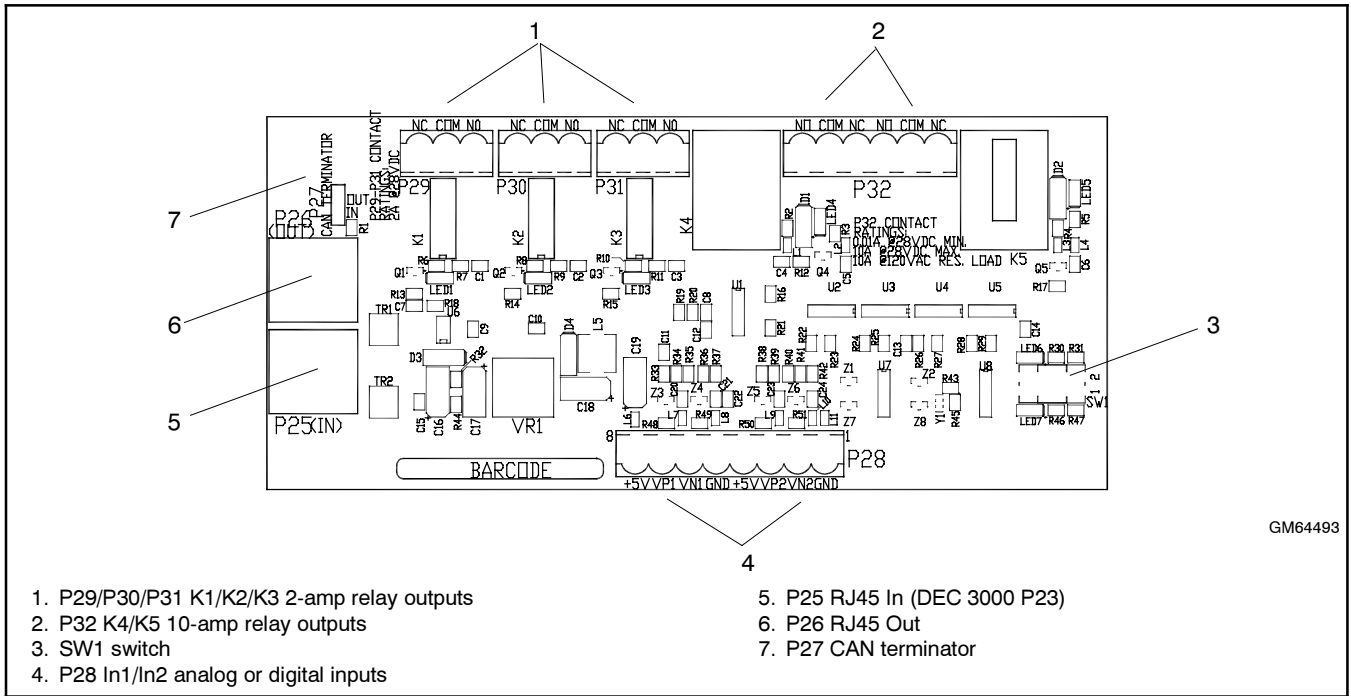

Figure 6-7 Input/Output (I/O) Module Board Kit

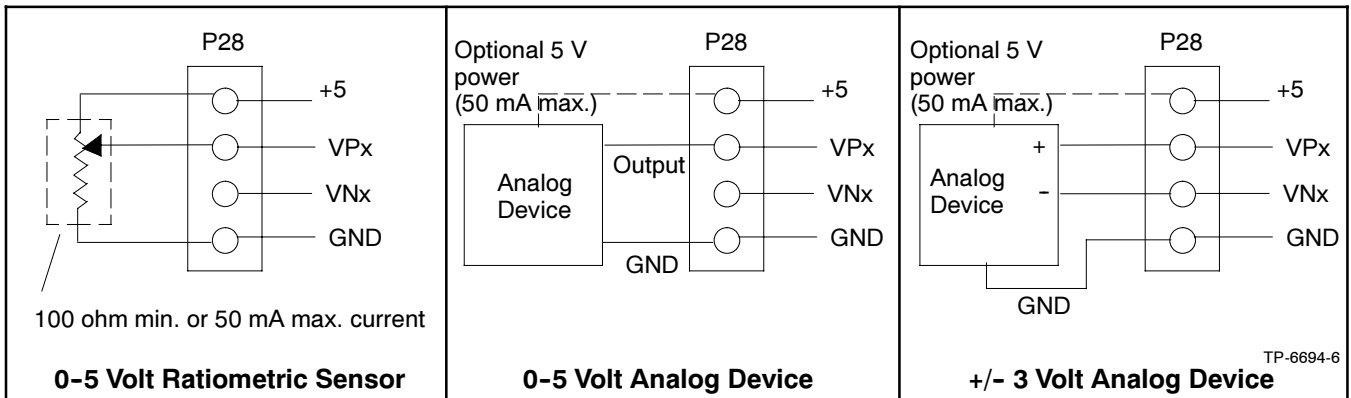

Figure 6-8 Analog Input Connections P28

6.1.5 Low Fuel (Level/Pressure) Switch

Some gas-fueled models offer a low fuel pressure switch. The low fuel pressure switch connects to the same controller terminal as the low fuel *level* switch on diesel-fueled models. See Figure 6-9, Figure 6-10, and Figure 6-11.

Note: The main tank or the transfer/day tank includes the low fuel level switch. The fuel tank supplier typically provides the low fuel level switch.

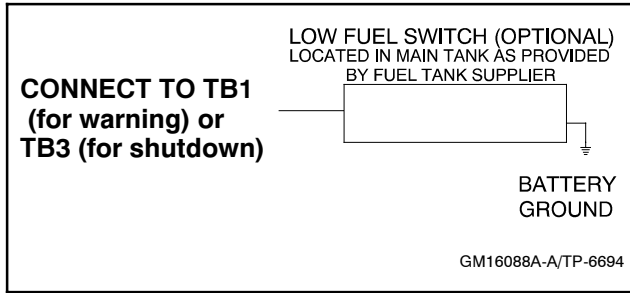

Figure 6-9 Low Fuel Switch (Level or Pressure)

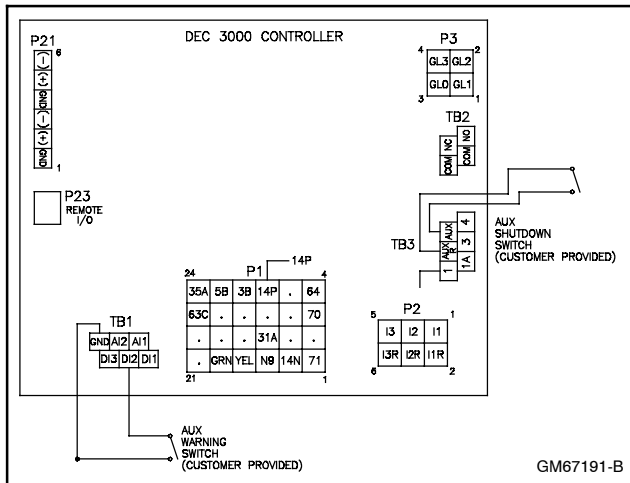

Figure 6-10 Low Fuel Switch Connection to Controller Connection

Switch Rating	12 volts DC minimum, 0.5 amp minimum
Wiring Recommendation	
Gauge	mm (ft.)
18-20	30.5 (100)
14	153 (500)
10	305 (1000)

Figure 6-11 Switch Rating & Wiring Recommendation

6.1.6 Prime Power Switch Kit

The prime power switch kit prevents battery drain during generator set non-operation periods and when the generator set battery cannot be maintained by an AC battery charger. See Figure 6-12 for an illustration of the kit and Figure 6-13 for the electrical connections.

Stop the generator set using the stopping procedures in Section 2.3.2, Stopping, before placing the generator set in the prime power mode. Move the prime power switch located on the junction box to the *DOWN* position. The controller including the digital display, LEDs, and alarm horn does not function when the generator set is in the prime power mode.

Move the prime power switch located on the junction box to the *UP* position. The generator set is now ready for starting.

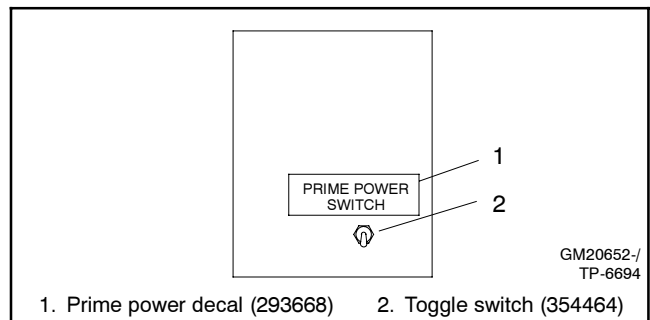

Figure 6-12 Prime Power Switch

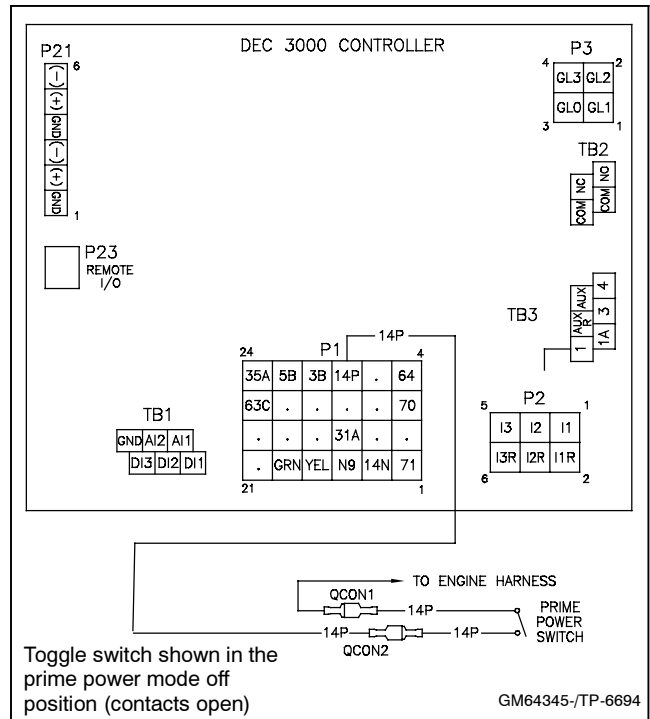

Figure 6-13 Prime Power Switch Connections

6.1.7 Remote Emergency Stop Kit

The emergency stop kit allows immediate shutdown of the generator set from a remote location. See Figure 6-14 and Figure 6-15. If the emergency stop switch activates, the EMERGENCY STOP lamp lights and the unit shuts down. Before attempting to restart the generator set, reset the emergency stop switch (by replacing the glass piece) and reset the generator set by pressing the master control switch OFF/RESET button.

Use the single glass piece located inside the switch for replacement and order additional glass pieces as service parts. See Section 2.3.3, Emergency Stop Switch Resetting.

See Section 6.2, Accessory Connections, for terminal identifications.

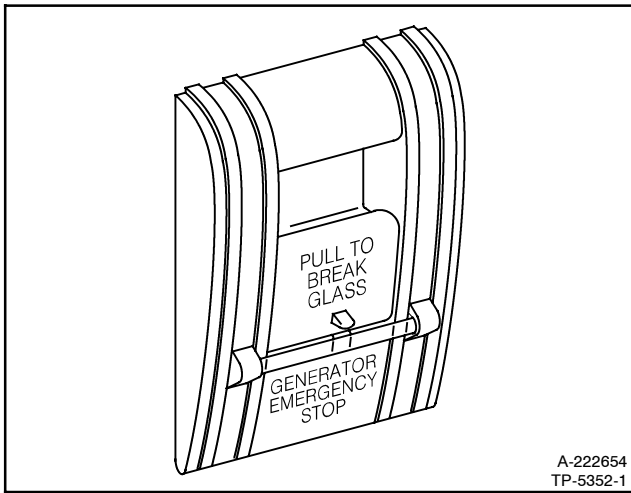

Figure 6-14 Emergency Stop Kit

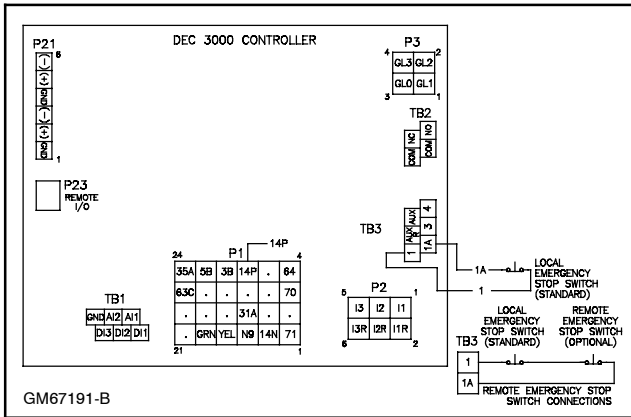

Figure 6-15 Remote Emergency Stop Kit Connections

6.1.8 Remote Reset Feature

The remote reset switch provides generator set controller resetting after a fault shutdown at a remote location. See Figure 6-16 and Figure 6-17 for user-supplied switch connection.

Press and hold the switch for 2-3 seconds and release to reset the generator set controller.

See Section 6.2, Accessory Connections, for terminal identifications.

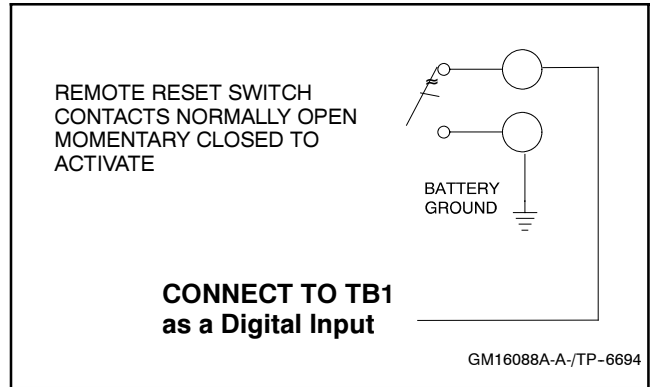

Figure 6-16 Remote Reset Switch Connections

Switch Rating	12 volts DC minimum, 1 amp minimum
Wiring Recommendation	
Gauge	m (ft.)
18-20	30.5 (100)
14	153 (500)
10	305 (1000)

Figure 6-17 Switch Rating and Wiring Recommendations

6.1.9 Remote Serial Annunciator

RSA II is an annunciator panel offered in several kit configurations to support Kohler power equipment. The RSA II is a remote serial annunciator Figure 6-18 and Figure 6-19 that monitors the condition of the generator set and/or ATS from a remote location. The RSA II alerts the operator through visual and audible signals using LED indication and a horn. An alarm silence and lamp test switch are included.

The RSA II meets NFPA 110, Level 1 applications that require remote controls and alarms be powered by a storage battery such as the engine starting battery. An AC adaptor kit is available when NFPA is not required.

The front panel decals include areas that can be used to identify user-selected fault inputs and identify associated power system equipment.

An RSA II annunciator can be used for a single generator set or with a combination of a generator set and automatic transfer switch. In systems using more than a single RSA II, one must be designated as the master device to broadcast to additional RSA II annunciators, designated as slave devices. Up to five RSA II slave devices can be used with an RSA II master device. All RSA II annunciators are factory set as the master device, but can be changed to a slave device using a PC and SiteTech™ software that connects to the RSA II front panel via a universal serial bus (USB) connection.

The RSA 1000 can be connected with the RSA II provided that the master remote annunciator is an RSA II.

Refer to TT-1485 Remote Serial Annunciator (RSA II) Kits for operation and installation instructions.

A PC with SiteTech™ software is required to make the RSA II functional. Use your SecurID to access KOHLERnet, click on the TechTools button, and follow the instructions to download the files. Refer to the SiteTech™ Software Operation Manual for more information.

The RSA II kits include components for surface mounting or flush mounting.

Figure 6-20 shows the status of the system ready LED, generator set running LED, communication status LED, common fault LED, common fault output, and horn for each fault or status condition.

If the RSA II is used with an Ethernet communication network, order Modbus® Ethernet converter GM41143-KP2 and refer to TT-1405 Converters, Connections, and Controller Setup for Network Communication for system installation.

Modbus® is a registered trademark of Schneider Electric.



Figure 6-18 Remote Serial Annunciator (RSA II)



Figure 6-19 RSA II with ATS Controls

See Section 6.2, Accessory Connections, for terminal identifications.

Fault and Status Condition	System Monitoring LEDs and Functions						
	Fault LED	System Ready LED	Generator Running LED	Communication Status LED	Common Fault LED	Common Fault Output	Horn
Overcrank Shutdown	Red	Red SF	Off	Green	Red SF	On	On
High Engine Temperature Warning *	Yellow	Red SF	Green	Green	Red SF	On	On
High Engine Temperature Shutdown	Red	Red SF	Off	Green	Red SF	On	On
Low Oil Pressure Warning *	Yellow	Red SF	Green	Green	Red SF	On	On
Low Oil Pressure Shutdown	Red	Red SF	Off	Green	Red SF	On	On
Overspeed Shutdown	Red	Red SF	Off	Green	Red SF	On	On
Emergency Stop *	Red	Red SF	Off	Green	Off	On	On
Low Coolant Level/Auxiliary Shutdown *	Red	Red SF	Off	Green	Red SF	On	On
Low Coolant Temperature *	Yellow	Red SF	Off	Green	Red SF	On	On
Low Fuel—Level or Pressure *	Yellow	Red SF	Off	Green	Red SF	On	On
EPS Supplying Load (RSA II)	Green	Green	Green or Off	Green	Off	Off	Off
System Ready	Green	Green	Green or Off	Green	Off	Off	Off
System Not Ready	Red	Red SF	Green or Off	Green	Off	On	On
Low Cranking Voltage	Yellow	Red SF	Off	Green	Red SF	On	On
(Loss of) Communication Status (Master RSA II)	Red	Off	Off	Red FF	Off	On	On
(Loss of) Communication Status (Slave RSA II)	Red	Off	Off	Red SF	Off	On	On
Not-In-Auto	Red	Red SF	Green or Off	Green	Red SF	On	On
Battery Charger Fault *	Yellow	Green	Green or Off	Green	Off	On	On
High Battery Voltage *	Yellow	Green	Green or Off	Green	Off	On	On
Low Battery Voltage *	Yellow	Green	Green or Off	Green	Off	Off	Off
User Input #1 (RSA II) Warning	Yellow	Green	Green or Off	Green	Off	On	On
User Input #1 (RSA II) Shutdown	Red	Green	Green or Off	Green	Off	On	On
User Input #2 (RSA II) Warning	Yellow	Green	Green or Off	Green	Off	On	On
User Input #2 (RSA II) Shutdown	Red	Green	Green or Off	Green	Off	On	On
User Input #3 (RSA II) Warning	Yellow	Green	Green or Off	Green	Off	On	On
User Input #3 (RSA II) Shutdown	Red	Green	Green or Off	Green	Off	On	On
Common Fault Warning	Yellow	Green	Green or Off	Green	Red SF	On	Off
Common Fault Shutdown	Red	Green	Green or Off	Green	Red SF	On	On
ATS Position N (RSA II with ATS only)	Green	Green	Green or Off	Green	Off	Off	Off
ATS Position E (RSA II with ATS only)	Red	Red SF	Green or Off	Green	Off	Off	On
ATS Available N (RSA II with ATS only)	Green	Green	Green or Off	Green	Off	Off	Off
ATS Available E (RSA II with ATS only)	Red	Red SF	Green or Off	Green	Off	Off	On
ATS Fault (RSA II with ATS only)	Yellow	Yellow	Green or Off	Green	Off	Off	On
ATS Fault (RSA II with ATS only)	Red	Red SF	Green or Off	Green	Off	Off	On

SF = Slow Flash (1 second intervals), FF = Fast Flash (200 ms intervals)
 * May require optional kit or user-provided device to enable function and LED indication.

Figure 6-20 System Monitoring LEDs and Functions

6.1.10 Run Relay Kit

The run relay kit energizes only when the generator set runs. Use the run relay kit to control air intake and radiator louvers, alarms, and/or other signalling devices. See Figure 6-21 and Figure 6-22.

See Section 6.2, Accessory Connections, for terminal identifications.

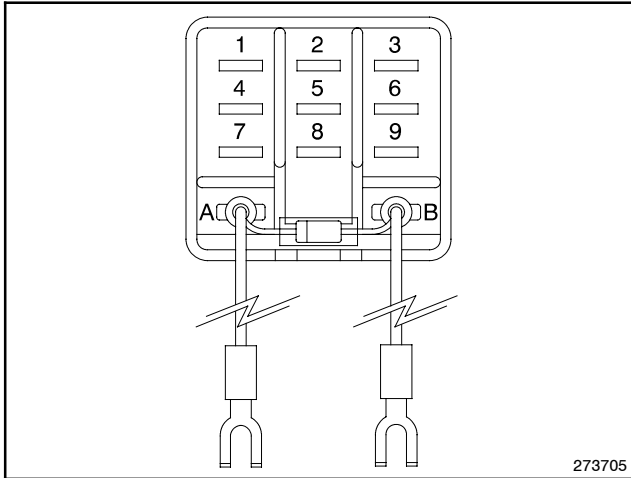

Figure 6-21 Run Relay Kit

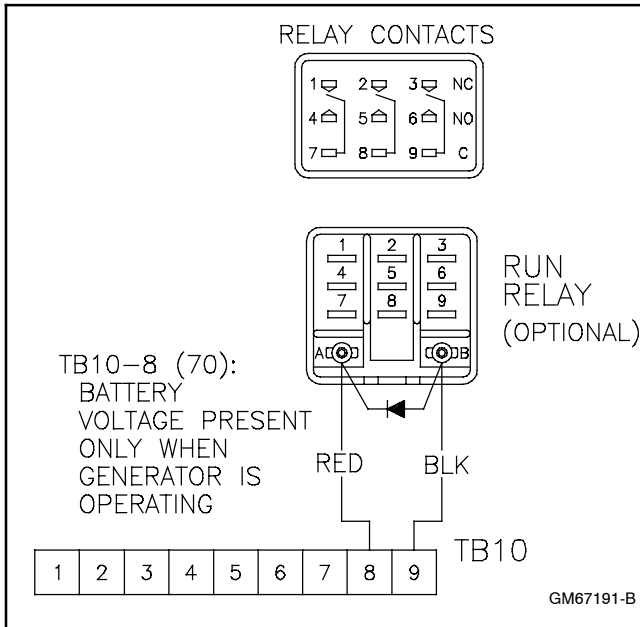

Figure 6-22 Run Relay Connections

6.1.11 Shunt-Trip Line Circuit Breaker

A shunt-trip line circuit breaker provides a 12- or 24-DC volt solenoid within the line circuit breaker case that can energize the trip mechanism. This feature allows the circuit breaker to be tripped by the common fault (32A). Connection requires a shunt-trip wiring kit and a dry contact kit. See Figure 6-23 and Figure 6-24.

The optional common fault relay shown in Figure 6-24 as DCB2 has contacts rated at 10 amps at 28 VDC or 120 VAC and is used to trigger the shunt-trip line circuit breaker kit.

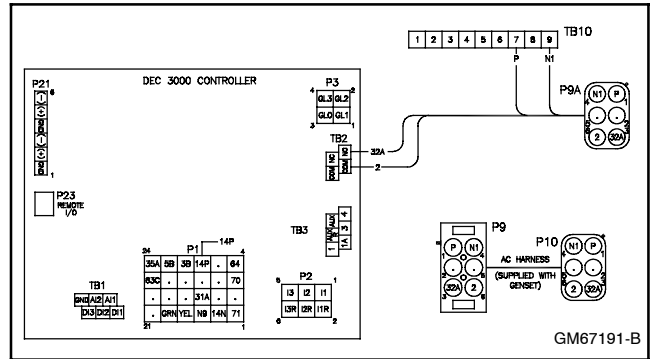

Figure 6-23 Shunt-Trip Wiring (Standard)

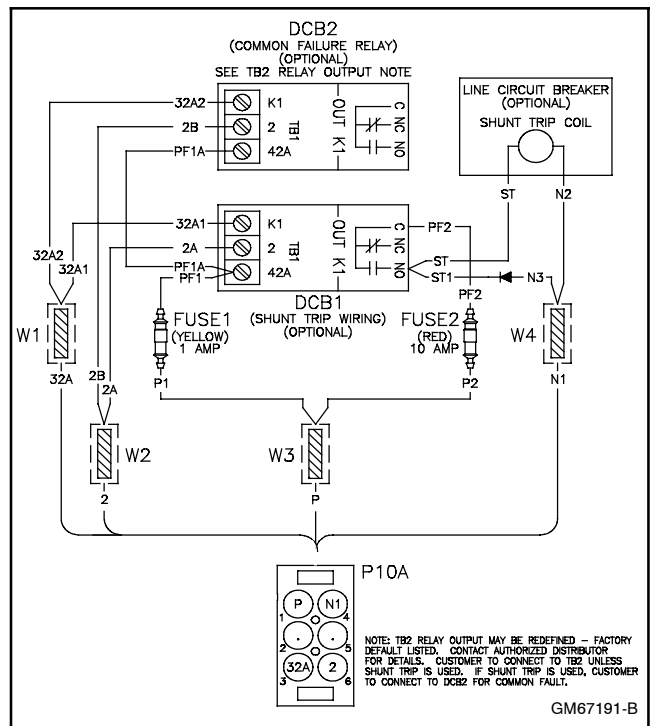

Figure 6-24 Shunt-Trip Relay Kit and Line Circuit Breaker Wiring (Shown with Common Fault/Failure Relay Kit)

6.2 Accessory Connections

The controller contains a circuit board equipped with terminal strip(s) for use in connecting external optional accessories including alarms, battery chargers, and remote switches. The optional I/O board provides an additional two analog or digital inputs and five digital outputs.

For specific information on accessory connections, refer to the accessory wiring diagrams in the wiring diagram manual and the instruction sheet accompanying the kit. See Figure 6-25, Figure 6-26, and Figure 6-28 for controller circuit board connections.

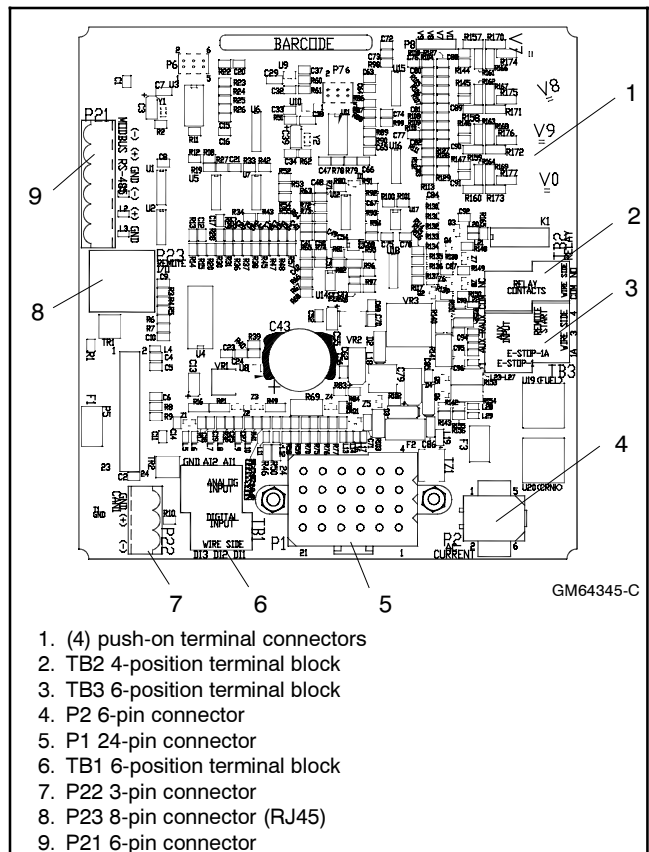

Figure 6-25 Controller Circuit Board Connections

TB1 Terminal Strip		
Analog and Digital Input Connections		
Terminal	Description	Connection
TB1-DI 1	DCH1	No Function
TB1-DI 2	DCH2	Aux. Warning Switch
TB1-DI 3	DCH3	Battery Charger Fault
TB1-AI 1	ACH1	No Function
TB1-AI 2	ACH2	No Function
TB1-GND	Ground	Common A/D Ground
TB2 Terminal Strip		
KI Relay Outputs		
Terminal	Description	Connection
TB2-COM	Common	User-Defined
TB2-COM	Common	Common Fault (2)
TB2-NO	Normally Open	Common Fault (32A)
TB2-NC	Normally Closed	User-Defined
TB3 Terminal Strip		
Accessory Power Output Connections		
Terminal	Description	Connection
TB3-1	E-Stop	E-Stop Ground
TB3-1A	E-Stop	E-Stop
TB3-3	Remote Start	Remote Start
TB3-4	Remote Start	Remote Start
TB3-AUX	Auxiliary	Aux. Shutdown Sw.
TB3-AUXR	Auxiliary-R	Aux. Shutdown Sw.

P1 24-Pin Connector		
Engine Wiring Harness		
Terminal	Description	Connection
P1-12	14P +12VDC	Prime Power Switch
P21 6-Pin Connector		
RS-485 (RSA II)		
Terminal	Description	Connection
P21-1	GND	Shield
P21-2	(+)	Red
P21-3	(-)	Black
P21-4	GND	Shield
P21-5	(+)	Red
P21-6	(-)	Black
TB1 Terminal Strip Designations		
Analog and Digital Input Connections		
Terminals on Board	Controller Designation	SiteTech Designation
TB1-DI 1	DIn A1	A1
TB1-DI 2	DIn A2	A2
TB1-DI 3	DIn A3	A3
TB1-AI 1	AIn A1	—
TB1-AI 2	AIn A2	A1
TB1-GND	—	—

Figure 6-26 Controller Connections

P25 Connector	
RJ45 Remote I/O In	
Connects to DEC 3000 P23	
P26 Connector	
RJ45 Remote I/O Out	
Open	
P27 Connector	
CAN Terminator	
Place the P27 jumper on the IN pins	
P28 Connector	
Single-Ended (0-5 V) Analog Input Connections	
Terminal	Description
P28-GND	AGND Analog Return
P28-VN1	NO Connection
P28-VP1	ACH1 Signal
P28-+5V	Supply (.05 amp max.)
P28-GND	AGND Analog Return
P28-VN2	NO Connection
P28-VP2	ACH2 Signal
P28-+5V	Supply (0.05 amp max.)
P28 Connector	
Differential (+/-3 V) Analog Input Connections	
Terminal	Description
P28-GND	AGND Analog Reference
P28-VN1	ACH1 Negative Differential Signal
P28-VP1	ACH1 Positive Differential Signal
P28-+5V	Supply (.05 amp max.)
P28-GND	AGND Analog Reference
P28-VN2	ACH2 Negative Differential Signal
P28-VP2	ACH2 Positive Differential Signal
P28-+5V	Supply (0.05 amp max.)
P29 Connector	
2 Amp. K1 Relay Output (2.1) Connections	
Terminal	Description
P29-NC	Normally Closed
P29-COM	Common
P29-NO	Normally Open

P30 Connector	
2 Amp. K2 Relay Output (2.2) Connections	
Terminal	Description
P30-NC	Normally Closed
P30-COM	Common
P30-NO	Normally Open
P31 Connector	
2 Amp. K3 Relay Output (2.3) Connections	
Terminal	Description
P31-NC	Normally Closed
P31-COM	Common
P31-NO	Normally Open
P32 Connector	
10 Amp. K4 Relay Output (2.4) Connections	
Terminal	Description
P32-NC	Normally Closed
P32-COM	Common
P32-NO	Normally Open
10 Amp. K5 Relay Output (2.5) Connections	
Terminal	Description
P32-NC	Normally Closed
P32-COM	Common
P32-NO	Normally Open

P28 Connector Designations		
Terminals on Board	Controller Designation	SiteTech Designation
P28-GND	DIn B1	B1
P28-VN1		
P28-VP1		
P28-+5V		
P28-GND	Din B2	B2
P28-VN2		
P28-VP2		
P28-+5V		

Figure 6-27 Input/Output Module Board Connections

Appendix A Abbreviations

The following list contains abbreviations that may appear in this publication.

A, amp	ampere	cfm	cubic feet per minute	exh.	exhaust
ABDC	after bottom dead center	CG	center of gravity	ext.	external
AC	alternating current	CID	cubic inch displacement	F	Fahrenheit, female
A/D	analog to digital	CL	centerline	FHM	flat head machine (screw)
ADC	advanced digital control; analog to digital converter	cm	centimeter	fl. oz.	fluid ounce
adj.	adjust, adjustment	CMOS	complementary metal oxide substrate (semiconductor)	flex.	flexible
ADV	advertising dimensional drawing	com	communications (port)	freq.	frequency
Ah	amp-hour	coml	commercial	FS	full scale
AHWT	anticipatory high water temperature	Coml/Rec	Commercial/Recreational connection	ft.	foot, feet
AISI	American Iron and Steel Institute	conn.	connection	ft. lb.	foot pounds (torque)
ALOP	anticipatory low oil pressure	cont.	continued	ft./min.	feet per minute
alt.	alternator	CPVC	chlorinated polyvinyl chloride	ftp	file transfer protocol
Al	aluminum	crit.	critical	g	gram
ANSI	American National Standards Institute (formerly American Standards Association, ASA)	CSA	Canadian Standards Association	ga.	gauge (meters, wire size)
AO	anticipatory only	CT	current transformer	gal.	gallon
APDC	Air Pollution Control District	Cu	copper	gen.	generator
API	American Petroleum Institute	cUL	Canadian Underwriter's Laboratories	genset	generator set
approx.	approximate, approximately	CUL	Canadian Underwriter's Laboratories	GFI	ground fault interrupter
APU	Auxiliary Power Unit	cu. in.	cubic inch	GND, ⊕	ground
AQMD	Air Quality Management District	cw.	clockwise	gov.	governor
AR	as required, as requested	CWC	city water-cooled	gph	gallons per hour
AS	as supplied, as stated, as suggested	cyl.	cylinder	gpm	gallons per minute
ASE	American Society of Engineers	D/A	digital to analog	gr.	grade, gross
ASME	American Society of Mechanical Engineers	DAC	digital to analog converter	GRD	equipment ground
assy.	assembly	dB	decibel	gr. wt.	gross weight
ASTM	American Society for Testing Materials	dB(A)	decibel (A weighted)	H x W x D	height by width by depth
ATDC	after top dead center	DC	direct current	HC	hex cap
ATS	automatic transfer switch	DCR	direct current resistance	HCHT	high cylinder head temperature
auto.	automatic	deg., °	degree	HD	heavy duty
aux.	auxiliary	dept.	department	HET	high exhaust temp., high engine temp.
avg.	average	dia.	diameter	hex	hexagon
AVR	automatic voltage regulator	DI/EO	dual inlet/end outlet	Hg	mercury (element)
AWG	American Wire Gauge	DIN	Deutsches Institut für Normung e. V. (also Deutsche Industrie Normenausschuss)	HH	hex head
AWM	appliance wiring material	DIP	dual inline package	HHC	hex head cap
bat.	battery	DPDT	double-pole, double-throw	HP	horsepower
BBDC	before bottom dead center	DPST	double-pole, single-throw	hr.	hour
BC	battery charger, battery charging	DS	disconnect switch	HS	heat shrink
BCA	battery charging alternator	DVR	digital voltage regulator	hsg.	housing
BCI	Battery Council International	E ² PROM, EEPROM	electrically-erasable programmable read-only memory	HVAC	heating, ventilation, and air conditioning
BDC	before dead center	E, emer.	emergency (power source)	HWT	high water temperature
BHP	brake horsepower	ECM	electronic control module, engine control module	Hz	hertz (cycles per second)
blk.	black (paint color), block (engine)	EDI	electronic data interchange	IBC	International Building Code
blk. htr.	block heater	EFR	emergency frequency relay	IC	integrated circuit
BMEP	brake mean effective pressure	e.g.	for example (<i>exempli gratia</i>)	ID	inside diameter, identification
bps	bits per second	EG	electronic governor	IEC	International Electrotechnical Commission
br.	brass	EGSA	Electrical Generating Systems Association	IEEE	Institute of Electrical and Electronics Engineers
BTDC	before top dead center	EIA	Electronic Industries Association	IMS	improved motor starting
Btu	British thermal unit	EI/EO	end inlet/end outlet	in.	inch
Btu/min.	British thermal units per minute	EMI	electromagnetic interference	in. H ₂ O	inches of water
C	Celsius, centigrade	emiss.	emission	in. Hg	inches of mercury
cal.	calorie	eng.	engine	in. lb.	inch pounds
CAN	controller area network	EPA	Environmental Protection Agency	Inc.	incorporated
CARB	California Air Resources Board	EPS	emergency power system	ind.	industrial
CAT5	Category 5 (network cable)	ER	emergency relay	int.	internal
CB	circuit breaker	ES	engineering special, engineered special	int./ext.	internal/external
CC	crank cycle	ESD	electrostatic discharge	I/O	input/output
cc	cubic centimeter	est.	estimated	IP	internet protocol
CCA	cold cranking amps	E-Stop	emergency stop	ISO	International Organization for Standardization
ccw.	counterclockwise	etc.	et cetera (and so forth)	J	joule
CEC	Canadian Electrical Code			JIS	Japanese Industry Standard
cert.	certificate, certification, certified			k	kilo (1000)
cfh	cubic feet per hour			K	kelvin
				kA	kiloampere
				KB	kilobyte (2 ¹⁰ bytes)
				KBus	Kohler communication protocol
				kg	kilogram

kg/cm ²	kilograms per square centimeter	NBS	National Bureau of Standards	RTU	remote terminal unit
kgm	kilogram-meter	NC	normally closed	RTV	room temperature vulcanization
kg/m ³	kilograms per cubic meter	NEC	National Electrical Code	RW	read/write
kHz	kilohertz	NEMA	National Electrical Manufacturers Association	SAE	Society of Automotive Engineers
kJ	kilojoule	NFPA	National Fire Protection Association	scfm	standard cubic feet per minute
km	kilometer	Nm	newton meter	SCR	silicon controlled rectifier
kOhm, kΩ	kilo-ohm	NO	normally open	s, sec.	second
kPa	kilopascal	no., nos.	number, numbers	SI	<i>Système international d'unités</i> , International System of Units
kph	kilometers per hour	NPS	National Pipe, Straight	SI/EO	side in/end out
kV	kilovolt	NPSC	National Pipe, Straight-coupling	sil.	silencer
kVA	kilovolt ampere	NPT	National Standard taper pipe thread per general use	SMTP	simple mail transfer protocol
kVAR	kilovolt ampere reactive	NPTF	National Pipe, Taper-Fine	SN	serial number
kW	kilowatt	NR	not required, normal relay	SNMP	simple network management protocol
kWh	kilowatt-hour	ns	nanosecond	SPDT	single-pole, double-throw
kWm	kilowatt mechanical	OC	overcrank	SPST	single-pole, single-throw
kWth	kilowatt-thermal	OD	outside diameter	spec	specification
L	liter	OEM	original equipment manufacturer	specs	specification(s)
LAN	local area network	OF	overfrequency	sq.	square
L x W x H	length by width by height	opt.	option, optional	sq. cm	square centimeter
lb.	pound, pounds	OS	oversize, overspeed	sq. in.	square inch
lbm/ft ³	pounds mass per cubic feet	OSHA	Occupational Safety and Health Administration	SMS	short message service
LCB	line circuit breaker	OV	overvoltage	SS	stainless steel
LCD	liquid crystal display	oz.	ounce	std.	standard
LED	light emitting diode	p., pp.	page, pages	stl.	steel
Lph	liters per hour	PC	personal computer	tach.	tachometer
Lpm	liters per minute	PCB	printed circuit board	TB	terminal block
LOP	low oil pressure	pF	picofarad	TCP	transmission control protocol
LP	liquefied petroleum	PF	power factor	TD	time delay
LPG	liquefied petroleum gas	ph., ∅	phase	TDC	top dead center
LS	left side	PHC	Phillips® head Crimptite® (screw)	TDEC	time delay engine cooldown
L _{wa}	sound power level, A weighted	PHH	Phillips® hex head (screw)	TDEN	time delay emergency to normal
LWL	low water level	PHM	pan head machine (screw)	TDES	time delay engine start
LWT	low water temperature	PLC	programmable logic control	TDNE	time delay normal to emergency
m	meter, milli (1/1000)	PLG	programmable logic control	TDOE	time delay off to emergency
M	mega (10 ⁶ when used with SI units), male	PMG	permanent magnet generator	TDON	time delay off to normal
m ³	cubic meter	pot	potentiometer, potential	temp.	temperature
m ³ /hr.	cubic meters per hour	ppm	parts per million	term.	terminal
m ³ /min.	cubic meters per minute	PROM	programmable read-only memory	THD	total harmonic distortion
mA	milliampere	psi	pounds per square inch	TIF	telephone influence factor
man.	manual	psig	pounds per square inch gauge	tol.	tolerance
max.	maximum	pt.	pint	turbo.	turbocharger
MB	megabyte (2 ²⁰ bytes)	PTC	positive temperature coefficient	typ.	typical (same in multiple locations)
MCCB	molded-case circuit breaker	PTO	power takeoff	UF	underfrequency
MCM	one thousand circular mils	PVC	polyvinyl chloride	UHF	ultrahigh frequency
meggar	megohmmeter	qt.	quart, quarts	UIF	user interface
MHz	megahertz	qty.	quantity	UL	Underwriter's Laboratories, Inc.
mi.	mile	R	replacement (emergency)	UNC	unified coarse thread (was NC)
mil	one one-thousandth of an inch	rad.	radiator, radius	UNF	unified fine thread (was NF)
min.	minimum, minute	RAM	random access memory	univ.	universal
misc.	miscellaneous	RDO	relay driver output	URL	uniform resource locator (web address)
MJ	megajoule	ref.	reference	US	undersize, underspeed
mJ	millijoule	rem.	remote	UV	ultraviolet, undervoltage
mm	millimeter	Res/Coml	Residential/Commercial	V	volt
mOhm, mΩ	milliohm	RFI	radio frequency interference	VAC	volts alternating current
MOhm, MΩ	megohm	RH	round head	VAR	voltampere reactive
MOV	metal oxide varistor	RHM	round head machine (screw)	VDC	volts direct current
MPa	megapascal	rly.	relay	VFD	vacuum fluorescent display
mpg	miles per gallon	rms	root mean square	VGA	video graphics adapter
mph	miles per hour	rnd.	round	VHF	very high frequency
MS	military standard	RO	read only	W	watt
ms	millisecond	ROM	read only memory	WCR	withstand and closing rating
m/sec.	meters per second	rot.	rotate, rotating	w/	with
mtg.	mounting	rpm	revolutions per minute	WO	write only
MTU	Motoren-und Turbinen-Union	RS	right side	w/o	without
MW	megawatt	RTDs	Resistance Temperature Detectors	wt.	weight
mW	milliwatt			xfrm	transformer
μF	microfarad				
N, norm.	normal (power source)				
NA	not available, not applicable				
nat. gas	natural gas				

Appendix B Programmer-Defined Settings

Use the table below to record programmer-defined settings during the generator set controller setup and calibration. The controller default settings and ranges provide guidelines. The table contains all faults with ranges and time delays including items that do not have adjustments. Some notices give the programmer a choice to make them active. Not adjustable programmer-defined settings result when the controller logic does not allow changes or the values are engine limited.

SiteTech™ setup software is required for programming the Decision-Maker® 3000 controller. Contact your local distributor/dealer for assistance.

Note: Inhibit time delay is the time delay period after crank disconnect.

Note: The engine ECM may limit the crank cycle even if the controller is set to a longer time period.

Programmer-Defined Settings

Description	Controller Display Message	Write Access Display SiteTech	GenSet Mode Always Running Stopped	Range Setting	Default Selection	Time Delay Range (sec.)	Default Time Delay (sec.)	Programmer-Defined Settings
Engine Functions								
Critically high fuel level (diesel-powered models only) *	Fuel Level Critically High			0-100%	95%	0-10	5	
ECM communications loss	ECM Comm Err Shutdwn					Fixed	10	Not adjustable
ECM diagnostics (multiple inputs) †	ECM xxxxxx Warning							Not adjustable
ECM diagnostics (multiple inputs) †	ECM xxxxxx Shutdwn							Not adjustable
ECM faults (address conflict)	ECM Addr Err Shutdwn							Not adjustable
ECM faults (model mismatch)	ECM Mismatch Shutdwn			0-255	0			
Engine over speed	Eng Speed High Shutdwn	S	A	105-120%	115%			
Engine start aid active	Starting Aid Notice							
Engine under speed	Eng Speed Low Shutdwn	S	A	75-95%	85%			
Fuel tank leak *	Fuel Leak Warning							Not adjustable
Fuel tank leak *	Fuel Leak Shutdwn							Not adjustable
High battery voltage	Battery High Warning	S	A	110-135%	125%	Fixed	10	Not adjustable
High coolant temperature	Coolnt Temp High Warning					0-10 (0-30 inhibit)	0 (0 inhibit)	
High coolant temperature	Coolnt Temp High Shutdwn					0-10 (0-30 inhibit)	0 (0 inhibit)	
High fuel level (diesel-powered models only) *	Fuel Level High Warning			0-100%	90%	0-10	5	
Low battery voltage	Battery Low Warning	S	A	80-105%	100%	Fixed	90	Not adjustable
Low coolant level *	Coolant Lvl Low Shutdwn					Fixed	5	Not adjustable
Low coolant temperature	Coolant Temp Low Warning			Fixed	16°C (60°F)	0-10 (0-30 inhibit)	5 (0 inhibit)	
Low cranking voltage	Lo Crank Vlt Warning			Fixed	60%	Fixed	6	Not adjustable
Low engine oil level *	Oil Level Low Warning							Not adjustable
Low engine oil level *	Oil Level Low Shutdwn							Not adjustable
Low fuel level (diesel models) *	Fuel Level Low Warning			0-100%	35%	0-10	10	
Low fuel level (diesel models) *	Fuel Level Low Shutdwn			0-100%	5%	0-10	0	

Description	Controller Display Message	Write Access Display SiteTech	GenSet Mode Always Running Stopped	Range Setting	Default Selection	Time Delay Range (sec.)	Default Time Delay (sec.)	Programmer-Defined Settings
Low fuel pressure (gas models) *	Fuel Press Low Warning							Not adjustable
Low oil pressure	Oil Press Low Warning					Fixed (Fixed inhibit)	0 (30 inhibit)	Not adjustable
Low oil pressure	Oil Press Low Shutdwn					Fixed (Fixed inhibit)	5 (30 inhibit)	Not adjustable
No coolant temperature signal	Temp Sig Loss Shutdwn							Not adjustable
No oil pressure signal	Press Sig Loss Shutdwn					Fixed	5	Not adjustable
Overcrank	Over Crank Shutdwn					Fixed	(30 inhibit)	Not adjustable
Speed sensor fault	Spd Sens Flt Warning							Not adjustable
General Functions								
Alarm silence, 0-Auto only (NFPA 110), 1-Always	AlarmSilenceMode	S	A	0-1	1			
Aux. inputs 0-5 VDC, 1 analog	Aux Input Warning			0-100%	100%	0-10	0	
Aux. inputs 0-5 VDC, 1 analog	Aux Input Shutdwn			0-100%	100%	0-10	0	
Auxiliary inputs, up to 3 digital (2 additional digital inputs available with I/O module option)	Aux Input Warning					0-10 (0-30 inhibit)	0 (0 inhibit)	
Auxiliary inputs, up to 3 digital (2 additional digital inputs available with I/O module option)	Aux Input Shutdwn					0-10 (0-30 inhibit)	0 (0 inhibit)	
Backup parameters loaded	Backup Pars Status							Not adjustable
Battery charger fault *	Batt Chg Flt Warning							Not adjustable
Chicago code active *	Auto Locked Notice							
Common fault	Common Fault Shutdwn							Not adjustable
Common warning	Common Warng							Not adjustable
Default parameters loaded	Default Pars Warning							Not adjustable
Emergency stop	Emerg Stop Shutdwn							Not adjustable
Engine cooldown (delay) active	Eng Cooldown Notice							
Engine start delay active	Start Delay Notice							
Engine started	Engine Start Status							Not adjustable
Engine stopped	Engine Stop Status							Not adjustable
EPS supplying load	Emerg Pwr On Notice							Not adjustable
File system error (controller fault)	File Error Shutdwn							Not adjustable
Generator running	Gen Running Notice							Not adjustable
Input/output (optional module board) communication loss	OB1 Com Loss							Not adjustable
Internal failure	Intern Error Shutdwn							Not adjustable
Measurement Units, 0-English, 1-Metric	Measurement Display	DS	A	0-1	1			
Metering communication loss	MeterCommLos Shutdwn							Not adjustable
NFPA 110 alarm active	NFPA Alarm Notice							
Not in auto (master control buttons)	Not In Auto Warning							Not adjustable
Prime power application, 0-Standby, 1-Prime	Power Type	DS	A	0-1	0			
Remote start	Remote Start Status							Not adjustable

Description	Controller Display Message	Write Access Display SiteTech	GenSet Mode Always Running Stopped	Range Setting	Default Selection	Time Delay Range (sec.)	Default Time Delay (sec.)	Programmer-Defined Settings
System ready	System Ready Status							Not adjustable
System timer failed	Timer Error Notice							Not adjustable
Generator Functions								
AC sensing loss	AC Sens Loss Warning							Not adjustable
AC sensing loss	AC Sens Loss Shutdwn					Fixed	3	Not adjustable
Alternator protection	Alt Protect Shutdwn							Not adjustable
Ground fault input *	Ground Fault Warning							Not adjustable
kW overload	Total Power High Shutdwn			Fixed	102% standby, 112% prime	Fixed	60	Not adjustable
Locked rotor (failed to crank)	Locked Rotor Shutdwn	S	A			1-5	5	
Overfrequency	Freq High Shutdwn			102-140%	110%	Fixed	10	Not adjustable
Overvoltage (each phase)	Volts (L1-L2, L2-L3, or L3-L1) High Shutdwn	S	A	105-135%	120%	2-10	2	
Power rating	Pwr Rating	DS	S	10-5000	275			
System frequency	System Freq	DS	S	50-60	60			
System voltage	System Volt	DS	S	110-600	208			
Underfrequency	Frequency Low Shutdwn			80-95%	90%	Fixed	10 ST 60 LT	Not adjustable
Undervoltage (each phase)	Volts (L1-L2, L2-L3, or L3-L1) Low Shutdwn	S	A	70-95%	80%	5-30	10	
Voltage/phase configuration, 0-Single phase, 1-Single phase dogleg, 2-three phase wye, 3-three phase delta	SystemPhase	DS	S	0-3	2			
Voltage regulator average voltage adjustment	VR Volt Adj	DS	R	108-600	208			
(Voltage) regulator communication loss	RegCommLoss Shutdwn							Not adjustable
SiteTech Read/Write Display Only								
Current transformer ratio ‡		S	S	1-	1200			
ECM power		S	S	0-1	0			
Engine cooldown delay		S	A			0-600	300	
Engine (cyclic) crank on		S	A			10-30	15	
Engine (cyclic) crank pause		S	A			1-60	15	
Engine ECM start delay		S	A			0-300	0	
Engine idle duration		S	A			0-60	60	
Engine no. of (cyclic) crank cycles		S	S	1-6	3			
Engine restart delay		S	A			1-10	10	
Engine start aid delay		S	A			0-10	0	
Engine start delay		S	A			0-300	0	
System battery voltage ‡		S	S	12-24	12			
Voltage regulator gain		S	R	1-255	128			
Voltage regulator stability adjust		S	R	1-255	128			
Voltage regulator, volts per Hertz slope		S	R	1-10	5			
Voltage regulator, volts per Hertz cutin frequency		S	R	42-62	57.5			

* Some functions require optional input sensors or are engine ECM dependent on some generator set models.

† ECM inputs are engine manufacturer dependent.

‡ Changeable only by resetting the controller with a personality profile (SiteTech 1.4 or higher).

ST-Short Term, LT-Long Term

Notes

Appendix C Voltage Regulator Definitions and Adjustments

The following definitions and adjustment/setting specifications are intended for users planning to adjust the voltage regulator beyond the default settings in order to customize the alternator for a specific application.

This information is not intended to be a comprehensive explanation of all the terms mentioned. There are numerous documents available that define these terms more completely than described herein. Any user planning to change the generator set controller adjustment settings or to apply the generator set to these types of applications should understand these terms.

This appendix contains references to other sections of this manual. Please refer to these sections for further information and explanation.

Paralleling generator sets can be a complicated and dangerous exercise. Application programming must be performed by appropriately skilled and suitably-trained personnel.

Definitions

Underfrequency Unloading

Underfrequency unloading is a function used in the alternator excitation control system to improve the overall generator set system (engine and alternator) response. In particular, underfrequency unloading relates to large-block load applications. When applied to engine-driven alternators, large-block loads cause a subsequent transient torque load on the engine. This torque load can reduce the engine's speed below the normal operating point. Typically, the engine speed controller or governor will compensate for this by commanding an increase in fuel. If, however, the fuel system is inadequate to recover from a relatively large load, the speed may never recover. In these instances, other measures must be taken. This is where the underfrequency unloading occurs.

When the excitation control system detects a drop in the speed or electrical frequency below some predetermined point, the control system enters an unloading condition. This can be described as moving to a lower voltage regulation point. By reducing the output voltage of the alternator, the load on the generator set is reduced. This can be shown

mathematically by Ohm's law, which states that power is equal to the voltage squared divided by the impedance. As the voltage is reduced, the power delivered by the alternator decreases by a squared relationship. Since it is the power in the alternator that translates into engine torque, the engine load is also reduced.

By changing various parameters of this compensation technique, the controlling system can be tailored to match the performance capabilities of most engine and alternator combinations. The point at which the unloading begins to act or how much unloading occurs can be adjusted to impact maximum voltage droop, maximum speed droop, or time to recover. Some applications may not need unloading and, in these cases, set the unloading parameter to disable the function. These parameters are further described below. An example is provided to help clarify the relationship between these parameters.

Underfrequency Unload Slope

Underfrequency unload slope is the term used to describe the amount that the voltage is reduced, per-cycle-per-second or per-hertz (Hz), when in an underfrequency condition. The slope or schedule is sometimes called the volts-per-hertz slope. When the electrical frequency drops below the cut-in point (see below), the excitation control system temporarily reduces the regulated voltage to reduce the subsequent torque on the engine. The amount that the control system reduces voltage is defined as the product or multiplication of the slope and the amount of frequency or speed below the cut-in point. For every Hz below the cut-in point, the control system reduces the line-to-line voltage by an amount equal to the slope.

Because each engine responds differently to the various loads encountered, the slope may be adjusted to improve the system response. If, when large loads are applied to the generator set, the engine speed drops below the acceptable limit (as determined by the particular loads applied), the slope may need to be increased. Increasing the slope will cause the voltage to droop more during load applications, consequently reducing the load torque on the engine and allowing the speed to increase. If, however, the voltage drops below an acceptable lower limit (as determined by the particular loads connected to the generator set), a lower slope may work better. The underfrequency unloading function may be disabled by setting the slope to zero.

Frequency Setpoint or Cut-In Point

The point at which the underfrequency unloading begins to take effect is adjustable, allowing the system to be tailored for each application. Because the characteristics of the engine have the largest effect on the system's performance, the engine's response should determine the unloading point. The unloading setpoint is the frequency below which the excitation control will reduce the voltage so that the engine may begin to recover.

The cut-in point, or frequency setpoint, should be set 0.5–3.0 Hz lower than the normal steady-state band of operation. If the engine normally operates within a very narrow range of speeds close to the nominal, a setpoint of 0.5 to 1.0 Hz below nominal should be suitable. If the engine normally operates over a wide range of speeds, the setpoint may need to be 2.0–3.0 Hz from the nominal. The underfrequency unloading function can be eliminated by setting the cut-in point below the minimum expected operating frequency.

Example

A 90 kW load is applied to a 100 kW, 60 Hz generator set driven by a turbocharged diesel engine with an electronic control module (ECM). The speed drops 10% and takes 20 seconds to recover to at least 59.5 Hz. The voltage, meanwhile, drops from 480 to 460 and recovers to 480 within 15 seconds. Therefore, some underfrequency unloading should be provided. A good starting point would be a frequency setpoint or cut-in of 59 Hz. A slope of 15 volts per-cycle-per-second is appropriate as well. If after these adjustments the speed recovers very quickly, in about 5 seconds, but the voltage drops below 440 volts, the slope should be reduced to 12 volts per cycle. More adjusting may be required to get the most desirable compromise between speed and voltage.

Three-Phase Sensing

Three-phase sensing describes how the excitation control or voltage regulator determines the condition of the alternator output voltage. Early types of regulators sensed the voltage on just one phase of the alternator. Single-phase sensing is not uncommon today as most alternators are designed to produce balanced, equal voltage on all three phases. If the loads applied to the generator set including no load are equal and balanced, the output voltage on each phase will be nearly equal.

However, in some applications, individual phases may have unequal or unbalanced loads. In these cases, the output voltages will not be equal on each phase. In

general, the phase with the greatest load will have the lowest voltage while the phase with the least load will have the highest voltage. This is true regardless of the type of sensing used in the regulator system. A single-phase sensing excitation controller will keep the voltage of the sensed phase at the voltage adjustment value. A three-phase sensing system will average the three phases and hold the average to the adjustment setting. The average is the sum of the voltages of three phases divided by 3.

As stated above, three-phase sensing does not eliminate the unequal voltage phenomenon. Three-phase sensing balances the inequality of voltage between the phases to the desired value. In other words, if a system with unbalanced loads uses a single-phase control feedback, the voltage on the sensed phase would be at the setpoint while the other two phases would vary by their proportional loads. For example, if the sensed phase had rated load while the two other phases were only loaded at half the rated value, those two phases would have higher-than-rated voltage which may be undesirable. If a three-phase sensing feedback were utilized, the phase with rated load would be regulated to a voltage slightly below the rated voltage while the other two phases would be slightly above the rated voltage (but lower than in the previous case). The sum of the three, divided by 3, would be equal to the regulation setpoint.

In a single-phase system, line-to-line voltage is held equal to the line-to-line voltage adjust setting. In a three-phase system, the average of the three line-to-line voltage is regulated to the voltage adjust setting. In some cases, it may be desirable to keep one phase at a particular value. Modify the voltage adjust setting higher or lower accordingly for any unique requirements for the particular application.

Adjustment and Setting Specifications

Voltage Adjust

The voltage adjust is entered as the rated or otherwise desired line-to-line voltage. The average of the line-to-line voltages is then regulated to the corresponding value as previously described. The setting may be as fine as tenths of volts. The voltage adjust defaults to the rated system voltage whenever the system voltage is changed. The voltage adjust may be set to any value within $\pm 10\%$ of the system voltage. The upper limit is $\pm 10\%$ above the system voltage and the lower limit is $\pm 10\%$ below the system voltage.

As a reference, the present voltage adjust setting is displayed as well as the average value of the line-to-line voltages. The individual line-to-line voltages are also displayed on the subsequent menu screens. This allows the user to monitor any individual phase, if desired.

The voltage adjust setting may be changed by means other than the menu including user-defined digital input or remote communications. If voltage adjustment occurs, the new value will be displayed accordingly in the voltage adjust menu.

Underfrequency Unload Enable

The underfrequency unload enable menu is used to turn the underfrequency unload on or off. A YES entry will turn the feature on and the display will show ENABLED YES. A NO entry will turn the feature off and the display will show ENABLED NO. The underfrequency unload defaults to an enabled (ON) condition.

Frequency Setpoint

The frequency setpoint is the cut-in point for underfrequency unloading. At any operating frequency below the frequency setpoint, the output voltage will be reduced. The frequency may be entered with resolution to tenths of a Hz. The range of acceptable entries is 30 to 70 Hz. The default value is one cycle-per-second (or two for non-ECM engines) below the normal system frequency. The frequency setpoint changes to the default value if the system frequency changes. A setting of 30 Hz essentially disables the underfrequency unload feature because most engines do not normally drop to speeds this low, even during load applications.

Underfrequency Unload Slope

The slope determines how much voltage is reduced during an unloading condition. The line-to-line voltage is regulated to a value less than the voltage adjust setting by this amount for every cycle below the frequency setpoint. The voltage may be entered with resolution as fine as one-tenth of one volt. The default value is 2.0 volts per-cycle-per-second. A zero entry for the slope in effect turns the underfrequency unload feature off.

Notes

Appendix D Alternator Protection

The controller has built-in thermal protection for the alternator. This feature functions similarly to a thermal circuit breaker. When the output current exceeds the nominal rating for a short period of time the condition causes the fault shutdown. The amount of time at which current is over the rating is inversely related to the amount of current above the nominal rating. In other words, the higher the current, the shorter the acceptable time.

The current and time limits are defined by actual test data and are maintained in the personality parameter file. Although the equation for detecting a fault is proprietary, some of the important limits are shown below for informational purposes.

Rated Current	Time Delay
200%	40 seconds
300%	10 seconds
425%	5 seconds
950%	1 second

Notes

Notes

Notes

TP-6694 7/11c

© 2010, 2011 by Kohler Co. All rights reserved.

KOHLER[®] POWER SYSTEMS

KOHLER CO. Kohler, Wisconsin 53044
Phone 920-457-4441, Fax 920-459-1646
For the nearest sales/service outlet in the
US and Canada, phone 1-800-544-2444
KohlerPower.com

Kohler Power Systems
Asia Pacific Headquarters
7 Jurong Pier Road
Singapore 619159
Phone (65) 6264-6422, Fax (65) 6264-6455