



Technical catalogue

Emax

Low voltage air circuit-breakers



Main characteristics

Ranges

Installations

**Overcurrent releases
and relative accessories**

Accessories

Circuit-breakers applications

Overall dimensions

Electrical circuit diagrams

Ordering codes

1

2

3

4

5

6

7

8

9

New Emax.
The evolution continues.



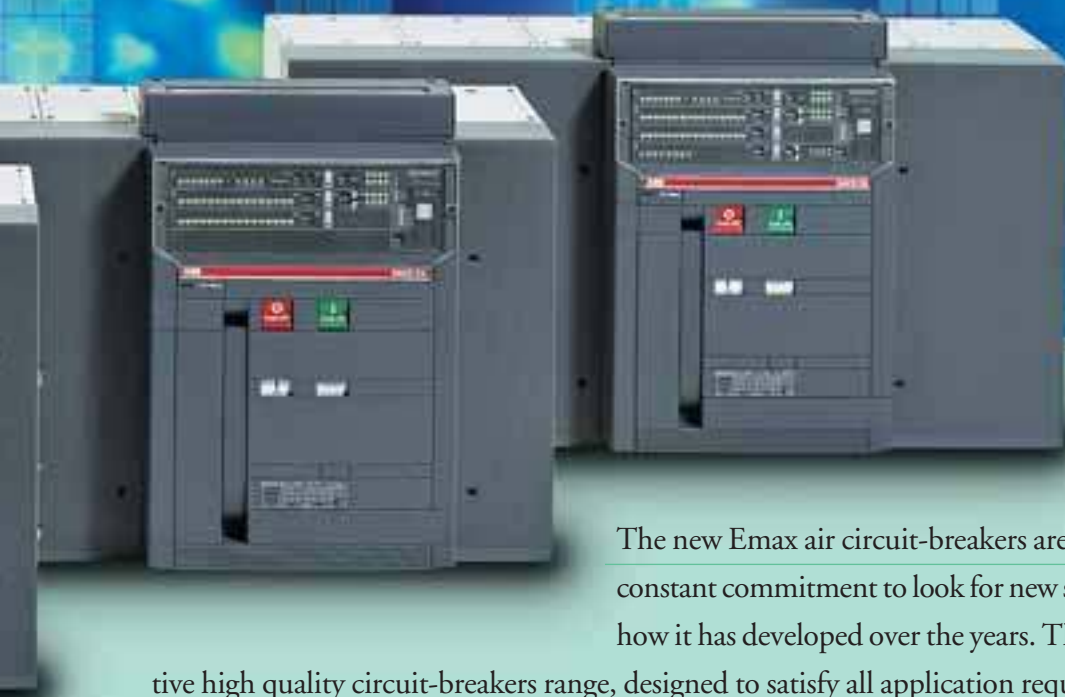

The new Emax air circuit-breakers are the result of ABB SACE's constant commitment to look for new solutions, and of the know-how it has developed over the years. This is an incredibly innovative

high quality circuit-breakers range, designed to satisfy all application requirements. The innovation of the new Emax is really outstanding from all points of view: completely re-engineered releases fitted with latest generation electronics, improved performances with the same dimensions and new applications to fulfil the latest market needs. The new electronics open a window on a world of extraordinary solutions, with connectivity options never before seen in the market. Discover the great advantages of ABB SACE's new Emax. The evolution has been going on since 1942.

New Emax.
Lively performances.





Continuing the tradition of ABB SACE, the new Emax range offers performances at the top of its category. The Emax range offers you a great advantage: with the increased performances, you can use the smaller circuit-breaker frames, obtaining considerable savings both in economic terms and in physical space within the switchgear. Emax E1 now offers current ratings up to 1600A, whilst Emax E3 is enhanced by version V with top of the range performances. Always aware of the rapid changes in the market, ABB SACE has made some specific versions to cover new applications and simplify retrofitting operations.



New Emax. Brilliant intelligence.



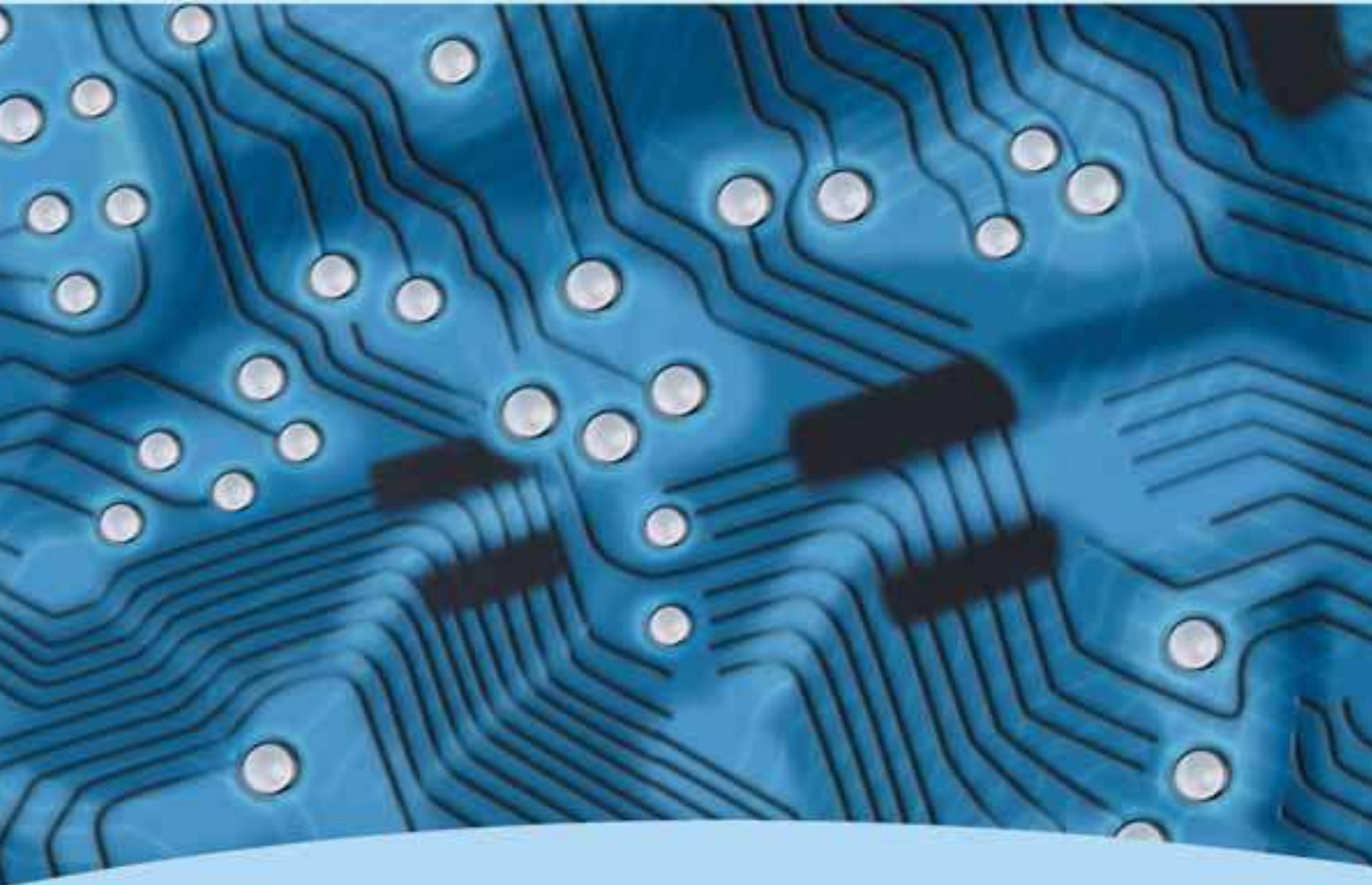

The new Emax range shines like a light from within: the new generation of protection trip units is fitted with the latest advances in electronics, offering individual bespoke solutions for control and protection. The new trip units, which are amazingly versatile and simple to use, offer important innovations, such as the brand-new intuitive operator interface allowing complete control of the system with just a few simple key-strokes. Furthermore, there are new protections, new alarms and connection to handheld and laptop PCs using Bluetooth technology. The re-engineered hardware architecture allows flexible and precise configuration. With the new Emax it is no longer necessary to completely replace the trip unit - simply add the module which satisfies your requirements: a great advantage, both in terms of flexibility and customisation.



New Emax. Ensured reliability.

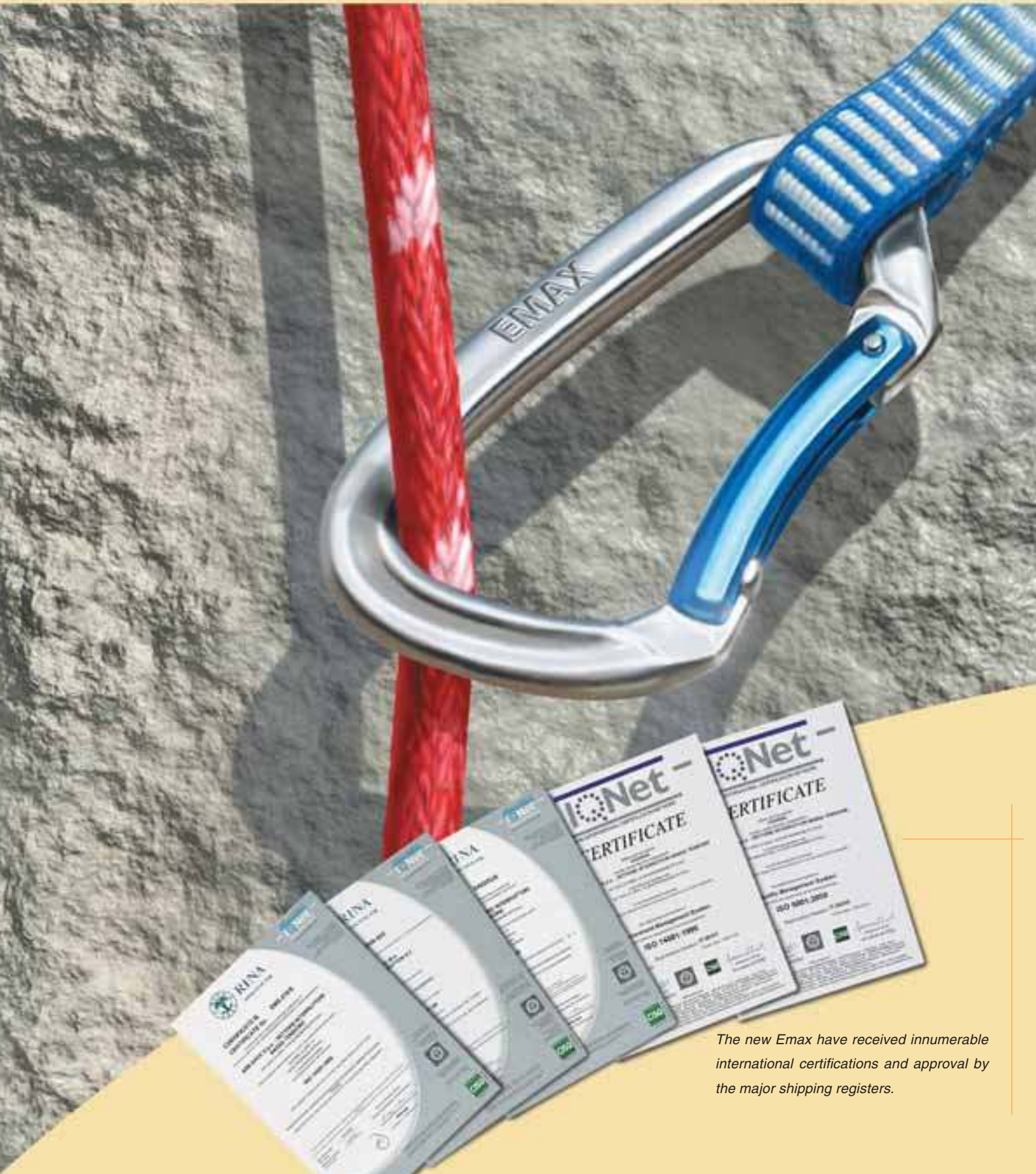

The new Emax have received innumerable international certifications and approval by the major shipping registers.



Careful selection of materials, meticulous assembly and a rigorous testing stage make the new Emax an extremely reliable and sturdy product, able to withstand high dynamic and thermal stresses for longer than any other circuit-breaker in its category. With the new standardised system of accessories studied and made for the new Emax, work becomes easier, convenient, safe and rapid. Furthermore, ABB SACE puts a highly specialised and rapid customer assistance service at your disposal. The new Emax give you that pleasant feeling of security which only such a reliable product is able to do.



Emax





Contents

Overview of the SACE Emax family

Fields of application 1/2

Construction characteristics

Structure of the circuit-breakers 1/4
Operating mechanism 1/5
Operating and signalling parts 1/6
Fixed parts of withdrawable circuit-breakers 1/7
Utilization category 1/8

Versions and connections 1/9

Electronic trip units

General characteristics 1/10
Versions available 1/12
Rating plugs 1/13

Compliance with Standards

Standards, approvals and certifications 1/14
A design dedicated to Quality and respect for the environment 1/15

Overview of the SACE Emax family

Fields of application

1



		E1		E2			
		E1B	E1N	E2B	E2N	E2S	E2L
Automatic circuit-breakers							
Poles	[No.]	3 - 4		3 - 4			
4p cb neutral current-carrying capacity	[%]	100					
Size (40 °C)	[A]	800-1000- 1250-1600	800-1000- 1250-1600	1600-2000	1000-1250- 1600-2000	800-1000- 1250-1600- 2000	1250-1600
Ue	[V~]	690	690	690	690	690	690
Icu (220...415V)	[kA]	42	50	42	66	85	130
Ics (220...415V)	[kA]	42	50	42	65	85	130
Icw (1s)	[kA]	42	50	42	55	65	10
Icw (3s)	[kA]	36	36	42	42	50	-

Automatic circuit-breakers with full-size neutral conductor

		Standard version		Standard version	
Poles	[No.]				
4p cb neutral current-carrying capacity	[%]				
Size (40 °C)	[A]				
Ue	[V~]				
Icu (220...415V)	[kA]				
Ics (220...415V)	[kA]				
Icw (1s)	[kA]				
Icw (3s)	[kA]				



		E1B/MS	E1N/MS	E2B/MS	E2N/MS	E2S/MS
Switch-disconnectors						
Poles	[No.]	3 - 4	3 - 4	3 - 4	3 - 4	3 - 4
Size (40 °C)	[A]	800-1000- 1250-1600	800-1000- 1250-1600	1600-2000	1000-1250- 1600-2000	1000-1250- 1600-2000
Ue	[V~]	690	690	690	690	690
Icw (1s)	[kA]	42	50	42	55	65
Icw (3s)	[kA]	36	36	42	42	42
Icm (220...440V)	[kA]	88.2	105	88.2	121	143

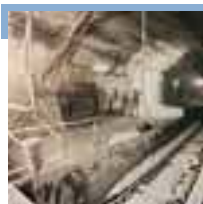

		E2B/E	E2N/E
Automatic circuit-breakers for applications up to 1150 V AC			
Poles	[No.]	3 - 4	3 - 4
Size (40 °C)	[A]	1600-2000	1250-1600- 2000
Ue	[V~]	1150	1150
Icu (1150V)	[kA]	20	30
Ics (1150V)	[kA]	20	30
Icw (1s)	[kA]	20	30

Switch-disconnectors for applications up to 1150 V AC

		E2B/E MS	E2N/E MS
Switch-disconnectors for applications up to 1150 V AC			
Poles	[No.]	3 - 4	3 - 4
Size (40 °C)	[A]	1600-2000	1250-1600- 2000
Ue	[V~]	1150	1150
Icw (1s)	[kA]	20	30
Icm (1000V)	[kA]	40	63

Switch-disconnectors for applications up to 1000 V DC E1B/E MS

		E2N/E MS
Switch-disconnectors for applications up to 1000 V DC E1B/E MS		
Poles	[No.]	3 - 4
Size (40 °C)	[A]	800-1250
Ue	[V~]	750 (3p)-1000(4p)
Icw (1s)	[kA]	20
Icm (750V)	[kA]	52.5
Icm (1000V)	[kA]	52.5

Sectionalizing truck

		E1 CS	E2 CS
Size (40 °C) [A]		1250	2000

Earthing switch with making capacity

		E1 MTP	E2 MTP
Size (40 °C) [A]		1250	2000

Earthing truck

		E1 MT	E2 MT
Size (40 °C) [A]		1250	2000

(*) The performance at 1000V is 50kA.

1

E3					E4			E6	
E3N	E3S	E3H	E3V	E3L	E4S	E4H	E4V	E6H	E6V
		3 - 4				3 - 4		3 - 4	
		100				50		50	
2500-3200	1000-1250-1600-2000-2500-3200	800-1000-1250-1600-2000-2500-3200	800-1250-1600-2000-2500-3200	2000-2500	4000	3200-4000	3200-4000	4000-5000-6300	3200-4000-5000-6300
690	690	690	690	690	690	690	690	690	690
66	75	100	130	130	75	100	150	100	150
66	75	85	100	130	75	100	150	100	125
66	75	75	85	15	75	100	100	100	100
66	65	65	65	-	75	75	75	85	85
					E4S/f	E4H/f	E6H/f		
Standard version					4	4	4		
					100	100	100		
					4000	3200-4000	4000-5000-6300		
					690	690	690		
					80	100	100		
					80	100	100		
					80	85	100		
					75	75	100		
E3N/MS	E3S/MS	E3V/MS		E4S/MS	E4S/f MS	E4H/MS	E4H/f MS	E6H/MS	E6H/f MS
3 - 4	3 - 4	3-4		3 - 4	4	3 - 4	4	3-4	4
2500-3200	1000-1250-1600-2000-2500-3200	800-1250-1600-2000-2500-3200		4000	4000	3200-4000	3200-4000	4000-5000-6300	4000-5000-6300
690	690	690		690	690	690	690	690	690
65	75	85		75	75	100	85	100	100
65	65	65		75	75	75	75	85	85
143	165	187		165	165	220	187	220	220
E3H/E					E4H/E		E6H/E		
3 - 4					3 - 4		3 - 4		
1250-1600-2000-2500-3200					3200-4000		4000-5000-6300		
1150					1150		1150		
30 (*)					65		65		
30 (*)					65		65		
30 (*)					65		65		
E3H/E MS					E4H/E MS		E6H/E MS		
3 - 4					3 - 4		3 - 4		
1250-1600-2000-2500-3200					3200-4000		4000-5000-6300		
1150					1150		1150		
50					65		65		
105					143		143		
E3H/E MS					E4H/E MS		E6H/E MS		
3 - 4					3 - 4		3 - 4		
1250-1600-2000-2500-3200					3200-4000		4000-5000-6300		
750 (3p)-1000(4p)					750 (3p) - 1000 (4p)		750 (3p) - 1000 (4p)		
40					65		65		
105					143		143		
105					143		143		
E3 CS					E4 CS		E6 CS		
3200					4000		6300		
E3 MTP					E4 MTP		E6 MTP		
3200					4000		6300		
E3 MT					E4 MT		E6 MT		
3200					4000		6300		



Construction characteristics

Structure of the circuit-breakers

The sheet steel structure of the Emax air circuit-breaker is extremely compact, considerably reducing overall dimensions. Safety is improved by using double insulation of the live parts and total segregation between phases.

The sizes have the same height and depth for all the circuit-breakers in each version.

The depth of the withdrawable version is suitable for installation in switchgear 500 mm deep.

The width of 324 mm (up to 2000 A) in the withdrawable version allows the apparatus to be used in switchgear compartments 400 mm wide. Their compact dimensions also mean they can replace air circuit-breakers of any size from earlier series.

1



1SDC200018F0001

1SDC200018F0001

Construction characteristics

Operating mechanism

The operating mechanism is of the stored energy type, operated using pre-charged springs.

The springs are charged manually by operating the front lever or using a geared motor, supplied on request.

The opening springs are charged automatically during the closing operation.

With the operating mechanism fitted with shunt closing and opening releases and the geared motor for charging the springs, the circuit-breaker can be operated by remote control and, if required, co-ordinated by a supervision and control system.

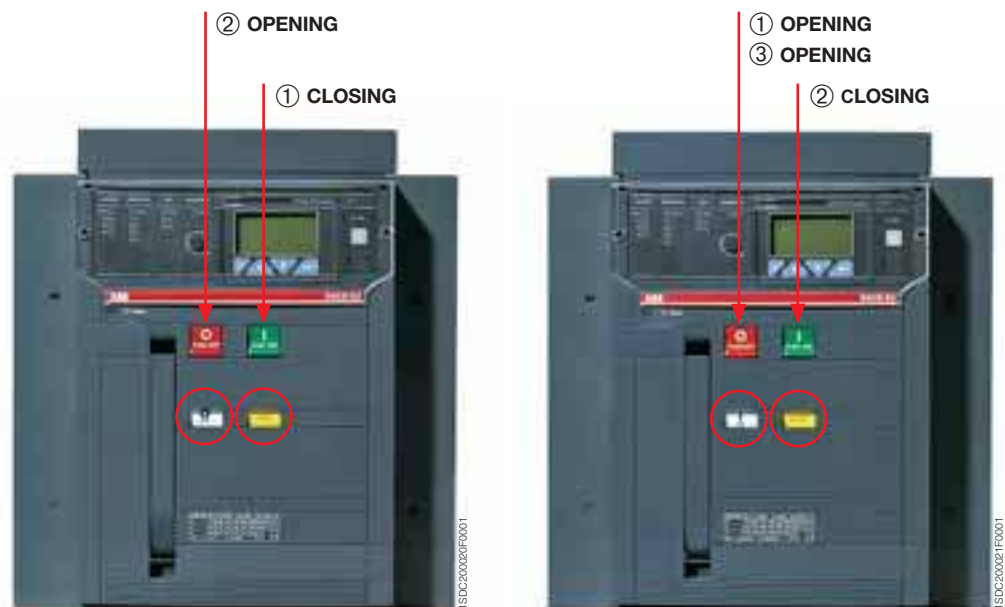

The following operating cycles are possible without recharging the springs:

- starting with the circuit-breaker open (0) and the springs charged:
closing-opening
- starting with the circuit-breaker closed (I) and the springs charged:
opening-closing-opening.

The same operating mechanism is used for the entire series and is fitted with a mechanical and electrical anti-pumping device.



Construction characteristics

Operating and signalling parts

1

Fixed version



Caption

- 1 Trademark and size of circuit breaker
- 2 SACE PR121, PR122 or PR123 trip unit
- 3 Pushbutton for manual opening
- 4 Pushbutton for manual closing
- 5 Lever to manually charge closing springs
- 6 Electrical rating plate
- 7 Mechanical device to signal circuit-breaker open "O" and close "C"
- 8 Signal for springs charged or discharged
- 9 Mechanical signalling of overcurrent release tripped
- 10 Key lock in open position
- 11 Key lock and padlock in racked-in/racked-out position (for withdrawable version only)
- 12 Racking-in/out device (for withdrawable version only)
- 13 Terminal box (for fixed version only)
- 14 Sliding contacts (for withdrawable version only)
- 15 Circuit-breaker position indicator: racked-in / test isolated / racked-out / connected / test isolated / disconnected (for withdrawable version only)

Withdrawable version

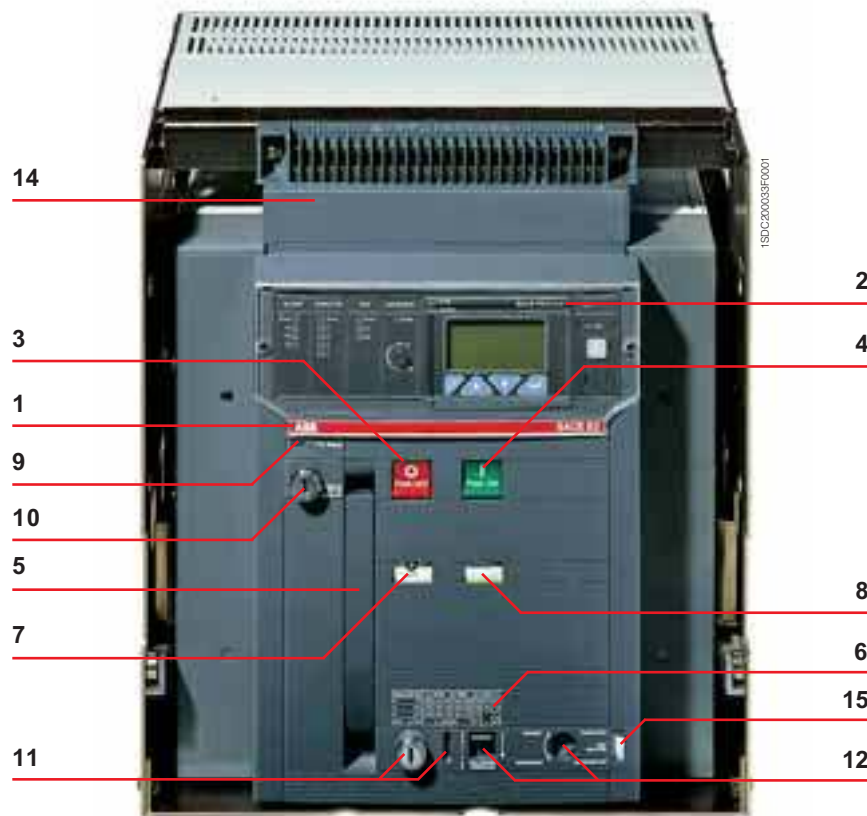

Note:

"Racked-in" refers to the position in which both the power contacts and auxiliary contacts are connected; "racked-out" is the position in which both the power contacts and auxiliary contacts are disconnected; "test isolated" is the position in which the power contacts are disconnected, whereas the auxiliary contacts are connected.

Construction characteristics

Fixed parts of withdrawable circuit-breakers

The fixed parts of withdrawable circuit-breakers have shutters for segregating the fixed contacts when the circuit-breaker is withdrawn from the compartment. These can be locked in their closed position using padlock devices.

Caption

- 1 Sheet steel supporting structure
- 2 Single earthing clamp mounted on the left for E1, E2 and E3, double earthing clamps for E4 and E6
- 3 Safety shutters (protection class IP20)
- 4 Terminal support base
- 5 Safety shutters (protection class IP20)
- 6 Contacts signalling that the circuit-breaker is racked-in, test isolated, racked-out
- 7 Safety shutters (protection class IP20)
- 8 Padlock device for safety shutters (on request)
- 9 Safety shutters (protection class IP20)

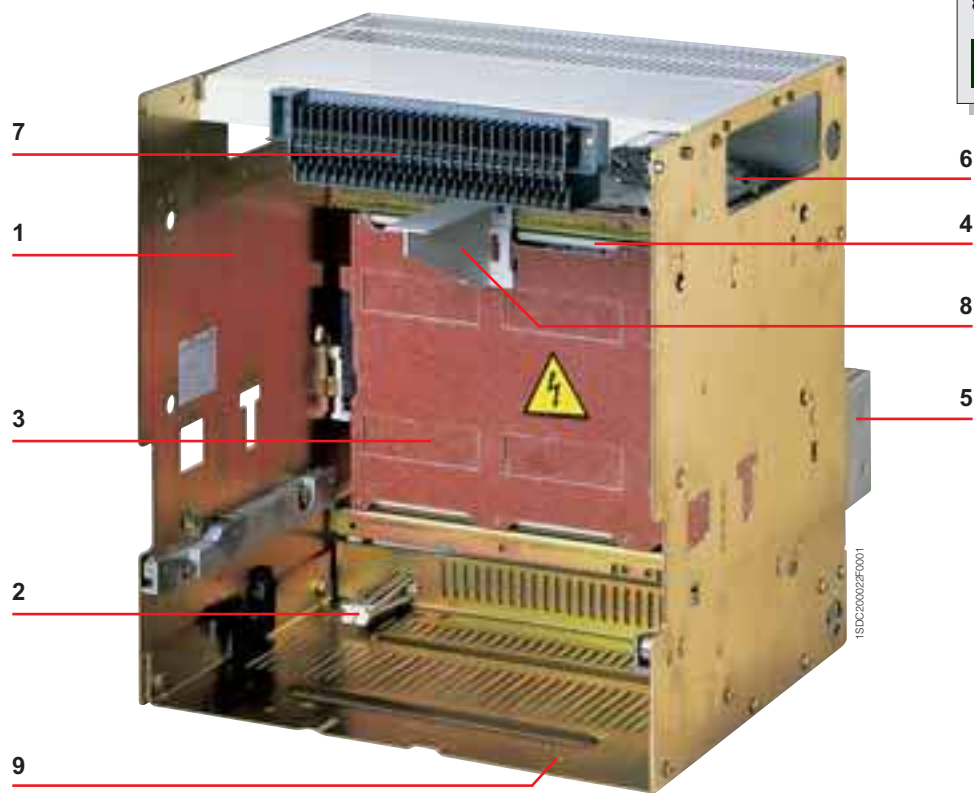

1



Construction characteristics

Utilization category

1

Selective and current-limiting circuit-breakers

Selective (non current-limiting) **circuit-breakers** are classified in class B (according to the IEC 60947-2 Standard). It is important to know their I_{cw} values in relation to any possible delayed trips in the event of short-circuits.

The **current-limiting circuit-breakers** E2L and E3L belong to class A. The short-time withstand current I_{cw} is not very important for these circuit-breakers, and is necessarily low due to the operating principle on which they are based. The fact that they belong to class A does not preclude the possibility of obtaining the necessary selectivity (e.g. current-type or time-type selectivity).

The special advantages of current-limiting circuit-breakers should also be underlined. In fact, they make it possible to:

- significantly reduce the peak current in relation to the prospective value;
- drastically limit specific let-through energy.

The resulting benefits include:

- reduced electrodynamic stresses;
- reduced thermal stresses;
- savings on the sizing of cables and busbars;
- the possibility of coordinating with other circuit-breakers in the series for back-up or discrimination.

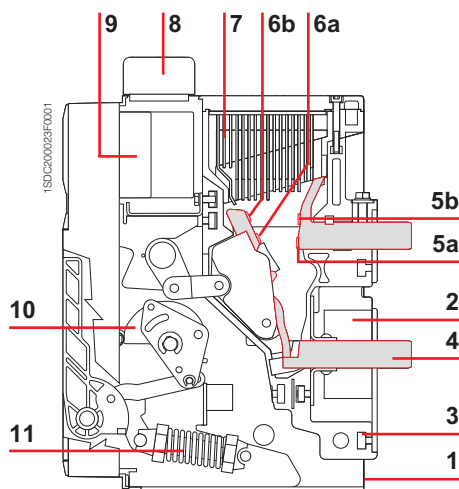

Selective circuit-breaker

E1 B-N, E2 B-N-S, E3 N-S-H-V,
E4 S-H-V, E6 H-V

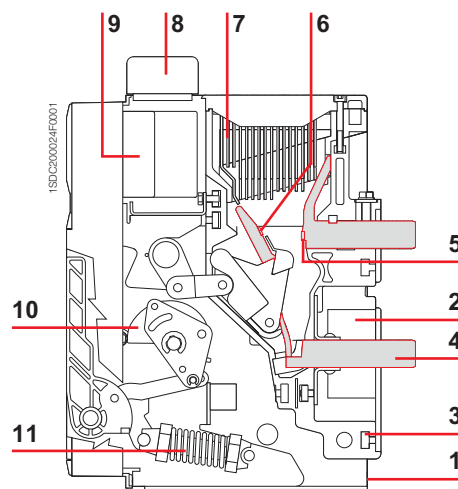

Current-limiting circuit-breaker

E2 L, E3 L

Caption	
1	Sheet steel supporting structure
2	Current transformer for protection trip unit
3	Control springs
4	Horizontal rear terminals
5	Plates for fixed arcing contacts
5a	Plates for fixed arcing contacts
5b	Plates for fixed arcing contacts
6	Plates for moving arcing contacts
6a	Plates for moving arcing contacts
6b	Plates for moving arcing contacts
7	Terminal box for fixed version - Sliding contacts for withdrawable version
8	Terminal box for fixed version - Sliding contacts for withdrawable version
9	Terminal box for fixed version - Sliding contacts for withdrawable version
10	Circuit-breaker closing and opening control
11	Closing springs

Versions and connections

All the circuit-breakers are available in fixed and withdrawable, three-pole or four-pole versions.

Each series of circuit-breakers offers terminals made of silver-plated copper bars, with the same dimensions, regardless of the rated currents of the circuit-breakers.

The fixed parts for withdrawable circuit-breakers are common to each model, regardless of the rated current and breaking capacity of the relative moving parts, except for the E2S circuit-breaker which requires a specific fixed part.

A version with gold-plated terminals is available for special requirements, linked to use of the circuit-breakers in corrosive environments.

The availability of various types of terminals makes it possible to build wall-mounted switchgear, or switchgear to be accessed from behind with rear connections.

For special installation needs, the circuit-breakers can be fitted with various combinations of top and bottom terminals.

Furthermore new dedicated terminal conversion kits give Emax maximum flexibility, allowing horizontal terminals to be changed to vertical or front ones and vice versa.

Fixed circuit-breaker

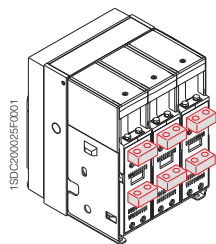

Horizontal rear terminals

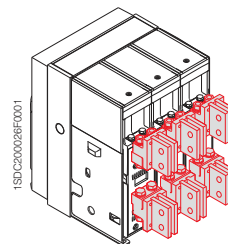

Vertical rear terminals

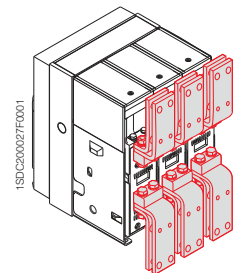

Front terminals

Withdrawable circuit-breaker

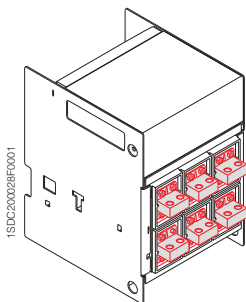

Horizontal rear terminals

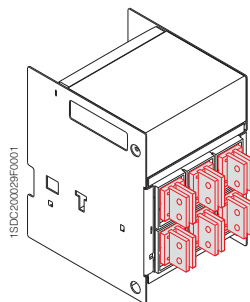

Vertical rear terminals

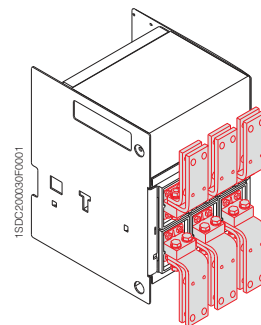

Front terminals

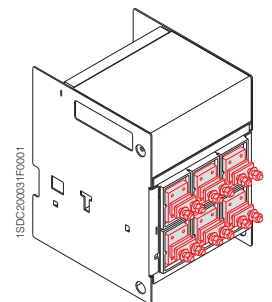

Flat terminals



Electronic trip units

General characteristics

The overcurrent protection for AC installations uses three types of electronic trip unit series: PR121, PR122 and PR123.

The basic series, PR121, offers the whole set of standard protection functions, complete with a user-friendly interface.

It allows discrimination of which fault caused the trip by means of the new led indications.

PR122 and PR123 trip units are of new concept modular architecture. It is now possible to have a complete series of protections, accurate measurements, signalling or dialogue functions, designed and customisable for all application requirements.

The protection system is made up of:

- 3 or 4 new generation current sensors (Rogowsky coil);
- external current sensors (i.e. for external neutral, residual current or source ground return protection);
- a protection unit selected among PR121/P, PR122/P or PR123/P with optional communication module via Modbus or Fieldbus plug network (PR122/P and PR123/P only), as well as via a wireless connection;
- an opening solenoid, which acts directly on the circuit-breaker operating mechanism (supplied with the protection unit).



General specifications of the electronic trip units include:

- operation without the need for an external power supply
- microprocessor technology
- high precision
- sensitivity to the true R.M.S. value of the current
- trip cause indication and trip data recording
- interchangeability among all types of trip units
- setting for neutral configurable:
 - OFF-50%-100%-200% of phase setting for circuit-breakers E1, E2, E3 and E4/f, E6/f full-size versions, and E4-E6 with external neutral protection;
 - OFF-50% for standard E4 and E6.

The main performance features of the trip units are listed below.

PR121

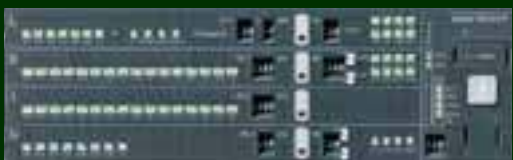

Protection PR121/P PR121/P PR121/P

L I L S I L S I G

PR122

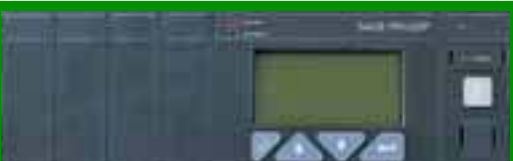

Protection PR122/P PR122/P PR122/P PR122/P

L I L S I L S I G L S I Rc

For all versions U OT M

New modules available:

Measuring	opt.	UV OV RV RP UF OF
Communication	opt.	
Signalling	opt.	
Bluetooth (wireless link)	opt.	

PR123



Protection PR123/P PR123/P

L S I L S I G

For all versions OT D U UV OV RV RP M UF OF

New modules available:

Communication	opt.	
Signalling	opt.	
Bluetooth (wireless link)	opt.	

Electronic trip units

Versions available

Features

Protection functions	PR121	PR122	PR123
L Protection against overload with inverse long time-delay trip	■	■	■
S Selective protection against short-circuit inverse or definite short time-delay trip	■	■	■
S Second selective protection against short-circuit inverse or definite short time-delay trip			■
I Protection against instantaneous short-circuit with adjustable trip current threshold	■	■	■
G Protection against earth fault (residual source ground return)	■	■	■
Rc Residual current ⁽¹⁾		opt. ⁽²⁾	■
D Protection against directional short-circuit with adjustable time-delay			■
U Protection against phase unbalance		■	■
OT Protection against overtemperature (check)		■	■
UV Protection against undervoltage		opt. ⁽³⁾	■
OV Protection against overvoltage		opt. ⁽³⁾	■
RV Protection against residual voltage		opt. ⁽³⁾	■
RP Protection against reverse active power		opt. ⁽³⁾	■
M Thermal memory for functions L and S		■	■
UF Underfrequency		opt. ⁽³⁾	■
OF Overfrequency		opt. ⁽³⁾	■

Measurements

Currents (phase, neutral, earth fault)		■	■
Voltage (phase-phase, phase-neutral, residual)		opt. ⁽³⁾	■
Power (active, reactive, apparent)		opt. ⁽³⁾	■
Power factor		opt. ⁽³⁾	■
Frequency and peak factor		opt. ⁽³⁾	■
Energy (active, reactive, apparent, meter)		opt. ⁽³⁾	■
Harmonics calculation (display of wave forms and harmonics module)			■

Event marking and maintenance data

Event marking with the instant it occurred	opt. ⁽⁴⁾	■	■
Chronological event storage	opt. ⁽⁴⁾	■	■
Counting the number of operations and contact wear		■	■

Communication with supervision system and centralised control

Remote parameter setting of the protection functions, unit configuration, communication		opt. ⁽⁵⁾	opt. ⁽⁵⁾
Transmission of measurements, states and alarms from circuit-breaker to system		opt. ⁽⁵⁾	opt. ⁽⁵⁾
Transmission of the events and maintenance data from circuit-breaker to system		opt. ⁽⁵⁾	opt. ⁽⁵⁾

Watchdog

Warn and trip for release overtemperature		■	■
Check of release status	■	■	■

Interface with the user

Presetting parameters by means of dip switches	■		
Presetting parameters by means of keys and LCD viewer		■	■
Warn signals for functions L, S, I and G	■	■	■
Alarm signal of one of the following protections: undervoltage, overvoltage, residual voltage, active reverse of power, phase unbalance, overtemperature		opt. ⁽³⁾	■
Complete management of the alarms and alarms for all the self-control protection functions		■	■
Enabling password for use with consultation in "READ" mode or consultation and setting in "EDIT" mode		■	■

Load control

Load connection and disconnection according to the current passing through the circuit-breaker		■	■
--	--	---	---

Zone selectivity

Can be activated for protection functions S, G and (PR123 only) D		■	■
---	--	---	---

(1) requires a homopolar toroid for residual current protection; (2) the RC function is available with PR122LSIRc or with PR122LSIG and module PR120/V; (3) with PR120/V; (4) with BT030 communication unit; (5) with PR120/D-M

Electronic trip units

Rating plugs

A new concept for setting the current ratings

Rating plugs

Type of circuit-breaker	Max rated uninterrupted current	In [A]											
		400	630	800	1000	1250	1600	2000	2500	3200	4000	5000	6300
E1B	800	■	■	■	■	■	■	■	■	■	■	■	■
	1000-1250	■	■	■	■	■	■	■	■	■	■	■	■
	1600	■	■	■	■	■	■	■	■	■	■	■	■
E1N	800	■	■	■	■	■	■	■	■	■	■	■	■
	1000-1250	■	■	■	■	■	■	■	■	■	■	■	■
	1600	■	■	■	■	■	■	■	■	■	■	■	■
E2B	1600	■	■	■	■	■	■	■	■	■	■	■	■
	2000	■	■	■	■	■	■	■	■	■	■	■	■
E2N	1000-1250	■	■	■	■	■	■	■	■	■	■	■	■
	1600	■	■	■	■	■	■	■	■	■	■	■	■
	2000	■	■	■	■	■	■	■	■	■	■	■	■
E2S	800	■	■	■	■	■	■	■	■	■	■	■	■
	1000-1250	■	■	■	■	■	■	■	■	■	■	■	■
	1600	■	■	■	■	■	■	■	■	■	■	■	■
E2L	1250	■	■	■	■	■	■	■	■	■	■	■	■
	1600	■	■	■	■	■	■	■	■	■	■	■	■
	2000	■	■	■	■	■	■	■	■	■	■	■	■
E3N	2500	■	■	■	■	■	■	■	■	■	■	■	■
	3200	■	■	■	■	■	■	■	■	■	■	■	■
E3S	1000-1250	■	■	■	■	■	■	■	■	■	■	■	■
	1600	■	■	■	■	■	■	■	■	■	■	■	■
	2000	■	■	■	■	■	■	■	■	■	■	■	■
	2500	■	■	■	■	■	■	■	■	■	■	■	■
E3H	3200	■	■	■	■	■	■	■	■	■	■	■	■
	800	■	■	■	■	■	■	■	■	■	■	■	■
	1000-1250	■	■	■	■	■	■	■	■	■	■	■	■
	1600	■	■	■	■	■	■	■	■	■	■	■	■
	2000	■	■	■	■	■	■	■	■	■	■	■	■
E3V	2500	■	■	■	■	■	■	■	■	■	■	■	■
	3200	■	■	■	■	■	■	■	■	■	■	■	■
	800	■	■	■	■	■	■	■	■	■	■	■	■
	1250	■	■	■	■	■	■	■	■	■	■	■	■
	1600	■	■	■	■	■	■	■	■	■	■	■	■
E3L	2000	■	■	■	■	■	■	■	■	■	■	■	■
	2500	■	■	■	■	■	■	■	■	■	■	■	■
E4S, E4S/f	4000	■	■	■	■	■	■	■	■	■	■	■	■
E4H, E4H/f	3200	■	■	■	■	■	■	■	■	■	■	■	■
	4000	■	■	■	■	■	■	■	■	■	■	■	■
E4V	3200	■	■	■	■	■	■	■	■	■	■	■	■
	4000	■	■	■	■	■	■	■	■	■	■	■	■
E6H, E6H/f	4000	■	■	■	■	■	■	■	■	■	■	■	■
	5000	■	■	■	■	■	■	■	■	■	■	■	■
E6V	6300	■	■	■	■	■	■	■	■	■	■	■	■
	3200	■	■	■	■	■	■	■	■	■	■	■	■
	4000	■	■	■	■	■	■	■	■	■	■	■	■
	5000	■	■	■	■	■	■	■	■	■	■	■	■
	6300	■	■	■	■	■	■	■	■	■	■	■	■
	6300	■	■	■	■	■	■	■	■	■	■	■	■

1

Compliance with Standards

Standards, approvals and certifications

SACE Emax circuit-breakers and their accessories conform to the international IEC 60947, EN 60947 (harmonized in 30 CENELEC countries), CEI EN 60947 and IEC 61000 Standards, and comply with following EC directives:

- "Low Voltage Directive" (LVD) n° 73/23 EEC
- "Electromagnetic Compatibility Directive" (EMC) nr. 89/336 EEC.

The main versions of the apparatus are approved by the following Shipping Registers:

- RINA (Italian Naval Register)
- Det Norske Veritas
- Bureau Veritas
- Germanischer Lloyd
- Loyd's Register of Shipping
- Polskj Rejestr Statkow
- ABS (American Bureau of Shipping)
- RMRS (Russian Maritime Register of Shipping)
- NK (Nippon Kaiji Kyokai)

The Emax series also has a range which has undergone certification according to the severe American UL 1066 Standards. Furthermore, the Emax series is certified by the Russian GOST (Russia Certificate of Conformity) certification organization, and is certified by China CCC (China Compulsory Certification)

Certification of conformity with the aforementioned product Standards is carried out in compliance with European Standard EN 45011 by the Italian certification body ACAE (Associazione per la Certificazione delle Apparecchiature Elettriche - Association for Certification of Electrical Apparatus), recognized by the European organization LOVAG (Low Voltage Agreement Group), and by Swedish SEMKO certification organization recognized by the International organization IECCE.

Note: Contact ABB SACE for a list of approved types of circuit-breakers, approved performance data and the corresponding validity



Compliance with Standards

A design dedicated to Quality and respect for the environment

Quality, environment, health and safety have always been ABB SACE's major commitment. This commitment involves every function of the company, and has allowed us to achieve prestigious recognition internationally.

The company's quality management system is certified by RINA, one of the most prestigious international certification boards, and complies with ISO 9001-2000 Standards; the ABB SACE test facility is accredited by SINAL; the plant in Frosinone is also certified in compliance with ISO 14001 standard for the environment, OHSAS 18001 for health and safety in the workplace and SA800 for Social Responsibility.

ABB SACE, Italy's first industrial company in the electro-mechanical sector to achieve this, has been able to reduce its raw material consumption and machining scrap by 20% thanks to an ecology-centred revision of its manufacturing process. All of the company's Divisions are involved in streamlining raw material and energy consumption, preventing pollution, limiting noise pollution and reducing scrap resulting from manufacturing processes, as well as in carrying out periodic environmental audits of leading suppliers.

ABB SACE is committed to environmental protection, as is also evidenced by the Life Cycle Assessments (LCA) of products carried out at the Research Centre: this means that assessments and improvements of the environmental performance of products throughout their life cycle are included right from the initial engineering stage. The materials, processes and packaging used are chosen with a view to optimising the actual environmental impact of each product, including its energy efficiency and recyclability.



1SD2C00038F0001



1



Emax





Contents

SACE Emax automatic circuit-breakers	2/2
Automatic circuit-breakers with full-size neutral conductor	2/4
Switch-disconnectors	2/5
Automatic circuit-breakers for applications up to 1150V AC	2/6
Switch-disconnectors for applications up to 1150V AC	2/7
Switch-disconnectors for applications up to 1000V DC	2/8
Sectionalizing truck	2/9
Earthing switch with making capacity	2/10
Earthing truck	2/11
Other versions	2/11



SACE Emax automatic circuit-breakers

Common data

Voltages	
Rated service voltage Ue	[V] 690 -
Rated insulation voltage Ui	[V] 1000
Rated impulse withstand voltage Uimp	[kV] 12
Operating temperature	
Storage temperature	[°C] -40...+70
Frequency f	[Hz] 50 - 60
Number of poles	3 - 4
Versions	
	Fixed - Withdrawable



2

		E1		E2			
		B	N	B	N	S	L
Performance levels							
Currents: max rated uninterrupted current (at 40 °C)	[A]	800	800	1600	1000	800	1250
	[A]	1000	1600	2000	1250	1000	1600
	[A]	1250	1250	1600	1250		
	[A]	1600	1600	2000	1600		
	[A]			2000			
	[A]			2000			
Neutral pole current-carrying capacity for 4-pole CBs	[kA]	100	100	100	100	100	100
Rated ultimate breaking capacity under short-circuit <i>I_{cu}</i>							
220/230/380/400/415 V ~	[kA]	42	50	42	65	85	130
440 V ~	[kA]	42	50	42	66	85	110
500/525 V ~	[kA]	42	50	42	55	65	85
660/690 V ~	[kA]	42	50	42	55	65	85
Rated service breaking capacity under short-circuit <i>I_{cs}</i>							
220/230/380/400/415 V ~	[kA]	42	50	42	65	85	130
440 V ~	[kA]	42	50	42	65	85	110
500/525 V ~	[kA]	42	50	42	55	65	65
660/690 V ~	[kA]	42	50	42	55	65	65
Rated short-time withstand current <i>I_{cw}</i>	(1s) [kA]	42	50	42	55	65	10
	(3s) [kA]	35	35	35	35	35	35
Rated making capacity under short-circuit (peak value) <i>I_{cm}</i>							
220/230/380/400/415 V ~	[kA]	88.2	105	88.2	143	187	286
440 V ~	[kA]	88.2	105	88.2	143	187	242
500/525 V ~	[kA]	88.2	105	88.2	121	143	167
660/690 V ~	[kA]	88.2	105	88.2	121	143	187
Utilisation category (according to CEI EN 60947-2)							
		B	B	B	B	B	A
Isolation behaviour (according to CEI EN 60947-2)							
Overcurrent protection							
Electronic trip units for AC applications		■	■	■	■	■	■
Operating times							
Closing time (max)	[ms]	80	80	80	80	80	80
Opening time for <i>I_{cu}</i> (max)	[ms]	70	70	70	70	70	70
Breaking time for <i>I_{cw}</i> (max)	[ms]	30	30	30	30	30	12
Overall dimensions							
Fixed: H = 418 mm - D = 302 mm W (3/4 poles)	[mm]	296/386			296/386		
Withdrawable: H = 461 mm - D = 396.5 mm W (3/4 poles)	[mm]	324/414			324/414		
Weights (circuit-breaker complete with trip units and CS, excluding accessories)							
Fixed 3/4 poles	[kg]	45/54	45/54	50/61	50/61	50/61	52/63
Withdrawable 3/4 poles (including fixed part)	[kg]	70/82	70/82	78/93	78/93	78/93	80/95

(1) Without intentional delays; (2) The performance at 600V is 100kA.

		E1 B-N			E2 B-N-S			E2 L	
Max rated uninterrupted current (at 40 °C)	[A]	800	1000	1250	1600	800	1000	1250	1600
Mechanical life with regular ordinary maintenance	[No. operations x 1000]	25	25	25	25	25	25	20	20
Operation frequency	[Operations/hour]	60	60	60	60	60	60	60	60
Electrical life	(440 V ~) [No. operations x 1000]	10	10	10	15	15	12	10	4
	(690 V ~) [No. operations x 1000]	10	8	8	15	15	10	8	2
Operation frequency	[Operations/hour]	30	30	30	30	30	30	30	20



E3					E4			E6	
N	S	H	V	L	S	H	V	H	V
2500	1000	800	800	2000	4000	3200	3200	4000	3200
3200	1250	1000	1250	2500		4000	4000	5000	4000
	1600	1250	1600					6300	5000
	2000	1600	2000						6300
	2500	2000	2500						
	3200	2500	3200						
		3200							
100	100	100	100	100	50	50	50	50	50
66	75	100	130	130	75	100	150	100	150
66	75	100	130	110	75	100	150	100	150
66	75	100	100	85	75	100	130	100	130
66	75	85 ⁽²⁾	100	85	75	85 ⁽²⁾	100	100	100
66	75	85	100	130	75	100	150	100	125
66	75	85	100	110	75	100	150	100	125
66	75	85	85	65	75	100	130	100	100
66	75	85	85	65	75	85	100	100	100
66	75	75	85	15	75	100	100	100	100
66	65	65	65	-	75	75	75	85	85
143	165	220	286	286	165	220	330	220	330
143	165	220	286	242	165	220	330	220	330
143	165	220	220	187	165	220	286	220	286
143	165	187	220	187	165	187	220	220	220
B	B	B	B	A	B	B	B	B	B
■	■	■	■	■	■	■	■	■	■
■	■	■	■	■	■	■	■	■	■
80	80	80	80	80	80	80	80	80	80
70	70	70	70	70	70	70	70	70	70
30	30	30	30	12	30	30	30	30	30
		404/530				566/656			782/908
		432/558				594/684			810/936
66/80	66/80	66/80	66/80	72/83	97/117	97/117	97/117	140/160	140/160
104/125	104/125	104/125	104/125	110/127	147/165	147/165	147/165	210/240	210/240

E3 N-S-H-V						E3 L		E4 S-H-V		E6 H-V			
800	1000-1250	1600	2000	2500	3200	2000	2500	3200	4000	3200	4000	5000	6300
20	20	20	20	20	20	15	15	15	15	12	12	12	12
60	60	60	60	60	60	60	60	60	60	60	60	60	60
12	12	10	9	8	6	2	1.8	7	5	5	4	3	2
12	12	10	9	7	5	1.5	1.3	7	4	5	4	2	1.5
20	20	20	20	20	20	20	20	10	10	10	10	10	10

2



Automatic circuit-breakers with full-size neutral conductor

The Emax range of automatic circuit-breakers with full-size neutral conductor is used in special applications where the presence of third harmonics on individual phases can lead to a very high current on the neutral conductor.

Typical applications include installations with loads having high harmonics distortion (computers and electronic devices in general), lighting systems with a large number of fluorescent lamps, systems with inverters and rectifiers, UPS, and systems for adjusting the speed of electric motors.

This range includes standard circuit-breakers with full-size neutral conductor in sizes E1, E2, E3. Models E4 and E6 are available in the "Full size" version up to rated currents of 6300A.

Models E4/f and E6/f are available in fixed and withdrawable four-pole versions. These models can all be fitted with all accessories available for the Emax range, with the exception, on the E6/f model, of the mechanical interlocks made using flexible wires and 15 external auxiliary contacts, which are therefore incompatible.

All the models can be fitted with all the available versions of electronic protection relays, in the standard version.



13DC20068FR001

2

		E4S/f	E4H/f	E6H/f	
Max rated uninterrupted current (at 40 °C)	[A]	4000	3200	4000	
	[A]		4000	5000	
	[A]			6300	
Number of poles		4	4	4	
Rated service voltage U_n	[V ~]	690	690	690	
Rated ultimate breaking capacity under short-circuit I_{cu}					
220/230/380/400/415 V ~	[kA]	75	100	100	
	440 V ~	[kA]	80	100	100
	500/525 V ~	[kA]	75	100	100
660/690 V ~	[kA]	75	100	100	
Rated service breaking capacity under short-circuit I_{cs}					
220/230/380/400/415 V ~	[kA]	80	100	100	
	440 V ~	[kA]	80	100	100
	500/525 V ~	[kA]	75	100	100
660/690 V ~	[kA]	75	100	100	
Rated short-time withstand current I_{cw}					
(1s)	[kA]	75	95	100	
	(3s)	[kA]	75	75	85
Rated making capacity under short-circuit (peak value) I_{mk}					
220/230/380/400/415 V ~	[kA]	176	220	220	
	440 V ~	[kA]	176	220	220
	500/525 V ~	[kA]	165	220	220
660/690 V ~	[kA]	165	220	220	
Utilisation category (according to CEI EN 60947-2)		B	B	B	
Behavior on isolation (according to CEI EN 60947-2)		■	■	■	
Overall dimensions					
Fixed: H = 418 mm - D = 302 mm W	[mm]	746	746	1034	
Withdrawable: H = 461 - D = 396.5 mm W	[mm]	774	774	1062	
Weights (circuit-breaker complete with trip units and CS, excluding accessories)					
Fixed	[kg]	120	120	165	
Withdrawable	[kg]	170	170	250	

Switch-disconnectors

The switch-disconnectors are derived from the corresponding circuit-breakers, of which they maintain the overall dimensions and the possibility of mounting accessories.

This version only differs from the circuit-breakers in the absence of overcurrent trip units.

The circuit-breaker is available in both fixed and withdrawable, three-pole and four-pole versions. The switch-disconnectors, identified by the letters "/MS", can be used according to category of use AC-23A (switching motor loads or other highly inductive loads) in accordance with the IEC 60947-3 Standard. The electrical specifications of the switch-disconnectors are listed in the table below.

ISDCC00060F001



		E1B/MS	E1N/MS	E2B/MS	E2N/MS	E2S/MS	E3N/MS	E3S/MS	E3V/MS	E4S/MS	E4S/fMS	E4H/MS	E4H/fMS	E6H/MS	E6H/fMS
Max rated uninterrupted current (at 40 °C)	[A]	800	800	1600	1000	1000	2500	1000	800	4000	4000	3200	3200	4000	4000
	[A]	1000	1000	2000	1250	1250	3200	1250	1250			4000	4000	5000	5000
	[A]	1250	1250		1600	1600		1600	1600					6300	6300
	[A]	1600	1600		2000	2000		2000	2000						
	[A]							2500	2500						
	[A]							3200	3200						
Rated service voltage U_e	[V ~]	690	690	690	690	690	690	690	690	690	690	690	690	690	690
	[V -]	250	250	250	250	250	250	250	250	250	250	250	250	250	250
Rated insulation voltage U_i	[V ~]	1000	1000	1000	1000	1000	1000	1000	1000	1000	1000	1000	1000	1000	1000
Rated impulse withstand voltage U_{imp}	[kV]	12	12	12	12	12	12	12	12	12	12	12	12	12	12
Rated short-time withstand current I_{sw}	(1s) [kA]	42	50	42	55	65	65	75	85	75	75	100 ⁽¹⁾	85	100	100
	(3s) [kA]	36	36	42	42	50	65	65	65	75	75	75	75	85	85
Rated making capacity under short-circuit (peak value) I_{cm}	220/230/380/400/415/440 V ~ [kA]	88.2	105	88.2	121	143	143	165	187	165	165	220	187	220	220
	500/660/690 V ~ [kA]	88.2	105	88.2	121	143	143	165	187	165	165	220	187	220	220

Note: the breaking capacity I_{cu}, at the maximum rated use voltage, by means of external protection relay, with 500 ms maximum timing, is equal to the value of I_{sw} (1s), except:

(1) I_{cu} = 85kA @ 690V



Automatic circuit-breakers for applications up to 1150V AC

SACE Emax circuit-breakers can be supplied in a special version for rated service voltages up to 1150 V in AC.

Circuit-breakers in this version are identified by the letters of the standard range (rated service voltage up to 690 V AC) plus “/E”, and are derived from the corresponding standard SACE Emax circuit-breakers. They offer the same versions and accessories as the latter. The SACE Emax range of circuit-breakers for applications up to 1150V in AC can be either fixed and withdrawable, in both three-pole and four-pole versions. SACE Emax/E circuit-breakers are especially suitable for installation in mines, oil and chemical plants, and for traction. This range of Emax was tested at a voltage of 1250VAC.

The table below shows the electrical specifications of the range.



15DC200061F0001

2

		E2B/E		E2N/E		E3H/E			E4H/E**		E6H/E**					
Max rated uninterrupted current (at 40 °C)	[A]	1600	2000	1250	1600	2000	1250	1600	2000	2500	3200	3200	4000	4000	5000	6300
Rated service voltage U_e	[V~]	1150	1150	1150	1150	1150	1150	1150	1150	1150	1150	1150	1150	1150	1150	1150
Rated insulation voltage U_i	[V~]	1250	1250	1250	1250	1250	1250	1250	1250	1250	1250	1250	1250	1250	1250	1250
Rated ultimate breaking capacity under short-circuit I_{cu}																
1000 V	[kA]	20	20	30	30	30	50	50	50	50	50	65	65	65	65	65
1150 V	[kA]	20	20	30	30	30	30	30	30	30	30	65	65	65	65	65
Rated service breaking capacity under short-circuit I_{cs}																
1000 V	[kA]	20	20	30	30	30	50	50	50	50	50	65	65	65	65	65
1150 V	[kA]	20	20	30	30	30	30	30	30	30	30	65	65	65	65	65
Rated short-time withstand current I_{sw} (1s)	[kA]	20	20	30	30	30	50 (*)	50 (*)	50 (*)	50 (*)	50 (*)	65	65	65	65	65
Rated making capacity under short-circuit (peak value) I_{cm}																
1000 V	[kA]	40	40	63	63	63	105	105	105	105	105	143	143	143	143	143
1150 V	[kA]	40	40	63	63	63	63	63	63	63	63	143	143	143	143	143

(*) 30 kA @ 1150 V.

(**) E4H/E and E6H/E are not available in the full-size version.

Switch-disconnectors for applications up to 1150V AC

The switch-disconnectors complete the range of apparatus for applications at 1150V in alternating current (AC). These circuit-breakers conform with the IEC 60947-3 Standards.

Circuit-breakers in this version are identified by the letters of the standard range, where the rated service voltage is up to 690 V AC, plus “/E”, thus becoming SACE Emax/E MS. They are derived from the corresponding standard SACE Emax switch-disconnectors.

They are available in the three-pole and four-pole, fixed and withdrawable versions in the same sizes, with accessory options and installations as per the corresponding standard circuit-breakers. All the accessories available for the SACE Emax range can be used. Standard fixed parts may also be used for circuit-breakers in the withdrawable version. As per the corresponding automatic version, this range of Emax was tested at a voltage of 1250VAC.

1SDC20061F001



2

		E2B/E MS	E2N/E MS	E3H/E MS	E4H/E MS*	E6H/E MS*
Max rated current (at 40 °C)	[A]	1600	1250	1250	3200	4000
	[A]	2000	1600	1600	4000	5000
	[A]		2000	2000		6300
	[A]			2500		
	[A]			3200		
Poles		3/4	3/4	3/4	3/4	3/4
Rated service voltage U_e	[V]	1150	1150	1150	1150	1150
Rated insulation voltage U_i	[V]	1250	1250	1250	1250	1250
Rated impulse withstand voltage U_{imp}	[kV]	12	12	12	12	12
Rated short-time withstand current I_{cw} (1s)	[kA]	20	30	30 ⁽¹⁾	65	65
Rated making capacity I_{cm} 1150V AC (peak value)	[kA]	40	63	63 ⁽²⁾	143	143

Note: The breaking capacity I_{cu}, by means of external protection relay, with 500 ms maximum timing, is equal to the value of I_{cw} (1s).

(1) The performance at 1000V is 50 kA.

(2) The performance at 1000V is 105 kA.

* E4H/E and E6H/E are not available in the full-size version.



Switch-disconnectors for applications up to 1000V DC

ABB SACE has developed the SACE Emax/E MS range of switch-disconnectors for applications in direct current up to 1000V in compliance with the international IEC 60947-3 Standard. These non-automatic circuit-breakers are especially suitable for use as bus ties or main isolators in direct current systems, such as in applications involving electric traction.

The range covers all installation needs up to 1000V DC / 6300A.

They are available in fixed and withdrawable, three-pole and four-pole versions.

By connecting three breaking poles in series, it is possible to achieve a rated voltage of 750V DC, while with four poles in series the limit rises to 1000V DC.

The switch-disconnectors of the SACE Emax/E MS range maintain the overall dimensions and fixing points of the standard range circuit-breakers. They can be fitted with the various terminal kits and all the accessories common to the SACE Emax range. They cannot, of course, be associated with the electronic trip units, CSs and accessories for determining currents and for AC applications.

The withdrawable circuit-breakers should be used together with the special version fixed parts for applications at 750/1000V DC.



1SDC200061F0001

2

		E1B/E MS		E2N/E MS		E3H/E MS		E4H/E MS*		E6H/E MS*	
Max rated current (at 40 °C)	[A]	800		1250		1250		3200		4000	
	[A]	1250		1600		1600		4000		5000	
	[A]			2000		2000				6300	
	[A]					2500					
	[A]					3200					
Poles		3	4	3	4	3	4	3	4	3	4
Rated service voltage U_e	[V]	750	1000	750	1000	750	1000	750	1000	750	1000
Rated insulation voltage U_i	[V]	1000	1000	1000	1000	1000	1000	1000	1000	1000	1000
Rated impulse withstand voltage U_{imp}	[kV]	12	12	12	12	12	12	12	12	12	12
Rated short-time withstand current I_{cw} (1s)	[kA]	20	20 ⁽¹⁾	25	25 ⁽¹⁾	40	40 ⁽¹⁾	65	65	65	65
Rated making capacity I_{cm}	750V DC	[kA]	42	42	52.5	52.5	105	105	143	143	143
	1000V DC		–	42	–	52,5	–	105	–	143	–

Note: The breaking capacity I_{cu} , by means of external protection relay, with 500 ms maximum timing, is equal to the value of I_{cw} (1s).

(1) The performances at 750 V are:

- for E1B/E MS I_{cw} = 25 kA,
- for E2N/E MS I_{cw} = 40 kA and
- for E3H/E MS I_{cw} = 50 kA.

* For the dimensions of E4H/E MS and E6H/E MS in four-pole version, please refer to the corresponding automatic circuit-breakers with full-size neutral conductor.



Sectionalizing truck

Sectionalizing truck - CS

This version is derived from the corresponding withdrawable circuit-breaker, with replacement of all the breaking parts and the operating mechanism with simple connections between the top and bottom isolating contacts.

It is used as a no load isolator where this is required by the system.

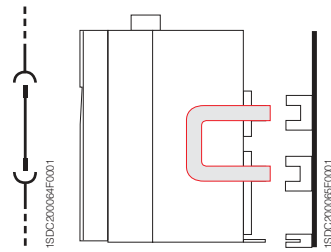



Earthing switch with making capacity

Earthing switch with making capacity - MTP

This version is based on the moving part of the corresponding withdrawable circuit-breaker (without overcurrent trip units) and the top or bottom isolating contacts, which are replaced with connections that short circuit the phases to earth through the circuit-breaker. The earthing switch is available with top or bottom isolating contacts.

The earthing circuit is dimensioned for a short-time withstand current equal to 60% of the maximum I_{cw} of the circuit-breaker from which it is derived (IEC 60439-1).

The earthing switch is inserted in the fixed part of a withdrawable circuit-breaker to earth the top or bottom terminals before carrying out inspection or maintenance operations in safe conditions on the external circuit. It should be used in cases where residual or recovery voltages can occur in the installations to be earthed.

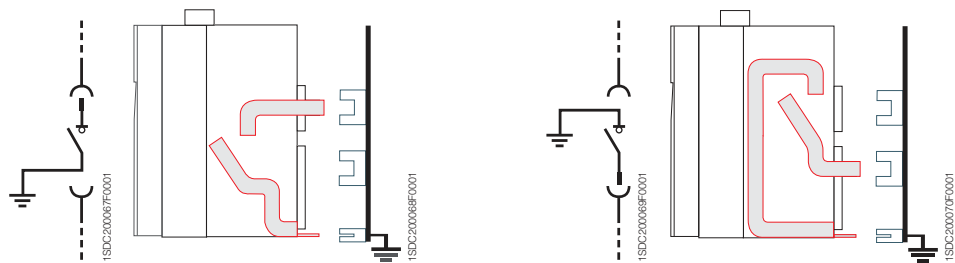



Earthing truck

Other versions

Earthing truck- MT

This version is similar to the sectionalizing truck, but with the bottom or top isolating contacts replaced by short-circuited, earthed connections. The earthing truck is available with bottom or top isolating contacts, suitable for the fixed part of the size.

The earthing circuit is dimensioned for a short-time withstand current equal to 60% of the maximum Icw of the circuit-breaker from which it is derived (IEC 60439-1).

The truck is temporarily racked into the fixed part of a withdrawable circuit-breaker to earth the top or bottom terminals before carrying out maintenance operations on the external circuit when no residual voltages are expected to occur.

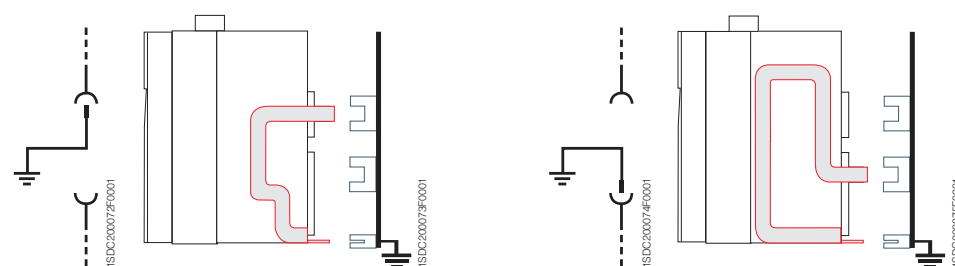

Other versions

On request, SACE Emax circuit-breakers can be built in special versions designed for particularly aggressive environments (SO₂/H₂S), for seismic installations or with the neutral pole on the right side.

Emax



SACE Emax 2P		4000	6300	10000	16000	20000	25000	32000	40000	50000	63000	80000	100000
U _n	V	230	415	480	525	600	690	720	800	1000	1100	1200	1500
I _n	A	25	100	125	160	200	250	315	400	500	630	800	1000
I _{cu}	kA	100	100	100	100	100	100	100	100	100	100	100	100
I _{cs}	kA	100	100	100	100	100	100	100	100	100	100	100	100
I _{cu}	kA	100	100	100	100	100	100	100	100	100	100	100	100
I _{cs}	kA	100	100	100	100	100	100	100	100	100	100	100	100

cos φ



Contents

Installation in switchgear

Modular design	3/2
Choosing the type of circuit-breaker	3/3
Current-carrying capacity in switchgear	3/6

Changing the rated uninterrupted current in relation to the temperature

Temperature derating	3/7
----------------------------	-----

Derating at different altitudes 3/12 |

Current-limiting and specific let-through energy curves

for E2L and E3L circuit-breakers	3/13
--	------



Installation in switchgear

Modular design

The circuit-breakers in the SACE Emax series have been built according to modular design criteria for easier installation and integration in low voltage electrical switchgear, thanks to their having the same depth and height for all the sizes, as well as a significant reduction in their overall installation dimensions.

The front shield of the circuit-breaker is also identical for the entire series. This simplifies construction of the switchgear doors since only one type of drilling is required and makes the front of the switchgear the same for all sizes.

SACE Emax circuit-breakers are suitable for Power Center switchgear and make it easy to comply with the segregation requirements of the IEC 60439-1 Standards.



1SDC20082F0001

Installation in switchgear

Choosing the type of circuit-breaker

Number of poles

The choice of the number of poles for circuit-breakers that simultaneously provide switching, protection and isolation functions in three-phase installations depends on the type of electrical system (TT, TN-S, TN-C, IT) and the type of user or, more generally, whether it features a distributed or non-distributed neutral.

Three-pole circuit breakers

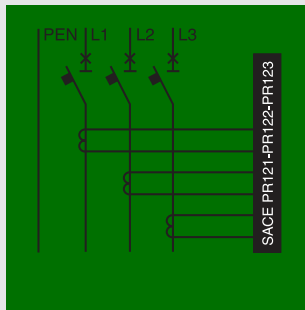

For TN-C systems (the neutral cannot be interrupted because it also acts as the protection conductor).

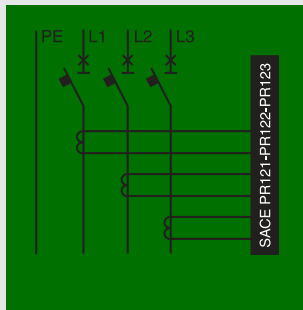

For users that do not use the neutral (e.g.: asynchronous motors) and, for systems with undistributed neutral in general.

Four-pole circuit breakers

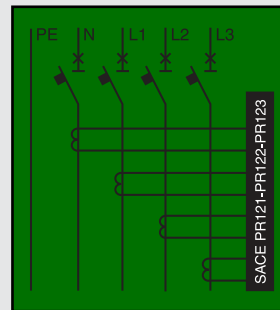

In all other instances, with exceptions for the IT system (see CEI 64-8/473.3.2.2 Standards).

Three-pole circuit breakers with external neutral

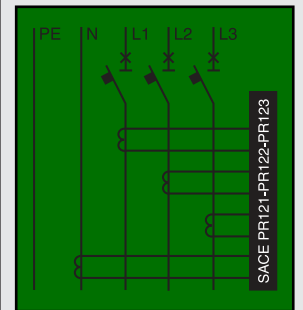

Current transformers can be installed on the external neutral of five-wire systems (TN-S) with 3-pole circuit-breakers.

3

Fixed or withdrawable version

The fixed version of the circuit-breaker is more compact in size than the withdrawable version. It is recommended for installations that can tolerate service interruptions in the event of faults or programmed maintenance.

The withdrawable version of the circuit-breaker is recommended for:

- applications that can only tolerate brief interruptions due to faults or programmed maintenance;
- dual lines, one of which is a standby for the other, with a single circuit-breaker for each pair.





Installation in switchgear

Choosing the type of circuit-breaker

Connecting the main circuit-breaker circuits

When designing switchgear, one must always bear in mind the problem of making the most rational connections between the circuit-breaker and main busbar system and from the busbars to the users. The SACE Emax series offers switchgear manufacturers a range of options to satisfy different circuit-breaker connection requirements.

The figures below give some indications for terminal selection.

3

Horizontal rear terminals

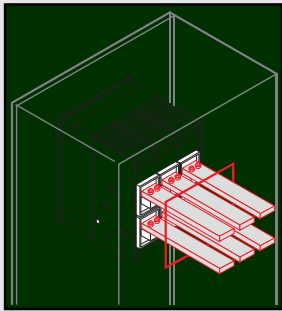

For switchgear with access from the rear

Vertical rear terminals

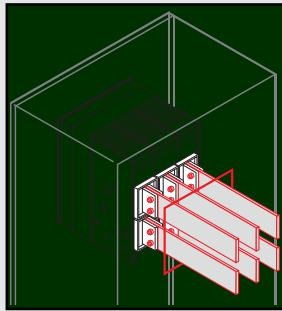

For switchgear with access from the rear

Front terminals

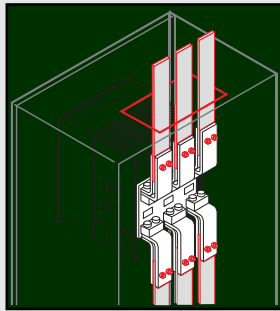

For wall-mounted switchgear, with access from the front only

Flat rear terminals

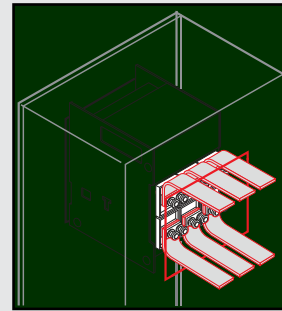

(withdrawable version only) For switchgear with access from the rear

Degrees of protection

A number of solutions have been adopted on SACE Emax circuit-breakers to achieve IP20 degree of protection for fixed or withdrawable circuit-breakers, excluding the terminals, and IP30 for their front parts using a flange. Automatic shutters have been designed for the fixed parts of withdrawable circuit-breakers which can be locked using padlock devices to allow maintenance on the load side or on the power-supply side of the fixed part.

A transparent protective cover is also available on request, to completely segregate the front of the circuit-breaker, reaching IP54 degree of protection. In any case, the front panel and protection trip unit with the relative indications remain completely visible.

IP20 Fixed or withdrawable version circuit-breaker, excluding the terminals.

IP30 Front parts of the circuit-breakers (using a flange).

IP54 Fixed or withdrawable version circuit-breaker, fitted with transparent protective cover to be fixed onto the front of the switchgear (on request).



1SDC200089F001

Power losses

The IEC 439-1 and CEI EN 60439-1 Standards prescribe calculations for determining the heat dissipation of ANS type switchgear (non-standard), for which the following must be taken into consideration:

- the overall dimensions
- the rated current of the bus-bars and connections and the relative dissipation
- the dissipated power of the apparatus mounted in the switchgear.

For this point, the table beside provides information on the circuit-breakers. For other apparatus, please consult the catalogues of the relative manufacturers.

Total power losses

Circuit breaker	Size [A]	Fixed Poles 3/4 Poles [W]	Withdrawable 3/4 Poles [W]
E1 B-N	800	65	95
	1000	96	147.2
	1250	150	230
E2 B-N-S	1600	253	376
	800	29	53
	1000	44.8	83.2
	1250	70	130
E2 L	1600	115	215
	2000	180	330
	1250	105	165
E3 N-S-H-V	1600	170	265
	800	22	36
E3 L	1000	38.4	57.6
	1250	60	90
	1600	85	150
	2000	130	225
	2500	205	350
E4 S-H-V	3200	330	570
	2000	215	330
E6 H-V	2500	335	515
	4000	360	660
E6 H-V	3200	170	290
	4000	265	445
	5000	415	700
	6300	650	1100

Note

The table values refer to balanced loads, a current flow of 1u, and automatic circuit-breakers.



Note

The same standards prescribe type tests for AS switchboards (standard factory-manufactured switchgear), including those for maximum temperature rise.



Installation in switchgear

Current-carrying capacity in switchgear

As an example, the following table shows the continuous current carrying capacity for circuit-breakers installed in a switchgear with the dimensions indicated below.

These values refer to withdrawable version circuit-breaker installed in non-segregated switchgear with a degree of protection up to IP31, and the following dimensions:

2300x800x900 (HxLxD) for E1 - E2 - E3;

2300x1400x1500 (HxLxD) for E4 - E6.

The values refer to a maximum temperature at the terminals of 120°C.

For withdrawable circuit-breakers with a rated current of 6300A, the use of vertical rear terminals is recommended.

Note:

The tables should be used solely as a general guideline for selecting products. Due to the extensive variety of switchgear construction shapes and conditions that can affect the behavior of the apparatus, the solution used must always be verified.

3

Type	Vertical terminals				Horizontal and front terminals			
	Continuous capacity [A]			Busbars section [mm ²]	Continuous capacity [A]			Busbars section [mm ²]
	35°C	45°C	55°C		35°C	45°C	55°C	
E1B/N 08	800	800	800	1x(60x10)	800	800	800	1x(60x10)
E1B/N 10	1000	1000	1000	1x(80x10)	1000	1000	1000	2x(60x8)
E1B/N 12	1250	1250	1250	1x(80x10)	1250	1250	1200	2x(60x8)
E1B/N 16	1600	1600	1500	2x(60x10)	1550	1450	1350	2x(60x10)
E2S 08	800	800	800	1x(60x10)	800	800	800	1x(60x10)
E2N/S 10	1000	1000	1000	1x(60x10)	1000	1000	1000	1x(60x10)
E2N/S 12	1250	1250	1250	1x(60x10)	1250	1250	1250	1x(60x10)
E2B/N/S 16	1600	1600	1600	2x(60x10)	1600	1600	1530	2x(60x10)
E2B/N/S 20	2000	2000	1800	3x(60x10)	2000	2000	1750	3x(60x10)
E2L 12	1250	1250	1250	1x(60x10)	1250	1250	1250	1x(60x10)
E2L 16	1600	1600	1500	2x(60x10)	1600	1500	1400	2x(60x10)
E3H/V 08	800	800	800	1x(60x10)	800	800	800	1x(60x10)
E3S/H 10	1000	1000	1000	1x(60x10)	1000	1000	1000	1x(60x10)
E3S/H/V 12	1250	1250	1250	1x(60x10)	1250	1250	1250	1x(60x10)
E3S/H/V 16	1600	1600	1600	1x(100x10)	1600	1600	1600	1x(100x10)
E3S/H/V 20	2000	2000	2000	2x(100x10)	2000	2000	2000	2x(100x10)
E3N/S/H/V 25	2500	2500	2500	2x(100x10)	2500	2450	2400	2x(100x10)
E3N/S/H/V 32	3200	3100	2800	3x(100x10)	3000	2850	2650	3x(100x10)
E3L 20	2000	2000	2000	2x(100x10)	2000	2000	1970	2x(100x10)
E3L 25	2500	2380	2250	2x(100x10)	2375	2270	2100	2x(100x10)
E4H/V 32	3200	3200	3200	3x(100x10)	3200	3150	3000	3x(100x10)
E4S/H/V 40	4000	3980	3500	4x(100x10)	3600	3510	3150	4x(60x10)
E6V 32	3200	3200	3200	3x(100x10)	3200	3200	3200	3x(100x10)
E6H/V 40	4000	4000	4000	4x(100x10)	4000	4000	4000	4x(100x10)
E6H/V 50	5000	4850	4600	6x(100x10)	4850	4510	4250	6x(100x10)
E6H/V 63	6000	5700	5250	7x(100x10)	-	-	-	-

Changing the rated uninterrupted current in relation to the temperature

Temperature derating

The circuit-breakers can operate at higher temperatures than their reference temperature (40 °C) under certain installation conditions. In these cases the current-carrying capacity of the switchgear should be reduced.

The SACE Emax series of air circuit-breakers uses electronic trip units which offer the benefit of great operating stability when subjected to temperature changes.

The tables below show the current-carrying capacities of the circuit breakers (as absolute values and percentage values) in relation to their rated values at T = 40 °C.

Withdrawable SACE Emax E1

Temperature (°C)	E1 800		E1 1000		E1 1250		E1 1600	
	%	[A]	%	[A]	%	[A]	%	[A]
10	100	800	100	1000	100	1250	100	1600
20	100	800	100	1000	100	1250	100	1600
30	100	800	100	1000	100	1250	100	1600
40	100	800	100	1000	100	1250	100	1600
45	100	800	100	1000	100	1250	98	1570
50	100	800	100	1000	100	1250	96	1536
55	100	800	100	1000	100	1250	94	1506
60	100	800	100	1000	100	1250	92	1472
65	100	800	100	1000	99	1240	89	1430
70	100	800	100	1000	95	1200	85	1360

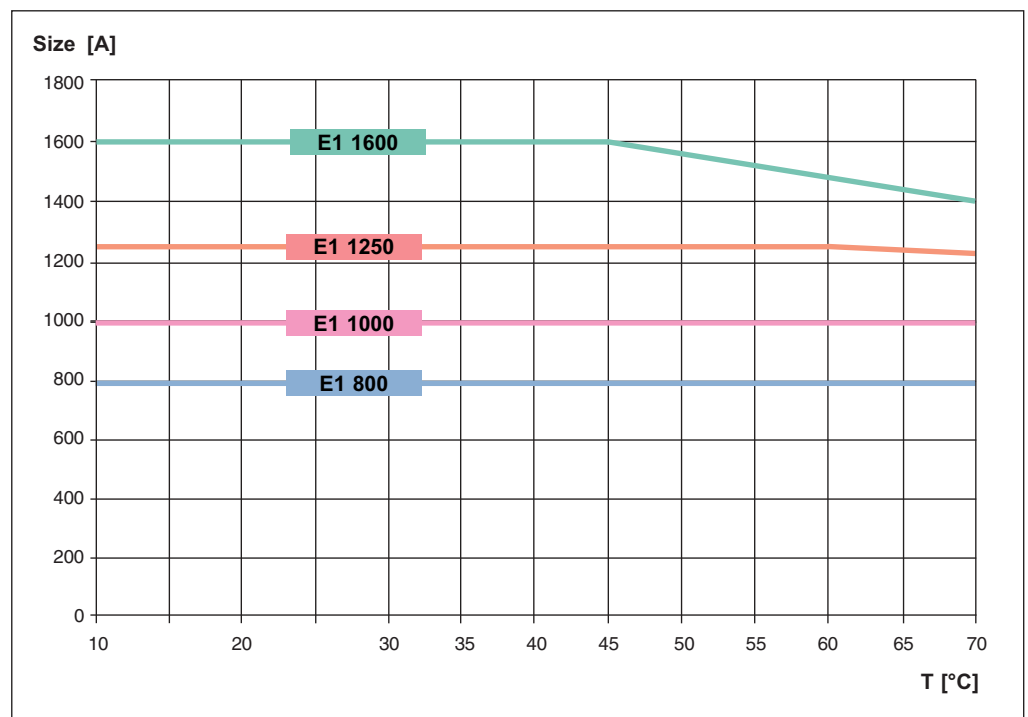

3



Changing the rated uninterrupted current in relation to the temperature

Temperature derating

Withdrawable SACE Emax E2

Temperature [°C]	E2 800		E2 1000		E2 1250		E2 1600		E2 2000	
	%	[A]	%	[A]	%	[A]	%	[A]	%	[A]
10	100	800	100	1000	100	1250	100	1600	100	2000
20	100	800	100	1000	100	1250	100	1600	100	2000
30	100	800	100	1000	100	1250	100	1600	100	2000
40	100	800	100	1000	100	1250	100	1600	100	2000
45	100	800	100	1000	100	1250	100	1600	100	2000
50	100	800	100	1000	100	1250	100	1600	97	1945
55	100	800	100	1000	100	1250	100	1600	94	1885
60	100	800	100	1000	100	1250	98	1570	91	1825
65	100	800	100	1000	100	1250	96	1538	88	1765
70	100	800	100	1000	100	1250	94	1510	85	1705

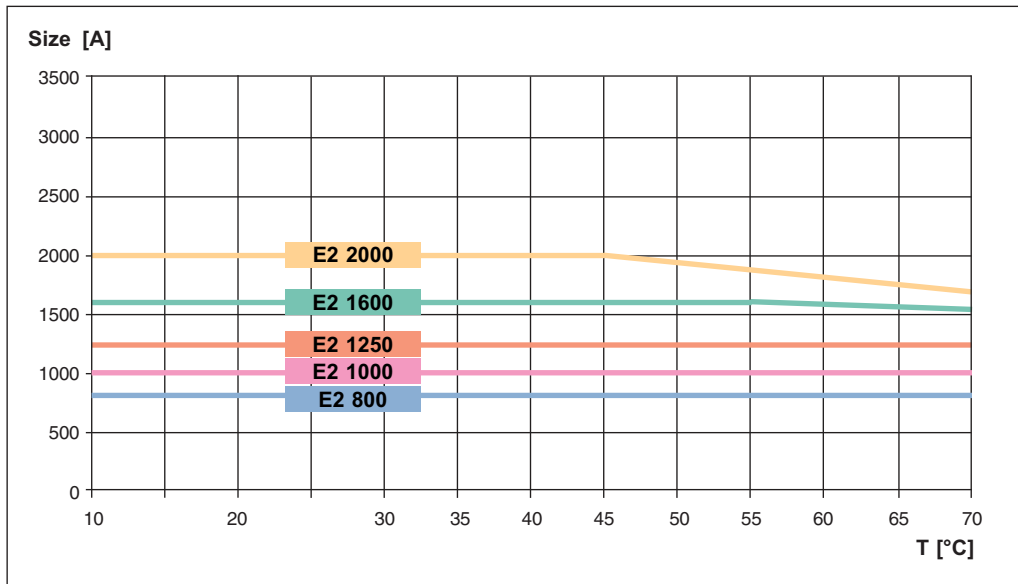

3

Withdrawable SACE Emax E3

Temperature T _{amb} [°C]	E3 800		E3 1000		E3 1250		E3 1600		E3 2000		E3 2500		E3 3200	
	%	[A]	%	[A]	%	[A]	%	[A]	%	[A]	%	[A]	%	[A]
10	100	800	100	1000	100	1250	100	1600	100	2000	100	2500	100	3200
20	100	800	100	1000	100	1250	100	1600	100	2000	100	2500	100	3200
30	100	800	100	1000	100	1250	100	1600	100	2000	100	2500	100	3200
40	100	800	100	1000	100	1250	100	1600	100	2000	100	2500	100	3200
45	100	800	100	1000	100	1250	100	1600	100	2000	100	2500	100	3200
50	100	800	100	1000	100	1250	100	1600	100	2000	100	2500	97	3040
55	100	800	100	1000	100	1250	100	1600	100	2000	100	2500	93	2975
60	100	800	100	1000	100	1250	100	1600	100	2000	100	2500	89	2880
65	100	800	100	1000	100	1250	100	1600	100	2000	97	2425	86	2745
70	100	800	100	1000	100	1250	100	1600	100	2000	81	2300	82	2700

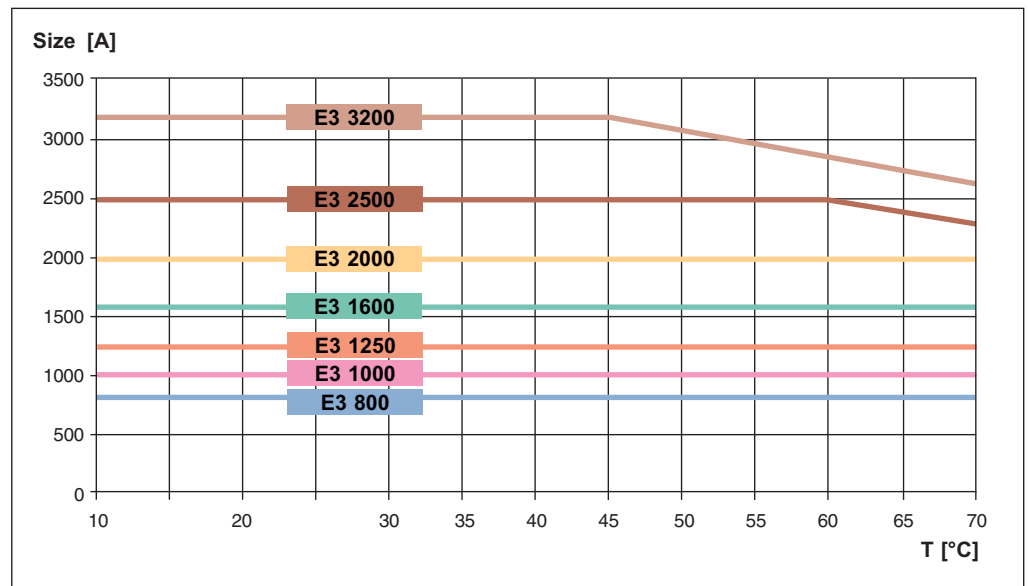

3



Changing the rated uninterrupted current in relation to the temperature

Temperature derating

Withdrawable SACE Emax E4

Temperature [°C]	E4 3200		E4 4000	
	%	[A]	%	[A]
10	100	3200	100	4000
20	100	3200	100	4000
30	100	3200	100	4000
40	100	3200	100	4000
45	100	3200	100	4000
50	100	3200	98	3900
55	100	3200	95	3790
60	100	3200	92	3680
65	98	3120	89	3570
70	95	3040	87	3480

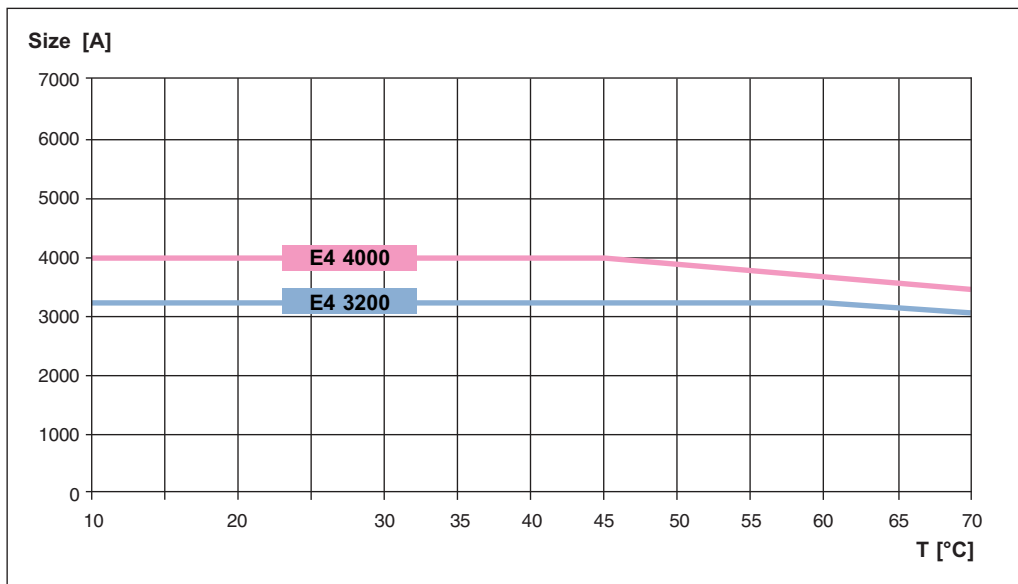

3

Withdrawable SACE Emax E6

Temperature [°C]	E6 3200		E6 4000		E6 5000		E6 6300	
	%	[A]	%	[A]	%	[A]	%	[A]
10	100	3200	100	4000	100	5000	100	6300
20	100	3200	100	4000	100	5000	100	6300
30	100	3200	100	4000	100	5000	100	6300
40	100	3200	100	4000	100	5000	100	6300
45	100	3200	100	4000	100	5000	100	6300
50	100	3200	100	4000	100	5000	100	6300
55	100	3200	100	4000	100	5000	98	6190
60	100	3200	100	4000	98	4815	96	5870
65	100	3200	100	4000	96	4815	94	5850
70	100	3200	100	4000	94	4725	92	5670

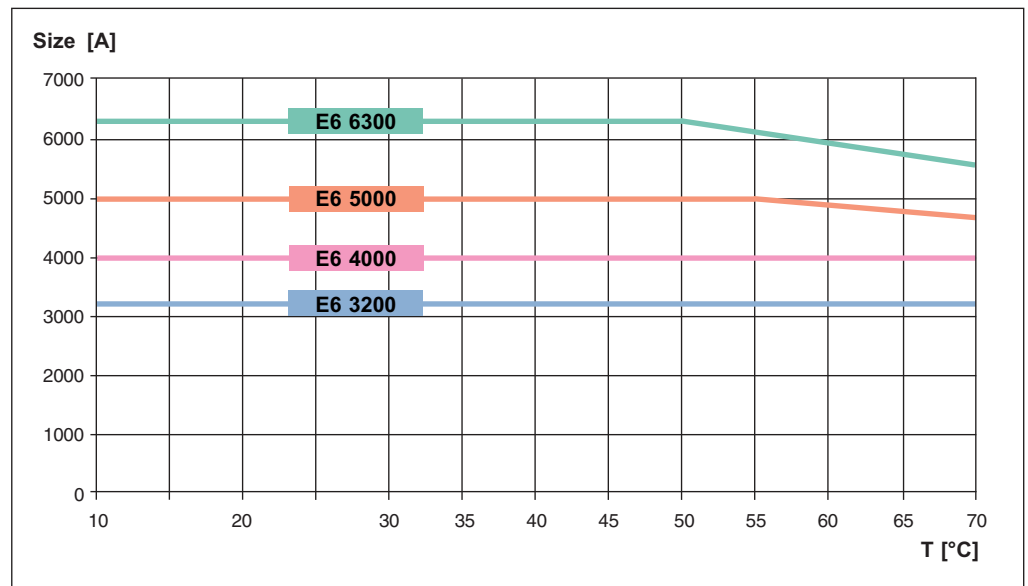

3



Derating at different altitudes

SACE Emax air circuit-breakers do not undergo any changes in their rated performance up to an altitude of 2000 meters.

As the altitude increases the atmospheric properties alter in terms of composition, dielectric capacity, cooling power and pressure.

The performance of the circuit-breakers therefore undergoes derating which can be measured through the variation in significant parameters such as the maximum operating voltage and the rated uninterrupted current.

The table below shows these values in relation to altitude.

Altitude	H [m]	<2000	3000	4000	5000
Rated service voltage	Ue [V]	690	600	500	440
Rated current	I_n [A]	I_n	0.95I _n	0.93I _n	0.90I _n

Current-limiting and specific let-through energy curves for E2L and E3L circuit-breakers

The current-limiting capacity of a current-limiting circuit-breaker indicates its greater or lesser capacity, under short-circuit conditions, to let through or make a current lower than the prospective fault current. This characteristic is shown by two different curves which indicate the following, respectively:

- the value of the specific energy “ I^2t ” (in A^2s) let through by the circuit-breaker in relation to the uninterrupted symmetrical short-circuit current.
- the peak value (in kA) of the limited current in relation to the uninterrupted symmetrical short-circuit current.

The graph shown at the side schematically indicates the trend of the uninterrupted current, with the relative established peak (curve B), and the trend of the limited current with the lowest peak value (curve A).

Comparing the areas beneath the two curves shows how the specific let-through energy is reduced as a result of the limiting effects of the circuit breaker.

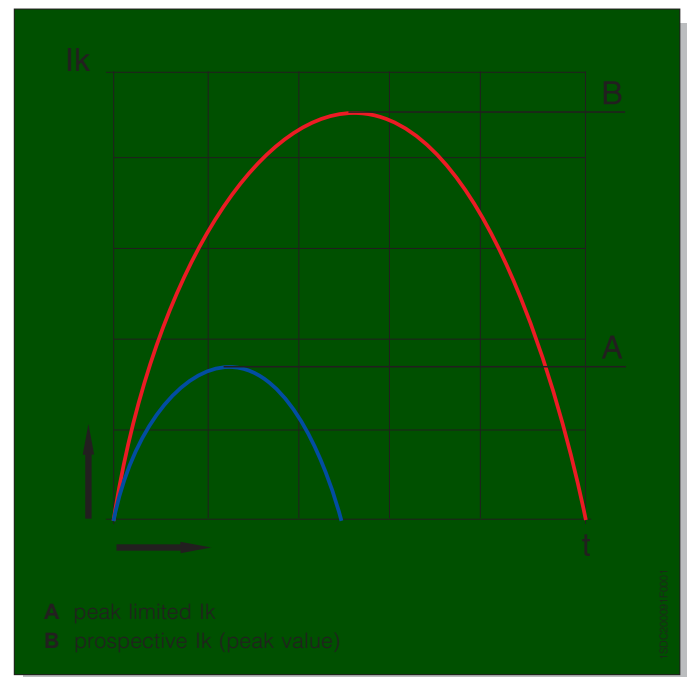



Current-limiting and specific let-through energy curves for E2L and E3L circuit-breakers

E2L

Current-limiting curves

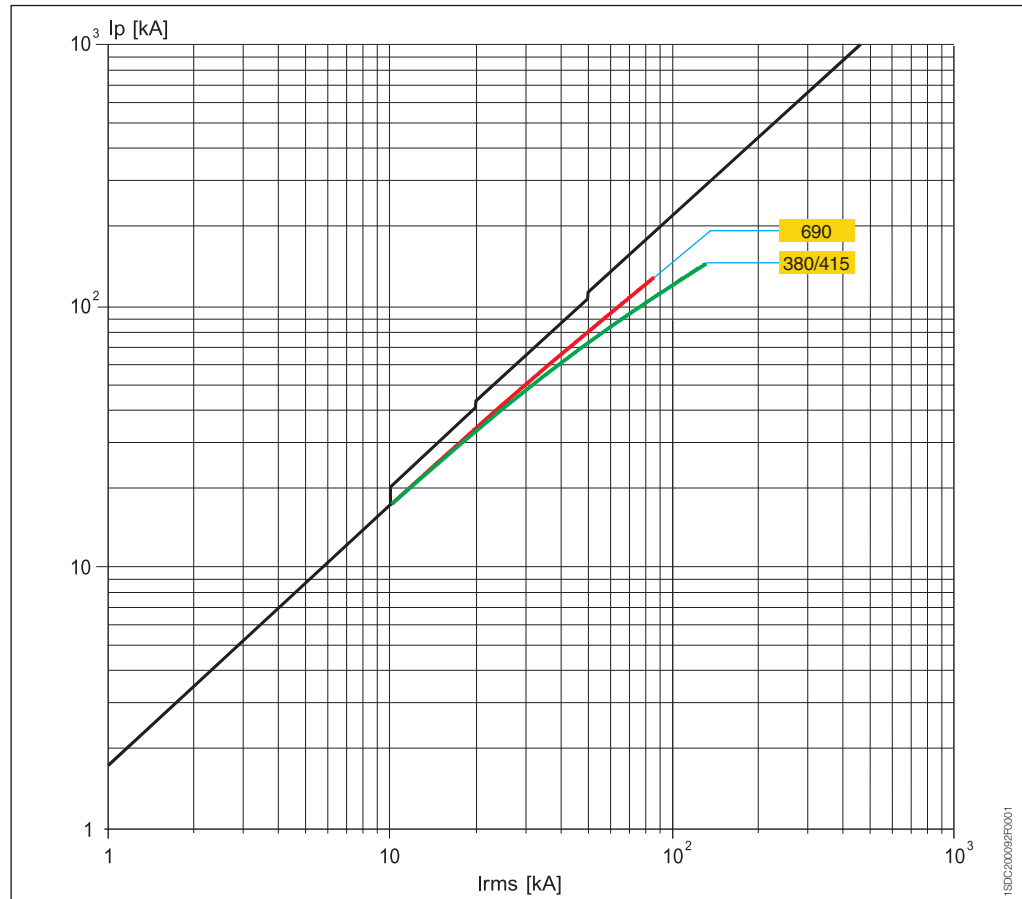

E2L

Specific let-through energy curves

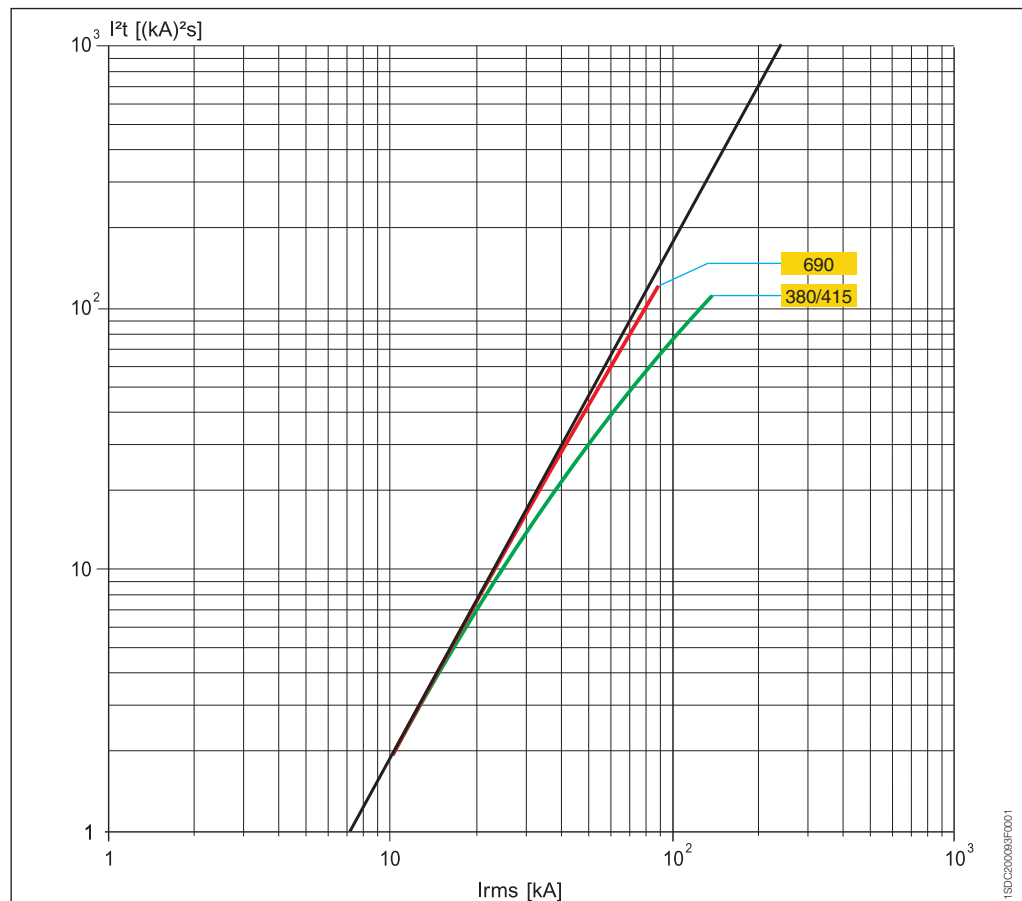

Irms prospective symmetrical short-circuit current
Ip peak current
I²t specific let-through energy at the voltages indicated

E3L

Current-limiting curves

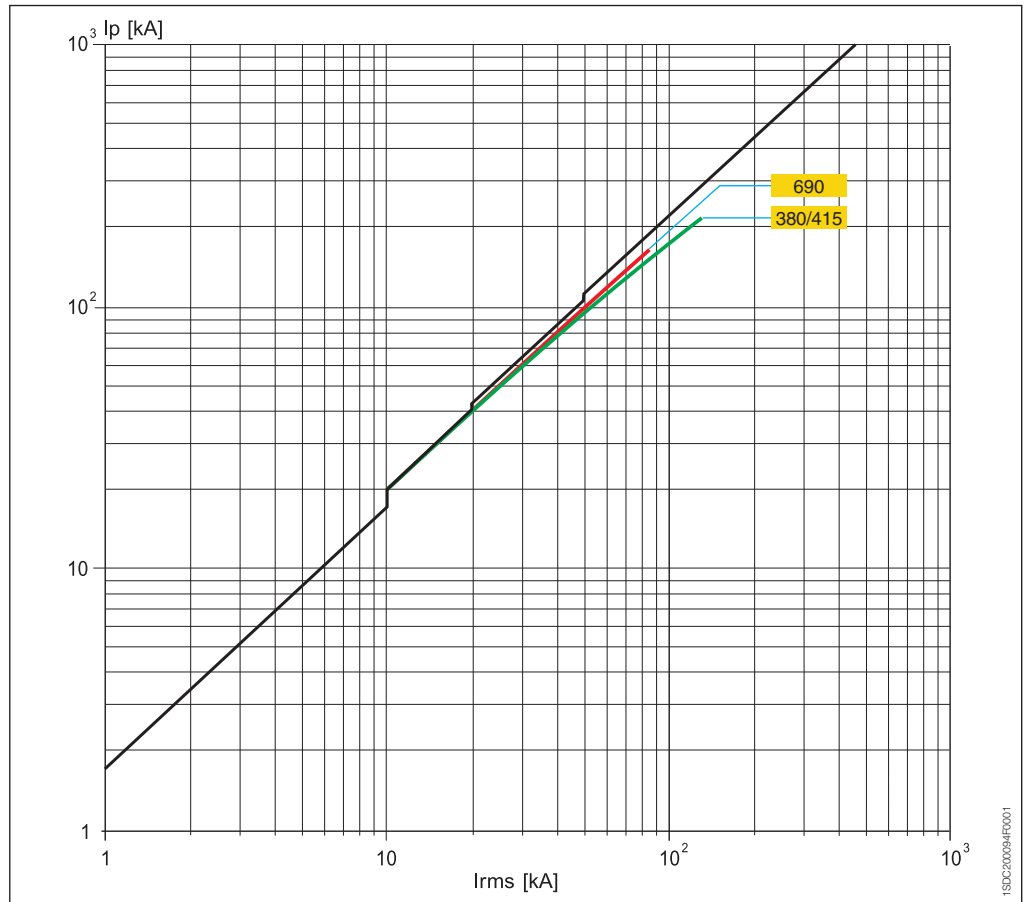

E3L

Specific let-through energy curves

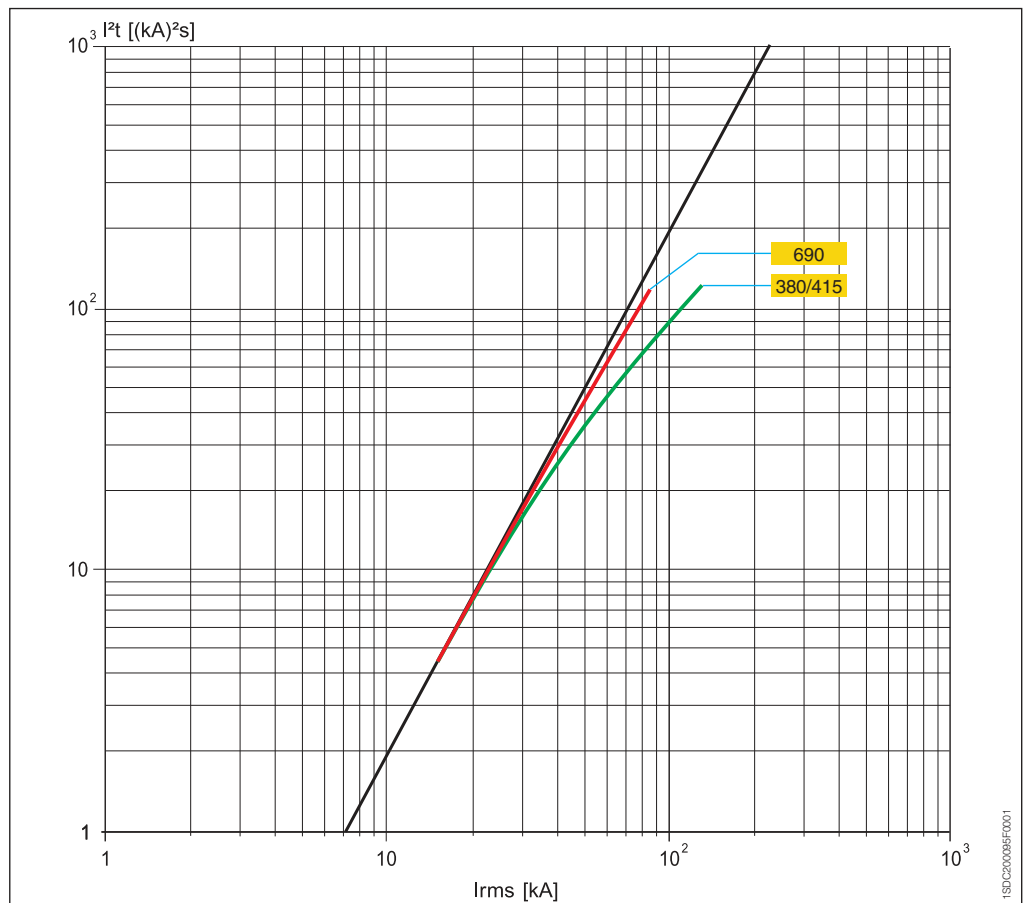

- I_{rms}** prospective symmetrical short-circuit current
- I_p** peak current
- I^2t** specific let-through energy at the voltages indicated

Emmax





Overcurrent releases and related accessories

Contents

Protection trip units and trip curves

PR121/P	4/2
PR122/P	4/9
PR123/P	4/24

Accessories for protection trip units

PR120/K Internal Module	4/35
PR120/V Measurement Module	4/35
PR120/D-M Communication Module	4/36
PR120/D-BT Wireless Communication Module	4/36
BT030 Communication unit	4/36
PR030/B power supply unit	4/36
Interface from front of HMI030 panel	4/36
SACE PR010/T configuration test unit	4/37
Flex Interface	4/38

Communication devices and systems

Industrial networking and ABB SACE Emax	4/40
PR120/D-M	4/42
BT030	4/42
EP 010 – FBP	4/42
SD-View 2000	4/44
SD-TestBus2	4/46





Protection trip units and trip curves

PR121/P

Characteristics

PR121/P is the new basic and complete trip unit for the Emax series. The complete range of protection functions together with the wide combination of thresholds and trip times offered make it suitable for protecting a wide range of alternating current installation. In addition to protection functions the unit is provided with multifunction LED indicators. Furthermore, PR121/P allows connection to external devices enhancing its advanced characteristics like remote signalling and monitoring, or remote supervision display.

4

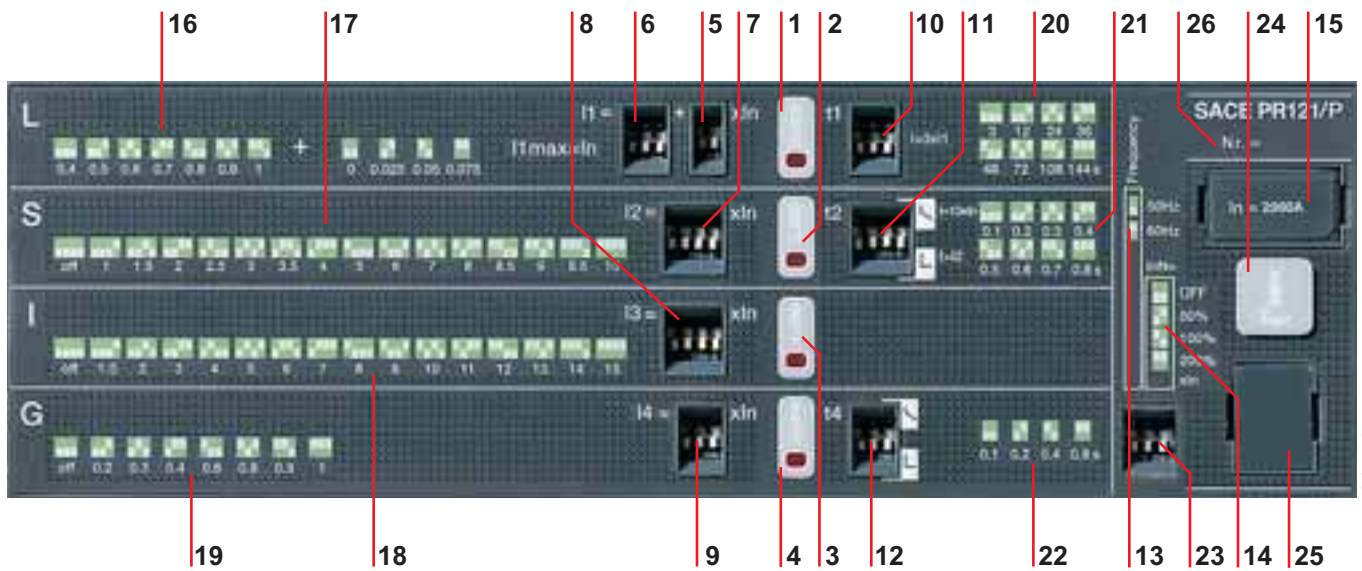

Caption

- | | | | |
|--|--|---|---|
| <ul style="list-style-type: none"> 1 LED signalling Alarm for protection function L 2 LED signalling Alarm for protection function S 3 LED signalling Alarm for protection function I 4 LED signalling Alarm for protection function G 5 DIP switches for fine setting current threshold I1 6 DIP switches for main setting current threshold I1 7 DIP switches for setting current threshold I2 8 DIP switches for setting current threshold I3 | <ul style="list-style-type: none"> 9 DIP switches for setting current threshold I4 10 DIP switches for setting trip time t1 (type of curve) 11 DIP switches for setting trip time t2 (type of curve) 12 DIP switches for setting trip time t4 (type of curve) 13 Indication of the DIP switch position for network frequency 14 Indication of the DIP switch position for Neutral protection setting 15 Rating plug 16 Indication of the DIP switch positions for the various current thresholds values I1 | <ul style="list-style-type: none"> 17 Indication of the DIP switch positions for the various current threshold values I2 18 Indication of the DIP switch positions for the various current threshold values I3 19 Indication of the DIP switch positions for the various current threshold values I4 20 Indication of DIP switch positions for the various time settings t1 21 Indication of DIP switch positions for the various time settings t2 22 Indication of DIP switch positions for the various time settings t4 23 DIP switch for setting network frequency and neutral protection setting | <ul style="list-style-type: none"> 24 Trip cause indication and trip test pushbutton 25 Test connector for connecting or testing the trip unit through an external device (PR030/B battery unit, BT030 wireless communication unit and SACE PR010/T unit) 26 Serial number of protection trip unit |
|--|--|---|---|

Operation and protection functions

Protection functions

The PR121 trip unit offers the following protection functions:

- overload (L)
- selective short-circuit (S)
- instantaneous short-circuit (I)
- earth fault (G).

Overload (L)

The inverse long time-delay trip overload protection L is type $I^2t = k$; 25 current thresholds and 8 curves are available. Each curve is identified by the trip time in relation to the current $I = 3 \times I_1$ ($I_1 =$ set threshold).

Selective short-circuit (S)

The selective short-circuit protection S can be set with two different types of curves with a trip time independent of the current ($t = k$) or with a constant specific let-through energy ($t = k/I^2$).

15 current thresholds and 8 curves are available, allowing a fine setting. Each curve is identified as follows:

- for curves $t = k$ by the trip time for $I > I_2$
- for curves $t = k/I^2$ by the trip time for $I = 10 \times I_n$ ($I_n =$ rated current of the circuit-breaker).

The function can be excluded by setting the DIP switches to the combination labelled "OFF".

Adjustable instantaneous short-circuit (I)

The protection I offers 15 trip thresholds and can be excluded (dip switches in "OFF" position).

Earth fault (G)

The earth fault protection G (which can be excluded) offers 7 current thresholds and

4 curves. Each curve is identified by the time t_4 in relation to current I_4 . As per S protection the trip time can be chosen independent of the current ($t = k$) or with a constant specific let-through energy ($t = k/I^2$).

Note: the current values above which G is disabled are indicated in the installation manual.

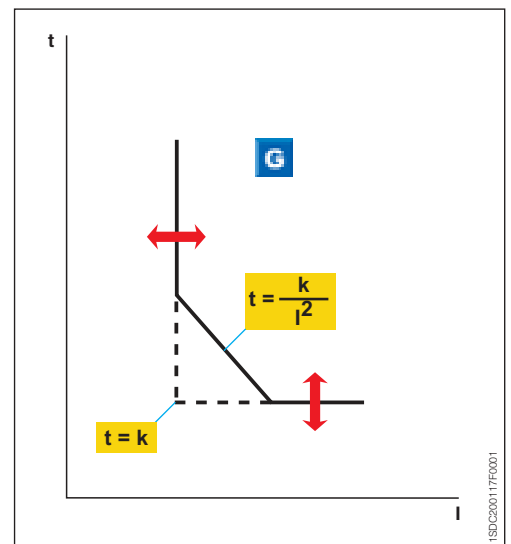
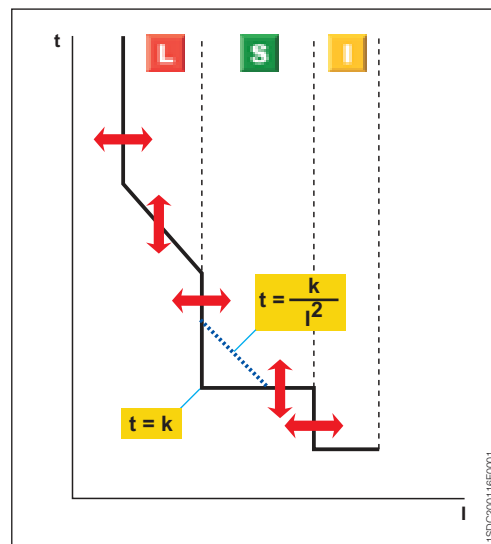



Protection trip units and trip curves

PR121/P

User interface

The user communicates directly with the trip unit in the trip parameter preparation stage by means of the dip switches.

Up to four LEDs (according to the version) are also available for signalling.

These LEDs (one for each protection) are active when:

- a protection is timing. For protection L the prealarm status is also shown;
- a protection has tripped (the corresponding LED is activated by pressing the “Info/Test” pushbutton);
- a failure in connection of a current sensor or in the opening solenoid is detected. The indication is active when the unit is powered (through current sensors or an auxiliary power supply)
- wrong rating plug for the circuit-breaker.

The protection tripped indication works even with the circuit-breaker open, without the need for any internal or external auxiliary power supply. This information is available for 48 hours of inactivity after the trip and is still available after reclosing. If the query is made more than 48 hours later it is sufficient to connect a PR030/B battery unit, PR010/T, or a BT030 wireless communication unit.

Communication

By means of the BT030 wireless communication unit, PR121/P can be connected to a pocket PC (PDA) or to a personal computer, extending the range of information available for the user. In fact, by means of ABB SACE's SD-Pocket communication software, it is possible to read the values of the currents flowing through the circuit-breaker, the value of the last 20 interrupted currents, and the protection settings.

PR121 can also be connected to the optional external PR021/K signalling unit, for the remote signalling of protections alarms and trips, and to HMI030, for the remote user interfacing.

Setting the neutral

Protection of the neutral can be set at 50%, 100% or 200% of the phase currents. Settings above 50% can be selected for E1-E2-E3-E4/f and E6/f. In particular, setting the neutral at 200% of phase current requires protection L to be set at $0.5I_n$ in order to respect the current-carrying capacity of the circuit-breaker. The user can also switch the neutral protection OFF. When three-poles circuit-breakers with external neutral current sensor are used, a setting above 100% for the neutral does not require any reduction in the L setting.

Test Function

The Test function is carried out by means of the info/Test pushbutton and the PR030/B battery unit (or BT030) fitted with a polarized connector housed on the bottom of the box, which allows the device to be connected to the test connector on the front of PR121/P trip units.

The PR121/P electronic trip unit can be tested by using the SACE PR010/T test and configuration unit by connecting it to the TEST connector.

Versions available

The following versions are available:



PR121/P LI

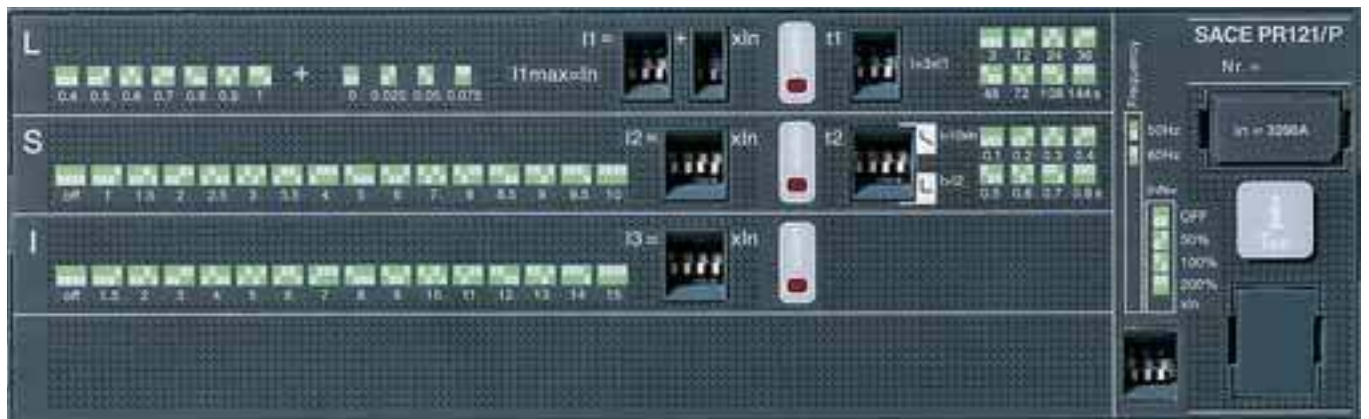

PR121/P LSI

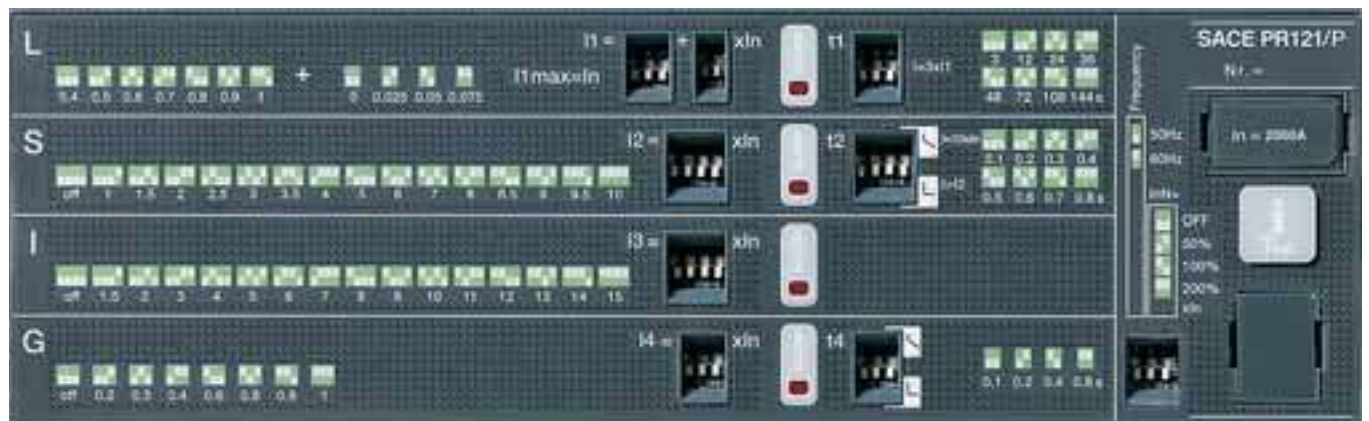

PR121/P LSIG



Protection trip units and trip curves

PR121/P

Protection functions and setting values - PR121

Function	Trip threshold	Trip time*	Poss. excl.	Relation t=f(I)
L Overload protection	I1= 0.4 - 0.425 - 0.45 - 0.475 - 0.5 - 0.525 - 0.55 - 0.575 - 0.6 - 0.625 - 0.65 - 0.675 - 0.7 - 0.725 - 0.75 - 0.775 - 0.8 - 0.825 - 0.85 - 0.875 - 0.9 - 0.925 - 0.95 - 0.975 - 1 x In	With current If = 3 x I1 t1 = 3 - 12 - 24 - 36 - 48 - 72 - 108 - 144 s ⁽¹⁾	—	t=k/I ²
Tolerance ⁽²⁾	Release between 1.05 and 1.2 x I1	± 10% If ≤ 6 x In ± 20% If > 6 x In		
S Selective short-circuit protection	I2= 1 - 1.5 - 2 - 2.5 - 3 - 3.5 - 4 - 5 - 6 - 7 - 8 - 8.5 - 9 - 9.5 - 10 x In	With current If > I2 t2 = 0.1 - 0.2 - 0.3 - 0.4 - 0.5 - 0.6 - 0.7 - 0.8 s	■	t=k
Tolerance ⁽²⁾	± 7% If ≤ 6 x In ± 10% If > 6 x In	The better of the two figures: ± 10% or ± 40 ms		
	I2= 1 - 1.5 - 2 - 2.5 - 3 - 3.5 - 4 - 5 - 6 - 7 - 8 - 8.5 - 9 - 9.5 - 10 x In	With current If = 10 x In t2 = 0.1 - 0.2 - 0.3 - 0.4 - 0.5 - 0.6 - 0.7 - 0.8 s	■	t=k/I ²
Tolerance ⁽²⁾	± 7% If ≤ 6 x In ± 10% If > 6 x In	± 15% If ≤ 6 x In ± 20% If > 6 x In		
I Instantaneous short-circuit protection	I3= 1.5 - 2 - 3 - 4 - 5 - 6 - 7 - 8 - 9 - 10 - 11 - 12 - 13 - 14 - 15 x In	Instantaneous	■	t=k
Tolerance ⁽²⁾	± 10%	≤ 30 ms		
G Earth fault protection	I4= 0.2 - 0.3 - 0.4 - 0.6 - 0.8 - 0.9 - 1 x In	With current If > I4 t4 = 0.1 - 0.2 - 0.4 - 0.8 s	■	t=k
Tolerance ⁽²⁾	± 7%	The better of the two figures: ± 10% or ± 40 ms		
	I4= 0.2 - 0.3 - 0.4 - 0.6 - 0.8 - 0.9 - 1 x In	t4 = 0.1 @ 4.47 I4, t4 = 0.2 @ 3.16 I4, t4 = 0.4 @ 2.24 I4, t4 = 0.8 @ 1.58 I4	■	t=k/I ²
Tolerance ⁽²⁾	± 7%	± 15%		

If = fault current

* Referring to the electronics

(1) The minimum trip time is 1 s, regardless of the type of curve set (self-protection)

(2) These tolerances are valid in the following conditions:

- self-supplied trip unit at full power (without start-up)
- two- or three-phase power supply
- trip time set ≥ 100 ms

The following tolerance values apply in all cases not covered by the above:

Trip threshold	Trip time
S ± 10%	± 20%
I ± 10%	± 20%
G ± 15%	± 20%

Power supply

The unit does not require an external power supply either for protection functions or for alarm signalling functions. It is self-supplied by means of the current sensors installed on the circuit-breaker. For it to operate, the three phases must be loaded at 70A for E1, E2 and E3 and at 140A for E4 and E6. An external power supply can be connected in order to activate additional features, and in particular for connection to external devices: HMI030, and PR021/K.

PR121/P	
Auxiliary power supply (galvanically insulated)	24 V DC ± 20%
Maximum ripple	5%
Inrush current @ 24V	~10 A for 5 ms
Rated power @ 24V	~2 W

Functions L-I

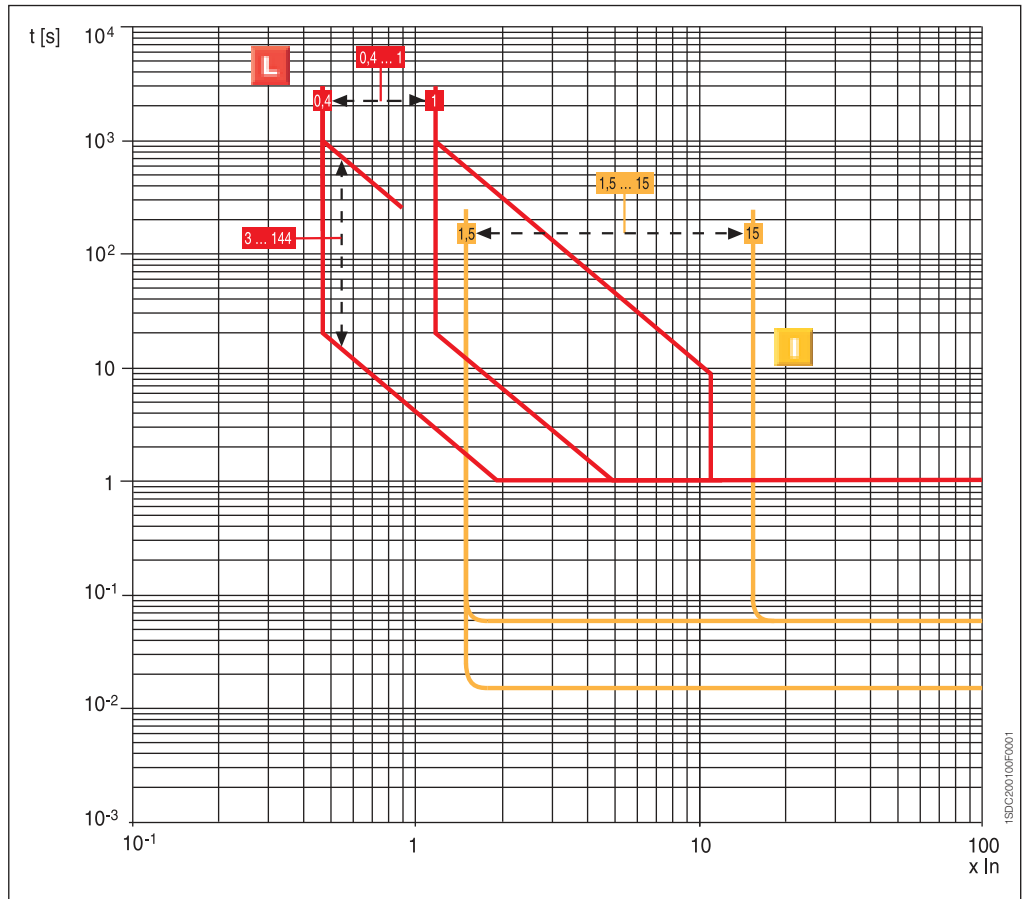

4

Functions L-S-I

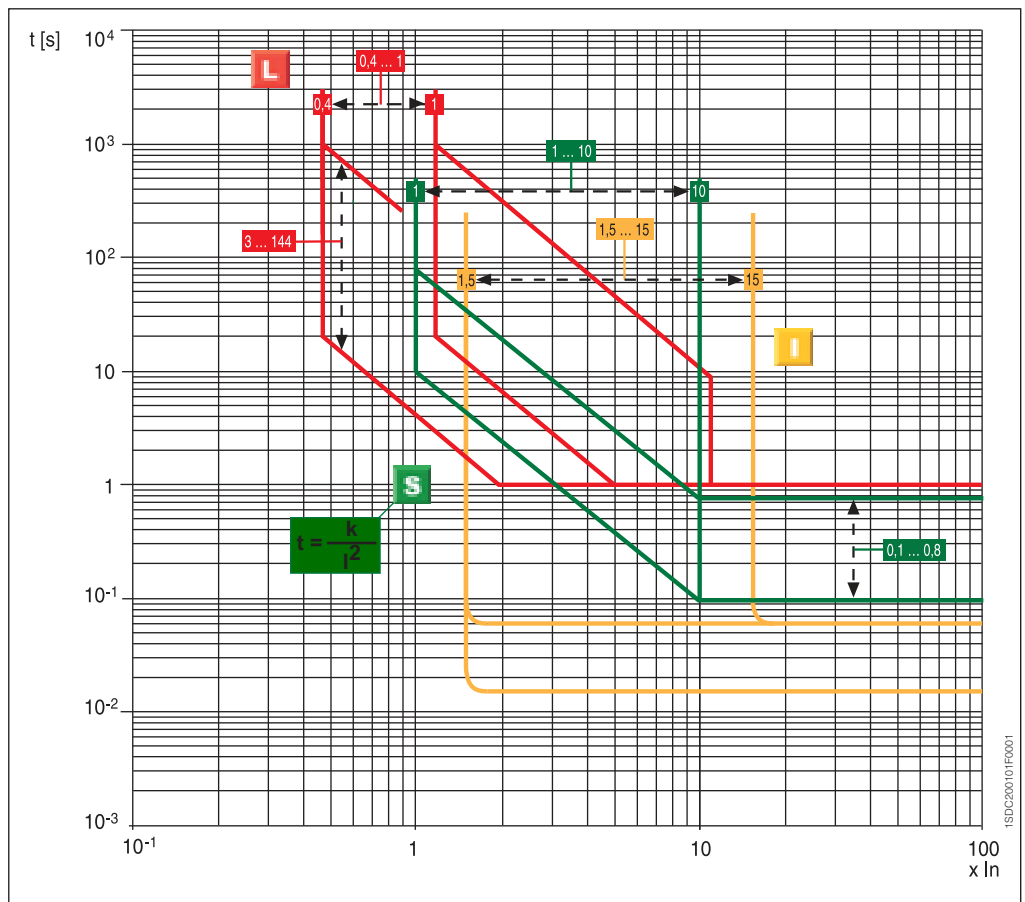

Threshold and trip times tolerances page 4/6



Protection trip units and trip curves

PR121/P

Functions L-S-I

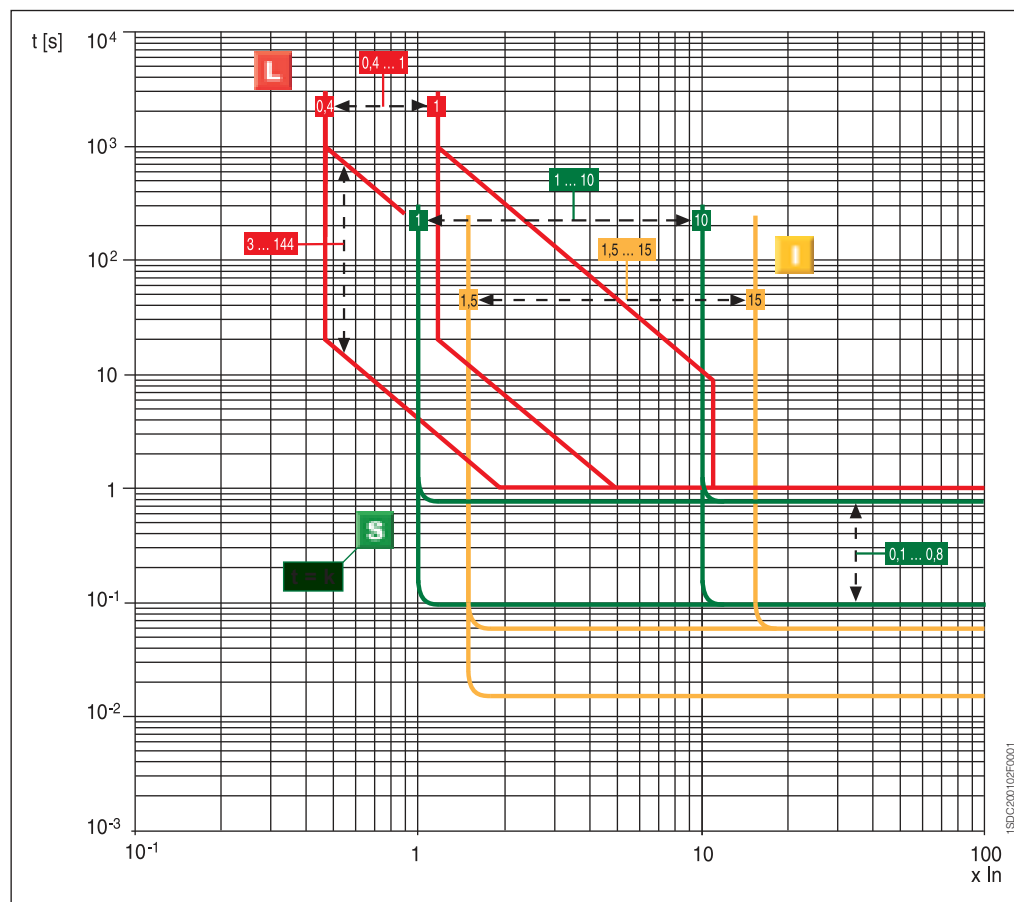

4

Function G

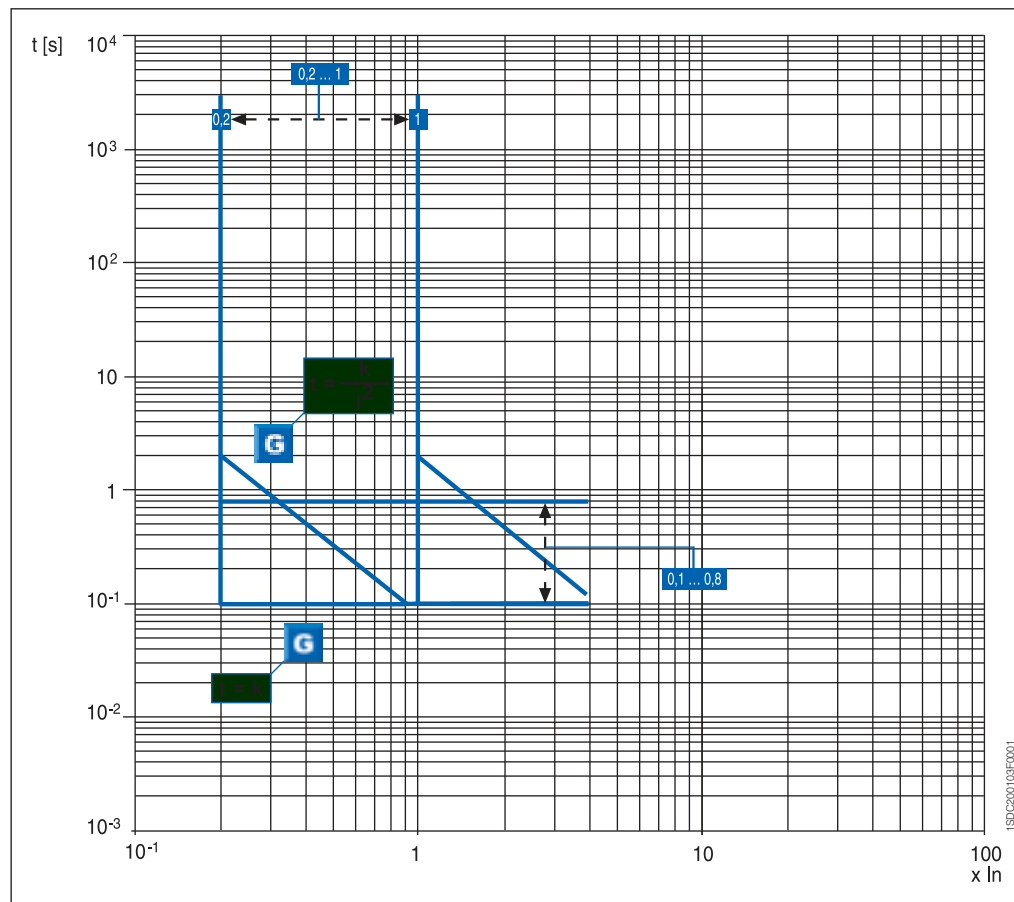

Threshold and trip times tolerances page 4/6

Protection trip units and trip curves

PR122/P

Characteristics

The SACE PR122 trip unit is a sophisticated and flexible protection system based on a state-of-the-art microprocessor and DSP technology. Fitted with the optional internal PR120/D-M dialogue unit, PR122/P turns into an intelligent protection, measurement and communication device, based on the Modbus® protocol. By means of the PR120/D-M, PR122/P can also be connected to the ABB EP010 Fieldbus plug adapter, which makes it possible to choose among several different networks, such as Profibus and DeviceNet.

The new PR122/P is the result of ABB SACE's experience in designing protection trip units. The exhaustive range of settings makes this protection unit ideal for general use in any type of installation, from distribution to the protection of motors, transformers, drives and generators. Access to information and programming using a keyboard and graphic liquid crystal display is extremely simple and intuitive. The interface is now common to PR122/P and PR123/P in order to give to the user maximum ease of use.

An integrated ammeter and many other additional features are provided over and above the protection functions. These additional functions can be further increased with addition on board of the dialogue, signalling, measurement, and wireless communication units.

Functions S and G can operate with a time delay independent of the current ($t = k$) or with an inverse time delay (constant specific let-through energy: $I^2t = k$), as required.

Protection against earth faults can also be obtained by connecting the PR122 trip unit to an external toroid located on the conductor that connects the transformer star centre to earth (homopolar toroid).

All the thresholds and trip curve delays of the protection functions are stored in special memories which retain the information even when no power is supplied.

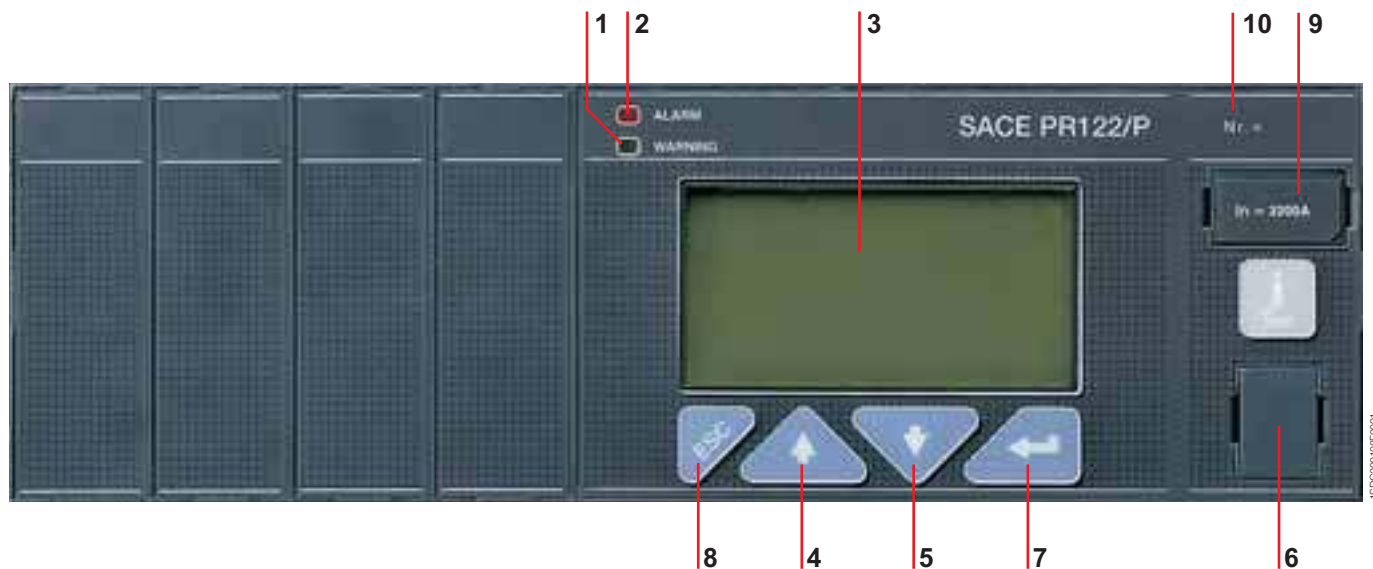

Caption

- | | | |
|----------------------------|---|--|
| 1 LED Warning indicator | 6 Test connector for connecting or testing the trip unit by means of an external device (PR030/B battery unit, BT030 wireless communication unit and SACE PR010/T unit) | change pages |
| 2 Alarm LED | 7 ENTER button to confirm data or | 8 Button to exit submenus or cancel operations (ESC) |
| 3 Rear-lit graphic display | | 9 Rating plug |
| 4 Cursor UP button | | 10 Serial number of protection trip unit |
| 5 Cursor DOWN button | | |



Protection trip units and trip curves

PR122/P

Operation, protection functions and self-test

Basic Protection functions

The PR122 trip unit offers the following protection functions (according to the version):

- overload (L)
- selective short-circuit (S)
- instantaneous short-circuit (I)
- earth fault (G)⁽²⁾
- phase unbalance (U)
- self-protection against over-temperature (OT)
- thermal memory for functions L and S
- zone selectivity for functions S and G
- residual current (Rc) with external toroid
- source ground return with external toroid

sion. The neutral protection can be excluded or set to 100% for E1, E2, E3, E4/f and E6/f. In installations where very high harmonics occur, the resulting current at the neutral can be higher than that of the phases. Therefore it is possible to set the neutral protection at 150% or 200% of the value set for the phases. In this case it is necessary to reduce the setting of protection L accordingly⁽¹⁾.

The table below lists the neutral settings for the various possible combinations between type of circuit-breaker and the threshold I1 setting.

avoids untimely tripping caused by the high inrush currents of certain loads (motors, transformers, lamps).

The start-up phase lasts from 100 ms to 1.5 s, in steps of 0.05 s. It is automatically recognized by the PR122 trip unit as follows:

- when the circuit-breaker closes with the trip unit self-supplied;
- when the peak value of the maximum current exceeds $0.1 \times I_n$. A new start-up becomes possible after the current has fallen below the threshold of $0.1 \times I_n$, if the trip unit is supplied from an external source.

Setting the neutral

In PR122/P, and PR123/P as well, the neutral protection is 50% of the value set for phase protection in the standard ver-

Start-up function

The start-up function allows protections S, I and G to operate with higher trip thresholds during the start-up phase. This

4

Adjustable neutral protection settings

Circuit-breaker model	Threshold I1 settings (overload protection)		
	$0.4 < I1 < 0.5$	$0.5 < I1 < 0.66$	$0.66 < I1 < 1.0$
E1B-N	0-50-100-150-200%	0-50-100-150%	0-50-100%
E2S-N-S-L	0-50-100-150-200%	0-50-100-150%	0-50-100%
E3N-S-H-V-L	0-50-100-150-200%	0-50-100-150%	0-50-100%
E4S-H-V	0-50-100%	0-50%	0-50%
E4S/f-H/f	0-50-100-150-200%	0-50-100-150%	0-50-100%
E6H-V	0-50-100%	0-50%	0-50%
E6H/f	50-100-150-200%	0-50-100-150%	0-50-100%

(*) The setting $I1 = 1$ indicates the maximum overload protection setting. The actual maximum setting allowable must take into account any derating based on temperature, the terminals used and the altitude (see the "Installations" chapter)

(1) When three-pole circuit-breakers with external neutral current sensor are used, a setting above 100% for the neutral does not require any reduction in the L setting up to I_n .

(2) The current values above which G is disabled are indicated in the installation manual.

Phase unbalance protection U

Protection function U against phase unbalance is used in those situations requiring particularly precise control over missing and/or unbalanced phase currents, only giving the pre-alarm signal. This function can be excluded.

Protection against overtemperature

The range of SACE PR122 trip units allows the presence of abnormal temperatures, which could cause temporary or continuous malfunctions of the microprocessor, to be signalled to the user.

The user has the following signals or commands available:

- lighting up of the “Warning” LED when the temperature is higher than 70 °C (temperature at which the microprocessor is still able to operate correctly)
- lighting up of the “Alarm” LED when the temperature is higher than 85 °C (temperature above which the microprocessor can no longer guarantee correct operation) and, when decided during the unit configuration stage, simultaneous opening of the circuit-breaker with indication of the trip directly on the display, as for the other protections.

Zone selectivity for protections S and G

Zone selectivity is one of the most advanced methods for making co-ordination of the protections: by using this protection philosophy, it is possible to reduce the trip times of the protection closest to the fault in relation to the times foreseen by time selectivity, of which zone selectivity is an evolution.

Zone selectivity is applicable to protection functions S and G, even contemporarily and is available as standard on the PR122. The word zone is used to refer to the part of an installation between two circuit-breakers in series (see picture beside). Protection is provided by connecting all of the zone selectivity outputs of the trip units belonging to the same zone together and taking this signal to the zone selectivity input of the trip unit immediately to the supply side.

Each circuit-breaker that detects a fault communicates this to the circuit-breaker on the supply side using a simple connection wire. Therefore the fault zone is the zone immediately to the load side of the circuit-breaker that detects the fault, but does not receive any communication from those on the load side. This circuit-breaker opens without waiting for the set time-delay.

ABB SACE provides important calculation tools to facilitate the work of designers in coordinating protection devices, including the Slide rule kits, DOCWin and CAT software packages and updated coordination charts.

The zone selectivity function S and G can be activated or deactivated using the keyboard.

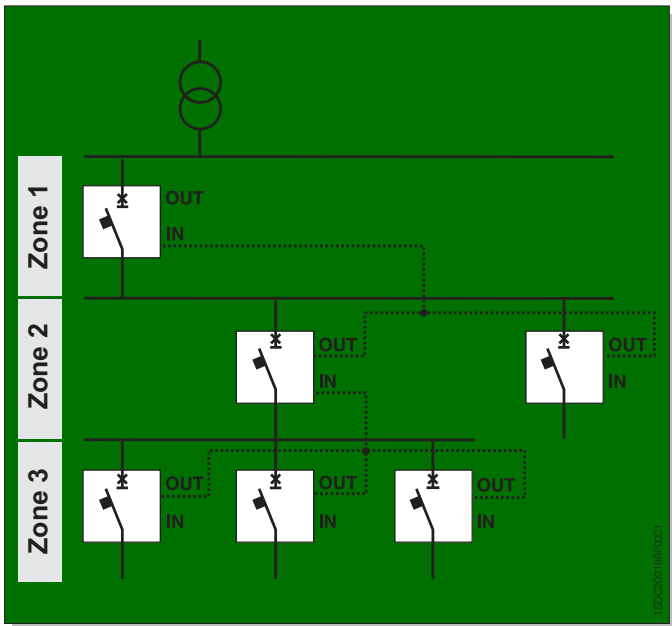



Protection trip units and trip curves

PR122/P

Self-diagnosis

The PR122 range of trip units contains an electronic circuit which periodically checks the continuity of internal connections (opening solenoid or each current sensor, including the Source Ground Return when present).

In the case of a malfunction an alarm message appears directly on the display. The Alarm is highlighted by the Alarm LED as well.

Residual Current

Different solutions are available for integrated residual current protection. The basic choice is PR122/P-LSIRc, which has all the characteristics of PR122/P-LSI and residual current protection as well. When additional features are required, the solution is PR122/P LSIG with an additional PR120/V module (see next paragraph). Using this configuration, residual current protection is added to a unit, having the features of PR122/P-LSI and all the add-ons described for the PR120/V module, such as voltage protection and advanced measurement functions.

Residual current protection acts by measuring the current from the external dedicated toroid and must be ordered separately. Rc protection can be activated only if the special rating plug for residual current protection is present.

Test Functions

Once enabled from the menu, the “info/Test” pushbutton on the front of the trip unit allows correct operation of the chain consisting of the microprocessor, opening solenoid and circuit-breaker tripping mechanism to be checked.

The control menu also includes the option of testing correct operation of the display, signalling LEDs, and electrical contacts of the PR120/K trip unit.

When the auxiliary power supply is not present, the PR030/B unit can perform the trip test.

By means of the front multi-pin connector it is possible to apply a SACE PR010/T Test unit which allows the functions of the PR121, PR122 and PR123 ranges of trip units to be tested and checked.

User interface

The human-machine interface (HMI) of the device is made up of a wide graphic display, LEDs, and browsing pushbuttons. The interface is designed to provide maximum simplicity.

The language can be selected from among five available options: Italian, English, German, French and Spanish.

As in the previous generation of trip units, a password system is used to manage the “Read” or “Edit” modes. The default password, 0001, can be modified by the user.

The protection parameters (curves and trip thresholds) can be set directly via the HMI of the device. The parameters can only be changed when the trip unit is operating in “Edit” mode, but the information available and the parameter settings can be checked at any time in “Read” mode.

When a communication device (internal PR120/D-M and PR120/D-BT modules or external BT030 device) is connected, it is possible to set parameters simply by downloading them into the unit (over the network for PR120/D-M, by using a PDA or a notebook for PR120/D-BT and BT030). Parameterisation can then be carried out quickly and automatically in an error-free way by transferring data directly from DocWin.

Indicator LEDs

LEDs on the front panel of the trip unit are used to indicate all the pre-alarms (“WARNING”) and alarms (“ALARM”). A message on the display always explicitly indicates the type of event concerned.

Example of events indicated by the “WARNING” LED:

- unbalance between phases;
- pre-alarm for overload ($L1 > 90\%$);
- first temperature threshold exceeded (70 °C);
- contact wear beyond 80%;
- phase rotation reversed (with optional PR120/V)

Example of events indicated by the "ALARM" LED:

- overload (may begin from $1.05 \times I_n < I < 1.3 \times I_n$, in accordance with the standard IEC 60947-2);
- timing of function L;
- timing of function S;
- timing of function G;
- second temperature threshold exceeded (85 °C);
- contact wear 100%;
- timing of Reverse Power flow protection (with optional PR120/V);

Data logger

By default PR122/P, as well as PR123/P, is provided with the Data Logger function, that automatically records in a wide memory buffer the instantaneous values of all the currents and voltages. Data can be easily downloaded from the unit by means of TestBus2 application using a Bluetooth port and can be transferred to any personal computer for elaboration. The function freezes the recording whenever a trip occurs, so that a detailed analysis of faults can be easily performed. SD-Pocket and TestBus2 allow also reading and downloading of all the others trip information.

- Number of channels: 8
- Maximum sampling rate: 4800 Hz
- Maximum sampling time: 27 s (@ sampling rate 600 Hz)
- 64 events tracking

Trip information and opening data

In case a trip occurs PR122/P and PR123/P store all the needed information:

- Protection tripped
- Opening data (current)
- Time stamp (guaranteed with auxiliary supply or self-supply with power failure no longer than 48h)

By pushing the "info/Test" pushbutton the trip unit shows all these data directly on display.

No auxiliary power supply is needed. The information is available to user for 48 hours with the circuit breaker open or without current flowing.

The information of the latest 20 trips are stored in memory.

If the information can be furthermore retrieved more than 48 hours later, it is sufficient to connect a PR030/B battery unit or a BT030 wireless communication unit.

Load control

Load control makes it possible to engage/disengage individual loads on the load side before the overload protection L is tripped, thereby avoiding unnecessary trips of the circuit-breaker on the supply side. This is done by means of contactors or switch-disconnectors (externally wired to the trip unit), controlled by the PR122/P by PR120/K internal contacts, or by PR021/K unit.

Two different Load Control schemes can be implemented:

- disconnection of two separate loads, with different current thresholds
- connection and disconnection of a load, with hysteresis

Current thresholds and trip times are smaller than those available for selection with protection L, so that load control can be used to prevent overload tripping.

Internal PR120/K or external PR021/K accessory unit is required for Load Control. The function is only active when an auxiliary power supply is present.



Protection trip units and trip curves

PR122/P

PR120/V Measurement Module

This optional internal module, installed in PR122 (standard in PR123), allows the trip unit to measure the phase and neutral voltages and to process them in order to achieve a series of features, in terms of protection and measurement.

PR120/V does not normally require any external connection or Voltage Transformer, since it is connected internally to the lower terminals of Emax. When necessary, the connection of voltage pick-ups can be moved to any other points (i.e. upper terminals), by using the alternative connection located in the terminal box. The module is provided with a sealable switch-disconnector for the dielectric test. PR120/V is able to energize the PR122 while line voltage input is above 85V. The use of Voltage Transformers is mandatory for rated voltages higher than 690V.

Voltage transformers shall have burdens equal to 10VA and accuracy class 0.5 or better.



1SDC200114R0001

Additional Protections with PR120/V:

- UnderVoltage (UV) protection
- Overvoltage (OV) protection
- Residual voltage (RV) protection
- Reverse power (RP) protection
- Underfrequency (UF) protection
- Overfrequency (OF) protection

All the above indicated protections can be excluded, although it is possible to leave only the alarm active when required.

With the circuit-breaker closed, these protections also operate when the trip unit is self-supplied. With the circuit-breaker open, they operate when the auxiliary power supply (24V DC or PR120/V) is present: in this case the trip unit will indicate the “ALARM” status.

Voltage protections UV, OV, RV

With the PR120/V module, the PR122/P trip unit is able to provide the undervoltage and overvoltage protection (UV, OV) and the residual voltage protection (RV). The residual voltage protection RV identifies interruptions of the neutral (or of the earthing conductor in systems with earthed neutral) and faults that shift the star centre in systems with insulated neutral (e.g. large earth faults). The star centre shift is calculated as a vectorial sum of the phase voltages.

Reverse power protection RP

Reverse power protection is especially suitable for protecting large machines such as motors and generators. The PR122 with the PR120/V module can analyse the direction of the active power and open the circuit-breaker if the direction is opposite to that of normal operation. The reverse power threshold and the trip time are adjustable.

Frequency protections UF, OF

The frequency protections detect the variation of network frequency above adjustable thresholds, generating an alarm or opening the circuit-breaker. It is a protection typically needed in an isolated network, i.e. powered by a genset.

Measurement function

The current measurement function (ammeter) is present on all versions of the SACE PR122 unit. The display shows histograms showing the currents of the three phases and neutral on the main page. Furthermore, the most loaded phase current is indicated in numerical format. Earth fault current, where applicable, is shown on a dedicated page.

The latter current value takes on two different meanings depending on whether the external toroidal transformer for the “Source Ground Return” function or the internal transformer (residual type) is connected.

The ammeter can operate either with self-supply or with an auxiliary power supply voltage. In the latter case the display is rear-lit and the ammeter is active even at current levels lower than 160A. Accuracy of the ammeter measurement chain (current sensor plus ammeter) is no more than 1.5% in the 30% - 120% current interval of I_n .

- Currents: three phases (L1, L2, L3), neutral (Ne) and earth fault;
- Instantaneous values of currents during a period of time (data logger);
- Maintenance: number of operations, percentage of contact wear, opening data storage (last 20 trips and 80 events).

When the optional PR120/V is connected the following additional measurement function are present:

- Voltage: phase-phase, phase-neutral and residual voltage
- Instantaneous values of voltages during a period of time (data logger);
- Power: active, reactive and apparent
- Power factor
- Frequency and peak factor
- Energy: active, reactive, apparent, counter

Versions available

The following versions are available:



PR122/P LI-LSI-LSIG-LSIRc



Protection trip units and trip curves

PR122/P

Protection functions and setting values - PR122

Function	Trip threshold	Threshold steps	Trip Time	Time Step	Poss. excl.	Relation t=f(I)	Thermal memory	Zone selectivity
L Overload protection	I1= 0.4...1 x In	0.01 x In	With current If = 3 x I1 t1= 3 s...144 s ± 10% If ≤ 6 x In ± 20% If > 6 x In	3 s ⁽¹⁾	—	t=k/I ²	■	—
	Tolerance ⁽²⁾ Release between 1.05 and 1.2 x I1							
Tolerance ⁽²⁾	I1= 0.4...1 x In Release between 1.05 ... 1.2 x I1	0,01 x In	With If = 3xI1 ⁽⁴⁾ ; t1= 3 s...144 s ± 20% If > 5 x I1 ± 30% 2xI1 ≤ If ≤ 5 x I1 In	3 s ⁽¹⁾	—	t=k(α) ⁽⁵⁾ α = 0.2-1-2	—	—
S Selective short-circuit protection ⁽¹⁾	I2= 0.6...10 x In	0.1 x In	With current If > I2 t2= 0.05 s...0.8 s t2sel= 0.04 s...0.2 s	0.01 s 0.01 s	■	t=k	—	■
	Tolerance ⁽²⁾ ± 7% If > 6 x In ± 10% If > 6 x In		The better of the two figures: ± 10% or ± 40 ms					
	Tolerance ⁽²⁾	I2= 0.6...10 x In ± 7% If > 6 x In ± 10% If > 6 x In	0.1 x In	With current If = 10 x In t2= 0.05 s...0.8 s ± 15% If > 6 x In ± 20% If > 6 x In	0.01 s	■	t=k/I ²	■
I Instantaneous short-circuit protection	I3= 1.5...15 x In	0.1 x In	Instantaneous	—	■	t=k	—	—
	Tolerance ⁽²⁾ ± 10%		≤ 30 ms					
G Earth fault protection	I4 ⁽⁶⁾ = 0.1...1 x In	0.02 x In	With current If > I4 t4= 0.1 s...1 s t4sel= 0.04 s...0.2 s	0.05 s 0.01 s	■	t=k	—	■
	Tolerance ⁽²⁾ ± 7%		The better of the two figures: ± 10% or ± 40 ms					
	Tolerance ⁽²⁾	I4= 0.1...1 x In ± 7%	0.02 x In	I4= 0.1 s...1 s (with If=4xI4) ± 15%	0.05 s	■	t=k/I ²	—
Rc Residual Current protection ⁽⁷⁾	I _d = 3-5-7-10-20-30 A		t _d = 0.06-0.1-0.2-0.3-0.4-0.5-0.8 s ⁽³⁾		■	t=k	—	—
	Tolerance ⁽²⁾ ± 10%							
OT Protection against overtemperature	may not be set		instantaneous		—	t _{emp} =k	—	—
U Phase unbalance protection	I ₆ = 5%...90%	5%	t ₄ = 0.5 s...60 s	0.5 s	■	t=k	—	—
	Tolerance ⁽²⁾ ± 10%		The better of the two figures: ± 20% or ± 100 ms					

If = fault current

* G=0.1xIn with auxiliary power supply 24V DC

(1) The minimum trip value is 1 s, regardless of the type of curve set (self-protection)

(2) These tolerances are valid in the following conditions:

- self-supplied trip unit at full power and/or auxiliary power supply (without start-up)
- two- or three-phase power supply
- trip time set ≥ 100 ms

(3) Non intervention time

(4) In accordance with IEC 60255-3

$$(5) t = \frac{(3^\alpha - 1)}{(I/I_1)^\alpha - 1} \cdot t_1$$

(6) The minimum trip threshold for the G ext protection with SRG toroid is 0,1 In

(7) If selected, Rc protection with PR122/LSIG + PR120/V and special rating plug, can replace G protection.

The following tolerance values apply in all cases not covered by the above:

Trip threshold	Trip time
S ± 10%	± 20%
G ± 15%	± 20%

4

Additional Protection functions and setting values - PR122 with PR120/V

Function	Trip threshold	Threshold steps	Trip Time	Time Step	Poss. excl.	Relation t=f(I)
UV Undervoltage protection Tolerance ⁽¹⁾	$I8 = 0.5 \dots 0.95 \times U_n$ $\pm 5\%$	$0.01 \times U_n$	With current $U < U8$ $t8 = 0.1 \text{ s} \dots 5 \text{ s}$ The better of the two figures: $\pm 20\%$ or $\pm 100 \text{ ms}$	0.1 s	■	t=k
OV Overvoltage protection Tolerance ⁽¹⁾	$I10 = 1.05 \dots 1.2 \times U_n$ $\pm 5\%$	$0.01 \times U_n$	With current $U > U10$ $t10 = 0.1 \text{ s} \dots 5 \text{ s}$ The better of the two figures: $\pm 20\%$ or $\pm 100 \text{ ms}$	0.1 s	■	t=k
RV Residual voltage protection Tolerance ⁽¹⁾	$I10 = 0.1 \dots 0.4 \times U_n$ $\pm 5\%$	$0.05 \times U_n$	With current $U_0 > U10$ $t10 = 0.5 \text{ s} \dots 30 \text{ s}$ The better of the two figures: $\pm 10\%$ or $\pm 100 \text{ ms}$	0.5 s	■	t=k
RP Phase reverse protection Tolerance ⁽¹⁾	$I11 = 0.2 \dots 0.3 \times U_n$ $\pm 5\%$	$0.02 \times U_n$	With current $U > U11$ $t11 = 0.1 \text{ s} \dots 3 \text{ s}$ The better of the two figures: $\pm 20\%$ or $\pm 100 \text{ ms}$	0.1 s	■	t=k
UF Underfrequency protection Tolerance ⁽¹⁾	$f12 = 0.90 \dots 0.99 \times f_n$ $\pm 5\%$	$0.01 \times f_n$	With current $f < f12$ $t9 = 0.5 \text{ s} \dots 3 \text{ s}$ The better of the two figures: $\pm 10\%$ or $\pm 100 \text{ ms}$	0.1 s	■	t=k
OF Overfrequency protection Tolerance ⁽¹⁾	$f13 = 1.01 \dots 1.10 \times f_n$ $\pm 5\%$	$0.01 \times f_n$	With current $f > f13$ $t13 = 0.1 \text{ s} \dots 3 \text{ s}$ The better of the two figures: $\pm 20\%$ or $\pm 100 \text{ ms}$	0.1 s	■	t=k

(1) These tolerances are valid in the following conditions:
 - self-supplied trip unit at full power and/or auxiliary power supply (without start-up)
 - two- or three-phase power supply

Power supply

The PR122 trip unit does not normally require any external power supplies, being self-supplied from the current sensors (CS): a three-phase 70 A current is sufficient to activate the protection functions and the ammeter, whereas three-phase 160 A are required to turn the display on. Once the display is turned on, the minimum current for visualisation is $I > 5\%$ of the rating plug. The unit ensures fully self-supplied operation. When an auxiliary power supply is present, it is also possible to use the unit with the circuit-breaker either open or closed with very low current flowing through.

It is also possible to use an auxiliary power supply provided by the PR030/B portable battery unit (always supplied), which allows the protection functions to be set when the trip unit is not self-supplied.

PR122/P stores and shows all the information needed after a trip (protection tripped, trip current, time, date). No auxiliary supply is required for this functionality.

	PR122/P	PR120/D-M	PR120/K	PR120/D-BT
Maximum ripple	5%			
Rated power @ 24V	-3 W	+1 W	+1 W	+1 W

(*) PR120/V can give power supply to the trip unit when at least one line voltage is equal or higher to 85V RMS.



Protection trip units and trip curves

PR122/P

Functions L-I

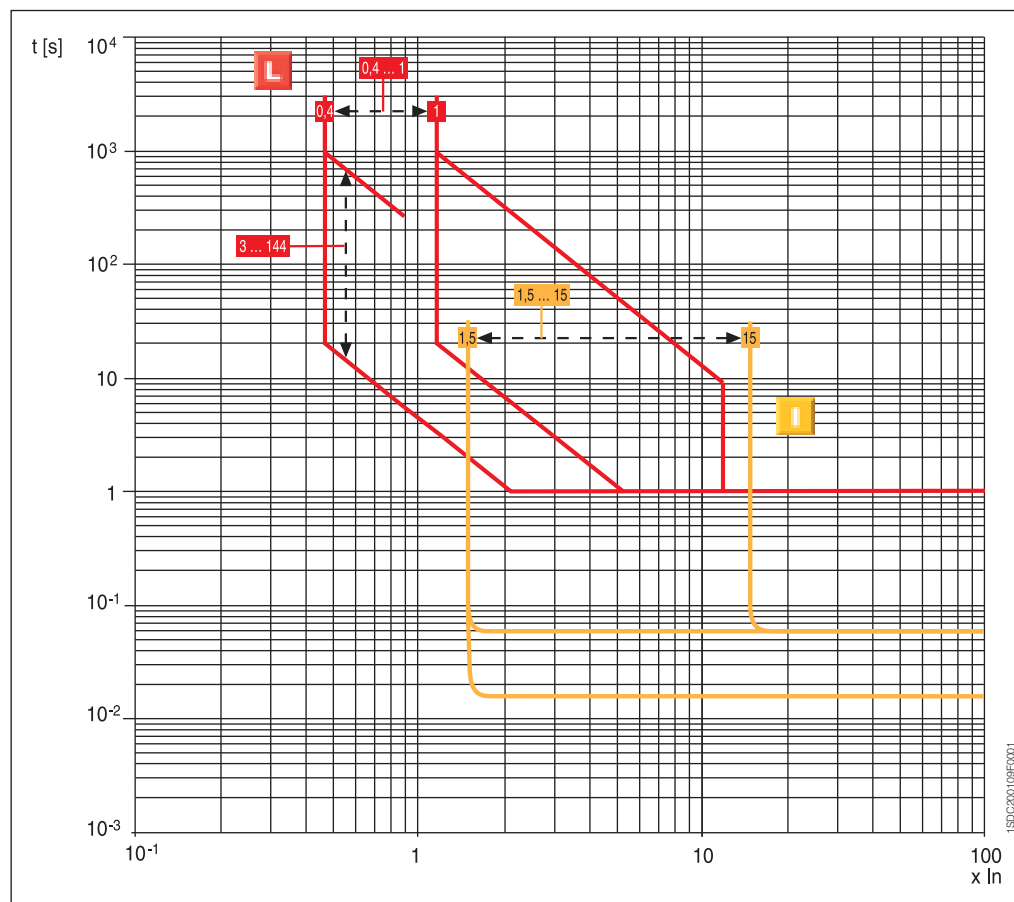

4

Functions L-S-I

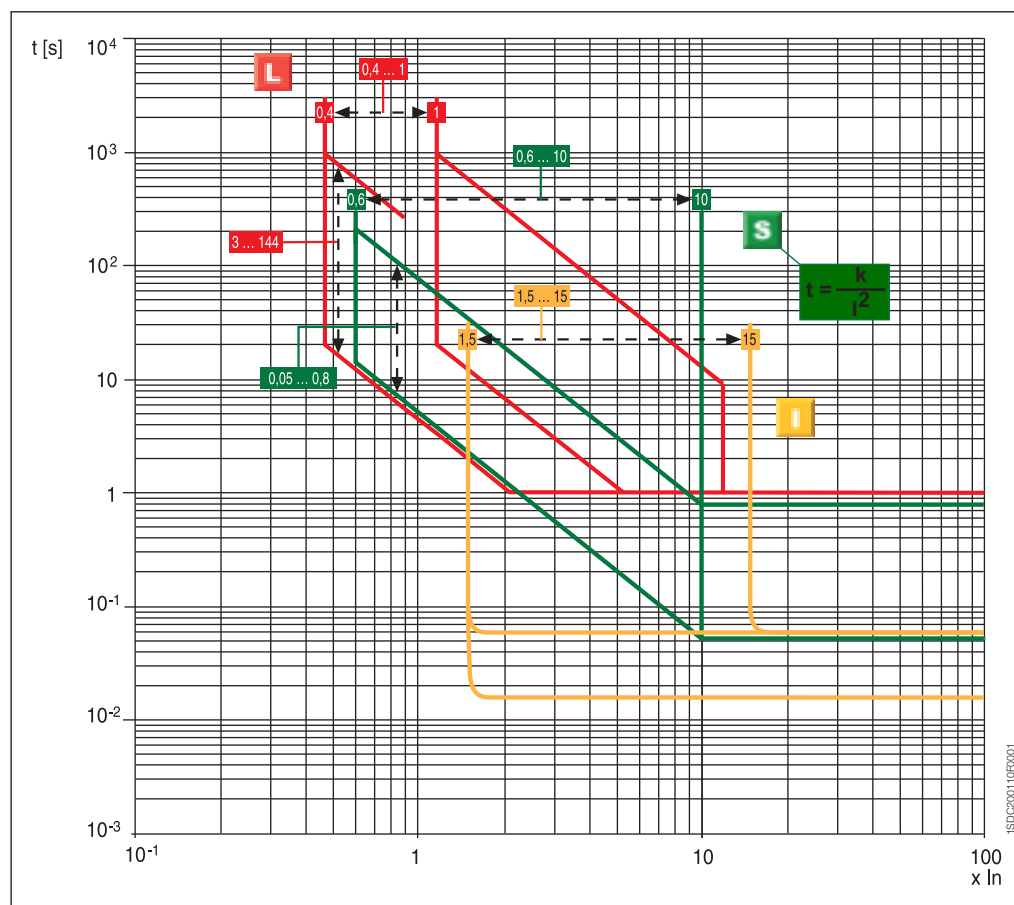

Threshold and trip times tolerances page 4/16

Functions L-S-I

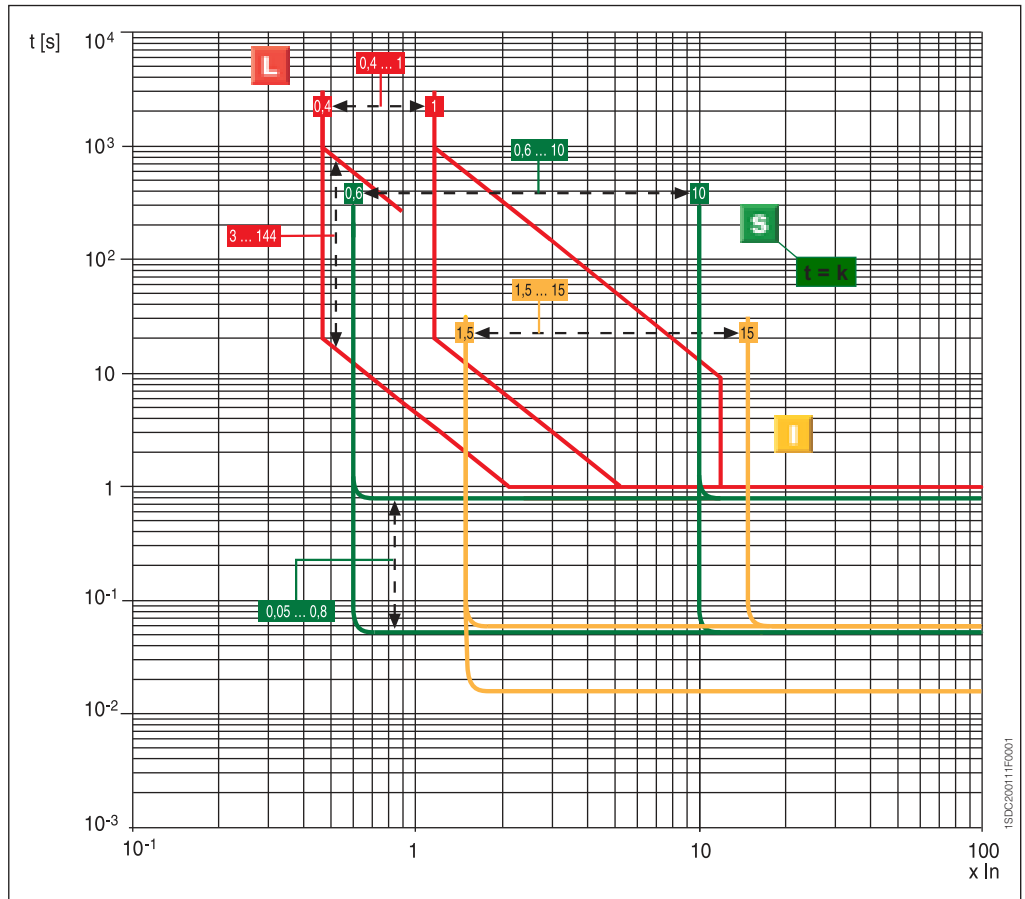

Function L

According to IEC 60255-3

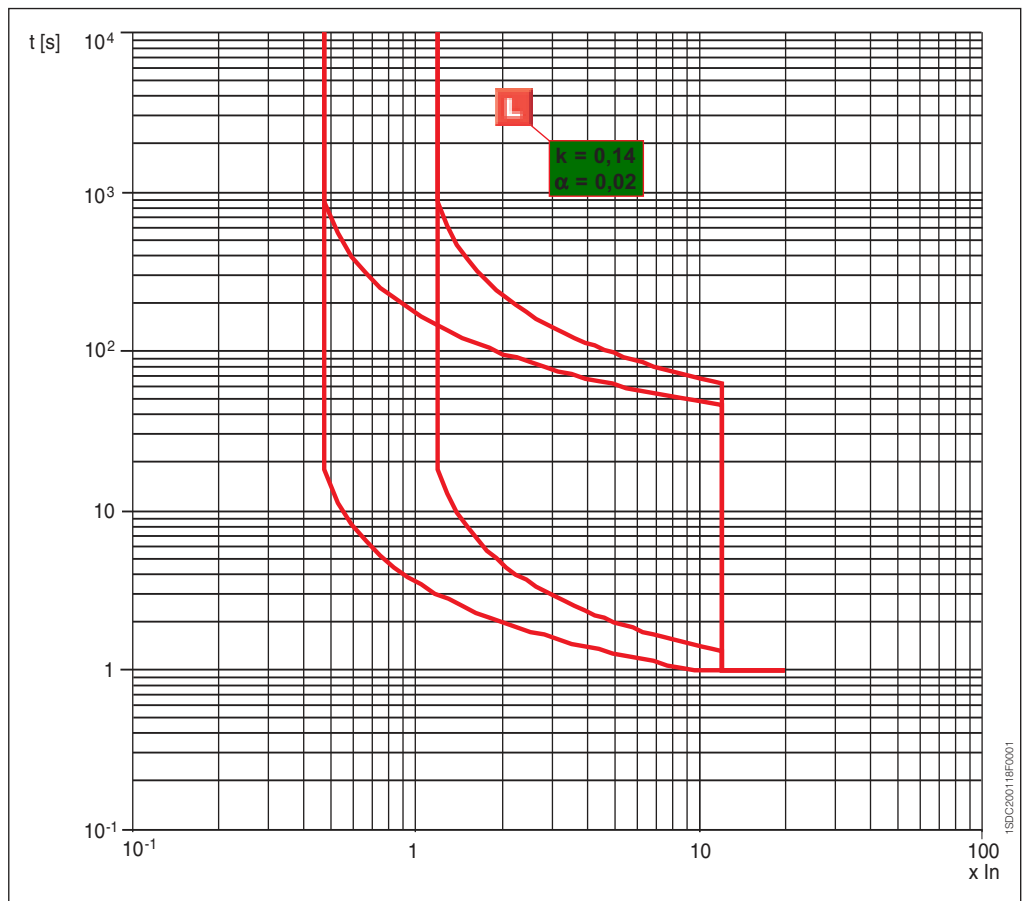

Threshold and trip times tolerances page 4/16



Protection trip units and trip curves

PR122/P

Function L

According to IEC 60255-3

4

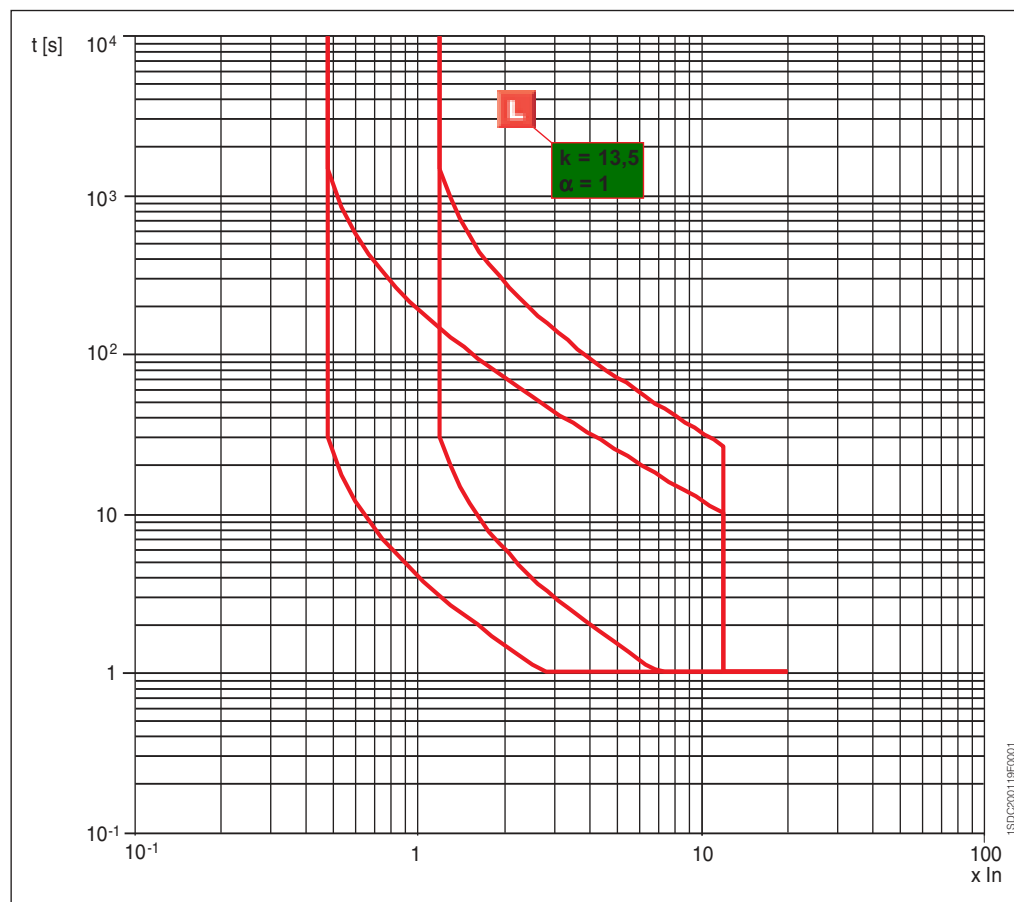

Function L

According to IEC 60255-3

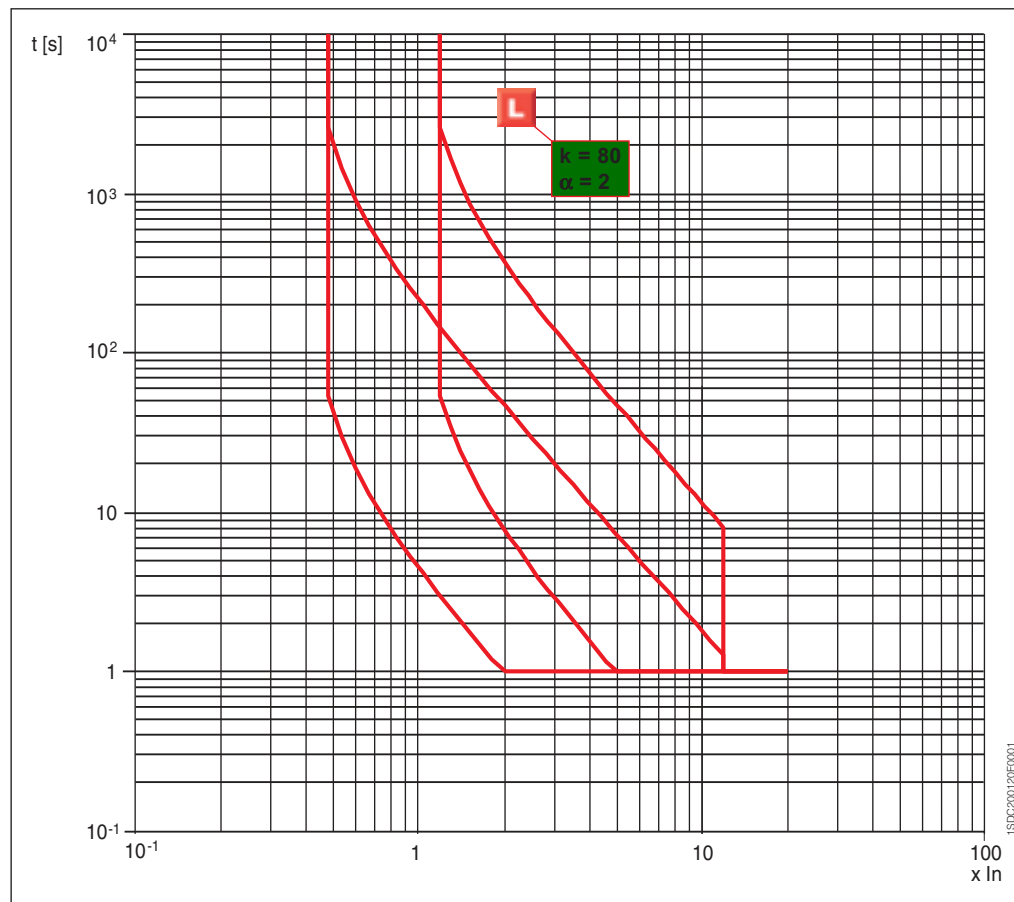

Threshold and trip times tolerances page 4/16

Function G

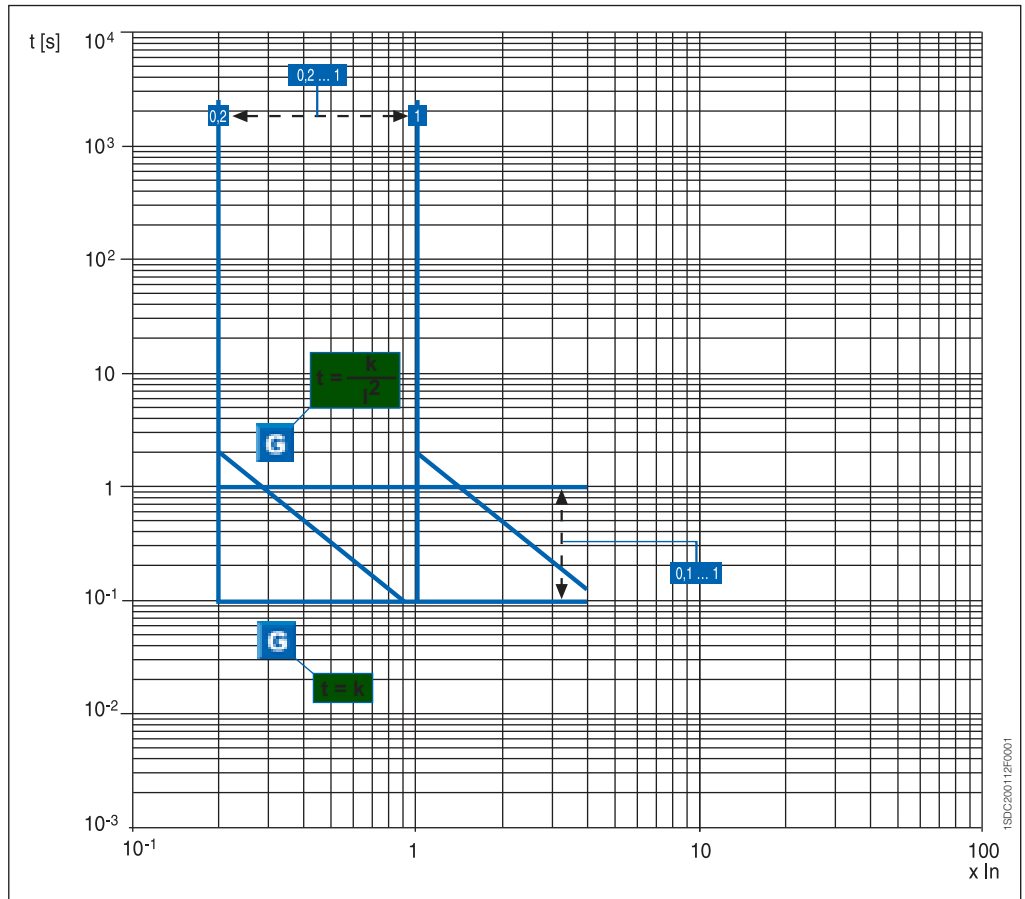

Function U

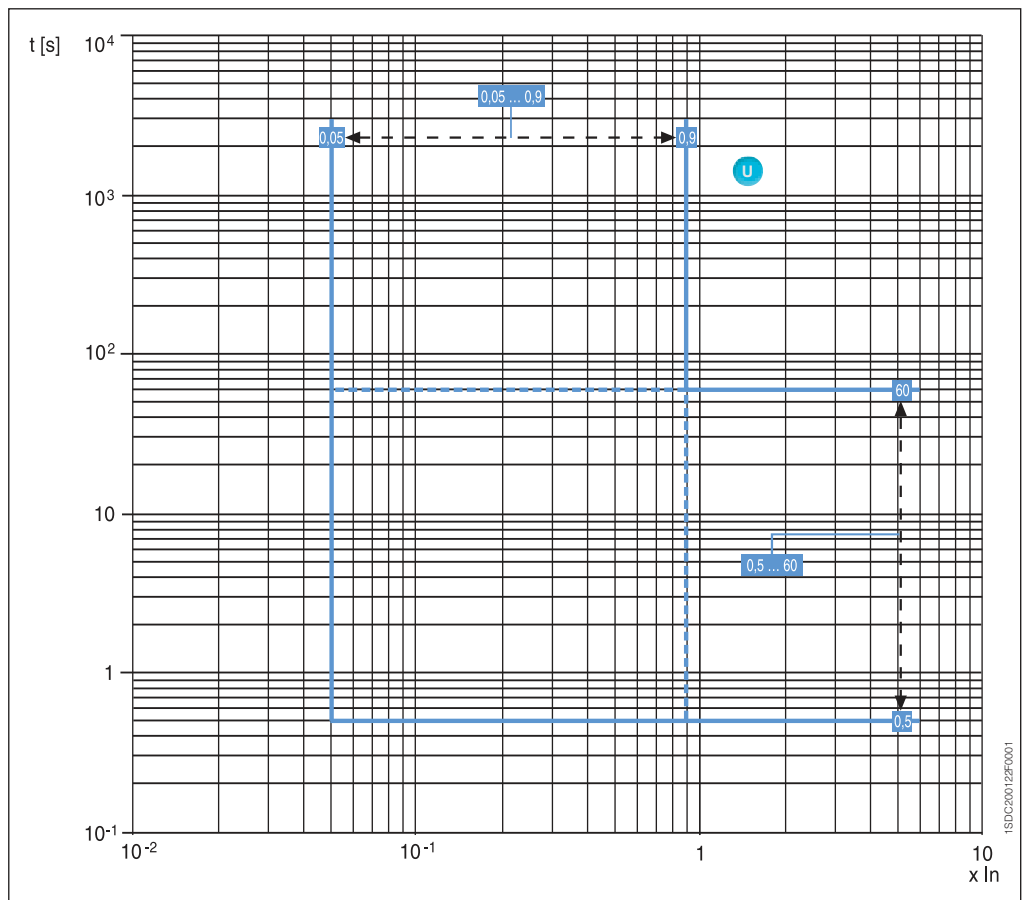

Threshold and trip times tolerances page 4/16



Protection trip units and trip curves

PR122/P

Function UV

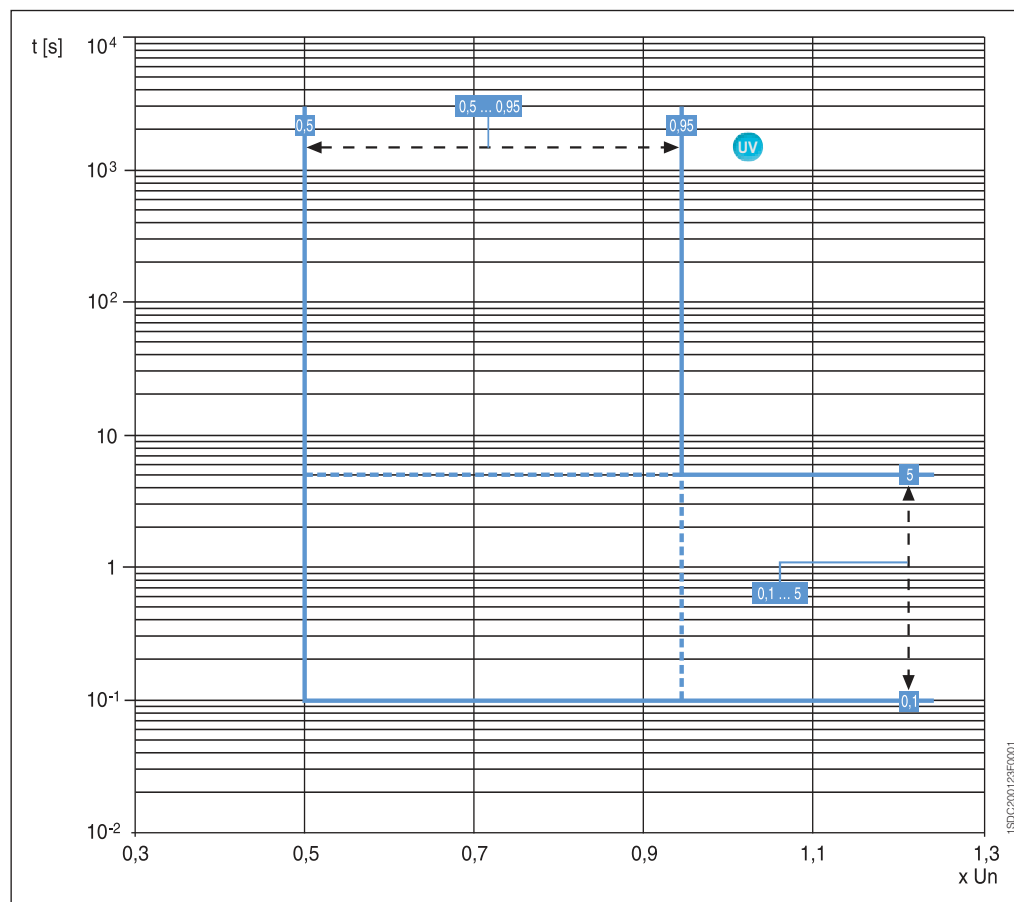

4

Function OV

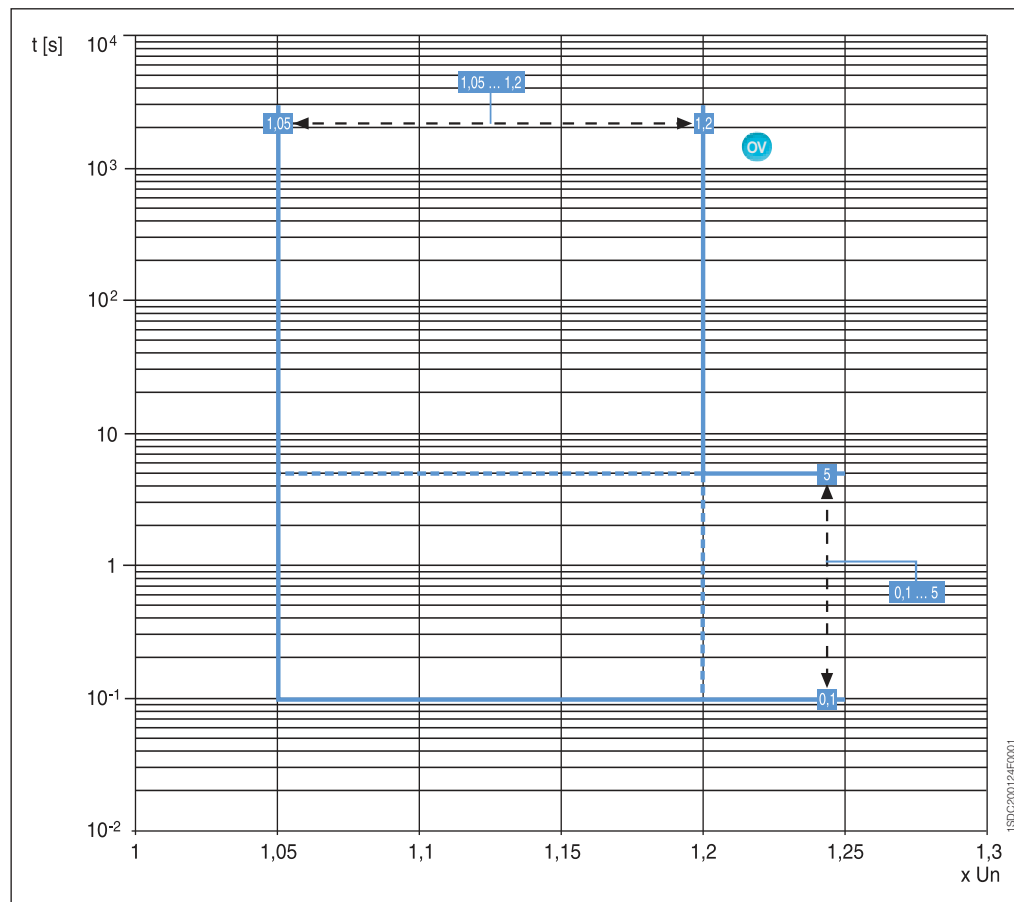

Threshold and trip times tolerances page 4/16

Function RV

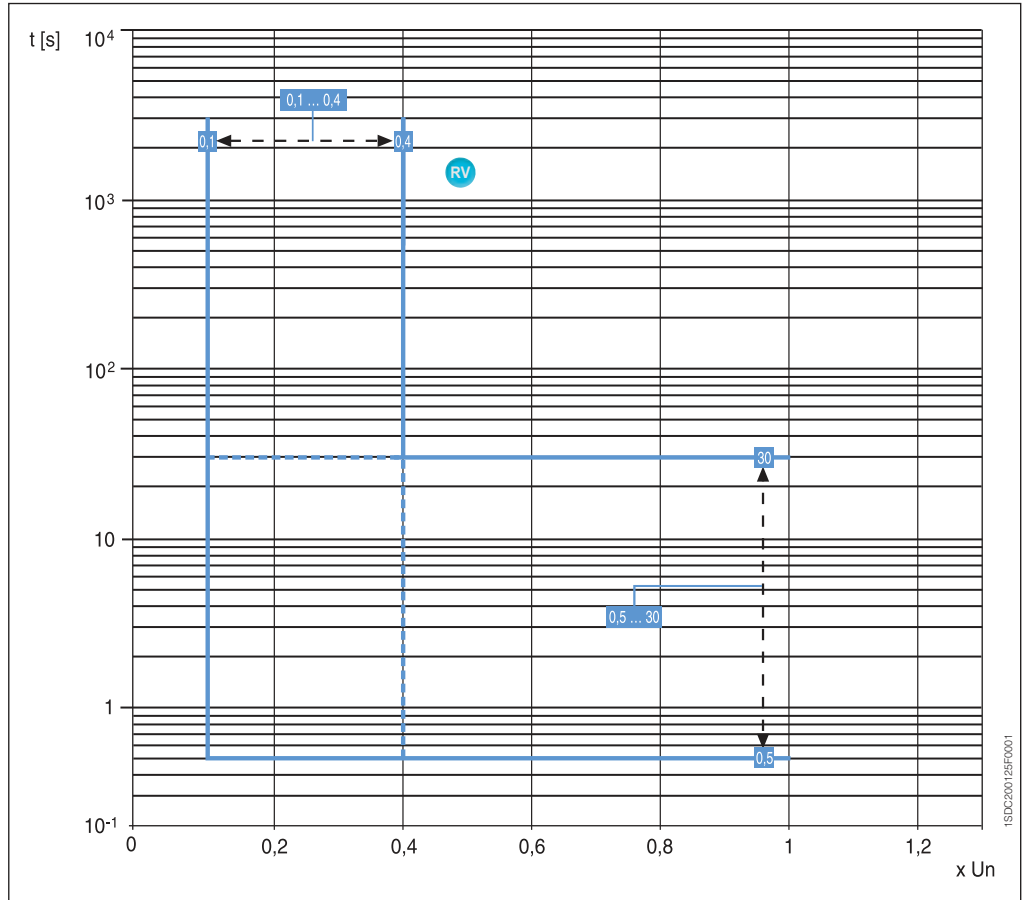

Function RP

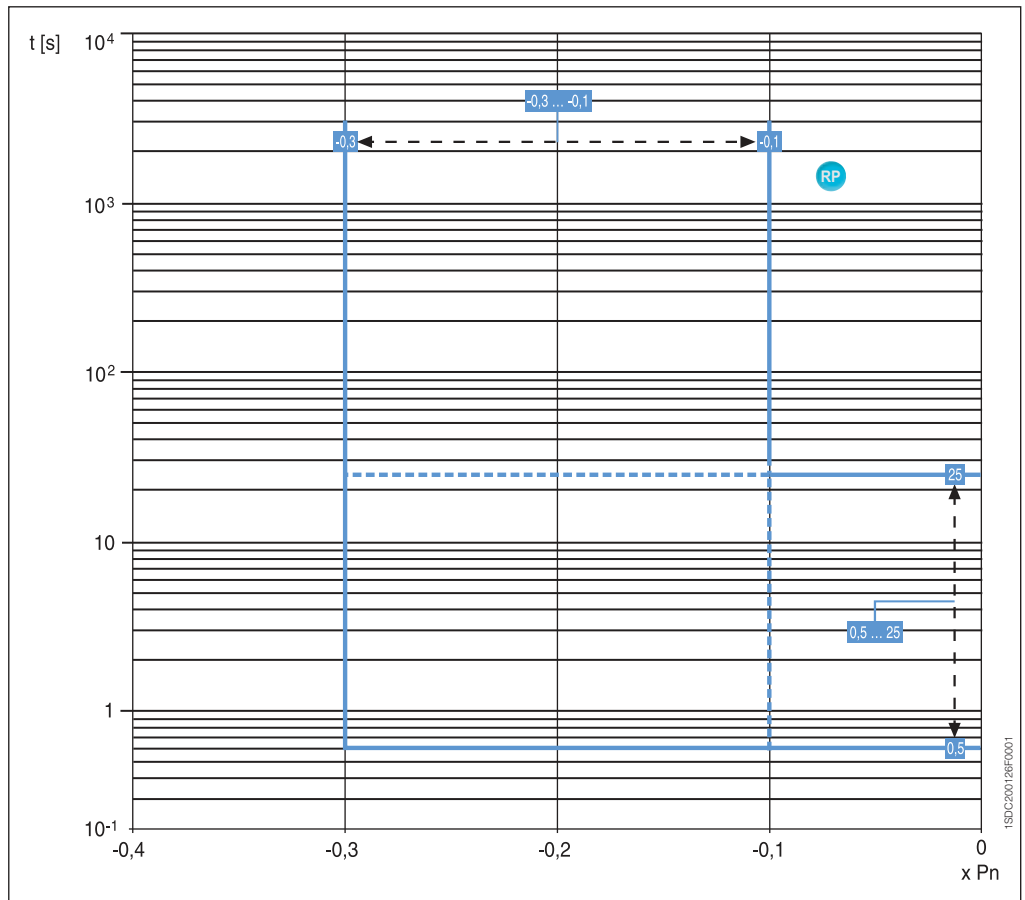

Threshold and trip times
tolerances page 4/16



Protection trip units and trip curves

PR123/P

Characteristics

The PR123 protection trip unit completes the range of trip units available for the Emax family of circuit-breakers.

It is a high-performance and extraordinarily versatile trip unit, capable of offering a complete set of functions for protection, measurement, signalling, data storage and control of the circuit-breaker, and it represents the benchmark in low voltage protection units for circuit-breakers.

The front interface of the unit, common to PR122/P, is extremely simple thanks to the aid of the liquid crystal graphics display. It can show diagrams, bar graphs, measurements and sine curves for the various electrical values.

PR123 integrates all the features offered by PR122/P plus a series of evolve functionalities. As well as PR122 it can be integrated with the additional features provided by internal modules and external accessories.

4



Caption

- 1 LED Warning indicator
- 2 Alarm LED
- 3 Rear-lit graphic display
- 4 Cursor UP button
- 5 Cursor DOWN button
- 6 Test connector for connecting or testing the trip unit by means of an external device (PR030/B battery unit, BT030 wireless communication unit and SACE PR010/T unit)
- 7 ENTER button to confirm data or change pages
- 8 Button to exit submenus or cancel operations (ESC)
- 9 Rating plug
- 10 Serial number of protection trip unit
- 11 Power LED
- 12 Voltage uptake switch-disconnector

Protection functions

The PR123 trip unit offers the following protection functions:

- overload (L) ⁽¹⁾,
- selective short-circuit (S),
- instantaneous short-circuit (I),
- earth fault with adjustable delay (G) ⁽²⁾,
- directional short-circuit with adjustable delay (D),
- phase unbalance (U),
- protection against overtemperature (OT),
- load control (K),
- undervoltage (UV),
- overvoltage (OV),
- residual voltage (RV),
- reverse power (RP),
- underfrequency (UF),
- overfrequency (OF),
- phase sequence (alarm only).

Notes:

(1) In accordance also with IEC 60255-3 Standard.

(2) The current values above which G is disabled are indicated in the installation manual.

In addition to PR122/P features, the following improvements are available:

Double selective short-circuit protection S

In addition to the standard S protection, PR123/P makes contemporarily available a second time-constant S protection (excludible) that allows two thresholds to be set independently achieving an accurate selectivity even under highly critical conditions.

Double earth fault protection G

While in PR122/P the user must choose among the implementation of G protection through internal current sensors (calculating the vectorial sum of currents) or external toroid (direct earth fault current measuring), PR123/P offers the exclusive feature of the contemporaneous management of both the configuration, by means of two independent earth fault protection curves. The main application of this characteristic is simultaneous activation of restricted and unrestricted earth fault protection. See chapter 6 for details.

Directional short-circuit protection with adjustable delay D

The protection works in a similar way to the fixed-time protection “S”, with the added ability to recognize the direction of the phases current during the fault period.

The current direction makes it possible to determine whether the fault is on the supply or load side of the circuit-breaker. Particularly in ring distribution systems, this makes it possible to identify and disconnect the distribution segment where the fault has occurred, whilst keeping the rest of the installation running. If multiple PR122 or PR123 trip units are used, this protection can be associated with zone selectivity.

Residual current protection Rc

With PR123/P is possible to have the residual current protection only adding the external toroid (1SDA063869).



Protection trip units and trip curves

PR123/P

Notes:

The directional short-circuit protection can be disabled for an adjustable set time ($t = k$), and can either be self-supplied or use the auxiliary power supply. Directional protection is not available on 400A rating.

Dual setting of protections

PR123/P can store an alternative set of all the protection parameters. This second set (set B) can replace, when needed, the default set (set A) by means of an external command. The command can be given typically when network configuration is modified, like when a parallel of incoming lines is closed or when an emergency source is present in the system, changing load capability and short-circuit levels.

The set B can be activated by:

- digital input provided with PR120/K module. For example It can be connected to an auxiliary contact of a bus-tie
- communication network, through PR120/D-M (i.e. when the changeover is scheduled);
- directly from user interface of PR123/P
- an adjustable time interval after closing of the circuit-breaker.

Zone selectivity function

The zone selectivity function allows the fault area to be insulated by segregating the system very rapidly only at the level closest to the fault, whilst leaving the rest of the installation running.

This is done by connecting the trip units together: the trip unit nearest the fault is tripped instantly, sending a block signal to the other trip units affected by the same fault

The zone selectivity function can be enabled if the fixed-time curve has been selected and an auxiliary power supply is present.

Zone selectivity can be applied with protections S and G or, alternatively, with protection D.

Measurement functions

The PR123 trip unit provides a complete set of measurements:

- Currents: three phases (L1, L2, L3), neutral (Ne) and earth fault
- Voltage: phase-phase, phase-neutral and residual voltage
- Power: active, reactive and apparent
- Power factor
- Frequency and peak factor, $\left(\frac{I_p}{I_{rms}}\right)$
- Energy: active, reactive, apparent, counter
- Harmonics calculation: up to the 40th harmonic (waveform and module of the harmonics displayed); up to the 35th for frequency $f = 60\text{Hz}$
- Maintenance: number of operations, percentage of contact wear, opening data storage
- $\cos\phi$: phase sequence (only alarm).

The PR123 unit is able to provide the pattern of measurements for some values over an adjustable period of time P, such as: mean active power, maximum active power, maximum current, maximum voltage and minimum voltage. The last 24 P periods (adjustable from 5 to 120 min.) are stored in a non-volatile memory and displayed in a bar graph.

Other Functions

PR123/P integrates all the features (in terms of protection, measurement, signaling and communication) described for PR122/P equipped with PR120/V. With PR123/P-LSIG, when the special rating plug for residual current protection and the external toroid are activate, the earth fault protection, if selected, can replace Gext protection, while G protection keep on being active.

Protection functions and setting values - PR123

Function	Trip threshold	Threshold steps	Trip Time	Time Step	Can be excluded	Relation t=f(I)	Thermal memory	Zone selectivity
L Overload protection Tolerance ⁽²⁾	I1= 0.4...1 x In Release between 1.05 and 1.2 x I1	0.01 x In	With current If = 3xI1 t1= 3 s...144 s ± 10% If ≤ 6 x In ± 20% If > 6 x In	3 s ⁽¹⁾	–	t=k/I ²	■	–
Tolerance	I1= 0.4...1 x In Release between 1.05 ... 1.2 x I1	0.01 x In	With current I=3xI1 ⁽⁶⁾ ; t1=3s...144s ± 20% If > 5 x I1 ± 30% 2xI1 ≤ If ≤ 5 x I1	3 s	–	t=k(α) ⁽⁵⁾ α = 0.2-1-2	–	–
S Selective short-circuit protection Tolerance ⁽²⁾	I2= 0.6...10 x In ± 7% If ≤ 6 x In ± 10% If > 6 x In	0.1 x In	With current If > I2 t2= 0.05 s...0.8 s t2sel= 0.04 s...0.2 s The better of the two figures: ± 10% or ± 40 ms	0.01 s 0.01 s	■	t=k	■	■
Tolerance ⁽²⁾	I2= 0.6...10 x In ± 7% If ≤ 6 x In ± 10% If > 6 x In	0.1 x In	With current I=10xIn; t2=0.05s...0.8s ± 15% If ≤ 6 x In ± 20% If > 6 x In	0.01 s	■	t=k/I ²	■	–
S+ Selective short-circuit protection Tolerance ⁽²⁾	I2= 0.6...10 x In ± 7% If ≤ 6 x In ± 10% If > 6 x In	0.1 x In	With current If > I2 t2= 0.05 s...0.8 s The better of the two figures: ± 10% or ± 40 ms	0.01 s	■	t=k	–	■
I Instantaneous short-circuit protection Tolerance ⁽²⁾	I3= 1.5...15 x In ± 10%	0.1 x In	Instantaneous ≥ 30 ms	–	■	t=k	–	–
G Earth fault protection Tolerance ⁽²⁾	I4 ⁽⁶⁾ = 0.1*...1 x In ± 7%	0.02 x In	With current If > I4 t4= 0.1 s...1 s t4sel= 0.04 s...0.2 s The better of the two figures: ± 10% or ± 40 ms	0.05 s 0,01 s	■	t=k	–	■
Tolerance ⁽²⁾	I4= 0.1*...1 x In ± 7%	0.02 x In	t4= 0.1 s...1 s (with I=4xI4) ± 15%	0.05 s	■	t=k/I ²	–	–
Rc Residual Current protection Tolerance ⁽²⁾	IΔ= 3-5-7-10-20-30 A ± 10%	–	IΔ= 0.05-0.1-0.2-0.3-0.4-0.5-0.8 s ⁽⁷⁾	–	■	t=k	–	–
D Directional short-circuit protection Tolerance ⁽²⁾	I7= 0.6...10 x In ± 10%	0.1 x In	With current If > I7 t7= 0.20 s...0.8 s The better of the two figures: ± 10% or ± 40 ms	0.01 s	■	t=k	–	■
U Phase unbalance protection Tolerance ⁽²⁾	I8= 5%...30% ± 10%	5%	I8= 0.5 s...30 s The better of the two figures: ± 20% or ± 100 ms	0.5 s	■	t=k	–	–
OT Protection against overtemperature	cannot be set	–	Instantaneous	–	–	temp=k	–	–
UV Undervoltage protection Tolerance ⁽²⁾	I9= 0.5...0.95 x Un ± 5%	0.01 x In	With current U > U9; t9= 0.1s...5s The better of the two figures: ± 20% or ± 40 ms	0.1 s	■	t=k	–	–
OV Overvoltage protection Tolerance ⁽²⁾	I9= 1.05...1.2 x Un ± 5%	0.01 x In	With current U > U9; t9= 0.1s...5s The better of the two figures: ± 20% or ± 40 ms	0.1 s	■	t=k	–	–
RV Residual voltage protection Tolerance ⁽²⁾	I10= 0.1...0.4 x Un ± 5%	0.05 Un	With current U > U10; t10= 0.5s...30s The better of the two figures: ± 10% or ± 100 ms	0.5 s	■	t=k	–	–
RP Reverse power protection Tolerance ⁽²⁾	P11= -0.3...-0.1 x Pn ± 10%	0.02 Pn	With current P < P11 t11= 0.5 s...25 s The better of the two figures: ± 10% or ± 100 ms	0.1 s	■	t=k	–	–
UF Underfrequency protection Tolerance ⁽²⁾	f12 = 0.90...0.99 x fn ± 5%	0.01 fn	With current f > f12; t12= 0.5s...3s The better of the two figures: ± 10% or ± 100 ms	0.1 s	■	t=k	–	–
OF Overfrequency protection Tolerance ⁽²⁾	f13 = 1.01...1.10 x fn ± 5%	0.01 fn	With current f > f13; t13= 0.5s...3s The better of the two figures: ± 10% or ± 100 ms	0.1 s	■	t=k	–	–

If = fault current

* G=0.1xIn with auxiliary power supply 24V DC

(1) The minimum trip value is 1 s, regardless of the type of curve set (self-protection)

(2) These tolerances hold in the following conditions:

- self-powered relay at full power and/or auxiliary power supply (without start-up)
- two- or three-phase power supply
- trip time set ≥ 100 ms

(3) Non intervention time

(4) In accordance with IEC 60255-3

(5) $t = \frac{(3^\alpha - 1)}{(I/I1)^\alpha - 1} \cdot t1(3xI1)$

(6) The minimum trip threshold for the G ext protection with SRG toroid is 0,1 In

(7) If selected, Rc protection with PR123/P-LSIG and special rating plug, can replace Gext protection.

The following tolerance values apply in all cases not covered by the above:

Trip threshold	Trip time
Release between 1.05 and 1.25 x I1	± 20%
S ± 10%	± 20%
± 15%	± 30ms
G ± 15%	± 20%
IΔ=3A	± 20%



Protection trip units and trip curves

PR123/P

Power supply

The PR123 trip unit does not normally require any external power supplies, being self-supplied from the current sensors (CS): a three-phase 70 A current is sufficient to activate the protection functions and the ammeter, whereas three-phase 160 A are required to turn the display on. Once the display is turned on, the minimum current for visualisation is $I > 5\%$ of the rating plug. The unit ensures fully self-supplied operation. When an auxiliary power supply is present, it is also possible to use the unit with the circuit-breaker either open or closed with very low current flowing through.

It is also possible to use an auxiliary power supply provided by the PR030/B portable battery unit (always supplied), which allows the protection functions to be set when the trip unit is not self-supplied.

PR123/P stores and shows all the information needed after a trip (protection tripped, trip current, time, date). No auxiliary supply is required for this functionality.

	PR123/P	PR120/D-M	PR120/K	PR120/D-BT
Auxiliary power supply (galvanically insulated)	24 V DC \pm 20%	from PR122/PR123	from PR122/PR123	from PR122/PR123
Maximum ripple	5%			
Inrush current @ 24V	~10 A for 5 ms			
Rated power @ 24V	~3 W	+1 W	+1 W	+1 W

PR120/V can give power supply to the trip unit when at least one line voltage is equal or higher to 85V.

Functions L-S-I

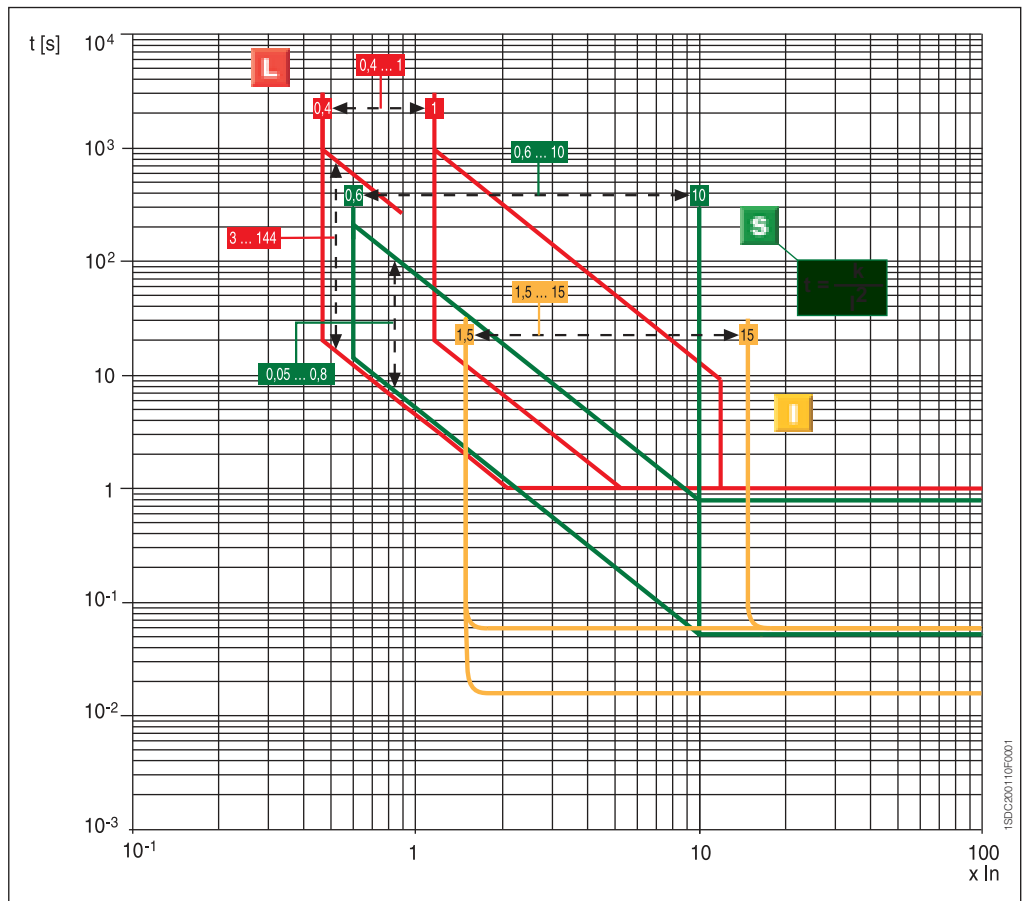

1SDC200110F0001

Functions L-S-I

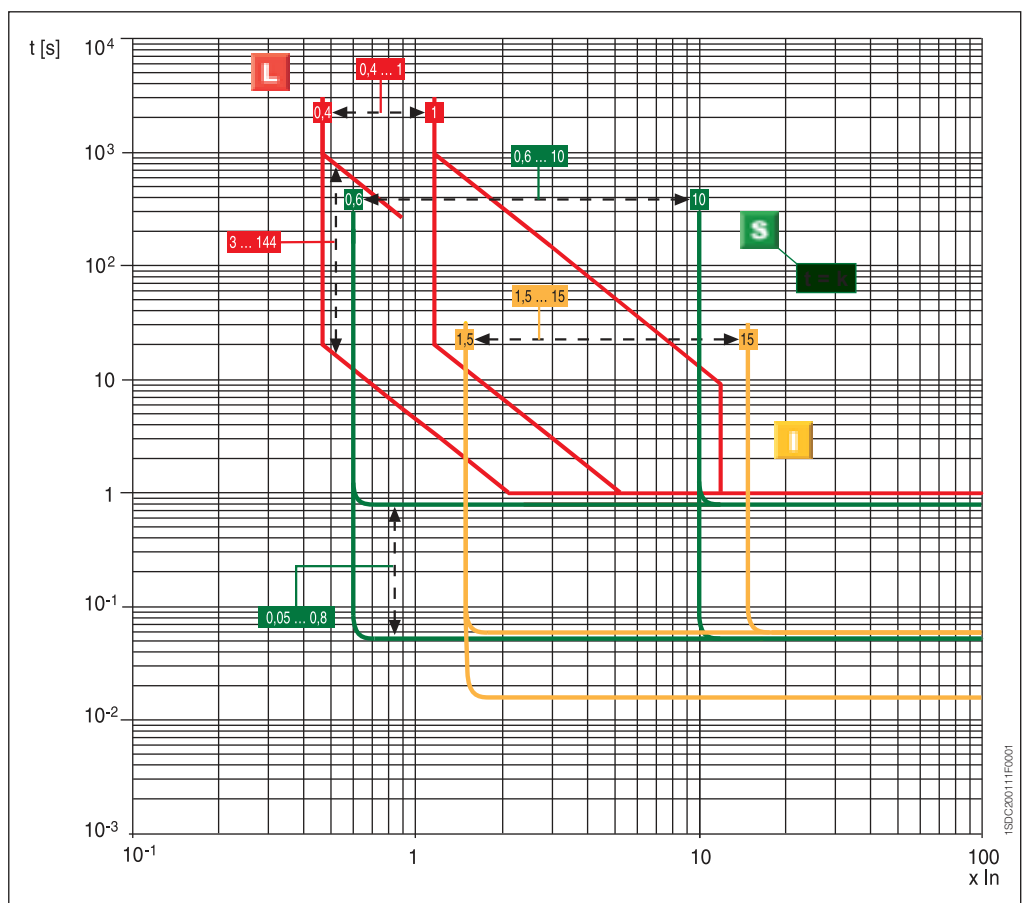

1SDC200111F0001

Threshold and trip times tolerances page 4/27



Protection trip units and trip curves

PR123/P

Function L

According to IEC 60225-3

4

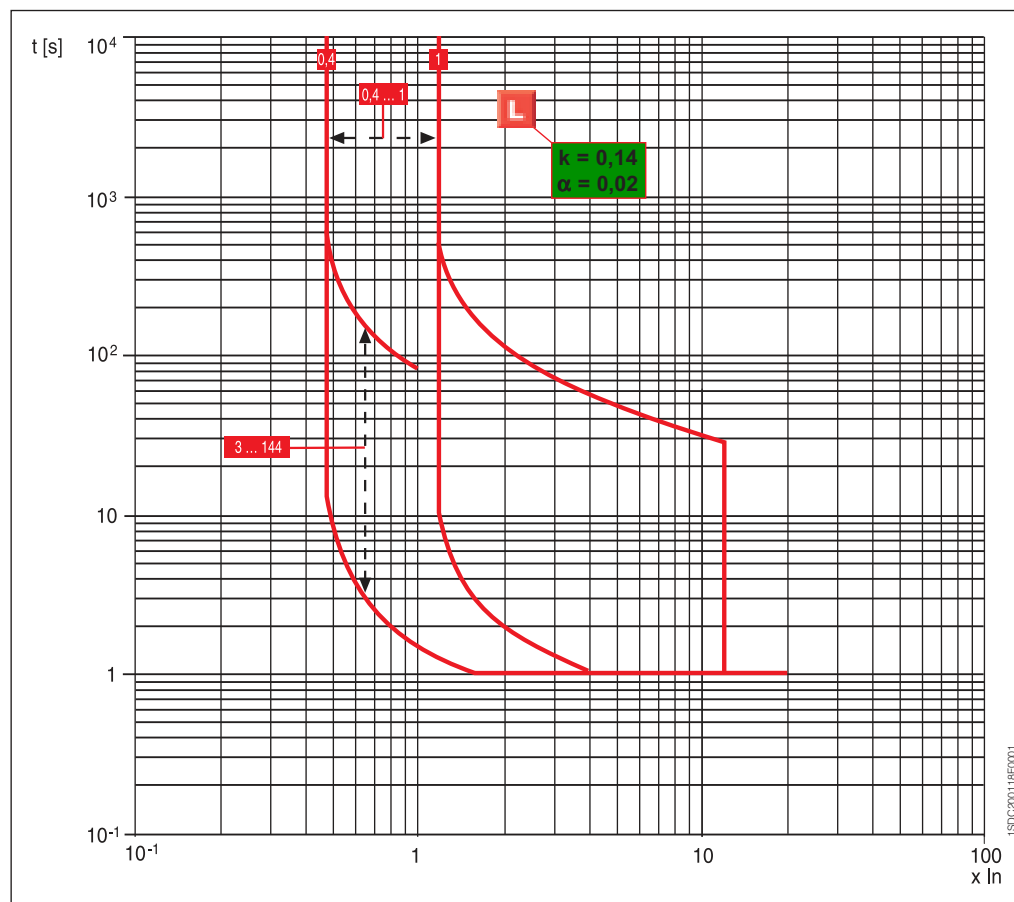

Function L

According to IEC 60225-3

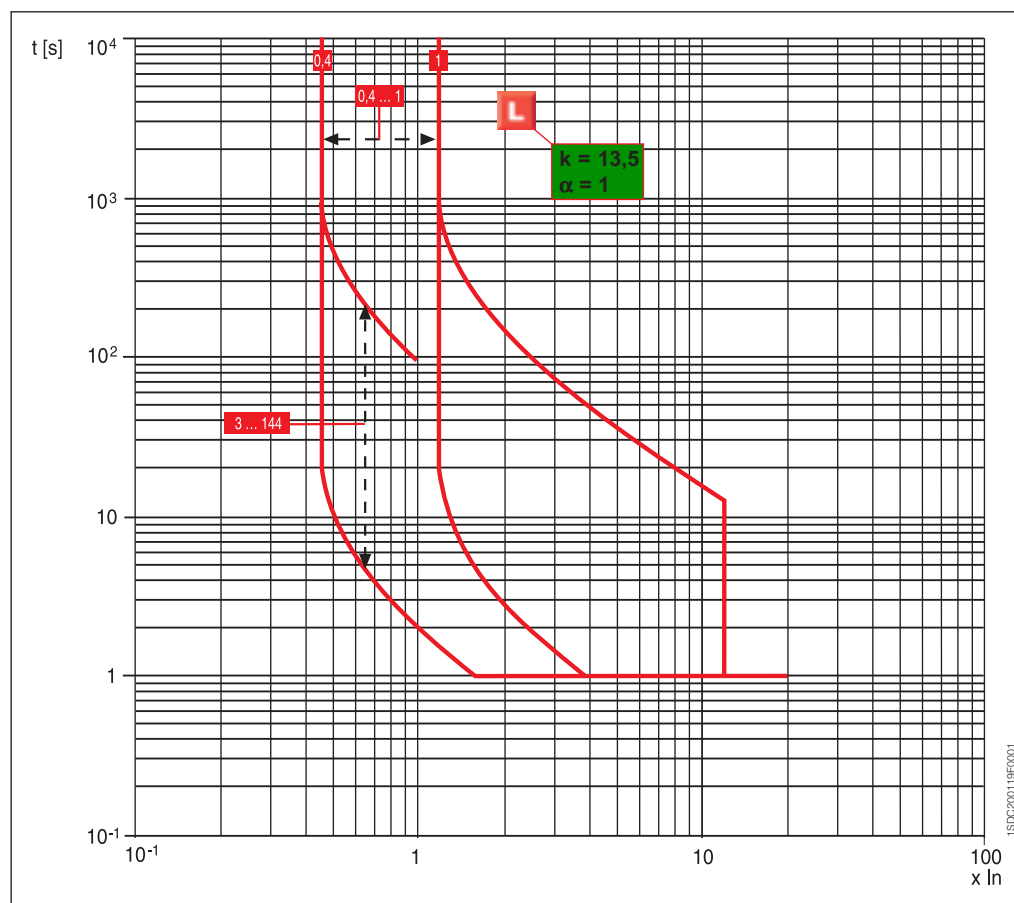

Threshold and trip times tolerances page 4/27

Function L

According to IEC 60225-3

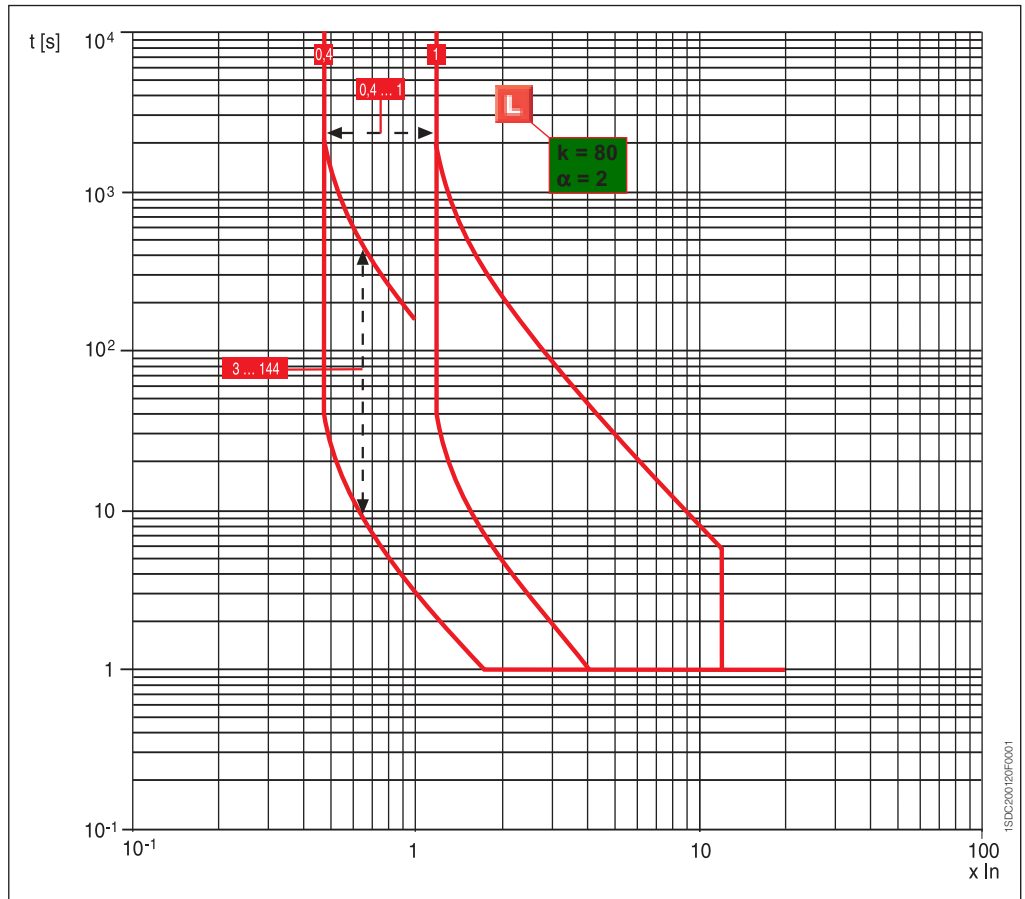

Function G

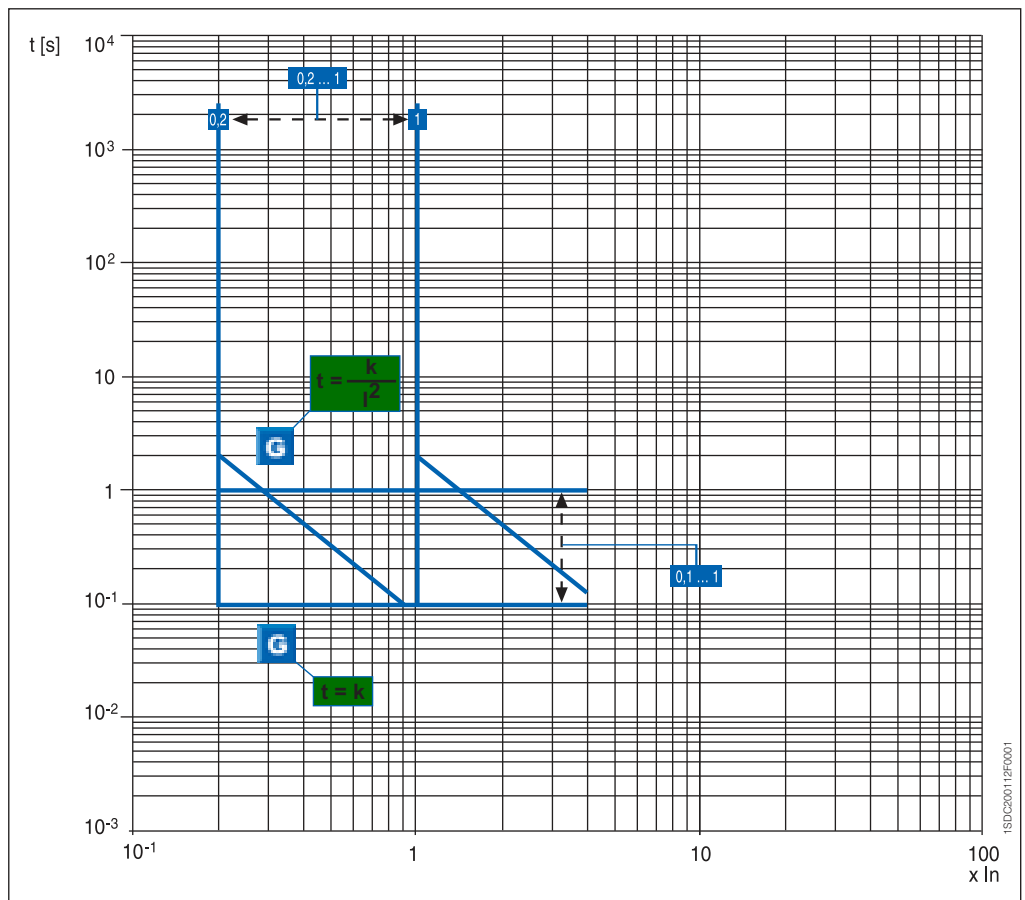

Threshold and trip times tolerances page 4/27



Protection trip units and trip curves

PR123/P

Function D

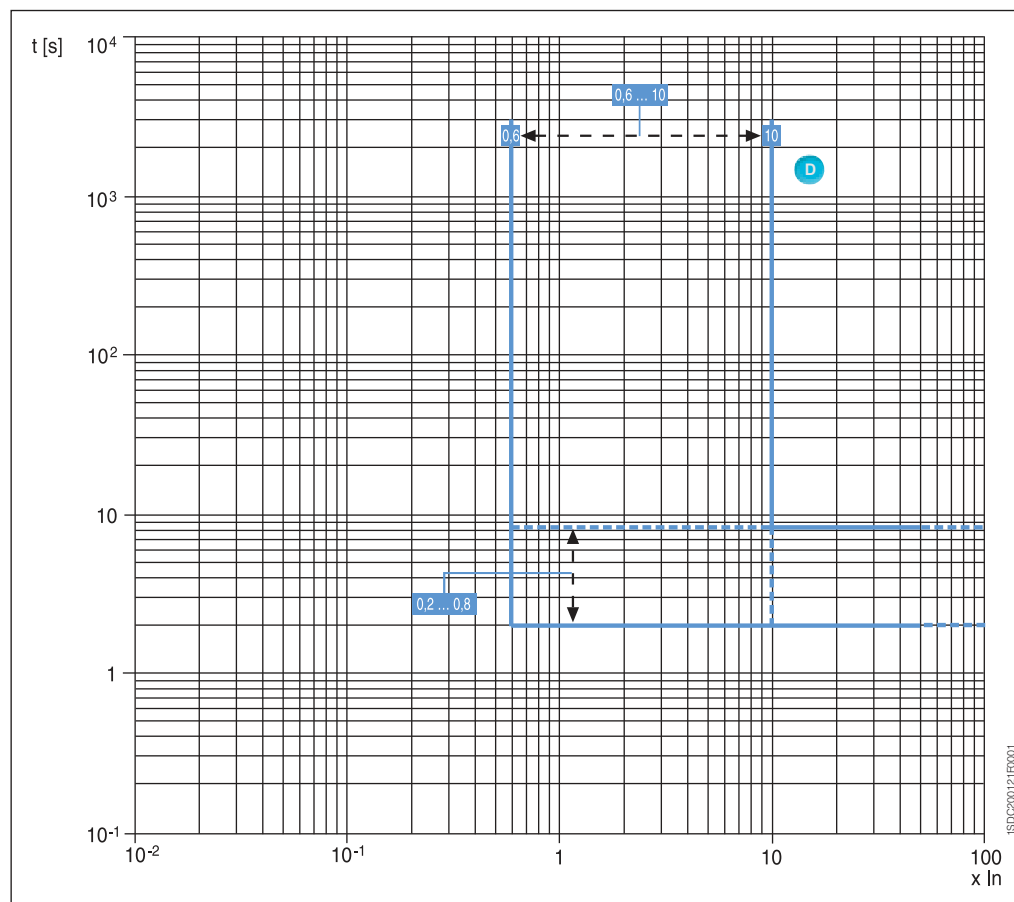

1SDC200121F0001

4

Function U

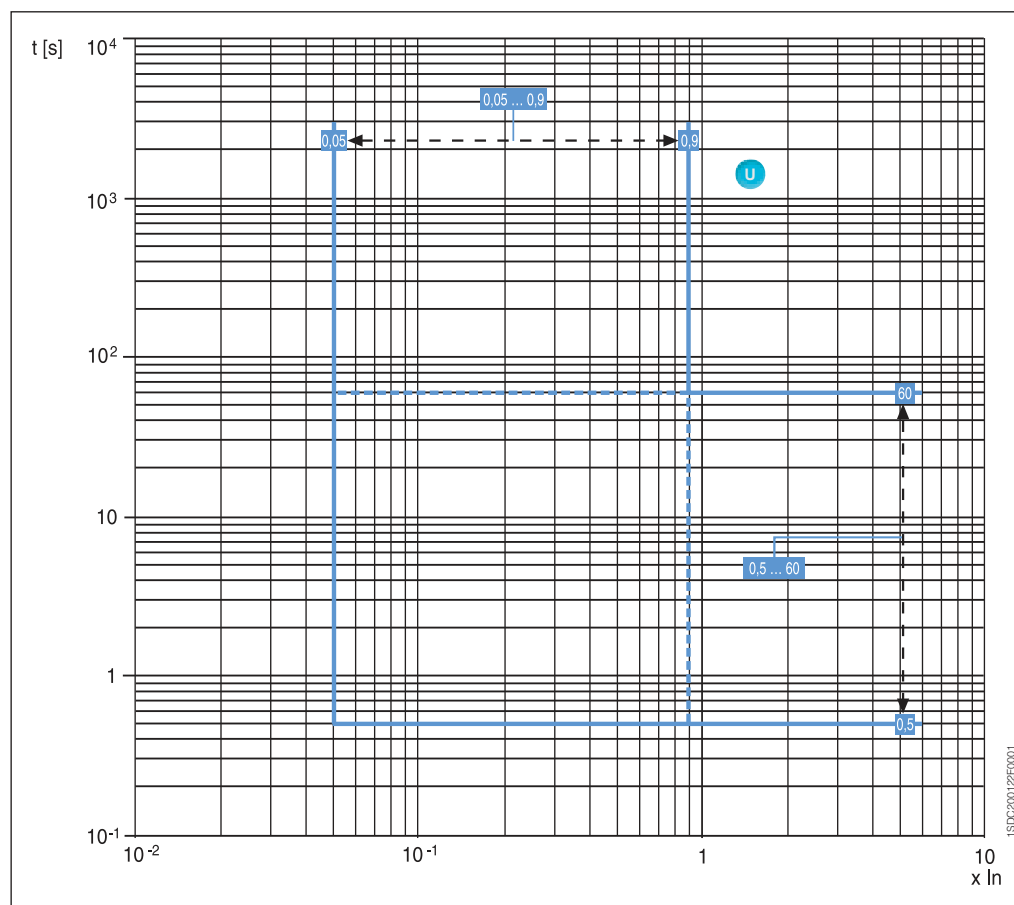

1SDC200122F0001

Threshold and trip times tolerances page 4/27

Function UV

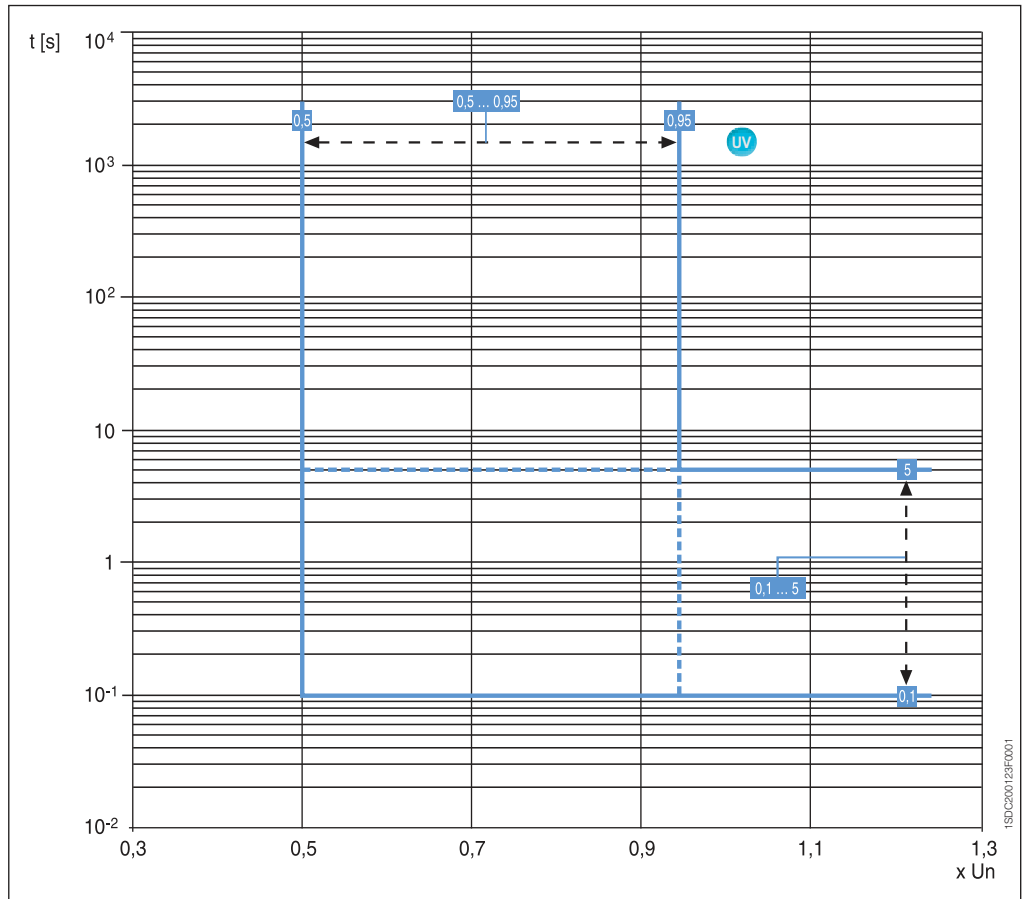

Function OV

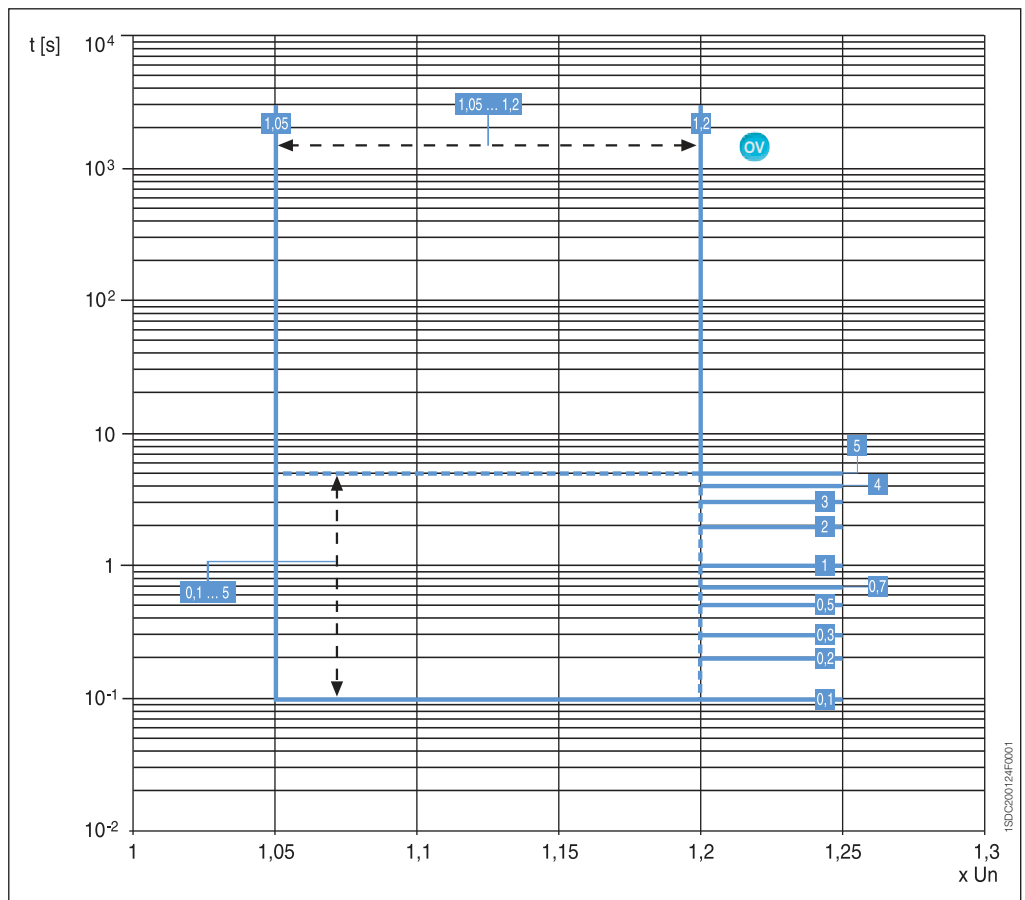

Threshold and trip times tolerances page 4/27



Protection trip units and trip curves

PR123/P

Function RV

4

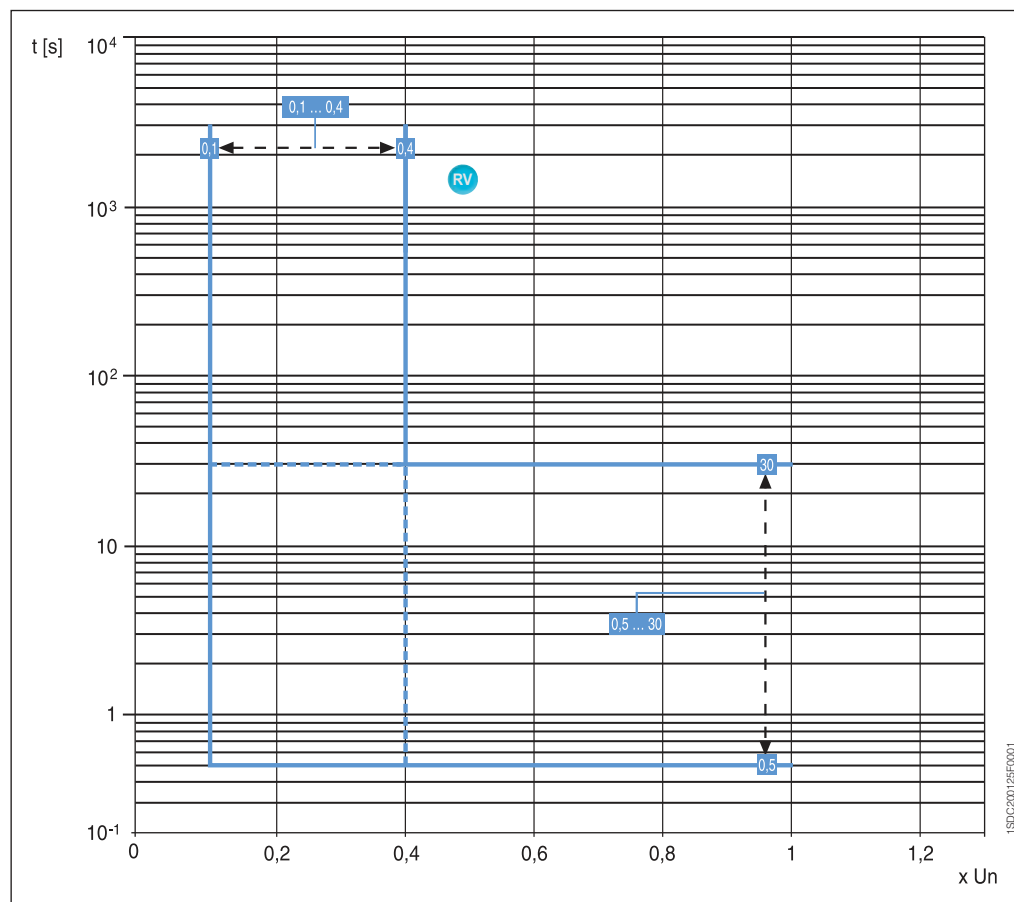

Function RP

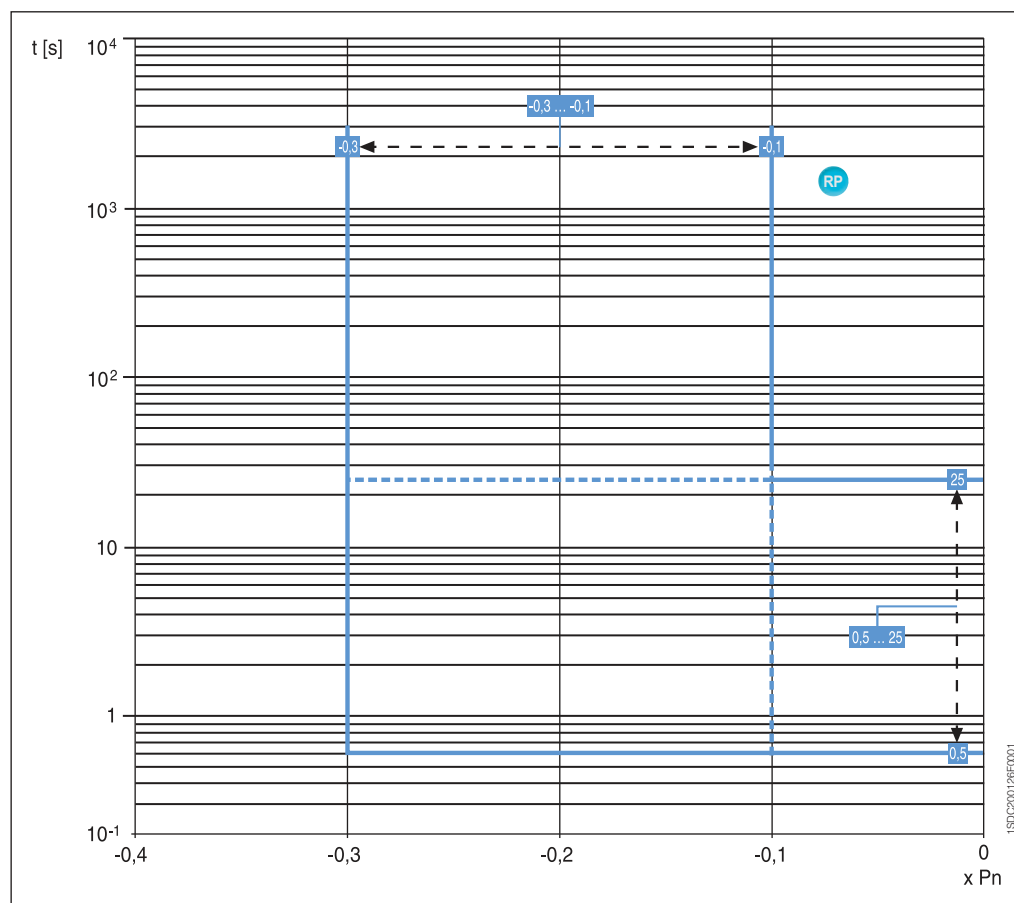

Threshold and trip times tolerances page 4/27

Accessories for protection trip units

Optional modules

PR122 and PR123 can be enriched with additional internal modules, increasing the capacity of the trip unit and making these units highly versatile.

Electrical signalling contacts: PR120/K Internal Module

This unit, internally connected to PR122/P and PR123/P, allows the remote signalling of alarms and trips of the circuit breaker.

Four independent power relays provided on the PR120/K trip unit enable electrical signalling of the following:

- timing for protections L, S, G (and UV, OV, RV, RP, D, U, OF, UF where applicable);
- protections L, S, I, G, OT, (and UV, OV, RV, RP, D, U, OF, UF where applicable) tripped and other events;
- in addition, by using an external device (PR010/T, BT030, PR120/D-BT), the contacts can be freely configured in association with any possible event or alarm.

PR120/K can also be used as actuator for the Load control function.

In addition the unit can be provided with a digital input signal, enabling the following functions:

- activation of alternative set of parameter (PR123/P only);
- external trip command
- trip reset of the trip unit
- reset of PR120/K power relays

When the digital input is required the power relays have a common connection (see circuit diagrams Chapter 8).

This latest kind of connection must be specified in the order when required together with the circuit breaker. When PR120/K is ordered as loose accessory both of the configurations are possible.

The auxiliary 24VDC power supply is needed for the unit (shown by a green Power LED). Four yellow LEDs show the status of each output relay.

The use of Voltage Transformers is mandatory for rated voltages higher than 690V.

The PR120/K can not work with the IO o/c internal contacts.



1SDC200300F0001

Specifications of the signalling relays

Type	Monostable STDP
Maximum switching power (resistive load)	100 W/1250 VA
Maximum switching current	5 A
Switching capacity (resistive load)	@ 30V DC 3.3 A @ 250V AC 5 A
Contact/coil insulation	2000 V eff (1 min @ 50 Hz)

PR120/V Measurement Module

This optional internal module can be added to PR122, and it is supplied as standard in PR123. It measures and processes the phase and neutral voltages, are transferring these values to the protection trip unit by means of its internal bus in order to achieve a series of protection and measurement features.

It can be connected at any time to PR122/P, which recognizes it automatically without the need of any configuration.

PR122 does not normally require any external connection or Voltage Transformer, since it is connected internally to the lower terminals of Emax. When necessary, the connection of voltage pick-ups can be moved to any other points (i.e. upper terminals), by using the alternative connection located in the terminal box.

When ordered as a loose accessory, PR122 is provided with all the possible connections, internal or through the terminal box.

The module is provided with a Power LED and a sealable switch-disconnector for the dielectric test.



1SDC20014F0001



Accessories for protection trip units



1SDD20001F0001

PR120/D-M Communication Module

PR120/D-M communication module is the solution for connecting Emax to a Modbus network, allowing the remote supervision and control of the circuit-breaker.

It is suitable for PR122/P and PR123/P trip units. As for PR120/V this module can be added at any time to the protection trip unit and its presence is automatically recognized. When ordered separately from the circuit-breakers it is supplied complete of all the accessories needed for its installation, such as precabled auxiliary switches and cables for signalling the circuit-breaker status (springs, position inserted). Refer to circuit diagram page 8/12 for details about connections. The module can be powered by means of a 24V DC auxiliary supply.

The list of available functions can be found on page 4/42.

It is provided with three LEDs on the front side:

- Power LED
- Rx/Tx LEDs



1SDD20002F0001

PR120/D-BT Wireless Communication Module

PR120/D-BT is the innovative wireless communication module, based on Bluetooth standard. It allows the communication among the PR122/P and PR123/P Protection trip units and a PDA or a Notebook with a Bluetooth port. This device is dedicated to the use with SD-Pocket application (see in the following the features of this application).

The module can be powered by means of a 24V DC auxiliary supply or by means of PR030/B battery unit.

It is provided with four LEDs on the front side:

- Power LED
- Rx/Tx LEDs
- Bluetooth LED, showing the activity of Bluetooth communication

PR120/D-BT can be connected at any time to the protection trip unit.

BT030 Communication unit

BT030 is a device to be connected on Test connector of PR121/P, PR122/P and PR123/P. It allows Bluetooth communication among the Protection trip unit and a PDA or a Notebook with a Bluetooth port. BT030 can also be used with Tmax circuit breakers equipped with PR222DS/PD. This device is dedicated to the use with SD-Pocket application.

BT030 can provide the power supply needed to energize itself and the protection trip unit by means of a Li-ion rechargeable battery.

PR030/B power supply unit

This accessory, always supplied with the PR122 and PR123 range of trip units, makes it possible to read and configure the parameters of the unit whatever the status of the circuit-breaker (open-closed, in test isolated or racked-in position, with/without auxiliary power supply). PR030/B is also needed for reading trip data if the trip occurred more than 48 hours earlier and the trip unit was no longer powered.

An internal electronic circuit supplies the unit for approximately 3 consecutive hours for the sole purpose of reading and configuring data.

In relation to the amount of use, battery life decreases if the SACE PR030/B accessory is also used to perform the Trip test & Auto test.

Interface from front of HMI030 panel

This accessory, suitable for all protection trip units, is designed for the installation on the front side of the switchboard. It consists of a graphic display where all the measurements and alarms/events of the trip unit are shown. The user can browse the measurements by using the navigation pushbuttons, similarly to PR122/P and PR123/P. Thanks to the high precision level, the same of the protection trip units, the device can replace the traditional instrumentation, without the need for current/voltage transformers. The unit requires only a 24 V DC power supply. In fact HMI030 is connected directly to the protection trip unit via a serial line.



1SD200129F0001

SACE PR010/T configuration test unit

The SACE PR010/T unit is an instrument capable of performing the functions of testing, programming and reading parameters for the protection units equipping SACE Emax low-voltage air circuit-breakers.

In particular, the test function involves the following units:

- PR121 (all versions)
- PR122 (all versions)
- PR123 (all versions)

whereas the parameter programming and reading functions regard the range of PR122 and PR123 trip units.

All of the functions mentioned can be carried out “on board” by connecting the SACE PR010/T unit to the front multi-pin connector on the various protection units. Special interfacing cables supplied with the unit must be used for this connection.

The human-machine interface takes the form of a touchpad and multi-line alphanumeric display.

The unit also has two LEDs to indicate, respectively:

- POWER-ON and STAND BY
- battery charge state.

Two different types of test are available: automatic (for PR121, PR122 and PR123) and manual. By connection to a PC (using the USB 512 MB supplied by ABB SACE), it is also possible to upgrade the software of the SACE PR010/T unit and adapt the test unit to the development of new products.

It is also possible to store the most important test results in the unit itself, and to send a report to the personal computer with the following information:

- type of protection tested
- threshold selected
- curve selected
- phase tested
- test current
- estimated trip time
- measured trip time
- test results.

At least 5 complete tests can be stored in the memory. The report downloaded onto a PC allows creation of an archive of tests carried out on the installation.

In automatic mode, the SACE PR010/T unit is capable of testing the following with the PR122 range:

- protection functions L, S, I,
- G protection function with internal transformer,
- G protection function with toroid on the transformer star centre,
- monitoring of correct microprocessor operation.

The unit can also test the following protections of PR122 equipped with PR120/V:

- overvoltage protection function OV,
- undervoltage protection function UV,
- residual voltage protection function RV,
- phase unbalance protection function U.

The SACE PR010/T unit is portable and runs on rechargeable batteries and/or with an external power supply (always supplied) with a rated voltage of 100-240V AC/12V DC.

The standard version of the SACE PR010/T unit includes:

- SACE PR010/T test unit complete with rechargeable batteries
- SACE TT1 test unit
- 100 - 240V AC/12V DC external power supply with cord
- cables to connect the unit and connector
- cable to connect the unit and computer (RS232 serial)
- user manual and USB 512 MB containing application software
- plastic bag.



Accessories for protection trip units

Flex Interfaces

ABB SACE Flex Interfaces are a range of 10 modular DIN rail electronic devices, thought up for signaling and transmitting information between circuit-breakers and other devices, such as actuators, communication networks and measuring instruments.

Thanks to this function, it is possible to make simple and economic the applications like:

- electrical signalling of events, alarms and circuit-breaker trips;
- transmission of electrical measurements to switchboard instruments, or remote control, by means of 4-20 mA signals;
- additional protection of the plant based on measurements of external values, such as pressure and temperature;
- non-priority load control.

According to the methods of connection to the moulded-case and air circuit-breakers, the devices in the Flex Interface family, are identified in:

- Accessory Devices (ADs) which are connected to the electronic trip unit by means of an interfacing unit.
- System Devices (SDs) which are connected by means of an external communication bus to data managing unit (like a Personal Computer, a PLC or a SCADA).
- Local Device (LD) which is connected directly to the trip unit.

To complete the Flex Interface range, the HMI030 switchboard multimeter is also available, which allows display of all the measurements managed by the trip unit it is connected to.

The dimensions of all Flex Interface devices are four modular units, with simple and immediate cabling, and require an auxiliary power supply at 24 V DC to function.

The Accessory Devices family (ADs) has 3 modular devices AD030DO, AD030AO and AD030MI, able to add analog and/or digital output and input to the circuit breaker's trip unit connected to the interface MM030.

MM030 is able to manage the data exchange with all the Emax trip units.

- AD030 DO: the module periodically receives signals from the trip unit, updates the eight digital outputs and then the associated LEDs;
- AD030 AO: the unit is able to convert the measurement signals which come from the trip unit into 4-20 mA electrical signals, such as currents, voltages, power, peak factor, energy and frequency. Four analog outputs are available;
- AD030 MI: acquiring signals coming from the external field, the device can convert these into two analog and two digital inputs to be sent to the electronic trip unit in order to obtain protections and signalling.
- MM030: this device is always necessary when the Accessory Devices are present. This module is the interface between the circuit-breaker trip unit and the other ADs.

The System Devices are modular devices connected to an external communication bus, to which a device, such as a Personal Computer, PLC or SCADA is connected. It is possible to acquire data in real time with digital and/or analog input and to use some digital and/or analog inputs to activate electro-mechanical devices or to visualize electrical measures remotely.

There are 5 devices:

- SD030 DX: the main device in the System Devices family. It manages five digital inputs and three digital outputs. It allows remote supervision and activation of switch-disconnectors and circuit-breakers without the communication function by means of a SCADA or PLC.
- SD030 DO: the module receives data from a PLC and consequently activates the eight digital outputs.
- SD030 DI: the module receives data from the external field and transmits them to a main system connected by means of a system bus. Up to eight digital input signals are available.



- SD030 AO: the device acquires data from external devices and then activates the four analog outputs (4-20 mA or 0-20 mA electrical signalling).
- SD030 MI: the device acquires data from the external field and communicates them to a remote supervision system. Two analog inputs and two digital inputs are available.

The Local Device LD030 DO is a module, fitted with eight digital outputs, which can be connected to all the electronic trip units of Emax circuit-breakers and PR222DS/PD, PR223DS, PR223EF, PR331/P and PR332/P trip units of Tmax circuit-breakers, allowing external signalling of a very wide range of information and events recorded by the trip unit.

The switchboard multimeter HMI030 completes the Flex interfaces family allowing remote display of the electric measurements detected by the trip unit. The module can be configured using different methods: ammeter, voltmeter, wattmeter and, finally, "custom". Apart from allowing display of currents, voltages and powers, the "custom" method allows access to further information, among which frequency, power factor and energy.



Communication devices and systems

Industrial networking and ABB SACE Emax

In addition to providing flexible and safe protection of power installations, ABB SACE Emax electronic trip units have an extended range of communication features, which opens the way for connection of circuit-breakers to the world of industrial communication.

PR122 and PR123 electronic trip units can be fitted with communication modules, which make it possible to exchange data and information with other industrial electronic devices by means of a network.

The basic communication protocol implemented is Modbus RTU, a well-known standard of widespread use in industrial automation and power distribution equipment. A Modbus RTU communication interface can be connected immediately and exchange data with the wide range of industrial devices featuring the same protocol.

ABB products featuring the Modbus RTU protocol include:

- low voltage circuit breakers such as Emax,
- Medium Voltage protection devices
- sensors,
- automation I/O systems,
- power meters and other measurement devices,
- intelligent devices such as PLCs,
- operator interfaces
- supervision and control systems.

And if other communication protocols are required, the ABB Fieldbus Plug system is also available: intelligent field bus protocols such as Profibus-DP and DeviceNet thus become immediately available.

The power of industrial networking

The communication network can be used to read all information available in the protection trip unit, from any location connected to the bus and in real time:

- circuit-breaker status: closed, open, opened by protection trip unit trip
- all values measured by the protection trip unit: RMS currents, voltages, power, power factor and so on
- alarms and prealarms from protection trip unit, e.g., overload protection alarm (timing to trip or prealarm warning)
- fault currents in case of circuit-breaker opening on a protection trip
- number of operations performed by the circuit-breaker, with indication of the number of trips per protection type (short-circuit, overload, etc.)
- complete settings of the protection trip unit
- estimate of the residual life of circuit-breaker contacts, calculated on the basis of interrupted currents

Remote control of circuit-breakers is possible: commands to open, close and reset alarms can be issued to the circuit-breaker and protection trip unit. Close commands are executed only after a security check (e.g., that there are no diagnostic alarms active on the trip unit).

It is also possible to change the settings of the protection trip unit remotely by means of the communication bus.

All remote commands can be disabled by a "local" configuration feature, for safety of operators and installation.



1SDC20008FF0001

Circuit-breakers with communication can easily be integrated with automation and supervision systems. Typical applications include:

- supervision of the installation with continuous data logging (values of currents, voltage, power) and event logging (alarms, faults, trip logs). Supervision can be limited to low voltage devices or include medium voltage and possibly other kinds of industrial apparatus
- predictive maintenance, based on number of operations of each circuit-breaker, interrupted currents and estimate of residual equipment life
- load shedding and demand side management under control of PLC, DCS or computers.

Communication products for ABB SACE Emax

ABB SACE has developed a complete series of accessories for the Emax family of electronic trip units:

- PR120/D-M communication module
- EP010 – FBP.

Furthermore, a new generation of software dedicated to installation, configuration, supervision and control of protection trip units and circuit-breakers is now available:

- SD-View 2000
- SD-Pocket
- SD-TestBus2.

System architecture for plant supervision and control

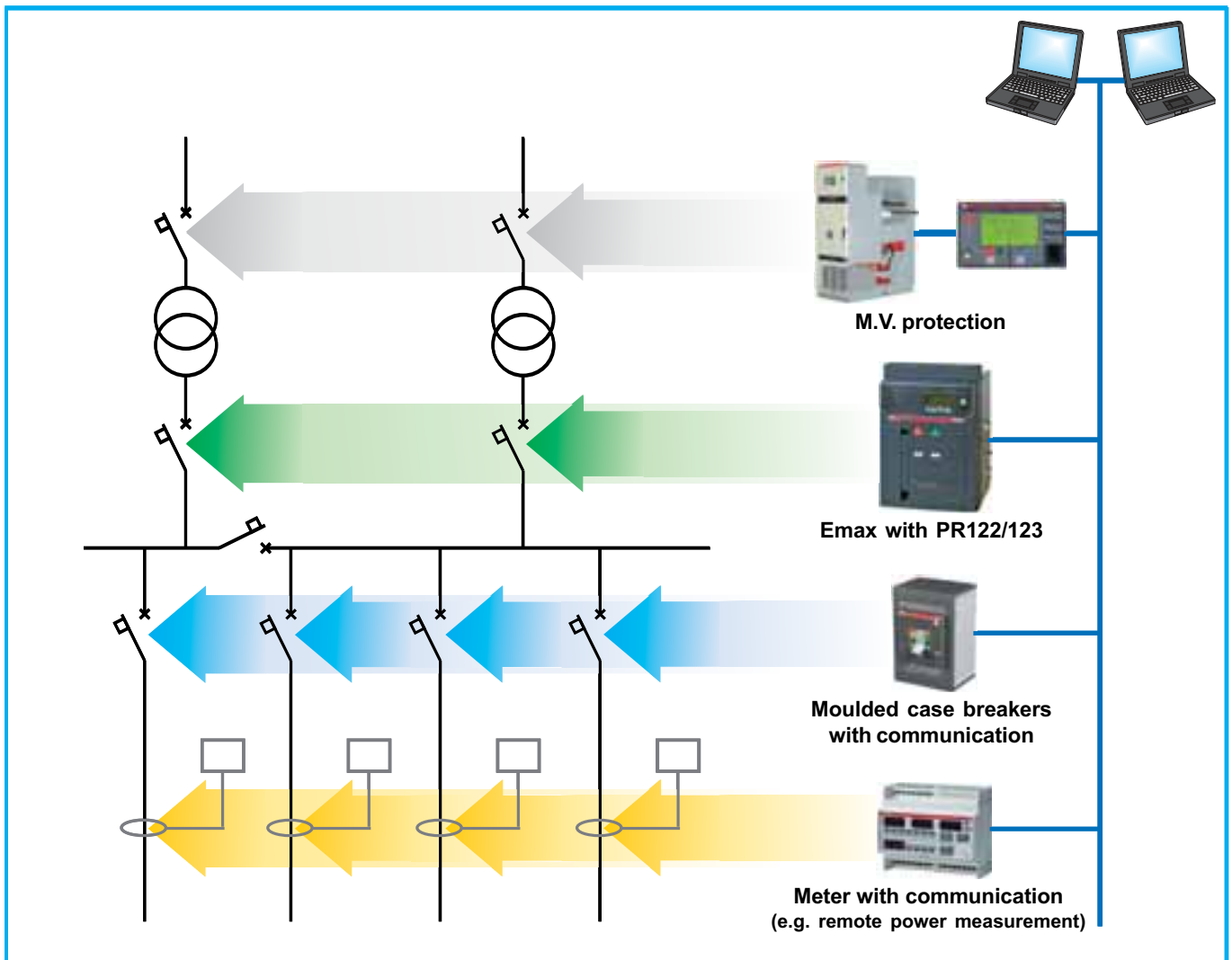



Communication devices and systems



1SDC200304R0001

PR120/D-M

PR120/D-M is the new communication module for PR122/P and PR123/P protection trip units. It is designed to allow easy integration of the Emax circuit-breakers in a Modbus network. The Modbus RTU protocol is of widespread use in the power as well as the automation industry. It is based on a master/slave architecture, with a bandwidth of up to 19200 Kbytes/sec. A standard Modbus network is easily wired up and configured by means of an RS485 physical layer. ABB SACE trip units work as slaves in the field bus network. All information required for simple integration of PR120/D-M in an industrial communication system are available on the ABB Web page.

BT030-USB

BT030-USB is a device to be connected to the Test connector of PR121/P, PR122/P and PR123/P. It allows Bluetooth communication between the Protection trip unit and a PDA or a Notebook with a Bluetooth port. BT030-USB can also be used with Tmax circuit-breakers equipped with PR222DS/PD. This device is dedicated to use with the Sd-Pocket application. It can provide the auxiliary supply needed to energize the protection trip unit by means of rechargeable batteries.

EP 010 - FBP

EP 010 – FBP is the Fieldbus Plug interface between the Emax protection trip units and the ABB Fieldbus Plug system, allowing connection of Emax Circuit-breakers to a Profibus, DeviceNet, or AS-I field bus network. EP 010 – FBP can be connected to the new Emax PR122 and PR123 protection trip units (the PR120/D dialogue module is required).



1SDC200305R0001

The ABB Fieldbus Plug concept is the latest development in industrial communication systems. All devices feature a standard connection socket, to which a set of interchangeable “smart” connectors can be plugged. Each connector is fitted with advanced electronics implementing the communication interface towards the selected field bus. Selecting a communication system is made as easy as selecting and connecting a plug. Communication systems currently available are Profibus-DP, DeviceNet and AS-i. More are being developed.

Measurement, signalling and available data functions

Measurement, signalling and available data functions available on PR122/P, PR123/P trip units with PR120/D-M and EP010 – FBP are listed in the table below:

	PR122/P + PR120/D-M	PR123/P + PR120/D-M	PR122/P-PR123/P + PR120/D-M and EP 010
Communication functions			
Protocol	Modbus RTU	Modbus RTU	FBP
Physical layer	RS-485	RS-485	Profibus-DP or DeviceNet cable
Maximum baudrate	19200 bps	19200 bps	115 Kbps
Measuring functions			
Phase currents	■	■	■
Neutral current	■	■	■
Ground current	■	■	■
Voltage (phase-phase, phase-neutral, residual)	opt. (1)	■	■
Power (active, reactive, apparent)	opt. (1)	■	■
Power factor	opt. (1)	■	■
Frequency and peak factor	opt. (1)	■	■
Energy (active, reactive, apparent)	opt. (1)	■	■
Harmonic analysis up to the 40th harmonic	■	■	■ (2)
Signalling functions			
High-voltage power supply warning alarm	■	■	■
Temperature	■	■	■
Indication for L, S, I, G and other protection	opt. (1)	■	■
Available data			
Circuit-breaker status (open, closed)	■	■	■
Circuit-breaker position (racked-in, racked-out)	■	■	■
Mode (local, remote)	■	■	■
Protection parameters set	■	■	■
Load control parameters	■	■	■
Alarms			
Protection I	■	■	■
Protection S	■	■	■
Protection J	■	■	■
Protection G	■	■	■
Anti-ratchet mechanism failure	■	■	■
Undervoltage, overvoltage and residual voltage (timing and trip) protection	opt. (1)	■	■
Reverse power protection (timing and trip)	opt. (1)	■	■
Directional protection (timing and trip)	■	■	PR123 only
Underfrequency/overfrequency protection (timing and trip)	opt. (1)	■	■
Phases rotation	■	■	■
Maintenance			
Total number of operations	■	■	■
Total number of trips	■	■	■
Number of trip tests	■	■	■
Number of manual operations	■	■	■
Number of separate trips for each protection function	■	■	■
Contact wear (%)	■	■	■
Record date of last trip	■	■	■
Operating mechanisms			
Circuit-breaker open/closed	■	■	■
Reset alarms	■	■	■
Setting of relays and protection thresholds	■	■	■
Synchronize system time	■	■	■
Events			
Status changes in circuit-breaker, protections and all alarms	■	■	■

(1) with PR120/V

(2) up to 21st harmonic and only with PR123/P



Communication devices and systems

SD-View 2000

SD-View 2000 is a "ready-to-use" system, consisting of software for personal computers, in standard configuration, which allows complete control of the low voltage electrical installation.

Putting the SD-View 2000 system into operation is quick and easy. In fact, the software itself guides the user in recognising and configuring the protection units.

The user only needs knowledge of the installation (such as how many circuit-breakers are installed and how they are connected to each other). No engineering work on the supervision system is required, since all the pages displayed are already configured in the system, ready to be used.

Usage of the software is intuitive and easy to learn for the operator: SD-View 2000 has graphic pages based on Internet Explorer, which make the system as simple to manage as surfing on the Internet.

System architecture

System architecture is based on the latest developments in personal computer and industrial communication network technology.

The ABB SACE devices are connected to the serial bus RS485 Modbus. A maximum of 31 devices can be connected to a bus. A maximum of 4 serial bus can lines be connected to a personal computer which works as data server, reading and storing the data received from the devices. The server is also used as the operator station, from where the data can be displayed and printed, commands can be sent to the devices, and all the operations needed to manage the installation can be carried out.

The server can be connected to a local network together with other personal computers which work as additional operator stations (clients). In this way, installation supervision and control can be carried out with total reliability from any station connected to the network on which SD-View 2000 is installed.

4

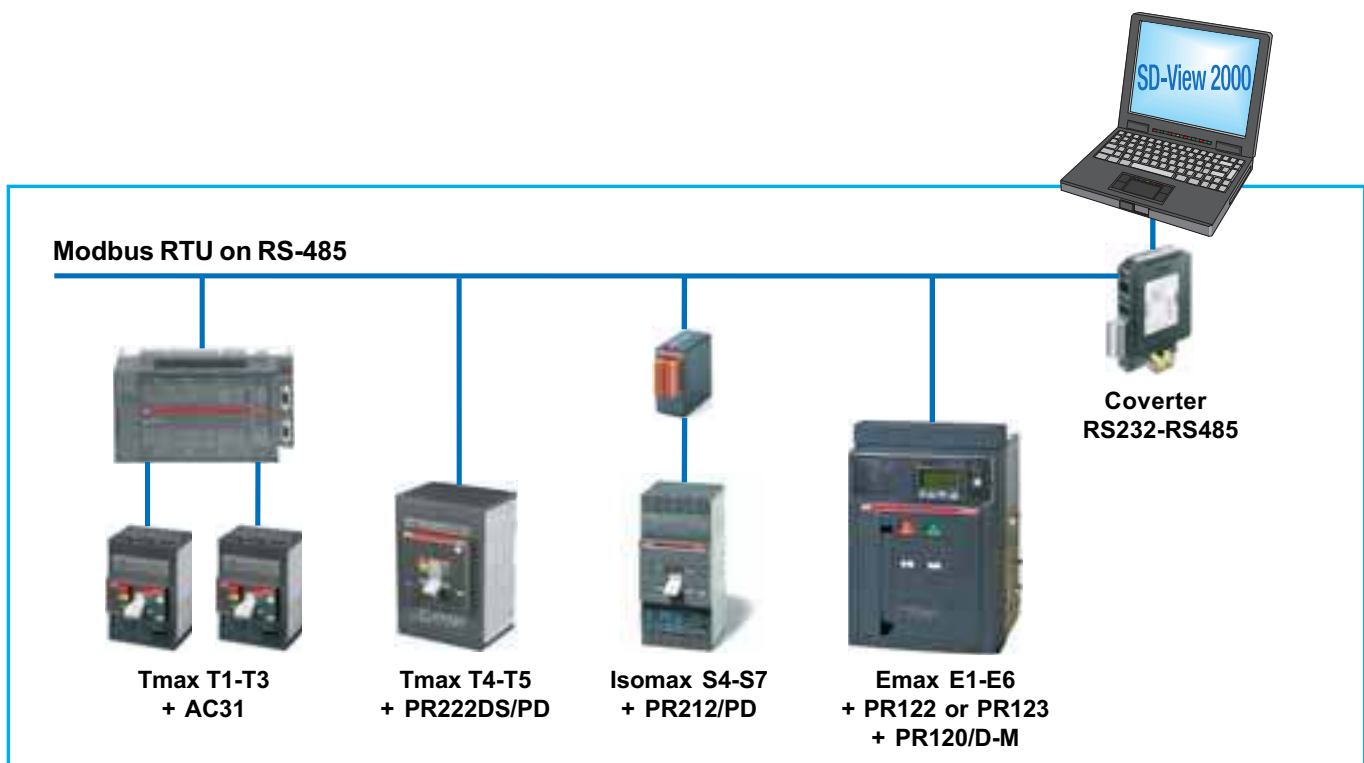

Complete control of the installation

SD-View 2000 is the ideal tool available to managers, in order to have the situation of the installations under control at all times and to be able to control all the functions easily and in real time.



The SD-View 2000 operator station (personal computer) allows information from the installation to be received and to control the circuit-breakers and relative trip units. In particular, it is possible to:

- Send opening and closing commands to the circuit-breakers
- Read the electrical installation values (current, voltage, power factor, etc.)
- Read and modify the trip characteristics of the protection units
- Determine the status of the apparatus (open, closed, number of operations, trip for fault, etc.)
- Determine abnormal operating situations (e.g. Overload) and, in the case of the trip units tripping, the type of fault (short-circuit, earth fault, value of the uninterrupted currents, etc.)
- Log the history of the installation (energy consumption, most highly loaded phase, any warnings of anomalies or faults, etc.)

- Show the temporal evolution of the installation by means of graphs. Access to the various system functions can be enabled by means of secret codes or passwords with different levels of authorisation.

Usage of the system is really simple thanks to the user interface based on Internet explorer. The graphic pages relative to each circuit-breaker are particularly intuitive and easy to use.

Devices which can be connected

The circuit-breakers with electronic trip units which can be interfaced with SD-View 2000 are:

- Emax LV air circuit-breakers from E1 to E6 fitted with PR122/P or PR123/P trip units with Modbus RTU PR120/D-M communication unit
- Emax LV air circuit-breakers from E1 to E6 fitted with PR112/PD or PR113/PD Modbus trip units
- Tmax LV moulded-case circuit-breakers T4 and T5 fitted with PR222/PD trip unit
- Isomax LV circuit-breakers from S4 to S7 fitted with PR212/P trip unit with Modbus RTU PR212/D-M communication unit.

In addition, SD-View 2000 can acquire current, voltage and power measurements in real time from the MTME-485 multimeters with Modbus communication

Furthermore, it is possible to interface any air or moulded-case circuit-breaker or switch-disconnector, not fitted with electronics, with SD-View 2000 by using a PLC AC31 unit as the communication module. For the circuit-breakers or switch-disconnectors connected in this way, SD-View 2000 shows the conditions of the apparatus (open, closed, tripped, racked-in or racked-out) in real time and allows it to be operated remotely.

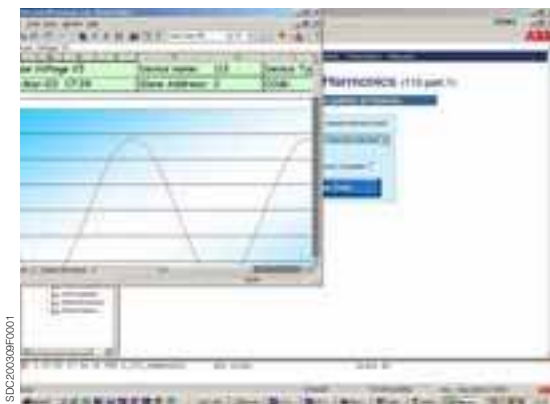



Communication devices and systems

All the characteristics of the devices listed are preconfigured in the SD-View 2000 system. The user does not therefore have to carry out any detailed configuration (i.e. insert tables with data to be displayed for each trip unit, or draft ad hoc graphic pages): simply enter the list of devices connected into the system.

Technical characteristics

Up to 4 serial ports
Up to 31 ABB SACE devices for each serial port
9600 or 19200 baud
Modbus® RTU Protocol

Personal computer requirements

Pentium 1 GHz, 256 MB RAM (512 MB recommended), 20 GB hard disk, Windows 2000, Internet Explorer 6, Ethernet card, Printer (optional)

4

SD-TestBus2

SD-TestBus2 is the ABB SACE commissioning and diagnostic software for all Modbus RTU devices. It can be used during system startup, or to troubleshoot an installed network.

SD-TestBus2 automatically scans the RS-485 bus, detects all connected devices and checks their communication settings. All possible combination of device address, parity and baud rate are checked.

A click on “scan” is enough to spot devices which are not responding, wrong addresses, misconfigured parity bits, and so on. This function is not limited to ABB SACE devices: all standard Modbus RTU devices are detected and their configuration is displayed.

After the scan, the software displays warning messages about potential problems and configuration errors, allowing complete diagnosis of a field bus network.

When ABB SACE circuit-breakers are detected, additional functions can be used to check wirings, send open/close/reset commands, and retrieve diagnostic information.

This user-friendly tool makes commissioning of Modbus networks a breeze. SD-TestBus2 is freeware and can be downloaded from the ABB SACE'S website (<http://www.abb.com>).



Emmax



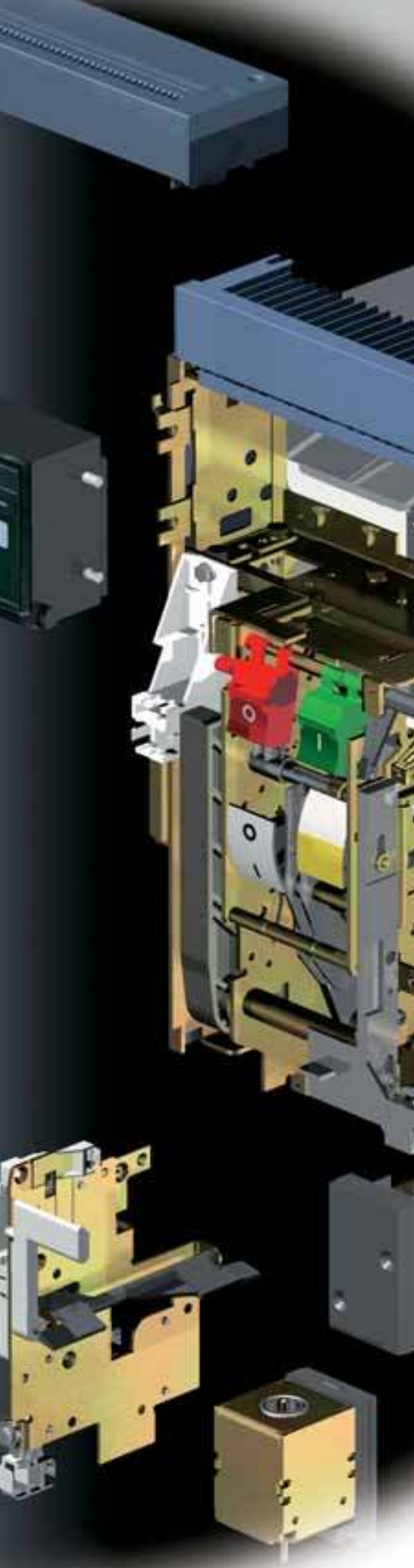

Contents

Functions of the accessories	5/2
Accessories supplied as standard	5/3
Accessories supplied on request	5/4
Shunt opening and closing release	5/6
Undervoltage release	5/8
Geared motor for the automatic charging of closing springs	5/10
Signalling of overcurrent release tripped	5/11
Auxiliary contacts	5/12
Transformers and operation counters	5/15
Mechanical safety locks	5/16
Transparent protective covers	5/18
Interlock between circuit-breakers	5/19
Automatic transfer switches - ATS021 and ATS022	5/22
Spare parts and Retrofitting	5/24



Functions of the accessories

The table below lists a few functions that can be obtained by selecting the appropriate accessories from among those provided. Several of the functions listed may be needed at the same time, depending on how the circuit-breaker is used. See the relative section for a detailed description of the individual accessories.

Function	Components
Remote control	<ul style="list-style-type: none"> • Opening release • Closing release • Geared motor for automatic charging of the closing springs
Remote signalling or actuation of automatic functions depending on the state (open-closed-tripped) or position (<i>racked-in</i> , <i>test isolated</i> , <i>racked-out</i>) of the circuit-breaker.	<ul style="list-style-type: none"> • Circuit-breaker open-closed auxiliary contacts • Circuit-breaker <i>racked-in</i>, <i>test isolated</i>, <i>racked-out</i> auxiliary contacts (withdrawable circuit-breaker only) • Contact for electrical signalling of overcurrent release tripped • Contact for signalling undervoltage release de-energized • Contact for signalling springs charged
Remote opening for various needs, including: – manual emergency control – opening dependent on tripping of other interruption devices or system automation needs ⁽¹⁾ .	<ul style="list-style-type: none"> • Opening or undervoltage release
Automatic opening of the circuit-breaker for undervoltage (for example, when operating asynchronous motors)	<ul style="list-style-type: none"> • Instantaneous or time delay undervoltage release ⁽²⁾ • Contact for signalling undervoltage release energized
Increased degree of protection	<ul style="list-style-type: none"> • IP54 door protection
Mechanical safety locks for maintenance or functional requirements for interlocking two or more circuit-breakers	<ul style="list-style-type: none"> • Key lock in open position • Padlock device in open position • Key lock and padlocks in <i>racked-in</i>, <i>test isolated</i>, <i>racked-out</i> position
Automatic switching of power supplies	<ul style="list-style-type: none"> • Mechanical interlock between two or three circuit-breakers • Automatic transfer switches - ATS021-ATS022

(1) Examples:
– circuit-breakers on Low Voltage side of parallel transformers that must open automatically when the Medium Voltage side device opens.
– automatic opening for control by external relay (undervoltage, residual current, etc.).

(2) The time-delay device is recommended when unwanted operation due to temporary voltage drops, is to be avoided (for functional or safety reasons).



Accessories supplied as standard

The following standard accessories are supplied depending on the circuit-breaker version:

Fixed circuit-breaker:

- flange for switchgear compartment door (IP30)
- support for service trip units
- four auxiliary contacts for electrical signalling of circuit-breaker open/closed (for automatic circuit-breakers only)
- terminal box for connecting outgoing auxiliaries
- mechanical signalling of overcurrent release tripped (*)
- horizontal rear terminals
- lifting plate

Note:

(*) Not supplied with the switch disconnector.

Withdrawable circuit-breaker:

- flange for switchgear compartment door
- support for service trip units
- four auxiliary contacts for electrical signalling of circuit-breaker open/closed (for automatic circuit-breakers only)
- sliding contacts for connecting outgoing auxiliaries
- mechanical signalling of overcurrent release tripped (*)
- horizontal rear terminals
- anti-insertion lock for circuit-breakers with different rated currents
- racking-out crank handle
- lifting plate

Note:

(*) Not supplied with the switch disconnector.



Accessories supplied on request

The ranges	Automatic circuit-breakers	
	Circuit-breakers with full-size neutral	
	Circuit-breakers for applications up to 1150V AC	
Circuit-breaker version	Fixed	Withdrawable
1a) Shunt opening/closing release (YO/YC) and second opening release (YO2)	■	■
1b) SOR release	■	■
2a) Undervoltage release (YU)	■	■
2b) Time-delay device for undervoltage release (D)	■	■
3) Geared motor for the automatic charging of the closing springs (M)	■	■
4a) Electrical signalling of electronic release tripped	■	■
4b) Electrical signalling of electronic release tripped with remote reset command	■	■
5a) Electrical signalling of circuit-breaker open/closed (1)	■	■
5b) External supplementary electrical signalling of circuit-breaker open/closed	■	■
5c) Electrical signalling of circuit-breaker racked-in/test isolated/racked-out	■	■
5d) Contact signalling closing springs charged	■	■
5e) Contact signalling undervoltage release de-energized (C. Aux YU)	■	■
6a) Current sensor for neutral conductor outside circuit-breaker	■	■
6b) Homopolar toroid for the main power supply earthing conductor (star center of the transformer)	■	■
6c) Homopolar toroid for residual current protection	■	■
7) Mechanical operation counter	■	■
8a) Lock in open position: key	■	■
8b) Lock in open position: padlocks	■	■
8c) Circuit-breaker lock in racked-in/racked-out/test isolated position		■
8d) Accessories for lock in racked-out/test isolated position		■
8e) Accessory for shutter padlock device		■
8f) Mechanical lock for compartment door	■	■
9a) Protection for opening and closing pushbuttons	■	■
9b) IP54 door protection	■	■
10) Mechanical interlock (2)	■	■
11) Lift device	■	■
12) Automatic transfer switch - ATS021 and ATS022 (3)	■	■

CAPTION

- Accessory on request for fixed circuit-breaker or moving part
- Accessory on request for fixed part
- Accessory on request for moving part

Shunt opening and closing release

1a) Shunt opening and closing release (YO/YC) and second opening release (YO2)

(1) The minimum impulse current duration time in instantaneous service must be 100 ms

(2) If the opening release is permanently connected to the power supply, wait at least 30 ms before sending the command to the shunt closing release.

Allows remote control opening or closing of the apparatus, depending on the installation position and connection of the releases on the support. The release can, in fact, be used for either of these two applications. Given the characteristics of the circuit-breaker operating mechanism, opening (with the circuit-breaker closed) is always possible, whereas closing is only possible when the closing springs are charged. The release can operate with direct current or alternating current. This release provides instantaneous operation ⁽¹⁾, but can be powered permanently ⁽²⁾.

Some installations require very high safety in controlling circuit-breaker opening remotely. In particular, the control and opening release circuits must be duplicated. To meet these needs, SACE Emax circuit-breakers can be equipped with a second shunt opening trip unit, fitted with a special support to hold it, that can house the standard shunt closing and opening releases. The seat of the second shunt opening release is that of the undervoltage release, which is therefore incompatible with this type of installation. The special support, including the second shunt opening release, is installed in place of the standard support.

The technical specifications of the second shunt opening release remain identical to those of the standard shunt opening release.

When used as a permanently powered closing release, it is necessary to momentarily de-energize the shunt closing release in order to close the circuit-breaker again after opening (the circuit-breaker operating mechanism has an anti-pumping device).

Reference figure in electrical circuit diagrams: YO (4) - YC (2) - YO2 (8)



1SDC200131F0001



1SDC200132F0001

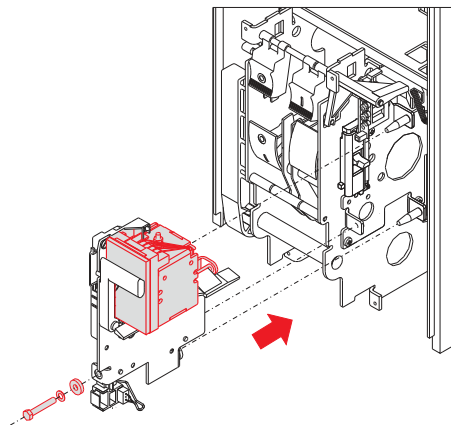

1SDC200133F0001

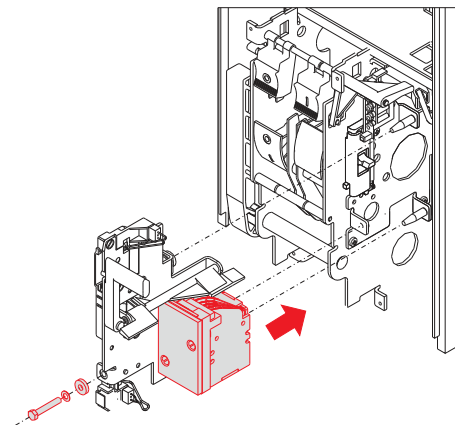

1SDC200134F0001

Characteristics		
Power supply (U _n)	30 V AC/DC	220-240 V AC/DC
Power supply (U _n)	60 V AC/DC	380-400 V AC
Operating limits: (IEC EN 60947-2 Standards)	(YO-YO2): 70% ... 110% U _n	(YC): 85% ... 110% U _n
Impulse power (P _i)	DC = 50 W	AC = 50 VA
Impulse time (t _i)	DC = 100 ms	AC = 100 ms
Continuous power (P _c):	DC = 5 W	AC = 5 VA
Maximum time to close (t _{cc})	Maximum 80 ms	
Closing time (YC):	(max) 80 ms	
Insulation voltage	2500 V 50 Hz (100 min)	



1SD200139F0001

1b) SOR Test Unit

The SOR control and monitoring Test Unit helps ensure that the various versions of SACE Emax opening releases are running smoothly, to guarantee a high level of reliability in controlling circuit-breaker opening.

Under particularly severe operating conditions or simply for remote control of the circuit-breaker, the opening release is widely used as an accessory for the SACE Emax series of air circuit-breakers.

Keeping all the functions of this accessory is a necessary condition to guarantee a high level of safety in the installation: it is therefore necessary to have a device available which cyclically checks correct operation of the release, signalling any malfunctions.

The SOR control and monitoring Test Unit ensures the continuity of opening releases with a rated operating voltage between 24 V and 250 V (AC and DC), as well as the functions of the opening coil electronic circuit are verified.

Continuity is checked cyclically with an interval of 20s between tests.

The unit has optic signals via LEDs on the front, which provide the following information in particular:

- POWER ON: power supply present
- YO TESTING: test in progress
- TEST FAILED: signal following a failed test or lack of auxiliary power supply
- ALARM: signal given following three failed tests.

Two relays with one change-over are also available on board the unit, which allow remote signalling of the following two events:

- failure of a test - resetting takes place automatically when the alarm stops)
- failure of three tests - resetting occurs only by pressing the manual RESET on the front of the unit)

There is also a manual RESET button on the front of release.

The SOR Test Unit can not be used with SOR permanently powered.

Reference figure in electrical circuit diagrams: AY (61)

Characteristics

Auxiliary power supply	24 V ... 250 V AC/DC
Maximum interrupted current	6 A
Maximum interrupted voltage	250V AC



Undervoltage release



1SDC200136F0001

2a) Undervoltage release (YU)

The undervoltage release opens the circuit-breaker when there is a significant voltage drop or power failure. It can be used for remote release (using normally-closed pushbuttons), for a lock on closing or for monitoring the voltage in the primary and secondary circuits. The power supply for the trip unit is therefore obtained on the supply side of the circuit-breaker or from an independent source. The circuit-breaker can only be closed when the release is powered (closing is mechanically locked). The release can operate with direct current or alternating current.

The circuit-breaker is opened with trip unit power supply voltages of 35-70% U_n .

The circuit-breaker can be closed with a trip unit power supply voltage of 85-110% U_n .

It can be fitted with a contact to signal when the undervoltage trip unit is energized (C. aux YU - see accessory 5e).

Reference figure in electrical circuit diagrams: YU (6)

Characteristics		
Power supply (U_n):	24 V DC	120-127 V AC/DC
	30 V AC/DC	220-240 V AC/DC
	48 V AC/DC	240-250 V AC
	60 V AC/DC	380-400 V AC
	110-120 V AC/DC	440 V AC
Operating limits:	CEI EN 60947-2 Standards	
Inrush power (P_i):	DC = 200 W	
	AC = 200 VA	
Continuous power (P_c):	DC = 5 W	
	AC = 5 VA	
Opening time (YU):	30 ms	
Insulation voltage:	2500 V 50 Hz (for 1 min)	

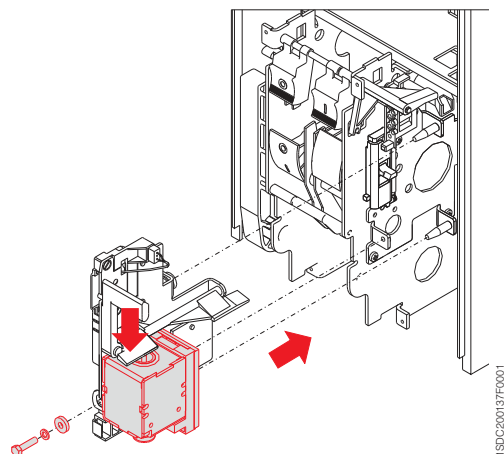

1SDC200137F0001



1SDC200138FC001

2b) Time-delay device for undervoltage release (D)

The undervoltage release can be combined with an electronic time-delay device for installation outside the circuit-breaker, allowing delayed trip unit tripping with adjustable preset times. Use of the delayed undervoltage trip unit is recommended to prevent tripping when the power supply network for the trip unit is subject to brief voltage drops or power supply failures. Circuit-breaker closing is inhibited when it is not powered. The time-delay device must be used with an undervoltage release with the same voltage.

Reference figure in electrical circuit diagrams: YU +D (7)

Characteristics	
Power supply (D)	24-30 V DC
	48 V AC/DC
	60 V AC/DC
	110-127 V AC/DC
	220-250 V AC/DC
Adjustable opening time (YU+D):	0.5-1-1.5-2-3 s



Geared motor for the automatic charging of the closing springs

3) Geared motor for the automatic charging of the closing springs (M)



1SDC200146F0001

This automatically charges the closing springs of the circuit-breaker operating mechanism. After circuit-breaker closing, the geared motor immediately recharges the closing springs. The closing springs can, however, be charged manually (using the relative operating mechanism lever) in the event of a power supply failure or during maintenance work. It is always supplied with a limit contact and microswitch for signalling that the closing springs are charged (see accessory 5d).

Reference figure in electrical circuit diagrams: M (1)

Characteristics	
Power supply	24-30 V AC/DC
	48-60 V AC/DC
	100-130 V AC/DC
	220-250 V AC/DC
Operating limits	85% - 110% U_n (CEI EN 60947-2 Standards)
Inrush power (Ps):	DC = 500 W
	AC = 500 VA
Rated power (Pn):	DC = 200 W
	AC = 200 VA
Inrush time	0.2 s
Charging time:	4-5 s
Insulation voltage:	2500 V 50 Hz (for 1 min)

5

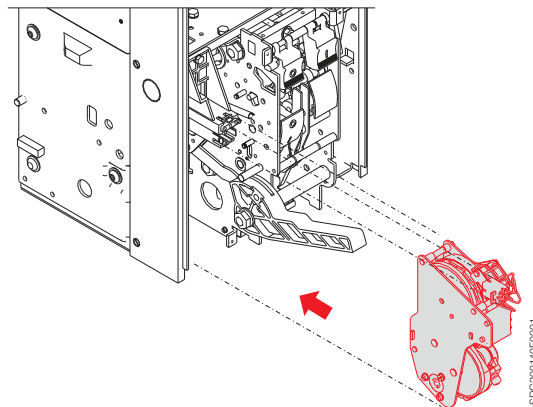

1SDC200146F0001

Signal for overcurrent releases tripped

4) Electrical signalling of electronic releases tripped

The following signals are available after the electronic trip unit has tripped:

4a) Electrical signalling of electronic trip units tripped

This allows remote signalling (electrical using switch) that the circuit-breaker is open following operation of the overcurrent releases. The mechanical signalling pushbutton must be rearmed to reset the circuit-breaker.

Reference figure in electrical circuit diagrams: S51 (13)

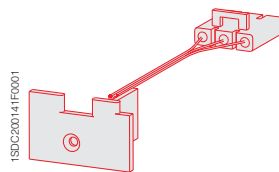

4b) Electrical signalling of electronic releases tripped with remote reset command

This allows remote signalling (electrical using switch) that the circuit-breaker is open following operation of the overcurrent releases. With this accessory, it is possible to reset the mechanical signalling pushbutton via an electrical coil from a remote command, which also allows the circuit-breaker to be reset.

Reference figure in electrical circuit diagrams: S51 (14)

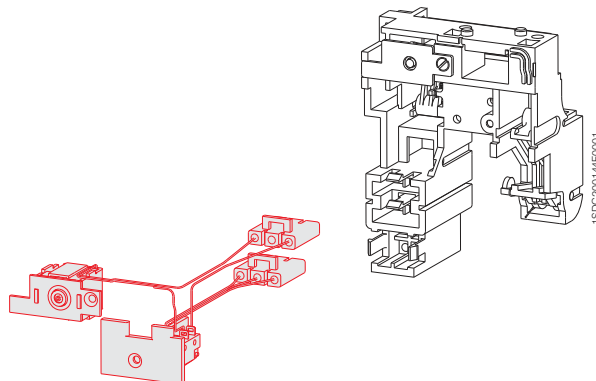

Available reset coils

220-240 V AC/DC

5



Auxiliary Contacts

5) Auxiliary contacts

Auxiliary contacts are available installed on the circuit-breaker, which enable signalling of the circuit-breaker status. The auxiliary contacts are also available in a special version for application with rated voltages $U_n < 24$ V (digital signals).

Characteristics		
U_n	I_n max	T
125 V DC	0.3 A	10 ms
250 V DC	0.15 A	
U_n	I_n max	$\cos\phi$
250 V AC	15 A	0.5

The versions available are as follows:

5a-5b) Electrical signalling of circuit-breaker open/closed

It is possible to have electrical signalling of the status (open/closed) of the circuit-breaker using 4, 10 or 15 auxiliary contacts.

The auxiliary contacts have the following configurations:

- 4 open/closed contacts for PR121 (2 normally open + 2 normally closed)
- 4 open/closed contacts for PR122/PR123 (2 normally open + 2 normally closed + 2 dedicated to trip unit)
- 10 open/closed contacts for PR121 (5 normally open + 5 normally closed)
- 10 open/closed contacts for PR122/PR123 (5 normally open + 5 normally closed + 2 dedicated to trip unit)
- 15 supplementary open/closed contacts for installation outside the circuit-breaker.

The basic configuration described above can be modified by the user for normally open or normally closed indication by repositioning the faston connector on the microswitch.

When 10 open/closed contacts for PR122/PR123 are required, the zone selectivity and PR120/K unit are not available.

Reference figure in electrical circuit diagrams: Q/1÷10 (21-22)

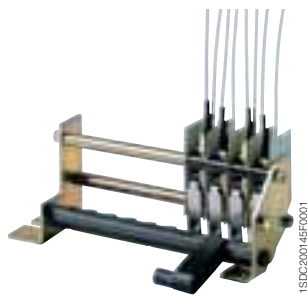

1SDC200146F0001

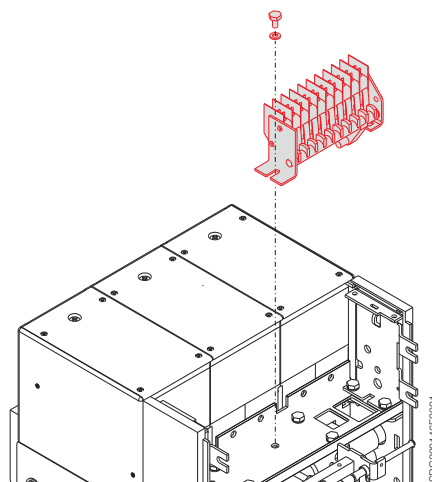

1SDC200146F0001

5c) Electrical signalling of circuit-breaker racked-in/test isolated/racked out



In addition to mechanical signalling of the circuit-breaker position, it is also possible to obtain electrical signalling using 5 or 10 auxiliary contacts which are installed on the fixed part.

It is only available for withdrawable circuit-breakers, for installation on the fixed part.

The auxiliary contacts take on the following configurations:

- 5 contacts; set comprising 2 contacts for racked-in signal, 2 contacts for racked-out signal, and 1 contact to signal the test isolated position (main pliers isolated, but sliding contacts connected).
- 10 contacts; set comprising 4 contacts for racked-in signal, 4 contacts for racked-out signal, and 2 contacts to signal the test isolated position (main pliers isolated, but sliding contacts connected).

Reference figure in electrical circuit diagrams:

S75I (31-32)

S75T (31-32)

S75E (31-32)

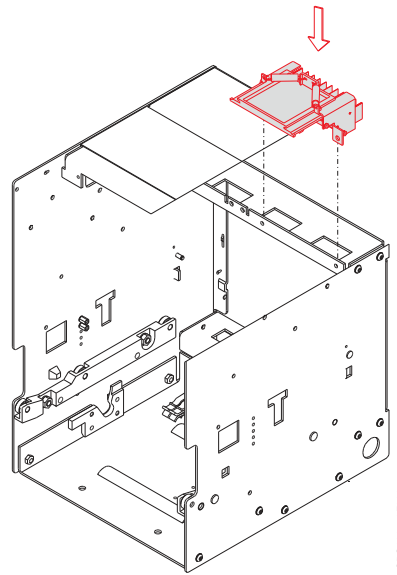



Auxiliary Contacts



1SDC200149F0001

5d) Contact for signalling closing springs charged

This is made up of a microswitch which allows remote signalling of the state of the circuit-breaker operating mechanism closing springs (always supplied with the spring charging geared motor).

Reference figure in electrical circuit diagrams: S33 M/2 (11)

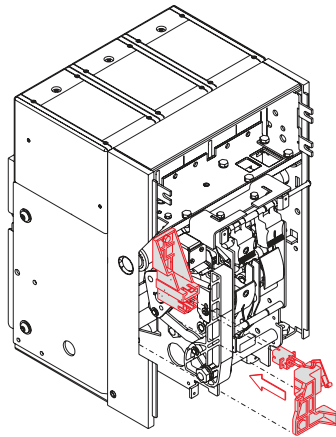

1SDC200150F0001

5



1SDC200151F0001

5e) Contact signalling undervoltage release de-energized (C.aux YU)

The undervoltage releases can be fitted with a contact (normally closed or open, as preferred) for signalling undervoltage release energized, to remotely signal the state of the undervoltage release.

Reference figure in electrical circuit diagrams: (12)

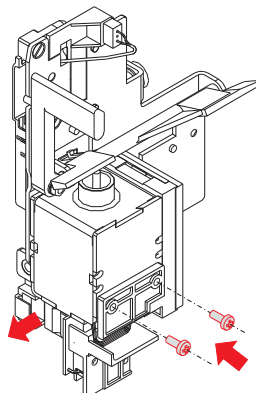

1SDC200152F0001

Transformers and operation counters

6a) Current sensor for neutral conductor outside circuit-breaker



1SDC200159F0001

For three-pole circuit-breakers only, this allows protection of the neutral by connecting it to the overcurrent release. Supplied on request.

Reference figure in electrical circuit diagrams: *UI/N* (page 8/8)

6b) Homopolar toroid for the main power supply earthing conductor (star centre of the transformer)



1SDC200154F0001

SACE PR122 and PR123 electronic trip units can be used in combination with an external toroid located on the conductor, which connects the star centre of the MV/LV transformer (homopolar transformer) to earth. In this case, the earth protection is defined as Source Ground Return. Through two different combinations of connection of its terminals (see chapter 8), the I_n of the same toroid can be set at 100 A, 250 A, 400 A, 800 A.

6c) Homopolar toroid for residual current protection



1SDC200611F0001

SACE PR122/P LSIRc, PR122/P LSIG (with PR120V) and PR123/P may be also used in combination with this accessory, enabling residual current protection. Rc protection can be activated only if the special rating plug for residual current protection and the external toroid are present.

Characteristics

5

7) Mechanical operation counter



1SDC200155F0001

This is connected to the operating mechanism by means of a simple lever mechanism, and indicates the number of mechanical operations carried out by the circuit-breaker.

The count is shown on the front of the circuit-breaker.

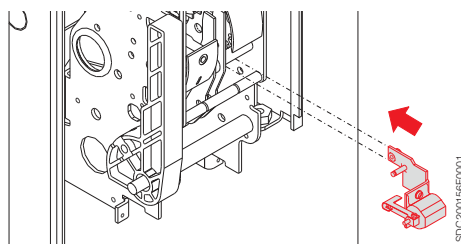

1SDC200156F0001



Mechanical safety locks

8) Mechanical safety locks

8a-8b) Lock in open position

Several different mechanisms are available which allow the circuit-breaker to be locked in the open position.

These devices can be controlled by:

- Key (8a): a special circular lock with different keys (for a single circuit-breaker) or the same keys (for several circuit-breakers). In the latter case, up to four different key numbers are available.
- Padlocks (8b): up to 3 padlocks (not supplied): \varnothing 4 mm.



1SDC200157F0001



1SDC200158F0001

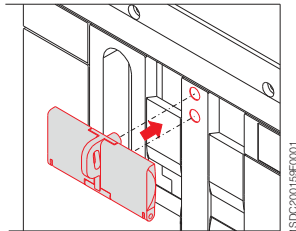

1SDC200158F0001

8c) Circuit-breaker lock in racked-in/test isolated/racked-out position

This device can be controlled by a special circular key lock with different keys (for a single circuit-breaker) or the same keys (for several circuit-breakers - up to four different key numbers available) and padlocks (up to 3 padlocks, not supplied - \varnothing 4 mm, \varnothing 6 mm, \varnothing 8 mm). It is only available for withdrawable circuit-breakers, to be installed on the moving part.

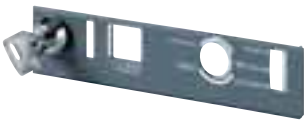

1SDC2200160F0001

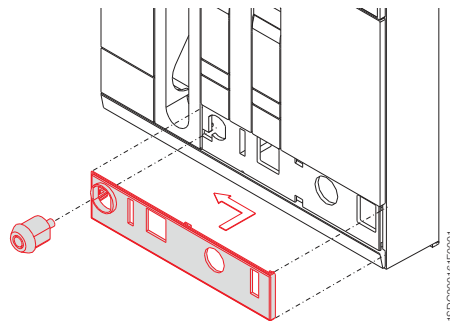

1SDC2200160F0001

8d) Accessories for lock in test isolated/racked-out position

In addition to the circuit-breaker lock in the racked-in/test isolated/racked-out position, this only allows the circuit-breaker to be locked in the racked-out or test isolated positions.

It is only available for withdrawable circuit-breakers, to be installed on the moving part.

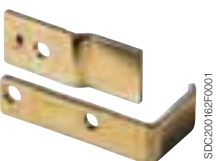

1SDC2200162F0001

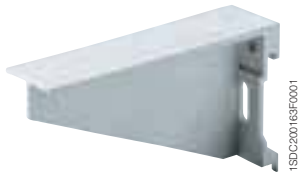

8e) Accessory for shutter padlock device

This allows the shutters (installed on the fixed part) to be padlocked in their closed position. It is only available for withdrawable circuit-breakers, to be installed on the fixed part.

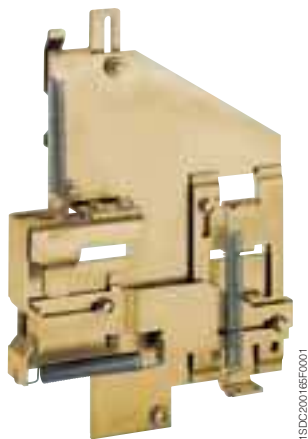
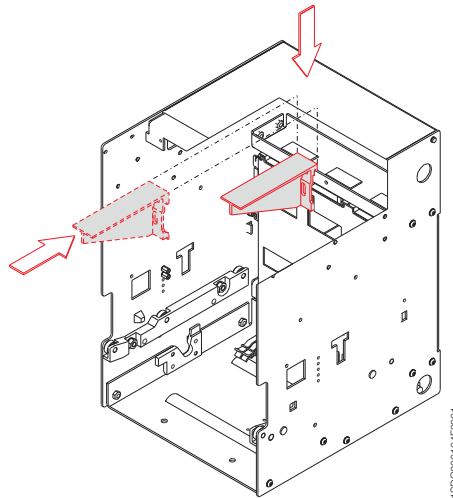

8f) Mechanical lock for compartment door

This stops the compartment door from being opened when the circuit-breaker is closed (and circuit-breaker racked in for withdrawable circuit-breakers) and prevents the circuit-breaker from being closed when the compartment door is open.



Transparent protective covers

9) Transparent protective covers

9a) Protective cover for opening and closing pushbuttons

These protections are fitted over the opening and closing pushbuttons, preventing the relative circuit-breaker operations unless a special tool is used.

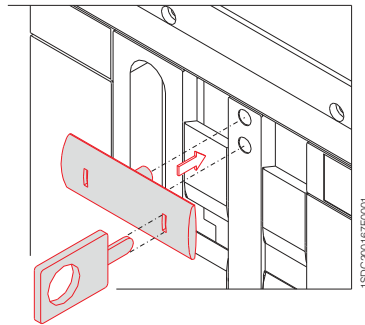

9b) IP54 door protection

This is a transparent plastic protective cover which completely protects the front panel of the circuit-breaker, with a protection rating of IP54. Mounted on hinges, it is fitted with a key lock (same or different keys).

5

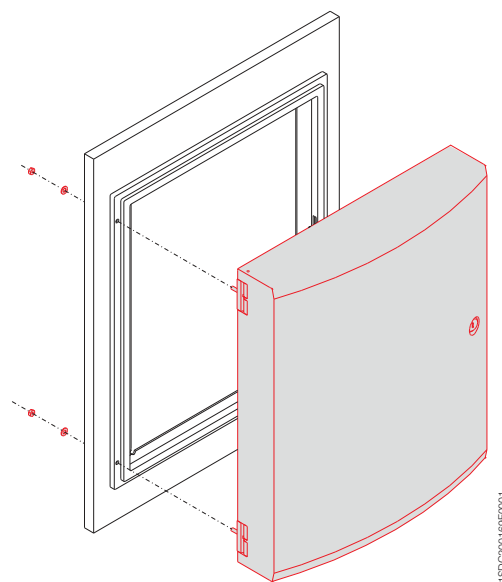

Interlock between circuit-breakers

10) Mechanical interlock

This mechanism creates a mechanical interlock between two or three circuit-breakers (even different models and different versions, fixed/withdrawable) using a flexible cable. The circuit diagram for electrical switching using a relay (to be installed by the customer) is supplied with the mechanical interlock.

The circuit-breakers can be installed vertically or horizontally. An interlock between an Emax (E1÷E6) and a T7/X1 is possible with dedicated cables.



Four types of mechanical interlocks are available:

Type B: between 3 circuit-breakers (2 power supplies + emergency power supply)

Type D: between 3 circuit-breakers (3 power supplies / one single closed CB)

Note:

See the "Overall dimensions" and "Electrical circuit diagrams" chapters for information about dimensions (fixed and withdrawable versions) and settings.

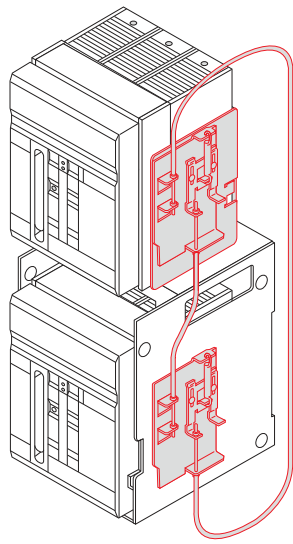

Vertical interlock

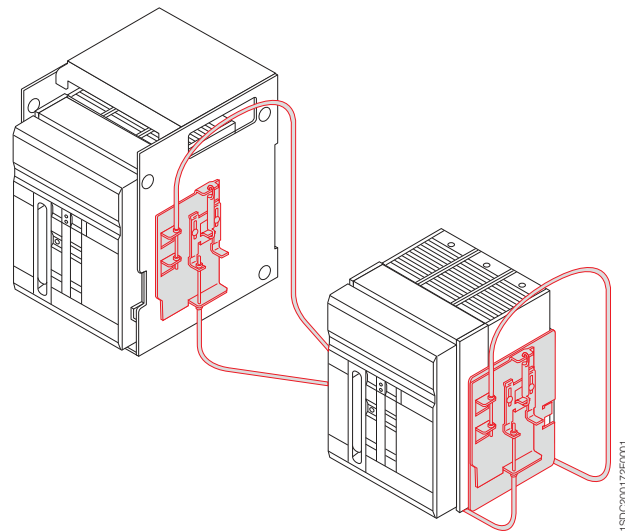

Horizontal interlock

L interlock

It is possible to make the mechanism interlock among three circuit-breakers disposed in "L position".



Interlock between circuit-breakers

The mechanical interlocks possible are shown below, depending on whether 2 or 3 circuit-breakers (any model and in any version) are used in the switching system.

Type of interlock	Typical circuit	Possible interlocks																												
Type A Between two circuit-breakers One normal power supply and one emergency power supply	<p>O = Circuit-breaker open I = Circuit-breaker closed</p>	Circuit-breaker 1 can only be closed if 2 is open, and vice-versa. <table border="1"> <thead> <tr> <th></th> <th>1</th> <th>2</th> </tr> </thead> <tbody> <tr> <th>1</th> <td>O</td> <td>O</td> </tr> <tr> <th>2</th> <td>I</td> <td>O</td> </tr> <tr> <th>3</th> <td>O</td> <td>I</td> </tr> </tbody> </table>		1	2	1	O	O	2	I	O	3	O	I																
	1	2																												
1	O	O																												
2	I	O																												
3	O	I																												
Type B Between three circuit-breakers Two normal power supplies and one emergency power supply.	<p>O = Circuit-breaker open I = Circuit-breaker closed</p>	Circuit-breakers 1 and 3 can only be closed if 2 is open. Circuit-breaker 2 can only be closed if 1 and 3 are open. <table border="1"> <thead> <tr> <th></th> <th>1</th> <th>2</th> <th>3</th> </tr> </thead> <tbody> <tr> <th>1</th> <td>O</td> <td>O</td> <td>O</td> </tr> <tr> <th>2</th> <td>I</td> <td>O</td> <td>O</td> </tr> <tr> <th>3</th> <td>O</td> <td>O</td> <td>I</td> </tr> <tr> <th>4</th> <td>I</td> <td>O</td> <td>I</td> </tr> <tr> <th>5</th> <td>O</td> <td>I</td> <td>O</td> </tr> </tbody> </table>		1	2	3	1	O	O	O	2	I	O	O	3	O	O	I	4	I	O	I	5	O	I	O				
	1	2	3																											
1	O	O	O																											
2	I	O	O																											
3	O	O	I																											
4	I	O	I																											
5	O	I	O																											
Type C Between three circuit-breakers The two half-busbars can be powered by a single transformer (bus-tie closed) or by both at the same time (bus-tie open)	<p>O = Circuit-breaker open I = Circuit-breaker closed</p>	One or two circuit-breakers out of three can be closed at the same time. <table border="1"> <thead> <tr> <th></th> <th>1</th> <th>2</th> <th>3</th> </tr> </thead> <tbody> <tr> <th>1</th> <td>O</td> <td>O</td> <td>O</td> </tr> <tr> <th>2</th> <td>I</td> <td>O</td> <td>O</td> </tr> <tr> <th>3</th> <td>O</td> <td>I</td> <td>O</td> </tr> <tr> <th>4</th> <td>O</td> <td>O</td> <td>I</td> </tr> <tr> <th>5</th> <td>I</td> <td>I</td> <td>O</td> </tr> <tr> <th>6</th> <td>I</td> <td>O</td> <td>I</td> </tr> </tbody> </table>		1	2	3	1	O	O	O	2	I	O	O	3	O	I	O	4	O	O	I	5	I	I	O	6	I	O	I
	1	2	3																											
1	O	O	O																											
2	I	O	O																											
3	O	I	O																											
4	O	O	I																											
5	I	I	O																											
6	I	O	I																											
Type D Between three circuit-breakers Three power supplies (generators or transformers) on the same busbar, so parallel operation is not allowed	<p>O = Circuit-breaker open I = Circuit-breaker closed</p>	Only one of three circuit-breakers can be closed. <table border="1"> <thead> <tr> <th></th> <th>1</th> <th>2</th> <th>3</th> </tr> </thead> <tbody> <tr> <th>1</th> <td>O</td> <td>O</td> <td>O</td> </tr> <tr> <th>2</th> <td>I</td> <td>O</td> <td>O</td> </tr> <tr> <th>3</th> <td>O</td> <td>I</td> <td>O</td> </tr> <tr> <th>4</th> <td>O</td> <td>O</td> <td>I</td> </tr> </tbody> </table>		1	2	3	1	O	O	O	2	I	O	O	3	O	I	O	4	O	O	I								
	1	2	3																											
1	O	O	O																											
2	I	O	O																											
3	O	I	O																											
4	O	O	I																											

The emergency power supply is usually provided to take over from the normal power supply in two instances:

- to power health and safety services (e.g. hospital installations);
- to power parts of installations which are essential for requirements other than safety (e.g. continuous cycle industrial plants).

The range of accessories for SACE Emax circuit-breakers includes solutions for a wide variety of different plant engineering requirements.

See the specific regulations regarding protections against overcurrents, direct and indirect contacts, and provisions to improve the reliability and safety of emergency circuits.

Switching from the normal to the emergency power supply can either be carried out manually (locally or by remote control) or automatically.

To this end, the circuit-breakers used for switching must be fitted with the accessories required to allow electric remote control and provide the electrical and mechanical interlocks required by the switching logic.

These include:

- the shunt opening release
- the shunt closing release
- the motor operator
- the auxiliary contacts.

Switching can be automated by means of a special electronically-controlled relay circuit, installed by the customer (diagrams provided by ABB SACE).

Mechanical interlocks between two or three circuit-breakers are made by using cables which can be used both for circuit-breakers side by side or superimposed.

11) Lift device

This accessory makes safety and easy the lifting of fixed circuit-breaker and mobile part thanks to telescopic plates.

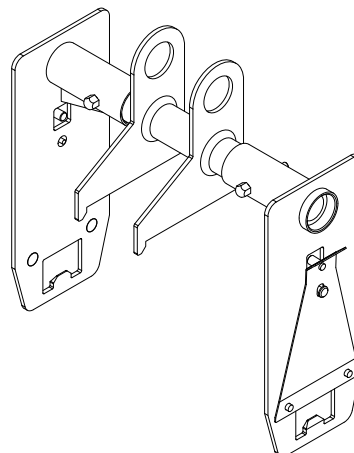



Automatic transfer switch ATS021 and ATS022

12) Automatic transfer switch - ATS021 and ATS022

The ATS (Automatic Transfer Switch) is the network-generator transfer unit used in installations where switching the main power line to an emergency one is required, to ensure power supply to the loads in the case of anomalies in the main line.

The unit is able to manage the entire transfer procedure automatically, and prepares the commands for carrying out the procedure manually as well.

In the case of an anomaly in the main line voltage, in accordance with the parameters set by the user, the opening of the circuit-breaker of the main line, the starting of the generator set (when provided) and the closing of the emergency line are performed. In the same way, in the case of the main line returning, the procedure of reverse transfer is controlled automatically.

The new generation of ATS (ATS021 and ATS022) offers the most advanced and complete solutions to guarantee service continuity. The ATS021 and ATS022 can be used both with all the circuit-breakers in the SACE Tmax XT family and with the switch-disconnectors.

The ATS021 and ATS022 devices have been designed to operate with self-supply. The ATS022 unit also prepares the connection for auxiliary power supply, which allows additional functions to be used.

The ATS021 and ATS022 devices carry out control of both the power supply lines and analyse:

- phase unbalance;
- frequency unbalance;
- phase loss.

Apart from the standard control functions, with the ATS022 unit, the following is possible:

- selecting the priority line;
- controlling a third circuit-breaker;
- incorporating the device in a supervision system with Modbus communication (auxiliary power supply is needed);
- reading and setting the parameters, and displaying the measurements and alarms, by means of a graphic display.

Typical applications for use are: power supply to UPS (Uninterrupted Power Supply) units, operating rooms and primary hospital services, emergency power supply for civil buildings, airports, hotels, data banks and telecommunication systems, power supply of industrial lines for continuous processes.

For correct configuration, each circuit-breaker connected to the ATS021 or ATS022 must be fitted with the following accessories:

- mechanical interlock;
- motorised control of opening and closing;
- key lock against just manual operation for the motor operator;
- contact for signalling the state (open/closed) and contact for tripped;
- contact for racked-in (in the case of a withdrawable version circuit-breaker).

	ATS021	ATS022
General		
Auxiliary Power Supply	Not Required	Not Required (24-110 Vdc is required only for Modbus dialogue and 16 2/3 Hz system)
Rated Voltage, Un	[VAC] Max 480	Max 480
Frequency	[Hz] 50, 60	16 2/3, 50, 60, 400
Dimensions (HxWxD)	[mm] 96x144x170	96x144x170
Type of installation	Door mounting DIN-rail mounting	Door mounting DIN-rail mounting
Operating Mode	Auto/Manual	Auto/Manual
Features		
Monitoring of the Normal and Emergency lines	%	%
Controlling CBs of the Normal and Emergency lines	%	%
Generator set startup	%	%
Generator set shutdown with adjustable delay	%	%
Bus tie	%	%
No-priority Line	%	%
Modbus RS485	%	%
Display	%	%
Ambient conditions		
Operating temperature	-20...+60 °C	-20...+60 °C
Humidity	5% - 90% without condensation	5% - 90% without condensation
Operating thresholds		
Minimum voltage	-30%...-5%Un	-30%...-5%Un
Maximum voltage	+5%...+30%Un	+5%...+30%Un
Rated frequency thresholds	-10%...+10%fn	-10%...+10%fn
Test		
Test Mode	%	%
Compliance with standards		
Electronic Adjustment for use in power installations	EN-IEC 50178	EN-IEC 50178
Electromagnetic compatibility	EN 50081-2 EN 50082-2	EN 50081-2 EN 50082-2
Environmental conditions	IEC 68-2-1 IEC 68-2-2 IEC 68-2-3	IEC 68-2-1 IEC 68-2-2 IEC 68-2-3



Spare parts and retrofitting

Spare parts

The following spare parts are available:

- front metal shields and escutcheon plate
- opening solenoid for PR121, PR122 and PR123 overcurrent release
- arcing chamber
- closing springs
- jaw-type isolating contact for the fixed part of the withdrawable circuit-breaker
- earthing sliding contact (for withdrawable version)
- shutters for fixed part
- complete pole
- operating mechanism
- connection cables for trip units and current sensors
- transparent protective cover for trip units
- SACE PR030/B power supply unit
- toolbox
- battery for SACE PR030/B power supply unit
- front escutcheon plate for Ronis key lock

For further details, please request a copy of the ABB SACE spare parts catalogue.

Retrofitting Kits

Special kits have been prepared to replace old SACE Otomax and SACE Novomax G30 circuit-breakers. The kits include SACE Emax circuit-breakers that take advantage of all the components of the existing switchgear. Installing a new circuit-breaker in old switchgear, offers definite technical and economic benefits, and is extremely rapid as there is no need to redo the main switchgear connections.

Emmax





Applications of the circuit-breaker

Contents

Primary and secondary distribution

Selective protection 6/2

Back-up protection 6/13

Directional protection 6/14

Earth fault protection 6/20

Switching and protection of transformers 6/26

Line protection 6/30

Switching and protection of generators 6/32

Switching and protection of asynchronous motors 6/35

Switching and protection of capacitors 6/41



Primary and secondary distribution

Selective protection

Selectivity is normally actuated for tripping overcurrent protection devices in civil and industrial installations to isolate the part affected by a fault from the system, causing only the circuit-breaker immediately on the supply side of the fault to trip. The example in the figure highlights the need to coordinate tripping between the two circuit-breakers A and B so that only circuit-breaker B is tripped in the event of a fault in C, ensuring continuity of service for the rest of the system supplied by circuit-breaker A.

Whereas natural selectivity within the overload current range is normally found due to the difference between the rated currents of the load protection circuit-breaker and the main circuit-breaker on the supply side, selectivity can be obtained in the short-circuit current range by differentiating the current values and, if necessary, the trip times.

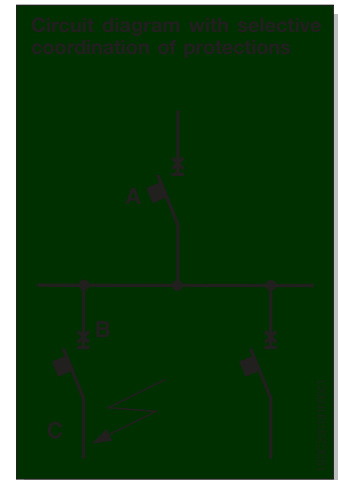

Selectivity can be total or partial:

- total selectivity: only circuit-breaker B opens for all current values lesser than or equal to the maximum short-circuit current in C;
- partial selectivity: only circuit-breaker B opens for fault currents below a certain value; A and B are both tripped for greater or equal values.

In principle, the following types of selectivity are possible:

Current selectivity, obtained by setting the instantaneous trip currents of the circuit-breaker chain to different values (higher settings for the circuit-breakers on the supply side). This often results in partial selectivity.

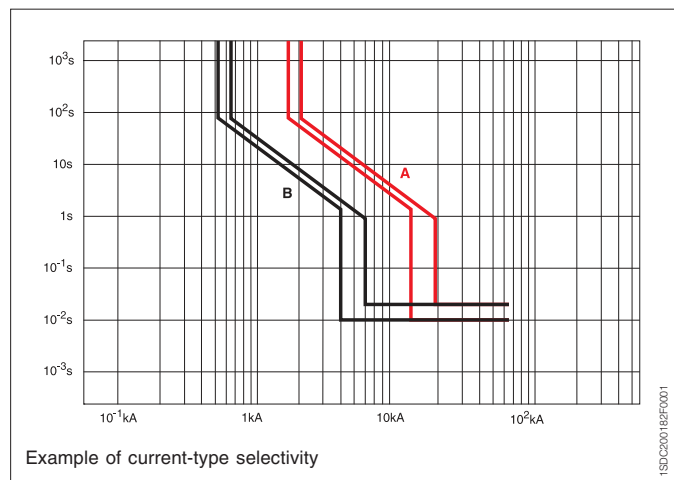

Example of current-type selectivity

Time selectivity, obtained by intentionally incorporating increasing time-delays in the trip times of the circuit-breakers furthest to the supply side in the chain.

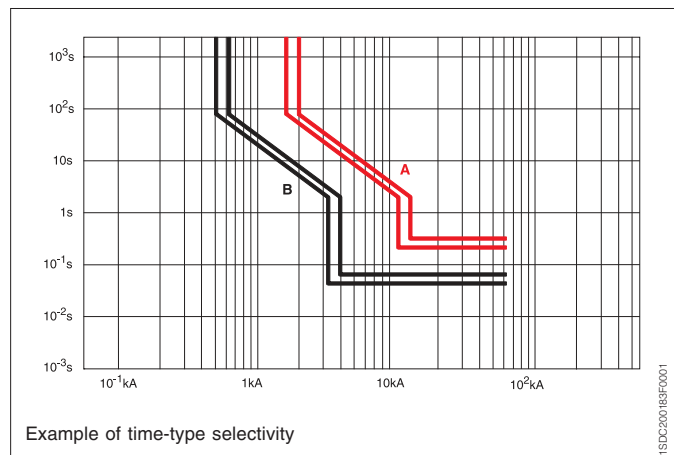

Example of time-type selectivity

To guarantee selectivity for Emax circuit-breakers, equipped with electronic PR121, PR122 and PR123 type trip units, the following conditions must be verified:

- that there is no intersection between the time-current curves of the two circuit-breakers, tolerances included
- the minimum difference between the trip time t_2 of the circuit-breaker on the supply side and the time t_2 of the circuit-breaker on the load side, whenever it is an Emax circuit-breaker, must be:
 - t_2 supply side $>$ t_2 load side + 100 ms* t = cost
 - t_2 supply side $>$ t_2 load side + 100 ms $i^2t = \text{cost}$ (<400 ms)
 - t_2 supply side $>$ t_2 load side + 200 ms $i^2t = \text{cost}$ (>400 ms)

* in auxiliary power supply or in self-supply at full power, it is reduced to 70ms.

When the above conditions are met:

- if function I is active ($I_3=\text{on}$), the maximum short-circuit current guaranteeing selectivity is equal to the setting value I_3 (minus the tolerances)
- if function I is disabled ($I_3=\text{off}$), the maximum short-circuit current for which selectivity is guaranteed must be equal to:
 - the value indicated in the table on page 6/12, if the circuit-breaker on the load side is a moulded-case circuit-breaker (MCCB)
 - the minimum value between the I_{cw} of the circuit-breaker on the supply side and the I_{cu} of the circuit-breaker on the load side, when both the circuit-breakers are Emax type.



Primary and secondary distribution

Selective protection

Here is an example of total selectivity between three Emax circuit-breakers in series in a system with 415 V rated voltage and 70 kA prospective short-circuit current.

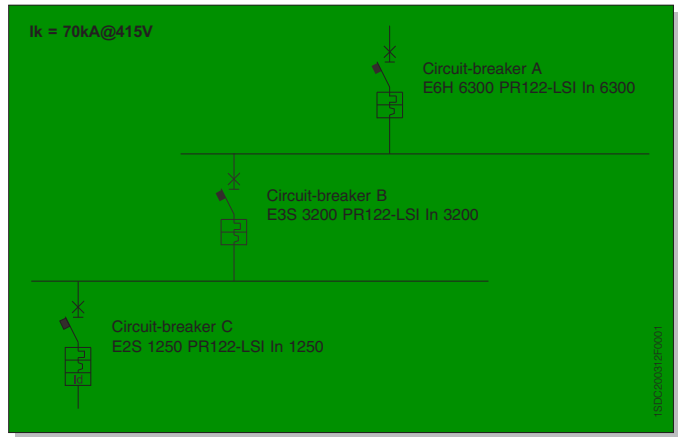

Circuit-breakers				L		S (t=cost)		I
Name	Type	Icu@415V	Icw	I1	I1'	I2	I2'	I3
A	E6H 63	100 kA	100 kA	1	108	10	0,25	off
B	E3S 32	75 kA	75 kA	1	108	10	0,15	off
C	E2S 12	85 kA	65 kA	1	108	10	0,05	off

As shown in the figure below, with the above-mentioned setting there is no intersection between the time-current curves of the different circuit-breakers and the minimum delay of 70 ms defined for the trip thresholds of protection S. Furthermore, exclusion of protection I (I₃=off) guarantees selectivity as follows:

- up to 75 kA between A and B
- up to 75 kA between B and C.

So, since the maximum prospective short-circuit current of the system is 70 kA, it is possible to talk of total selectivity.

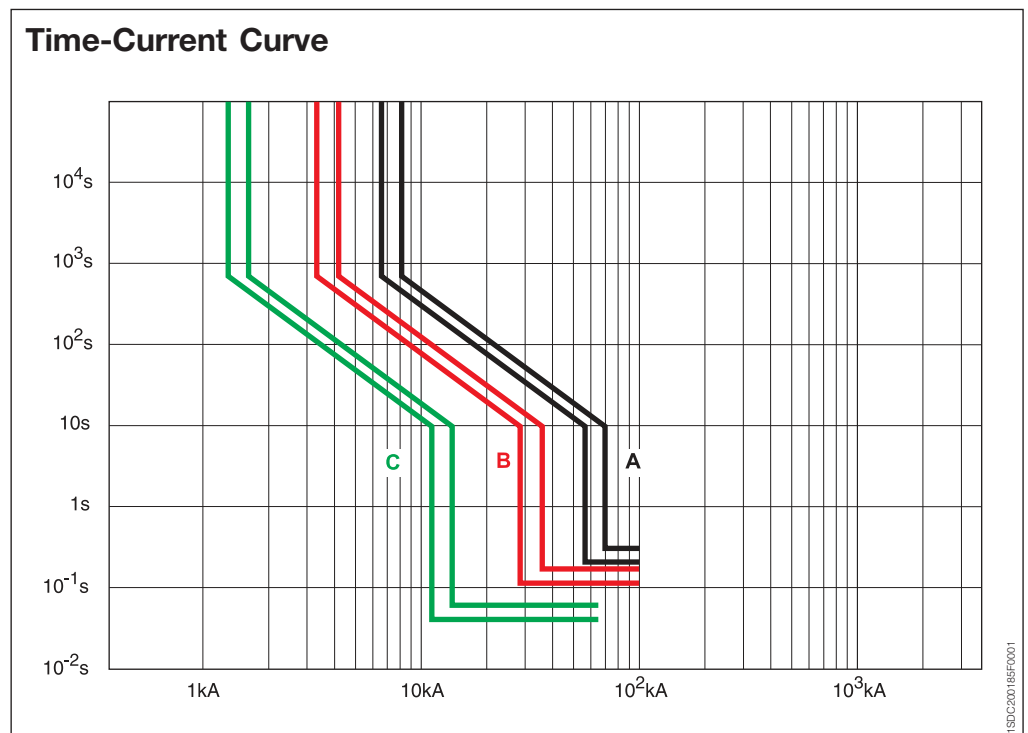

6

Double S

Thanks to the new PR123 trip unit, which allows two thresholds of protection function S to be set independently and be activated simultaneously, selectivity can also be achieved under highly critical conditions.

Here is an example of how, by using the new trip unit, it is possible to obtain a better selectivity level compared with the use of a trip unit without “double S”.

This is the wiring diagram of the system under examination; in particular, attention must be focussed on:

- the presence, on the supply side, of a MV circuit-breaker, which, for selectivity reasons, imposes low setting values for the Emax circuit-breaker on the LV side
- the presence of a MV/LV transformer which, due to the inrush currents, imposes high setting values for the circuit-breakers on its primary side.

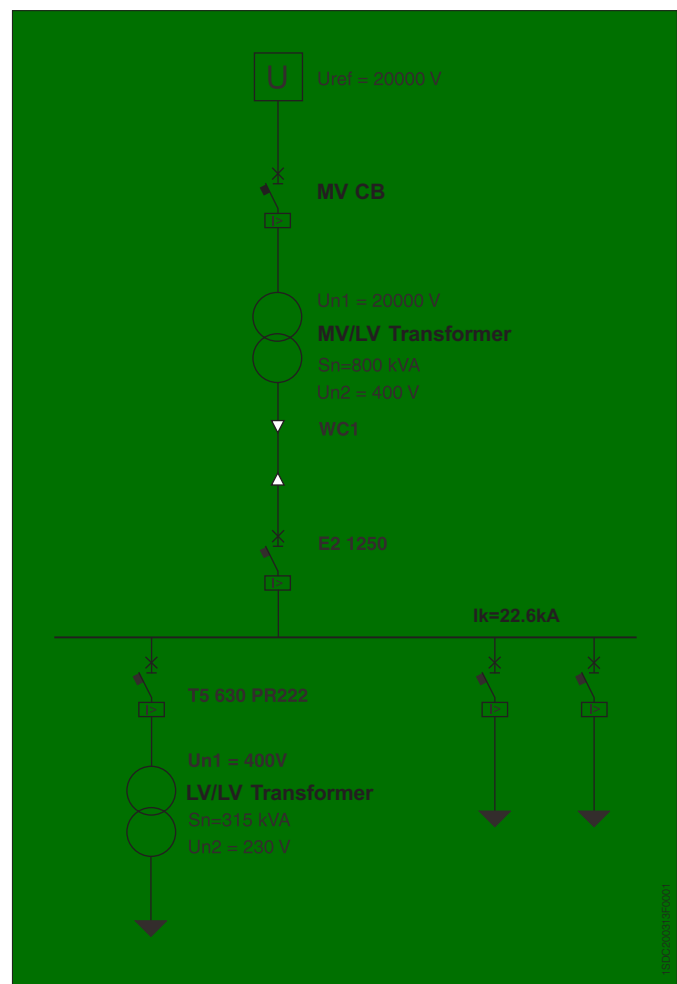



Primary and secondary distribution

Selective protection

Solution with a trip unit without “double S”

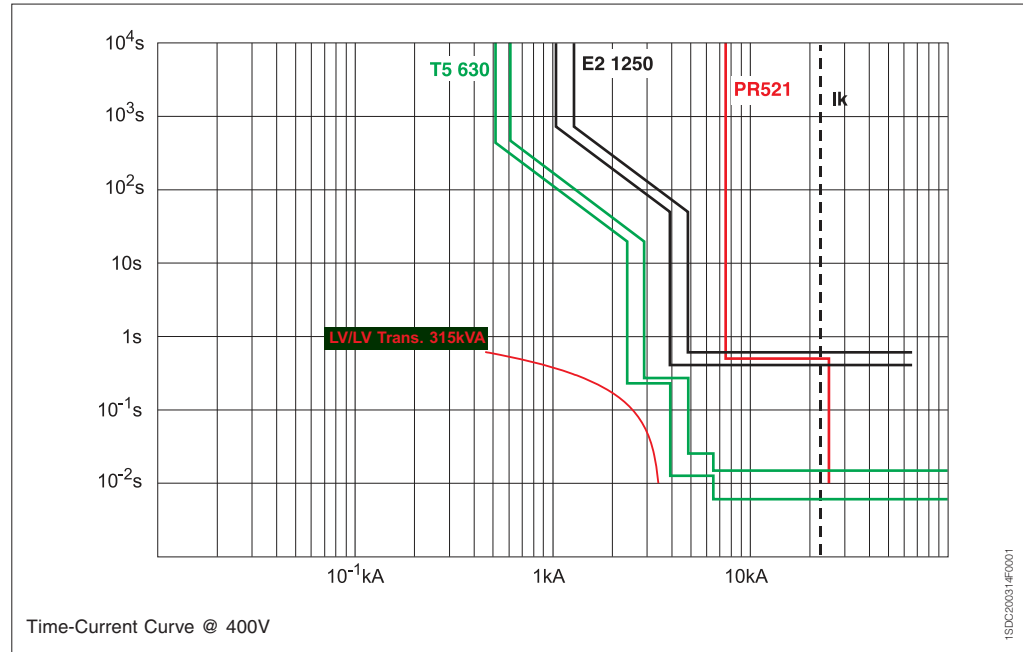

MV CB (PR521)

I_{n1} (I_n): 500 A t=0s
 51 (I_{>>}): 500 A t=0s

	E2N 1250 PR122 LSIG R1250	T5V 630 PR222DS/P LSIG R630
Setting	0.3	0.24
Curve	108s	12s
Setting	0.5	0.25
Curve	0.5s	0.25s
Setting	0.5	0.25

In the case of a short-circuit, the Emax E2 circuit-breaker and the MV circuit-breaker will open simultaneously with this solution. Attention must be paid to the fact that, owing to the value I_k , function I of the E2 circuit-breaker has to be disabled ($I_3=OFF$) so that selectivity with the T5 on the load side is granted.

Solution with the PR123 trip unit with “double S”

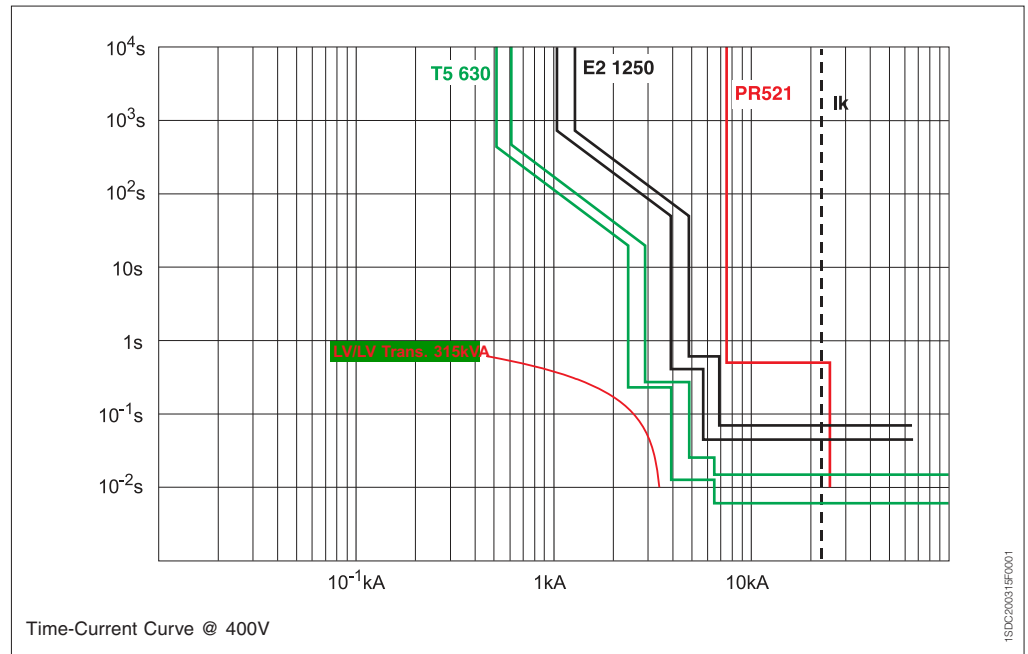

MV CB (PR521)

I_{cs} (I_{cs}): 50 A t=0.5s
 I_{cs} (I_{>>}): 500 A t=0s

	E2N 1250 PR123 LSIG R1250	T5V 630 PR222DS/P LSIG R630
Setting	0.5	0.25
Curve	108s	12s
Instant. Setting	5	5
Curve	-	0.25s
Instant. Setting	0.5	-
Curve	0.5s	-
Instant. Setting	0.05	-
Curve	0.05s	-
Setting	0.05	0.05

As is evident, by means of the “double S” function, selectivity can be achieved both with the T5 circuit-breaker on the load side as well as with the MV circuit-breaker on the supply side. A further advantage obtained by using the “double S” function is the reduction in the time of permanence of high current values under short-circuit conditions, which results in lower thermal and dynamic stresses on the busbars and on the other installation components.



Primary and secondary distribution

Selective protection

Dual Setting

Thanks to the new PR123 trip unit, it is also possible to program two different sets of parameters and, through an external command, to switch from one set to the other.

This function is useful when there is an emergency source (generator) in the system, only supplying voltage in the case of a power loss on the network side.

In the system described below, in the case of a loss of the normal supply on the network side, by means of the ABB SACE ATS010 automatic transfer switch, it is possible to switch the supply from the network to the emergency power unit and to disconnect the non-primary loads by opening the QS1 switch-disconnector.

Under normal service conditions of the installation, the circuit-breakers C are set in order to be selective with both circuit-breaker A, on the supply side, as well as with circuit-breakers D on the load side. By switching from the network to the emergency power unit, circuit-breaker B becomes the reference circuit-breaker on the supply side of circuit-breakers C. This circuit-breaker, being the protection of a generator, must be set to trip times shorter than A and therefore the setting values of the circuit-breakers on the load side might not guarantee the selectivity with B.

By means of the “dual setting” function of the PR123 trip unit, it is possible to switch circuit-breakers C from a parameter set which guarantees selectivity with A, to another set which make them selective with B. However, these new settings could make the combination between circuit-breakers C and the circuit-breakers on the load side non-selective.

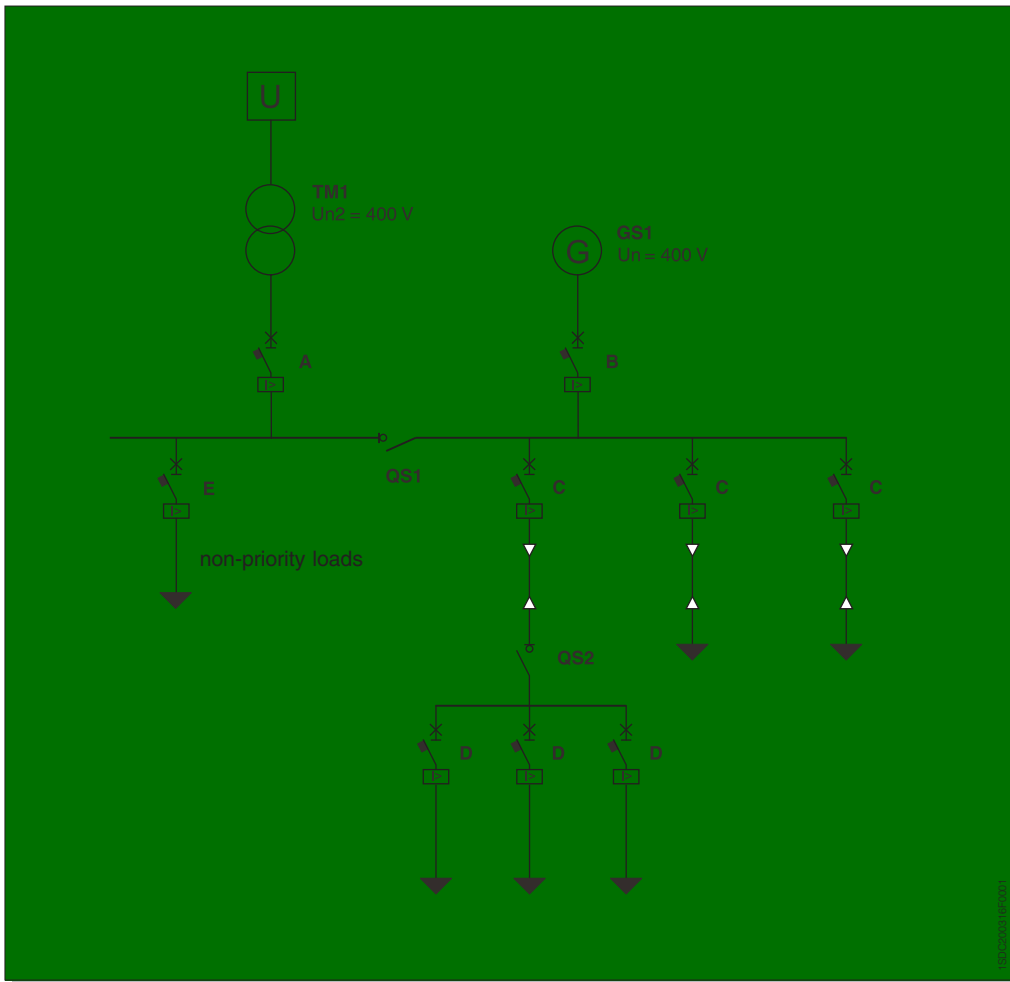

The figure at the side shows the time-current curves of the installation under normal service conditions. The values set allow no intersection of the curves.

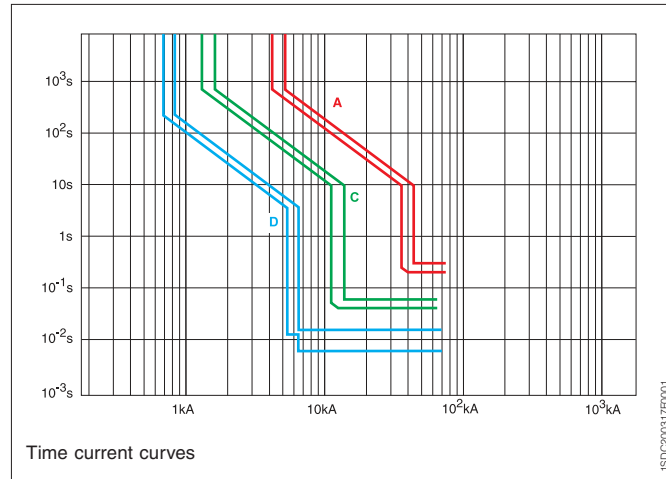

The figure at the side shows the situation in which, after switching, the power is supplied by the power unit through circuit-breaker B. If the settings of circuit-breakers C are not modified, there will be no selectivity with the main circuit-breaker B.

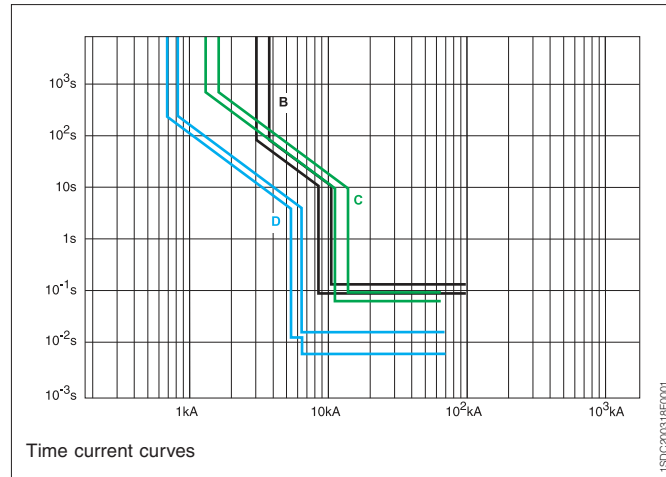

This last figure shows how it is possible to switch to a set of parameters which guarantees selectivity of circuit-breakers C with B by means of the “dual setting” function.

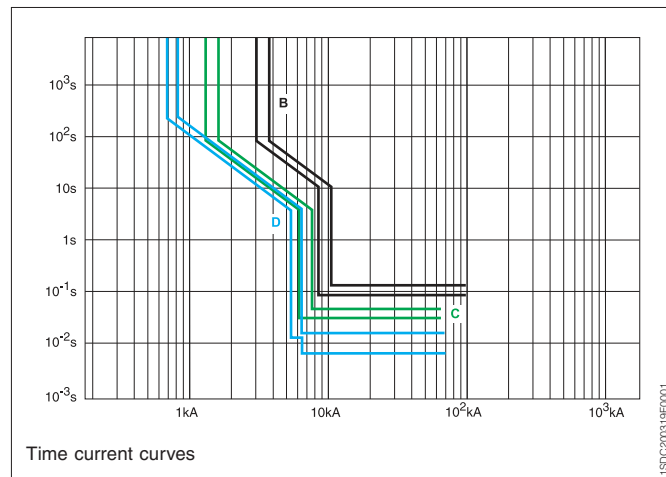



Primary and secondary distribution

Selective protection

Zone selectivity

The **zone selectivity**, which is applicable to protection functions S and G, can be enabled in the case where the curve with fixed time is selected and the auxiliary power supply is present. This type of selectivity allows shorter trip times for the circuit-breaker closest to the fault than in the case of time-selectivity. It is a type of selectivity suitable for radial nets.

The word zone is used to refer to the part of an installation between two circuit-breakers in series. The fault zone is the zone immediately on the load side of the circuit-breaker that detects the fault. Each circuit-breaker that detects a fault communicates this to the circuit-breaker on the supply side by using a simple communication wire. The circuit-breaker that does not receive any communication from those on the load side will launch the opening command within the set selectivity time (40÷200ms).

We have to consider that the circuit-breakers receiving a signal from another trip unit will operate according to the set time t_2 .

If, for any reason, after the selectivity time, the circuit-breaker due to trip has not opened yet, it lets the "block signal" fall on the other circuit-breaker, which will trip.

To realize correctly the zone selectivity the following settings are suggested:

	I3 = selectivity time = 1.0 seconds
I	I3 = OFF
Selectivity time	same setting for each circuit-breaker

* Trip duration for $I < I_{cw}$ (max) = 70 ms.

To carry out the cabling, a shielded twisted pair cable (not supplied; ask ABB for information) can be used. The shield should only be earthed on the trip unit of the circuit-breaker on the supply side.

The maximum length of the cabling for zone selectivity, between two units, is 300 meters.

The maximum number of the circuit-breakers which can be connected to the outputs (Z out) of a trip unit is 20.

All Emax circuit-breakers in versions B-N-S-H-V fitted with PR122 and PR123 trip units allow zone selectivity to be realised.

Note

With regard to selectivity in the case of earth faults with circuit-breakers in series, see page 6/20.

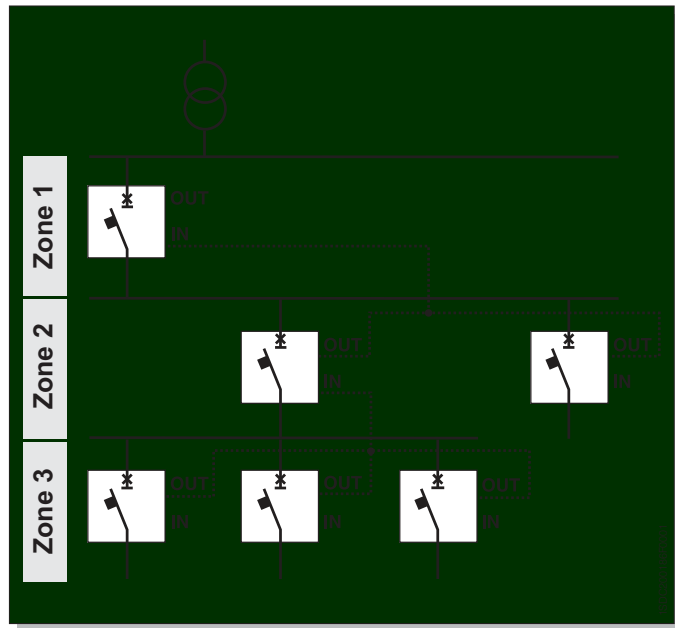



Primary and secondary distribution

Selective protection

Selectivity tables

Emax air circuit-breakers with moulded-case circuit-breakers

				Supply-side		E1		E2				E3				E4				E6	
				Version		B	N	B	N	S	L*	N	S	H	V	L*	S	H	V	H	V
				Trip unit		EL		EL				EL				EL				EL	
Load-side	Version	Trip unit	Size [A]	800	800	1600	1000	800	1250	2500	1000	800	800	2000	4000	3200	3200	4000	3200	4000	3200
				1000	1000	2000	1250	1000	1600	3200	1250	1000	1250	3500				4000	4000	5000	4000
				1250	1250		1600	1250			1600	1250	1600							6300	5000
				1600	1600		2000	1600			2000	1600	2000								6300
								2000					2500	2000	2500						
													3200	2500	3200						
													3200								
T1	B	TM	160	T	T	T	T	T	T	T	T	T	T	T	T	T	T	T	T	T	T
	C			T	T	T	T	T	T	T	T	T	T	T	T	T	T	T	T	T	T
	N			T	T	T	T	T	T	T	T	T	T	T	T	T	T	T	T	T	T
T2	N	TM, EL	160	36	T	T	T	T	T	T	T	T	T	T	T	T	T	T	T	T	T
	S			36	T	T	55	65	T	T	T	T	T	T	T	T	T	T	T	T	T
	H			36	T	T	55	65	T	T	T	T	75	T	T	T	T	T	T	T	T
	L			36	T	T	55	65	T	T	T	T	75	T	T	T	T	T	T	T	T
T3	N	TM	250	T	T	T	T	T	T	T	T	T	T	T	T	T	T	T	T	T	T
	S			36	T	T	T	T	T	T	T	T	T	T	T	T	T	T	T	T	T
T4	N	TM, EL	250	36	T	T	T	T	T	T	T	T	T	T	T	T	T	T	T	T	T
	S		320	36	T	T	55	65	T	T	T	T	T	T	T	T	T	T	T	T	T
	H			36	T	T	55	65	100	T	T	T	75	85	100	T	T	100	T	100	T
	L			36	T	T	55	65	100	T	T	T	75	85	100	T	T	100	T	100	T
	V			36	T	T	55	65	100	T	T	T	75	85	100	T	T	100	T	100	T
T5	N	TM, EL	400	T	T	T	T	T	T	T	T	T	T	T	T	T	T	T	T	T	T
	S		630	36	T	T	T	T	T	T	T	T	T	T	T	T	T	T	T	T	T
	H			36	T	T	55	65	T	T	T	T	T	T	T	T	T	T	T	T	T
	L			36	T	T	55	65	100	T	T	T	75	85	100	T	T	100	T	100	T
	V			36	T	T	55	65	100	T	T	T	75	85	100	T	T	100	T	100	T
S6	N	TM, EL	800	T	T	T	T	T	T	T	T	T	T	T	T	T	T	T	T	T	T
	S			36	T	T	T	T	T	T	T	T	T	T	T	T	T	T	T	T	T
	H			36	T	T	55	65	T	T	T	T	T	T	T	T	T	T	T	T	T
	L			36	T	T	55	65	T	T	T	T	75	85	T	T	T	T	T	T	T
S7	S	EL	1250	-	-	T	T	T	-	T	T	T	T	T	T	T	T	T	T	T	T
	H		1600	-	-	T	55	T	-	T	T	T	T	T	T	T	T	T	T	T	T
	L			-	-	T	55	65	-	T	T	T	75	85	T	T	T	T	T	T	T

6

General prescriptions:

- Function I of the electronic PR121, PR122 and PR123 trip units of the supply-side circuit-breakers must be excluded (I_3 in OFF).
- Selectivity is expressed in kA at the supply voltage of 380-415 V AC in accordance with IEC 60947-2 Standards.
- T = total selectivity (the selectivity value is the lowest one between the breaking capacities (Icu) of both the circuit-breaker on the load-side as well of the circuit-breaker on the supply side)
- It is of fundamental importance to verify that the settings chosen by the user for the trip units placed both on the supply as well as on the load side do not result in intersections of the time-current curves for protection against overload (function L) and for protection against short-circuit with time-delayed trip (function S).

* Emax L circuit-breakers with PR122/P and PR123/P trip units only.



Primary and secondary distribution

Back-up protection

Back-up protection is required by the IEC 60364-4-43 Standards and Annex A of the IEC 60947-2 Standard, which allow the use of a protection device with breaking capacity lower than the prospective short-circuit current at the points where it is installed, provided that there is another protection device on the supply side with the necessary breaking capacity. In this case, the characteristics of the two devices must be coordinated in such a way that the specific energy let through by the combination is not higher than that which can be withstood without damage by the device on the load side, and by the protected conductors. In the diagram in the figure, circuit-breaker B, located on the load side of circuit-breaker A, can have a lower breaking capacity than the prospective short-circuit current in the event of a fault in "C", if circuit-breaker A is able to satisfy both of the following conditions:

- it has a suitable breaking capacity (higher than or equal to the prospective short-circuit current at its point of installation and obviously higher than the short-circuit current in "C")
- in the event of a fault in "C" with short-circuit values higher than the breaking capacity of circuit-breaker B, circuit-breaker A must provide a specific let-through energy limiting function, limiting it to a value that can be withstood by circuit-breaker B and by the protected conductors.

A fault in "C" can therefore cause a double interruption, however the back-up protection must ensure that B always trips within the limits of its breaking capacity.

It is necessary to choose switchgear combinations that have been verified by laboratory tests for this type of protection. The possible combinations are specified in ABB SACE documents and PC programs (Slide rule kits, DOCWin, etc.) and shown here for SACE Emax circuit-breakers.

Back-up protection is used in electrical installations in which there is no essential need for continuous operation: when the supply-side circuit-breaker opens, it also excludes loads that are not affected by the fault. Furthermore, the use of this type of coordination limits the size of the installation and consequently reduces costs.

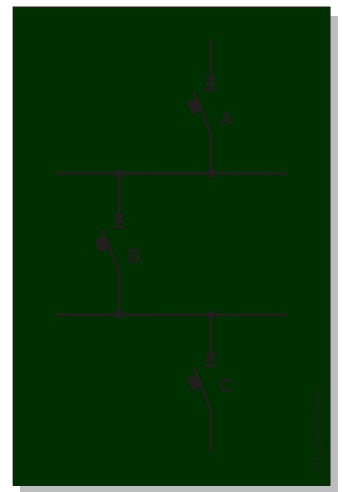
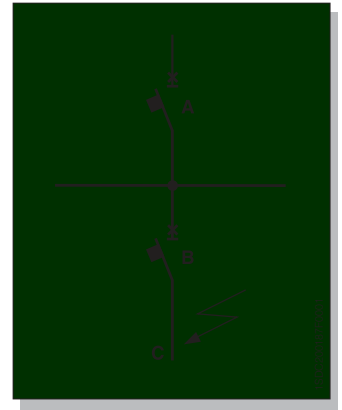

Note

Back-up protection can also be implemented on more than two levels: the figure above shows an example of coordination on three levels. In this case, the choices are correct if at least one of the two situations below is satisfied:

- the circuit-breaker furthest on the supply side A is coordinated with both circuit-breakers B and C (coordination between circuit-breakers B and C is not necessary);
- each circuit-breaker is coordinated with the circuit-breaker immediately to the load side of it, i.e. the circuit-breaker furthest to the supply side A is coordinated with the next one B, which is in turn coordinated with circuit-breaker C.

Table showing coordination for back-up protection

Supply-side circuit-breaker	Breaking capacity
T4S - T5N - S6N - E1B - E2B	85 [kA]
Load-side circuit-breaker	Back-up value
T4L	65 [kA]
T4S - T5N - S6N - E1B - E2B	85 [kA]
T4L - T5L	130 [kA]



Directional protection

Directional protection is based on the ability to correlate the circuit-breaker's behavior with the direction of the fault current.

Two different trip times can be set on the PR123 trip unit depending on the current direction:

- a time ($t7Fw$) for a direction of current concordant (Fw) with the reference direction set;
- a time ($t7Bw$) for a direction of current discordant (Bw) with the reference direction set.

A current threshold only (I7) can be set on the PR123 trip unit.

If the fault current is discordant (Bw) with the reference direction, the protection shall intervene when the threshold I7 is reached within the set time $t7Bw$ (provided that the functions S and I have not been set as to intervene before function D).

If the fault current is concordant (Fw) with the reference direction, the protection shall intervene when the threshold I7 is reached within the set time $t7Fw$ (provided that the functions S and I have not been set as to intervene before function D).

Moreover, if function I is active and the short-circuit current exceeds the set value I_3 , the circuit-breaker will trip instantaneously independently of the direction of the current.

The reference direction set by ABB is from the top of the circuit-breaker (the zone where the trip unit is located) towards the bottom.

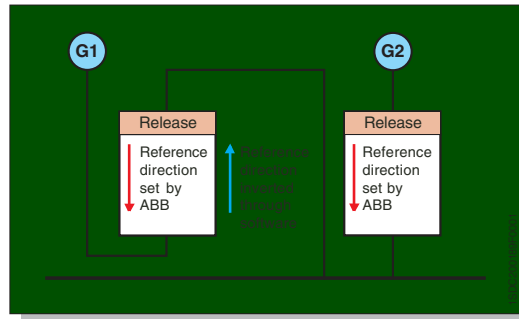

The figure above shows the actual configuration the circuit-breakers have in the system. The red arrow shows the reference direction set by default on the circuit-breaker.

If the power supply direction of the circuit-breaker is from top to bottom (supply from G2), the reference direction must remain the one set by ABB.

If the power supply direction of the circuit-breaker is from bottom to top (supply from G1), the new PR123 trip unit allows the default setting to be inverted by operating on its software.

In this way, all the quantities measured by the PR123 trip unit can be evaluated as they actually flow through the installation. Furthermore, in the wiring diagram of the system, the reference

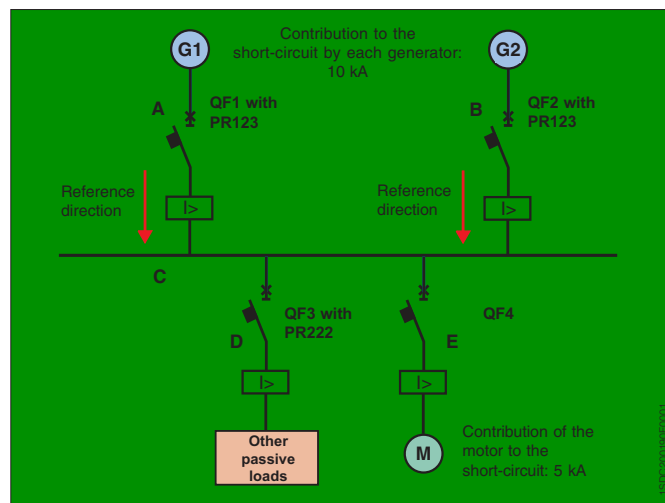

direction to carry out a selectivity study and consider the tripping directions Bw or Fw correctly still remains from top to bottom.

In the following wiring diagram the reference directions are shown in red. By considering the circuit-breakers supplied as in the figure above, it can be seen that for QF2 this is the default direction, whereas for QF1 the direction has been inverted by means of the software.

By assuming some numerical values for the short-circuit currents, and considering some fault points, the following is the result.

For circuit breaker QF1, if a fault occurs at point B, the current will flow in direction A-B concordant to the reference direction or similarly, for a fault in A, the current direction will be B-A in discordance with the reference direction.

The different configurations can be resumed in the following table:

Circuit-breaker	Location of fault	Measured current [kA]	Direction	Tripping time
QF1	A	15	Discordant	t7Bw
	B, C, D, E	10	Concordant	t7Fw
QF2	B	15	Discordant	t7Bw
	A, C, D, E	10	Concordant	t7Fw

This installation aims at selectivity between QF1, QF2, QF3 and QF4.

On examining the table, we see that the only instance in which the fault current direction is discordant with that set for the circuit-breaker QF1 occurs in case of a fault in point A. The circuit-breaker QF1 must trip more quickly than the other circuit-breakers, since it is the one nearest to the fault. To this purpose, the trip time t7Bw of QF1 must be set at:

- a value below the time t7Fw of the circuit-breaker QF2, since the fault current is concordant with QF2 reference direction
- a value lower than the time “t2” of protection “S”, if available, for the trip unit of the moulded-case circuit-breaker QF4. The instantaneous protection of QF4 shall be set in OFF or shall have a setting value I3 higher of the contribution given by the motor to the short-circuit current.

Moreover, the functions S and I of both QF1 and QF2 have been set so as not to intervene before function D.

Similarly to the process described for circuit-breaker QF1, to ensure selectivity, circuit-breaker QF2 must trip first in the case of a fault in B, and then with a delayed trip in the case of faults anywhere else in the system.

The settings available for directional protection D, both for Fw and Bw, are the following:

t _r =0.20s...0.8s	(tolerance ± 20%)	step 0.01s
------------------------------	-------------------	------------



Directional protection

Zone selectivity D (Directional Zone Selectivity)

Thanks to this function, it is also possible to obtain selectivity in meshed and ring networks. By means of zone selectivity with function D "Zone selectivity D", which can only be set to [On] when zone selectivity "S" and "G" are set to [Off] and there is an auxiliary power supply, it is possible to coordinate the behaviour of the various PR123 devices, by cabling the trip unit buses in a suitable way.

In fact, each trip unit has 4 signals available:

- two input signals (one in a concordant and one in a discordant direction) by means of which the trip unit receives the "block" signal from other trip units
- two output signals (one in a concordant and one in a discordant direction) by means of which the trip unit sends a "block" signal to other trip units.

The circuit-breakers which do not receive a "block" signal (coordinated in the direction of the current) will send the opening command within a time equal to " t_{7sel} ".

The circuit-breakers which receive the "block" signal will open within the backward or forward time according to the direction of the current.

If function I is activated and the short-circuit current exceeds the set value (I_3), the circuit-breaker will open instantaneously and independently of the directions and of the signals received.

For safety reasons, the maximum duration of the "block" signal is 200ms.

If, after this time and for any reason, the circuit-breakers due to trip have not yet opened, the "block" signal falls on the other circuit-breakers which will command immediate opening. This operation therefore occurs after a maximum time of 200ms.

A shielded twisted pair cable (not supplied; ask ABB for information) can be used to carry out the cabling. The shield should only be earthed on the trip unit of the circuit-breaker on the supply side.

- The maximum length of the cabling for zone direction selectivity, between two units, is 300 metres.
- A maximum number of 20 circuit-breakers can be connected to the outputs (OUT Bw or OUT Fw) of a trip unit.

The figure below shows the connections necessary to activate the "blocks" between the various trip units. In particular:

- 1) in the case of a fault in A, circuit-breaker QF1 is passed through by a current from busbar B1; this current flows in a direction discordant with the one set. The OUT Bw bus of QF1 "blocks" the IN Fw bus of circuit-breaker QF2 and the IN Bw bus of circuit-breaker QF3: in fact, the

current flows through QF2 in the same direction as the setting, whereas QF3 is passed through by a current discordant with the setting (the active "block" signals are indicated by wider arrows).

6

Direction (OUT-IN)	Arrow
Bw Q#Bw	
Bw Q#Fw	
Fw Q#Fw	

Reference Direction

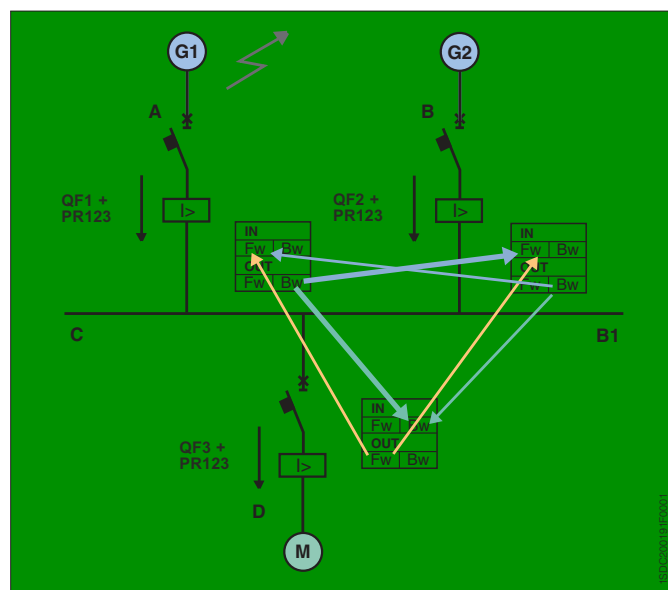

2) in the case of a fault in B, circuit-breaker QF2 is passed through by a current from busbar B1; this current flows in a direction discordant with the one set. The OUT Bw bus of QF2 "blocks" the IN Fw bus of circuit-breaker QF1 and the IN Bw bus of circuit-breaker QF3: in fact, the

current flows through QF1 in the same direction as the setting, whereas QF3 is passed through by a current discordant with the setting (the active "block" signals are indicated by wider arrows).

Direction (OUT-IN)	Arrow
Bw OUT Bw	
Bw OUT Fw	
Fw OUT Fw	

Reference Direction

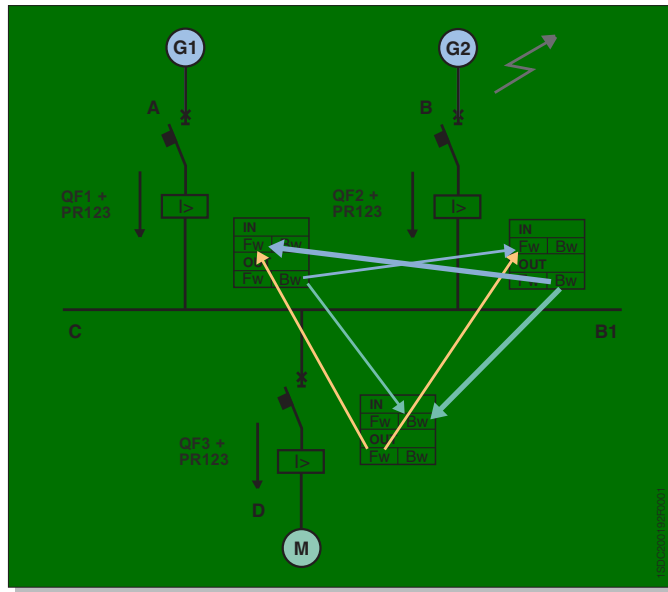

3) in case of a fault in C, circuit-breakers QF1 and QF2 are passed through by a current flowing in the same direction as the one set, whereas QF3 is passed through by a current with discordant direction. No circuit-breaker is "blocked" and consequently all the circuit-breakers affected by the fault will trip according to the time settings of protections "S" and/or "I".

No circuit-breaker is "blocked" and consequently all the circuit-breakers affected by the fault will trip according to the time settings of protections "S" and/or "I".

Direction (OUT-IN)	Arrow
Bw OUT Bw	
Bw OUT Fw	
Fw OUT Fw	

Reference Direction

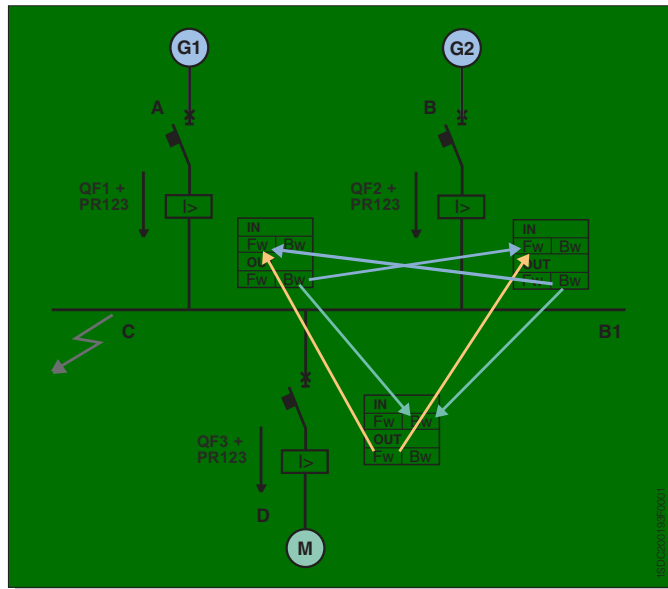



Directional protection

4) in the case of a fault in D, circuit-breaker QF3 is passed through by a current from busbar B1; this current flows in the same direction as the one set. The OUT Fw bus of QF3 "blocks" the IN Fw bus of circuit-breakers QF1 and QF2: in fact, both circuit-breakers are passed through by fault currents concordant with the direction set (the active "block" signals are indicated by wider arrows).

Direction (OUT-IN)	Arrow
Bw → QinBw	
Bw → QinFw	
Fw → QinFw	

Reference Direction

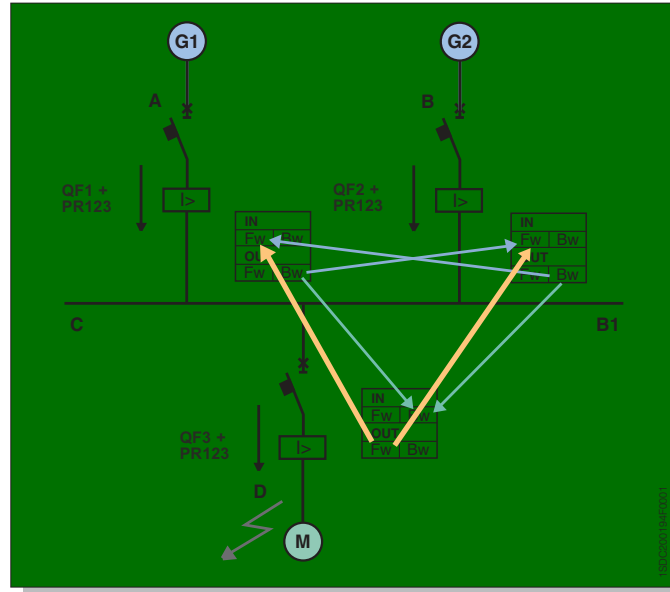

Fw bus of circuit-breakers QF1 and QF2: in fact, both circuit-breakers are passed through by fault currents concordant with the direction set (the active "block" signals are indicated by wider arrows).

The following example analyses a network with a bus-tie and takes the behavior of the protection devices in the presence of faults into consideration:

1) Fault in B1 with the bus-tie closed: only circuit-breakers QF1 and QF3 must interrupt the fault: in particular, circuit-breaker QF3 is passed through by a current from busbar B2 (therefore in the same direction as the one set); the OUT Fw bus sends a "block" signal to the IN Fw bus of circuit-breaker QF2 (passed through by a current flowing from transformer TM2 and consequently in a direction concordant with the one set), and to the IN Bw bus of circuit-breaker QF5 (passed through from a current flowing from the motor and consequently in a direction discordant with the one set).

Direction (OUT-IN)	Arrow
Fw → QinFw	
Fw → QinBw	
Bw → QinFw	

Reference Direction

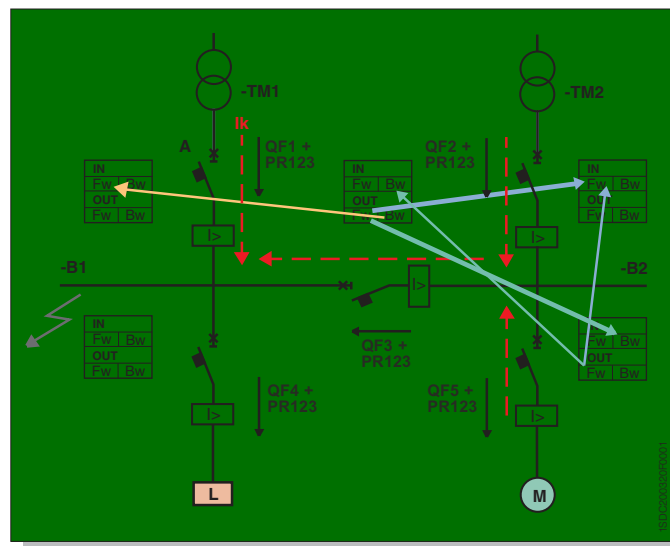

the IN Bw bus of circuit-breaker QF5 (passed through from a current flowing from the motor and consequently in a direction discordant with the one set).

6

2) Fault in the motor: in this case, only circuit-breaker QF5 must interrupt the fault. Circuit-breaker QF5 is passed through by a current flowing from busbars B1 and B2, in a direction concordant with the one set; therefore, the OUT Fw bus of QF5 “blocks” both the IN Fw bus of QF2 (passed through by a current flowing from TM2 and consequently in a direction concordant with the one set) as well as the IN Bw bus of QF3 (which is passed through by a current flowing from TM1 and consequently in a direction discordant with the one set). Similarly,

circuit-breaker QF3 is also passed through by a current flowing from TM1 in a direction discordant with the one set: consequently, the OUT Bw bus of QF3 “blocks” the IN Fw bus of QF1 (passed through by a current flowing from TM1 and therefore in a direction concordant with the setting).

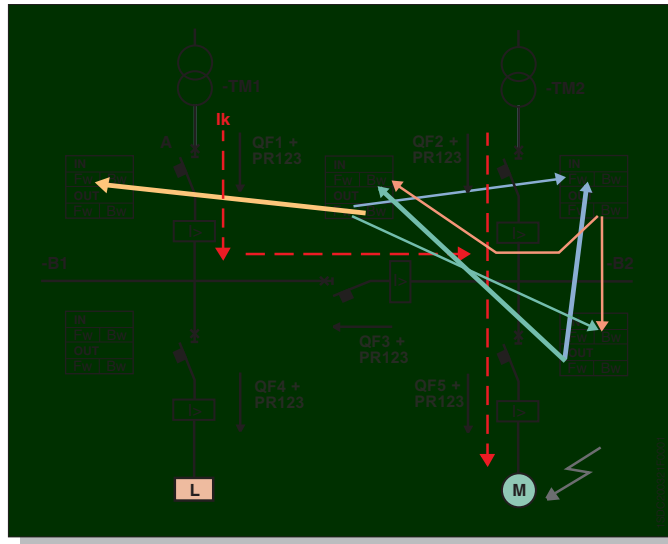
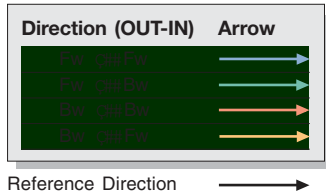

3) Fault on the supply side of transformer TM2: in this case, only circuit-breaker QF2 must interrupt the fault. Circuit-breaker QF2 is passed through by a current flowing from TM1 and from the motor, in a direction discordant with the one set; as a consequence the OUT Bw bus of QF2 “blocks”:

- the IN Bw bus of QF5 (passed through by a current flowing from the motor and consequently in a direction discordant with the one set)
- the IN Bw bus of QF3 (passed through by a current flowing from TM1 and consequently in a direction discordant with the one set).

Similarly, circuit-breaker QF3 is also passed through by a current flowing from TM1 in a direction discordant with the one set; therefore its OUT Bw bus “blocks” the IN Fw bus of QF1 (passed through by a current flowing from TM1 and therefore in a direction concordant with the setting).

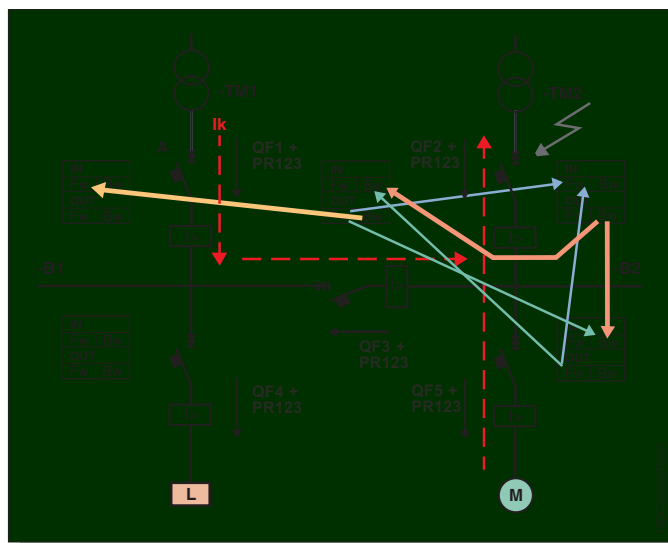
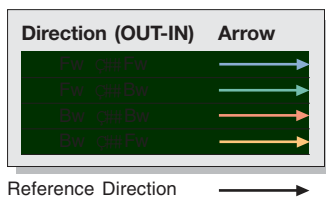



Earth fault protection

Circuit-breakers with protection G

Circuit-breakers fitted with trip units offering earth fault protection function G are usually used in MV/LV distribution substations to protect both the transformers and the distribution lines.

Protection function G calculates the vectorial sum of the currents detected by the current transformers on the phases and on the neutral conductor. In a sound circuit, this sum, which is called residual current, is equal to zero, whereas in the presence of an earth fault it has a value depending on the fault ring involved.

Function G is effectively used in TT, IT, and TN-S electrical installations and, limited to the section of the installation with a neutral conductor (N) branched and separated from the conductor PE, in TN-CS systems as well (for the TN-S area only).

Function G is not used in TN-C systems, since these provide the neutral and protection functions using a single conductor.

The protection device thresholds and trip times can be selected from a wide range, also making it easy to achieve selectivity for this type of fault with

regard to the protection devices installed on the load side. Selectivity is therefore ensured regarding the residual-current trip units located on the load side.

Function G of the PR121, PR122 and PR123 trip units is provided with specific let-through energy curves ($I^2t=k$) and with independent time-current curves ($t=k$).

The figure in the following page shows an example of one possible choice of earth fault protection devices and their possible settings.

Protection functions G of the circuit-breakers on the main switchboard A serve to enable them to trip selectively, in relation to each other and to the residual-current protection devices located on the loads of the distribution switchboard B.

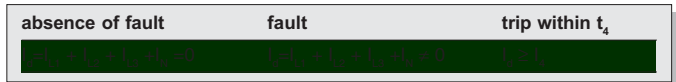
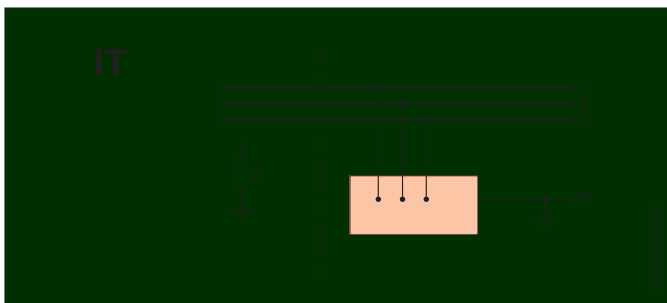
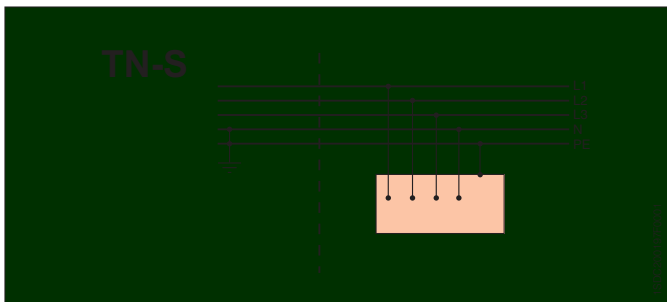
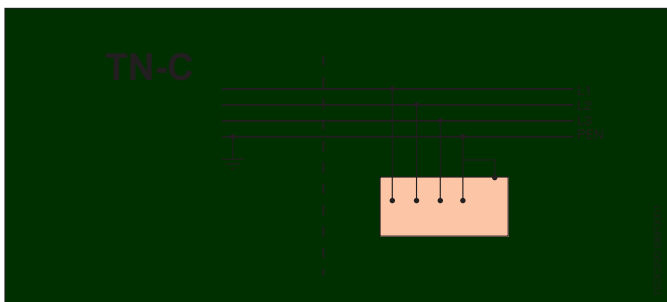
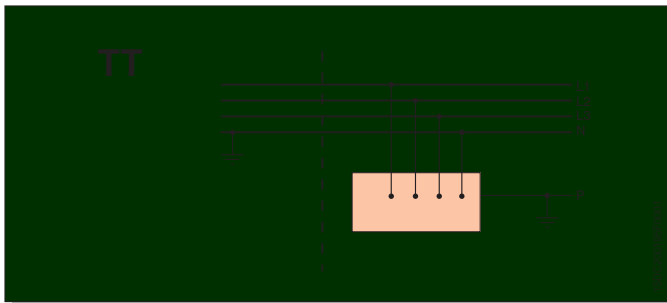

Example of selection of earth fault protection devices and their relevant settings.

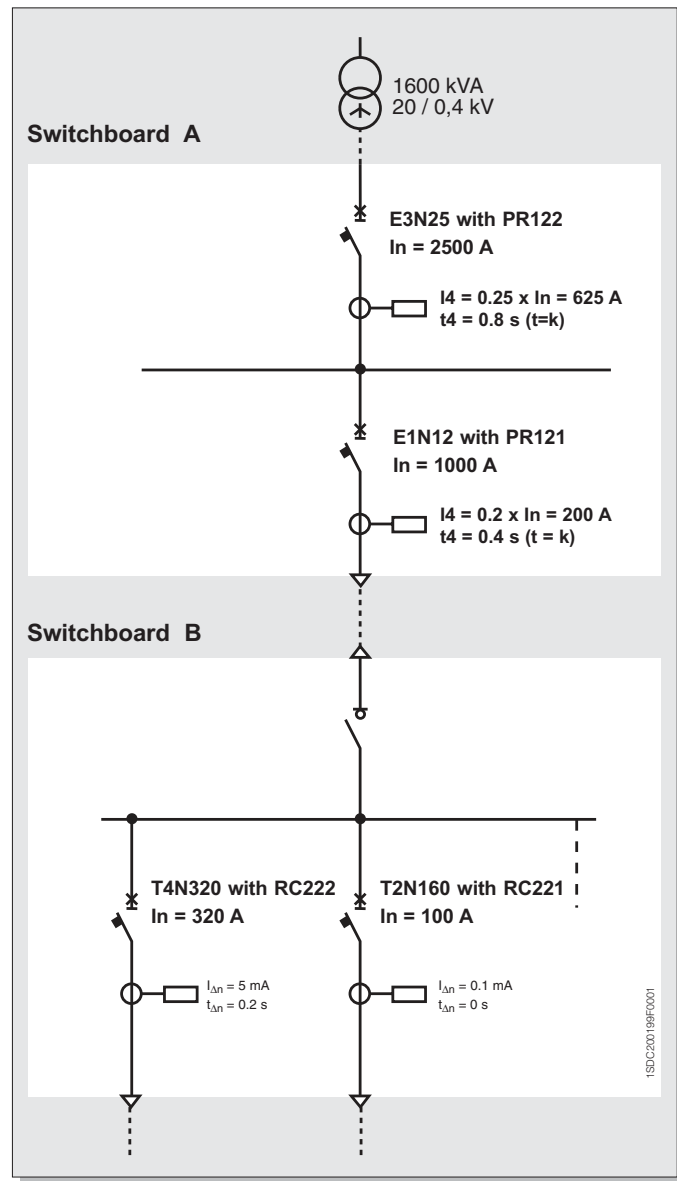



Earth fault protection

Use of the toroid on the star center of the transformer

In the case of circuit-breakers to protect MV/LV transformers, it is possible to install a toroid on the conductor connecting the star centre of the transformer to earth (application allowed with the SACE Emax series fitted with the PR122 and PR123 electronic trip units. This detects the earth fault current.

The figure beside shows the operating principle of the toroid installed on the star centre of the transformer.

The use of this accessory allows the protection threshold against earth fault (function G) to be independent of the size of the primary current transformers installed on the circuit-breaker phases. For the technical characteristics of the toroid see the table at page 6/24.

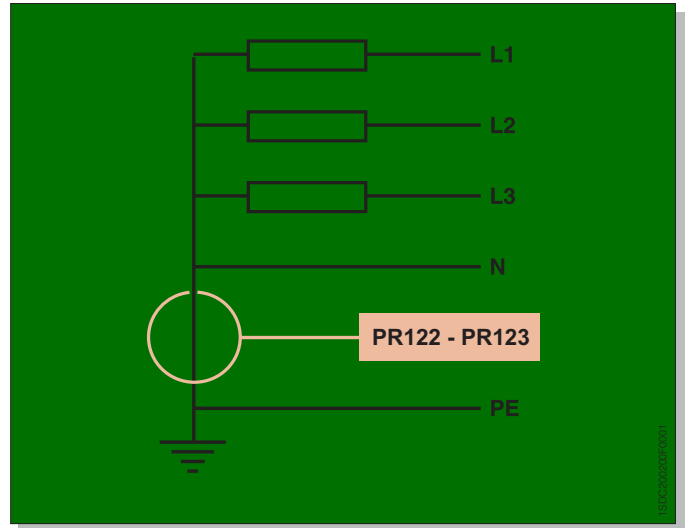

Double G

The Emax type circuit-breakers, equipped with the PR123 electronic trip unit, allow two independent curves for protection G: one for the internal protection (function G without external toroid) and one for the external protection (function G with external toroid, as described in the above paragraph).

A typical application of function double G consists in simultaneous protection both against earth fault of the secondary of the transformer and of its connection cables to the circuit-breaker terminals (restricted earth fault protection), as well as against earth faults on the load side of the circuit-breaker (outside the restricted earth fault protection).

Example

Figure 1 shows a fault on the load side of an Emax circuit-breaker: the fault current flows through one phase only and, if the vectorial sum of the currents detected by the four current transformers (CTs) is to be higher than the set threshold, the electronic trip unit activates function G (and the circuit-breaker trips).

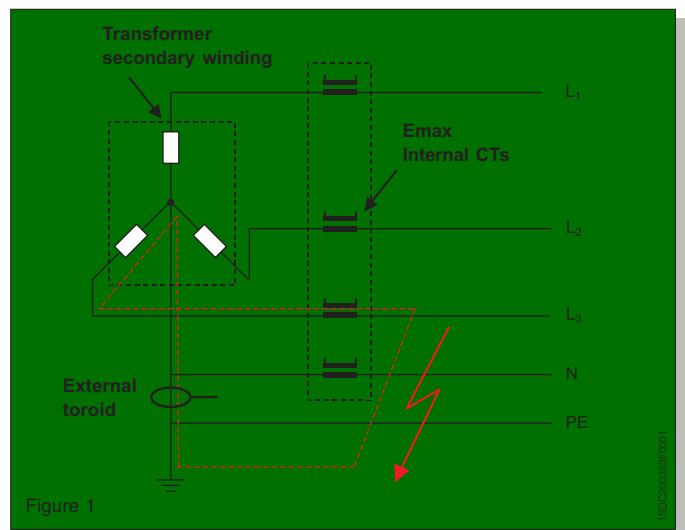

With the same configuration, a fault on the supply side of the circuit-breaker (Figure 2) does not cause intervention of function G since the fault current does not affect either the CT of the phase or that of the neutral.

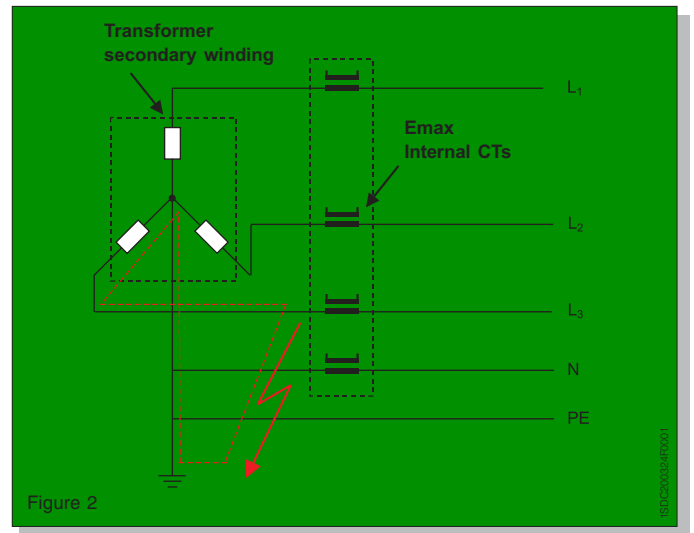

The use of function “double G” allows installation of an external toroid, as shown in Figure 3, so that earth faults on the supply side of Emax CB can be detected as well. In this case, the alarm contact of the second G is exploited in order to trip the circuit-breaker installed on the primary and to ensure fault disconnection.

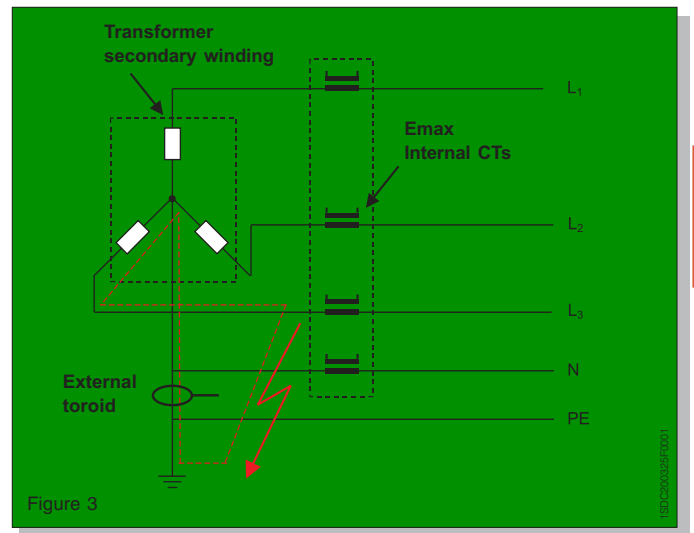



Earth fault protection

If, with the same configuration as Figure 3, the fault occurs on the load side of the Emax circuit-breaker, the fault current would affect both the toroid as well as the current transformers on the phases. To define which circuit-breaker is to trip (MV or LV circuit-breaker), suitable coordination of the trip times is required: in particular, it is necessary to set the times so that the LV circuit-breaker opening due to internal function G is faster than realization of the alarm signal coming from the external toroid. Therefore, thanks to the time-current discrimination between the two G protection functions, before the MV circuit-breaker on the primary of the transformer receives the trip command, the circuit-breaker on the LV side is able to eliminate the earth fault. Obviously, if the fault occurred on the supply side of the LV circuit-breaker, only the circuit-breaker on the MV side would trip.

The table shows the main characteristics of the range of toroids (available only in the closed version).

Characteristics of the toroid ranges

Rated current	up to 2000 A
Outer dimensions of the toroid	
	D = 400 mm W = 196 mm H = 51 mm

Residual current protection

Emax air circuit-breakers can be equipped with a toroid fitted on the back of the circuit-breaker so as to ensure protection against earth faults.

In particular, the electronic trip unit types able to perform this function are:

- PR122/P L – S – I – Rc
- PR122/P L – S – I – G - with “Measuring” module
- PR123/P L – S – I – G

which can all be provided for the following types of circuit-breakers: E1 and E2, both three and four pole versions, and E3 (three pole version).

Thanks to the wide range of settings, the above mentioned electronic trip units with the residual current function are suitable for applications where a residual current protection system coordinated with the various distribution levels is to be constructed from the main switchboards to the final load.

It is particularly suitable where low-sensitivity residual current protection is required, for example in both partial (current-type) or total (time-type) selectivity chains, and for high-sensitivity applications to protect people against indirect contact.

These electronic trip units with residual current protection are suitable for use in the presence of:

- alternating earth current (Type AC)
- alternating and/or pulsating current with continuous components (Type A)

The table below shows the main technical characteristics of the residual current protection:

Sensitivity $I_{\Delta n}$	[A] 3-5-7-10-20-30 (trip in position 1)
Tripping time	[s] 0.06-0.1-0.2-0.3-0.4-0.5-0.8
Type	AC and A

Using the SACE RCQ switchboard electronic residual current relays

The family of SACE Emax circuit-breakers with a rated current up to 2000A can be combined, if fitted with a shunt opening trip unit, with the SACE RCQ residual current relay for switchboard with a separate toroidal transformer (for installation outside on the line conductors) thereby enabling earth leakage currents to be determined for values between 0.03 and 30A.

Thanks to the wide range of settings, the SACE RCQ switchboard relay is suitable for applications where a residual current protection system coordinated with the various distribution levels is to be constructed from the main switchgear to the final load.

It is particularly suitable, for example, where low-sensitivity residual current protection is required in both partial (current-type) and total (time-type) selective chains, and for high-sensitivity applications to protect people against indirect contact.

When the auxiliary power supply voltage drops, the opening command intervenes after a minimum time of 100ms and after the time set above 100ms.

The SACE RCQ relay is only suitable for use in the presence of alternating earth current (Type AC), for alternating and/or pulsating current with continuous components (Type A), and is suitable for achieving residual current selectivity.

The SACE RCQ relay acts indirectly, and works on the trip unit mechanism of the circuit-breaker by means of the circuit-breaker shunt opening trip unit (to be ordered by the customer) to be housed in the circuit-breaker itself.

The table below shows the main characteristics of the SACE RCQ relay.

SACE RCQ residual current switchboard relay			
Power supply voltage	AC	[V]	80 ... 500
	DC	[V]	48 ... 125
Tripping threshold setting	I _{Δn}		
- 1 st setting range		[A]	0.03 - 0.05 - 0.1 - 0.3 - 0.5
- 2 nd setting range		[A]	1 - 3 - 5 - 10 - 30
Trip time settings 1 st range		[s]	0 - 0.05 - 0.1 - 0.25
Trip time settings 2 nd range		[s]	0.5 - 1 - 2.5 - 5
Range of use of closed transformers			
- Toroidal transformer Ø 60mm		[A]	0.03 ... 30
- Toroidal transformer Ø 110mm		[A]	0.03 ... 30
Range of use of transformers that can be opened			
- Toroidal transformer Ø 110mm		[A]	0.3 ... 30
- Toroidal transformer Ø 180mm		[A]	0.1 ... 30
- Toroidal transformer Ø 230mm		[A]	0.1 ... 30
Dimensions (D x H x W)		[mm]	94 x 81 x 131.5
Drilling for assembly on door		[mm]	92 x 92

Dimensions of the external toroid for SACE RCQ						
Outer dimensions of the toroid		Closed		Openable		
	D [mm]	94	165	166	241	297
	W [mm]	118	160	200	236	292
	H [mm]	81	40	81	81	81
Internal diameter Ø [mm]		60	110	110	180	230



Switching and protection of transformers

General information

When choosing circuit-breakers to protect the LV side of MV/LV transformers, the following must basically be taken into account:

- the rated current of the protected transformer on the LV side, on which the circuit-breaker capacity and protection settings both depend;
- the maximum short-circuit current at the point of installation, which determines the minimum breaking capacity that must be offered by the protection device.

MV-LV substation with a single transformer

The rated current of the transformer, LV side, is determined by the following equation

$$I_n = \frac{S_n \times 10^3}{\sqrt{3} \times U_{20}}$$

where

S_n = rated power of the transformer, in kVA

U_{20} = rated secondary voltage (no load) of the transformer, in V

I_n = rated current of the transformer, LV side, in A (rms value)

The three-phase short-circuit current at full voltage, right at the LV terminals of the transformer, can be expressed by the following equation (assuming infinite short-circuit power at the primary):

$$I_k = \frac{I_n \times 100}{U_k\%}$$

where:

$U_k\%$ = short-circuit voltage of the transformer, in %

I_n = rated current, LV side, in A (rms value)

I_k = rated three-phase short-circuit current, LV side, in A (rms value)

If the circuit-breaker is installed some distance away from the transformer by using a cable or a bus duct connection, the short-circuit current decreases, as a function of the impedance of the connection, in comparison with the values obtained by the equation above.

In practice, the short-circuit value provided by the transformer is also affected by the short-circuit power of the S_k network to which the transformer is connected.

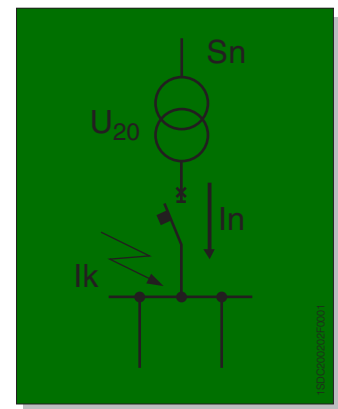

MV-LV substation with multiple transformers in parallel

The rated current of the transformer is calculated following the same procedure outlined in the previous section.

The minimum breaking capacity of each protection circuit-breaker on the LV side must be higher than the highest of the following values (the example is for machine 1 in the figure and applies to three machines in parallel):

- I_{k1} (short-circuit current of transformer 1) in the event of a fault immediately on the load side of circuit-breaker QF1;
- $I_{k2} + I_{k3}$ (I_{k2} and I_{k3} = short-circuit currents of transformers 2 and 3) in the event of a short-circuit on the supply side of circuit-breaker QF1.

Circuit-breakers QF4 and QF5 on the outgoing feeders must have a breaking capacity higher than $I_{k1} + I_{k2} + I_{k3}$; the contribution to the short-circuit current by each transformer obviously depends on the short-circuit power of the network to which it is connected, and on the line connecting the transformer and the circuit-breaker (to be determined on a case-by-case basis).

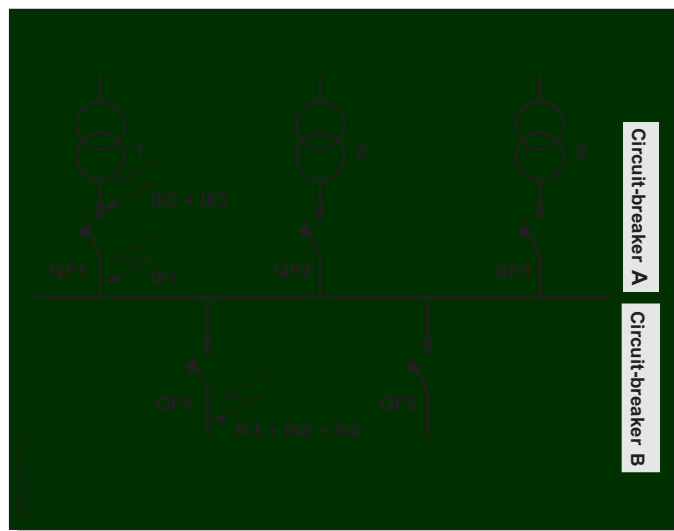



Switching and protection of transformers

Switching and protection of transformers Sk=750MVA Vn= 400V

Transformer	Circuit-breaker A (LV side)				Circuit-breaker B (Feeder circuit-breaker)											
	S (MVA)	U _n (kV)	Transf. I _n (A)	Busbar I _n (A)	Transf. Feeder I _n (kA)	Type	Tripping side	Busbar I _n (kA)	300A	1000A	1250A	1600A	2000A	2500A	3200A	4000A
1x500	4	722	722	17.7	E1B 800	In=800	17.7	E1B08*								
1x630	4	909	909	21.8	E1B 1000	In=1000	21.8	E1B08*	E1N10*	E1N12*	E1N16*					
1x800	5	1155	1155	22.6	E1B 1250	In=1250	22.6	E1B08*								
1x1000	5	1443	1443	31	E1B 1600	In=1600	31	E1B08*	E1N10*	E1N12*	E1N16*					
1x1250	5	1804	1804	34.9	E2B 2000	In=2000	34.9	E1B08*	E1B10*	E1B12*	E1B16*					
1x1600	6.25	2309	2309	47.7	E3N 2500	In=2500	47.7	E1B08*	E1B10*	E1B12*	E1B16*	E2N20*	E3N25*			
1x2000	6.25	2887	2887	44.3	E3N 3200	In=3200	44.3	E1N08*	E1N10*	E1N12*	E1N16*	E2N20*	E3N25*			
1x3125	6.25	4510	4510	67.7	E6H 5000	In=5000	67.7	E2S08*	E2S10*	E2S12*	E2S16*	E2S20*	E3S25*	E3S32*	E4S40	

Transformer	Circuit-breaker A (LV side)				Circuit-breaker B (Feeder circuit-breaker)											
	S (MVA)	U _n (kV)	Transf. I _n (A)	Busbar I _n (A)	Transf. Feeder I _n (kA)	Type	Tripping side	Busbar I _n (kA)	300A	1000A	1250A	1600A	2000A	2500A	3200A	4000A
2x500	4	722	1444	17.5	E1B 800	In=800	35.9	E1B08*								
2x630	4	909	1818	21.8	E1B 1000	In=1000	44.3	E1B08*	E1N10*	E1N12*	E1N16*					
2x800	5	1155	2310	22.1	E1B 1250	In=1250	44.3	E1N08*	E1N10*	E1N12*	E1N16*	E2N20*				
2x1000	5	1443	2886	31	E1B 1600	In=1600	53.5	E1B08*	E1N10*	E1N12*	E1N16*					
2x1250	5	1804	3608	33.8	E2B 2000	In=2000	67.7	E2S08*	E2S10*	E2S12*	E2S16*	E2S20*	E3S25*	E3S32*		
2x1600	6.25	2309	4618	47.7	E3N 2500	In=2500	67.7	E2S08*	E2S10*	E2S12*	E2S16*	E2S20*	E3S25*	E3S32*		
2x2000	6.25	2887	5774	42.6	E3N 3200	In=3200	85.1	E3H08*	E3H10*	E3H12*	E3H16*	E3H20*	E3H25*	E3H32*	E4H40	

6

Transformer	Circuit-breaker A (LV side)				Circuit-breaker B (Feeder circuit-breaker)											
	S (MVA)	U _n (kV)	Transf. I _n (A)	Busbar I _n (A)	Transf. Feeder I _n (kA)	Type	Tripping side	Busbar I _n (kA)	300A	1000A	1250A	1600A	2000A	2500A	3200A	4000A
3x630	4	909	2727	42.8	E1N 1000	In=1000	64.2	E2N10*	E2N10*	E2N12*	E2N16*	E2N20*	E3N25*			
3x800	5	1155	3465	44.3	E2N 1250	In=1250	77.7	E2S08*	E2S10*	E2S12*	E2S16*	E2S20*	E3S25*			
3x1000	5	1443	4329	53.5	E2N 1600	In=1600	80.2	E2S08*	E2S10*	E2S12*	E2S16*	E2S20*	E3H25*	E3H32*		
3x1250	5	1804	5412	53.5	E2S 2000	In=2000	80.2	E3S08*	E3S10*	E3S12*	E3S16*	E3S20*	E3S25*	E3S32*	E4S40	
3x1600	6.25	2309	6927	67	E3S 2500	In=2500	100.6	E3V08*	E3V12*	E3V12*	E3V16*	E3V20*	E3V25*	E3V32*	E4V40	

WARNING!

The table refers to the conditions specified on the previous page. The information for selecting the circuit-breakers is provided only in relation to the operating current and prospective short-circuit current. To make the correct selection, other factors such as selectivity, back-up protection, the decision to use current-limiting circuit-breakers, etc. have to be considered. It is therefore essential for designers to carry out precise verification.

The types of circuit-breakers proposed are all from the SACE Emax series. Positions marked by an asterisk (*) are suitable for other possible selections from the Tmax or Isomax series of moulded-case circuit-breakers. One also needs to bear in mind that the short-circuit currents shown in the table have been calculated on the assumption of 750MVA power on the supply side of the transformers and without taking into account the impedances of the busbars and of the connections to the circuit-breakers.

Switching and protection of transformers Sk=750MVA Vn= 690V

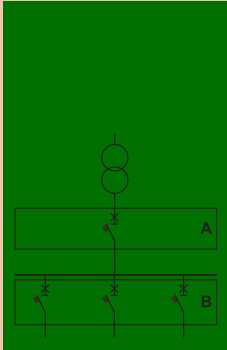
Transformer	Circuit-breaker A (LV side)				Circuit-breaker B (Feeder circuit-breaker)													
	S_t	U_n	Transf I_n	Busbar I_n	Transf Feeder I_n	Type	Trip unit size	Busbar I_n										
	(MVA)	(kV)	(A)	(A)	(kA)			(kA)	400A	630A	800A	1000A	1250A	1600A	2000A	2500A	3200A	4000A
 1x500	4	418	418	10.3	E1B 800	In=630	10.3	E1B08*										
1x630	4	527	527	12.9	E1B 800	In=630	12.9	E1B08*										
1x800	5	669	669	13.1	E1B 800	In=800	13.1	E1B08* E1B08*										
1x1000	5	837	837	16.3	E1B 1000	In=1000	16.3	E1B08* E1B08* E1B08*										
1x1250	5	1046	1046	20.2	E1B 1250	In=1250	20.2	E1B08* E1B08* E1B08*										
1x1600	6.25	1339	1339	26.7	E1B 1600	In=1600	26.7	E1B08* E1B08* E1B08* E1B10* E1B12*										
1x2000	6.25	1673	1673	25.7	E2B 2000	In=2000	25.7	E1B08* E1B08* E1B08* E1B10* E1B12* E2B16*										
1x2500	6.25	2036	2036	31.9	E3N 2500	In=2500	31.9	E1B08* E1B08* E1B08* E1B10* E1B12* E2B16*										
1x3125	6.25	2615	2615	39.2	E3N 3200	In=3200	39.2	E2B16* E2B16* E2B16* E2B16* E2B16* E2B16* E2B16* E2B20*										

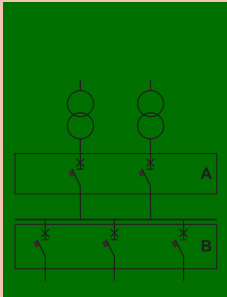
Transformer	Circuit-breaker A (LV side)				Circuit-breaker B (Feeder circuit-breaker)													
	S_t	U_n	Transf I_n	Busbar I_n	Transf Feeder I_n	Type	Trip unit size	Busbar I_n										
	(MVA)	(kV)	(A)	(A)	(kA)			(kA)	400A	630A	800A	1000A	1250A	1600A	2000A	2500A	3200A	4000A
 2x500	4	418	837	10.1	E1B800	In=630	20.2	E1B08* E1B08*										
2x630	4	527	1054	12.6	E1B800	In=630	25.3	E1B08* E1B08* E1B08*										
2x800	5	669	1339	12.8	E1B800	In=800	25.7	E1B08* E1B08* E1B08* E1B10*										
2x1000	5	837	1673	15.9	E1B1000	In=1000	31.9	E1B08* E1B08* E1B08* E1B10* E1B12*										
2x1250	5	1046	2092	19.6	E1B1250	In=1250	39.2	E2B16* E2B16* E2B16* E2B16* E2B16* E2B16*										
2x1600	6.25	1339	2678	26.1	E1B1600	In=1600	40.1	E2B16* E2B16* E2B16* E2B16* E2B16* E2B16* E2B16*										
2x2000	6.25	1673	3347	24.7	E2B2000	In=2000	49.3	E2N10* E2N10* E2N10* E2N10* E2N10* E2N12* E2N16* E2N20* E3N25*										

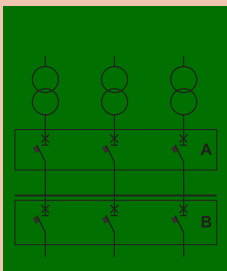
Transformer	Circuit-breaker A (LV side)				Circuit-breaker B (Feeder circuit-breaker)													
	S_t	U_n	Transf I_n	Busbar I_n	Transf Feeder I_n	Type	Trip unit size	Busbar I_n										
	(MVA)	(kV)	(A)	(A)	(kA)			(kA)	400A	630A	800A	1000A	1250A	1600A	2000A	2500A	3200A	4000A
 3x630	4	527	1581	24.8	E1B800	In=630	37.2	E2B16* E2B16* E2B16* E2B16* E2B16*										
3x800	5	669	2036	25.2	E1B800	In=800	37.7	E2B16* E2B16* E2B16* E2B16* E2B16* E2B16*										
3x1000	5	837	2510	31.0	E1B1000	In=1000	46.5	E2N10* E2N10* E2N10* E2N10* E2N10* E2N12* E2N16* E2N20*										
3x1250	5	1046	3138	39.0	E2B1600	In=1600	57.1	E2S08* E2S08* E2S08* E2S10* E2S12* E2S16* E2S20* E3N25										
3x1600	6.25	1339	4016	38.9	E2B1600	In=1600	58.3	E2S08* E2S08* E2S08* E2S10* E2S12* E2S16* E2S20* E3N25* E3N32										
3x2000	6.25	1673	5020	47.5	E2N2000	In=2000	71.2	E3S10* E3S10* E3S10* E3S10* E3S12* E3S16* E3S20* E3S25* E3S32* E4S40										

WARNING!

The table refers to the conditions specified on the previous page. The information for selecting the circuit-breakers is provided only in relation to the operating current and prospective short-circuit current. To make the correct selection, other factors such as selectivity, back-up protection, the decision to use current-limiting circuit-breakers, etc. have to be considered. It is therefore essential for designers to carry out precise verification.

The types of circuit-breakers proposed are all from the SACE Emax series. Positions marked by an asterisk (*) are suitable for other possible selections from the Tmax or Isomax series of moulded-case circuit-breakers. One also needs to bear in mind that the short-circuit currents shown in the table have been calculated on the assumption of 750MVA power on the supply side of the transformers and without taking into account the impedances of the busbars and of the connections to the circuit-breakers.



Line protection

The following main parameters must be known in order to make the correct choice of circuit-breakers for line operation and protection:

- operating current of the line I_b
- permanent current-carrying capacity of the conductor I_z
- section S and cable insulation material, with relative constant K
- short-circuit current I_k at the point of installation of the circuit-breaker.

The protection device selected must offer a breaking capacity (I_{cu} or I_{cs} at the system voltage) higher than or equal to the short-circuit value at the application point. The operating characteristics of the device selected must also meet the following conditions:

Overload protection

$$I_b \leq I_n \leq I_z$$

$$I_f \leq 1.45 I_z$$

where

I_b is the operating current of the circuit;

I_z is the permanent current-carrying capacity of the conductor;

I_n is the adjusted rated current of the protection device;

I_f is the current that ensures effective operation of the protection device.

The above inequalities are easily respected thanks to the wide setting ranges offered by the PR121-PR122-PR123 trip units.

Short-circuit protection

Assuming that a conductor overheats adiabatically during the passage of the short-circuit current, the following formula must be verified:

$$(I^2t)_{\text{circuit-breaker}} \leq (K^2S^2)_{\text{cable}}$$

therefore the specific let-through energy (I^2t) of the circuit-breaker must be lower than or equal to the specific let-through energy (K^2S^2) withstood by the cable.

Also make sure that the circuit-breaker trips within the limits prescribed by the international standards regarding the minimum value of the short-circuit current at the end of the line.

The minimum short-circuit current is the current which corresponds to a short-circuit occurring between phase and neutral (or between phase and phase if the neutral conductor is not distributed) at the farthest point of the conductor.

Protection against indirect contacts

In the event of a fault involving a phase and a part of the installation that is not normally live, it is best to make sure that the circuit-breaker trips within the times prescribed by the international standards for current values lower than or equal to the fault current.

Based on the value of this current, it is possible to intervene using function I of the trip unit, function G or, for extremely low values, the RCQ device.

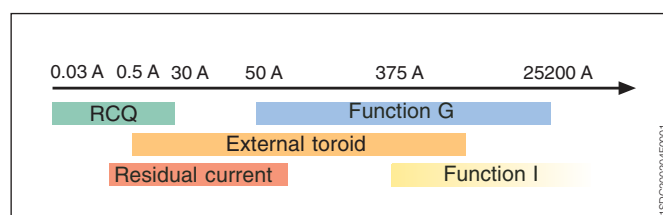

The figure shows which function of the electronic trip unit or device to use on the basis of the fault current.

Note

With regard to the verification required by the IEC 60364-4-43 Standards, which prescribe that the overload protection must have a trip current I_z ensuring effective operation of the device at a value lower than $1.45 I_z$ ($I_z < 1.45 I_b$), this is always satisfied since SACE Emax circuit-breakers comply with the CEI EN 60947-2 Standards and this value is $1.3 I_b$.

Example:

In an installation with $U_n=400V$ and $I_k=45kA$, a load with $I_b=1102A$ is supplied with 4 cables in parallel, insulated in EPR of $300mm^2$ and $I_z=1193A$

With appropriate settings, the E2N2000 $I_n=2000A$ circuit-breaker fitted with the PR122 electronic protection trip unit, protects the cable in accordance with the above conditions, as illustrated in the following graphs.

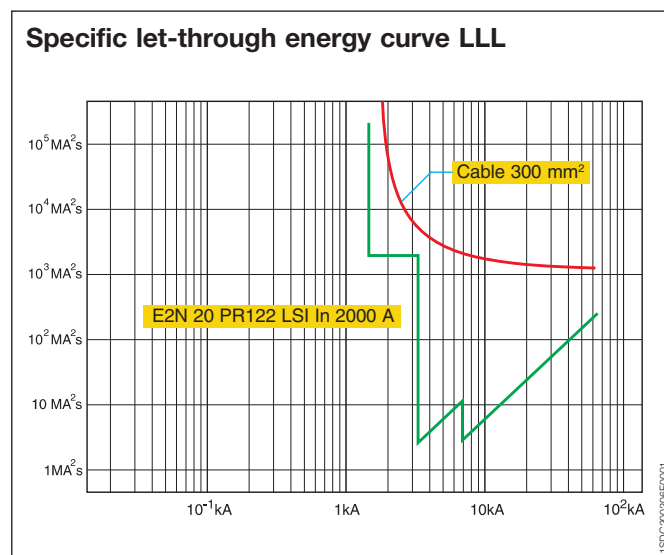
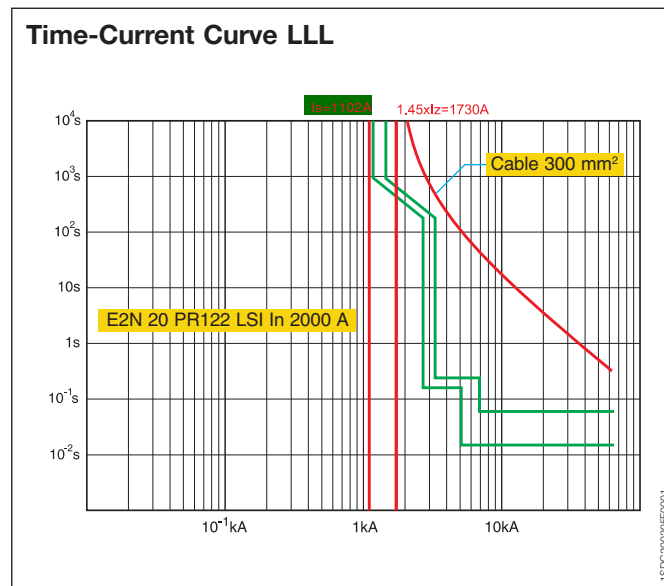

Note

For protection against indirect contacts, it may be necessary to link the setting of the short-circuit protection to the length of the line protected. See the *Slide rule kit* and DOCwin software package for the calculation procedures required. Special attention must be paid to the selective coordination of circuit-breakers in series, to limit disservice in the event of faults to a minimum.



Switching and protection of generators

Emax circuit-breakers are suitable for use with low-voltage generators employed in the following applications:

- A - back-up generators for primary loads
- B - generators disconnected from the supply network
- C - generators for small power stations connected in parallel with other generators and, possibly, with the power supply network.

In cases A and B, the generator does not operate in parallel with the power supply network: the short-circuit current therefore depends on the generator itself and, possibly, on the connected loads.

In case C, the breaking capacity must be determined by assessing the short-circuit current imposed by the network at the point of circuit-breaker installation.

The main points to check for generator protection are:

- the short-circuit current delivered by the generator; this can only be assessed if one is familiar with the machine's typical reactance and time constants. Here one can simply note that low short-circuit protection device settings are normally required (2-4 times I_n);
- the thermal overload limit of the machine. According to the IEC 60034-1 Standard, this value is set at $1.5 \times I_n$ for a period of 30 seconds.

For a detailed assessment, see the DOCWin program or specialized books on the topic.

The wide range of settings offered by electronic trip units:

PR121 Threshold I (1.5 to 15) x I_n Threshold S (1 to 10) x I_n

PR122 Threshold I (1.5 to 15) x I_n Threshold S (0.6 to 10) x I_n

PR123 Threshold I (1.5 to 15) x I_n Threshold S (0.6 to 10) x I_n

makes SACE Emax circuit-breakers perfectly suitable for protecting large generators against short-circuit currents and against thermal overloads.

Table for selecting circuit-breakers to protect generators

The table shows the rated currents of the circuit-breakers, based on the electrical specifications of the generators. The breaking capacity required by the application must be defined in order to select the appropriate circuit-breaker.

The electronic protection trip units available are suitable for all requirements.

Frequency 50 Hz - Voltage 400 V			Frequency 60 Hz - Voltage 450 V		
Rated power of the generator [kVA]	Rated current of the generator [A]	Rated current of the circuit-breaker [A]	Rated power of the generator [kVA]	Rated current of the generator [A]	Rated current of the circuit-breaker [A]
630	909	1000	760	975	1000
710	1025	1250	850	1091	1250
800	1155	1250	960	1232	1250
900	1296	1600	1080	1396	1600
1000	1443	1600	1200	1540	1600
1120	1617	2000	1344 - 1350	1724 - 1732	2000
1250	1804	2000	1500	1925	2000
1400	2021	2500	1650 - 1680 - 1700	2117 - 2155 - 2181	2500
1600	2309	2500	1920 - 1900	2463 - 2438	2500
1800	2598	3200	2160 - 2150	2771 - 2758	3200
2000	2887	3200	2400	3079	3200
2250	3246	4000	2700	3465	4000
2500	3608	4000	3000	3849	4000
3000	4341	5000	3360	4311	5000
3150	4547	5000	3780	4850	5000
3500	5252	6300	4200	5385	6300



Switching and protection of generators

Reverse power protection RP

The reverse power protection is tripped when active power is incoming to the generator rather than outgoing as it is under normal conditions. Power reversal takes place if the mechanical power supplied by the main motor driving the generator drops sharply. In this condition, the generator acts as a motor, and can cause serious damage to the prime movers, such as overheating in steam turbines, cavitation in hydraulic turbines, or explosions of uncombusted diesel fuel in diesel engines.

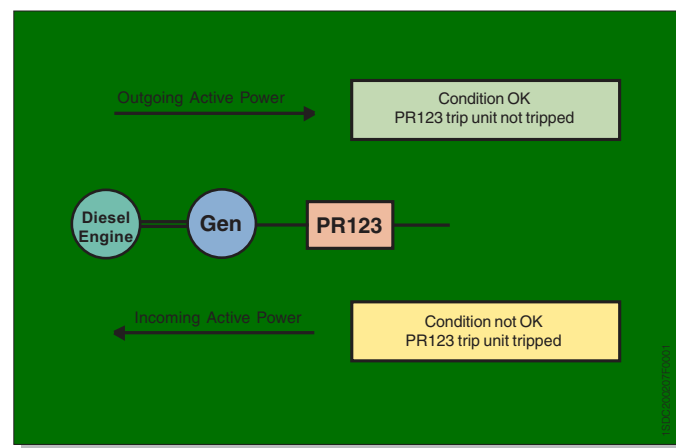

When the power measured by the trip unit falls below zero, the PR123 trip unit trips, opening the circuit-breaker and thereby preventing any damage.

Switching and protection of asynchronous motors

A low voltage automatic air circuit-breaker can, by itself, guarantee the following functions in power supply circuits of three-phase asynchronous motors:

- switching
- overload protection
- short-circuit protection.

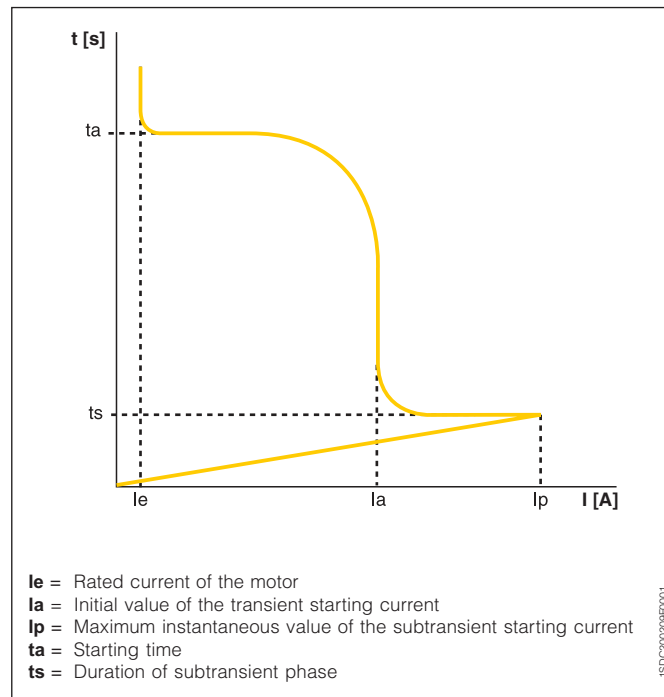

Trend of current values in the starting phase of a three-phase asynchronous motor.

This solution is particularly suitable if the switching frequency is not high, as it is normally the case for large motors. In this case, using only the circuit-breaker for motor switching and protection represents a highly advantageous solution thanks to its competitive cost-efficiency, reliability, ease of installation and maintenance, and compact overall dimensions. The circuit-breakers in the SACE Emax selective (not current-limiting) series are able to provide the motor switching and protection function by virtue of their high breaking capacities and the wide range of possible settings offered by the electronic trip units.

SACE Emax circuit-breakers are suitable for use with motors with rated powers within the range between 355 kW and 630 kW. For power ratings up to 355 kW, the moulded-case circuit-breakers in the SACE Isomax and Tmax range are also available. Medium voltage power supplies are normally used for powers above 630 kW.

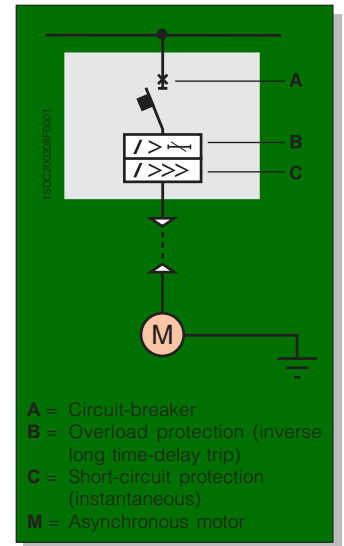

Diagram showing direct starting of an asynchronous motor using just the circuit-breaker fitted with an electronic overcurrent trip unit.



Switching and protection of asynchronous motors

The switching of three-phase asynchronous motors demands considerable attention to the starting operation, since the current during this phase follows the typical behaviour shown in the figure, which must be taken into account when selecting the protection devices.

It is essential to calculate the typical values of the times and currents indicated in the figure in order to select the correct switching and protection devices for the motor. These data are normally provided by the motor manufacturer.

The following ratios generally apply:

- $I_a = 6-10 I_e$ (I_a and I_e : rms values)
- $I_p = 8-15 I_e$ (I_p and I_e : rms values).

The protection trip units must be adjusted so as to:

- prevent unwanted tripping
- ensure that the installation is protected against the overcurrents which might occur at any point on the load side of the circuit-breaker (including internal motor faults).

The inverse long time-delay trip protection and instantaneous short-circuit protection must be set as close as possible to the motor starting curve without, however, interfering with it.

Note

The IEC 60947-4-1 Standard covers motor starters. The following classes are considered for overload protection:

Operating class	Trip time t (s) for $I = 7.2 \times I_1$ ($I_1 =$ release setting current)
10	$4 < t \leq 10$
20	$6 < t \leq 20$
30	$9 < t \leq 30$

The table specifies that the protection device must trip in a time t within the limits for its class when the current flowing through the device to be protected is 7.2 times the trip unit setting current (assumed to be equal to the rated current of the motor).

The overload devices are divided into classes in a manner closely linked to the motor starting time: for example, a motor with a starting time of 5 seconds requires a protection device in class 20.

The same standards provide specific prescriptions for the protection device in cases of three-phase operation or with the loss of a phase.

Warning

The curves of the motor and trip units are not directly comparable, since they both express time-current links, but have conceptually different meanings:

- the motor starting curve represents the values taken by the starting current instant by instant;
- the trip unit curve represents the currents and corresponding trip times for the protection device.

The overload trip curve is set correctly when it is immediately above point A (figure below), which identifies the top of the rectangle with sides formed by the starting time “ t_a ” and the current “ I_a ” thermally equivalent to the variable starting current respectively.

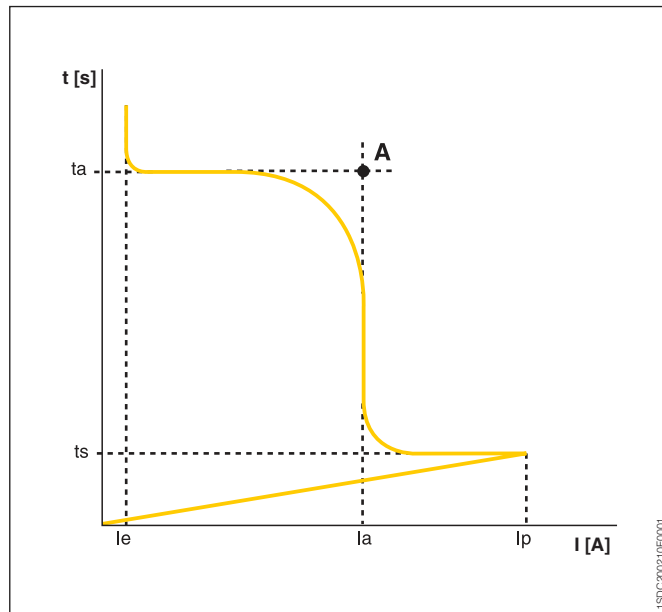

Three-phase operation

The overload protection device at 1.05 times the setting current shall not trip in less than 2 hours starting from the cold state.

When the current is 1.2 times the setting current, the tripping shall occur in less than 2 hours, as indicated in the table which follows (page 6/39)



Switching and protection of asynchronous motors

Operation with the loss of a phase

The IEC 60947-4-1 Standard prescribes that a trip unit, with compensated temperature and sensitive to phase losses, must:

- not trip in less than two hours at 20°C, when one phase carries 90% of I_n and the other two carry 100% of I_n
- trip in less than two hours at 20°C, in the event of the loss of a phase when the current in the energized poles reaches 1.15 times the rated current I_n .

With the PR122 and PR123 trip units by activating the Unbalance function it is possible to check the losses of phase.

Selecting the circuit-breakers to be used for motor protection

The tables in the next pages show the rated characteristics for large motors, from 355 to 630 kW, with circuit-breakers in the SACE Emax series for switching and protecting motors in category AC-3 at 415/690 V - 50 Hz.

The tables show the choice of current transformers able to ensure a sufficiently high value for the instantaneous trip threshold setting (I): in the absence of experimental data, it is advisable to verify that the ratio between the threshold of protection device I (I3) and the threshold of protection device L (I1) is:

$$I3/I1 = 12 \dots 15.$$

The PR122 and PR123 electronic trip units conform to the international IEC 60947-4-1 Standard. In particular, the devices ensure protection of class 10A, 10, 20 and 30 of motors. PR122 and PR123 protection trip units are compensated in temperature, and their operation is not negatively affected by the loss of a phase.

Advantages of earth fault protection G

The earth fault protection (G) is recommended in order to:

- improve safety against fire hazards
- improve protection of motors and personnel in the event of machine faults.

Advantages of thermal memory

The advisability of enabling the thermal memory (option offered by PR122 and PR123 trip units) must be evaluated in relation to the type of load. Enabling the thermal memory (which makes the electronic protection similar to the one provided by a thermomagnetic device) increases the protection level of the motor when restarting after tripping due to an overload.

Undervoltage protection

The undervoltage protection device in control systems for asynchronous motors demands special attention, performing, amongst other things, two important functions:

- it prevents simultaneous restarting of all the motors on return of the power supply, with the risk of making the entire installation go out of service by tripping the main circuit-breaker overcurrent protection devices
- it prevents the motor from restarting without a control signal, which could be a hazard for maintenance personnel or could damage the processing cycle.

This protection can be carried out by:

- undervoltage trip unit,
- protection function UV (undervoltage) on the PR123 trip unit.

I/In	1.05	1.2	1.5	7.2	Operating class
Tp	> 2h	< 2h	< 120 s	2 < t ≤ 10s	10A
			< 240 s	4 < t ≤ 10s	10
			< 480 s	6 < t ≤ 20s	20
			< 720 s	9 < t ≤ 30s	30

Direct On Line – Normal Start-Up – 415V – 50Hz

Motor		SACE Emax circuit-breaker			Electronic trip unit	
Pe [kW]	Ie [A]	Operations (AC-3) [No.]	Type	Icu [kA]	Type	In [A]
220	368	10000	E1B08	42	PR122/PR123	630
250	415	10000	E1B08	42	PR122/PR123	630
315	521	10000	E1B10	42	PR122/PR123	800
355	588	10000	E1B10	42	PR122/PR123	800
400	665	10000	E1B12	42	PR122/PR123	800
450	743	10000	E1B12	42	PR122/PR123	1000
500	819	10000	E1B16	42	PR122/PR123	1000
560	916	10000	E1B16	42	PR122/PR123	1250
630	1022	10000	E1B16	42	PR122/PR123	1250
220	368	10000	E1N08	50	PR122/PR123	630
250	415	10000	E1N08	50	PR122/PR123	630
315	521	10000	E1N10	50	PR122/PR123	800
355	588	10000	E1N10	50	PR122/PR123	800
400	665	10000	E1N12	50	PR122/PR123	800
450	743	10000	E1N12	50	PR122/PR123	1000
500	819	10000	E1N16	50	PR122/PR123	1000
560	916	10000	E1N16	50	PR122/PR123	1250
630	1022	10000	E1N16	50	PR122/PR123	1250
220	368	15000	E2N10	65	PR122/PR123	630
250	415	15000	E2N10	65	PR122/PR123	630
315	521	15000	E2N10	65	PR122/PR123	800
355	588	15000	E2N12	65	PR122/PR123	800
400	665	15000	E2N12	65	PR122/PR123	800
450	743	15000	E2N12	65	PR122/PR123	1000
500	819	12000	E2N16	65	PR122/PR123	1000
560	916	12000	E2N16	65	PR122/PR123	1250
630	1022	12000	E2N16	65	PR122/PR123	1250
220	368	12000	E3H08	100	PR122/PR123	630
250	415	12000	E3H08	100	PR122/PR123	630
315	521	12000	E3H10	100	PR122/PR123	800
355	588	12000	E3H10	100	PR122/PR123	800
400	665	12000	E3H12	100	PR122/PR123	800
450	743	12000	E3H12	100	PR122/PR123	1000
500	819	10000	E3H16	100	PR122/PR123	1000
560	916	10000	E3H16	100	PR122/PR123	1250
630	1022	10000	E3H16	100	PR122/PR123	1250



Switching and protection of asynchronous motors

Direct On Line – Normal Start-Up – 690V – 50Hz

Motor		SACE Emax circuit-breaker			Electronic trip unit	
P _n (kW)	I _n (A)	Operations (AC-3) (No.)	Type	I _{cu} (kA)	Type	I _n (A)
220	221	10000	E1B08	36	PR122/PR123	630
250	249	10000	E1B08	36	PR122/PR123	630
315	313	10000	E1B08	36	PR122/PR123	630
350	350	10000	E1B08	36	PR122/PR123	630
400	400	10000	E1B08	36	PR122/PR123	630
450	447	8000	E1B10	36	PR122/PR123	630
500	493	8000	E1B10	36	PR122/PR123	800
550	551	8000	E1B12	36	PR122/PR123	800
630	615	8000	E1B12	36	PR122/PR123	800
220	221	15000	E2N10	55	PR122/PR123	630
250	249	15000	E2N10	55	PR122/PR123	630
315	313	15000	E2N10	55	PR122/PR123	630
350	350	15000	E2N10	55	PR122/PR123	630
400	400	15000	E2N10	55	PR122/PR123	630
450	447	15000	E2N10	55	PR122/PR123	800
500	493	15000	E2N10	55	PR122/PR123	800
550	551	15000	E2N12	55	PR122/PR123	800
630	615	15000	E2N12	55	PR122/PR123	800
220	221	12000	E3S10	75	PR122/PR123	630
250	249	12000	E3S10	75	PR122/PR123	630
315	313	12000	E3S10	75	PR122/PR123	630
350	350	12000	E3S10	75	PR122/PR123	630
400	400	12000	E3S10	75	PR122/PR123	630
450	447	12000	E3S10	75	PR122/PR123	800
500	493	12000	E3S10	75	PR122/PR123	800
550	551	12000	E3S12	75	PR122/PR123	800
630	615	12000	E3S12	75	PR122/PR123	800
220	221	12000	E3V08	100	PR122/PR123	630
250	249	12000	E3V08	100	PR122/PR123	630
315	313	12000	E3V08	100	PR122/PR123	630
350	350	12000	E3V08	100	PR122/PR123	630
400	400	12000	E3V08	100	PR122/PR123	630
450	447	12000	E3V10	100	PR122/PR123	800
500	493	12000	E3V10	100	PR122/PR123	800
550	551	12000	E3V12	100	PR122/PR123	800
630	615	12000	E3V12	100	PR122/PR123	800

Operating conditions of circuit-breakers during continuous service for capacitor banks

According to the IEC 60831-1 and 60931-1 Standards, capacitors must be able to operate in service conditions with a rated rms current of up to 1.3 times the rated current I_{cn} of the capacitor. This prescription is due to the possible presence of harmonics in the mains voltage.

It should also be kept in mind that a tolerance of +15% is admissible for the capacitance value corresponding to its rated power, so that the circuit-breakers for switching capacitor banks must be selected to permanently carry a maximum current equal to:

$$I_n = 1.3 \times 1.15 \times I_{cn} = 1.5 \times I_{cn}$$

Current for connecting capacitor banks

Connection of a capacitor bank can be compared to a closing operation under short-circuit conditions, where the transient making capacity I_p takes on high peak values, above all when capacitor banks are connected in parallel with others that are already powered. The value of I_p needs to be calculated for each individual situation because it depends on the individual circuit conditions and can in certain cases even have a peak value equal to 100-200 x I_{cn} for a duration of 1-2 ms.

This fact must be taken into account when selecting the circuit-breaker, which must have a suitable making capacity, and when setting the overcurrent release, which must not cause unwanted trips when the bank is connected.

Selecting the circuit-breaker

Using the information on the rating plate of the three-phase capacitor bank

Q_n = rated power in kvar

U_n = rated voltage in V

the rated current of the capacitor bank is determined as follows:

$$I_{cn} = \frac{Q_n \times 10^3}{\sqrt{3} \times U_n} \quad , \text{ in A.}$$

The following conditions must be verified for the circuit-breaker:

Rated current $I_n > 1.5 I_{cn}$

Overload protection setting $I_1 = 1.5 \times I_{cn}$

Short-circuit protection setting $I_3 = \text{OFF}$

Breaking capacity $I_{cu} \geq I_k$, at the point of installation.



Switching and protection of capacitors

Table for selecting the protection and switching circuit-breakers for capacitors

The breaking capacity of the circuit-breaker must take into account the prospective short-circuit current at the point of installation. The available sizes are shown in the table.

Maximum power of the capacitor bank at 50Hz [kvar]				Circuit-breaker Type	Rated current of the current transformer In [A]	Rated current of the capacitor bank Inc [A]	Overload protection setting I1 [A]	Short-circuit protection setting I3 [A]
400V	440V	500V	690V					
576	636	720	907	E1 - E2 - E3	1200	800	1 x In	OFF
739	813	924	1275	E1 - E2 - E3	1600	1067	1 x In	OFF
1155	1270	1444	1992	E3	2500	1667	1 x In	OFF

Note

The E2L and E2L circuit-breakers are not suitable for switching capacitor banks.

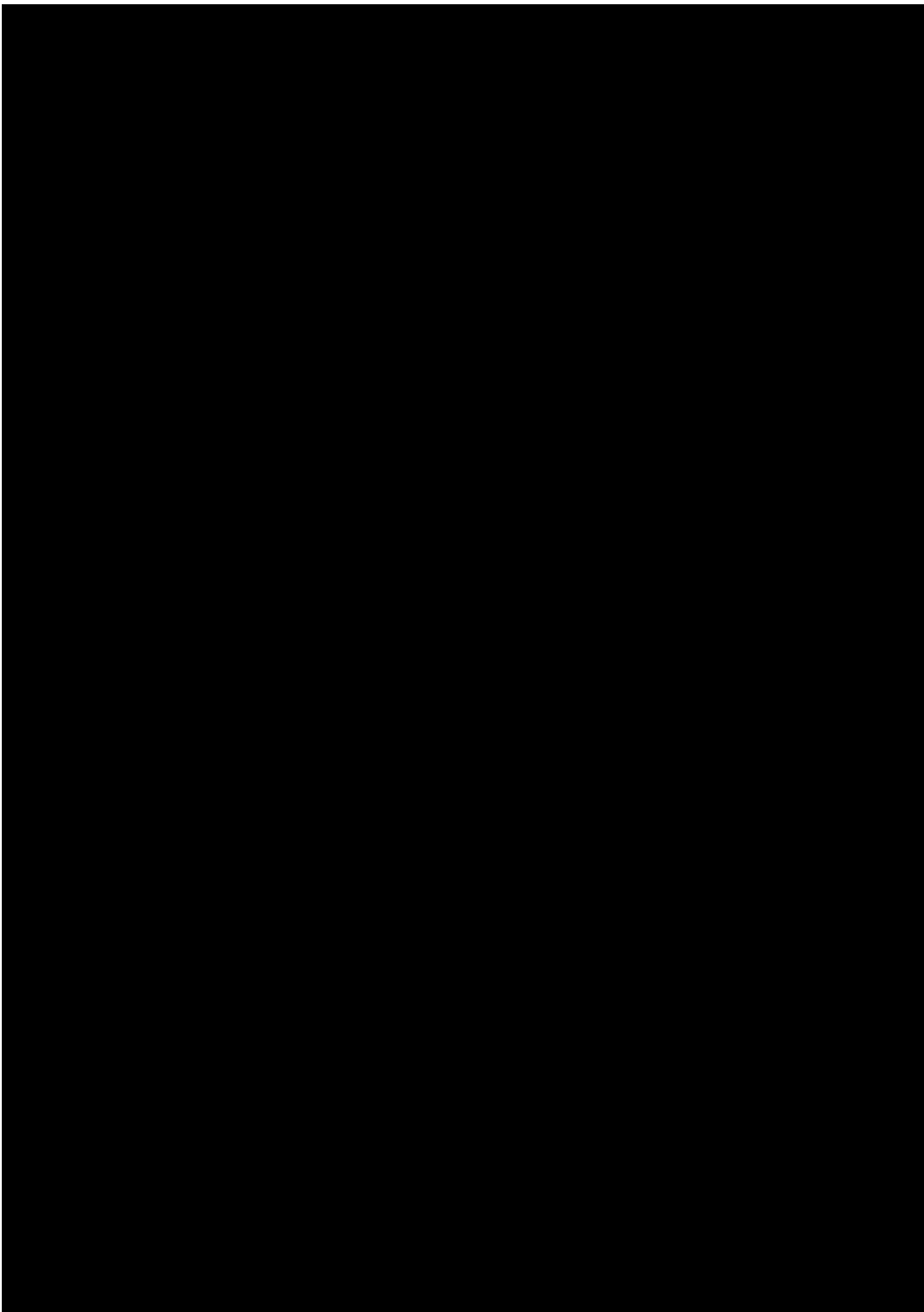

Emmax

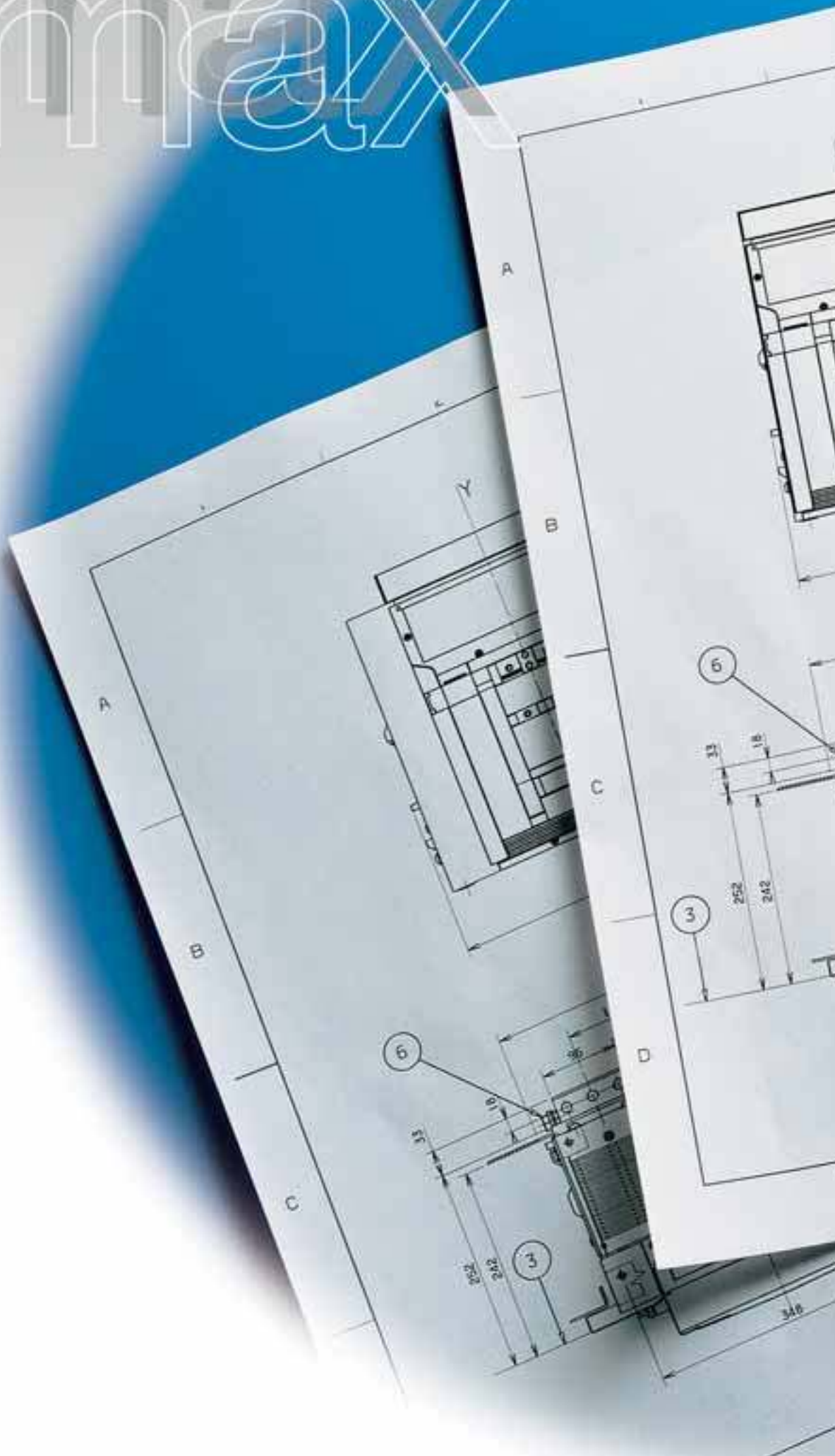



Overall dimensions

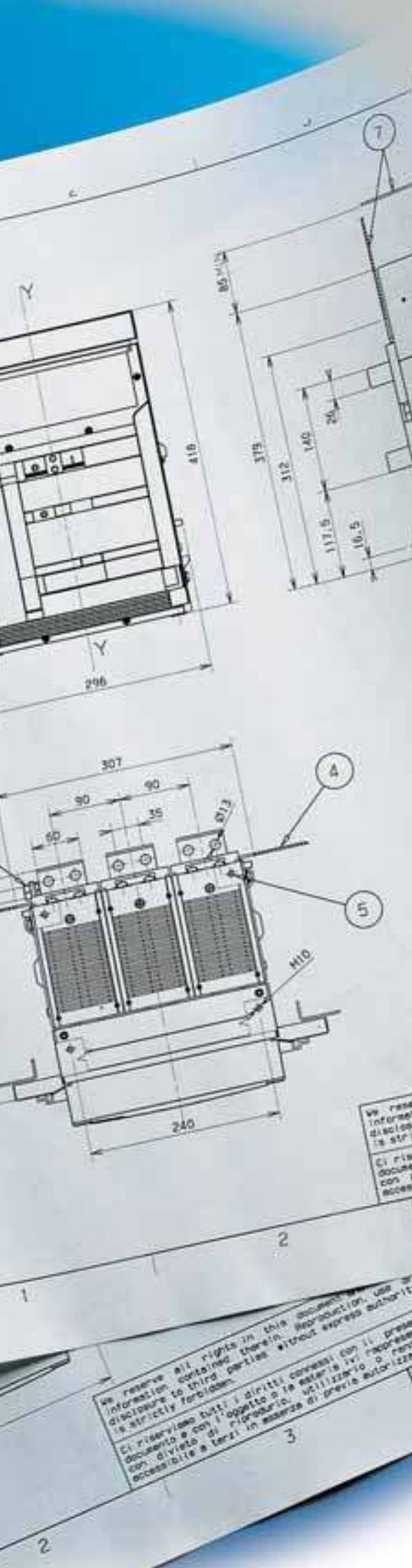

Contents

Fixed circuit-breaker	7/2
Withdrawable circuit-breaker	7/8
Mechanical interlock	7/15
Circuit-breaker accessories	7/17



Overall dimensions

Fixed circuit-breaker

Basic version with horizontal rear terminals

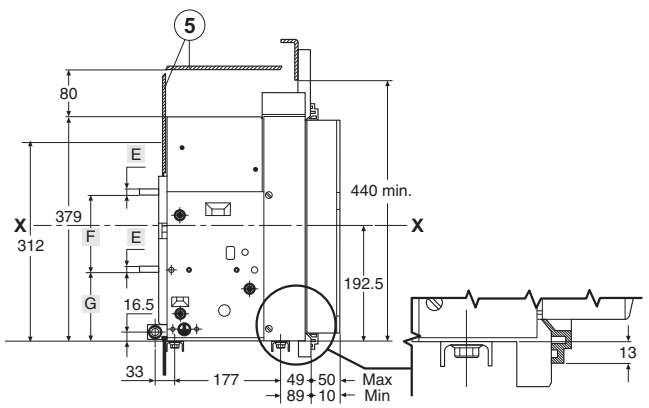
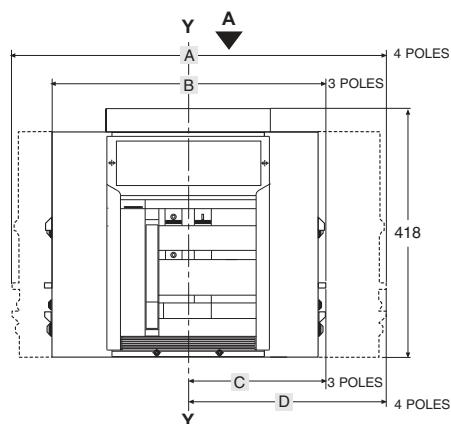

Caption

- ① Inside edge of compartment door
- ② Segregation (when provided)
- ③ M10 mounting holes for circuit-breaker (use M10 screws)
- ④ 1xM12 screw (E1, E2, E3) or 2 x M12 screws (E4, E6) for earthing (included in the supply)
- ⑤ Insulating wall or insulated metal wall

E1/E2
View A

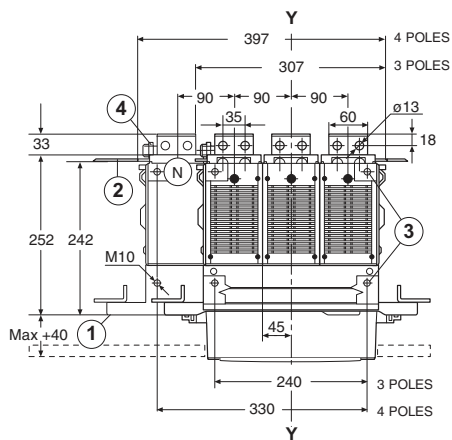

E3

View A

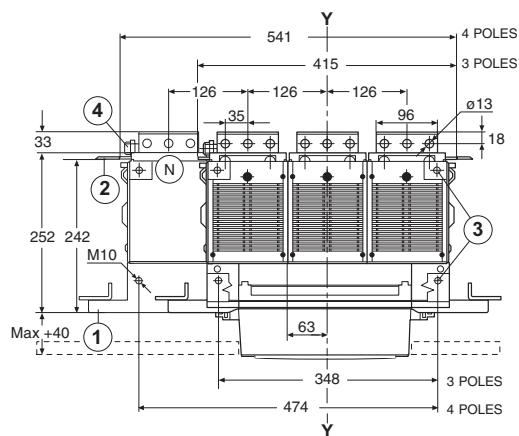

7

	A	B	C	D	E	F	G
E1	386	296	148	148	10	130	117.5
E2	386	296	148	148	26	114	117.5
E3	530	404	202	202	26	114	117.5
E4	656	566	238	328	26	166	91.5
E4/f	746	-	-	328	26	166	91.5
E6	908	782	328	454	26	166	91.5
E6/f	1034	-	-	454	26	166	91.5



Overall dimensions

Fixed circuit-breaker

Basic version with vertical rear terminals

E1

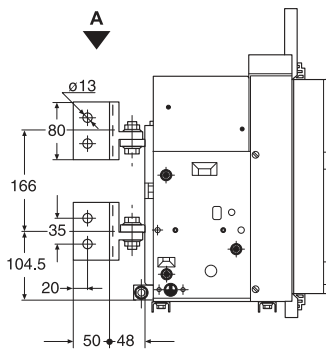

E2/E4

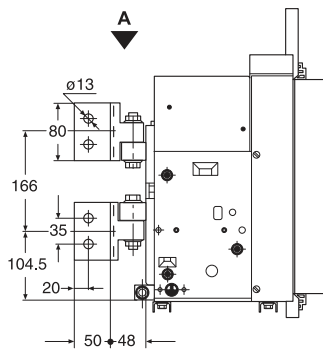

E3/E6

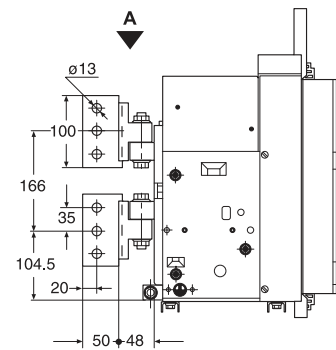

E1

View A

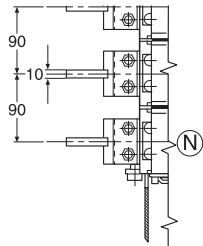

E2

View A

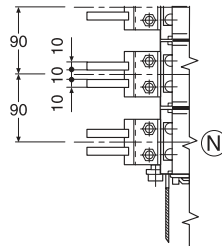

E3

View A

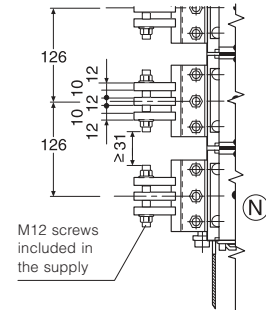

E4

View A

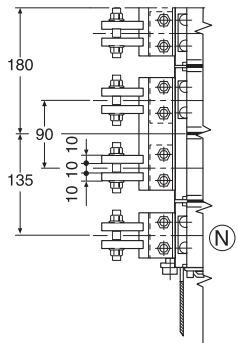

E4/f

View A

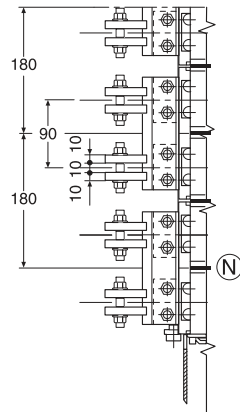

E6

View A

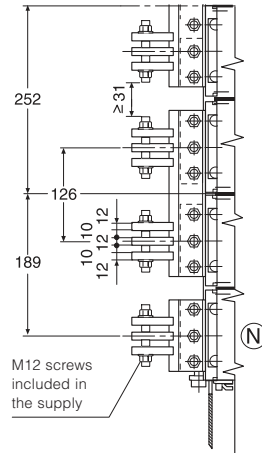

E6/f

View A

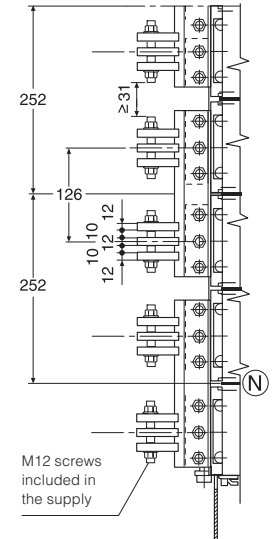

1SDC2021EF0001

**Version with
front terminals**

E1

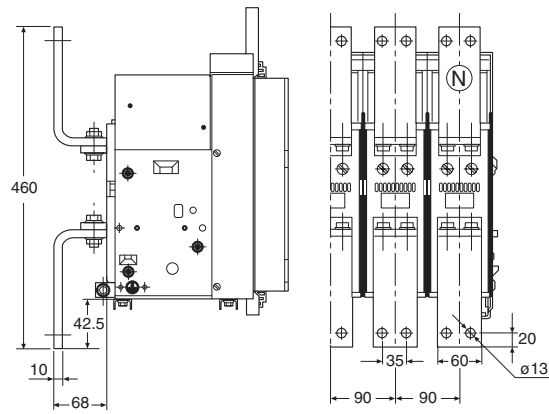

E2

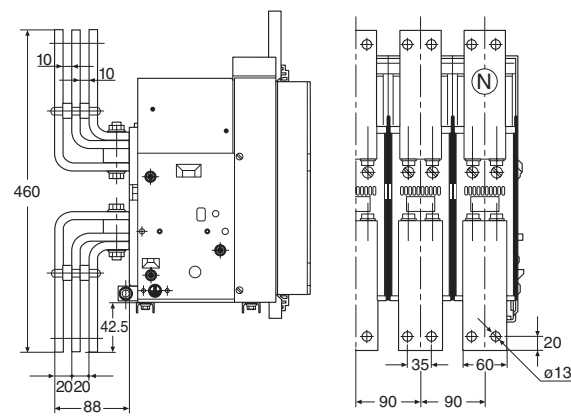

E3

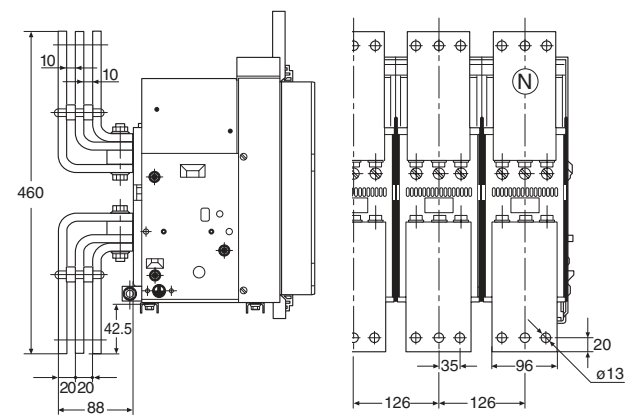

1SDC200217T0001

Overall dimensions

Fixed circuit-breaker

Version with front terminals

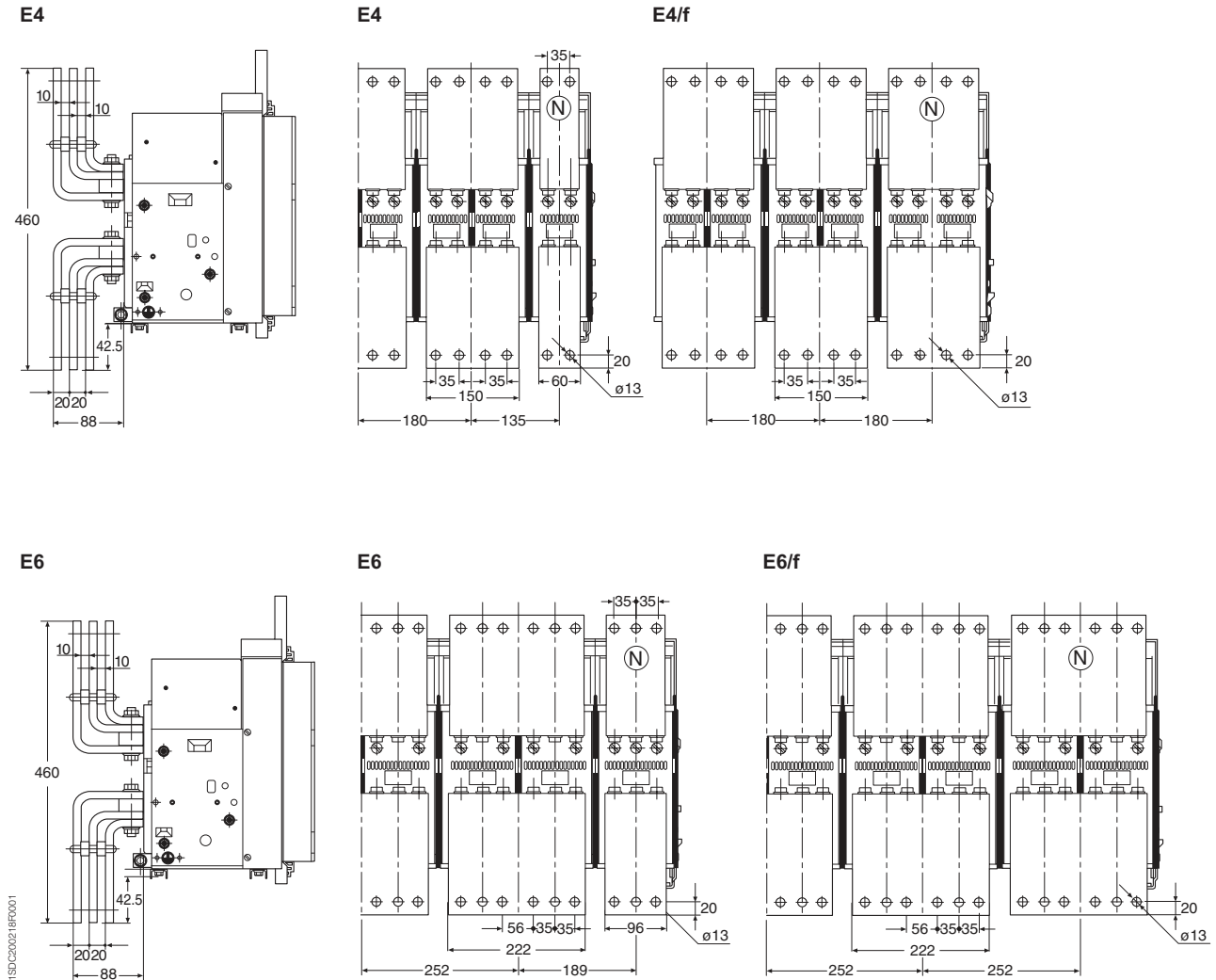

Compartment dimensions

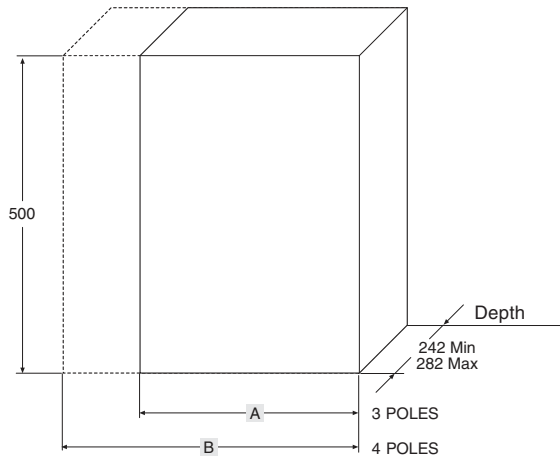

Drilling of compartment door

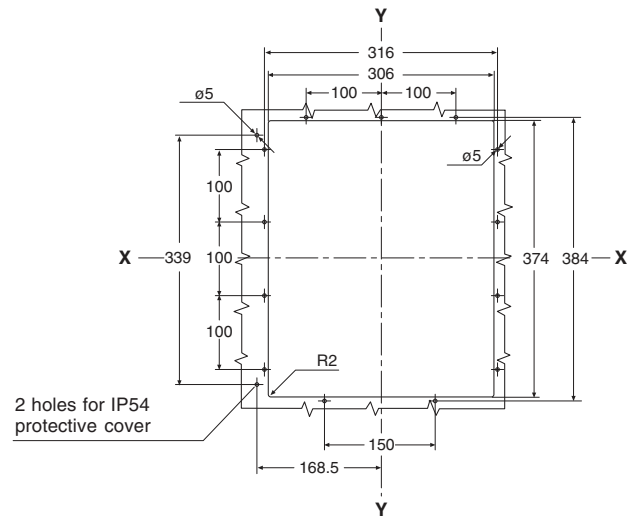

Through-holes for flexible cables for mechanical interlocks

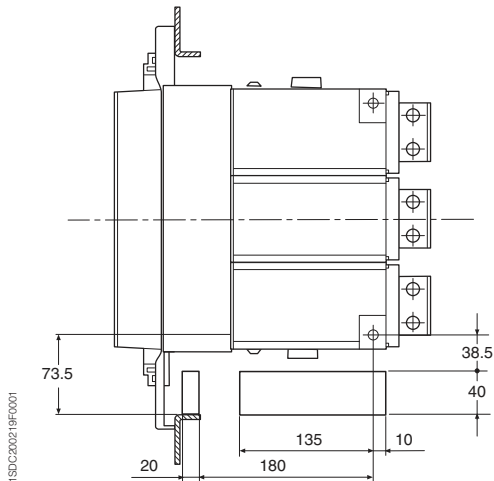

Tightening torque for main terminals Nm 70 Tightening torque for earthing screw Nm 70

	High strength M12 screw Number per terminal	
	PHASE	NEUTRAL
E1-E2	2	2
E3	3	3
E4-E4/f	4	2-4
E6-E6/f	6	3-6

	A	B
E1	400	490
E2	400	490
E3	500	630
E4	700	790
E4/f	-	880
E6	1000	1130
E6/f	-	1260

Overall dimensions

Withdrawable circuit-breaker

Basic version with horizontal rear terminals

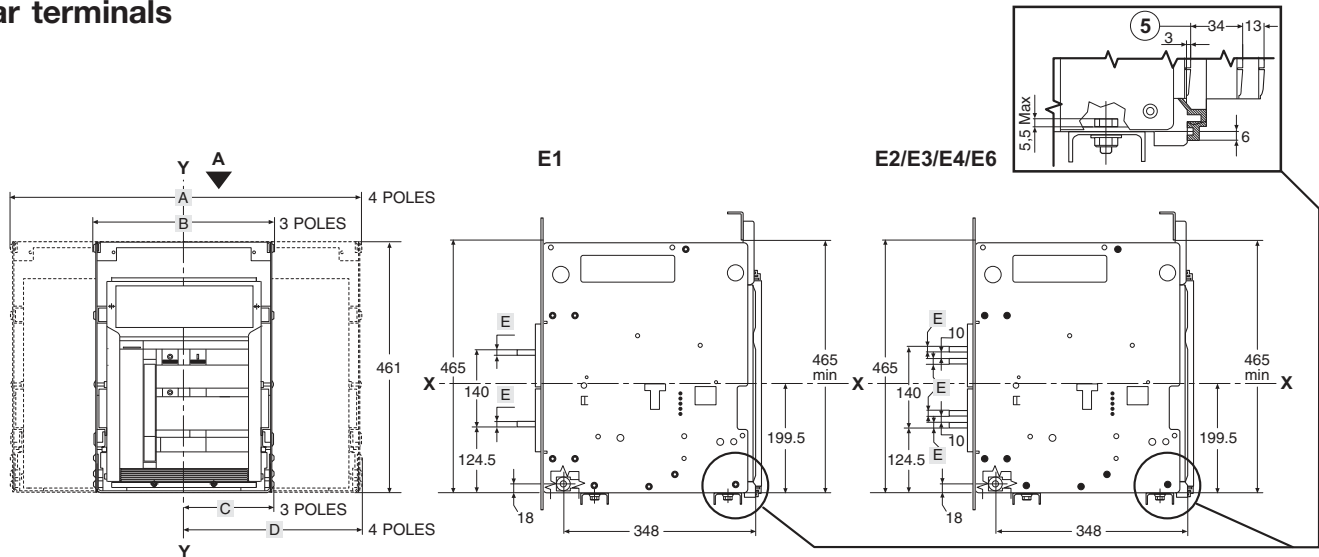

Caption

- ① Inside edge of compartment door
- ② Segregation (when provided)
- ③ $\varnothing 10$ mounting holes for fixed part (use M8 screws)
- ④ 1x M12 screw (E1, E2, E3) or 2xM12 screws (E4, E6) for earthing (included in the supply)
- ⑤ Distance from connected for testing to isolated
- ⑥ Alternative drilling with 25 mm pitch for fixing fixed part
- ⑦ Ventilation drilling on the switchgear

E1/E2

View A

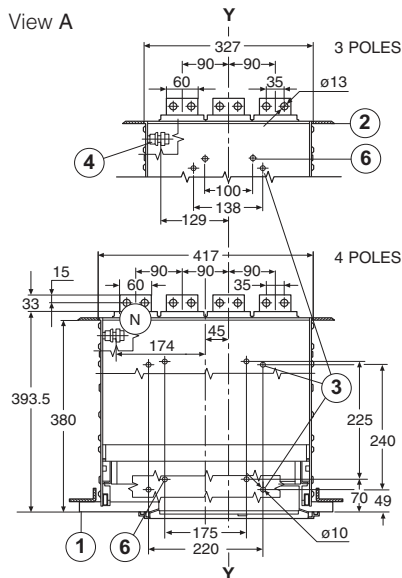

E3

View A

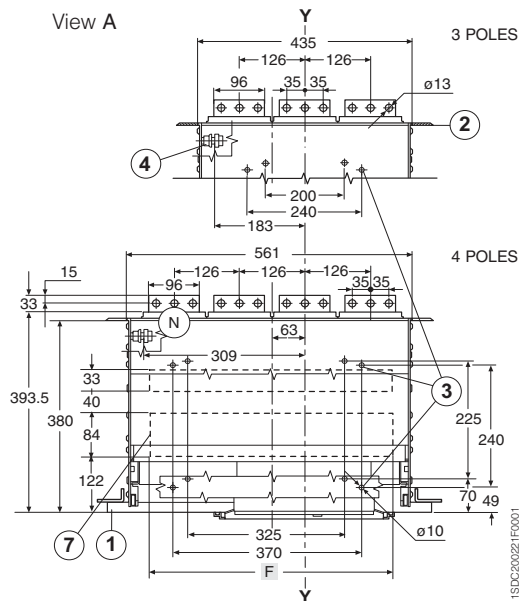

	A	B	C	D	E	F	
					3 poles 4 poles		
E1	414	324	162	162	10	-	-
E2	414	324	162	162	8	-	-
E3	558	432	216	216	8	370	490
E4	684	594	252	342	8	530	610
E4/f	774	-	-	342	8	-	700
E6	936	810	342	468	8	750	870
E6/f	1062	-	-	468	8	-	1000

E4

View A

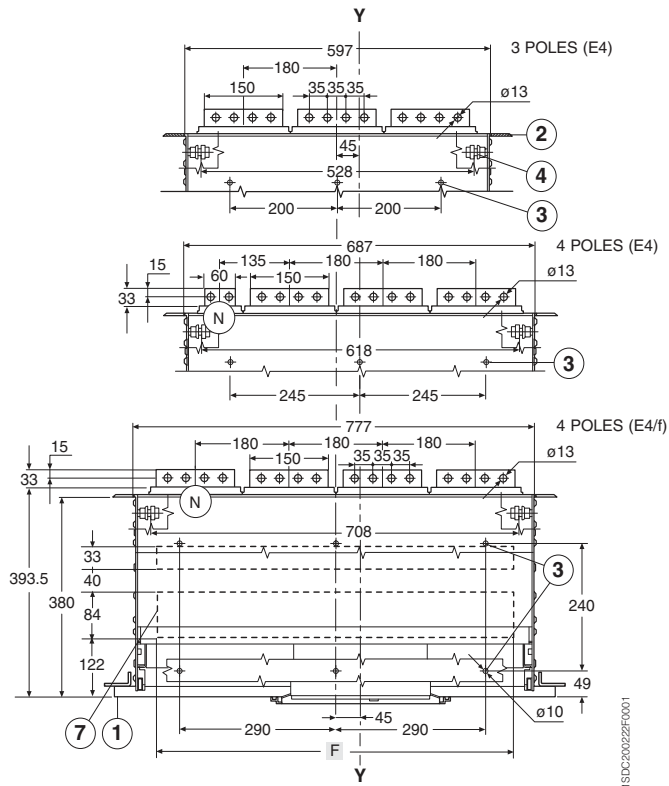

E6

View A

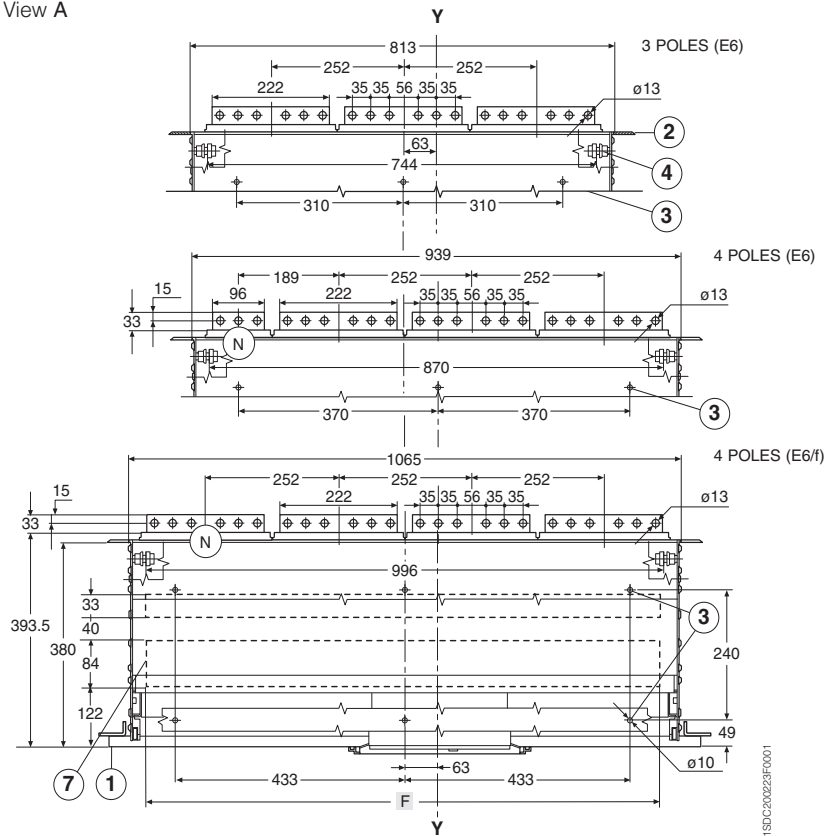



Overall dimensions

Withdrawable circuit-breaker

Basic version with vertical rear terminals

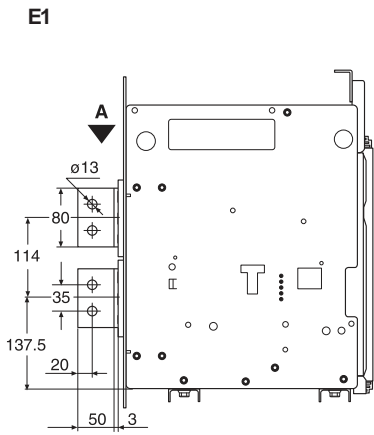

E1
View A

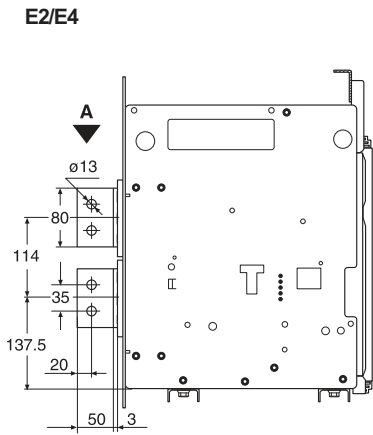
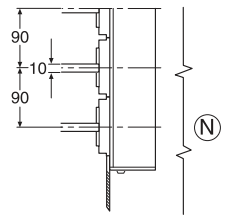

E2
View A

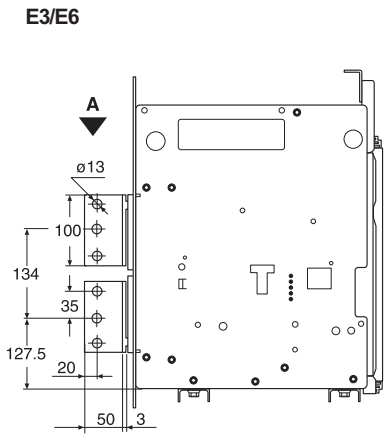
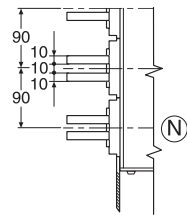

E3
View A

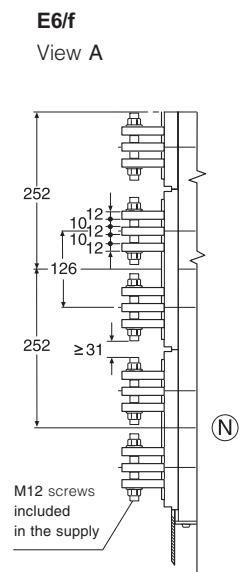
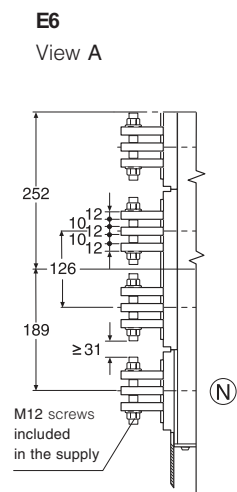
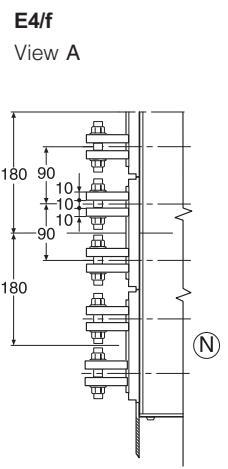
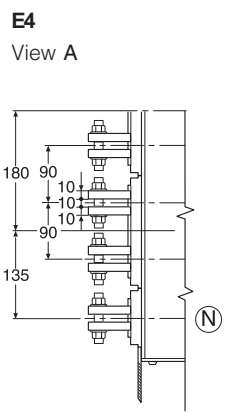
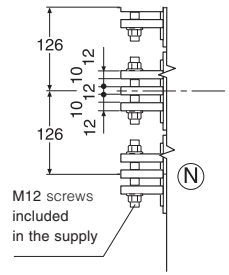

1SDJ200224E0001

**Version with
front terminals**

E1

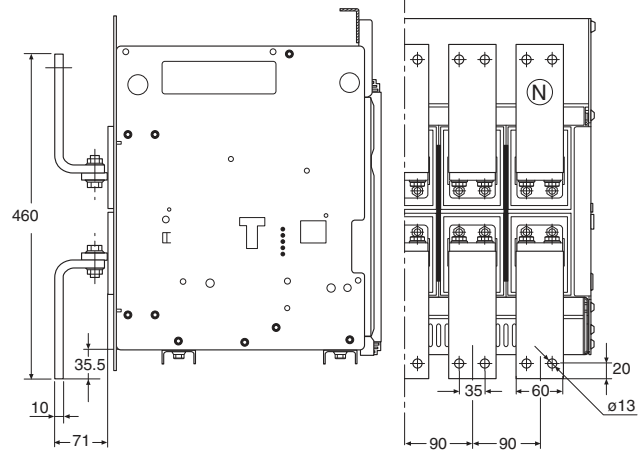

E2

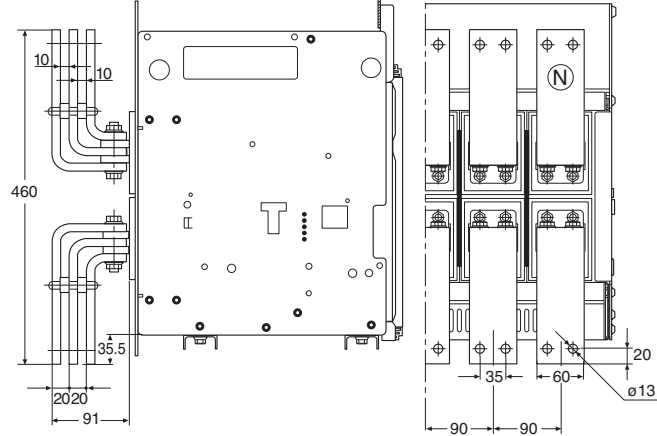

E3

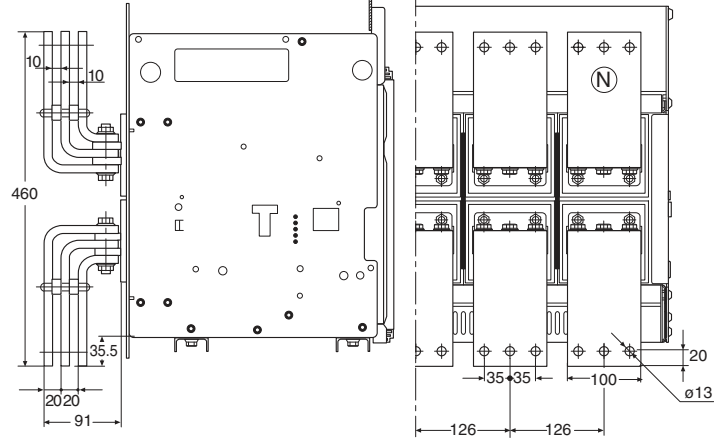

1SDJ200225F0001

Overall dimensions

Withdrawable circuit-breaker

Version with front terminals

E4

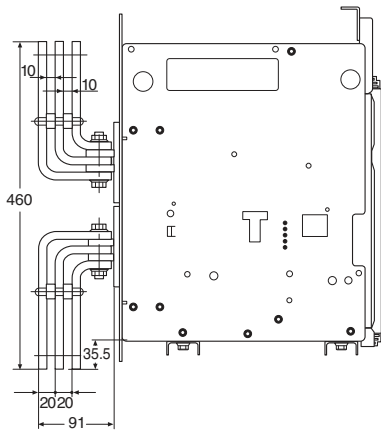

E4

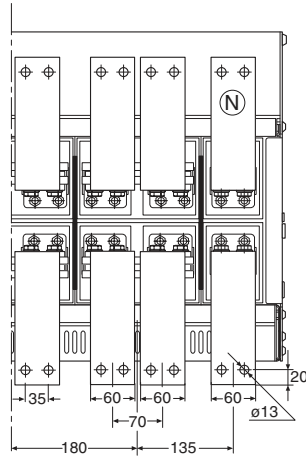

E4/f

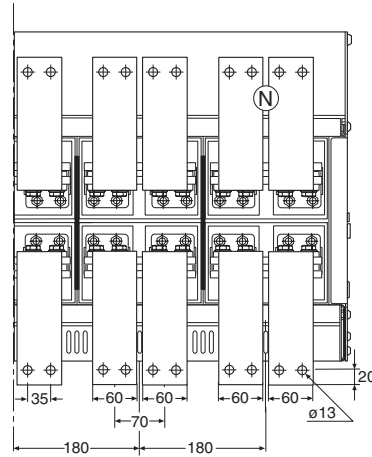

E6

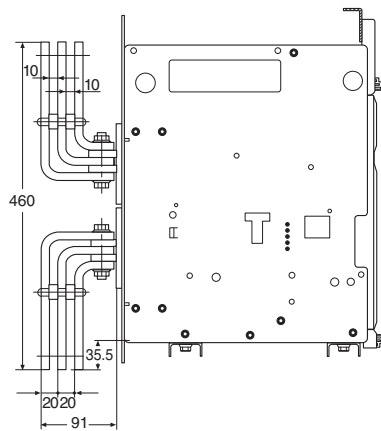

E6

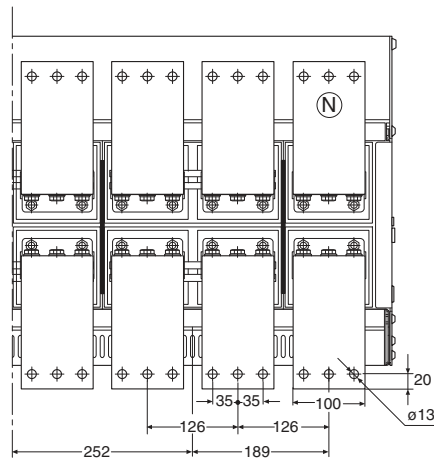

E6/f

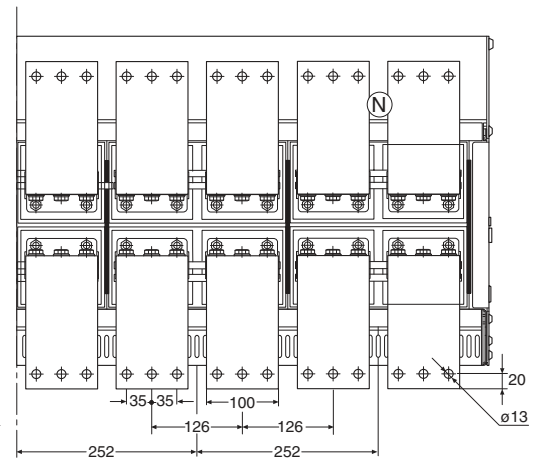

1SDC20028F0001

**Version with
flat terminals**

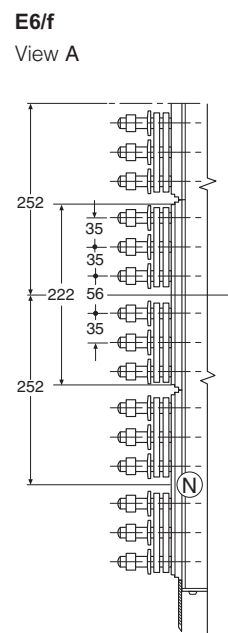
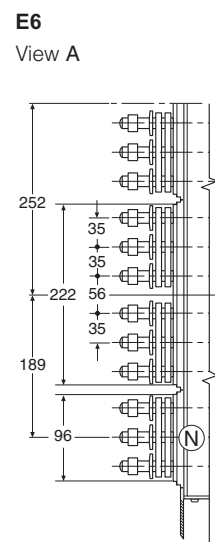
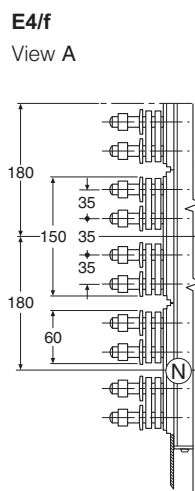
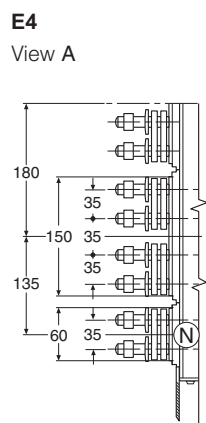
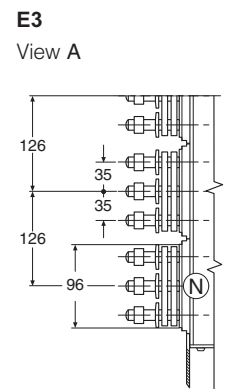
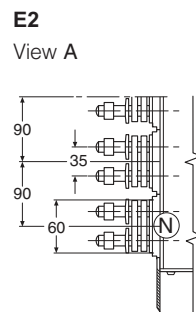
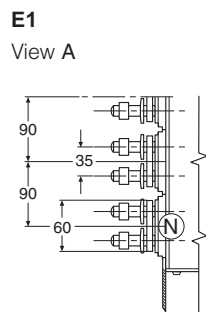
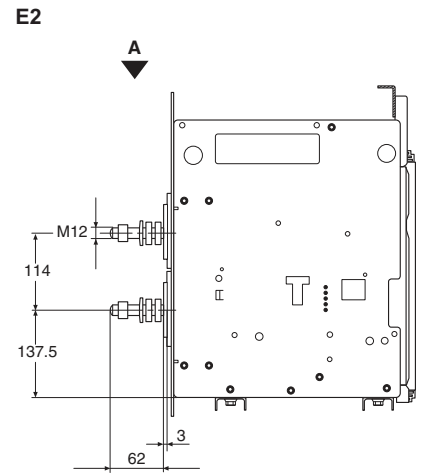
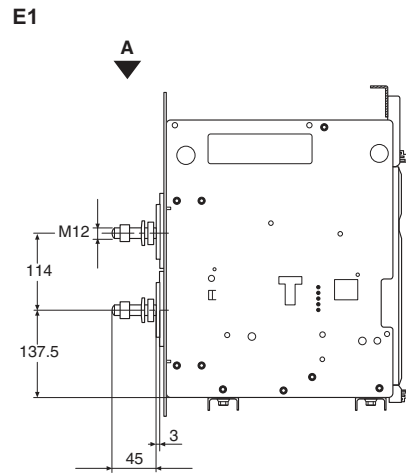

ISDC200227F001



Overall dimensions

Withdrawable circuit-breaker

Compartment dimensions

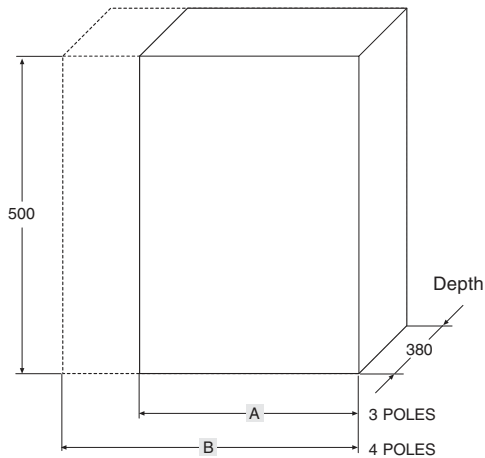

Drilling of compartment door

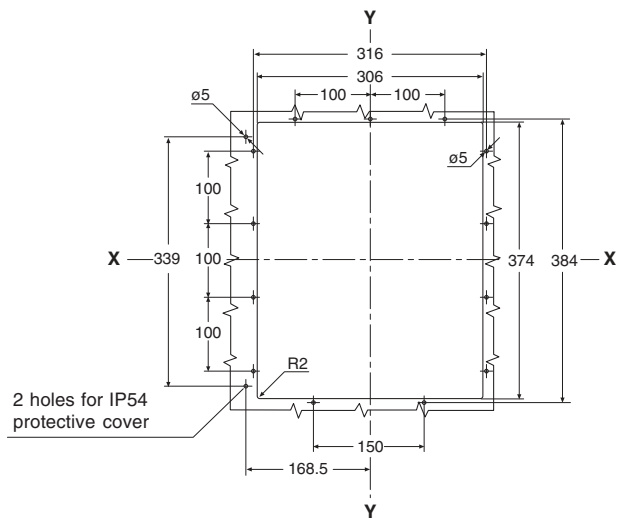

Through-holes for flexible cables for mechanical interlocks

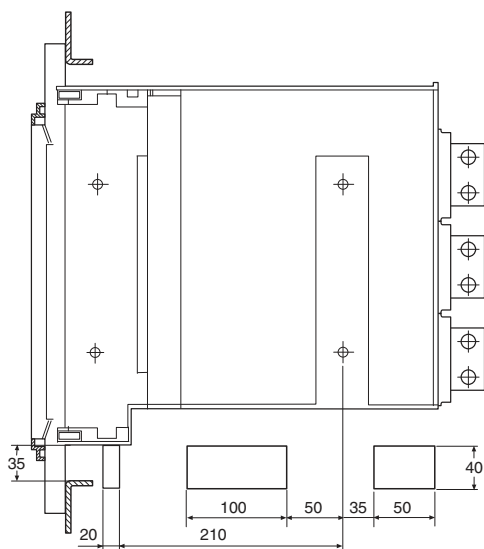

Tightening torque for fastening screws Nm 20 Tightening torque for main terminals Nm 70 Tightening torque for earthing screw Nm 70

	High strength M12 screw Number per terminal	
	PHASE	NEUTRAL
E1-E2	2	2
E3	3	3
E4-E4/f	4	2-4
E6-E6/f	6	3-6

	A	B
E1	400	490
E2	400	490
E3	500	630
E4	700	790
E4/f	-	880
E6	1000	1130
E6/f	-	1260

7

Overall dimensions

Mechanical interlock

Interlock assembly

Type A

Horizontal
Vertical

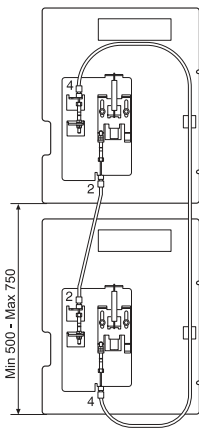

Type B

(emergency interlock below)
Horizontal Vertical

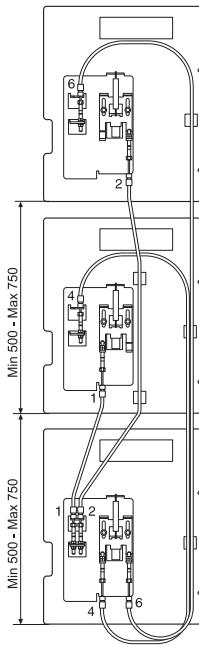

Type B

(emergency interlock in the middle)
Horizontal Vertical

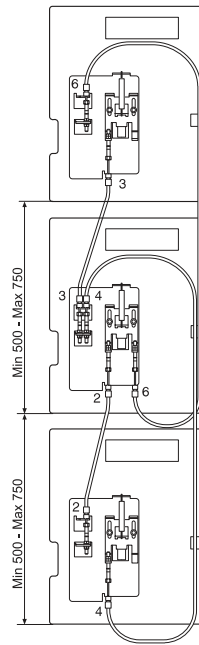

Type B

(emergency interlock above)
Horizontal Vertical

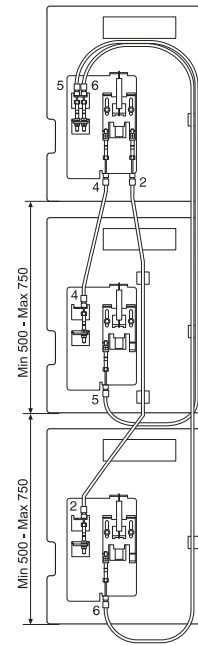

Type C

Horizontal Vertical

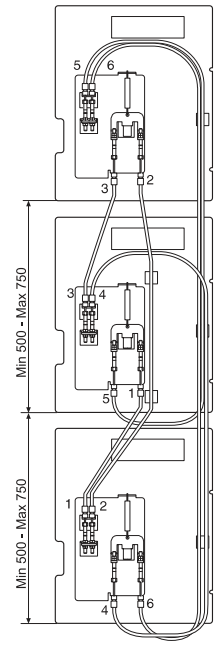

Type D

Horizontal Vertical

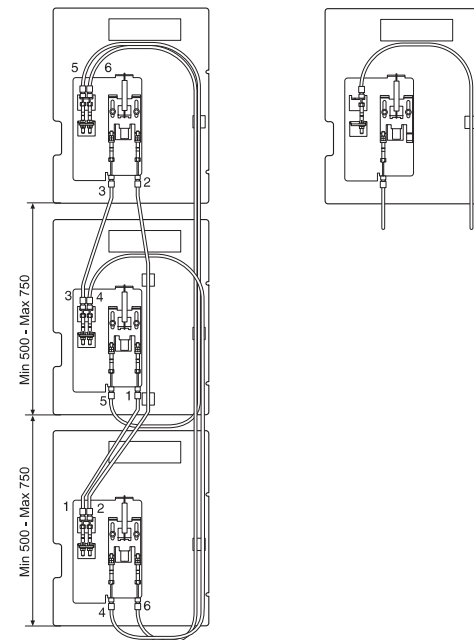

Notes

- When fitting interlocks between two circuit-breakers, it is necessary to make suitable holes (through the switchboard) in the mounting surface for fixed circuit-breakers or for the fixed part of withdrawable circuit-breakers in order to pass through the flexible cables, observing the measurements shown in the figures on pages 7/7 and 7/14.
- For vertical interlocks, align the right-hand sides vertically and reduce the bends in the flexible cables to a minimum (radius R. 70 mm). All the angle values of the bends which the cable passes through added together must not exceed 720°.
- It is possible to make the mechanical interlock among three circuit-breakers disposed in "L position" by using the cables of three horizontal circuit-breakers interlock. Make sure the distance between the horizontal and vertical circuit-breakers respects the minimum and maximum distance.

Horizontal interlocks

Maximum distance between two interlocks 1200 mm from one interlock to the other. The cables pass under the fixed parts, following the same connection layout shown for vertical circuit-breakers.

Extended cables are also available

Mechanical Interlock	Standard cables	Extended cables
HR	1200 mm	1200÷1600 mm
VR	500÷750 mm	750÷1000 mm



Overall dimensions

Circuit-breaker accessories

Mechanical interlock between Emax X1 and Emax E1-E6

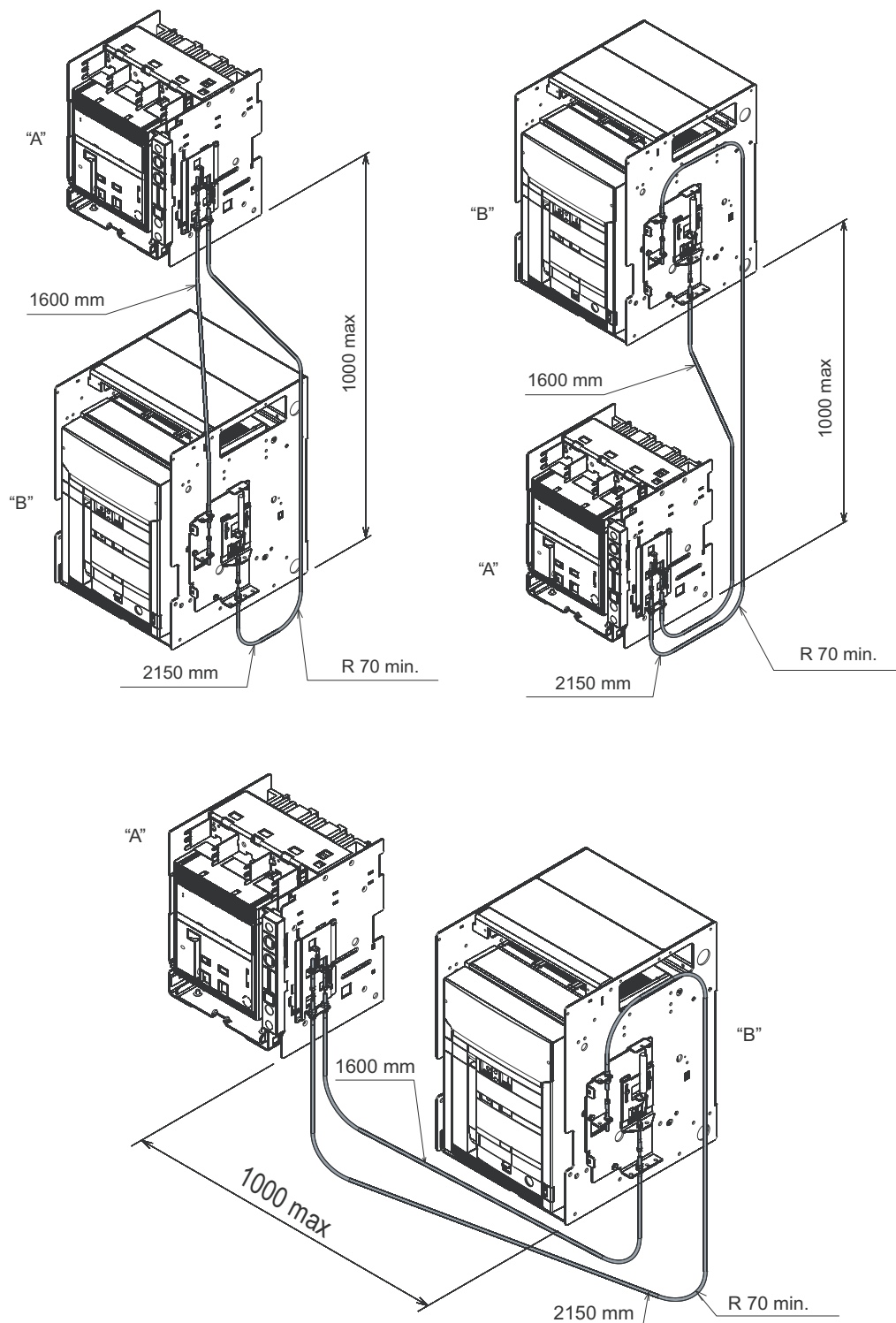

"A" (SX)	"B" (DX)
T7-T7M-X1	E1-E2-E3
E1-E2-E3-E4-E6	T7-T7M-X1

Mechanical compartment door lock

Holes in compartment door

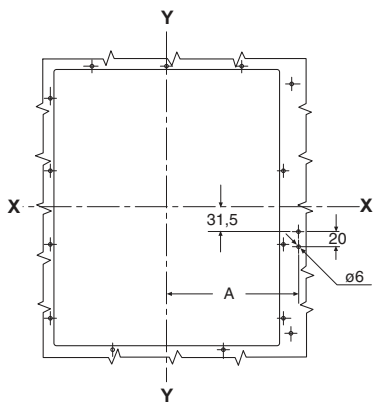

Minimum distance between circuit-breaker and switchboard wall

Fixed version

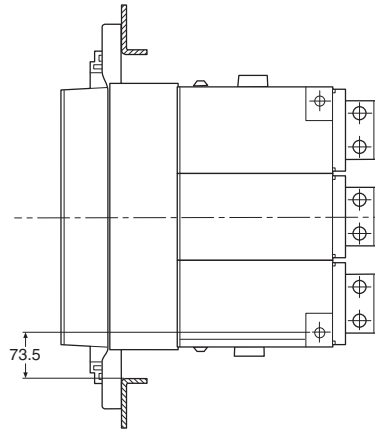

Withdrawable version

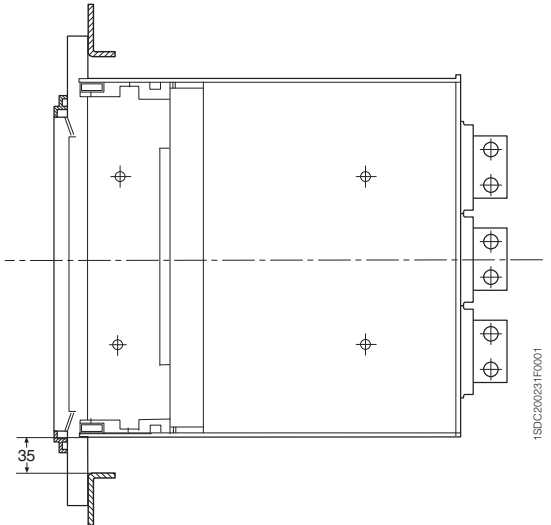

Homopolar toroid

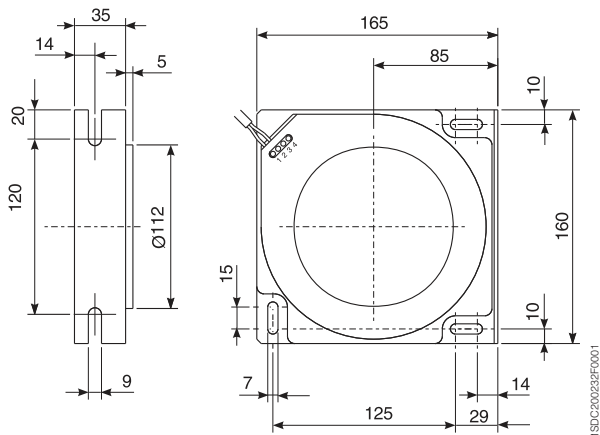

	A	
	3 POLES	4 POLES
E1	180	180
E2	180	180
E3	234	234
E4	270	360
E4/f	-	360
E6	360	486
E6/f	-	486

RC toroid

E1 III - E2 III

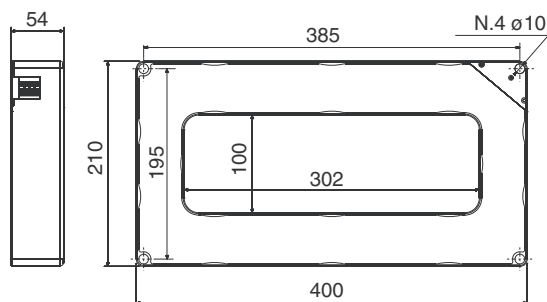

E1 IV - E2 IV - E3 III

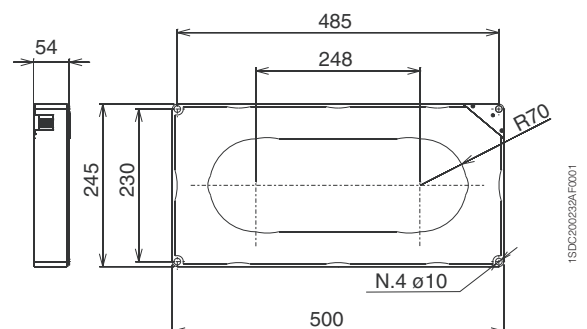

**Electrical signalling
of circuit-breaker
open/closed**

15 supplementary auxiliary contacts

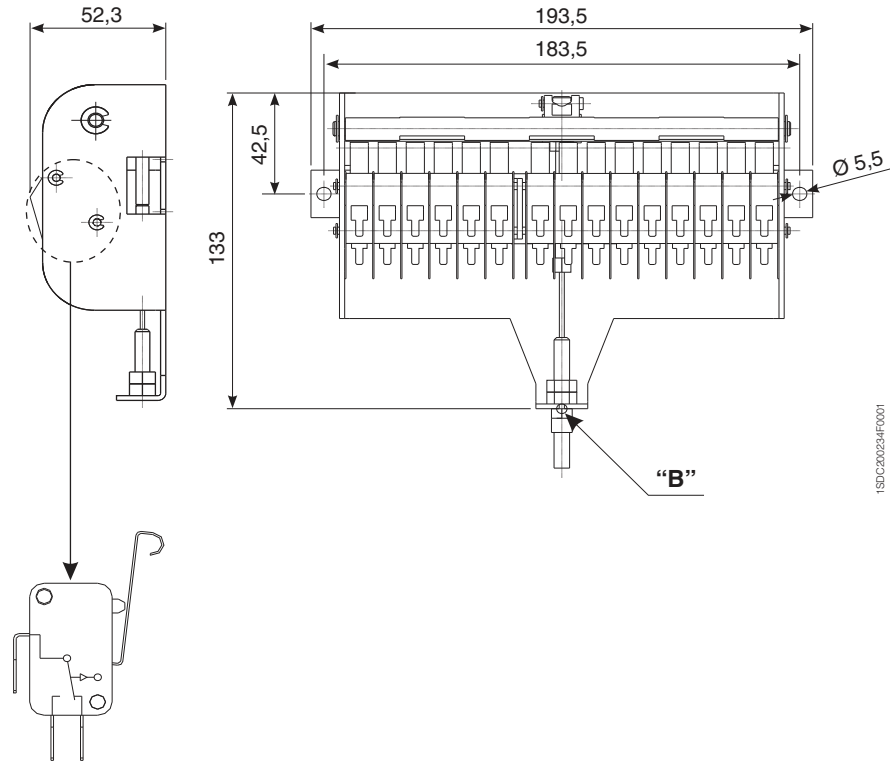

1SD2C20234F0001

A flexible cable 650 mm long is available from point "A" to point "B".

Fixed version

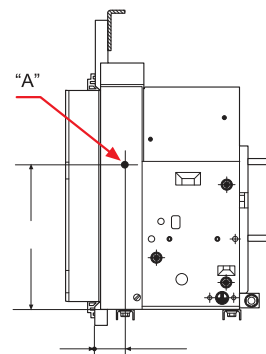

Withdrawable version

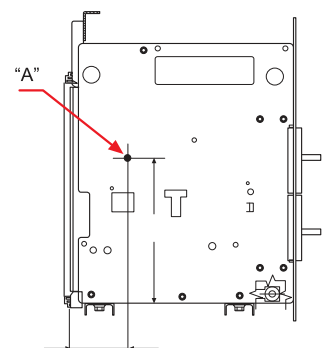

1SD2C20235F0001



Overall dimensions

Circuit-breaker accessories

ATS010

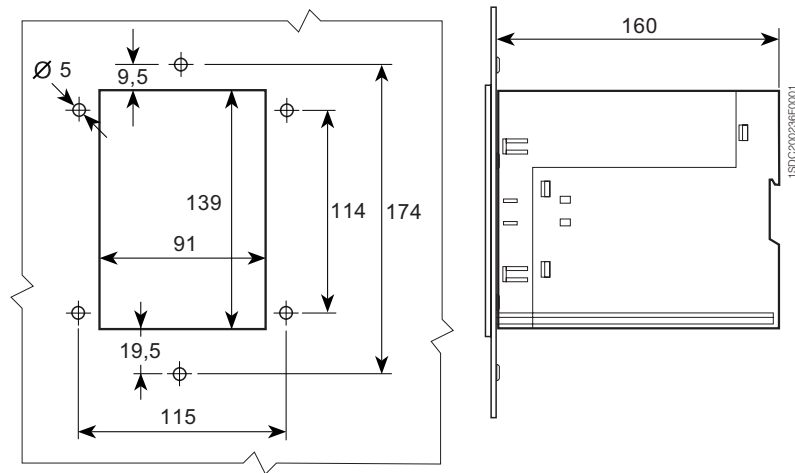

Electronic time-delay device

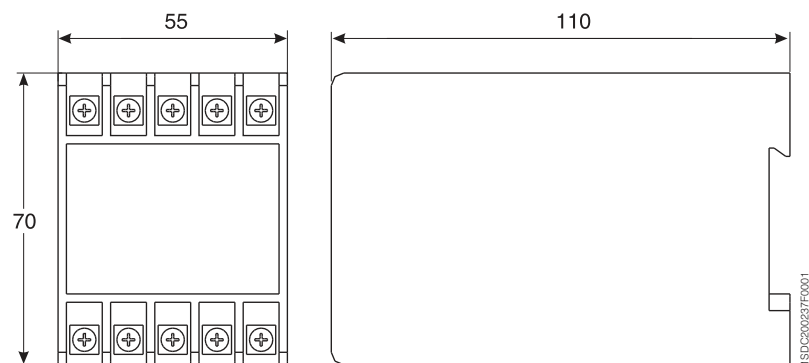

IP54 Protective cover

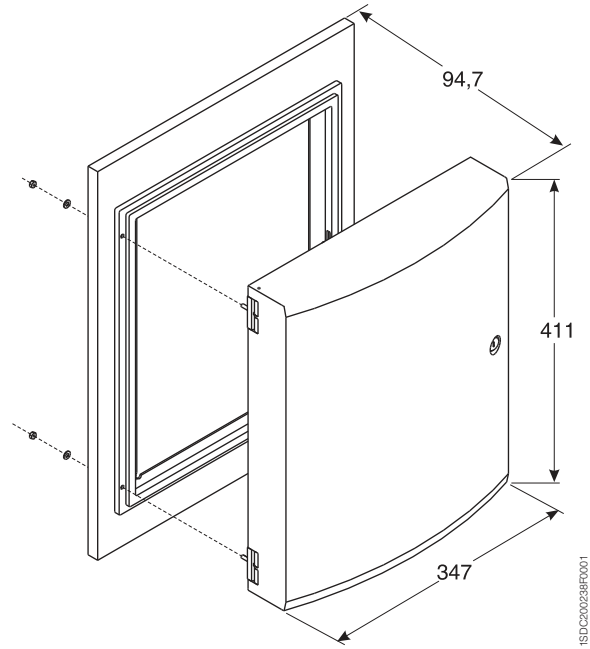

PR021/K Unit

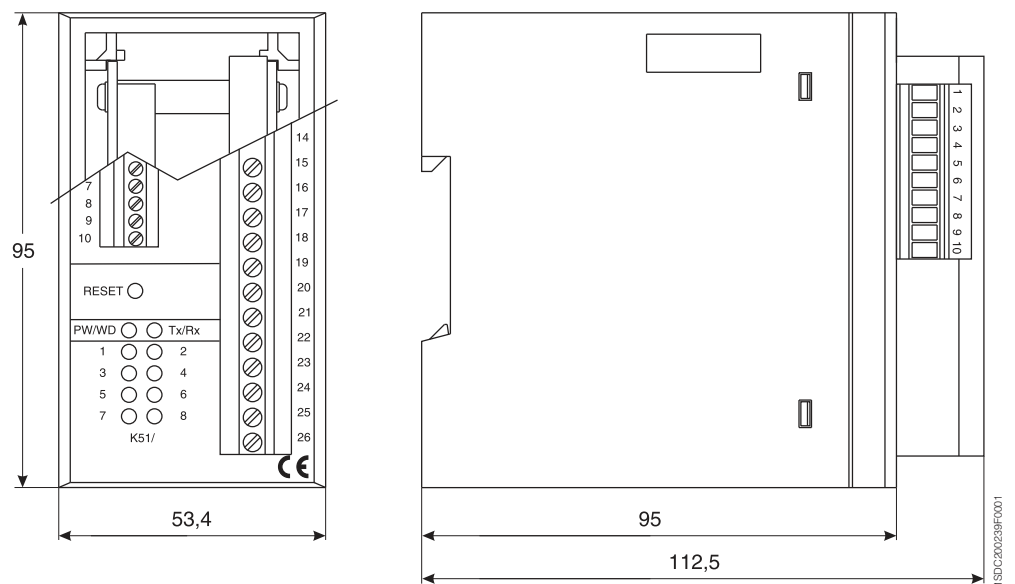

Emmax

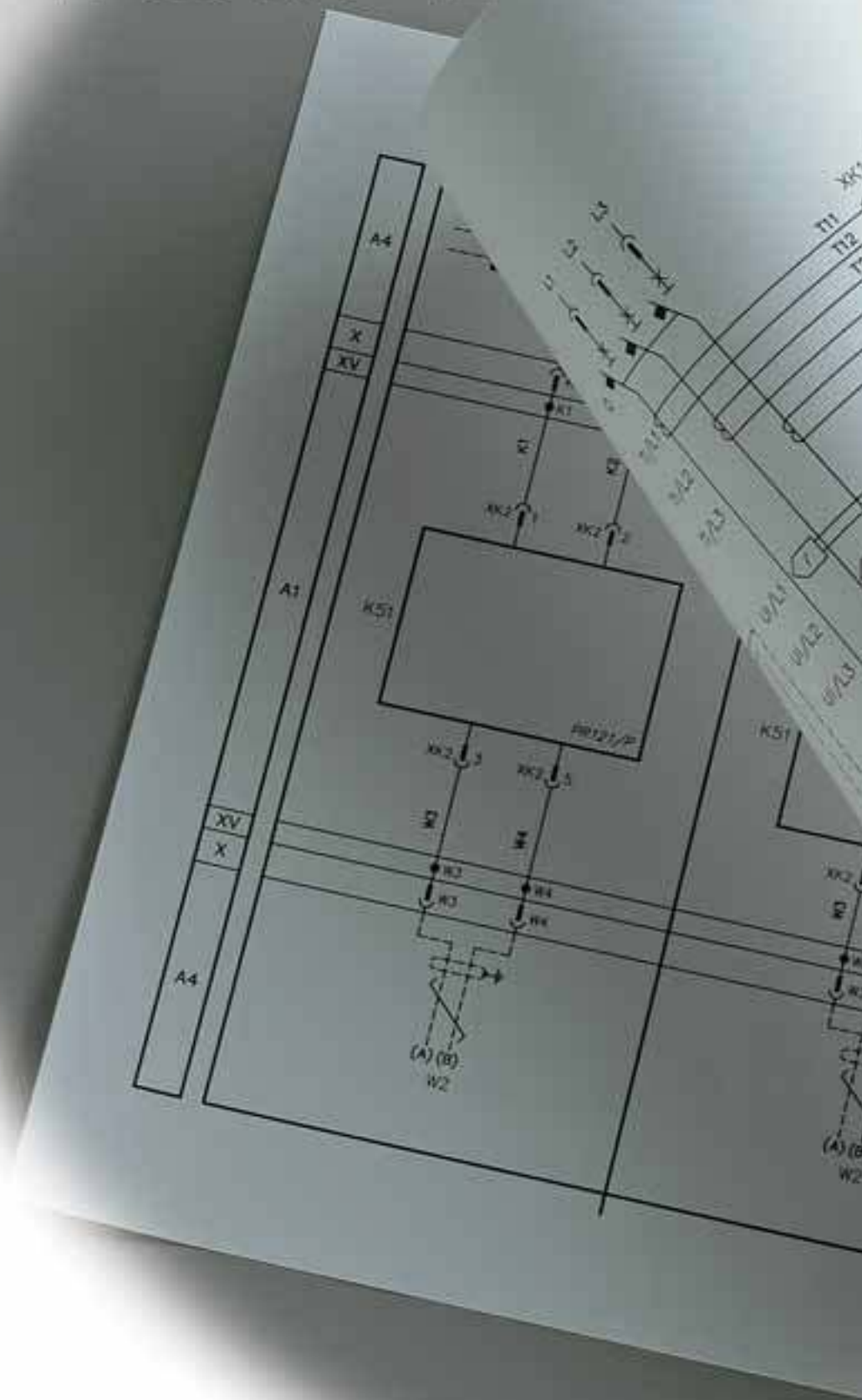

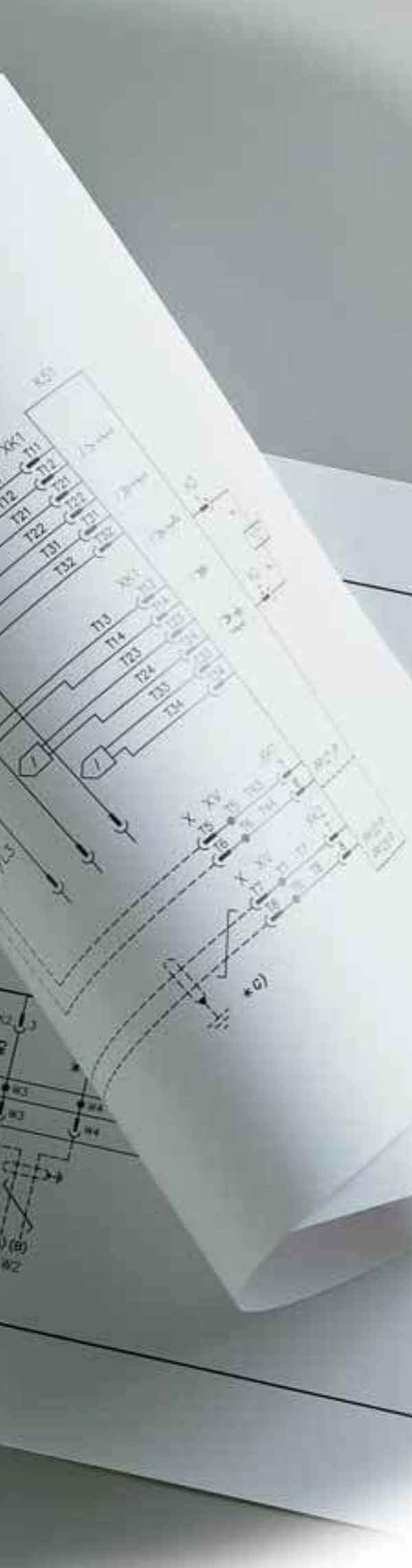

Contents

Reading information - circuit-breakers	8/2
Reading information - Automatic transfer-switch ATS010	8/6
Circuit diagram symbols (IEC 60617 and CEI 3-14 ... 3-26 Standards)	8/7
Circuit diagrams	
Circuit-breakers	8/8
Electrical accessories	8/9
Automatic transfer-switch ATS010	8/14



Circuit diagrams

Reading information - circuit-breakers

Warning

Before installing the circuit-breaker, carefully read notes F and O on the circuit diagrams.

Operating status shown

- The circuit diagram is for the following conditions:
- withdrawable circuit-breaker, open and racked-in
 - circuits de-energised
 - trip units not tripped
 - motor operating mechanism with springs discharged.

Versions

Though the diagram shows a circuit-breaker in withdrawable version, it can be applied to a fixed version circuit-breaker as well.

Fixed version

The control circuits are fitted between terminals XV (connector X is not supplied).
With this version, the applications indicated in figures 31 and 32 cannot be provided.

Withdrawable version

The control circuits are fitted between the poles of connector X (terminal box XV is not supplied).

Version without overcurrent release

With this version, the applications indicated in figures 13, 14, 41, 42, 43, 44, 45, 46, 47 cannot be provided.

Version with PR121/P electronic trip unit

With this version, the applications indicated in figures 42, 43, 44, 45, 46, 47 cannot be provided.

Version with PR122/P electronic trip unit

With this version, the applications indicated in figure 41 cannot be provided.

Version with PR123/P electronic trip unit

With this version, the applications indicated in figure 41 cannot be provided.

Caption

- = Circuit diagram figure number
- * = See note indicated by letter
- A1 = Circuit-breaker accessories
- A3 = Accessories applied to the fixed part of the circuit-breaker (for withdrawable version only)
- A4 = Example switchgear and connections for control and signalling, outside the circuit-breaker
- AY = SOR TEST UNIT Test/monitoring Unit (see note R)
- D = Electronic time-delay device of the undervoltage trip unit, outside the circuit-breaker
- F1 = Delayed-trip fuse
- K51 = PR121, PR122/P, PR123/P electronic trip unit with the following protection functions (see note G):
 - L overload protection with inverse long time-delay trip - setting I1
 - S short-circuit protection with inverse or definite short time-delay trip - setting I2
 - I short-circuit protection with instantaneous time-delay trip - setting I3
 - G earth fault protection with inverse short time-delay trip - setting I4
- K51/1...8 = Contacts of the PR021/K signalling unit
- K51/GZin (DBin) = Zone selectivity: input for protection G or "reverse" direction input for protection D (only with Uaux and PR122/P or PR123/P trip unit)
- K51/GZout (DBout) = Zone selectivity: output for protection G or "reverse" direction output for protection D (only with Uaux and PR122/P or PR123/P trip unit)
- K51/IN1 = Digital programmable input (available only with Uaux and PR122/P or PR123/P trip unit with indicator module PR120/K)
- K51/P1...P4 = Programmable electrical signalling (available only with Uaux and PR122/P or PR123/P trip unit with indicator module PR120/K)
- K51/SZin (DFin) = Zone selectivity: input for protection S or "direct" input for protection D (only with Uaux and PR122/P or PR123/P trip unit)
- K51/SZout (DFout) = Zone selectivity: output for protection S or "direct" output for protection D (only with Uaux and PR122/P or PR123/P trip unit)
- K51/YC = Closing control from PR122/P or PR123/P electronic trip unit with communication module PR120/D-M
- K51/YO = Opening control from PR122/P or PR123/P electronic trip unit with communication module PR120/D-M

M	= Motor for charging the closing springs
Q	= Circuit-breaker
Q/1...27	= Circuit-breaker auxiliary contacts
S33M/1...3	= Limit contacts for spring-charging motor
S43	= Switch for setting remote/local control
S51	= Contact for electrical signalling of circuit-breaker open due to tripping of the overcurrent trip unit. The circuit-breaker may be closed only after pressing the reset pushbutton, or after energizing the coil for electrical reset (if available).
S75E/1...4	= Contacts for electrical signalling of circuit-breaker in racked-out position (only with withdrawable circuit-breakers)
S75I/1...5	= Contacts for electrical signalling of circuit-breaker in racked-in position (only with withdrawable circuit-breakers)
S75T/1...4	= Contacts for electrical signalling of circuit-breaker in test isolated position (only with withdrawable circuit-breakers)
SC	= Pushbutton or contact for closing the circuit-breaker
SO	= Pushbutton or contact for opening the circuit-breaker
SO1	= Pushbutton or contact for opening the circuit-breaker with delayed trip
SO2	= Pushbutton or contact for opening the circuit-breaker with instantaneous trip
SR	= Pushbutton or contact for electrical circuit-breaker reset
TI/L1	= Current transformer located on phase L1
TI/L2	= Current transformer located on phase L2
TI/L3	= Current transformer located on phase L3
Uaux.	= Auxiliary power supply voltage (see note F)
UI/L1	= Current sensor (Rogowski coil) located on phase L1
UI/L2	= Current sensor (Rogowski coil) located on phase L2
UI/L3	= Current sensor (Rogowski coil) located on phase L3
UI/N	= Current sensor (Rogowski coil) located on neutral
UI/O	= Current sensor (Rogowski coil) located on the conductor connecting to earth the star point of the MV/LV transformer (see note G)
W1	= Serial interface with control system (external bus): EIA RS485 interface (see note E)
W2	= Serial interface with the accessories of PR121/P, PR122/P and PR123/P trip units (internal bus)
X	= Delivery connector for auxiliary circuits of withdrawable version circuit-breaker
X1...X7	= Connectors for the accessories of the circuit-breaker
XF	= Delivery terminal box for the position contacts of the withdrawable circuit-breaker (located on the fixed part of the circuit-breaker)
XK1	= Connector for power circuits of PR121/P, PR122/P, and PR123/P trip units
XK2 - XK3	= Connectors for auxiliary circuits of PR121/P, PR122/P and PR123/P trip units
XK4	= Connector signalling open/closed contact
XK5	= Connector for PR120/V module
XO	= Connector for YO1 release
XV	= Delivery terminal box for the auxiliary circuits of the fixed circuit-breaker
YC	= Shunt closing release
YO	= Shunt opening release
YO1	= Overcurrent shunt opening release
YO2	= Second shunt opening release (see note Q)
YR	= Coil to electrically reset the circuit-breaker
YU	= Undervoltage release (see notes B and Q)

Circuit diagrams

Reading information - circuit-breakers

Description of figures

- Fig. 1 = Motor circuit to charge the closing springs.
Fig. 2 = Circuit of shunt closing release.
Fig. 4 = Shunt opening release.
Fig. 6 = Instantaneous undervoltage release (see notes B and Q).
Fig. 7 = Undervoltage trip unit with electronic time-delay device, outside the circuit-breaker (see notes B and Q).
Fig. 8 = Second shunt opening release (see note Q).
Fig. 11 = Contact for electrical signalling of springs charged.
Fig. 12 = Contact for electrical signalling of undervoltage release energized (see notes B and S).
Fig. 13 = Contact for electrical signalling of circuit-breaker open due to tripping of the overcurrent release. The circuit-breaker may be closed only after pressing the reset pushbutton.
Fig. 14 = Contact for electrical signalling of circuit-breaker open due to tripping of the overcurrent release and electrical reset coil. The circuit-breaker may be closed only after pressing the reset pushbutton or energizing the coil.
Fig. 21 = First set of circuit-breaker auxiliary contacts.
Fig. 22 = Second set of circuit-breaker auxiliary contacts (see note V).
Fig. 23 = Third set of supplementary auxiliary contacts outside the circuit-breaker.
Fig. 31 = First set of contacts for electrical signalling of circuit-breaker in racked-in, test isolated, racked-out position.
Fig. 32 = Second set of contacts for electrical signalling of circuit-breaker in racked-in, test isolated, racked-out position.
Fig. 41 = Auxiliary circuits of PR121/P trip unit (see note F).
Fig. 42 = Auxiliary circuits of PR122/P and PR123/P trip units (see notes F, N and V).
Fig. 43 = Circuits of the measuring module PR120/V of the PR122/P and PR123/P trip units internally connected to the circuit-breaker (optional for the trip unit PR122/P) (see notes T and U).
Fig. 44 = Circuits of the measuring module PR120/V of the PR122/P and PR123/P trip units externally connected to the circuit-breaker (optional for the trip unit PR122/P) (see notes O and U).
Fig. 45 = Circuits of the communication module PR120/D-M of the PR122/P and PR123/P trip units (optional) (see note E).
Fig. 46 = Circuits of the indicator module PR120/K of the PR122/P and PR123/P trip units - connection 1 (optional) (see note V).
Fig. 47 = Circuits of the indicator module PR120/K of the PR122/P and PR123/P trip units - connection 2 (optional) (see note V).
Fig. 61 = SOR TEST UNIT Test/monitoring unit (see note R).
Fig. 62 = Circuits of the PR021/K signalling module.

Incompatibilities

The circuits indicated in the following figures cannot be supplied simultaneously on the same circuit-breaker:

- 6 - 7 - 8
- 13 - 14
- 22 - 46 - 47
- 43 - 44

Notes

- A) The circuit-breaker is only fitted with the accessories specified in the ABB SACE order acknowledgement. Consult this catalogue for information on how to make out an order.
- B) The undervoltage release is supplied for operation using a power supply branched on the supply side of the circuit-breaker or from an independent source. The circuit-breaker can only close when the release is energized (there is a mechanical lock on closing).
If the same power supply is used for the closing and undervoltage releases and the circuit-breaker is required to close automatically when the auxiliary power supply comes back on, a 30 ms delay must be introduced between the undervoltage release accept signal and the energizing of the closing trip unit. This may be achieved using an external circuit comprising a permanent make contact, the contact shown in fig. 12 and a time-delay relay.
- E) MODBUS map is available in the 1SDH000556R0001 document
- F) The auxiliary voltage U_{aux} allows actuation of all operations of the PR121/P, PR122/P and PR123/P trip units. Having requested a U_{aux} insulated from earth, one must use "galvanically separated converters" in compliance with IEC 60950 (UL 1950) or equivalent standards that ensure a common mode current or leakage current (see IEC 478/1, CEI 22/3) not greater than 3.5 mA, IEC 60364-41 and CEI 64-8.
- G) Earth fault protection is available with the PR122/P and PR123/P trip units by means of a current sensor located on the conductor connecting to earth the star center of the MV/LV transformer.
The connections between terminals 1 and 2 (or 3) of current transformer UI/O and poles T7 and T8 of the X (or XV) connector must be made with a two-pole shielded and stranded cable (see user manual), no more than 15 m long. The shield must be earthed on the circuit-breaker side and current sensor side.
- N) With PR122/P and PR123/P trip units, the connections to the zone selectivity inputs and outputs must be made with a two-pole shielded and stranded cable (see user manual), no more than 300 m long. The shield must be earthed on the selectivity input side.
- O) Systems with rated voltage of less than 100V or greater than 690V require the use of an insulation voltage transformer to connect to the busbars (connect according to the insertion diagrams provided in the manual).
- P) With PR122/P and PR123/P trip units with communication module PR120/D-M, the power supply for coils YO and YC must not be taken from the main power supply. The coils can be controlled directly from contacts K51/YO and K51/YC with maximum voltages of 110-120 V DC and 240-250 V AC.
- Q) The second opening trip unit may be installed as an alternative to the undervoltage trip unit.
- R) The SACE SOR TEST UNIT + opening release (YO) is guaranteed to operate starting at 75% of the U_{aux} of the opening release itself.
While the YO power supply contact is closing (short-circuit on terminals 4 and 5), the SACE SOR TEST UNIT is unable to detect the opening coil status. Consequently:
- For continuously powered opening coil, the TEST FAILED and ALARM signals will be activated
- If the coil opening command is of the pulsing type, the TEST FAILED signal may appear at the same time. In this case, the TEST FAILED signal is actually an alarm signal only if it remains lit for more than 20s.
- S) Also available in the version with normally-closed contact
- T) The connection between pin 1 of the connector XK5 to the internal neutral conductor is provided by four-pole circuit-breakers, while pin 1 of the connector XK5 is connected to pin T1 of the connector X (or XV) by means of three-pole circuit-breakers.
- U) The measuring module PR120/V is always supplied with relay PR123/P.
- V) If fig. 22 is present (second set of auxiliary contacts) simultaneously as PR122/P or PR123/P trip unit, the contacts for the zone selectivity in fig. 42 (K51/Zin, K51/Zout, K51/Gzin and K51/Gzout) are not wired. In addition, the indicator module PR120/K in figures 46 and 47 cannot be supplied.

Circuit diagrams

Reading information - Automatic transfer switch ATS021 and ATS022

Represented operational state

The diagram represents the following conditions:

- circuit-breakers open and connected #
- circuits de-energised
- closing springs discharged
- overcurrent relays not tripped *

The diagram indicates circuit-breakers in withdrawable version, but it may be applied also to circuit-breakers in fixed version: in this case it's not necessary connect S75I/1 contacts on LOGIC ENABLING input.







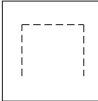
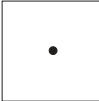
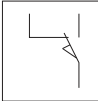
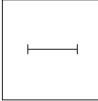
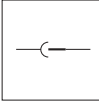
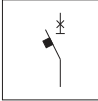

* The diagram indicates circuit-breakers equipped with thermomagnetic overcurrent release but it may be applied also to circuit-breakers without release (switch-disconnectors): in this case it's not necessary connect SY contacts on LOGIC ENABLING input.

Caption

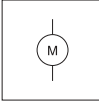
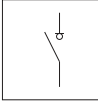
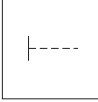
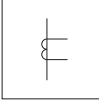
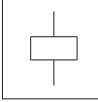
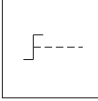
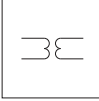
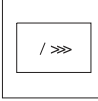
A	= Device type ATS021 and ATS022 for automatic transfer switch of two circuit-breakers
A16	= Solenoid operating mechanism
K1	= Auxiliary contact type VB6-30-01 for the emergency supply voltage presence
K2	= Auxiliary contact type VB6-30-01 for the normal supply voltage presence
Q/1	= Circuit-breaker auxiliary contact
Q1 CB2-E	= Circuit-breaker for emergency supply line
Q2 CB1-N	= Circuit-breaker for normal supply line
Q61/1-2	= Miniature circuit-breaker for auxiliary circuits protection
S75I/1	= Contact signalling circuit-breaker in withdrawable version connected #
SY	= Contact signalling circuit-breaker tripped through releases operation (tripped position) *
X2-XA2	= Connectors for the circuit-breaker auxiliary circuits
XA10	= Connector for the solenoid operating mechanism circuits
XV	= Terminal boards of the accessories

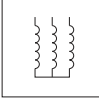
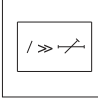
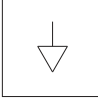
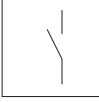
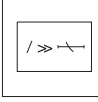
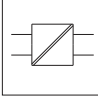
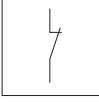
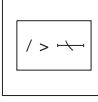
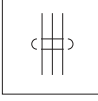
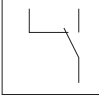
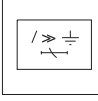
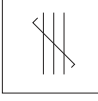
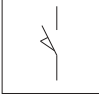
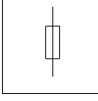
Circuit diagrams

Circuit diagram symbols (IEC 60617 and CEI 3-14 ... 3-26 Standards)

	Shield (may be drawn in any shape)		Terminal		Position switch (limit switch) change-over break before make contact
	Delay		Plug and socket (male and female)		Circuit-breaker-disconnector with automatic trip unit
	Mechanical connection (link)		Motor (general symbol)		Switch-disconnector (on-load isolating switch)
	Manually operated control (general case)		Current transformer		Operating device (general symbol)
	Operated by turning		Voltage transformer		Instantaneous overcurrent or rate-of-rise relay
	Operated by pushing		Winding of three-phase transformer, connection star		Overcurrent relay with adjustable short time-lag characteristic
	Equipotentiality		Make contact		Overcurrent relay with inverse short time-lag characteristic
	Converter with galvanic separator		Break contact		Overcurrent relay with inverse long time-lag characteristic
	Conductors in a screened cable (i.e., 3 conductors shown)		Change-over break before make contact		Earth fault overcurrent relay with inverse short time-lag characteristic
	Twisted conductors (i.e., 3 conductors shown)		Position switch (limit switch), make contact		Fuse (general symbol)
	Connection of conductors		Position switch (limit switch), break contact		Current sensing element

Circuit diagrams

Circuit-breakers

Operating status

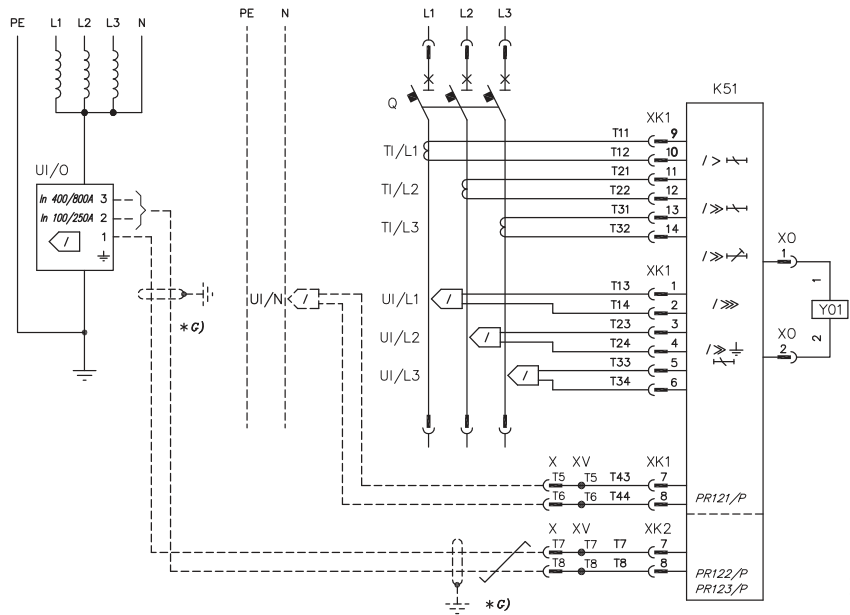

Three-pole circuit-breaker with PR121/P, PR122/P or PR123/P electronic trip unit

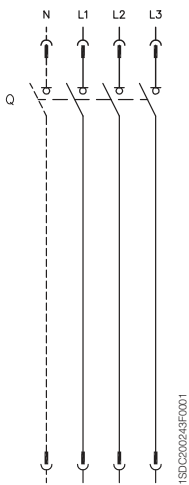

1SDC200244F0001

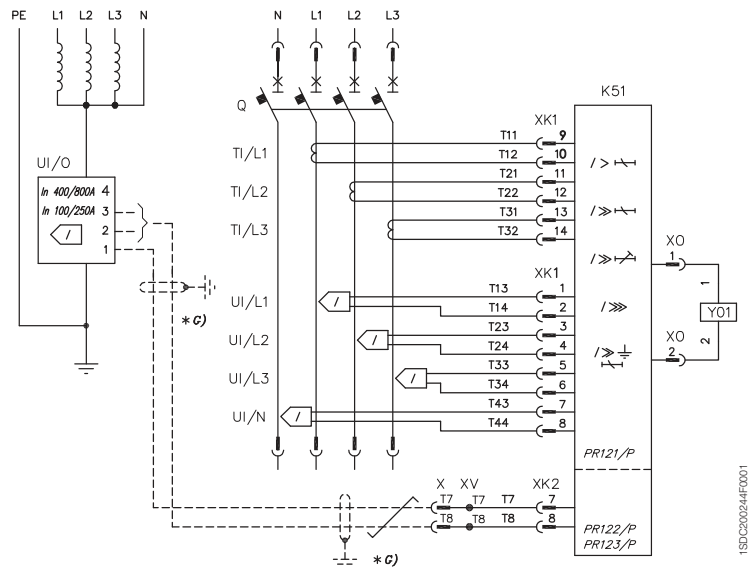

1SDC200244F0001

Four-pole circuit-breaker with PR121/P, PR122/P or PR123/P electronic trip unit

Circuit diagrams

Electrical accessories

Motor operating mechanism, opening, closing and undervoltage releases

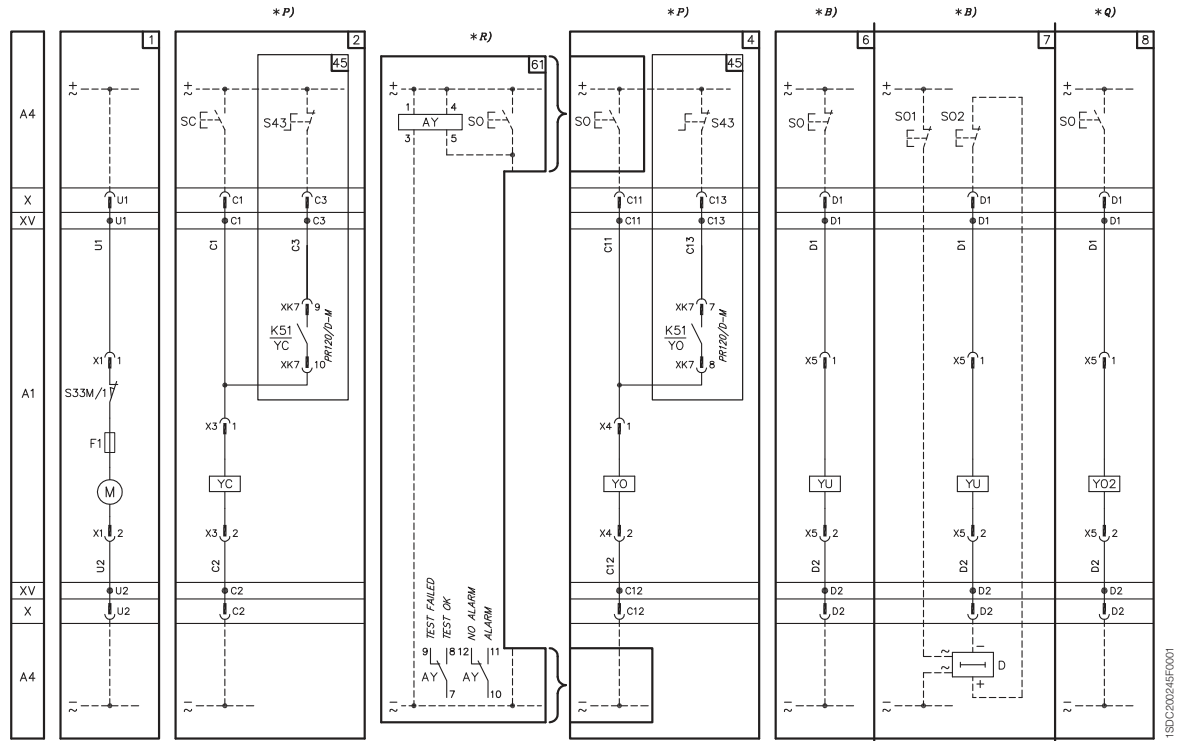

Signalling contacts

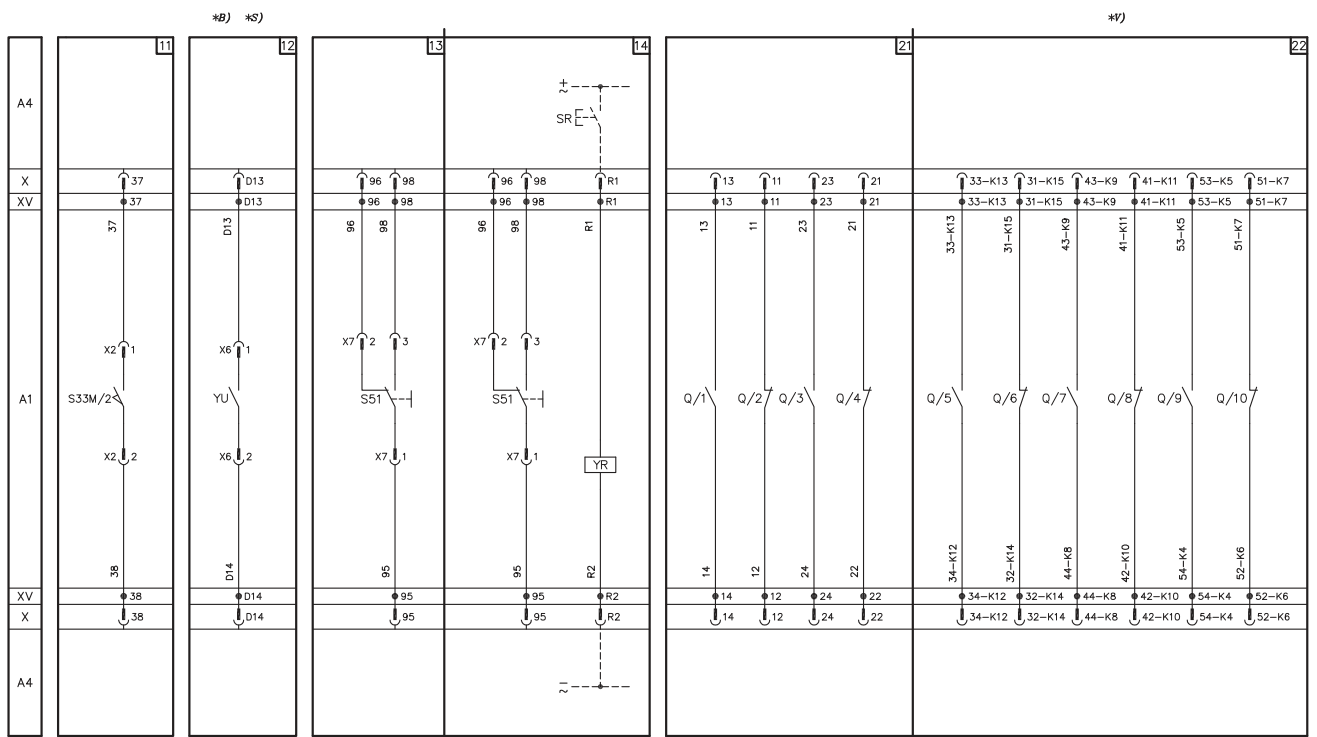

1SDC300246F0001

1SDC300246F0001



Circuit diagrams

Electrical accessories

Signalling contacts

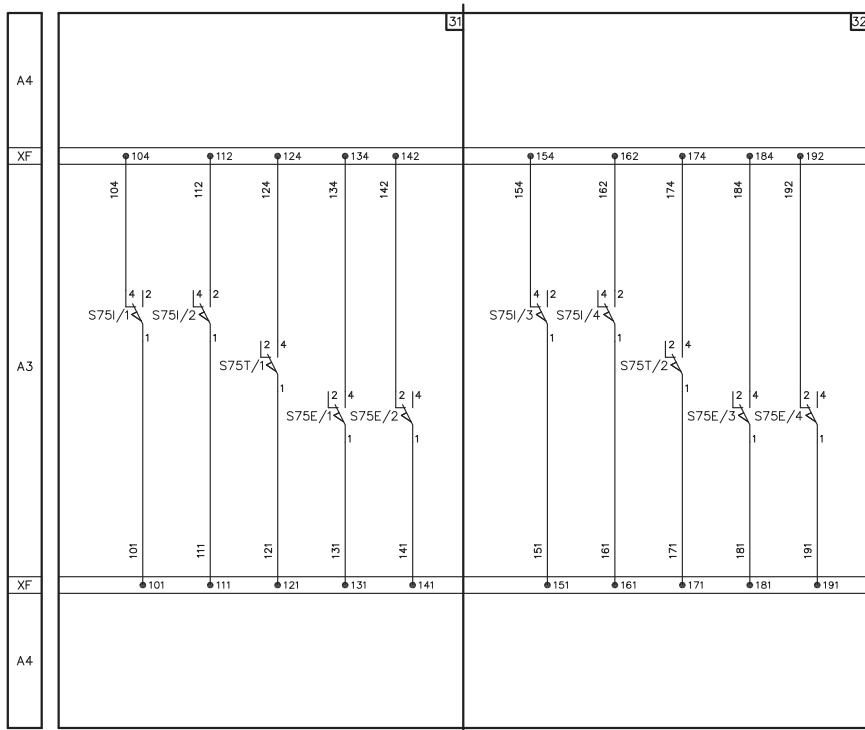
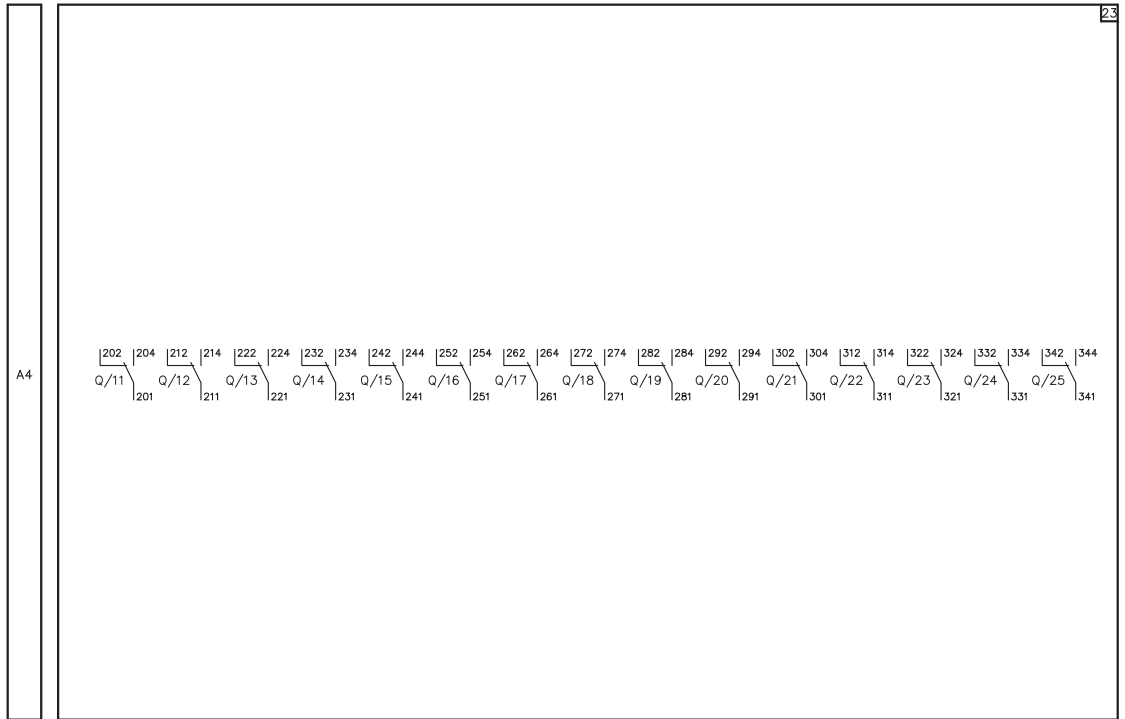

Auxiliary circuits of the PR121, PR122 and PR123 trip units

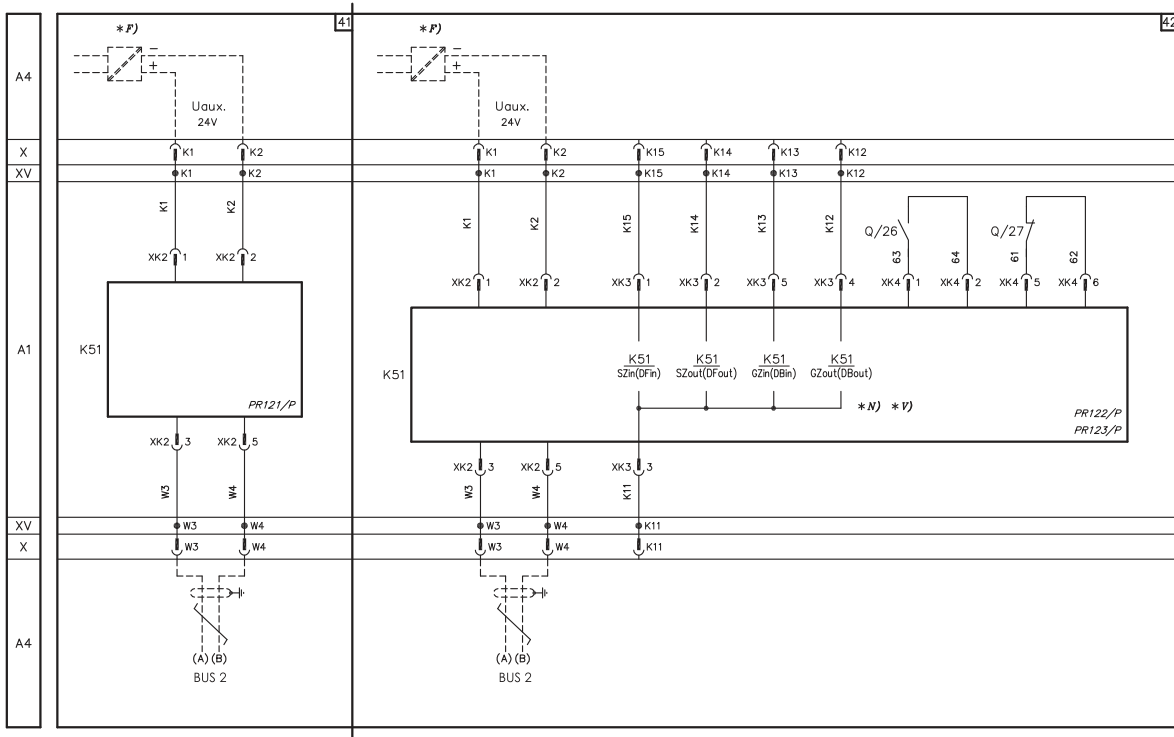

Measuring module PR120/V

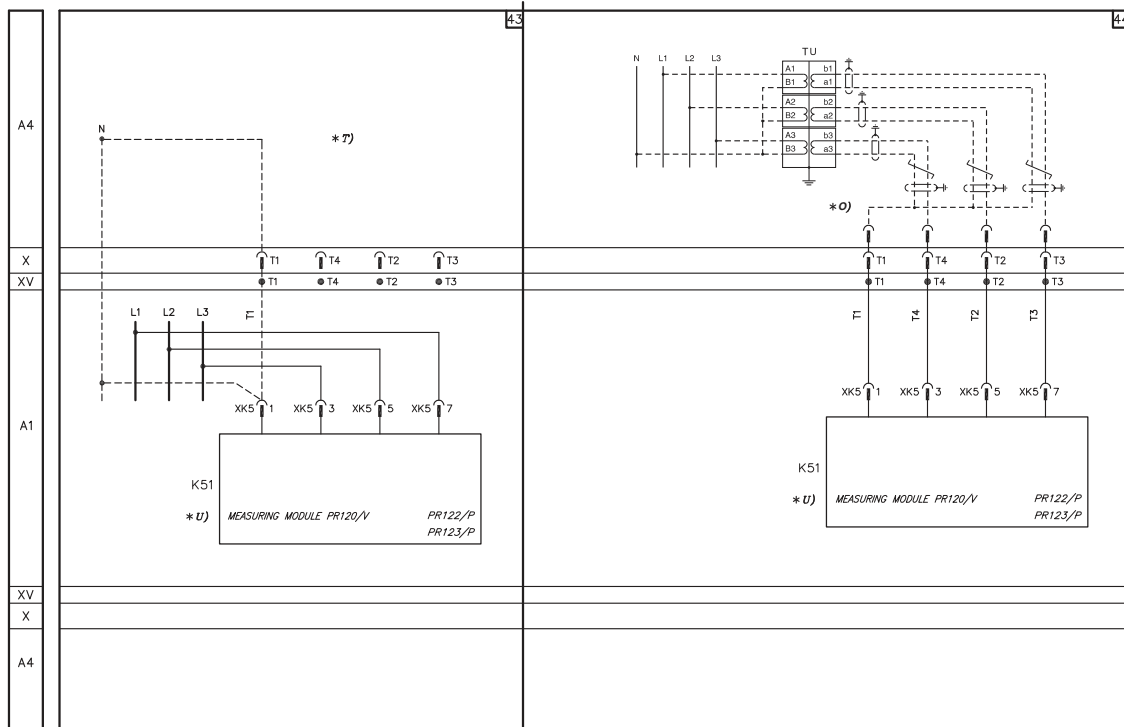

1SDC20226R0001

1SDC20226R0001

Circuit diagrams

Electrical accessories

Communication module PR120/D-M

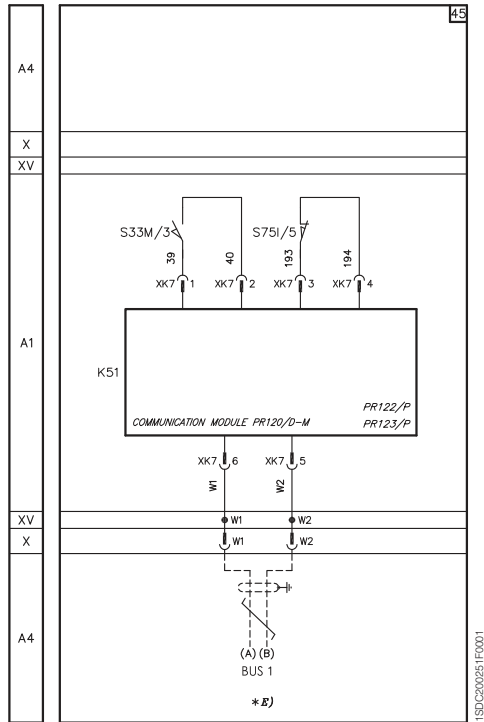

Signalling module PR120/K

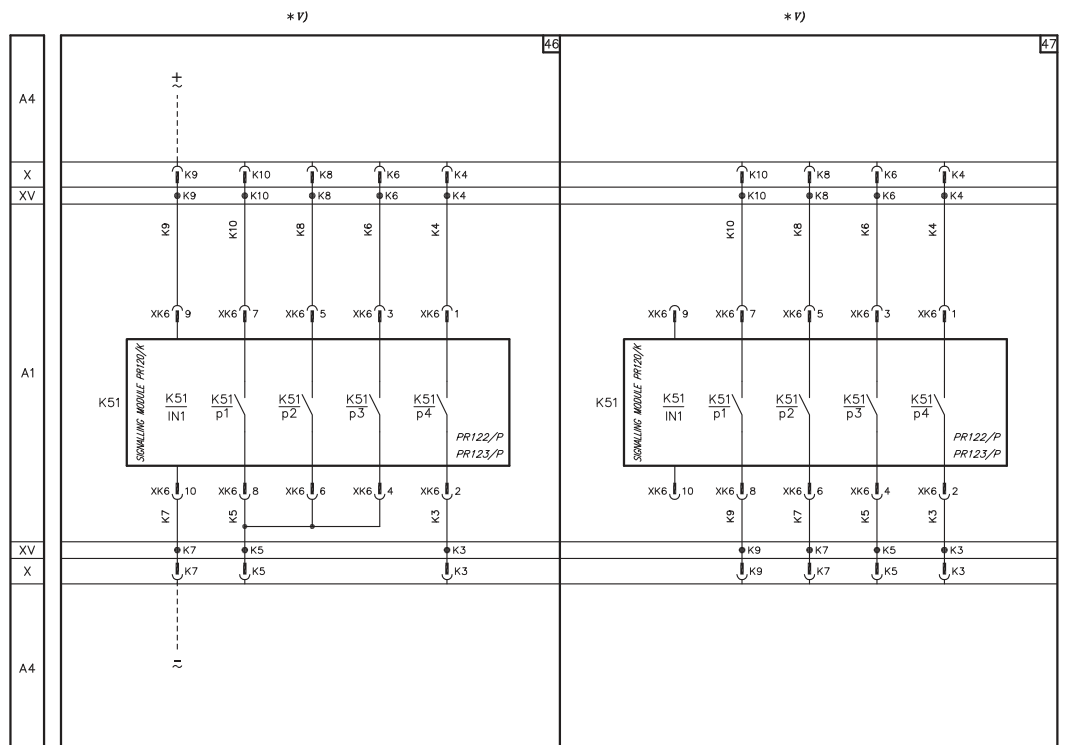

HMI030

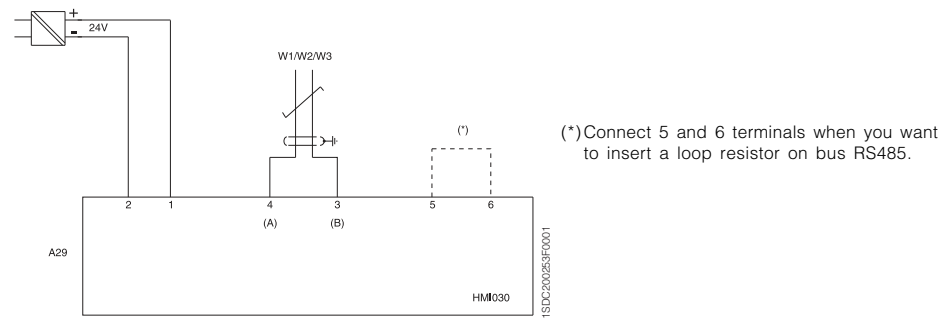

In case of PR222DS/PD and PR223DS/EF, the HMI is connected to the trip unit by means the System bus (W1). When used in association with MM030 as an accessory device, HMI must be connected to accessory bus (W3). Otherwise, local bus (W2) is used.

WITH SAFETY AUXILIARY VOLTAGE SUPPLY

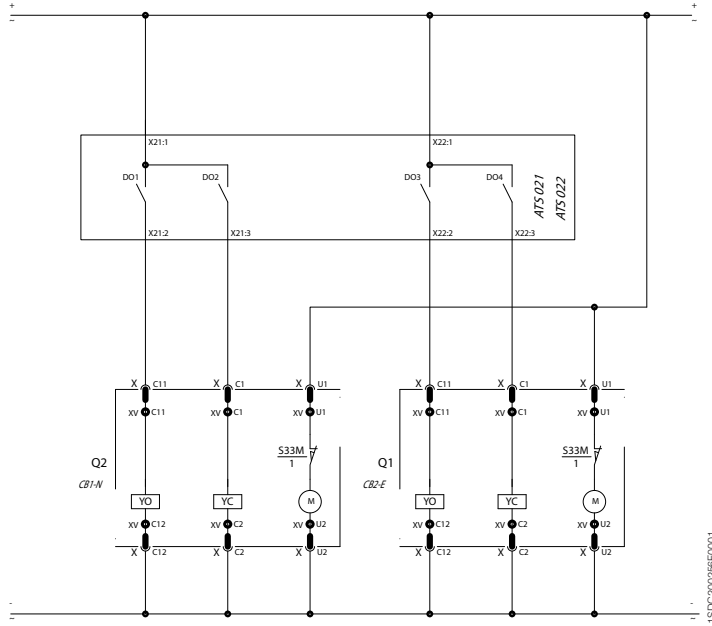

1SDC200257F001

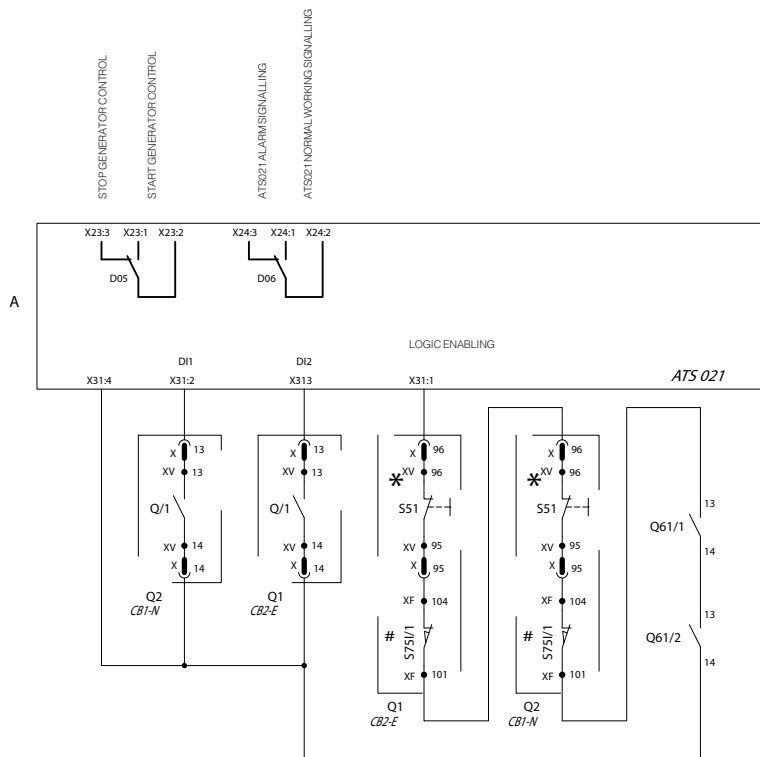

1SDC200257F001

Circuit diagrams

Automatic transfer switch ATS010

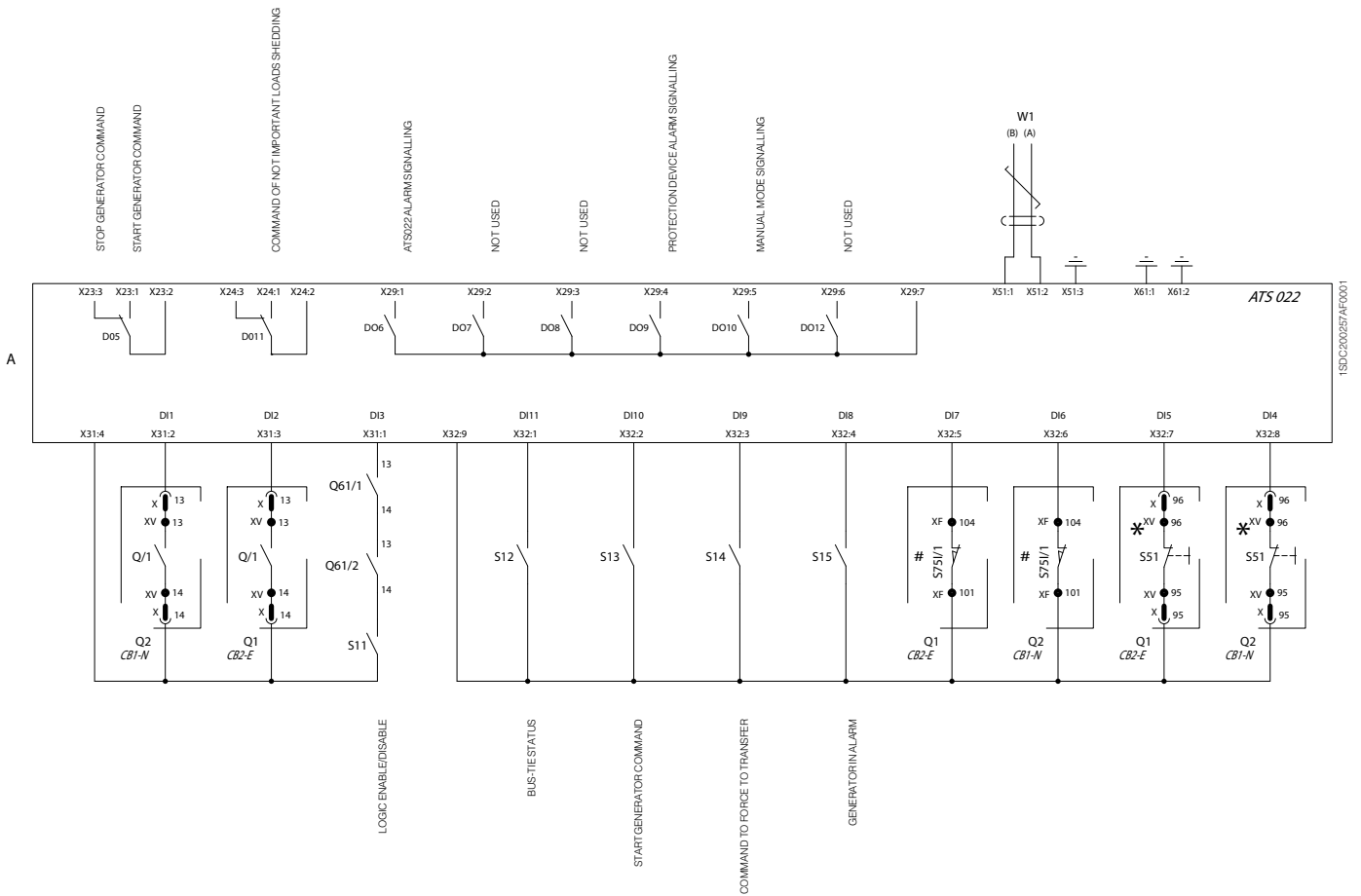

Emmax





Contents

General information	9/2
SACE Emax automatic circuit-breakers	
SACE Emax E1	9/3
SACE Emax E2	9/7
SACE Emax E3	9/11
SACE Emax E4	9/19
SACE Emax E6	9/21
SACE Emax automatic circuit-breakers with full-size neutral conductor	
SACE Emax E4/f	9/23
SACE Emax E6/f	9/24
SACE Emax switch-disconnectors	
SACE Emax E1/MS	9/25
SACE Emax E2/MS	9/27
SACE Emax E3/MS	9/29
SACE Emax E4/MS	9/32
SACE Emax E6/MS	9/33
SACE Emax switch-disconnectors with full-size neutral conductor	
SACE Emax E4/f MS	9/34
SACE Emax E6/f MS	9/35
SACE Emax automatic circuit-breakers for applications up to 1150V AC	
SACE Emax E2/E	9/36
SACE Emax E3/E	9/37
SACE Emax E4/E	9/38
SACE Emax E6/E	9/38
SACE Emax switch-disconnectors for applications up to 1150V AC	
SACE Emax E2/E MS	9/39
SACE Emax E3/E MS	9/40
SACE Emax E4/E MS	9/42
SACE Emax E6/E MS	9/42
SACE Emax switch-disconnectors for applications up to 1000V DC	
SACE Emax E1/E MS	9/43
SACE Emax E2/E MS	9/44
SACE Emax E3/E MS	9/45
SACE Emax E4/E MS	9/46
SACE Emax E6/E MS	9/47
SACE Emax CS sectionalizing trucks	9/48
SACE Emax MTP earthing switches with making capacity	9/49
SACE Emax MT earthing trucks	9/50
SACE Emax FP fixed parts	9/51
Conversion kit for fixed circuit-breaker and fixed parts	9/53
Extra codes	9/54
SACE Emax accessories	9/55
Electronic trip units and current sensors (for loose supplies)	9/62
Order examples	9/63
ABB SACE	9/1



Ordering codes

General information

Abbreviations used in switchgear descriptions

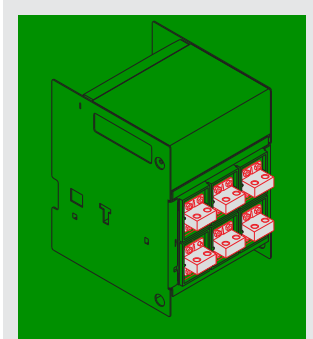

HR = Horizontal rear terminals

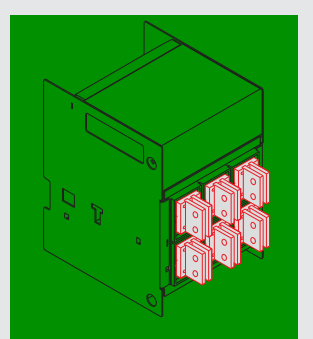

VR = Vertical rear terminals

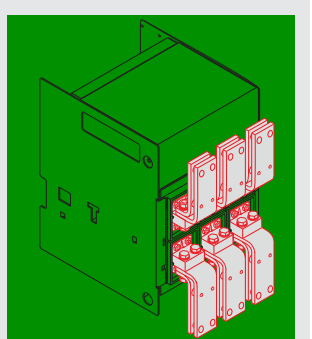

F = Front terminals

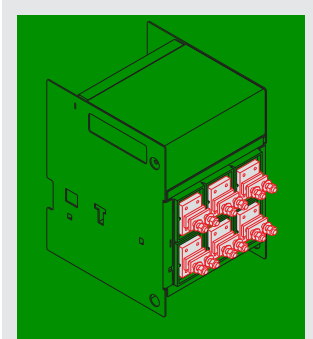

FL = Flat terminals

- F** Fixed
- W** Withdrawable
- MP** Moving part for withdrawable circuit-breakers
- FP** Fixed part for withdrawable circuit-breakers

- PR121/P** PR121/P Electronic trip unit (LI, LSI, LSIG functions)
- PR122/P** PR122/P Electronic trip unit (LSI, LSIG, LSIRc functions)
- PR123/P** PR123/P Electronic trip unit (LSIG functions)

Functions:

- L** Protection against overload with long inverse time-delay trip
- S** Selective protection against short-circuit with short inverse or definite time-delay trip
- I** Protection against instantaneous short-circuit with adjustable trip current threshold
- G** Protection against earth faults
- Rc** Protection against residual current earth faults

- Iu** Rated uninterrupted current of the circuit-breaker
- In** Rated current of the electronic release current transformers
- Icu** Rated ultimate short-circuit breaking capacity
- Icw** Rated short-time withstand current
- AC** AC applications
- DC** DC applications

- /MS** Switch-disconnector
- /E** Automatic circuit-breaker for applications up to 1150 V
- /E MS** Switch-disconnector for applications up to 1150 V AC and 1000 V DC
- CS** Sectionalizing truck
- MTP** Earthing switch
- MT** Earthing truck

Ordering codes

SACE Emax automatic circuit-breakers

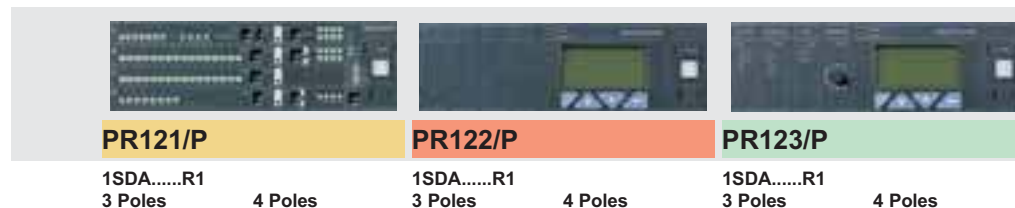
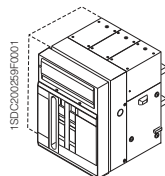

PR121/P **PR122/P** **PR123/P**

1SDA.....R1
3 Poles

4 Poles

1SDA.....R1
3 Poles

4 Poles

1SDA.....R1
3 Poles

4 Poles

E1B 08

Fixed (F)

I_{cu} (415 V) = 42 kA I_{cw} (1 s) = 42 kA

HR = Horizontal rear terminals

LI	055600	055608	055603	055611		
LSI	055601	055609	055604	055612	055606	055614
LSIG	055602	055610	055605	055613	055607	055615
LSIRc*			058553	058555		

* to be ordered with toroid for residual current protection (see code on page 9/58)

E1N 08

Fixed (F)

I_{cu} (415 V) = 50 kA I_{cw} (1 s) = 50 kA

HR = Horizontal rear terminals

LI	055696	055704	055699	055707		
LSI	055697	055705	055700	055708	055702	055710
LSIG	055698	055706	055701	055709	055703	055711
LSIRc*			058577	058579		

* to be ordered with toroid for residual current protection (see code on page 9/58)

E1B 10

Fixed (F)

I_{cu} (415 V) = 42 kA I_{cw} (1 s) = 42 kA

HR = Horizontal rear terminals

LI	059169	059171	059181	059183		
LSI	059173	059175	059185	059187	059197	059199
LSIG	059177	059179	059189	059191	059201	059203

E1N 10

Fixed (F)

I_{cu} (415 V) = 50 kA I_{cw} (1 s) = 50 kA

HR = Horizontal rear terminals

LI	059213	059215	059225	059227		
LSI	059217	059219	059229	059231	059241	059243
LSIG	059221	059223	059233	059235	059245	059247

E1B 12

Fixed (F)

I_{cu} (415 V) = 42 kA I_{cw} (1 s) = 42 kA

HR = Horizontal rear terminals

LI	055632	055640	055635	055643		
LSI	055633	055641	055636	055644	055638	055646
LSIG	055634	055642	055637	055645	055639	055647
LSIRc*			058561	058563		

* to be ordered with toroid for residual current protection (see code on page 9/58)

E1N 12

Fixed (F)

I_{cu} (415 V) = 50 kA I_{cw} (1 s) = 50 kA

HR = Horizontal rear terminals

LI	055728	055736	055731	055739		
LSI	055729	055737	055732	055740	055734	055742
LSIG	055730	055738	055733	055741	055735	055743
LSIRc*			058585	058587		

* to be ordered with toroid for residual current protection (see code on page 9/58)



Ordering codes

SACE Emax automatic circuit-breakers

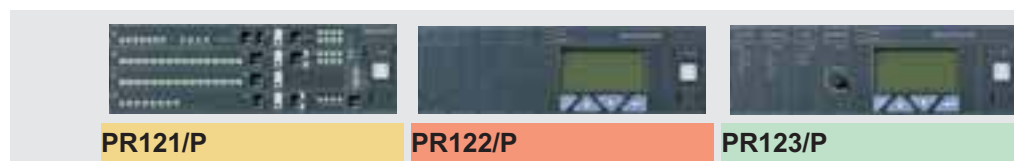
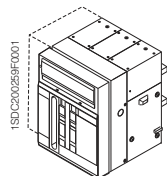

PR121/P

1SDA.....R1
3 Poles 4 Poles

PR122/P

1SDA.....R1
3 Poles 4 Poles

PR123/P

1SDA.....R1
3 Poles 4 Poles

E1B 16

Fixed (F)

Icu (415 V) = **42 kA** Icw (1 s) = **42 kA**

HR = Horizontal rear terminals

LI	055664	055672	055667	055675		
LSI	055665	055673	055668	055676	055670	055678
LSIG	055666	055674	055669	055677	055671	055679

E1N 16

Fixed (F)

Icu (415 V) = **50 kA** Icw (1 s) = **50 kA**

HR = Horizontal rear terminals

LI	055760	055768	055763	055771		
LSI	055761	055769	055764	055772	055766	055774
LSIG	055762	055770	055765	055773	055767	055775

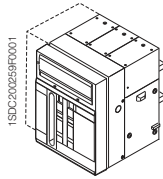

E1B 08

Withdrawable (W) - MP

Icu (415 V) = 42 kA Icw (1 s) = 42 kA

MP = Moving part						
LI	055616	055624	055619	055627		
LSI	055617	055625	055620	055628	055622	055630
LSIG	055618	055626	055621	055629	055623	055631
LSIRc*			058557	058559		

* to be ordered with toroid for residual current protection (see code on page 9/58)

E1N 08

Withdrawable (W) - MP

Icu (415 V) = 50 kA Icw (1 s) = 50 kA

MP = Moving part						
LI	055712	055720	055715	055723		
LSI	055713	055721	055716	055724	055718	055726
LSIG	055714	055722	055717	055725	055719	055727
LSIRc*			058581	058583		

* to be ordered with toroid for residual current protection (see code on page 9/58)

E1B 10

Withdrawable (W) - MP

Icu (415 V) = 42 kA Icw (1 s) = 42 kA

MP = Moving part						
LI	059170	059172	059182	059184		
LSI	059174	059176	059186	059188	059198	059200
LSIG	059178	059180	059190	059192	059202	059204

E1N 10

Withdrawable (W) - MP

Icu (415 V) = 50 kA Icw (1 s) = 50 kA

MP = Moving part						
LI	059214	059216	059226	059228		
LSI	059218	059220	059230	059232	059242	059244
LSIG	059222	059224	059234	059236	059246	059248

E1B 12

Withdrawable (W) - MP

Icu (415 V) = 42 kA Icw (1 s) = 42 kA

MP = Moving part						
LI	055648	055656	055651	055659		
LSI	055649	055657	055652	055660	055654	055662
LSIG	055650	055658	055653	055661	055655	055663
LSIRc*			058565	058567		

* to be ordered with toroid for residual current protection (see code on page 9/58)

E1N 12

Withdrawable (W) - MP

Icu (415 V) = 50 kA Icw (1 s) = 50 kA

MP = Moving part						
LI	055744	055752	055747	055755		
LSI	055745	055753	055748	055756	055750	055758
LSIG	055746	055754	055749	055757	055751	055759
LSIRc*			058589	058591		

* to be ordered with toroid for residual current protection (see code on page 9/58)



Ordering codes

SACE Emax automatic circuit-breakers

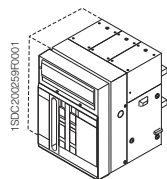

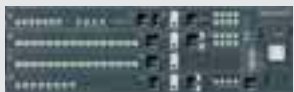
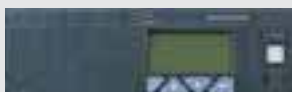
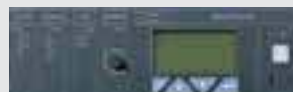
		
PR121/P	PR122/P	PR123/P
1SDA.....R1 3 Poles	1SDA.....R1 3 Poles	1SDA.....R1 3 Poles
4 Poles	4 Poles	4 Poles

E1B 16

Withdrawable (W) - MP

Icu (415 V) = **42 kA** Icw (1 s) = **42 kA**

MP = Moving part						
LI	055680	055688	055683	055691		
LSI	055681	055689	055684	055692	055686	055694
LSIG	055682	055690	055685	055693	055687	055695

E1N 16

Withdrawable (W) - MP

Icu (415 V) = **50 kA** Icw (1 s) = **50 kA**

MP = Moving part						
LI	055776	055784	055779	055787		
LSI	055777	055785	055780	055788	055782	055790
LSIG	055778	055786	055781	055789	055783	055791

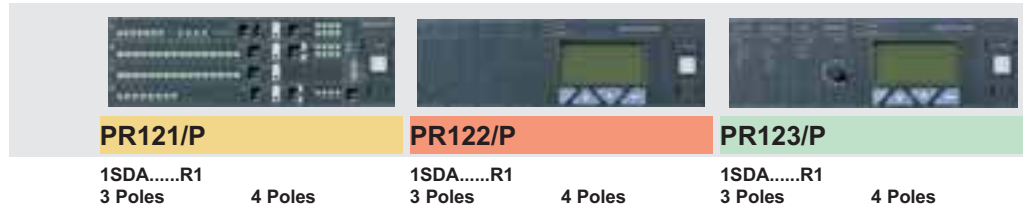
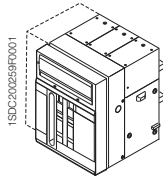

E2S 08

Fixed (F)

Icu (415 V) = 85 kA Icw (1 s) = 65 kA

HR = Horizontal rear terminals

LI	058282	058290	058285	058293		
LSI	058283	058291	058286	058294	058288	058296
LSIG	058284	058292	058287	058295	058289	058297
LSIRc*			058657	058659		

* to be ordered with toroid for residual current protection (see code on page 9/58)

E2N 10

Fixed (F)

Icu (415 V) = 65 kA Icw (1 s) = 55 kA

HR = Horizontal rear terminals

LI	059257	059259	059269	059271		
LSI	059261	059263	059273	059275	059285	059287
LSIG	059265	059267	059277	059279	059289	059291

E2S 10

Fixed (F)

Icu (415 V) = 85 kA Icw (1 s) = 65 kA

HR = Horizontal rear terminals

LI	059301	059303	059313	059315		
LSI	059305	059307	059317	059319	059329	059331
LSIG	059309	059311	059321	059323	059333	059335

E2N 12

Fixed (F)

Icu (415 V) = 65 kA Icw (1 s) = 55 kA

HR = Horizontal rear terminals

LI	055856	055864	055859	055867		
LSI	055857	055865	055860	055868	055862	055870
LSIG	055858	055866	055861	055869	055863	055871
LSIRc*			058633	058635		

* to be ordered with toroid for residual current protection (see code on page 9/58)

E2S 12

Fixed (F)

Icu (415 V) = 85 kA Icw (1 s) = 65 kA

HR = Horizontal rear terminals

LI	055952	055960	055955	055963		
LSI	055953	055961	055956	055964	055958	055966
LSIG	055954	055962	055957	055965	055959	055967
LSIRc*			058665	058667		

* to be ordered with toroid for residual current protection (see code on page 9/58)

E2L 12

Fixed (F)

Icu (415 V) = 130 kA Icw (1 s) = 10 kA

HR = Horizontal rear terminals

LI	056048	056056	056051	056059		
LSI	056049	056057	056052	056060	056054	056062
LSIG	056050	056058	056053	056061	056055	056063
LSIRc*			058617	058619		

* to be ordered with toroid for residual current protection (see code on page 9/58)

E2B 16

Fixed (F)

Icu (415 V) = 42 kA Icw (1 s) = 42 kA

HR = Horizontal rear terminals

LI	055792	055800	055795	055803		
LSI	055793	055801	055796	055804	055798	055806
LSIG	055794	055802	055797	055805	055799	055807



Ordering codes

SACE Emax automatic circuit-breakers

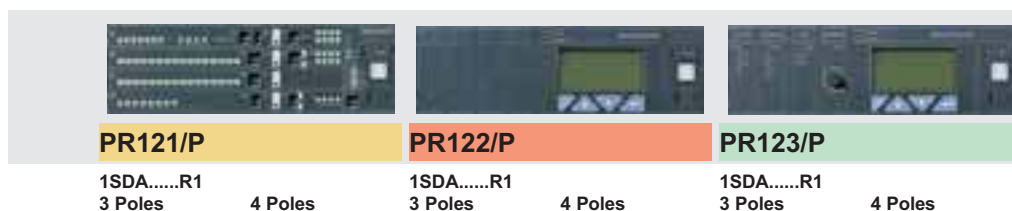
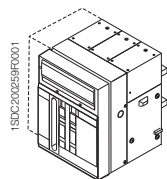

E2N 16

Fixed (F)

Icu (415 V) = **65 kA** Icw (1 s) = **55 kA**

HR = Horizontal rear terminals

LI	055888	055896	055891	055899		
LSI	055889	055897	055892	055900	055894	055902
LSIG	055890	055898	055893	055901	055895	055903

E2S 16

Fixed (F)

Icu (415 V) = **85 kA** Icw (1 s) = **65 kA**

HR = Horizontal rear terminals

LI	055984	055992	055987	055995		
LSI	055985	055993	055988	055996	055990	055998
LSIG	055986	055994	055989	055997	055991	055999

E2L 16

Fixed (F)

Icu (415 V) = **130 kA** Icw (1 s) = **10 kA**

HR = Horizontal rear terminals

LI	056080	056088	056083	056091		
LSI	056081	056089	056084	056092	056086	056094
LSIG	056082	056090	056085	056093	056087	056095

E2B 20

Fixed (F)

Icu (415 V) = **42 kA** Icw (1 s) = **42 kA**

HR = Horizontal rear terminals

LI	055824	055832	055827	055835		
LSI	055825	055833	055828	055836	055830	055838
LSIG	055826	055834	055829	055837	055831	055839
LSIRc*			058609	058611		

* to be ordered with toroid for residual current protection (see code on page 9/58)

E2N 20

Fixed (F)

Icu (415 V) = **65 kA** Icw (1 s) = **55 kA**

HR = Horizontal rear terminals

LI	055920	055928	055923	055931		
LSI	055921	055929	055924	055932	055926	055934
LSIG	055922	055930	055925	055933	055927	055935
LSIRc*			058649	058651		

* to be ordered with toroid for residual current protection (see code on page 9/58)

E2S 20

Fixed (F)

Icu (415 V) = **85 kA** Icw (1 s) = **65 kA**

HR = Horizontal rear terminals

LI	056016	056024	056019	056027		
LSI	056017	056025	056020	056028	056022	056030
LSIG	056018	056026	056021	056029	056023	056031
LSIRc*			058681	058683		

* to be ordered with toroid for residual current protection (see code on page 9/58)

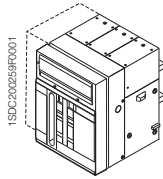

E2S 08

Withdrawable (W) - MP

Icu (415 V) = 85 kA Icw (1 s) = 65 kA

MP = Moving part

LI	058298	058306	058301	058309		
LSI	058299	058307	058302	058310	058304	058312
LSIG	058300	058308	058303	058311	058305	058313
LSIRc*			058661	058663		

* to be ordered with toroid for residual current protection (see code on page 9/58)

E2N 10

Withdrawable (W) - MP

Icu (415 V) = 65 kA Icw (1 s) = 55 kA

MP = Moving part

LI	059258	059260	059270	059272		
LSI	059262	059264	059274	059276	059286	059288
LSIG	059266	059268	059278	059280	059290	059292

E2S 10

Withdrawable (W) - MP

Icu (415 V) = 85 kA Icw (1 s) = 65 kA

MP = Moving part

LI	059302	059304	059314	059316		
LSI	059306	059308	059318	059320	059330	059332
LSIG	059310	059312	059322	059324	059334	059336

E2N 12

Withdrawable (W) - MP

Icu (415 V) = 65 kA Icw (1 s) = 55 kA

MP = Moving part

LI	055872	055880	055875	055883		
LSI	055873	055881	055876	055884	055878	055886
LSIG	055874	055882	055877	055885	055879	055887
LSIRc*			058637	058639		

* to be ordered with toroid for residual current protection (see code on page 9/58)

E2S 12

Withdrawable (W) - MP

Icu (415 V) = 85 kA Icw (1 s) = 65 kA

MP = Moving part

LI	055968	055976	055971	055979		
LSI	055969	055977	055972	055980	055974	055982
LSIG	055970	055978	055973	055981	055975	055983
LSIRc*			058669	058671		

* to be ordered with toroid for residual current protection (see code on page 9/58)

E2L 12

Withdrawable (W) - MP

Icu (415 V) = 130 kA Icw (1 s) = 10 kA

MP = Moving part

LI	056064	056072	056067	056075		
LSI	056065	056073	056068	056076	056070	056078
LSIG	056066	056074	056069	056077	056071	056079
LSIRc*			058621	058623		

* to be ordered with toroid for residual current protection (see code on page 9/58)

E2B 16

Withdrawable (W) - MP

Icu (415 V) = 42 kA Icw (1 s) = 42 kA

MP = Moving part

LI	055808	055816	055811	055819		
LSI	055809	055817	055812	055820	055814	055822
LSIG	055810	055818	055813	055821	055815	055823



Ordering codes

SACE Emax automatic circuit-breakers

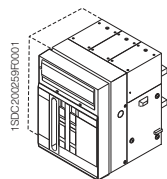

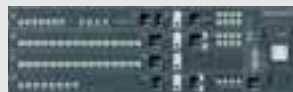
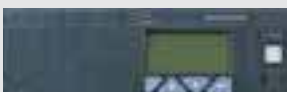
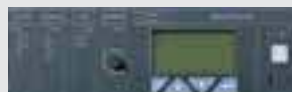
		
PR121/P	PR122/P	PR123/P
1SDA.....R1 3 Poles	1SDA.....R1 3 Poles	1SDA.....R1 3 Poles
4 Poles	4 Poles	4 Poles

E2N 16

Withdrawable (W) - MP

Icu (415 V) = **65 kA** Icw (1 s) = **55 kA**

MP = Moving part						
LI	055904	055912	055907	055915		
LSI	055905	055913	055908	055916	055910	055918
LSIG	055906	055914	055909	055917	055911	055919

E2S 16

Withdrawable (W) - MP

Icu (415 V) = **85 kA** Icw (1 s) = **65 kA**

MP = Moving part						
LI	056000	056008	056003	056011		
LSI	056001	056009	056004	056012	056006	056014
LSIG	056002	056010	056005	056013	056007	056015

E2L 16

Withdrawable (W) - MP

Icu (415 V) = **130 kA** Icw (1 s) = **10 kA**

MP = Moving part						
LI	056096	056104	056099	056107		
LSI	056097	056105	056100	056108	056102	056110
LSIG	056098	056106	056101	056109	056103	056111

E2B 20

Withdrawable (W) - MP

Icu (415 V) = **42 kA** Icw (1 s) = **42 kA**

MP = Moving part						
LI	055840	055848	055843	055851		
LSI	055841	055849	055844	055852	055846	055854
LSIG	055842	055850	055845	055853	055847	055855
LSIRc*			058613	058615		

* to be ordered with toroid for residual current protection (see code on page 9/58)

E2N 20

Withdrawable (W) - MP

Icu (415 V) = **65 kA** Icw (1 s) = **55 kA**

MP = Moving part						
LI	055936	055944	055939	055947		
LSI	055937	055945	055940	055948	055942	055950
LSIG	055938	055946	055941	055949	055943	055951
LSIRc*			058653	058655		

* to be ordered with toroid for residual current protection (see code on page 9/58)

E2S 20

Withdrawable (W) - MP

Icu (415 V) = **85 kA** Icw (1 s) = **65 kA**

MP = Moving part						
LI	056032	056040	056035	056043		
LSI	056033	056041	056036	056044	056038	056046
LSIG	056034	056042	056037	056045	056039	056047
LSIRc*			058685	058687		

* to be ordered with toroid for residual current protection (see code on page 9/58)

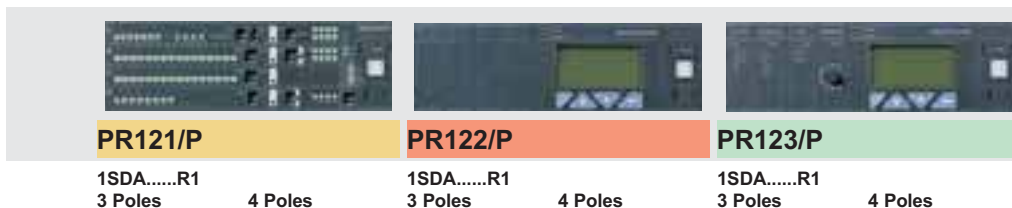
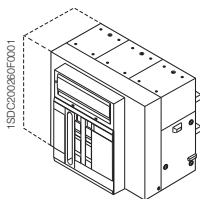

E3H 08

Fixed (F)

Icu (415 V) = 100 kA Icw (1 s) = 75 kA

HR = Horizontal rear terminals

LI	056336	056344	056339	056347		
LSI	056337	056345	056340	056348	056342	056350
LSIG	056338	056346	056341	056349	056343	056351
LSIRc*			058689			

* to be ordered with toroid for residual current protection (see code on page 9/58)

E3V 08

Fixed (F)

Icu (415 V) = 130 kA Icw (1 s) = 85 kA

HR = Horizontal rear terminals

LI	056528	056536	056531	056539		
LSI	056529	056537	056532	056540	056534	056542
LSIG	056530	056538	056533	056541	056535	056543
LSIRc*			058809			

* to be ordered with toroid for residual current protection (see code on page 9/58)

E3S 10

Fixed (F)

Icu (415 V) = 75 kA Icw (1 s) = 75 kA

HR = Horizontal rear terminals

LI	059385	059387	059397	059399		
LSI	059389	059391	059401	059403	059413	059415
LSIG	059393	059395	059405	059407	059417	059419

E3H 10

Fixed (F)

Icu (415 V) = 100 kA Icw (1 s) = 75 kA

HR = Horizontal rear terminals

LI	059345	059347	059357	059359		
LSI	059349	059351	059361	059363	059373	059375
LSIG	059353	059355	059365	059367	059377	059379

E3S 12

Fixed (F)

Icu (415 V) = 75 kA Icw (1 s) = 75 kA

HR = Horizontal rear terminals

LI	056176	056184	056179	056187		
LSI	056177	056185	056180	056188	056182	056190
LSIG	056178	056186	056181	056189	056183	056191
LSIRc*			058769			

* to be ordered with toroid for residual current protection (see code on page 9/58)

E3H 12

Fixed (F)

Icu (415 V) = 100 kA Icw (1 s) = 75 kA

HR = Horizontal rear terminals

LI	056368	056376	056371	056379		
LSI	056369	056377	056372	056380	056374	056382
LSIG	056370	056378	056373	056381	056375	056383
LSIRc*			058697			

* to be ordered with toroid for residual current protection (see code on page 9/58)

E3V 12

Fixed (F)

Icu (415 V) = 130 kA Icw (1 s) = 85 kA

HR = Horizontal rear terminals

LI	056560	056568	056563	056571		
LSI	056561	056569	056564	056572	056566	056574
LSIG	056562	056570	056565	056573	056567	056575
LSIRc*			058817			

* to be ordered with toroid for residual current protection (see code on page 9/58)

Fixed parts page 9/51 Terminals page 9/53 Extra codes page 9/54



Ordering codes

SACE Emax automatic circuit-breakers

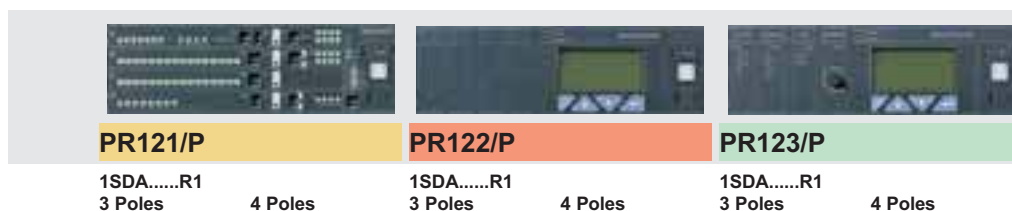
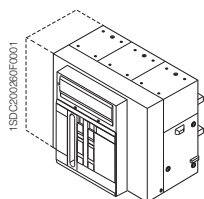

Icu (415 V) = 75 kA Icw (1 s) = 75 kA

HR = Horizontal rear terminals

LI	056208	056216	056211	056219		
LSI	056209	056217	056212	056220	056214	056222
LSIG	056210	056218	056213	056221	056215	056223

E3S 16

Fixed (F)

E3H 16

Fixed (F)

Icu (415 V) = 100 kA Icw (1 s) = 75 kA

HR = Horizontal rear terminals

LI	056400	056408	056403	056411		
LSI	056401	056409	056404	056412	056406	056414
LSIG	056402	056410	056405	056413	056407	056415

E3V 16

Fixed (F)

Icu (415 V) = 130 kA Icw (1 s) = 85 kA

HR = Horizontal rear terminals

LI	056592	056600	056595	056603		
LSI	056593	056601	056596	056604	056598	056606
LSIG	056594	056602	056597	056605	056599	056607

E3S 20

Fixed (F)

Icu (415 V) = 75 kA Icw (1 s) = 75 kA

HR = Horizontal rear terminals

LI	056240	056248	056243	056251		
LSI	056241	056249	056244	056252	056246	056254
LSIG	056242	056250	056245	056253	056247	056255
LSIRc*			058785			

* to be ordered with toroid for residual current protection (see code on page 9/58)

E3H 20

Fixed (F)

Icu (415 V) = 100 kA Icw (1 s) = 75 kA

HR = Horizontal rear terminals

LI	056432	056440	056435	056443		
LSI	056433	056441	056436	056444	056438	056446
LSIG	056434	056442	056437	056445	056439	056447
LSIRc*			058713			

* to be ordered with toroid for residual current protection (see code on page 9/58)

E3V 20

Fixed (F)

Icu (415 V) = 130 kA Icw (1 s) = 85 kA

HR = Horizontal rear terminals

LI	056624	056632	056627	056635		
LSI	056625	056633	056628	056636	056630	056638
LSIG	056626	056634	056629	056637	056631	056639
LSIRc*			058833			

* to be ordered with toroid for residual current protection (see code on page 9/58)

E3L 20

Fixed (F)

Icu (415 V) = 130 kA Icw (1 s) = 15 kA

HR = Horizontal rear terminals

LI	056720	056728	056723	056731		
LSI	056721	056729	056724	056732	056726	056734
LSIG	056722	056730	056725	056733	056727	056735
LSIRc*			058737			

* to be ordered with toroid for residual current protection (see code on page 9/58)

Fixed parts page 9/51 Terminals page 9/53 Extra codes page 9/54

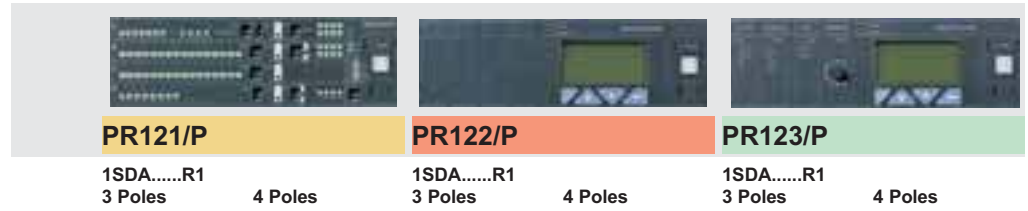
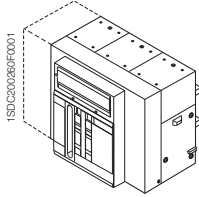

E3N 25

Fixed (F)

Icu (415 V) = 65 kA Icw (1 s) = 65 kA

HR = Horizontal rear terminals

LI	056112	056120	056115	056123		
LSI	056113	056121	056116	056124	056118	056126
LSIG	056114	056122	056117	056125	056119	056127

E3S 25

Fixed (F)

Icu (415 V) = 75 kA Icw (1 s) = 75 kA

HR = Horizontal rear terminals

LI	056272	056280	056275	056283		
LSI	056273	056281	056276	056284	056278	056286
LSIG	056274	056282	056277	056285	056279	056287

E3H 25

Fixed (F)

Icu (415 V) = 100 kA Icw (1 s) = 75 kA

HR = Horizontal rear terminals

LI	056464	056472	056467	056475		
LSI	056465	056473	056468	056476	056470	056478
LSIG	056466	056474	056469	056477	056471	056479

E3V 25

Fixed (F)

Icu (415 V) = 130 kA Icw (1 s) = 85 kA

HR = Horizontal rear terminals

LI	056656	056664	056659	056667		
LSI	056657	056665	056660	056668	056662	056670
LSIG	056658	056666	056661	056669	056663	056671

E3L 25

Fixed (F)

Icu (415 V) = 130 kA Icw (1 s) = 15 kA

HR = Horizontal rear terminals

LI	056752	056760	056755	056763		
LSI	056753	056761	056756	056764	056758	056766
LSIG	056754	056762	056757	056765	056759	056767

E3N 32

Fixed (F)

Icu (415 V) = 65 kA Icw (1 s) = 65 kA

HR = Horizontal rear terminals

LI	056144	056152	056147	056155		
LSI	056145	056153	056148	056156	056150	056158
LSIG	056146	056154	056149	056157	056151	056159
LSIRc*			058761			

* to be ordered with toroid for residual current protection (see code on page 9/58)

E3S 32

Fixed (F)

Icu (415 V) = 75 kA Icw (1 s) = 75 kA

HR = Horizontal rear terminals

LI	056304	056312	056307	056315		
LSI	056305	056313	056308	056316	056310	056318
LSIG	056306	056314	056309	056317	056311	056319
LSIRc*			058801			



* to be ordered with toroid for residual current protection (see code on page 9/58)

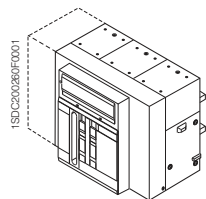

Ordering codes

SACE Emax automatic circuit-breakers



		
PR121/P	PR122/P	PR123/P
1SDA.....R1 3 Poles 4 Poles	1SDA.....R1 3 Poles 4 Poles	1SDA.....R1 3 Poles 4 Poles

E3H 32

Fixed (F)

Icu (415 V) = 100 kA Icw (1 s) = 75 kA

HR = Horizontal rear terminals

LI	056496	056504	056499	056507		
LSI	056497	056505	056500	056508	056502	056510
LSIG	056498	056506	056501	056509	056503	056511
LSIRc*			058729			

* to be ordered with toroid for residual current protection (see code on page 9/58)

E3V 32

Fixed (F)

Icu (415 V) = 130 kA Icw (1 s) = 85 kA

HR = Horizontal rear terminals

LI	056688	056696	056691	056699		
LSI	056689	056697	056692	056700	056694	056702
LSIG	056690	056698	056693	056701	056695	056703
LSIRc*			058849			

* to be ordered with toroid for residual current protection (see code on page 9/58)

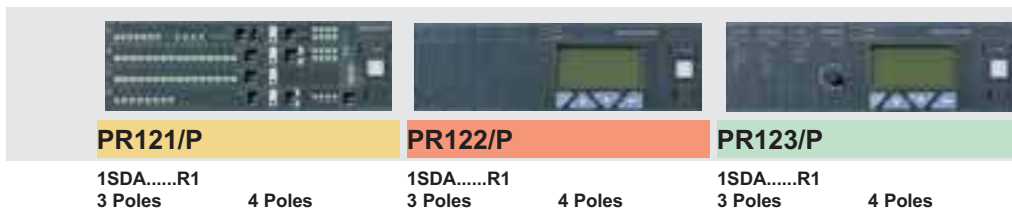
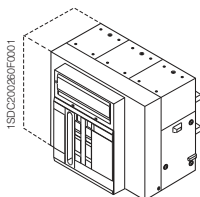

Icu (415 V) = 100 kA Icw (1 s) = 75 kA

E3H 08

Withdrawable (W) - MP

MP = Moving part

LI	056352	056360	056355	056363		
LSI	056353	056361	056356	056364	056358	056366
LSIG	056354	056362	056357	056365	056359	056367
LSIRc*	058693					

* to be ordered with toroid for residual current protection (see code on page 9/58)

E3V 08

Withdrawable (W) - MP

Icu (415 V) = 75 kA Icw (1 s) = 75 kA

MP = Moving part

LI	056544	056552	056547	056555		
LSI	056545	056553	056548	056556	056550	056558
LSIG	056546	056554	056549	056557	056551	056559
LSIRc*	058813					

* to be ordered with toroid for residual current protection (see code on page 9/58)

E3S 10

Withdrawable (W) - MP

Icu (415 V) = 75 kA Icw (1 s) = 75 kA

MP = Moving part

LI	059386	059388	059398	059400		
LSI	059390	059392	059402	059404	059414	059416
LSIG	059394	059396	059406	059408	059418	059420

E3H 10

Withdrawable (W) - MP

Icu (415 V) = 100 kA Icw (1 s) = 85 kA

MP = Moving part

LI	059346	059348	059358	059360		
LSI	059350	059352	059362	059364	059374	059376
LSIG	059354	059356	059366	059368	059378	059380

E3S 12

Withdrawable (W) - MP

Icu (415 V) = 75 kA Icw (1 s) = 75 kA

MP = Moving part

LI	056192	056200	056195	056203		
LSI	056193	056201	056196	056204	056198	056206
LSIG	056194	056202	056197	056205	056199	056207
LSIRc*	058773					

* to be ordered with toroid for residual current protection (see code on page 9/58)

E3H 12

Withdrawable (W) - MP

Icu (415 V) = 100 kA Icw (1 s) = 75 kA

MP = Moving part

LI	056384	056392	056387	056395		
LSI	056385	056393	056388	056396	056390	056398
LSIG	056386	056394	056389	056397	056391	056399
LSIRc*	058701					

* to be ordered with toroid for residual current protection (see code on page 9/58)

E3V 12

Withdrawable (W) - MP

Icu (415 V) = 130 kA Icw (1 s) = 85 kA

MP = Moving part

LI	056576	056584	056579	056587		
LSI	056577	056585	056580	056588	056582	056590
LSIG	056578	056586	056581	056589	056583	056591
LSIRc*	058821					

* to be ordered with toroid for residual current protection (see code on page 9/58)

Fixed parts page 9/51 Terminals page 9/53 Extra codes page 9/54



Ordering codes

SACE Emax automatic circuit-breakers

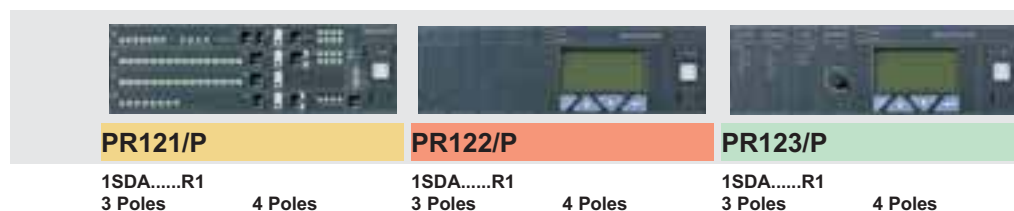
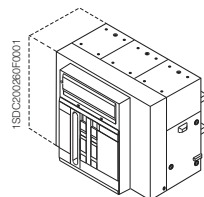

Icu (415 V) = **75 kA** Icw (1 s) = **75 kA**

MP = Moving part						
LI	056224	056232	056227	056235		
LSI	056225	056233	056228	056236	056230	056238
LSIG	056226	056234	056229	056237	056231	056239

E3S 16

Withdrawable (W) - MP

E3H 16

Withdrawable (W) - MP

Icu (415 V) = **100 kA** Icw (1 s) = **75 kA**

MP = Moving part						
LI	056416	056424	056419	056427		
LSI	056417	056425	056420	056428	056422	056430
LSIG	056418	056426	056421	056429	056423	056431

E3V 16

Withdrawable (W) - MP

Icu (415 V) = **130 kA** Icw (1 s) = **85 kA**

MP = Moving part						
LI	056608	056616	056611	056619		
LSI	056609	056617	056612	056620	056614	056622
LSIG	056610	056618	056613	056621	056615	056623

E3S 20

Withdrawable (W) - MP

Icu (415 V) = **75 kA** Icw (1 s) = **75 kA**

MP = Moving part						
LI	056256	056264	056259	056267		
LSI	056257	056265	056260	056268	056262	056270
LSIG	056258	056266	056261	056269	056263	056271
LSIRc*			058789			

* to be ordered with toroid for residual current protection (see code on page 9/58)

E3H 20

Withdrawable (W) - MP

Icu (415 V) = **100 kA** Icw (1 s) = **75 kA**

MP = Moving part						
LI	056448	056456	056451	056459		
LSI	056449	056457	056452	056460	056454	056462
LSIG	056450	056458	056453	056461	056455	056463
LSIRc*			058717			

* to be ordered with toroid for residual current protection (see code on page 9/58)

E3V 20

Withdrawable (W) - MP

Icu (415 V) = **130 kA** Icw (1 s) = **85 kA**

MP = Moving part						
LI	056640	056648	056643	056651		
LSI	056641	056649	056644	056652	056646	056654
LSIG	056642	056650	056645	056653	056647	056655
LSIRc*			058837			

* to be ordered with toroid for residual current protection (see code on page 9/58)

E3L 20

Withdrawable (W) - MP

Icu (415 V) = **130 kA** Icw (1 s) = **15 kA**

MP = Moving part						
LI	056736	056744	056739	056747		
LSI	056737	056745	056740	056748	056742	056750
LSIG	056738	056746	056741	056749	056743	056751
LSIRc*			058741			

* to be ordered with toroid for residual current protection (see code on page 9/58)

Fixed parts page 9/51 Terminals page 9/53 Extra codes page 9/54

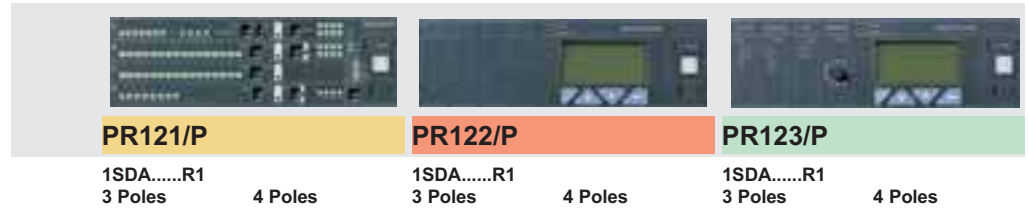
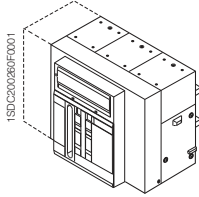

E3N 25

Withdrawable (W) - MP

Icu (415 V) = 65 kA Icw (1 s) = 65 kA

MP = Moving part						
LI	056128	056136	056131	056139		
LSI	056129	056137	056132	056140	056134	056142
LSIG	056130	056138	056133	056141	056135	056143

E3S 25

Withdrawable (W) - MP

Icu (415 V) = 75 kA Icw (1 s) = 75 kA

MP = Moving part						
LI	056288	056296	056291	056299		
LSI	056289	056297	056292	056300	056294	056302
LSIG	056290	056298	056293	056301	056295	056303

E3H 25

Withdrawable (W) - MP

Icu (415 V) = 100 kA Icw (1 s) = 75 kA

MP = Moving part						
LI	056480	056488	056483	056491		
LSI	056481	056489	056484	056492	056486	056494
LSIG	056482	056490	056485	056493	056487	056495

E3V 25

Withdrawable (W) - MP

Icu (415 V) = 130 kA Icw (1 s) = 85 kA

MP = Moving part						
LI	056672	056680	056675	056683		
LSI	056673	056681	056676	056684	056678	056686
LSIG	056674	056682	056677	056685	056679	056687

E3L 25

Withdrawable (W) - MP

Icu (415 V) = 130 kA Icw (1 s) = 15 kA

MP = Moving part						
LI	056768	056776	056771	056779		
LSI	056769	056777	056772	056780	056774	056782
LSIG	056770	056778	056773	056781	056775	056783

E3N 32

Withdrawable (W) - MP

Icu (415 V) = 65 kA Icw (1 s) = 65 kA

MP = Moving part						
LI	056160	056168	056163	056171		
LSI	056161	056169	056164	056172	056166	056174
LSIG	056162	056170	056165	056173	056167	056175
LSIRc*			058765			

* to be ordered with toroid for residual current protection (see code on page 9/58)

E3S 32

Withdrawable (W) - MP

Icu (415 V) = 75 kA Icw (1 s) = 75 kA

MP = Moving part						
LI	056320	056328	056323	056331		
LSI	056321	056329	056324	056332	056326	056334
LSIG	056322	056330	056325	056333	056327	056335
LSIRc*			058805			

* to be ordered with toroid for residual current protection (see code on page 9/58)



Ordering codes

SACE Emax automatic circuit-breakers

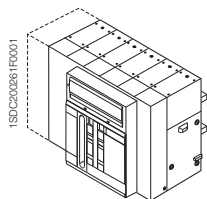

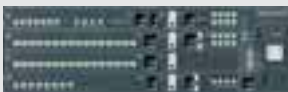
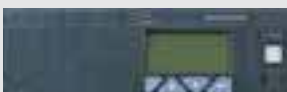
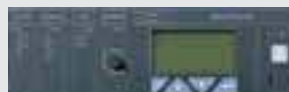
		
PR121/P	PR122/P	PR123/P
1SDA.....R1 3 Poles	1SDA.....R1 3 Poles	1SDA.....R1 3 Poles
4 Poles	4 Poles	4 Poles

E3H 32

Withdrawable (W) - MP

Icu (415 V) = 100 kA Icw (1 s) = 75 kA

MP = Moving part						
LI	056512	056520	056515	056523		
LSI	056513	056521	056516	056524	056518	056526
LSIG	056514	056522	056517	056525	056519	056527
LSIRc*	058733					

* to be ordered with toroid for residual current protection (see code on page 9/58)

E3V 32

Withdrawable (W) - MP

Icu (415 V) = 130 kA Icw (1 s) = 85 kA

MP = Moving part						
LI	056704	056712	056707	056715		
LSI	056705	056713	056708	056716	056710	056718
LSIG	056706	056714	056709	056717	056711	056719
LSIRc*	058853					

* to be ordered with toroid for residual current protection (see code on page 9/58)

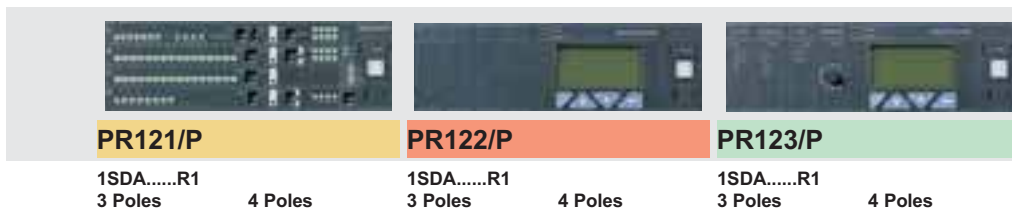
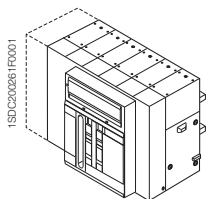

E4H 32

Fixed (F)

Icu (415 V) = 100 kA Icw (1 s) = 100 kA

HR = Horizontal rear terminals

LI	056816	056824	056819	056827		
LSI	056817	056825	056820	056828	056822	056830
LSIG	056818	056826	056821	056829	056823	056831

E4V 32

Fixed (F)

Icu (415 V) = 150 kA Icw (1 s) = 100 kA

HR = Horizontal rear terminals

LI	056880	056888	056883	056891		
LSI	056881	056889	056884	056892	056886	056894
LSIG	056882	056890	056885	056893	056887	056895

E4S 40

Fixed (F)

Icu (415 V) = 75 kA Icw (1 s) = 75 kA

HR = Horizontal rear terminals

LI	056784	056792	056787	056795		
LSI	056785	056793	056788	056796	056790	056798
LSIG	056786	056794	056789	056797	056791	056799

E4H 40

Fixed (F)

Icu (415 V) = 100 kA Icw (1 s) = 100 kA

HR = Horizontal rear terminals

LI	056848	056856	056851	056859		
LSI	056849	056857	056852	056860	056854	056862
LSIG	056850	056858	056853	056861	056855	056863

E4V 40

Fixed (F)

Icu (415 V) = 150 kA Icw (1 s) = 100 kA

HR = Horizontal rear terminals



LI	056912	056920	056915	056923		
LSI	056913	056921	056916	056924	056918	056926
LSIG	056914	056922	056917	056925	056919	056927

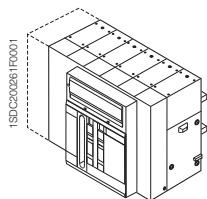

Ordering codes

SACE Emax automatic circuit-breakers



		
PR121/P	PR122/P	PR123/P
1SDA.....R1 3 Poles	1SDA.....R1 3 Poles	1SDA.....R1 3 Poles
4 Poles	4 Poles	4 Poles

E4H 32

Withdrawable (W) - MP

Icu (415 V) = 100 kA Icw (1 s) = 100 kA

MP = Moving part						
LI	056832	056840	056835	056843		
LSI	056833	056841	056836	056844	056838	056846
LSIG	056834	056842	056837	056845	056839	056847

E4V 32

Withdrawable (W) - MP

Icu (415 V) = 150 kA Icw (1 s) = 100 kA

MP = Moving part						
LI	056896	056904	056899	056907		
LSI	056897	056905	056900	056908	056902	056910
LSIG	056898	056906	056901	056909	056903	056911

E4S 40

Withdrawable (W) - MP

Icu (415 V) = 75 kA Icw (1 s) = 75 kA

MP = Moving part						
LI	056800	056808	056803	056811		
LSI	056801	056809	056804	056812	056806	056814
LSIG	056802	056810	056805	056813	056807	056815

E4H 40

Withdrawable (W) - MP

Icu (415 V) = 100 kA Icw (1 s) = 100 kA

MP = Moving part						
LI	056864	056872	056867	056875		
LSI	056865	056873	056868	056876	056870	056878
LSIG	056866	056874	056869	056877	056871	056879

E4V 40

Withdrawable (W) - MP

Icu (415 V) = 150 kA Icw (1 s) = 100 kA

MP = Moving part						
LI	056928	056936	056931	056939		
LSI	056929	056937	056932	056940	056934	056942
LSIG	056930	056938	056933	056941	056935	056943

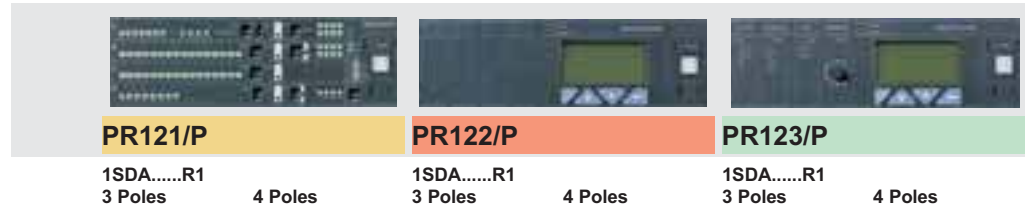
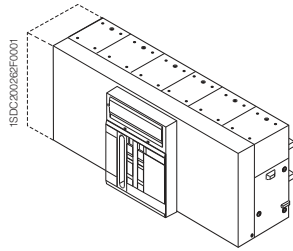

E6V 32

Fixed (F)

Icu (415 V) = 150 kA Icw (1 s) = 100 kA

HR = Horizontal rear terminals

LI	057040	057048	057043	057051		
LSI	057041	057049	057044	057052	057046	057054
LSIG	057042	057050	057045	057053	057047	057055

E6H 40

Fixed (F)

Icu (415 V) = 100 kA Icw (1 s) = 100 kA

HR = Horizontal rear terminals

LI	056944	056952	056947	056955		
LSI	056945	056953	056948	056956	056950	056958
LSIG	056946	056954	056949	056957	056951	056959

E6V 40

Fixed (F)

Icu (415 V) = 150 kA Icw (1 s) = 100 kA

HR = Horizontal rear terminals

LI	057072	057080	057075	057083		
LSI	057073	057081	057076	057084	057078	057086
LSIG	057074	057082	057077	057085	057079	057087

E6H 50

Fixed (F)

Icu (415 V) = 100 kA Icw (1 s) = 100 kA

HR = Horizontal rear terminals

LI	056976	056984	056979	056987		
LSI	056977	056985	056980	056988	056982	056990
LSIG	056978	056986	056981	056989	056983	056991

E6V 50

Fixed (F)

Icu (415 V) = 150 kA Icw (1 s) = 100 kA

HR = Horizontal rear terminals

LI	057104	057112	057107	057115		
LSI	057105	057113	057108	057116	057110	057118
LSIG	057106	057114	057109	057117	057111	057119

E6H 63

Fixed (F)

Icu (415 V) = 100 kA Icw (1 s) = 100 kA

HR = Horizontal rear terminals

LI	057008	057016	057011	057019		
LSI	057009	057017	057012	057020	057014	057022
LSIG	057010	057018	057013	057021	057015	057023

E6V 63

Fixed (F)

Icu (415 V) = 150 kA Icw (1 s) = 100 kA

HR = Horizontal rear terminals

LI	057136	057144	057139	057147		
LSI	057137	057145	057140	057148	057142	057150
LSIG	057138	057146	057141	057149	057143	057151



Ordering codes

SACE Emax automatic circuit-breakers

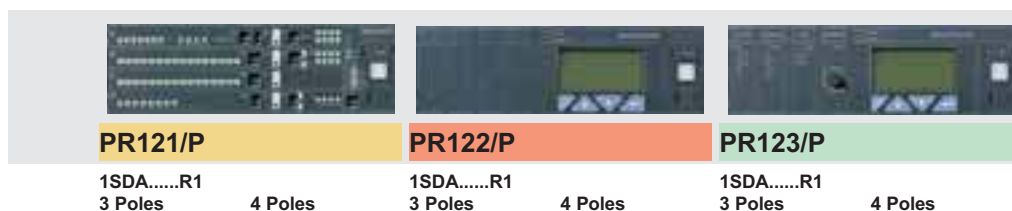
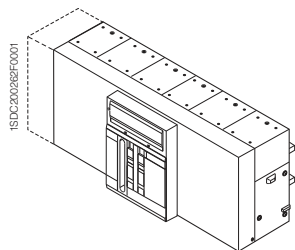

PR121/P

1SDA.....R1
3 Poles 4 Poles

PR122/P

1SDA.....R1
3 Poles 4 Poles

PR123/P

1SDA.....R1
3 Poles 4 Poles

E6V 32

Withdrawable (W) - MP

Icu (415 V) = 150 kA Icw (1 s) = 100 kA

MP = Moving part						
LI	057056	057064	057059	057067		
LSI	057057	057065	057060	057068	057062	057070
LSIG	057058	057066	057061	057069	057063	057071

E6H 40

Withdrawable (W) - MP

Icu (415 V) = 100 kA Icw (1 s) = 100 kA

MP = Moving part						
LI	056960	056968	056963	056971		
LSI	056961	056969	056964	056972	056966	056974
LSIG	056962	056970	056965	056973	056967	056975

E6V 40

Withdrawable (W) - MP

Icu (415 V) = 150 kA Icw (1 s) = 100 kA

MP = Moving part						
LI	057088	057096	057091	057099		
LSI	057089	057097	057092	057100	057094	057102
LSIG	057090	057098	057093	057101	057095	057103

E6H 50

Withdrawable (W) - MP

Icu (415 V) = 100 kA Icw (1 s) = 100 kA

MP = Moving part						
LI	056992	057000	056995	057003		
LSI	056993	057001	056996	057004	056998	057006
LSIG	056994	057002	056997	057005	056999	057007

E6V 50

Withdrawable (W) - MP

Icu (415 V) = 150 kA Icw (1 s) = 100 kA

MP = Moving part						
LI	057120	057128	057123	057131		
LSI	057121	057129	057124	057132	057126	057134
LSIG	057122	057130	057125	057133	057127	057135

E6H 63

Withdrawable (W) - MP

Icu (415 V) = 100 kA Icw (1 s) = 100 kA

MP = Moving part						
LI	057024	057032	057027	057035		
LSI	057025	057033	057028	057036	057030	057038
LSIG	057026	057034	057029	057037	057031	057039

E6V 63

Withdrawable (W) - MP

Icu (415 V) = 150 kA Icw (1 s) = 100 kA

MP = Moving part						
LI	057152	057160	057155	057163		
LSI	057153	057161	057156	057164	057158	057166
LSIG	057154	057162	057157	057165	057159	057167

Ordering codes

SACE Emax automatic circuit-breakers with full-size neutral conductor

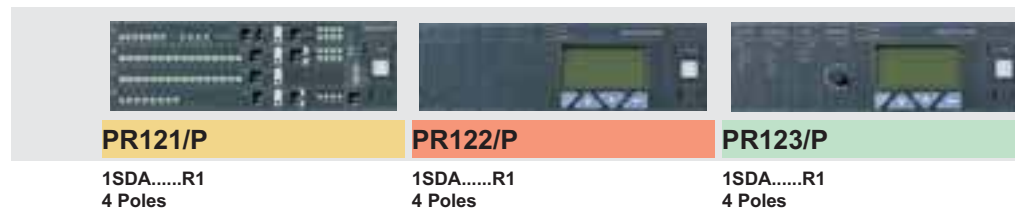
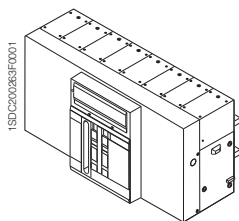

E4H/f 32

Fixed (F)

I_{cu} (415 V) = 100 kA I_{cw} (1 s) = 85 kA

HR = Horizontal rear terminals

LI	059429	059432	
LSI	059430	059433	059435
LSIG	059431	059434	059436

E4S/f 40

Fixed (F)

I_{cu} (415 V) = 80 kA I_{cw} (1 s) = 80 kA

HR = Horizontal rear terminals

LI	055536	055539	
LSI	055537	055540	055542
LSIG	055538	055541	055543

E4H/f 40

Fixed (F)

I_{cu} (415 V) = 100 kA I_{cw} (1 s) = 85 kA

HR = Horizontal rear terminals

LI	055520	055523	
LSI	055521	055524	055526
LSIG	055522	055525	055527

E4H/f 32

Withdrawable (W) - MP

I_{cu} (415 V) = 100 kA I_{cw} (1 s) = 85 kA

MP = Moving part

LI	059437	059440	
LSI	059438	059441	059443
LSIG	059439	059442	059444

E4S/f 40

Withdrawable (W) - MP

I_{cu} (415 V) = 80 kA I_{cw} (1 s) = 80 kA

MP = Moving part

LI	055544	055547	
LSI	055545	055548	055550
LSIG	055546	055549	055551

E4H/f 40

Withdrawable (W) - MP

I_{cu} (415 V) = 100 kA I_{cw} (1 s) = 80 kA

MP = Moving part

LI	055528	055531	
LSI	055529	055532	055534
LSIG	055530	055533	055535



Ordering codes

SACE Emax automatic circuit-breakers with full-size neutral conductor

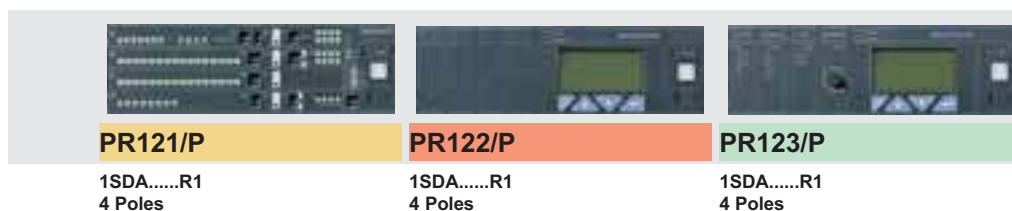
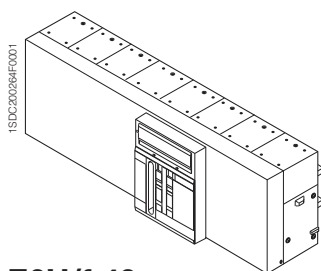

E6H/f 40

Fixed (F)

Icu (415 V) = **100 kA** Icw (1 s) = **100 kA**

HR = Horizontal rear terminals

LI	055552	055555	
LSI	055553	055556	055558
LSIG	055554	055557	055559

E6H/f 50

Fixed (F)

Icu (415 V) = **100 kA** Icw (1 s) = **100 kA**

HR = Horizontal rear terminals

LI	055568	055571	
LSI	055569	055572	055574
LSIG	055570	055573	055575

E6H/f 63

Fixed (F)

Icu (415 V) = **100 kA** Icw (1 s) = **100 kA**

HR = Horizontal rear terminals

LI	055584	055587	
LSI	055585	055588	055590
LSIG	055586	055589	055591

E6H/f 40

Withdrawable (W) - MP

Icu (415 V) = **100 kA** Icw (1 s) = **100 kA**

MP = Moving part

LI	055560	055563	
LSI	055561	055564	055566
LSIG	055562	055565	055567

E6H/f 50

Withdrawable (W) - MP

Icu (415 V) = **100 kA** Icw (1 s) = **100 kA**

MP = Moving part

LI	055576	055579	
LSI	055577	055580	055582
LSIG	055578	055581	055583

E6H/f 63

Withdrawable (W) - MP

Icu (415 V) = **100 kA** Icw (1 s) = **100 kA**

MP = Moving part

LI	055592	055595	
LSI	055593	055596	055598
LSIG	055594	055597	055599

Ordering codes

SACE Emax switch-disconnectors

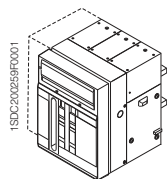

1SDA.....R1
3 Poles 4 Poles

E1B/MS 08

Fixed (F)

I_{cw} (1s) = 42 kA

HR = Horizontal rear terminals

058931 058932

E1N/MS 08

Fixed (F)

I_{cw} (1s) = 50 kA

HR = Horizontal rear terminals

058933 058934

E1B/MS 10

Fixed (F)

I_{cw} (1s) = 42 kA

HR = Horizontal rear terminals

059209 059211

E1N/MS 10

Fixed (F)

I_{cw} (1s) = 50 kA

HR = Horizontal rear terminals

059253 059255

E1B/MS 12

Fixed (F)

I_{cw} (1s) = 42 kA

HR = Horizontal rear terminals

058935 058936

E1N/MS 12

Fixed (F)

I_{cw} (1s) = 50 kA

HR = Horizontal rear terminals

058937 058938

E1B/MS 16

Fixed (F)

I_{cw} (1s) = 42 kA

HR = Horizontal rear terminals

058857 058858

E1N/MS 16

Fixed (F)

I_{cw} (1s) = 50 kA

HR = Horizontal rear terminals

058861 058862



Ordering codes

SACE Emax switch-disconnectors

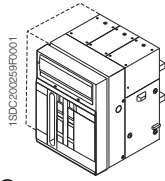

1SDA.....R1
3 Poles 4 Poles

E1B/MS 08

Withdrawable (W) - MP

Icw (1s) = 42 kA

MP = Moving part

	058939	058940
--	--------	--------

E1N/MS 08

Withdrawable (W) - MP

Icw (1s) = 50 kA

MP = Moving part

	058941	058942
--	--------	--------

E1B/MS 10

Withdrawable (W) - MP

Icw (1s) = 42 kA

MP = Moving part

	059210	059212
--	--------	--------

E1N/MS 10

Withdrawable (W) - MP

Icw (1s) = 50 kA

MP = Moving part

	059254	059256
--	--------	--------

E1B/MS 12

Withdrawable(W) - MP

Icw (1s) = 42 kA

MP = Moving part

	058943	058944
--	--------	--------

E1N/MS 12

Withdrawable (W) - MP

Icw (1s) = 50 kA

MP = Moving part

	058945	058946
--	--------	--------

E1B/MS 16

Withdrawable(W) - MP

Icw (1s) = 42 kA

MP = Moving part

	058859	058860
--	--------	--------

E1N/MS 16

Withdrawable (W) - MP

Icw (1s) = 50 kA

MP = Moving part

	058863	058864
--	--------	--------

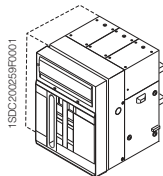

1SDA.....R1
3 Poles 4 Poles

E2N/MS 10

Fixed (F)

I_{cw} (1s) = 55 kA

HR = Horizontal rear terminals

059297 059299

E2S/MS 10

Fixed (F)

I_{cw} (1s) = 65 kA

HR = Horizontal rear terminals

059341 059343

E2N/MS 12

Fixed (F)

I_{cw} (1s) = 55 kA

HR = Horizontal rear terminals

058947 058948

E2S/MS 12

Fixed (F)

I_{cw} (1s) = 65 kA

HR = Horizontal rear terminals

058865 058866

E2B/MS 16

Fixed (F)

I_{cw} (1s) = 42 kA

HR = Horizontal rear terminals

058949 058950

E2N/MS 16

Fixed (F)

I_{cw} (1s) = 55 kA

HR = Horizontal rear terminals

058951 058952

E2S/MS 16

Fixed (F)

I_{cw} (1s) = 65 kA

HR = Horizontal rear terminals

058869 058870

E2B/MS 20

Fixed (F)

I_{cw} (1s) = 42 kA

HR = Horizontal rear terminals

058953 058954

E2N/MS 20

Fixed (F)

I_{cw} (1s) = 55 kA

HR = Horizontal rear terminals

058955 058956

E2S/MS 20

Fixed (F)

I_{cw} (1s) = 65 kA

HR = Horizontal rear terminals

058873 058874

Fixed parts page 9/51 Terminals page 9/53



Ordering codes

SACE Emax switch-disconnectors

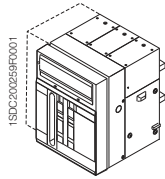

1SDA.....R1	4 Poles
3 Poles	

E2N/MS 10

Withdrawable (W) - MP

Icw (1s) = 55 kA

MP = Moving part

059298	059300
--------	--------

E2S/MS 10

Withdrawable (W) - MP

Icw (1s) = 65 kA

MP = Moving part

059342	059344
--------	--------

E2N/MS 12

Withdrawable (W) - MP

Icw (1s) = 55 kA

MP = Moving part

058957	058958
--------	--------

E2S/MS 12

Withdrawable (W) - MP

Icw (1s) = 65 kA

MP = Moving part

058867	058868
--------	--------

E2B/MS 16

Withdrawable (W) - MP

Icw (1s) = 42 kA

MP = Moving part

058959	058960
--------	--------

E2N/MS 16

Withdrawable (W) - MP

Icw (1s) = 55 kA

MP = Moving part

058961	058962
--------	--------

E2S/MS 16

Withdrawable (W) - MP

Icw (1s) = 65 kA

MP = Moving part

058871	058872
--------	--------

E2B/MS 20

Withdrawable (W) - MP

Icw (1s) = 42 kA

MP = Moving part

058963	058964
--------	--------

E2N/MS 20

Withdrawable (W) - MP

Icw (1s) = 55 kA

MP = Moving part

058965	058966
--------	--------

E2S/MS 20

Withdrawable (W) - MP

Icw (1s) = 65 kA

MP = Moving part

058875	058876
--------	--------

Fixed parts page 9/51	Terminals page 9/53
-----------------------------	---------------------------

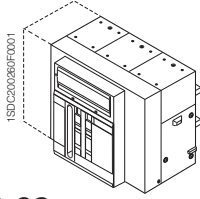

1SDA.....R1
3 Poles 4 Poles

E3V/MS 08

Fixed (F)

I_{cw} (1s) = **85 kA**

HR = Horizontal rear terminals

058877 058878

E3S/MS 10

Fixed (F)

I_{cw} (1s) = **75 kA**

HR = Horizontal rear terminals

059425 059427

E3S/MS 12

Fixed (F)

I_{cw} (1s) = **75 kA**

HR = Horizontal rear terminals

058967 058968

E3V/MS 12

Fixed (F)

I_{cw} (1s) = **85 kA**

HR = Horizontal rear terminals

058881 058882

E3S/MS 16

Fixed (F)

I_{cw} (1s) = **75 kA**

HR = Horizontal rear terminals

058969 058970

E3V/MS 16

Fixed (F)

I_{cw} (1s) = **85 kA**

HR = Horizontal rear terminals

058885 058886

E3S/MS 20

Fixed (F)

I_{cw} (1s) = **75 kA**

HR = Horizontal rear terminals

058971 058972

E3V/MS 20

Fixed (F)

I_{cw} (1s) = **85 kA**

HR = Horizontal rear terminals

058889 058890

E3N/MS 25

Fixed (F)

I_{cw} (1s) = **65 kA**

HR = Horizontal rear terminals

058973 058974

E3S/MS 25

Fixed (F)

I_{cw} (1s) = **75 kA**

HR = Horizontal rear terminals

058975 058976

Fixed parts page 9/51 Terminals page 9/53



Ordering codes

SACE Emax switch-disconnectors

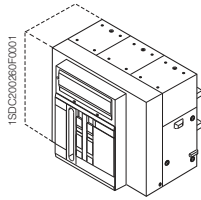

1SDA.....R1
3 Poles 4 Poles

E3V/MS 25

Fixed (F)

Icw (1s) = 85 kA

HR = Horizontal rear terminals

	058893	058894
--	--------	--------

E3N/MS 32

Fixed (F)

Icw (1s) = 65 kA

HR = Horizontal rear terminals

	058977	058978
--	--------	--------

E3S/MS 32

Fixed (F)

Icw (1s) = 75 kA

HR = Horizontal rear terminals

	058979	058980
--	--------	--------

E3V/MS 32

Fixed (F)

Icw (1s) = 85 kA

HR = Horizontal rear terminals

	058897	058898
--	--------	--------

E3V/MS 08

Withdrawable (W) - MP

Icw (1s) = 85 kA

MP = Moving part

	058879	058880
--	--------	--------

E3S/MS 10

Withdrawable (W) - MP

Icw (1s) = 75 kA

MP = Moving part

	059426	059428
--	--------	--------

E3S/MS 12

Withdrawable (W) - MP

Icw (1s) = 75 kA

MP = Moving part

	058981	058982
--	--------	--------

E3V/MS 12

Withdrawable (W) - MP

Icw (1s) = 85 kA

MP = Moving part

	058883	058884
--	--------	--------

E3S/MS 16

Withdrawable (W) - MP

Icw (1s) = 75 kA

MP = Moving part

	058983	058984
--	--------	--------

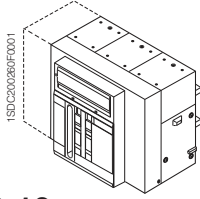

1SDA.....R1	
3 Poles	4 Poles

E3V/MS 16

I_{cw} (1s) = 85 kA

Withdrawable (W) - MP

MP = Moving part		
	058887	058888

E3S/MS 20

I_{cw} (1s) = 75 kA

Withdrawable (W) - MP

MP = Moving part		
	058985	058986

E3V/MS 20

I_{cw} (1s) = 85 kA

Withdrawable (W) - MP

MP = Moving part		
	058891	058892

E3N/MS 25

I_{cw} (1s) = 65 kA

Withdrawable (W) - MP

MP = Moving part		
	058987	058988

E3S/MS 25

I_{cw} (1s) = 75 kA

Withdrawable (W) - MP

MP = Moving part		
	058989	058990

E3V/MS 25

I_{cw} (1s) = 85 kA

Withdrawable (W) - MP

MP = Moving part		
	058895	058896

E3N/MS 32

I_{cw} (1s) = 65 kA

Withdrawable (W) - MP

MP = Moving part		
	058991	058992

E3S/MS 32

I_{cw} (1s) = 75 kA

Withdrawable (W) - MP

MP = Moving part		
	058993	058994

E3V/MS 32

I_{cw} (1s) = 85 kA

Withdrawable (W) - MP

MP = Moving part		
	058899	058900

Fixed parts page 9/51 Terminals page 9/53



Ordering codes

SACE Emax switch-disconnectors

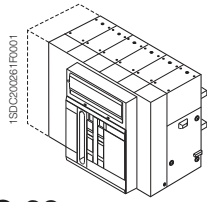

1SDA.....R1
3 Poles 4 Poles

E4H/MS 32 Fixed (F)

Icw (1s) = 100 kA

HR = Horizontal rear terminals

058995	058996
--------	--------

E4S/MS 40 Fixed (F)

Icw (1s) = 75 kA

HR = Horizontal rear terminals

058997	058998
--------	--------

E4H/MS 40 Fixed (F)

Icw (1s) = 100 kA

HR = Horizontal rear terminals

058999	059000
--------	--------

E4H/MS 32 Withdrawable (W) - MP

Icw (1s) = 100 kA

MP = Moving part

059001	059002
--------	--------

E4S/MS 40 Withdrawable (W) - MP

Icw (1s) = 75 kA

MP = Moving part

059003	059004
--------	--------

E4H/MS 40 Withdrawable (W) - MP

Icw (1s) = 100 kA

MP = Moving part

059005	059006
--------	--------

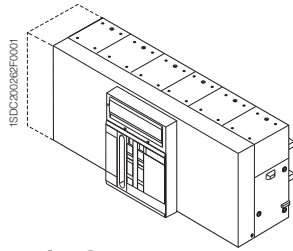

1SDA.....R1
3 Poles 4 Poles

E6H/MS 40
Fixed (F)

I_{cw} (1s) = 100 kA

HR = Horizontal rear terminals

058905	058906
--------	--------

E6H/MS 50
Fixed (F)

I_{cw} (1s) = 100 kA

HR = Horizontal rear terminals

059007	059008
--------	--------

E6H/MS 63
Fixed (F)

I_{cw} (1s) = 100 kA

HR = Horizontal rear terminals

059009	059010
--------	--------

E6H/MS 40
Withdrawable (W) - MP

I_{cw} (1s) = 100 kA

MP = Moving part

058907	058908
--------	--------

E6H/MS 50
Withdrawable (W) - MP

I_{cw} (1s) = 100 kA

MP = Moving part

059011	059012
--------	--------

E6H/MS 63
Withdrawable (W) - MP

I_{cw} (1s) = 100 kA

MP = Moving part

059013	059014
--------	--------



Ordering codes

SACE Emax switch-disconnectors with full size neutral conductor

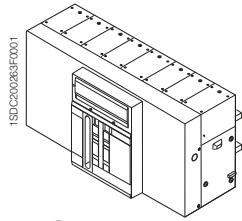

1SDA.....R1
4 Poles

E4H/f MS 32

Fixed (F)

Icw (1s) = **85 kA**

HR = Horizontal rear terminals

058901

E4S/f MS 40

Fixed (F)

Icw (1s) = **80 kA**

HR = Horizontal rear terminals

059015

E4H/f MS 40

Fixed (F)

Icw (1s) = **85 kA**

HR = Horizontal rear terminals

058903

E4H/f MS 32

Withdrawable (W) -
MP

Icw (1s) = **85 kA**

MP = Moving part

058902

E4S/f MS 40

Withdrawable (W) -
MP

Icw (1s) = **80 kA**

MP = Moving part

059016

E4H/f MS 40

Withdrawable (W) -
MP

Icw (1s) = **85 kA**

MP = Moving part

058904

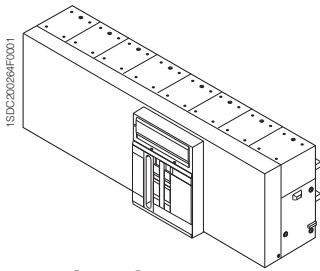

1SDA.....R1
4 Poles

E6H/f MS 40

Fixed (F)

I_{cw} (1s) = 100 kA

HR = Horizontal rear terminals

058909

E6H/f MS 50

Fixed (F)

I_{cw} (1s) = 100 kA

HR = Horizontal rear terminals

059017

E6H/f MS 63

Fixed (F)

I_{cw} (1s) = 100 kA

HR = Horizontal rear terminals

059018

E6H/f MS 40

**Withdrawable (W) -
MP**

I_{cw} (1s) = 100 kA

MP = Moving part

058910

E6H/f MS 50

**Withdrawable (W) -
MP**

I_{cw} (1s) = 100 kA

MP = Moving part

059019

E6H/f MS 63

**Withdrawable (W) -
MP**

I_{cw} (1s) = 100 kA

MP = Moving part

059020



Ordering codes

SACE Emax automatic circuit-breakers for applications up to 1150V AC

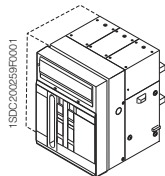

1SDA.....R1

E2B/E 16

Icu (1150 V AC) = **20 kA**

059633

Note: to be specified in addition to the code of the standard version E2B 16 circuit-breaker (Ue=690 V AC). Page 9/7 for fixed circuit-breaker, page 9/9 for withdrawable circuit-breaker.

E2B/E 20

Icu (1150 V AC) = **20 kA**

059634

Note: to be specified in addition to the code of the standard version E2B 20 circuit-breaker (Ue=690 V AC). Page 9/8 for fixed circuit-breaker, page 9/10 for withdrawable circuit-breaker.

E2N/E 12

Icu (1150 V AC) = **30 kA**

059635

Note: to be specified in addition to the code of the standard version E2N 12 circuit-breaker (Ue=690 V AC). Page 9/7 for fixed circuit-breaker, page 9/9 for withdrawable circuit-breaker.

E2N/E 16

Icu (1150 V AC) = **30 kA**

059636

Note: to be specified in addition to the code of the standard version E2N 16 circuit-breaker (Ue=690 V AC). Page 9/8 for fixed circuit-breaker, page 9/10 for withdrawable circuit-breaker.

E2N/E 20

Icu (1150 V AC) = **30 kA**

059637

Note: to be specified in addition to the code of the standard version E2N 20 circuit-breaker (Ue=690 V AC). Page 9/8 for fixed circuit-breaker, page 9/10 for withdrawable circuit-breaker.

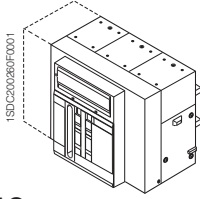

1SDA.....R1

E3H/E 12

Icu (1150 V AC) = 30 kA

059638

Note: to be specified in addition to the code of the standard version E3H 12 circuit-breaker (Ue=690 V AC). Page 9/11 for fixed circuit-breaker, page 9/15 for withdrawable circuit-breaker.

E3H/E 16

Icu (1150 V AC) = 30 kA

059639

Note: to be specified in addition to the code of the standard version E3H 16 circuit-breaker (Ue=690 V AC). Page 9/12 for fixed circuit-breaker, page 9/16 for withdrawable circuit-breaker.

E3H/E 20

Icu (1150 V AC) = 30 kA

059640

Note: to be specified in addition to the code of the standard version E3H 20 circuit-breaker (Ue=690 V AC). Page 9/12 for fixed circuit-breaker, page 9/16 for withdrawable circuit-breaker.

E3H/E 25

Icu (1150 V AC) = 30 kA

059641

Note: to be specified in addition to the code of the standard version E3H 25 circuit-breaker (Ue=690 V AC). Page 9/13 for fixed circuit-breaker, page 9/17 for withdrawable circuit-breaker.

E3H/E 32

Icu (1150 V AC) = 30 kA

059642

Note: to be specified in addition to the code of the standard version E3H 32 circuit-breaker (Ue=690 V AC). Page 9/14 for fixed circuit-breaker, page 9/18 for withdrawable circuit-breaker.



Ordering codes

SACE Emax automatic circuit-breakers for applications up to 1150V AC

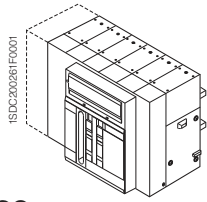

E4H/E 32

Icu (1150 V AC) = 65 kA

1SDA.....R1

059643

Note: to be specified in addition to the code of the standard version E4H 32 circuit-breaker (Ue=690 V AC). Page 9/19 for fixed circuit-breaker, page 9/20 for withdrawable circuit-breaker.

E4H/E 40

Icu (1150 V AC) = 65 kA

059644

Note: to be specified in addition to the code of the standard version E4H 40 circuit-breaker (Ue=690 V AC). Page 9/19 for fixed circuit-breaker, page 9/20 for withdrawable circuit-breaker.

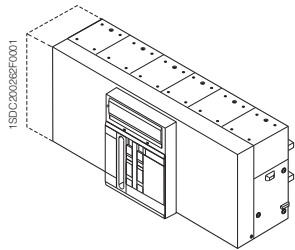

E6H/E 40

Icu (1150 V AC) = 65 kA

1SDA.....R1

058550

Note: to be specified in addition to the code of the standard version E6H 40 circuit-breaker (Ue=690 V AC). Page 9/21 for fixed circuit-breaker, page 9/22 for withdrawable circuit-breaker.

E6H/E 50

Icu (1150 V AC) = 65 kA

058551

Note: to be specified in addition to the code of the standard version E6H 50 circuit-breaker (Ue=690 V AC). Page 9/21 for fixed circuit-breaker, page 9/22 for withdrawable circuit-breaker.

E6H/E 63

Icu (1150 V AC) = 65 kA

058552

Note: to be specified in addition to the code of the standard version E6H 63 circuit-breaker (Ue=690 V AC). Page 9/21 for fixed circuit-breaker, page 9/22 for withdrawable circuit-breaker.

Ordering codes

SACE Emax switch-disconnectors
for applications up to 1150V AC

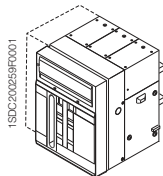

1SDA.....R1

E2B/E MS 16

I_{cw} (1 s) = 20 kA

059633

Note: to be specified with the code of the standard version circuit-breaker ($U_e = 690V$ AC). Page 9/27 for fixed MS, page 9/28 for withdrawable MS.

E2B/E MS 20

I_{cw} (1 s) = 20 kA

059634

Note: to be specified with the code of the standard version circuit-breaker ($U_e = 690V$ AC). Page 9/27 for fixed MS, page 9/28 for withdrawable MS.

E2N/E MS 12

I_{cw} (1 s) = 30 kA

059635

Note: to be specified with the code of the standard version circuit-breaker ($U_e = 690V$ AC). Page 9/27 for fixed MS, page 9/28 for withdrawable MS.

E2N/E MS 16

I_{cw} (1 s) = 30 kA

059636

Note: to be specified with the code of the standard version circuit-breaker ($U_e = 690V$ AC). Page 9/27 for fixed MS, page 9/28 for withdrawable MS.

E2N/E MS 20

I_{cw} (1 s) = 30 kA

059637

Note: to be specified with the code of the standard version circuit-breaker ($U_e = 690V$ AC). Page 9/27 for fixed MS, page 9/28 for withdrawable MS.



Ordering codes

SACE Emax switch-disconnectors
for applications up to 1150V AC

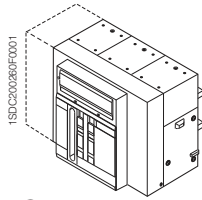

1SDA.....R1
3 Poles 4 Poles

E3H/E MS 12

Fixed (F)

Icw (1 s) = 30 kA

HR = Horizontal rear terminals

Circuit-breaker code	059021	059022
Additional code to be specified with the circuit-breaker	059638	059638

E3H/E MS 16

Fixed (F)

Icw (1 s) = 30 kA

HR = Horizontal rear terminals

Circuit-breaker code	059023	059024
Additional code to be specified with the circuit-breaker	059639	059639

E3H/E MS 20

Fixed (F)

Icw (1 s) = 30 kA

HR = Horizontal rear terminals

Circuit-breaker code	059025	059027
Additional code to be specified with the circuit-breaker	059640	059640

E3H/E MS 25

Fixed (F)

Icw (1 s) = 30 kA

HR = Horizontal rear terminals

Circuit-breaker code	059026	059028
Additional code to be specified with the circuit-breaker	059641	059641

E3H/E MS 32

Fixed (F)

Icw (1 s) = 30 kA

HR = Horizontal rear terminals

Circuit-breaker code	059029	059030
Additional code to be specified with the circuit-breaker	059642	059642

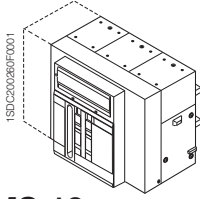

1SDA.....R1
3 Poles 4 Poles

E3H/E MS 12

Withdrawable (W) - MP

Icw (1 s) = 30 kA

MP = Moving part		
Circuit-breaker code	059031	059032
Additional code to be specified with the circuit-breaker	059638	059638

E3H/E MS 16

Withdrawable (W) - MP

Icw (1 s) = 30 kA

MP = Moving part		
Circuit-breaker code	059033	059034
Additional code to be specified with the circuit-breaker	059639	059639

E3H/E MS 20

Withdrawable (W) - MP

Icw (1 s) = 30 kA

MP = Moving part		
Circuit-breaker code	059035	059036
Additional code to be specified with the circuit-breaker	059640	059640

E3H/E MS 25

Withdrawable (W) - MP

Icw (1 s) = 30 kA

MP = Moving part		
Circuit-breaker code	059037	059038
Additional code to be specified with the circuit-breaker	059641	059641

E3H/E MS 32

Withdrawable (W) - MP

Icw (1 s) = 30 kA

MP = Moving part		
Circuit-breaker code	059039	059040
Additional code to be specified with the circuit-breaker	059642	059642



Ordering codes

SACE Emax switch-disconnectors
for applications up to 1150V AC

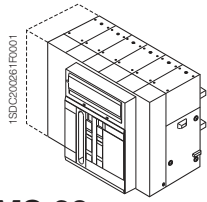

E4H/E MS 32

I_{cw} (1 s) = 65 kA

1SDA.....R1

059643

Note: to be specified in addition to the code of the standard version E4H/MS 32 circuit-breaker (U_e=690 V AC) page 9/32

E4H/E MS 40

I_{cw} (1 s) = 65 kA

059644

Note: to be specified in addition to the code of the standard version E4H/MS 40 circuit-breaker (U_e=690 V AC) page 9/32

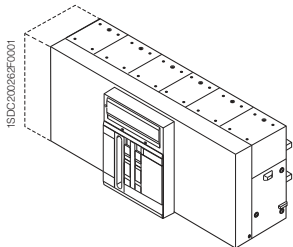

E6H/E MS 40

I_{cw} (1 s) = 65 kA

1SDA.....R1

058550

Note: to be specified in addition to the code of the standard version E6H/MS 40 circuit-breaker (U_e=690 V AC) page 9/33

E6H/E MS 50

I_{cw} (1 s) = 65 kA

058551

Note: to be specified in addition to the code of the standard version E6H/MS 50 circuit-breaker (U_e=690 V AC) page 9/33

E6H/E MS 63

I_{cw} (1 s) = 65 kA

058552

Note: to be specified in addition to the code of the standard version E6H/MS 63 circuit-breaker (U_e=690 V AC) page 9/33

Ordering codes

SACE Emax switch-disconnectors
for applications up to 1000V DC

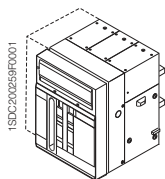

1SDA.....R1	4 Poles
3 Poles	1000V DC
750V DC	

E1B/E MS 08

Fixed (F)

I_{cw} (1 s) = **20 kA**

HR = Horizontal rear terminals

059041	059042
--------	--------

E1B/E MS 12

Fixed (F)

I_{cw} (1 s) = **20 kA**

HR = Horizontal rear terminals

059043	059044
--------	--------

E1B/E MS 08

Withdrawable (W) -
MP

I_{cw} (1 s) = **20 kA**

MP = Moving part

059045	059046
--------	--------

E1B/E MS 12

Withdrawable (W) -
MP

I_{cw} (1 s) = **20 kA**

MP = Moving part

059047	059048
--------	--------



Ordering codes

SACE Emax switch-disconnectors
for applications up to 1000V DC

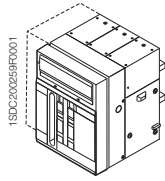

1SDA.....R1	4 Poles
3 Poles	1000V DC
750V DC	

E2N/E MS 12

Fixed (F)

Icw (1 s) = 25 kA

HR = Horizontal rear terminals

059049	059050
--------	--------

E2N/E MS 16

Fixed (F)

Icw (1 s) = 25 kA

HR = Horizontal rear terminals

059051	059052
--------	--------

E2N/E MS 20

Fixed (F)

Icw (1 s) = 25 kA

HR = Horizontal rear terminals

059053	059054
--------	--------

E2N/E MS 12

Withdrawable (W) -
MP

Icw (1 s) = 25 kA

MP = Moving part

059055	059056
--------	--------

E2N/E MS 16

Withdrawable (W) -
MP

Icw (1 s) = 25 kA

MP = Moving part

059057	059058
--------	--------

E2N/E MS 20

Withdrawable (W) -
MP

Icw (1 s) = 25 kA

MP = Moving part

059059	059060
--------	--------

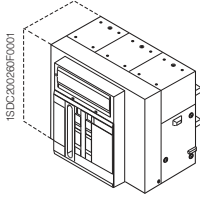

1SDA.....R1	
3 Poles	4 Poles
750V DC	1000V DC

E3H/E MS 12

Fixed (F)

I_{cw} (1 s) = 40 kA

HR = Horizontal rear terminals

059061 059062

E3H/E MS 16

Fixed (F)

I_{cw} (1 s) = 40 kA

HR = Horizontal rear terminals

059063 059064

E3H/E MS 20

Fixed (F)

I_{cw} (1 s) = 40 kA

HR = Horizontal rear terminals

059065 059066

E3H/E MS 25

Fixed (F)

I_{cw} (1 s) = 40 kA

HR = Horizontal rear terminals

059067 059068

E3H/E MS 32

Fixed (F)

I_{cw} (1 s) = 40 kA

HR = Horizontal rear terminals

059069 059070

E3H/E MS 12

Withdrawable (W) - MP

I_{cw} (1 s) = 40 kA

MP = Moving part

059071 059072

E3H/E MS 16

Withdrawable (W) - MP

I_{cw} (1 s) = 40 kA

MP = Moving part

059073 059074

E3H/E MS 20

Withdrawable (W) - MP

I_{cw} (1 s) = 40 kA

MP = Moving part

059075 059076

E3H/E MS 25

Withdrawable (W) - MP

I_{cw} (1 s) = 40 kA

MP = Moving part

059077 059078

E3H/E MS 32

Withdrawable (W) - MP

I_{cw} (1 s) = 40 kA

MP = Moving part

059079 059080



Ordering codes

SACE Emax switch-disconnectors
for applications up to 1000V DC

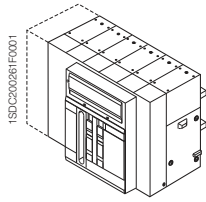

1SDA.....R1	
3 Poles	4 Poles
750V DC	1000V DC

E4H/E MS 32

Fixed (F)

Icw (1 s) = 65 kA

HR = Horizontal rear terminals

	059081	058911
--	--------	--------

E4H/E MS 40

Fixed (F)

Icw (1 s) = 65 kA

HR = Horizontal rear terminals

	059082	058913
--	--------	--------

E4H/E MS 32

Withdrawable (W) -
MP

Icw (1 s) = 65 kA

MP = Moving part

	059083	058912
--	--------	--------

E4H/E MS 40

Withdrawable (W) -
MP

Icw (1 s) = 65 kA

MP = Moving part

	059084	058914
--	--------	--------

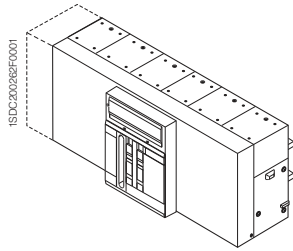

1SDA.....R1	
3 Poles	4 Poles
750V DC	1000V DC

E6H/E MS 40

Fixed (F)

I_{cw} (1 s) = 65 kA

HR = Horizontal rear terminals

058915	058921
--------	--------

E6H/E MS 50

Fixed (F)

I_{cw} (1 s) = 65 kA

HR = Horizontal rear terminals

058917	058923
--------	--------

E6H/E MS 63

Fixed (F)

I_{cw} (1 s) = 65 kA

HR = Horizontal rear terminals

058919	058925
--------	--------

E6H/E MS 40

Withdrawable (W) - MP

I_{cw} (1 s) = 65 kA

MP = Moving part

058916	058922
--------	--------

E6H/E MS 50

Withdrawable (W) - MP

I_{cw} (1 s) = 65 kA

MP = Moving part

058918	058924
--------	--------

E6H/E MS 63

Withdrawable (W) - MP

I_{cw} (1 s) = 65 kA

MP = Moving part

058920	058926
--------	--------



Ordering codes

SACE Emax CS sectionalizing trucks

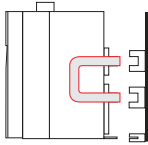

1SDA.....R1	
3 Poles	4 Poles

E1/CS 12

Withdrawable (W) - MP

MP = Moving part		
	059085	059086

E2/CS 20

Withdrawable (W) - MP

MP = Moving part		
	059087	059088

E3/CS 32

Withdrawable (W) - MP

MP = Moving part		
	059089	059090

E4/CS 40

Withdrawable (W) - MP

MP = Moving part		
	059091	059092

E6/CS 63

Withdrawable (W) - MP

MP = Moving part		
	059093	059094

Ordering codes

SACE Emax MTP earthing switches with making capacity

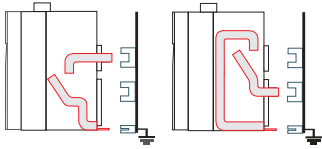

Earthing of upper terminals		Earthing of lower terminals	
-----------------------------	--	-----------------------------	--

1SDA.....R1
3 Poles

4 Poles

1SDA.....R1
3 Poles

4 Poles

E1 MTP 12

Withdrawable (W) - MP

MP = Moving part

059095

059097

059096

059098

E2 MTP 20

Withdrawable (W) - MP

MP = Moving part

059099

059101

059100

059102

E3 MTP 32

Withdrawable (W) - MP

MP = Moving part

059103

059105

059104

059106

E4 MTP 40

Withdrawable (W) - MP

MP = Moving part

059107

059109

059108

059110

E6 MTP 63

Withdrawable (W) - MP

MP = Moving part

059111

059113

059112

059114



Ordering codes

SACE Emax MT earthing trucks

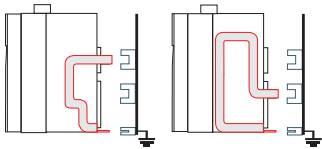

Earthing of upper terminals

1SDA.....R1
3 Poles 4 Poles

Earthing of lower terminals

1SDA.....R1
3 Poles 4 Poles

E1 MT 12

Withdrawable (W) - MP

MP = Moving part

059115	059117	059116	059118
--------	--------	--------	--------

E2 MT 20

Withdrawable (W) - MP

MP = Moving part

059119	059121	059120	059122
--------	--------	--------	--------

E3 MT 32

Withdrawable (W) - MP

MP = Moving part

059123	059125	059124	059126
--------	--------	--------	--------

E4 MT 40

Withdrawable (W) - MP

MP = Moving part

059127	059129	059128	059130
--------	--------	--------	--------

E6 MT 63

Withdrawable (W) - MP

MP = Moving part

059131	059133	059132	059134
--------	--------	--------	--------

Ordering codes

SACE Emax FP fixed parts

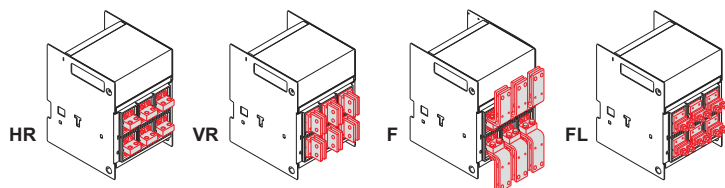

		750 V DC	1000 V DC
1SDA.....R1	3 Poles	1SDA.....R1	3 Poles
	4 Poles		4 Poles

E1

Withdrawable (W) - FP

FP = Fixed part

HR	059666	059762	059890	059902
VR	059672	059770	059894	059905
F	059678	059778		
FL	059684	059786	059898	059908
HR-VR	059690	059794		
VR-HR	059708	059818		

E2

Withdrawable (W) - FP

FP = Fixed part

HR	059667	059763	059891	059903
VR	059673	059771	059895	059906
F	059679	059779		
FL	059685	059787	059899	059909
HR-VR	059691	059795		
VR-HR	059709	059819		

E2S

Withdrawable (W) - FP

FP = Fixed part

HR	059668	059764		
VR	059674	059772		
F	059680	059780		
FL	059686	059788		
HR-VR	059692	059796		
VR-HR	059710	059820		

E3

Withdrawable (W) - FP

FP = Fixed part

HR	059669	059765	059892	059904
VR	059675	059773	059896	059907
F	059681	059781		
FL	059687	059789	059900	059910
HR-VR	059693	059797		
VR-HR	059711	059821		

E4

Withdrawable (W) - FP

FP = Fixed part

HR	059670	059766	059893	059136
VR	059676	059774	059897	059137
F	059682	059782		
FL	059688	059790	059901	059138
HR-VR	059694	059798		
VR-HR	059712	059822		

E4/f

Withdrawable (W) - FP

FP = Fixed part

HR		059767		
VR		059775		
F		059783		
FL		059791		
HR-VR		059799		
VR-HR		059823		

Note: HR-VR = Upper HR terminals, lower VR terminals;
VR-HR = Upper VR terminals, lower HR terminals.



Ordering codes

SACE Emax FP fixed parts

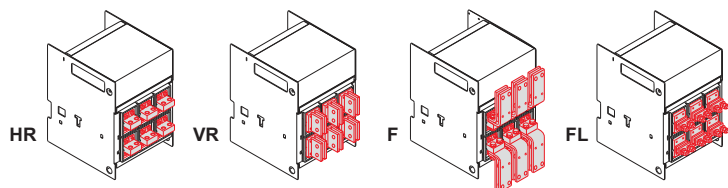

		750 V DC	1000 V DC
1SDA.....R1	3 Poles	1SDA.....R1	3 Poles
	4 Poles		4 Poles

E6

Withdrawable (W) - FP

FP = Fixed part				
HR	059671	059768	059139	059142
VR	059677	059776	059140	059143
F	059683	059784		
FL	059689	059792	059141	059144
HR-VR	059695	059800		
VR-HR	059713	059824		

E6/f

Withdrawable (W) - FP

FP = Fixed part	
HR	059769
VR	059777
F	059785
FL	059793
HR-VR	059801
VR-HR	059825

Note: HR-VR = Upper HR terminals, lower VR terminals;
VR-HR = Upper VR terminals, lower HR terminals.

Ordering codes

Conversion kit for fixed circuit-breaker and fixed parts

Conversion kit for fixed circuit- breaker and fixed parts

1SDA.....R1
3 Poles 4 Poles

Kit for converting fixed circuit-breaker with horizontal rear terminals to vertical rear terminals

E1	038052	038057
E2	038053	038058
E3	038054	038059
E4	038055	038060
E6	038056	038061
E4/f	–	048719
E6/f	–	050833

Note: Each kit is prepared for top or bottom application. For conversion of a complete circuit-breaker, order 2 kits.
Extracode 1SDA050230R1 to be specified in case of 1/2 terminal kit (HR) standard.

Kit for converting fixed circuit-breaker with horizontal rear terminals to front terminals

E1	038062	038067
E2	038063	038068
E3	038064	038069
E4	038065	038070
E6	038066	038071
E4/f	–	048720
E6/f	–	050834

Note: Each kit is prepared for top or bottom application. For conversion of a complete circuit-breaker, order 2 kits.
Extracode 1SDA050230R1 to be specified in case of 1/2 terminal kit (HR) standard.

Kit for converting fixed parts with horizontal rear terminals to front terminals

E1	038062	038067
E2	045031	045035
E3	045032	045036
E4	045033	045037
E6	045034	045038
E4/f	–	048718
E6/f	–	050837

Note: Each kit is prepared for top or bottom application. For conversion of a complete fixed part, order 2 kits. To be specified as spare parts.

Kit for converting fixed parts with horizontal rear terminals to vertical rear terminals

E1	055481	055486
E2	055482	055487
E3	055483	055488
E4	055484	055489
E6	055485	055490
E4/f	–	058537
E6/f	–	058538

Note: Each kit is prepared for top or bottom application. For conversion of a complete fixed part, order 2 kits. To be specified as spare parts.

Kit for converting fixed parts with vertical rear terminals to horizontal rear terminals

E1	055491	055496
E2	055492	055497
E3	055493	055498
E4	055494	055499
E6	055495	055500
E4/f	–	058539
E6/f	–	058540

Note: Each kit is prepared for top or bottom application. For conversion of a complete fixed part, order 2 kits. To be specified as spare parts.

Kit for converting fixed part from previous versions to new versions

E1/E6	059645	059645
-------	--------	--------



Ordering codes

Extra codes

1SDA.....R1

Extra codes for rating plug

To be specified with the code of the standard version circuit-breaker

E1-E3	In = 400A	058235
E1-E3	In = 630A	058236
E1-E6	In = 800A	058237
E1-E6	In = 1000A	058238
E1-E6	In = 1250A	058240
E1-E6	In = 1600A	058241
E2-E6	In = 2000A	058242
E3-E6	In = 2500A	058243
E3-E6	In = 3200A	058245
E4-E6	In = 4000A	058247
E6	In = 5000A	058248
E6	In = 6300A	058249
E1-E3	In = 400A for Rc protection *	063895
E1-E3	In = 630A for Rc protection *	063896
E1-E3	In = 800A for Rc protection *	063897
E1-E3	In = 1250A for Rc protection *	063898
E2-E3	In = 2000A for Rc protection *	063899
E2	In = 3200A for Rc protection *	063900

* for PR122/P LSIRc or PR123/P LSIG and toroid for residual current protection.

Extra code for connection of voltage measurement

To be specified with PR122/P and PR123/P when the input for voltage measurement in terminal box/sliding contacts instead of internal connection on the bottom terminals is required

PR120/V	- External measurements	058250
PR120/V	- Internal connection on the upper terminals	058251

Ordering codes

SACE Emax accessories

1SDA....R1

Electrical accessories



Shunt opening release - YO (1a)

E1/6	24V DC	038286
E1/6	30V AC / DC	038287
E1/6	48V AC / DC	038288
E1/6	60V AC / DC	038289
E1/6	110...120V AC / DC	038290
E1/6	120...127V AC / DC	038291
E1/6	220...240V AC / DC	038292
E1/6	240...250V AC / DC	038293
E1/6	380...400V AC	038294
E1/6	440...480V AC	038295

Note: The shunt opening release (YO) and closing release (YC) share the same construction and are therefore interchangeable. Their function is determined by the position in which they are mounted on the circuit-breaker.

Second shunt opening release - YO2 (1a)

E1/6	24V DC	050157
E1/6	30V AC / DC	050158
E1/6	48V AC / DC	050159
E1/6	60V AC / DC	050160
E1/6	110...120V AC / DC	050161
E1/6	120...127V AC / DC	050162
E1/6	220...240V AC / DC	050163
E1/6	240...250V AC / DC	050164
E1/6	380...400V AC	050165
E1/6	440...480V AC	050166

Note: supplied with special release support.

Shunt closing release - YC (1a)

E1/6	24V DC	038296
E1/6	30V AC / DC	038297
E1/6	48V AC / DC	038298
E1/6	60V AC / DC	038299
E1/6	110...120V AC / DC	038300
E1/6	120...127V AC / DC	038301
E1/6	220...240V AC / DC	038302
E1/6	240...250V AC / DC	038303
E1/6	380...400V AC	038304
E1/6	440...480V AC	038305

Note: The shunt opening release (YO) and closing release (YC) share the same construction and are therefore interchangeable. Their function is determined by the position in which they are mounted on the circuit-breaker.

SOR Test Unit - (1b)

E1/6	050228
------	--------



Ordering codes

SACE Emax accessories

1SDA.....R1



Undervoltage release - YU (2a)

E1/6	24V DC	038306
E1/6	30V AC / DC	038307
E1/6	48V AC / DC	038308
E1/6	60V AC / DC	038309
E1/6	110...120V AC / DC	038310
E1/6	120...127V AC / DC	038311
E1/6	220...240V AC / DC	038312
E1/6	240...250V AC / DC	038313
E1/6	380...400V AC	038314
E1/6	440...480V AC	038315



Electronic time-delay device for undervoltage release - D (2b)

E1/6	24...30V DC	038316
E1/6	48V AC / DC	038317
E1/6	60V AC / DC	038318
E1/6	110...127V AC / DC	038319
E1/6	220...250V AC / DC	038320



Geared motor for the automatic charging of the closing springs - M (3)

E1/6	24...30V AC / DC	038321
E1/6	48...60V AC / DC	038322
E1/6	100...130V AC / DC	038323
E1/6	220...250V AC / DC	038324
E1/6	24...30V AC / DC + MC 24Vdc for digital signals	066050
E1/6	48...60V AC / DC + MC 24Vdc for digital signals	066051
E1/6	100...130V AC / DC + MC 24Vdc for digital signals	066052
E1/6	220...250V AC / DC + MC 24Vdc for digital signals	066053

Note: supplied as standard with limit contact and microswitch to signal when the closing springs are charged (accessory 5d).

Electrical signalling of overcurrent releases tripped - (4a)

E1/6	058260
------	--------

Electrical signalling of overcurrent releases tripped with remote reset command - (4b)

E1/6	220...240V AC/DC	058261
E1/6	110...130V AC/DC	058262
E1/6	24...30V AC/DC	058263

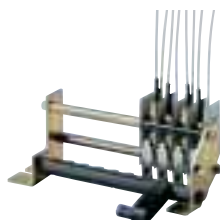

Electrical signalling of circuit-breaker open/closed - Q1 ... 10 - (5a)

E1/6 - PR121/P	4 auxiliary contacts	038326 (a)
E1/6 - PR121/P	4 auxiliary contacts for digital signals	050153
E1/6 - PR121/P	10 auxiliary contacts (installed)	046523 (b)
E1/6 - PR121/P	10 auxiliary contacts (not installed)	038327 (c)
E1/6 - PR121/P	10 auxiliary contacts for digital signals	050152
E1/6 - PR122-3/P	4 auxiliary contacts (2NO+2NC+2PR122-3)	058264 (d)
E1/6 - PR122-3/P	4 auxiliary contacts (2NO+2NC+2PR122-3) for digital signals	058265
E1/6 - PR122-3/P	10 auxiliary contacts (5NO+5NC+2PR122-3 - installed)	058267 (b)
E1/6 - PR122-3/P	10 auxiliary contacts (5NO+5NC+2PR122-3 - not installed)	058266 (c)
E1/6 - PR122-3/P	10 auxiliary contacts (5NO+5NC+2PR122-3) for digital signals	058268
E1/6 MS - E1/6 MTP	4 auxiliary contacts	038326
E1/6 MS - E1/6 MTP	4 auxiliary contacts for digital signals	050153
E1/6 MS - E1/6 MTP	10 auxiliary contacts	038327
E1/6 MS - E1/6 MTP	10 auxiliary contacts for digital signals	050152

Note: (a) Already included with automatic circuit-breakers c/w PR121/P. Can be ordered as loose accessories.
 (b) Can only be ordered mounted with automatic circuit-breakers.
 (c) Can only be ordered loose in the case of automatic circuit-breakers.
 (d) Already included for circuit-breakers with PR122/P e PR123/P. Can only be ordered as loose accessories.

External supplementary of circuit-breaker open/closed auxiliary contacts - Q11 ... 25 - (5b)

E1/6	15 supplementary auxiliary contacts (for fixed / withdrawable racked-in)	043475 (a)
E1/6	15 supplementary auxiliary contacts (for withdrawable racked-in / test isolated)	048827
E1/6	15 supplementary auxiliary contacts for digital signals (for fixed / withdrawable racked-in)	050145 (a)
E1/6	15 supplementary auxiliary contacts for digital signals (for withdrawable racked-in / test isolated)	050151

Note: outside the circuit-breaker. Order as an alternative to the various types of mechanical interlocks (accessory 10) and mechanical compartment door lock (accessory 8f).

(a) For mounting on fixed circuit-breaker requires accessory 10.4 as well (Interlock plate for fixed circuit-breaker).



1SDA....R1
3 Poles 4 Poles

Electrical signalling of circuit-breaker racked-in/test isolated/racked-out S75 - (5c)

E1/6	5 auxiliary contacts	038361	038361
E1-E2	10 auxiliary contacts*	038360	043467
E3	10 auxiliary contacts*	043468	043469
E4-E6	10 auxiliary contacts*	043470	043470
E1/6	5 auxiliary contacts for digital signals	050146	050146
E1-E2	10 auxiliary contacts for digital signals*	050147	050148
E4-6	10 auxiliary contacts for digital signals*	050147	050147
E3	10 auxiliary contacts for digital signals*	050149	050150

* unfitting with PR120/K



Contact for signalling closing spring charged S33 M/2- (5d)

E1/6	038325
------	--------

Note: already supplied with the geared motor for automatic closing spring charging.



Contact for signalling undervoltage release de-energized - (5e)

E1/6	1 normally-closed contact	038341
E1/6	1 normally-open contact	038340



Ordering codes

SACE Emax accessories

1SDA.....R1



Current sensor for neutral conductor outside circuit-breaker UI/N - (6a)

E1-E2-E4	I _n N = 2000A	058191
E3-E6	I _n N = 3200A	058218
E4/f ⁽¹⁾	I _n N = 4000A	058216
E6/f ⁽²⁾	I _n N = 6300A	058220

Note: I_n N refers to the maximum neutral conductor capacity.
 (1) also for E1-E2 with setting of the neutral N_e = 200%
 (2) also for E3 with setting of the neutral N_e = 200%



Homopolar toroid for the main power supply earthing conductor (star centre of the transformer) UI/O - (6b)

E1/6	059145
------	--------



Toroid for residual current protection ⁽¹⁾ - (6c)

Rc Toroid for E1-E2 3p	063869
Rc Toroid for E1-E2 4p, E3 3p	064553

Note: (1) see page 4/12 and 4/25.

Mechanical accessories

Mechanical operation counter - (7)

E1/6	038345
------	--------

Lock in open position - (8a-8b)

key locks (8a)

E1/6	for 1 circuit-breaker (different keys)	058271
E1/6	for groups of circuit-breakers (same keys N.20005)	058270
E1/6	for groups of circuit-breakers (same keys N.20006)	058274
E1/6	for groups of circuit-breakers (same keys N.20007)	058273
E1/6	for groups of circuit-breakers (same keys N.20008)	058272
E1/6	for groups of circuit-breakers (same keys N.20009)	064503

padlocks (8b)

E1/6	ø 4 mm	038351 (a)
E1/6	ø 8 mm	064504

Note: (a) To be ordered as alternative to the opening and closing pushbutton protective cover (accessory 9a).





Circuit-breaker lock in racked-in/test isolated/racked-out position - (8c)

E1/6	for 1 circuit-breaker (different keys and padlock Ø 4mm)	058278
E1/6	for groups of circuit-breakers (same keys N.2005 and padlock Ø 4mm)	058277
E1/6	for groups of circuit-breakers (same keys N.2006 and padlock Ø 4mm)	058281
E1/6	for groups of circuit-breakers (same keys N.2007 and padlock Ø 4mm)	058280
E1/6	for groups of circuit-breakers (same keys N.2008 and padlock Ø 4mm)	058279
E1/6	for groups of circuit-breakers (same keys N.2009 and padlock Ø 4mm)	064505
E1/6	for 1 circuit-breaker (different keys N.2009 and padlock Ø 6mm)	064506
E1/6	for groups of circuit-breakers (same keys N.2005 and padlock Ø 6mm)	064507
E1/6	for groups of circuit-breakers (same keys N.2006 and padlock Ø 6mm)	064508
E1/6	for groups of circuit-breakers (same keys N.2007 and padlock Ø 6mm)	064509
E1/6	for groups of circuit-breakers (same keys N.2008 and padlock Ø 6mm)	064510
E1/6	for groups of circuit-breakers (same keys N.2009 and padlock Ø 6mm)	064511

Padlocks

E1/6	Ø 8mm	064512
------	-------	--------

Arrangement for key lock

RONIS

Provided cover	058315
Lock in open position	058276
Lock in racked-in/test isolated/racked-out position	058314

CASTELL

Lock in open position	058275
-----------------------	--------



Accessory for lock in test isolated/racked-out position - (8d)

E1/6	038357
------	--------

Note: Must always be ordered to complete the circuit-breaker lock in racked-in/test/racked-out position (accessory 8c)



Accessory for shutter padlock device - (8e)

E1/6	038363
------	--------

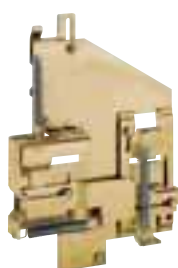

Mechanical compartment door lock - (8f)

E1/6	045039
------	--------

Note: – Order with interlock for fixed circuit-breaker/moving part of withdrawable circuit-breaker (accessory 10.3)
 – for fixed version, also order the interlock plate 10.4
 – order as an alternative to cable interlocks (accessory 10.1), and to the 15 supplementary auxiliary contacts (accessory 5b).



Ordering codes

SACE Emax accessories

1SDA.....R1



Protective cover for opening and closing pushbuttons - (9a)

E1/6		038343
------	--	--------

Note: Order as an alternative to the padlock device in open position (accessory 8b).



IP54 door protection - (9b)

E1/6	Different keys	038344
E1/6	Same keys	065622

Sealable relay protection - (9c)

E1/6 for PR121		058316
E1/6 for PR122/PR123		058317

Mechanical interlock - (10)

For instructions see pages 9/63 and following.

10.1 Interlock cables for fixed circuit-breakers or fixed parts

E1/6	A - horizontal	038329
E1/6	B - horizontal	038330
E1/6	C - horizontal	038331
E1/6	D - horizontal	038332
E1/6	A - vertical	038333
E1/6	B - vertical	038334
E1/6	C - vertical	038335
E1/6	D - vertical	038336
E1/6	Cables kit for interlock E1/6 - T7/X1	064568

Note: Order one type of cable for each interlock. Order on one of the fixed circuit-breakers or on one of the fixed parts.



Extended interlock cables for fixed circuit-breakers or fixed parts

E1/6	A - horizontal extended cables	066090
E1/6	B - horizontal extended cables	066091
E1/6	C - horizontal extended cables	066092
E1/6	D - horizontal extended cables	066093
E1/6	A - vertical extended cables	066094
E1/6	B - vertical extended cables	066095
E1/6	C - vertical extended cables	066096
E1/6	D - vertical extended cables	066097

1SDA.....R1
3 Poles 4 Poles

10.2 Interlock for fixed circuit-breaker/moving part of withdrawable circuit-breaker

E1-E2	038366	038366
E3	038367	038367
E4	038368	043466
E6	043466	038369

Note: Order one accessory for each fixed circuit-breaker/moving part of withdrawable circuit-breaker.

10.3 Interlock for fixed circuit-breaker/fixed part of withdrawable circuit-breaker

E1/6	Interlock A / B / D	038364
E1/6	Interlock C	038365

Note: Order one accessory for each fixed circuit-breaker/fixed part of withdrawable circuit-breaker.

10.4 Interlock plate for fixed circuit-breaker

E1/6		038358
------	--	--------

Note: Order only for fixed circuit-breaker.

Lift device - (11)

E2-E3	Lift device for E2 3/4p and E3 3p	068841
E3-E4	Lift device for E3 4p-E4 3/4p	068842
E4-E6	Lift device for E4/fs 4p-E6 3/4p+fs	068843

Auxiliary units



Automatic transfer switch ATS21 and ATS022 - (12)

E1/6	ATS021	065523
E1/6	ATS022	065524



PR010/T configuration test unit

E1/6	PR010/T	048964
------	---------	--------



PR021/K Signalling unit

E1/6	PR021/K	059146
------	---------	--------



PR120/K Signalling module

E1/6	PR120/K (4 Output with independent terminals)	058255
E1/6	PR120/K (4 Output + 1 Input with a common terminal)	058256

Note: Do not use with 10 electrical signalling of circuit-breaker open/closed.



PR120/V Voltage measuring module

E1/6	PR120/V	058252
------	---------	--------

Note: For the supply of circuit-breakers with connection on the upper terminals or terminal box, please see also the extra codes (page 9/54).



PR120/D-M Communication module (Modbus RTU)

E1/6	PR120/D-M	058254
------	-----------	--------



PR120/D-BT Internal wireless communication module

E1/6	PR120/D-BT	058257
------	------------	--------

BT030 USB External wireless communication module

E1/6	BT030 USB	058259
------	-----------	--------



Ordering codes

SACE Emax accessories



EP010 - ABB Fieldbus plug

E1/6	EP010	060198
------	-------	--------

Note: Do not use with FBP.PDP21, the FBP-PDP22 is required.

PR030/B - Power supply unit

E1/6	PR030/B	058258
------	---------	--------

Note: Standard supply with PR122 and PR123 trip units.

HMI030 - Interface from front of panel

E1/6	HMI030	063143
------	--------	--------



Flex Interface

Accessory Devices

E1/6	MM030	064268
E1/6	AD030 DO	064513
E1/6	AD030 AO	064572
E1/6	AD030 MI	064573

System Devices

E1/6	SD030 DX	064578
E1/6	SD030 D0	064514
E1/6	SD030 DI	064575
E1/6	SD030 AO	064576
E1/6	SD030 MI	064577

Local Devices

E1/6	LD030 DO	064574
------	----------	--------

Multimeter

E1/6	HMI030	063143
------	--------	--------

Ordering codes

Electronic trip units and current sensors (for loose supplies)



Electronic trip units

LI	058189	058196	
LSI	058193	058197	058199
LSIG	058195	058198	058200
LSIRc		058201	

Rating plug



		1SDA.....R1
E1-E3	In=400A	058192
E1-E3	In=630A	058221
E1-E6	In=800A	058222
E1-E6	In=1000A	058223
E1-E6	In=1250A	058225
E1-E6	In=1600A	058226
E2-E6	In=2000A	058227
E3-E6	In=2500A	058228
E3-E6	In=3200A	058230
E4-E6	In=4000A	058232
E6	In=5000A	058233
E6	In=6300A	058234
E1-E3	In=400A for Rc protection *	063889
E1-E3	In=630A for Rc protection *	063890
E1-E3	In=800A for Rc protection *	063891
E1-E3	In=1250A for Rc protection *	063892
E2-E3	In=2000A for Rc protection *	063893
E3	In=3200A for Rc protection *	063894

* for PR122/P LSIRc, PR122/P LSIG with PR120/V or PR123/P LSIG and toroid for residual current protection.



Ordering codes

Order examples

1) Extra codes

Instructions for ordering

Standard version Emax series circuit-breakers are identified by means of commercial codes that can be altered by adding the following variables:

- **Codes for Terminal Kits for fixed circuit-breakers (other than horizontal rear)**
- **Extra codes for Current Transformer Settings (for current values below rated)**
- **Extra codes for special Version for rated service voltages up to 1150V AC**

The above types of variables can also be requested simultaneously on the same circuit-breaker. The "Extra codes" indicate variables that are not in addition to, but in replacement of the those found in the basic circuit-breaker.

For this reason, these commercial codes can only be ordered installed on the circuit-breaker and not as loose parts.

For releases (which already include the Dialogue Unit) and Current Transformers for supplies as spare parts for replacement by the customer, please see the coding section "Protection Releases and Current Transformers which can be supplied separately".

Numerical examples

- **Terminal Kit Codes for fixed circuit-breaker (other than horizontal rear)**

The codes indicate 3 or 4 pieces (for mounting on top or bottom terminals).

To convert a complete circuit-breaker, in the order specify 2 identical kits or 2 different kits for mixed terminals.

For mixed solutions, the first code indicates the 3 or 4 terminals to be mounted above, while the second indicates the 3 or 4 terminals to be mounted below.

Example no. 1

Emax E3N 3 poles fixed with Vertical Rear terminals (VR)

1SDA038054R1 KIT 1/2 3p F HR>F VR E3

Example no. 2

Emax E3N 3 poles fixed with top Vertical Rear (VR) and bottom Front (F) terminals

1SDA038054R1 KIT 1/2 3p F HR>F VR E3

Example no. 3

Emax E3N 3 poles fixed with top Horizontal Rear terminals (HR) standard and bottom Vertical Rear terminals (VR)

1SDA050230R1 Kit 1/2 3p F HR

- **Extra codes for Current Transformer Settings (for current values below rated)**

Example no. 4

Emax E3N 3200 3 poles fixed In=2000A

1SDA058242R1 rating plug In=2000A E2-4IEC E3-4UL EX.C

- **Extra codes for Special Version for rated service voltages up to 1150V AC**

Example no. 5

Emax E3H/E 2000 3 poles fixed (version up to 1150V AC)

1SDA048534R1 Special 1150V AC version Emax E3H/E20 circuit-breaker

2) Mechanical interlocks

Instructions for ordering

All the mechanical interlocks for any type of SACE Emax circuit-breaker consist of various components, each of which has been coded to ensure the greatest possible flexibility of the accessory.

The accessory components are described below

- **Cables for interlock** (Ref. 10.1 page 9/59)

One type of cable must be ordered for each interlock.

Flexible cables must be fixed to the fixed circuit-breakers and to the switchgear structures using self-adhesive plates and self-locking bands.

- **Interlock for fixed circuit-breaker/withdrawable circuit-breaker moving part** (Ref. 10.2 page 9/59)

This is the accessory which must be installed on the moving part of the withdrawable circuit-breaker or on the side of the fixed circuit-breaker.

This accessory must be ordered for each fixed circuit-breaker and for each moving part of the withdrawable circuit-breaker.

- **Interlock for fixed circuit-breaker/ withdrawable circuit-breaker fixed part** (Ref. 10.3 page 9/59)

This is the accessory which must be installed on the fixed part of the withdrawable circuit-breaker or on the interlock plate of the fixed circuit-breaker (which simulates the fixed part of the withdrawable circuit-breaker).

This accessory must be ordered for each fixed circuit-breaker and for each fixed part of the withdrawable circuit-breaker.

- **Interlock plate for fixed circuit-breaker** (Ref. 10.4 page 9/59)

This must be requested for each fixed circuit-breaker present in the interlock.

For each circuit-breaker used in the interlock, depending on the type of circuit-breaker, the accessories listed in the figures below must be ordered (see page 9/55).

A single group of cables ("Cables for interlock" ref. 10.1) must be ordered **for each interlock**. In particular, either on a fixed circuit-breaker or on one of the fixed parts must be specified.

The examples beside show a general guide to the types of accessories that must be ordered for the various versions of circuit-breakers and type of interlock:

1. Interlock between two fixed circuit-breakers

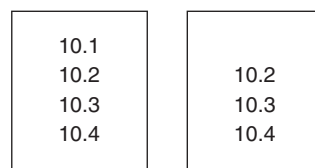

3. Interlock between three fixed circuit-breakers

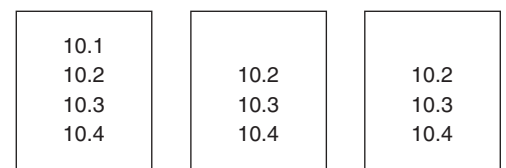

2. Interlock between two withdrawable circuit-breakers

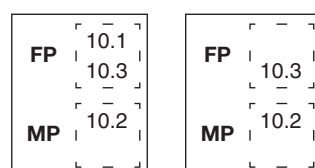

4. Interlock between three withdrawable circuit-breakers

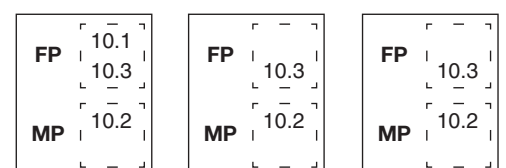



Ordering codes

Order examples

Numerical examples

Example no. 5

An interlock is to be made between two type A circuit-breakers. In particular, the following are to be interlocked:

- a SACE E3 3-pole fixed circuit-breaker
 - with a SACE E4 4-pole withdrawable circuit-breaker;
- the circuit-breakers are placed horizontally in the switchboard.

The codes to be used when ordering are listed below:

Pos	Code	Description
100	SACE E3 fixed circuit-breaker	
	1SDA038329R1	Type A interlock cables for fixed circuit-breakers or fixed parts - horizontal E1/6
	1SDA038367R1	Interlock for fixed circuit-breaker/moving part of withdrawable circuit-breaker E3
	1SDA038364R1	Interlock for fixed circuit-breaker/fixed part of withdrawable circuit-breaker Interlock typeA / B / D E1/6
	1SDA038358R1	Interlock plate for fixed circuit-breaker E1/6
200	SACE E4 moving part of withdrawable circuit-breaker	
	1SDA043466R1	Interlock for fixed circuit-breaker/moving part of withdrawable circuit-breaker 4p E4 / 3p E6
300	Fixed part SACE E4	
	1SDA038364R1	Interlock for fixed circuit-breaker/fixed part of withdrawable circuit-breaker Interlock TypeA / B / D E1/6

Example no. 6

Here an interlock is to be made between three Type C vertical circuit-breakers with the following circuit-breakers:

- SACE E2 3-pole withdrawable circuit-breaker
- SACE E3 3-pole fixed circuit-breaker
- SACE E6 4-pole fixed circuit-breaker.

Pos	Code	Description
100	SACE E2 Moving Part of withdrawable circuit-breaker	
	1SDA038366R1	Interlock for fixed circuit-breaker/moving part of withdrawable circuit-breaker E1-E2
200	SACE E2 Fixed part	
	1SDA038335R1	Type C interlock cables for fixed circuit-breakers or fixed parts - vertical E1/6
	1SDA038365R1	Interlock for fixed circuit-breaker/fixed part of withdrawable circuit-breaker Type C Interlock E1/6
300	SACE E3 Fixed circuit-breaker	
	1SDA038367R1	Interlock for fixed circuit-breaker/moving part of withdrawable circuit-breaker Interlock E3
	1SDA038365R1	Interlock for fixed circuit-breaker/fixed part of withdrawable circuit-breaker Type C Interlock E1/6
	1SDA038358R1	Interlock plate for fixed circuit-breaker E1/6
400	SACE E6 Fixed circuit-breaker	
	1SDA038369R1	Interlock for fixed circuit-breaker/moving part of withdrawable circuit-breaker Interlock 4p E6
	1SDA038365R1	Interlock for fixed circuit-breaker/fixed part of withdrawable circuit-breaker Type C Interlock E1/6
	1SDA038358R1	Interlock plate for fixed circuit-breaker E1/6

Contact us

ABB SACE

A division of ABB S.p.A.

L.V. Breakers

Via Baioni, 35

24123 Bergamo - Italy

Phone: +39 035 395 111

Fax: +39 035 395306-433

www.abb.com

The data and illustrations are not binding. We reserve the right to modify the contents of this document on the basis of technical development of the products, without prior notice.

Copyright 2010 ABB. All rights reserved.

1SDC200006D0207 - 03/2010 - 6.000 - CAL