

A Spectrum of Benefits ...



Onload Changeover Switch

ABOUT US



Switchgear Factory, Navi Mumbai



Switchgear Factory, Ahmednagar



Switchgear Factory, Vadodara

L&T Electrical & Automation (E&A) is a market leader for electrical distribution, monitoring and control solutions in the low voltage category.

Popular among customers as L&T Switchgear, E&A offers a wide range of low and medium voltage switchgear, motor starters, electrical systems, industrial automation, building electrical solutions, energy management solutions, electrical modernization solutions and metering solutions. Its products and solutions cater to key sectors of economy like industries, utilities, infrastructure, building and agriculture.

E&A's manufacturing operations at Navi Mumbai, Ahmednagar, Vadodara, Coimbatore and Mysuru in India adhere to global practices of excellence and receive support from well-equipped in-house design and development centres as well as tooling facilities that contribute to precision in manufacturing.

INDEX

Overview 2 - 5

Product Data 6 - 26

Wiring Diagrams 27 - 29

Characteristic Curves 30 - 33

Dimensions 34 - 52

Standards & Approvals

CO range of Changeover Switches comply with the following standards

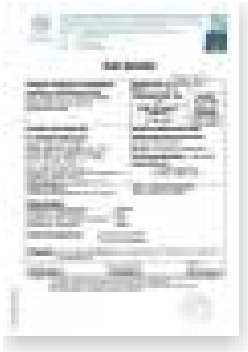

- **IEC 60947-1, EN 60947-1, IS/IEC 60947-1**
Low-voltage switchgear and controlgear, Part 1: General Rules
- **IEC 60947-3, EN 60947-3, IS/IEC 60947-3**
Low-voltage switchgear and controlgear, Part 3: Switches, disconnectors, switch-disconnectors and fuse combination units

Third party certificates (ERDA / CPRI) available for CO range of changeover switches

NABL



NABL accreditation is a formal recognition of the technical competence of testing, calibration or medical laboratory for a specific task following ISO/IEC 17025:2005 Standard. Accredited laboratories have the responsibility of satisfying the criteria of laboratory accreditation at all times, which are verified during Surveillance and Reassessment visits by NABL. Further the accredited laboratories should prove their technical competence by satisfactory participation in recognized Proficiency Testing Programmes.

E&A's Switchgear Testing Lab is NABL accredited subject to continued satisfactory compliance to above standard & additional requirements of NABL.

The CO range of Changeover switches are tested in E&A's NABL accredited Switchgear Testing Lab.

CE Marking



A CE marking is a European marking of conformity that indicates a product complies with the essential requirements of the applicable European laws or directives with respect to safety, health and environment and consumer protection. Generally, this conformity to the applicable directives is done through self-declaration and is required on products in the countries of the European Economic Area (EEA) to facilitate trade among the member countries. The manufacturer or their authorized representative established in the EEA is responsible for affixing the CE marking to their product. The CE marking provides a means for a manufacturer to demonstrate that a product complies with a common set of laws required by all countries in the EEA to allow free movement of trade within the EEA countries.

E&A's CO range of Changeover switches conform to the Low voltage directive 73/23/EEC as amended by directive 93/68/EEC, provided it is used in the application for which it is made and is installed and maintained in accordance with professional practices with relevant installation standards and operating instructions.

RoHS Compliance



As a green initiatives, L&T Electrical & Automation (E&A) understands the requirements of the RoHS directive. The directive restricts the use of hazardous substances in electrical and electronic equipment and bans electrical equipment containing more than permitted levels of lead, cadmium, mercury, hexavalent chromium, polybrominated biphenyl (PBB) and polybrominated diphenyl ether (PBDE) flame retardants.



Overview

- Basic Function 03
- Superior Performance 04
- Product Range 05

Changeover Switches

L&T Electrical & Automation (E&A) offers you a unique series of Changeover Switches combining compactness with high performance & customer convenience, thus, making it a state-of-the-art product in changeover technology.

The CO range covers ratings from 63 A to 2000 A in 6 frame sizes. These changeover switches are available in open execution, Sheet steel enclosure, fused version (suitable for DIN type fuse - link), motorised version & Enclosed ATS version.

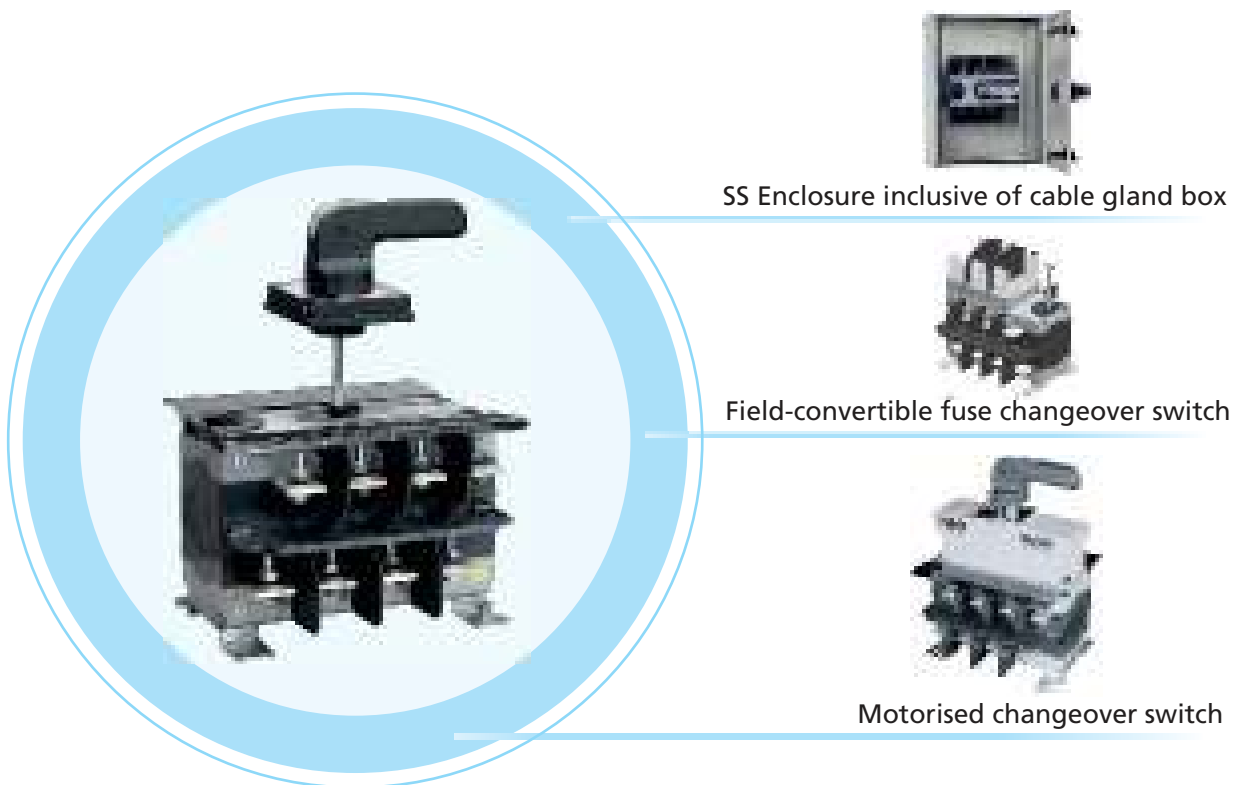

Basic function of Changeover Switches

Onload Changeover S-D has 3 stable positions as defined below

POSITION I	POSITION O	POSITION II
Switch is in ON position with normal supply available at the outgoing terminals.	Switch is in OFF position & outgoing terminals are isolated from both supplies (normal & alternate supplies)	Switch is in ON position with alternate supply available at the outgoing terminals.

Onload Changeover S-D consists of two separate sets of terminals for incoming supplies and a set of output terminals to connect the common load. Thus, changeover switch ensures continuity of supply to the load by alternating between normal and alternate supply.

Superior Performance

Higher short-time withstand Capacity

Contact system is of double break, knife type having self wiping action with electrodynamic compensation. This ensures reliable performance during normal as well as short circuit fault conditions, offering higher short-time withstand rating.

Higher life

Changeover switch offers high electrical and mechanical life in compact frame sizes. The electrical and mechanical life are two times the requirement of the standard.

Total flexibility of connection

Factory fitted external shorting links can be easily removed and fitted on the other side as required at site (125 A to 2000 A). This gives more flexibility at the time of installation. For Frame 1(63A, 100A & 125A), CAT no.s for top and bottom shorting links are available.

Maximum termination capacity

Changeover Switch provides generous terminal capacity in its compact size, facilitating aluminium termination.

Higher ground clearance

Higher ground clearance between terminals and mounting base plate ensures adequate clearance even after connecting cables. This eliminates the possibility of phase to ground flash over.

Total safety

Changeover Switch provides complete safety by providing terminal shrouds, source separator and inter-phase barriers.

Product Range

Onload Changeover S-Ds are available from 63 A to 2000 A. The range is covered through 6 frames as shown below.

Frame No.	Ratings (A)		
I	63	100	125
II	125	160	200
III	250	315	
IV	400	630	
V	630	800	1000
VI	1250	1600	2000

Versions

Changeover Switches are available in open execution, Sheet steel enclosure, fused version and motorised version.

- Changeover S-D suitable for open execution**
Changeover S-D, which can be commissioned in panels are of open execution type and provide IP20 protection from front.
- Onload changeover S-D in SSenclosures**
Onload Changeover S-Ds are available in sheet steel enclosure with adequate space for cable terminations so that additional cable entry boxes are not required.
Cable gland plates are also provided with the switch. Enclosure provides IP54 protection.
- Changeover S-D suitable for HRCfuses**
The Changeover S-Ds for open execution can be easily converted to fused version at site by using fuse conversion kit. It provides the benefits of overload and short circuit protection through the fastest switching device-fuse, and is suitable for cylindrical & knife type (DIN) fuse links. Use of E&A HF & HN fuse links reduces watt loss.
- Motorised Changeover S-D**
On load changeover S-Ds are available in motorised version with control voltage 240 V ac. There is no difference in product dimensions of manual and motorised changeover S-Ds (125 A to 2000 A).



Product Data

- Manual Changeover Product Feature 07
- Technical Specifications of
Manual Changeover 11
- Motorised Changeover Product Features 13
- Universal Mounting for
Manual Changeover Range 15
- Automatic Source Transfer Solution 16
- ASTS with AST Controller 17
- ASTS with AuXC 2000 Controller 19
- Technical Specifications of
Motorised Kit 21
- Enclosed ATS 23
- Ordering Information 26

Manual Changeover Product Feature

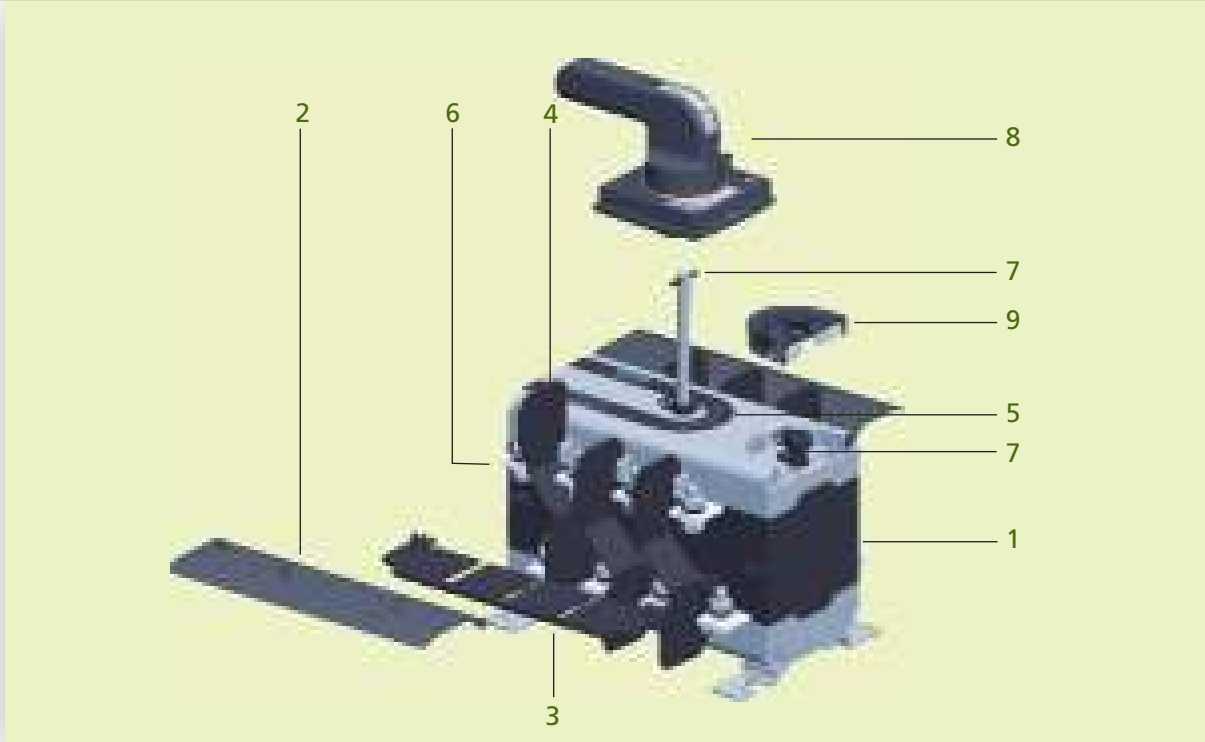

1. Mechanism

A single, compact and modular mechanism cassette operates two Switch-Disconnectors and provides mechanical interlocking between them.

The use of patented, self interlocked and dual dead center mechanism in CO range provides higher reliability for changeover function.

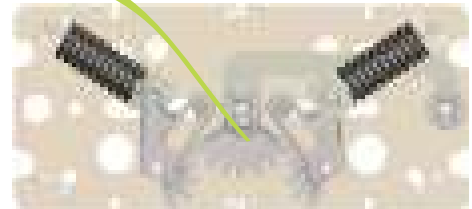

2. Terminal shroud

These shrouds provide complete touch proof design and prevent accidental touching of live terminals. They are click fit type. Due to hinge type terminal shrouds, it can be turned by 90 degree, hence terminals can be inspected without removing these shrouds.

3. Source separator

Source separator is used to isolate two incoming supplies and to eliminate possibility of flash over between two supplies due to accidental falling of external objects.

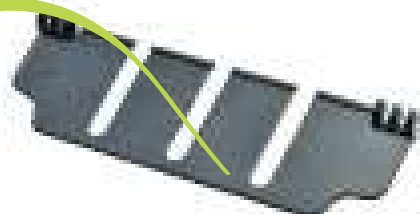

Manual Changeover Product Feature

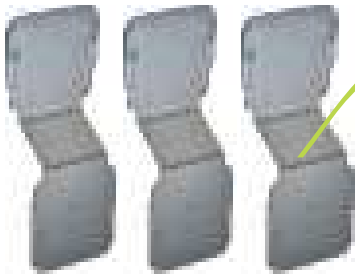

4. Inter-phase barriers

Inter-phase barriers are provided for additional safety to eliminate possibility of inter-phase short-circuit.

5. Positive ON / OFF indication of S-Ds

The Changeover S-D indicates true position of contacts.

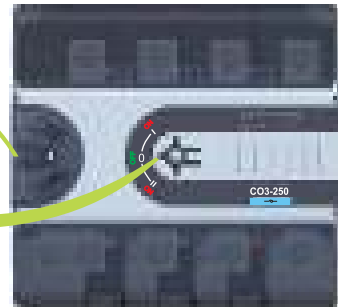

6. Staggered terminals

The Changeover S-Ds are designed to have staggered terminal arrangement for top and bottom S-Ds. It provides clear access to all terminals from the front, ensuring ease of termination.

All terminal joints can be easily inspected without the need of removing termination of top S-D.



7. Interchangeable dual shaft position with site convertibility

Patented dual dead enter mechanism enables the user to choose between central and side shaft positions for operating handle. This can be easily converted on site as required (125A to 1000A).



Manual Changeover Product Feature

8. Handle

The Changeover Switch has a unique flip-able operating handle for ratings 250 Amp and above which enables user to operate the switch with two hands. The handle also offers the following features:

- Provision for Padlocking in OFF position with three Padlocks of Ø5 to Ø7
- Defeat feature in both ON states and auto restoration of panel door
- IP54 with extended type operating handle



Two hand type flip-able handle
250 A & above rating



One hand type handle
upto 200 A rating



Changeover unit
padlockable in OFF state by 3 pad locks



9. Auxiliary contact kit

It consists of two sets changeover contacts one for each S-D. This kit is pre-wired with terminal blocks and is offered as a standard feature with open execution Manual Changeover Switches.

10. Castell lock

Accessory to lock the Changeover Switch in OFF state and using this can have interlocking schemes between multiple Switches.



Sheet steel enclosure

The Changeover Switches are available in sheet steel enclosure with adequate space for cable terminations so that additional cable entry boxes are not required.

Manual Changeover Product Feature

Changeover Switch with Direct Handle

Compact direct handle 63 A and 100 A changeover switch suitable for double door DB. It occupies only 10 Mod space (45 x 140 cut-out).

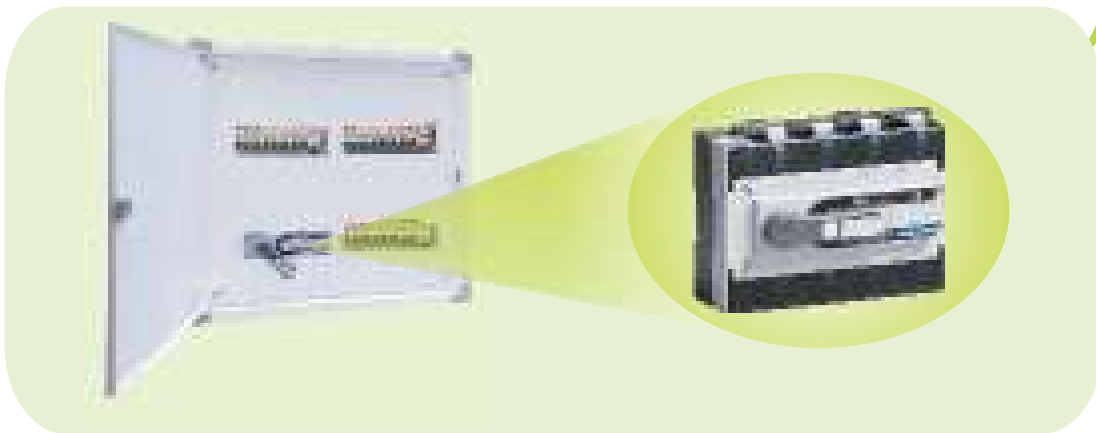

Fuse Changeover Switch

The Changeover S-Ds for open execution can be easily converted to fused version at site by using fuse conversion kit. It can be used either to protect against one supply (line) or protect the load side (no load line biasing). It provides the benefits of overload and short circuit protection through the fastest switching device-fuse, and is suitable for cylindrical & knife type (DIN) fuse links.



Technical Specifications of Manual Changeover

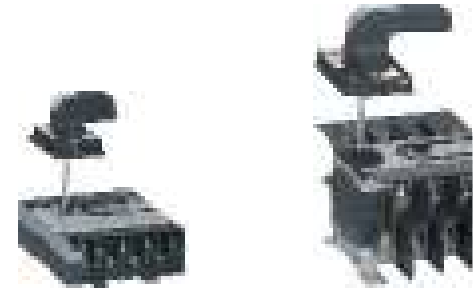

Rating (A)		Unit	Frame 1			Frame 2	
			63 A	100 A	125 A	125 A	160 A
Reference Standards							
Type designation			CO1-63	CO1-100	CO1-125	CO2-125	CO2-160
No. of Poles			4 Pole	4 Pole	4 Pole	4 Pole	4 Pole
Rated operational voltage (U _e)		(V)	415	415	415	415	415
Rated frequency		(Hz)	50 / 60	50 / 60	50 / 60	50 / 60	50 / 60
Rated insulation voltage (U _i)		(V)	1000	1000	1000	1000	1000
Rated impulse withstand voltage (U _{imp})		(kV)	8	8	8	12	12
Pollution degree			3	3	3	3	3
Conventional free air thermal current, I _{th} at 40°C		(A)	63	100	125	125	160
Conventional enclosed thermal current, I _{the} at 40°C		(A)	63	100	125	125	160
Rated operational current, I _e AC-21A [#] / AC-22A [#] / AC-23A		(A)	63	100	125	125	160
Rated operational power for AC-23A*		(kW)	37	50	65	65	85
Rated breaking capacity for AC-23A		(A)	504	800	1000	1000	1280
Rated making capacity for AC-23A		(A)	630	1000	1250	1250	1600
Short time withstand, I _{sw}	1 sec	(kA rms)	4	5	5	8	8
	0.2 sec	(kA rms)	7	10	10	18	18
Short-circuit making capacity, I _{cm}		(kA peak)	5.9	7.7	7.7	14	14
Endurance (category A)	Mechanical	(O-I-O-II-O cycle)	20000	20000	20000	16000	16000
	Electrical	(O-I-O-II-O cycle)	3000	3000	2000	2000	2000
Type and size of fuse	DIN/Cylin [▲]		14 x 51 [▲]	NA	NA	000	00
Rated fused short-circuit current at 415 V, 50/60 Hz	DIN/Cylin [▲]	(kA rms)	80 [▲]			100	100
Termination Capacity							
Maximum Al. cable with lug		(sq mm)	25	50	70	95	95
Maximum link width		(mm)	16	22	22	30	30
Maximum link thickness		(mm)	2	4.7	4.7	5	5
Termination tightening torque		(N-m)	4.5	4.5	4.5	10	10
Operating torque center / side operating		(N-m)	4.5	4.5	4.5	10 / 13	10 / 13
Weight (without accessories)		(Kg)	2	2.5	2.7	4	4

* These values are for 4 pole squirrel cage induction motors and are provided only for guidance and may vary as per the motor manufacturer

Rated operational current, I_e AC-21A / AC-22A

▲ Type cylindrical fuse

§ Claimed Impulse withstand voltage with use of source separator and inter phase barriers



	Frame 3		Frame 4		Frame 5			Frame 6		
200 A [§]	250 A	315 A	400 A	630 A	630 A	800 A	1000 A	1250 A	1600 A	2000 A

IS / IEC 60947-3, EN 60947-3

CO2-200	CO3-250	CO3-315	CO4-400	CO4-630	CO5-630	CO5-800	CO5-1000	CO6-1250	CO6-1600	CO6-2000
4 Pole	4 Pole	4 Pole	4 Pole	4 Pole	4 Pole	4 Pole	4 Pole	4 Pole	4 Pole	4 Pole
415	415	415	415	415	415	415	415	415	415	415
50 / 60	50 / 60	50 / 60	50 / 60	50 / 60	50 / 60	50 / 60	50 / 60	50 / 60	50 / 60	50 / 60
1000	1000	1000	1000	1000	1000	1000	1000	1000	1000	1000
12 ^s	12	12	12	12	12	12	12	12	12	12
3	3	3	3	3	3	3	3	3	3	3
200	250	315	400	630	630	800	1000	1250	1600	2000
200	250	315	400	630	630	800	1000	1250	1600	2000
200	250	315	400	630	630	800	1000	1250	1600 [#] /1250	2000 [#] /1250
85	132	160	225	315	315	400	450	710	710	710
1600	2000	2520	3200	5040	5040	6400	8000	10000	10000	10000
2000	2500	3150	4000	6300	6300	8000	10000	12500	12500	12500
8	16	18	22	26	35	50	50	50	50	50
18	28	28	35	35	70	85	85	85	85	85
14	32	36	46	55	73.5	105	105	105	105	105
16000	16000	16000	10000	10000	10000	10000	10000	10000	10000	10000
2000	2000	2000	2000	2000	2000	1000	1000	1000	1000	500
NA	1	1	2	NA	3	3	NA	NA	NA	NA
	100	100	100		100	100				
150	185	240	2 x 300	2 x 300	2 x 400	2 x 400	2 x 400	2 x 12 x 63	4 x 8 x 50	3 x 10 x 100
30	40	40	50	50	60	60	60	80	80	100
5	8	8	8	2 x 8	2 x 10	2 x 10	2 x 10	3 x 12	3 x 12	3 x 12
10	20	20	27	27	35	35	35	55	55	55
10 / 13	20 / 25	20 / 25	28 / 32	28 / 32	30 / 40	30 / 40	30 / 40	55	55	55
4	6.5	7	14	14.5	20	22	22	52	57	75

Motorised Changeover Product Features

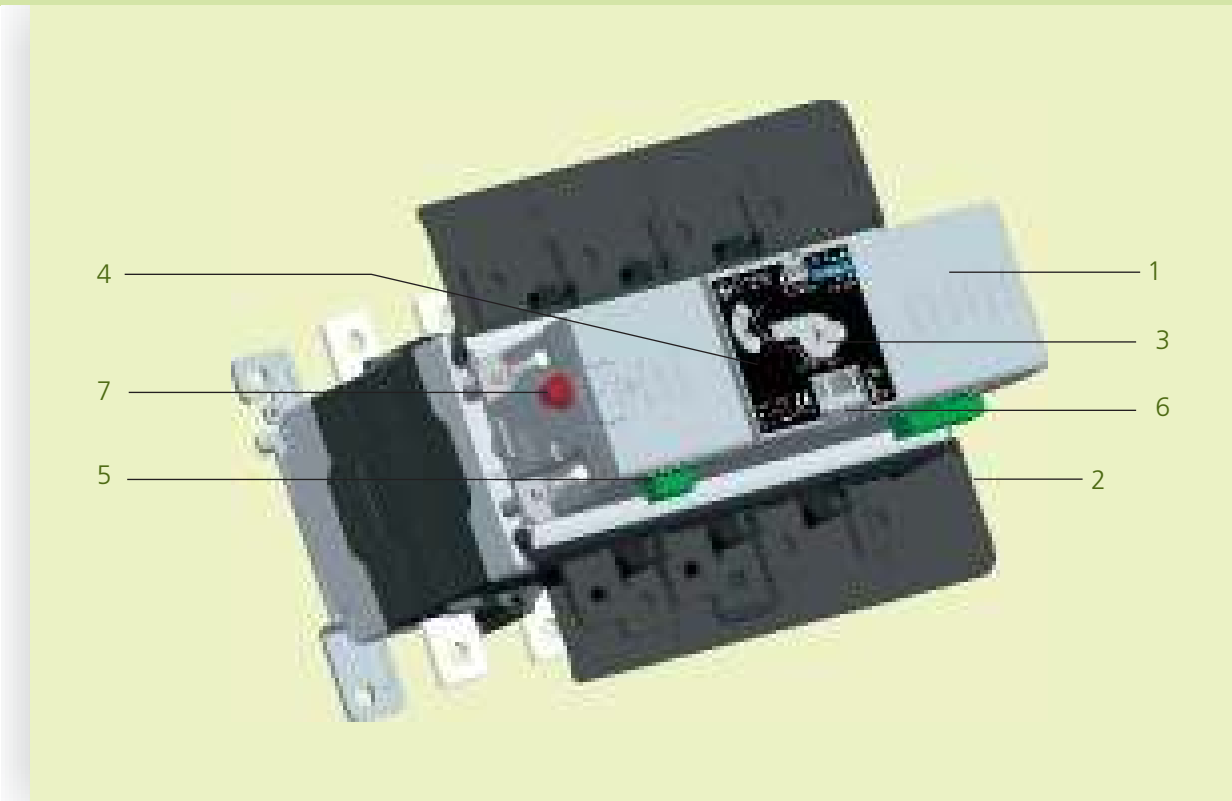

1. Compact design

No change in H x W x D of motorised changeover switch and manual changeover switch.

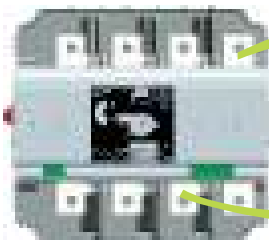
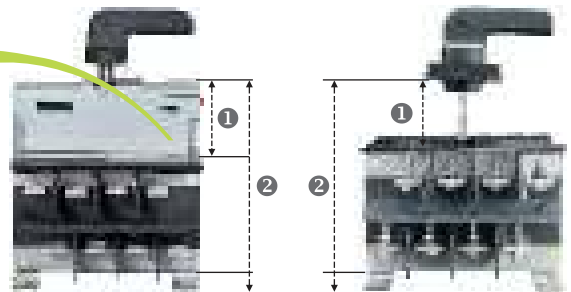

2. Clear termination access

Motorised kit (EOM) fits well within the body of the manual changeover switch, enabling clear access to the terminals even after mounting the motorised kit.

3. Manual override

Manual operation of motorised changeover switch is also feasible through the manual override feature.

As a safety feature, the control supply of motorised kit (EOM) is automatically cut off during the insertion of handle.



Motorised Changeover Product Features

4. Manual and Auto mode selection

The selector switch enables/disables the control supply to motorised changeover switch. Electrical operation is possible only in auto mode while manual mode allows the user to operate the motorised changeover switch manually by using the handle safely. As a safety feature the control supply of motorised changeover is automatically cut off during the insertion of handle.

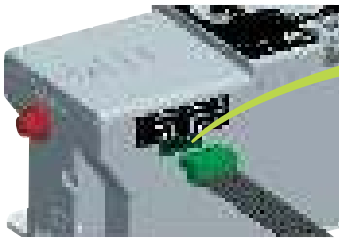
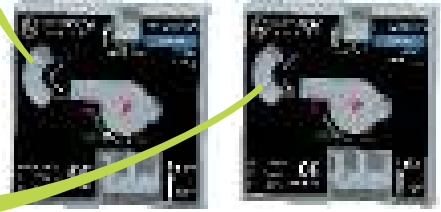

5. Auxiliary contacts

It consists of two sets of changeover contacts one for each S-D. It is prewired and prefitted in motorised changeover switch.

6. Pad locking

Provision for padlocking in OFF position with three padlocks of Ø5 to Ø7. Padlocking is possible in both auto and manual mode.

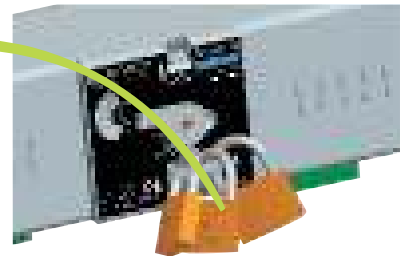











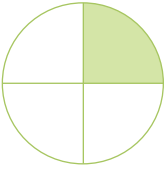

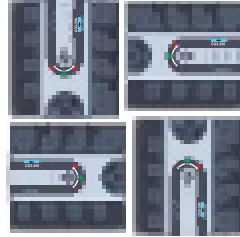

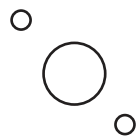
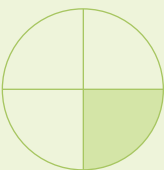

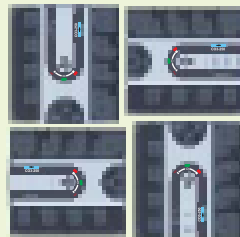
7. Fuse protection

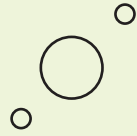
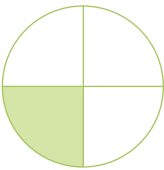
Inbuilt glass fuse of 5 x 20 size protects the motorised kit (EOM) during abnormalities. Also, spare fuse holder has been provided for storage of fuse.

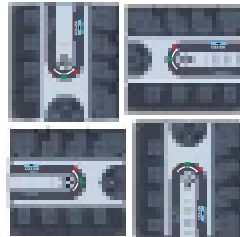
Universal Mounting for Manual Changeover Range

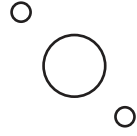
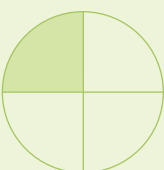
The manual changeover range also offers a distinctive feature to mount CO SD in different quadrants. This feature aids mounting flexibility.

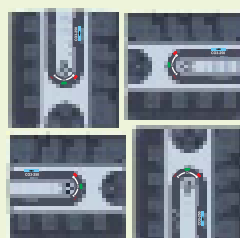
Operating Quadrant chart (Seen from front of the door)

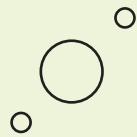
Sr. No.	Operating Quadrant	Handle (OFF) Position	Switch Orientation	Shaft Position	Door Cut-out
1					
2					
3					
4					

Automatic Source Transfer System



Illuminated Push button assembly with Wire harness



- UV/OV based AST Controller with Wire Harness**
- Option of controlling Motorised Changeover through Illuminated push button or UV/OV relay
 - Sensing of three-phase voltage controls
 - Protects against under voltage and over voltage
 - Option of programming of minimum voltage, maximum voltage and time delay

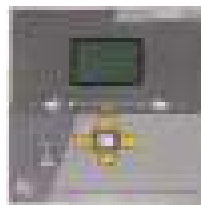

AuxG-2000 Controller with Wire Harness

- Option of sensing : Three-phase, two-phase or single-phase voltage controls
- Option of Measuring : Phase-phase voltage and/or phase-neutral voltage control
- Protects against under voltage, over voltage, phase loss, asymmetry, under frequency, over frequency, with independent enable and delay voltage thresholds with programmable hysteresis
- 6 programmable digital inputs & relay outputs (5NO + 1 C/O)

ASTS with AST Controller

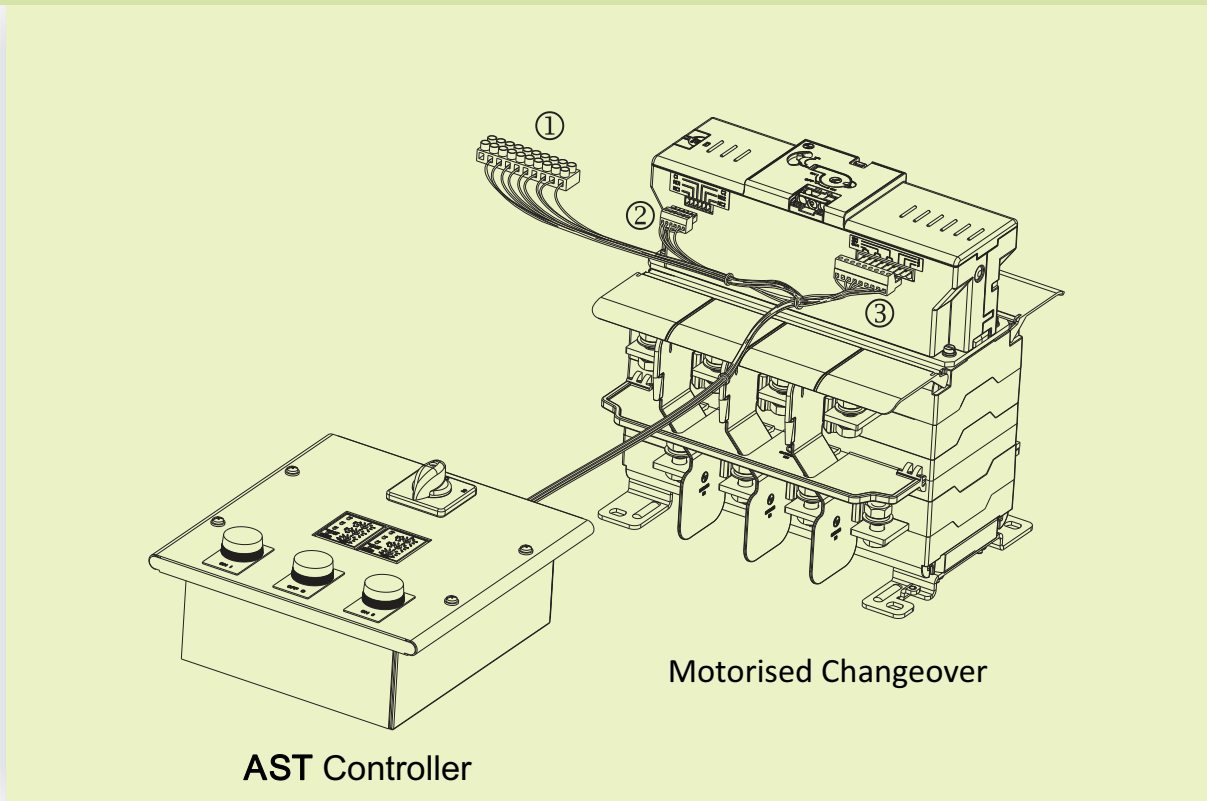

AST Controller

Motorised Changeover

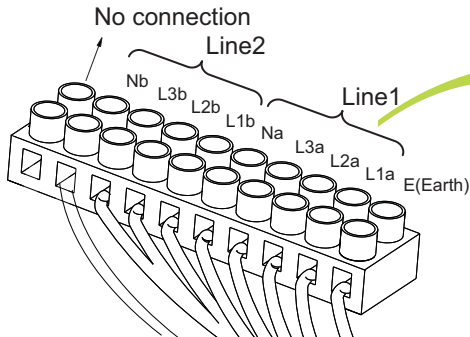

1. Control supply terminal block

Source I & II sensing inputs are to be connected for continuous monitoring by AST controller.

2. Auxiliary contact Set connection

Two sets of pre-wired changeover auxiliary contacts one for each S-D. Same is used for power contact position feedback & status indication

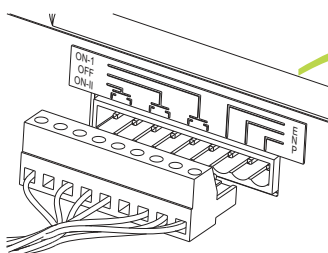
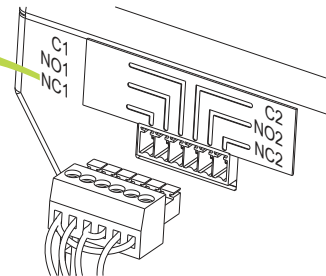

3. Main terminal connection

Control inputs to motorised changeover through AST controller

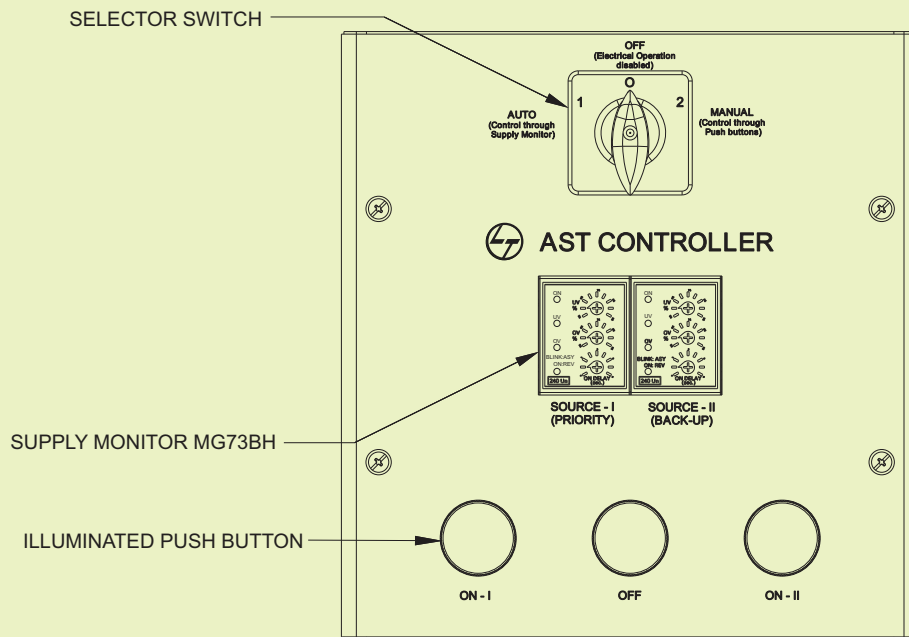

Auto Mode

In auto mode Source-I (priority source) is continuously monitored, in case of Source-I failure AST controller checks for Source-II (back-up source). If it is available then AST controller gives command to motorised changeover to shift on Source-II.

On restoration of Source-I (priority source) motorised changeover moves back to it.

Illumination in the push buttons will be functional indication of the the motorised changeover switch position.

Option of setting over voltage : Recommended setting 110% of the supply voltage

Option of setting under voltage : Recommended setting 85% of the supply voltage

Option of setting time delay : 0 -15 seconds

Manual Mode (Electrical)

Control of motorised changeover switch using illuminated push buttons.

Manual Mode (Operating handle)

Manual control using operating handle, as a safety feature the control supply of motorised changeover is automatically cut off during the insertion of handle.

ASTS with AuXC 2000 Controller

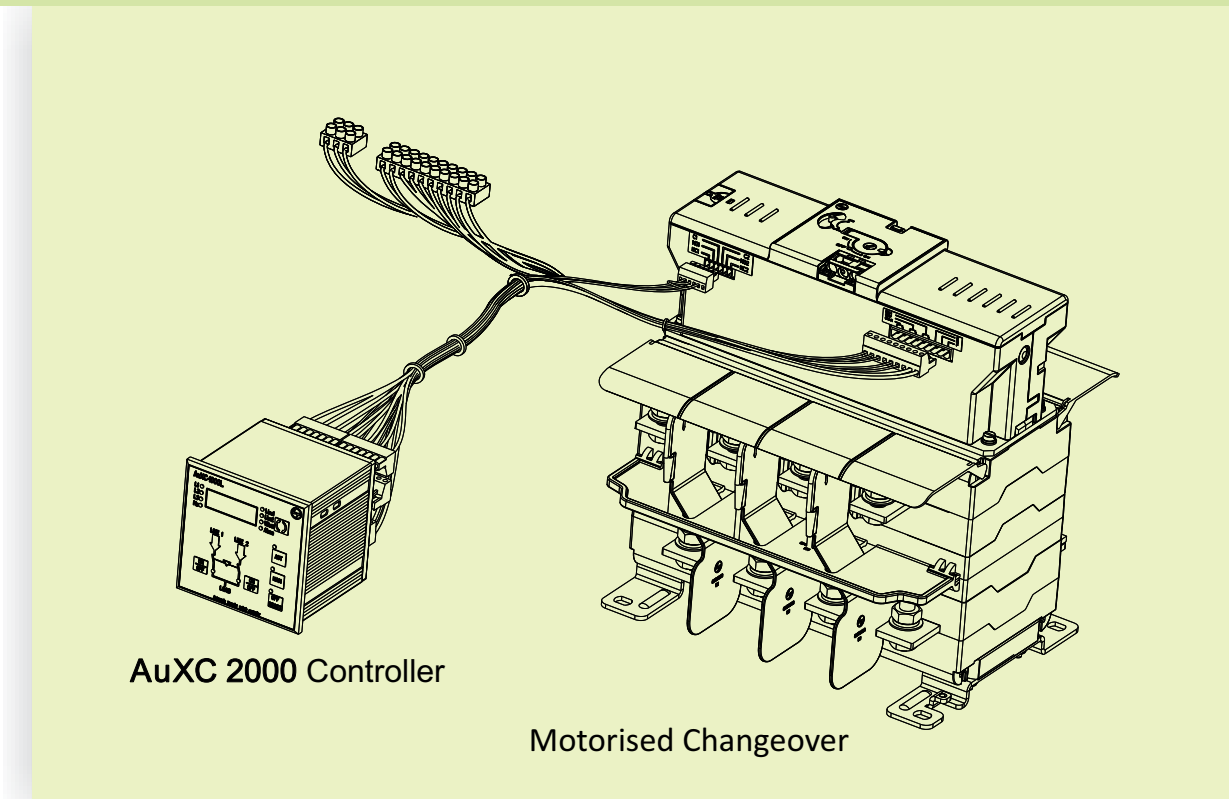

Modes of Operation:

OFF Mode:

In this mode, the automatic control is disabled and the controller does not take any action. All views of the measures and the status of the LEDs remain active.

To access the programming/settings menu, it is mandatory to operate in OFF mode.

Pressing the OFF-RESET button resets the retentive alarms, provided the conditions that generated the alarm have been removed.

Manual Mode:

In this mode, the MCO can be manually controlled by the pressing the MAN key.

Closing/opening operation can be achieved by :

- Selecting the switch position
- Pressing the ▲ and ▼ buttons, for a minimum time of 300ms, to confirm the closing or opening operation

The generators can also be controlled manually by moving on the page start/stop groups.

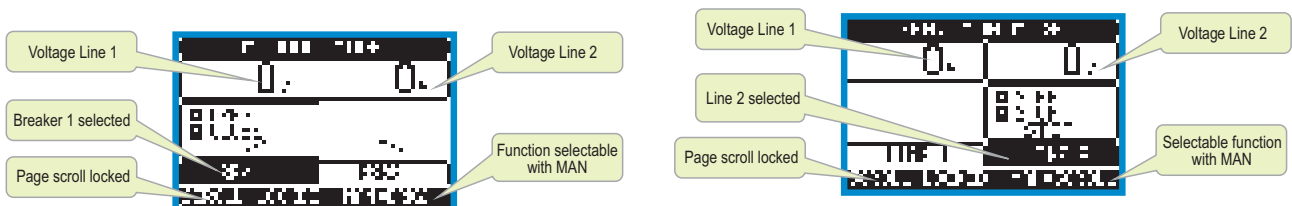

AuxC-2000 Controller

Front buttons functions

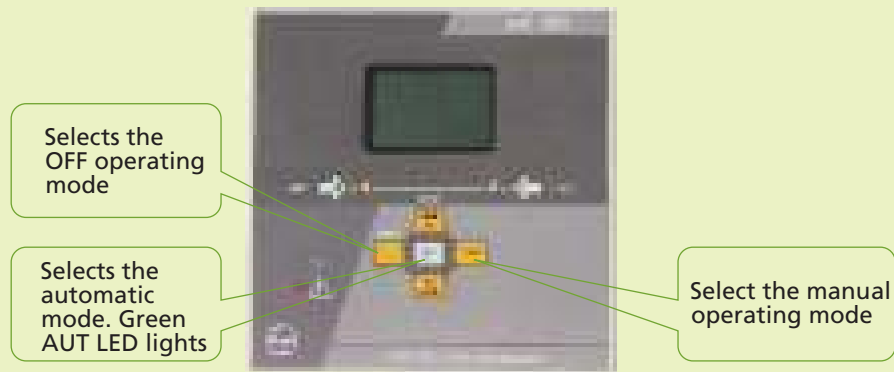

▲ and ▼ keys - Used to scroll through the display pages or to select the list of options in a menu. Simultaneously pressing ▼ + calls up the Main menu with rotating icons

Front LED

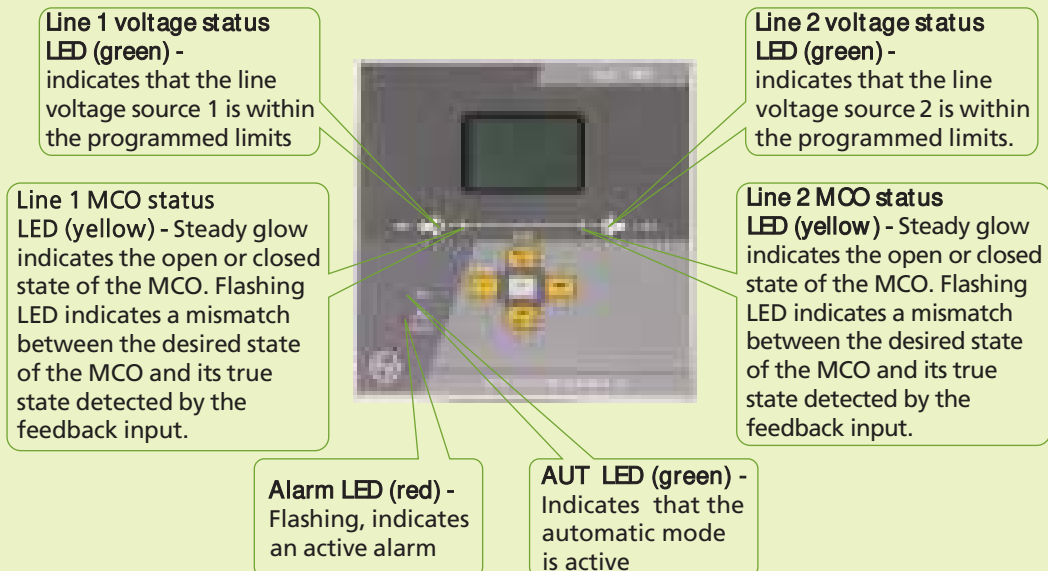

Auto Mode:

The AUT mode is indicated by the green LED for AUT. In automatic mode, the controller automatically gives command for opening & closing of the MCO. When the priority line voltage is out of bounds for a time longer than that specified (line presence green LED turns off), the unit disconnects the load from the priority line and connects it to secondary line considering start-up of generator (if programmed) and interlock time delay. When the priority line returns within the programmed limits, the controller will switch back the load on it.

The cycles of automatic operation vary according to the type of application (utility-utility, utility-generator, generator-generator).

Other Benefits & Features in Auto Mode

- Protection against UV, OV, phase loss, asymmetry, under frequency and over frequency
- 6 programmable digital inputs & relay outputs (5NO + 1C/O)
- Measuring and sensing of system variables
- DG set start/stop control
- Priority source swap

Technical Specifications of Motorised Kit



			Frame 2
Rating (A)		Unit	125 to 200
Reference Standards			
Rated frequency		(Hz)	50
Rated control voltage		(V)	240 V ac
Control voltage range		(%)	85% - 110%
Pollution degree			3
Operating temperature		(°C)	-5 to + 55
Ingress protection (from front)			IP30
Max. current at 240 V ac		(A)	2
Operating time (min)	O-I / I-O	(sec)	0.5
	I-II / II-I	(sec)	1.4
Black out time		(sec)	1.4
Control glass fuse current rating	(240 V ac)	(A)	1.25
Dimensions of motorised kit	Width	(mm)	210
	Height	(mm)	84
	Depth	(mm)	94



Frame 3	Frame 4	Frame 5	Frame 6
250 & 315	400 & 630	630 to 1000	1250 to 2000
IS/IEC 60947-3, IEC 60947- 3, EN60947-3			
50	50	50	50
240 V ac	240 V ac	240 V ac	240 V ac
85% - 110%	85% - 110%	85% - 110%	85% - 110%
3	3	3	3
-5 to + 55	-5 to + 55	-5 to + 55	-5 to + 55
IP30	IP30	IP30	IP30
2	2	2	2
0.6	0.7	0.7	0.7
1.4	1.4	1.4	1.4
1.4	1.4	1.4	1.4
2	2	2	2
260	310	380	274
84	84	84	108
94	94	94	118

Enclosed Automatic Transfer Switch

Rapid industrialization and urbanization are leading to ever-rising demand for reliable electricity.

Technological advancement and changing lifestyles have given rise to many applications which demand 24 X7 uninterruptible power supply. In some industries, power outages for even short duration may lead to considerable commercial losses.

E&A's Enclosed Automatic Transfer Switch(ATS) constantly monitors the incoming power sources and seamlessly switches the load to the 'back-up' supply when it senses variation or abnormality in the main supply. Once main supply is restored, the load is automatically shifted to the main supply.

Option of priority source selection and swapping gives additional flexibility to suit different site requirements.

These switches are very convenient to use as one does not have to manually operate the switch.

The typical applications are in critical processes in various industries and also in growing residential, commercial & infrastructure segments.

Enclosed Automatic Transfer Switch(ATS):

E&A's C-Line Motorised Changeover switch alongwith AuxC 2000 controller is completely pre-programmed and pre-wired Automatic Source Transfer Solution.

What's more is that the complete ensemble is mounted in a smart engineered SS enclosure providing a ready, convenient -to-use solution.

Automatic Solution | Pre-wired | Flexible Settings

Enclosed Automatic Transfer Switch

Range:
125A to 630A,
415V AC



Flexibility

- Priority Source Selection
- Adjustable Time Delay (0.1 sec to 3 hours)
- Suitable for 3-Phase as well as 1-Phase Sources



Performance

- Double-Break Contact System offering High Short-time withstand (I_{cw})
- High Mechanical & Electrical Life: Double than requirement of IS/IEC Standard
- Suitable for Aluminium Termination



Safety

- Protections : UV/OV, Phase Sequence, Single Phasing, Frequency
- Authorized Access Control through Password Protection
- Inbuilt Terminal Shrouds, Phase Barriers & Source Separator



Convenience

- Ample Space for Cable Termination, No need of Separate Cable Gland Box
- Ease of Generator Control (ON-OFF Cooling Cycle, Self-Test)
- Cyclic Event Logger : Logs 100 Events

Enclosed Automatic Transfer Switch

Pre-programmed Parameters

Programming	Connection Terminal	Code	Setting (Description)
Inputs	15(INP1)	M10>> P10.01.01	Line 1 closed (Feedback 1)
	16(INP2)	M10>> P10.02.01	Line 2 closed (Feedback 2)
Outputs	25(OUT4)	M11>> P11.04.01	Close line 1
	27(OUT5)	M11>> P11.05.01	Open line 1 / line 2
	30(OUT7)	M11>> P11.07.01	Close line 2
Others	-	M05>> P05.07	Changeover Pulse

Time Delay Setting

Parameter	Code	Default Setting	Comments
Line 1 to Line 2 interlock time	M05>>P05.03	0.1	0.1....1800Sec
Line 2 to Line 1 interlock time	M05>>P05.04	0.1	0.1....1800Sec
Presence delay (When Line 2 source not available)	M06>>P06.07	1	1....6000Sec
Presence delay (When Line 2 source available)	M06>>P06.08	1	1....6000Sec
Presence delay (When Line 1 source not available)	M07>>P07.07	1	1....6000Sec
Presence delay (When Line 2 source available)	M07>>P07.08	1	1....6000Sec

Protection Parameter Setting

Parameter	Code	Default Setting
Phase Sequence Control	M02>>P02.05	OFF
Undervoltage setting for Line 1	M06>>P06.01	85%
Overvoltage setting for Line 1	M06>>P06.04	110%
Undervoltage setting for Line 2	M07>>P07.01	85%
Overvoltage setting for Line 2	M07>>P07.04	110%

General Control Setting

Parameter	Code	Default Setting	Comments
Select Nominal Voltage	M02>>P02.01	400	50-5000 V AC
Select Voltage Control Mode	M02>>P02.07	L-L	L-L L-N L-L+L-N
Select Priority Line	M05>>P05.02	-1-	-1- Line 1 -2- Line 2

Generator Start/Stop Control

Parameter	Code	Default Setting	Comments
Digital Output 3 (Terminal No. 22 & 23)	M11>> P11.03.01	Start/Stop remote control of line 2 generator	Hardwire to general controller for ON/OFF Control
Digital Input 6 (Terminal No. 20 & 21)	M10>> P10.06.01	Generator ready 2	Hardwire for generator status feedback

Note : Refer AuXC2000- Automatic Transfer Controller Manual for further details and complete settings/programming parameters

Ordering Information



Inclusive of cable gland box

Frame	Rating (A)	Manual open execution version	Manual SS enclosure version	Fuse mountable kit	Motorised Open Execution Version	Enclosed ATS
Control Voltage		-	-	-	240 V ac	240 V ac
I	63 A	CO106300000	CO106300S00	CX106300O00	-	-
		CO106300O0D*				
	100 A	CO110000000	CO110000S00	-	-	
CO110000O0D*						
	125 A	CO112500000	CO112500S00	-	-	
II	125 A	CO212500000	CO212500S00	CX212500O00	CK90161B000	CK90161B500
	160 A	CO216000000	CO216000S00	CX216000O00	CK90162B000	CK90162B500
	200 A	CO220000000A	CO220000S00	-	CK90163B000	CK90163B500
III	250 A	CO325000000	CO325000S00	CX325000O00	CK90164B000	CK90164B500
	315 A	CO331500000	CO331500S00	CX331500O00	CK90165B000	CK90165B500
IV	400 A	CO440000000	CO440000S00	CX440000O00	CK90166B000	CK90166B500
	630 A	CO463000000	CO463000S00	-	CK90167B000	CK90167B500
V	630 A	CO563000000	-	CX563000O00	CK90168B000	-
	800 A	CO580000000	CO580000S00	CX580000O00	CK90169B000	
	1000 A	CO510000000	CO510000S00	-	CK90170B000	
VI	1250 A	CO612500000 ♦	-	-	CK90081B000	-
	1600 A	CO616000000 ♦	-	-	CK90082B000	
	2000 A	CO620000000 ♦	-	-	CK90083B000	

* Direct Handle Version ♦ Center operation Version



Frame	Rating (A)	Auxiliary contact for manual version (2 sets of changeover contact)	Operating handle suitable for		Operating push button assembly with Wire harness 240 V ac	UV/OV based AST Controller with Wire harness 240 V ac	AuXC2000 controller with Wire harness
			Manual version	Motorised version			
I	63 A, 100 A, 125 A	CX100020000	CX100010000	-	-	-	-
II	125 A, 160 A, 200 A	CX200020000	CX300010000	CK903740000	CK901950000	CK901920000	AuXC2000 Controller ATC20000000
III	250 A, 315 A	CX300020000	CK903920000#				
IV	400 A, 630 A	CX400020000	CX400010000	CK903780000			
V	800 A, 1000 A	CX500020000	CX500010000	CK906450000	-	-	Wire Harness CK900990000
VI	1250 A, 1600 A, 2000 A	CX600020000	CX600010000				

Output shorting link CO1-(63-100A) Top Side	CX10005000T
Output shorting link CO1-(63-100A) Bottom Side	CX10005000B

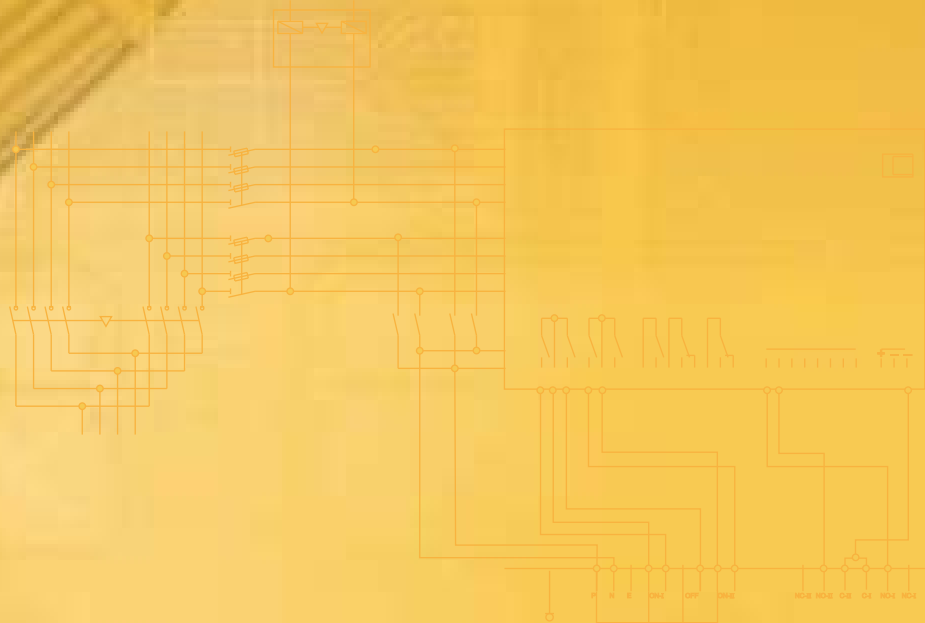

Wiring Diagrams

- Motorised Changeover Switch 28
- Motorised Changeover Switch Control
through Supply Monitor - MG73BH 28
- Motorised Changeover Switch Control
through AuXC-2000 29

Wiring Diagrams

Motorised Changeover Switch

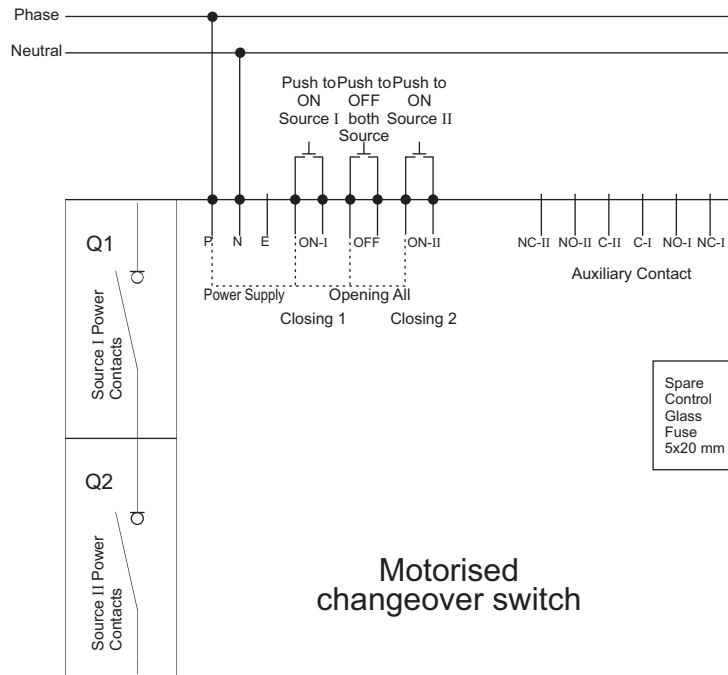

⚠ Do not push source I and source II push button together

Control of Motorised Changeover Switch through Supply Monitor - MG73BH

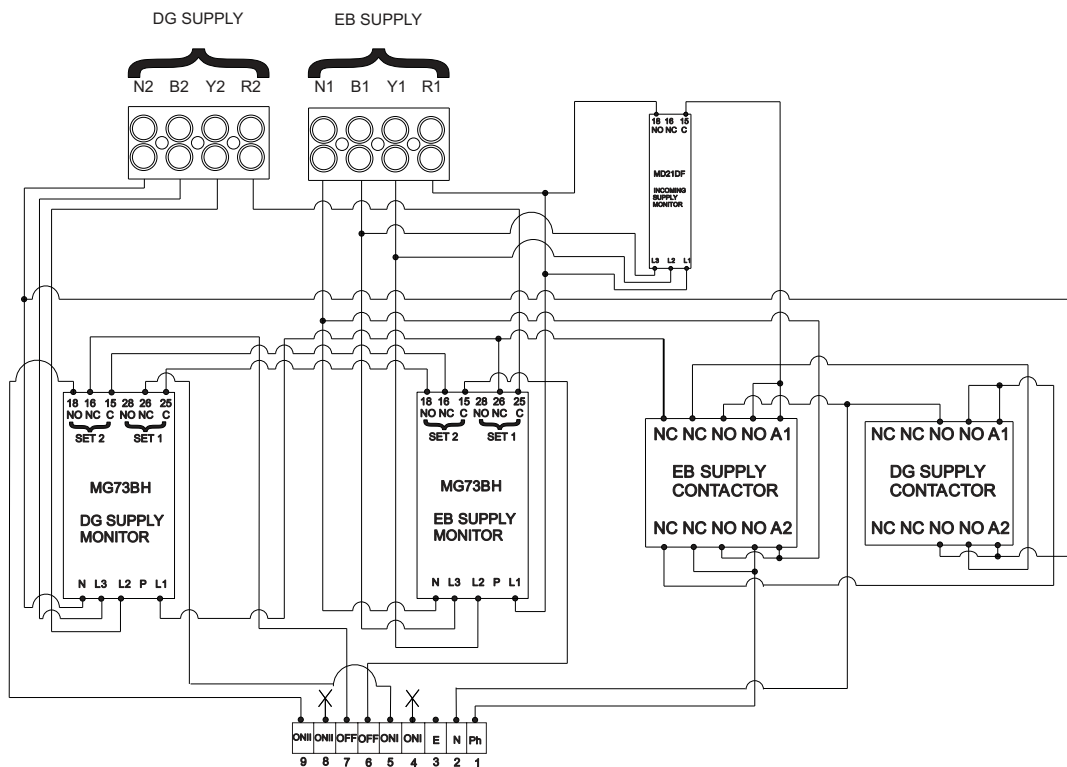

Wiring Diagrams

Control of Motorised Changeover Switch Disconnecter AuXC-2000

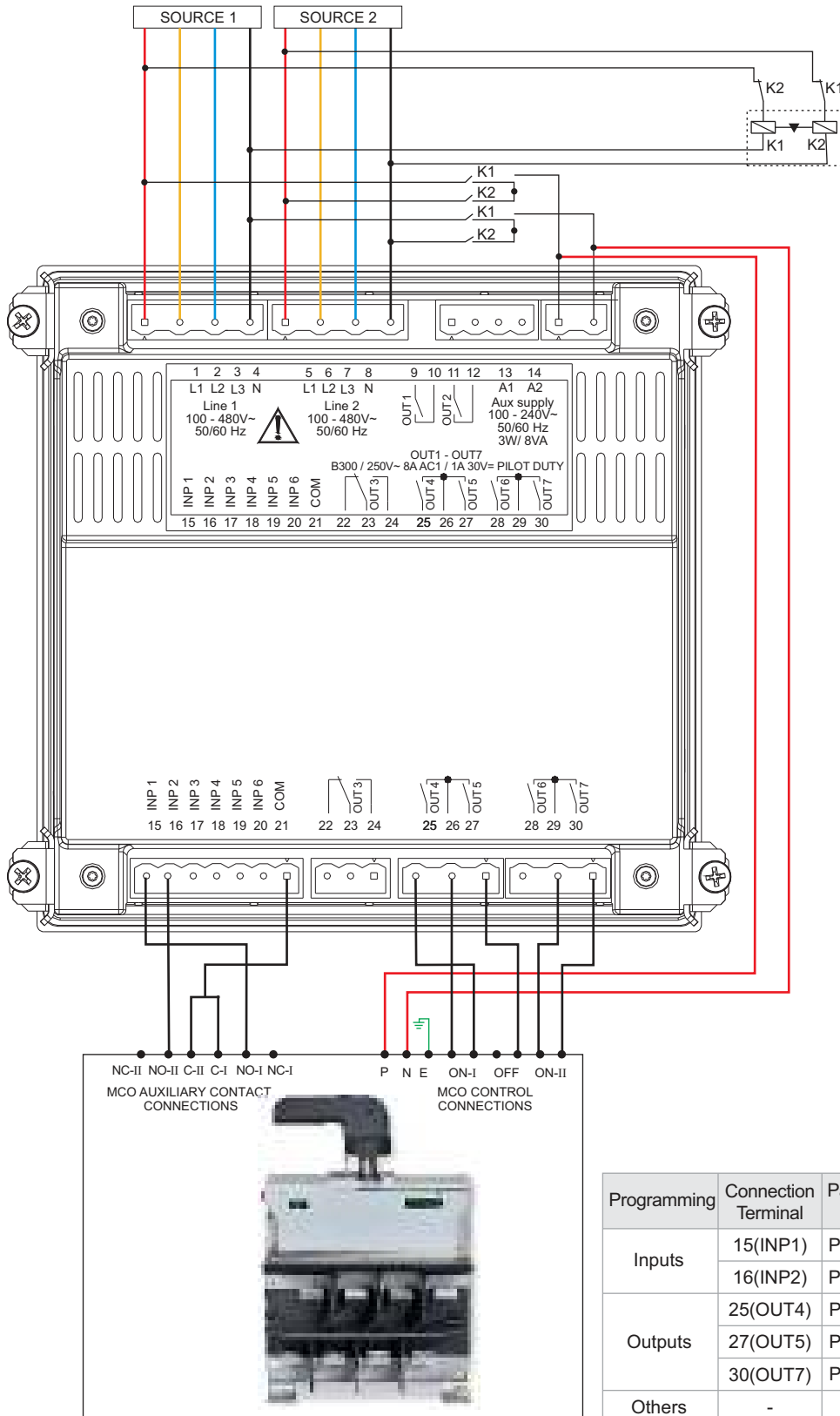

Characteristic Curves

■ HRC Fuse-link Details	31
■ Time-Current Characteristics of Type HF Fuse-links	32
■ Cut-off Current Characteristics of Type HF Fuse-links	32
■ Time-Current Characteristics of Type HN Fuse-links	33
■ Cut-off Current Characteristics of Type HN Fuse-links	33

HRC Fuse-link Details

Features

- Conform to IEC 60269-2, IS 13703 part 2
- Range: 2 A to 800 A, 415 V, AC 50 Hz
- Type: HF Cylindrical (2 A to 63 A) & HN DIN (63 A to 800 A)
- High breaking capacity: 80 kA for type HF and 100 kA for type HN



Frame	Rating (A)	Fuse mountable kit	Suitable fuse-link type	Fuse-link Size
I	63	CO Frame 1 63 A	HF	14 x 51 Cylindrical
II	125	CO Frame 2 125 A	HN	Size 000
	160	CO Frame 2 160 A		Size 00
III	250	CO Frame 3 250 A		Size 1
	315	CO Frame 3 315 A		Size 1
IV	400	CO Frame 4 400 A		Size 2
V	630	CO Frame 5 630 A		Size 3
	800	CO Frame 5 800 A		Size 3

Characteristic Curves

HRC Fuse-link Type HF Time-Current Characteristics

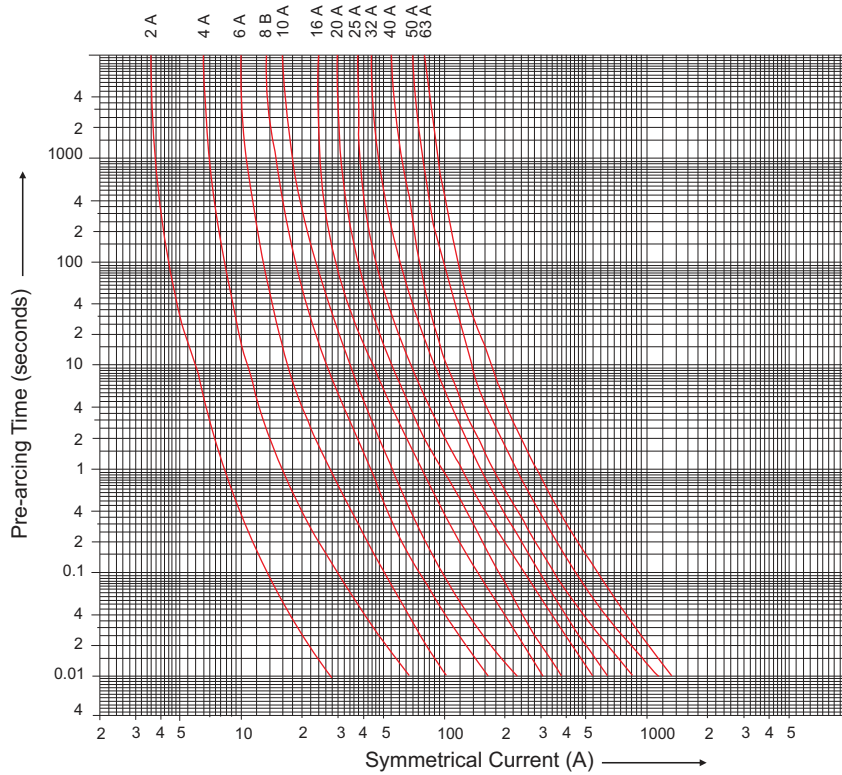

Cut-off Current Characteristics

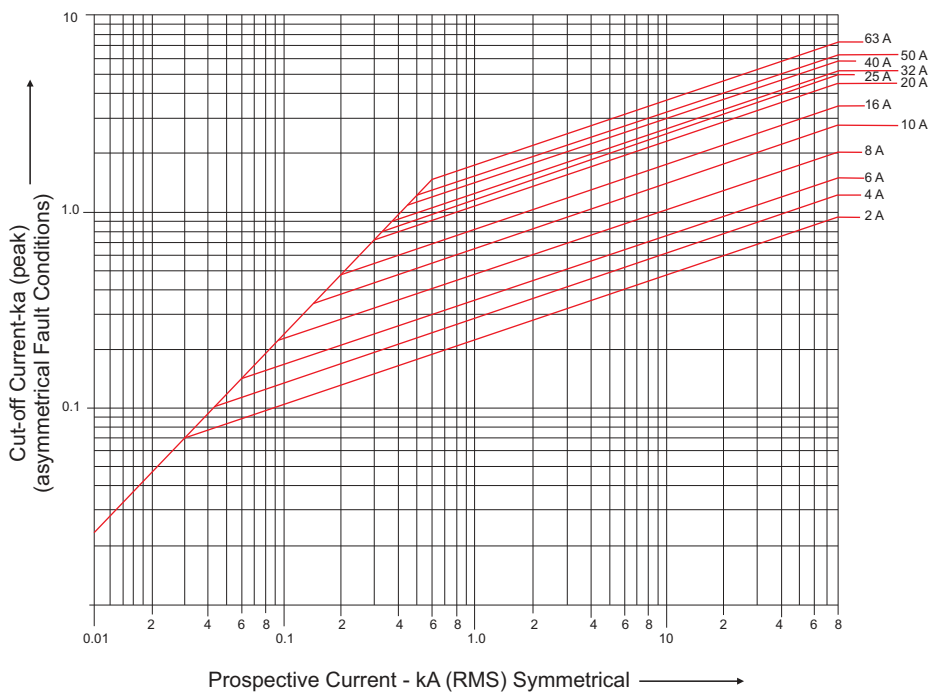

Characteristic Curves

HRC Fuse-link Type HN Time-Current Characteristics

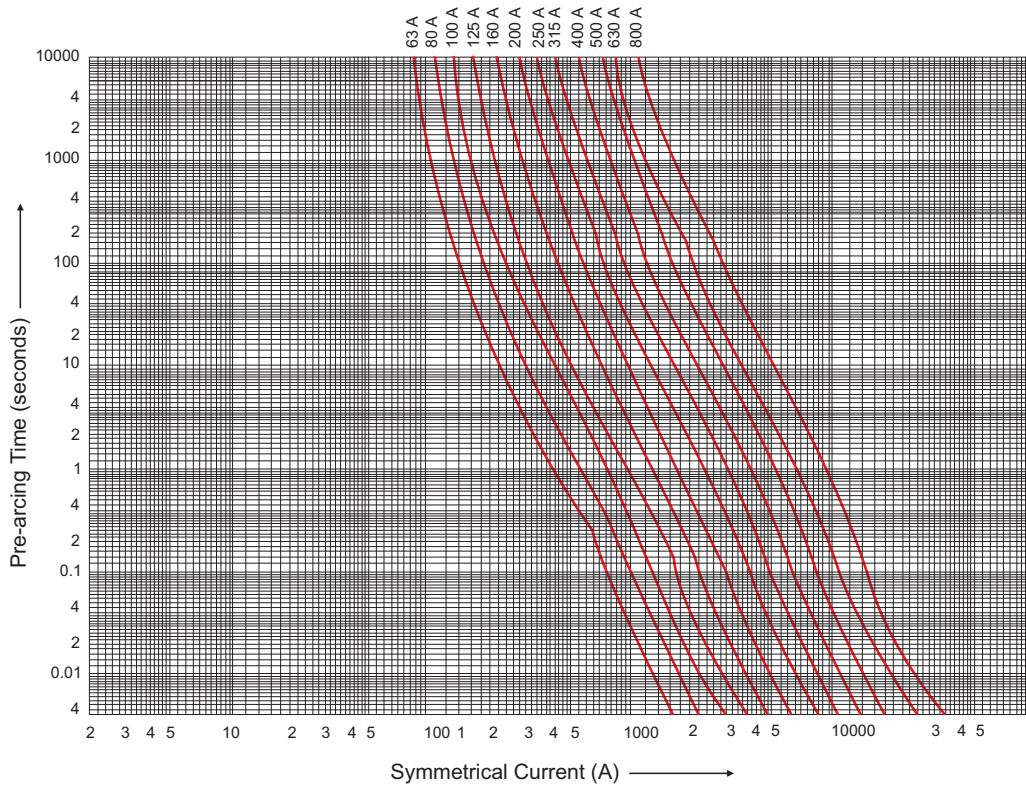

Cut-off Current Characteristics

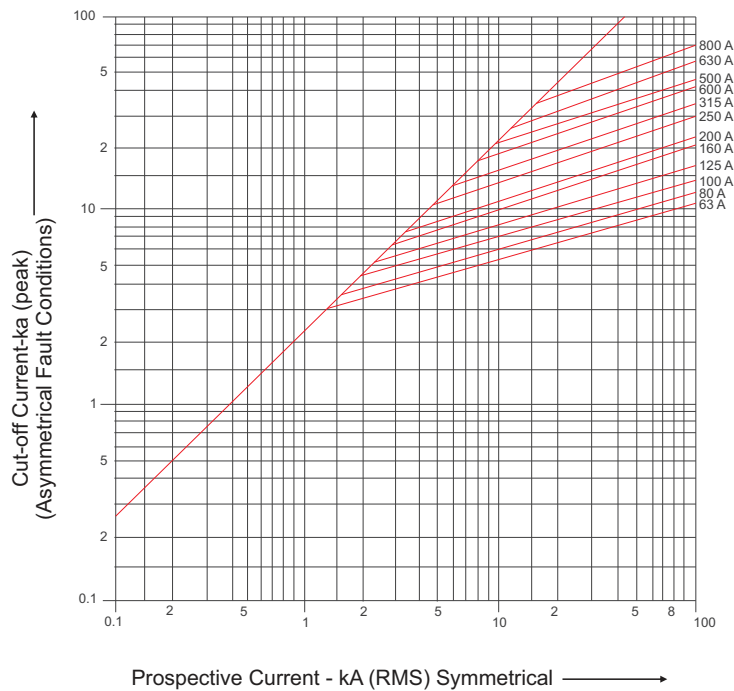



Dimensions

- Dimensions of Open Execution Manual
Changeover Switch 35
- Dimensions of Manual Changeover
Switch in Sheet Steel Enclosure 41
- Dimensions of Manual Fuse
Changeover Switch 44
- Dimensions of Motorised
Changeover Switch 47
- Dimensions of Auto Source Transfer Switch
Controller : AuXC-2000 49

Dimensions

CO1-63/100

Open Execution with Direct Handle Manual Changeover Switch

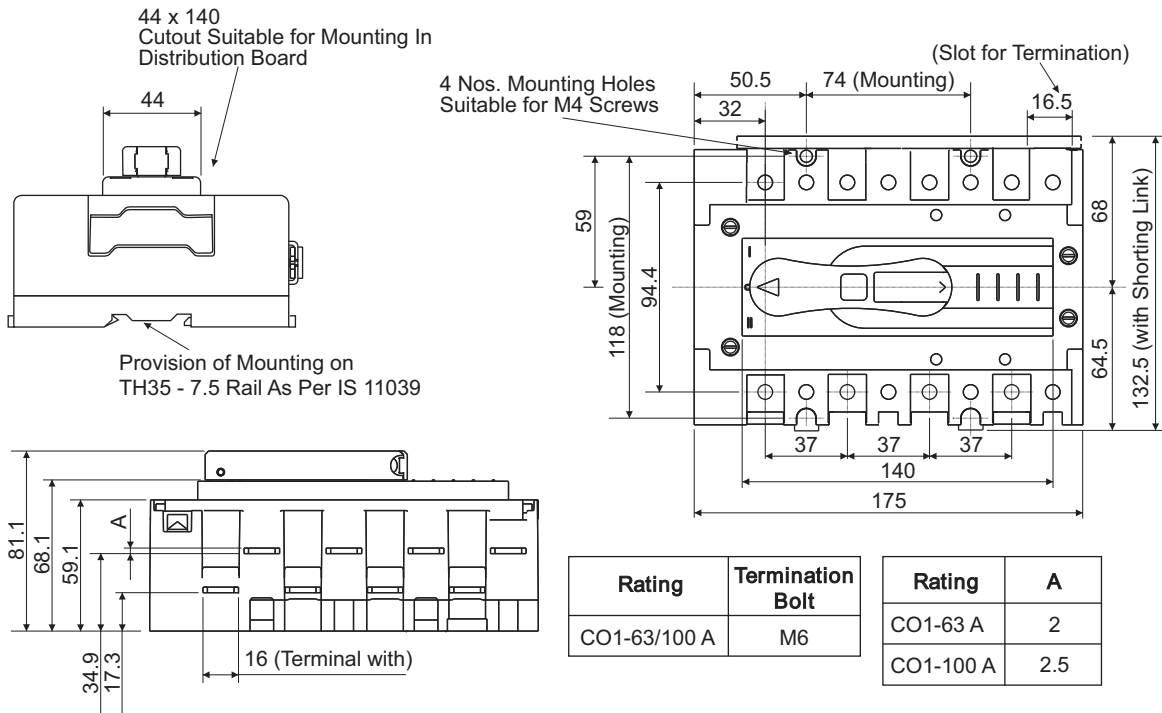

CO1-63/100/125

Open Execution with Extended Handle Manual Changeover Switch

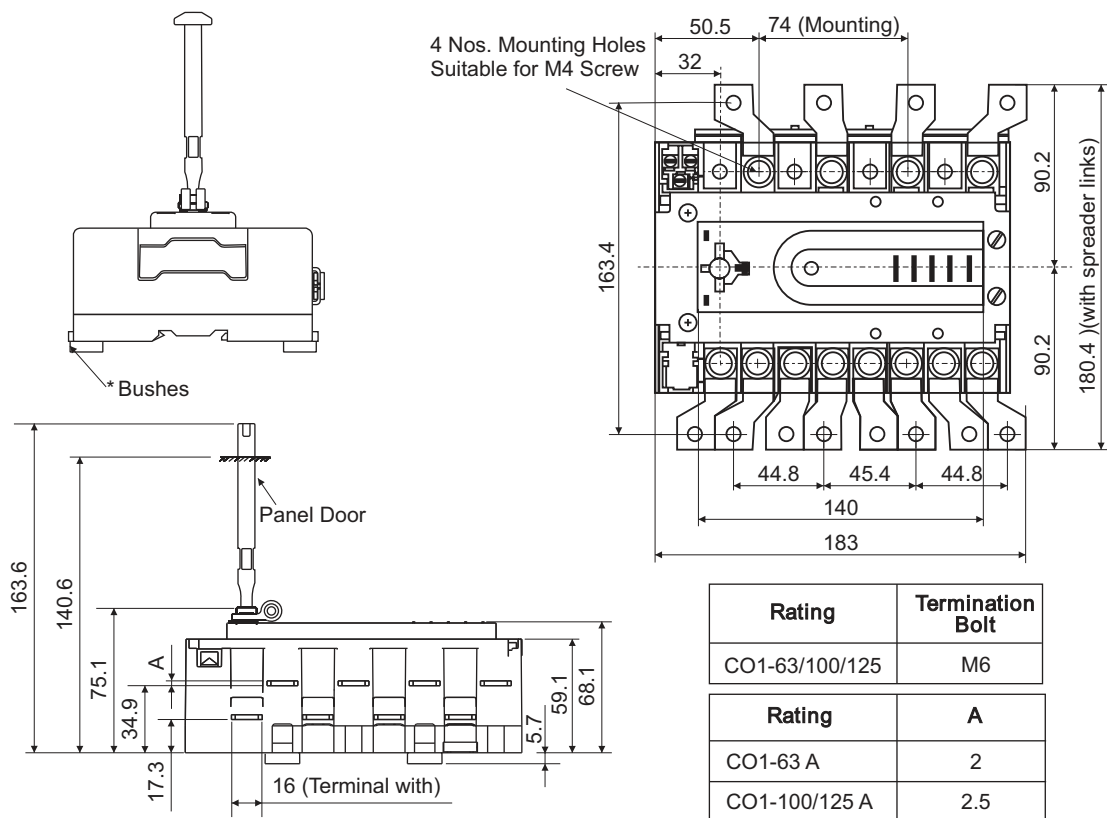

All dimensions are in mm

* Assemble bushes for higher ground clearance.

Dimensions

CO2-125/160/200

Open Execution with Extended Handle Manual Changeover Switch

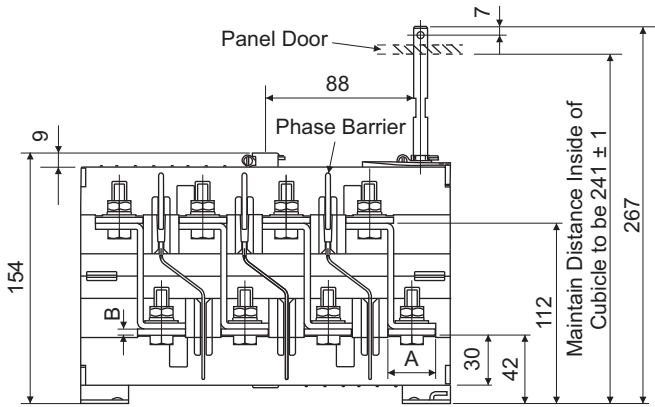

Rating	A	B	C	D
CO2-125	22	3	138	121
CO2-160	22	3	138	121
CO2-200	22	3	138	121

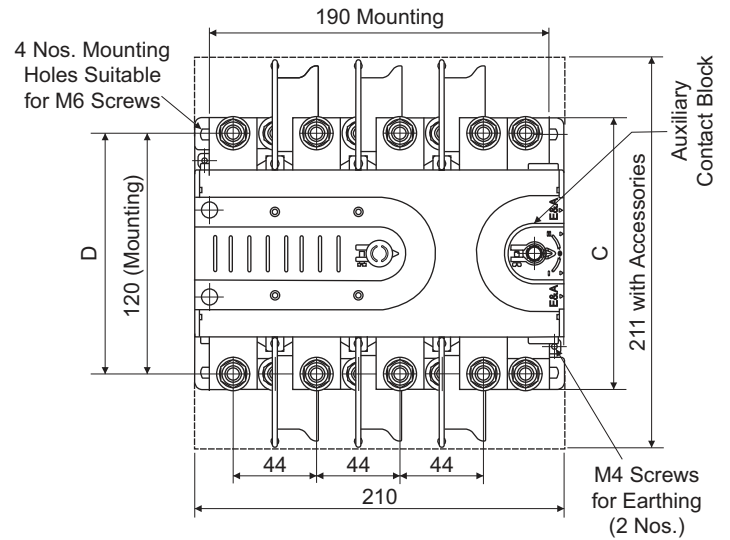

CO3-250/315

Open Execution with Extended Handle Manual Changeover Switch

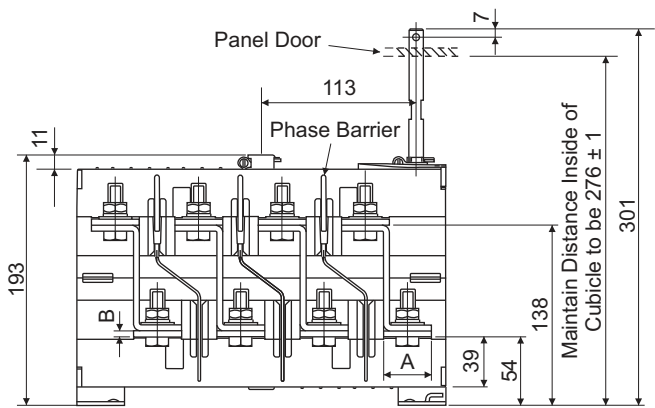

Rating	A	B	C	D
CO3-250	29	4.5	182	156
CO3-315	35	5	198	164

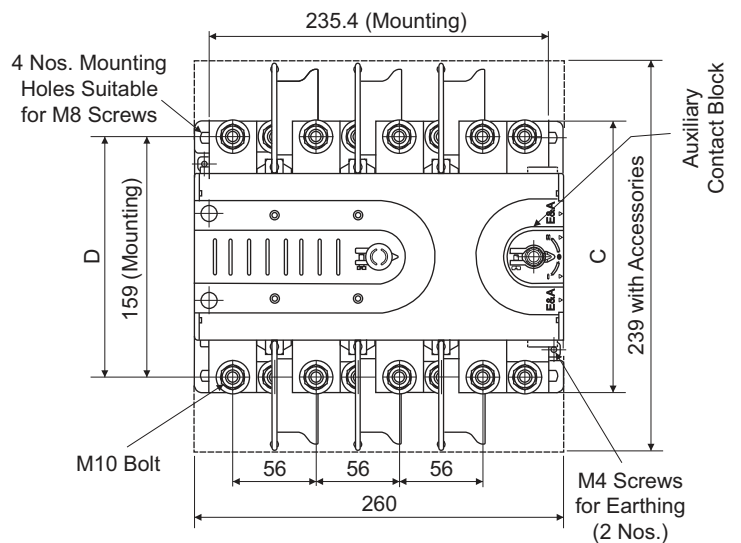

All dimensions are in mm

Dimensions

CO4-400/630

Open Execution with Extended Handle Manual Changeover Switch

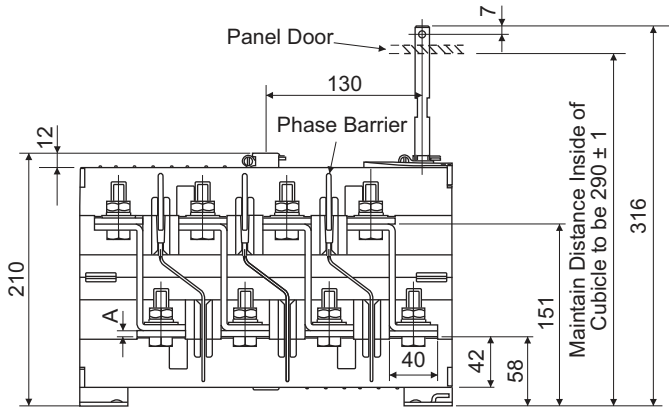

Rating	A
CO4-400	5
CO4-630	6

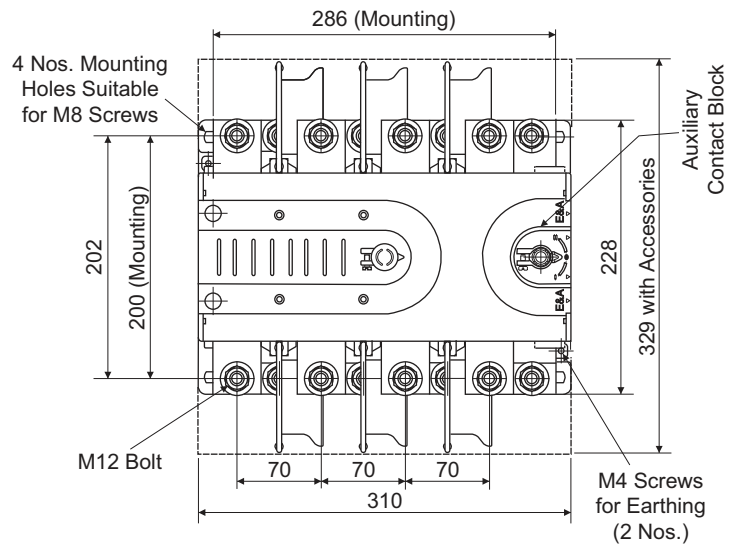

CO5-630/800/1000

Open Execution with Extended Handle Manual Changeover Switch

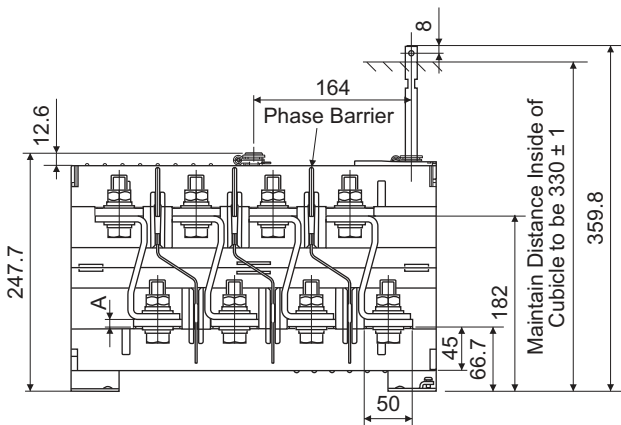

Rating	A
CO5-630	6
CO5-800	8
CO5-1000	8

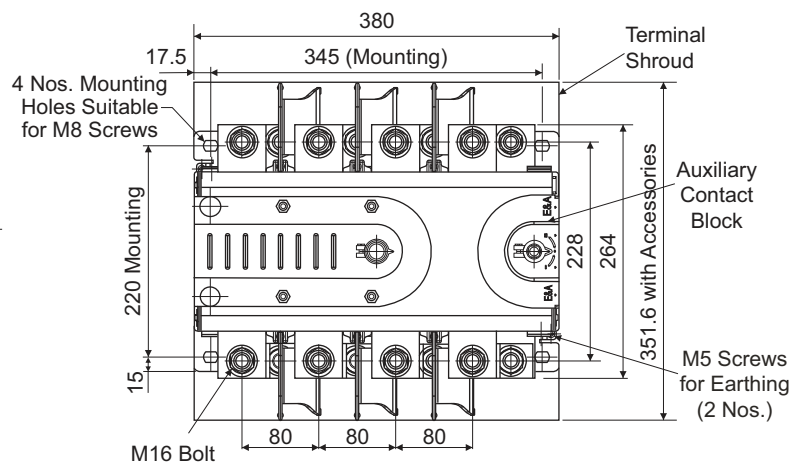

All dimensions are in mm

Dimensions

CO6-1250/1600

Open Execution with Extended Handle Manual Changeover Switch with center operation

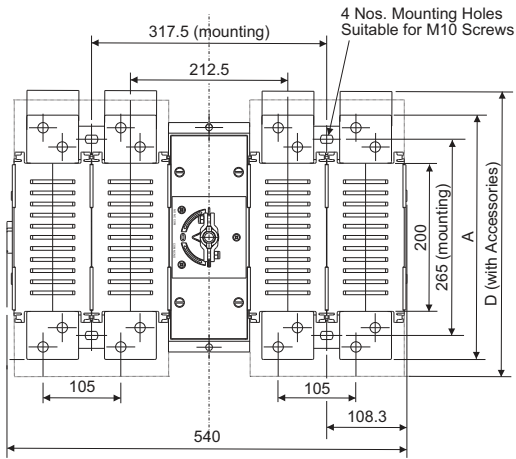

1250A Terminal Arrangement

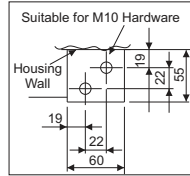

Type Designation	Terminal Screws	Tightening Torque
CO6-1250	M10 Hexagonal Head Bolt	20 N-m
CO6-1600	M12 Hexagonal Head Bolt	27 N-m

1600A Terminal Arrangement

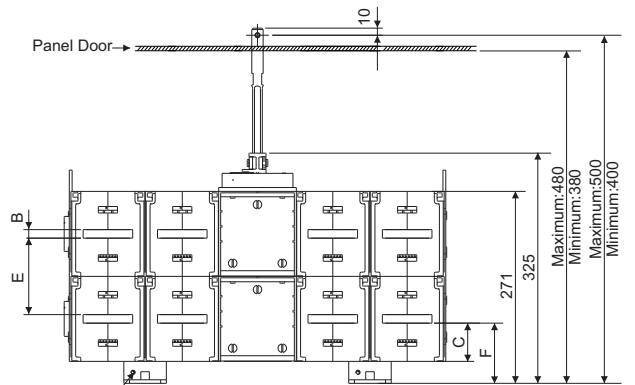
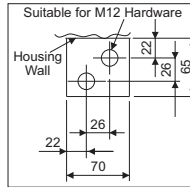

Cat. No.	Rating	A	B	C	D	E	F
CO612500000	CO6-1250	310	8	56	339	112	87
CO616000000	CO6-1600	330	12	54	347	108	85

Tapped Hole Suitable for M5 Screw for Earthing (25 Sq. mm Cable Lug)

CO6-1250/1600

Open Execution with Extended Handle Manual Changeover Switch with side operation

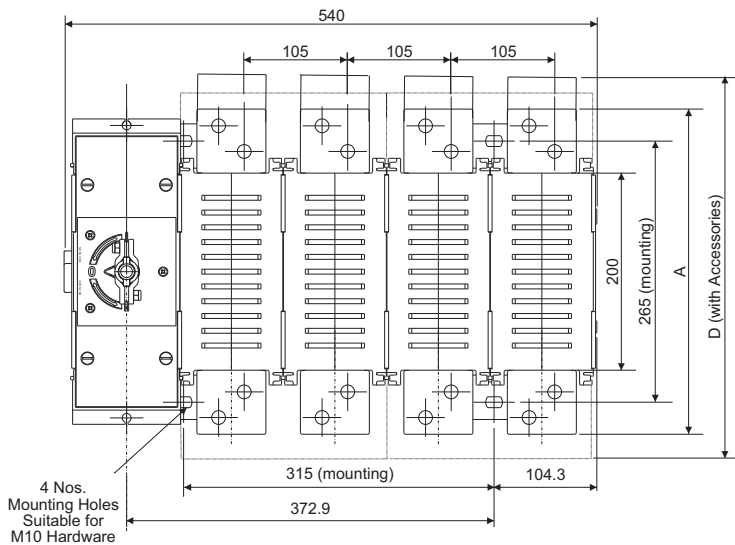

Cat. No.	Rating	A	B	C	D	E	F
CO6125000S0	CO6-1250	310	8	56	339	112	87
CO6160000S0	CO6-1600	330	12	54	347	108	85

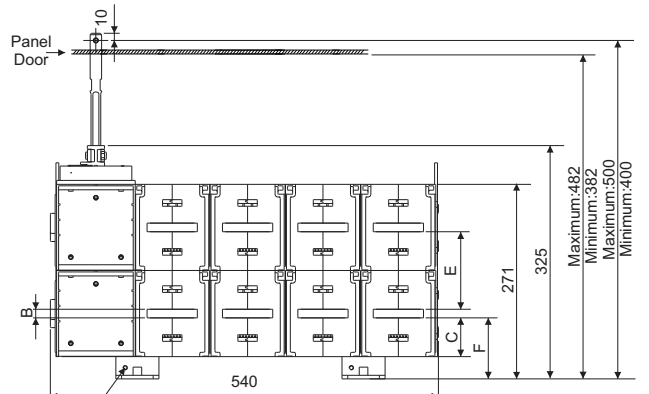

Tapped Hole Suitable for M5 Screw for Earthing (25 Sq. mm Cable Lug)

All dimensions are in mm

Dimensions

CO6-2000

Open Execution with Extended Handle Manual Changeover Switch with center operation

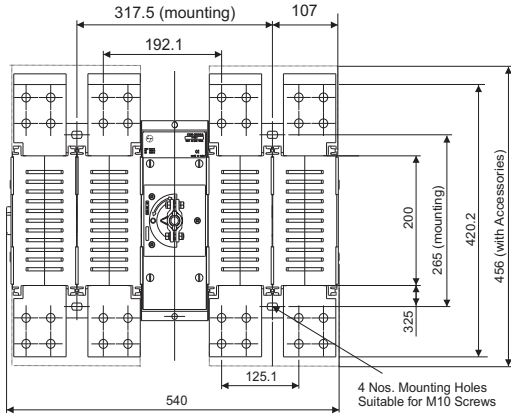

Terminal Arrangement

Suitable for M12 Hardware

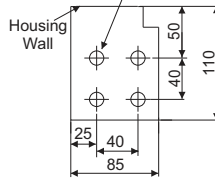

Type Designation	Terminal Screws	Tightening Torque
CO6-2000	M12 Hexagonal Head Bolt	27 N-m

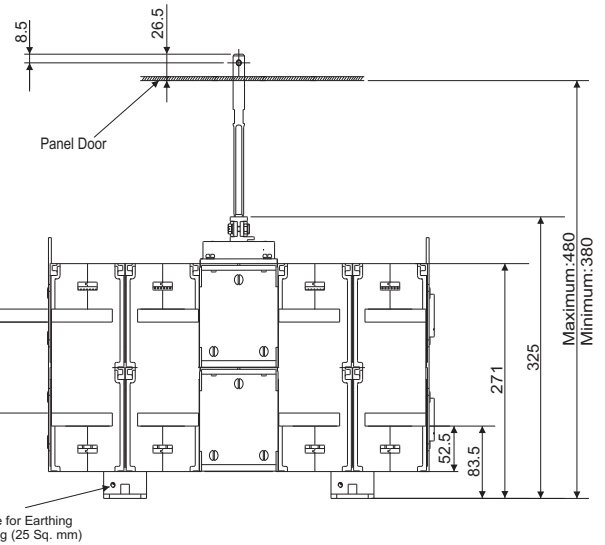

CO6-2000A

Termination of 100 mm Bus Bar

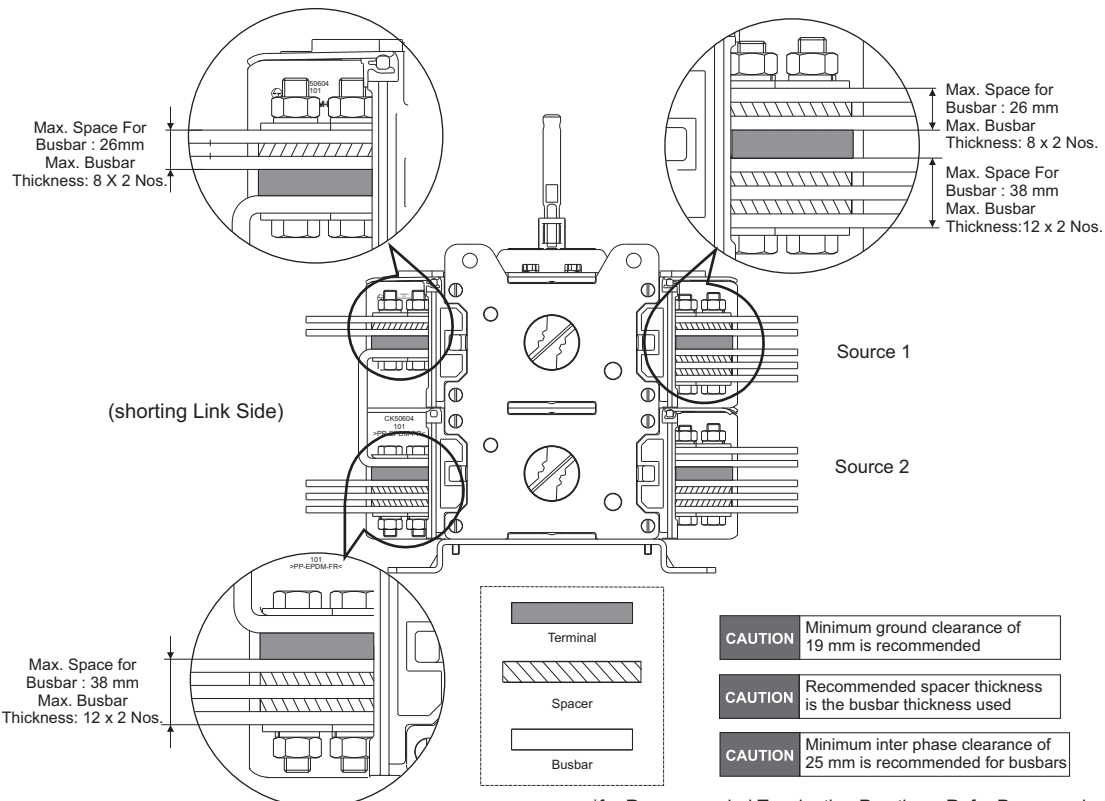

All dimensions are in mm

*for Recommended Termination Practices, Refer Page number 34

Dimensions

Recommended termination practices for busbar width 60-80 mm with diagonal hole configuration

Busbar Configuration 1 (1+1)

Busbar Configuration 2 (1+2)

Busbar Configuration 3 (2+2)

Busbar Configuration 4 (2+3)

Legend: Terminal, Spacer, Busbar

Busbar sizes as per standard

Busbar	1250 A	1600 A	2000 A
Cu	80 x 5 x 2nos	100 x 5 x 2nos	100 x 5 x 3nos
*Al	63 x 12 x 2nos	50 x 8 x 4nos	100 x 10 x 3nos

*For Aluminium termination as per standard:
 1250A: Factory fitted hardware to be used,
 1600/2000A: Bolt length of 85 mm to be used.

- Note: 1. Different configurations of busbars can be used maintaining minimum cross section areas as specified in the table
 2. Factory supplied bolt length caters to the copper bus bar termination as per standard. In case of different configurations & cross section areas, bolt of higher length may be required.

Termination of 100 mm Bus Bar 1600 A

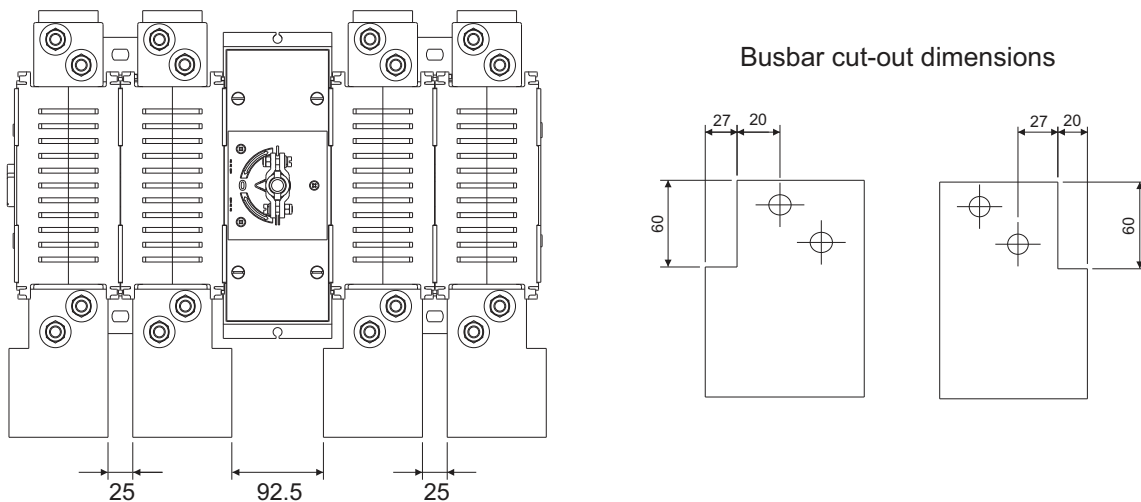

CO6-2000 A Termination of 100 mm Bus Bar

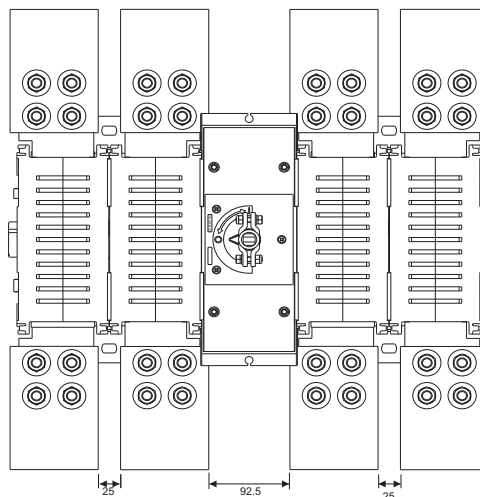

Direct termination of 100 mm bus bar possible in case of 2000 A.

All dimensions are in mm

Dimensions

CO1-63/100/125

Manual Changeover Switch In Sheet Steel Enclosure

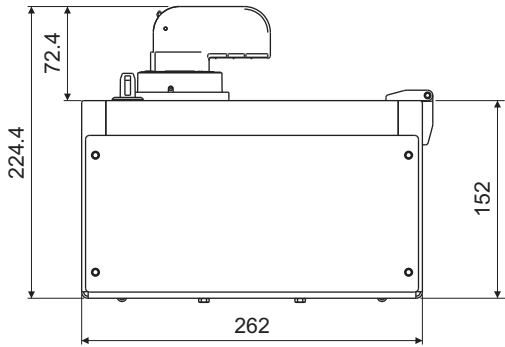

Rating	Termination Bolt
CO1-63/100/125 A	M6

RATING	A	B	C	D
CO1- 63 A	240	310	35	155
CO1- 100 A	240	310	35	155
CO1-125A	350	431	40.5	215.5

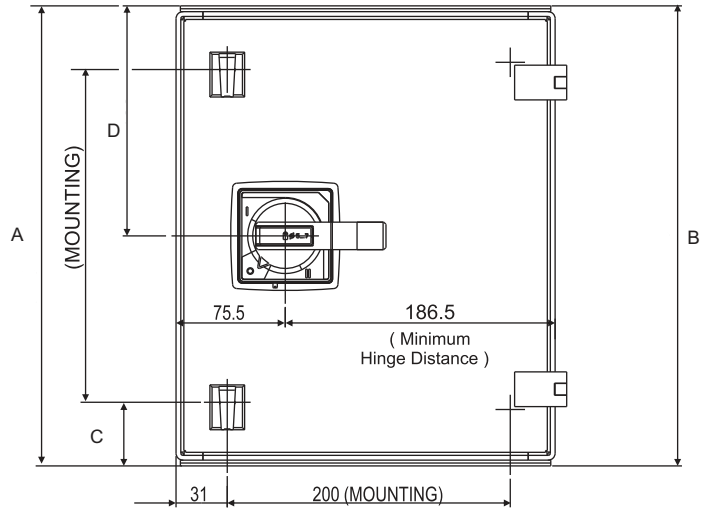

CO2-125/160/200

Manual Changeover Switch In Sheet Steel Enclosure

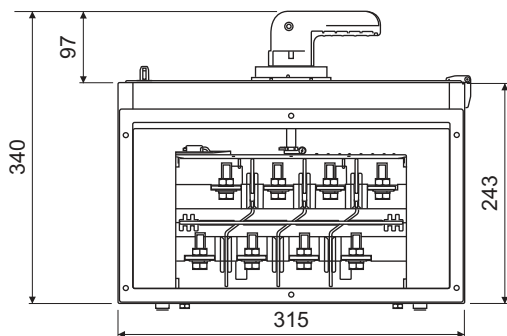

4 Nos. Mounting Holes Suitable for M8 Screws

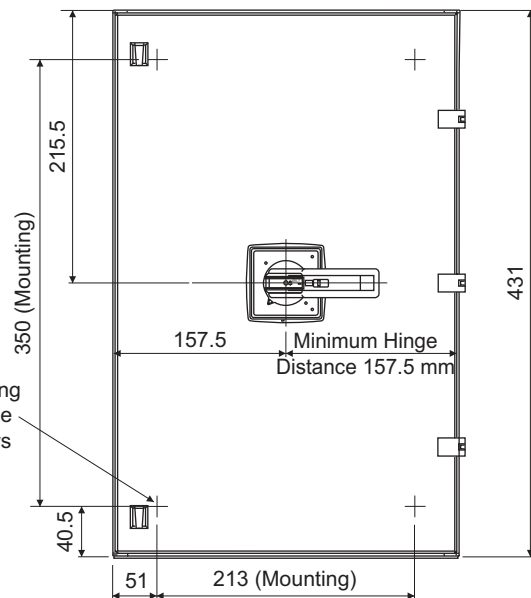

All dimensions are in mm

Dimensions

CO3-250/315 Manual Changeover Switch In Sheet Steel Enclosure

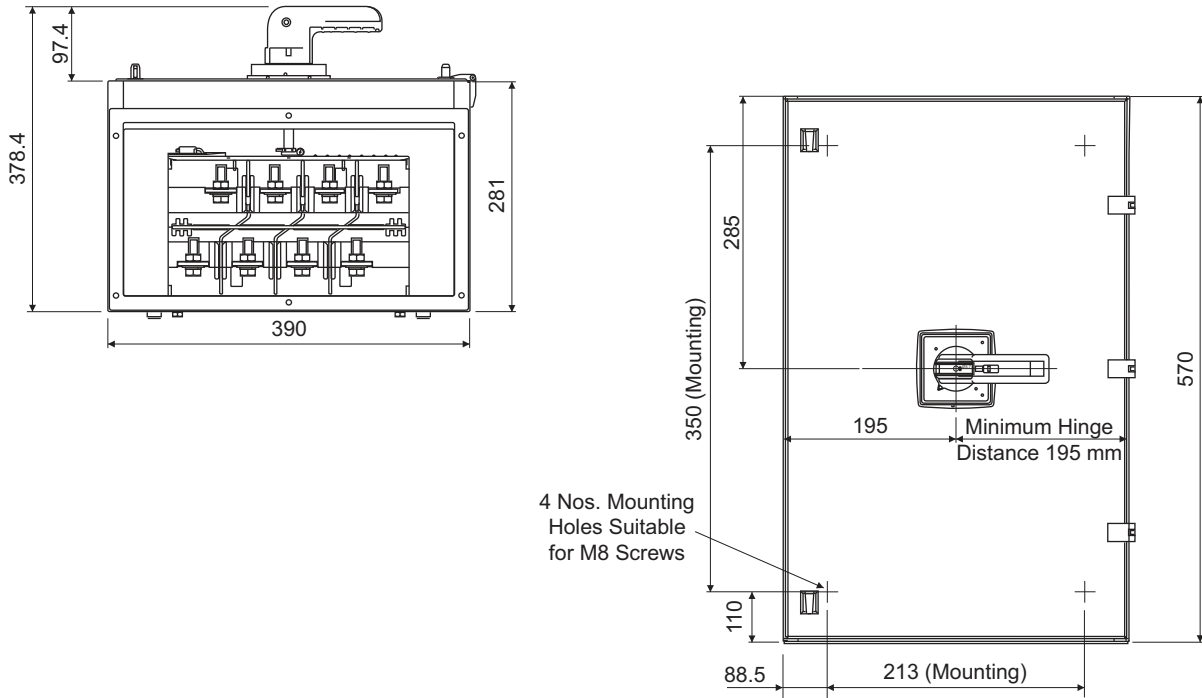

CO4-400/630 Manual Changeover Switch In Sheet Steel Enclosure

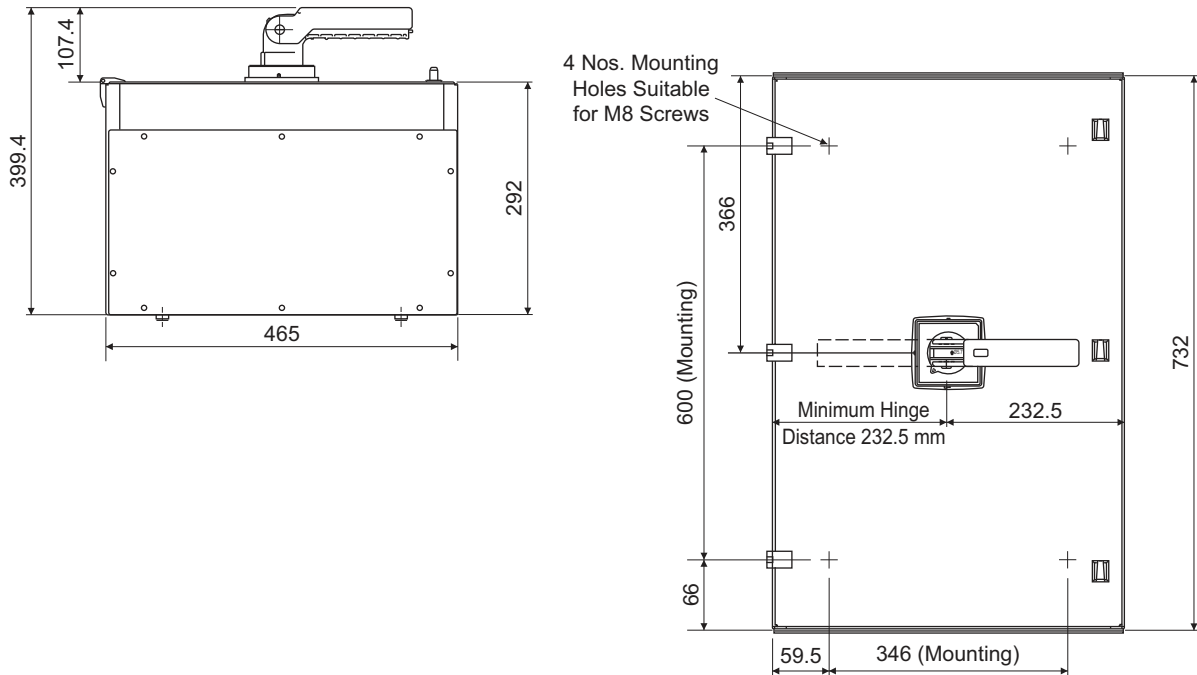

All dimensions are in mm

Dimensions

CO5-800/1000 Manual Changeover Switch In Sheet Steel Enclosure

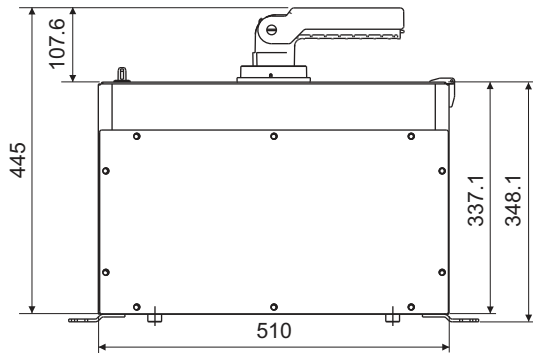

4 Nos. Mounting Holes Suitable for M10 Screws

Suitable For Lifting and Mounting with M10 Screws

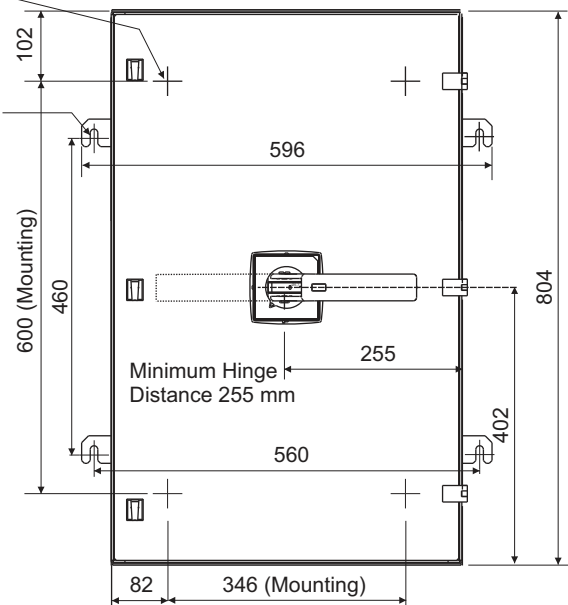

Dimensions

CO1-63

Fuse Changeover Switch (Suitable for Cylindrical Type Fuse Link)

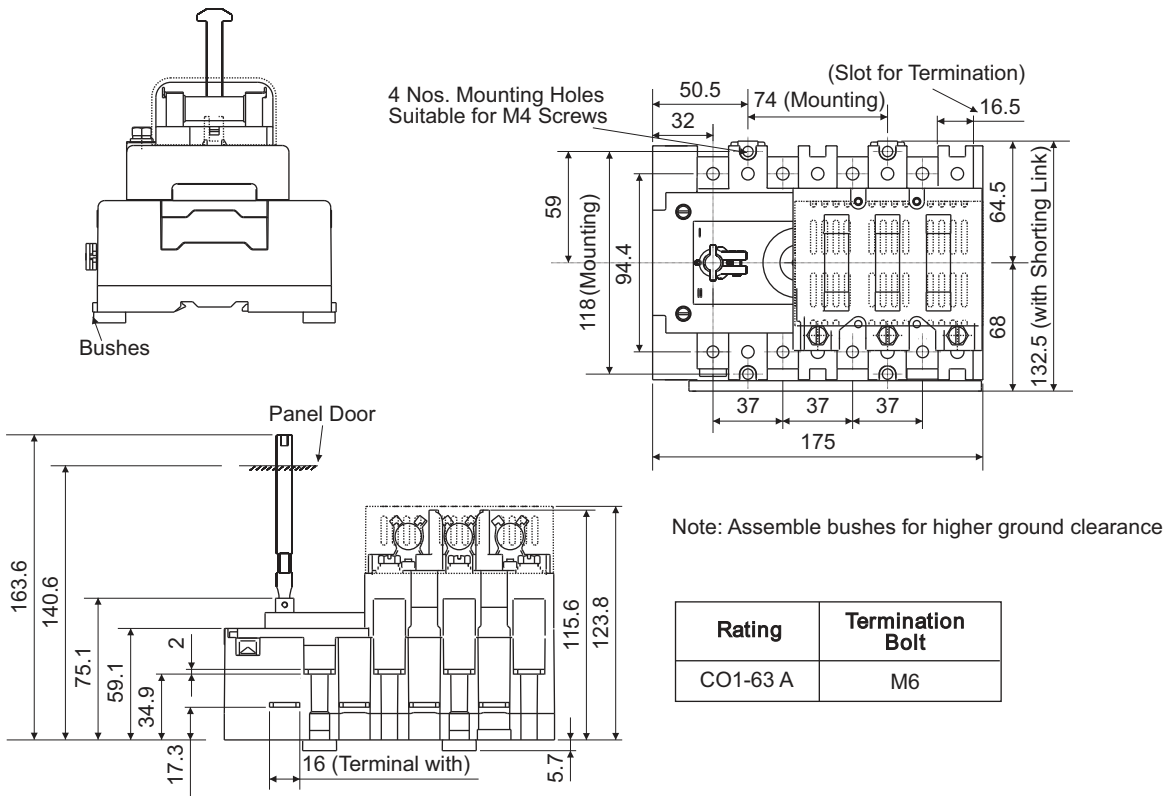

CO2-125/160/200

Fuse Changeover Switch (Suitable for DIN Type Fuse Link)

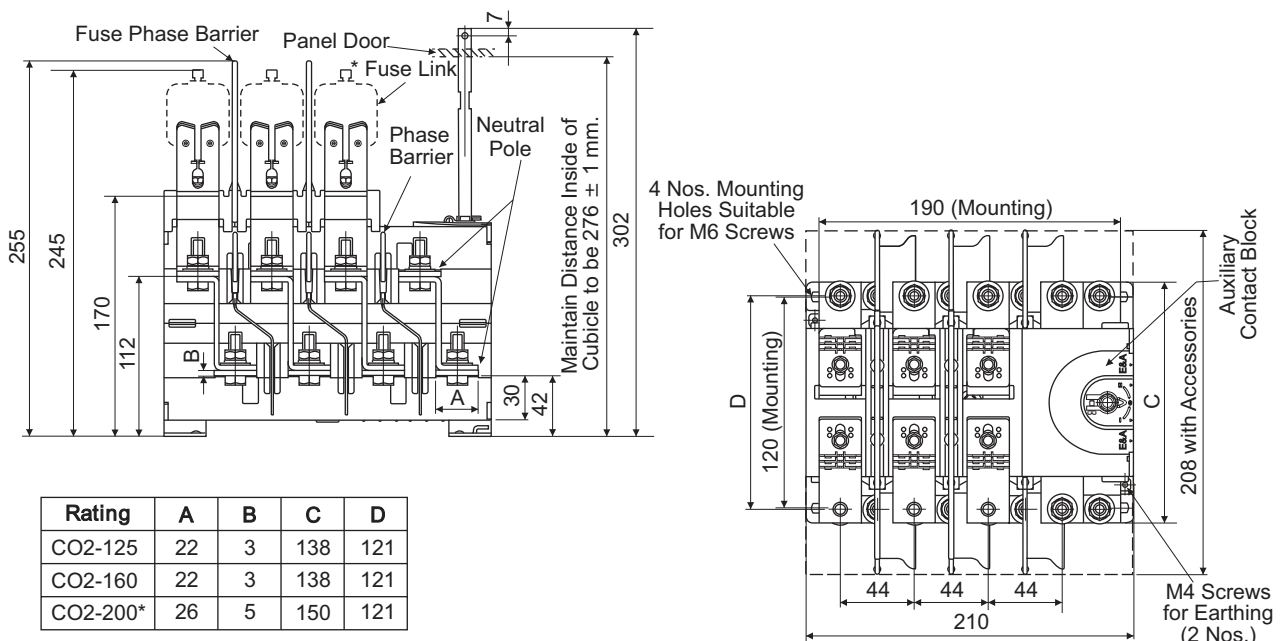

* Cat no. CO22000000 is of Interior CO2-200 suitable for fuse mounting kit CX22000000

Dimensions

CO3-250/315

Fuse Changeover Switch (Suitable for DIN Type Fuse Link)

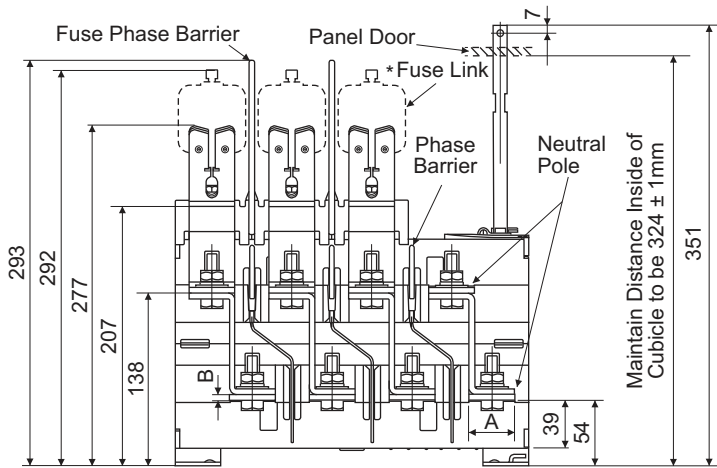

Rating	A	B	C	D
CO3-250	29	4.5	182	156
CO3-315	35	5	198	164

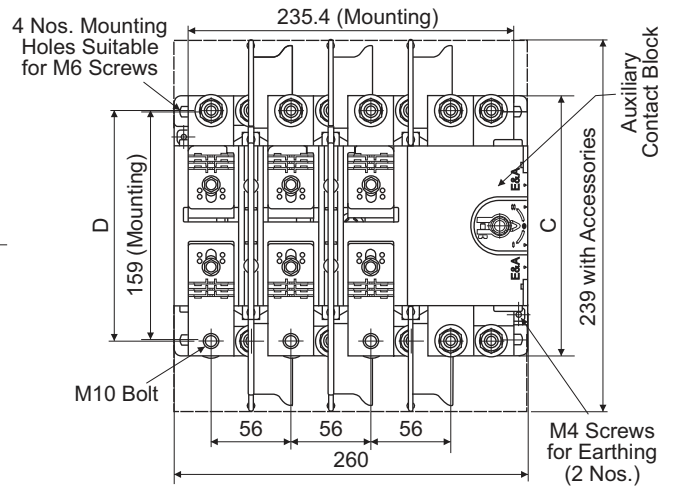

CO4-400

Fuse Changeover Switch (Suitable for DIN Type Fuse Link)

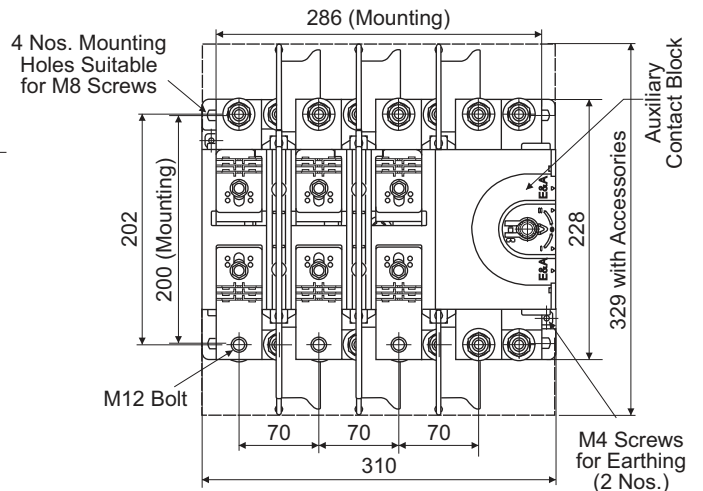
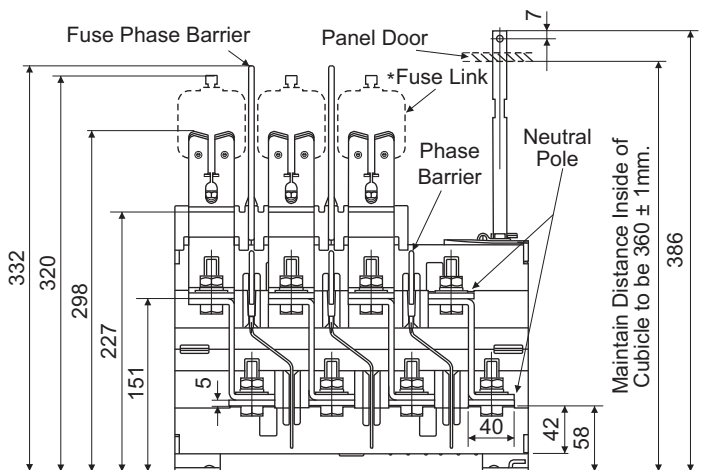

All dimensions are in mm

Dimensions

CO5-630/800

Fuse Changeover Switch (Suitable for DIN Type Fuse Link)

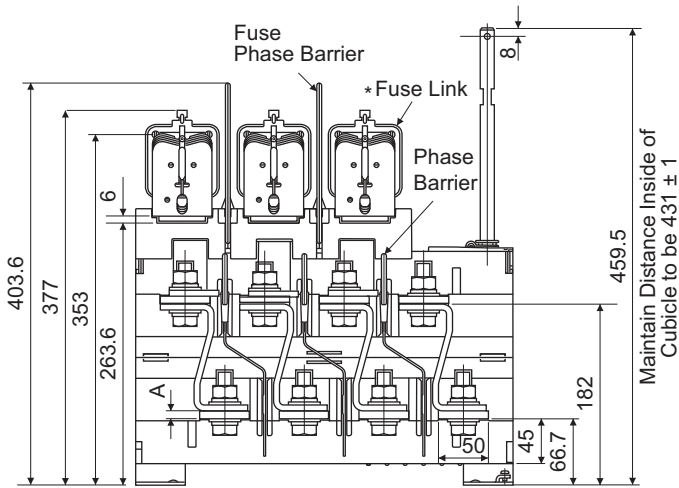

Rating	A
CO5-630	6
CO5-800	8

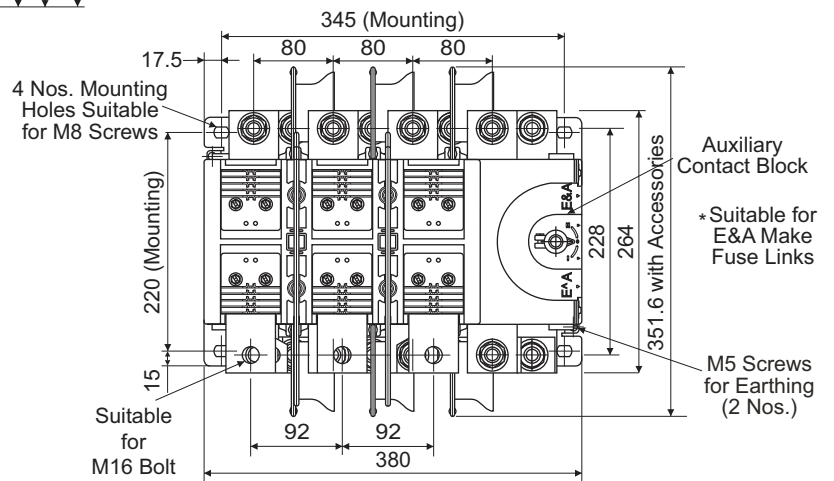

All dimensions are in mm

Dimensions

CO2 to CO5 (125-1000A) Motorised Changeover Switch

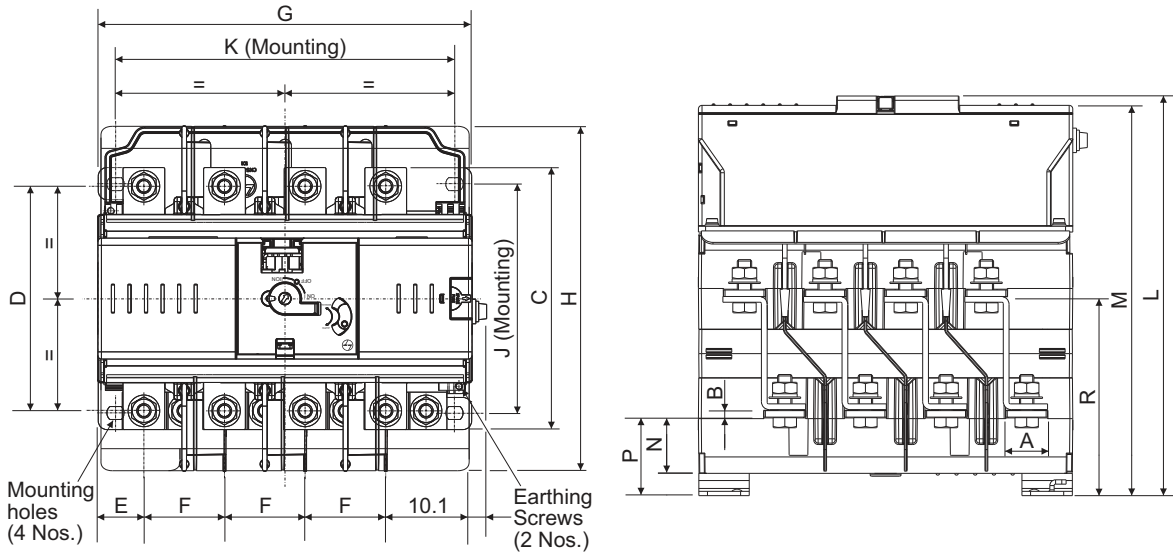

Rating (A)	Frame		A	B	C	D	E	F	G	H	J	K
	CO	EOM										
125	CO2	CX2	22	3	138	121	28	44	210	211	120	190
160			22	3	138	121	28	44	210	211	120	190
200			22	3	138	121	28	44	210	211	120	190
250	CO3	CX3	29	4.5	182	156	32	56	260	239	159	235.4
315			35	5	198	164	32	56	260	239	159	235.4
400	CO4	CX4	40	5	228	202	32.3	70	310	329	200	286
630			40	6	228	202	32.3	70	310	329	200	286
630	CO5	CX5	50	6	264	228	-	80	380	351.6	220	345
800			50	8	264	228	-	80	380	351.6	220	345
1000			50	8	264	228	-	80	380	351.6	220	345

Frame		L	M	N	P	R	Mounting Hole Size	Earthing Screw Size
CO	EOM							
CO2	CX2	240.3	234.3	30	42	112	M6	M4
CO3	CX3	277.2	271.2	39	54	138	M8	M4
CO4	CX4	293.7	287.7	42	58	151	M8	M4
CO5	CX5	330.9	324.9	45	66.7	182	M8	M5

CO6-1250/1600/2000 Motorised Changeover Switch

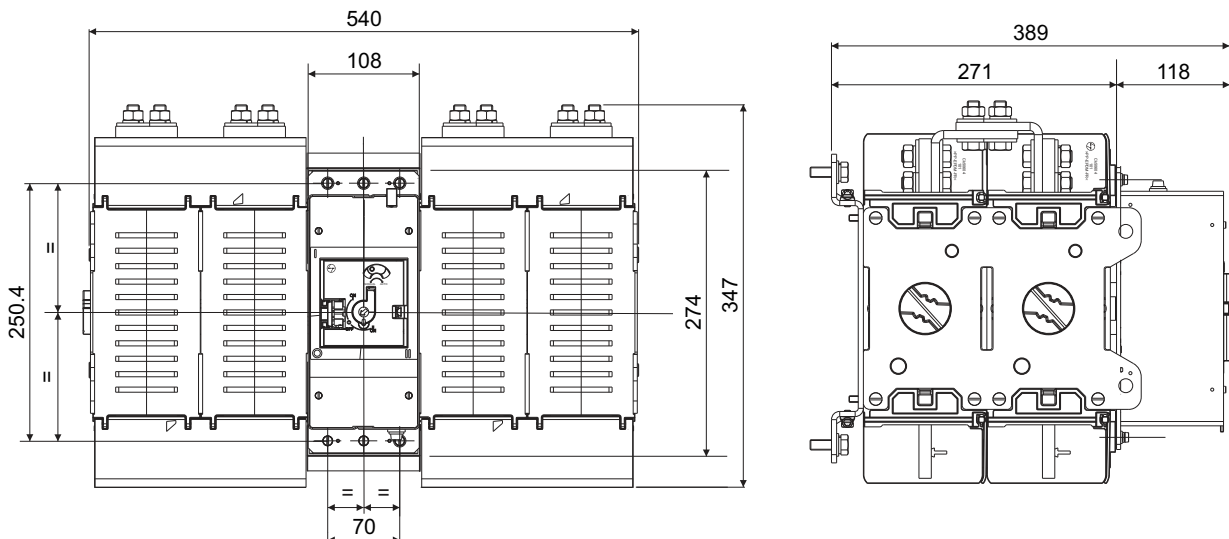

All dimensions are in mm

Dimensions

Panel Cutout Motorised Changeover Switch

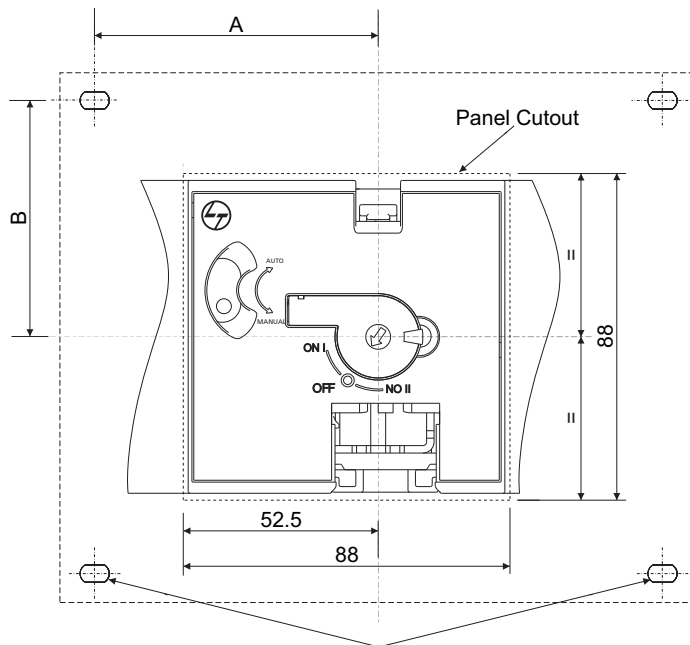

Type	A	B
CO2 with CX2	95	60
CO3 with CX3	117.7	79.5
CO4 with CX4	143	100
CO5 with CX5	172.5	110

Mounting Holes of Respective Changeover Switch

Drilling Plan for Mounting Bezel* Motorised Changeover Switch

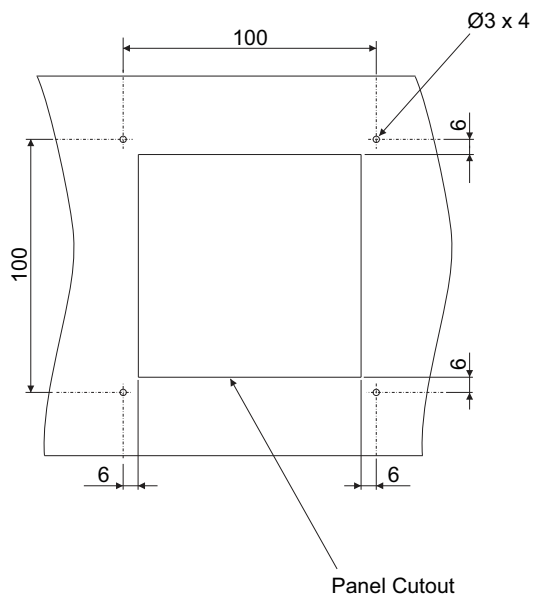

Bezel Assembly

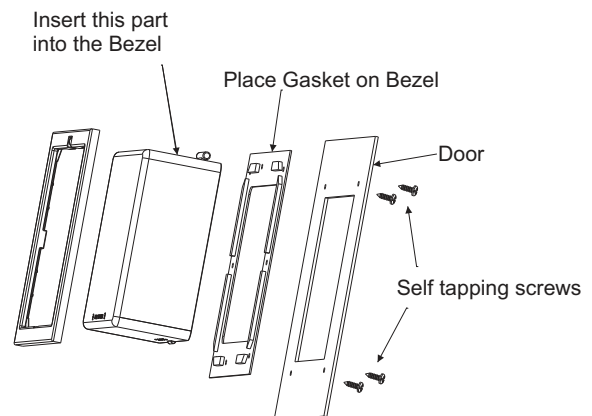

* Available with standard product.

All dimensions are in mm

Dimensions

AuXC-2000 Rear Terminal Connections

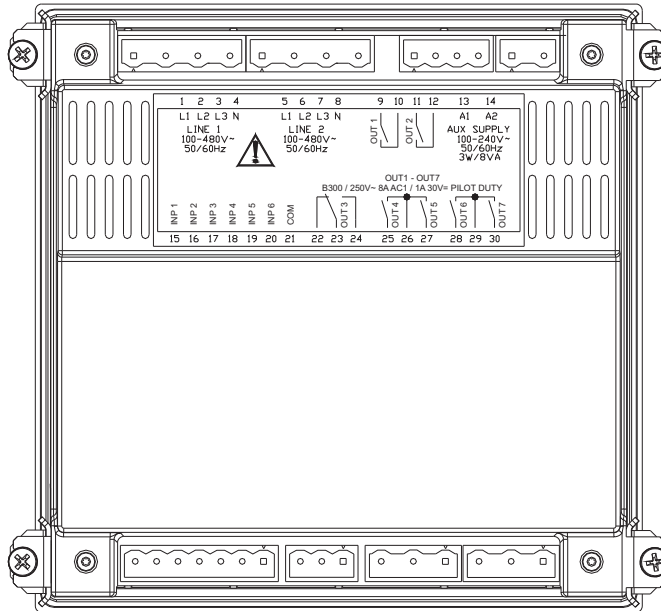

AuXC-2000 Panel cut-out

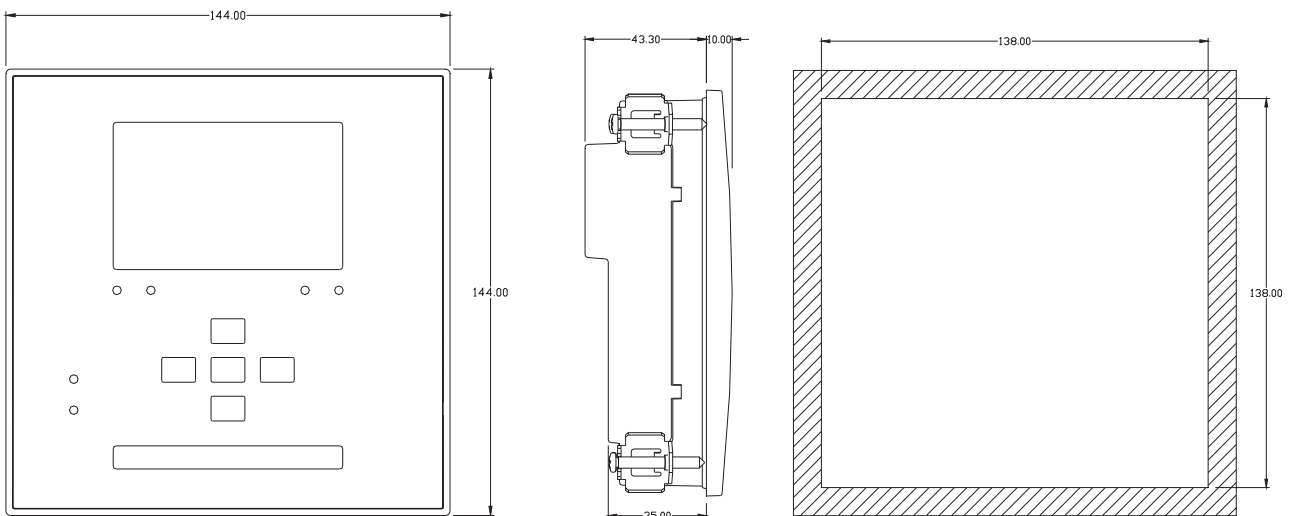

All dimensions are in mm

Dimensions

AST Controller Panel Cutout & Drill Plan for Flush Mounting

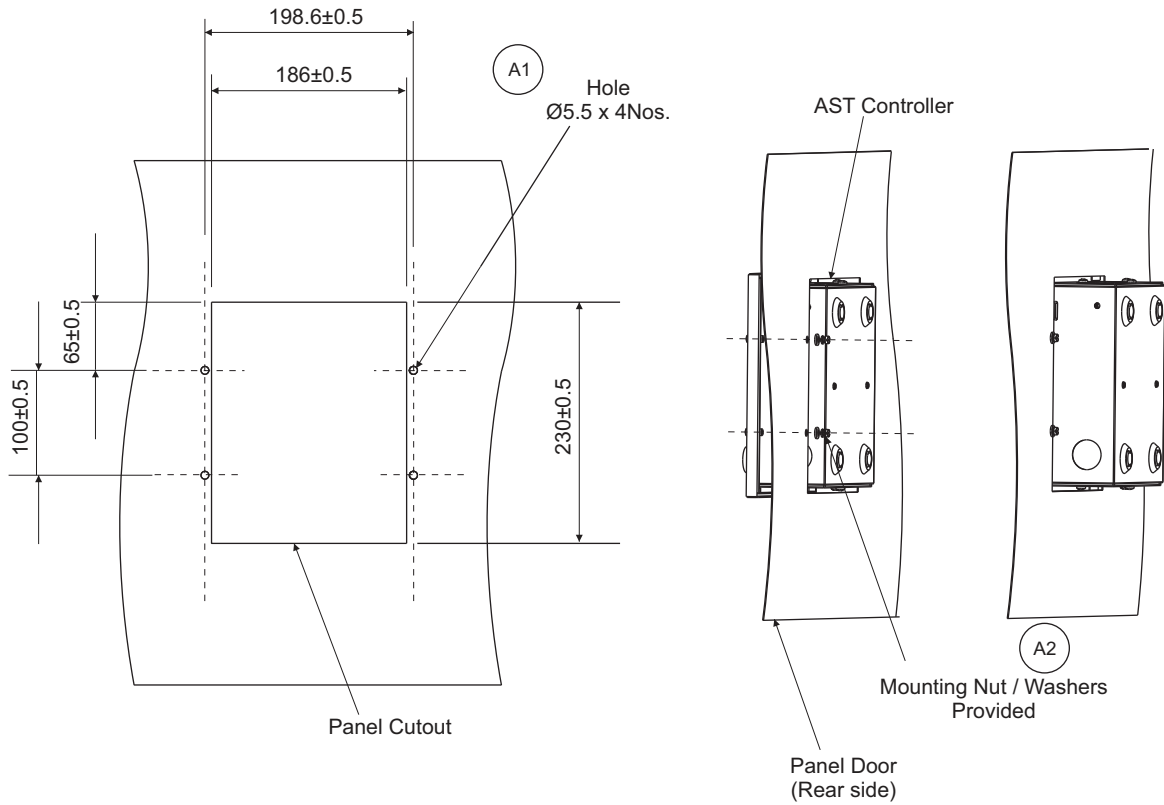

Enclosed ATS Overall Dimensions

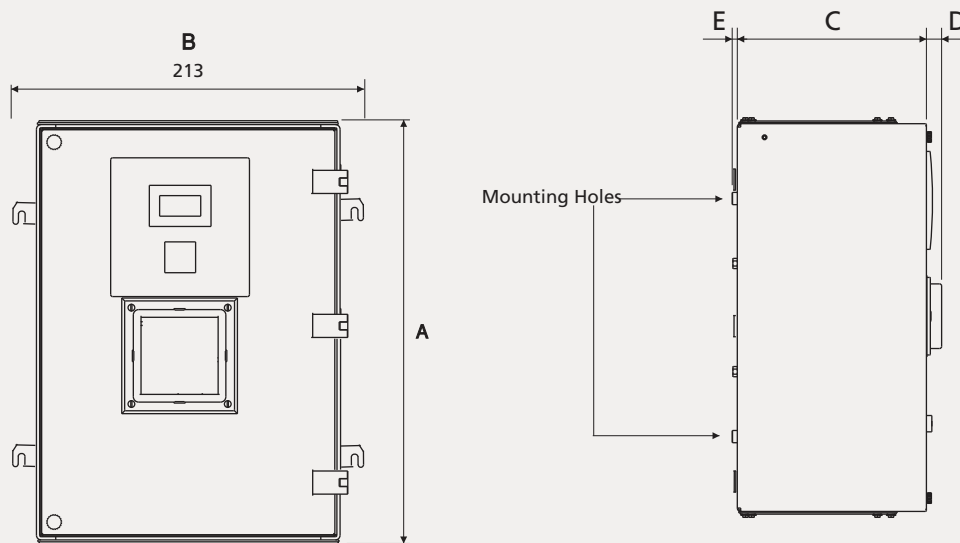

RATING (A)	A	B	C	D	E	MOUNTING HOLE SIZE
125/160/200	439	409	243	66	7.5	M8
250/315	578	486	278	66	7.5	M8
400/630	740	561.2	297	66	7.5	M8

Dimensions for Enclosure Mounting

RATING(A)	A	B	C	D
125/160/200	51	213	44.5	350
250/315	88.5	213	114	350
400/630	59.5	346	70	600

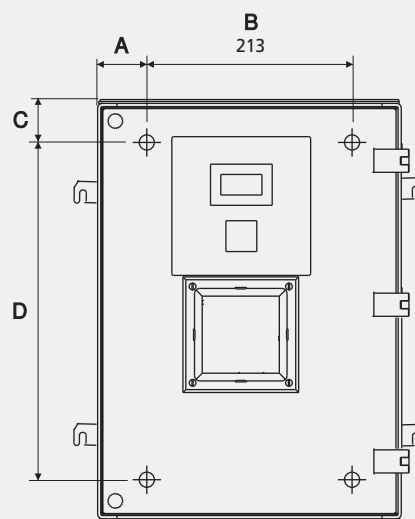

Enclosed ATS

Handle Clamp & IP Cover Mounting

Clamp Mounting for Handle

- Remove the screws and fix clamp to the enclosure as shown.
- Keep the handle inside the clamp when not in use.

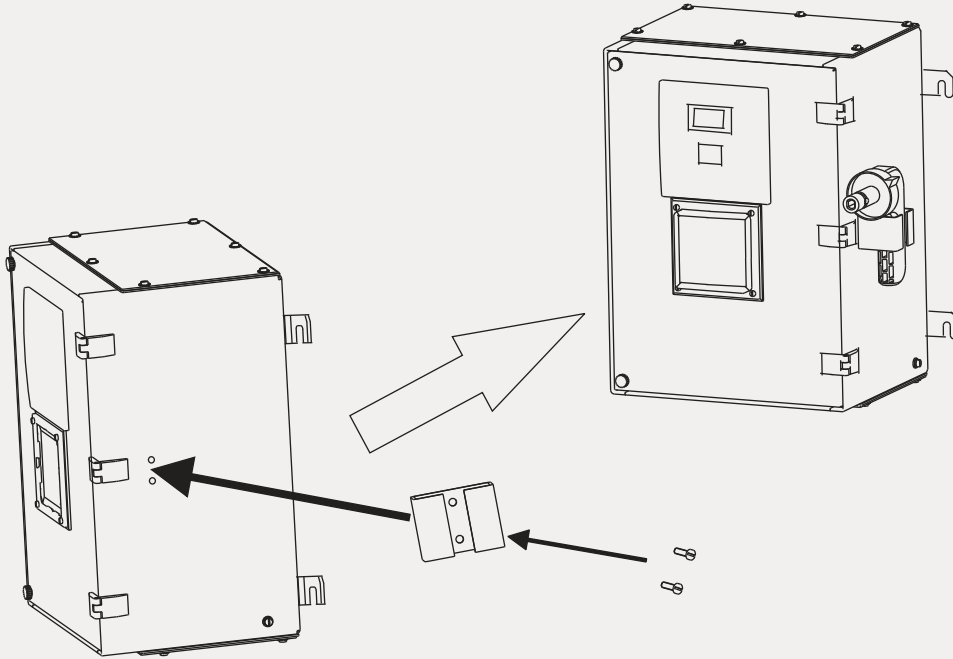

IP Cover Mounting

Insert the IP cover as shown

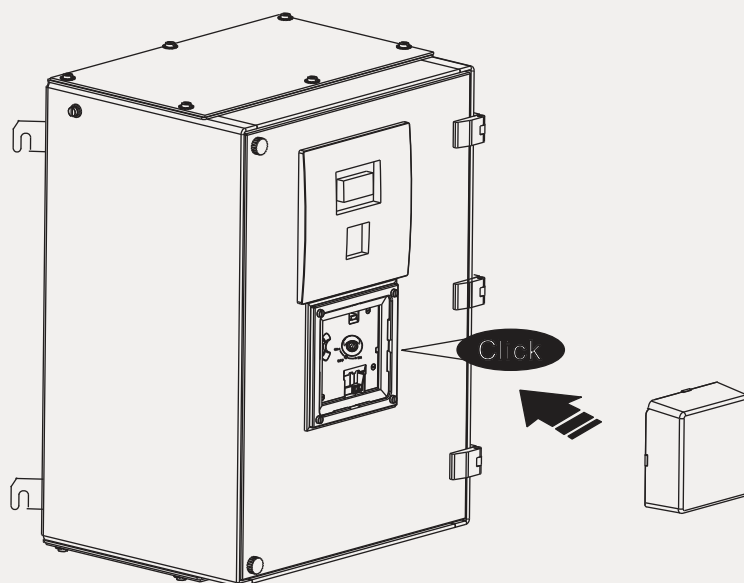

Caution: Remove IP cover for manual operation.

Electrical Standard Products (ESP) Offices:

HEAD OFFICE

L&T Electrical & Automation
TC-II, Tower B, Prima Bay,
Gate No. 5, Saki Vihar Road, Powai,
MUMBAI - 400072.
Tel: 022-67052874 / 2737 / 1156
e-mail: cic@Lntebg.com

BRANCH OFFICES

L&T Electrical & Automation
C-201, The First Commercial Complex,
B/S Keshavbaug Party Plot, Vastrapur,
Ahmedabad - 380015
Toll Free: 1800 233 5858 / 1800 200 5858
e-mail: CIC@Lntebg.com

L&T Electrical & Automation
Wework Central, #36 Infantry Road,
Bengaluru - 560 001
Toll Free: 1800 233 5858 / 1800 200 5858
e-mail: CIC@Lntebg.com

L&T Electrical & Automation
Under O Launchpad, 4th floor,
Unit-434, Esplanade 1, Rasulgarh,
Bhubaneswar - 751010
Toll Free: 1800 233 5858 / 1800 200 5858
e-mail: CIC@Lntebg.com

L&T Electrical & Automation
4th floor, SCO-54,55,56,
Sector -17A
Chandigarh - 160017
Toll Free: 1800 233 5858 / 1800 200 5858
e-mail: CIC@Lntebg.com

L&T Electrical & Automation
Olympia Technology Park,
10th Floor, CITIUS A Block,
Plot No. 1, Phase 1, Guindy,
Chennai - 600032
Toll Free: 1800 233 5858 / 1800 200 5858
e-mail: CIC@Lntebg.com

L&T Electrical & Automation
Playworkz Coworking Space
43 & 44, 3rd Cross,
Bharathy Colony, Peelamedu,
Coimbatore - 641004
Toll Free: 1800 233 5858 / 1800 200 5858
e-mail: CIC@Lntebg.com

L&T Electrical & Automation
3rd Floor, 1&2 Vijay Park,
Main Chakrata Road, Opp. Anandam
Near Ballapur chowk,
Dehradun - 248001
Toll Free: 1800 233 5858 / 1800 200 5858
e-mail: CIC@Lntebg.com

L&T Electrical & Automation
Ground Floor, B-27, Biplab Rashbihari Sarani,
Sector 2A, Bidhan Nagar,
Durgapur - 713212
Toll Free: 1800 233 5858 / 1800 200 5858
e-mail: CIC@Lntebg.com

L&T Electrical & Automation
6th floor, Exotica Greens, A Block, 191,
R G Baruah Road, Guwahati Central,
Guwahati - 781005
Toll Free: 1800 233 5858 / 1800 200 5858
e-mail: CIC@Lntebg.com

L&T Electrical & Automation
Shri Daneshwari, 1st Floor,
Plot No. 17, 2nd Cross,
Near Old Income Tax Office Road,
Vidyanagar,
Hubballi - 580021
Toll Free: 1800 233 5858 / 1800 200 5858
e-mail: CIC@Lntebg.com

L&T Electrical & Automation
AWFIS space solutions, Prestige Phoenix,
4th floor, 1405, Umanagar, Begumpet,
Hyderabad - 500016
Toll Free: 1800 233 5858 / 1800 200 5858
e-mail: CIC@Lntebg.com

L&T Electrical & Automation
Workie, 214 - 2nd Floor,
Apollo Premier, PU-4,
Scheme No. 54,
Vijay Nagar Square,
Indore - 452010
Toll Free: 1800 233 5858 / 1800 200 5858
e-mail: CIC@Lntebg.com

L&T Electrical & Automation
Office No 430, 4th floor,
Jaipur Electronic Market
Riddhi Siddhi,
Gopalpura Bypass,
Jaipur - 302018
Toll Free: 1800 233 5858 / 1800 200 5858
e-mail: CIC@Lntebg.com

L&T Electrical & Automation
GDR Siddha, Ground Floor, N Road
Bistupur, Opposite St. Mary's Church,
Jamshedpur - 831001
Toll Free: 1800 233 5858 / 1800 200 5858
e-mail: CIC@Lntebg.com

L&T Electrical & Automation
Business Communication Centre
2nd Floor, Chiramel Chambers,
Kurisupally Road,
Ravipuram,
Kochi - 682 015
Toll Free: 1800 233 5858 / 1800 200 5858
e-mail: CIC@Lntebg.com

L&T Electrical & Automation
2nd Floor, BN3, Salt Lake, Sector-V,
Kolkata - 700091
Toll Free: 1800 233 5858 / 1800 200 5858
e-mail: CIC@Lntebg.com

L&T Electrical & Automation
No. 10, Fortuna Towers, 2nd floor,
Rana Pratap Marg, Near NBRI
Lucknow - 226001
Toll Free: 1800 233 5858 / 1800 200 5858
e-mail: CIC@Lntebg.com

L&T Electrical & Automation
El Dorado Building 3rd Floor,
6, Venkatraman Street,
Chinna Chokkikulam
Madurai - 625 002
Toll Free: 1800 233 5858 / 1800 200 5858
e-mail: CIC@Lntebg.com

L&T Electrical & Automation
TC II, Tower B, PRIMA BAY
Gate no. 5, Saki Vihar Road Powai,
Mumbai - 400072
Toll Free: 1800 233 5858 / 1800 200 5858
e-mail: CIC@Lntebg.com

L&T Electrical & Automation
Unnati Building, 2nd floor,
Automation Campus, A-600, TTC Industrial area
Shil-Mahape road, Mahape
Navi Mumbai - 400710
Toll Free: 1800 233 5858 / 1800 200 5858
e-mail: CIC@Lntebg.com

L&T Electrical & Automation
M1 & M2, Mezzanine Floor,
Himalaya Excellency, Plot No - C - 47,
Pratap Nagar Square,
Nagpur - 440022
Toll Free: 1800 233 5858 / 1800 200 5858
e-mail: CIC@Lntebg.com

L&T Electrical & Automation
A-25, 1st Floor, Imperia Complex,
Mohan Corporative Industrial Estate,
Near Sarita Vihar Metro Station,
Mathura Road,
New Delhi - 110044
Toll Free: 1800 233 5858 / 1800 200 5858
e-mail: CIC@Lntebg.com

L&T Electrical & Automation
A06/A07, Second Floor,
Grand Chandra complex, Frazer road
Patna - 800001
Toll Free: 1800 233 5858 / 1800 200 5858
e-mail: CIC@Lntebg.com

L&T Electrical & Automation
UrbanWrk, 5th Floor, Sai Radhe,
Raja Bahadur Mill road, Behind Hotel
Grand Sheraton, Sangamwadi
Pune - 411001
Toll Free: 1800 233 5858 / 1800 200 5858
e-mail: CIC@Lntebg.com

L&T Electrical & Automation
Unit No. 207, 2nd Floor, Wallfort Ozone,
Raipur Road, Near Fafadih Chowk,
Raipur - 492001
Toll Free: 1800 233 5858 / 1800 200 5858
e-mail: CIC@Lntebg.com

L&T Electrical & Automation
10th Floor, Titaanium Business,
Bhimrad Road, Althan
Surat - 395017
Toll Free: 1800 233 5858 / 1800 200 5858
e-mail: CIC@Lntebg.com

L&T Electrical & Automation
11th Floor, Block-D, Notus IT Park,
Sarabhai Campus, Bhalil Amin Marg,
Vadodara - 390023
Toll Free: 1800 233 5858 / 1800 200 5858
e-mail: CIC@Lntebg.com

L&T Electrical & Automation
414, 4th Floor, Naga Chambers,
Opposite HDFC Bank
Ram Nagar, Waltair Main Road
Visakhapatnam - 530002
Toll Free: 1800 233 5858 / 1800 200 5858
e-mail: CIC@Lntebg.com

Product improvement is a continuous process, For the latest information and special application, please contact any of our offices listed here.
Product photographs shown for representative purpose only.



L&T Electrical & Automation, Electrical Standard Products
TC-II, Tower B, Prima Bay, 3rd Floor, Gate No. 5, Saki Vihar Road, Powai,
Mumbai - 400 072, INDIA. Web: www.Lntebg.com

Customer Interaction Centre (CIC)
BSNL/MTNL (toll-free): 1800 233 5858 Reliance (toll-free): 1800 200 5858
Tel: 022 6774 5858 Email:cic@Lntebg.com Web: www.Lntebg.com