

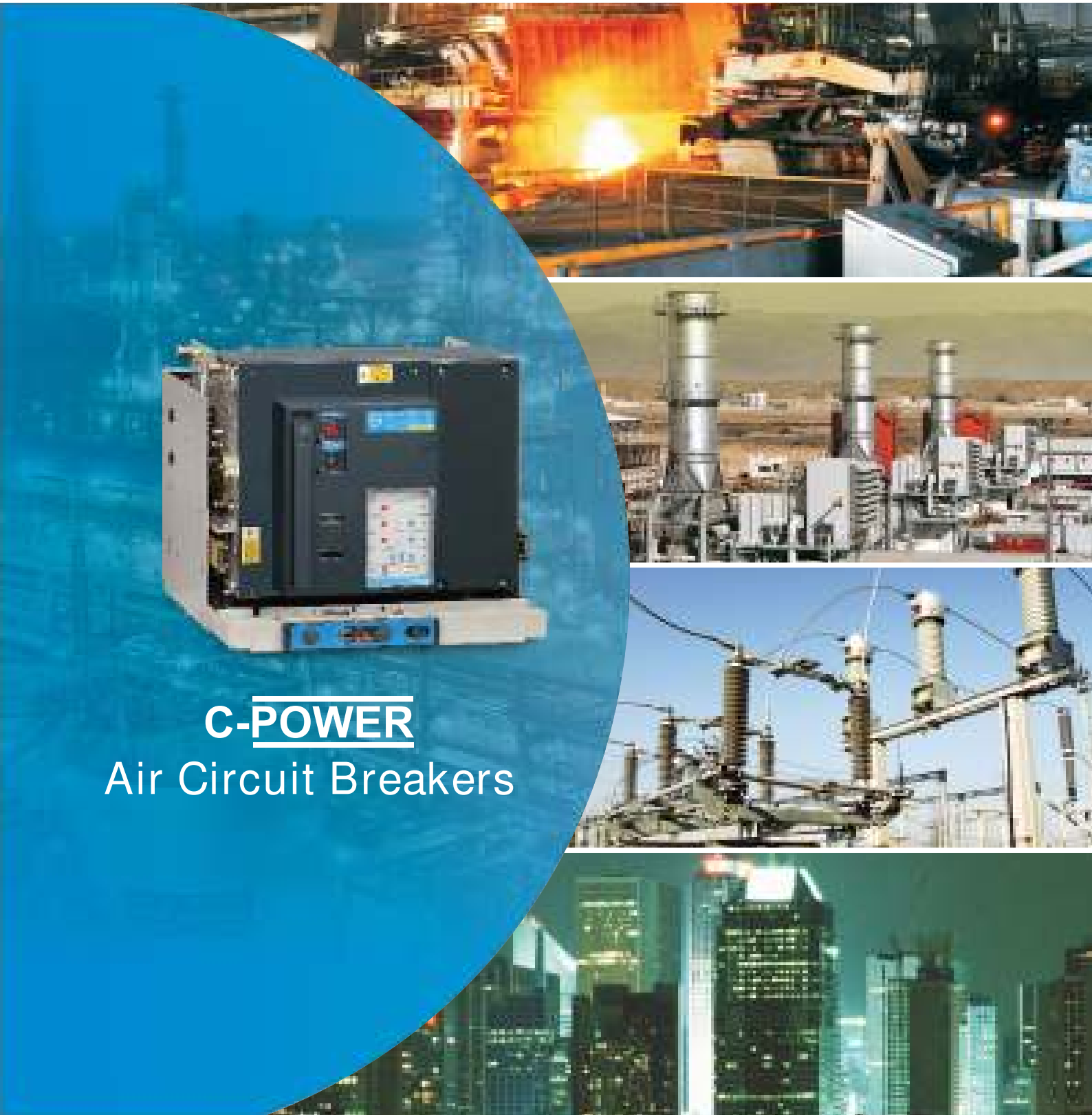

C-POWER
Air Circuit Breakers



ABOUT US



Switchgear Factory, Navi Mumbai



Switchgear Factory, Ahmednagar



Switchgear Factory, Vadodara

L&T Electrical & Automation (E&A) is a market leader for electrical distribution, monitoring and control solutions in the low voltage category.

Popular among customers as L&T Switchgear, E&A offers a wide range of low and medium voltage switchgear, motor starters, electrical systems, industrial automation, building electrical solutions, energy management solutions, electrical modernization solutions and metering solutions. Its products and solutions cater to key sectors of economy like industries, utilities, infrastructure, building and agriculture.

E&A's manufacturing operations at Navi Mumbai, Ahmednagar, Vadodara, Coimbatore and Mysuru in India adhere to global practices of excellence and receive support from well-equipped in-house design and development centres as well as tooling facilities that contribute to precision in manufacturing.

C-POWER AIR CIRCUIT BREAKERS

L&T Electrical & Automation's Air Circuit Breakers (ACBs) are specially designed for extreme tropical conditions and have a proven track record of more than 45 years. Presently more than 5,00,000 Air Circuit Breakers supplied by E&A are being used for diverse applications. The **C-POWER** Air Circuit Breakers provide technologically driven solutions to meet customer needs.



Complete selectivity

Unique feature of $I_{cu}=I_{cs}=I_{cw}$ for 1 second across the entire range. This ensures complete selectivity for system with time based discrimination.

Perfect for indian conditions

Inherent design to perform in extreme tropical conditions. Typical site conditions like high ambient temperature, humidity and dusty environment are best handled by **C-POWER** ACBs without compromising on performance and safety.

Optimal compactness

Designed to ensure

- Low inherent temperature rise
- Adequate interface clearances

Widest choice of over current protection releases

- Advance micro-controller based with option of communication & metering-SR71
- Micro processor based releases-SR18/SR18G/SR18G & SR18Gi with current metering
- Thermo-magnetic release-DN1

Elegant design & rugged construction

- Common door cutout for entire range
- Left aligned cutout for all ratings

Range to meet every customer's need

Various options to choose from

- Breaking capacity from 50kA to 100kA
- 3 Pole or 4 Pole configuration
- Fixed or Drawout version
- Auto reset mechanism
- Independent manual or stored energy type, manual or electrically operated mechanism
- Different terminal orientations : Flat, Horizontal and Vertical

New User Friendly Feature

- Operational Counter will be standard offering from rating 4000A and above

User Friendly Features

- Front accessible over current release settings, telescopic racking handle and various racking interlocks; no need to open the panel door
- Unique 'Maintenance position' in drawout type ACBs to facilitate maintenance & inspection without removing ACB from the panel
- Multitap CTs for enhancing protection range in DN1 release
- Wide variety of Amperemetric and Voltmetric releases
- Fully rated neutral pole for the entire range
- Lockable sliding shutters to prevent unauthorized access to "TRIP" and "CLOSE" push buttons
- Can be used as an ON / OFF Load Isolator
- Extendable Electrical Life:
 - By replacing the arcing contacts at site, for all ratings
 - Without changing pole assembly
- Programmable SICs: Auxiliary contacts in drawout ACBs are programmable for only Service, Only Test, Test and Service, and All Positions
- Protection releases are easily interchangeable at site
- Facility for site conversion of manually operated ACBs to electrically operated ACBs
- Jaws on breaker facilitate ease of maintenance & replacement of contact jaws

Safety

- Superior quality engineering grade plastics used for insulation purpose; conforms to Glow wire test (Ref: IEC 60695-2-1)
- In-built mechanical anti-pumping to prevent auto-reclosing of ACB on persisting faults
- In-built rating error preventor in drawout ACBs ensure correct rating of drawout portion in corresponding cradle
- Safety shutters prevent accidental contact with live cradle terminals
- Variety of Safety Interlocks
- Easily removable arc chutes without use of any tool
- Operating voltage ranges from 10% Un to 110% Un for shunt release ensures intentional tripping even at high voltage drops during short-circuit
- Transparent safety shutter offers easy inspection of cradle contacts & reduces the maintenance time

Conformance to Standards

- IEC - 60947 (Part 1 & 2)
- IS/IEC - 60947 (Part 1 & 2)
- IEC 60695 - 2 - 1
- BS EN 60947 - 2

Special Applications

690V Application for C-Power ACB

Solution for 690V application available in C-Power Family. For further details please consult our nearest branch office.

Breakers for Corrosive Environment

Solution for harsh/corrosive environment available in C-Power Family. For further details please consult our nearest branch office.

C-POWER RANGE



Breaking Capacities:

Icu = Ics = Icw for 1 sec

Rated Current	400A	630A	800A	1000A	1250A	1600A	2000A	2500A	3200A	4000A	5000A	6300A
CN-CS : E	50kA	50kA	50kA	50kA	50kA	50kA	50kA					
	Frame-1											
CN-CS : S1	50kA	50kA	50kA	50kA	50kA	50kA	50kA	60kA	60kA			
	Frame-1							Frame-2				
CN-CS : C			50kA	50kA	50kA	50kA	55kA	60kA			95kA	95kA
CN-CS : H			65kA	65kA	65kA	65kA	75kA	75kA				
CN-CS : H2									75kA	75kA		
CN-CS : H1/H									100kA	100kA		
			Frame-1				Frame-2		Frame-3		Frame-4	

Note : 3200A H2 / 4000A H2 will replace 3200A H0 / 4000A H0. Spares for 3200 / 4000 A H0 will be available.

TECHNICAL DATA SHEET



Rating (A)	400	630	400/630	800				1000				1250				1600				2000				2500			3200				4000			5000	6300				
Type Designation	E#	E#	S1	E#	S1	C	H	E#	S1	C	H	E#	S1	C	H	E#	S1	C	H	E#	S1	C	H	S1	C	H	S1	D	H2	H1	H2	H	C	C	C				
Rated current (A) at 50°C I_n	400	630		800				1000				1250				1600				2000				2500			3200				4000			5000	6300				
Rated operational voltage (V), 50/60Hz U_o	415	415		415				415				415				415				415				415			415				415			415	415				
Rated insulation voltage (V), 50/60Hz U_i	1000	1000		1000				1000				1000				1000				1000				1000			1000				1000			1000	1000				
No. of poles	3	3	3/4	3				3/4				3				3/4				3				3/4				3/4			3/4				3/4			3/4	3/4
Rated ultimate short circuit breaking capacity 50/60Hz (kA rms) I_{cu}	380/415/500V	50	50	50	50	50	65	50	50	50	65	50	50	50	65	50	50	50	65	50	50	55	75	60	60	75	60	70	75	100	75	100	70	95	95				
	690V	-	-	-	-	-	35	50	-	-	35	50	-	-	35	50	-	-	35	50	-	-	40	65	-	40	65	-	Δ	65	85	65	85	Δ	Δ	Δ			
Rated service short circuit breaking capacity 50/60Hz (kA rms) I_{cs}	380/415/500V	50	50	50	50	50	65	50	50	50	65	50	50	50	65	50	50	50	65	50	50	55	75	60	60	75	60	70	75	100	75	100	70	95	95				
	690V	-	-	-	-	-	35	50	-	-	35	50	-	-	35	50	-	-	35	50	-	-	40	65	-	40	65	-	Δ	65	85	65	85	Δ	Δ	Δ			
Rated short time withstand capacity 50/60Hz (kA rms) I_{cw}	0.5 sec	50	50	50	50	50	65	50	50	50	65	50	50	50	65	50	50	50	65	50	50	55	75	60	60	75	60	70	75	100	75	100	70	95	95				
	1 sec	50	50	50	50	50	65	50	50	50	65	50	50	50	65	50	50	50	65	50	50	55	75	60	60	75	60	70	75	100	75	100	70	95	95				
	3 sec	-	-	25	-	25	35	50	-	25	35	50	-	25	35	50	-	35	35	50	-	45	50	65	50	55	65	55	Δ	70	85	70	85	70	Δ	Δ			
Rated making capacity 50/60Hz (kA peak) I_{cm}	380/415/500V	105	105	105	105	105	143	105	105	105	143	105	105	105	143	105	105	105	143	105	105	121	165	132	132	165	132	154	165	220	165	220	154	209	209				
	690V	-	-	-	-	-	73.5	105	-	-	73.5	105	-	-	73.5	105	-	-	73.5	105	-	-	84	143	-	84	143	-	Δ	143	187	143	187	Δ	Δ	Δ			
Rated impulse withstand voltage of main circuit (kV) U_{imp}	8	8	12	8				12				8				12				8				12			12				12			12	12				
Rated impulse withstand voltage of aux. circuit (kV) U_{imp}	4	4		4				4				4				4				4			4			4				4			4	4					
Typical opening time (ms)	40	40		40				40				40				40				40				40			40				40			40	40				
Typical closing time (ms)	60	60		60				60				60				60				60				60			60				60			60	60				
Utilization category	B	B		B				B				B				B				B				B			B				B			B	B				
Suitability for isolation	✓	✓		✓				✓				✓				✓				✓				✓			✓				✓			✓	✓				
Fixed	✓	✓	✓	✓	✓	✓	✓	✓	✓	✓	✓	✓	✓	✓	✓	✓	✓	✓	✓	✓	✓	x	✓	✓	x	✓	✓	x	✓	x	x	x	x	✓	x	x			
Draw out	x	x	✓	x	✓	✓	✓	x	✓	✓	✓	x	✓	✓	✓	x	✓	✓	✓	x	✓	✓	✓	✓	✓	✓	✓	✓	✓	✓	✓	✓	✓	✓	✓	✓	✓		
Manual	✓	✓	✓	✓	✓	✓	✓	✓	✓	✓	✓	✓	✓	✓	✓	✓	✓	✓	✓	✓	✓	✓	✓	✓	✓	✓	✓	✓	✓	✓	✓	✓	✓	✓	✓	✓	✓		
Electrical	x	x	✓	x	✓	✓	✓	x	✓	✓	✓	x	✓	✓	✓	x	✓	✓	✓	x	✓	✓	✓	✓	✓	✓	✓	✓	✓	✓	✓	✓	✓	✓	✓	✓	✓		
Electrical & Mechanical life (operating cycles) †	15000	15000	20000	15000				20000				15000				20000				15000				20000				10000			5000	10000	10000			5000	5000	5000	
Electrical life without maintenance	6000	6000	8000	6000	8000	8000	8000	6000	8000	8000	8000	6000	7000	7000	7000	6000	7000	7000	7000	4500	6000	6000	6000	5000	5000	5000	5000	2500	5000	5000	5000	5000	2500	2500	2500				
Dimensions (in mm)	Fixed	H	385	385	394	385	394		385	394			385	394			385	-	394		-	394			-	509			Δ	Δ		509	-	-					
		W	3 Pole	316	316	326	316	326		316	326			316	326			316	-	482		-	482			-	636			Δ	Δ		636	-	-				
			4 Pole	-	-	414	-	414		-	414			-	414			-	-	628		-	628			-	838			Δ	Δ		838	-	-				
		D	449	449	443	449	443	431		449	443	431		449	443	431		437	-	431		-	431			-	518			Δ	Δ		518	-	-				
Draw out	H	-	-	468	-	468		-	468			-	468			-	468		468	468			468	468			468	583			468	468		583	583	583			
	W	3 Pole	-	-	399	-	399		-	399			-	399			-	399		555	555			555	555			711	701		701	701		711	913	913			
		4 Pole	-	-	487	-	487		-	487			-	487			-	487		701	701			701	701			913	909		909	913		1182	1182				
	D	-	-	587	-	587		-	587			-	587			-	587		587	587			587	587			612	652		607	607		678	691	691				

* Please consult us for application at dc voltages & higher operational voltage upto 690V AC.
 # Available in Control Box version
 • Tolerance is +20ms

† Electrical life = Mechanical life. However, arcing contacts need to be replaced depending upon wear & tear.
 Δ Please consult us.

New H2 range has replaced old HO range

PROTECTION RELEASES

Thermo-magnetic Release Type - DN1

DN1 thermo-magnetic release offers reliable protection against overload, short-circuit and earth faults via multitap Cts. with ambient temperature compensation from -5°C to 50°C.

Protection

Overload Protection (Phase)

- Unique individual phase O/L setting adjustment helps to avoid the nuisance tripping of ACBs in unbalance load condition (due to single phase loads) on distribution transformer. Overload pick-up range: 0.75 to 1 times I_n

Short-Circuit Protection

- Two taps on CTs (working as rating plug) help in selecting operating threshold. Short-Circuit pickup range: 5.5 and 7.5 times I_n with minimum impulsion time of 25 ms to prevent nuisance tripping due to transients

Earth Fault Protection

- Offered with auxiliary earth fault release module. Earth-fault pick-up range: 0.2 to 0.5 times I_n



Microprocessor Based Release - SR18

Salient Features

- Self-powered & true RMS sensing
- Comprehensive protection
 - Overload (Phase), Instantaneous and Short-Circuit
- True Hot & Cold characteristics & switchable thermal memory
- Multi-state LED to indicate
 - Power ON condition
 - Test mode
- Individual fault annunciation through LEDs
- AN1 module for remote fault indication through LEDs with changeover contact for each kind of fault
- Provision for Self-diagnostic test (without tripping the breaker)
- Universal Test kit available for testing the release
- Conformance to EMI/EMC standards



Type of Protection	Setting Range	
	Pick-up Current	Time Delay
Overload (Phase)	I_r - 0.5 to 1.0 times I_n Steps : 0.50, 0.60, 0.65, 0.70, 0.75, 0.80, 0.85, 0.9, 0.95, 1	2.5 sec at 6 times I_r
Short-Circuit	2 to 10 times I_n Steps : 2, 3, 4, 5, 6, 7, 8, 9, 10	20 ms to 600 ms Steps: 20, 60, 100, 160, 200, 260, 300, 400, 500, 600 ms
Instantaneous	6 & 12 I_n	-

PROTECTION RELEASES

Microprocessor Based Release - SR18G

Salient Features

- Self –powered & True RMS sensing
- True Hot & Cold characteristics & switchable Thermal Memory
- Offers comprehensive protection against Overload - Phase & Neutral, Short-Circuit, Instantaneous, Earth Fault
- Settable Overload delay
- Settable Instantaneous setting with provision of “OFF”
- I^2t ON/OFF for Short-Circuit and Earth Fault protection
- Individual Fault LED indication
- Provision for Self-diagnostic test
- Conformance to EMI/EMC standards
- Testing through Universal Test kit



Type of Protection	Setting Range	
	Pick-up current	Time Delay
Overload (Phase)	I_r - 0.4 to 1.0 times I_n Steps : 0.40, 0.50, 0.60, 0.70, 0.75, 0.80, 0.85, 0.90, 0.95, 1	0.2 to 30 sec at 6 times I_r Steps : 0.2, 0.5, 1, 1.5, 2, 3.5, 6, 12, 17, 30 sec
Overload (Neutral)	I_n - 50% to 200% times I_r Steps : 50%, 100%, 150%, 200%	Same as Overload (Phase)
Short-Circuit	2 to 10 times I_n Steps : 2, 3, 4, 5, 6, 7, 8, 9, 10	I^2t ON = 0.02, 0.1, 0.2, 0.3, 0.4 sec I^2t OFF = 0.02, 0.1, 0.2, 0.3, 0.4, sec
Instantaneous	2 to 16 times I_n Steps : 2, 3, 4, 6, 8, 10, 12, 14, 16, OFF	-
Earth fault*	0.2 to 0.6 times I_n Steps : 0.2, 0.3, 0.4, 0.5, 0.6	I^2t ON = 0.1, 0.2, 0.3, 0.4 sec I^2t OFF = 0.1, 0.2, 0.3, 0.4, 1 sec

*In 3 phase, 4 wire system, Neutral CT is required for earth fault protection

PROTECTION RELEASES

Microprocessor Based Release - SR18G with display

Salient Features

- Self –powered & True RMS sensing
- True Hot & Cold characteristics & switchable Thermal Memory
- Unique 3 line O-LED display (Organic LED)
- Offers comprehensive protection against Overload - Phase & Neutral, Short-Circuit, Instantaneous, Earth Fault
- Settable Overload delay
- Settable Instantaneous setting with provision of “OFF”
- I^2t ON/OFF for Short-Circuit and Earth Fault protection
- Individual Fault LED indication
- Provision for Self-diagnostic test
- Conformance to EMI/EMC standards
- Testing through Universal Test kit
- Separate version with Zone Selective Interlocking (ZSI) - SR18Gi with display



Type of Protection	Setting Range	
	Pick-up current	Time Delay
Overload (Phase)	I_r - 0.5 to 1.0 times I_n Steps : 0.50, 0.60, 0.65, 0.70, 0.75, 0.80, 0.85, 0.90, 0.95, 1	0.2 to 30 sec at 6 times I_r Steps : 0.2, 0.5, 1, 1.5, 2, 3.5, 6, 12, 17, 30 sec
Overload (Neutral)	I_N -50% to 200% times I_r Steps : 50%, 100%, 150%, 200%	Same as Overload (Phase)
Short-Circuit	2 to 10 times I_n Steps : 2, 3, 4, 5, 6, 7, 8, 9, 10	I^2t ON = 0.02, 0.1, 0.2, 0.3, 0.4 sec I^2t OFF = 0.02, 0.1, 0.2, 0.3, 0.4, sec
Instantaneous	2 to 16 times I_n Steps : 2, 3, 4, 6, 8, 10, 12, 14, 16, OFF	-
Earth fault*	0.2 to 0.6 times I_n Steps : 0.2, 0.3, 0.4, 0.5, 0.6	I^2t ON = 0.1, 0.2, 0.3, 0.4 sec I^2t OFF = 0.1, 0.2, 0.3, 0.4, 1 sec

*In 3 phase, 4 wire system, Neutral CT is required for earth fault protection

Universal Test Kit

Salient Features

- Compatible with following E&A Protection Releases:
 - SR protection releases of C-Power ACB family
 - UNRS protection releases of U-Power ACB family
 - MTX and RC releases of D-Sine MCCB family
- Operates from 240V AC supply & generates single-phase voltage test signals
- Tests the release for
 - Phase fault i.e. for overload, short-circuit, instantaneous and Earth Fault protection
- ACB test current multiples
 - For O/L, S/C and Inst - 2.5 I_n to 13 I_n in steps of 0.05
 - For E/F - 0.25 I_n to 0.70 I_n in steps of 0.05
- MCCB test current multiples
 - For O/L – 2 I_n , 4 I_n , 6 I_n and 8 I_n
 - For S/C and Inst - 2.5 I_n to 13 I_n in steps of 0.05
 - For E/F - 0.25 I_n to 0.70 I_n in steps of 0.05
- LCD display indicated the trip time (three places after decimal)



PROTECTION RELEASES

Microprocessor-based, Communication-capable Release - SR71

Salient Features

- True RMS sensing
- Offers comprehensive protection for overload, short-circuit, instantaneous, earth fault and neutral overload
- High resolution backlit LCD display
- Intelligent Pre-trip alarm to prevent system shutdown
- Password protected settings and commands
- MODBUS RTU protocol with intrinsic RS 485 port
- LED indication for POWER ON, different faults and Pre-trip alarm
- 2 sets of storable protection settings
- Last 5 trips & 128 Event records with time & date stamping
- 3 programmable contacts-1 for micro controller failure, 2 for basic fault annunciation
- 4 relay contacts for indication of exceeding maximum demand, Pre-trip alarm and control on breaker (closing and opening)
- Rating-plug for precise protection at lower load currents
- Auto-doubling features to prevent nuisance tripping
- Selectable I^2t based current for short-time and earth fault zones
- Thermal reflectivity enables faster tripping on recurrent overloads
- Inbuilt Zone Selective Interlocking
- Provision for Self-diagnostic test
- Conformance to EMI/EMC standards



Parameter		Screen Abbreviation	Details	Factory Settings	
Overload (Phase)	Current Settings (A), $I_r = I_n \times \dots$	PICK-UP	0.4 to 1.0 I_n in steps of 0.05 I_n	1.0 I_n	
	Time Delay, T_r (sec) at $6 \times I_r$	TMS-Tr	0.5-1-2-4-6-12-18-24-30	30 sec	
	Pre-trip Alarm Settings	PREALAR	0.5 to 0.95 I_r in steps of 0.05 I_r	0.95 I_r	
	Thermal Reflectivity	THM-MEM	ON / OFF	OFF	
	Function	FUNC	Enable / Disable		
Neutral Fault	Current Settings (A), $I_n = I_r \times \dots$	PICK-UP	0.5-1.0	1.0 I_r	
	Time Delay (sec)	DELAY	Same as 'Overload (Phase)'	30 sec	
Short-Circuit	Current Settings (A), $I_{sd} = I_n \times \dots$	PICK-UP	2 to 10 I_n in steps of 0.5 I_n	10 I_n	
	Time Delay, t_{sd} (msec) at $10 \times I_n$	I^2t OFF	DELAY	20-100-200-300-400	400 msec
		I^2t ON	DELAY	20-100-200-300-400	400 msec
	Pre-trip Alarm Settings	PREALAR	0.5 to 0.95 I_s in steps of 0.05 I_s	0.95 I_s	
	I^2t	I^2t	ON / OFF		
	Cold-load Pick-up	COLDPIC	Enable / Disable	Disable	
Instantaneous	Cold-load Pick-up Delay	CP-DLY	0.1 to 10 sec in steps of 0.1 sec	0.1 sec	
	Function	FUNC	Enable / Disable	Enable	
Earth Fault	Current Settings (A), $I_i = I_n \times \dots$	PICK-UP	2 to 16 I_n in steps of 0.1 I_n	16 I_n	
	Function	FUNC	Enable / Disable	Enable	
			Current Settings (A), $I_g = I_n \times \dots$	PICK-UP	0.1 to 0.6 in steps of 0.05 I_n for I^2t ON 0.1 to 0.6 in steps of 0.01 I_n for I^2t OFF
	Time Delay (sec), t_g	DELAY	100 to 400 msec in steps of 100 msec for I^2t ON	3 sec	
			0.1 to 5 sec in steps of 100 msec for I^2t OFF		
	Pre-trip Alarm Settings	PREALAR	0.5 to 0.95 I_g in steps of 0.05 I_g	0.95 I_g	
I^2t	I^2t	ON / OFF	OFF		
Cold-load Pick-up	COLDPIC	Enable / Disable	Disable		

Note: Both Protection Groups 1 & 2 carry the same factory settings.

ADDITIONAL PROTECTIONS

Parameter		Screen Abbreviation	Details	Factory Settings
Under Current	Function	FUNC	Enable / Disable	Disable
	Current Setting (A) x In	PICK-UP	15% to 80% in steps of 5% In	0.8 In
	Time Delay (secs)	DELAY	1 to 255 in steps of 1 second	1 second
	Trip / Alarm	MODE	Either / Both	Alarm
Current Unbalance	Function	FUNC	Enable / Disable	Disable
	Current Setting (A) x In	PICKUP	10% to 95% in steps of 5% In	0.2 In
	Time Delay (secs)	DELAY	1 to 10 in steps of 5 secs	2.0 secs
Over Voltage #	Function	FUNC	Enable / Disable	Disable
	Voltage Setting (V) Vs = Vn x ..	PICK-UP	105% to 150% in steps of 5% Vn	1.2 Vn
	Time Delay (secs)	DELAY	0.1 to 100 in steps of 0.1 secs	5.0 secs
	Reset Voltage	RSTSET	85% to 98% in steps of 1% Vs	0.95 Vs
	Trip / Alarm	MODE	Either / Both	Alarm
Under Voltage #	Function	FUNC	Enable / Disable	Disable
	Voltage Setting (V) Vn x ..	PICK-UP	45% to 65% in steps of 5% Vn	0.6 Vn
	Time Delay (secs)	DELAY	0.1 to 5 in steps of 0.1 secs	1 second
	Reset Voltage	RSTSET	102% to 115% in steps of 1% Vs	1.02 Vs
	Trip / Alarm	MODE	Either / Both	Alarm
Under Frequency #	Function	FUNC	Enable / Disable	Disable
	Frequency Setting (Hz)	PICK-UP	45 to 50Hz for 50Hz in steps of 0.01Hz	48.0Hz
			57 to 60Hz for 60Hz in steps of 0.01Hz	59.0Hz
	Time Delay (secs)	DELAY	0.1 to 100 secs in steps of 0.1 Second	0.2 secs
	Drop Off Frequency	DRPOFF	0.02 to 0.10Hz in steps of 0.1Hz	0.1Hz
Trip / Alarm	MODE	Either / Both	Alarm	
Over Frequency #	Function	FUNC	Enable / Disable	Disable
	Frequency Setting (Hz)	PICK-UP	50 to 55Hz for 50Hz in steps of 0.01Hz	52.0Hz
			60 to 62Hz for 60Hz in steps of 0.01Hz	61.0Hz
	Time Delay (secs)	DELAY	0.1 to 100 secs in steps of 0.1 second	0.2 secs
	Drop Off Frequency	DRPOFF	0.02 to 0.10Hz in steps of 0.1Hz	0.1Hz
Trip / Alarm	MODE	Either / Both	Alarm	
Reverse Power #	Function	FUNC	Enable / Disable	Disable
	Settings (kW)	PICK-UP	0.02 to 0.4 in steps of 0.01 Pn	0.2 Pn
	Time Delay (secs)	DELAY	1 to 100 in steps of 0.1 secs	2.0 secs
	Trip Alarm	MODE	Either / Both	Alarm
Phase Sequence #	Function	FUNC	Enable / Disable	Disable
	Settings	PICK-UP	123 - 132	123
	Time Delay (secs)	DELAY	0 to 5 in steps of 0.5 secs	2 secs
	Trip / Alarm	MODE	Either / Both	Alarm
Breaker Failure	Function	FUNC	Enable / Disable	Disable
	Time Delay (secs)	DELAY	0.05 to 2 secs in steps of 0.01 secs	1.0 second
Maximum Demand Exceed	Function	FUNC	Enable / Disable	Disable
	Settings (kW)	PICK-UP	40 kW - 1600 kW	100 kW
	Step	DELAY	10 kW - 1000 kW	10 kW
<i>i</i> - Discrimination		<i>i</i> -Discrimination	Enable / Disable	Disable

Requires SR71-PM module

METERING

Parameter	Screen Abbreviation	Details
Current	I	Phase, Earth and Neutral
	I _{max}	Maximum running Current per Phase
	%Load	Percent Loading
Voltage#	V	Phase-Neutral
	V _{ph-Vph}	Phase-Phase
Frequency #	F	System Frequency
Power Factor #	PF	System Power Factor
Power #	kW	Active Power per Phase and Total (kW)
	kVA _r	Reactive Power per Phase and Total (kVA _r)
	kVA	Apparent Power per Phase and Total (kVA)
	kW	Maximum Demand (kW)
Energy #	kWh	Total Active Energy (kWh)
	kVA _r h	Total Reactive Energy (kVA _r h)
	kVAh	Total Apparent Energy (kVAh)
Harmonic-Current	I1HAR	R-Phase Current Harmonics
	I2HAR	Y-Phase Current Harmonics
	I3HAR	B-Phase Current Harmonics
Harmonic-Voltage #	V1HAR	R-Phase Voltage Harmonics
	V2HAR	Y-Phase Voltage Harmonics
	V3HAR	B-Phase Voltage Harmonics
Display		High Resolution Backlit LCD

Requires SR71-PM module

ADDITIONAL FEATURES

Parameter	Screen Abbreviation	Details
LED Indications	Auxiliary Power ON	✓
	Overload	✓
	Short-Circuit	✓
	Instantaneous	✓
	Earth Fault	✓
	Neutral Fault	✓
	Trip	✓
	Alarm	✓
Auxiliary Supply		24V DC
Digital Inputs		4 Nos.
Output Relays		3 Internal + 4 External Relays
		240V AC / 5A, 30V DC / 5A (resistive load)
Rating Plug	In Multiplier	630-800-1000-1250-2000-3200-5000
Communication	Protocol	MODBUS RTU
	Link used	RS 485
Maintenance Indication		I ² t based
Event Records (128)		Pick-up, Alarm, Trip, Date, Time and Cause of Event, voltage and current readings in all phases
Trip Records		Last 5 records with date and time stamping,
Testing	Self-Diagnostic Test	✓
Supplementary Modules	Communication Module (SR71-COM)	MODBUS RTU using RS 485
	Power Supply Module (UN-PS)	Input : 26V to 60V DC, 90 to 300V AC/DC Output : 24V DC
	Power Metering Module (SR71-PM)	240V AC, 415V AC
	Relay Module (SR71-REL)	4 Relay Outputs (Breaker OPEN, Breaker CLOSE, Pre Trip alarm and MD Exceed)
No. of Storable Settings		2

PROTECTION CHARACTERISTIC

Time-current (DN1)

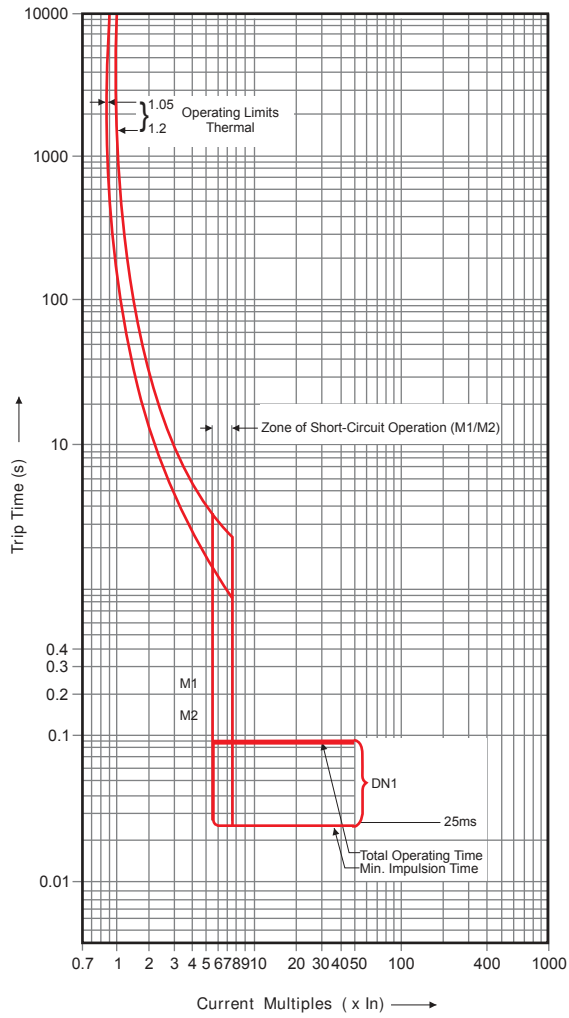

Overload (SR18)

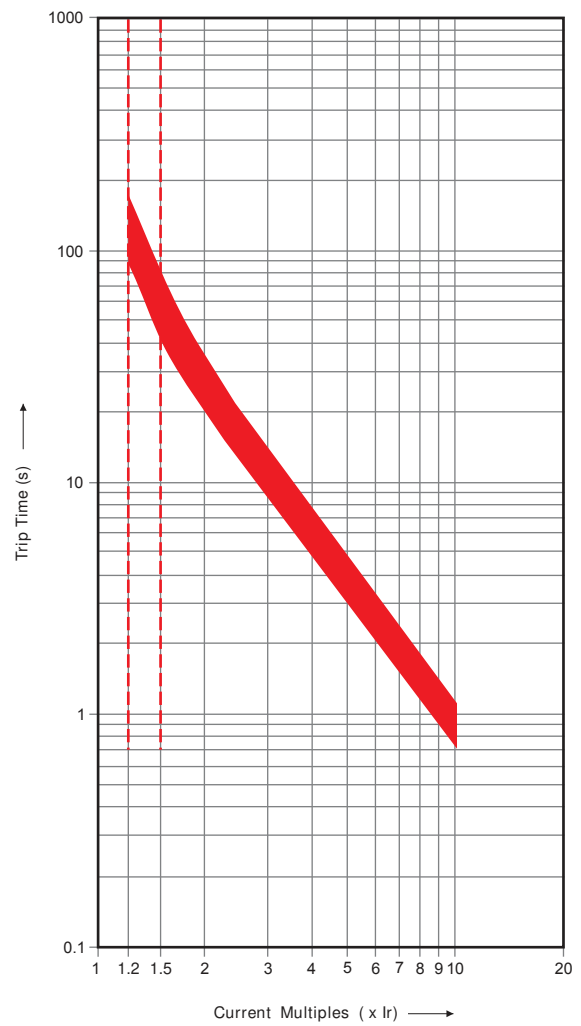

PROTECTION CHARACTERISTIC

Short-Circuit
(SR18)

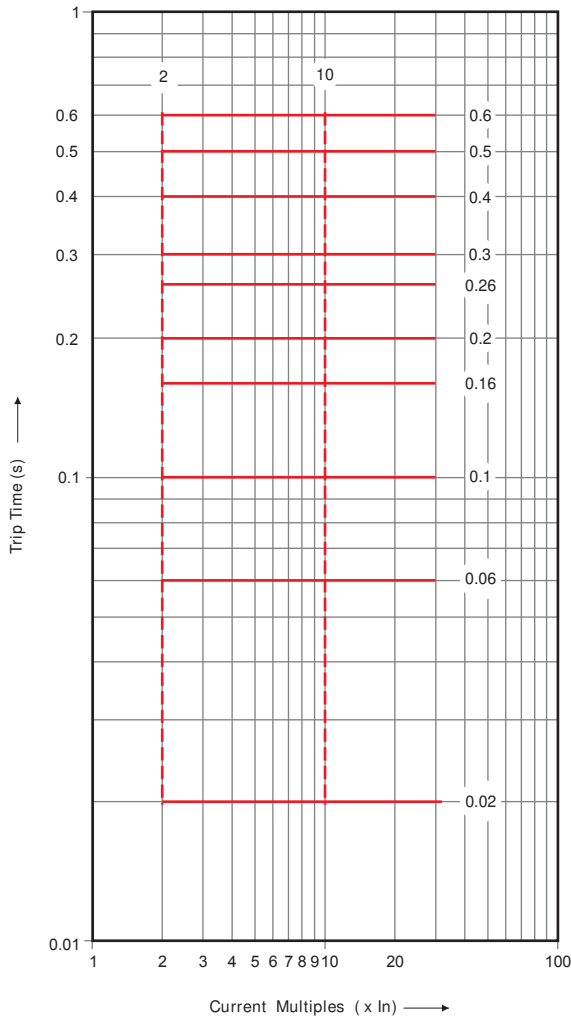

Overload
(SR18G, SR18G/SR18Gi with display)

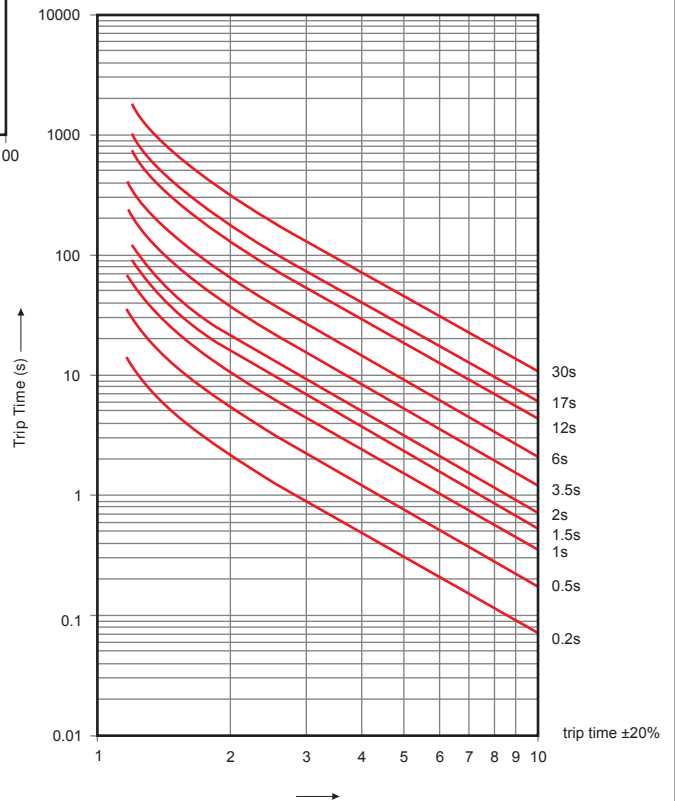

PROTECTION CHARACTERISTIC

Short-Circuit I^2t ON
(SR18G, SR18G/SR18Gi with display)

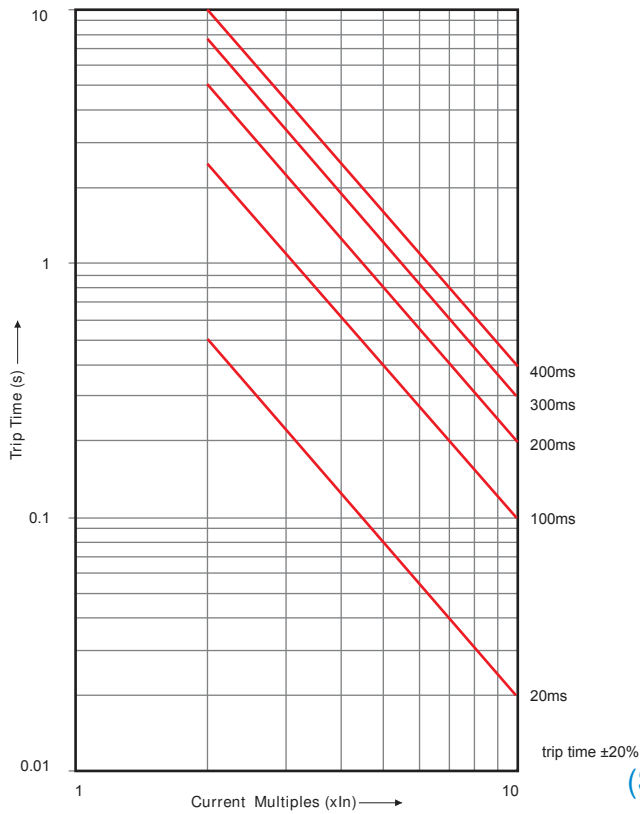

Short-Circuit I^2t OFF
(SR18G, SR18G/SR18Gi with display)

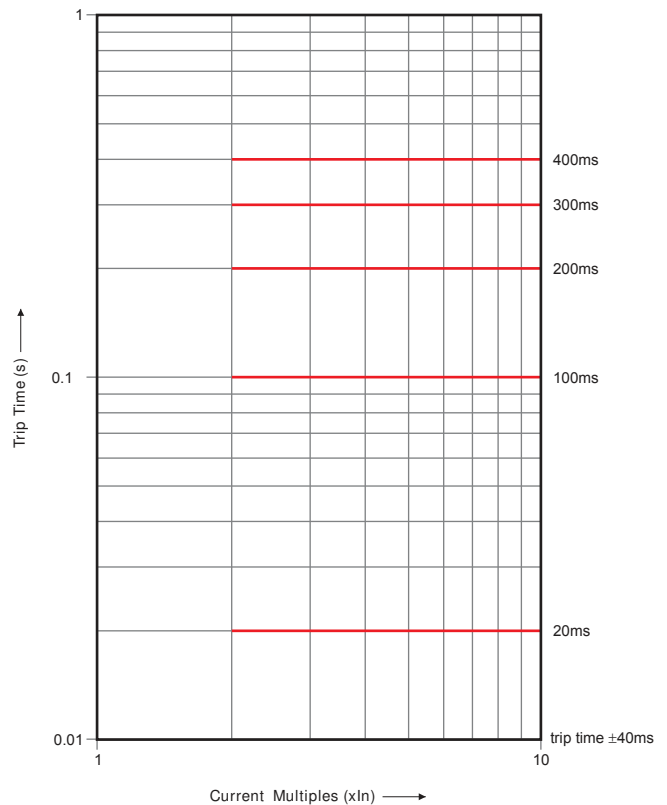

PROTECTION CHARACTERISTIC

Instantaneous
(SR18G, SR18G/SR18Gi with display)

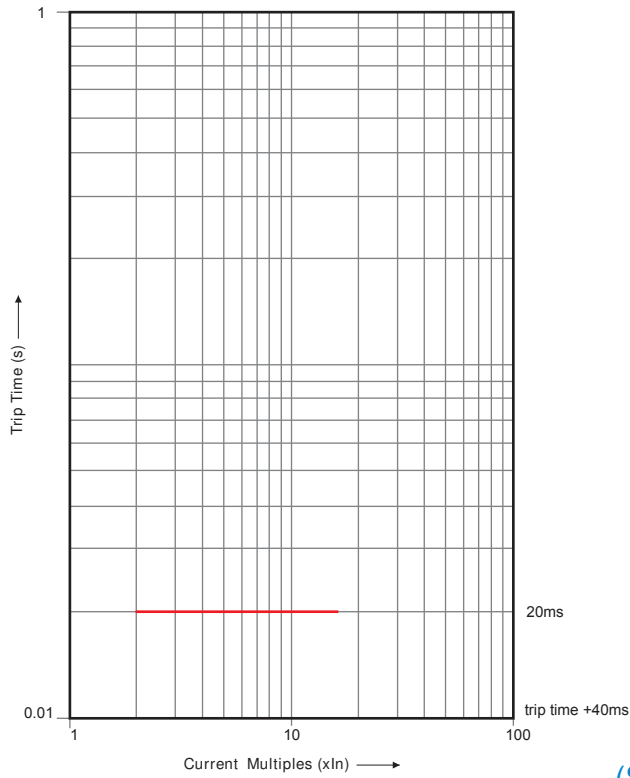

Earth Fault I_t²t ON
(SR18G, SR18G/SR18Gi with display)

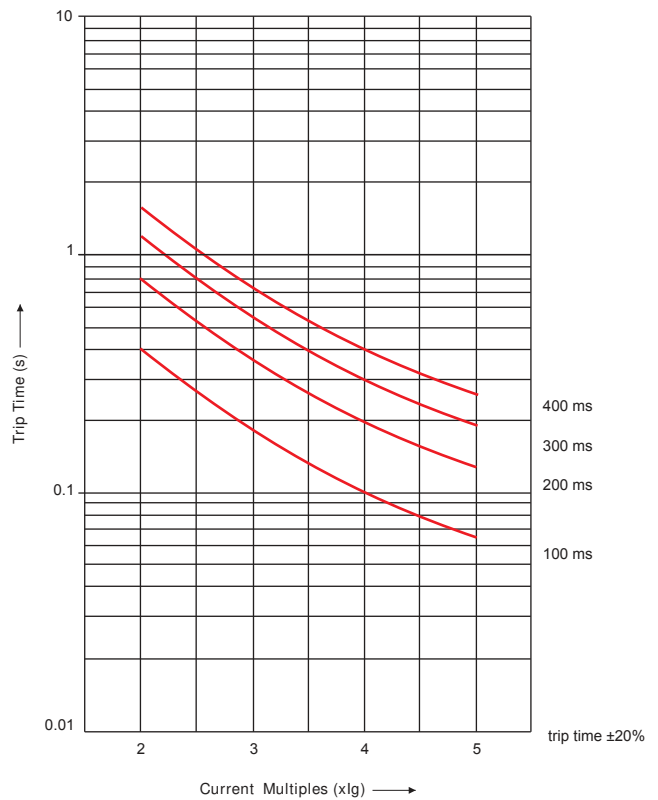

PROTECTION CHARACTERISTIC

Earth Fault I_t OFF
(SR18G, SR18G/SR18Gi with display)

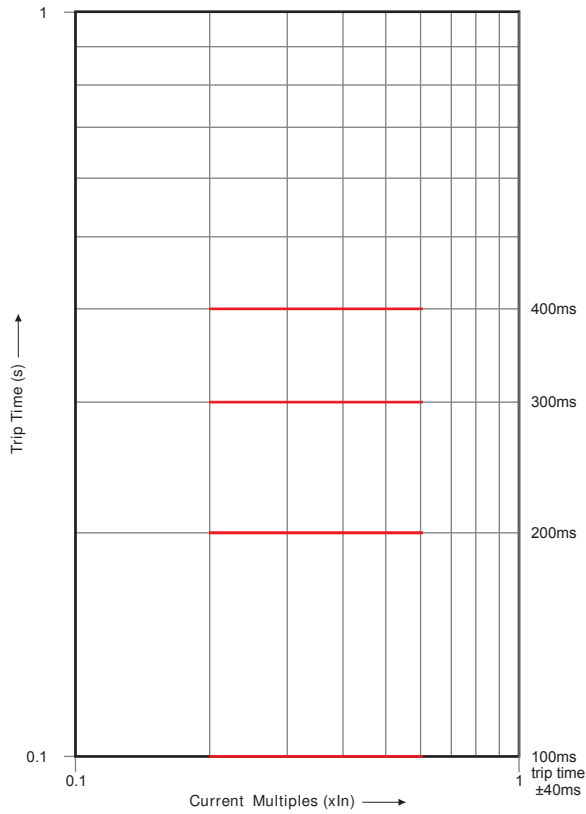

Overload Curve
(SR71)

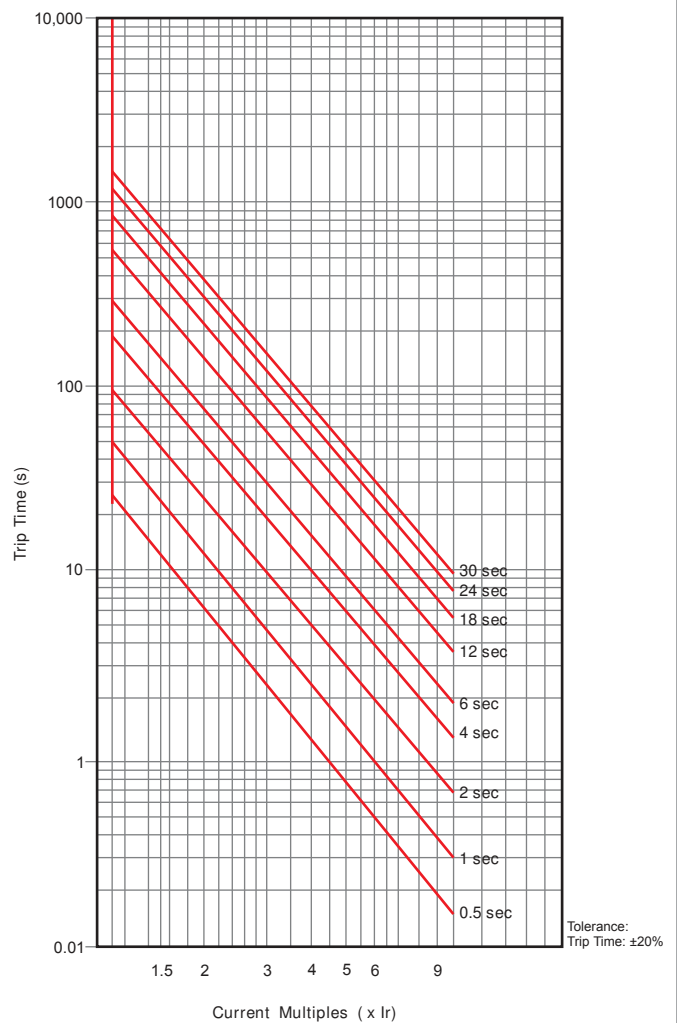

PROTECTION CHARACTERISTIC

Short-Circuit - I^2t ON
(SR71)

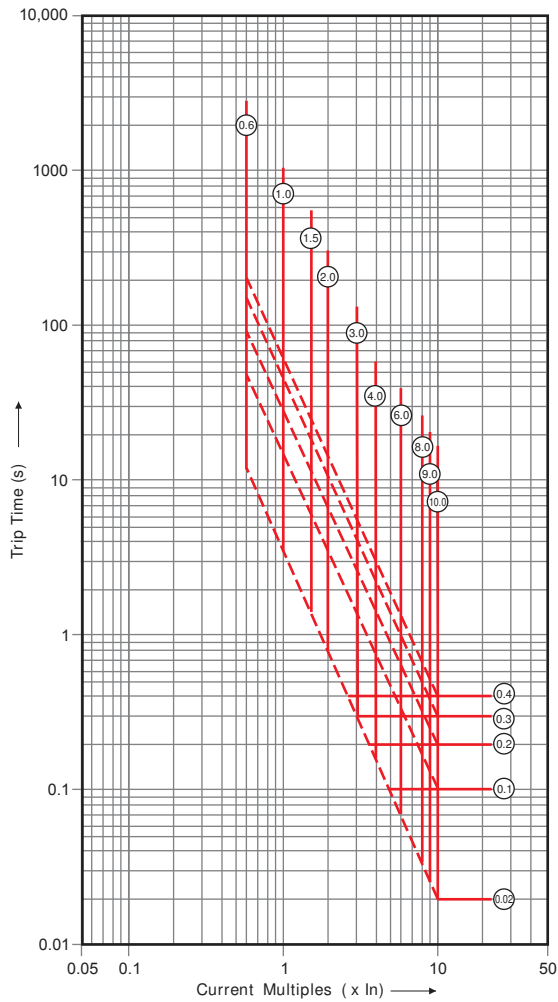

Short-Circuit - I^2t OFF
(SR71)

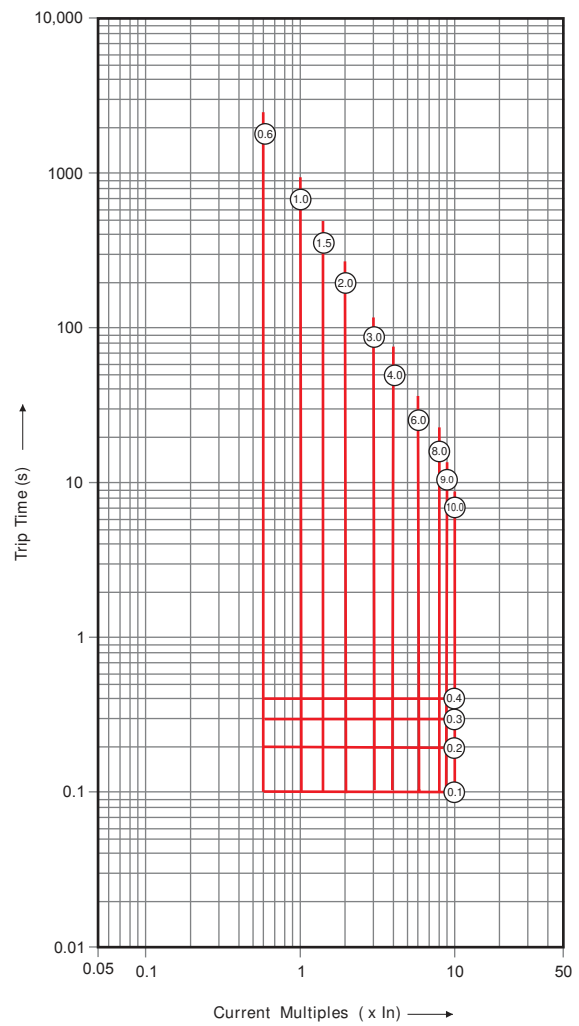

PROTECTION CHARACTERISTIC

Instantaneous
(SR71)

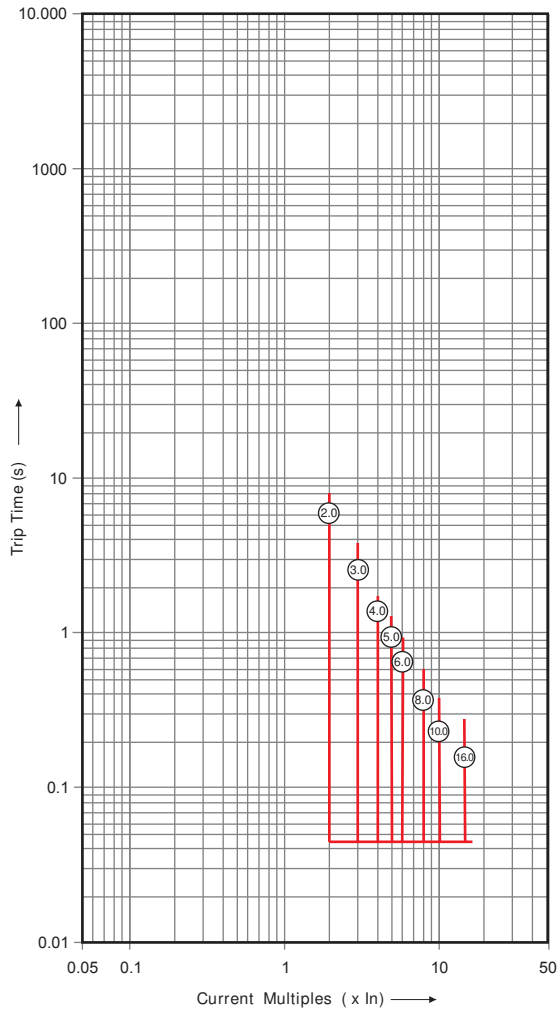

Earth Fault - I_t ON
(SR71)

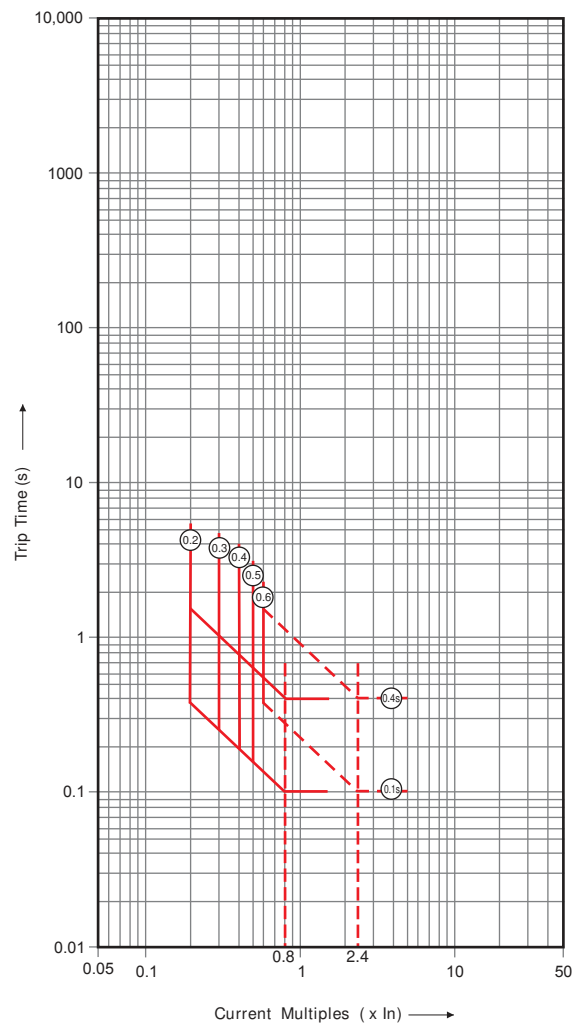

PROTECTION CHARACTERISTIC

Earth Fault - I²t OFF
(SR71)

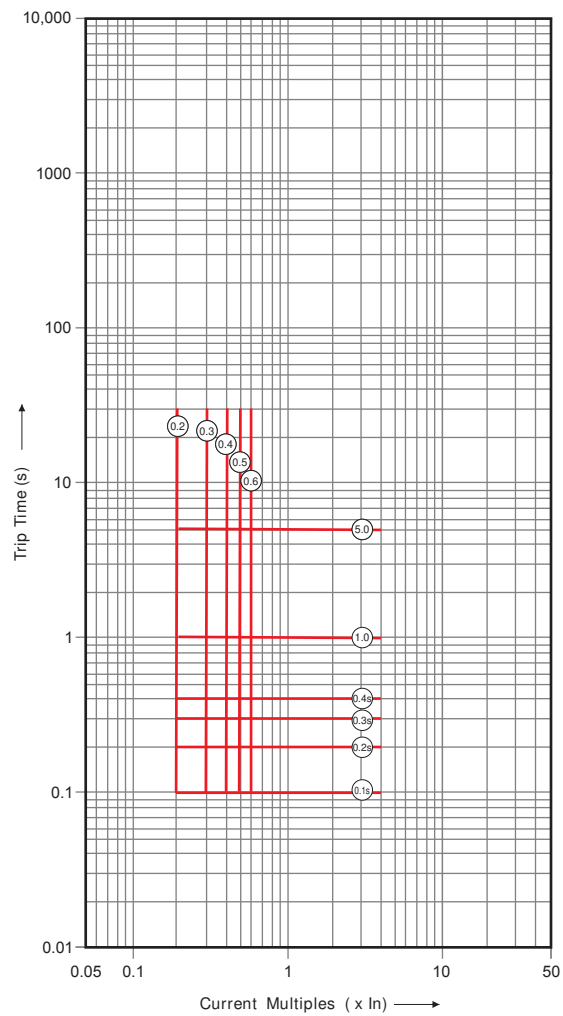

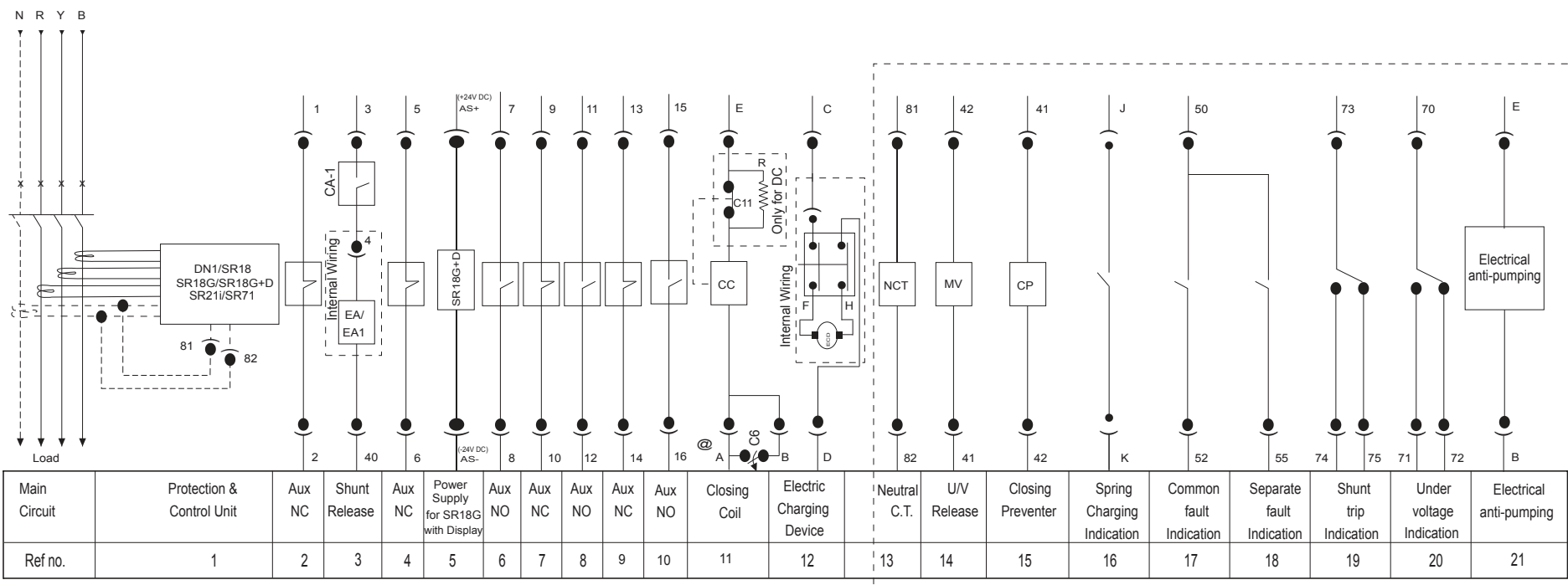

As per order/requirement

The above drawing is for EDO breakers.

1) For MDO/MF versions

Ref no. 3, 10, 11 are not applicable

E, B, C, D, A, 15 are applicable only in electrical breakers.

2) For EF versions

The ref. no. 12, 13, 14, 15, 16, 17, 18, 19, 20, 21 are provided as per customer requirement.

3) When using AN1 Annunciator Module with SR18G/18Gi (with display releases)

A) AS+ & AS- always appear after 5,6 nos. of the SIC.

B) If 1,2,3,4,5,6 nos. of SICs are not there, AS+ & AS- will appear first.

C) SIC 13 and 14 Nos. are not offered in 3P EDO and 3P MDO standard breakers.

FCA Limit switch(Shown in breaker reset condition)

R Economy Resistor

C11 Limit switch operates when closing electromagnet is held on

C6 'Service' position microswitch for withdrawable circuit breakers (shown in 'test' position)

For SR18Gi+D & SR21i release (P&C unit)

SI, SO → i discrimination → Short circuit i/p & o/p

GI, GO → i discrimination → Earth fault i/p & o/p

G → Earth





ACCESSORIES

Type	Data
<p>Lockable Trip Push Button (LTPB)</p> 	<p>Mounted in place of normal trip push button. With this, ACB can be locked in trip condition. For interlocking, LTPBs are offered in the following combinations:</p> <ul style="list-style-type: none"> • 4 different types of keys i.e. AA, BB, CC and DD suitable for 2 I/C & 1 B/C schemes • Combination of L, M, N, LM and MN locks, which are suitable for 3 I/C & 2 B/C schemes • Combination of K, L, M, N, KL, LM and MN locks, which are suitable for 4 I/C & 3 B/C schemes • Combination of J, K, L, M, N, JK, KL, LM and MN locks, which are suitable for 5 I/C & 4 B/C schemes
<p>View of the Cradle</p>  <p>Door Interlock Racking Interlock Locking in 'Isolated' Position</p>	<p>Locking in Isolated Position (LIP) The facility of locking the ACB in Isolated position is available in Drawout ACBs. This is useful to achieve interlocking between Main & Standby source. Similar lock is available as LOCK IN ANY POSITION.</p> <p>Door Interlock This ensures:</p> <ul style="list-style-type: none"> • Unless the panel door is closed, breaker cannot be racked in or out • Unless the breaker is in Isolated Position, it is not possible to open the panel door <p>Racking Interlock This ensures that breaker cannot be racked in/out unless the ACB is in tripped/open condition.</p>
<p>Mechanical Interlock</p> 	<p>It is possible to provide "Mechanical Interlock" between two breakers of the same or different ratings in vertical or horizontal configurations. Mechanical interlock is available for ACBs upto 4000A by flexible cables of 2 metres.</p>

ACCESSORIES

Type	Data
 <p>A photograph showing a micro-switch component labeled C1 with a red arrow pointing to it. The component is mounted on a printed circuit board (PCB) within a metal enclosure.</p>	<p>Common indication of tripping due to overload, short-circuit and earth faults.</p> <ul style="list-style-type: none"> • Provided by micro-switch C1 fitted inside the ACB • Available as an option in all releases
 <p>A photograph showing a micro-switch component labeled C2 with a red arrow pointing to it. The component is mounted on a PCB inside a metal enclosure.</p>	<p>Separate indication of tripping due to overload, short-circuit and earth faults.</p> <ul style="list-style-type: none"> • For release type DN1, this is provided by micro-switch C1 & C2 (C2 fitted inside release)
<p>AN1-Annunciator Module</p>  <p>A photograph of the AN1-Annunciator Module, a rectangular metal enclosure with a front panel featuring three LEDs and a contact.</p>	<p>Remote indication of tripping due to overload, short-circuit and earth faults.</p> <ul style="list-style-type: none"> • Can be used with releases type SR18/SR18G/SR21i/SR18G & SR18Gi with display • Individual fault indication provided by three separate LEDs for <ul style="list-style-type: none"> - Long time faults - Short time fault/instantaneous fault - Earth fault - One potential free contact rated 5A at 230V AC available for each type of fault • Flush mounting on panel (H-W-D=92mm x 46mm x 105mm) • Operating voltage: 240V AC
 <p>A photograph showing a micro-switch component labeled C5 with a red arrow pointing to it. The component is mounted on a PCB.</p>	<p>Indication for operation of shunt release or undervoltage release.</p> <ul style="list-style-type: none"> • Provided by micro-switch C5 fitted on the shunt release or undervoltage release

ACCESSORIES

Type	Data	Technical Data													
<p>Shunt Release</p> 	<ul style="list-style-type: none"> For remote tripping of the breaker Shunt release coil is short time rated and is disconnected from the circuit by an auxiliary contact when the ACB trips (Refer to wiring diagram) Low power consumption Two types available: <ul style="list-style-type: none"> EA for DC application EA1 for AC application 	<table border="1"> <thead> <tr> <th>Type of Release</th> <th>Nominal Voltage Use (V)</th> <th>Power consumption at pick-up</th> <th>Operation Limit</th> </tr> </thead> <tbody> <tr> <td>EA1</td> <td>110 AC 240 AC 415 AC</td> <td>800 VA 800 VA 800 VA</td> <td>10-130% V</td> </tr> <tr> <td>EA</td> <td>24V DC 48V DC 110 DC 220 DC</td> <td>32 W 125 W 45 W 30 W</td> <td>65-130% V</td> </tr> </tbody> </table> <p>Note : Other voltages available on request</p>	Type of Release	Nominal Voltage Use (V)	Power consumption at pick-up	Operation Limit	EA1	110 AC 240 AC 415 AC	800 VA 800 VA 800 VA	10-130% V	EA	24V DC 48V DC 110 DC 220 DC	32 W 125 W 45 W 30 W	65-130% V	
Type of Release	Nominal Voltage Use (V)	Power consumption at pick-up	Operation Limit												
EA1	110 AC 240 AC 415 AC	800 VA 800 VA 800 VA	10-130% V												
EA	24V DC 48V DC 110 DC 220 DC	32 W 125 W 45 W 30 W	65-130% V												
<p>Under Voltage Release</p> 	<ul style="list-style-type: none"> Type MV With no intentional time delay <p>Notes: When under voltage release is provided, the ACB can be closed only when supply is available to the under voltage release.</p>	<table border="1"> <thead> <tr> <th>Parameter</th> <th>Specification</th> </tr> </thead> <tbody> <tr> <td>Nominal voltage</td> <td>240V & 415V 50Hz AC, 220V & 415V 60Hz AC, & 24V DC</td> </tr> <tr> <td>Pick up (V)</td> <td>80% Ue</td> </tr> <tr> <td>Drop off (V)</td> <td>35-65% Ue</td> </tr> <tr> <td>VA Consumption</td> <td>Pick up - 23 VA Hold on - 8.5 VA</td> </tr> <tr> <td>Watt loss</td> <td>6 W</td> </tr> </tbody> </table>	Parameter	Specification	Nominal voltage	240V & 415V 50Hz AC, 220V & 415V 60Hz AC, & 24V DC	Pick up (V)	80% Ue	Drop off (V)	35-65% Ue	VA Consumption	Pick up - 23 VA Hold on - 8.5 VA	Watt loss	6 W	
Parameter	Specification														
Nominal voltage	240V & 415V 50Hz AC, 220V & 415V 60Hz AC, & 24V DC														
Pick up (V)	80% Ue														
Drop off (V)	35-65% Ue														
VA Consumption	Pick up - 23 VA Hold on - 8.5 VA														
Watt loss	6 W														
<p>Closing Release</p> 	<p>Closing release remotely closes the circuit breaker if the mechanism spring is already charged.</p>	<table border="1"> <thead> <tr> <th rowspan="2">Rated voltage (Us)</th> <th colspan="2">Power consumption</th> <th rowspan="2">Range of operation</th> </tr> <tr> <th>Pick-up</th> <th>Hold-on</th> </tr> </thead> <tbody> <tr> <td>110V, 50Hz 240V, 50Hz 220V, 60Hz</td> <td>320 VA</td> <td>50 VA</td> <td rowspan="2">85-110% Us</td> </tr> <tr> <td>110V DC, 220V DC 24V, 30V, 48V DC</td> <td>300 W</td> <td>50 W</td> </tr> </tbody> </table>	Rated voltage (Us)	Power consumption		Range of operation	Pick-up	Hold-on	110V, 50Hz 240V, 50Hz 220V, 60Hz	320 VA	50 VA	85-110% Us	110V DC, 220V DC 24V, 30V, 48V DC	300 W	50 W
Rated voltage (Us)	Power consumption			Range of operation											
	Pick-up	Hold-on													
110V, 50Hz 240V, 50Hz 220V, 60Hz	320 VA	50 VA	85-110% Us												
110V DC, 220V DC 24V, 30V, 48V DC	300 W	50 W													
<p>Spring Charging Motor</p> 	<p>Electrical charging device automatically charges the mechanism spring of the circuit-breaker. After circuit-breaker closing, the geared motor immediately recharges the closing spring. Thus instantaneous reclosing of the circuit-breaker is possible following opening operation.</p>	<table border="1"> <thead> <tr> <th>Rated operational voltage (Ue)</th> <th>Power consumption</th> <th>Range of operation</th> </tr> </thead> <tbody> <tr> <td>240V AC</td> <td>320 VA</td> <td rowspan="2">85-110% Ue</td> </tr> <tr> <td>110V DC 220V DC</td> <td>154 W</td> </tr> </tbody> </table>	Rated operational voltage (Ue)	Power consumption	Range of operation	240V AC	320 VA	85-110% Ue	110V DC 220V DC	154 W					
Rated operational voltage (Ue)	Power consumption	Range of operation													
240V AC	320 VA	85-110% Ue													
110V DC 220V DC	154 W														
<p>Auxiliary Contacts</p> 	<p>Two combinations available:</p> <ul style="list-style-type: none"> 2 NO + 2 NC 6 NO + 6 NC 	<table border="1"> <thead> <tr> <th>Electrical circuit</th> <th>Voltage (V)</th> <th>Rated current (A)</th> </tr> </thead> <tbody> <tr> <td>Resistive</td> <td>24 to 415 AC 250V DC</td> <td>16 1.2</td> </tr> <tr> <td>Non-resistive</td> <td>24 to 415 AC 250V DC</td> <td>16 1.0 #</td> </tr> </tbody> </table> <p># L/R = 15 ms with 2NO or 2NC contacts in series</p>	Electrical circuit	Voltage (V)	Rated current (A)	Resistive	24 to 415 AC 250V DC	16 1.2	Non-resistive	24 to 415 AC 250V DC	16 1.0 #				
Electrical circuit	Voltage (V)	Rated current (A)													
Resistive	24 to 415 AC 250V DC	16 1.2													
Non-resistive	24 to 415 AC 250V DC	16 1.0 #													

OVERALL DIMENSIONS

Fixed Breakers

For 800A to 2500A 3P/4P C/H & 400A to 1600A 3P/4P S1

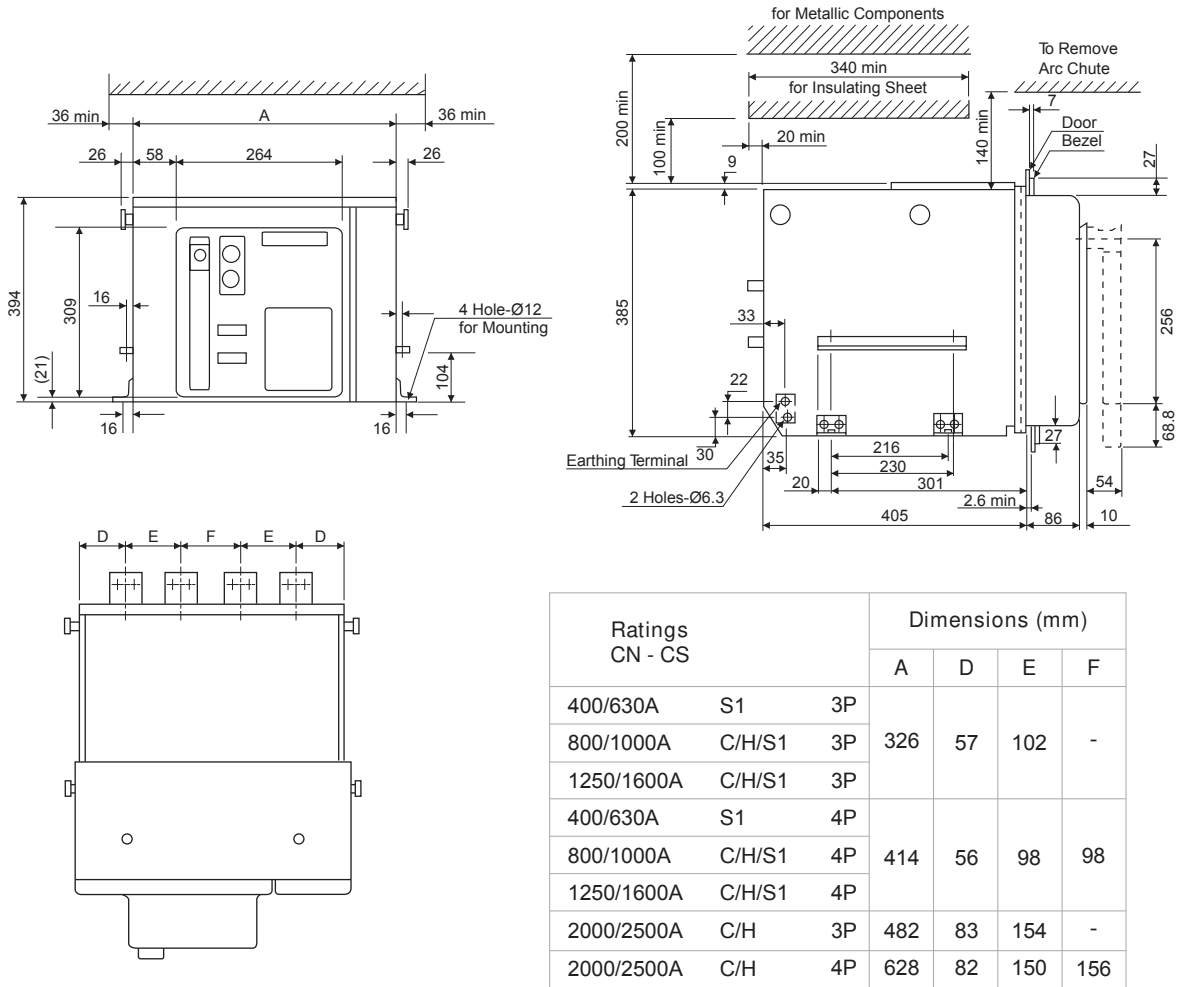

For CN-CS...E 400A-2000A 3P

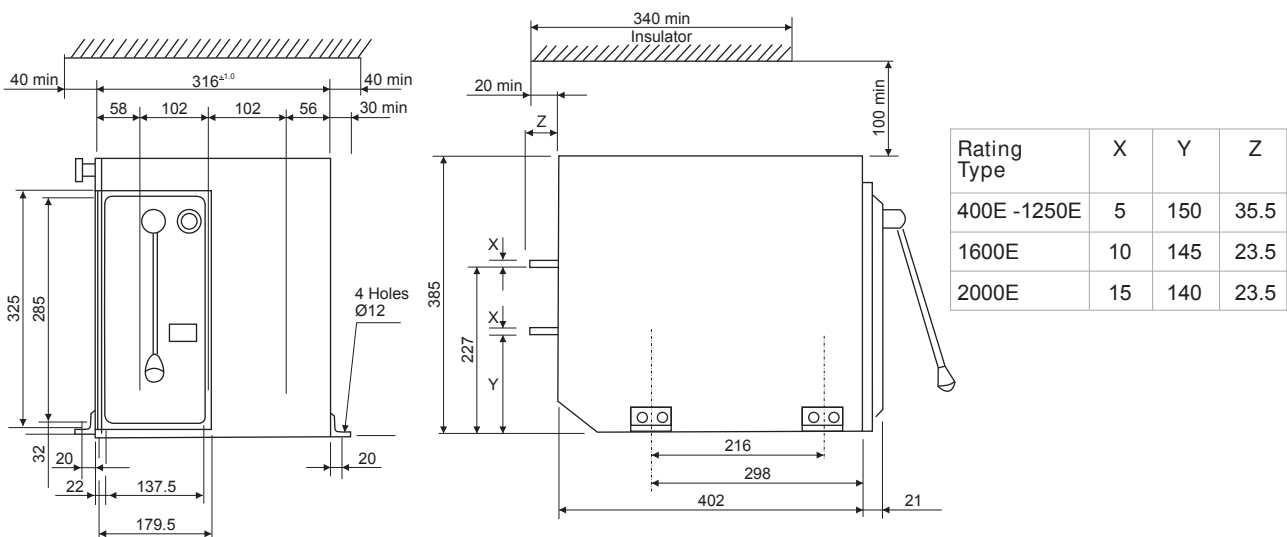

Note : All Dimensions are in mm.

OVERALL DIMENSIONS

Fixed Breakers

Terminal

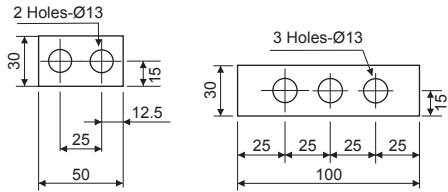

400 to 2000E, 800/1000/
1250/1600C/H &
400/630/800/1000
/1250/1600S1

2000/2500C/H

Terminal Connections

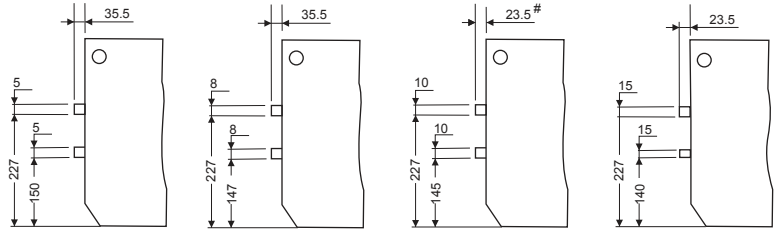

Terminal for 400/630 S1

Terminal for 800/1000 S1

Terminal for 800 C, 1000 C & 1250 S1
35.5 : For 1250S1

Terminal for 1600 S1, 800/1000 H, 1250/1600 C/H, 2000/2500 C/H

Bezel Fixing Plan for all Fixed Breakers

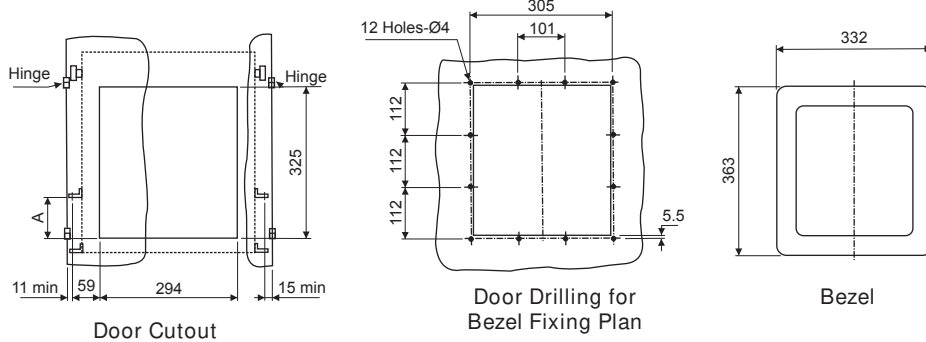

Note:
A = 89 for 4000C/3200D
A = 91 for other fixed ACBs

For 3200D/4000C 3P/4P

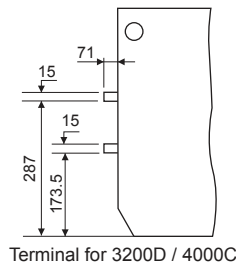
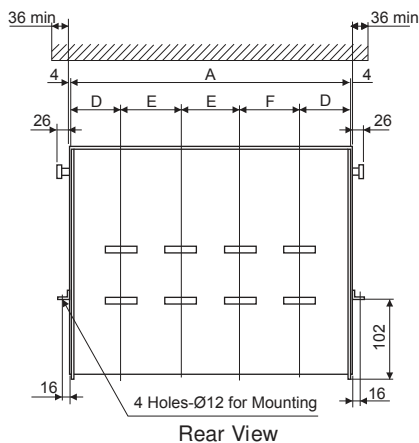
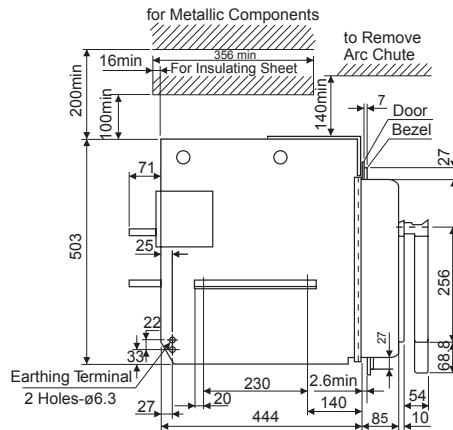
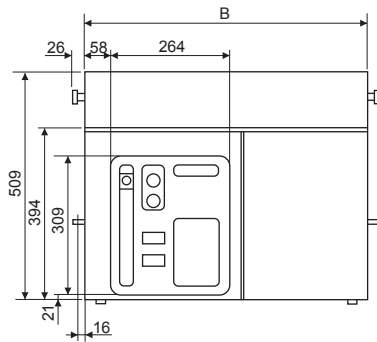

Terminal Connections

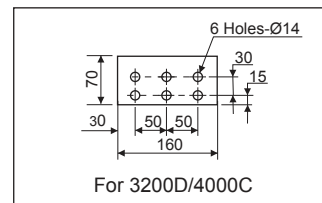

Rating CN-CS	Dimensions (mm)				
	A	B	D	E	F
3200D/4000A C 3P	628	636	112	202	-
3200D/4000A C 4P	830	838	112	202	202

OVERALL DIMENSIONS

Drawout Breakers

For 800A to 2500A C/H, 3200A H2/H1, 4000A H2/H, 400A to 3200A S1 3P/4P

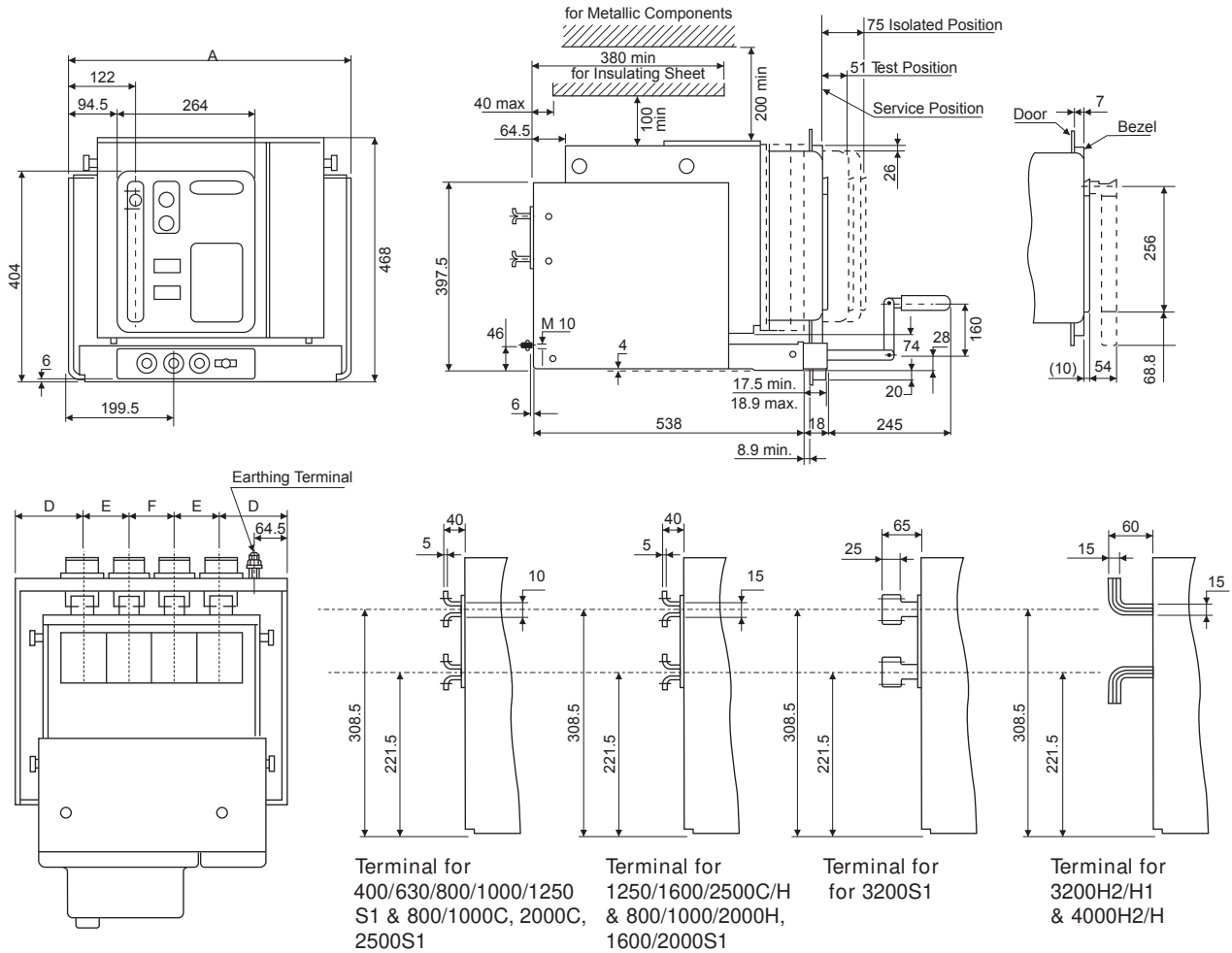

Ratings CN - CS			Dimensions (mm)			
			A	D	E	F
400/630/800/1000A	C/H/S1	3P	399	97.5	102	-
2000A	S1	3P				
1250/1600A	C/H/S1	3P	487	96.5	98	98
400/630/800/1000A	C/H/S1	4P				
2000A	S1	4P	555	123.5	154	-
1250/1600A	C/H/S1	4P				
2000/2500A	C/H	3P	701	122.5	150	156
2500/3200A	S1	3P				
2000/2500A	C/H	4P	701	148.5	202	-
2500/3200A	S1	4P				
3200A	H2/H1	3P	909	151.5	202	202
4000A	H2/H	3P				
3200A	H2/H1	4P	909	151.5	202	202
4000A	H2/H	4P				

Note : All Dimensions are in mm.

OVERALL DIMENSIONS

Drawout Breakers

Flat Terminal Connections

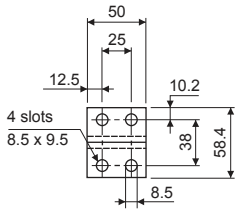

800 - 1000C & 400 - 1250S1

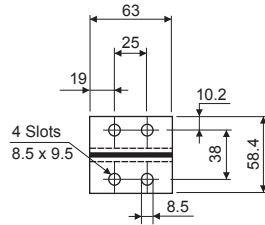

800 - 1000H, 1250/1600C/H & 1600 - 2000S1

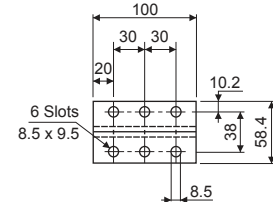

2000C

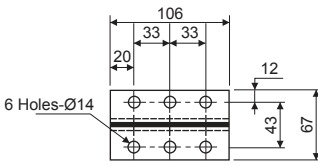

2500C/H & 2000H

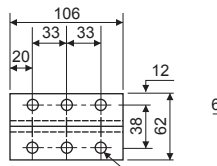

2500S1

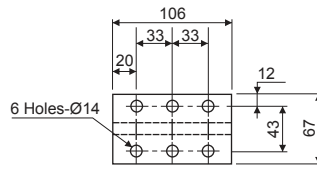

3200S1

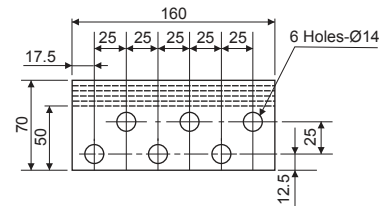

3200H2/H1 & 4000H2/H

For 3200D/4000/5000/6300C 3P/4P

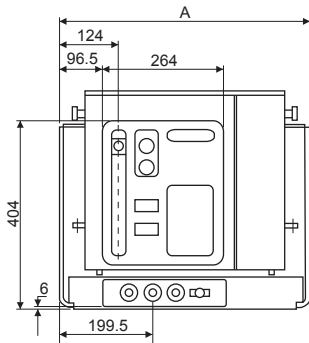

FRONT VIEW

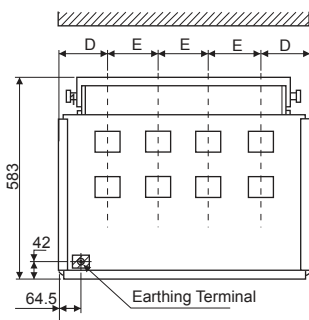

REAR VIEW

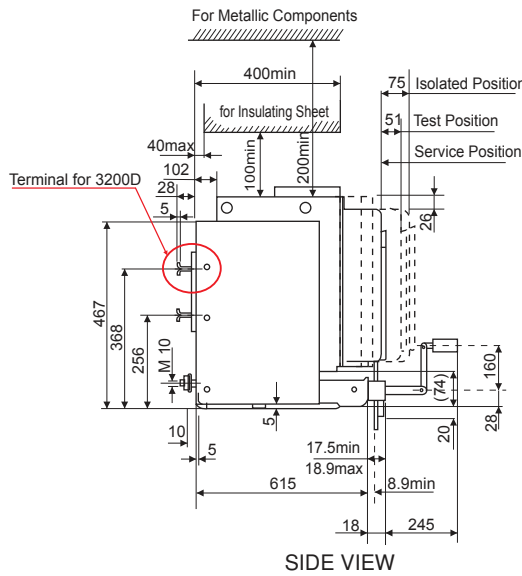

SIDE VIEW

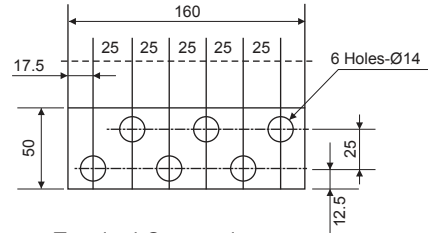

Terminal Connections
4000C

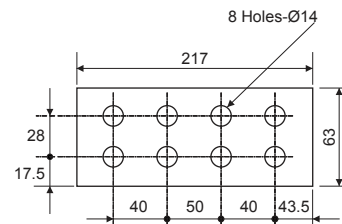

Terminal Connections
5000C/6300C

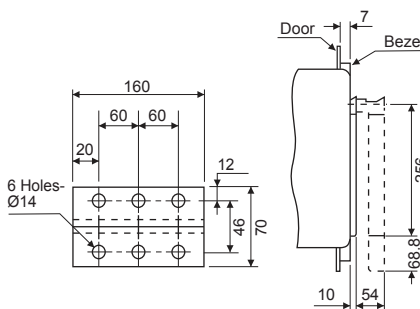

Terminal Connections
3200D

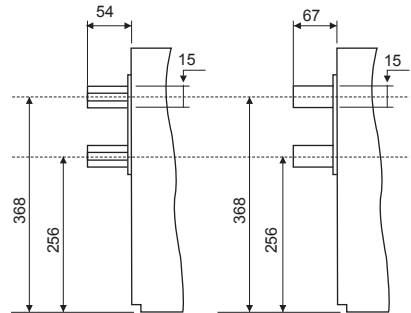

Terminal for
4000A C

Terminal for
5000/6300A C

Ratings	Dimensions (mm)		
	A	D	E
3200D/4000C 3P	711	155.5	200
3200D/4000C 4P	913	156.5	200
5000A/6300A 3P	913	187.5	269
5000A/6300A 4P	1182	187.5	269

OVERALL DIMENSIONS

Mounting Details

For Horizontal Mounting of all Draw-out Breakers

For 400A to 3200A C/H/ S1 3P/4P 3200 H2/H1, 4000 H2/H 3P/4P

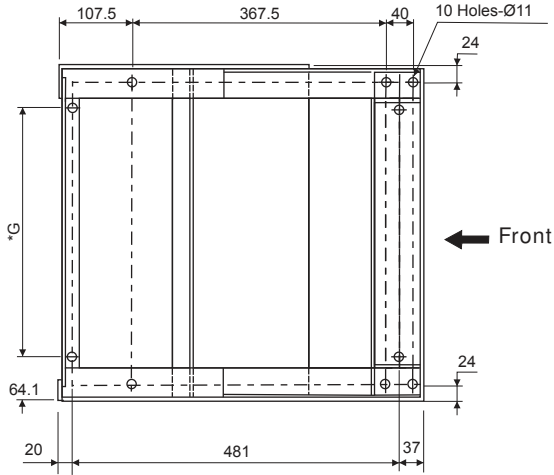

Ratings	Type	G (mm)
800A - 1600A 3P	C/H	280.3
400A - 2000A 3P	S1	280.3
800A - 1600A 4P	C/H	368.3
400A - 2000A 4P	S1	368.3
2000/2500A 3P	C/H	436.3
2000/2500A 4P	C/H	582.3
2500/3200A 3P	S1	436.3
2500/3200A 4P	S1	582.3
3200A 3P	H2/H1	582.3
3200A 4P	H2/H1	790.3
4000A 3P	H2/H	582.3
4000A 4P	H2/H	790.3

For 3200D/4000C/5000C/6300C 3P/4P

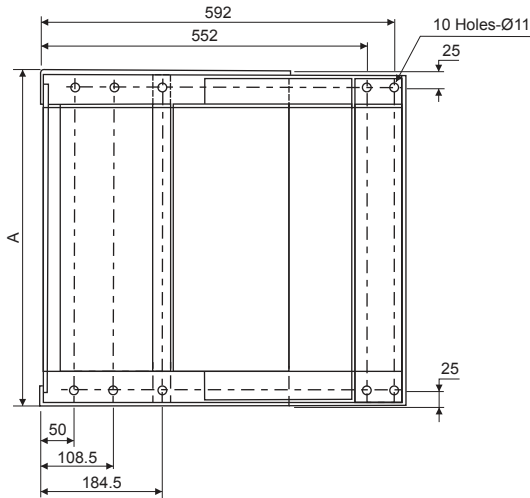

Ratings CN-CS	Dimensions
	A
3200D/4000C	711
3200D/4000C	913
5000C/6300C	913
5000C/6300C	1182

Bezel Fixing Plan for all Draw-out Breakers

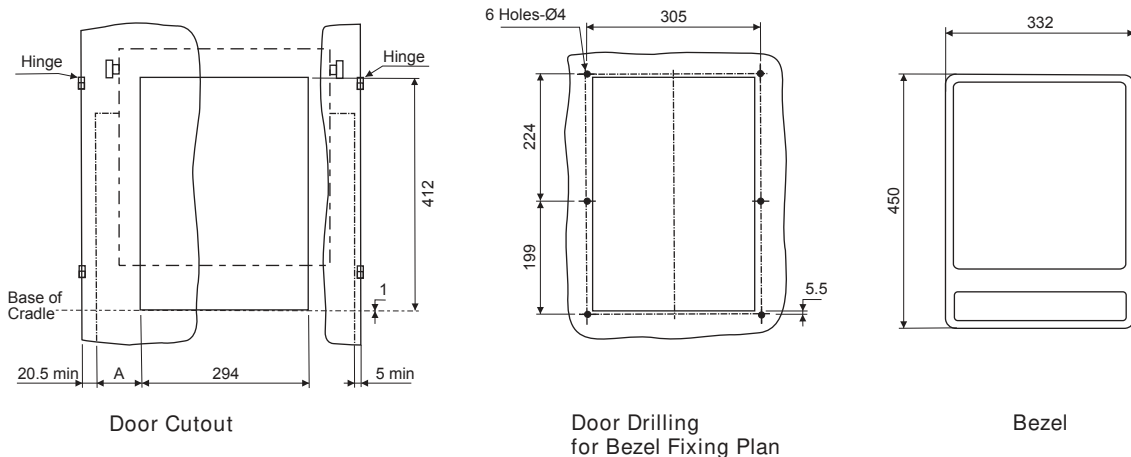

Note: For 3200A D 3P/4P, 4000A C 3P/4P, 5000C/6300C 3P/4P ACB, A=81.5
For other Drawout Breakers A=79.5

Note : All Dimensions are in mm.

OVERALL DIMENSIONS

Terminals

Horizontal Terminals

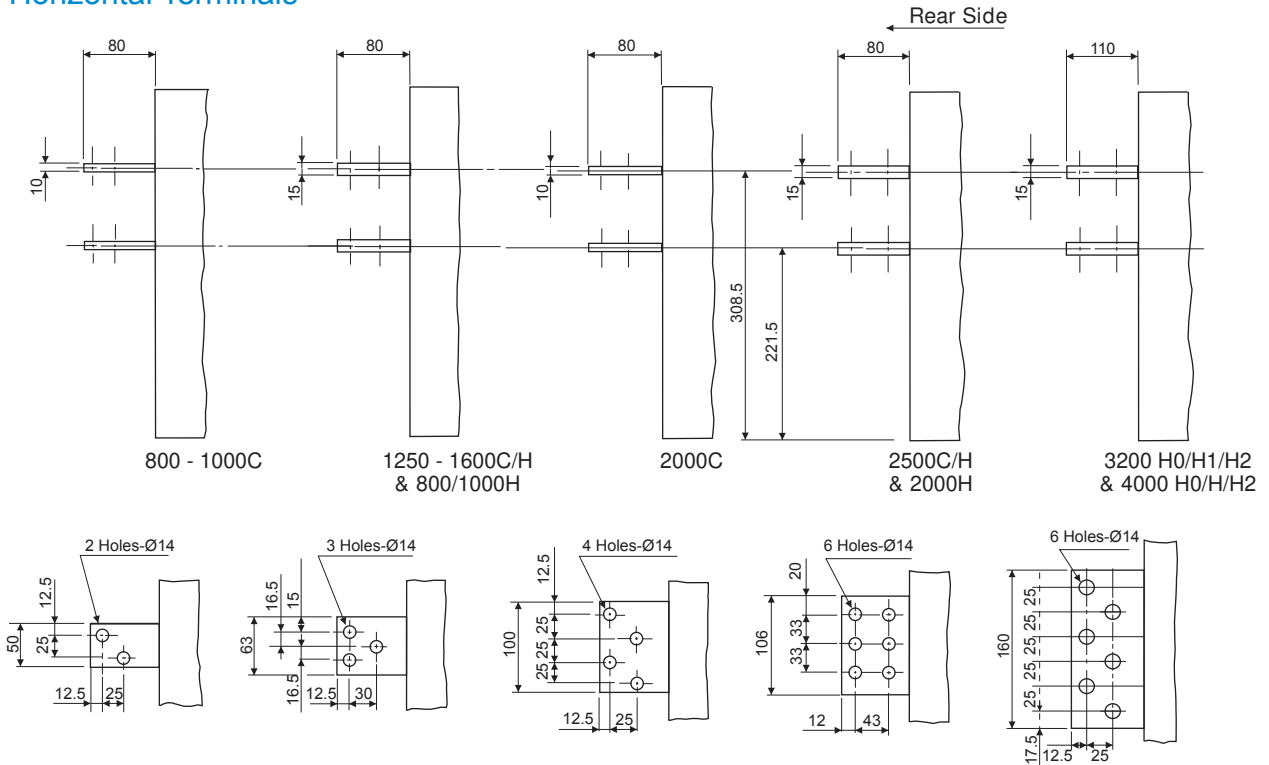

Vertical Terminals

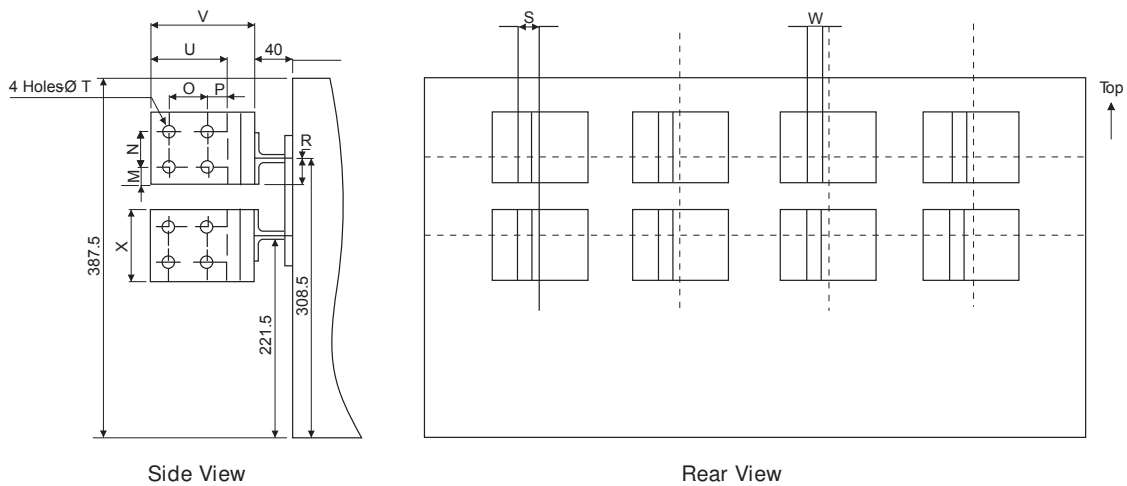

Ratings	M	N	P	Q	R	S	T	U	V	W	X
400-1250 S1 & 800-1000 C	10.2	38	20	25	29.2	5	9	65	95	10	58.4
1600-2000 S1 & 1250-1600 C/H	20	40	20	25	29.2	5	9	65	95	10	80
800-1000 H											
2000 C	20	40	20	40	29.2	22.5	14	80	110	15	80
2500 S1/ C/H	20	40	20	40	33.5	7.5	14	80	110	15	80
2000 H											
3200 S1	30	60	20	40	33.5	7.5	14	80	110	15	120

Note : 1) All Dimensions are in mm. 2) Consult us for other Terminal Orientations.

OVERALL DIMENSIONS

Terminals

Vertical Terminals 3200 H2/H1, 4000 H2/H

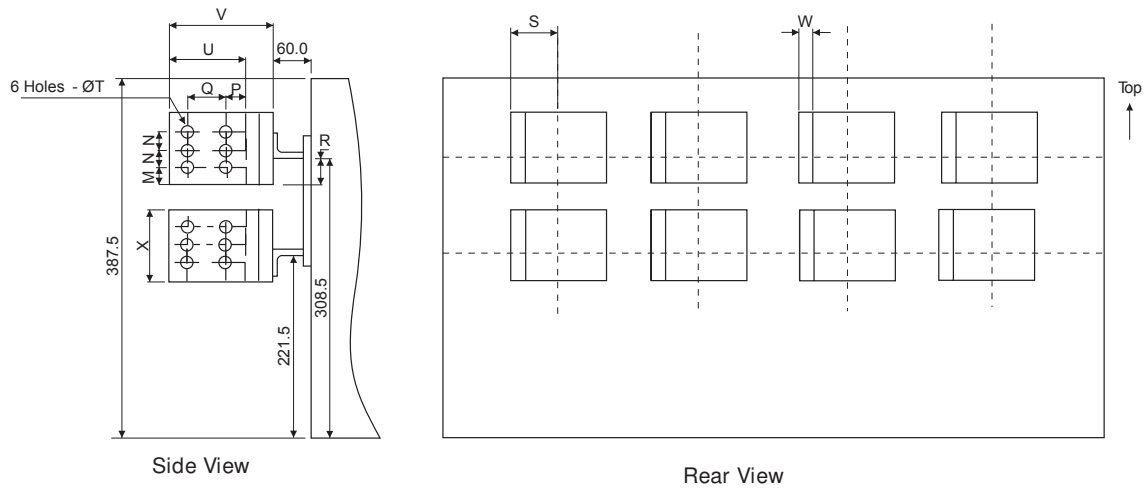

The dimensions for 3200 H2/H1 and 4000 H2/H are as under:

Ratings	M	N	P	Q	R	S	T	U	V	W	X
3200 H2/H1, 4000A H2/H	30	50	45	40	22.5	95	14	105	135	15	160

Get the Switchgear Training Edge!

Aimed at maximizing productivity, conserving energy, minimizing costs and enhancing safety, our Electrical & Automation training programmes have benefitted Lakh of professionals over the last three decades. These training programmes are highly beneficial as they provide right exposure and impart knowledge on selection, installation, maintenance and testing of Electrical & Automation Products.

Options to connect on Digital platform, At Training Centre or on-site Programs

So gain the advantage and go the extra mile with:

- Multiple courses on contemporary topics
- Brand Agnostic Trainings
- Training Centers in Pune, Lucknow, Coonoor, Vadodara, Delhi & Kolkata
- Blend of theory and practical experience

The typical training programmes cover:

- Low Voltage & Medium Voltage Switchgear
- Switchboard Electrical Design
- AC Drives & Building Management Solutions
- Protective Relays & Earthing
- Power Quality Solutions



Please contact any of the training centres for participation and detailed training programme schedule.



Pune
L&T Electrical & Automation
Training Centre
T-156 / 157, MIDC,
Bhosari,
Pune - 411 026
Tel: 020 2712 0037 / 2712 0653
E-mail: stc-pune@Lntebg.com



Lucknow
L&T Electrical & Automation
Training Centre
C-6 & 7, UPSIDC,
P. O. Sarojininagar,
Lucknow - 226 008
Tel: 0522 247 6015 / 97944 54455
E-mail: stc-lucknow@Lntebg.com



Delhi
L&T Electrical & Automation
Training Centre
32, Shivaji Marg,
Nearest Metro Stations Kirti Nagar/Moti Nagar,
New Delhi - 110015
Tel: 011- 40819515, 40819695, 40819500
E-mail: stc-delhi@Lntebg.com



Coonoor
L&T Electrical & Automation
Training Centre
Ooty-Coonoor Main Road
Yellanahalli P.O.,
The Nilgiris - 643 243
Tel. : 0423 251 7107
E-mail: stc-coonoor@Lntebg.com



Vadodara
L&T Electrical & Automation
Training Centre
Behind L&T Knowledge City,
Near Village Ankhol,
Vadodara - 390019
Tel: 0265 6147805 / 6147808
E-mail: stc-vadodara@Lntebg.com

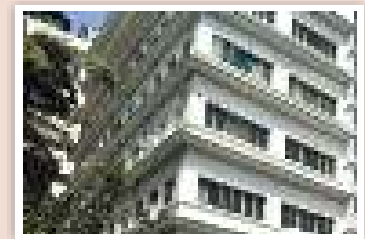

Kolkata
L&T Electrical & Automation
Training Centre
4th Floor, 3B, Shakespeare Sarani,
Landmark - Kenil Worth Hotel
Kolkata - 700071
Tel: 033 42005975 / 44085974 / 44085978
E-mail: stc-kolkata@Lntebg.com

Electrical Standard Products (ESP) Offices:

HEAD OFFICE

L&T Electrical & Automation
L&T Business Park, TC 2, Tower 'B'
3rd Floor, Gate No 5
Saki Vihar Road, Powai
Mumbai 400 072
Tel: 022-67052874 / 2737 / 1156
e-mail: cic@LNTEBG.com

BRANCH OFFICES

L&T Electrical & Automation
501, Sakar Complex I
Opp. Gandhigram Fly. Station
Ashram Road
Ahmedabad 380 009
Tel: 079 4900 4000 / 4010
e-mail: esp-ahm@LNTEBG.com

L&T Electrical & Automation
No 38, Cubbon Road
Bengaluru 560 001
Tel: 080-46136103 / 100
e-mail: esp-blr@LNTEBG.com

L&T Electrical & Automation
131/1, Zone II, Maharana Pratap Nagar
Bhopal 462 011
e-mail: esp-bho@LNTEBG.com

L&T Electrical & Automation
Plot No. 559, Annapurna Complex, 2nd Floor
Lewis Road
Bhubaneswar 751 014
Tel: 0674-2436690 / 9437453579 / 9437284376
e-mail: esp-bsr@LNTEBG.com

L&T Electrical & Automation
Aspire Towers, 4th Floor
Plot No. 55, Phase-I
Industrial & Business Park
Chandigarh 160 002
Tel: 0172-4646840 / 41 / 42 / 44 / 53
e-mail: esp-chd@LNTEBG.COM

L&T Electrical & Automation
L&T Construction Campus
TC-1 Building, II Floor
Mount-Poonamallee Road
Manapakkam
Chennai 600 089
Tel: 044-2270 6800
e-mail: esp-maa1@LNTEBG.com

L&T Electrical & Automation
Building E3A, Manufacturing Facility
L&T Bypass Road, Malumichampatti
Coimbatore 641 050
Tel: 0422-4588120 / 1 / 5
e-mail: esp-cbe@LNTEBG.com

L&T Electrical & Automation
3rd Floor, 1&2 Vijay Park,
Main Chakrata road
Ballapur Chowk
Dehradun 248001
Tel: +91 9582252411

L&T Electrical & Automation
Khairasol, Degaul Avenue
Durgapur 713 212
Tel: 0343-2540448 / 2540449 / 2540443
e-mail: esp-dgp@LNTEBG.com

L&T Electrical & Automation
5, Milanpur Road, Bamuni Maidan
Guwahati 781 021
Tel: +91 8876554417
e-mail: esp-ghy@LNTEBG.com

L&T Electrical & Automation
2nd Floor, Vasantha Chambers
5-10-173, Fateh Maidan Road
Hyderabad 500 004
Tel: 040-67015052
e-mail: esp-hyd@LNTEBG.com

L&T Electrical & Automation
Monarch Building, 1st Floor
D-236 & 237, Amrapali Marg
Vaishali Nagar
Jaipur 302 021
Tel: 0141-4385914 to 18
e-mail: esp-jai@LNTEBG.com

L&T Electrical & Automation
Akashdeep Plaza, 2nd Floor
P. O. Golmuri
Jamshedpur 831 003
Jharkhand
Tel: 0657-2340502 / 08
e-mail: esp-jam@LNTEBG.com

L&T Electrical & Automation
Skybright Bldg; M. G. Road
Ravipuram Junction, Ernakulam
Kochi 682 016
Tel: 0484-4409420 / 4 / 5 / 7
e-mail: esp-cok@LNTEBG.com

L&T Electrical & Automation
3-B, Shakespeare Sarani
Kolkata 700 071
Tel: 033-48006001
e-mail: esp-kol@LNTEBG.com

L&T Electrical & Automation
No. 10, Fortuna Tower, 2nd Floor
Rana Pratap Marg, Near NBRI
Lucknow 226001
e-mail: esp-Lko@LNTEBG.com

L&T Electrical & Automation
No: 73, Karpaga Nagar, 8th Street
K. Pudur
Madurai 625007
Tel: 0452-2567405 / 2561068 / 2561657
e-mail: esp-mdu@LNTEBG.com

L&T Electrical & Automation
L&T Business Park, TC 2, Tower 'B'
3rd Floor, Gate No 5
Saki Vihar Road, Powai
Mumbai 400 072
Tel: 022-67052874 / 2737 / 1156
e-mail: esp-bom@LNTEBG.com

L&T Electrical & Automation
Unnati Building, 2nd Floor
Automation Campus
A-600, TTC Industrial area
Shil-Mahape road, Mahape
Navi Mumbai 400710
Tel: +91 22 67226502 / 67226300

L&T Electrical & Automation
12, Shivaji Nagar
North Ambajhari Road
Nagpur 440 010
Tel: 0712-2260012 / 6606421
e-mail: esp-nag@LNTEBG.com

L&T Electrical & Automation
32, Shivaji Marg,
Near Moti Nagar,
P. O. Box 6223
New Delhi 110 015
Tel: 011-41419514 / 5 / 6
e-mail: esp-del@LNTEBG.com

L&T Electrical & Automation
Grand Chandra, 2nd Floor
Fraser Road
Opposite Doordarshan Kendra
Patna 800001
e-mail: esp-patna@LNTEBG.com

L&T Electrical & Automation
L&T House
P. O. Box 119
191/1, Dhole Patil Road
Pune 411 001
Tel: 020-48544395 / 48544279
e-mail: esp.pnq@LNTEBG.com

L&T Electrical & Automation
Crystal Tower,
4th Floor, G. E. Road
Telibandha
Raipur 492 006
Tel: +91 9755508228
e-mail: esp-raipur@LNTEBG.com

L&T Electrical & Automation
3rd Floor
Vishwakarma Chambers
Majura Gate, Ring Road
Surat 395 002
Tel: 0261-2473726
e-mail: esp-sur@LNTEBG.com

L&T Electrical & Automation
Radhadaya Complex
Old Padra Road
Near Charotar Society
Vadodara 390 007
Tel: 0265-6613610 / 1 / 2
e-mail: esp-bar@LNTEBG.com

L&T Electrical & Automation
Door No. 49-38-14/3/2, 1st floor,
NGGO's Colony, Akkayapalem,
Visakhapatnam 530 016
Tel: 0891-2791126 / 2711125
e-mail: esp-viz@LNTEBG.com

Product improvement is a continuous process. For the latest information and special application, please contact any of our offices listed here. Product photographs shown for representative purpose only.



L&T Electrical & Automation, Electrical Standard Products
L&T Business Park, TC-2, Tower B, 3rd Floor, Gate No. 5, Saki Vihar Road, Powai,
Mumbai - 400 072, INDIA www.lntebg.com

Customer Interaction Center (CIC)
BSNL / MTNL (toll-free): 1800 233 5858 Reliance (toll-free): 1800 200 5858
Tel: 022 6774 5858 Email: cic@lntebg.com Web: www.lntebg.com