

EXPERIENCE



A New Level of
Modular Protection From L&T



10 kA Modular Devices in L&T Range

ABOUT L&T

Larsen & Toubro is a technology, engineering, construction, manufacturing and services company with global operations. Strong customer-orientation, an innovative spirit and the constant quest for top-class quality have enabled L&T to attain and sustain leadership in its major lines of business for over seven decades.

L&T has set several global benchmarks of scale, speed and complexity in the projects it executes and the wide range of products it manufactures. With offerings that impact infrastructure development, hydrocarbon, power, aerospace and defence, the Company is seen in the role of nation-builder.

Internationally, L&T has a wide international presence with a manufacturing footprint that straddles eight countries, offices around the globe and collaborations with multiple global majors.



L&T is India's largest manufacturer of low tension switchgear. A wide range of products that suit specific needs of diverse industries, superior quality and a strong customer focused approach are reasons for the Company's leadership position over the years.

Products and solutions that enhance the safety of your homes and businesses through insulation and fire protection, cost saving due to lowering power consumption and flexibility are just a few of the advantages you gain.

In addition, you get the benefit of a network of vendors and service staff that ensure that your switchgear is routinely maintained to operate at its optimum.



EXORA

L&T Modular Devices

L&T's range of modular devices offer MCB, RCCB, Isolator and DB for final distribution of electrical power. L&T's products are known for reliability, functionality and ease of use.



L&T modular devices
spell world class

L&T products conform to relevant global standards viz. IEC, EN. They also have BIS and CE marking, as well as CB and KEMA certification.

 |  |  |  | 

L&T **EXORA**

L&T offers its new range of Modular Devices – **EXORA** – to ensure a safe environment around you. Protection and Control devices offered in this range provide safety at your home and at your workplace. Salient features of this range – Quick Break Mechanism, True Contact Position Indicator, Energy Limitation Class 3 – enhance safety of human lives and precious belongings.

Further, Low Watt loss of these products reduces the amount of electricity consumed and results in low electricity expense. Features such as Dual Termination and Two Position DIN Clip provide flexibility and ease of operation.

L&T's modular devices are complemented by a wide range of **EXORA** distribution boards which help to satisfy standard as well as tailor-made requirements. These distribution boards are user-friendly, with standard accessories and adequate space for wiring.



MODULAR DEVICES

1. Distribution Boards

1

2. Miniature Circuit Breakers (MCBs)

1. Features and Benefits
2. Ordering Information



37

3. Residual Current Circuit Breakers (RCCBs)

1. Features and Benefits
2. Ordering Information



44

4. Isolators

1. Features and Benefits
2. Ordering Information



49

5. Indicators

1. Features and Benefits
2. Ordering Information



54

6. Energy Meter – DIN-Rail Meters

1. Features and Benefits
2. Ordering Information



56

7. Time Switches

1. Features and Benefits
2. Ordering Information



60

8. Surge Protection Devices (SPDs)

1. Features and Benefits
2. Ordering Information



68

9. Single Phase ACCL

1. Features and Benefits
2. Ordering Information



71

Technical Index

76



DISTRIBUTION BOARDS



Distribution Boards

1. SPN Distribution Boards	2
2. TPN Distribution Boards	5
3. TPN Horizontal PPI Distribution Boards	8
4. TPN Tier – PPI Distribution Boards	11
5. TPN Vertical Distribution Boards (Modular Incomer)	14
6. TPN Vertical Distribution Boards (MCCB Incomer)	17
7. TPN Phase Segregated Distribution Boards	20
8. TPN Phase Selector Distribution Boards	23
9. Flexi Distribution Boards	26
10. Enclosures	29
11. Plug & Socket Distribution Boards	31

SPN Distribution Boards



Metal DBs for Single Phase and Neutral (SPN) supply distribution

Technical Data

- As per IS 8623
- No. of modules – 4, 6, 8, 12, 16, 18 way
- Mounting – Surface / Flush mounting
- IP category
 - IP 30 for single door
 - IP 43/54 for double door
- Material – CRCA sheet steel
- Colour – RAL 9003, powder-coated

Features and Benefits

- Equipped with colour-coded wires set
- 100A tin-plated insulated copper busbar
- Cement spill protector in double door DBs
- Choice of plain or glazed door
- Door earthing in double-door DBs
- Removable gland plates and front plate
- Insulated neutral bar
- Cable ties, blank plates and circuit identification labels
- Plastic inserts on corners for modern looks and corner protection

SPN Distribution Boards

Description	No. of Modules	Cat. Nos.
IP 30-Single Door		
6 way	6	LTSC06N
8 way	8	LTSC08N
12 way	12	LTSC12N
16 way	16	LTSC16N
18 way	18	LTSC18N
IP 43-Double Door : Plain		
4 way	4	LTSD04N
6 way	6	LTSD06N
8 way	8	LTSD08N
12 way	12	LTSD12N
16 way	16	LTSD16N
18 way	18	LTSD18N
IP 43-Double Door : Glazed		
4 way	4	LTSD04GN
6 way	6	LTSD06GN
8 way	8	LTSD08GN
12 way	12	LTSD12GN
16 way	16	LTSD16GN
18 way	18	LTSD18GN
IP 54-Double Door : Plain		
4 way	4	LTSD04N54
6 way	6	LTSD06N54
8 way	8	LTSD08N54
12 way	12	LTSD12N54
16 way	16	LTSD16N54
18 way	18	LTSD18N54

Dimensions

IP30 Single Door

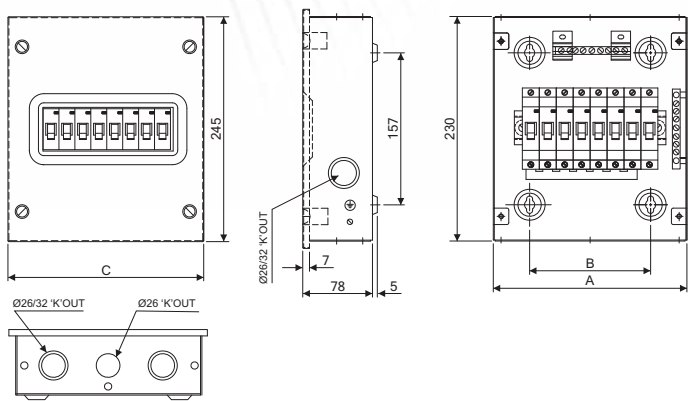

IP43 Double Door – Metal Door

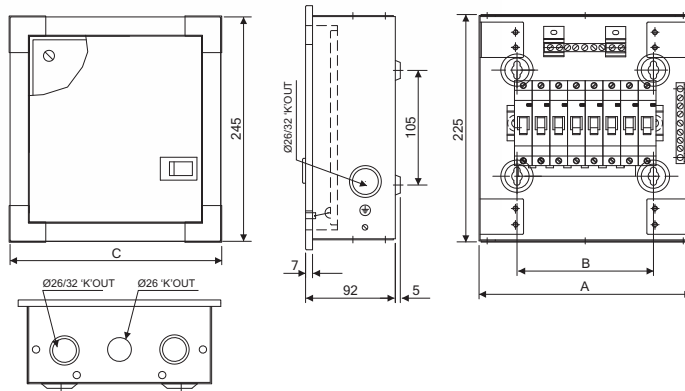

Way	A	B	C	Top/Bottom		
				Ø26, 'K'OUT	Ø26/32 'K'OUT	Side 'K'OUT
4	170	95	185	--	4Nos.	2Nos.
6	200	125	215	2Nos.	4Nos.	2Nos.
8	270	195	290	4Nos.	4Nos.	2Nos.
12	350	275	365	6Nos.	4Nos.	2Nos.
16	390	315	410	8Nos.	4Nos.	2Nos.

Way	A	B	C	Top/Bottom		
				Ø26	Ø26/32	Side 'K'OUT
4	140	65	160	--	4Nos.	2Nos.
6	175	100	195	--	4Nos.	2Nos.
8	210	135	230	2Nos.	4Nos.	2Nos.
12	285	210	305	4Nos.	4Nos.	2Nos.
16	365	290	385	6Nos.	4Nos.	2Nos.
18	400	325	420	8Nos.	4Nos.	2Nos.

IP43 Double Door – Glazed Door

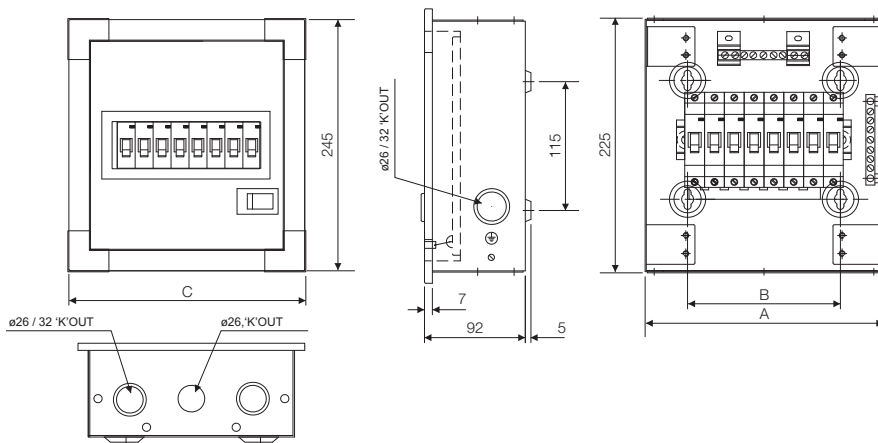

Way	A	B	C	Top/Bottom		
				Ø26, 'K'OUT	Ø26/32 'K'K'OUT	Side 'K'OUT
4	140	65	160	--	4Nos.	2Nos.
6	175	100	195	---	4Nos.	2Nos.
8	210	135	230	2Nos.	4Nos.	2Nos.
12	285	210	305	4Nos.	4Nos.	2Nos.
16	365	290	385	6Nos.	4Nos.	2Nos.
18	400	325	420	8Nos.	4Nos.	2Nos.

All dimensions are in mm

TPN Distribution Boards



Metal DBs for Three-Phase and Neutral (TPN) supply distribution

Technical Data

- As per IS 8623
- No. of modules – 4 ,6, 8 ,12,16 way
- Mounting – Surface / Flush mounting
- IP category
 - IP 30 for single door
 - IP 43/54 for double door
- Material – CRCA sheet steel
- Colour – RAL 9003, powder-coated

Features and Benefits

- Equipped with colour-coded wires set
- 100A tin-plated insulated copper busbar
- Cement spill protector in double door DBs
- Choice of plain or glazed door
- Door earthing in double door DBs
- Removable gland plates and front plate
- Insulated neutral bar
- Cable ties, blank plates and circuit identification labels
- Plastic inserts on corners for modern looks and corner protection

TPN Distribution Boards

Description	No. of Modules	Cat. Nos.
IP 30-Single Door		
4 way+	4+12	L TTC04NE
4 way	8+12	L TTC04N
6 way	8+18	L TTC06N
8 way	8+24	L TTC08N
12 way	8+36	L TTC12N
IP 43-Double Door : Plain		
4 way+	4+12	L TTD04NE
4 way	8+12	L TTD04N
6 way	8+18	L TTD06N
8 way	8+24	L TTD08N
12 way	8+36	L TTD12N
16 way	8+48	L TTD16N
IP 43-Double Door : Glazed		
4 way+	4+12	L TTD04GNE
4 way	8+12	L TTD04GN
6 way	8+18	L TTD06GN
8 way	8+24	L TTD08GN
12 way	8+36	L TTD12GN
16 way	8+48	L TTD16GN
IP 54-Double Door : Plain		
4 way	8+12	L TTD04N54
6 way	8+18	L TTD06N54
8 way	8+24	L TTD08N54
12 way	8+36	L TTD12N54
16 way	8+48	L TTD16N54

Dimensions

IP30 Single Door - 4 Mod Incomer

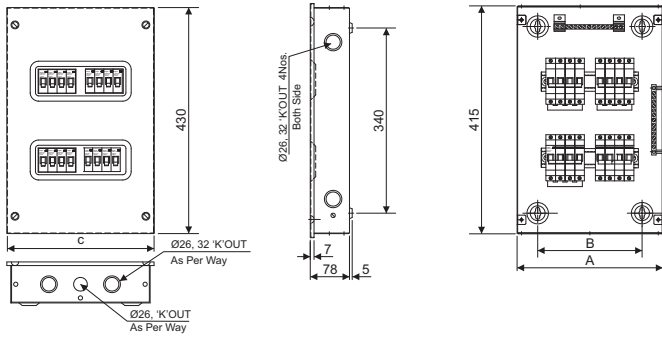

Way	A	B	C	Ø26, 'K'OUT		Ø26/32, 'K'OUT
				Top	Bottom	T & B
4	265	190	285	1Nos.	1Nos.	2Nos.

IP30 Single Door

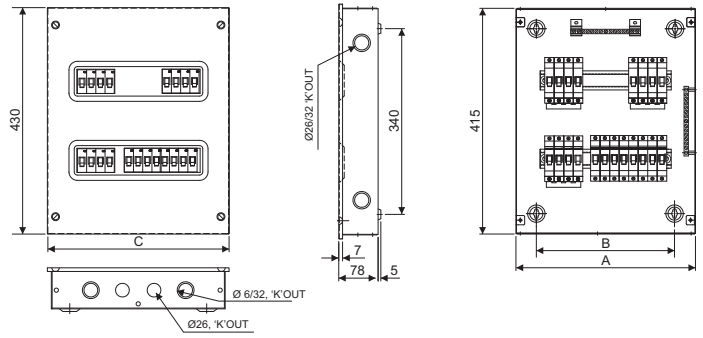

Way	I/C	A	B	C	Top/Bottom	Top/Bottom	Side 'K'OUT
					Ø26	Ø26/32	Ø26/32
4	4P	265	190	285	2Nos.	4Nos.	4Nos.
4	8P	330	255	345	4Nos.	4Nos.	4Nos.
6	8P	365	290	380	6Nos.	4Nos.	4Nos.
8	8P	460	385	475	10Nos.	4Nos.	4Nos.
12	8P	600	525	615	14Nos.	4Nos.	4Nos.
16	8P	700	625	715	18Nos.	4Nos.	4Nos.

IP43 Double Door - Metal Door

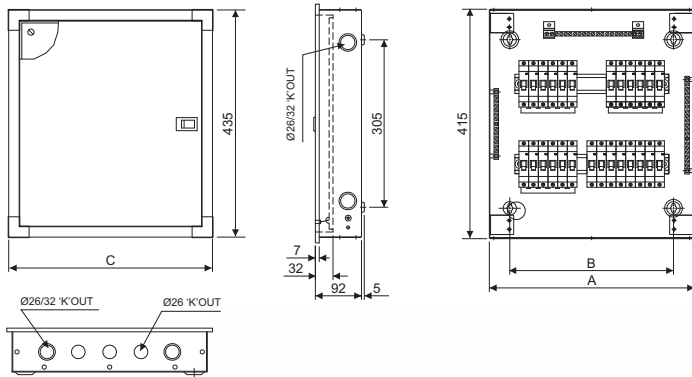

Way	I/C	A	B	C	Top/Bottom	Top/Bottom	Side 'K'OUT
					Ø26	Ø26/32	Ø26/32
4	4P	280	210	300	4Nos.	4Nos.	4Nos.
4	8P	330	255	350	6Nos.	4Nos.	4Nos.
6	8P	370	295	390	6Nos.	4Nos.	4Nos.
8	8P	440	365	460	8Nos.	4Nos.	4Nos.
12	8P	630	555	650	16Nos.	4Nos.	4Nos.
16	8P	775	700	795	20Nos.	4Nos.	4Nos.

IP43 Double Door - Glazed Door

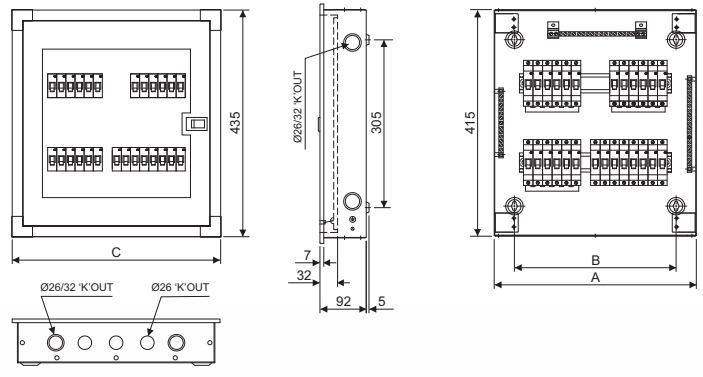

Way	I/C	A	B	C	Top/Bottom	Top/Bottom	Side 'K'OUT
					Ø26	Ø26/32	Ø26/32
4	4P	280	210	300	4Nos.	4Nos.	4Nos.
4	8P	330	255	350	6Nos.	4Nos.	4Nos.
6	8P	370	295	390	6Nos.	4Nos.	4Nos.
8	8P	440	365	460	8Nos.	4Nos.	4Nos.
12	8P	630	555	650	16Nos.	4Nos.	4Nos.
16	8P	775	700	795	20Nos.	4Nos.	4Nos.

All Dimensions are in mm

TPN Horizontal PPI Distribution Boards



Metal DBs for Three Phase and Neutral (TPN) supply distribution with Per Phase Isolation (PPI)

Technical Data

- As per IS 8623
- No. of modules – 4+2, 6+2, 8+2, 12+2 way
- Mounting – Surface / Flush mounting
- IP category
 - IP 43/54 for double door
 - Material – CRCA sheet steel
- Colour – RAL 9003, powder-coated

Features and Benefits

- Provisions to mount 2P RCCBs in each phase as sub-incomer
- Equipped with colour-coded wires set
- 100A tin-plated insulated copper bus-bar
- Cement spill protector
- Choice of plane or glazed door
- Door earthing in double door DBs
- Removable gland plates and front plates
- Insulated neutral bar
- Cable ties, blank plates and circuit identification labels
- Plastic inserts on corners for modern looks and corner protection

TPN Horizontal PPI Distribution Boards

Description	No. of Modules	Cat. Nos.
IP 43-Double Door : Plain		
4+2 way	8+6+12	LTHPD04N
6+2 way	8+6+18	LTHPD06N
8+2 way	8+6+24	LTHPD08N
12+2 way	8+6+36	LTHPD12N
IP 43-Double Door : Glazed		
4+2 way	8+6+12	LTHPD04GN
6+2 way	8+6+18	LTHPD06GN
8+2 way	8+6+24	LTHPD08GN
12+2 way	8+6+36	LTHPD12GN
IP 54-Double Door : Plain		
4+2 way	8+6+12	LTHPD04N54
6+2 way	8+6+18	LTHPD06N54
8+2 way	8+6+24	LTHPD08N54
12+2 way	8+6+36	LTHPD12N54

Dimensions

IP43 Double Door – Glazed Door

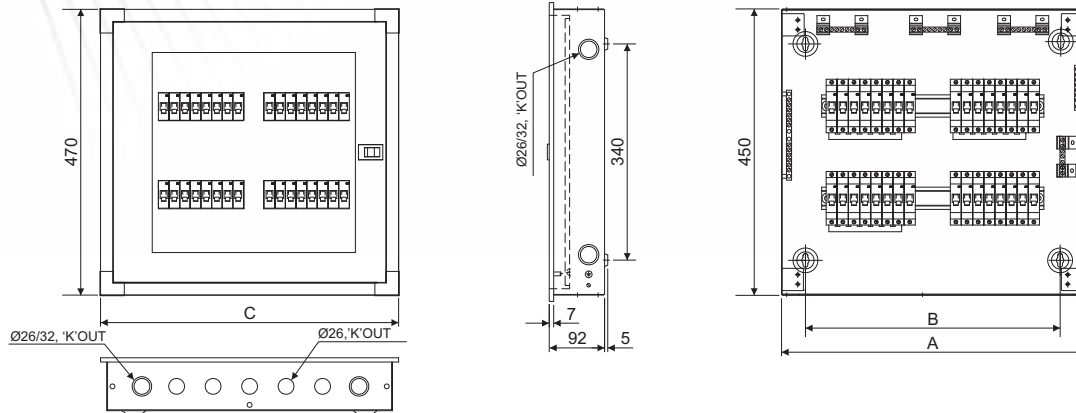

Way	I/C	A	B	C	Top/Bottom	Top/Bottom	Side 'K'OUT
					Ø26	Ø26/32	Ø26/32
4+2	8P	375	300	395	6Nos.	4Nos.	4Nos.
6+2	8P	470	395	490	10Nos.	4Nos.	4Nos.
8+2	8P	540	465	560	12Nos.	4Nos.	4Nos.
12+2	8P	680	605	700	16Nos.	4Nos.	4Nos.
16+2	8P	825	750	845	22Nos.	4Nos.	4Nos.

IP43 Double Door – Metal Door

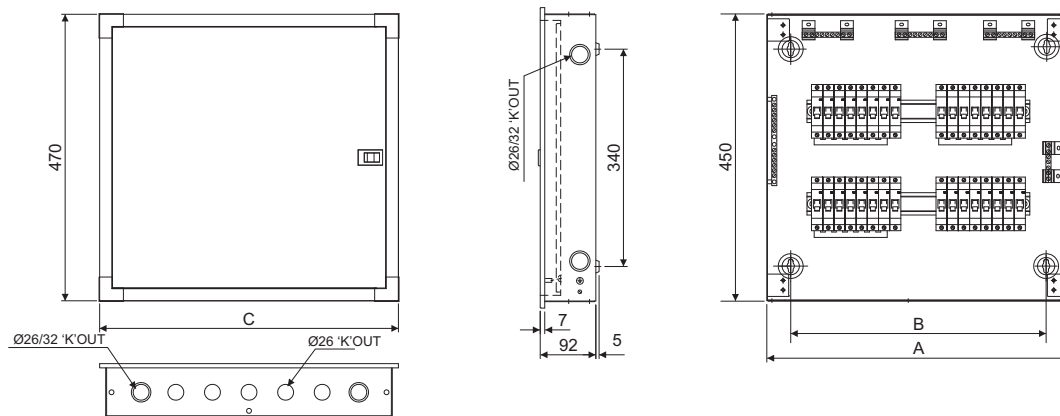

Way	I/C	A	B	C	Top/Bottom	Top/Bottom	Side 'K'OUT
					Ø26	Ø26/32	Ø26/32
4+2	8P	375	300	395	6Nos.	4Nos.	4Nos.
6+2	8P	470	395	490	10Nos.	4Nos.	4Nos.
8+2	8P	540	465	560	12Nos.	4Nos.	4Nos.
12+2	8P	680	605	700	16Nos.	4Nos.	4Nos.
16+2	8P	825	750	845	22Nos.	4Nos.	4Nos.

All dimensions are in mm

TPN Tier PPI Distribution Boards



Metal Tier DBs for Three-Phase and Neutral (TPN) supply distribution with Per Phase Isolation (PPI)

Technical Data

- As per IS 8623
- No. of modules – 6+2, 8+2, 10+2, 12+2 way
- Mounting – Surface / Flush mounting
- IP category
 - IP 43/54 for double door
 - Material – CRCA sheet steel
- Colour – RAL 9003, powder-coated

Features and Benefits

- Provisions to mount 2P RCCBs in each phase as sub-incomer
- Equipped with colour-coded wires set
- 100A tin-plated insulated copper bus-bar
- Cement spill protector
- Choice of plane or glazed door
- Door earthing in double door DBs
- Removable gland plates and front plates
- Insulated neutral bar
- Cable ties, blank plates and circuit identification labels
- Plastic inserts on corners for modern looks and corner protection

TPN Tier PPI Distribution Boards

Description	No. of Modules	Cat. Nos.
IP 43-Double Door : Plain		
6+2 way	8+6+18	LTPPD06N
8+2 way	8+6+24	LTPPD08N
10+2 way	8+6+30	LTPPD10N
12+2 way	8+6+36	LTPPD12N
16+2 way	8+6+48	LTPPD16N
12+2 way+	MCCB+6+36	LTPPD12MN
IP 43-Double Door : Glazed		
6+2 way	8+6+18	LTPPD06GN
8+2 way	8+6+24	LTPPD08GN
10+2 way	8+6+30	LTPPD10GN
12+2 way	8+6+36	LTPPD12GN
16+2 way	8+6+48	LTPPD16GN
12+2 way+	MCCB+6+36	LTPPD12MGN
IP 54-Double Door : Plain		
6+2 way	8+6+18	LTPPD06N54
8+2 way	8+6+24	LTPPD08N54
10+2 way	8+6+30	LTPPD10N54
12+2 way	8+6+36	LTPPD12N54
12+2 way+	MCCB+6+36	LTPPD12MN54

- Provision to mount MCCB type DH 3P up to 125A

Dimensions

IP43 Double Door - Metal Door (Modular I/C)

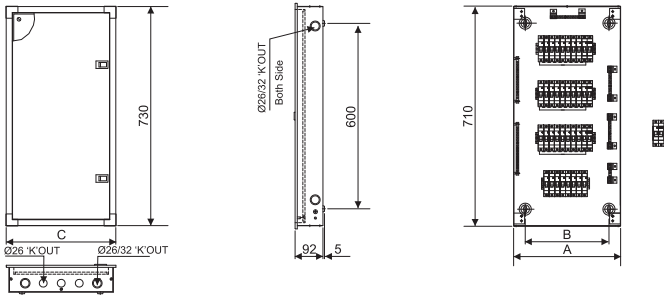

Way	I/C	A	B	C	Top/Bottom		
					Ø26	Ø26/32	Ø26/32
6+2	8P	310	235	330	4Nos.	4Nos.	4Nos.
8+2	8P	345	270	365	6Nos.	4Nos.	4Nos.
10+2	8P	385	310	405	8Nos.	4Nos.	4Nos.
12+2	8P	425	350	445	8Nos.	4Nos.	4Nos.
16+2	8P	500	430	520	10Nos.	4Nos.	4Nos.

IP43 Double Door - Metal Door (MCCB I/C)

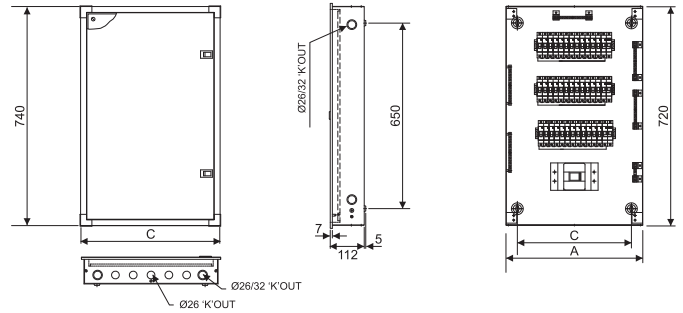

Way	I/C	A	B	C	Top/Bottom		
					Ø26	Ø26/32	Ø26/32
12+2	MCCB	450	375	470	10Nos.	1Nos.	4 Nos.

IP43 Double Door - Glazed Door (MCCB I/C)

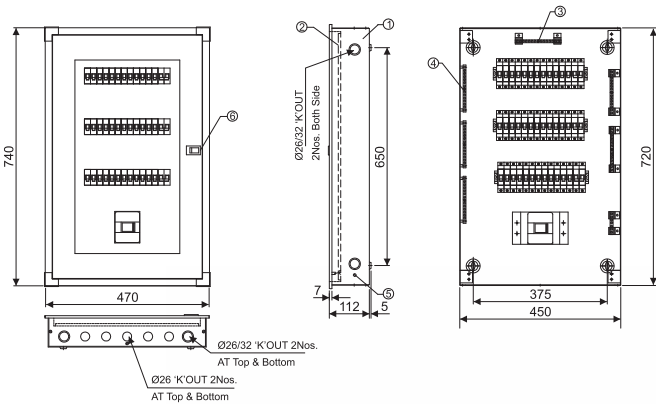

Way	I/C	A	B	C	Top/Bottom		
					Ø26	Ø26/32	Ø26/32
12+2	MCCB	450	375	470	10Nos.		4Nos.

IP43 Double Door - Glazed Door (Modular I/C)

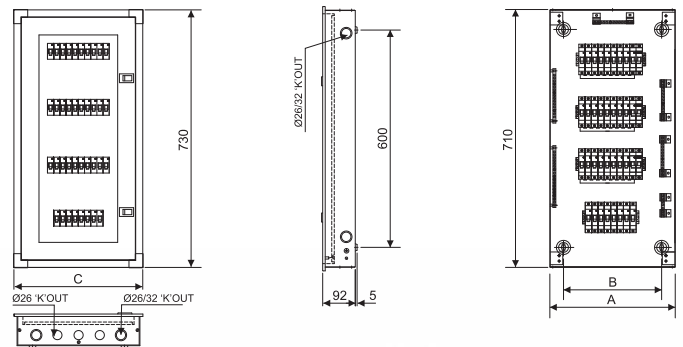

Way	I/C	A	B	C	Top/Bottom		
					Ø26	Ø26/32	Ø26/32
6+2	8P	310	235	330	4Nos.	4Nos.	4Nos.
8+2	8P	345	270	365	6Nos.	4Nos.	4Nos.
10+2	8P	385	310	405	8Nos.	4Nos.	4Nos.
12+2	8P	425	350	445	8Nos.	4Nos.	4Nos.
16+2	8P	500	430	520	10Nos.	4Nos.	4Nos.

All dimensions are in mm

TPN Vertical Distribution Boards (Modular Incomer)



Metal DBs with 200A vertical bus-bar for Three-Phase and Neutral (TPN) supply distribution

Technical Data

- As per IS 8623
- No. of modules – 4, 6, 8, 12, 16 way
- Mounting – Surface / Flush mounting
- IP category
 - IP 30 for single door
 - IP 43/54 for double door
- Material – CRCA sheet steel
- Colour – RAL 9003, powder-coated
- Busbar rating – 200A
- Short-circuit withstand – 10kA

Features and Benefits

- 200A vertical bus-bar with 10kA fault withstand capacity
- Cement spill protector in double door DBs
- Choice of plain or glazed door
- Door earthing in double door DBs
- Removable gland plates and front plate
- Insulated neutral bar
- Cable ties, blank plates and circuit identification labels
- Plastic inserts on corners for modern looks and corner protection

TPN Vertical Distribution Boards (Modular Incomer)

Description	No. of Modules	Cat. Nos.
IP 30-Single Door		
4 way	8+12	LTVC04N
6 way	8+18	LTVC06N
8 way	8+24	LTVC08N
12 way	8+36	LTVC12N
IP 43-Double Door : Plain		
4 way	8+12	LTVD04N
6 way	8+18	LTVD06N
8 way	8+24	LTVD08N
12 way	8+36	LTVD12N
16 way	8+48	LTVD16N
IP 43-Double Door : Glazed		
4 way	8+12	LTVD04GN
6 way	8+18	LTVD06GN
8 way	8+24	LTVD08GN
12 way	8+36	LTVD12GN
16 way	8+48	LTVD16GN
IP 54-Double Door : Plain		
4 way	8+12	LTVD04N54
6 way	8+18	LTVD06N54
8 way	8+24	LTVD08N54
12 way	8+36	LTVD12N54
16 way	8+48	LTVD16N54

Dimensions

IP30 Single Door

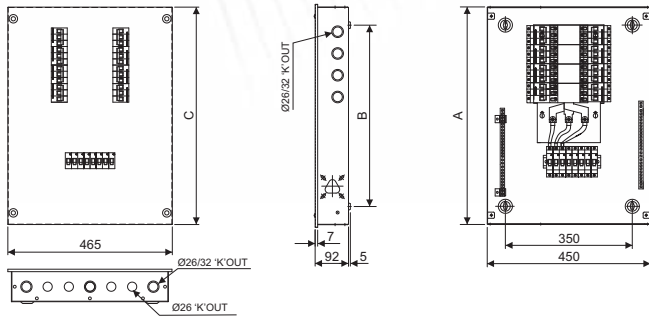

IP43 Double Door – Metal Door

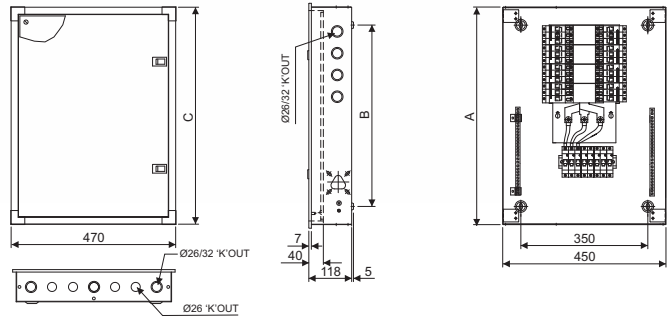

Way	I/C	A	B	C	Top/Bottom	Top/Bottom	Side 'K'OUT
					Ø26	Ø26/32	Ø26/32
4	8P	500	400	515	10Nos.	4Nos.	4Nos.
6	8P	550	450	565	10Nos.	4Nos.	6Nos.
8	8P	600	500	615	10Nos.	4Nos.	8Nos.
12	8P	700	600	715	10Nos.	4Nos.	12Nos.

Way	I/C	A	B	C	Top/Bottom	Top/Bottom	Side 'K'OUT
					Ø26	Ø26/32	Ø26/32
4	8P	500	400	520	8Nos.	6Nos.	4Nos.
6	8P	550	450	570	8Nos.	6Nos.	6Nos.
8	8P	600	500	620	8Nos.	6Nos.	8Nos.
12	8P	700	600	720	8Nos.	6Nos.	12Nos.
16	8P	800	700	820	8Nos.	6Nos.	16Nos.

IP43 Double Door – Glazed Door

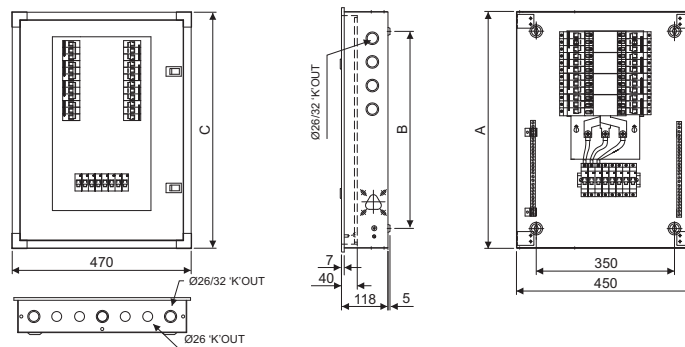

Way	I/C	A	B	C	Top/Bottom	Top/Bottom	Side 'K'OUT
					Ø26	Ø26/32	Ø26/32
4	8P	500	400	520	8Nos.	6Nos.	4Nos.
6	8P	550	450	572	8Nos.	6Nos.	6Nos.
8	8P	600	500	620	8Nos.	6Nos.	8Nos.
12	8P	700	600	720	8Nos.	6Nos.	12Nos.
16	8P	800	800	820	8Nos.	6Nos.	16Nos.

All dimensions are in mm

TPN Vertical Distribution Boards (MCCB Incomer)



Metal DBs with 200A vertical bus-bar for Three Phase and Neutral (TPN) supply distribution with MCCB as incomer

Technical Data

- As per IS 8623
- No. of modules – 4, 6, 8, 12, 16 way
- Mounting – Surface / Flush mounting
- IP category – IP 43/54 for double door
- Material – CRCA sheet steel
- Colour – RAL 9003, powder-coated
- Busbar rating – 200A
- Short-circuit withstand –10kA

Features and Benefits

- 200A vertical bus-bar with 10kA fault withstand capacity
- Cement spill protector in double door DBs
- Choice of plain or glazed door
- Door earthing in double door DBs
- Removable gland plates and front plate
- Insulated neutral bar
- Cable ties, blank plates and circuit identification labels
- Plastic inserts on corners for modern looks and corner protection

TPN vertical Distribution Boards (MCCB Incomer)

Description	No. of Modules	Cat. Nos.
IP 43-Double Door : Plain		
4 way	MCCB + 12	LTVD04MN
6 way	MCCB + 18	LTVD06MN
8 way	MCCB + 24	LTVD08MN
12 way	MCCB + 36	LTVD12MN
16 way	MCCB + 48	LTVD16MN
IP 43-Double Door : Glazed		
4 way	MCCB + 12	LTVD04MGN
6 way	MCCB + 18	LTVD06MGN
8 way	MCCB + 24	LTVD08MGN
12 way	MCCB + 36	LTVD12MGN
16 way	MCCB + 48	LTVD16MGN
IP-54 Double Door : Plain		
4 way	MCCB + 12	LTVD04MN54
6 way	MCCB + 18	LTVD06MN54
8 way	MCCB + 24	LTVD08MN54
12 way	MCCB + 36	LTVD12MN54
16 way	MCCB + 48	LTVD16MN54

- Provision to mount MCCB type DH 3P up to 125A

Dimensions

IP43 Double Door – Metal Door

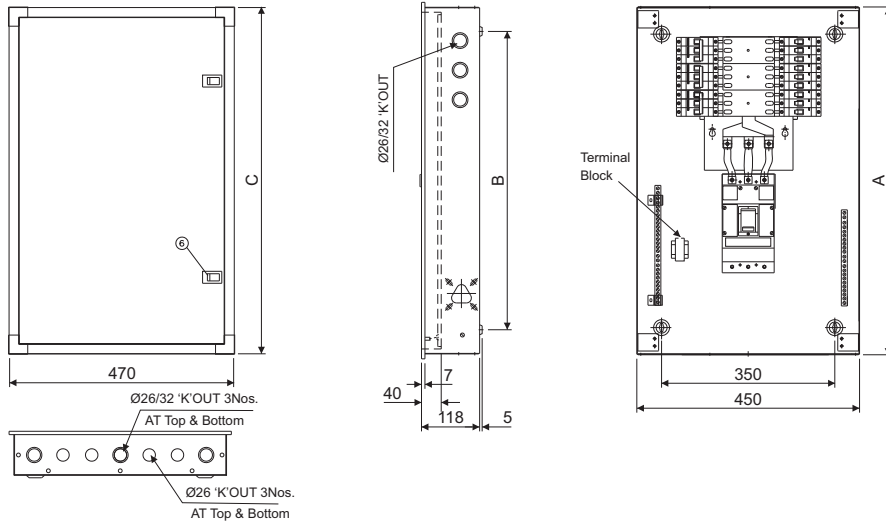

Way	I/C	A	B	C	Top/Bottom		
					Ø26	Ø26/32	Side 'K'OUT
4	MCCB	653	550	673	8Nos.	6Nos.	4Nos.
6	MCCB	700	600	720	8Nos.	6Nos.	6Nos.
8	MCCB	757	657	777	8Nos.	6Nos.	8Nos.
12	MCCB	864	764	884	8Nos.	6Nos.	12Nos.
16	MCCB	970	870	990	8Nos.	6Nos.	16Nos.

IP43 Double Door – Glazed Door

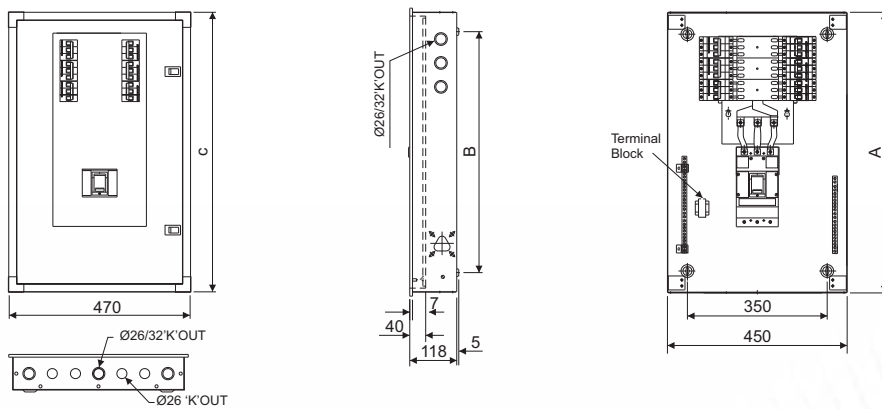

Way	I/C	A	B	C	Top/Bottom		
					Ø26	Ø26/32	Side 'K'OUT
4	MCCB	653	550	673	8Nos.	6Nos.	4Nos.
6	MCCB	700	600	720	8Nos.	6Nos.	6Nos.
8	MCCB	757	657	777	8Nos.	6Nos.	8Nos.
12	MCCB	864	764	884	8Nos.	6Nos.	12Nos.
16	MCCB	970	870	990	8Nos.	6Nos.	16Nos.

All dimensions are in mm

TPN Phase Segregated Distribution Boards



Metal DBs for Three Phase and Neutral (TPN) supply distribution with total phase segregation

Technical Data

- As per IS 8623
- No. of modules – 4, 6, 8, 12 way
- Mounting – Surface / Flush mounting
- IP category
 - IP 30 for single door
 - IP 43/54 for double door
- Material – CRCA sheet steel
- Colour – RAL 9003, powder-coated

Features and Benefits

- Total phase segregation between I/C, sub I/C & O/G
- Equipped with colour-coded wires set
- 100A tin-plated insulated copper busbar
- MCCB incomer version also available
- Cement spill protector in double door DBs
- Door earthing in double door DBs
- Removable gland plates and front plate
- Insulated neutral bar
- Cable ties, blank plates and circuit identification labels
- Plastic inserts on corners for modern looks and corner protection

TPN Phase Segregated Distribution Boards

Description	No. of Modules	Cat. Nos.
IP 30-Single Door (Modular incomer)		
4 way	8+12+12	LTPSC04N
6 way	8+12+18	LTPSC06N
8 way	8+12+24	LTPSC08N
12 way	8+12+36	LTPSC12N
IP 43-Double Door : Plain (Modular incomer)		
4 way	8+12+12	LTPSD04N
6 way	8+12+18	LTPSD06N
8 way	8+12+24	LTPSD08N
12 way	8+12+36	LTPSD12N
IP 43-Double Door :Plain (MCCB incomer)		
4 way	MCCB+12+12	LTPSD04MN
6 way	MCCB+12+18	LTPSD06MN
8 way	MCCB+12+24	LTPSD08MN
12 way	MCCB+12+36	LTPSD12MN

- Also available with IP54
- Provision to mount MCCB type DH 3P up to 125A

Dimensions

IP30 Single Door (Modular I/C)

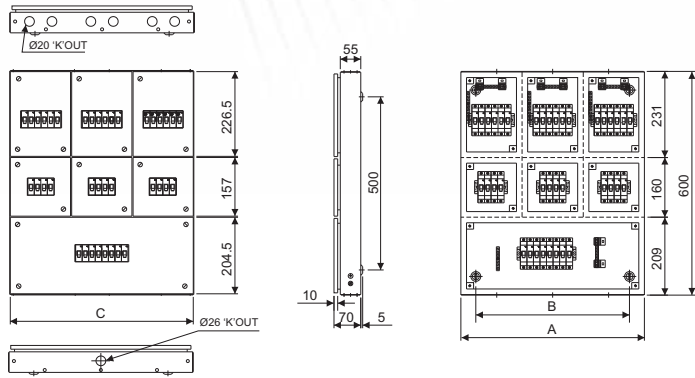

IP43 Double Door – Metal Door (Modular I/C)

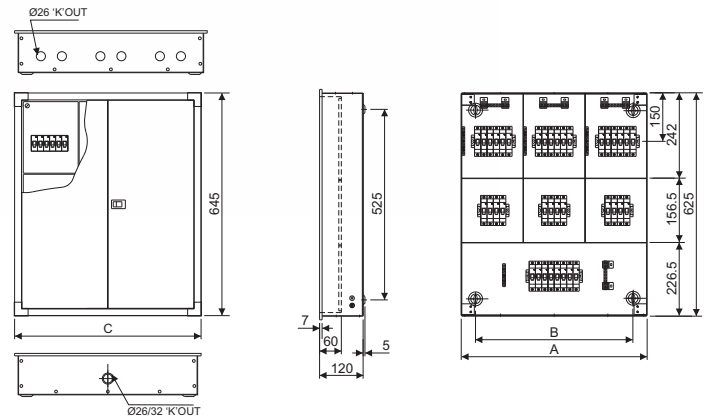

Way	I/C	A	B	C	Ø20, 'K'OUT	
					Top	Bottom
4	8P	384	304	381	6Nos.	1Nos.
6	8P	492	412	489	6Nos.	1Nos.
8	8P	600	520	597	9Nos.	1Nos.
12	8P	816	736	813	12Nos.	1Nos.

Way	I/C	A	B	C	Ø26, 'K'OUT	
					Top	Bottom
4	8P	410	330	430	6Nos.	1Nos.
6	8P	520	440	540	6Nos.	1Nos.
8	8P	630	550	650	9Nos.	1Nos.
12	8P	845	765	865	12Nos.	1Nos.

IP43 Double Door – Metal Door (MCCB I/C)

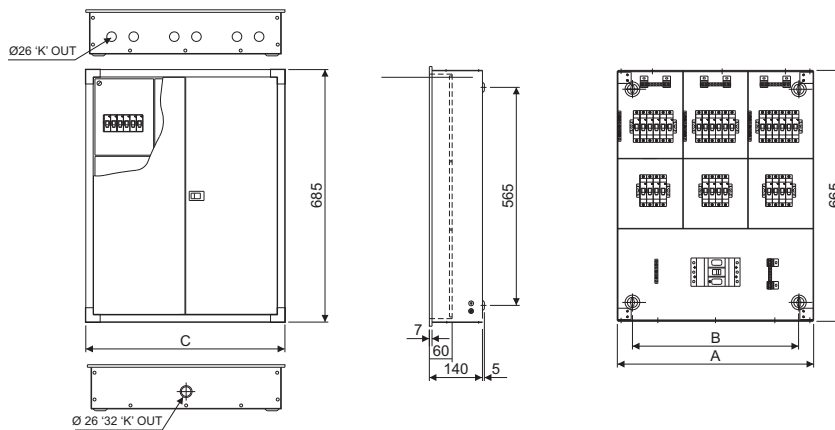

Way	I/C	A	B	C	Ø20, 'K'OUT	
					Top	Bottom
4	MCCB	410	330	430	6Nos.	1Nos.
6	MCCB	520	440	540	6Nos.	1Nos.
8	MCCB	630	550	650	9Nos.	1Nos.
12	MCCB	845	765	865	12Nos.	1Nos.

All dimensions are in mm

TPN Phase Selector Distribution Boards



Metal DBs for Three Phase and Neutral (TPN) supply distribution with selector switches for phase selection

Technical Data

- As per IS 8623
- No. of modules – 4, 6, 8, 12 way
- Mounting – Surface / Flush mounting
- IP category
 - IP 30 for single door
 - IP 43/54 for double door
- Material – CRCA sheet steel
- Colour – RAL 9003, powder-coated

Features and Benefits

- Equipped with 3 nos. 63A Salzer rotary switches
- Equipped with colour-coded wire set
- 100A tin-plated insulated copper busbar
- Cement spill protector in double door DBs
- Door earthing in double-door DBs
- Removable gland plates and front plate
- Insulated neutral bar
- Cables ties, blank plates and circuit identification labels
- Plastics inserts on corners for modern looks and corner protection

TPN Phase Selector Distribution Boards

Description	No. of Modules	Cat. Nos.
IP 30-Single Door		
4 way	8+12	LTPCC04NS
6 way	8+18	LTPCC06NS
8 way	8+24	LTPCC08NS
12 way	8+36	LTPCC12NS
IP 43-Double Door : Plain		
4 way with single front plate	6+12	LTPCD04NES
4 way	8+12	LTPCD04NS
6 way	8+18	LTPCD06NS
8 way	8+24	LTPCD08NS
12 way	8+36	LTPCD12NS

Dimensions

IP30 Single Door

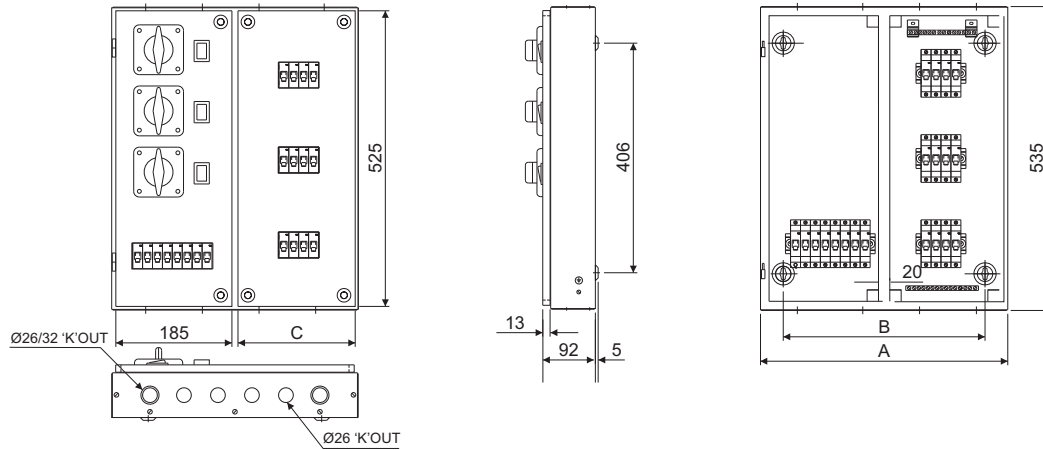

Way	I/C	A	B	C	Top/Bottom	
					Ø26 'K'OUT	Ø26/32 'K'OUT
4	8P	435	355	235	8Nos.	4Nos.
6	8P	470	390	270	10Nos.	4Nos.
8	8P	505	425	305	12Nos.	4Nos.
12	8P	580	500	380	14Nos.	4Nos.

IP43 Double Door – Metal Door

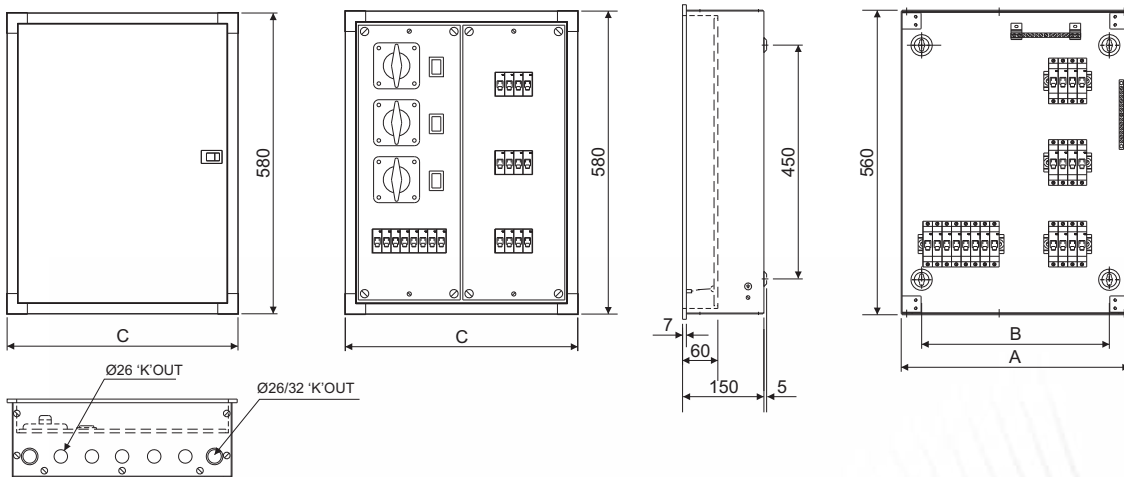

Way	I/C	A	B	C	Top/Bottom	
					Ø26 'K'OUT	Ø26/32 'K'OUT
4	8P	420	350	440	8Nos.	4Nos.
6	8P	455	385	475	10Nos.	4Nos.
8	8P	490	420	510	10Nos.	4Nos.
12	8P	560	490	580	14Nos.	4Nos.

All dimensions are in mm

Flexi Distribution Boards



Metal DBs with flexibility to mount incoming and outgoing as per requirement

Technical Data

- As per IS 8623
- No. of rows : 2, 3 and 4 rows
- No. of modules : 28, 42, 56 way
- Mounting – Surface / Flush mounting
- IP category – IP 43/54 for double door
- Material – CRCA sheet steel
- Colour – RAL 9003, powder-coated

Features and Benefits

- Cement spill protector
- Door earthing in double door DBs
- Choice of plain or glazed door
- Removable gland plates and front plate
- Insulated neutral bar
- Plastic inserts on corners for modern looks and corner protection

Flexi Distribution Boards

Description	No. of Modules	Cat. Nos.
IP 43-Double Door : Plain		
2 row 28 module	28	LTFD228N
3 row 42 module	42	LTFD342N
4 row 56 module	56	LTFD456N
IP 43-Double Door : Glazed		
2 row 28 module	28	LTFD228GN
3 row 42 module	42	LTFD342GN
4 row 56 module	56	LTFD456GN

Dimensions

IP43 Double Door – Metal Door

IP43 Double Door – Glazed Door

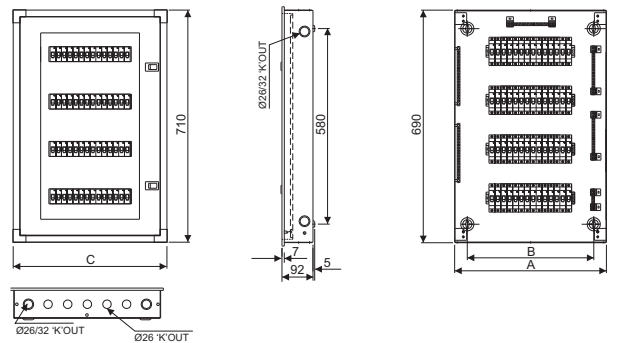
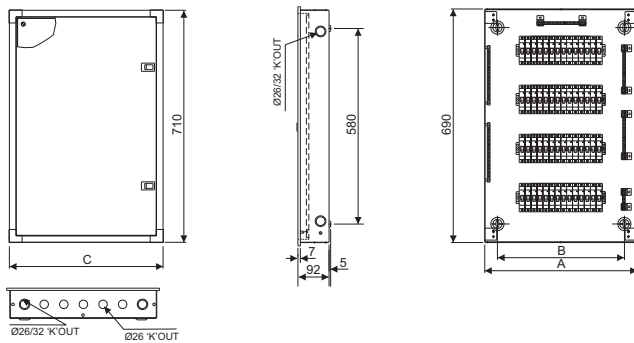
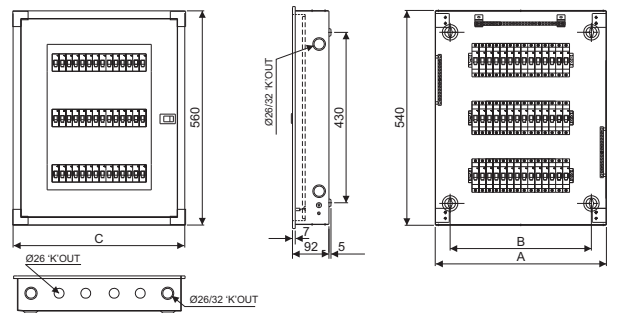
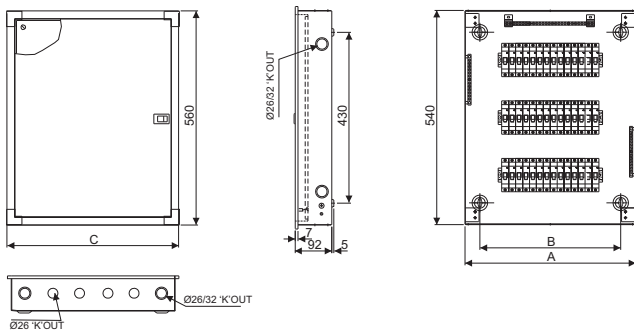
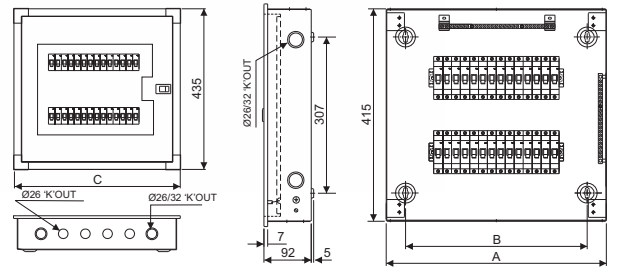
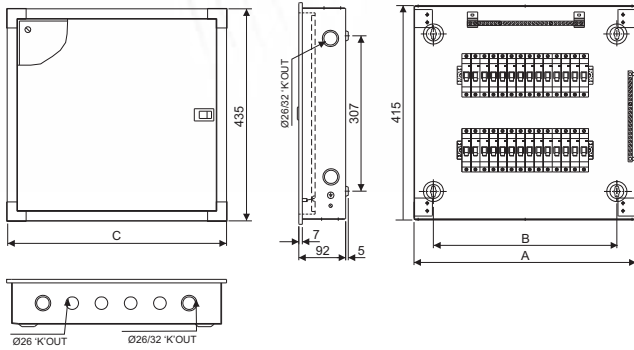

				Top/Bottom	Top/Bottom	Side 'K'OUT
Module	A	B	C	Ø26 'K'OUT	Ø26/32 'K'OUT	Ø26/32 'K'OUT
28	430	355	450	8Nos.	4Nos.	4Nos.
42	430	355	450	8Nos.	4Nos.	4Nos.
56	450	375	470	10Nos.	4Nos.	4Nos.

				Top/Bottom	Top/Bottom	Side 'K'OUT
Module	A	B	C	Ø26 'K'OUT	Ø26/32 'K'OUT	Ø26/32 'K'OUT
28	430	355	450	8Nos.	4Nos.	4Nos.
42	430	355	450	8Nos.	4Nos.	4Nos.
56	450	375	470	10Nos.	4Nos.	4Nos.

All dimensions are in mm

Enclosures



Metal enclosures for flush and surface mounting

Technical Data

- As per IS 8623
- No. of modules : 2, 4 & 6 modules
- Mounting – Surface / flush
- IP category – IP 30 for single door
- Material – CRCA sheet steel
- Colour – RAL 9003, powder-coated

Features and Benefits

- Compact in size
- Neutral & earth terminals
- Supplied with one blanking plate

Enclosures

Description	No. of Modules	Cat. Nos.
2 way	2	LTMC02N
4 way	4	LTMC04N
6 way	6	LTMC06N

Dimensions

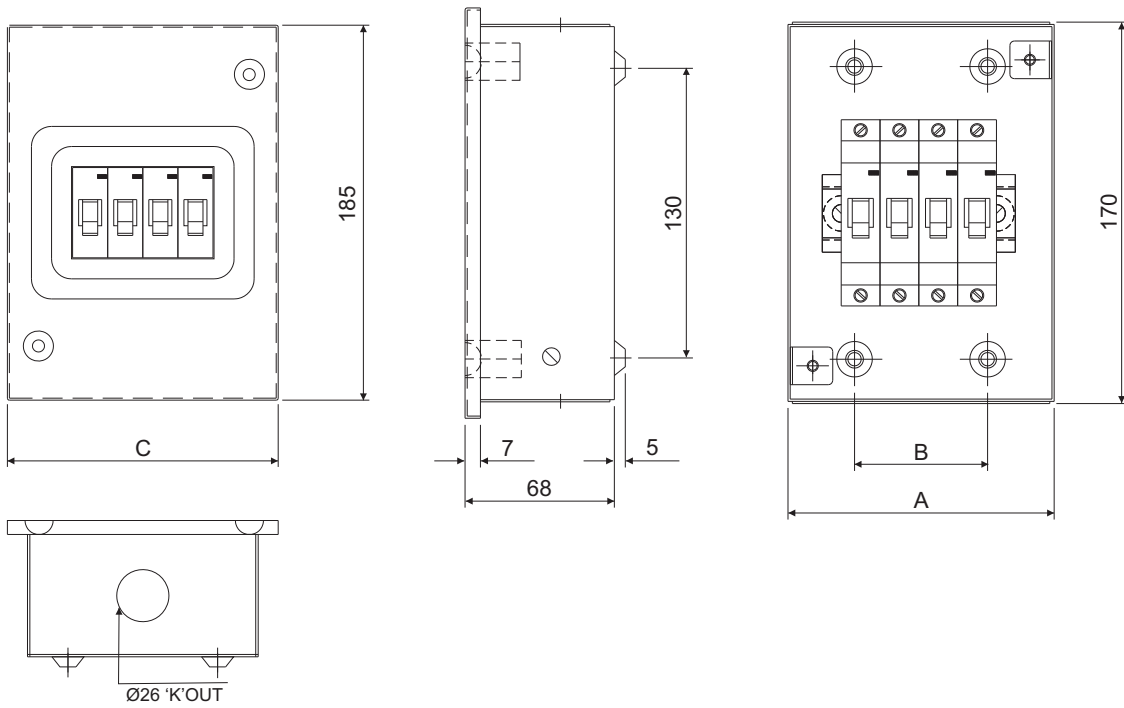

Way	A	B	C	Dia 23 'K'OUT	
				Top	Bottom
2	85	40	100	1No.	1No.
4	120	60	135	1No.	1No.
6	155	95	170	2Nos.	2Nos.

All dimensions are in mm

Plug & Socket Distribution Boards



Insulated / Metal-clad plug & socket outlets for supplying loads

Technical Data

- As per IS 8623
- Rating:
 - SPN – 10A , 20A & 32A
 - TPN – 32A & 63A
- Mounting – Surface / flush mounting
- IP category
 - IP 30 for metal clad unit
 - IP 44 for insulated P&S (IP 30 for enclosure)
- Material – CRCA sheet steel

Features and Benefits

- Compact in size
- Neutral & earth terminals
- Provision to MCBs / RCCBs

Plastic Plug and Socket

Description	No. of Modules	Cat. Nos.
16A 3Pin (P+N+E)	4	LTPP316N
32A 3Pin (P+N+E)	4	LTPP332N
32A 5Pin (3P+N+E)	6	LTPP532N
63A 5Pin (3P+N+E)	8	LTPP563N

Metal Plug and Socket

Description	No. of Modules	Cat. Nos.
10A 2Pin(P+N)+SC*	1	LTMP110N
20A 2Pin(P+N)+SC*	1	LTMP120N
20A 2Pin(P+N)+SC*	2	LTMP220N
20A 3Pin(3P)+SC*	3	LTMP320N
32A 3Pin(3P)+SC*	3	LTMP332N
32A 3Pin(3P)+SC*	4	LTMP432N
63A 5Pin(3P+N+E)+SC*	4	LTMP463N

* SC: Scraping Earth

Dimensions

P&S SP DP

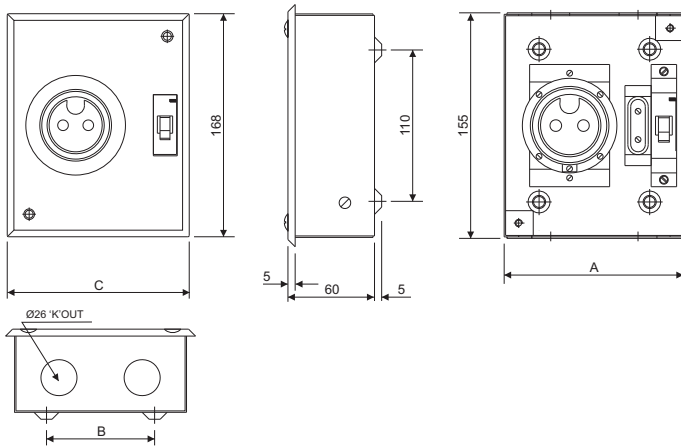

Way	A	B	C	Dia 23 'K'OUT	
				Top	Bottom
1	124	78	137	2Nos.	2Nos.
1	124	78	137	2Nos.	2Nos.
2	124	78	137	2Nos.	2Nos.

Plastic P&S

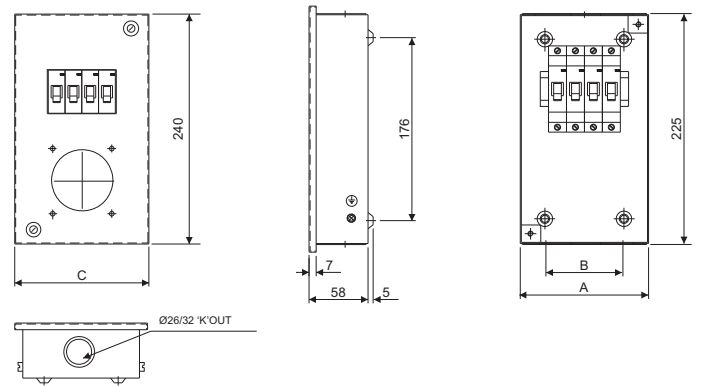

Mode	A	B	C	Dia 26/32 'K'OUT	
				Top	Bottom
4	125	78	140	1No.	1No.
4	125	78	140	1No.	1No.
6	125	65	140	1No.	1No.
8	223	160	220	1No.	--

Metal P&S

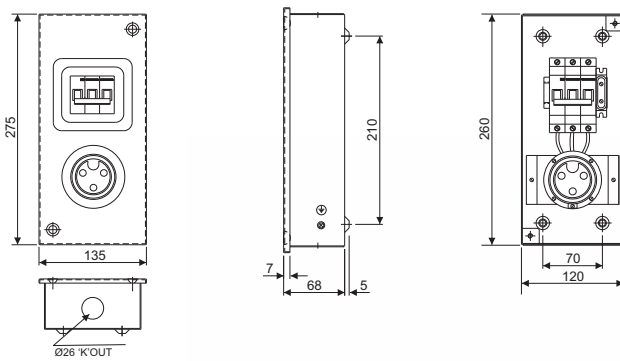

Way	A	B	C	Dia 23 'K'OUT	
				Top	Bottom
1	115	70	130	1No.	1No.
1	115	70	130	1No.	1No.
2	115	70	130	1No.	1No.

IP30 Metal P&S

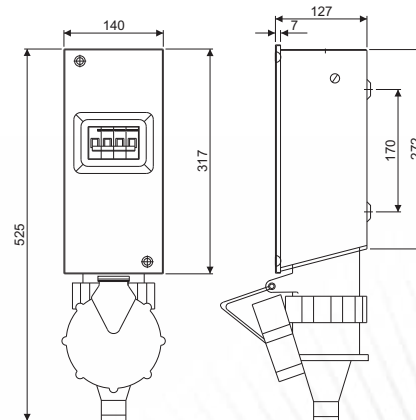

Mode	A	B	C	Dia 26/32 'K'OUT	
				Top	Bottom
4	-	-	-	1No.	--

All dimensions are in mm

Cable End Boxes

To manage loose wires

Technical data

- Material – CRCA sheet steel
- Colour – RAL 9003, powder-coated

Cable End Boxes

Description	Cat. Nos.
CEB for SPN DBs	
CEB for 4 way SPN DD DB	LTSD04CBN
CEB for 6 way SPN DD DB	LTSD06CBN
CEB for 8 way SPN DD DB	LTSD08CBN
CEB for 12 way SPN DD DB	LTSD12CBN
CEB for 16 way SPN DD DB	LTSD16CBN
CEB for 18 way SPN DD DB	LTSD18CBN
CEB for TPN DD DBs	
CEB for 4 way TPN DD ECO DB	LTTD04CBNE
CEB for 4 way TPN DD DB	LTTD04CBN
CEB for 6 way TPN DD DB	LTTD06CBN
CEB for 8 way TPN DD DB	LTTD08CBN
CEB for 12 way TPN DD DB	LTTD12CBN
CEB for 16 way TPN DD DB	LTTD16CBN
CEB for TPN Horizontal PPI DBs	
CEB for 2 + 4 way Horizontal PPI DD DB	LTHPD04CBN
CEB for 2 + 6 way Horizontal PPI DD DB	LTHPD06CBN

Cable End Boxes

Description	Cat. Nos.
CEB for 2 + 8 way Horizontal PPI DD DB	LTHPD08CBN
CEB for 2 + 12 way Horizontal PPI DD DB	LTHPD12CBN
CEB for TPN Tier PPI DBs	
CEB for 2 + 6 way Tier PPI DD DB	LTPPD06CBN
CEB for 2 + 8 way Tier PPI DD DB	LTPPD08CBN
CEB for 2 + 10 way Tier PPI DD DB	LTPPD10CBN
CEB for 2 + 12 way Tier PPI DD DB	LTPPD12CBN
CEB for 2 + 12 way Tier PPI DD DB (MCCB)	LTPPD12MCBN
CEB for Vertical TPN DBs	
CEB for Vertical DD (Modular I/C)	LTVDXXCBN
CEB for Vertical DD (MCCB I/C)	LTVDXXMCBN
CEB for Flexi DBs	LTFDXXCBN
CEB for Phase Segregated DBs	
CEB for 4 way TPN Modular (I/C) DB	LTPSD04CBN
CEB for 6 way TPN Modular (I/C) DB	LTPSD06CBN
CEB for 8 way TPN Modular (I/C) DB	LTPSD08CBN
CEB for 12 way TPN Modular (I/C) DB	LTPSD12CBN
CEB for 4 way MCCB (I/C) DB	LTPSD04MCBN
CEB for 6 way MCCB (I/C) DB	LTPSD06MCBN
CEB for 8 way MCCB (I/C) DB	LTPSD08MCBN
CEB for 12 way MCCB (I/C) DB	LTPSD12MCBN

Dimensions

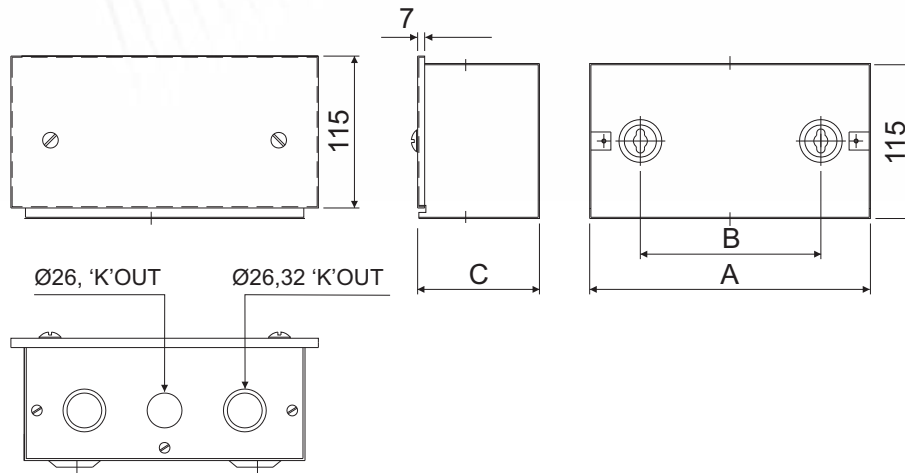

Sr. No.	Way	Type Description	A	B	C
1	4	SPN	140	65	90
2	6		175	100	90
3	8		210	135	90
4	12		285	210	90
5	16		365	290	90
6	4	TPN 4P I/C	280	115	90
7	4	TPN 8P I/C	330	250	90
8	6		370	290	90
9	8		440	360	90
10	12		630	555	90
11	16		775	00	90
12	4+2	Horizontal PPI	375	300	90
13	6+2		470	395	90
14	8+2		540	465	90
15	12+2		682	605	90

Sr. No.	Way	Type Description	A	B	C
16	6+2	Tier PPI	310	235	90
17	8+2		345	270	90
18	10+2		385	310	90
19	12+2		425	350	90
20	12+2	Tier PPI MCCB I/C	425	115	90
21	28	Flexi	430	355	90
22	42		430	350	90
23	56		450	375	90
24	4	VTPN MCB I/C	450	350	90
25	4	VTPN MCCB I/C	450	350	118
26	4	7 COMP MCB I/C	410	330	118
27	6	7 COMP MCB I/C	520	440	120
28	8	7 COMP MCB I/C	630	550	120
29	12	7 COMP MCB I/C	845	765	120
30	4	7 COMP MCCB I/C	410	330	140
31	6	7 COMP MCCB I/C	520	440	140
32	8	7 COMP MCCB I/C	630	550	140
33	12	7 COMP MCCB I/C	845	765	140

All dimensions are in mm

MINIATURE CIRCUIT BREAKER



MCB (10kA)

Miniature Circuit Breaker



The MCB is a vital protection device. It is essential in every electrical installation to safeguard both your life and valuable property against short circuit and overload.

Features and Benefits

- Conforms to IS/IEC 60898-1-2003
- Breaking capacity of 10 kA – better protection for cables and equipment
- Tripping curves B, C & D
- Energy limitation Class 3 allows low let-through energy in the system
- Unique patented design gives both label holder and true contact indication facility for individual poles
- Low watt loss – almost 50% of the values prescribed by IEC 60898-1– saves energy
- Trip free mechanism to ensure maximum safety
- Design based on advanced current limiting hammer trip mechanism ensures quick breaking
- No line load bias gives flexibility for incomer supply termination on either sides
- Accessories – wide range of accessories like aux contacts, u/v release and shunt release
- True contact indication – enhanced safety
- This circuit breaker is suitable for DC application, as per IEC 60947-2 : Rated Voltage: 130 V DC (for SP), 250 V DC (for DP)

Terminals suitable
up to 35 sq mm cable



2-position DIN-Rail clip
– ease of installation

Dual Termination



True Contact
Indication –
enhanced safety



Label Holder



IP-20 Finger-proof terminals – eliminate
chances of accidental contact

Technical Specifications – MCB

Specification	IS / IEC 60898
Current Rating	0.5, 1, 2, 3, 4, 6,10,16, 20, 25, 32, 40, 50, 63A
Number of Poles	Single-Pole (SP), Double-Pole (DP), Three-Pole (TP) and Four-Pole (FP)
Electro Thermal Characteristic	B, C and D curve
Breaking Capacity	10 kA
Rated Voltage	240 / 415 V AC
Current Limitation Class	3
Frequency	50 to 60 Hz
Rated Impulse Voltage	4 kV
Minimum Operating Voltage	24 V AC
Degree of Protection	IP 20
Termination	Dual termination on both the sides (Cable and Busbar)
Applied Connection Torque	6 N*m
Permissible Ambient Temp.	- 5° C to + 55° C
Calibration Temperature	30° C
Mechanical Endurance	>100,000 operation
Electrical Endurance	20,000 operation (cos Ø = 0.85 to 0.9) 6A to 32A 10,000 operation (cos Ø = 0.85 to 0.9) for 40A to 63A
Mounting Position	Horizontal/Vertical/Flat
Mounting	Snap fixing on standard profile 35 X 7.5mm DIN-Rail as per EN 50022

Dimensions

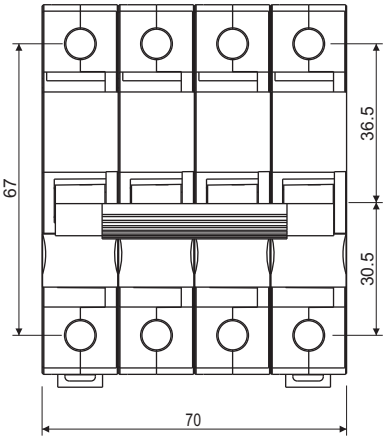
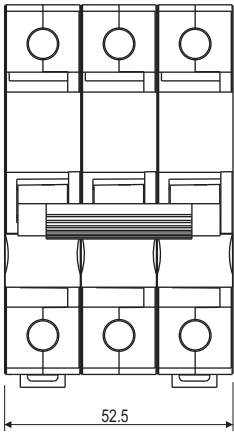
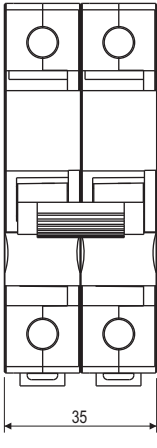
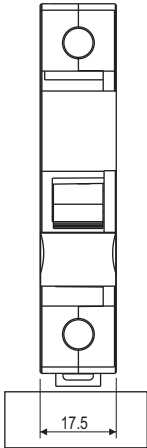
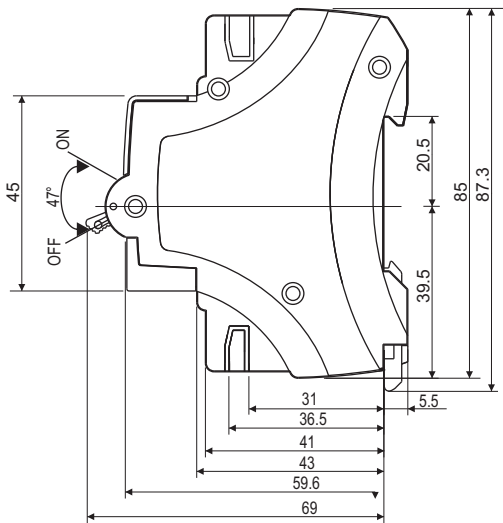

All dimensions are in mm

Single-Pole (SP)



Current Rating (In)	Modules 1 Mod= 17.5mm	B-Curve Cat. Nos.	C-Curve Cat. Nos.	D-Curve Cat. Nos.
0.5A	1	-	BB10E50C	BB10E50D
1A	1	-	BB10010C	BB10010D
2A	1	-	BB10020C	BB10020D
3A	1	-	BB10030C	BB10030D
4A	1	-	BB10040C	BB10040D
6A	1	BB10060B	BB10060C	BB10060D
10A	1	BB10100B	BB10100C	BB10100D
16A	1	BB10160B	BB10160C	BB10160D
20A	1	BB10200B	BB10200C	BB10200D
25A	1	BB10250B	BB10250C	BB10250D
32A	1	BB10320B	BB10320C	BB10320D
40A	1	BB10400B	BB10400C	BB10400D
50A	1	BB10500B	BB10500C	*
63A	1	BB10630B	BB10630C	*

Double-Pole (DP)



Current Rating (In)	Modules 1 Mod= 17.5mm	B-Curve Cat. Nos.	C-Curve Cat. Nos.	D-Curve Cat. Nos.
0.5A	2	-	BB20E50C	BB20E50D
1A	2	-	BB20010C	BB20010D
2A	2	-	BB20020C	BB20020D
3A	2	-	BB20030C	BB20030D
4A	2	-	BB20040C	BB20040D
6A	2	BB20060B	BB20060C	BB20060D
10A	2	BB20100B	BB20100C	BB20100D
16A	2	BB20160B	BB20160C	BB20160D
20A	2	BB20200B	BB20200C	BB20200D
25A	2	BB20250B	BB20250C	BB20250D
32A	2	BB20320B	BB20320C	BB20320D
40A	2	BB20400B	BB20400C	BB20400D
50A	2	BB20500B	BB20500C	*
63A	2	BB20630B	BB20630C	*

* Available on request

Triple-Pole (TP)



Current Rating (In)	Modules 1 Mod= 17.5mm	B-Curve Cat. Nos.	C-Curve Cat. Nos.	D-Curve Cat. Nos.
0.5A	3	-	BB30E50C	BB30E50D
1A	3	-	BB30010C	BB30010D
2A	3	-	BB30020C	BB30020D
3A	3	-	BB30030C	BB30030D
4A	3	-	BB30040C	BB30040D
6A	3	BB30060B	BB30060C	BB30060D
10A	3	BB30100B	BB30100C	BB30100D
16A	3	BB30160B	BB30160C	BB30160D
20A	3	BB30200B	BB30200C	BB30200D
25A	3	BB30250B	BB30250C	BB30250D
32A	3	BB30320B	BB30320C	BB30320D
40A	3	BB30400B	BB30400C	BB30400D
50A	3	BB30500B	BB30500C	*
63A	3	BB30630B	BB30630C	*

Four-Pole (FP)



Current Rating (In)	Modules 1 Mod= 17.5mm	B-Curve Cat. Nos.	C-Curve Cat. Nos.	D-Curve Cat. Nos.
0.5A	4	-	BB40E50C	BB40E50D
1A	4	-	BB40010C	BB40010D
2A	4	-	BB40020C	BB40020D
3A	4	-	BB40030C	BB40030D
4A	4	-	BB40040C	BB40040D
6A	4	BB40060B	BB40060C	BB40060D
10A	4	BB40100B	BB40100C	BB40100D
16A	4	BB40160B	BB40160C	BB40160D
20A	4	BB40200B	BB40200C	BB40200D
25A	4	BB40250B	BB40250C	BB40250D
32A	4	BB40320B	BB40320C	BB40320D
40A	4	BB40400B	BB40400C	BB40400D
50A	4	BB40500B	BB40500C	*
63A	4	BB40630B	BB40630C	*

* Available on request

Auxiliaries and Accessories

10 kA MCBs



L&T MCBs can be fitted with a wide range of accessories like the auxiliary contact, shunt and under voltage release.

Auxiliary & Accessories for 10kA MCBs

Description	Cat. Nos.
Auxiliary Contact – 6A (1NO+1NC), 1/2 module	BZA11006
Shunt Release – 240V AC, 1 module	BZS00240
Trip Alarm Contact - 240V AC, (1NO + 1NC), 1/2 module	BZT11006

RESIDUAL CURRENT DEVICES



RCCB

Residual Current Circuit Breaker



Residual Current Circuit Breakers provide protection against earth leakage fault. They ensure safety of human life in case of earth leakage fault and protection against electric shock.

Features and Benefits

- Conforms to IS 12640-(Part 1), IEC 61008-1
- Short circuit withstand capacity 10kA
- L&T RCCBs are available in DP and FP versions from 25A to 100A ratings with 30mA, 100mA and 300mA sensitivity
- Truly current operated – operation even at low voltage
- Operates on Core Balance Current Transformer (CBCT) principle
- Neutral advance mechanism ensures complete protection
- Finger-proof terminal (IP20)
- Bi-connecting terminals

Protection Devices – RCCB



Finger-proof terminal – IP 20



Dual Termination – suitable for Busbar and / or wire up to 50 sq mm



Test button – Facilitates to check healthiness of device by creating an artificial electrical fault



Combi-head screws – allows use of standard as well as Philips head screwdriver

Technical Specifications – RCCB

Specification	IS 12640 – Part 1 / IEC 61008-1
RCCB Type	AC
Rated Current (I _n) – Amp	25, 40, 63, 100
Operating Sensitivity – mA	30, 100, 300
No. of Poles	2 and 4 Pole
Rated Voltage – 2 Pole	240 V AC
Rated Voltage – 4 Pole	240/415 V AC
Rated Frequency	50/60 Hz
Rated Insulation Voltage	600 V
Rated Impulse Withstand Voltage	4kV
Rated Conditional Short Circuit Capacity	10 kA
Degree of Protection	IP 20
Terminal Capacity	50 sq. mm
Termination	Dual termination (cable and busbar)
Operating Temperature	-5°C to + 55°C
Mounting Arrangement	Snap-fit on 35 mm Din-Rail

Dimensions

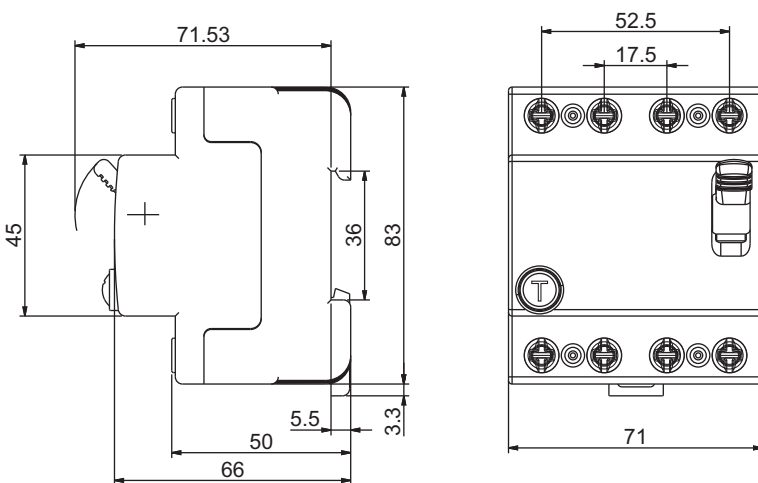
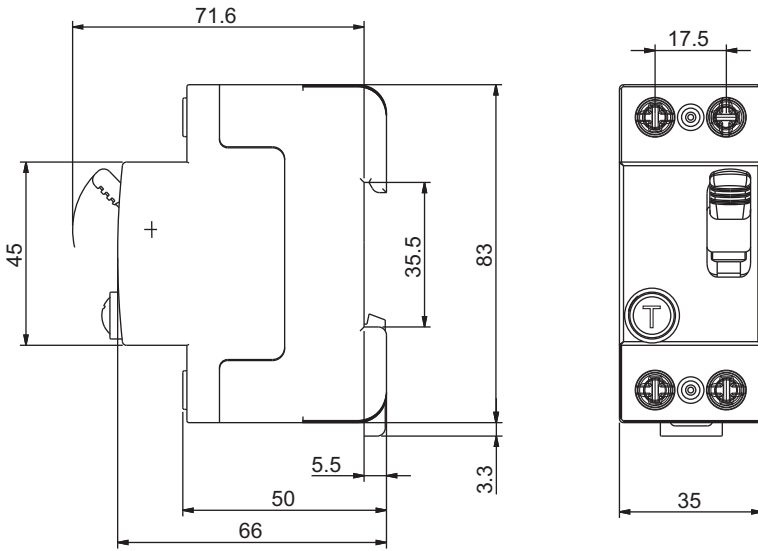

All dimensions are in mm

Current Rating (In)	Sensitivity	Modules 1 Mod= 17.5mm	Cat Nos.
25A	30mA	2	BG202503
	100mA	2	BG202510
	300mA	2	BG202530
40A	30mA	2	BG204003
	100mA	2	BG204010
	300mA	2	BG204030
63A	30mA	2	BG206303
	100mA	2	BG206310
	300mA	2	BG206330
100A	30mA	2	BG210003
	100mA	2	BG210010
	300mA	2	BG210030

Double-Pole (DP)



Current Rating (In)	Sensitivity	Modules 1 Mod= 17.5mm	Cat Nos.
25A	30mA	4	BG402503
	100mA	4	BG402510
	300mA	4	BG402530
40A	30mA	4	BG404003
	100mA	4	BG404010
	300mA	4	BG404030
63A	30mA	4	BG406303
	100mA	4	BG406310
	300mA	4	BG406330
100A	30mA	4	BG410003
	100mA	4	BG410010
	300mA	4	BG410030

Four-Pole (FP)



ISOLATORS



ISOLATORS



Isolators are used in electrical installations to make, carry and break circuit current. The Isolator ensures that the circuit remains completely de-energised i.e. there will be no current at the load side even if the impulse voltage appears when the isolator is OFF.

Features and Benefits

- Conforms to EN/IEC 60947-3
- Suitable for AC22-A utilization category
- Available in DP, TP and FP versions in 40A, 63A, 80A and 100A ratings
- Easy mounting due to two-position DIN-Rail clip
- Combi-head screws – allows use of multiple screwdrivers
- True contact indication – enhances safety
- CE and KEMA certified

Terminals suitable up to 35 sq mm cable and dual termination



2 position DIN-Rail clip – ease of installation



True Contact Indication – enhanced safety



IP-20 Finger-proof terminals – eliminate chances of accidental contact

Technical Specifications – ISOLATORS

Specification	EN / IEC 60947 – 3
Rated Current (In)	40A, 63A, 80A, 100A
No. of Poles	2, 3 and 4
No. of Modules	2, 3 and 4
Rated Operational Voltage (AC)	240/415 V
Rated Frequency	50 Hz
Rated Insulation Voltage	500 V
Rated Impulse Voltage	4 kV
Short Time withstand Capacity	80A - 960A / 1 Sec, 100A - 1200A / 1 Sec
Utilization Category	AC 22A
Degree of Protection	IP 20
Terminal Capacity	35 sq. mm
Operating Temperature	-5°C to + 50°C
Mounting Arrangement	Snap-fit on 35 mm DIN rail
Rated Short Time Withstand Current	1.2kA, 1 sec

Dimensions

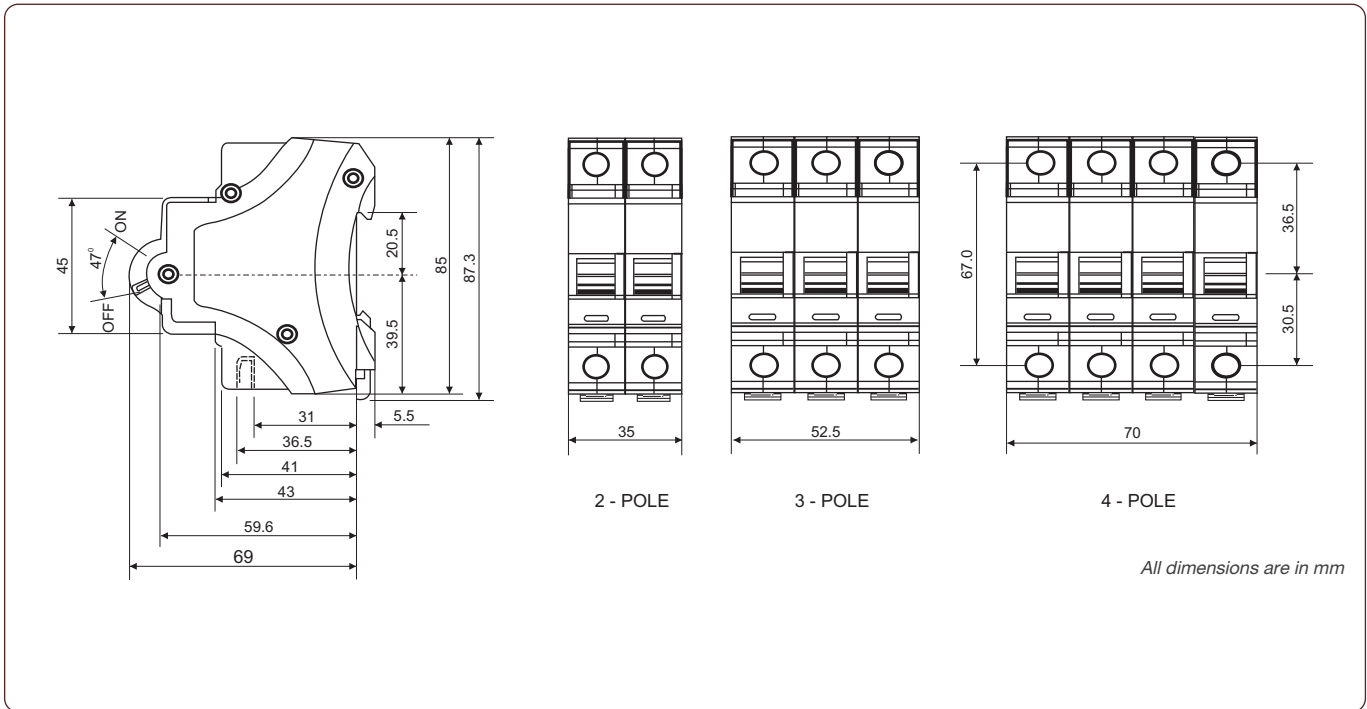

Double Pole (DP)



Current Rating (In)	Modules 1Mod = 17.5mm	Cat. Nos
40	2	BF204000
63	2	BF206300
80	2	BF208000
100	2	BF210000

Current Rating (In)	Modules 1Mod = 17.5mm	Cat. Nos.
40	3	BF304000
63	3	BF306300
80	3	BF308000
100	3	BF310000

Triple Pole (TP)



Four Pole (FP)



Current Rating (In)	Modules 1Mod = 17.5mm	Cat. Nos.
40	4	BF404000
63	4	BF406300
80	4	BF408000
100	4	BF410000

OTHER PROTECTION & CONTROL DEVICES



Indicators



Modular indicator gives indication of status of supply in electrical networks

Features and Benefits

- Modular design, fits on DIN channel
- Very low power consumption
- LED technology, long life
- 3-in-1 Indicator

Technical Specifications

Specification	
Supply Voltage	240V AC
Power Consumption	1.8W
Frequency	50/60Hz
Operating Temperature	-10°C to +55°C
Ingress Protection	IP 20

Dimensions

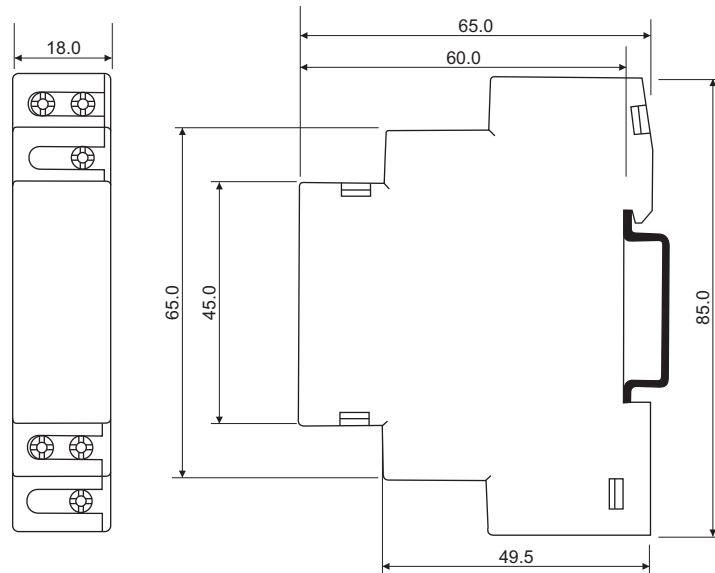

Ordering Information

Description	Cat. Nos.
Red – Single phase indicator	MM1NDV04
Yellow – Single phase indicator	MM1NDW04
Blue – Single phase indicator	MM1NDX04
Red , Yellow & Blue – Three phase indicator	MM3ND04

Energy Meter

DIN Rail Meters



mi-Energy TM is L&T's DIN-Rail mounted meter. Available in 3 phase and 1 phase models, these meters can be mounted inside distribution boxes to monitor electric consumption of identified loads, circuits and areas.

Features and Benefits

- LCD display
- Class 2 accuracy
- Displays day, week, month and push-to-push kWh consumption
- Push button for parameter scrolling
- Low starting current
- Reverse current indication*
- Compact size and easy mounting

*for 3-phase meter

Technical Specifications

Display	Type	6 digit LCD
	Height	6 mm (10mm in case of 3-Phase meter)
Measuring Circuit	Class of accuracy	Class 2 as per IEC 62053-21
	Measurement circuit burden	<1W, <8VA
	Rated Voltage	240 V
	Current	3-phase: 10-60A 1-phase: 5-30A
	Starting current	3-phase: 40mA 1-phase: 20mA
	Voltage range for class of accuracy	-30% to +20% of rated voltage
	Current range for class of accuracy	5% I _b to I _{max}
	Input frequency range	50Hz ±5%
	Insulation Properties	Impulse voltage test
AC voltage test		4kV double insulation as per IEC 62053-21
Insulation resistance		500V DC as per IS 13779
Electrical Requirements	Test of power consumption	IEC 62053-21
	Voltage dips and interrupts	IEC 62052-11
	Short time over current protection	20 times of I _{max} for half a second as per IEC 62053-21
Electro-Magnetic Compatibility (EMC)	Fast transients burst test	IEC 61000-4-4
	Immunity to electrostatic discharge	IEC 61000-4-2
	Immunity to electromagnetic HF fields	IEC 61000-4-3
	Immunity to conducted disturbances by RF field	IEC 61000-4-6
	Surge immunity test	±4 kV as per IEC 61000-4-5

Climatic Test	Dry heat test	IS 9000(part 3)
	Cold test	IS 9000(part 2)
	Damp heat cyclic test	IS 9000(part 5)
Operating Conditions	Operating temperature	-10°C to +55°C
	Storage temperature	-20°C to +70°C
Mechanical Tests	Shock	IS 9000 (part 7)

Wiring Diagram

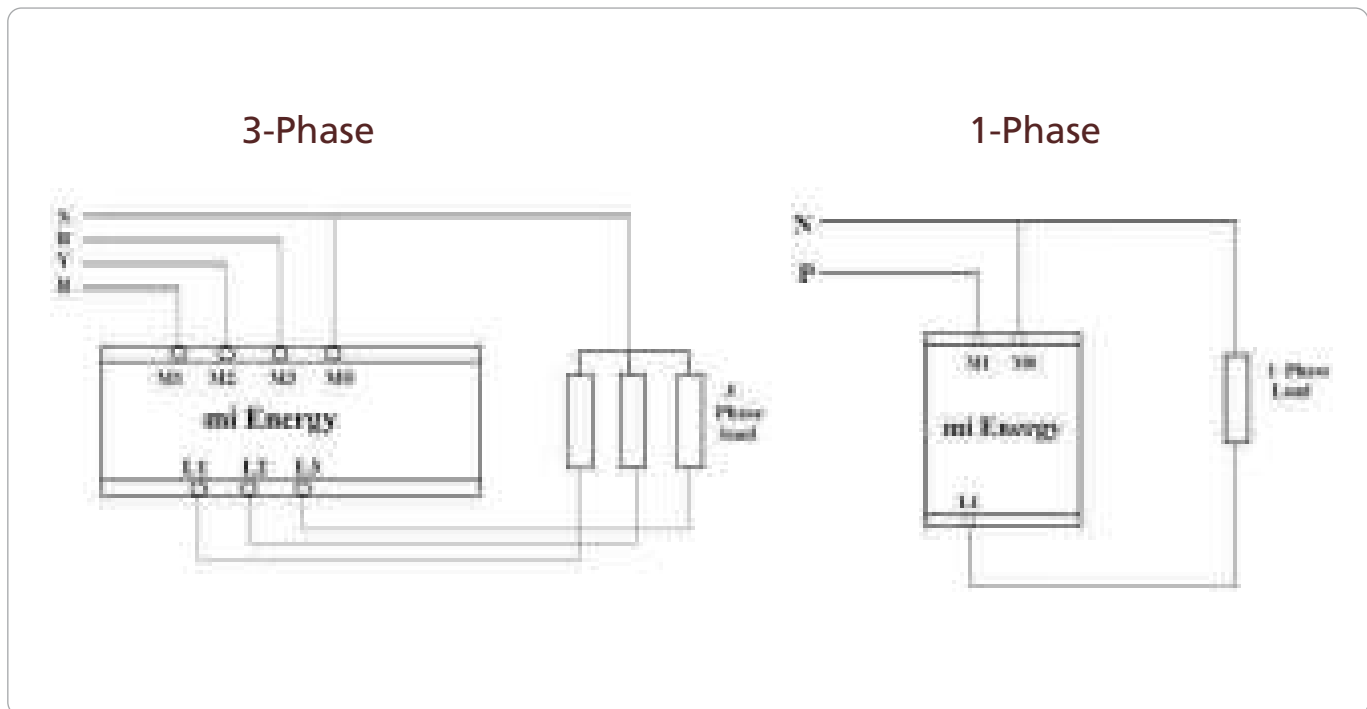

Dimensional Details

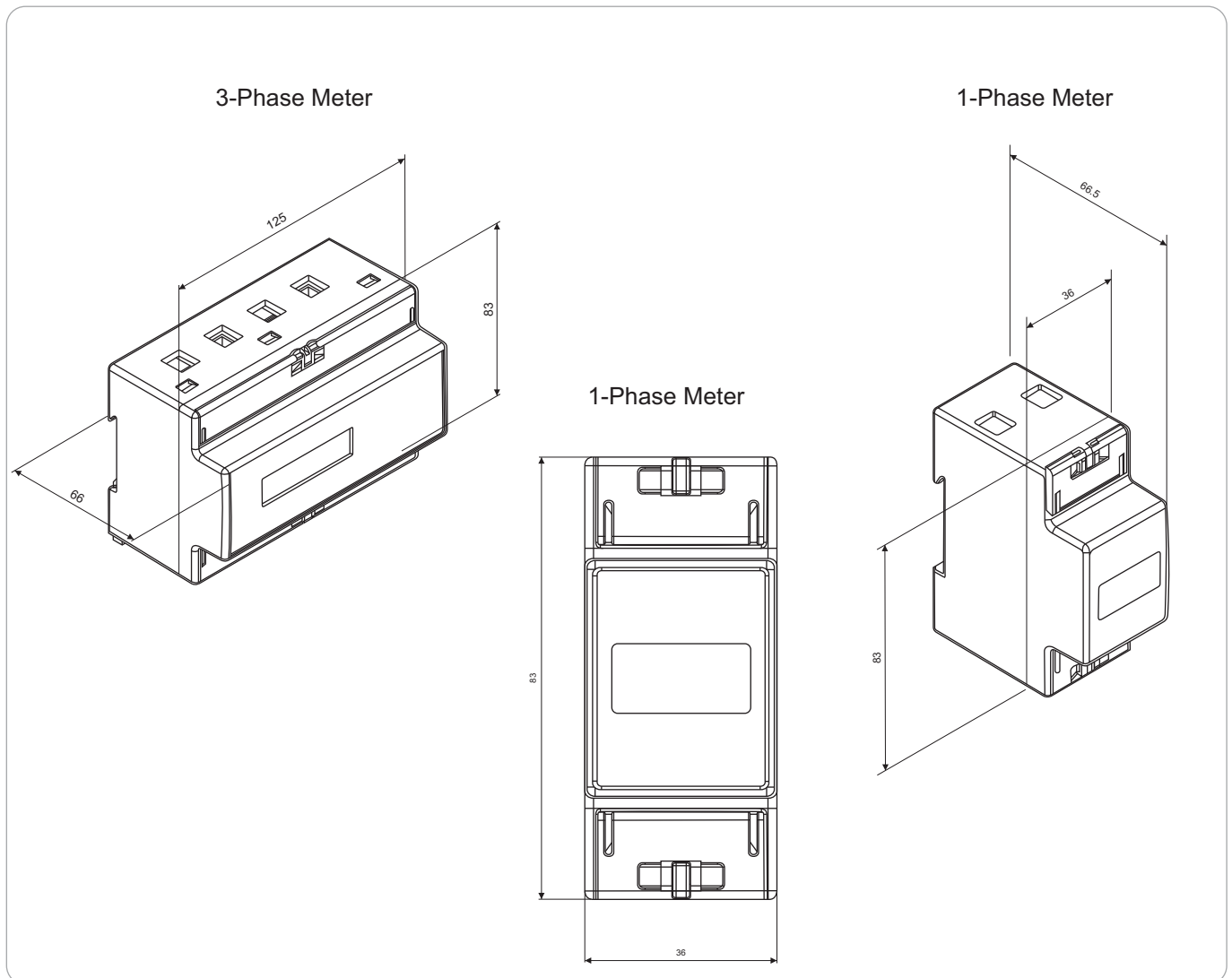

Ordering Information

	Pack Qty.	Cat. No.
3-phase 4-wire 240V 10-60 A	Single	W4DLD100600
	Bulk Pack (20 nos.)	W4DLD10060B
1-phase 2-wire 240V 5-30 A	Single	W2DLD050600
	Bulk Pack (20 nos.)	W2DLD05060B

Analog Time Switch



Time switches are used for fixed time based daily /weekly applications. They are ideal for lighting applications and are also used to control air conditioners / coolers, geysers, pumps and exhaust fans, etc.

Features and Benefits

- Modular construction
- Power reserve up to 150 hrs
- Inbuilt over-ride facility
- 1 NO for 1 module and 1 changeover contact for 3 modules

Technical Specifications

Type	1M	3M
Parameters		
Supply Voltage	230 V AC/110 V DC	230 V AC/130 V DC
Power Consumption	1 VA	
AC Switching Capacity		
Resistive Load	16A/250 V AC	
Inductive Load (Cos PHI=0.6)	4A/250 V AC	
Incandescent Lamp Load	1000W	
Switching Output	Potential-free	
Switch Contacts	1 NO	1C/O
Protection Class	II	
Protection Type	IP 20	
Accuracy	2.5 sec/day at +20°C	
Power Reserve (hours)	50	150
Charging Time (hours)	100	70
Shortest Switching Time		
Day Program (mins.)	30	30
Week Program (mins.)	N A	180
Manual Switch	Automatic/Fixed On	Automatic/Fixed On/Fixed Off
Connection Type	Captive ± Screw Terminals	
Ambient Temperature	-20° to + 55°C	
Sealable	YES	
Dimensions (HXWXD) mm	17.5 X 90 X 60	52.5 X 85 X 65
Distributor Cut-Out (mm)	46 X 18	46 X 54
Weight (g) Approx.	110	170

Dimensions

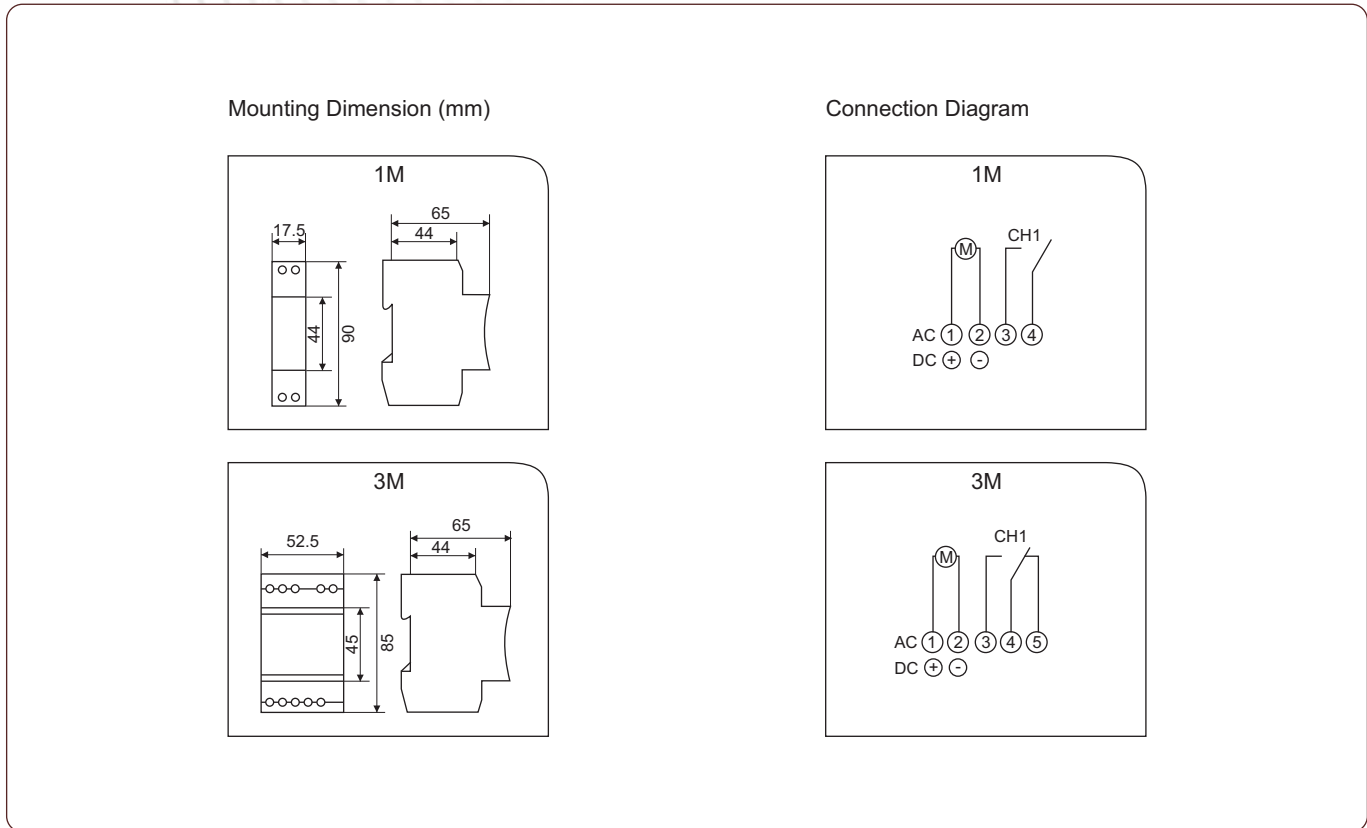

Ordering Information

Description	Cat. Nos.
1 Mod time switch	J6107B204
3 Mod time switch	J6118B304

Digital Time Switch



Digital time switch provides ease and flexibility of programming precisely with battery reserve of 6 years.

Features and Benefits

- Precise time programming for daily/weekly/pulse applications
- 25 ON/OFF programs
- Weekend exclusion and weekly OFF programming
- LED indication for relay status
- 12/24-hour display format
- 6-year battery reserve
- Simple reset and manual override
- Settable DST and keypad lock feature

Technical Specifications

Specification	Crono	Pulse
Voltage Supply	110-240 V AC	
Consumption	6 VA	
Output	1 C/O	
Switching Capacity	16 A(For NO) & 5 A (for NC)	
Accuracy	± 2 sec per day maximum	
Supply failure reserve	6 years	
Manual override	Yes	
Ingress protection	IP20 for terminals, IP 40 for enclosure	
Working temperature	-10°C to +55°C	
Switching time	1min	1sec
LED Indication	Red LED for relay status	
No. of memory locations	25 ON / OFF programs	16 ON programs

Dimensions

Connection Diagrams

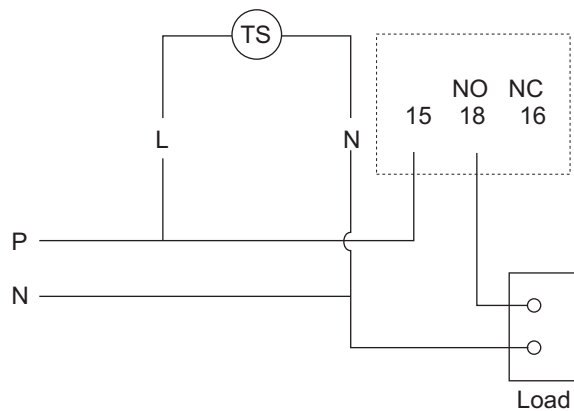

Overall Dimensions

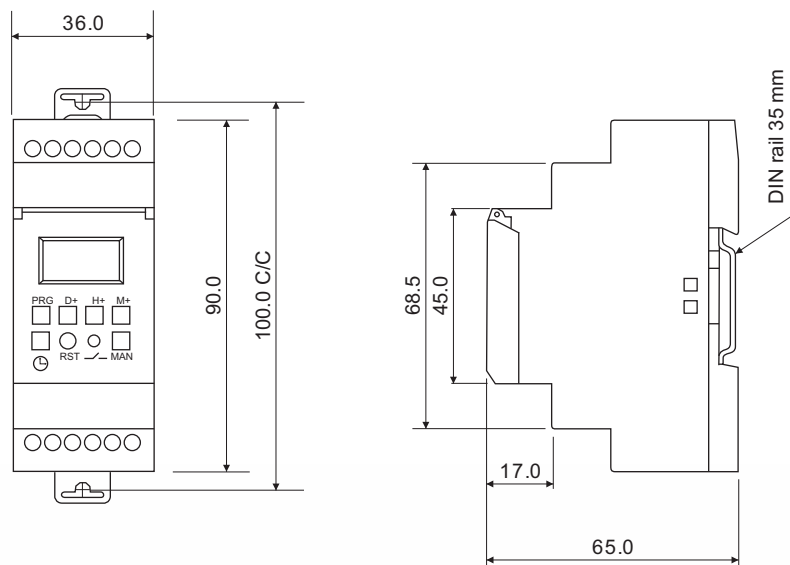

Ordering Information

Description	Cat. No.
Crono time switch, 110 – 240 V AC (50/60 Hz), 1 C/O (SPDT)	67DDT0
Pulse time switch, 110 – 240 V AC (50/60 Hz), 1 C/O (SPDT)	67DDT9

Astronomical Time Switch



L&T time switches with astronomical features are available in two module sizes. They are ideal for street lighting applications with guaranteed energy savings.

Features and Benefits

- Astronomical time switch in 35 mm size
- Latitude / longitude precise to the minute with time zone
- Sunrise / sunset or twilight rise / set trigger modes
- DST, Offset, OFF hours, weekly OFF features
- 12/24-hour display format
- 6-year battery reserve
- Easy manual override
- Ideal for outdoor and street lighting application

Technical Specifications

Specification	
Version	Astro Mini (2 Mod)
Voltage Supply	110-240 V AC
Consumption	6VA
Output	1 C/O
Switching Capacity	16A NO and 5A NC
Accuracy	± 2 sec per day maximum
Supply failure reserve	6 years
Manual override	Yes
Ingress protection	IP20 for terminals, IP 40 for enclosure
Working temperature	-10°C to + 55°C
Modes	Auto ON, Auto OFF, Auto
LED Indication	Red LED for relay status

Dimensions

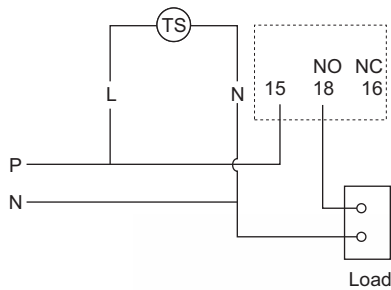

Connection Diagrams

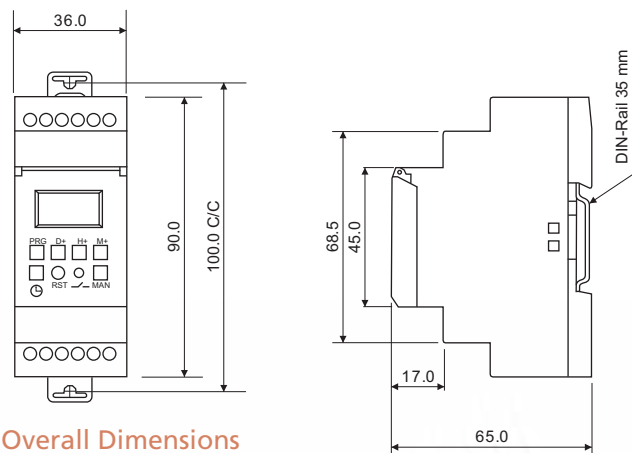

Overall Dimensions

Ordering Information

Description	Cat. Nos.
Astro Mini, 110 – 240 V AC 1 Phase 2 Wire (50/60 Hz), 1 C/O (SPDT)	T2DDT7

SPD

Surge Protection Device



SPD is a device that shields electrical / electronic circuits or equipment from a sudden and destructive increase (surge) in the line voltage caused usually by direct lightning strikes, indirect lightning strikes, or due to faults in house operational devices and other switching.

Features and Benefits

- Visual Life indicator
- Remote monitoring capability
- Response time of less than 25ns
- Available in Type 1+2 & Type 2
 - Type 1+2: Protect against direct & indirect lightning surges
 - Nominal Discharge Current - In 20kA
 - Maximum Discharge Current - I_{max} 50kA
 - Type 2 - Protection against indirect lightning and switching surges
 - Maximum Discharge Current - I_{max} 40kA and 15kA

Technical Specifications

Type - 2	1P+N, 40kA	3P+N, 40kA	1P+N, 15kA	3P+N, 15kA
Specification				
AC Network	230/400V			
Maximum operating voltage U_c	440 Vac			
TOV withstand U_T	770 Vac			
Operating Current I_c	<1 mA			
Nominal Discharge Current I_n 15X 8/20 micro second	20kA	5kA	20kA	5kA
Maximum Discharge Current I_{max} Maximum withstand 8/20 micro second	40kA	15kA	40kA	15kA
Protection Level U_p	1.1kV			
Admissible short circuit current	10000A	10000A	10000A	10000A
Terminal Capacity	L/N 1.5-10 sq mm and 2.5 -25 sqmm (PE)			
Disconnection Indicator	1 mechanical indicator	2 mechanical indicator	2 mechanical indicator	2 mechanical indicator
Mounting	DIN rail mounting			
Operating Temperature	-40° C to 85° C			
Protection Class	IP 20			
Standard Compliance	IEC 61643-11			
Dimension (HxWxD)	90 mm x 18 mm x 67mm	90 mm x 36 mm x 67mm	90 mm x 18 mm x 67mm	90 mm x 36 mm x 67mm

Technical Specifications

Type - 1+2	1P + N	3P + N
Specification		
AC Network	230 / 400V	
Maximum operating voltage U_c	440 Vac	
TOV withstand U_T	770 Vac	
Operating current I_c	<1 mA	
Nominal Discharge current I_n 15X 8/20 micro second	20kA	
Maximum Discharge current I_{max} Maximum withstand 8/20 micro second	50kA	
Max. Lightning current by Pole limp Max withstand at 10/350 micro second	12.5kA	
Protection Level Up	1.7kV	
Admissible short circuit current	25000A	
Terminal Capacity	4-25 Sq mm / bus bar termination	
Disconnection Indicator	1 mechanical indicator	
Mounting	DIN rail mounting	
Operating Temperature	-40° C to 85° C	
Protection Class	IP 20	
Standard Compliance	IEC 61643-11	
Dimension	90 mm x 36 mm x 82mm	90 mm x 72 mm x 82mm

Single-Phase ACCL

Automatic Source Changeover with Current Limiter



A perfect solution for efficient distribution of generator power in high-rise apartments, townships, commercial buildings, etc. ACCL consists of three separate pairs of terminals for connecting two single-phase (240V AC) supplies and a single-phase load. The ACCL will switch the load to generator supply during failure of EB supply. On resumption of EB supply, it will automatically switch from generator to EB supply.

Features and Benefits

- Electronic & mechanical interlock for safe changeover
- Wide range of operation voltage: 140 to 280V AC
- Reliable microcontroller-based design for sensing & control
- Lower consumption - less than 1 watt
- RoHS-compliant

Technical Specifications

Parameters	Unit	Single Phase ACCL
Conformance to Standard		IEC 60947-6-1
No. of Poles		1P+N
Rated current from Mains (In)	A	30
Rated current from Generator (In)	A	1.5 to 10
Rated voltage (Ue)	Vac	230
Rated frequency	Hz	50
Rated insulation voltage	Vac	500
Power consumption	W	1
Changeover time	Seconds	15
Dielectric strength	kV	2
Utilization category		AC 31B
Class of equipment		PC
Environment		B
LED Indication		Mains, Generator & Overload
Electrical endurance	Operations	6000
Rated impulse voltage	kV	1.5
Duty		Uninterrupted
Pollution degree		2
Conditional short circuit breaking capacity	kA	3
IP class		IP20
Mounting		DIN RAIL (35x7.5 mm)
Terminal Capacity sq.mm	Sq. mm	10
Weight	gram	350

Dimensions

Wiring Diagram

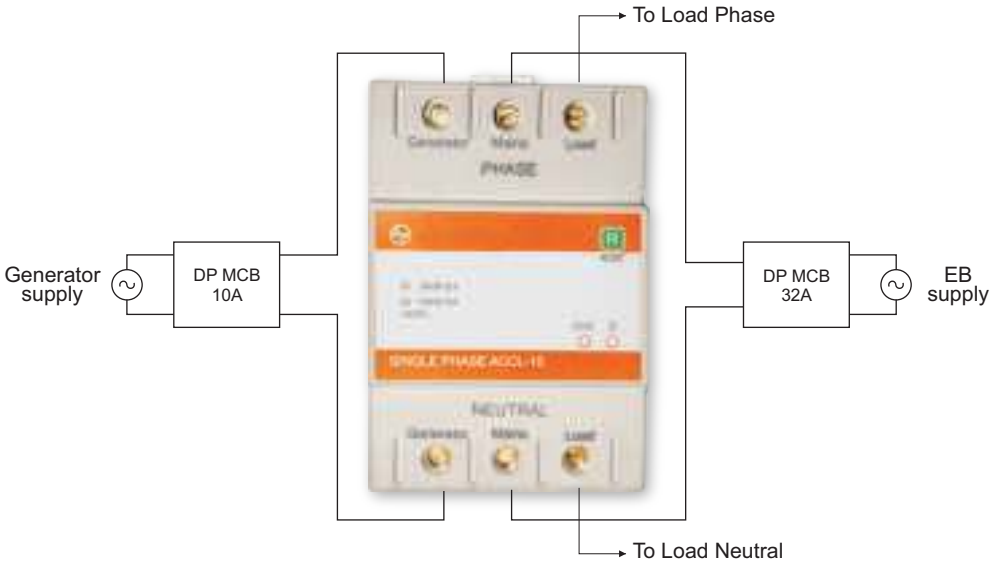

Overall Dimensions

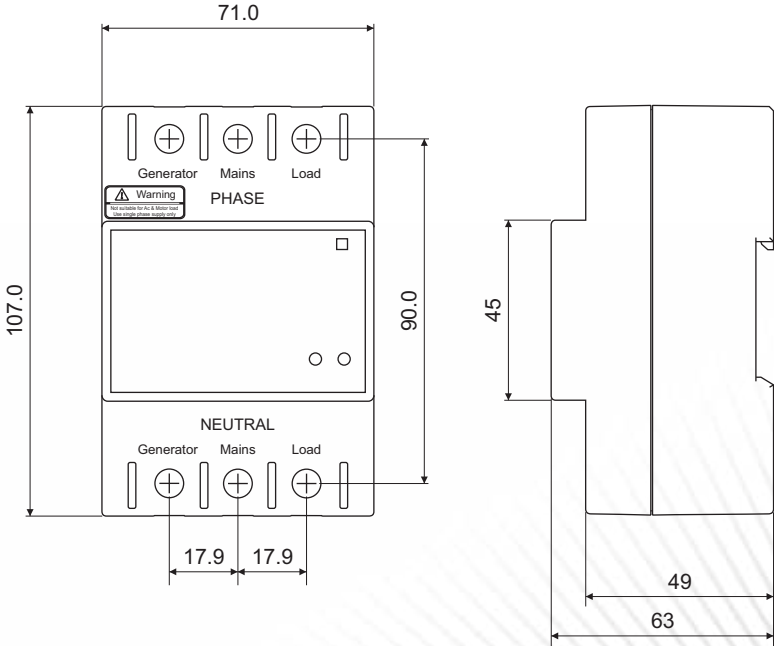

All dimensions in mm

Ordering Information

Cat. No.	Description	Current Rating in Amps.		Recommended MCB Rating	
		EB Current (A)	Gen. Trip Current (A)	EB MCB (A)	Gen. MCB (A)
ACCL113001O	Single-Phase ACCL - 30A/1.5A (300W)	30	1.5	32	2
ACCL113002O	Single-Phase ACCL - 30A/2.5A (500W)	30	2.5	32	3
ACCL113003O	Single-Phase ACCL - 30A/3A (600W)	30	3	32	4
ACCL113004O	Single-Phase ACCL - 30A/4A (800W)	30	4	32	4
ACCL113005O	Single-Phase ACCL - 30A/5A (1000W)	30	5	32	6
ACCL113006O	Single-Phase ACCL - 30A/6A (1200W)	30	6	32	6
ACCL113008O	Single-Phase ACCL - 30A/8A (1600W)	30	8	32	10
ACCL113010O	Single-Phase ACCL - 30A/10A (1800W)	30	10	32	10

Ingress Protection (IP)

The protection of enclosures against ingress of dirt or against the ingress of water is defined in IEC529 (BSEN60529:1991). Conversely, an enclosure which protects equipment against ingress of particles will also protect a person from potential hazards within that enclosure, and this degree of protection is also defined as a standard.

The degrees of protection are most commonly expressed as 'IP' followed by two numbers, e.g. IP65, where the numbers define the degree of protection.

1st Digit Protection against Human Contact/ Protection against Foreign Bodies

- No special protection
- With back of hand / large foreign bodies, diam. >50mm
- With a finger / medium-sized foreign bodies, diam. >12.5mm
- With tools and wires etc. with a thickness >2.5mm / small foreign bodies, diam. >2.5mm
- With tools and wires etc. with a thickness >1mm / granular foreign bodies, diam. >1mm
- Complete protection / dust protected
- Complete protection / dust-proof

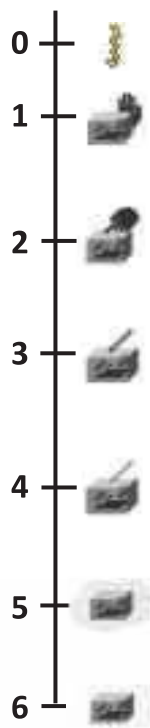

2nd Digit Protection against Water Ingress

- No special protection
- Water dripping vertically
- Water dripping at an angle (up to 15 degrees from the vertical)
- Spray water (any direction up to 60 degrees from the vertical)
- Spray water from all directions
- Water jets from a nozzle in all directions
- High pressure jets
- Temporary immersion
- Permanent immersion

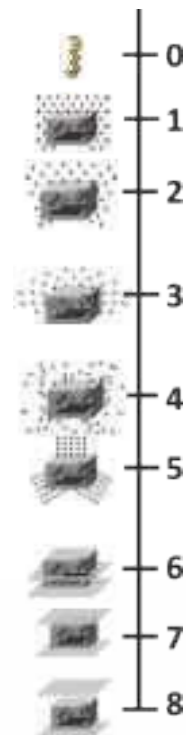

TECHNICAL INDEX

1. Basics of Electrical System and General Electrical Practices

- 1.1 Types of faults
 - 1.2 Safety requirement
-

2. Earthing Systems

- 2.1 Types of Earthing systems
 - 2.2 Comparison of Earthing systems
 - 2.3 Choice of Earthing
-

3. Miniature Circuit Breaker (MCB)

- 3.1 Selection of MCB
 - 3.2 Application of different curves
 - 3.3 Temperature de-rating chart
 - 3.4 I-T characteristics
 - 3.5 Watt loss table
-

4. Residual Current Devices

- 4.1 Danger of electrocution
 - 4.2 Working of residual current devices
 - 4.3 Precautions for installation
 - 4.4 Fault finding when RCCB trips
 - 4.5 I-T characteristics
-

5. Surge Protection Device (SPD)

- 5.1 SPD classification
 - 5.2 Installation and wiring
 - 5.3 SPD selection
-

6. Single Phase ACCL

Basics of Electrical System and General Electrical Practices

Fault

A fault can be defined as any abnormal flow of electric current, in an electric power system.

Types of faults

Faults can be broadly classified into two main areas.

1. Active Fault
2. Passive Fault

1. Active Fault

An 'Active' fault occurs when actual current flows from one phase conductor to another (phase-to-phase) or alternatively from one phase conductor to earth (phase-to-earth). This type of fault can also be further classified into two areas, namely the 'solid' fault and the 'incipient' fault.

Solid fault

The solid fault occurs as a result of an immediate complete breakdown of insulation. For example a pick struck an underground cable, bridging conductors etc.

Incipient fault

An incipient fault is a fault that starts from very small beginnings, say some partial discharge (excessive electronic activity often referred to as corona) in a void in the insulation, increasing and developing over an extended period, until such time as it burns away adjacent insulation, eventually running away and developing into a "solid" fault.

2. Passive Fault

Passive faults are not real faults in the true sense of the word, but are conditions that stress the system beyond its design capacity, so that ultimately active faults will occur. Examples of passive faults Overloading leading to overheating of insulation (deteriorating quality, reduced life and ultimate failure).

Overvoltage – stressing the insulation beyond its limits.
Under frequency – causing plant to behave incorrectly.
Power swings – generators going out-of-step or synchronism with each other.

Safety Requirements

Some of the important safety requirements in electrical installations in domestic dwellings are summarized below:

- a. All outlets for domestic electrical appliances shall be of three-pin socket type, the third socket being connected to the earth.
- b. All the single-pole switches shall be on phase or live conductor only.
- c. The electrical outlets for appliances in the bathrooms shall be away from the shower or sink.
- d. Wiring for power outlets in the kitchen shall be preferably done in metallic conduit wiring.
- e. The electrical outlets shall not be located above the gas stove.
- f. The clearance between the bottom-most point of the ceiling fan and the floor shall be not less than 2.4 m.
- g. The metallic body of the fan regulator if any, shall be earthed effectively.
- h. Earth leakage circuit-breaker at the intake of power supply at the consumer's premises shall be provided.

Earthing

According to BS 7671 five types of earthing are specified.

- TT-Earthing system
- TN-S Earthing system
- TN-C system
- TN-C-S system
- IT-system

In the above systems,

T = Earth (from the French word *Terre*)

N = Neutral

S = Separate

C = Combined

I = Isolated

When designing an electrical installation, one of the first things to determine is the type of earthing system. The system will either be TN-S, TN-C-S Protective Multiple Earthing (PME) or TT for a low voltage supply given in accordance with the Electricity Safety, Quality and Continuity Regulations 2002.

1. TT system – If the neutral of the source & protective earth (PE) conductor at the consumer end are earthed separately, the system is called TT system. The system is as shown in the figure.

With TT, the consumer must provide their own connection to earth, i.e. by installing a suitable earth electrode local to the installation. The circumstances in which a distributor may not provide a means of earthing for the consumer where the distributor cannot guarantee the earth connection back to the source, e.g. a low voltage overhead supply or where there is the likelihood of the earth wire either becoming somehow disconnected or even stolen.

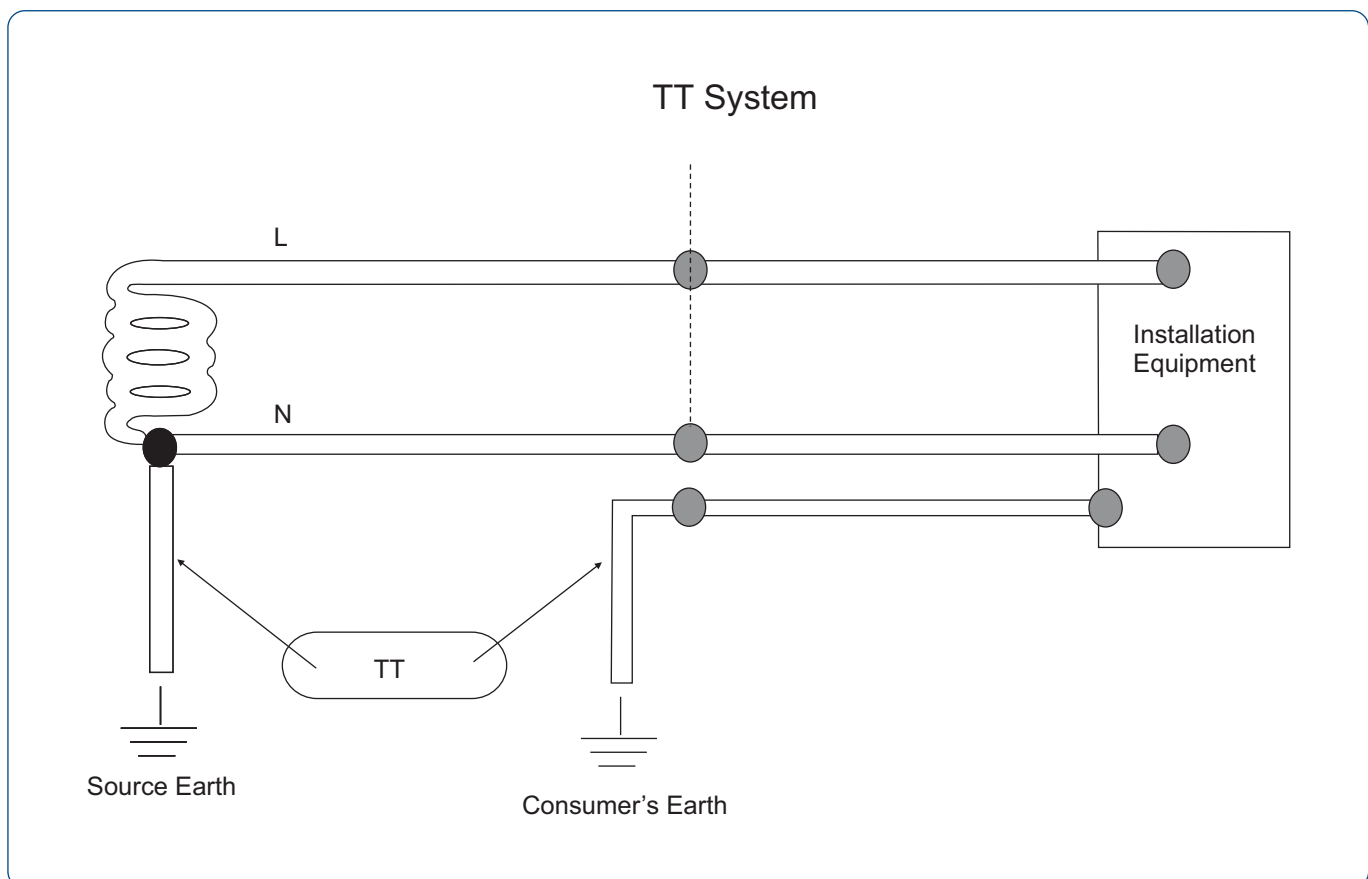

2. TN- S system

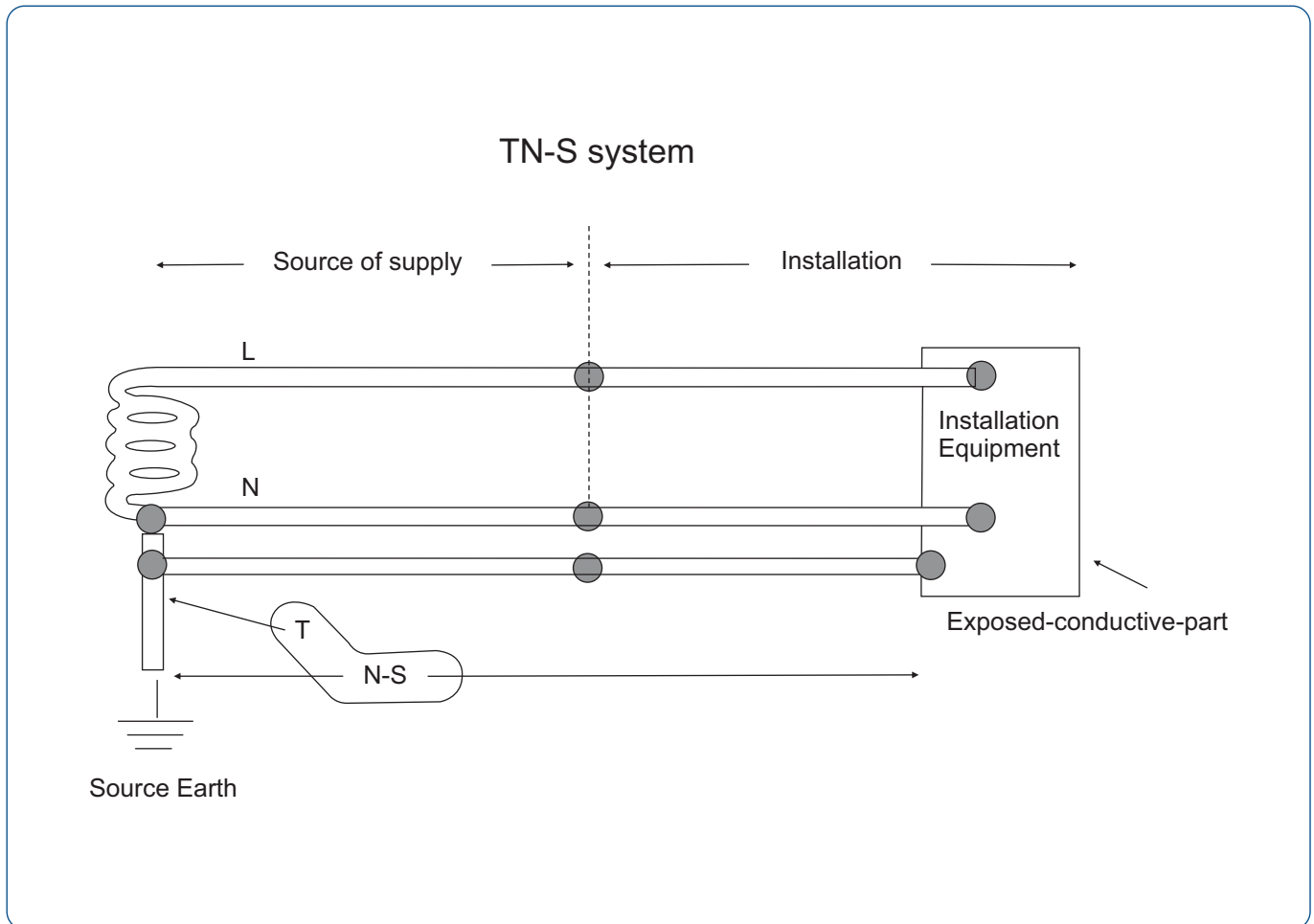

In this system, the N and PE neutral conductors are separate. PE and N conductors are mandatory for the circuits of cross-section less than 10 sq.mm.

A TN-S system has the neutral of the source of energy connected with earth at one point only, at or as near as is reasonably practicable to the source. The consumer's earthing terminal is typically connected to the metallic sheath or armour of the distributor's service cable into the

premises or to a separate protective conductor of, for instance, an overhead supply. Large consumers may have one or more HV/LV transformers dedicated to their installation and installed adjacent to or within their premises. In such situations, the usual form of system earthing is TN-S.

3. TN-C-S system

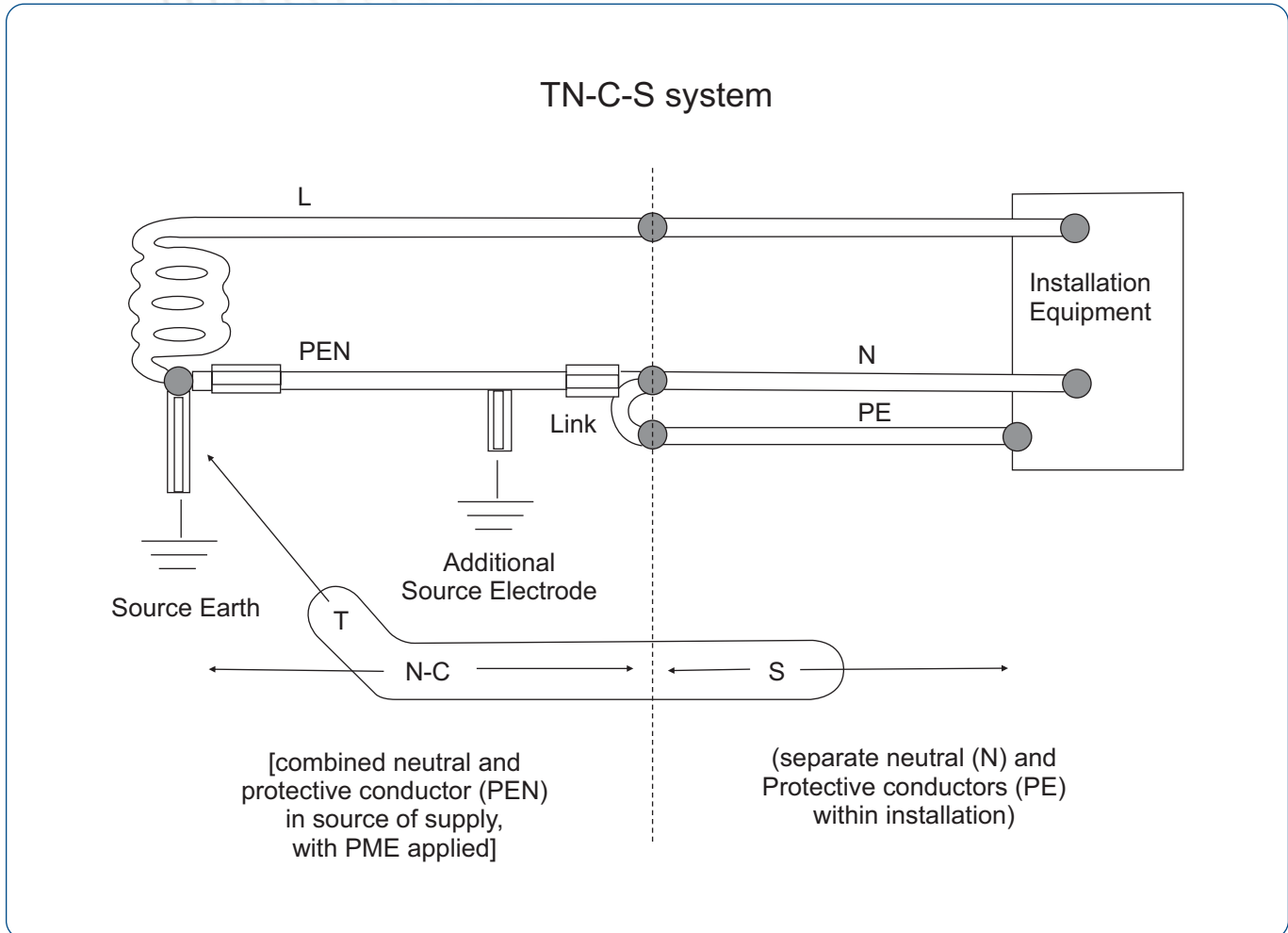

A TN-C-S system has the supply neutral conductor of a distribution main connected with earth at source and at intervals along its run. This is usually referred to as Protective Multiple Earthing (PME). With this arrangement the distributor's neutral conductor is also used to return earth

fault currents arising in the consumer's installation safely to the source. To achieve this, the distributor will provide a consumer's earthing terminal which is linked to the incoming neutral conductor.

4. TN-C system

If the N and PE neutral conductors are one and the same (PEN) in the system then such a system is called a TN-C system. In this system RCD will trip in case of leakage only

through human body. So this system is most the dangerous from the safety point of view.

TN-C System

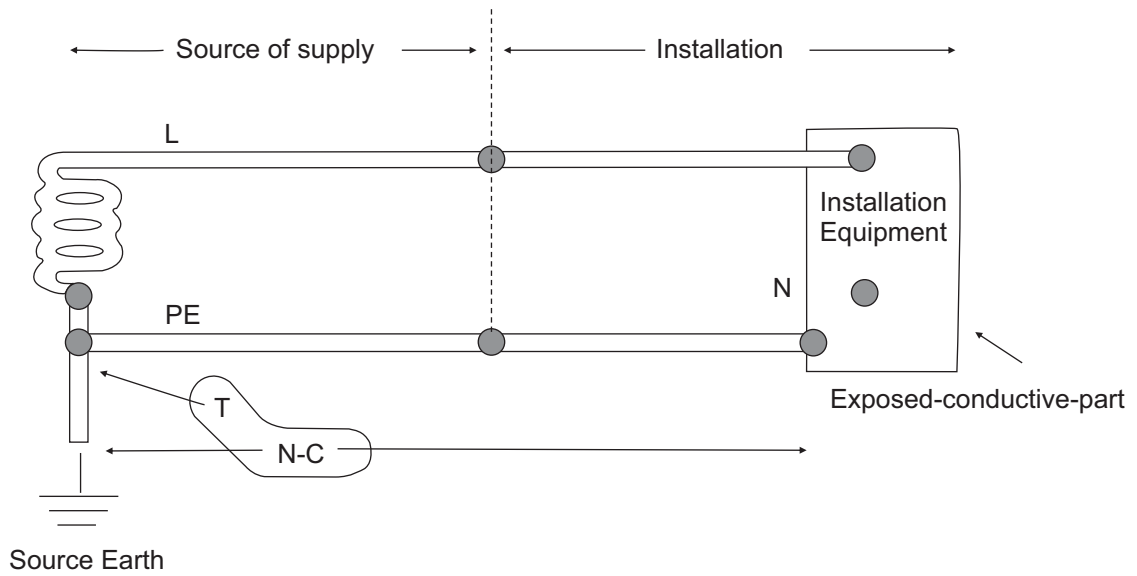

5. IT system

IT System

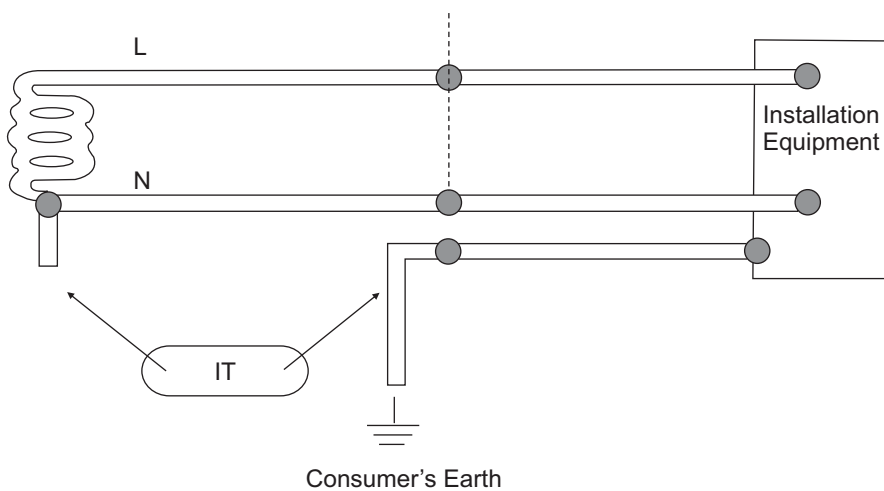

In an IT network, the distribution system has no connection to the earth at all, or it has only a high impedance connection. In such systems, an insulation monitoring

device is used to monitor the impedance. Only the IT system guarantees risk-free continuity of supply in the presence of an insulation fault.

Comparison of earthing systems

	TT	IT	TNS	TNC	TNC-S
Earth fault loop impedance	High	Highest	Low	Low	Low
RCD preferred?	Yes	No	Yes	No	After N and PE separate
Need earth electrode at site ?	Yes	Yes	No	No	No
PE conductor cost	Low	Low	Highest	Least	High
Risk of broken neutral	No	No	No	Highest	High
Safety	Safe	Less Safe	Safest	Least Safe	Safe
Electromagnetic interference	Least	Least	Low	High	Low
Safety risks	High loop impedance	Double fault, Overvoltage	Broken PE	Broken neutral	Broken Neutral
Advantages	Safe and reliable	Continuity of operation, cost	Safest	Cost	Safety and cost

Choice of earthing

Choice of earthing system for an installation depends on parameters:

1. Safety of person
2. Continuity of supply
3. Sensitivity of the equipment to the presence of harmonics in the system
4. Environment (risk of lightning strike)
5. Quality, maintenance and cost
6. Network size
7. Requirement of skilled operator and designer

Miniature Circuit Breaker (MCB)

An MCB is an automatically operated electrical switch designed to protect an electrical circuit from damage caused by overload and short circuit. Its basic function is to detect a fault condition and, by interrupting continuity, to immediately discontinue electrical flow. Unlike a fuse, which operates once and then has to be replaced, a circuit breaker can be reset (manually) to resume normal operation.

Selecting an MCB: In order to achieve perfect overload protection, the normal current of the MCB (I_m) should not be less than the design current of the circuit (I_c) and that (I_m)

should not exceed the current-carrying capacity of the conductors (I_w), and that the current causing effective operation of the protective device I_m does not exceed 1.45 times the current-carrying capacity of the conductor I_c , expressed as; $I_c < I_m < I_w$ e.g. If for a load of 800w, 220V; load current is 4A then wire capacity should be minimum 11A (i.e. 1 sq mm) and MCB rating should be 6A.

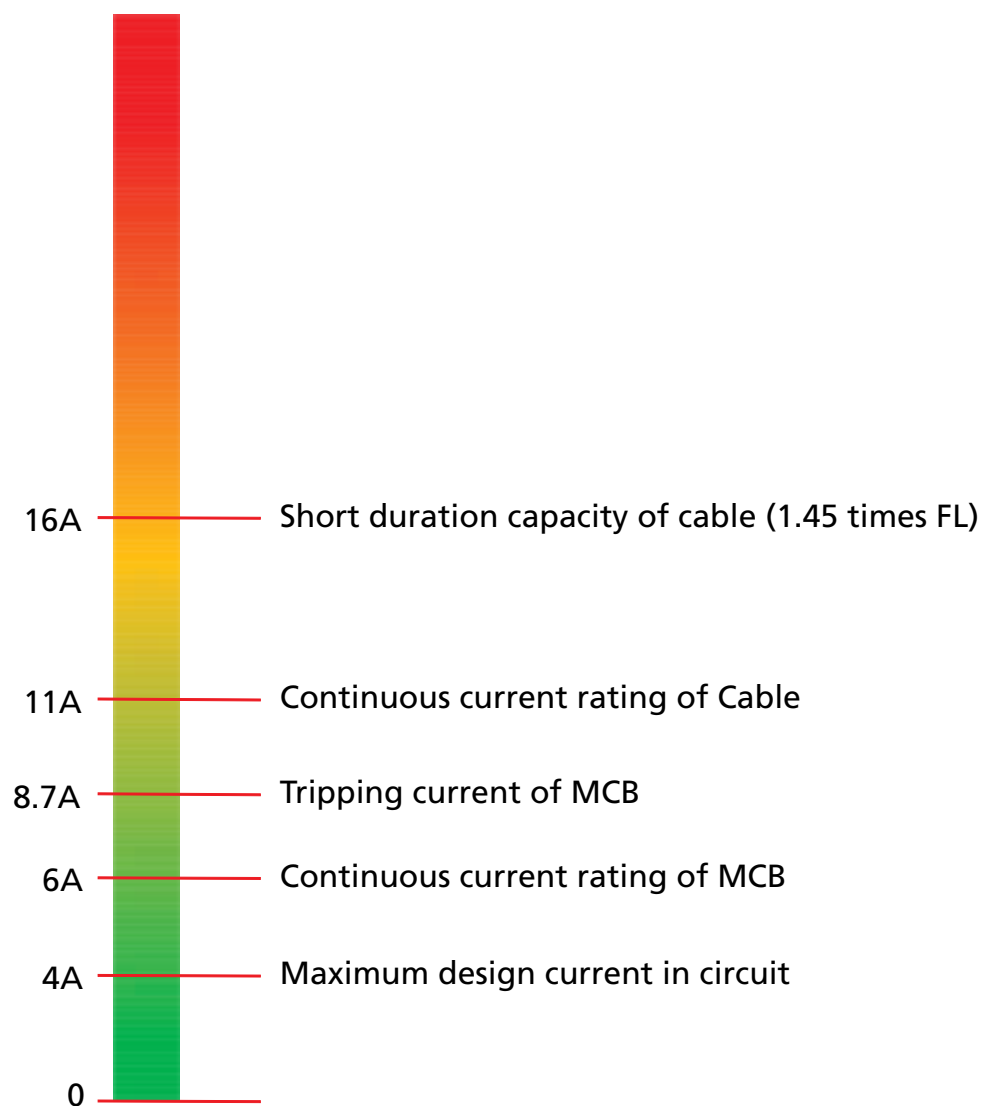

Application of Different Types of Curves

Type	Setting	Application
B	3-5 In	Generator-sensitive loads very long circuit runs <i>Example: Incandescent lights, Heater, Geyser</i>
C	5-10 In	General, light and power <i>Example: Flourescent lights, Small motors, Fans, Refrigerators Window / Split ACs</i>
D	10-20 In	Motors & transformers sodium lighting highly inductive loads <i>Example: Water lifting pumps, UPS, Medium size motors</i>

Temperature Derating

As per IS/IEC 60898, thermal calibration of an MCB is to be done at 30°C and if the manufacturer decides to do it at any other temperatures, the data has to be furnished on the breaker. When used at ambient temperatures exceeding the calibrated temperatures, MCBs tend to trip faster while carrying the rated current. This calls for de-rating the MCBs when used in ambiances, with temperatures higher than the design ambient temperature. At temperature higher than 30°C, the MCB require progressively less time to trip on the same level of overload.

Temperature Correction of EXORA MCBs :

In(A)	30°C	40°C	50°C
6	6	5.4	4.8
10	10	9	8
16	16	14.4	12.8
20	20	18	16
25	25	22.5	20
32	32	28.8	25.6
40	40	36	32
50	50	45	40
63	63	56.7	50.4

Current-limiting and Energy-limiting class

Current limitation is the technique used in circuit breakers to limit the short circuit current to reach its prospective value.

Current limitation can be achieved by following methods:

1. By Limiting the Fault

- By series resistors: using a series resistor to limit current on short circuit, but this wastes a lot of energy in limiting resistors.
- By series inductors coil – lot of heat loss combined with bulky size of inductor coils.

2. By Current Limiting Technology

- A current limiting circuit breaker cuts off the fault current much before it attains its peak value and hence greatly reduces the thermodynamic stresses on an electrical network.
- On a 50 Hz electrical network, fault current takes 5 msec to reach its prospective peak value.

A current limiting circuit breaker interrupts the fault current within 5 msec and clears the fault within 10 msec to limit the fault current and minimize let thru energy for maximum protection of electrical network.

Let thru energy is the amount of fault energy which passes through a circuit breaker to downstream network measured from the instant fault occurs in a system to the instant the circuit breaker clears the fault.

IEC classify MCBs into three classes depending upon their "Quality of current limiting" and let thru energy of a circuit breaker on short circuit class.

Class 1	No Limitation
Class 2	370 kA ² S
Class 3	110 kA ² S

As per EN-60898-1 -2003, for 10kA C-curve MCB (Greater than 16A up to and including 32A)

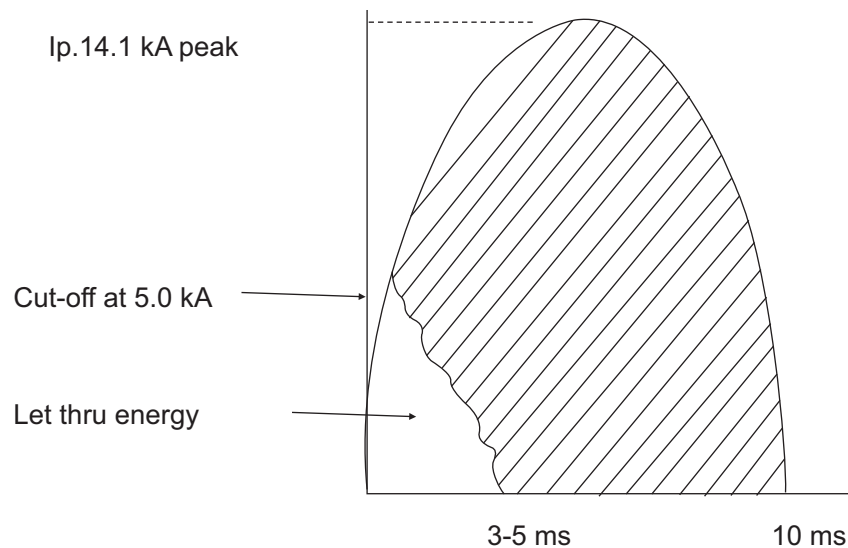

MCB

Some Important Definitions and Symbols (National and International Standards)

U_e = rated service voltage

U_i = rated insulation voltage ($>U_{emax}$)

U_{imp} = rated impulse withstand

I_{cm} = rated short circuit making capacity

I_{cn} = rated short circuit capacity

I_{cs} = rated service short circuit breaking capacity

$I_{\Delta n}$ = rated residual operating current (often called residual sensitivity)

I_n = rated current = maximum value of current used for the temperature rise test

Δt = trip delay of residual current devices

Fault Current	Trip time
1.13 I_n	Greater than 1 hour
1.45 I_n	Less than 1 hour
2.55 I_n	1 to 120 seconds

The inverse time delay characteristics of all MCBs complying with IEC 60898 must operate within these limits.

The difference between three types of characteristic curve B, C and D concerns only the magnetic instantaneous trip which provides short circuit protection.

Curve type	Breaker trip limits
Type B	3 to 5 times I_n
Type C	5 to 10 times I_n
Type D	10 to 20 times I_n

Graphs

I-T characteristics 10kA

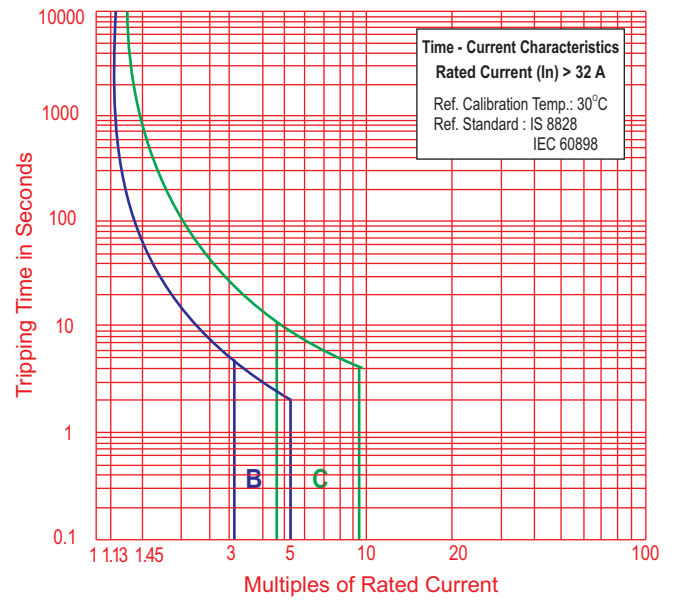
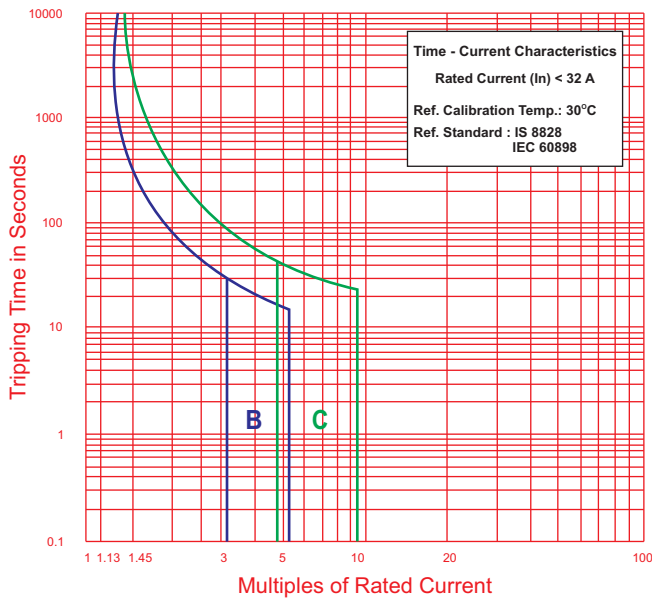

Watt Loss

Current (A) In	6	10	16	20	25	32	40	50	63
Loss (Watt)	1.36	1.8	1.8	2.49	3.52	3.4	3.75	5.17	5.93

RCCB

Danger of Human – Electrocutation

Current I v/s Flow Time

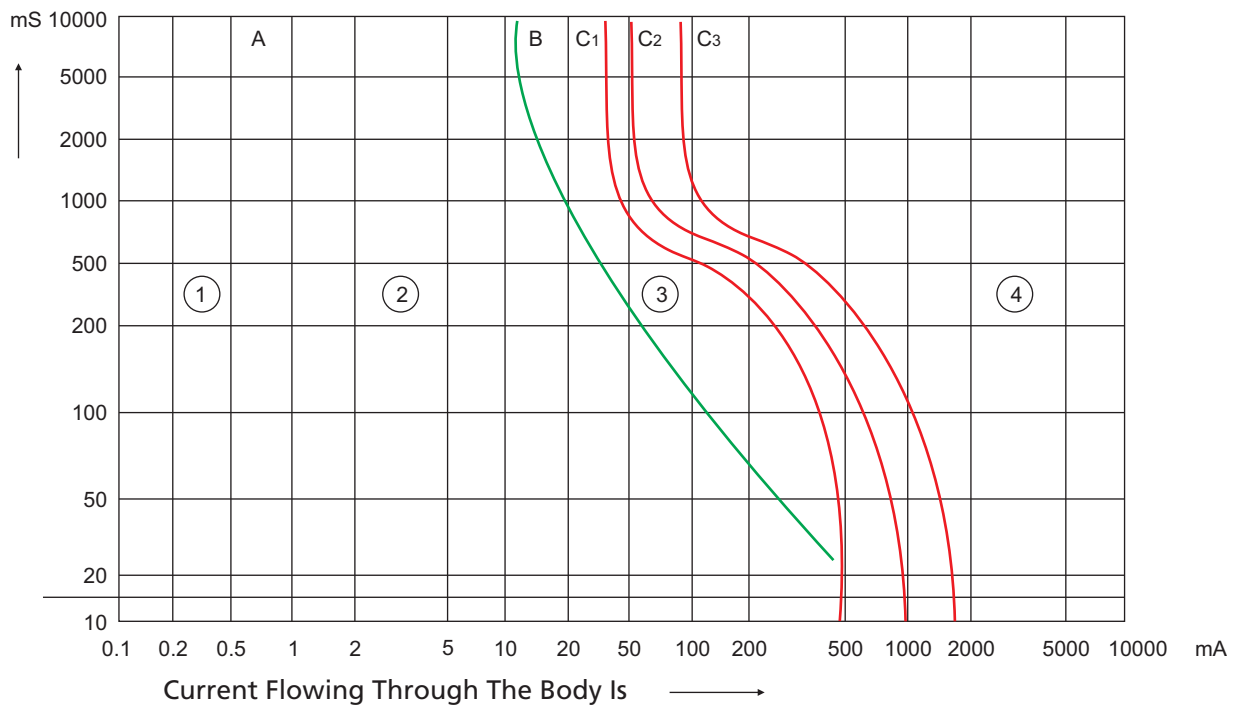

① Unperceived

③ Reversible effects : muscular contraction

② Perceived

④ Possible irreversible effects

C1= 5% risk C3>50% risk

Duration of current flow in the body as a function of current strength: In this graph, the effect of AC current (15 to 100 Hz) has been divide into four zones (as per IEC60479-1).

The gravity of an electric shock depends on the following factors:

- Current value
- Time it remains in the human body
- Path it takes through the human body
- Impedance of the human body
- When a current in excess of 30 mA flows through part of the human body, the person is in danger if this current is not interrupted in a relatively short time.

Importance of RCCB

The fault current overloads and short circuits can be detected by circuit breakers like MCBs, MCCBs, HRC Fuses, etc. But circuit breakers do not detect leakage currents which are dangerous for humans and livestock. If not detected, these leakages can lead to fire hazards. We need a solution that detects such leakage currents and disconnects the circuits from the power supply. Here comes the solution in the form of RCCB (Residual Current Circuit Breaker) also known as ELCB (Earth Leakage Circuit Breaker) which provides protection against direct and indirect contact of personnel or livestock and against fires.

Critical Current Thresholds

According to the medical study, effect of various current levels on human bodies is as shown below.

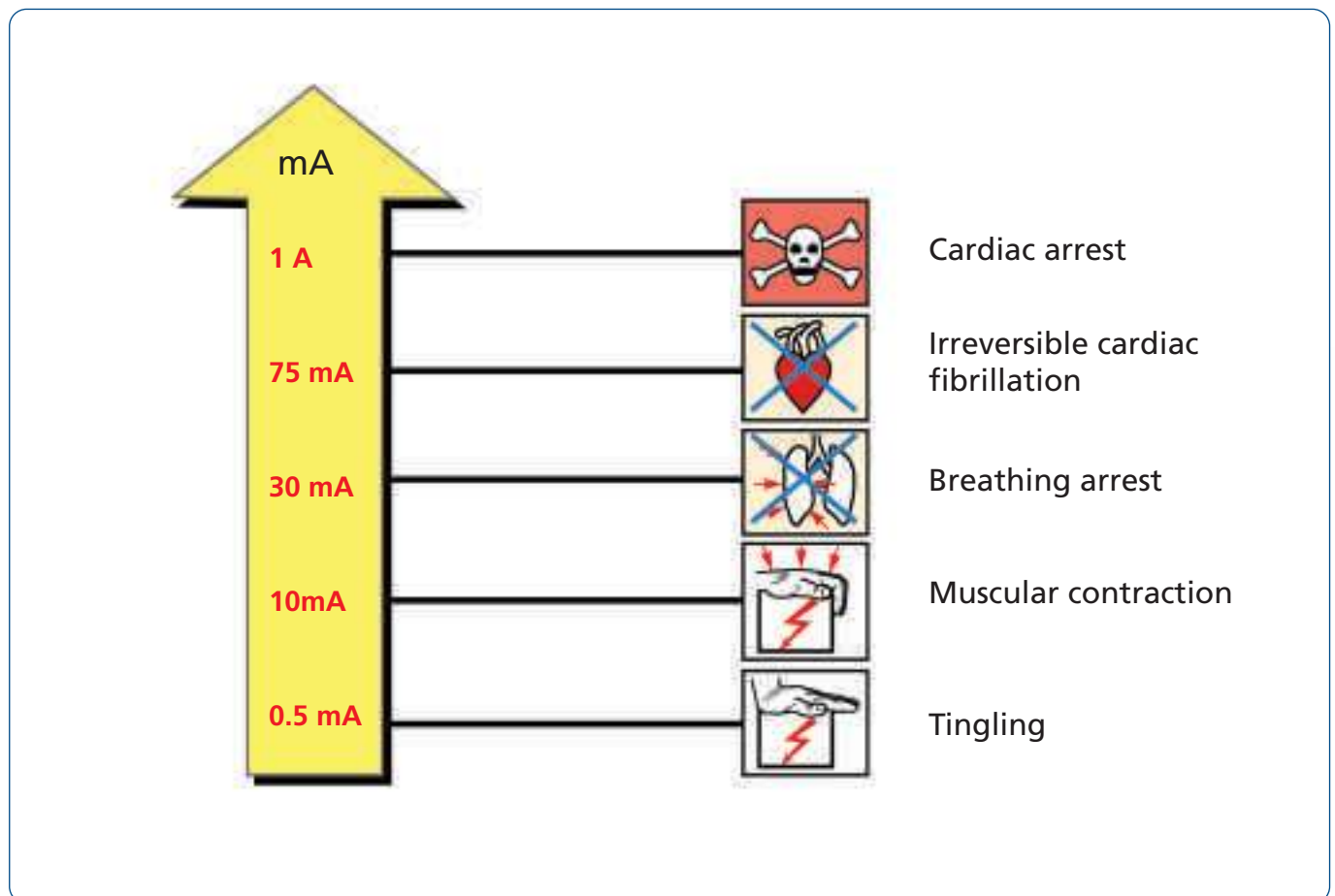

Working Principle of RCCB

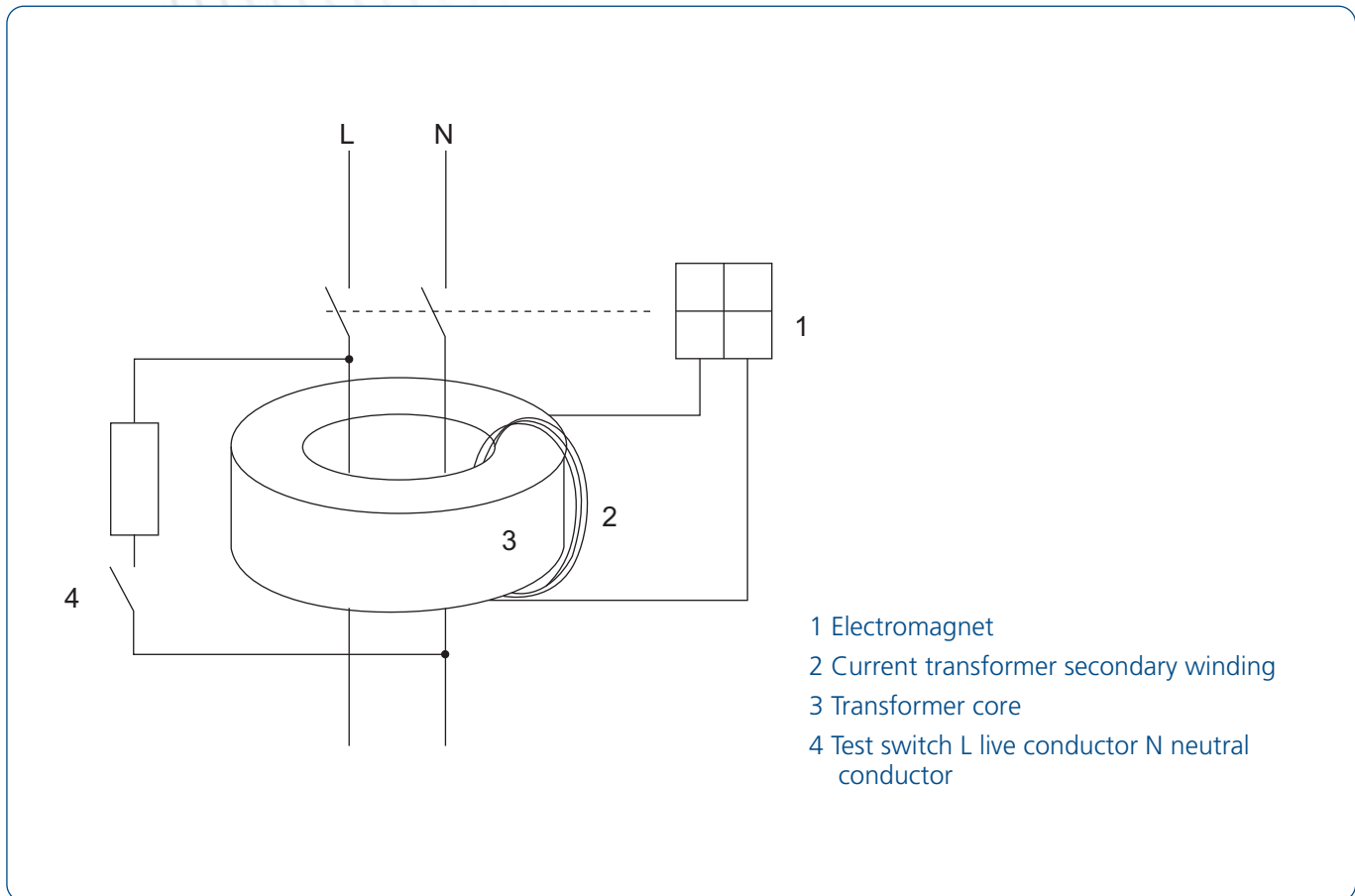

RCCBs operate by measuring the current balance between two conductors using a differential current transformer. This measures the difference between the current flowing out of the live conductor and that returning through the neutral conductor. If these do not sum to zero, there is a leakage of current to somewhere else (to earth/ground, or to another circuit), and the device will open its contacts.

RCCBs have different current sensitivities which can be used for various applications.

Sensitivities	Application
30mA	For protection against direct contacts
100mA	For protection against indirect contact (where generally leakage is high)
300mA	For protection against industrial installations, fire, etc.

To ensure safety, the RCCB switches turn off the protected circuit immediately. If there is an insulation fault causing a short-circuit to an exposed part (frame etc.) of machinery and equipment (protection against indirect contact), the maximum permissible touch voltage U must occur at a residual current greater than or equal to the rated residual operating current I that triggers the In RCCB. This condition is met by earthing the exposed part with a sufficiently low resistance to earth RE.

$$\text{Earth Resistance (RE)} < \frac{\text{Touch Voltage (U)}}{\text{Rated Residual Operating Current (I)}}$$

Precaution for Installations

- Wiring should be done as per the wiring diagram. by a trained and qualified electrician.
- All wiring necessary for operation shall be passed through the RCCB.
- The neutral conductor must be insulated against earth to the same extent as the live conductors.
- All equipment used must be properly earthed.
- To ensure correct functioning, care must be taken that the neutral conductor on the load side of the RCCB must not be connected to earth, otherwise nuisance tripping may occur or tripping may be impaired.
- Suitable device either MCB or HRC fuses shall be used for short circuit and overload protection of the circuit under installation.

Fault finding when RCCB trips

Switch OFF all the switches/MCB connected in the circuit downstream the RCCB. Switch ON RCCB and switch ON the Switches one by one. You will find that during switching ON of a particular appliance/switch RCCB trips again and again which shows that this is the faulty circuit/appliance. Isolate the faulty circuit, rectify the fault and switch ON the RCCB.

Faults existing downstream of the RCD

- **Indirect contact.** An RCD may be used to provide protection against electric shock due to indirect contact in an installation.
- **Direct contact.** An RCD may be used to provide supplementary protection against direct contact.

- **Incorrect application.** An RCD must be correctly selected and erected for the particular application. For example, protecting an entire installation using a single high sensitivity RCD can, in many cases, lead to unwanted tripping, particularly in industrial environments where inductive loads will cause greater transient overvoltages and where longer cable runs will result in larger values of capacitance to earth.

- **No discrimination between series connected RCDs.** A fault downstream of two series-connected RCDs may result in operation of either device. A fault downstream of the second device will be 'seen' by both devices. Inconvenience may result if the upstream device operates. Discrimination, where required, must be ensured by means such as selecting a time delayed device for the upstream device.

- **Loose connections.** A loose connection downstream of an RCD may cause it to operate due to transient voltages or capacitive effects. Every connection must be properly constructed of durable electrical continuity and adequate mechanical strength correctly selected enclosed and accessible, where required.

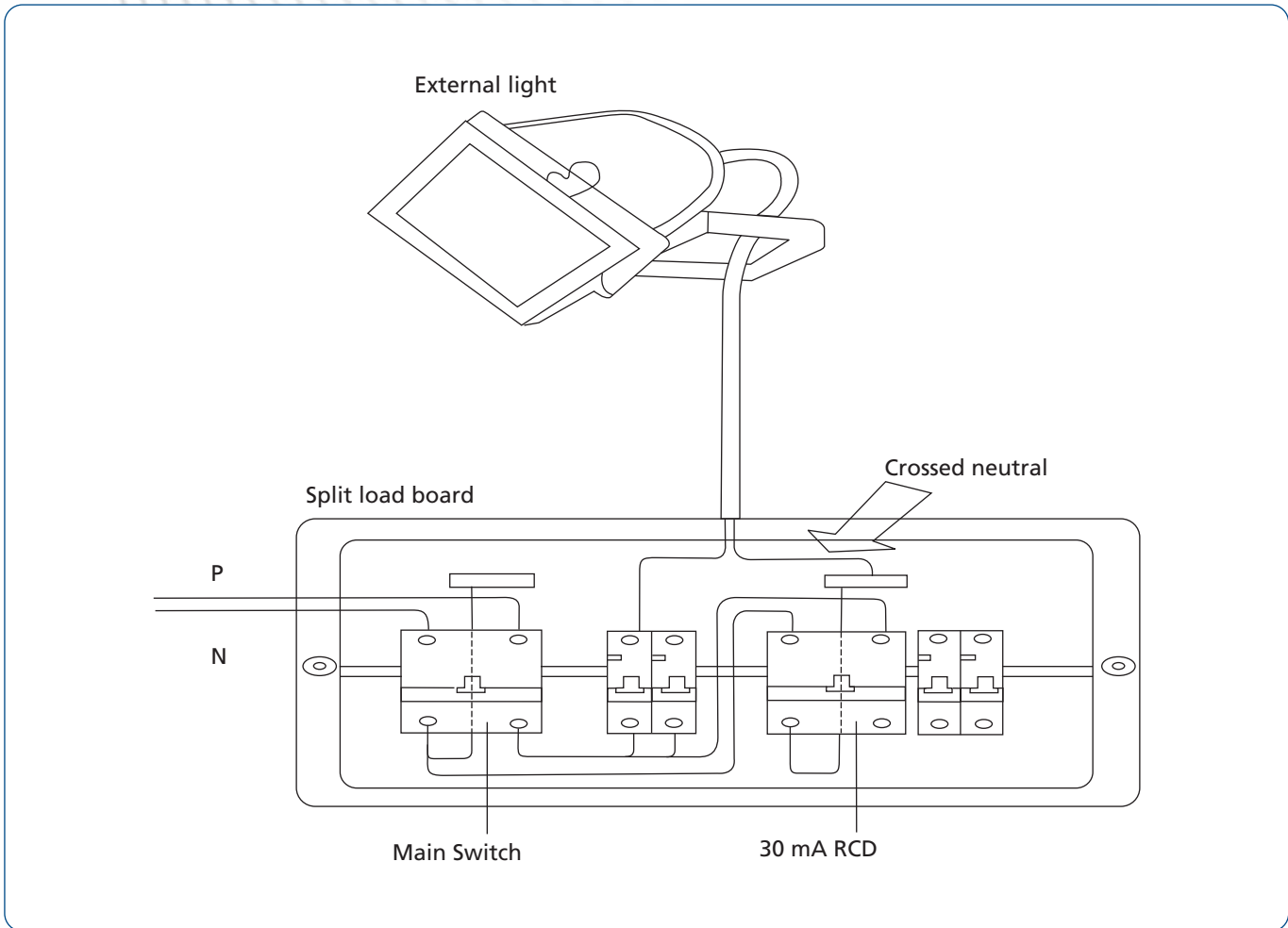

- Crossed neutral on split load distribution board or consumer unit.

In the above diagram, the external lighting circuit has been incorrectly connected. The MCB supplying the circuit is connected to the non-RCD-protected side of the split load board but the neutral conductor for the circuit has been inadvertently connected downstream of the RCD.

As soon as the outside light is energized, the RCD will see a large imbalance and will operate. The neutral must be taken from the same final circuit, never from another circuit, as has happened in this example. Circuits must be kept separate; in this example a 'borrowed neutral' situation exists presenting a potential shock risk for an electrician attempting to troubleshoot the problem.

- **Neutral-to-Earth fault.** A neutral-to earth fault or in advertent connection of neutral to earth downstream of an RCD will probably result in the device operating as part of the neutral current will flow in the circuit protective conductor resulting in the RCD seeing an imbalance (refer fig below). A neutral-to-earth fault can be caused by:
 - A neutral conductor touching an earthed mounting box or earthed metal conduit
 - Reversed neutral and earth connections at an accessory or item of current-using equipment
 - Withdrawal of a fuse or switching off a circuit-breaker in a final circuit resulting in an RCD tripping as the neutral is normally not interrupted.
 - Nails and picture hooks, screws and power drills: A floorboard nail driven between the neutral and earth conductors creates a neutral to earth fault which is likely to cause an upstream RCD to trip. The fault can be located by insulation testing. The damaged cable must be replaced and either relocated to avoid further damage or protected.
 - Mineral insulated cables. Mineral insulated cables can absorb moisture if not correctly terminated resulting in reduced insulation which may cause an RCD to trip as a certain amount of outgoing phase current will return through the MI cable sheath causing the RCD to detect an imbalance. Insulation testing should identify the problem.
- Moisture ingress can cause reduced insulation resulting in RCD operation. Reduced insulation can result from wet plaster, condensation or water entry into accessories. Similarly, some appliances may exhibit reduced insulation causing RCD operation. Certain installed services, such as heating elements in cookers can have reduced insulation when cold; the insulation increasing when hot. The manufacturer's instructions should be consulted.
- Double-pole switching. Double pole switching within the fixed wiring is known to trip an RCD when switching off or on due to capacitive effects. Changing over from double pole to single pole switching can overcome the problem, where such replacement is permissible and safe.

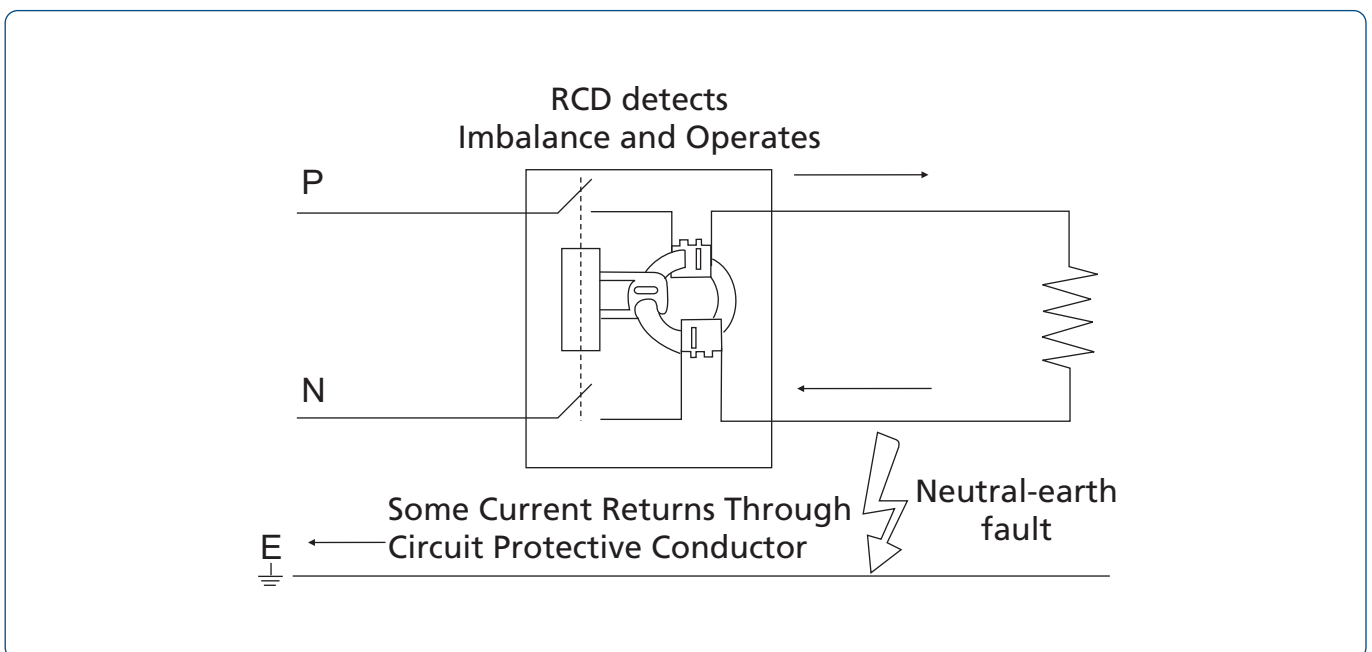

Faults Upstream of the RCD

A loose connection upstream of the RCD such as at the main switch or at the busbar connections can cause the device to operate.

Mains-borne disturbances such as spikes, voltage surges and dips, a lightning strike and the operation of distribution network switchgear and protective devices combined with capacitance to earth within the installation can cause unwanted RCD operation. A filter may be of assistance.

Site machinery or plant and installed services can cause mains borne interference. Motors such as lift motors, control gear for discharge lighting and transformer inrush currents can cause unwanted RCD operation. Although significant transients can arise within an installation they would normally only occur under fault conditions. They might, however, travel to other installations where they could cause unwanted tripping of a RCD.

Overhead lines: Unwanted tripping may occur more frequently in an installation supplied by overhead lines compared to one supplied by an underground concentric cable. An underground concentric cable is, by its very nature, a good attenuator of transient overvoltages. Spurious tripping may be avoided by installing a filter upstream of the RCD at the origin of the installation.

Domestic Installation (RCCBs)

RCCBs can be installed mainly in two ways:

1. Whole house protection: In this type of protection the RCCBs serve as the main switch. This type of protection is very popular but has a major disadvantage that all the circuits are disconnected in the event of a fault.

2. Selective protection: This type of protection can be divided into two types.

A. Split busbar consumer unit: In this case all circuits are fed through an overall isolator and selected circuits additionally through RCCBs. The examples of selected circuits are socket outlets, garage circuits, etc. So this reduces the inconvenience in the event of a fault.

B. Per Phase Isolation (PPI): A RCCB is used as sub-incomer for each individual phase. In case of a fault, only faulty phase will be disconnected and remaining phases will not be affected.

SPDs

a. IEC Standards

As per international standards, SPDs are classified as lightning current arresters (Class I), surge protection devices (Class II) or device protection (Class III). Each Class is defined by performance testing methods for surge current handling capability.

Type 1 / Class I SPDs (Lightning Arresters) are mainly installed in the electrical entry panel or the Main Distribution Panel. This is the first-stage protection in the electrical network, and the surge arrester is designed to divert lightning energy caused by over-voltage comparable to that of a direct lightning strike to the power lines or equipment. These protectors must be designed to survive the 10/350 μ s wave form. In addition, Class I lightning arresters are tested with 8/20 μ s current impulses for nominal discharge current ratings..

It must be understood that Class I SPDs are only for insulation breakdown protection, e.g.: protecting the wires, insulation/dielectrics, and other components of the electrical distribution system. These SPDs are not intended to prevent damage to electronics and sensitive equipment. Most SPD manufacturers use discharge-gap technology to meet the challenging test requirements of surviving multiple 10/350 μ s wave shape hits without damage or degradation. The discharge gap handles high surge currents of 100kA and does not suffer from leakage current when not conducting. One drawback is that the relatively slow response time (~100 μ s typically) results in a voltage level protection (VPL) of 1.5 - 2 kV. The minimum discharge capability (Iimp) of a Class I SPD is 25kA.

Type 2 / Class II SPDs are mainly installed in secondary distribution panels as the second stage protection. The Class II SPD working with the first stage Class I arrester provides a better level of protection for equipment. These SPDs offer a lower surge capacity and provide a lower clamp level than the primary suppressor. These SPDs also suppress any surge currents generated by induced lightning currents /partial lightning and operational switching action in the

electrical network. These SPDs are tested with a 8/20 μ s medium-energy or low-energy surge currents, and typically offer a VPL of around 1.5 kV. It is important to note that this voltage level can still potentially allow damage to sensitive equipment. It is also interesting to note that some SPDs offer combined Type 1 and 2 protection of loads against both direct and indirect lightning strokes.

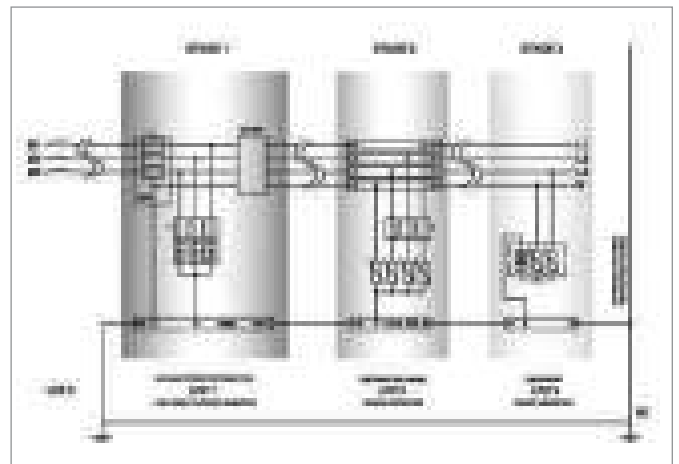

Type 3 / Class III SPDs must be installed as a supplement to Type 2 SPD and be located in the immediate vicinity of sensitive loads. Some critical applications with sensitive equipment include: Medical Imaging, Cloud Servers, and Video Surveillance. The function of a Class 3 device is protection of sensitive electronic equipment and thus the voltage protection level should be < 600 V. These devices are tested similar to the Class II SPDs (1.2/50 μ s and 8/20 μ s waveforms) but have lower discharge current capability. Often, Type 2 products are declared as Type 3. It is important to check that these SPDs offer voltage levels of \leq 600 V.

Installation and Wiring

- 1 Install only in a restricted access power distribution cabinet that requires a key or tool to open.
- 2 The SPD should only be installed by a licensed electrician.
- 3 All local and national electric codes must be observed.
- 4 Keep wires as short as possible (maximum length \leq 0.5 m) and free of sharp bends.
- 5 Before installation, shut off power to prevent accidental electrical shock or injury.
- 6 The ground conductor should be insulated stranded copper greater than 10 mm² (#6 AWG) diameter. The power conductors should be copper stranded insulated greater than 6 mm² (#10 AWG) diameter.

Usage and Maintenance

- 1 The SPD should be scheduled for periodic inspection to ensure SPD is operational, each module is securely inserted in base and all wire connections are tight.

SPD selection

Coordination Stage	Stage 1	Stage 2	Stage 3
Surge Threat	Lightning	Lightning & Inductive	Inductive
IEC 61643-1	Class I test	Class II test (8/20 μ s)	Class III test
EN/IEC 61643-11	Type 1 : (10/350 μ s)	Type 2 : (8/20 μ s)	Type 3 : (8/20 μ s)
IEC Test Waveform	10/350 μ s	8/20 μ s	1.2/50 μ s + 8/20 μ s
IEEE C62.41	Location C (8/20 μ s)	Location B (8/20 μ s)	Location A (8/20 μ s)
UL 1449	Type 1 (8/20 μ s)	Type 2 (8/20 μ s)	Type 3 (8/20 μ s)
IEEE Test Waveform	8/20 μ s	8/20 μ s	1.2/50 μ s + 8/20 μ s

ACCL

ACCL Overload tripping function

During generator supply, when the load exceeds set trip current, the ACCL will disconnect the load for 15 seconds. Then it will again reconnect the load for 30 seconds and check for overload condition.

If overload persists, ACCL will disconnect the load and this cycle is repeated thrice. If overload condition still persists, ACCL will disconnect the load permanently.

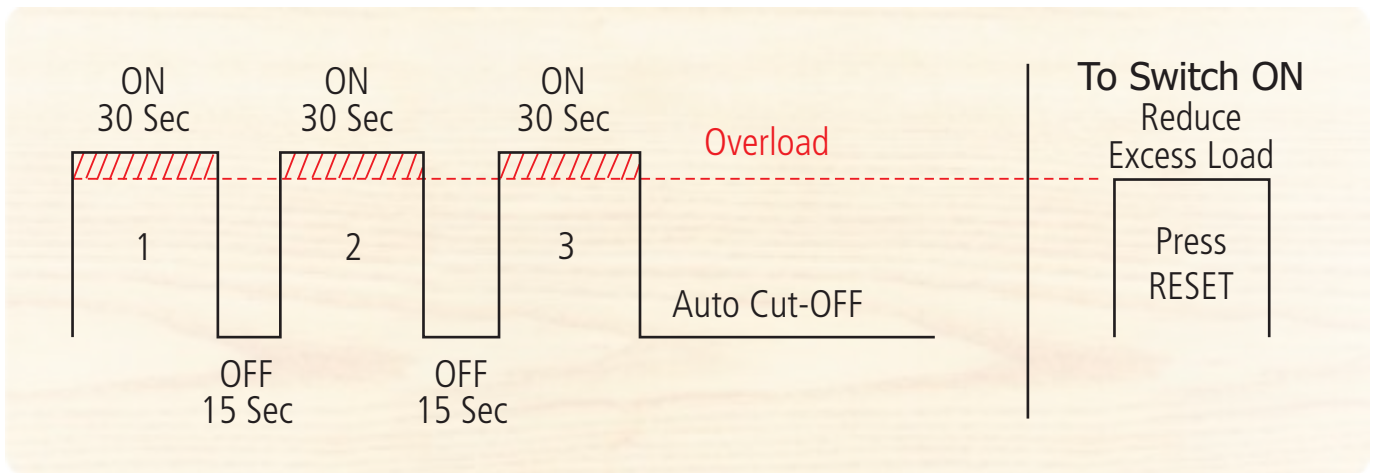

To restore the supply to load, switch off all non-essential loads to bring down the load current below trip set current, and press the RESET button.

Electrical Standard Products (ESP) Branch Offices:

REGISTERED OFFICE AND HEAD OFFICE

L&T House, Ballard Estate
P. O. Box 278
Mumbai 400 001
Tel: 022-67525656
Fax: 022-67525858
Website: www.Larsentoubro.com

ELECTRICAL STANDARD PRODUCTS (ESP)

501, Sakar Complex I
Opp. Gandhigram Rly. Station
Ashram Road
Ahmedabad 380 009
Tel: 079-66304006-11
Fax: 079-66304025
e-mail: esp-ahm@LNTEBG.com

38, Cubbon Road, P. O. Box 5098
Bangalore 560 001
Tel: 080-25020100 / 25020324
Fax: 080-25580525
e-mail: esp-blr@LNTEBG.com

131/1, Zone II
Maharana Pratap Nagar
Bhopal 462 011
Tel: 0755-3080511 / 05 / 08 / 13 / 17 / 19
Fax: 0755-3080502
e-mail: esp-bho@LNTEBG.com

Plot No. 559, Annapurna Complex
Lewis Road
Bhubaneswar 751 014
Tel: 0674-6451342, 2436690, 2436696
Fax: 0674-2537309
e-mail: nayakd@LNTEBG.com

Aspire Towers, 4th Floor
Plot No. 55, Phase-I
Industrial & Business Park
Chandigarh-160 002
Tel: 0172-4646840 / 41 / 42 / 46 / 53
Fax: 0172-4646802
Email: esp-chd@Lntebg.com

L&T Construction Campus
TC-1 Building, II Floor
Mount-Poonamallee Road
Manapakkam
Chennai 600 089
Tel: 044-2270 6800
Fax: 044-22706940
e-mail: esp-maa1@LNTEBG.com

67, Appuswamy Road
Post Bag 7156
Opp. Nirmala College
Coimbatore 641 045
Tel: 0422-2588120 / 1 / 5
Fax: 0422-2588148
e-mail: esp-cbe@LNTEBG.com

Khairasol, Degaul Avenue
Durgapur 713 212
Tel: 2559848, 2559849, 2559844
Fax: 0343-2553614
e-mail: esp-dgp@LNTEBG.com

5, Milanpur Road, Bamuni Maidan
Guwahati 781 021
Tel: +91 8876554410 / 8876554417
Fax: 361-2551308
e-mail: hazrasudipto@LNTEBG.com

II Floor, Vasantha Chambers
5-10-173, Fateh Maidan Road
Hyderabad 500 004
Tel: 040-67015052
Fax: 040-23296468
e-mail: esp-hyd@LNTEBG.com

Monarch Building, 1st Floor
D-236 & 237, Amrapali Marg
Vaishali Nagar
Jaipur 302 021
Tel: 0141-4385914 to 18
Fax: 0141-4385925
e-mail: esp-jai@LNTEBG.com

Akashdeep Plaza, 2nd Floor
P. O. Golmuri
Jamshedpur 831 003
Jharkhand
Tel: 0657-2312205 / 38
Fax: 0657-2341250
e-mail: esp-jam@LNTEBG.com

Skybright Bldg; M. G. Road
Ravipuram Junction, Ernakulam
Kochi 682 016
Tel: 0484-4409420 / 4 / 5 / 7
Fax: 0484-4409426
e-mail: esp-cok@LNTEBG.com

3-B, Shakespeare Sarani
Kolkata 700 071
Tel: 033-44002572 / 3 / 4
Fax: 033-22821025 / 7587
e-mail: esp-ccu@LNTEBG.com

A28, Indira Nagar, Faizabad Road
Lucknow 226 016
Tel: 0522-4929905 / 04
Fax: 0522-2311671
e-mail: esp-lko@LNTEBG.com

No: 73, Karpaga Nagar, 8th Street
K. Pudur
Madurai 625 007
Tel: 0452-2537404, 2521068
Fax: 0452-2537552
e-mail: esp-mdu@LNTEBG.com

L&T Business Park,
Tower 'B' / 5th Floor
Saki Vihar Road, Powai
Mumbai 400 072
Tel: 022-67052874 / 2737 / 1156
Fax: 022-67051112
e-mail: esp-bom@LNTEBG.com

12, Shivaji Nagar
North Ambajhari Road
Nagpur 440 010
Tel: 0712-2260012 / 6606421
Fax: 2260030 / 6606434
e-mail: esp-nag@LNTEBG.com

32, Shivaji Marg
P. O. Box 6223
New Delhi 110 015
Tel: 011-41419514 / 5 / 6
Fax: 011-41419600
e-mail: esp-del@LNTEBG.com

L&T House
P. O. Box 119
191/1, Dhole Patil Road
Pune 411 001
Tel: 020-66033395 / 66033279
Fax: 020-26164048 / 26164910
e-mail: esp-pnq@LNTEBG.com

Crystal Tower,
4th Floor, G. E. Road
Telibandha
Raipur - 492 006
Tel: 0771-4283214
e-mail: esp-raipur@LNTEBG.com

3rd Floor
Vishwakarma Chambers
Majura Gate, Ring Road
Surat 395 002
Tel: 0261-2473726
Fax: 0261-2477078
e-mail: esp-sur@LNTEBG.com

Radhadaya Complex
Old Padra Road
Near Charotar Society
Vadodara 390 007
Tel: 0265-6613610 / 1 / 2
Fax: 0265-2336184
e-mail: esp-bar@LNTEBG.com

Door No. 49-38-14/3/2, 1st floor,
NGGO's Colony, Akkayyapalem,
Visakhapatnam - 530 016
Tel: 0891 2791126, 2711125
Fax.: 0891 2791100
Email: esp-viz@LNTEBG.com

Product improvement is a continuous process. For the latest information and special applications, please contact any of our offices listed here.
Product photographs shown, are for representative purpose only.



Larsen & Toubro Limited, Electrical Standard Products
Powai Campus, Mumbai 400 072

Customer Interaction Center (CIC)

BSNL / MTNL (toll free): 1800 233 5858 Reliance (toll free): 1800 200 5858
Tel: 022 6774 5858 Fax: 022 6774 5859 Email: cic@Lntebg.com
Web: www.Lntebg.com