

d sine -DZ1 | Moulded Case Circuit Breakers

User Centric Innovation





A technology idea often forms the foundation of innovation in a product and the success of its outcome is determined by the users' experience. Talking to customers and taking their feedback gives an assurance that the innovation would meet the expected and even aspired results. The dsine DZ range is an outcome of users' feedback that has been recorded, analysed and incorporated in its design and development journey.

About L&T Electrical & Automation

L&T Electrical & Automation (E&A) is a market leader for electrical distribution, monitoring and control solutions in the low voltage category.

Popular among customers as L&T Switchgear, E&A offers a wide range of low and medium voltage switchgear, motor starters, electrical systems, industrial automation, building electrical solutions, energy management solutions, electrical modernization solutions and metering solutions. Its products and solutions cater to key sectors of economy like industries, utilities, infrastructure, building and agriculture.

E&A's manufacturing operations at Navi Mumbai, Ahmednagar, Vadodara, Coimbatore and Mysuru in India adhere to global practices of excellence and receive support from well-equipped in-house design and development centres as well as tooling facilities that contribute to precision in manufacturing.

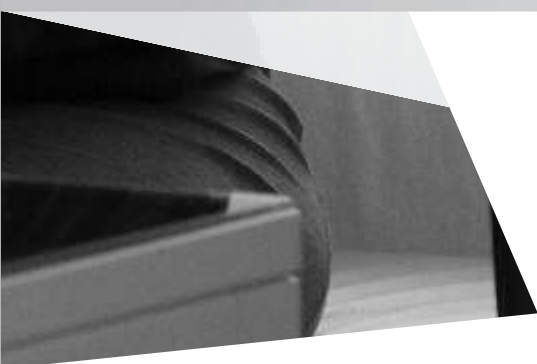

**L&T Electrical & Automation
is constantly engaged in
adding value to the business
of customers like you.**

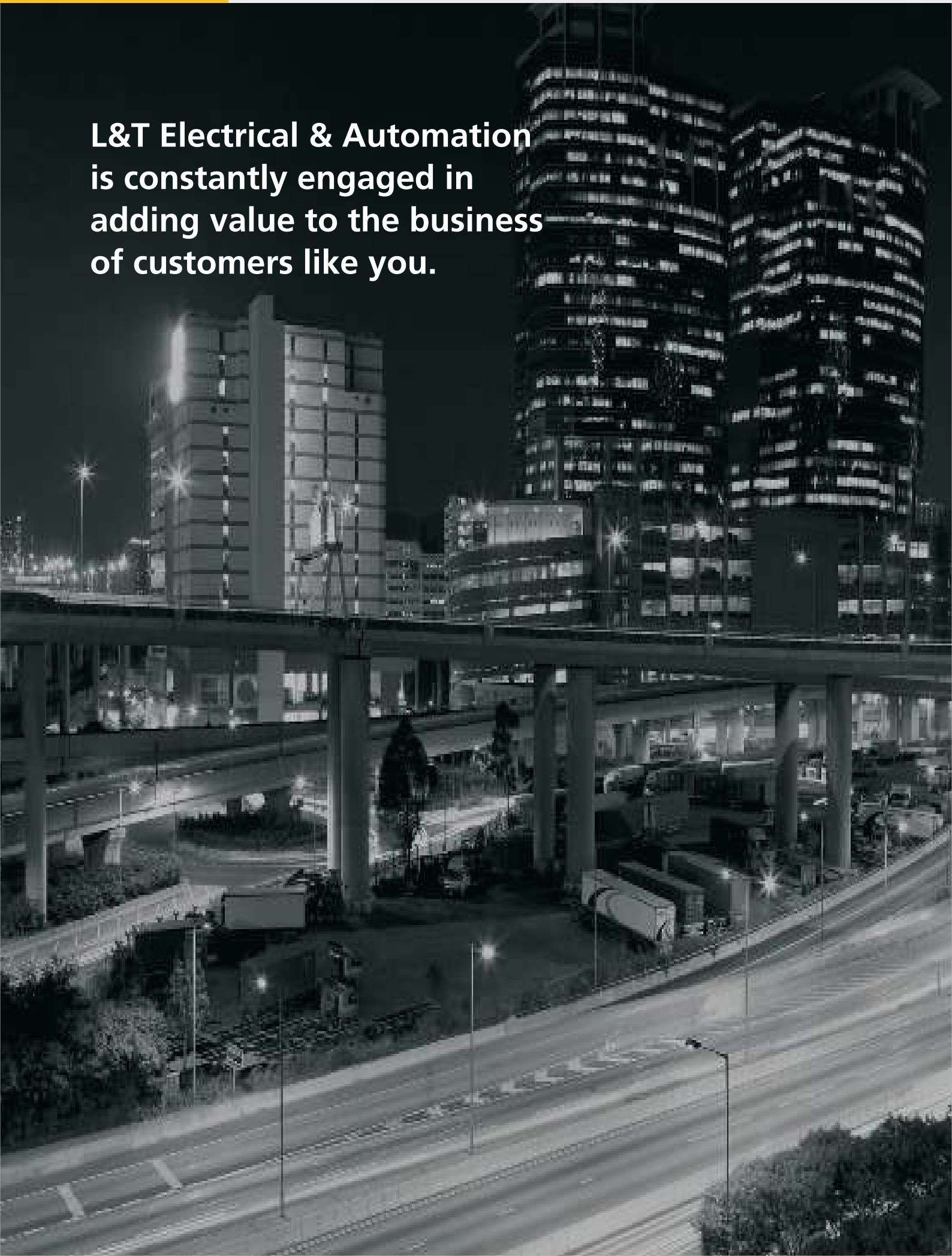

Range Features	06
Protection Releases	06
Thermal Magnetic Release	06
Microprocessor Release	07
Termination	10
Technical Datasheet	11
Altitude Correction Factors	12
Characteristic Curves	13
Current-Limiting Curve	17
Energy-Limiting Curve	17
Overall Dimensions	18
Mounting Dimensions	19
Accessories Dimensions	20
Type 2 Co-ordination Chart	22

Range features:

- Rated Current : 16 A to 160 A
- Available in 3 Pole & 4 Pole
- Protection using both thermal magnetic & microprocessor based release
- Various types of terminations
- Switch disconnecter and motor backup versions
- No load line bias
- Ambient temperature compensation upto 55°C *
- Ics=100% of Icu
- Suitable for isolation
- Wide range of internal and external accessories
- Conforms to IS 60947-2, IEC 60947-2 and EN 60947-2

DZ1		
Protection Release	Ratings (A)	Breaking Capacity (kA) Ics= 100% of Icu
Microprocessor	25, 40, 63, 100, 160	36, 50
Thermal Magnetic	16, 20, 25, 32, 40, 50, 63, 80, 100, 125, 160	
Only Magnetic	16, 20, 25, 32, 40, 50, 63, 80, 100, 125, 160	

* No Deration upto 55 °C

Protection Release features

- Wide range of protections using thermal magnetic and microprocessor based trip unit
- Long time (overload) setting starts from 0.25In for iTRP-1 release and 0.67In for thermal magnetic release
- Transparent release cover

Thermal Magnetic Release:

- Adjustable overload setting
- Adjustable short circuit setting*
- True RMS sensing

iTM - AA	
LI	
Rated Current (A)	16, 20, 25, 32, 40, 50, 63, 80, 100, 125, 160
Frame	DZ1
OverLoad (Phase)	
Current Setting Ir (Ir = x In)	0.67 to 1 x In
Instantaneous	
Current Setting Ii (Ii = x In)	6 to 12 x In*

* 16 A to 50 A : Fixed Magnetic 375 A



Microprocessor Releases: *i*TRP-1

- Wide range of overload setting starting from $0.25I_n$
- Adjustable Trip class
- Neutral overload protection
- Short circuit setting with delay or Instantaneous option
- Adjustable Instantaneous Setting
- Thermal Memory with option of Defeat
- Provision for release testing



<i>i</i>TRP-1	
LS/I	
Rated Current (A)	25, 40, 63, 100, 160
Frame	DZ1
OverLoad (Phase)	
Current Setting I_r ($I_r = x I_n$)	0.25 to $1 \times I_n$ (in step of 0.05)
Time delay, t_r (Inverse)	10s at $6I_r$, 3s at $6I_r$, 10s at $7.2 I_r$, 3s at $7.2I_r$
Protection Mode	ON/OFF
Thermal Memory	ON/OFF
OverLoad (Neutral)	
Current Setting I_n ($I_n = x I_r$)	OFF / $1.0 \times I_r$
Time delay, t_r (Inverse)	As per Overload Curve Setting
Protection Mode	ON/OFF
Short Circuit	
Current Setting I_s ($I_s = x I_r$)	1.5 to $12 \times I_r$ (in step of 0.5)
Time delay, t_s	As per I^2t curve /150 msec
I^2t	ON/OFF
or Instantaneous	
Current Setting I_i ($I_i = x I_n$)	1.5 to $12 \times I_n$ (in step of 0.5)

Microprocessor Releases: *i*TRP-2

- Wide range of overload settings from 0.25In
- Adjustable neutral overload protection
- Short circuit setting with delay
- Adjustable instantaneous setting
- Thermal memory defeat
- Provision for release testing
- Individual fault indication LEDs

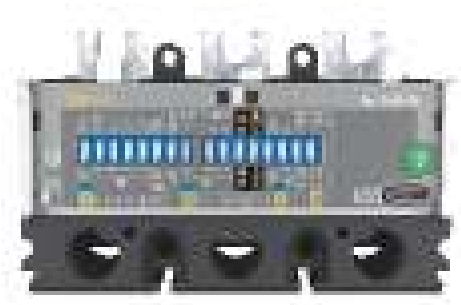

<i>i</i> TRP-2	
LSIN	
Rated Current (A)	25, 40, 63, 100, 160
Frame	DZ1
OverLoad (Phase)	
Current Setting I_r ($I_r = x I_n$)	0.25 to 1 x I_n (in step of 0.05)
Time delay, t_r (Inverse)	10s at 6 I_r
Protection Mode	ON/OFF
Thermal Memory	Enable/Disable
OverLoad (Neutral)	
Current Setting I_n ($I_n = x I_r$)	OFF / 0.5/ 1.0/ 2.0 x I_r
Time delay, t_r (Inverse)	As per Overload Curve Setting
Protection Mode	On/OFF
Short Circuit	
Current Setting I_{sd} ($I_{sd} = x I_r$)	1.5, 3, 4.5, 5.5, 6, 7, 8.5, 10 x I_r
Time delay, t_s	100ms/200ms
I ² T	ON/OFF
Protection Mode	ON/OFF
Instantaneous	
Current Setting I_i ($I_i = x I_n$)	6 & 12 I_n
Protection Mode	ON/OFF

Microprocessor Releases: *i*TRP-3

- Wide range of overload settings from $0.25I_n$
- Adjustable neutral overload protection
- Short circuit setting with delay
- Adjustable instantaneous setting
- Thermal memory defeat
- Provision for release testing
- Individual fault indication LEDs
- Inbuilt earth fault protection



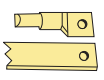

<i>i</i> TRP-3	
LSING	
Rated Current (A)	25, 40, 63, 100, 160
Frame	DZ1
OverLoad (Phase)	
Current Setting I_r ($I_r = x I_n$)	0.25 to $1 \times I_n$ (in step of 0.05)
Time delay, t_r (Inverse)	10s at $6I_r$
Protection Mode	ON/OFF
Thermal Memory	Enable/ Disable
OverLoad (Neutral)	
Current Setting I_n ($I_n = x I_r$)	OFF / 0.5/ 1.0/ 2.0 $\times I_r$
Time delay, t_r (Inverse)	As per Overload Curve Setting
Protection Mode	ON/OFF
Short Circuit	
Current Setting I_{sd} ($I_{sd} = x I_r$)	1.5, 3, 4.5, 5.5, 6, 7, 8.5, $10 \times I_r$
Time delay, t_s	100ms/200ms
I ² T	ON/OFF
Protection Mode	ON/OFF
Instantaneous	
Current Setting I_i ($I_i = x I_n$)	6 & 12 I_n
Protection Mode	ON/OFF
Earth Fault	
Current Setting I_g ($I_g = x I_n$)	0.2, 0.4, 0.5, 0.7 $\times I_n$
Time delay, T_g	100ms/200ms
Protection Mode	ON/OFF

Termination

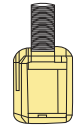
	DIRECT TERMINAL	Cable	2.5 mm to 25 mm ²
		Link	(11 to 16)mm wide x (2 to 5)mm thick
		Tightening Torque	max 6N-m at MCCB termination

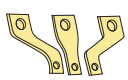
	BOX CLAMP #	Flexible	2.5 mm to 70 mm ²
		Rigid	2.5 mm to 95 mm ²
		Tightening Torque	max 6N-m at MCCB termination

	SPREADER #	Cable	25mm ² to 95mm ²
		Link	(16 to 25)mm wide x (3 to 6)mm thick
		Tightening Torque	max 6N-m at MCCB termination

	REAR TERMINAL #	Cable	95mm ²
		Link	(16 to 25)mm wide x (2 to 4)mm thick
		Tightening Torque	max 6N-m at MCCB termination

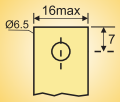
	# Basic Breaker is suitable for DIRECT termination. For all other types of termination + LINK / LUG width(W): 25 < W < 30mm
---	---

Plug-in Version

MCCBs with plug-in module are used in applications which demand higher levels of service continuity such as hospitals, process industries, automobile industry, etc. where immediate replacement is required. In such cases, MCCB with plug-in base can be safely removed from the system without removing the power connections or terminations and replaced with new MCCB.

Once MCCB is removed from the plug-in base, it offers complete isolation from the supply and maintains the safety of personnel working on down-stream feeders.



Features:

- ➔ Inbuilt safety interlock that prevents plugging in/out of MCCB when it is in ON condition
- ➔ Suitable for all types of terminations i.e. direct, spreader links, box clamps and rear terminals
- ➔ True position indication of MCCB - service or isolate
- ➔ Provision for both base mounting or 35 mm rail mounting
- ➔ Ingress Protection (IP):
 - IP20 – MCCB plugged out condition
 - IP40 – MCCB plugged in condition

Technical Datasheet

Frame		DZ1-160		
Type		D	N	
Current Range In (A)		16-160		
Release		TM(VTVM)/Microprocessor *		
Poles		3P/4P		
Impulse Withstand Voltage Uimp (kV)		8		
Rated Operational Voltage Ue (V AC) (MAX) @ 50 / 60 Hz		415		
Rated Operational Voltage Ue (V DC) (MAX)		500		
Rated Insulation Voltage Ui (V AC)		800		
Utilization Category		A		
Standard		IS 60947-2, IEC 60947-2, EN 60947-2		
Rated Short Circuit Breaking Capacity	Icu(kA)	220 / 230 V AC 50 / 60 Hz	45	65
		400 / 415 V AC 50 / 60 Hz	36	50
	Ics as % of Icu	220 / 230 V AC 50 / 60 Hz	100%	
		400 / 415 V AC 50 / 60 Hz	100%	
Making Capacity (kA) @ 415 V AC		75.6	105	
Life	Mechanical	30000		
	Electrical @ 415 V AC	10000		
Operating Frequency (Hz)		50/60		
Opening Time		< 10 msec		
Fingerproof Terminals		YES		
Suitable for Isolation		YES		
IP Class		IP20/IP40 [§] and IP54 with Extended ROM		
Pollution Degree		III		
Load-Line Bias		NO		
Ambient Temperature		- 5 °C to 55 °C		
Storage Temperature		- 15 °C to 70 °C		
Mounting Positions in Vertical Plane		Vertical and 90° in both directions		
Dimensions (H x W x D) (mm)	3 Pole	130 x 75 x 60		
	4 Pole	130 x 100 x 60		
Weight (kg) 3P/4P		0.9/1.1		
Accessories	Internal	Auxiliary Contact 1 C/O	01 no. Aux	
		Trip Alarm Contact 1 C/O	01 no. TAC	
		Shunt Release	01 no. Shunt or 01 no. UV	
		Under Voltage Release		
	External	Rotary Operating Mechanism(Direct/Extended)	✓	
		Mechanical Interlock Kit	✓	
		Spreader Terminals	✓	
		Rear Terminals [#]	✓	
		Box-Clamp [#]	✓	
		Plug-in [#]	✓	

*VTVM - Variable Thermal Variable Magnetic

*16 A to 50 A : Fixed Magnetic 375A

§ IP20 : At the Terminals, IP40: At Front Face

For details contact nearest branch office

Altitude Correction Factors

Altitude does not significantly affect circuit breaker characteristics upto 2000 m. Above this altitude, it is necessary to take into account the decrease in the dielectric strength and cooling capacity of air.

The following tables give the altitude correction factors for various circuit breaker characteristics :

Altitude Correction Factors		
Altitude	Rated Continuous Current (In)	Rated Voltage (Ue)
(m)	x (In)	x (Ue)
2000 & below	1.00	1.00
2500	0.99	0.95
3900	0.95	0.80

Altitude Correction Factors		
Altitude	Rated Insulation Voltage (Ui)	Rated Impulse Voltage (Uimp)
(m)	(V)	(kV)
2000 & below	800	8.0
2500	664	6.7
3900	560	5.6

Characteristic Curves

Trip Curves

Thermal Magnetic Release

iTMAF @12In

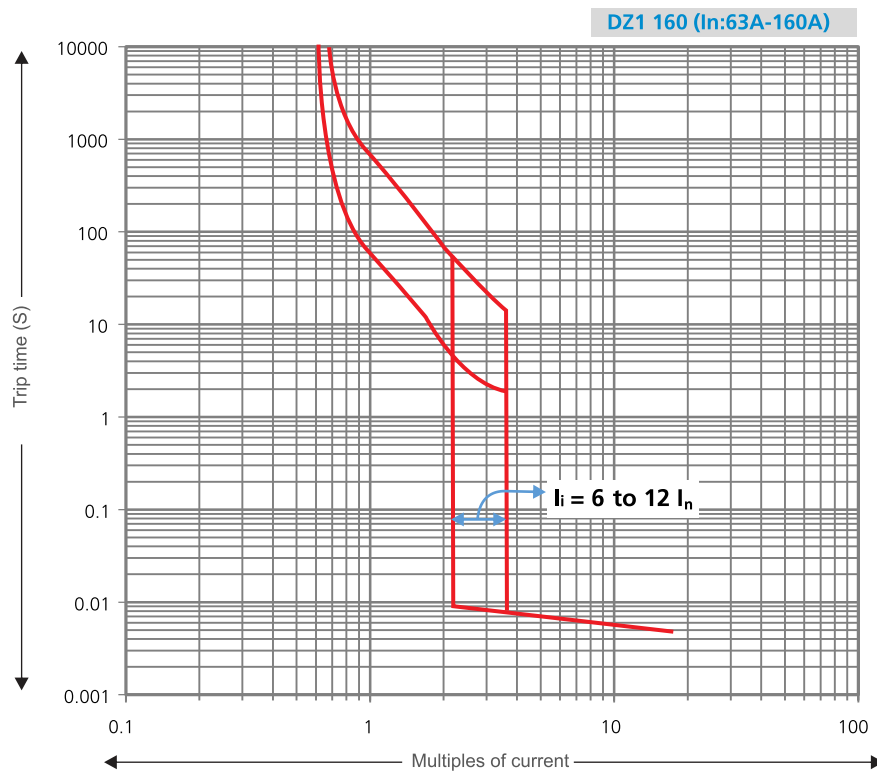
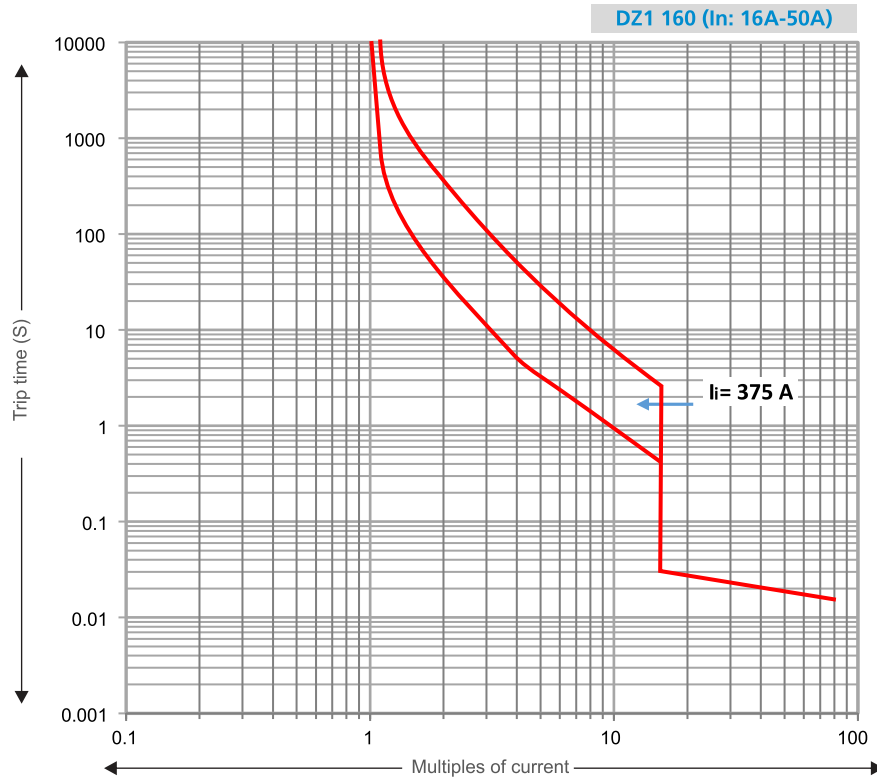

Microprocessor Release (*i*TRP)

Overload 6Ir @ 3s

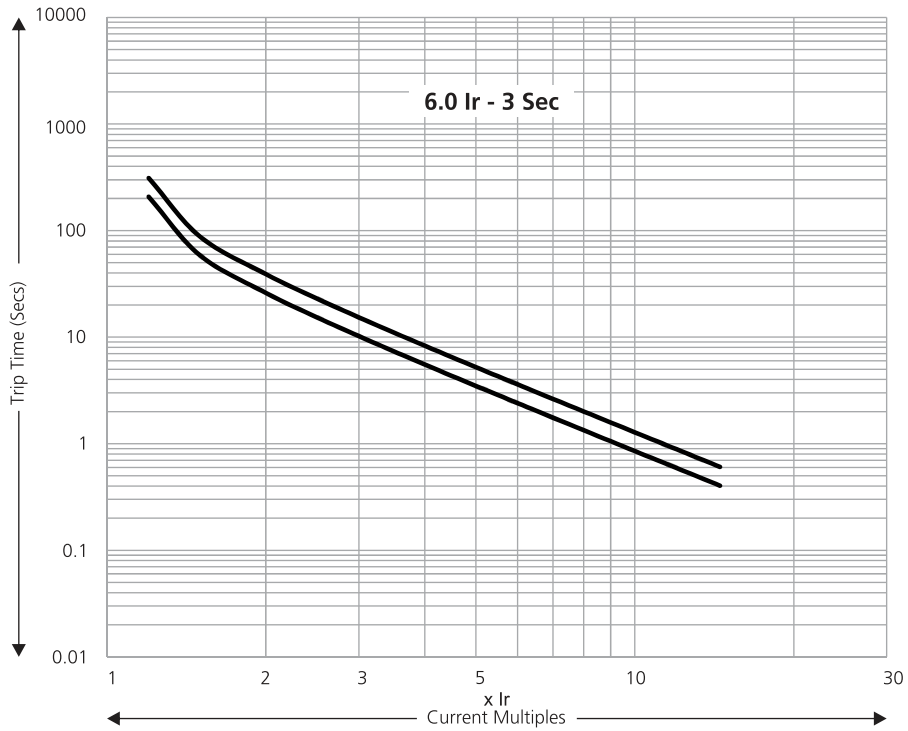

Overload 7.2Ir @ 3s

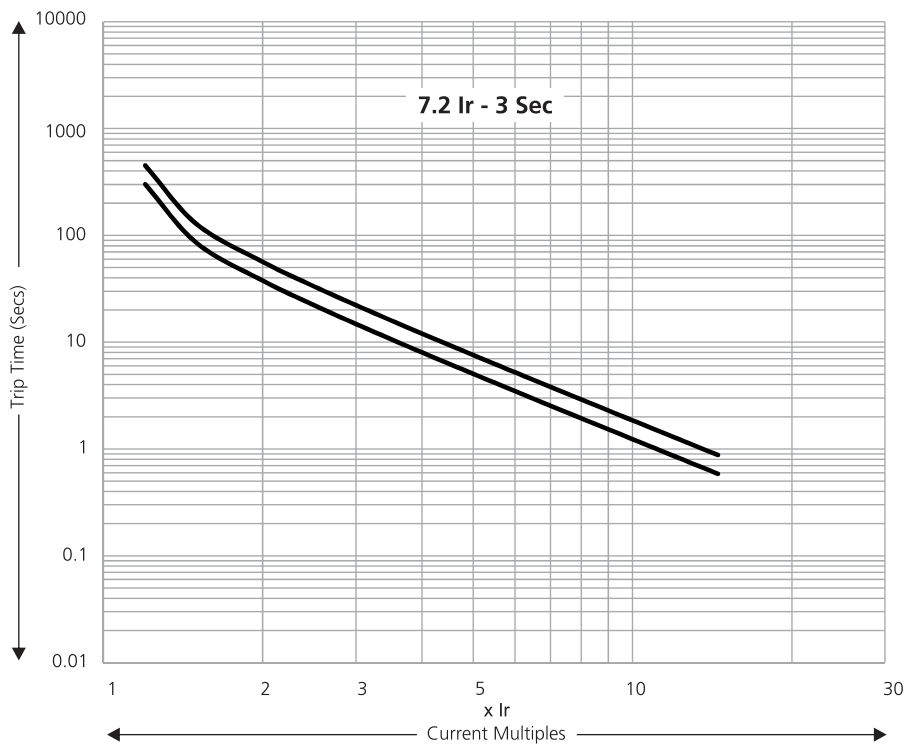

Overload 6Ir @ 10s

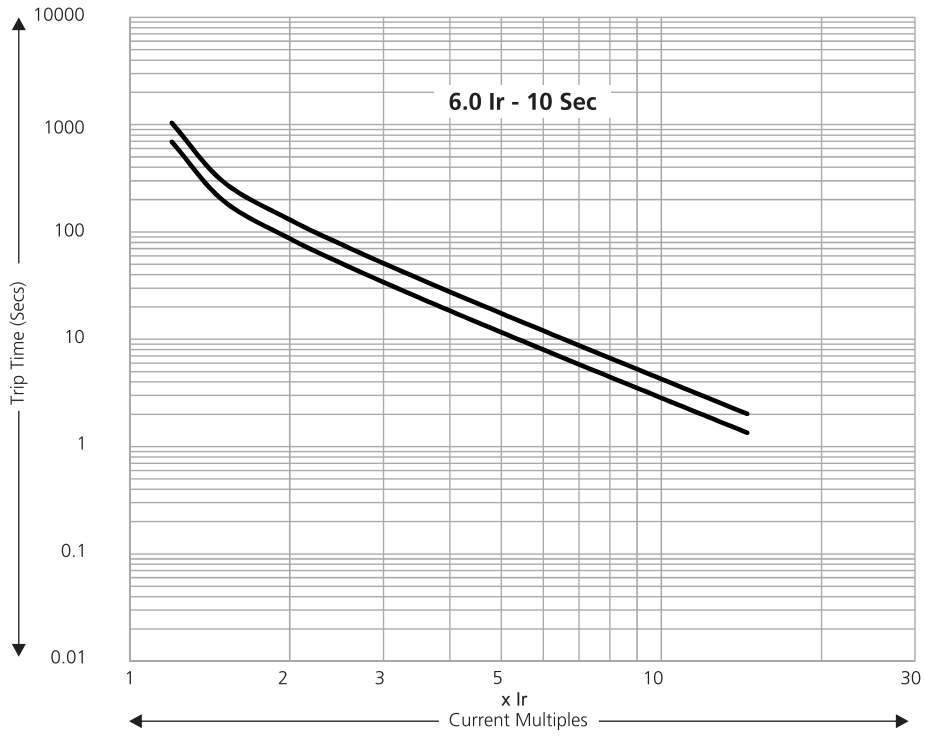

Overload 7.2Ir @ 10s

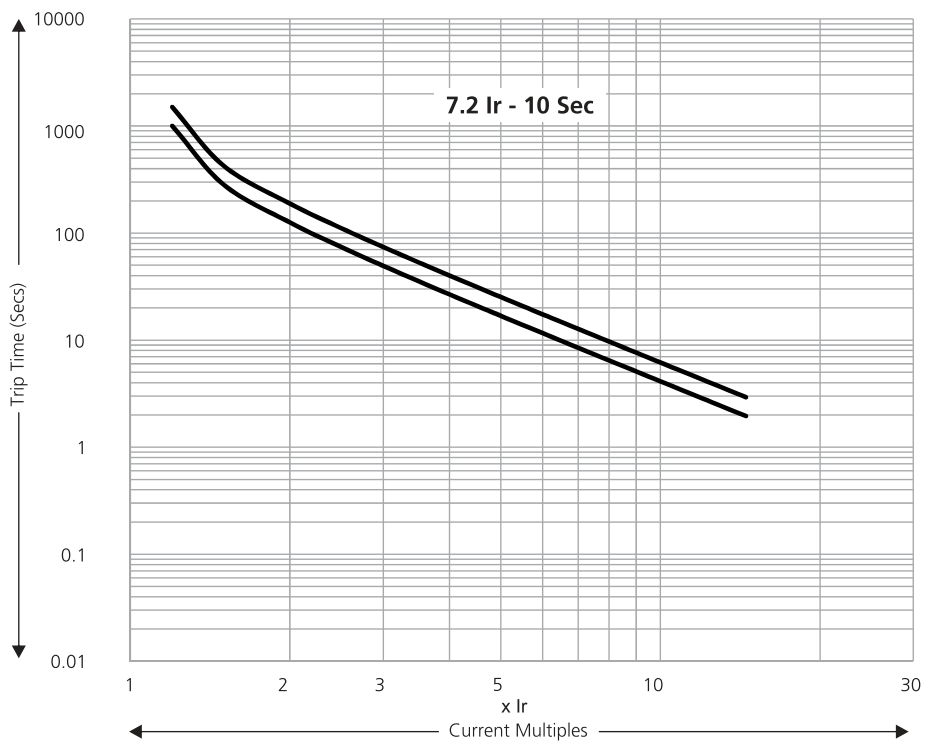

Short-Circuit & Instantaneous - *i* TRP-1

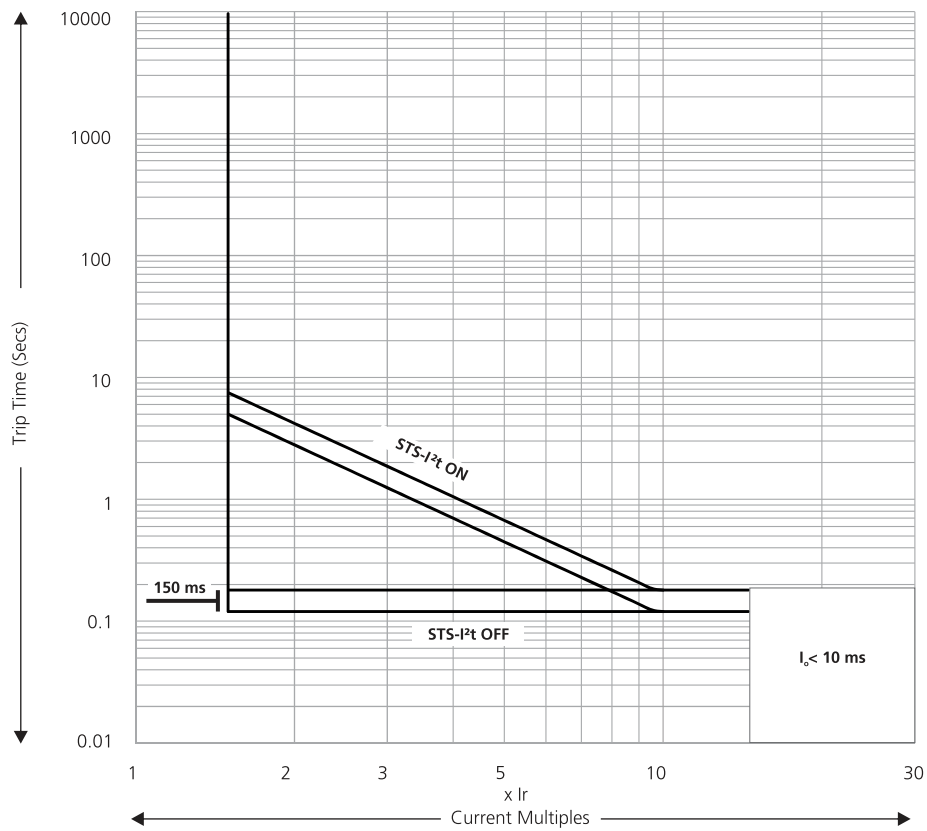

Short-Circuit & Instantaneous - *i* TRP-2 / *i* TRP-3

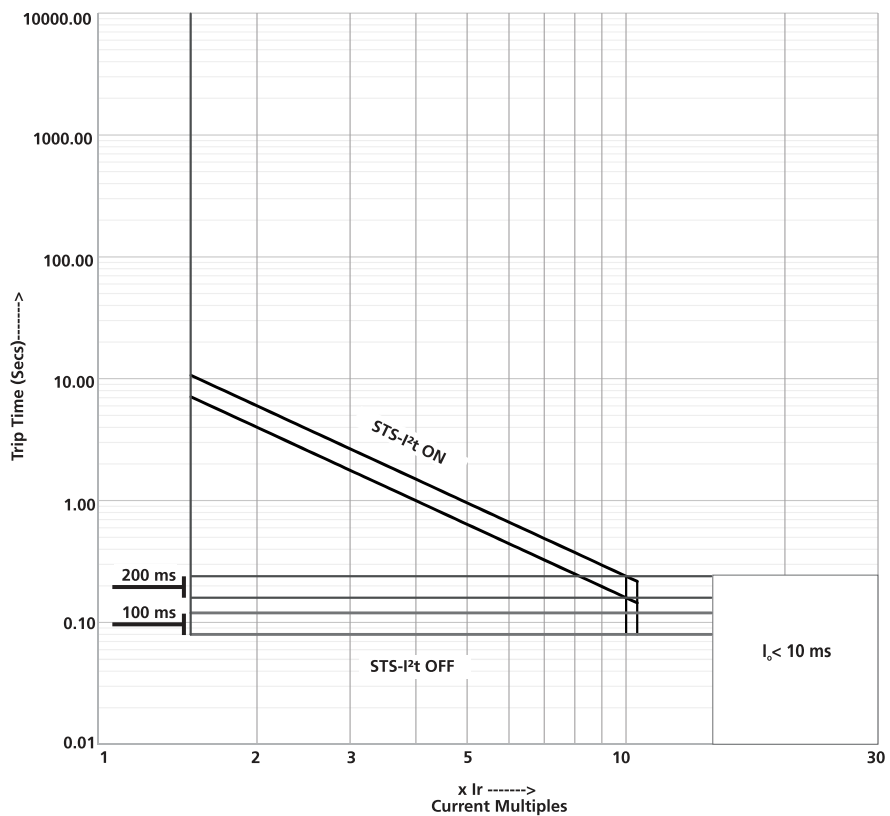

Earth Fault - *i* TRP-3

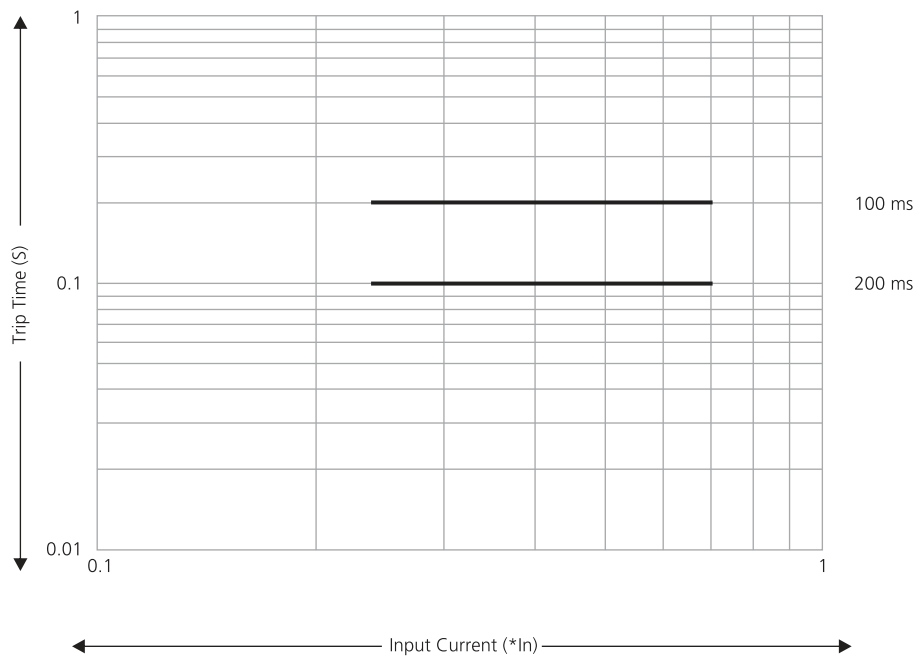

Current-Limiting Curve for d sine - DZ1 @ 415V

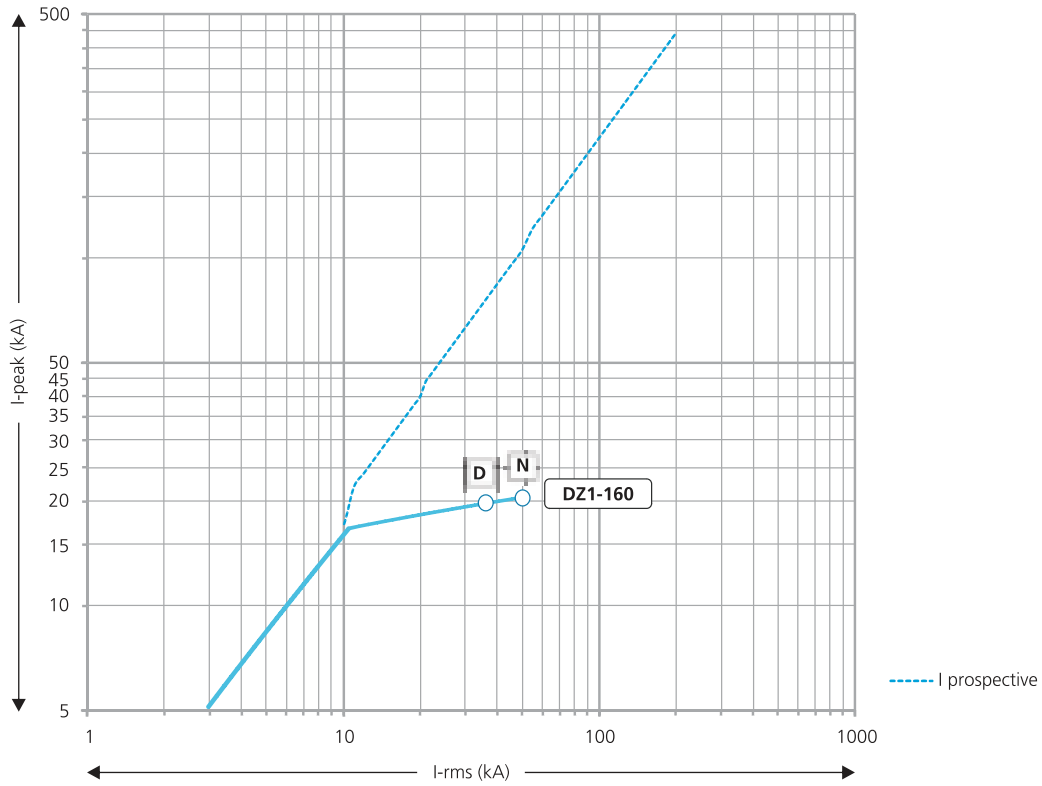

Energy-Limiting Curve for d sine - DZ1 @ 415V

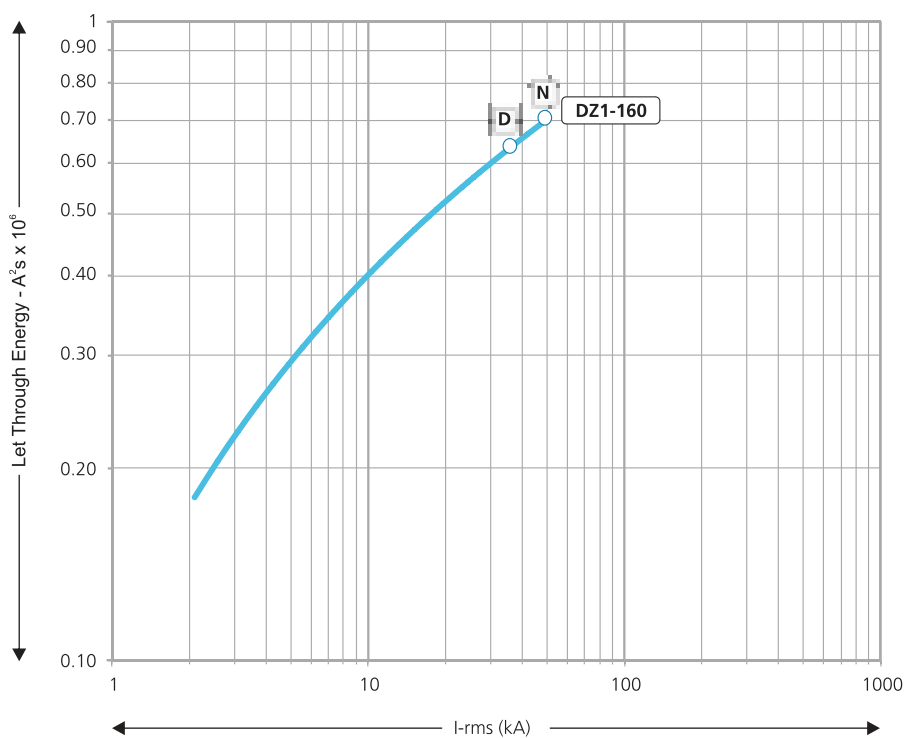

Overall Dimensions

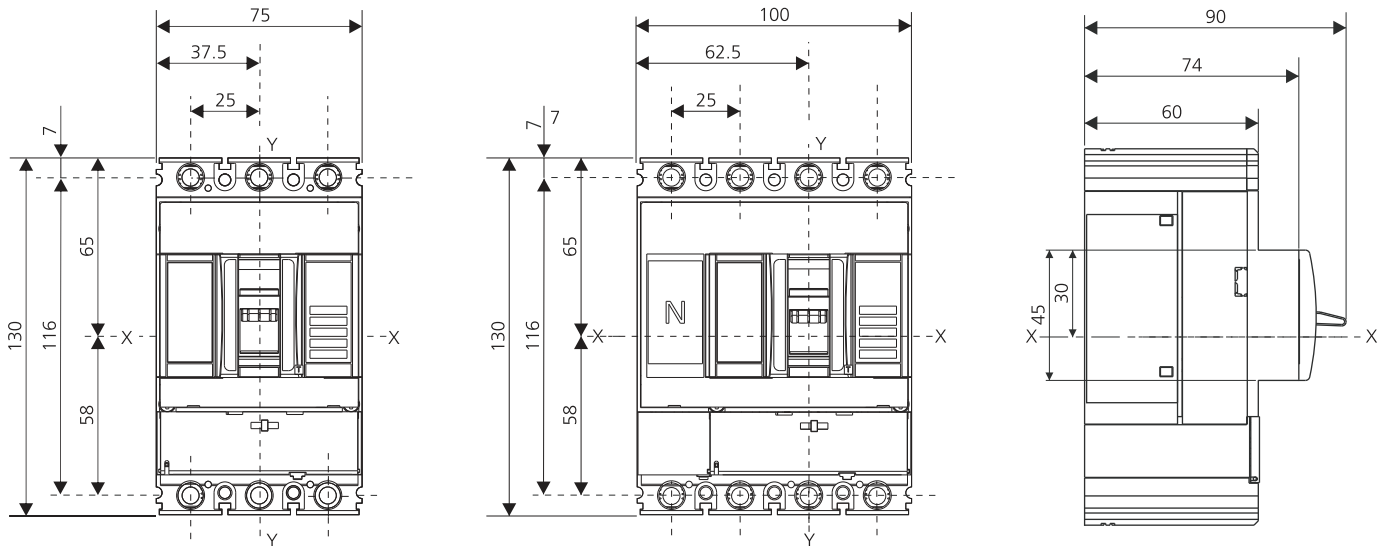

Overall Dimensions with Spreader Links

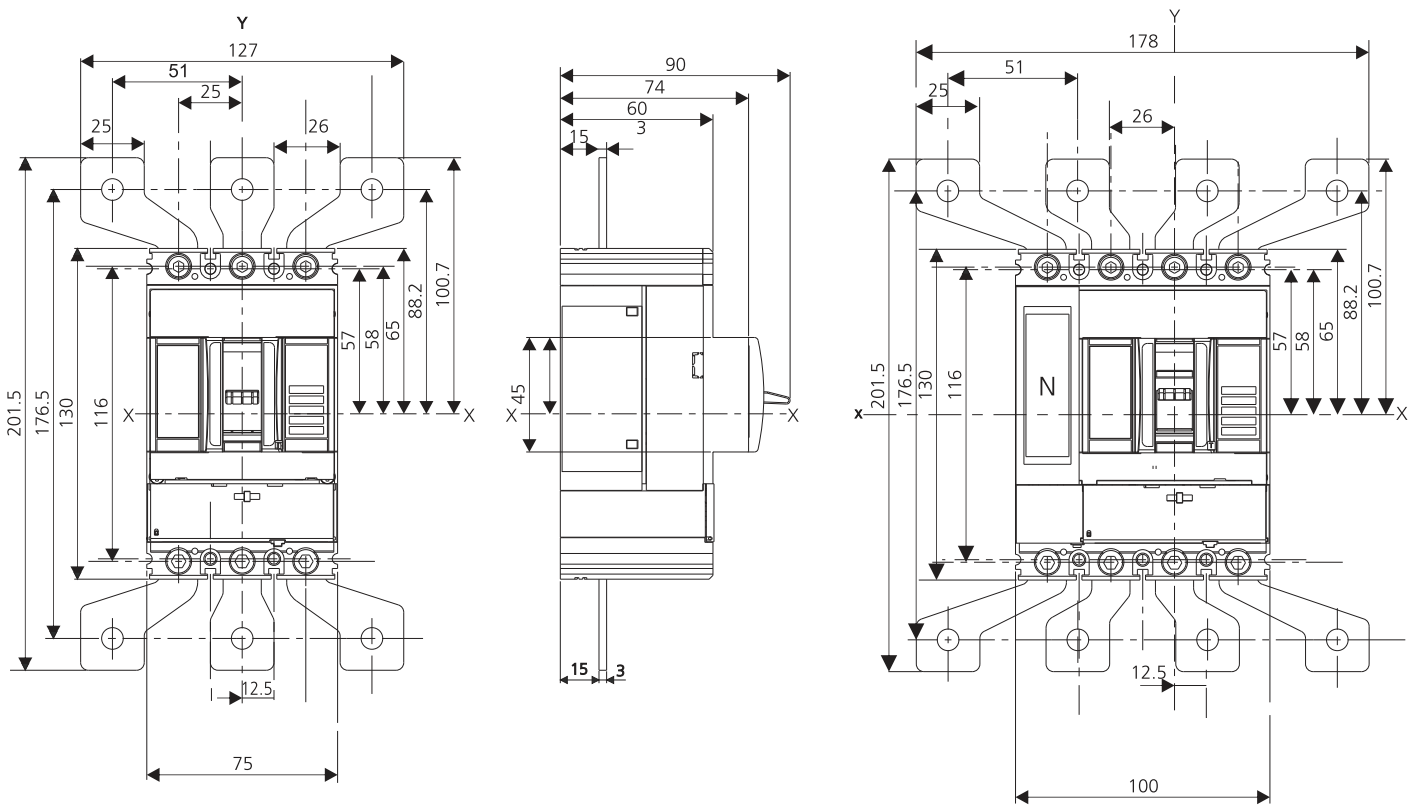

Mounting Dimensions

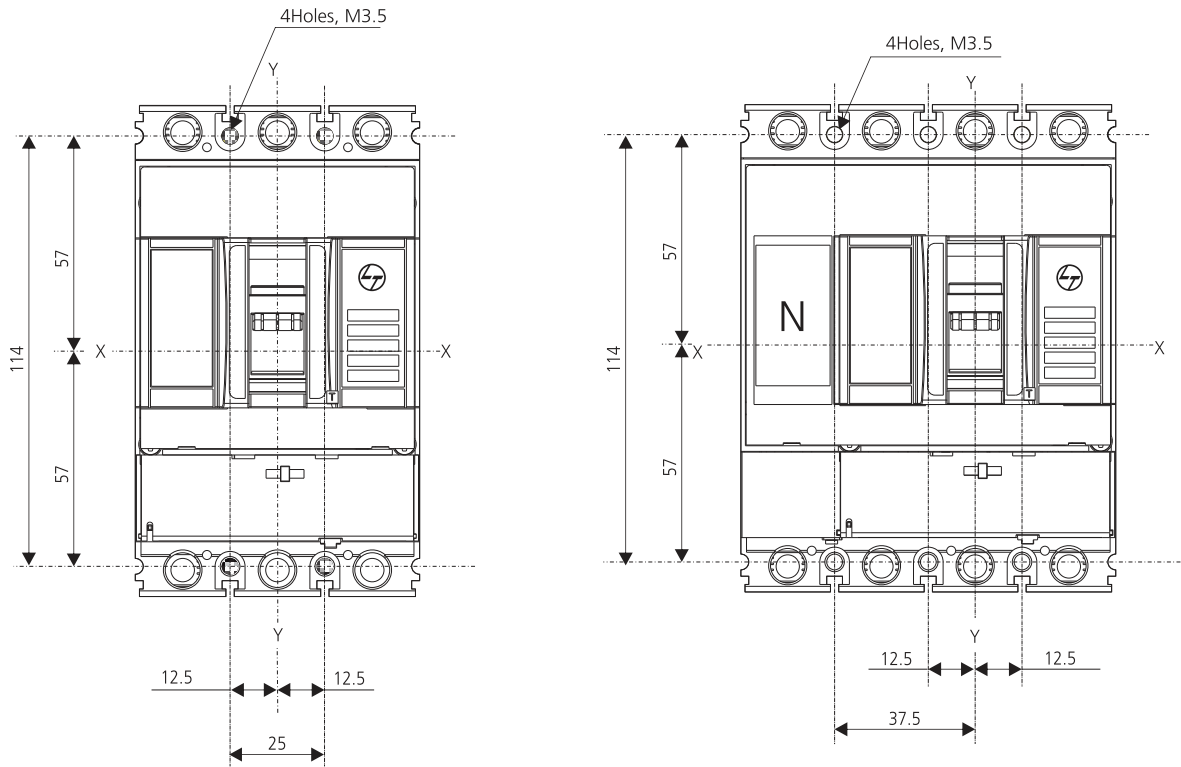

Panel Cutout

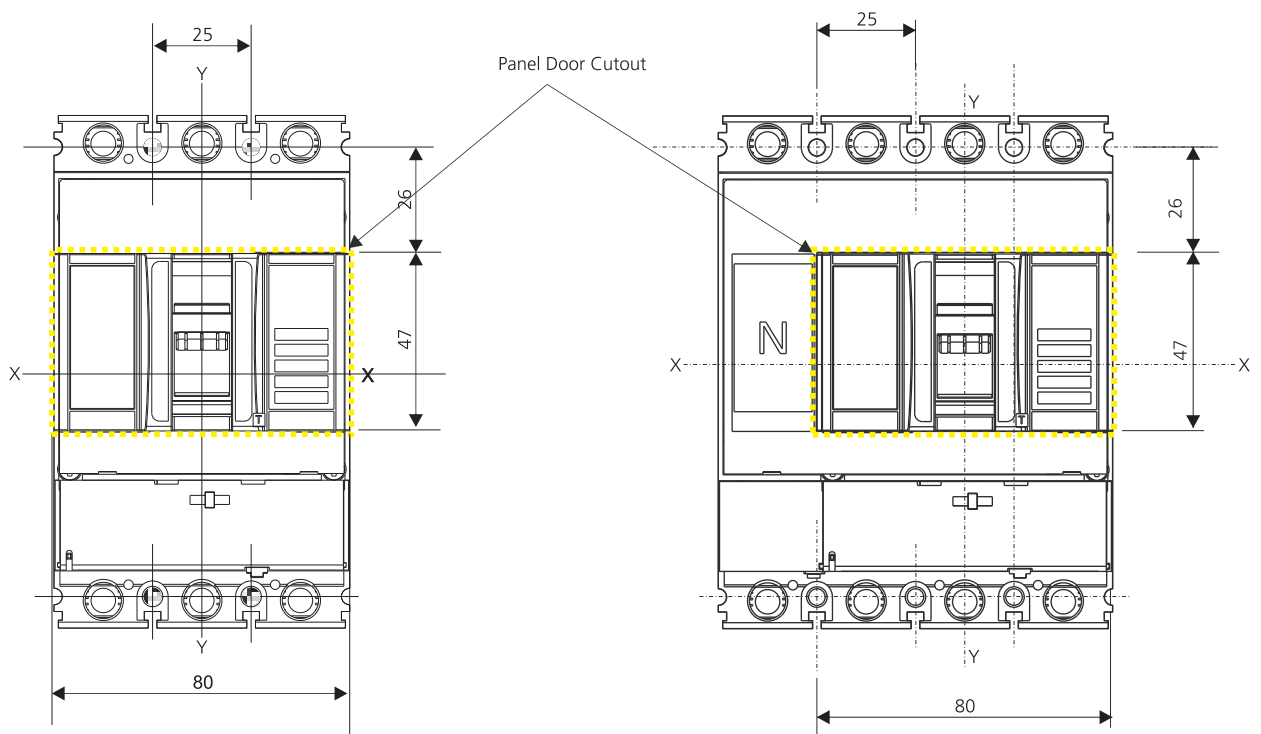

Accessories Dimensions

Direct ROM

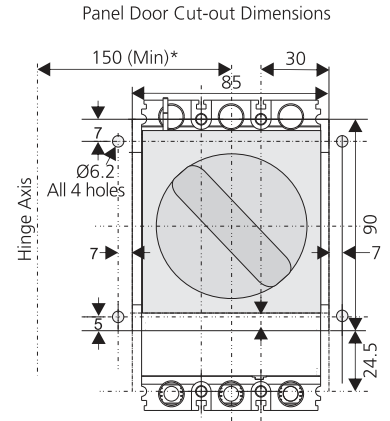
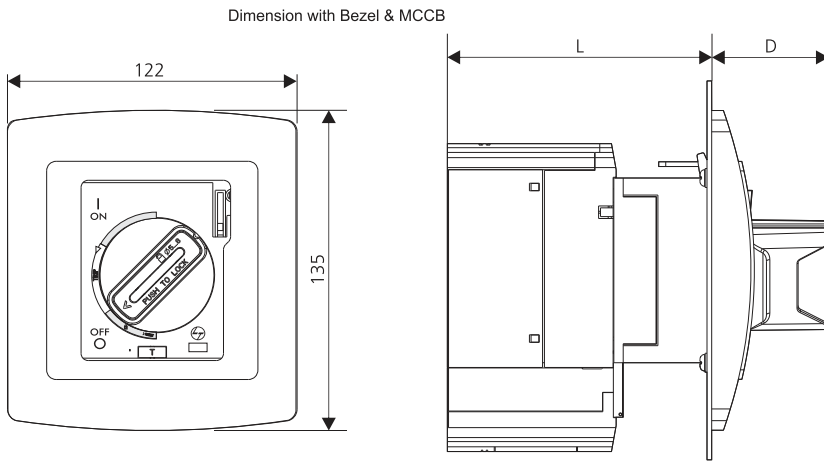

* Minimum hinge radius for Horizontal / Vertical MCCB installation

Frame	L	D
DZ 1	100.5	50

Extended ROM

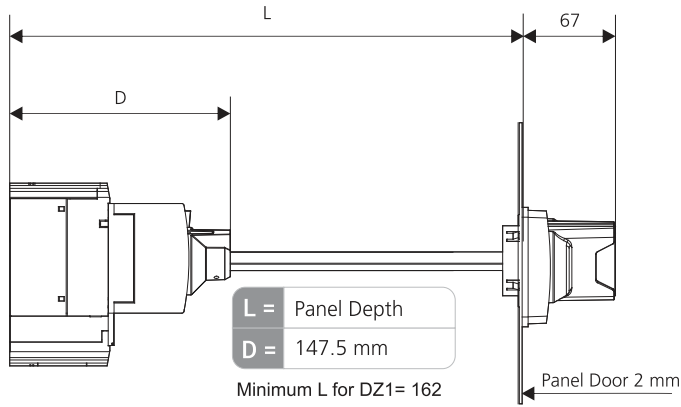

Vertical & Horizontal References with Respect to MCCB Mounting

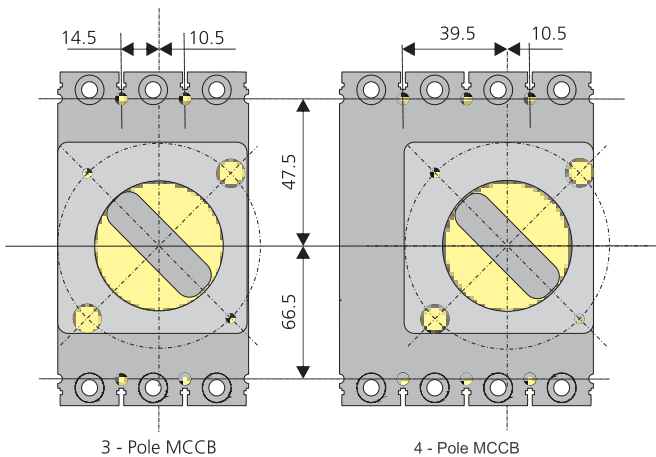

Panel Cut-out Details as Viewed from the Front

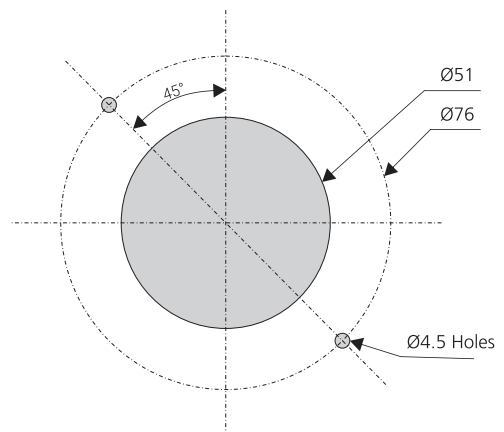

All dimensions are in mm

Plug-in type MCCBs

Overall Dimension

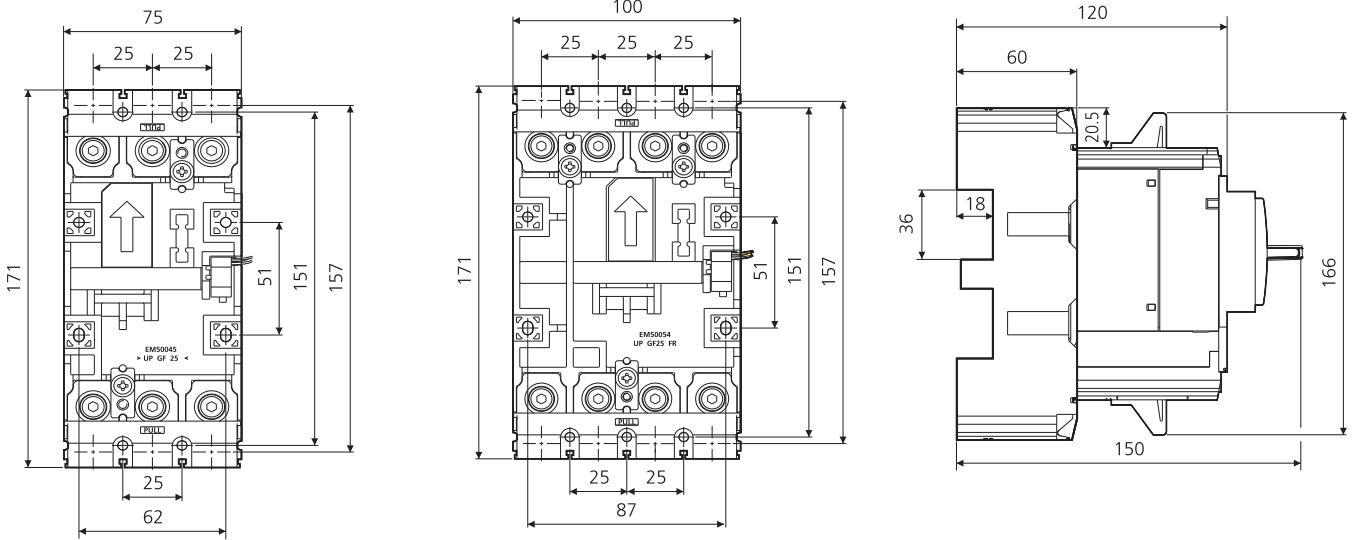

Spreader Dimension

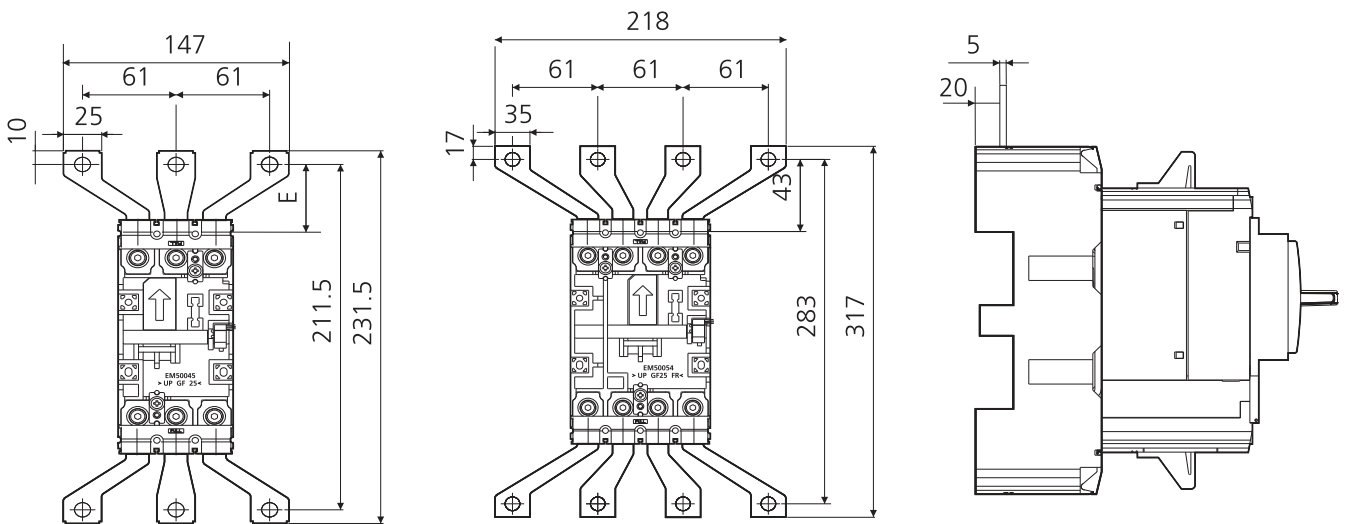

Type 2 Co-ordination Chart

Motor feeders are generally of two types- Fuse and Fuseless based on the type of short circuit protection device used. Fuse systems incorporate fuse whereas fuseless systems either make use of MCCB or MPCB. The MCCBs are available for various current ratings and kA levels depending on application. This offers you the flexibility of making the most apt selection as per your application. We have DZ1-M MCCBs which cater to motor back up application.

Selection Chart: Fuseless Protection for DOL Starter Feeders: IE2

Type '2' co-ordination, Iq=50 kA at 415V, 3Ø, 50 Hz as per IS/IEC 60947-4-1 standard

Sr. No.	Motor Ratings: 3Ø, 415V, 50 Hz			Contactor Type	Overload Relay			MCCB	
	hp	kW	FLC, In (A)		Type	Range (A)		Type	Rating (A)
1	50	37	68	MO 80	RTO-3	60	78	DZ1-160N (FM)	100
2	60	45	81	MO 95	RTO-3	75	110	DZ1-160N (FM)	100
3	75	55	94	MO 140	RTO-4	72	108	DZ1-160N (FM)	125
4	100	75	130	MO 250	RTO-4	105	156	DZ1-160N (FM)	160

Selection Chart: Fuseless Protection for DOL Starter Feeders: IE3

Type '2' co-ordination, Iq=50 kA at 415V, 3Ø, 50 Hz as per IS/IEC 60947-4-1 standard

Sr. No.	Motor Ratings: 3Ø, 415V, 50 Hz			Contactor Type	Overload Relay			MCCB	
	hp	kW	FLC, In (A)		Type	Range (A)		Type	Rating (A)
1	50	37	68	MO 80	RTO-3	60	78	DZ1-160N (FM)	100
2	60	45	81	MO 140	RTO-4	72	108	DZ1-160N (FM)	125
	75	55	94	MO 185	RTO-4	72	108	DZ1-160N (FM)	160

Electrical Standard Products (ESP) Offices:

HEAD OFFICE

L&T Electrical & Automation
L&T Business Park, TC2, Tower 'B'
3rd Floor, Gate No 5
Saki Vihar Road, Powai
Mumbai 400 072
Tel: 022-67052874 / 2737 / 1156
e-mail: cic@LNTEBG.com

BRANCH OFFICES

L&T Electrical & Automation
501, Sakar Complex I
Opp. Gandhigram Rly. Station
Ashram Road
Ahmedabad 380 009
Tel: 079-4900 4000 / 4010
e-mail: esp-ahm@LNTEBG.com

L&T Electrical & Automation
No 38, Cubbon Road
Bengaluru 560 001
Tel: 080-46136103 / 100
e-mail: esp-blr@LNTEBG.com

L&T Electrical & Automation
131/1, Zone II, Maharana Pratap Nagar
Bhopal 462 011
e-mail: esp-bho@LNTEBG.com

L&T Electrical & Automation
Plot No. 559, Annapurna Complex, 2nd Floor
Lewis Road
Bhubaneswar 751 014
Tel: 0674-2436690 / 9437453579 / 9437284376
e-mail: esp-bsr@LNTEBG.com

L&T Electrical & Automation
Aspire Towers, 4th Floor
Plot No. 55, Phase-I
Industrial & Business Park
Chandigarh 160 002
Tel: 0172-4646840 / 41 / 42 / 44 / 53
e-mail: esp-chd@LNTEBG.com

L&T Electrical & Automation
L&T Construction Campus
TC-1 Building, II Floor
Mount-Poonamallee Road
Manapakkam
Chennai 600 089
Tel: 044-2270 6800
e-mail: esp-maa1@LNTEBG.com

L&T Electrical & Automation
Electrical Standard Products
Manufacturing Facility
L&T Bypass Road, Malumichampatti
Coimbatore 641 050
Tel: 0422-6683031
e-mail: esp-cbe@LNTEBG.com

L&T Electrical & Automation
3rd Floor, 1&2 Vijay Park,
Main Chakrata road
Ballapur Chowk
Dehradun 248 001
Tel: +91 9582252411

L&T Electrical & Automation
Khairasol, Degaul Avenue
Durgapur 713 212
Tel: 0343-2540448 / 2540449 / 2540443
e-mail: esp-dgp@LNTEBG.com

L&T Electrical & Automation
5, Milanpur Road, Bamuni Maidan
Guwahati 781 021
Tel: +91 8876554417
e-mail: esp-ghy@LNTEBG.com

L&T Electrical & Automation
2nd Floor, Vasantha Chambers
5-10-173, Fateh Maidan Road
Hyderabad 500 004
Tel: 040-67015052
e-mail: esp-hyd@LNTEBG.com

L&T Electrical & Automation
Monarch Building, 1st Floor
D-236 & 237, Amrapali Marg
Vaishali Nagar
Jaipur 302 021
Tel: 0141-4385914 to 18
e-mail: esp-jai@LNTEBG.com

L&T Electrical & Automation
Akashdeep Plaza, 2nd Floor
P.O. Golmuri
Jamshedpur 831 003
Jharkhand
Tel: 0657-2340502 / 08
e-mail: esp-jam@LNTEBG.com

L&T Electrical & Automation
Skybright Bldg; M. G. Road
Ravipuram Junction, Ernakulam
Kochi 682 016
Tel: 0484-4409420 / 4 / 5 / 7 / 8754543994
e-mail: esp-cok@LNTEBG.com

L&T Electrical & Automation
3-B, Shakespeare Sarani
Kolkata 700 071
Tel: 033-48006001
e-mail: esp-kol@LNTEBG.com

L&T Electrical & Automation
No. 10, Fortuna Tower, 2nd Floor
Rana Pratap Marg, Near NBRI
Lucknow 226001
e-mail: esp-lko@LNTEBG.com

L&T Electrical & Automation
No. 73, Karpaga Nagar, 8th Street
K. Pudur
Madurai 625 007
Tel: 0452-2567405 / 2561068 / 2561657
e-mail: esp-mdu@LNTEBG.com

L&T Electrical & Automation
L&T Business Park, TC 2, Tower 'B'
3rd Floor, Gate No 5
Saki Vihar Road, Powai
Mumbai 400 072
Tel: 022-67052874 / 2737 / 1156
e-mail: esp-bom@LNTEBG.com

L&T Electrical & Automation
Unnati Building, 2nd Floor
Automation Campus
A-600, TTC Industrial area
Shil-Mahape road, Mahape
Navi Mumbai 400 710
Tel: 022-67226502 / 67226300

L&T Electrical & Automation
12, Shivaji Nagar
North Ambajhari Road
Nagpur 440 010
Tel: 0712-2260012 / 6606421
e-mail: esp-nag@LNTEBG.com

L&T Electrical & Automation
A-25, Imperia Complex, First Floor,
Mohan Cooperative Industrial Estate,
Near Sarita Vihar Metro Station,
Mathura Road
New Delhi 110 044
Tel: 011-42260600
e-mail: esp-del@LNTEBG.com

L&T Electrical & Automation
Grand Chandra, 2nd Floor
Fraser Road
Opposite Doordarshan Kendra
Patna 800 001
e-mail: esp-patna@LNTEBG.com

L&T Electrical & Automation
L&T House
P. O. Box 119
191/1, Dhole Patil Road
Pune 411 001
Tel: 020-48544395 / 48544279
e-mail: esp-pnq@LNTEBG.com

L&T Electrical & Automation
Crystal Tower,
4th Floor, G. E. Road
Telibandha
Raipur 492 006
Tel: +91 9755508228
e-mail: esp-raipur@LNTEBG.com

L&T Electrical & Automation
3rd Floor
Vishwakarma Chambers
Majura Gate, Ring Road
Surat 395 002
Tel: 0261-2473726
e-mail: esp-sur@LNTEBG.com

L&T Electrical & Automation
Radhadaya Complex
Old Padra Road
Near Charotar Society
Vadodara 390 007
Tel: 0265-6613610 / 1 / 2
e-mail: esp-bar@LNTEBG.com

L&T Electrical & Automation
Door No. 49-38-14/3/2, 1st Floor
NGGO'S Colony, Akkayyapalem,
Visakhapatnam 530 016
Tel: 0891-2791126 / 2711125
e-mail: esp-viz@LNTEBG.com

Product improvement is a continuous process, For the latest information and special application, please contact any of our offices listed here. Product photographs shown for representative purpose only.



L&T Electrical & Automation, Electrical Standard Products
L&T Business Park, TC-2, Tower B, 3rd Floor, Gate No. 5, Saki Vihar Road, Powai,
Mumbai - 400 072, INDIA www.Lntebg.com

Customer Interaction Centre (CIC)
BSNL/MTNL (toll-free): 1800 233 5858 Reliance (toll-free): 1800 200 5858
Tel: 022 6774 5858 Email: cic@Lntebg.com Web: www.Lntebg.com