

SIEMENS

Ingenuity for life



Betagard

5SV residual current operated circuit breakers

New portfolio for reliable personnel, material
and fire protection

www.siemens.co.in

Siemens Residual Current Circuit Breaker

Protecting Lives for more than 20 years!!!

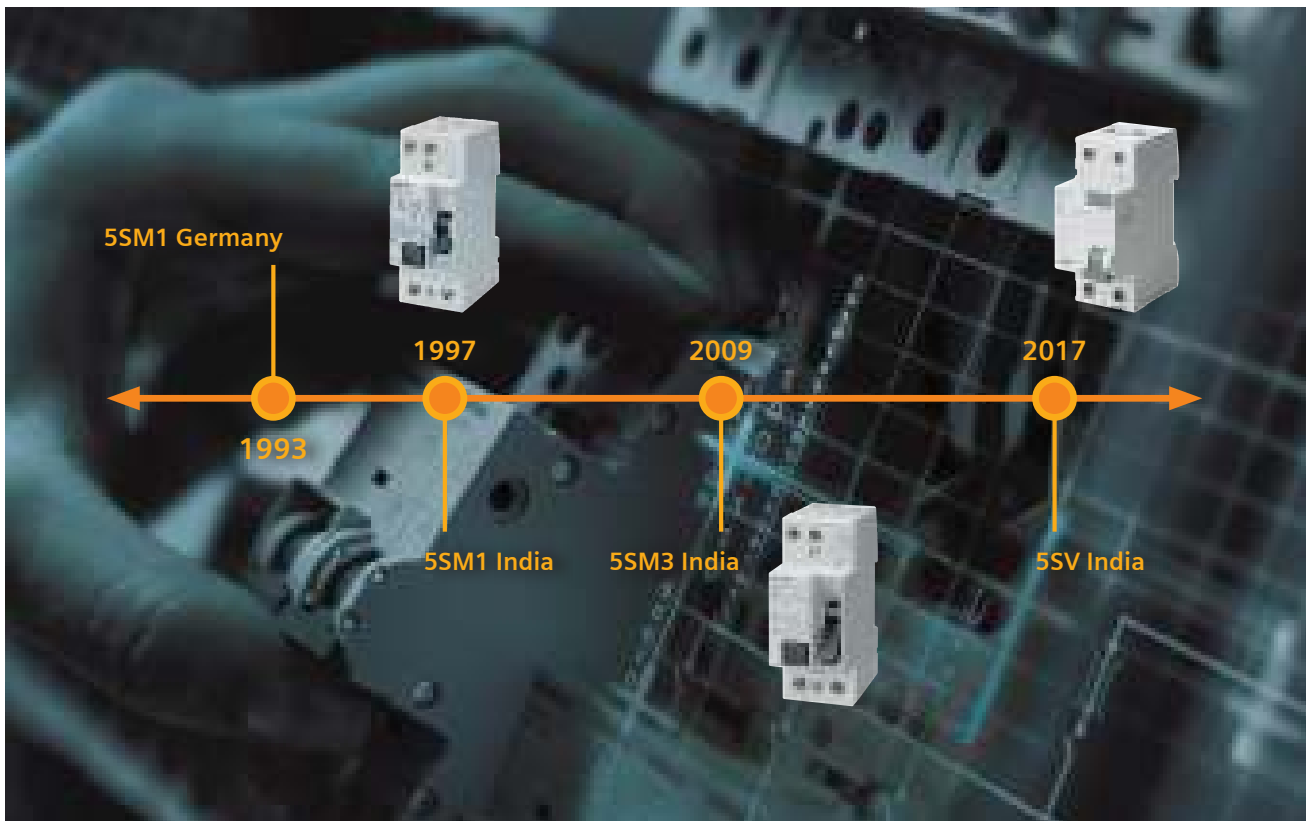

Coming Soon!!!

Super resistant **K**

Super resistant (short-time delayed) RCCBs meet the maximum permissible break times for instantaneous devices. However, by implementing a short-time delay they prevent unnecessary tripping operations, and thus plant faults, when pulse-shaped leakage currents occur – as is the case when capacitors are switched on.

Selective **S**

Can be used as upstream group switch for selective tripping contrary to downstream, instantaneous or short-time delayed RCCBs.

Safe protection against residual currents

Residual current protective devices are used for personnel, material and fire protection. This protects human lives and prevents electrical fires, which arises due to unwanted electric leakages.

The new model for more convenience

The improved design of the residual current protective devices with a separate switch position indicator and a handle imprint provides greater safety and ease-of-use. They are also suitable for the quick and easy mounting of additional components such as auxiliary switches, fault signal contacts, shunt trips and undervoltage releases.

Easy and safe installation

The new 5SV residual current operated circuit breaker can be released quickly and easily from the bus-mounted assembly with the help of the latching slide – no other tool is required.

Enhanced features

The new 5SV residual current operated circuit breakers with ISI and CE marking has Conditional Short Circuit withstand capability of 10kA, has Unique square terminal design, colourful/ printed ON/OFF lever indication and is made up of FR Grade housing material.

Highlights

- ISI and CE marking
- Unique square terminal design
- RoHS compliant
- Service life >10000 cycles or >20000 operations
- Uniform and comprehensive accessories for further functions
- SLR feature for easy removal of a single device from the busbar mounted assembly
- More convenience and safety through an improved design
- Uniform and comprehensive accessories for further functions
- Consistent busbar concept for all residual current protective devices
- Easy removal of a single device from the busbar-mounted assembly

Overview

Residual current protective devices are used in all supply systems up to 240/415 V AC. Devices of type AC trip in the event of sinusoidal AC residual currents, type A also trips in the event of pulsating DC residual currents.

RCCBs with rated residual current of 30mA offers the highest level of protection to human and animal life against direct and indirect contact with live parts and is recommended for residential, commercial and industrial premises, power sockets, schools, hotels etc, wet areas and during temporary construction installation.

RCCBs with rated residual current of 100mA normally provides protection only against indirect contact and hence protects both the entire wiring system and components e.g. in buildings, laboratories, industry, workshops etc. for faults caused through misuse, accidental damage or appliance failure.

The 300mA RCCBs are used where only fire protection is required and risk of electric shock is small. It is normal to use 300mA as incomer and subsequent 30mA/100mA protective RCCBs in the downstream circuit

Since the introduction of DIN VDE 0100-410, all socket outlet current circuits up to 20 A must also be fitted with residual current protective devices with a rated residual current of max. 30 mA. This also applies to outdoor electrical circuits up to 32 A for the connection of portable equipment.

Devices with a rated residual current of maximum 300 mA are used as preventive fire protection in case of insulation faults. RCCBs with a rated residual current of 100 mA are primarily used outside.

Benefits

- Instantaneous residual current operated circuit breakers enable simple bus mounting with standard pin busbars.
- Type "A" Have a surge current withstand capability with current waveform 8/20µs of more than 1 kA.
- Auxiliary switches, fault signal contacts, undervoltage releases and shunt trips are also available as additional components.
- Effective touch protection is provided to avoid accidental contact when grasping and manually operating the latching slide.
- To facilitate entry of pin busbars with connection cables up to 35 mm², the devices are equipped with rectangular terminals for the accommodation of funnel-shaped cable entries.
- Due to standardized spacing of the terminals in modular width dimensions, the RCCBs and MCBs can be optionally connected to busbars on the top or on the bottom.
- Better aesthetic appeal as design uniformity confirms with 5SL MCB – and additional indication window for type A



Residual Current Protective Devices

5SV RCCBs

Technical specifications



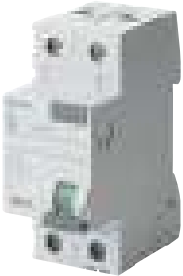
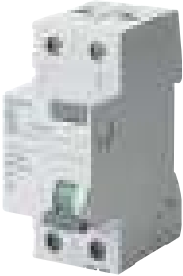



		Instantaneous
Standards		IS 12640 Part 1, IEC/EN 61008, VDE 0664 Part 10, IEC/EN 61543, VDE 0664 Part 30
Versions		DP and FP
Rated Voltage U_n	V AC	240V/415V
Rated Current I_n	A	25, 40, 63, 80
Rated Residual Current $I_{\Delta n}$	mA	30, 100, 300
Surge Current Withstand capacity of RCCBs		1 kA with current waveform 8/20us
Conditional Short Circuit withstand capacity		10kA
Minimum operational voltage for test function operation		
• 30-mA devices	V AC	195
• Non-30-mA devices	V AC	100
• 24 V devices	V AC	20
Test cycles		1/2 year
Insulation coordination		
• Overvoltage category		III
Pollution degree		2
Terminal conductor cross-sections		
• 1-wire		
- Solid ($\leq 10 \text{ mm}^2$) / stranded ($\geq 16 \text{ mm}^2$)	mm ²	0.75 ... 25
- Finely stranded with non-insulated end sleeve	mm ²	0.75 ... 25
- Finely stranded with insulated end sleeve	mm ²	0.75 ... 25
- Finely stranded without end sleeve	mm ²	1 ... 25
• 2-wire, same cross-section, same conductor type		
- Solid ($\leq 10 \text{ mm}^2$) / stranded ($\geq 16 \text{ mm}^2$)	mm ²	0.75 ... 10
- Finely stranded with non-insulated end sleeve	mm ²	0.75 ... 4
- Finely stranded with insulated end sleeve	mm ²	0.75 ... 4
- Finely stranded without end sleeve	mm ²	1 ... 4
• 1-wire + busbar (pin thickness 1.5 mm)		
- Solid ($\leq 10 \text{ mm}^2$) / stranded ($\geq 16 \text{ mm}^2$)	mm ²	10 ... 25
- Finely stranded with non-insulated end sleeve	mm ²	6 ... 25
- Finely stranded with insulated end sleeve	mm ²	6 ... 16
Terminal tightening torque		
• Up to $I_n = 80 \text{ A}$	Nm	2.5
• At $I_n = 100 \text{ A}, 125 \text{ A}$	Nm	3.0 ... 3.5
Mains connection		Top or bottom
Rated frequency	Hz	50
Mounting position (on a standard mounting rail)		Any
Degree of protection	Acc. to EN 60529 (VDE 0470-1)	IP20, if the distribution board is installed, with connected conductors
Touch protection	Acc. to EN 50274 (VDE 0660-514)	Finger and back-of-hand safe
Service life	Average number of operating cycles Test cycle acc. to IEC/EN 61008	> 10000
Storage temperature	°C	-40 ... +75
Ambient temperature	°C	-25 ... +45, marked with 
Resistance to climate	Acc. to IEC 60068-2-30	28 cycles (55 °C; 95 % rel. air humidity)
CFC and silicone-free		Yes

Selection and ordering data

	Rated residual current	Rated current	Max. permissible short-circuit back-up fuse	Mounting width	MLFB
	$I_{\Delta n}$	I_n			
	mA	A	A	MW	
RCCBs, type A, instantaneous					
	1P+N; 230 V AC; 50 Hz				
	30	25	63	2	5SV33126RC
		40	63		5SV33146RC
		63	100		5SV33166RC
		80	100		5SV33176RC
	100	25	63	2	5SV34126RC
		40	63		5SV34146RC
		63	100		5SV34166RC
		80	100		5SV34176RC
	300	25	63	2	5SV36126RC
		40	63		5SV36146RC
		63	100		5SV36166RC
80		100	5SV36176RC		
	3P+N; 415 V AC; 50 Hz				
	30	25	80	4	5SV334126RC
		40	80		5SV334146RC
		63	100		5SV334166RC
		80	100		5SV334176RC
	100	25	80	4	5SV344126RC
		40	80		5SV344146RC
		63	100		5SV344166RC
		80	100		5SV344176RC
	300	25	80	4	5SV364126RC
		40	80		5SV364146RC
		63	100		5SV364166RC
80		100	5SV364176RC		
RCCBs, type AC, instantaneous					
	1P+N; 230 V AC; 50 Hz				
	30	25	63	2	5SV43120RC
		40	63		5SV43140RC
		63	80		5SV43160RC
		80	80		5SV43170RC
	100	25	63	2	5SV44120RC
		40	63		5SV44140RC
		63	100		5SV44160RC
		80	100		5SV44170RC
	300	25	63	2	5SV46120RC
		40	63		5SV46140RC
		63	100		5SV46160RC
80		100	5SV46170RC		
	3P+N; 415 V AC; 50 Hz				
	30	25	80	4	5SV43420RC
		40	80		5SV43440RC
		63	100		5SV43460RC
		80	100		5SV43470RC
	100	25	80	4	5SV44420RC
		40	80		5SV44440RC
		63	100		5SV44460RC
		80	100		5SV44470RC
	300	25	80	4	5SV46420RC
		40	80		5SV46440RC
		63	100		5SV46460RC
80		100	5SV46470RC		

Residual Current Protective Devices

5SV RCCBs

Type of current	Current waveform	Correct function of residual current protective devices of type		Tripping current ¹⁾
		Type AC 	Type A 	
AC residual current		✓	✓	$0.5 \dots 1.0 I_{\Delta n}$
Pulsating DC residual currents (pos. or neg. half-waves)		–	✓	$0.35 \dots 1.4 I_{\Delta n}$
Started half-wave currents Start angle 90° el Start angle 135° el		–	✓ ✓	$0.25 \dots 1.4 I_{\Delta n}$ $0.11 \dots 1.4 I_{\Delta n}$
Half-wave current during superimposition with smooth direct current of 6 mA		–	✓	$\text{max. } 1.4 I_{\Delta n} + 6 \text{ mA}$
Smooth direct current		–	–	$0.5 \dots 2.0 I_{\Delta n}$

¹⁾ Tripping currents according to IEC/EN 61008-1 (VDE 0664, Part-10);
for smooth DC residual currents defined to IEC 60755 UB1 INT.

Dimensional drawings

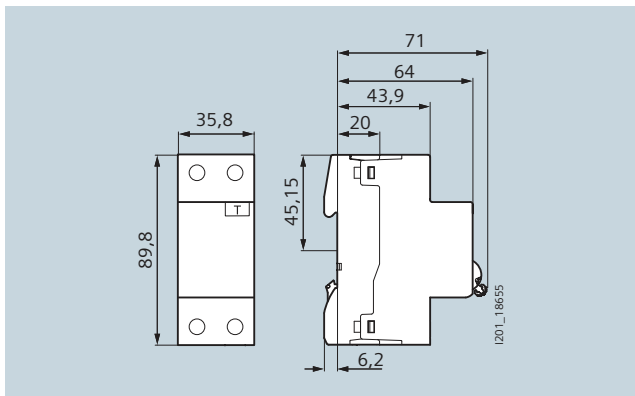

RCCBs, type A and type AC
1P+N, 2 MW

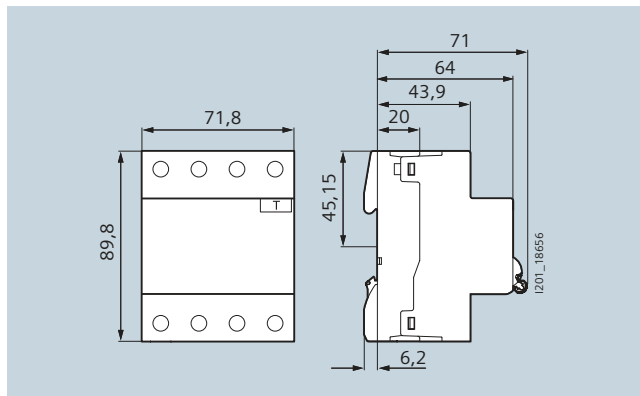

RCCBs, type A and type AC
3P+N, 4 MW

Circuit diagrams

Graphic symbols

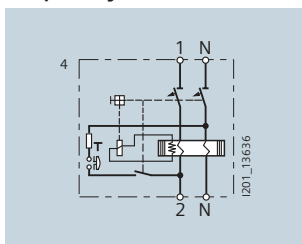



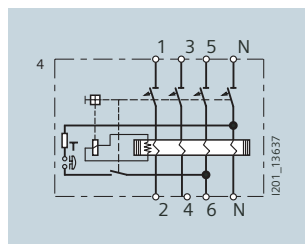



1P+N



3P+N

Selection and ordering data

		Rated voltage	Mounting width	MLFB	
 5ST3010	Auxiliary switches (AS)		0.5		
	1 NO + 1 NC For low power				5ST3010 5ST3013
	2 NO For low power				5ST3011 5ST3014
	2 NC For low power				5ST3012 5ST3015
 5ST3020	Fault signal contacts (FC)		0.5		
	1 NO + 1 NC				5ST3020
	2 NO				5ST3021
	2 NC				5ST3022
 5ST3040	Undervoltage releases (UR)		1		
	With integrated auxiliary switch	230 AC			5ST3040
		110 DC			5ST3041
		24 DC			5ST3042
	Without integrated auxiliary switch	230 AC			5ST3043
		110 DC			5ST3044
24 DC		5ST3045			
 5ST3030	Shunt trips (ST)				
	For 5SY, 5SP miniature circuit breakers, 5SV residual current protective devices and 5SU1 RCBOs				
	110 ... 415 V AC	1			5ST3030
	24 ... 48 V AC/DC	1			5ST3031
	Handle locking devices			5ST3806	
	<ul style="list-style-type: none"> • For 5SV RCCBs • Sealable • For padlock with 3 ... 6 mm shackle 				
 5ST3802	Padlocks			5ST3802	