

TemBreak

- New compact breakers -



The Ultimate
Safety Breaker

TABLE OF CONTENTS

1. Ratings and Specifications 1-1	
Molded Case Circuit Breakers	
z Fixed thermal and fixed magnetic MCCBs 1-2	c Switch-disconnectors 1-4
x Adjustable thermal and adjustable magnetic MCCBs 1-3	
2. Mounting and Connection 2-1	
z Type of connections and mountings 2-2	c Terminal screw sizes and standard torques 2-6
List of connecting type 2-2	v Insulation distance from the line side 2-7
Connecting parts 2-3	b Reverse connection 2-8
x Compression terminals 2-4	n Lists of breaker mounting screws 2-8
3. Accessories 3-1	
z Internally mounted accessories 3-2	x Externally mounted accessories 3-6
1. Connection diagrams and terminal numbers 3-2	1. Motor operators (MC) 3-6
2. Possible combinations 3-2	2. Toggle holder (HH) and toggle lock (HL) 3-9
3. Ratings and operation data of auxiliary and alarm switches 3-3	3. External operating handles 3-10
4. Shunt trip device (SHT) 3-3	(1) Breaker-mounted (HB) for E100 3-10
5. Undervoltage trip device (UVT) 3-4	(2) Breaker-mounted (field installable)(HB) for S160, E250, S250 3-12
	(3) Door-mounted (depth adjustable) (HS) standard type ... 3-16
	(4) Door-mounted (depth adjustable) (HP) ordinal type 3-20
	4. Interpole barriers (BA) 3-25
	5. Terminal covers CF/CR/CS 3-26
	(1) CF for front-connected breakers 3-26
	(2) CR for rear-connected and plug-in breakers CS for front-connected breakers with cable clamps 3-27
	6. Terminal blocks (TF) 3-28
	7. Mechanical interlock 3-30
	• Slide interlock (MS) 3-30
	8. Door Flange (DF) 3-33
4. Characteristics and Outline Dimensions 4-1	
• E100-SF 4-2	• S160-SCJ, S160-SJ 4-10
• E160-SF 4-4	• E250-SJ, S250-SJ 4-12
• S160-SCF, S160-SF 4-6	• S160-SN 4-14
• E250-SF, S250-SF 4-8	• S250-SN 4-16

1

2

3

4

FEATURES

Saving space and saving money !

No. 4
Operation in pollution degree 3 to IEC standard

No. 1
Compact size: W76 H130 D68;
and high breaking capacity: 40kA
415V (S160-SF/SJ)

No. 6
IP20 protection for the terminals
and IP30 protection for the front cover
with toggle (with terminal covers)

No. 9
Two alarm switches can be easily installed

No. 7
Unique accessory cover opens with
only one screw

No. 8
Practical internal accessories can
be installed with one touch
- auxiliary switch
- alarm switch
- shunt trip
- undervoltage trip

No. 5
Suitable for isolation
with positive contact
indication

No. 3
Unlimited performance
when reverse-connected

No. 2
Huge adjustment
range for overload
protection: 63 to 100%
Dial cover can be
sealed.
(Adjustable thermal
MCBs)

No. 10
Secure accessory cover
returns nameplate

VARIED TERMINATIONS

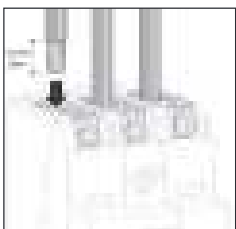

cable clamp

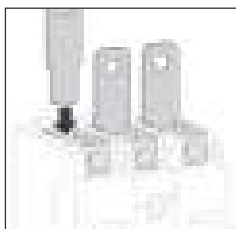

straight extension bar



spread extension bar

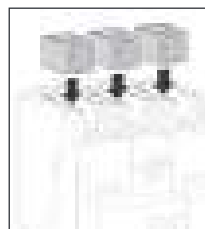

cable clamp for
aluminum
conductors

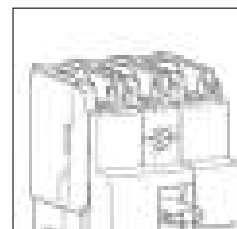

front connections

1

Ratings and Specifications

Molded Case Circuit Breakers

z Fixed thermal and fixed magnetic MCCBs	1-2
x Adjustable thermal and adjustable magnetic MCCBs	1-3
c Switch-disconnectors	1-4

1

Ratings and Specifications

Molded Case Circuit Breakers

z Fixed thermal and fixed magnetic MCCBs

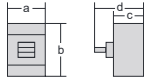
Frame size (A)	100		160		160			160		250			250				
Type	E100-SF		E160-SF		S160-SCF			S160-SF		E250-SF			S250-SF				
Number of poles	2	3	1		2	3	4	3	4	2*	3	4	2*	3	4		
■ Ratings																	
Rated current, A	10	50	16	63	15	75	15	75	125			125					
Calibrated at 40°C	15	60	20	80	20	100	20	100	150			150					
	20	75	25	100	30	125	30	125	175			175					
	30	100	32	125	40	160	40	160	200			200					
	40		40		50		50		225			225					
			50		60		60		250			250					
			(45°C only)														
* center pole omitted																	
Rated insulation voltage (U _i) V	690		690		690			690		690			690				
Rated impulse withstand voltage (U _{imp}) kV	6		8		8			8		8			8				
Utilization Category	A		A		A			A		A			A				
■ Rated breaking capacity, kA																	
IEC 60947-2	AC	690V	-		-		6/3		-			4/4					
I _{cu} /I _{cs} (sym)		500V	7.5/3.8		-		7.5/4		10/7.5		10/7.5			25/13			
		440V	10/5		-		15/7.5		25/13		15/12			30/15			
		415V	10/5		-		25/13		40/20		25/19			40/20			
		380V	16/8		-		25/13		40/20		25/19			40/20			
		240V	25/13		25/13		35/18		50/25		35/27			85/43			
	⊙ DC	250V	7.5/3.8		-		20/10		25/13		15/12			25/13			
		125V	15/7.5		10/5		30/15		40/20		25/19			40/20			
■ Rated short time withstand current, kA																	
■ External dimensions, mm																	
		a	50	75	25	50	75	100	75	100	105	105	140	105	105	140	
		b	130		130		130			130		165			165		
		c	68		68		68			68		68			68		
		d	87		95		95			95		95			95		
Weight (* marked standard type) kg			0.48	0.74	0.3	0.6	0.8	1.0	0.8	1.0	1.5	1.5	1.9	1.5	1.5	1.9	
■ Connections and Mountings																	
Front-connected (FC)	Terminal screws	-															
	With straight extension bars	-															
	With spread extension bars	-															
	Cable clamps	-															
Rear-connected (RC)	Bolt studs	-															
	Flat bar studs	-															
Plug-in (PM)	For switchboards Standard (PMC)	-															
	High-performance (PMB)	-															
	For distribution boards (PMC)	-															
Draw-out type (DR)	-																
TemPlug70 (PG)	-																
TemPlug45B (PG4)	-																
DIN rail mount	-																
Clip-in chassis mount	-																
■ Accessories (optional) Symbol																	
Internally mounted	Auxiliary switch	A X	•														
	Alarm switch	A L	•														
	Shunt trips	S H	•														
	Undervoltage trips	U V	•														
	Motor operator	M C	•														
Externally mounted	External operating handle	H B	•														
	Breaker-mounted	H P	•														
	Door-mounted (variable depth)	H P	•														
	Toggle extension	H A	-														
	Mechanical interlock Slide type	M S	•														
	Toggle holder	H H	•														
	Toggle lock	H L	•														
	Terminal cover For front-connected	C F	•														
	For rear-connected and plug-in	C R	•														
	For cable clamps	C S	-														
	Interpole barrier	B A	•														
	Terminal block for lead	T F	•														
	Door flange	D F	•														
■ Standard specifications																	
Overcurrent trip mechanism	Fixed thermal		Fixed thermal		Fixed thermal			Fixed thermal		Fixed thermal			Fixed thermal				
	Fixed magnetic ⁷		Fixed magnetic		Fixed magnetic			Fixed magnetic		Fixed magnetic			Fixed magnetic				
Trip button (color)	Yes (Red)		Yes (Red)		Yes (Red)			Yes (Red)		Yes (Red)			Yes (Red)				
Handle position indication (ON: Red, OFF: Green)	Yes		Yes		Yes			Yes		Yes			Yes				
Suitability for isolation	Non		Yes		Yes			Yes		Yes			Yes				
CE marking	Non		Yes		Yes			Yes		Yes			Yes				

Notes:
 ' : Standard. This configuration used unless otherwise specified. ◦ : Optional standard. Specify when ordering. • : "yes" or "available". - : "no" or "not available".
 ⊙ : DC rating available on request. ⊕ : Line side interpole barriers are supplied as standard. (Front connection only) ⁷ : Hydraulic-magnetic type for below 10A rating.
 ⊗ : Provided with DIN rail adaptor.

1

Ratings and Specifications

Molded Case Circuit Breakers

x Adjustable thermal and fixed or adjustable magnetic MCCBs

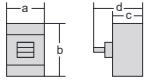
Frame size (A)	160		160		250		250					
Type	S160-SCJ		S160-SJ		E250-SJ		S250-SJ					
Number of poles	3	4	3	4	3	4	3	4				
■ Ratings												
Rated current, A	25		25		100		160					
Calibrated at 45°C	40		40		125		200					
	63		63		160		250					
	80		80		200							
	100		100		250							
	125		125									
	160		160									
Rated insulation voltage (U_i) V												
	690		690		800		800					
Rated impulse withstand voltage (U_{imp}) kV												
	8		8		8		8					
Utilization Category												
	A		A		A		A					
■ Rated breaking capacity, kA												
IEC 60947-2	AC		690V		-		6/3		-		4/4	
I _{cu} /I _{cs} (sym)	525V		7.5/4		10/7.5		7.5/6		10/7.5			
	440V		15/7.5		25/13		15/12		30/15			
	415V		25/13		40/20		25/19		40/20			
	380V		25/13		40/20		25/19		40/20			
	240V		35/18		50/25		35/27		85/43			
	⊙ DC		250V		20/10		25/13		15/12		25/13	
	125V		30/15		40/20		25/19		40/20			
■ Rated short time withstand current, kA												
	-		-		-		-		-		-	
■ External dimensions, mm												
	a		75 100		75 100		105 140		105 140			
	b		130		130		165		165			
	c		68		68		68		68			
	d		95		95		95		95			
												
Weight (* marked standard type) kg												
	0.8 1.0		0.8 1.0		1.5 1.9		1.5 1.9					
■ Connections and Mountings												
Front-connected (FC)												
	Terminal screws		'		'		'		'			
	With straight extension bars		o		o		o		o			
	With spread extension bars		o		o		o		o			
	Cable clamps		o		o		o		o			
Rear-connected (RC)												
	Bolt studs		-		-		-		-			
	Flat bar studs		o		o		o		o			
Plug-in (PM)												
	For switchboards Standard (PMC)		-		-		-		-			
	High-performance (PMB)		-		-		-		-			
	For distribution boards (PMC)		-		-		-		-			
Draw-out type (DR)												
	-		-		-		-		-			
TemPlug⁷⁰ (PG)												
	-		-		-		-		-			
TemPlug^{45B} (PG4)												
	-		-		-		-		-			
DIN rail mount												
	o ⊕		o ⊕		-		-		-			
Clip-in chassis mount												
	-		-		-		-		-			
■ Accessories (optional) Symbol												
Internally mounted	Auxiliary switch		A X		•		•		•		•	
	Alarm switch		A L		•		•		•		•	
	Shunt trips		S H		•		•		•		•	
	Undervoltage trips		U V		•		•		•		•	
	Motor operator		M C		-		-		•		•	
Externally mounted	External operating handle		Breaker-mounted H B		•		•		•		•	
	Door-mounted (variable depth)		H P		•		•		•		•	
	Toggle extension		H A		-		-		-		-	
	Mechanical interlock Slide type		M S		•		•		•		•	
	Toggle holder		H H		•		•		•		•	
	Toggle lock		H L		•		•		•		•	
	Terminal cover		For front-connected C F		•		•		•		•	
	For rear-connected and plug-in		C R		•		•		•		•	
	For cable clamps		C S		•		•		•		•	
	Interpole barrier		B A		• ⊕		• ⊕		• ⊕		• ⊕	
Terminal block for lead		T F		•		•		•		•		
Door flange		D F		•		•		•		•		
■ Standard specifications												
Overcurrent trip mechanism												
	Adjustable thermal		Adjustable thermal		Adjustable thermal		Adjustable thermal					
	Fixed magnetic		Fixed magnetic		Adjustable magnetic		Adjustable magnetic					
	Yes (Red)		Yes (Red)		Yes (Red)		Yes (Red)					
Trip button (color)												
	Yes		Yes		Yes		Yes					
Handle position indication (ON: Red, OFF: Green)												
	Yes		Yes		Yes		Yes					
Suitability for isolation												
	Yes		Yes		Yes		Yes					
CE marking												
	Yes		Yes		Yes		Yes					

Notes:

- ' : Standard. This configuration used unless otherwise specified. o : Optional standard. Specify when ordering. • : "yes" or "available". - : "no" or "not available".
- ⊙ : DC rating available on request. ⊕ : Line side interpole barriers are supplied as standard. (Front connection only)
- ⊕ : Provided with DIN rail adaptor.

1

Ratings and Specifications

Molded Case Circuit Breakers

c Switch-disconnectors

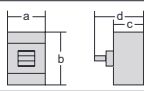
Frame size (A)		160	250						
Type		S160-SN	S250-SN						
Number of poles		3 4	3 4						
■ Ratings									
Rated current, A		160	250						
Rated insulation voltage (U _i) V		690	800						
Rated operational voltage V		AC 250	690 250						
Rated short circuit making capacity, kA peak		2.8	6						
Rated short time withstand current, kA		2 (0.3sec)	3 (0.3sec)						
Rated impulse withstand voltage (U _{imp}) kV		8	8						
■ Performance									
Utilization category		AC 690V	AC-23A						
IEC 60947-3		DC 250V	DC-22A						
Upstream breaker (OCPD) @9			S160-SF						
■ External dimensions, mm									
		a 130	105 140						
		b 68	165						
		c 95	68						
		d 0.7 0.9	95						
Weight (* marked standard type) kg			1.5 1.9						
■ Connections and Mountings									
Front-connected (FC)		Terminal screws	'						
		With straight extension bars	o						
		With spread extension bars	o						
		Cable clamps	o						
Rear-connected (RC)		Bolt studs	-						
		Flat bar studs	o						
Plug-in (PM)		For switchboards Standard (PMC)	-						
		High-performance (PMB)	-						
		For distribution boards (PMC)	-						
Draw-out type (DR)			-						
TemPlug70 (PG)			-						
TemPlug45B (PG4)			-						
DIN rail mount		o ⊕	-						
Clip-in chassis mount			-						
■ Accessories (optional)		Symbol							
Internally mounted	Auxiliary switch	A X	•						
	Alarm switch	A L	•						
	Shunt trips	S H	•						
	Undervoltage trips	U V	•						
Externally mounted	Motor operator	M C	-						
	External operating handle	Breaker-mounted	H B	•					
		Door-mounted (variable depth)	H P	•					
	Toggle extension	H A	-						
	Mechanical interlock	Slide type	M S	•					
		Toggle holder	H H	•					
	Toggle lock	H L	•						
	Terminal cover	For front-connected	C F	•					
		For rear-connected and plug-in	C R	•					
		For cable clamps	C S	•					
	Interpole barrier	B A	• e						
	Terminal block for lead	T F	•						
Door flange	D F	•							
■ Standard specifications									
Trip button (color)		Yes (Red)	Yes (Red)						
Handle position indication (ON: Red, OFF: Green)		Yes	Yes						
Suitability for isolation		Yes	Yes						
CE marking		Yes	Yes						

Notes:

' : Standard. This configuration used unless otherwise specified. o : Optional standard. Specify when ordering. • : "yes" or "available". - : "no" or "not available".

⊕ : Line side interpole barriers are supplied as standard. (Front connection only) ⊕ : Provided with DIN rail adaptor.

@9 Required for overcurrent protection. Rated conditional short-circuit current [I_{cc}] will be the same as Rated short-circuit breaking capacity of upstream breaker.

2

Mounting and Connection

z	Type of connections and mountings	2-2
	List of connecting type.....	2-2
	Connecting parts	2-3
x	Compression terminals	2-4
c	Terminal screw sizes and standard torques	2-6
v	Insulation distance from the line side	2-7
b	Reverse connection	2-8
n	Lists of breaker mounting screws	2-8





2

Mounting and Connection

Molded Case Circuit Breakers

z Type of connections and mountings

List of connecting types

Connecting types (Abbreviation)	Front-connected (FC)			Rear-connected (RC)																		
	For compression terminals / flat bars	With extension bars	With cable clamps	Flat bar studs Stud can be turned 45° or 90°	Bolt studs																	
Outer view Breaker																						
E100-SF	'	—	○	—	○																	
E160-SF	'	○	○	—	—																	
S160-SCF S160-SF	'	○	—	○	—																	
S160-SCJ S160-SJ S160-SN	'	○	○	○	—																	
E250-SF S250-SF E250-SJ S250-SJ S250-SN	'	○	○	○	—																	
Remarks	<ul style="list-style-type: none"> Connect compression terminals or flat bars directly to breaker terminals. 	<ul style="list-style-type: none"> Extension bars are attached to breaker terminals. Connect compression terminals or flat bars to the extension bars. 	<ul style="list-style-type: none"> Cable clamps are attached to breaker terminals. Connect wires directly to cable clamps. 	<ul style="list-style-type: none"> Flat bar studs will be factory installed in the horizontal position unless otherwise specified. For E250, S250, the flat bar studs in the vertical position are available on request. Please select a position code from those shown in the table below: <table border="1"> <thead> <tr> <th rowspan="2">Position code</th> <th colspan="2">Position of flat bar studs</th> </tr> <tr> <th>Line side</th> <th>Load side</th> </tr> </thead> <tbody> <tr> <td>RC-A</td> <td>Vertical</td> <td>Horizontal</td> </tr> <tr> <td>RC-B</td> <td>Horizontal</td> <td>Vertical</td> </tr> <tr> <td>RC-C</td> <td>Vertical</td> <td>Vertical</td> </tr> <tr> <td>RC-D</td> <td>Horizontal</td> <td>Horizontal</td> </tr> </tbody> </table> <ul style="list-style-type: none"> For S160, the studs are horizontal direction only. 	Position code	Position of flat bar studs		Line side	Load side	RC-A	Vertical	Horizontal	RC-B	Horizontal	Vertical	RC-C	Vertical	Vertical	RC-D	Horizontal	Horizontal	
Position code	Position of flat bar studs																					
	Line side	Load side																				
RC-A	Vertical	Horizontal																				
RC-B	Horizontal	Vertical																				
RC-C	Vertical	Vertical																				
RC-D	Horizontal	Horizontal																				

See page 2-6 for dimensions and tightening torques of terminal screws.

Notes:

' : Standard. This configuration used unless otherwise specified.

○ : Optional standard. Specify when ordering.

▲ : Semi-standard.

△ : Custom-built. Contact us for details.

— : "no" or "not available".

q . See page 2-3 for details.

Connecting parts

There are the following connecting/mounting hardware available as options:

1. Extension bars for front connection

Type	Number of poles	Applicable breakers	Min order qty	Constituent parts			Remarks		
				Extension bar	Screw B	Screw C			
T2FB12L2SH	2	S160-SCF, S160-SF, S160-SCJ, S160-SJ, S160-SN	1/2 1	2	2	2			
T2FB12L3SH	3			3	3	3			
T2FB12L4SH	4			4	4	4			
T2FB12L2SB	2			4	4	4			
T2FB12L3SB	3	S160-SCF, S160-SF, S160-SCJ, S160-SJ, S160-SN	1	6	6	6			
T2FB12L4SB	4			8	8	8			
T2FB25L3WH	3			E250-SF, S250-SF, E250-SJ, S250-SJ, S250-SN	1/2 1	3		3	3
T2FB25L4WH	4					4		4	4
T2FB25L3WB	3	E250-SF, S250-SF, E250-SJ, S250-SJ, S250-SN	1	6	6	6			
T2FB25L4WB	4			8	8	8			
T2FB25L2SH	2			2	2	2			
T2FB25L3SH	3	E250-SF, S250-SF, E250-SJ, S250-SJ, S250-SN	1/2 1	3	3	3			
T2FB25L4SH	4			4	4	4			
T2FB25L2SB	2			4	4	4			
T2FB25L3SB	3	E250-SF, S250-SF, E250-SJ, S250-SJ, S250-SN	1	6	6	6			
T2FB25L4SB	4			8	8	8			

i See page 2-6 for screws B and C.

Note q : Two sets, one for the line side and one for the load side, are required per breaker.

2. Frat bar stud for rear connection

Type	Number of poles	Applicable breakers	Min order qty	Constituent parts			Remarks
				Stud bar	Screw D	Screw E	
T2RP12L2S	2	S160-SCF, S160-SF, S160-SCJ, S160-SJ, S160-SN	1	4	4	4	
T2RP12L3S	3			6	6	6	
T2RP12L4S	4			8	8	8	
T2RP25L2S	2	E250-SF, S250-SF, E250-SJ, S250-SJ, S250-SN	1 1	4	4	4	
T2RP25L3S	3			6	6	6	
T2RP25L4S	4			8	8	8	

i See page 2-6 for screws D and E.

Note q : The studs can be rotated to four angular positions: 0 (horizontal), 45, 90 (vertical) and 135 degrees.

2 Mounting and Connection

Molded Case Circuit Breakers

x Compression terminals

Front connected type (without extension bar)

Frame size (A)	Breaker	Nominal wire size (mm ²)										
		2	5.5	8	14	22	38	60	70	80	100	150
100	E100-SF (15-50A)	R2-5 (R2-6)	R5.5-5 (R5.5-6)	R8-5 (R8-6)	R14-5	NTMCB22-5S AMP33114						
	(60-160A)			R8-8	R14-8	R22-8	AMP322870 JST38-S8 NTM38-8S	60-2BA Note 2				
160	S160-SCF, S160-SF, S160-SCJ S160-SJ, S160-SN (15-50A)	R2-5 (R2-6)	R5.5-5 (R5.5-6)	R8-5 (R8-6)	R14-5	NTMCB22-5S AMP33114						
	(60-160A)			R8-8	R14-8	R22-8	AMP322870 JST38-S8 NTM38-8S	60-2BA Note 2	MELEC TM70-8			
250	E250-SF, S250-SF, E250-SJ S250-SJ, S250-SN						R38-8	R60-8		80-3BA Note 2	100-3BA Note 2	CB150-8
										CB80-8	CB100-8	

Front connected type (with extension bar)

Frame size (A)	Breaker	Nominal wire size (mm ²)						
		38	60	80	100	150	200	325
250	E250-SF, S250-SF, E250-SJ, S250-SJ, S250-SN	R38-10	R60-10	R80-10	R100-10	R150-10 CB150-10		

Notes:

q . Commercially made compression terminals can be used (refer to boxes)

R/RD : JIS-compliant

CB : JEM 1399-compliant

AMP : Made by Nippon AMP Co., Ltd.

JST : Made by Japan Solderless Terminal Manufacturing Co., Ltd.

NTK : Made by Nippon Tanshi Co., Ltd.

NTM : Made by Nichifu Terminal Industries Co., Ltd.

MELEC : Made by Shanghai JiaMeng Electrical Equipment Co., Ltd.

w . Compression terminals in box cells are made by us at Terasaki. They are available from us or our authorized agents.

e . Compression terminals enclosed in parentheses are to be used as the lower terminal when two terminals are connected.

Connection (two terminals)

If a shortage of insulating occurs between the mounting plate and a terminal, use a recommended taping or insulator.

When a single terminal is connected

Second terminal when two terminals are connected

Terasaki made compression terminals are used (refer to box)

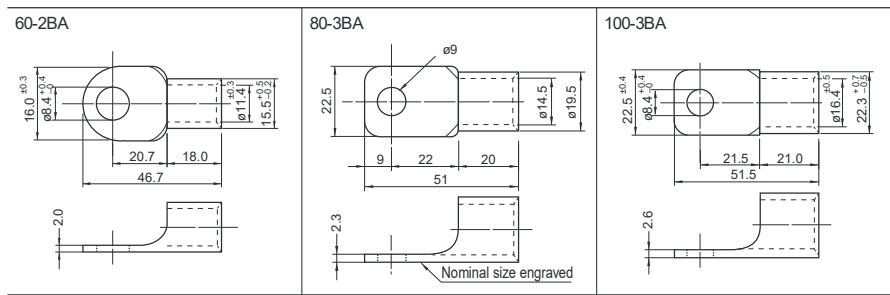

Connection (one electric cable)

If a shortage of insulating occurs, use a recommended taping or insulator.

Make connection so that the screw heads face toward the mounting surface.

Connection (two electric cables)

If a shortage of insulating occurs, use a recommended taping or insulator.

Make connection so that the screw heads face toward the mounting surface.

2

Mounting and Connection

Molded Case Circuit Breakers

c Terminal screw sizes and standard torques

Connecting types		Front connection (FC)			Rear connection (RC) (Flat bar stud)		Rear connection (RC) (Bolt stud)	
Type	Breaker	Compression terminal	Extension bar		Screw size (D) Torque (N·m)	Screw size (E) Torque (N·m)	Screw size (F) Torque (N·m)	Screw size (G) Torque (N·m)
		Screw size (A) Torque (N·m)	Screw size (B) Torque (N·m)	Screw size (C) Torque (N·m)				
100	E100-SF (10~50A)	Pan head M5× 12 Wire clamping screw 2.3~3.4	—	—	—	—	Pan head M4× 14 1.1~1.7	Hex. nut M6 2.7~4.5
	E100-SF (60~100A)	Pan head M8× 14 4.9~6.9	—	—	—	—	Hex head M6 nut 2.7~4.5	Hex. nut M8 6.9~10.8
160	S160-SCF S160-SF S160-SCJ S160-SJ (15~50A)	Wire clamping M5× 14 2.3~3.4	Wire clamping M5× 14 2.3~3.4	Hex head M8× 30 11.8~18.6	Pan head M5× 14 2.3~2.8	Hex head M8× 23 2.7~4.5	—	—
	S160-SCF S160-SF S160-SCJ S160-SJ (60~160A)	Pan head M8× 14 4.9~6.9	Pan head M8× 14 4.9~6.9	Hex head M8× 30 11.8~18.6	Hex socket head M6× 18 7.8~11.8	Hex head M8× 23 11.8~18.6	—	—
	S160-SN	Pan head M8× 14 4.9~6.9	Pan head M8× 14 4.9~6.9	Hex head M8× 30 11.8~18.6	Hex socket head M6× 18 7.8~11.8	Hex head M8× 23 11.8~18.6	—	—
250	E250-SF S250-SF E250-SJ S250-SJ S250-SN	Hex socket head M8× 18 7.8~12.7	Hex socket head M8× 18 7.8~12.7	Hex head M10× 25 22.5~37.2	Hex socket head M6× 18 7.8~11.8	Hex head M8× 25 11.8~18.6	—	—

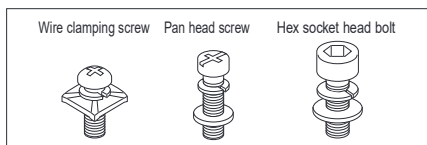

2

Mounting and Connection

Molded Case Circuit Breakers

v Insulation distance from the line side

The insulation distance between the breaker and earthed metal parts and insulators shown in the table on the next page must be maintained to prevent arcing faults occurring due to conductive ionised gas. In addition, completely cover exposed conductors, to their roots at the breaker or to below the height protected by interpole barriers, on the line side of the breaker using insulation tube or tape, in order to provide positive protection against short circuit or ground fault due to metal chipping, surge voltage, dust particles or salt. Be sure to install the interpole barriers supplied with the breaker.

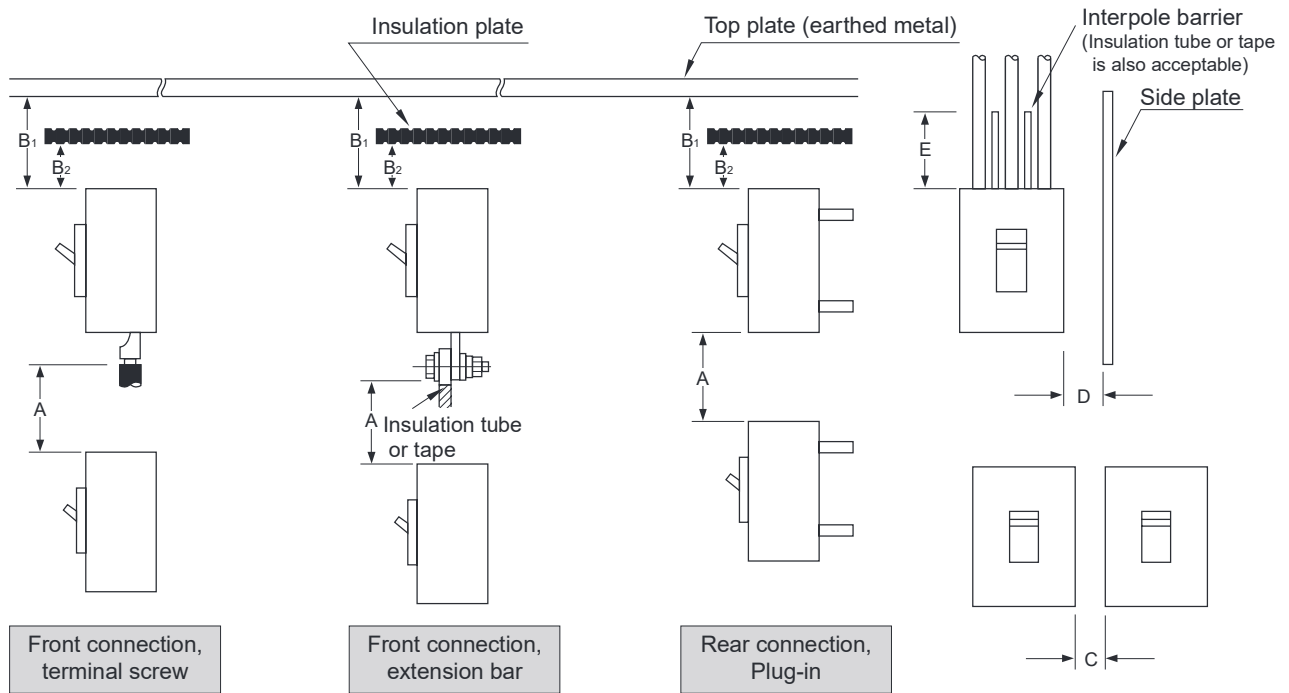
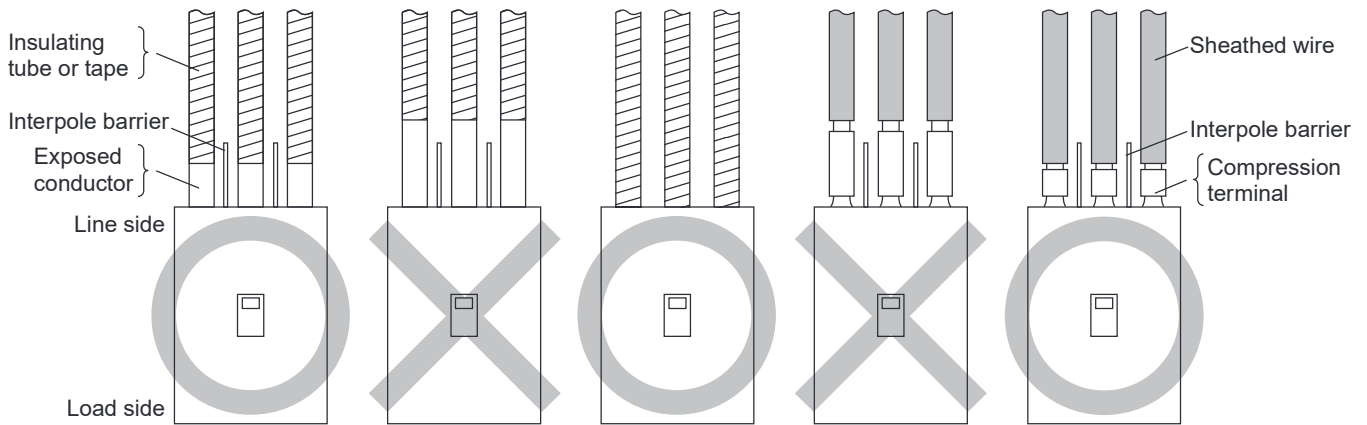

- A . Distance from lower breaker to exposed live part of upper breaker terminal (front connection) or distance from lower breaker to end face of upper breaker (rear connection).
- B1 . Distance from end face of breaker to top plate.
- B2 . Distance from end face of breaker to insulation plate.
- C . Gap between breakers.
- D . Distance from side of breaker to side plate (earthed metal).
- E . Dimension of insulation over exposed conductors.

2 Mounting and Connection

Molded Case Circuit Breakers

v Insulation distance from the line side

Insulation distance, mm (AC 460 V or less) Note q

Molded Case Circuit Breakers

Breaker	A Note ①	B1	B2	*	C	D	E
E100-SF	30	10	10	*	Possible to set close	25	Not less than the length of the bare live part <small>Note 3</small>
E250-SF, E250-SJ	50	40	40	*	Possible to set close	50	Not less than the length of the bare live part <small>Note 3</small>
S160-SCF, S160-SF, S160-SCJ, S160-SJ	50	50	10	*	Possible to set close	25	Not less than the length of the bare live part <small>Note 3</small>
S250-SF, S250-SJ	50	50	40	*	Possible to set close	50	Not less than the length of the bare live part <small>Note 3</small>

- Notes:
- q . Required to allow free and uninterrupted flow of arc gases. Ensure additional clearance or insulation distance if required to perform wiring, barrier installation or electrical work or to meet the need for more insulation distance between bare live parts and grounded metal members in a switchboard or the like.
 - w . The figures are for lower breakers.
 - e . For front connection breakers, insulate all exposed conductors of the line side until the breaker end. If interpole barriers are packed, be sure to use the barriers; more over, insulate all exposed conductors by insulating tape or the like so that the tape overlaps with the barriers.
 - * If using extension bars (optional), ensure the insulation distance specified for the application.

2 Mounting and Connection

Molded Case Circuit Breakers

b Reverse connection

The breakers are available for normal connection by default. Reverse connection is optionally allowed. See the tables below.

Breaker	AC240V	AC415V	AC450V
E100-SF S160-SCF, S160-SF, S160-SCJ, S160-SJ, 160-SN E250-SF, S250-SF, E250-SJ, S250-SJ, S250-SN	⊙	⊙	⊙

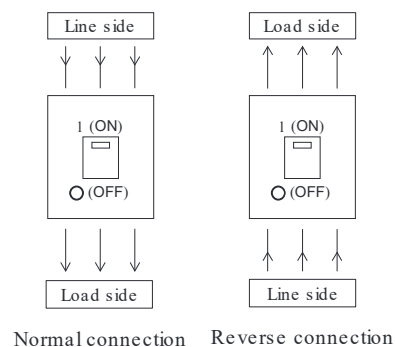

2 Mounting and Connection

Molded Case Circuit Breakers

n Lists of breaker mounting screws

Breaker	Number of poles	Front-connected (FC)		Rear-connected (RC)	
		Screw size	Qty	Screw size	Qty
E100-SF	2,3	Pan head M4× 65	2	Pan head M4× 65	2
S160-SCF, S160-SF, S160-SCJ, S160-SJ, S160-SN	2,3	Pan head M4× 61	2	Pan head M4× 61	2
	4				
E250-SF, S250-SF, E250-SJ, S250-SJ, S250-SN	2,3	Pan head M4× 55	2	Pan head M4× 55	2
	4	Pan head M4× 55	4	Pan head M4× 55	4

3

Accessories

z	Internally mounted accessories	3-2
1.	Connection diagrams and terminal numbers	3-2
2.	Possible combinations	3-2
3.	Ratings and operation data of auxiliary and alarm switches	3-3
4.	Shunt trip device (SHT).....	3-3
5.	Undervoltage trip device (UVT)	3-4
x	Externally mounted accessories	3-6
1.	Motor operators (MC)	3-6
2.	Toggle holder (HH) and toggle lock (HL)	3-9
3.	External operating handles	3-10
(1)	Breaker-mounted (HB) for E100	3-10
(2)	Breaker-mounted (field installable)(HB) for S160, E250, S250	3-12
(3)	Door-mounted (depth adjustable) (HS) standard type	3-16
(4)	Door-mounted (depth adjustable) (HP) ordinal type	3-20
4.	Interpole barriers (BA)	3-25
5.	Terminal covers CF/CR/CS	3-26
(1)	CF for front-connected breakers	3-26
(2)	CR for rear-connected and plug-in breakers	
CS	for front-connected breakers with cable clamps	3-27
6.	Terminal blocks (TF)	3-28
7.	Mechanical interlock	3-30
•	Slide interlock (MS).....	3-30
8.	Door Flange (DF)	3-33

3

Accessories

Molded Case Circuit Breakers

z Internally mounted accessories

1. Connection diagrams and terminal numbers

Accessory	Combination symbol	Connection diagram and terminal No.		Remarks
Shunt trip device (SH)		• With anti-burn switch		Applicable to E100-SF. Shunt trips are fitted with anti-burn switches.
		• Without anti-burn switch		Applicable to other breakers except E100-SF. Shunt trips are continuous rating without anti-burn switches.
Undervoltage trip device (UV)		For AC With UVT controller		Applicable to E100-SF. UVT controller is required for AC UVT. See page 3-5 for the details.
Auxiliary switch (AX)				1pc Aux. SW installed.
				2pcs Aux. SW installed.
				4pcs Aux. SW installed.
Alarm switch (AL)				1pc Alarm. SW installed.
				2pcs Alarm. SW installed.

2. Possible combinations

Molded Case Circuit Breakers

Type	Number of poles q	AX Auxiliary switch	AL Alarm switch	SH Shunt trip	UV Under voltage trip	AX AL	AX SH	AX UV	AL SH	AL UV	AX AL SH	AX AL UV
E100-SF	2											
E100-SF	3											
S160-SCF	2											
S160-SCF S160-SF S160-SCJ S160-SJ S160-SN	3-4											
E250-SF S250-SF E250-SJ S250-SJ S250-SN	3-4											

Notes:
q : The two-pole type breaker obtained by modifying a three-pole breaker by removing the conductive part of its central pole is regarded as the same as the three-pole type.

3. Ratings and operation data of auxiliary and alarm switches

(1) Ratings of AX and AL

• The applicable load of the switch shall be no larger than the rating and no smaller than the minimum load.

Type of breaker	Standard						Minimum load	For microload 1		
	AC (V)			DC (V)				DC (V)		Minimum load
	Voltage (V)	Current (A)		Voltage (V)	Current (A)			Voltage (V)	Resistive load	
Resistive load		Inductive load 2	Resistive load		Inductive load 2					
E100-SF	480	—	—	250	0.2	0.03	DC6V 100mA DC24V 25mA	125	0.1	DC6V 5mA DC24V 1.25mA
	250	3	2	125	0.4	0.05		30	0.1	
	125	3	2	30	3	2				
S160-SCF, S160-SF, S160-SCJ, S160-SJ, S160-SN E250-SF, S250-SF, E250-SJ, S250-SJ, S250-SN	480	—	—	250	—	—	DC15V 100mA	30	0.1	DC5V 1mA
	250	3	2	125	0.4	0.05				
	125	3	2	30	3	2				

Note: 1 This is a custom-made product. When ordering for this product, specify that it is intended for minute load use.

Note: 2 The inductive load means power factor of no smaller than 0.4 and time constant of no larger than 7 ms.

(2) Operation of AX and AL

Switch	Breaker status	[ON]	[OFF]	[TRIP]
Auxiliary switch (AX) status		11/AXc-14/AXa "Closed"	11/AXc-14/AXa "Open"	11/AXc-14/AXa "Open"
		11/AXc-12/AXb "Open"	11/AXc-12/AXb "Closed"	11/AXc-12/AXb "Closed"
Alarm switch (AL) status		91/ALc-94/ALa "Open"	91/ALc-94/ALa "Open"	91/ALc-94/ALa "Closed"
		91/ALc-92/ALb "Closed"	91/ALc-92/ALb "Closed"	91/ALc-92/ALb "Open"

4. Shunt trip device (SH)

Ratings of SHT

Type of breaker	Rated voltage	Peak exciting current, A					
		AC (V)			DC (V)		
E100-SF	100-115	200-480	24	48	100-115	200-230	
		3.4	0.83	1.6	0.71	0.4	0.16

Type of breaker	Rated voltage	Peak exciting current, A					
		AC (V)			DC (V)		
S160-SCF, S160-SF, S160-SCJ, S160-SJ, S160-SN E250-SF, S250-SF, E250-SJ, S250-SJ, S250-SN	100-120	200-240	380-450	24	48	100-120	200-240
		0.014	0.014	0.0065	0.03	0.03	0.011

Notes:

(1) The permissible voltage range is from 70% to 110% of the rated voltage.

Ensure that the voltage does not drop exceeding the permissible voltage range when SHT is actuated.

(2) Breaker contacts usually start opening within 30 ms after the rated voltage is applied to the breaker.

3

Accessories

Molded Case Circuit Breakers

z Internally mounted accessories

5. Undervoltage trip device (UV)

Ratings of UVT with Inst

Type of breaker	Power supply capacity, VA			Exciting current, mA			
	Rated voltage	AC (V)			DC (V)		
		100-120	200-240	380-450	24	100-120	200-240
E100-SF	5 min 2	5 min 2	5 min 2	18.2 1	4.8 1	—	
S160-SCF, S160-SF, S160-SCJ, S160-SJ, S160-SN E250-SF, S250-SF, E250-SJ, S250-SJ, S250-SN	1.4 1	1.5 1	2.3 1	23 1	10 1	3.5 1	

Note: 1 : No UVT controller is required.

2 : Equipped with the UVT controller. See page 3-5 for specifications of the UVT controller.

TemBreak2 UVT are available with 500±300 msec time delays.

UVT controller is installed on the breaker.

Rating of UVT with time delay

Time delays: 500±300 msec.

Applicable breakers	Power supply capacity, VA						Exciting current, mA					
	Rated voltage	AC (V)						DC (V)				
		100-110	115-120	200-220	230-240	380-415	440-450	24	100-110	115-120	200-220	230-240
S160-SCF, S160-SF, S160-SCJ, S160-SJ, S160-SN E250-SF, S250-SF, E250-SJ, S250-SJ, S250-SN	1.1	1.3	2.1	2.5	1.5	1.7	22	7.6	8.3	8.6	9.3	

i Mounting dimensios and terminal arrangement of the UVT controller installed on the breaker

Applicable breakers		A (mm)	B (mm)	C (mm)	D (mm)
160-SCF, S160-SF, S160-SCJ S160-SJ, S160-SN	2P, 3P, 4P	34	55	24	15
E250-SF, S250-SF, E250-SJ S250-SJ, S250-SN	3P, 4P	49.5	55	24	15

• The UVT controller is installed in the right hand side of the breaker

Notes: 1. Tightening torque of terminal screws: 0.9 – 1.2 N·m
2. Applicable lead wire size: 2.0 mm² max

UVT controller for Type E100-SF

E100-SF equipped with the AC UVT need a UVT controller. The UVT controller is installed on the breaker by default. Separate installation of the controller is also available on request. Also a UVT controller (type XCU1D) with a time delay of less than 500 ms is available on request.

i UVT controller connection diagram

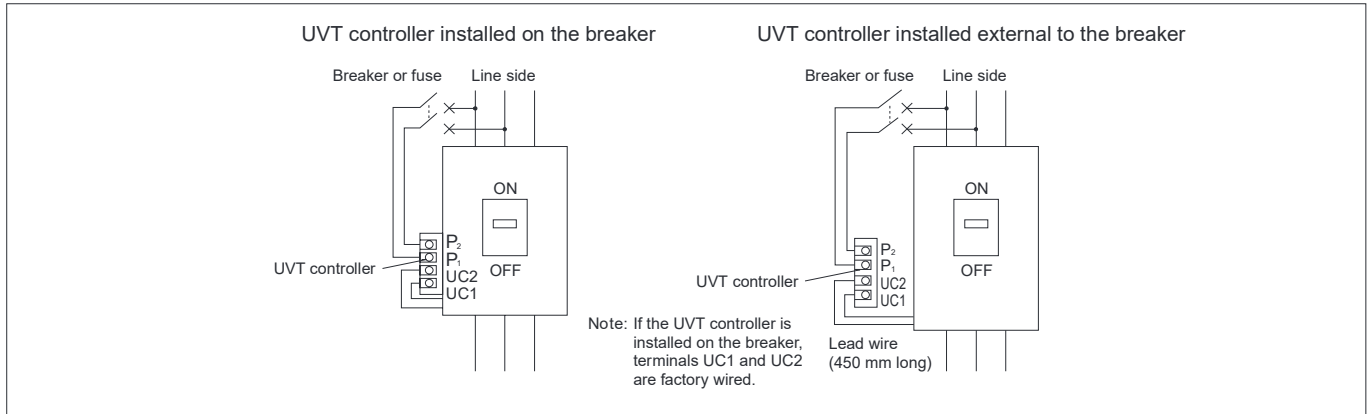

i Mounting dimensions and terminal arrangement of the UVT controller installed on the breaker

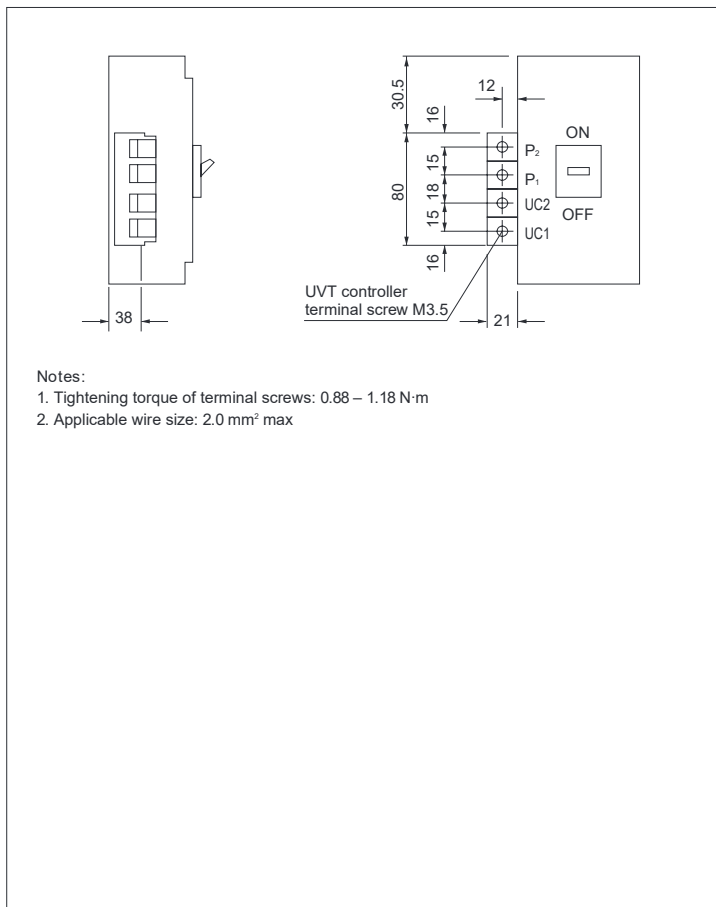

i Outline of the UVT controller installed external to the breaker

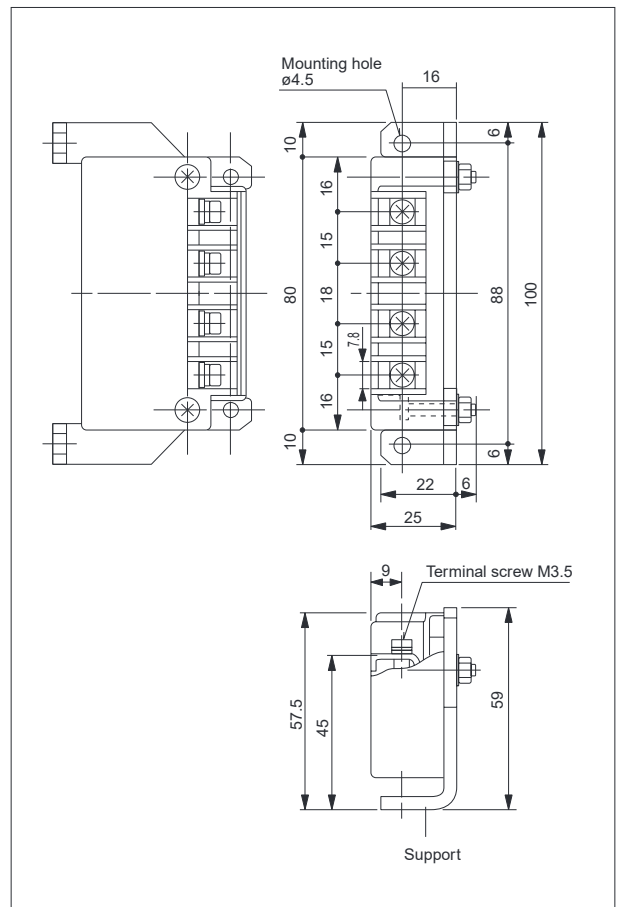

3

Accessories

Molded Case Circuit Breakers

x Externally mounted accessories

1. Motor operators (MC)

Motor driven type

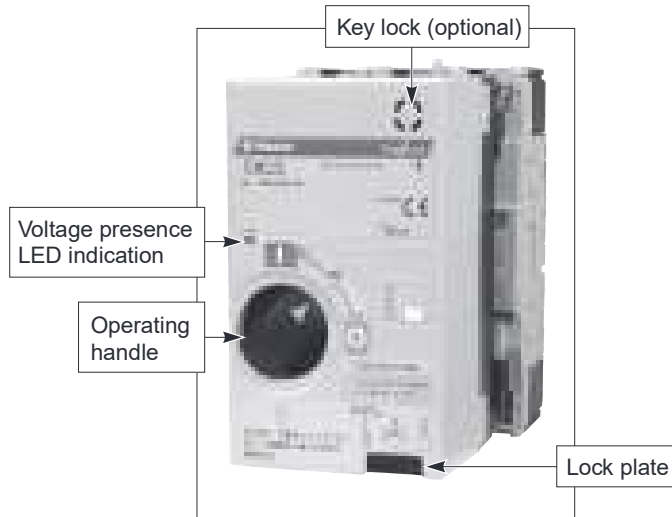

Ratings and Specifications

		T2MC25L
Type of breaker	E250-SF, S250-SF, E250-SJ, S250-SJ, S250-SN	
Rated operational voltage 1	<ul style="list-style-type: none"> • AC100-110V • AC200-220V • AC230-240V • DC24V • DC48V • DC100-110V • DC200-220V 	
Peak steady-state/ starting current, A 2	AC100-110V	4.5/8
	AC200-220V	4/8
	AC230-240V	3.5/7
	DC24V	18/26
	DC48V	12/18
	DC100-110V	2.2/6
	DC200-220V	2.2/5.5
Operation method	Motor driven (direct drive system)	
Operating time, s at rated voltage	ON	0.1
	OFF/RESET	0.1 Ⓞ Ⓞ
Operating switch ratings	100V 0.1A (Open voltage/current: 44 V/4 mA) Ⓞ	
Power supply required	300VA or higher	
Dielectric withstand voltage (for one minute)	AC1500V (AC 1000 V for DC 24/48 V)	
Weight	1.4kg	

Notes:

- Ⓞ : Permissible operating range is 85 to 110%. A power transformer is available as option for AC380V or AC400-460V.
- Ⓞ : The currents shown are the maximum values at the maximum rated operational voltage.
- Ⓞ : The operating time is the value when the rated operational voltage is supplied.
Allow a longer time for the motor operator to complete the operation.
- Ⓞ : The motor operator is of a short time duty. Do not subject it to more than 10 continuous ON-OFF operations. If this occurs, allow the motor operator to cool for at least 15 minutes.
- Ⓞ : When the rated operational voltage is DC24V the open voltage will be DC22V.

Features

★ Installation and removal ease

Simply rotate two knobs allows the motor operator to be installed on or removed from the breaker.

★ High-speed, stable actuation

The operating time as short as up to 0.1 second makes it possible to use the motor operators for synchronized closing of breakers.

★ Silent operation

T2MC25L use a direct drive system, providing operational silence.

★ "Lock-in off" capability

This capability allows the breaker to be padlocked in the OFF state. Up to three padlocks with a 5 to 8 mm hasp diameter can be used. Padlocks are not supplied.

Motorized operation

The motor operator has an input-signal self-hold circuit; closing the ON or OFF switch (see circuit diagrams shown below) momentarily allows activating the motor operator. To reset the tripped breaker to the OFF position, close the OFF (RESET) switch. The voltage presence LED indication is on when the power is supplied to the motor operator.

■ Auto reset feature (optional)

The auto reset feature allows the breaker to be automatically reset approx. 1.5 seconds after the breaker trips open. This option contains auto-reset switches and does not require to use auxiliary or alarm switches installed in the breaker.

Note : that after the thermal OCR trips a thermal-magnetic breaker, the breaker cannot be immediately closed though it can be auto-reset.

Wait for a few minutes after the tripping and provide a close signal to the breaker.

This option resets the tripped breaker automatically, regardless of the cause of the tripping.

Manual operation

Pull the operating handle out. Rotating the handle counterclockwise turns ON the breaker and clockwise turns OFF or resets the breaker.

Operation precautions

1. Ensure that the actual operation voltage ranges from 85% to 110% of the rated one.
2. Use operation switches whose ratings and power capacity is as specified in the “Ratings and Specifications” table on the previous page.
3. Use noise filters if the control power supply of the motor operator is shared by peripheral devices. Otherwise, power supply noise may cause malfunction of the peripheral devices.
4. When the motors are used in conjunction with the mechanical interlock the electrical interlock should be provided between the motors in order to avoid the simultaneous closing. The followings are the available electrical interlock cables.

Interlock cables Order codes	Length	Remarks
T2MM25L05	500mm	for the electrical interlock between T2MC12 and T2MC25/25L.
T2MM25L15	1500mm	
T2MM40L06	600mm	for the electrical interlock between T2MC40 and T2MC80.
T2MM40L21	2100mm	
T2MM40S06	600mm	for the electrical interlock between T2MC40 and T2MC12/25/25L.
T2MM40S21	2100mm	

Control circuit diagrams of motor operators

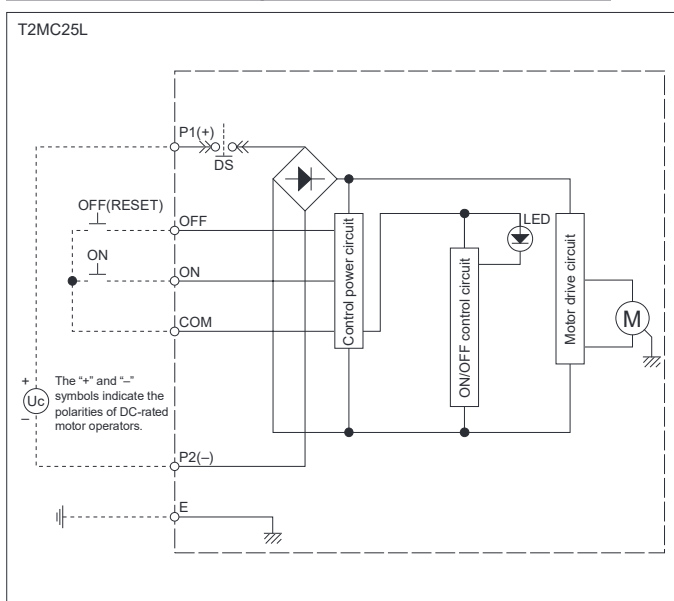

3

Accessories

Molded Case Circuit Breakers

x Externally mounted accessories

1. Motor operators (MC)

Motor driven type

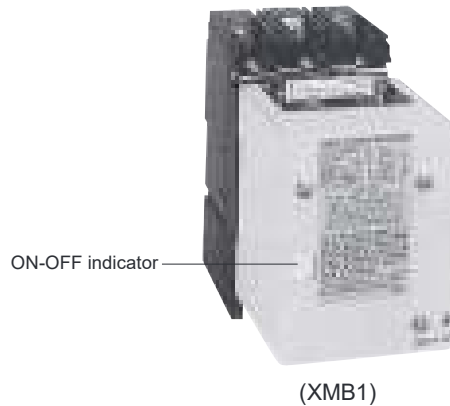

Ratings and Specifications

XMB1									
Series/type of breaker	E100-SF								
Rated operational voltage ①	<ul style="list-style-type: none"> AC100-110V AC200-220V DC100V DC110V 								
Auto reset	Optional ②								
	Non								
Peak steady-state/ starting current, A ③	<table border="1"> <tr> <td>AC100-110V</td> <td>2.0/4.5</td> </tr> <tr> <td>AC200-220V</td> <td>1.0/2.0</td> </tr> <tr> <td>DC100V</td> <td>— ④</td> </tr> <tr> <td>DC110V</td> <td>— ④</td> </tr> </table>	AC100-110V	2.0/4.5	AC200-220V	1.0/2.0	DC100V	— ④	DC110V	— ④
AC100-110V	2.0/4.5								
AC200-220V	1.0/2.0								
DC100V	— ④								
DC110V	— ④								
Operation method	Motor driven								
Operating time, s at rated voltage	<table border="1"> <tr> <td>ON</td> <td>1.2</td> </tr> <tr> <td>OFF/RESET</td> <td>0.85 ⑤ ⑥</td> </tr> </table>	ON	1.2	OFF/RESET	0.85 ⑤ ⑥				
ON	1.2								
OFF/RESET	0.85 ⑤ ⑥								
Operating switch ratings	250V, 5A								
Power supply required	100 VA or higher								
Dielectric withstand voltage (for one minute)	AC1000V								
Weight	1.8								

Notes:

- Ensure that the actual operation voltage is within the following range: 85% to 110% of the AC rated voltage, or 75% to 110% of the DC rated voltage. In case the rated operation voltage is AC 380 V or AC 400 to 460 V, optional power supply transformers are available on request.
- Auto reset require to use auxiliary switch (1b) installed in the breaker. If the number of auxiliary switches is insufficient, actuate an external relay via an auxiliary switch (1a) and use the relay contact (1b) for auto reset.
- The currents shown are the maximum values at the maximum rated operational voltage.
- The operating time assume the motor operator is supplied with the rated operation voltage. Longer operating time will be required under actual operating conditions.
- The motor operator is short-time rated. The number of continuous switching (ON-OFF) cycles must not exceed 10. After any 10 continuous switching cycles, provide a pause of at least 15 minutes to the motor operator for cooling.
- Can be custom-made on request. The outline dimensions of the motor operator will be larger. An auto-reset switch cannot be used. Contact us for details.

Control circuit diagrams of motor operators

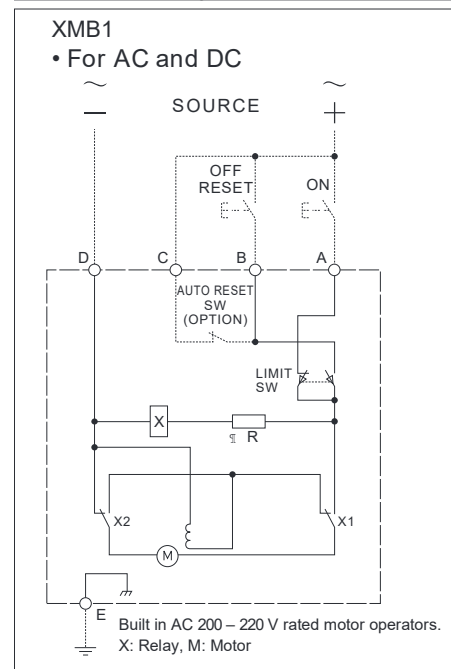

Motorized Operation

■ Breaker ON

Operating the ON switch energises the motor which turns ON the breaker. When the breaker is energised the limit switch operates to de-energise the motor.

Note: This is not a self-holding type. Gives a signal exceeding the operating time.

■ Breaker OFF

Operating the OFF/RESET switch energises the motor which turns OFF the breaker. When the breaker is energised the limit switch operates to de-energise the motor.

Note: This is not a self holding type. Gives a signal exceeding the operating time.

■ Breaker RESET

Operate the OFF/RESET switch to reset the tripped breaker. When the breaker is reset (OFF) the limit switch operates to de-energise the motor.

Note: This is not a self holding type. Gives a signal exceeding the operating time.

Automatic Reset (Optional)

The automatic reset feature can be incorporated by adding the breaker's auxiliary switch contact (b-contact) in parallel with the OFF/RESET control switch.

Note: When the cause of the trip has not been removed the ON-TRIP-RESET-ON operation is repeated. Therefore, do not use the ON operation switch which is normally closed.

Manual Operation

To operate the mechanical test facility of the motor operator pump the manual lever left and right approximately 20 times.

Note: This facility must not be used for ON load operations.

Lock in OFF position

The breaker can be padlocked in the OFF position. (padlock not supplied).

CAUTIONARY NOTES

If the motor operator is turned ON with the breaker OFF and the UVT de-energised, apply the power and complete one ON-OFF operation. (The breaker cannot be turned ON). Then complete one ON operation again (The breaker can be turned ON)

When the breaker is ON and is then tripped, the ON/OFF indicator on the motor operator will be indicating ON until the breaker is reset.

Note: The breaker's condition may differ.

Note: Allow several minutes to cool when a thermal-magnetic breaker is tripped by a thermal overload trip, then reset the breaker.

2. Toggle holder (HH) and toggle lock (HL)

Toggle holder (HH)

Simply fitting the toggle holder onto the breaker toggle disables breaker operation without using padlocks.

Toggle lock (HL)

The toggle lock is a tool that locks the breaker on or off. When an overcurrent occurs, the breaker will trip even if the breaker toggle is locked in the ON position.
(Use commercially available padlocks).

Toggle holders/toggle locks

Type of breaker	Toggle holder		Figure	Toggle lock		Figure
	Order codes	Marking codes		Order codes	Marking codes	
E100-SF	TKB-1DH	—	1	1	—	1
E160-SF, S160-SOF, S160-SF, S160-SCJ, S160-SJ, S160-SN E250-SF, S250-SOF, S250-SF, S250-SCJ, S250-SJ, S250-SN	T2HH25L	T2HH25L	2	T2HL25L	T2HL25L	3

Notes: 1 . A hole must be drilled in the breaker toggle. Please state "with toggle lock (HL)" when ordering.

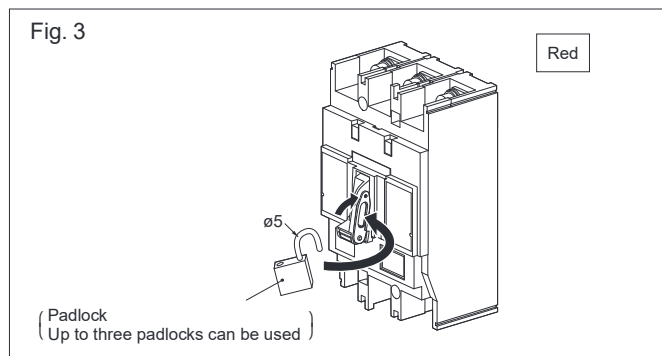
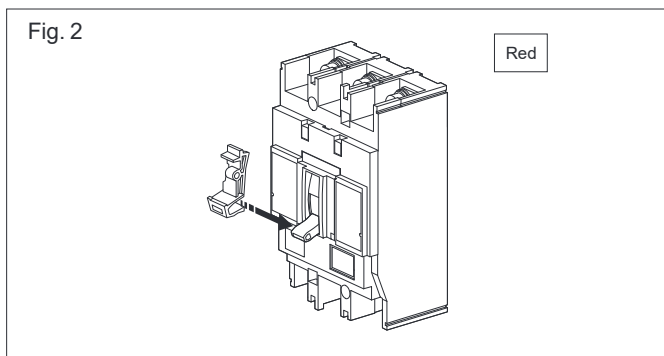
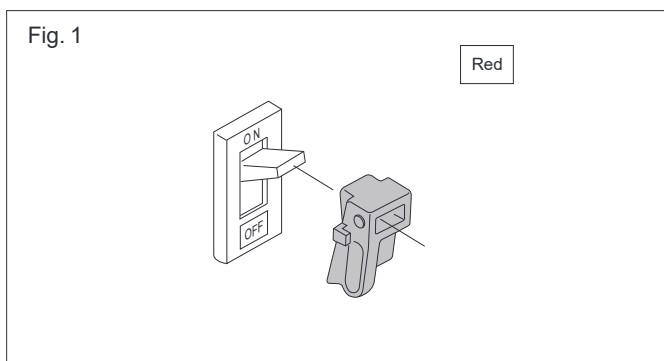

3

Accessories

Molded Case Circuit Breakers

x Externally mounted accessories

3. External operating handles

3-1. Breaker-mounted (HB) for E100

The external operating handle is a tool that allows the breaker installed in a switchboard to be operated from outside. The breaker-mounted type external operating handle is designed to be mounted directly to the breaker body.

■ Outer view

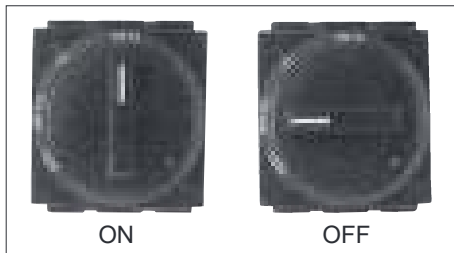

■ Breaker mounting direction

The ON and OFF positions of the handle and the positions of drilled holes in the panel do not need to be changed depending on the breaker mounting direction. The upper power supply type is standard. If a non-standard type is required, state the type when ordering.

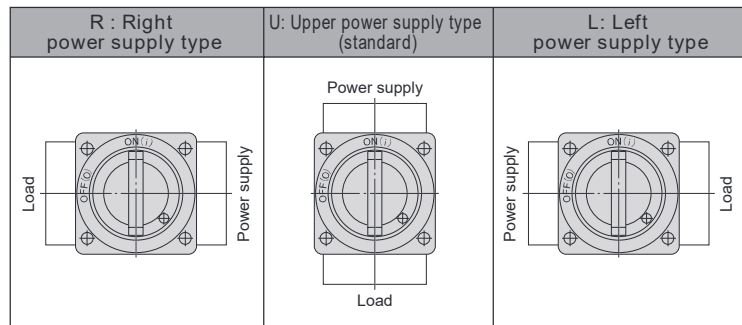

- For a change in mounting direction, see the Operating Instructions packaged with the product.

■ Mounting instructions

The external operating handle has not been mounted on the breakers. For details on how to mount the handle, see the Operating Instructions packaged with the product.

[1] Mounting of external operating handle assembly

Secured to backing plate (TFJ21XH)

- Make sure that the breaker is in the OFF position.
- Put the external operating handle assembly onto the breaker in place so that the breaker toggle is engaged with the slide lever of the assembly. Secure the assembly together with the breaker to the backing plate.

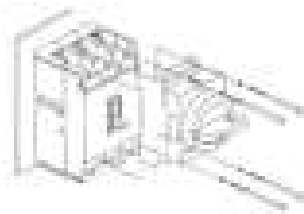
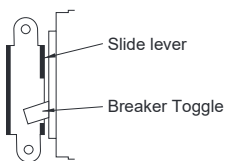

[2] Installation of handle escutcheon and latch plate

- Drill holes in the panel according to the panel cutout dimensions. Sandwich the panel between the handle escutcheon and latch plate and temporarily tighten using the supplied screws.
- Close the panel. Make adjustment so that the gap between the handle assembly and handle escutcheon is even and the assembly is not inclined against the breaker.

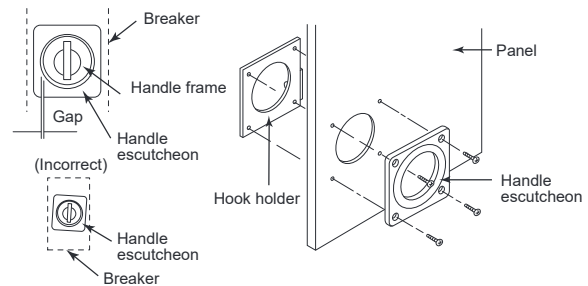

■ Panel lock mechanism

The external operating handle keeps the panel door locked when in the 'ON' position. There are two types, RESET, Open and OFF, Open.

(1) Reset, Open (Standard type)

The handle is turned to the 'RESET/OPEN COVER' position to open the panel door.

(2) OFF, Open

The handle is turned to the OFF position to open the panel door.

• Panel lock release knob

The release knob enables the panel door to be opened with the handle in the 'ON' position. To release: turn the release knob in the direction of anti-clockwise with a flat-bladed screwdriver.

• Safety interlock (Standard)

The safety interlock prevents the breaker from turning ON as long as the panel is open. This interlock can be released using the hook lever.

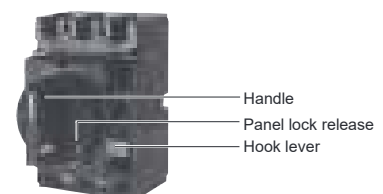

■ Protection degree (IEC 60529)

IP30	standard specification
IP50	optional, with a dust proof packing
IP55	special specification

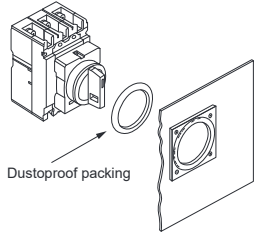

Dustproof packing for IP50 (optional) mm				
Type of handle	Type of dustproof packing	A	B	C
TFJ21XH	Dustproof packing /2	93	73	7

Possible combinations of breaker and external operating handle

Type of external operating handle	Type of breaker
TFJ21XH	E100-SF

■ To be stated when ordering

Order code TFJ21XH U R 3 B

Type of external operating handle	Breaker mounting direction	Panel lock	Protection degree	Colour
TFJ21XH	U: Upper power supply type * R: Right power supply type L: Left power supply type	R : RESET open * F : OFF open	3 : IP30 * 5 : IP50 55: IP55 (special spec.)	B : Black handle (Black base) * R : Red handle (Yellow base)

* standard specification

ASL : Arrangement Standard Line

HL : Handle Frame Centre Line

CL : Handle Centre Line

TFJ21XH

Applicable breaker types	Mounting screw
E100-SF	M4× 75, 2 pcs

i Outline dimensions

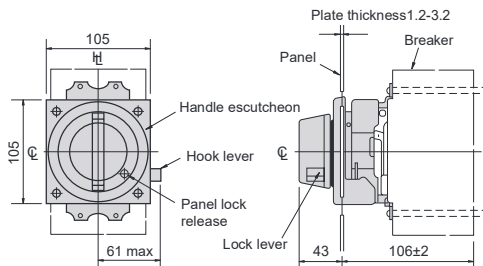

i Panel cutout dimensions

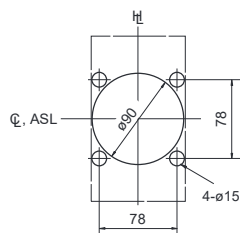

i Relative positions of the hinge and handle as seen from the load side of the breaker

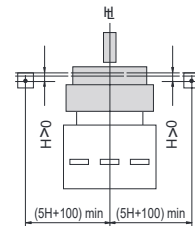

■ Toggle lock mechanism

i Padlock (Standard)

This mechanism allows the breaker to be padlocked in the ON or OFF position.

Padlocks are not supplied.

Up to three padlocks can be installed.



Padlock dimensions (mm)

Type of handle	A	Dia.
TFJ21XH	13 min	ø3.5-6

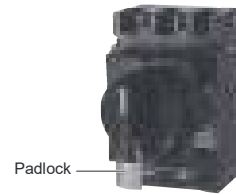

3

Accessories

Molded Case Circuit Breakers

x Externally mounted accessories

3. External operating handles

3-2. Breaker-mounted (field installable) (HB) for S160, E250, S250

The external operating handle is a tool that allows the breaker installed in a switchboard to be operated from outside and complies with IEC 60204-1.

The breaker-mounted type external operating handle is designed to be mounted directly to the breaker body.

■ Outer view

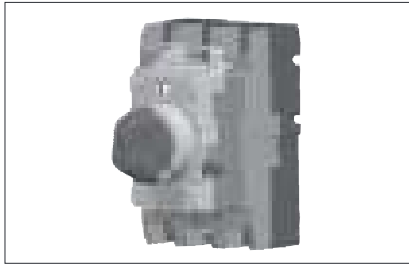

■ Mounting instructions

The external operating handle has not been mounted on the breakers.

For details on how to mount the handle, see the Operating Instructions packaged with the product.

[1] Mounting of external operating handle assembly

- Make sure that the breaker is in the OFF position.
 - Put the external operating handle assembly onto the breaker in place so that the breaker handle is engaged with the handle catch of the assembly.
- Tighten the screw to secure the handle assembly.

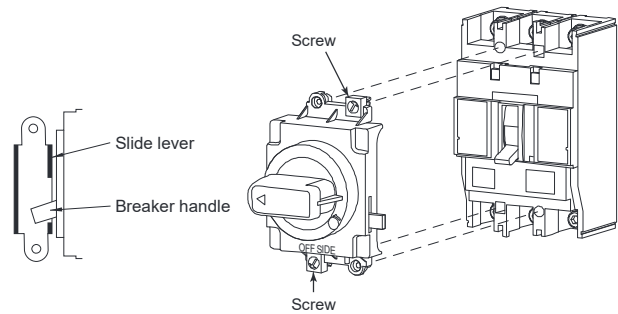

[2] Installation of handle escutcheon and latch plate

- Drill holes in the panel according to the panel cutout dimensions.
- Sandwich the panel between the handle escutcheon and latch plate and temporarily tighten using the supplied screws.
- Close the panel.
- Make adjustment so that the gap between the handle assembly and handle escutcheon is even and the assembly is not inclined against the breaker.

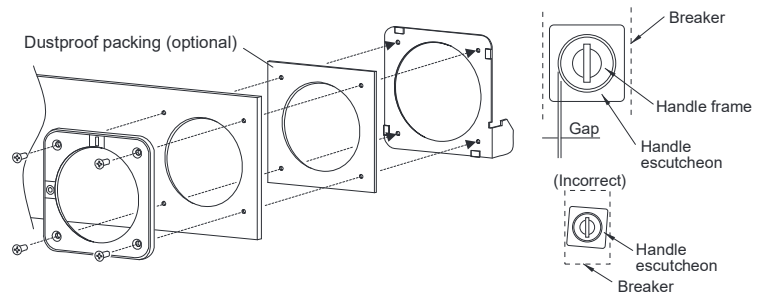

■ Breaker mounting direction

The ON and OFF positions of the handle and the positions of drilled holes in the panel do not need to be changed depending on the breaker mounting direction. The upper power supply type is standard. If a non-standard type is required, state the type when ordering.

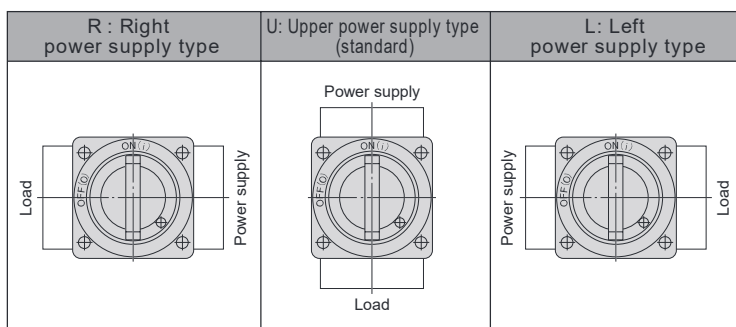

- For a change in mounting direction, see the Operating Instructions packaged with the product.

■ Panel lock mechanism

The external operating handle keeps the panel door locked when in the 'ON' position. There are two types, RESET, Open and OFF, Open.

(1) Reset, Open (Standard type)

The handle is turned to the 'RESET/OPEN COVER' position to open the panel door.

(2) OFF, Open

The handle is turned to the OFF position to open the panel door.

; Panel lock release knob

The release knob enables the panel door to be opened with the handle in the 'ON' position. To release: turn the release knob in the direction of anti-clockwise with a flat-bladed screwdriver.

; Safety interlock (Standard)

The safety interlock prevents the breaker from turning ON as long as the panel is open. This interlock can be released using the hook lever.

■ Toggle lock mechanism

i Padlock (Standard)

This mechanism allows the breaker to be padlocked in the OFF position.

Padlocks are not supplied.

Up to three padlocks can be installed.



Padlock dimensions (mm)

Type of handle	A	Dia.
T2HB	13 min	ø5.5-8

■ Protection degree (IEC 60529)

IP30	standard specification
IP50	optional, with a dust proof packing
IP55	special specification 1

Note 1 : For the depth of switchboard, take account of thickness of the packing. See the Operating Instructions packaged with the product.

Possible combinations of breaker and external operating handle

TemBreak2

Type of breaker	Type of external operating handle
S160-SCF, S160-SF, S160-SCJ, S160-SJ, S160-SN	T2HB16L ①
E250-SF, S250-SF, E250-SJ, S250-SJ, S250-SN	T2HB25L ①

Note 1 : Key lock is not available.

■ To be stated when ordering

Order code T2HB16L U R 3 B N

Type of external operating handle	Breaker mounting direction	Panel lock	Protection degree	Colour	Key lock
T2HB16L T2HB25L	U: Upper power supply type * R: Right power supply type L: Left power supply type	R : RESET open * F : OFF open	3 : IP30 * 5 : IP50 S : IP55 (special spec.)	B : Black handle (Black base) * R : Red handle (Yellow base)	N : without key lock *

* standard specification

3

Accessories

Molded Case Circuit Breakers

x Externally mounted accessories

3. External operating handles

ASL : Arrangement Standard Line

HL : Handle Frame Centre Line

CL : Handle Centre Line

■ Outline dimensions

T2HB16L

Applicable breaker types		
S160-SCF	S160-SF	S160-SCJ
S160-SJ	S160-SN	

i Outline dimensions

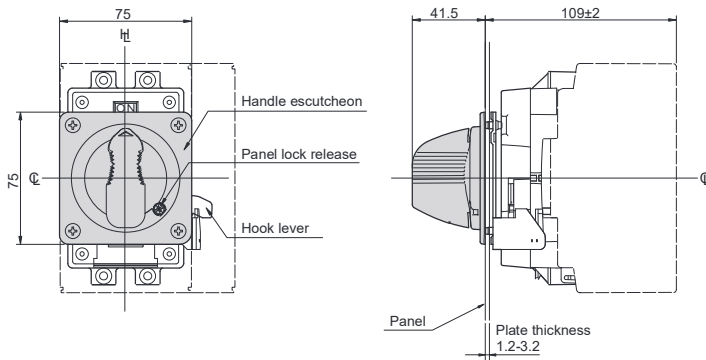

j Panel cutout dimensions

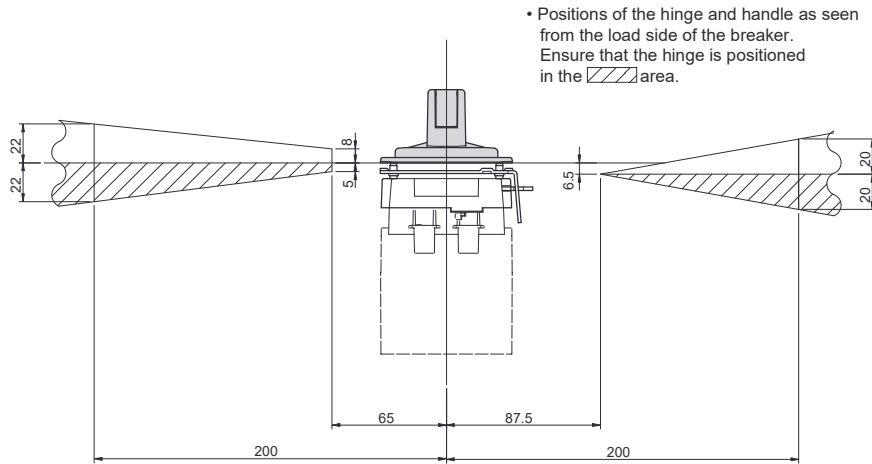
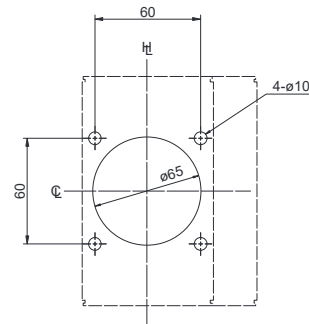

ASL : Arrangement Standard Line
 HL : Handle Frame Centre Line
 CL : Handle Centre Line

T2HB25L

Applicable breaker types		
E250-SF	S250-SF	E250-SJ
S250-SJ	S250-SN	

i Outline dimensions

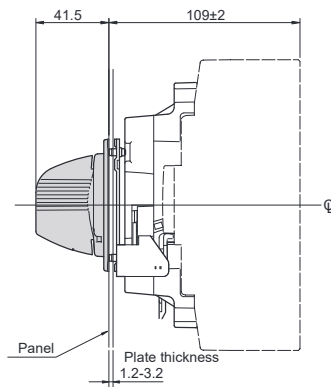
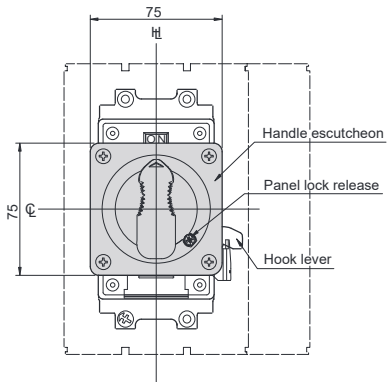

i Panel cutout dimensions

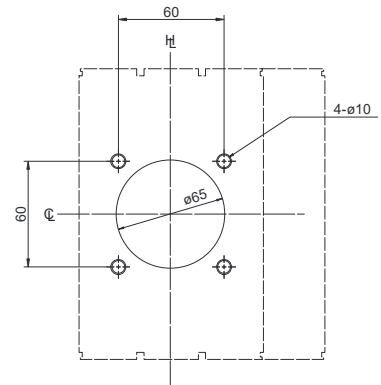

• Positions of the hinge and handle as seen from the load side of the breaker. Ensure that the hinge is positioned in the area.

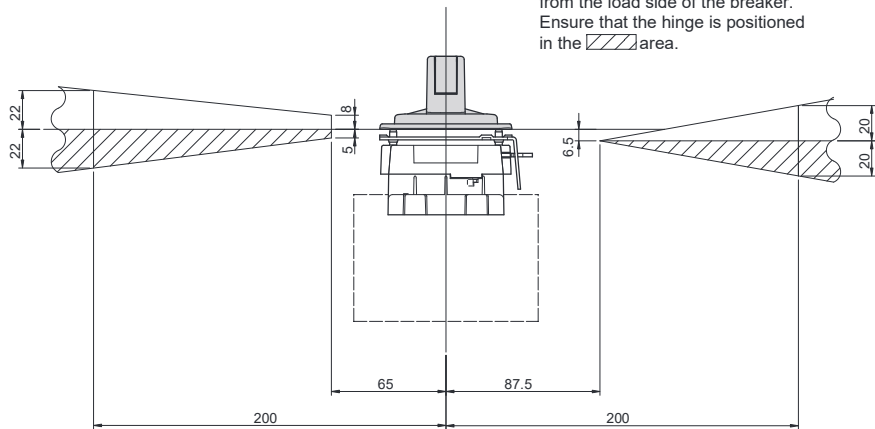

3

Accessories

Molded Case Circuit Breakers

x Externally mounted accessories

3. External operating handles

3-3. Door-mounted (depth adjustable) (HS) standard type

Door-mounted type external operating handles allow breakers installed in control centers or switchboards to be manually operated from outside and complies with IEC 60204-1.

This handle assembly consists of an operation mechanism section which is to be installed in the breaker body, a handle section which is to be installed in a panel and a square shaft which couples both the sections.

Outer view

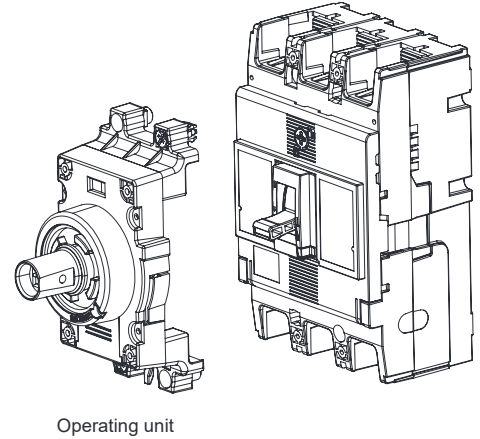
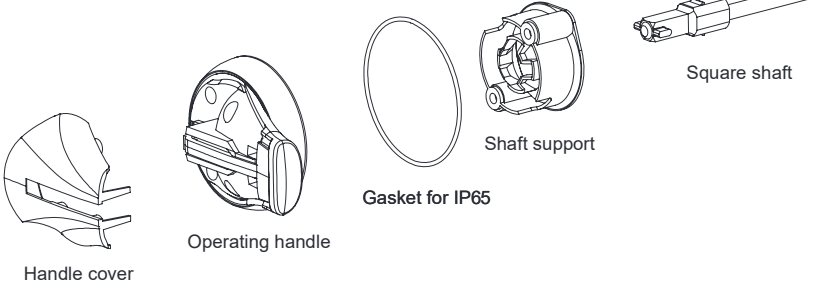
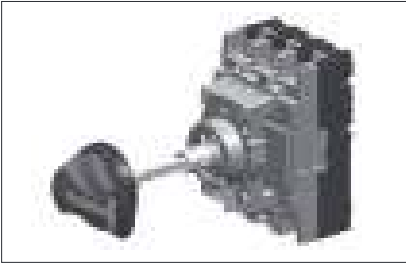

Breaker mounting direction

The ON and OFF positions of the handle and the positions of drilled holes in the panel do not need to be changed depending on the breaker mounting direction.

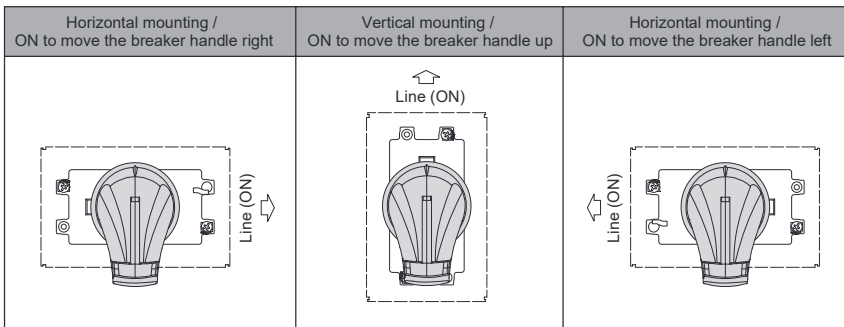

Operation direction of handles

Rotate the operating handle clockwise to turn the breaker on.

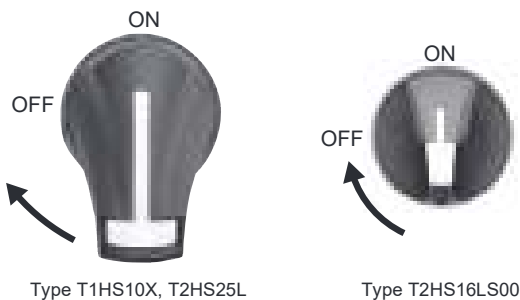

Rotate clockwise to turn the breaker ON

■ Panel lock mechanism

The external operating handle keeps the panel door locked when in the 'ON' position. There is OFF open type only.

OFF open type

The handle is turned to the OFF position to open the panel door.

i Panel lock release button

The release button enables the panel door to be opened with the handle in the 'ON' position. To release: push the release button on the side of the operating handle with a flat-bladed screwdriver.



■ Protection degree (IEC 60529)

IP55	standard specification
IP65	special specification *

*: Special handle unit and gasket are used for IP65.

Possible combinations of breaker and external operating handle

Type of breaker	Type of external operating handle	Shafts order codes
E100-SF	T1HS10X	T2PS083
S160-SCF, S160-SF, S160-SCJ, S160-SJ, S160-SN	T2HS16LS00	T2PS053
E250-SF, S250-SF, E250-SJ, S250-SJ, S250-SN	T2HS25L	T2PS083

■ To be stated when ordering

Order code	T2HS25L	F	5	B	P	N
Type of external operating handle	T1HS10X T2HS16LS00 T2HS25L	Panel lock	Protection degree	Colour	Pad locking lever	Optional
		F : OFF open	5 : IP55 * 6 : IP65 1	B : Gray handle (Black base) * R : Red handle (Yellow base)	P : Plastic M : Metal 2	N : No option S : With shaft support

* standard specification

Note 1 : T1HS10X is not available for IP65.

Note 2 : Metal is not available for T2HS16S00.

■ Toggle lock mechanism

i Padlock (Standard)

This mechanism allows the breaker to be padlocked in the OFF position.

Padlocks are not supplied.

Up to three padlocks can be installed.



Padlock dimensions (mm)

Type of handle	A	Dia.
T2HS16L/25L	13 min	ø5-8

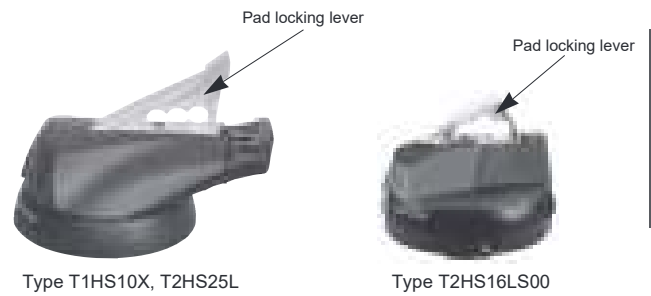

■ Dimensions of square shafts available

There are the following shaft dimensions available. Select an appropriate shaft depending on the mounting position of the breaker. Cut the shaft to an appropriate length if required. Coat the cut end faces of the shaft with an anti-corrosion paint.

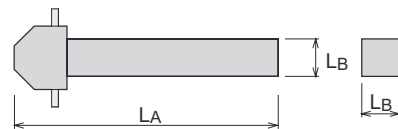

Shafts order codes	LA (mm)	LB (mm)
T2PS083	358	8
T2PS053	352.5	5

■ Shaft support (optional)

The shaft support makes easy to insert to the operating handle when the panel door is being closed.

■ Key fitting facility (optional)

Key fitting facility is available for Castell FS1. Contact us for the details of mounting dimension.

3

Accessories

Molded Case Circuit Breakers

x Externally mounted accessories

3. External operating handles

HL : Handle Frame Centre Line

CL : Handle Centre Line

Outline dimensions

T1HS10X

i Outline dimensions

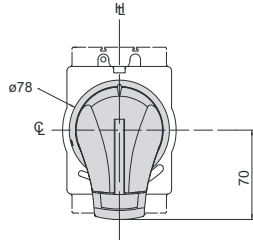

j Panel cutout dimensions

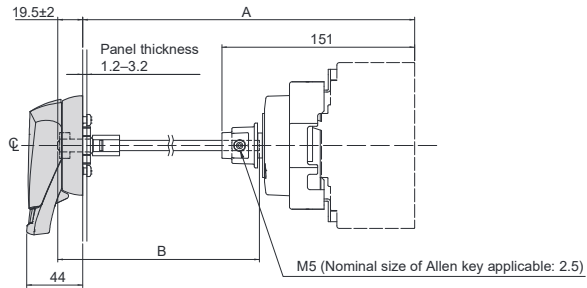
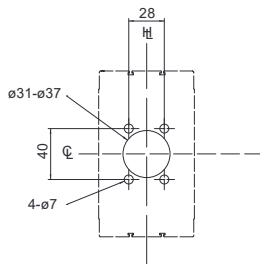

• Positions of the hinge and handle as seen from the load side of the breaker. Ensure that the hinge is positioned in the hatched area.

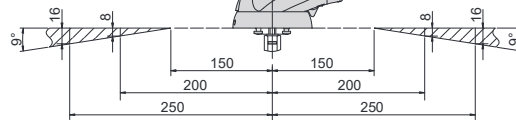

Applicable breaker types	A±2.1	B±0.5
E100-SF	182 min.	80
	460 max.	358

Note q :

"Min (minimum)" means the minimum possible distance from the panel surface to the breaker mounting surface, which can be formed by cutting the square shaft.

"Max (maximum)" means the maximum distance of the same section, which is formed with no cutting of the square shaft.

A: Distance from the panel surface to the breaker mounting surface

B: Length of the square shaft used

■ Outline dimensions

H_L : Handle Frame Centre Line
 C_L : Handle Centre Line

T2HS16LS00

i Outline dimensions

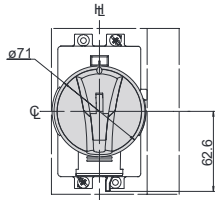

i Panel cutout dimensions

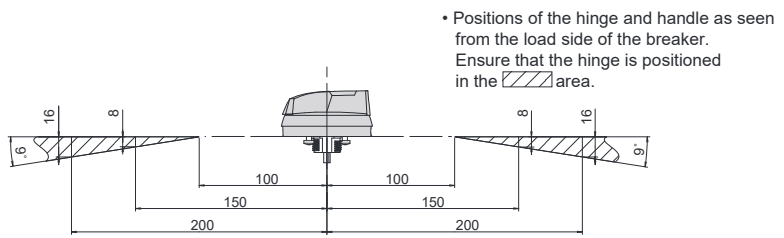
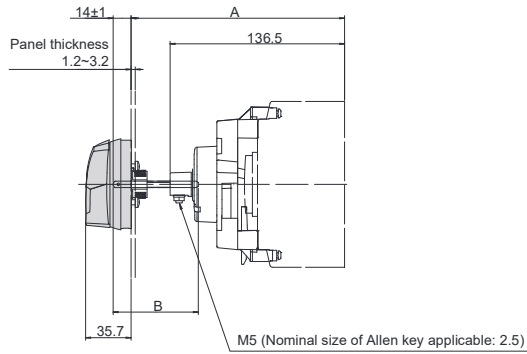
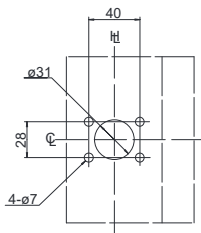

Applicable breaker types			A±1	B±0.5
S160-SCF	S160-SF	S160-SCJ	175 min.	74.5
S160-SJ	S160-SN		453 max.	352.5

Note q :

"Min (minimum)" means the minimum possible distance from the panel surface to the breaker mounting surface, which can be formed by cutting the square shaft.

"Max (maximum)" means the maximum distance of the same section, which is formed with no cutting of the square shaft.

A: Distance from the panel surface to the breaker mounting surface

B: Length of the square shaft used

■ Outline dimensions

T2HS25L

i Outline dimensions

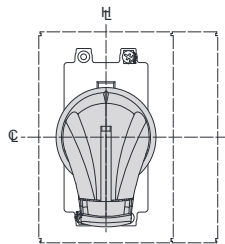

i Panel cutout dimensions

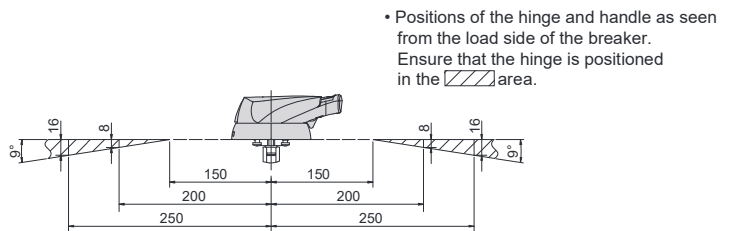
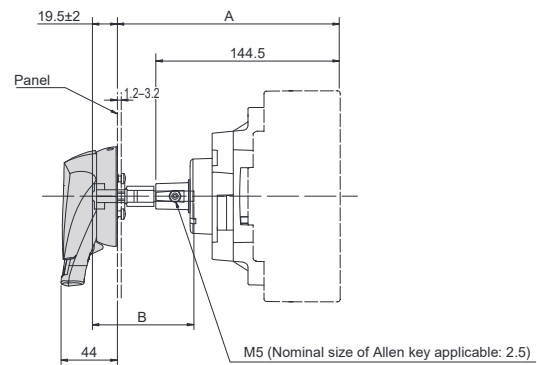
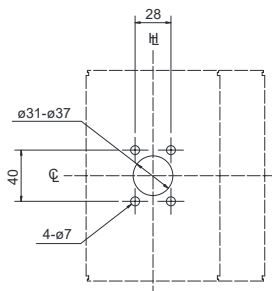

Applicable breaker types			A±2	B±0.5
E250-SF	S250-SF	E250-SJ	175 min.	80
S250-SJ	S250-SN		453 max.	358

Note q :

"Min (minimum)" means the minimum possible distance from the panel surface to the breaker mounting surface, which can be formed by cutting the square shaft.

"Max (maximum)" means the maximum distance of the same section, which is formed with no cutting of the square shaft.

A: Distance from the panel surface to the breaker mounting surface

B: Length of the square shaft used

3

Accessories

Molded Case Circuit Breakers

x Externally mounted accessories

3. External operating handles

3-4. Door-mounted (depth adjustable) (HP) ordinal type

Door-mounted type external operating handles allow breakers installed in control centers or switchboards to be manually operated from outside and complies with IEC 60204-1.

This handle assembly consists of an operation mechanism section which is to be installed in the breaker body, a handle section which is to be installed in a panel and a square shaft which couples both the sections.

■ Outer view

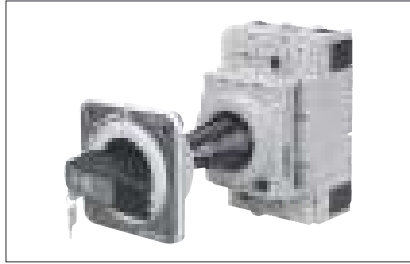

■ Operation direction of handles

Rotate the operating handle clockwise to turn the breaker on.

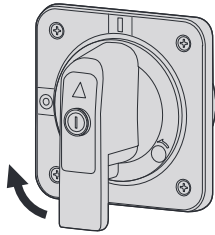

Rotate clockwise
to turn the breaker ON

■ Breaker mounting direction

The ON and OFF positions of the handle and the positions of drilled holes in the panel do not need to be changed depending on the breaker mounting direction.

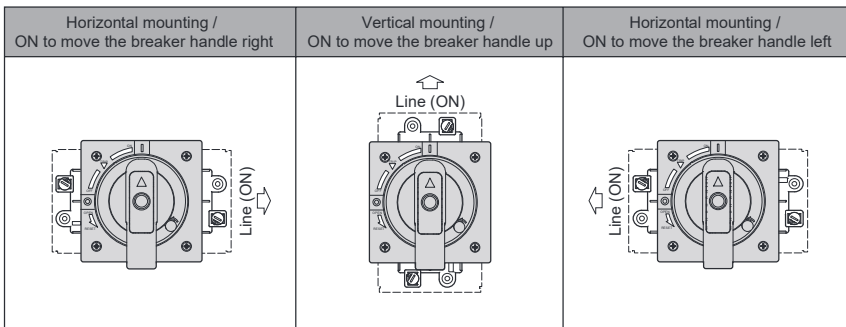

■ Panel lock mechanism

The external operating handle keeps the panel door locked when in the 'ON' position. There are two types, RESET, Open and OFF, Open.

(1) Reset, Open (Standard type)

The handle is turned to the 'RESET/OPEN COVER' position to open the panel door.

(2) OFF, Open

The handle is turned to the OFF position to open the panel door.

i Panel lock release knob

The release knob enables the panel door to be opened with the handle in the 'ON' position. To release: turn the release knob in the direction of anti-clockwise with a flat-bladed screwdriver.

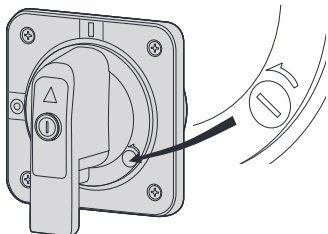

■ Protection degree (IEC 60529)

IP54	standard specification
IP65	special specification

■ To be stated when ordering

Order code T2HP16L R 5 B N

Type of external operating handle	Panel lock	Protection degree	Colour	Key lock
T1HP10X T2HP16L T2HP25L	R : RESET open * F : OFF open	5 : IP54 * 6 : IP65	B : Black handle (Black base) * R : Red handle (Yellow base)	K : with key lock N : without key lock *

* standard specification

Possible combinations of breaker and external operating handle

Type of breaker	Type of external operating handle
E100-SF	T1HP10X
S160-SCF, S160-SF, S160-SCJ, S160-SJ, S160-SN	T2HP16L
E250-SF, S250-SF, E250-SJ, S250-SJ, S250-SN	T2HP25L

■ Toggle lock mechanism

i Padlock (Standard)

This mechanism allows the breaker to be padlocked in the OFF position.

Padlocks are not supplied.

Up to three padlocks can be installed.



Padlock dimensions (mm)

Type of handle	A	Dia.
T2HP	13 min	ø5.5-8

i Key lock (Optional)

Key locking is possible in the OFF position.

■ Dimensions of square shafts available

There are the following shaft dimensions available. Select an appropriate shaft depending on the mounting position of the breaker. Cut the shaft to an appropriate length if required. Coat the cut end faces of the shaft with an anti-corrosion paint.

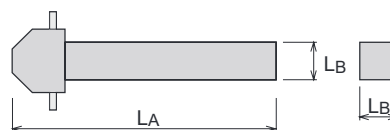

Shafts order codes	LA (mm)	LB (mm)
T2PS251	121	
T2PS252	221	
T2PS253	321	8
T2PS254	421	

3

Accessories

Molded Case Circuit Breakers

x Externally mounted accessories

3. External operating handles

ASL : Arrangement Standard Line

HL : Handle Frame Centre Line

CL : Handle Centre Line

Outline dimensions

T1HP10X

i Outline dimensions

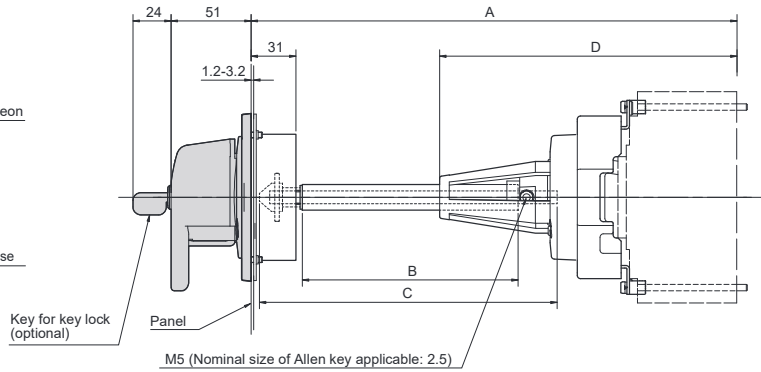
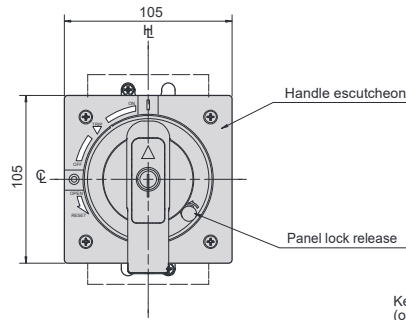

i Panel cutout dimensions

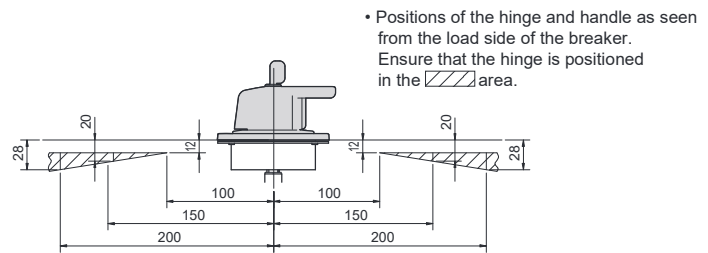
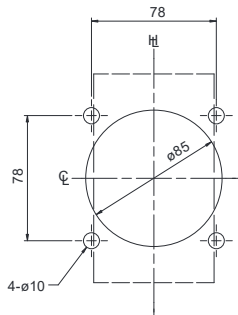

Applicable breaker types	A \ominus	B	C	D	Square shaft applicable	Shaft support
E100-SF	236min.	56	107	194	T2PS251	Yes
	250max.	70	121	194		Yes
	350max.	170	221	194	T2PS252	Yes
	450max.	270	321	194	T2PS253	Yes
	550max.	370	421	194	T2PS254	Yes

Note q :

"Min (minimum)" means the minimum possible distance from the panel surface to the breaker mounting surface, which can be formed by cutting the square shaft.

"Max (maximum)" means the maximum distance of the same section, which is formed with no cutting of the square shaft.

A: Distance from the panel surface to the breaker mounting surface

B: Length of the tube used to cover the square shaft

C: Length of the square shaft used

D: Distance from the tip of the shaft support to the breaker mounting surface

ASL : Arrangement Standard Line
 H : Handle Frame Centre Line
 C : Handle Centre Line

■ Outline dimensions

T2HP16L

i Outline dimensions

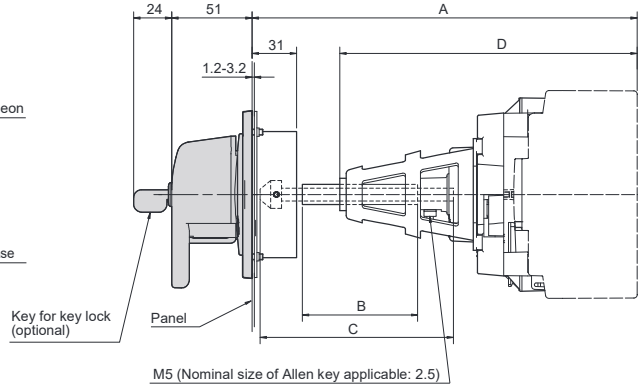
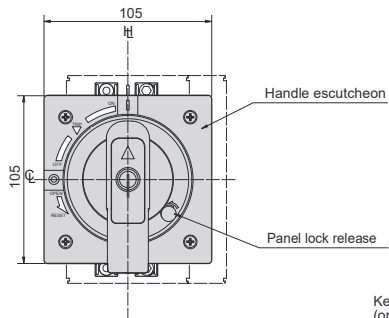

i Panel cutout dimensions

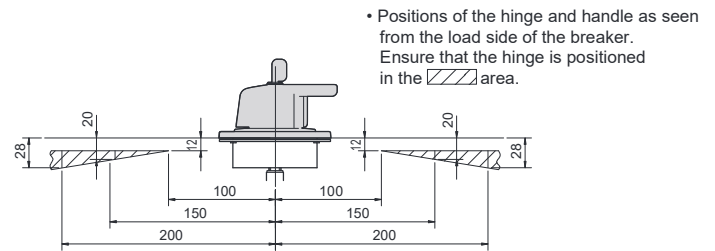
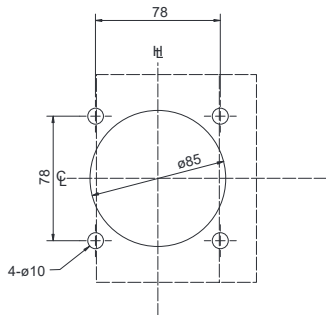

Applicable breaker types			A \ominus	B	C	D	Square shaft applicable	Shaft support
S160-SCF	S160-SF	S160-SCJ	229 min.	56	107	186	T2PS251	Yes
S160-SJ	S160-SN		243 max.	70	121	186		Yes
			343 max.	170	221	186	T2PS252	Yes
			443 max.	270	321	186	T2PS253	Yes
			543 max.	370	421	186	T2PS254	

Note q :

"Min (minimum)" means the minimum possible distance from the panel surface to the breaker mounting surface, which can be formed by cutting the square shaft.
 "Max (maximum)" means the maximum distance of the same section, which is formed with no cutting of the square shaft.

- A: Distance from the panel surface to the breaker mounting surface
- B: Length of the tube used to cover the square shaft
- C: Length of the square shaft used
- D: Distance from the tip of the shaft support to the breaker mounting surface

3

Accessories

Molded Case Circuit Breakers

x Externally mounted accessories

3. External operating handles

ASL : Arrangement Standard Line

HL : Handle Frame Centre Line

CL : Handle Centre Line

Outline dimensions

T2HP25L

i Outline dimensions

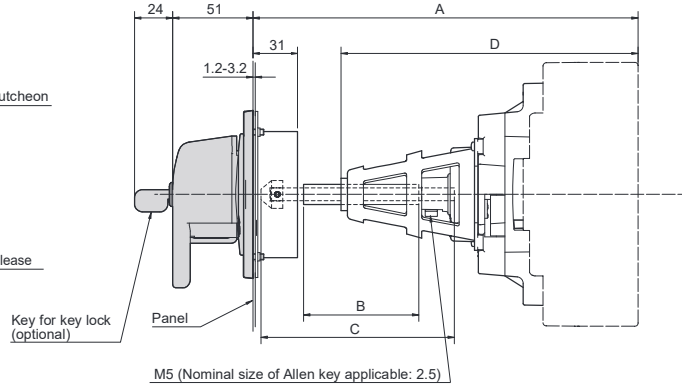
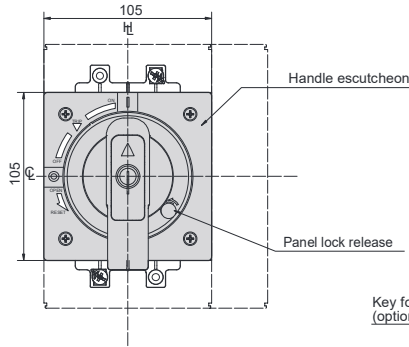

j Panel cutout dimensions

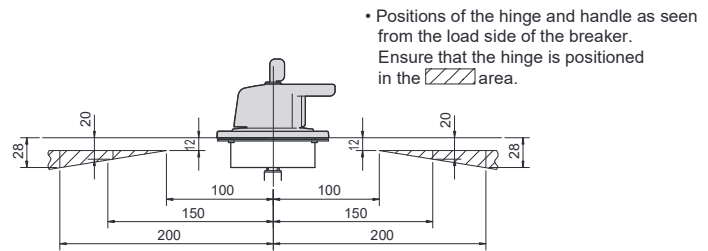
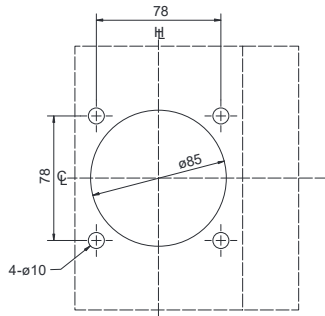

Applicable breaker types			A \ominus	B	C	D	Square shaft applicable	Shaft support
E250-SF	S250-SF	E250-SJ	229 min.	56	107	186	T2PS251	Yes
S250-SJ	S250-SN		243 max.	70	121	186		Yes
			343 max.	170	221	186	T2PS252	Yes
			443 max.	270	321	186	T2PS253	
			543 max.	370	421	186	T2PS254	Yes

Note q :

"Min (minimum)" means the minimum possible distance from the panel surface to the breaker mounting surface, which can be formed by cutting the square shaft.

"Max (maximum)" means the maximum distance of the same section, which is formed with no cutting of the square shaft.

A: Distance from the panel surface to the breaker mounting surface

B: Length of the tube used to cover the square shaft

C: Length of the square shaft used

D: Distance from the tip of the shaft support to the breaker mounting surface

4. Interpole barriers (BA)

Interpole barriers serve to enhance electrical insulation between poles and prevent short-circuit due to electrically conductive foreign matter. Combined use of interpole barriers and terminal covers (standard type) is not possible.

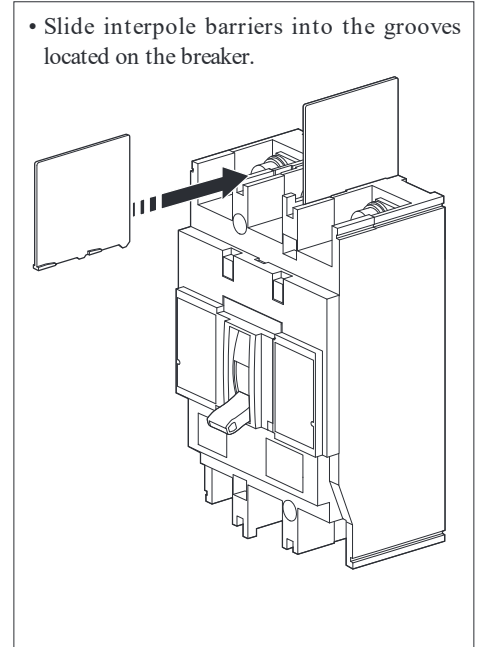
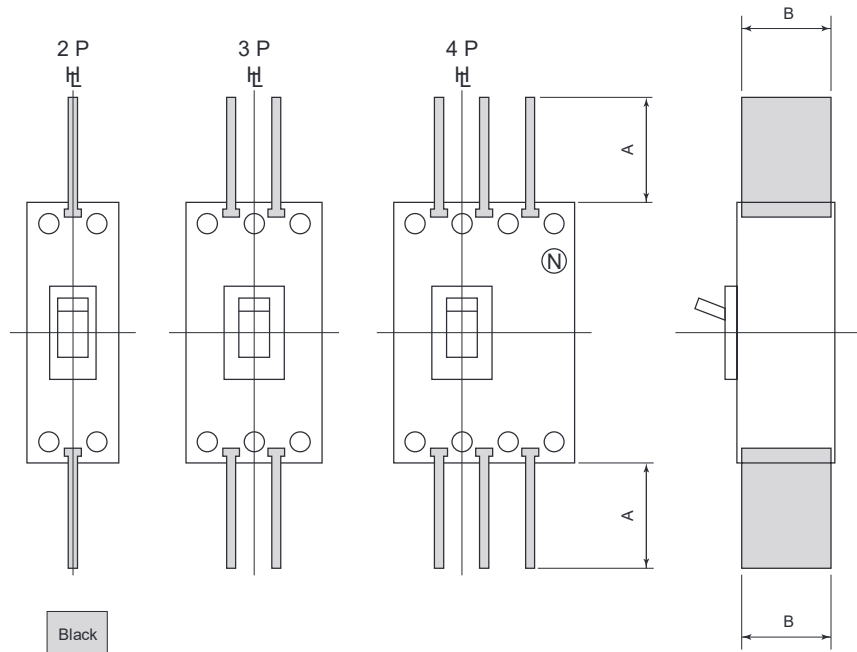

- To be stated when ordering
Please state the type when ordering. One set contains two barriers.
Caution: Be sure to use the interpole barriers supplied with the breaker in order to prevent accidents.

Types and dimensions of interpole barriers, units in mm

Types of breakers	Interpole barrier		A	B
	Type	Code		
E100-SF	TQQ-2CC	—	36	50
S160-SCF, S160-SF, S160-SCJ	T2BA16L3SH	—	50	55
S160-SJ, S160-SN				
E250-SF, S250-SF, E250-SJ	T2BA25L3SH	T2BA25LS	101	53
S250-SJ, S250-SN				

Note q : Line side interpole barriers are supplied as standard for front connected breakers.

3

Accessories

Molded Case Circuit Breakers

x Externally mounted accessories

5. Terminal covers CF/CR/CS

Terminal covers prevent live parts of the breaker from being exposed to the external environment. There are three types of terminal covers available: CF for front-connected breakers, CR for rear-connected and plug-in breakers, and CS for front-connected breakers with cable clamps. Select appropriate terminal covers depending on the type and application of the breaker.

(1) CF for front-connected breakers

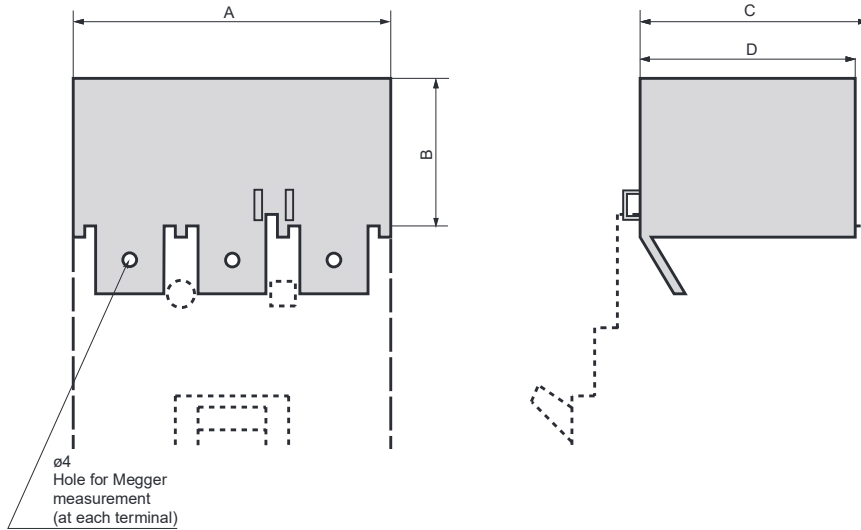

Plug-in mounted version

This version can be mounted simply by being plugged in the breaker body.

- To be stated when ordering
 - Please state the order codes in the table below. One set includes one terminal cover for the ON side and one for the OFF side.

Types and dimensions of terminal covers, units in mm

CF for front-connected breakers

Types of breakers	Terminal cover				A		B		C		D		Colour of cover G: Gray C: Clear	Mounting version	
	Size	Note	Order codes 1	Marking codes	2 poles	3 poles	4 poles	2/3 poles	4 poles	2/3 poles	4 poles	2/3 poles		4 poles	Plug-in mounted
E100-SF	Large		XPR1 * G XPR1 * C	—	49	74	—	30	—	63	—	54	—	○	—
	Small		TPT1 * G TPT1 * C	—	49	74	—	2	—	63	—	54	—		
S160-SF, S160-SCJ S160-SJ, S160-SN	Large		T2CF16L * SLNG T2CF16L * SLNC	—	—	75	100	50	50	61	61	60.3	60.3	○	—
	Small		T2CF16L * SSNG T2CF16L * SSNC	—	—	75	100	25	25	61	61	60.3	60.3		
S160-SCF	Large		T2CF16L * SLNG T2CF16L * SLNC	—	50	75	100	50	50	61	61	60.3	60.3	○	—
	Small		T2CF16L * SSNG T2CF16L * SSNC	—	50	75	100	25	25	61	61	60.3	60.3		
E250-SF, S250-SF E250-SJ, S250-SJ, S250-SN	Small		T2CF25L * SSNG T2CF25L * SSNC	T2CF25L * SS	105	105	140	29	29	59	59	57.5	57.5	○	—
			T2CF25L * SWNG T2CF25L * SWNC	T2CF25L * SW	147.5	147.5	196	55	55	59	59	57.5	57.5		
	Large	⊙	T2CF25L * SLNG T2CF25L * SLNC	T2CF25L * SL	105	105	140	55	55	59	59	57.5	57.5	○	—

- Notes:
- ⊙ . The asterisk indicates the number of poles. Please state the number of poles at the asterisk position when ordering.
 - ⊙ . Applicable to 3-pole breakers with spread extension bars.

(2) CR for rear-connected
CS for front-connected breakers with cable clamps

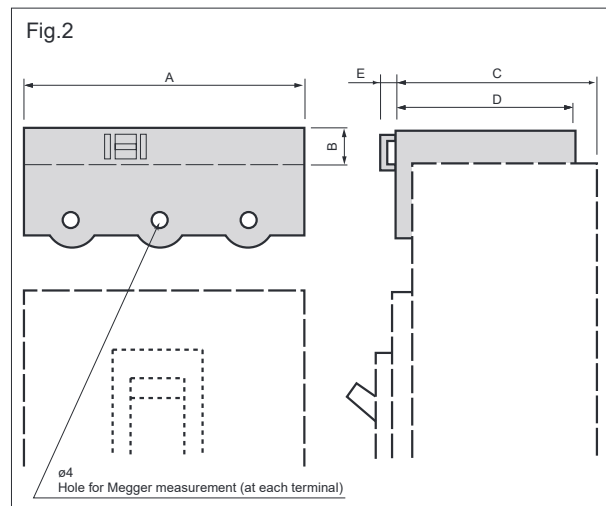
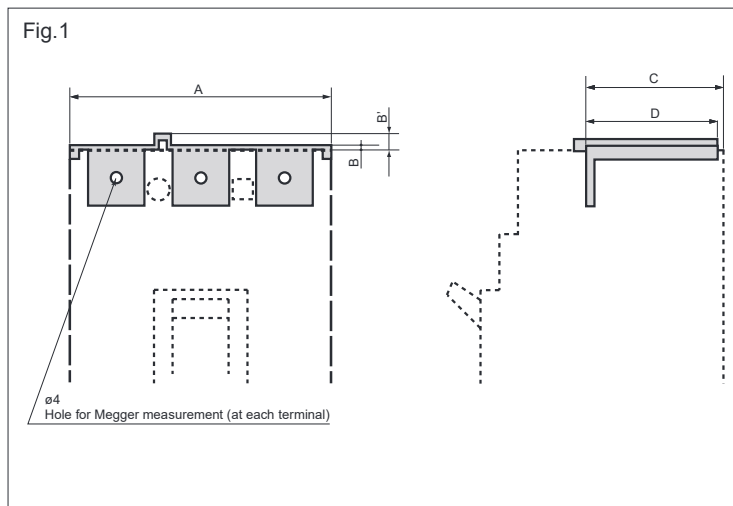

- To be stated when ordering
 - Please state "with CR" if ordering along with the breaker.
 - Please state the order codes in the table below if ordering separately from the breaker.
- One set includes one terminal cover for the ON side and one for the OFF side.

Plug-in mounted version

This version can be mounted simply by being plugged in the breaker body.

Types and dimensions of terminal covers, units in mm

CR for rear-connected

Types of breakers	Terminal cover		A		B		B'	C		D		Colour of cover G: Gray	Figure	
	Order codes 1	Marking codes	2 poles	3 poles	4 poles	2/3 poles		4 poles	2/3 poles	4 poles				
S160-SF, S160-SCJ, S160-SJ S160-SN	T2CR12L * SG	—	—	75	100	5.5	5	—	61	61	60.3	60.3	G	1
S160-SCF	T2CR12L * SG	—	50	75	100	5.5	5	—	61	61	60.3	60.3	G	1
E250-SF, S250-SF, E250-SJ S250-SJ, S250-SN	T2CR25L * SG	T2CR25L	105	105	140	2.3	2.3	5.3	58.6	58.6	57.1	57.1	G	1

Types of breakers	Terminal cover		A		B		E (To screw head)	C		D		Colour of cover G: Gray	Figure	
	Order codes 1	Marking codes	2 poles	3 poles	4 poles	2/3 poles		4 poles	2/3 poles	4 poles				
E100-SF	XPS1 * G	—	49	74	—	10	—	2.5	63	—	54	—	G	2

Notes:

- ⊙ . The asterisk indicates the number of poles. Please state the number of poles at the asterisk position when ordering.
- One set includes one terminal cover for the ON side and one for the OFF side.

CS for front-connected breakers with cable clamps

Types of breakers	Terminal cover		A		B	B'	C	D	Colour of cover G: Gray	Figure
	Order codes 1	Marking codes	3 poles	4 poles						
S160-SCJ, S160-SJ, S160-SN	T2CS12L * SG	T2CS12L * S	75	100	5.5	—	61	60.3	G	1
E250-SF, S250-SF, E250-SJ S250-SJ, S250-SN	T2CS25L * SG	T2CS25L * S	105	140	2.3	5.3	58.6	57.1	G	1

Notes:

- ⊙ . The asterisk indicates the number of poles. Please state the number of poles at the asterisk position when ordering.
- One set includes one terminal cover for the ON side and one for the OFF side.

3

Accessories

Molded Case Circuit Breakers

x Externally mounted accessories

6. Terminal blocks (TF)

6 terminals

Vertical leading type with 100A frame

Mounting position/typical terminal arrangement

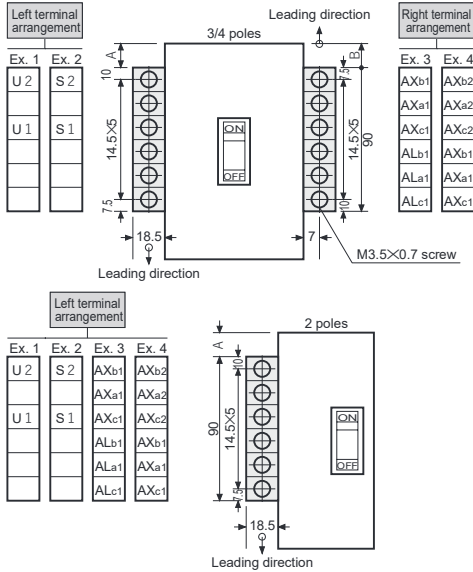

Dimensions, mm

Frame size (A)	Types of breakers	A	B	C	D
100	E100-SF \odot	16.5	16.5	21	36

Notes:

\odot : Terminal block cannot be mounted on the breaker which is equipped with the motor operator.

- 1) Tightening torque of M3.5 terminal screws: 0.9 – 1.2 N·m
- 2) Applicable wire size: 1.25mm² max (Vinyl-coated wire)

6 terminals

Vertical leading type with 160A frame

Mounting position/typical terminal arrangement

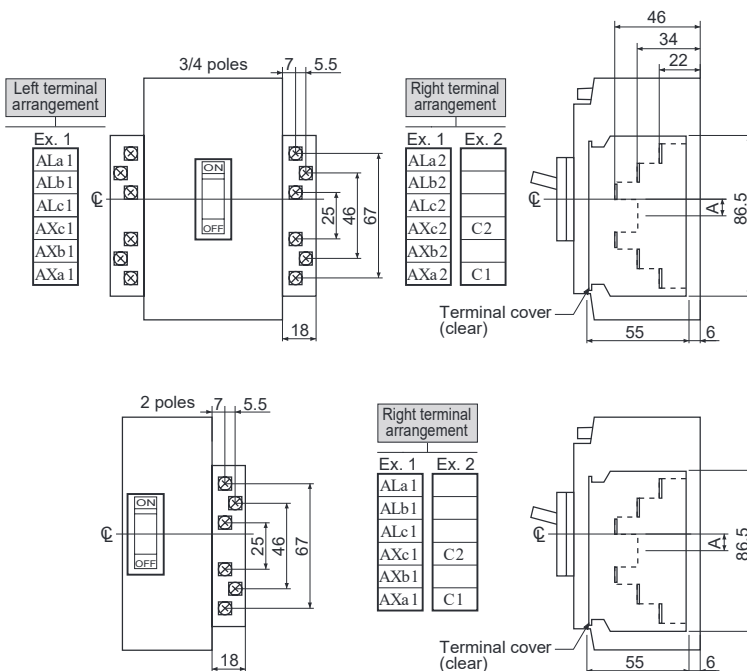

Dimensions, mm

Types of breakers	A
S160-SCF (2/3/4 poles)	9
S160-SF, S160-SCJ, S160-SJ, S160-SN (3/4 poles)	9

Notes:

- 1) Tightening torque of M3.5 terminal screws: 0.9 – 1.2 N·m
- 2) Applicable wire size: 2.0mm² max

6 terminals

Vertical leading type with 250A frame

Mounting position/typical terminal arrangement

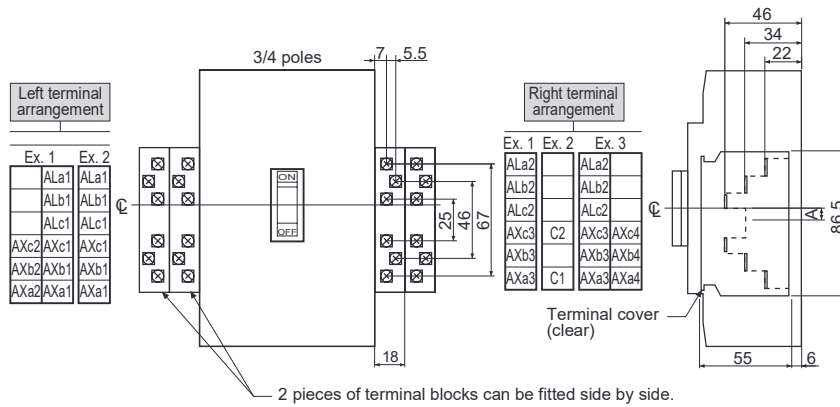

Dimensions, mm

Types of breakers	A
E250-SF, S250-SF, E250-SJ, S250-SJ, S250-SN	7

Notes:

- 1) Tightening torque of M3.5 terminal screws: 0.9 – 1.2 N·m
- 2) Applicable wire size: 2.0mm² max

3

Accessories

Molded Case Circuit Breakers

x Externally mounted accessories

7. Mechanical interlock

Slide interlock (MS)

The slide interlock provides a mechanical interlock between two breakers so that only one of the two can be closed. Moving the slide on the front of the breaker left and right allows activation or deactivation of the interlock.

ASL : Arrangement Standard Line

H : Handle Frame Centre Line

C : Handle Centre Line

Dimensions mm

Types of breakers	Interlock Order codes	Number of poles	a	b	c	d	e	f	g	h	k	m	R	R
E100-SF	XLF1 ⊕	3	100	150	102	26.5	153	52.5	52.5	105	175	99.6	15	8.5

Notes:

1 : Please order with the breakers.

(1) The interlock cannot be applied to breakers equipped with a terminal block, UVT controller or OCR controller.

(2) See the outline dimensions of the breaker for the drilling plan.

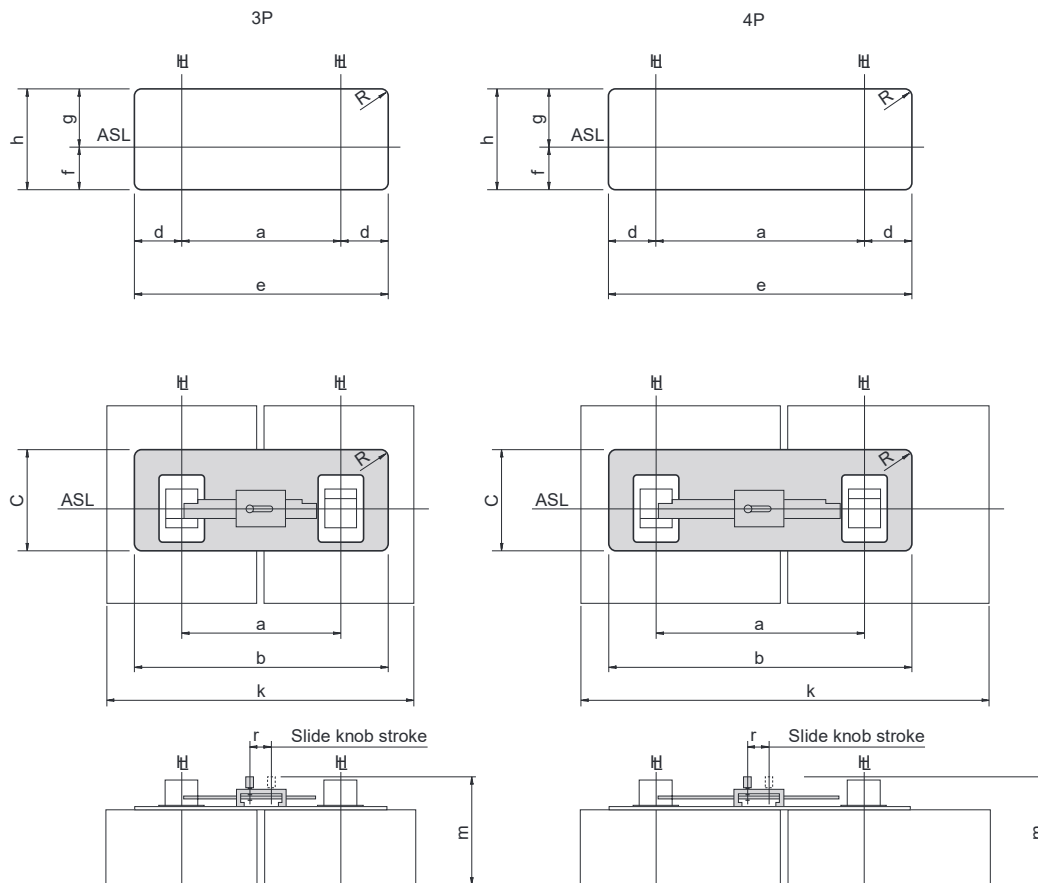

ASL : Arrangement Standard Line
 H : Handle Frame Centre Line
 C : Handle Centre Line

Dimensions mm

Types of breakers	Number of poles	Breaker connection method	Interlock Order codes
S160-SCF, S160-SF, S160-SCJ S160-SJ, S160-SN	3	FC,RC	T2MS16L3SF
	4	FC,RC	T2MS16L4SF

Panel cutout (front view)

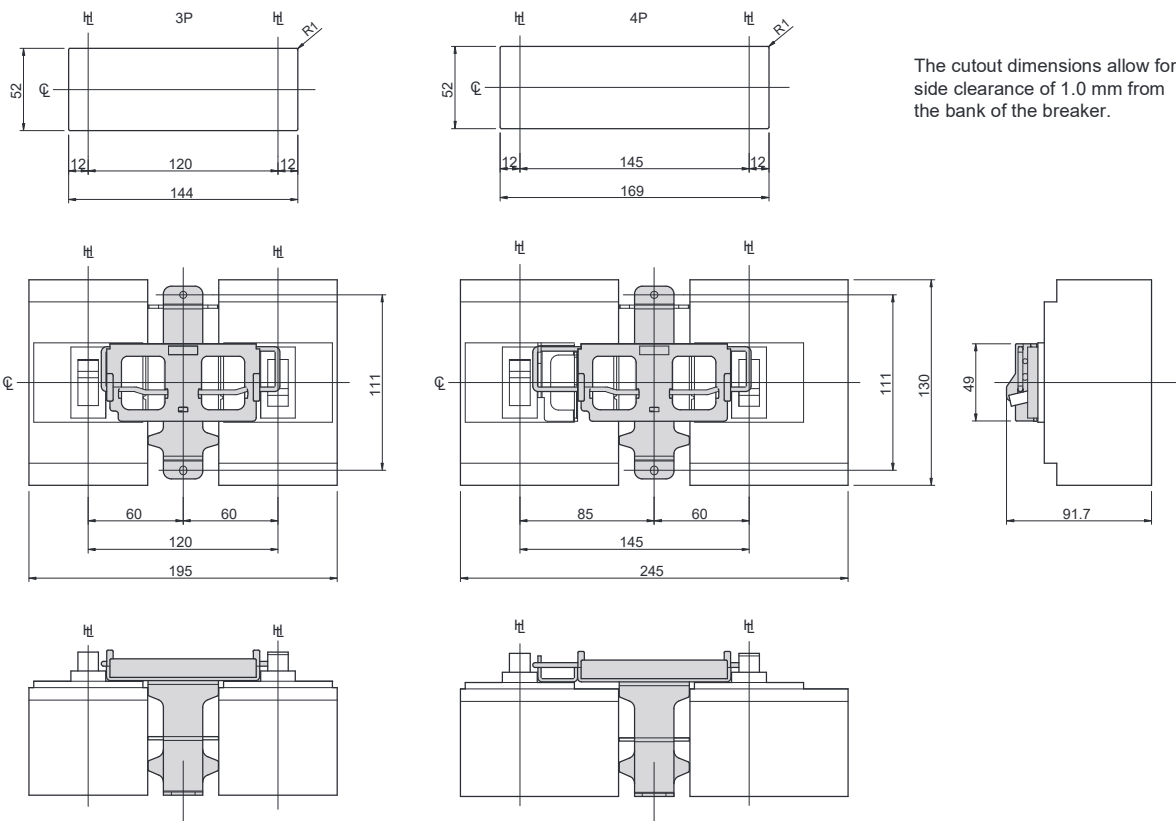

Drilling plan (front view)

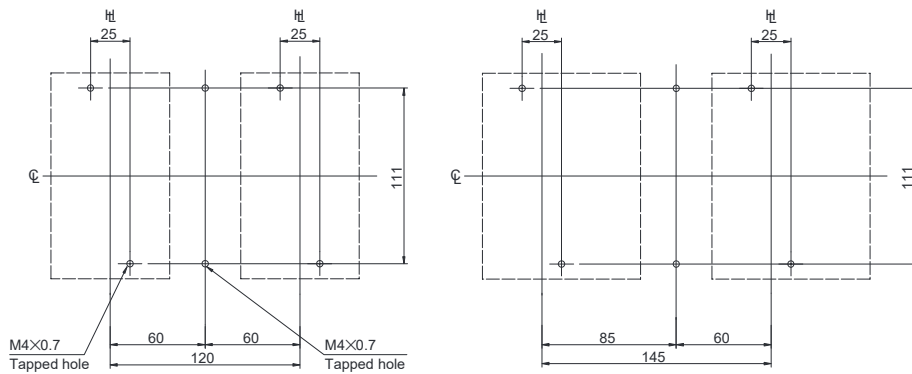

3

Accessories

Molded Case Circuit Breakers

x Externally mounted accessories

7. Mechanical interlock

ASL : Arrangement Standard Line

HL : Handle Frame Centre Line

CL : Handle Centre Line

Dimensions mm

Types of breakers	Number of poles	Breaker connection method	Interlock Order codes
E250-SF, S250-SF, E250-SJ S250-SI, S250-SN	3	FC,RC	T2MS25L3SF
	4	FC,RC	T2MS25L4SF

Panel cutout (front view)

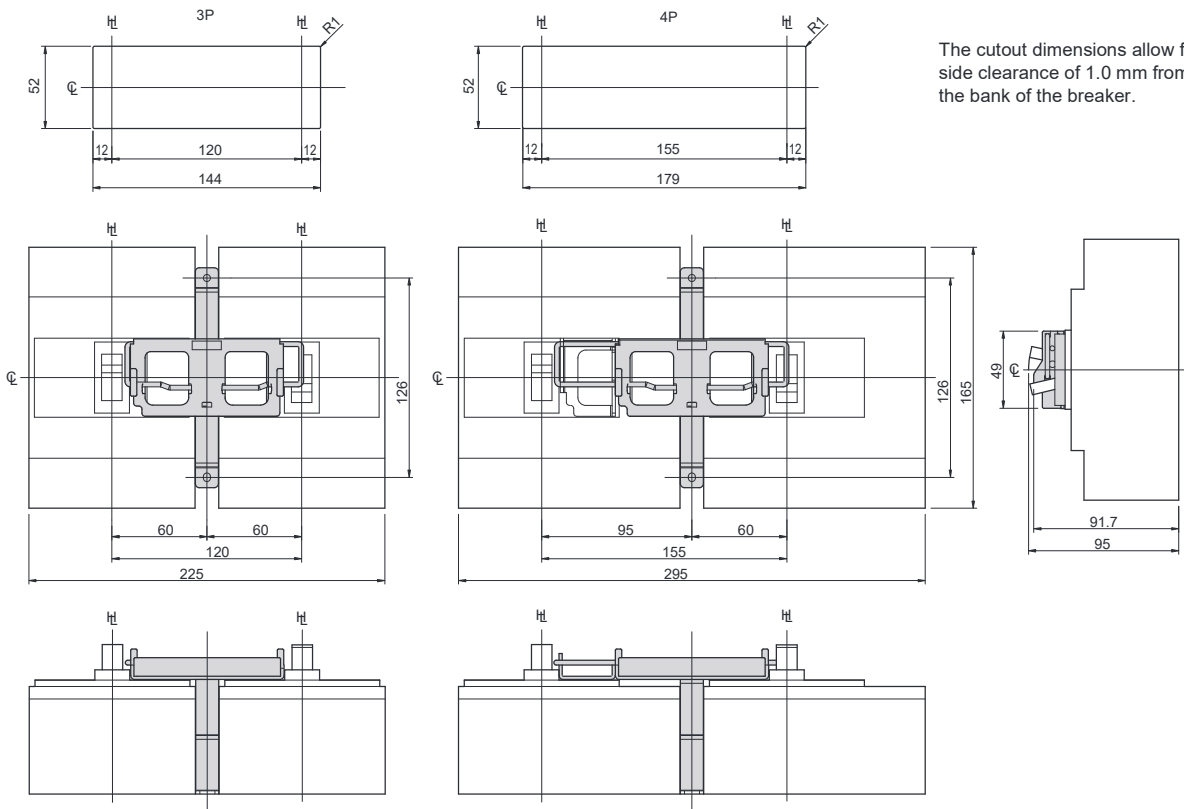

Drilling plan (front view)

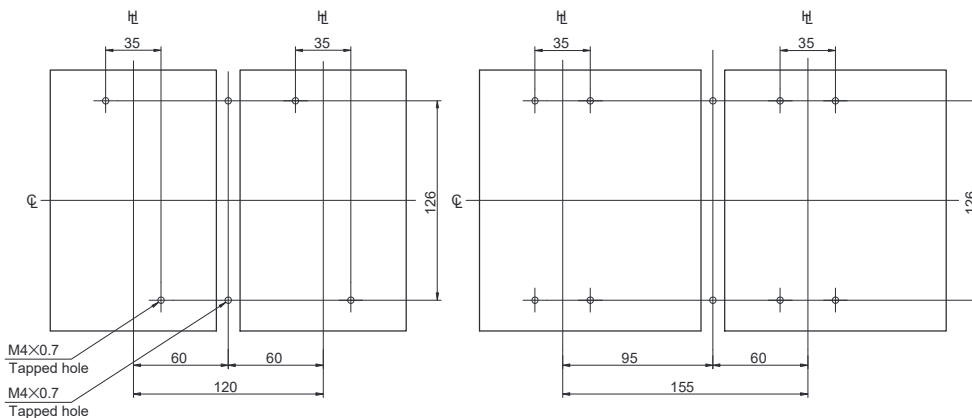

8. Door Flange (D.F)

Door flanges are recommended to be used to cover the cutout of a switchboard panel.

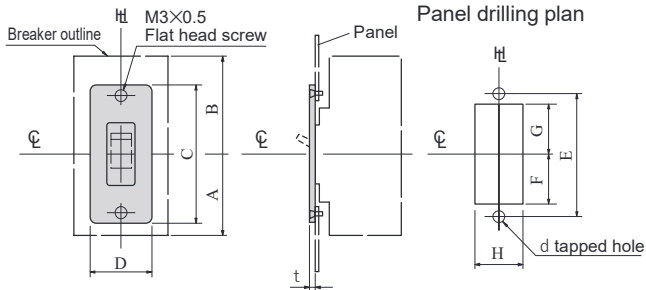

Dimensions mm

Types of breakers	Order codes	A	B	C	D	E	F		G		H		d	t
							Min	Max	Min	Max	Min	Max		
E100-SF	XAA1	65	65	105	50	92	37	42	37	42	32	45	M3x 0.5	3
S160-SCF, S160-SF, S160-SCJ S160-SJ, S160-SN	T2DF25	65	65	105	50	92	37	42	37	42	32	45	M3x 0.5	2
E250-SF, S250-SF, E250-SJ, S250-SJ, S250-SN	T2DF25	82.5	82.5	105	50	92	37	42	37	42	32	45	M3x 0.5	2

4

Characteristics and Outline Dimensions

Molded Case Circuit Breakers

i	E100-SF	4-2
i	E160-SF	4-4
i	S160-SCF, S160-SF	4-6
i	E250-SF, S250-SF	4-8
i	S160-SCJ, S160-SJ	4-10
i	E250-SJ, S250-SJ	4-12
i	S160-SN	4-14
i	S250-SN	4-16

4

Characteristics and Outline Dimensions *TemBreak2*

Molded Case Circuit Breakers

(100A Frame)

E100-SF

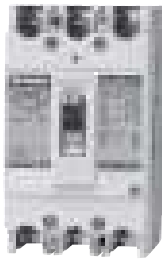

Rating and Specifications

Type	E100-SF					
Number of poles	2	3				
■ Ratings						
Rated current, A	10	50				
Calibrated at 40°C	15	60				
	20	75				
	30	100				
	40					
Rated insulation voltage (U_i) V						
	690					
Rated impulse withstand voltage (U_{imp}) kV						
	6					
Utilization Category						
	A					
■ Rated breaking capacity, kA						
IEC 60947-2	AC	690V	—			
I _{cu} /I _{cs} (sym)		500V	7.5/3.8			
		440V	10/5			
		415V	10/5			
		380V	16/8			
		240V	25/13			
		⊙ DC	250V	7.5/3.8		
		125V	15/7.5			
■ Rated short time withstand current, kA						
	—					
Weight (* marked standard type) kg						
	0.48	0.74				
■ Connections and Mountings						
Front-connected (FC)	Terminal screws	—				
	With straight extension bars	—				
	With spread extension bars	—				
	Cable clamps	○				
Rear-connected (RC)	Bolt studs	○				
	Flat bar studs	—				
Plug-in (PM)	For switchboards Standard (PMC)	—				
	High-performance (PMB)	—				
	For distribution boards (PMC)	—				
Draw-out type (DR)						
	—					
TemPlug70 (PG)						
	—					
TemPlug45B (PG4)						
	—					
DIN rail mount						
	—					
Clip-in chassis mount						
	—					
■ Accessories (optional) Symbol						
Externally mounted	Motor operator	M C	—	•		
	External operating handle	Breaker-mounted H B	—	•		
		Door-mounted (variable depth) H P	—	•		
	Toggle extension	H A	—			
	Mechanical interlock	Slide type M S	—	•		
	Toggle holder	H H	•			
	Toggle lock	H L	•			
	Terminal cover	For front-connected	C F	•		
		For rear-connected and plug-in	C R	•		
		For cable clamps	C S	—		
Interpole barrier	B A	•				
Terminal block for lead	T F	•				
Door flange	D F	•				
■ Standard specifications						
Overcurrent trip mechanism						
	Thermal-magnetic ⁷					
Trip button (color)						
	Yes (Red)					
Handle position indication (ON: Red, OFF: Green)						
	Yes					
Suitability for isolation						
	Non					
CE marking						
	Non					

Notes:
 * : Standard. This configuration used unless otherwise specified. ⊙ : Optional standard. Specify when ordering.
 • : "yes" or "available". — : "no" or "not available". 1 : DC rating available on request.
 7 : Hydraulic-magnetic type for below 10A rating.

Time/Current characteristic curves

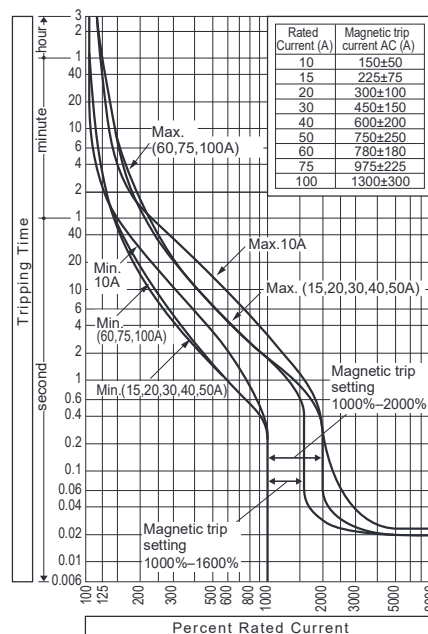

Ambient Compensating Curves

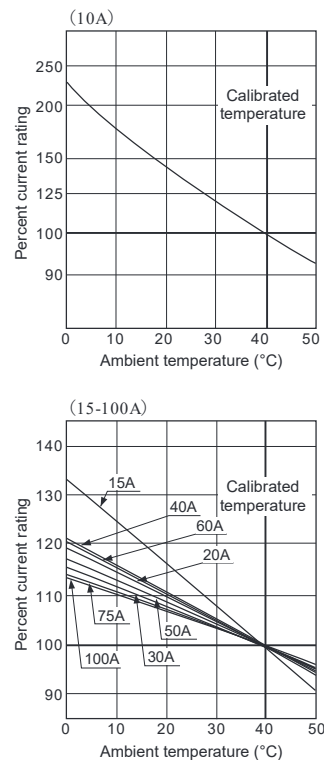

Combinations of Internally Mounted Accessories (Optional)

Poles	AX	AL	SH	UV	AX	AX	AX	AL	AL	AX	AX
	Auxiliary switch	Alarm switch	Shunt trip #1	Under voltage trip #2	AL	SH	UV	SH	UV	AL	UV
3											

NOTE: 2-pole type breaker may incorporate only one combination of [AX (max.2C)], [AL], [SH], [UV], [AX]-[AL] into the left pole.
 NOTE: #1 Shunt trip is provided with anti-burnout switch.
 NOTE: #2 The UV Controller is installed externally when provided with AC UV.

Outline dimensions (mm)

Front-connected

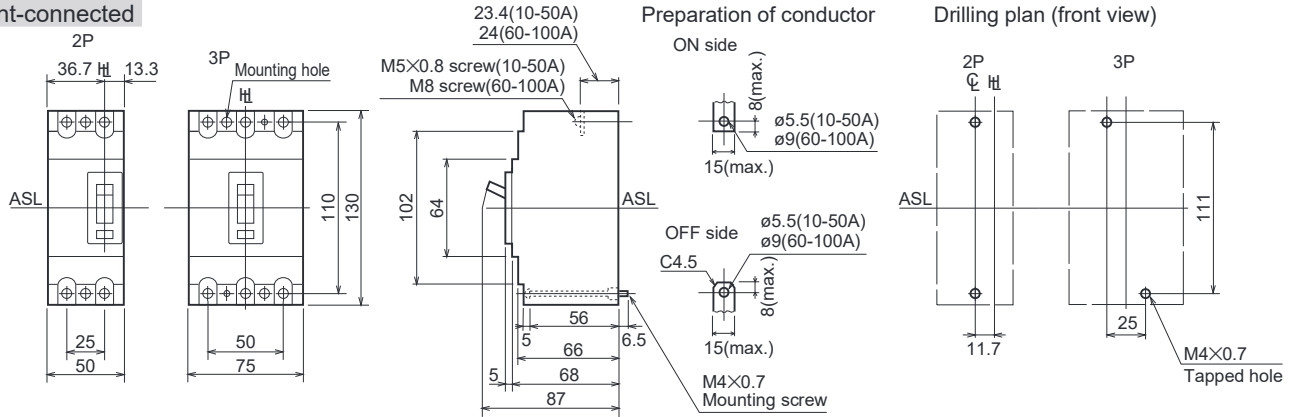

Rear-connected

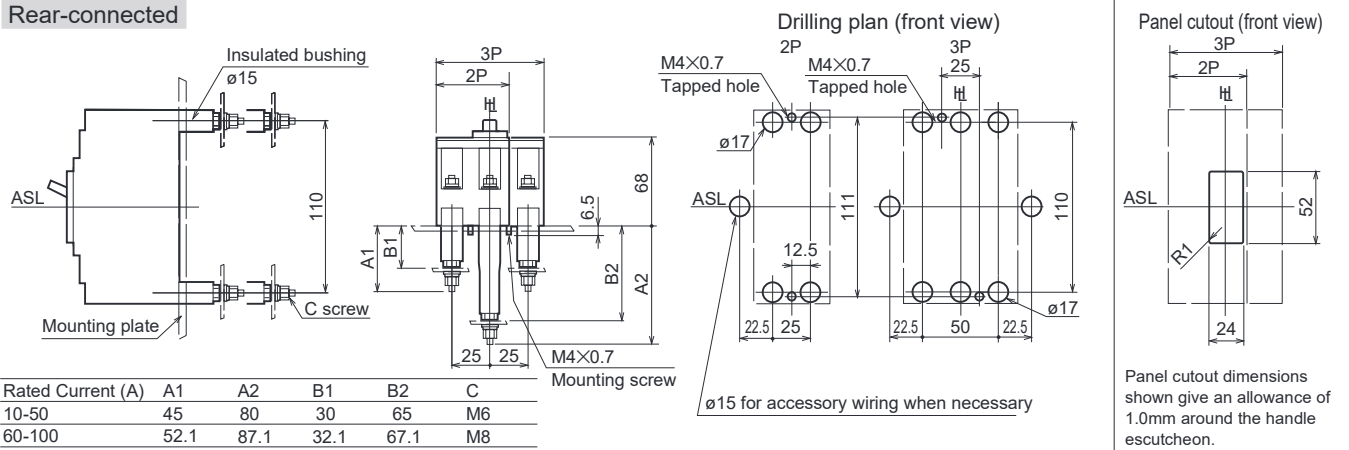

Rated Current (A)	A1	A2	B1	B2	C
10-50	45	80	30	65	M6
60-100	52.1	87.1	32.1	67.1	M8



4

Characteristics and Outline Dimensions *TemBreak2*

Molded Case Circuit Breakers

(160A Frame)

E160-SF

Ratings and Specifications

Type	E160-SF		
Number of poles	1		
■ Ratings			
Rated current, A	16	63	
Calibrated at 45°C	20	80	
	25	100	
	32	125	
	40		
	50		
Rated insulation voltage (U _i) V	690		
Rated impulse withstand voltage (U _{imp}) kV	8		
Utilization Category	A		
■ Rated breaking capacity, kA			
IEC 60947-2	AC	690V	—
I _{cu} /I _{cs} (sym)		500V	—
		440V	—
		415V	—
		380V	—
		240V	25/13
		⊙ DC	250V
		125V	10/5
■ Rated short time withstand current, kA	—		
Weight (* marked standard type) kg	0.3		
■ Connections and Mountings			
Front-connected (FC)	Terminal screws	'	—
	With straight extension bars	○	—
	With spread extension bars	—	—
	Cable clamps	○	—
Rear-connected (RC)	Bolt studs	—	—
	Flat bar studs	—	—
Plug-in (PM)	For switchboards Standard (PMC)	—	—
	High-performance (PMB)	—	—
	For distribution boards (PMC)	—	—
Draw-out type (DR)	—		
TemPlug70 (PG)	—		
TemPlug45B (PG4)	—		
DIN rail mount	—		
Clip-in chassis mount	—		
■ Accessories (optional)	Symbol		
Motor operator	M C	—	—
External operating handle	Breaker-mounted	H B	—
	Door-mounted (variable depth)	H P	—
Toggle extension	H A	—	—
	Mechanical interlock Slide type	M S	—
Externally mounted Toggle holder	H H	•	—
	Toggle lock	H L	•
Terminal cover	For front-connected	C F	•
	For rear-connected and plug-in	C R	—
	For cable clamps	C S	—
Interpole barrier	B A	—	—
Terminal block for lead	T F	—	—
Door flange	D F	•	—
■ Standard specifications			
Overcurrent trip mechanism	Thermal-magnetic		
Trip button (color)	Yes (Red)		
Handle position indication (ON: Red, OFF: Green)	Yes		
Suitability for isolation	Yes		
CE marking	Yes		

Time/Current characteristic curves

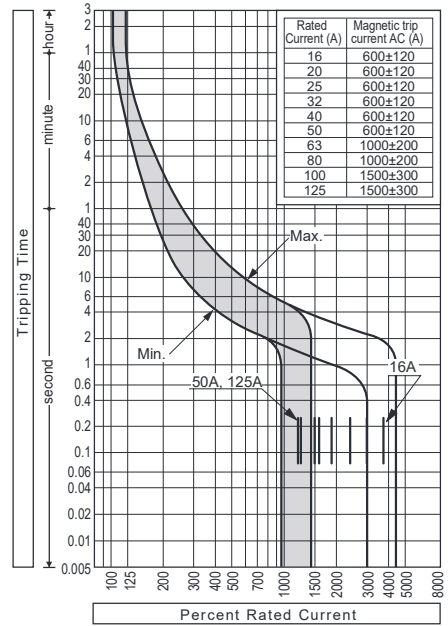

Ambient Compensating Curves

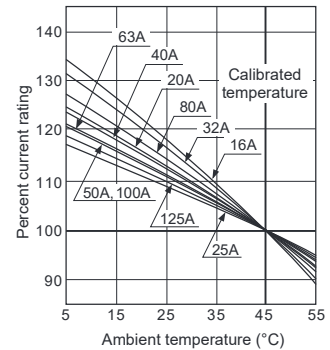

Notes:
 ' : Standard. This configuration used unless otherwise specified. ○ : Optional standard. Specify when ordering.
 • : "yes" or "available". — : "no" or "not available". 1 : DC rating available on request.

Outline dimensions (mm)

E160-SF

Front-connected

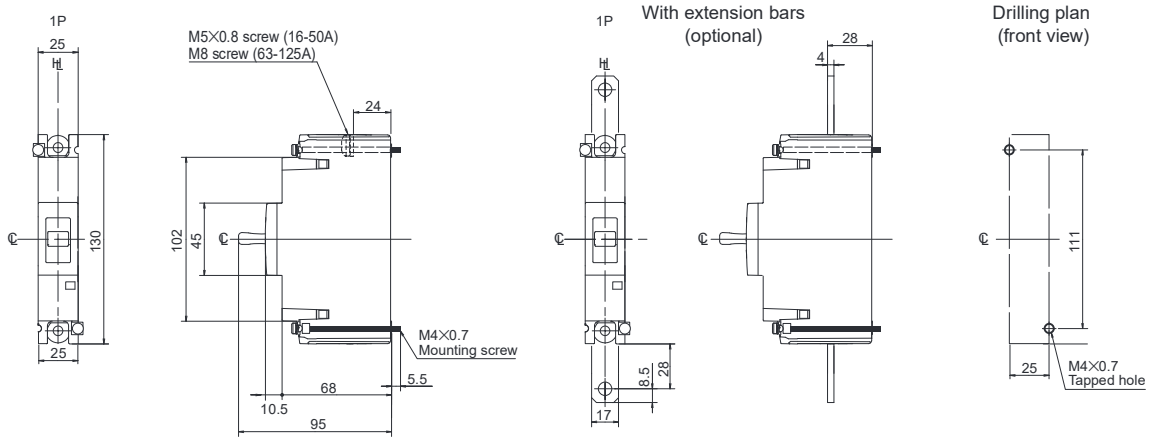

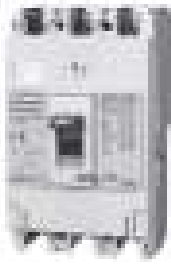

4

Characteristics and Outline Dimensions *TemBreak2*

Molded Case Circuit Breakers

(160A Frame)

S160-SCF, S160-SF

Ratings and Specifications

Type	S160-SCF			S160-SF		
Number of poles	2	3	4	3	4	
■ Ratings						
Rated current, A	15	75		15	75	
Calibrated at 40°C	20	100		20	100	
	30	125		30	125	
	40	160		40	160	
	50			50		
	60			60		
Rated insulation voltage (U_i) V						
	690			690		
Rated impulse withstand voltage (U_{imp}) kV						
	8			8		
Utilization Category						
	A			A		
■ Rated breaking capacity, kA						
IEC 60947-2	AC	690V	—	690V	—	
I _{cu} /I _{cs} (sym)		500V	7.5/4	10/7.5		
		440V	15/7.5	25/13		
		415V	25/13	40/20		
		380V	25/13	40/20		
		240V	35/18	50/25		
	⊙ DC	250V	20/10	25/13		
		125V	30/15	40/20		
■ Rated short time withstand current, kA						
Weight (* marked standard type) kg	0.6	0.8	1.0	0.8	1.0	
■ Connections and Mountings						
Front-connected (FC)	Terminal screws		—	—	—	
	With straight extension bars		○	○	—	
	With spread extension bars		—	○	—	
	Cable clamps		—	—	—	
Rear-connected (RC)	Bolt studs		—	—	—	
	Flat bar studs		○	○	—	
Plug-in (PM)	For switchboards Standard (PMC)		—	—	—	
	High-performance (PMB)		—	—	—	
	For distribution boards (PMC)		—	—	—	
Draw-out type (DR)	—		—	—	—	
TemPlug70 (PG)	—		—	—	—	
TemPlug45B (PG4)	—		—	—	—	
DIN rail mount	—	○ ⊕	—	○ ⊕	—	
Clip-in chassis mount	—		—	—	—	
■ Accessories (optional) Symbol						
Motor operator	M C		—	—	—	
External operating handle	Breaker-mounted		—	●	—	
	Door-mounted (variable depth)		—	●	—	
Toggle extension	H A		—	—	—	
Mechanical interlock	Slide type		—	●	—	
Toggle holder	H H		●	●	—	
Toggle lock	H L		●	●	—	
Terminal cover	For front-connected		●	●	—	
	For rear-connected and plug-in		●	●	—	
	For cable clamps		—	—	—	
Interpole barrier	B A		● ⊕	● ⊕	—	
Terminal block for lead	T F		●	●	—	
Door flange	D F		●	●	—	
■ Standard specifications						
Overcurrent trip mechanism	Thermal-magnetic		—	Thermal-magnetic	—	
Trip button (color)	Yes (Red)		—	Yes (Red)	—	
Handle position indication (ON: Red, OFF: Green)	Yes		—	Yes	—	
Suitability for isolation	Yes		—	Yes	—	
CE marking	Yes		—	Yes	—	

Notes:
 * : Standard. This configuration used unless otherwise specified. ○ : Optional standard. Specify when ordering.
 ● : "yes" or "available". — : "no" or "not available". 1 : DC rating available on request.
 3 : Line side interpole barriers are supplied as standard. (Front connection only) ! 1 Provided with DIN rail adaptor.

Time/Current characteristic curves

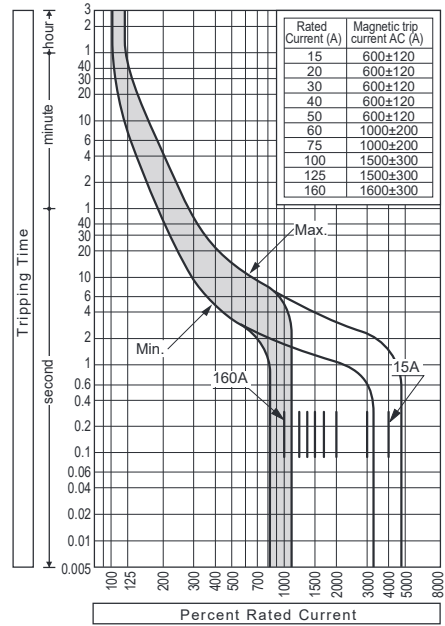

Ambient Compensating Curves

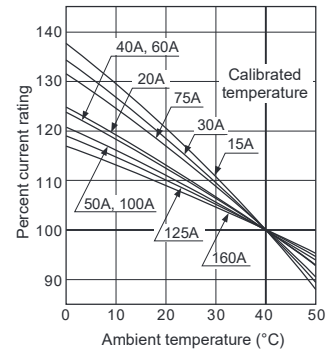

Combinations of Internally Mounted Accessories (Optional)

Poles	AX	AL	SH	UV	AX	AX	AX	AL	AL	AX	AX
	Auxiliary switch	Alarm switch	Shunt trip	Under voltage trip	AL	SH	UV	SH	UV	SH	UV
2+0											
	Toggle	Left pole	Right pole								



4

Characteristics and Outline Dimensions *TemBreak2*

Molded Case Circuit Breakers

(250A Frame)

E250-SF, S250-SF

Ratings and Specifications

Type	E250-SF	S250-SF			
Number of poles	2* 3 4	2* 3 4			
■ Ratings					
Rated current, A	125	125			
Calibrated at 40°C	150	150			
	175	175			
	200	200			
	225	225			
	250	250			
* center pole omitted					
Rated insulation voltage (U _i) V	690	690			
Rated impulse withstand voltage (U _{imp}) kV	8	8			
Utilization Category	A	A			
■ Rated breaking capacity, kA					
IEC 60947-2	AC 690V	—	4/4		
I _{cu} /I _{cs} (sym)	500V	10/7.5	25/13		
	440V	15/12	30/15		
	415V	25/19	40/20		
	380V	25/19	40/20		
	240V	35/27	85/43		
	⊙ DC 250V	15/12	25/13		
		25/19	40/20		
		125V	—	—	
	■ Rated short time withstand current, kA				
	Weight (* marked standard type) kg	1.5 1.5 1.9	1.5 1.5 1.9		
■ Connections and Mountings					
Front-connected (FC)	Terminal screws	—	—		
	With straight extension bars	○	○		
	With spread extension bars	—	○		
	Cable clamps	○	○		
Rear-connected (RC)	Bolt studs	—	—		
	Flat bar studs	○	○		
Plug-in (PM)	For switchboards Standard (PMC)	—	—		
	High-performance (PMB)	—	—		
	For distribution boards (PMC)	—	—		
Draw-out type (DR)	—	—	—		
TemPlug70 (PG)	—	—	—		
TemPlug45B (PG4)	—	—	—		
DIN rail mount	—	—	—		
Clip-in chassis mount	—	—	—		
■ Accessories (optional) Symbol					
Externally mounted	Motor operator	M C	●	●	
	External operating handle	Breaker-mounted H B	●	●	
		Door-mounted (variable depth) H P	●	●	
	Toggle extension	H A	—	—	
	Mechanical interlock	Slide type M S	●	●	
	Toggle holder	H H	●	●	
	Toggle lock	H L	●	●	
	Terminal cover	For front-connected	C F	●	●
		For rear-connected and plug-in	C R	●	●
		For cable clamps	C S	●	●
Interpole barrier		B A	● ⊕	● ⊕	
Terminal block for lead	T F	●	●		
Door flange	D F	●	●		
■ Standard specifications					
Overcurrent trip mechanism	Thermal-magnetic	Thermal-magnetic			
Trip button (color)	Yes (Red)	Yes (Red)			
Handle position indication (ON: Red, OFF: Green)	Yes	Yes			
Suitability for isolation	Yes	Yes			
CE marking	Yes	Yes			

Notes:
 * : Standard. This configuration used unless otherwise specified. ○ : Optional standard. Specify when ordering.
 ● : "yes" or "available". — : "no" or "not available". 1 : DC rating available on request.
 3 : Line side interpole barriers are supplied as standard. (Front connection only)

Time/Current characteristic curves

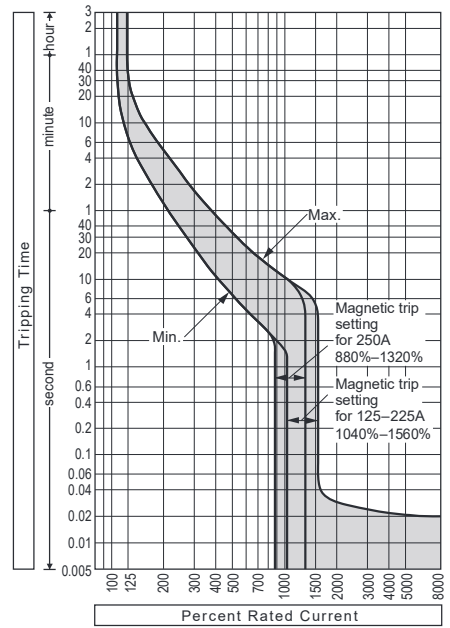

Ambient Compensating Curves

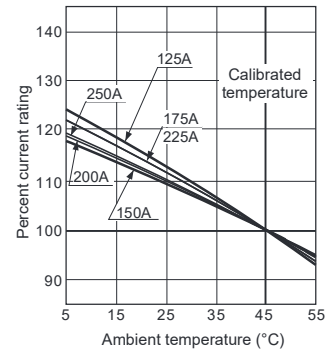

Combinations of Internally Mounted Accessories (Optional)

Poles	AX	AL	SH	UV	AX	AX	AX	AL	AL	AX	AX
	Auxiliary switch	Alarm switch	Shunt trip	Under voltage trip	AL	SH	UV	SH	UV	AL	UV
2-3											
	Left pole										
	Toggle										
	Right pole										

Outline dimensions (mm)

E250-SF, S250-SF

Front-connected

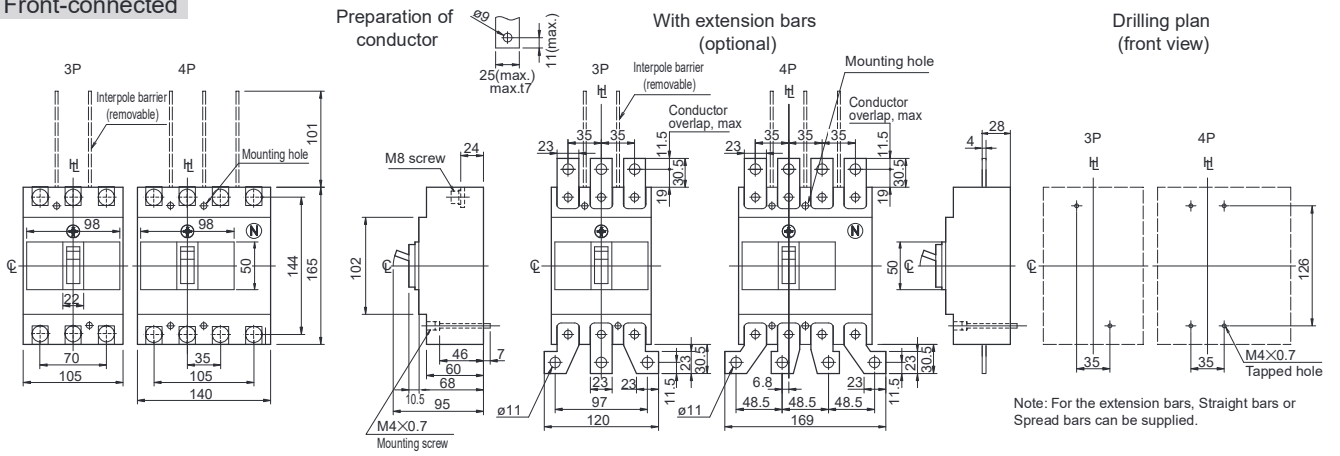

Rear-connected

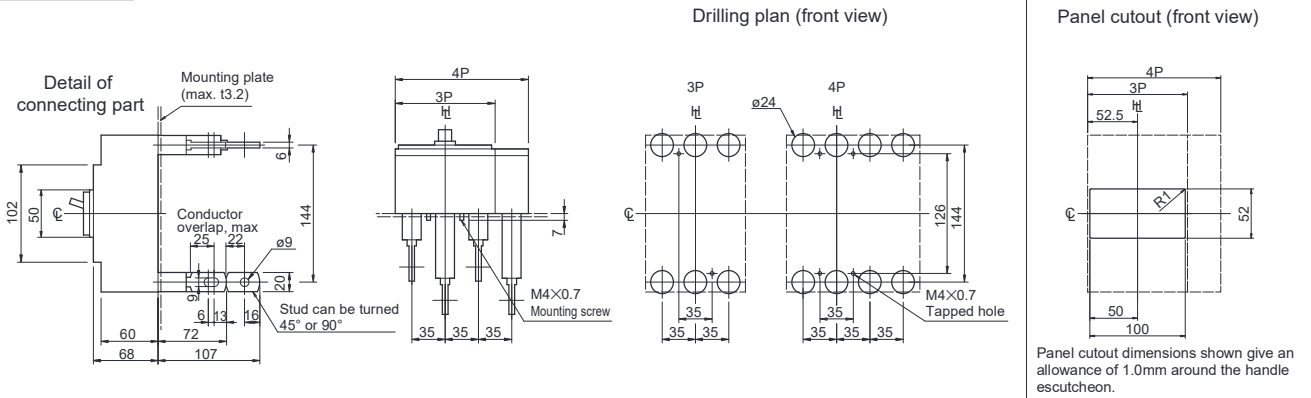



4

Characteristics and Outline Dimensions *TemBreak2*

Molded Case Circuit Breakers

(160A Frame)

S160-SCJ, S160-SJ

Ratings and Specifications

Type	S160-SCJ	S160-SJ		
Number of poles	3 4	3 4		
■ Ratings				
Rated current, A	25	25		
Calibrated at 45°C	40	40		
	63	63		
	80	80		
	100	100		
	125	125		
	160	160		
Rated insulation voltage (U _i) V	690	690		
Rated impulse withstand voltage (U _{imp}) kV	8	8		
Utilization Category	A	A		
■ Rated breaking capacity, kA				
IEC 60947-2	AC	690V	—	6/3
I _{cu} /I _{cs} (sym)		500V	7.5/4	10/7.5
		440V	15/7.5	25/13
		415V	25/13	40/20
		380V	25/13	40/20
		240V	35/18	50/25
⊙ DC		250V	20/10	25/13
		125V	30/15	40/20
■ Rated short time withstand current, kA				
Weight (* marked standard type) kg	0.8	1.0	0.8	1.0
■ Connections and Mountings				
Front-connected (FC)	Terminal screws	⊕	⊕	
	With straight extension bars	○	○	
	With spread extension bars	○	○	
	Cable clamps	○	○	
Rear-connected (RC)	Bolt studs	—	—	
	Flat bar studs	○	○	
Plug-in (PM)	For switchboards Standard (PMC)	—	—	
	High-performance (PMB)	—	—	
	For distribution boards (PMC)	—	—	
Draw-out type (DR)	—	—		
TemPlug70 (PG)	—	—		
TemPlug45B (PG4)	—	—		
DIN rail mount	○ ⊕	○ ⊕		
Clip-in chassis mount	—	—		
■ Accessories (optional) Symbol				
Motor operator	M C	—		
External operating handle	Breaker-mounted	H B	●	●
	Door-mounted (variable depth)	H P	●	●
Toggle extension	H A	—		
Mechanical interlock Slide type	M S	●	●	
Toggle holder	H H	●	●	
Toggle lock	H L	●	●	
Terminal cover	For front-connected	C F	●	●
	For rear-connected and plug-in	C R	●	●
	For cable clamps	C S	●	●
Interpole barrier	B A	● ⊕	● ⊕	
Terminal block for lead	T F	●	●	
Door flange	D F	●	●	
■ Standard specifications				
Overcurrent trip mechanism	Thermal-magnetic	Thermal-magnetic		
Trip button (color)	Yes (Red)	Yes (Red)		
Handle position indication (ON: Red, OFF: Green)	Yes	Yes		
Suitability for isolation	Yes	Yes		
CE marking	Yes	Yes		

Time/Current characteristic curves

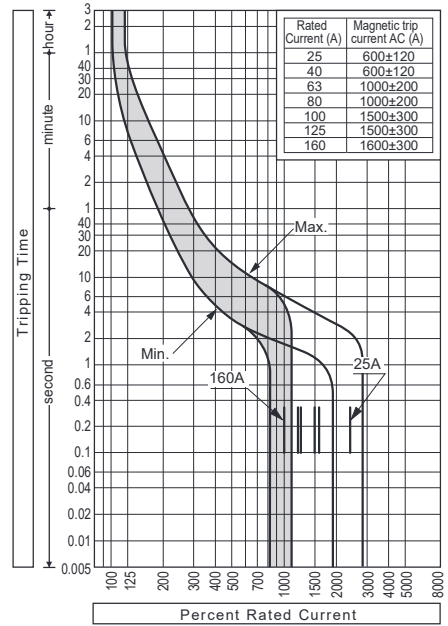

Ambient Compensating Curves

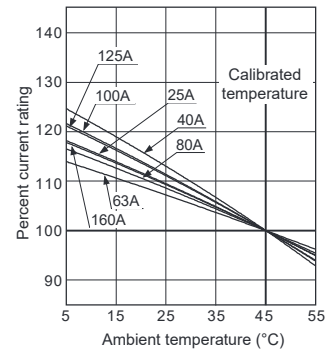

Notes:
 * : Standard. This configuration used unless otherwise specified. ○ : Optional standard. Specify when ordering.
 ● : "yes" or "available". — : "no" or "not available". 1 : DC rating available on request.
 3 : Line side interpole barriers are supplied as standard. (Front connection only) ! 1 Provided with DIN rail adaptor.

Combinations of Internally Mounted Accessories (Optional)

Poles	AX	AL	SH	UV	AX	AX	AX	AL	AL	AX	AX
Auxiliary switch	□	□	□	□	□	□	□	□	□	□	□
Alarm switch	□	□	□	□	□	□	□	□	□	□	□
Shunt trip	□	□	□	□	□	□	□	□	□	□	□
Under voltage trip	■	■	■	■	■	■	■	■	■	■	■
4-3	□	□	□	□	□	□	□	□	□	□	□
Toggle	□	□	□	□	□	□	□	□	□	□	□
Left pole	□	□	□	□	□	□	□	□	□	□	□
Right pole	□	□	□	□	□	□	□	□	□	□	□

Outline dimensions (mm)

S160-SCJ, S160-SJ

Front-connected

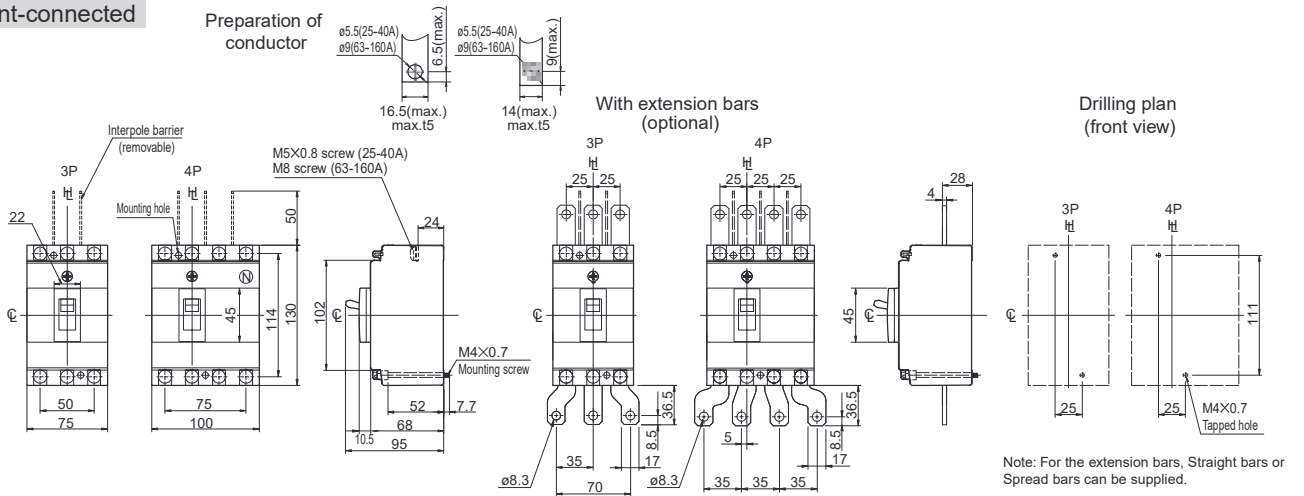

Rear-connected

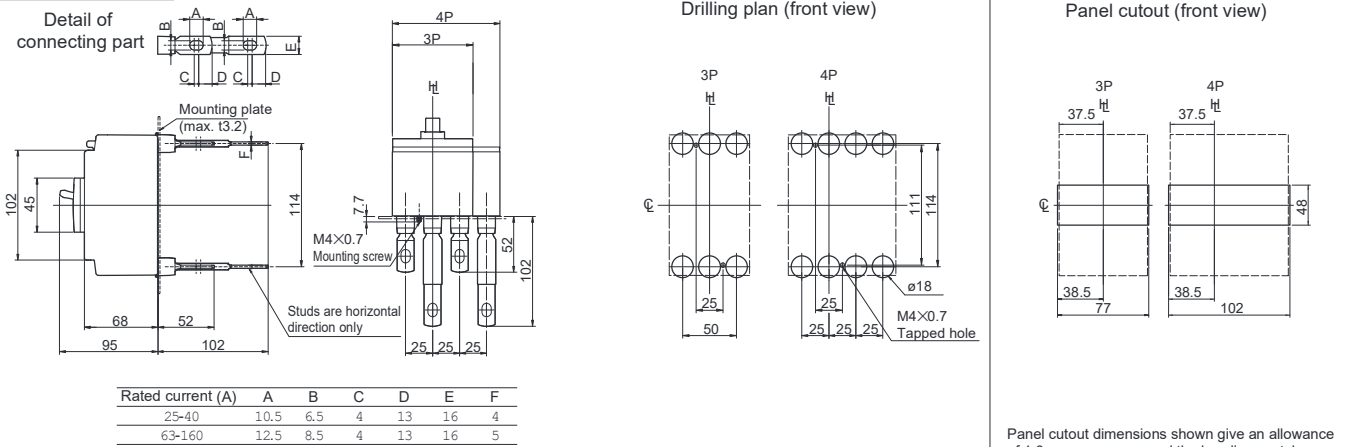

4

Characteristics and Outline Dimensions *TemBreak2*

Molded Case Circuit Breakers

(250A Frame)

E250-SJ, S250-SJ

Rating and Specifications

Type	E250-SJ	S250-SJ			
Number of poles	3 4	3 4			
■ Ratings					
Rated current, A	100	160			
Calibrated at 45°C	125	200			
	160	250			
	200				
	250				
<hr/>					
Rated insulation voltage (U _i) V	800	800			
Rated impulse withstand voltage (U _{imp}) kV	8	8			
Utilization Category	A	A			
■ Rated breaking capacity, kA					
IEC 60947-2	AC 690V	—	4/4		
I _{cu} /I _{cs} (sym)	500V	7.5/6	10/7.5		
	440V	15/12	30/15		
	415V	25/19	40/20		
	380V	25/19	40/20		
	240V	35/27	85/43		
⊙ DC	250V	15/12	25/13		
	125V	25/19	40/20		
■ Rated short time withstand current, kA					
Weight (1' marked standard type) kg	1.5 1.9	1.5 1.9			
■ Connections and Mountings					
Front-connected (FC)	Terminal screws	—	—		
	With straight extension bars	○	○		
	With spread extension bars	○	○		
	Cable clamps	○	○		
Rear-connected (RC)	Bolt studs	—	—		
	Flat bar studs	○	○		
Plug-in (PM)	For switchboards Standard (PMC)	—	—		
	High-performance (PMB)	—	—		
	For distribution boards (PMC)	—	—		
Draw-out type (DR)	—	—			
TemPlug70 (PG)	—	—			
TemPlug45B (PG4)	—	—			
DIN rail mount	—	—			
Clip-in chassis mount	—	—			
■ Accessories (optional) Symbol					
Externally mounted	Motor operator	M C	●		
	External operating handle	Breaker-mounted H B	●		
	Door-mounted (variable depth) H P		●		
Externally mounted	Toggle extension	H A	—		
	Mechanical interlock Slide type	M S	●		
	Toggle holder	H H	●		
	Toggle lock	H L	●		
	Terminal cover	For front-connected	C F	●	
		For rear-connected and plug-in	C R	●	
		For cable clamps	C S	●	
	Interpole barrier	B A	● ⊕		
	Terminal block for lead	T F	●		
	Door flange	D F	●		
■ Standard specifications					
Overcurrent trip mechanism	Thermal-magnetic	Thermal-magnetic			
Trip button (color)	Yes (Red)	Yes (Red)			
Handle position indication (ON: Red, OFF: Green)	Yes	Yes			
Suitability for isolation	Yes	Yes			
CE marking	Yes	Yes			

Notes:
 1' : Standard. This configuration used unless otherwise specified. ⊙ : Optional standard. Specify when ordering.
 ● : "yes" or "available". — : "no" or "not available". 1 : DC rating available on request.
 3 : Line side interpole barriers are supplied as standard. (Front connection only)

Time/Current characteristic curves

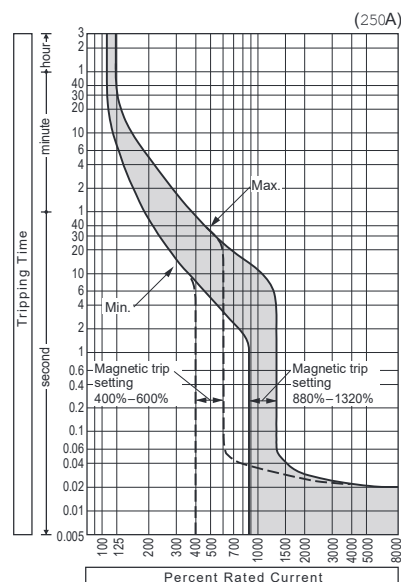
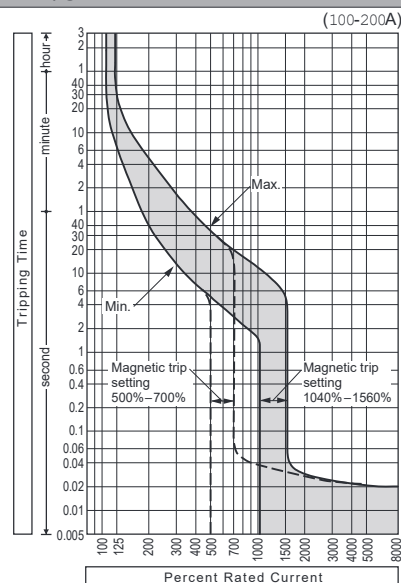

Ambient Compensating Curves

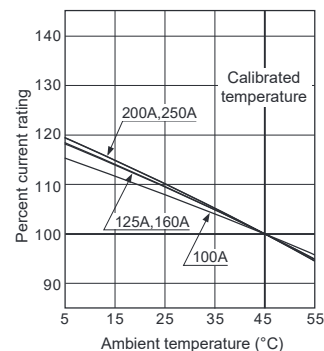

Combinations of Internally Mounted Accessories (Optional)

Poles	AX	AL	SH	UV	AX	AX	AX	AL	AL	AX	AX
	Auxiliary switch	Alarm switch	Shunt trip	Under voltage trip	AL	SH	UV	SH	UV	SH	UV
3-4											
	Left pole	Right pole	Toggle								

Outline dimensions (mm)

E250-SJ, S250-SJ

Front-connected

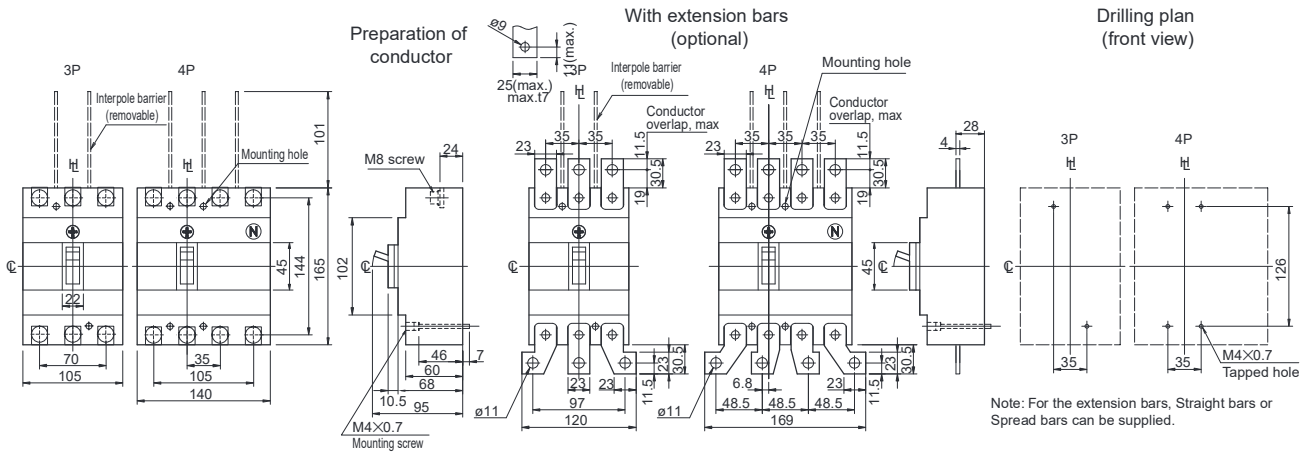

Rear-connected

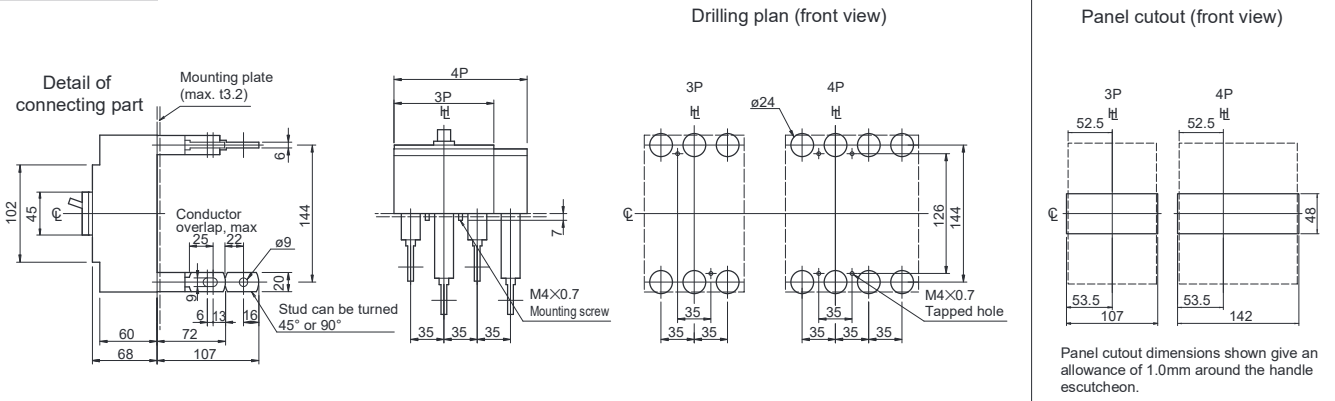

4

S160-SN

Ratings and Specifications

Type	S160-SN					
Number of poles	3	4				
■ Ratings						
Rated current, A	160					
Rated insulation voltage (U _i) V	690					
Rated operational voltage V	AC	690				
	DC	250				
Rated short circuit making capacity, kA peak	2.8					
Rated short time withstand current, kA	2(0.3sec)					
Rated impulse withstand voltage (U _{imp}) kV	8					
■ Performance						
Utilization category	AC	690V	AC-23A			
IEC 60947-3	DC	250V	DC-22A			
Upstream breaker (OCPD) @9	S160-SF					
Weight (* marked standard type) kg	0.7	0.9				
■ Connections and Mountings						
Front-connected (FC)	Terminal screws	'				
	With straight extension bars	o				
	With spread extension bars	o				
	Cable clamps	o				
Rear-connected (RC)	Bolt studs	—				
	Flat bar studs	o				
Plug-in (PM)	For switchboards Standard (PMC)	—				
	High-performance (PMB)	—				
	For distribution boards (PMC)	—				
Draw-out type (DR)	—					
TemPlug70 (PG)	—					
TemPlug45B (PG4)	—					
DIN rail mount	o ⊕					
Clip-in chassis mount	—					
■ Accessories (optional) Symbol						
Externally mounted	Motor operator	M C	—			
	External operating handle	H B	•			
	Door-mounted (variable depth)	H P	•			
	Toggle extension	H A	—			
	Mechanical interlock Slide type	M S	•			
	Toggle holder	H H	•			
	Toggle lock	H L	•			
	Terminal cover	For front-connected	C F	•		
		For rear-connected and plug-in	C R	•		
		For cable clamps	C S	•		
	Interpole barrier	B A	• e			
	Terminal block for lead	T F	•			
	Door flange	D F	•			
■ Standard specifications						
Trip button (color)	Yes (Red)					
Handle position indication (ON: Red, OFF: Green)	Yes					
Suitability for isolation	Yes					
CE marking	Yes					

Notes:

- ' : Standard. This configuration used unless otherwise specified.
- o : Optional standard. Specify when ordering.
- : "yes" or "available".
- : "no" or "not available".
- 3 : Line side interpole barriers are supplied as standard. (Front connection only)
- ! † Provided with DIN rail adaptor.
- @9 Required for overcurrent protection. Rated conditional short-circuit current [I_{cc}] will be the same as Rated short-circuit breaking capacity of upstream breaker.

Combinations of Internally Mounted Accessories (Optional)

Poles	AX	AL	SH	UV	AX	AX	AX	AL	AL	AX	AX
	Auxiliary switch	Alarm switch	Shunt trip	Under voltage trip	AX	SH	UV	SH	UV	AX	AL
3-4											
	Left pole	Right pole	Toggle								

Outline dimensions (mm)

S160-SN

Front-connected

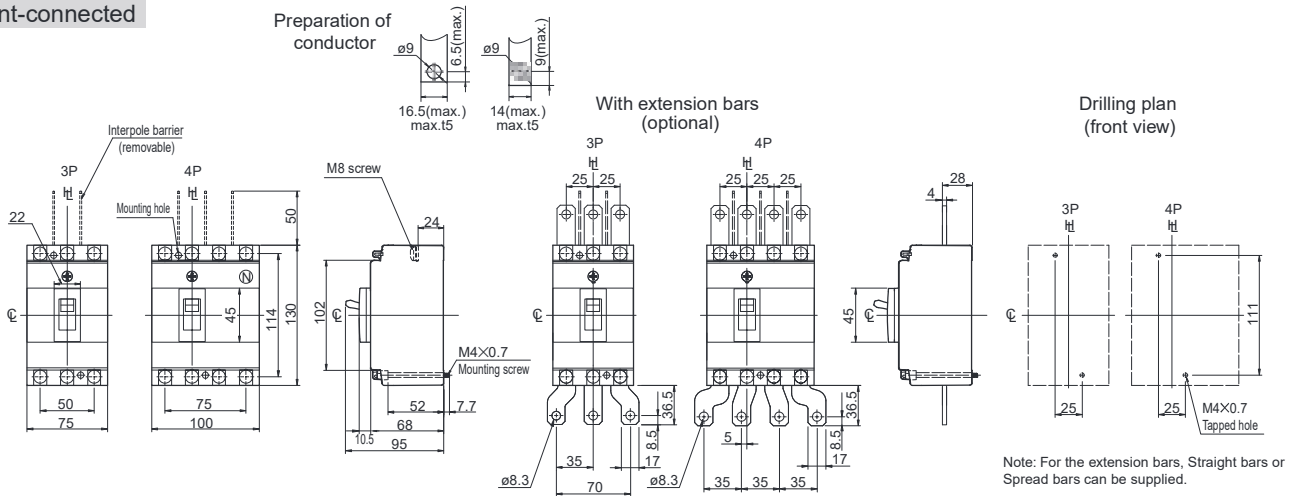

Rear-connected

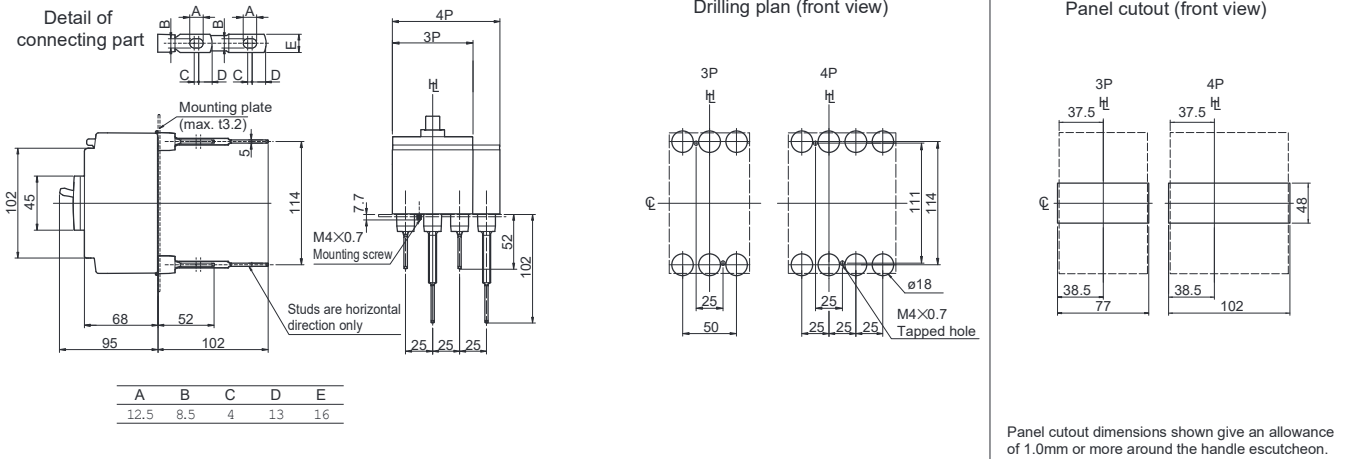

4

S250-SN

Ratings and Specifications

Type	S250-SN					
Number of poles	3	4				
■ Ratings						
Rated current, A	250					
Rated insulation voltage (U _i) V	800					
Rated operational voltage V	AC	690				
	DC	250				
Rated short circuit making capacity, kA peak	6					
Rated short time withstand current, kA	3(0.3sec)					
Rated impulse withstand voltage (U _{imp}) kV	8					
■ Performance						
Utilization category	AC	690V	AC-23A			
IEC 60947-3	DC	250V	DC-22A			
Upstream breaker (OCPD) @9	S250-SF					
Weight (* marked standard type) kg	1.5	1.9				
■ Connections and Mountings						
Front-connected (FC)	Terminal screws	*				
	With straight extension bars	o				
	With spread extension bars	o				
	Cable clamps	o				
Rear-connected (RC)	Bolt studs	—				
	Flat bar studs	o				
Plug-in (PM)	For switchboards Standard (PMC)	—				
	High-performance (PMB)	—				
	For distribution boards (PMC)	—				
Draw-out type (DR)	—					
TemPlug70 (PG)	—					
TemPlug45B (PG4)	—					
DIN rail mount	—					
Clip-in chassis mount	—					
■ Accessories (optional) Symbol						
Externally mounted	Motor operator	M C	•			
	External operating handle	Breaker-mounted H B	•			
	Door-mounted (variable depth)	H P	•			
	Toggle extension	H A	—			
	Mechanical interlock	Slide type M S	•			
	Toggle holder	H H	•			
	Toggle lock	H L	•			
	Terminal cover	For front-connected	C F	•		
		For rear-connected and plug-in	C R	•		
		For cable clamps	C S	•		
	Interpole barrier	B A	• e			
	Terminal block for lead	T F	•			
	Door flange	D F	•			
	■ Standard specifications					
Trip button (color)	Yes (Red)					
Handle position indication (ON: Red, OFF: Green)	Yes					
Suitability for isolation	Yes					
CE marking	Yes					

Notes:

* : Standard. This configuration used unless otherwise specified.

o : Optional standard. Specify when ordering.

• : "yes" or "available".

— : "no" or "not available".

3 : Line side interpole barriers are supplied as standard. (Front connection only)

@9 Required for overcurrent protection. Rated conditional short-circuit current [I_{cc}] will be the same as Rated short-circuit breaking capacity of upstream breaker.

Combinations of Internally Mounted Accessories (Optional)

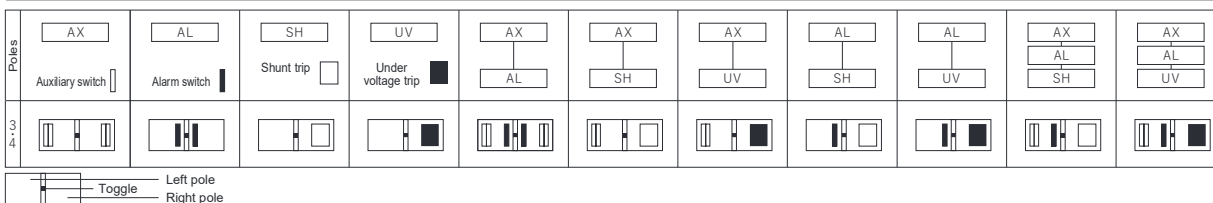

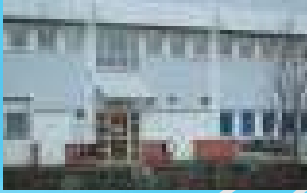

TERASAKI ELECTRIC (EUROPE) LTD.
FILIAL SVERIGE
(Sweden)

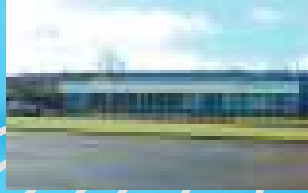

TERASAKI ELECTRIC (EUROPE) LTD.
(United Kingdom)

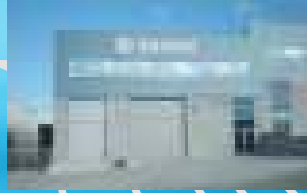

TERASAKI ELECTRIC (EUROPE) LTD.
SU CURSAL EN ESPAÑA
(Spain)



TERASAKI ELECTRIC (EUROPE) LTD.
FILIALE ITALIA
(Italy)

TERASAKI Global Network



TERASAKI ELECTRIC CO., LTD.
(Head Quarters, Japan)



TERASAKI ELECTRIC
(M) SDN. BHD.
(Malaysia)



TERASAKI CIRCUIT
BREAKERS (S) PTE LTD.
TERASAKI ELECTRIC CO.,
(FAR EAST) PTE LTD.
(Singapore)

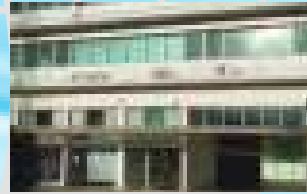

TERASAKI DO BRASIL LTDA.
(Brazil)

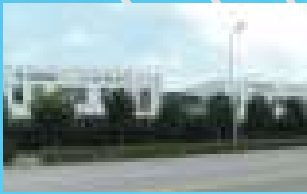

TERASAKI ELECTRIC
(SHANGHAI) CO., LTD.
(China)



TERASAKI ELECTRIC
(CHINA) LTD.
(China)

Since 1971 when we established TERASAKI ELECTRIC Europe, our first overseas subsidiary, in the UK, we have assembled a global network of 10 overseas subsidiaries and 72 agents to provide sales and technical supports to customers worldwide.

Safety Notice

Carefully read instruction manual to ensure proper installation, connection, operation, handling and maintenance of the product.

TERASAKI ELECTRIC CO., LTD.

Head Office: 6-13-47 Kamihigashi, Hirano-ku, Osaka 547-0002, Japan

Circuit Breaker Division: 6-13-47 Kamihigashi, Hirano-ku, Osaka 547-0002, Japan

TEL +81-6-6791-2763

FAX +81-6-6791-2732

int-sales@terasaki.co.jp

<http://www.terasaki.co.jp/>

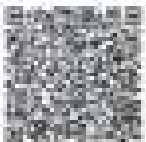

Latest data can download by matrix code.

JAN. 2018

Catalogue No. '18-! 64E

Ratings and specifications are subject to change without notice.