

Medium Voltage Switching Devices

HVX

Vacuum circuit-breaker 12–36 kV

Assembly

Operation

Maintenance

No. AGS 531 301-01

Edition 01/2011

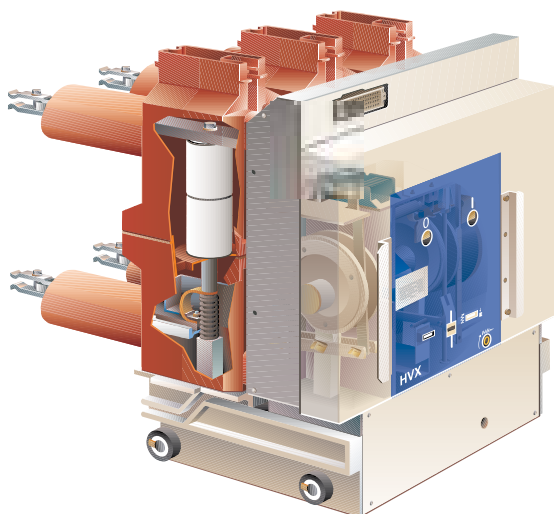

Editor:

Schneider Electric Sachsenwerk GmbH
Rathenaustrasse 2
D-93055 Regensburg, Germany

 +49 (0) 9 41 46 20-0

 +49 (0) 9 41 46 20-418

© Schneider Electric 2011

All rights reserved to this technical manual.

Reproduction and making available of this technical manual, or extracts, to third parties are prohibited. Only integral reproduction of this technical manual is permitted with the written permission from Schneider Electric.

Electronic copies in e.g. PDF-format or scanned version have the status "for information only".

The only valid version of this technical manual is always enclosed directly to the product in question by the factory.

Remarks on this manual	4
Purpose and target group.....	4
Reference documents.....	4
Terms and symbols used.....	4
Abbreviations used.....	4
Any questions or suggestions?.....	4
1 Safety Provisions	5
2 Variants and technical details	6
2.3 Dimensions.....	10
2.4 Applied standards.....	10
2.5 Environmental and operating conditions.....	10
2.6 Nameplate.....	11
2.7 Technical data of electrical control and operating devices.....	12
2.8 Intended use.....	14
2.9 Disposal after the end of service life.....	14
3 Packaging, transport, storage	15
3.1 Shipping units.....	15
3.2 Transport.....	16
3.3 Delivery.....	16
3.4 Storage.....	16
4 Assembly	17
4.1 Safety provisions and instructions for assembly.....	17
4.2 Transport using a crane.....	17
4.3 Mechanical assembly of the fixed version HVX-F.....	19
4.4 Earth terminal.....	22
4.5 Connecting conductor bars.....	23
4.6 Mounting the circuit-breaker HVX-E (truck-type).....	25
4.7 Connecting the control lines.....	27
5 Commissioning	29
5.1 Final steps.....	29
5.2 Checking switching functions and interlocks.....	29
5.3 Checks for the circuit-breaker HVX in conjunction with panels/switching cells.....	30
6 Operation	31
6.1 Operator interface.....	31
6.2 Operation accessories.....	33
6.3 Interlocks.....	34
6.4 Operating specifications.....	35
6.5 Charging the energy storing device.....	36
6.6 Switching operations.....	37
6.7 Position indicators on circuit-breaker and possible operating sequences.....	37
6.8 Moving truck into service / disconnected position.....	38
7 Maintenance	40
7.1 Safety provisions.....	40
7.2 Maintenance and maintenance specifications.....	40
7.3 Cleaning insulating components.....	41
7.4 Avoiding condensation.....	41
7.5 Corrosion protection.....	41
7.6 Replacement of components.....	41
7.7 Lubrication instructions.....	42
7.8 Maximum admissible numbers of breaking operations of vacuum chamber.....	46
8 Annex	47
8.1 Auxiliary products.....	47
8.2 Treatment of firmly screw-connected contact surfaces.....	47
8.3 Specifications for screw connections.....	48

As our products are subject to continuous further development, we reserve the right to make changes regarding standards, illustrations and technical data.

All dimensions specified in this manual are in millimeters.

Purpose and target group

This Technical Manual describes transport, assembly, operation and maintenance of the series HVX vacuum circuit-breakers. It is exclusively intended for specialist electricians who have been certified for the HVX series (training certificate).

This Technical Manual is an integral part of the product and must be kept accessible at all times to persons performing assembly, operation of or maintenance on the circuit-breaker. If the circuit-breaker is sold to new owners, they must receive this document along with the switching device.

This Technical Manual cannot describe every imaginable individual case or every customer-specific version of the product. For information which is not included in this manual, please contact the manufacturer.

Reference documents

The following additional documents must be complied with:

- Purchase agreement with the stipulations regarding the switch-specific equipment and the legal details
- Switch-specific circuit diagrams and documentation
- Project notes regarding the HVX circuit breaker
- For assembly and operation of the circuit-breaker, the operating manual of the switchgear in which it is operated must be complied with.

Terms and symbols used

This manual uses certain terms and symbols. They warn about dangers or provide important information which must be complied with at all costs so as to avoid danger and damage:



"Danger!"

This danger symbol warns about dangerous electrical voltage. Contact with voltage may result in fatal injury!



"Warning!"

This danger symbol warns about the risk of injury. Please comply with all the provisions identified by this symbol in order to avoid death or serious injury.



"Important:"

This instruction symbol is used for information which is important to avoid material damage.

Abbreviations used

HVX-F: HVX circuit-breaker for fixed mounting

HVX-E: HVX circuit-breaker for truck-mounting

U_r : Rated voltage

I_r : Rated current

I_{sc} : Rated short-circuit breaking current

Any questions or suggestions?

Do you have any questions or suggestions regarding this manual, or do you require further information?

We always strive to provide you with the best-possible information for optimum, safe use of our products. Thus, do not hesitate to contact us if you have any recommendations, amendments or proposals for improvement.

Applicable standards and regulations:

The work described in this manual may only be performed by specialist electricians who have proved their experience with the HVX series and the applicable safety provisions.

Please read the whole manual carefully before working on the circuit-breaker.

- High-voltage switchgear and control gear, part 100: AC circuit-breaker (IEC 62271-100)
- The locally applicable accident prevention, operating and work instructions must be complied with.
- Installation: IEC 61936-1/HD 637 S¹
- Operation of electrical equipment: EN 50110-1¹

¹ The national standards applicable in the country where the equipment is to be installed must be complied with.

Before performing work on the circuit-breaker, it is essential that you comply with the following instructions:



Danger!

Risk of fatalities due to high voltage. Isolation from high voltage and earthing must always be ensured before performing assembly or maintenance work.



Danger!

Risk of fatalities due to high supply voltage. Isolation from supply voltage must always be ensured before performing assembly or maintenance work.



Warning!

Risk of injury due to movable parts in mechanical drives. For maintenance work,

– isolate from supply voltage

– release the circuit-breaker's energy storing device by switching it OFF-ON-OFF (see page 37)

Behaviour in case of incidents or accidents

In case of fire or of internal faults, toxic and caustic decomposition products may be produced. Comply with the locally applicable accident and safety provisions.

In case of personal injury, take first-aid measures or cause them to be taken.

2.1 Vacuum circuit-breaker HVX-E (truck-mounted version)

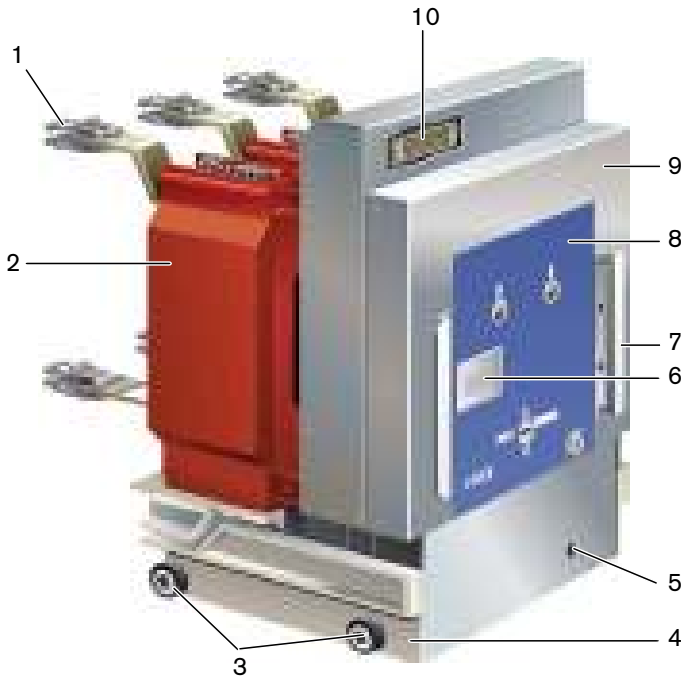

Rated voltage U_r	[kV]	≤ 12
Rated lightning impulse withstand voltage U_p	[kV]	75
Rated power frequency withstand voltage U_d	[kV]	28
Rated normal current I_r	[A]	≤ 1250
Rated short-circuit breaking current I_{sc}	[kA]	≤ 25
Rated short-time current I_k (3 s)	[kA]	≤ 25
Rated frequency f_r	[Hz]	50/60
Weight (without packaging)	[kg]	approx. 135

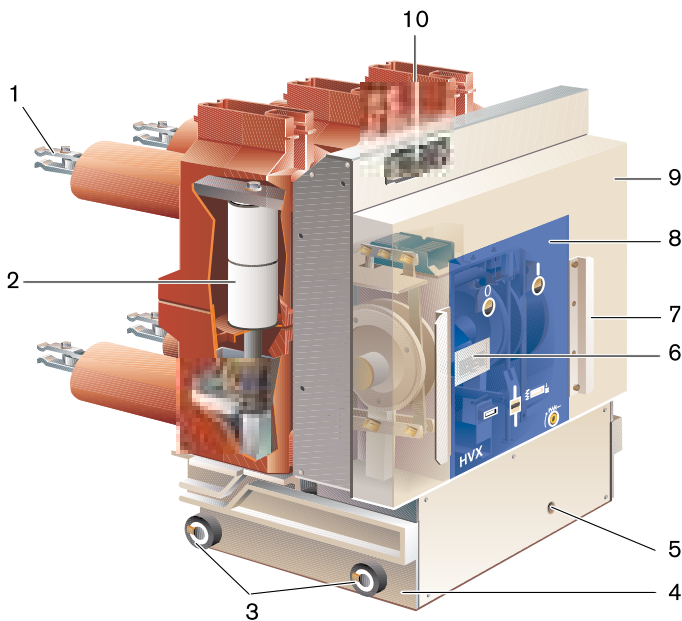

Rated voltage U_r	[kV]	≤ 24
Rated lightning impulse withstand voltage U_p	[kV]	125
Rated power frequency withstand voltage U_d	[kV]	50
Rated normal current I_r	[A]	≤ 2500
Rated short-circuit breaking current I_{sc}	[kA]	≤ 40
Rated short-time current I_k (3 s)	[kA]	≤ 40
Rated frequency f_r	[Hz]	50/60
Weight (without packaging)	[kg]	approx. 160

Fig. 1 Models of the vacuum circuit-breaker HVX-E

- | | |
|--|--|
| 1 Moving contacts | 6 Nameplate |
| 2 Vacuum interrupter chambers | 7 Handles |
| 3 Rollers | 8 Operator interface |
| 4 Truck for PI-, PIB- and PIX panels | 9 Drive casing |
| 5 Insertion opening for crank to move the circuit-breaker into its disconnected/service position | 10 Low-voltage connector for control lines |

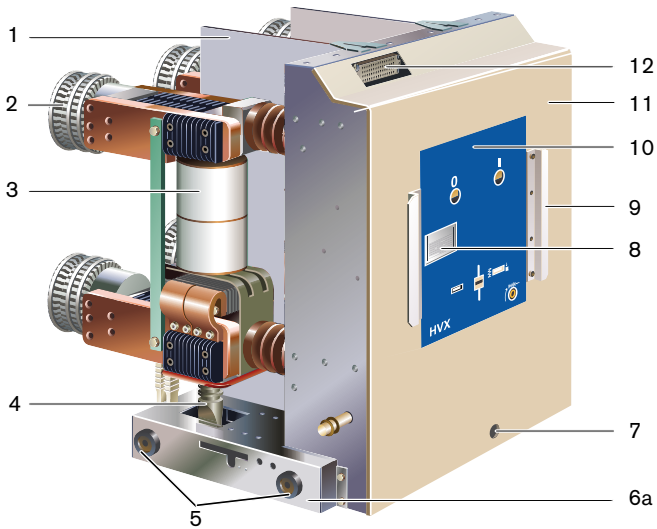

Rated voltage U_r	[kV]	≤ 17.5
Rated lightning impulse withstand voltage U_p	[kV]	95
Rated power frequency withstand voltage U_d	[kV]	38
Rated normal current I_r	[A]	≤ 3150 40001
Rated short-circuit breaking current I_{sc}	[kA]	≤ 50
Rated short-time current I_k (3 s)	[kA]	≤ 50
Rated frequency f_r	[Hz]	50/60
Weight (without packaging)	[kg]	approx. 330

1 with fan in PIX standard panel

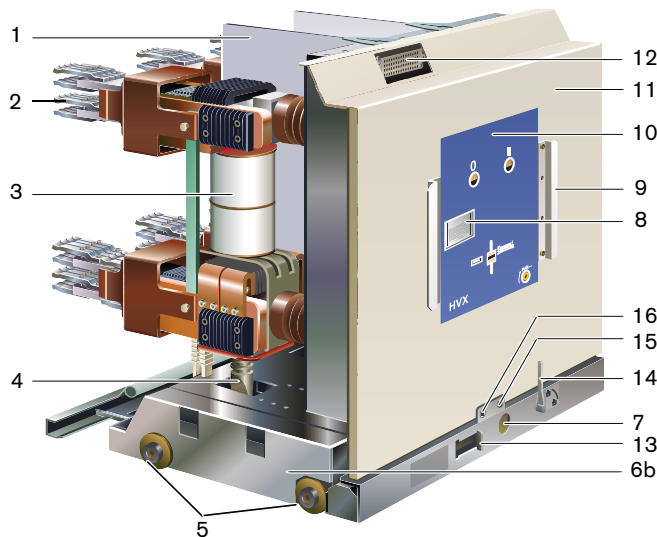

Rated voltage U_r	[kV]	≤ 17.5
Rated lightning impulse withstand voltage U_p	[kV]	95
Rated power frequency withstand voltage U_d	[kV]	38
Rated normal current I_r	[A]	≤ 3150 40002 50002
Rated short-circuit breaking current I_{sc}	[kA]	≤ 50
Rated short-time current I_k (3 s)	[kA]	≤ 50
Rated frequency f_r	[Hz]	50/60
Weight (without packaging)	[kg]	approx. 135

2 with fan in PIX High panel

Fig. 2
Models of the vacuum circuit-breaker HVX-E

- | | |
|--|--|
| 1 Pole partitions | 10 Operator interface |
| 2 Moving contacts | 11 Drive casing |
| 3 Vacuum interrupter chambers | 12 Low-voltage connector for control lines |
| 4 Press rod (transfer of ON/OFF switching movement) | 13 Slide for opening the insertion opening (7) for racking the truck in and out manually |
| 5 Transport rollers | 14 Lever for locking/unlocking the truck in the panel |
| 6a Truck für PIX panels | 15 Position indicator - truck in service position |
| 6b Truck für PIX High panels | 16 Position indicator - truck in disconnected position |
| 7 Insertion opening for crank to move the circuit-breaker into its disconnected/service position | |
| 8 Nameplate | |
| 9 Handles | |

2.2 Vacuum circuit-breaker HVX-F (fixed version)

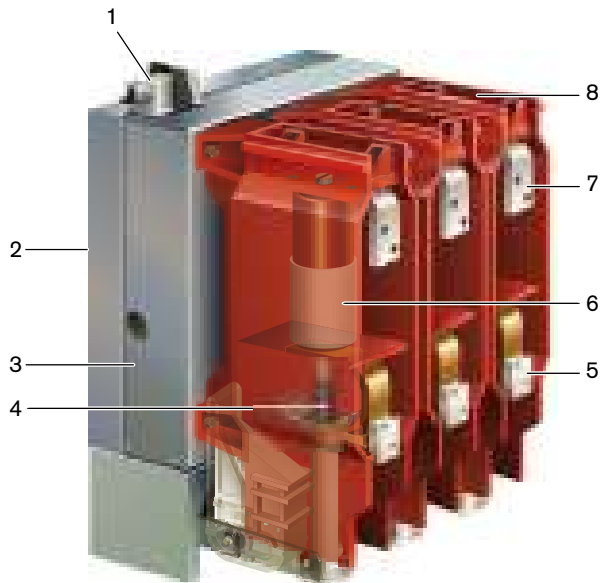

Rated voltage U_r	[kV]	≤ 12
Rated lightning impulse withstand voltage U_p	[kV]	75
Rated power frequency withstand voltage U_d	[kV]	28
Rated normal current I_r	[A]	≤ 1250
Rated short-circuit breaking current I_{sc}	[kA]	≤ 25
Rated short-time current I_k (3 s)	[kA]	≤ 25
Rated frequency f_r	[Hz]	50/60
Weight (without packaging)	[kg]	approx. 135

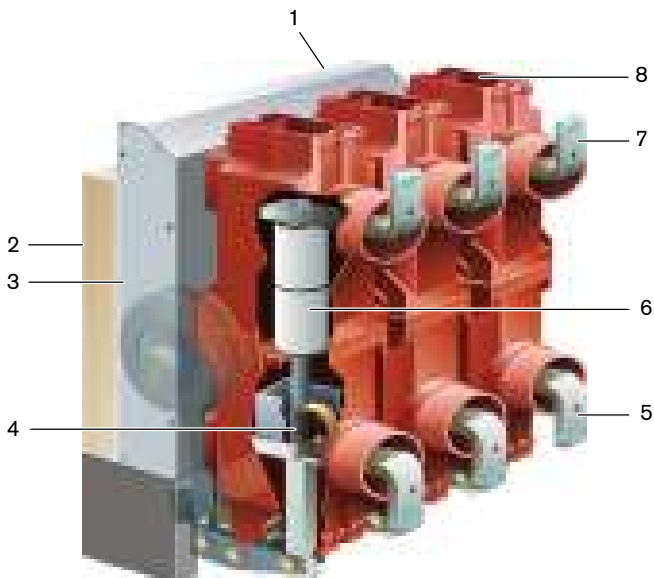

Rated voltage U_r	[kV]	≤ 24
Rated lightning impulse withstand voltage U_p	[kV]	125
Rated power frequency withstand voltage U_d	[kV]	50
Rated normal current I_r	[A]	≤ 2500
Rated short-circuit breaking current I_{sc}	[kA]	≤ 40
Rated short-time current I_k (3 s)	[kA]	≤ 40
Rated frequency f_r	[Hz]	50/60
Weight (without packaging)	[kg]	approx. 160

Fig. 3
Models of the vacuum circuit-breaker HVX-F

- | | | | |
|---|--|---|-----------------------------------|
| 1 | Low-voltage connector for control lines | 4 | Drive mechanism for pole sections |
| 2 | Front control panel (not visible in this illustration) | 5 | High-voltage connection, bottom |
| 3 | Drive casing | 6 | Vacuum interrupter chambers |
| | | 7 | High-voltage connection, top |
| | | 8 | Pole section |

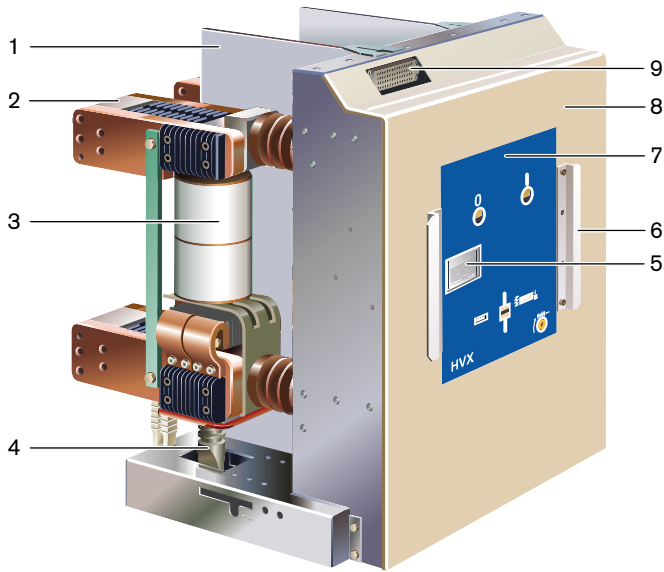

Rated voltage U_r	[kV]	≤ 17.5
Rated lightning impulse withstand voltage U_p	[kV]	95
Rated power frequency withstand voltage U_d	[kV]	38
Rated normal current I_r	[A]	3150 4000 ¹
Rated short-circuit breaking current I_{sc}	[kA]	≤ 50
Rated short-time current I_k (3 s)	[kA]	≤ 50
Rated frequency f_r	[Hz]	50/60
Weight (without packaging)	[kg]	approx. 230

¹ with fan (available on request from the manufacturer)

Fig. 4
Models of the vacuum circuit-breaker HVX-F

- 1 Pole partitions
- 2 Conductor bar terminal
- 3 Vacuum interrupter chambers
- 4 Press rod (transfer of ON/OFF switching movement)
- 5 Nameplate
- 6 Handles
- 7 Operator interface
- 8 Drive casing
- 9 Low-voltage connector for control lines

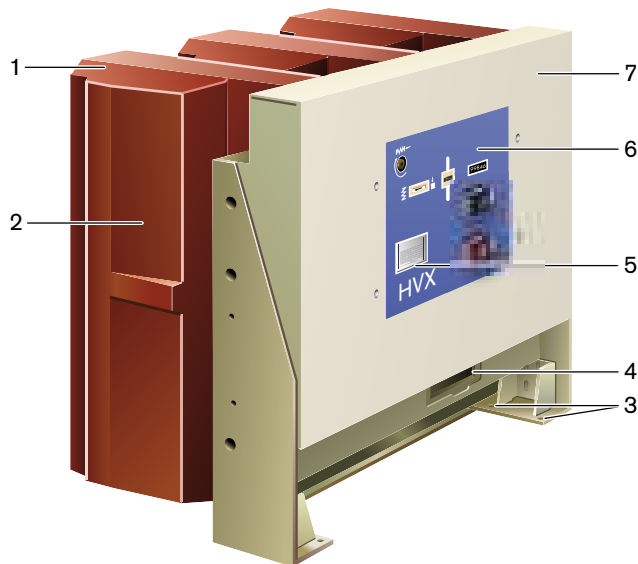

Rated voltage U_r	[kV]	36
Rated lightning impulse withstand voltage U_p	[kV]	170
Rated power frequency withstand voltage U_d	[kV]	70
Rated normal current I_r	[A]	≤ 2500
Rated short-circuit breaking current I_{sc}	[kA]	≤ 31.5
Rated short-time current I_k (3 s)	[kA]	≤ 31.5
Rated frequency f_r	[Hz]	50/60
Weight (without packaging)	[kg]	approx. 190

Fig. 5
Models of the vacuum circuit-breaker HVX-F

- 1 Circuit-breaker pole casing
- 2 Vacuum interrupter chambers (not visible in this illustration)
- 3 Fastening bore-holes
- 4 Low-voltage connector for control lines
- 5 Nameplate
- 6 Operator interface
- 7 Drive casing

2.3 Dimensions

The dimensions of the individual HVX variants are specified in the selection list HVX. This document or additional customized dimensional drawings are available on request.

2.4 Applied standards

Series HVX circuit-breakers are

- type-tested
- dimensioned for indoor installation

HVX series circuit-breakers meet the following standards and regulations:

Designation	IEC standard	EN standard
High-voltage switchgear and controlgear - Part 1: Common specifications	IEC 62271-1	EN 62271-1
Circuit-breaker	IEC 62271-100	EN 62271-100
Disconnecter truck	IEC 62271-102	EN 62271-102

Regarding the switching capacity and the insulation level, the series HVX complies with the following ANSI specifications¹:

- ANSI C37.04
- ANSI C37.06
- ANSI C37.09

¹ other standards available on request

Type approval of vacuum interrupter chambers acc. to RÖV

The vacuum interrupter chambers have been approved by the X-Ray Ordinance (RöV) of the Federal Republic of Germany up to a maximum voltage amounting to the rated short-time power-frequency voltage (rated power frequency withstand voltage) defined by DIN VDE/IEC. Thus, they satisfy the conditions for operation exempt of approval up to the voltage in question according to the X-Ray Ordinance (RöV).

2.5 Environmental and operating conditions

HVX circuit-breakers may only be operated under normal operating conditions acc. to IEC 62271-1. Operation under conditions deviating from these is only admissible upon consultation with and with the written approval of the manufacturer.

(Ambient conditions in accordance with IEC 62271-1)		
Temperature class		"Minus 5 indoors" ¹
Min./max. ambient temperature	°C	-5/+40 ¹
Average value over 24 hours	°C	≤ 35 ¹
mean rel. air humidity: 24 hour/1 month	%	≤ 95/≤ 90
Installation altitude above sea-level	m	≤ 1000 ¹

¹ other values available on request

2.6 Nameplate

The type designation on the nameplate (Fig. 6) specifies essential technical data.

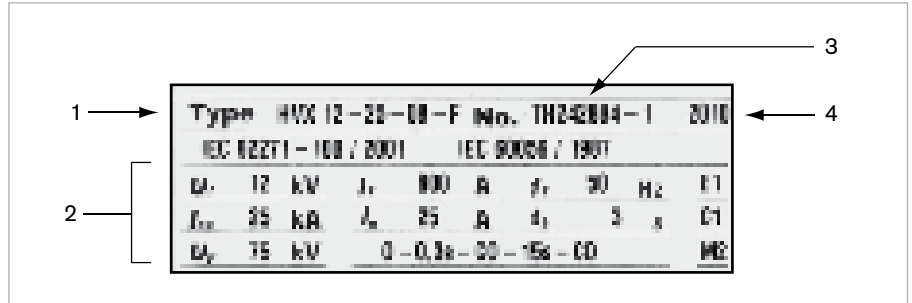
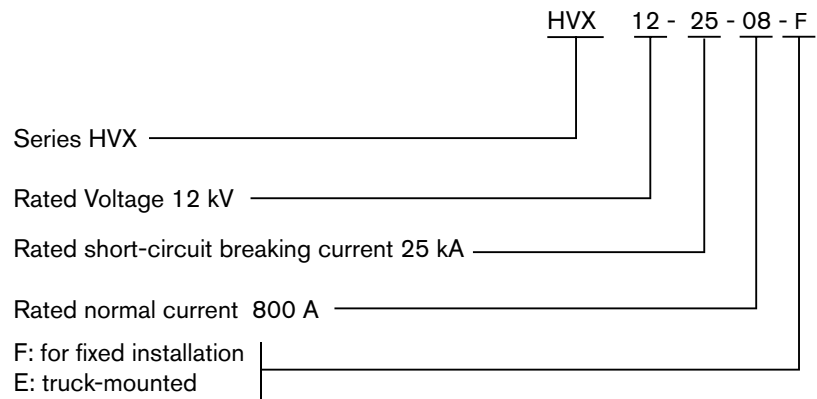

Fig. 6

Nameplate

- 1 Type designation
- 2 Technical data
- 3 Serial number
- 4 Year of construction

The following example shows the composition of the type designation:



When submitting enquiries to the manufacturer or ordering spare parts, the following information is required:

- Type designation
- Serial number
- Year of construction

2.7 Technical data of electrical control and operating devices

The circuit-breaker (Q0) and the truck versions (Q1) have been designed on principle for manual operation. The drive mechanisms can be equipped, depending on the specific customer's model, with additional electrical control and operating devices. These are defined in the switch-specific circuit diagram (see separate documentation).

Component fitting options:

- Motor (M1)
 - for charging the energy-storing device
 - HVX-E: electric actuation of the disconnecter truck
- Shunt closing release (F2)
 - 1 pce.
- Shunt tripping coil (F11/F12/F13)
 - 3 ea. max.
- Secondary release (transformer-operated release) (F31/F32/F33)
 - 3 ea. max.
- Undervoltage release (F4)
 - 1 pce.
- Blocking coil (Y1)
 - Blocking coils prevent the circuit breaker from being closed and opened via the push-buttons “ON” or “OFF”, as well as manual actuation of the disconnecter truck.
 - If the rated supply voltage has failed or is shut off, all blocking coils are in "blocked" position.
- Auxiliary switch for circuit-breaker ON/OFF position (S11/S12/S13)
 - Auxiliary switches are always actuated directly by the switch shaft via an intermediate linkage. Their position always corresponds to that of the main contacts. As standard, the circuit-breaker is equipped with two (optionally three) auxiliary switches, each one with 8 contact elements.
 - The switching functions have been set in the factory according to the wiring diagram.
- Micro switch actuated by energy-storing device (S2)
- Micro switch actuated by ON/OFF push-button (S41/42)
- Micro switch actuated by OFF pushbutton (S43)
- Micro switch actuated by truck in intermediate position or by crank being inserted (S6)

The circuit-breaker (Q0) and the truck versions (Q1) can be equipped with additional micro switches, depending on customers' design.
- Anti-pumping relay (K01)
 - If an ON and OFF command is simultaneously and permanently present at the circuit-breaker, the latter returns to its initial position after closing. It remains in this initial position until the ON command is issued again. This prevents continuous closing and opening (“pumping”).
- Terminal strip (X01)

Overview of rated supply voltages

Overview of rated supply voltages							
Direct voltage DC	[V]	24	48	60	110	125	220
Alternating voltage AC	[V]	(110)/120			(220)/230		

Technical data of the electrical releases and motors

Solenoids / motor	Power consumption [W]	
	DC [W]/AC 50/60 Hz [VA]	
Rated normal current [A]	≤2500	>2500
Closing release	≤ 250	
Opening release	≤ 250	
Undervoltage release	approx. 12	
Motor for energy-storing device	approx. 100	approx. 150
Motor for disconnecter truck	approx. 120	<200
Secondary release	approx. 12 (AC)	

Information about the power consumption of solenoids and the motor is available from the manufacturer. The supply voltage data is required to this effect.

Times for solenoids and motor		
Minimum command time "OFF" el. tripping	[ms]	20
Minimum command time "ON" el. tripping	[ms]	20
Motor charging time for energy storing device	[s]	≤ 12

Technical data of the auxiliary switches on the circuit-breaker

Rated supply voltage	[V]	DC [V]			AC [V]	
		≤ 48	125	220	120	230
Switching capacity	[A]	10	3.8	2	10	
Rated short-time current		250 A / 3 s				
Time constant T = L/R	[ms]	10	20	-		
Rated continuous current	[A]	15			-	

Technical data of auxiliary switches on the disconnecter truck for PIX High panels

Rated supply voltage	[V]	DC [V]					AC [V]	
		24	48	60	110	220	120	230
Switching capacity	[A]	8	4	3	2	1	10	
Rated short-time current		100 A/30 ms						
Time constant T = L/R	[ms]	≤ 20						
Rated continuous current	[A]	10						

Liability Disclaimers

2.8 Intended use

Series HVX vacuum circuit-breakers are exclusively intended as switching units in air-insulating medium-voltage switchgear. They may only be used in the scope of the specified standards and the switchgear-specific technical data. Any other utilization constitutes improper use and may result in dangers and damage.

The manufacturer shall not be held responsible for damage which occurs if

- instructions in this manual are not complied with,
- the circuit-breaker is not operated according to its intended use (Chapter 2.8)
- the circuit-breaker is assembled, connected or operated improperly,
- accessories or spare parts are used which have not been approved by the manufacturer,
- the circuit-breaker is converted without the manufacturer's approval, or if inadmissible parts are attached.

2.9 Disposal after the end of service life

A material and recycling data sheet is available for disposal of the vacuum circuit-breaker unit at the end of its service life; this can be provided on request.

Disposal is performed by the manufacturer's Service Center as a service subject to a fee.

Packaging

3.1 Shipping units

- The conditions and types of transport have been stipulated in the contract details. The type of packaging depends on the type of transport and the storage conditions.
- The circuit-breakers are delivered ready for connection. The accessories are included.
- If packed exclusively for truck transport, the circuit-breakers are delivered, depending on their outside dimensions, either
 - in cardboard boxes and delivered on a pallet (Fig. 7),
 - directly fixed to the pallet and packed in PE protective film,
 - fastened to the pallet using steel beams for transport and packed in PE protective film (only 36 kV version) (Fig. 8) or
 - delivered in wooden crates with PE protective film (Fig. 9).
- For sea transport, the units are packed in sealed aluminium foil with desiccant and in a closed wooden case with tightly closed wooden base (also for container transport).
- In case of air transport, the panels are packaged in wooden crates with a protective PE film hood (dust protection) or in wooden crates, also with closed wooden bases, however without protective hoods (dust protection, Fig. 9).



Important:

The weight of the entire transport unit is indicated on the packaging.

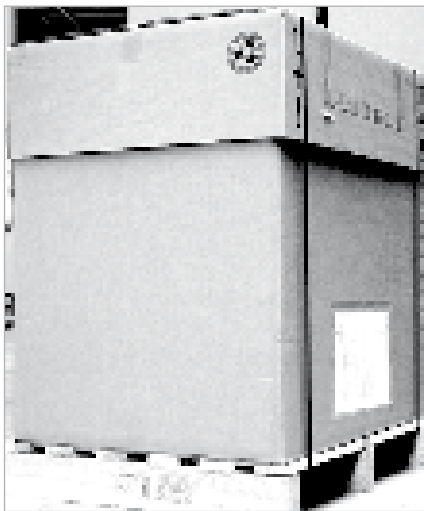

Fig. 7
Packed in cardboard box on a pallet

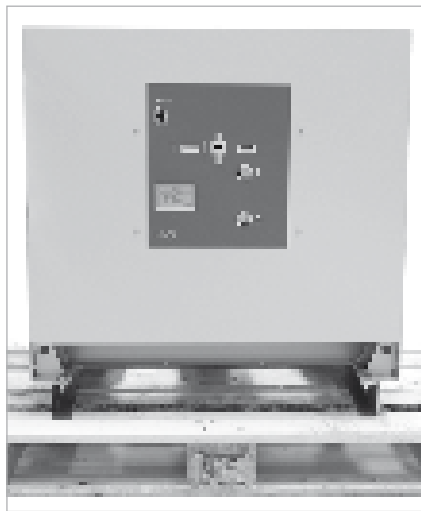

Fig. 8
Fastened to pallet by means of steel beams

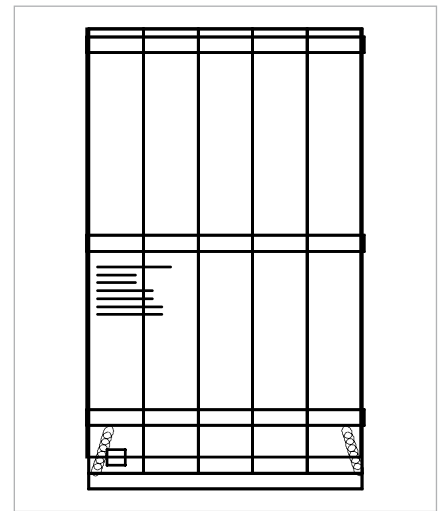

Fig. 9
Packed in a wooden case

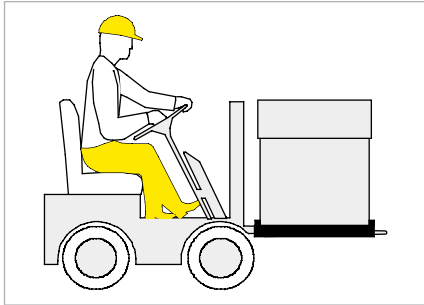

Fig. 10
Transport using a forklift truck

3.2 Transport

- Transport using a forklift truck:

Move packing unit only complete with pallet. Move the forks completely under the whole pallet. The circuit-breaker must be fixed safely on the pallet.

3.3 Delivery

- Handle shipping units carefully when unloading and unpacking them.
- Shipping units must be checked upon receipt. Any damage which may have occurred in transit must be recorded and reported to the manufacturer immediately.
- Check completeness of consignment based on the transport documents. The supplier must be notified in writing without delay about any possible deviations.

3.4 Storage



Warning!

Risk of injury due to sliding or tilting of transport units. Sufficient stability and evenness of the supporting area (floor) must be ensured.

The transport packaging is not intended for storage.

If the circuit-breakers are not put into operation immediately after delivery, they can be stored under the following conditions:

- only indoors
- Circuit-breakers must be packed in a wooden crate with a dessicant and sealed in aluminium foil (storage period max. 2 years after date of packaging).

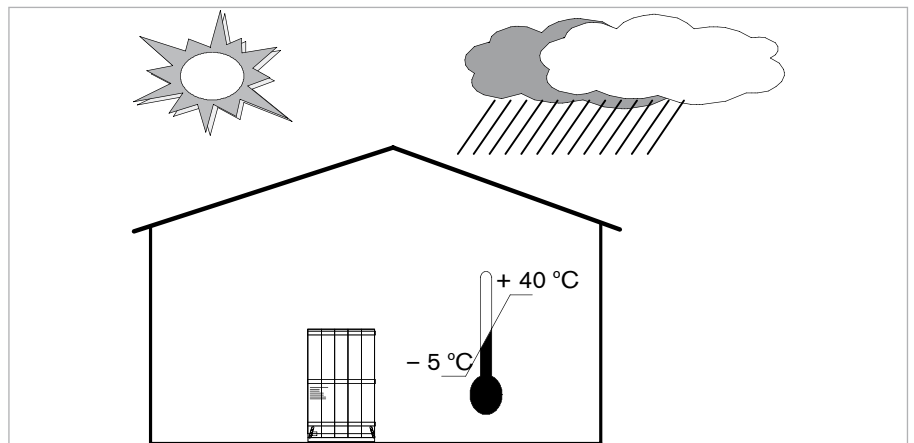

Fig. 11
Schematic diagram of the storage conditions for HVX circuit-breakers

4.1 Safety provisions and instructions for assembly



Warning!
Risk of injury. Please comply with the safety provisions in Chapter 1, page 5.



Warning!
Risk of injury due to movable parts in mechanical drives. Do not charge the circuit-breaker's energy-storing device during assembly.

The circuit-breakers may only be assembled and installed by the manufacturer's staff or by persons who have been certified for this work.

The circuit-breakers are delivered in circuit-breaker position "OFF" and with the energy storing device "released".

Instructions for assembly

- For all screw connections which are not specified directly in the assembly description, the tightening torques mentioned in Chapter 8.3 on page 48 must be used.
- Check technical data on nameplate.
- Dimension drawings are provided on request.
- Any other than standard installation positions must be agreed upon with the manufacturer.
- Screws, bolts and attachments are not included in the scope of supplies.
- Parts designed for fastening must be suitable for the weight of the circuit-breaker.
- The circuit-breaker must not be deformed by the fastening.

4.2 Transport using a crane



Warning!
Risk of injury during crane transport. Comply with the relevant provisions for hoisting equipment. Make sure the crane mounting harness is sufficiently strong.

For crane transport, a crane mounting harness with a rope (not a metallic steel cable) with a diameter of \varnothing 12–15 mm or a strap is used. The specified weight must be complied with.

HVX model designed for
 $U_r \leq 24$ kV
 $I_r \leq 2500$ A
 $I_{sc} \leq 40$ kA

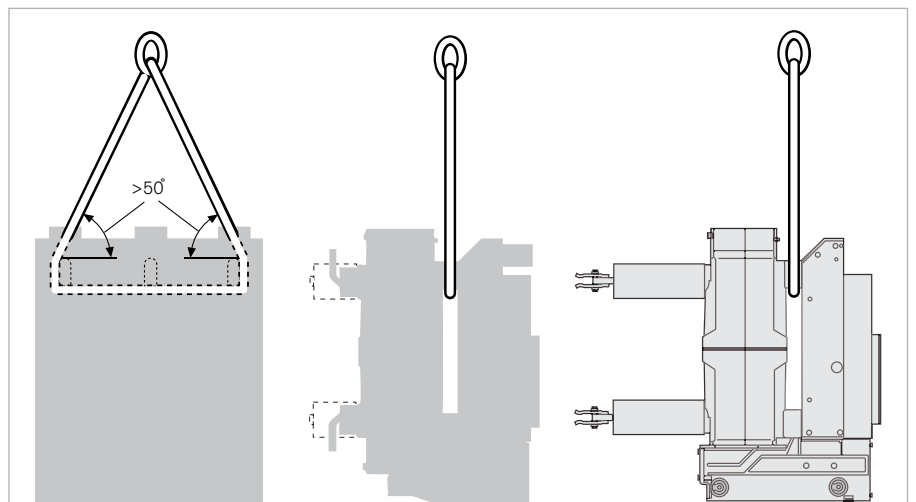

Fig. 12
Transport by means of a crane

HVX model designed for
 $U_r \leq 17.5 \text{ kV}$
 $I_r \leq 3150 \text{ A}$
 $I_{sc} \leq 50 \text{ kA}$



Important:
 Position circuit-breaker with guide rollers on the truck on wooden bars or rails in order not to damage the guide rollers (Fig. 13).

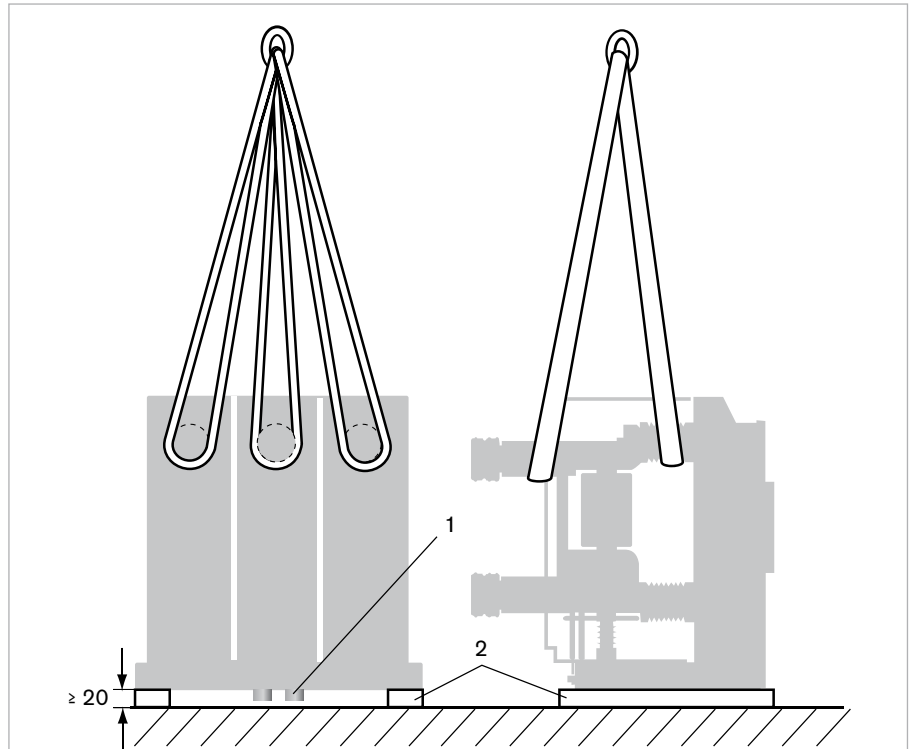

Fig. 13

Transport by means of a crane

- 1 Guide rollers (only on truck with pole center spacing 254)
- 2 Wooden bars or rails as a support

HVX model with
 $U_r = 36 \text{ kV}$

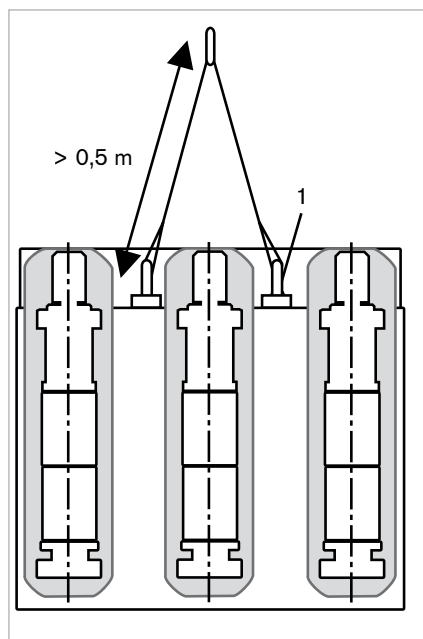

Fig. 14

Transport by means of a crane

- 1 Eye bolts



Fig. 15

Release screw connection for transport

Remove the transport support

4.3 Mechanical assembly of the fixed version HVX-F

The circuit-breakers shown below are protected against overturning by a transport support (U section rail on the central circuit-breaker pole) (Fig. 16). Unscrew transport support after or - if required - during assembly.

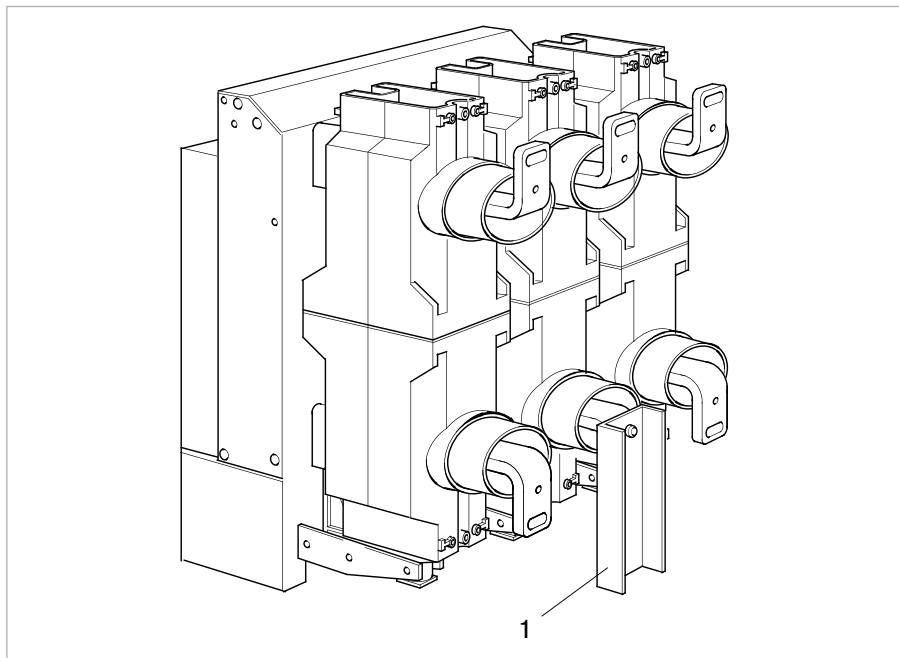

Fig. 16

1 Transport support

4 Assembly

For fastening, the circuit-breaker HVX-F features 4 bore-holes with a \varnothing of 12.5 mm. Fasten the circuit-breaker to the frame below the drive casing using 4 screws M 10 (Fig. 17).

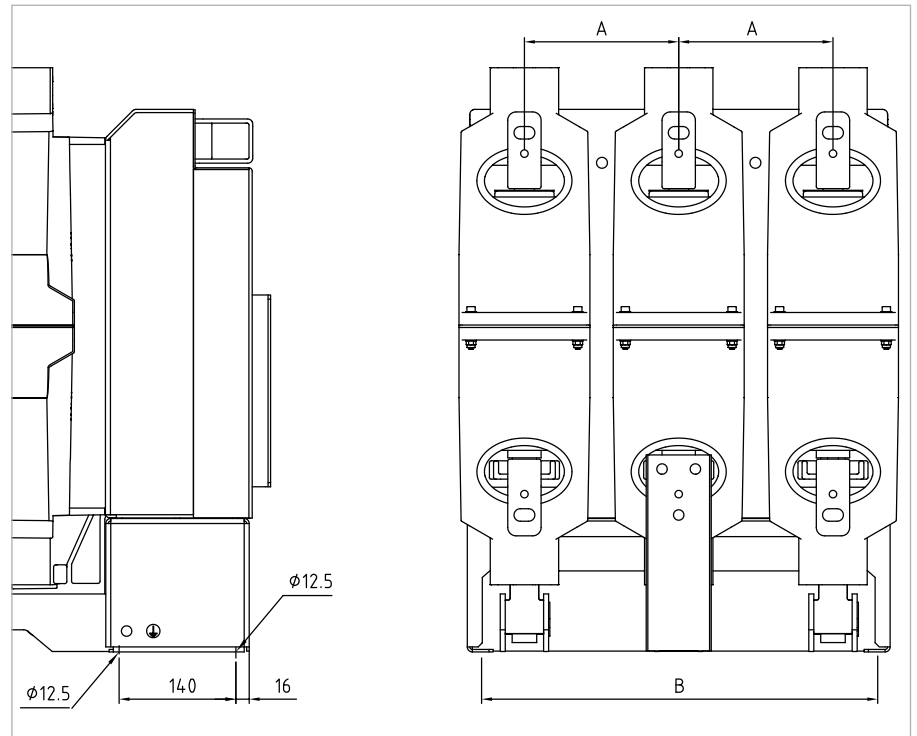

Fig. 17
Dimension drawing of the fastening points on circuit-breakers HVX-F for rated normal current $I_r \leq 2500$ A

Version HVX-F		Pole center distance A [mm]	Distance between fastening bore-holes B [mm]
Model designed for $U_r \leq 12$ kV $I_r \leq 1250$ A $I_{SC} \leq 25$ kA		150	408
		210	534
Model designed for $U_r \leq 24$ kV $I_r \leq 2500$ A $I_{SC} \leq 40$ kA		165	471
		185	471
		210	534
		275	664

Fastening the circuit-breaker HVX-F dimensioned for $I_r \leq 3150$ A, $I_{sc} \leq 50$ kA

The circuit-breaker cannot be fastened using an L rail (not included in scope of supplies) (Fig. 18). Fastening points are the lateral bore-holes ($\varnothing 13$) in the lower circuit-breaker housing. A dimensional drawing is provided on request. Please clarify further technical details with the manufacturer.

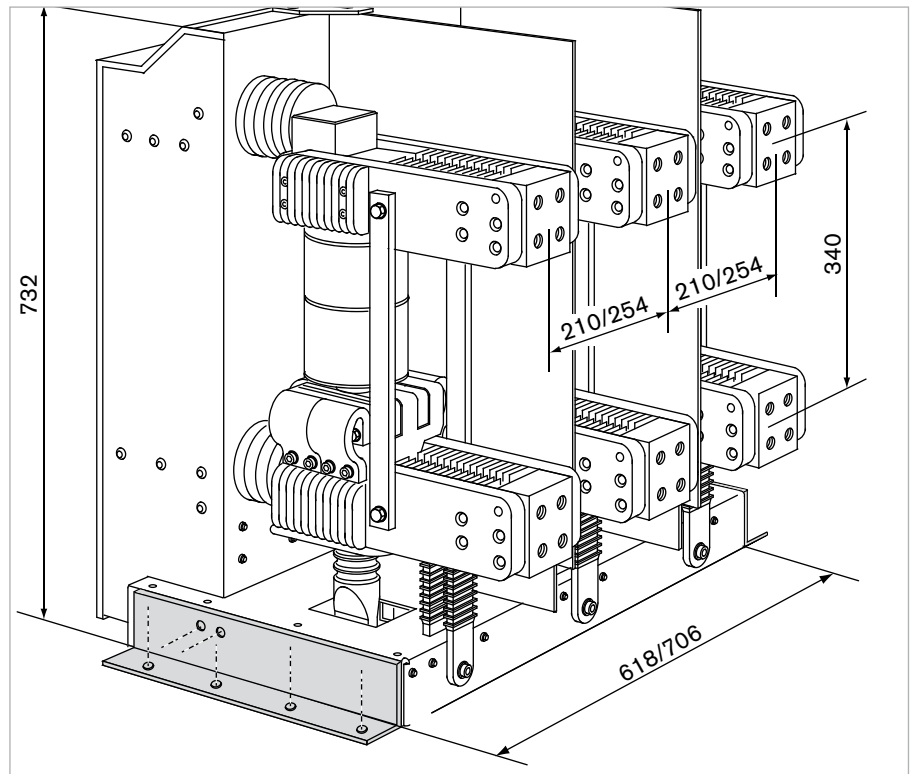

Fig. 18
Dimensions and fastening points of the circuit-breaker HVX-F with $I_r \leq 3150$ A, $I_{sc} \leq 50$ kA

Fastening the circuit-breaker HVX-F dimensioned for $U_r = 36$ kV

4 bore-holes for fastening are provided in the base plate of the rack for M12 screw connections.

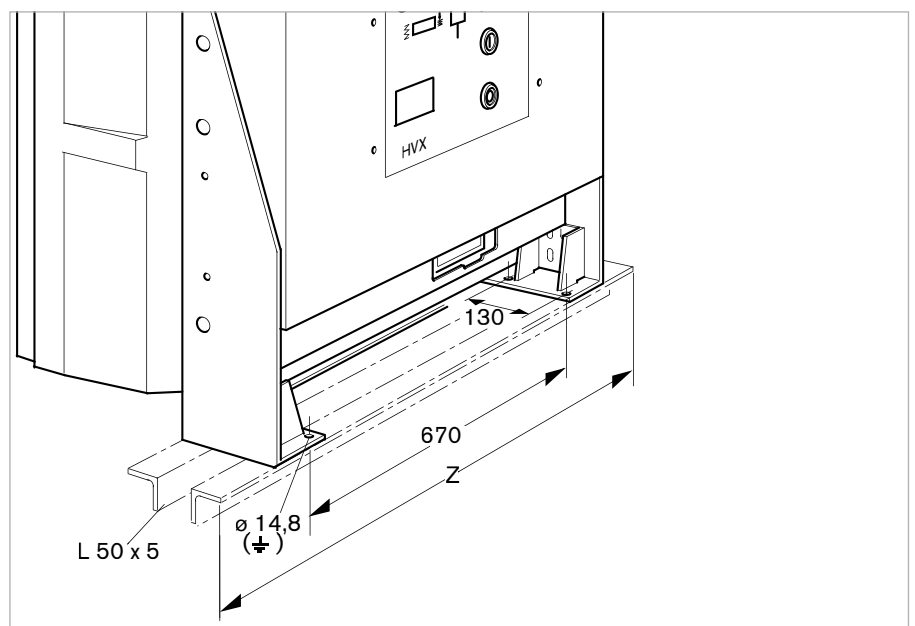

Fig. 19
Fastening, earth terminal
Z Panel width
L Recommended dimensions

4.4 Earth terminal

**Important:**

Treat contact surfaces and comply with specified tightening torques (see Chapter 8 as of page 47).

Earthing devices are not included in the scope of supplies.

Design and dimensioning of the earth terminal for the circuit-breaker in accordance with

- IEC 62271-100 and
- national design specification (Germany: DIN VDE 0101)

The mechanical fastening of the circuit-breaker (see Chapter 4.3 as of page 19) is simultaneously used to earth the circuit-breaker.

Additional earth connection

Additionally, both sides of the rack of the smaller fixed-type versions feature bore-holes \varnothing 12.5 mm for a further earth terminal (Fig. 20).

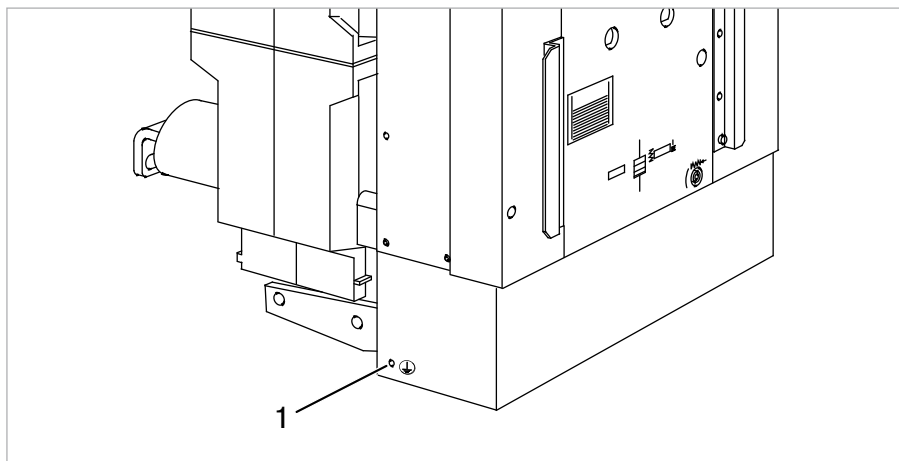

Fig. 20

- 1 Earth terminal \varnothing 12.5 (on both sides) on circuit-breakers HVX-F with rated normal current $I_r \leq 2500$ A

4.5 Connecting conductor bars



Warning!

Danger due to contact corrosion in case of inadmissible matching of materials! Aluminium conductor bars must not be connected to the connection areas of the circuit-breaker.



Important:

- Treat contact surfaces and comply with specified tightening torques (see Chapter 8 as of page 47).
- The circuit-breaker must not be deformed in the process of connection.

Material of connection surfaces

Rated normal current I_r	Connection areas	
	on circuit-breaker	on the conductor bar
630 A	Copper, metallicly bright	Copper
> 630 A	Copper, silver-plated	Copper or copper, silver-plated

Note for connection of the conductor bars or cables:

- Adjust conductor bars so that after screw-fastening, no mechanical forces are acting on the circuit-breaker.
- Conductor bars must be dimensioned sufficiently according to the specifications for rated and short-circuit current. National standards must be complied with.
- In case of short-circuit current, make sure that the circuit-breaker pole is not exposed to higher electrodynamic forces. The connecting bars must be provided with sufficient support in the vicinity of the circuit-breaker connectors.

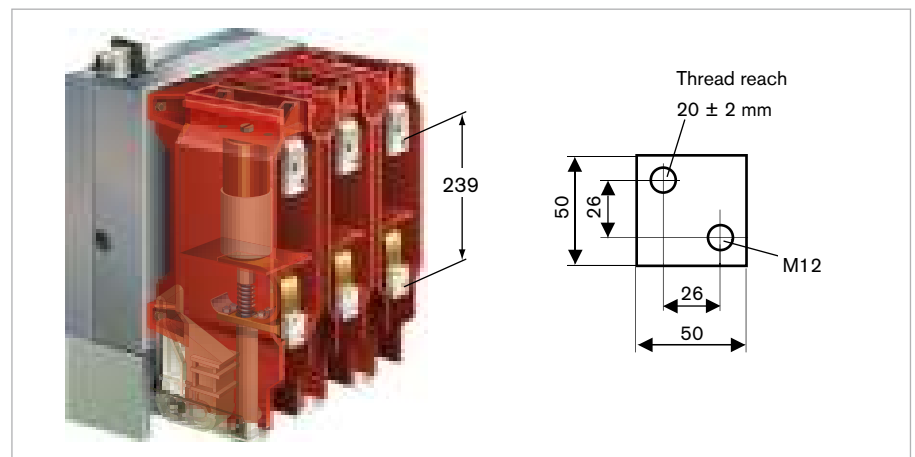

Fig. 21
High-voltage terminal of circuit-breaker HVX-F ($U_r \leq 12$ kV, $I_r = 1250$ A, $I_{sc} \leq 25$ kA)

4 Assembly

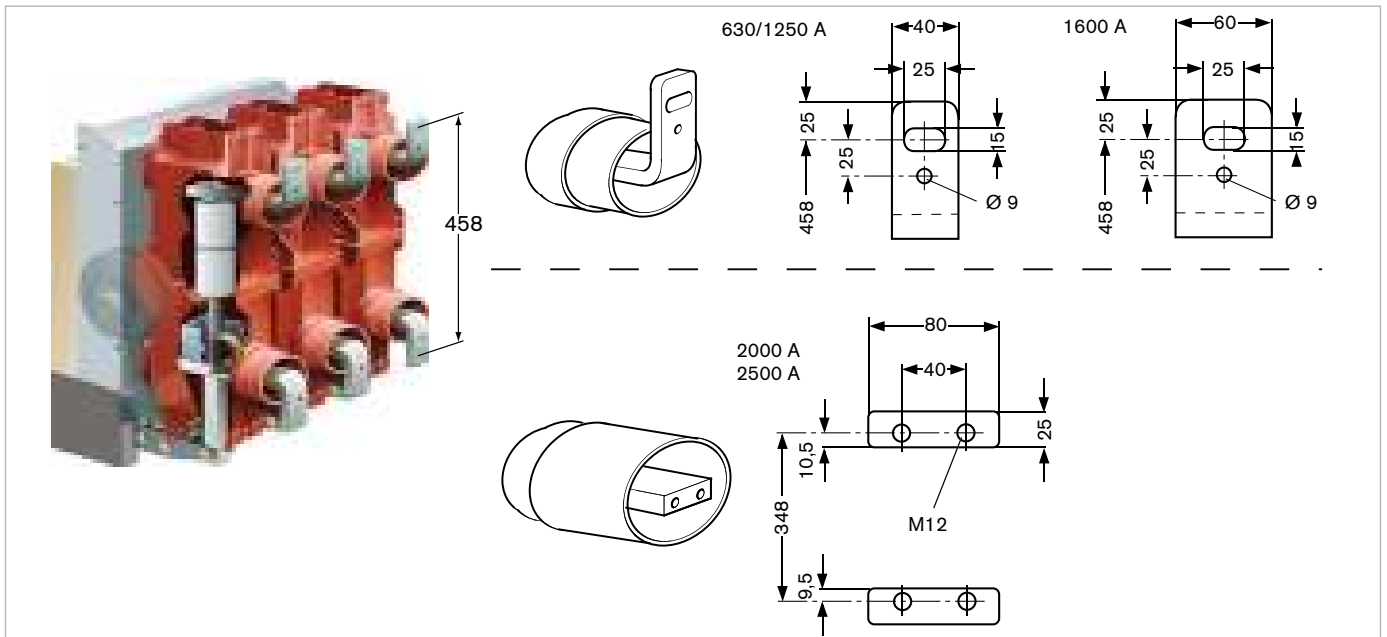

Fig. 22
High-voltage terminal for fixed mounting HVX-F ($U_r \leq 24$ kV, $I_r \leq 2500$ A, $I_{sc} \leq 40$ kA)

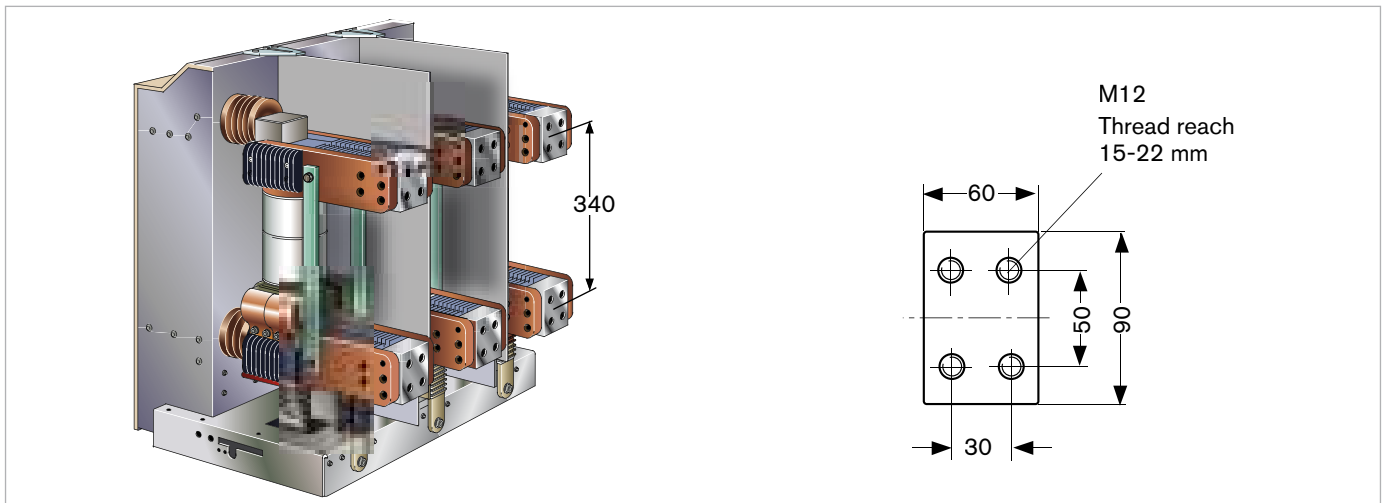

Fig. 23
High-voltage terminal of circuit-breaker HVX-F ($U_r \leq 17.5$ kV, $I_r \leq 3150$ A, $I_{sc} \leq 50$ kA)

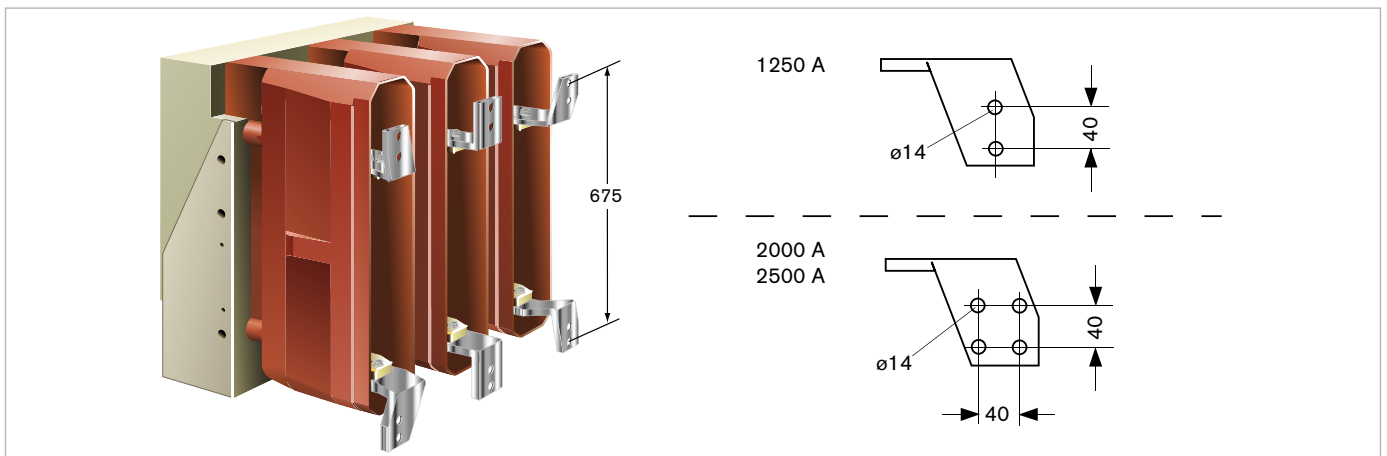

Fig. 24
High-voltage terminal of circuit-breaker HVX-F ($U_r = 36$ kV, $I_r \leq 2500$ A, $I_{sc} \leq 31.5$ kA)

4.6 Mounting the circuit-breaker HVX-E (truck-type)

A transport trolley must be used for racking the circuit-breaker into the panel (Fig. 25 and Fig. 26). The transport trolley depends on the panel type and is not included in the scope of supplies. For the design and method of operation of the transport trolley used, please refer to the instructions for the panel in question.

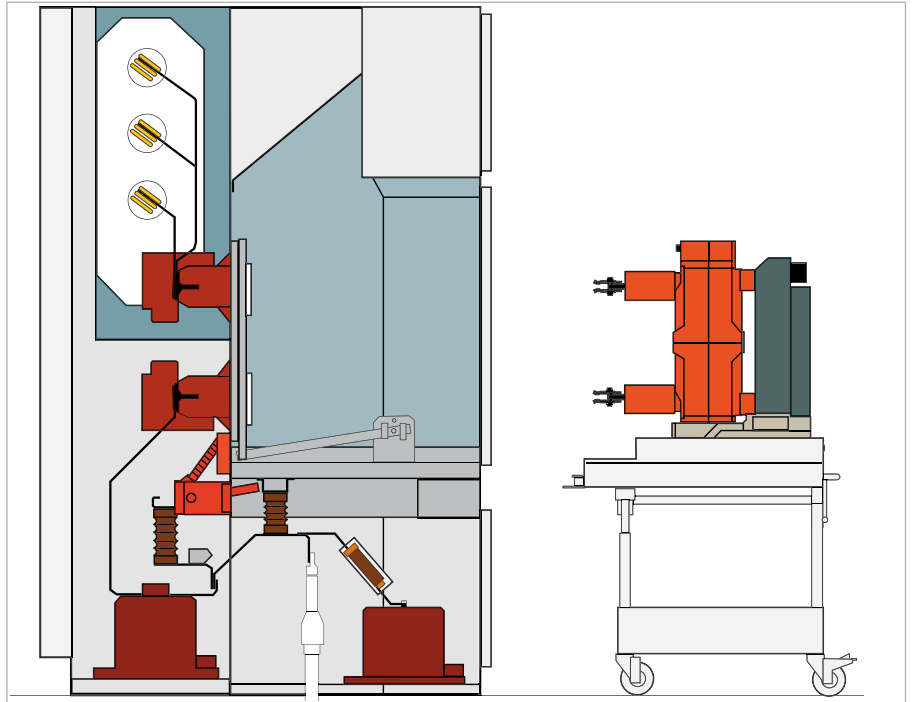

Fig. 25
Circuit-breaker HVX-E (≤ 40 kA) on transport trolley in front of the panel PIX Standard

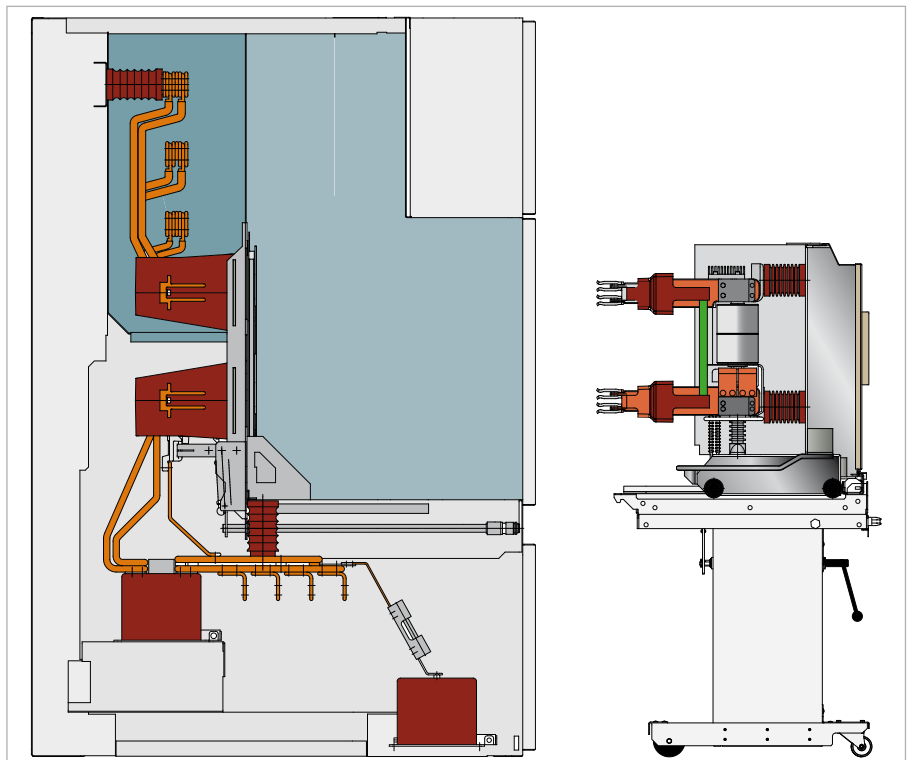

Fig. 26
Circuit-breaker HVX-E (50 kA) on transport trolley in front of the panel PIX High

Placing circuit-breaker on transport trolley and racking it into the switchgear



Important:

- When performing the following assembly steps, observe and comply with the instructions given for the panel used.
- Optionally, HVX trucks and panels may be coded to match (Fig. 27). This is to prevent a truck from being racked completely into the panel if the ratings do not match.

1. Check the ratings indicated on the nameplate of the HVX-E against those of the appropriate panel.
2. Place the circuit-breaker on the transport trolley rails.
3. Lock the circuit-breaker on the transport trolley.
4. Couple the transport trolley to the panel.
5. Unlock the circuit-breaker from the transport trolley. Push the circuit-breaker into the panel.
 - The HVX trucks must latch in the lock rockers of the panels (Fig. 27).
 - HVX trucks for PIX High Panels are anchored in the panel by actuation of the truck interlock (Fig. 28).
6. Release the transport trolley from the panel.

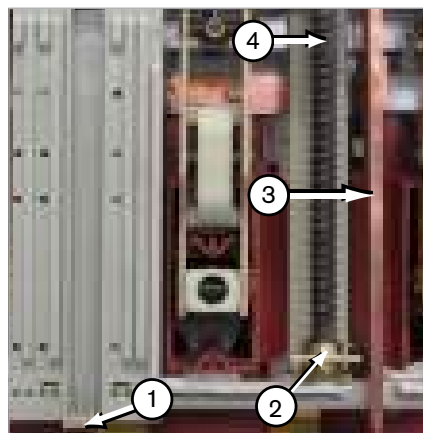

Fig. 27

HVX-E underside

- 1 Circuit-breaker coding
- 2 Spindle nut of truck (must be latched in the cell)
- 3 Earth bar (optional)
- 4 Spindle of disconnecter truck

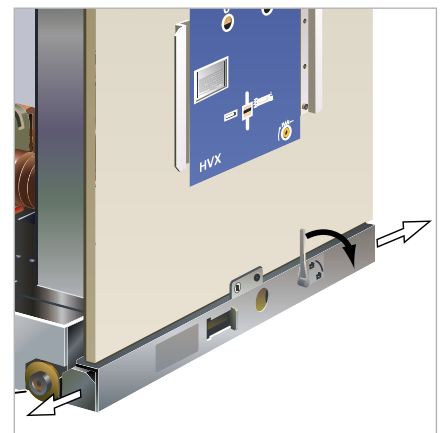

Fig. 28

Truck interlock in PIX High panel

Earth terminal

The equipotential bonding connection of the circuit-breaker and the panel is effected via the two front truck rollers (Fig. 29). The HVX-E circuit-breaker is optionally available with short-circuit proof earthing (Fig. 27 item 3 and Fig. 30).

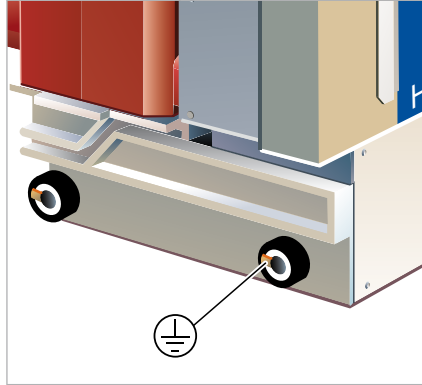

Fig. 29
Equipotential bonding in the cell above the truck rollers

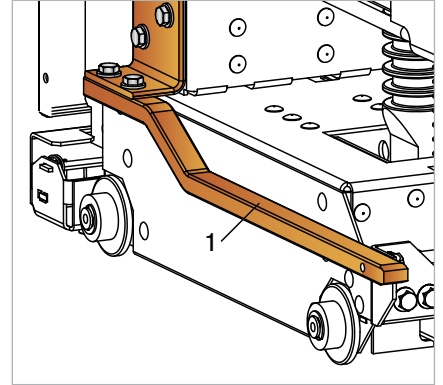

Fig. 30
1 Earth bar on circuit-breaker HVX-E for PIX High panels

4.7 Connecting the control lines

The control lines are connected, depending on design, via control connectors (Fig. 31, Fig. 32, Fig. 33 and Fig. 35 on page 28) or via control lines to the terminal strips in the drive casing (Fig. 34 and Fig. 36 on page 28). The control lines are wired in the circuit-breaker up to the control connector or up to the terminal strip.

Single-wire conductors or strands can be connected

- on terminal strip, up to 2.5 mm²
- in the control connector, up to 1.5 mm².

Connection via control connector

Push the control connector onto the 64-(36-) pin right-angle plug-and-socket connector of the circuit-breaker, and lock it (Fig. 31, Fig. 32, Fig. 33 and Fig. 35 on page 28).

**Important:**

Connector interlock of HVX-E: The control connector on the cell end can only be inserted or removed while the circuit-breaker is in disconnected position.

Connection to terminal strip

1. Remove the cover plate.
2. Connect external control lines via the terminal strip (Fig. 34 and Fig. 36 on page 28). The switch-specific circuit diagram (electric diagram) is enclosed with each circuit-breaker and must be observed during connection. If additional control lines are laid in the drive casing, keep a sufficient distance from moved parts of the drive.
3. After connecting the external control lines, mount the cover plate.

4 Assembly

**HVX dimensioned for
 $U_r = 12-24 \text{ kV}$**

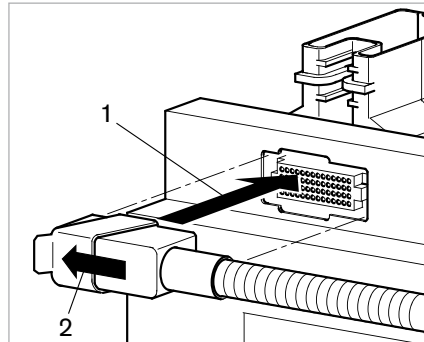

Fig. 31
Control connector, 64-pole
1 Insert control connector
2 Lock

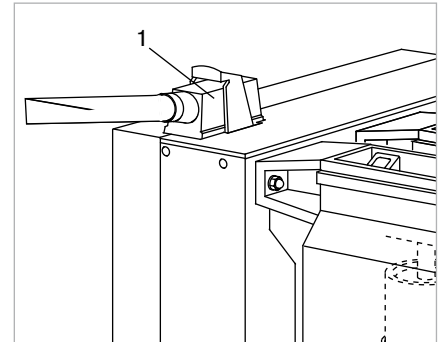

Fig. 32
1 Control connector, 64-pole

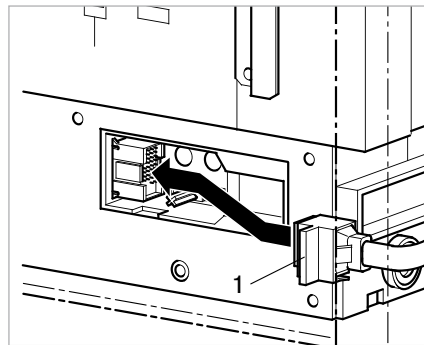

Fig. 33
1 Insert control connector, 36-pole

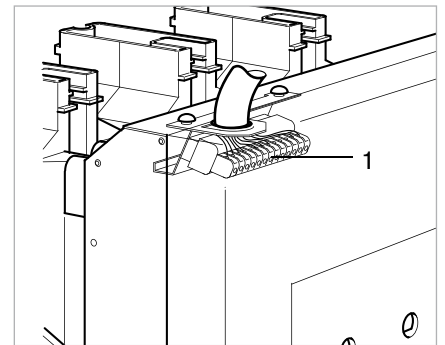

Fig. 34
1 Control line connector on terminal strip

**HVX dimensioned for
 $U_r = 36 \text{ kV}$**

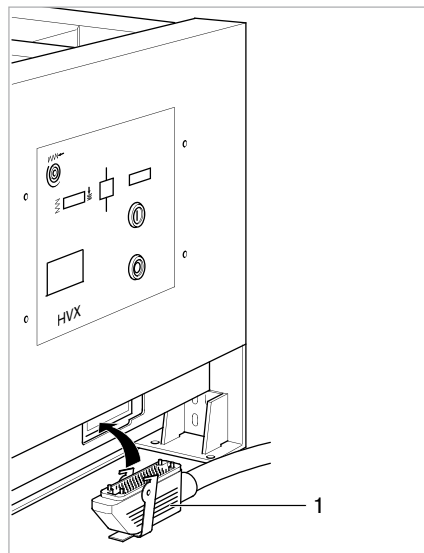

Fig. 35
1 Insert control connector, 64-pole

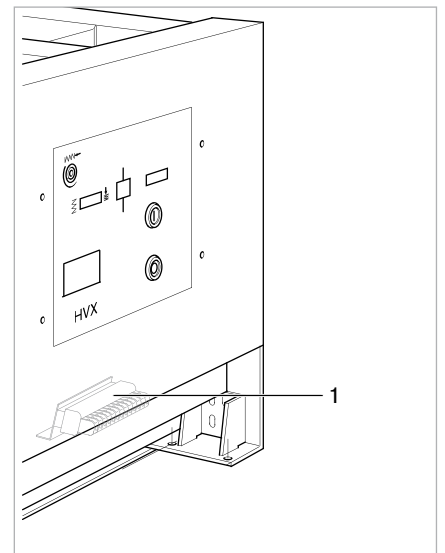

Fig. 36
1 Control line connector on terminal strip

5.1 Final steps



Danger!
Risk of fatalities due to high voltage. All active parts must be earthed.

Checking assembly

- Check securing bolts.
- Check the conductor bars' screw connections using a torque wrench.
- Check the screw connections of the earth terminal.
- Check wiring laid on site.

Damaged paint

Minor damage to the paint can be repaired using a commercially available touch-up pen (standard colour RAL 7044 or corresponding colour) (see Chapter 8.1 "Auxiliary products" on page 47).

Inspection

- Check the circuit-breaker for damage which might be due to transport or assembly work.
- Compare the data on the nameplate (see Chapter 2.6 on page 11) to the required rating specifications.
- Check rated supply voltage of control and operating devices.
- Check surfaces of insulating components for impurities. If necessary, clean (see Chapter 7.3 on page 41).

5.2 Checking switching functions and interlocks



Danger!
The high-voltage supply must not be connected. All active parts must be earthed.

**Important:**

- For switching operations, comply with Chapter 6 "Operation" as of page 31.
- In case supply voltage is not available,
 - blocking coils (optional; lock circuit-breaker button and/or truck in disconnected position) are in locked position, thus blocking manual switching operations;
 - there is a dropped-out undervoltage release in the circuit-breaker (optional).
- The energy-storing device of the circuit-breaker drive is charged autonomously as soon as the supply voltage is applied.

Checking switching functions and interlocks:

1. Charge energy-storing device using the crank. Check position indicator on the circuit-breaker.
2. Apply supply voltage.
3. Switch circuit-breaker on and off several times manually. Check position indicator.
4. Move truck to its operating and disconnected positions via the crank (only HVX-E). Check mechanical interlocks between the HVX-E and the cell. Check position indication.
5. Check electrical functions of control and operating devices:
 - Closing and opening releases for circuit-breaker
 - Optional motor-operated drives for the truck (only HVX-E)
6. Check switch position indicators and interlocks (Chapter 6 as of page 31).

Verification of the required ratings and performance characteristics**5.3 Checks for the circuit-breaker HVX in conjunction with panels/switching cells**

Before commissioning, panels or switching cells must be qualified completely with the switching devices installed by means of type tests in acc. with IEC 62271-200/ IEC 62271-1 or national regulations.

If the circuit-breaker HVX is used in panels or switching cells which have not yet been qualified together, type tests in acc. with IEC 62271-200 and IEC 62271-1 or national regulations must be performed.

For further information, please contact the manufacturer.

6.1 Operator interface

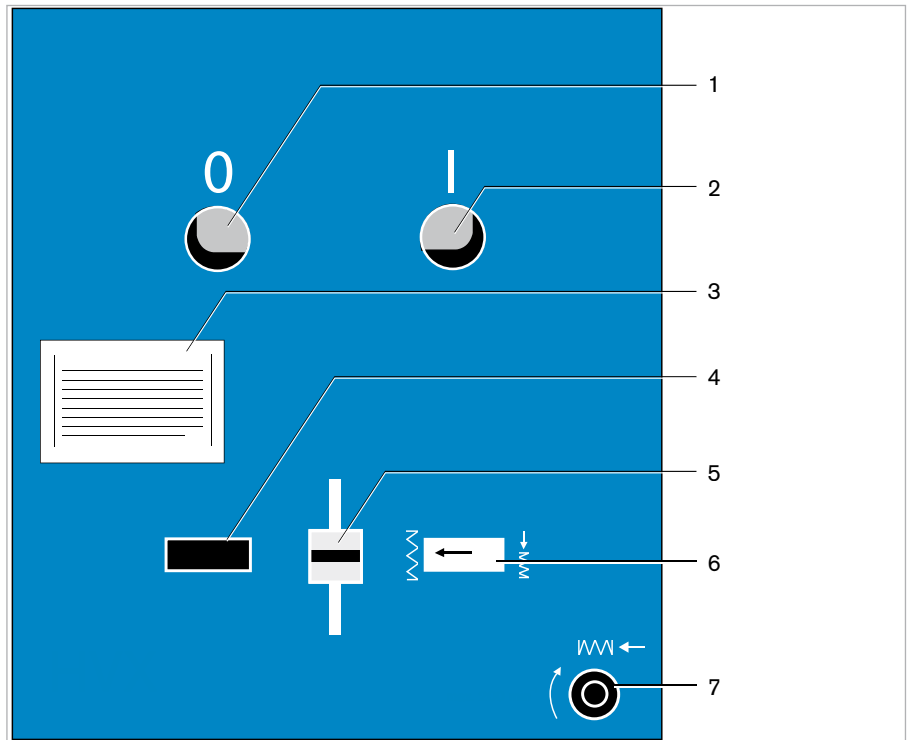

Fig. 37

Operating interface of HVX circuit-breaker with a rated voltage of 12-24 kV

- 1 OFF button (rocker "0")
- 2 ON button (rocker "1")
- 3 Nameplate
- 4 Operation counter
- 5 Position indicator of circuit breaker
- 6 Position indicator of spring mechanism
- 7 Insertion opening for charging the closing spring

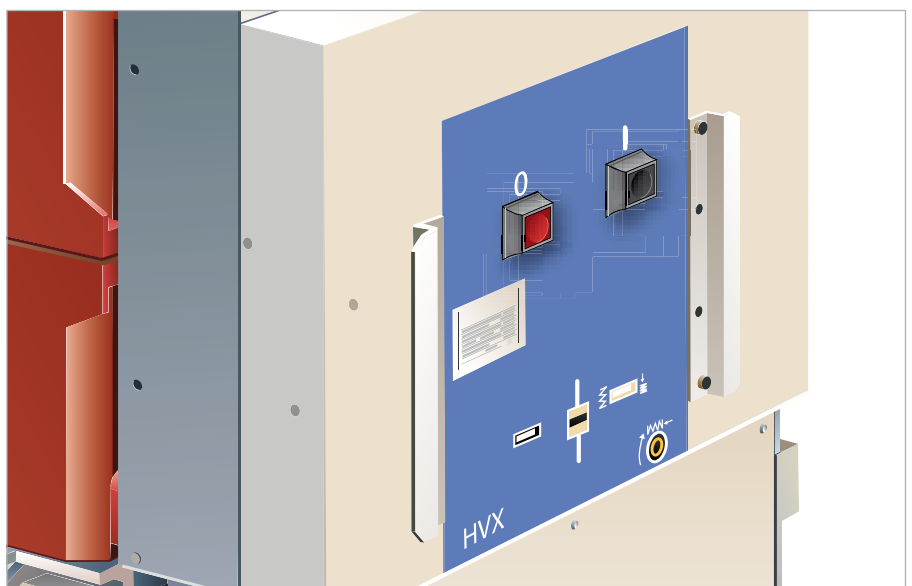

Fig. 38

Operating interface of HVX circuit-breaker (rated voltage 12-24 kV) with push-buttons (optional)

Circuit-breaker HVX-F
 dimensioned for
 $U_r = 36 \text{ kV}$

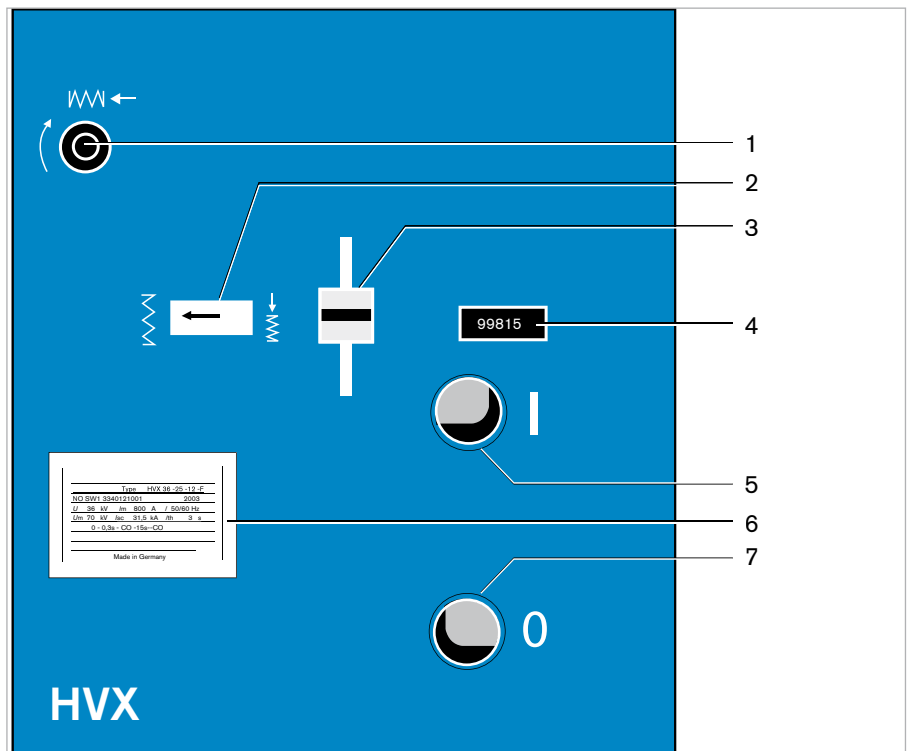

Fig. 39

Operating interface of HVX circuit-breaker (rated voltage 36 kV)

- 1 Insertion opening for charging the closing spring
- 2 Position indicator of spring mechanism
- 3 Position indicator of circuit breaker
- 4 Operation counter
- 5 ON button (rocker "1")
- 6 Nameplate
- 7 OFF button (rocker "0")

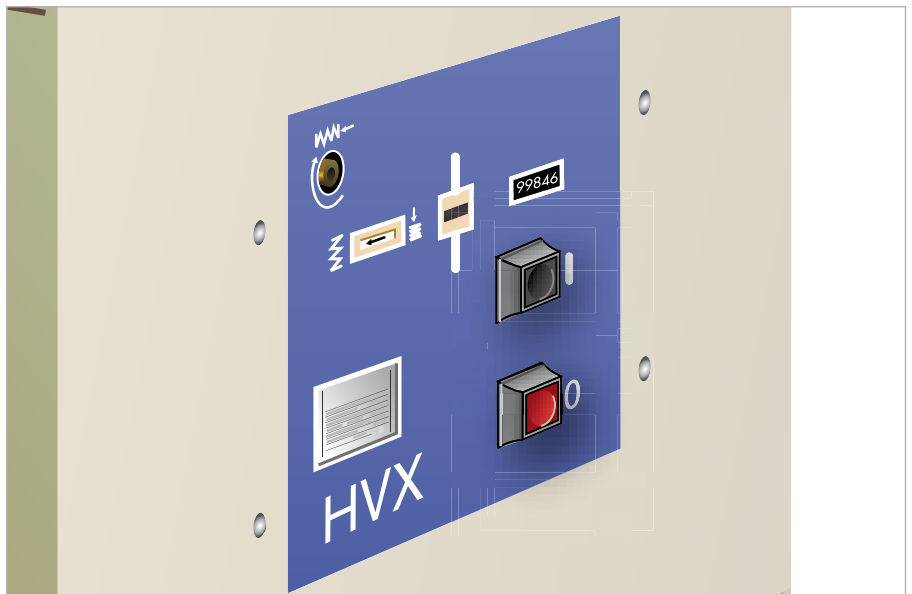

Fig. 40

Operating interface of HVX circuit-breaker (rated voltage 36 kV) with push-buttons (optional)

6.2 Operation accessories



Important:

Only the auxiliary equipment required for operation (depending on the circuit-breaker design) is supplied in the accessories. Only these accessories may be used to operate the circuit-breaker.

Position (Fig. 41)	Designation	Ref. no.
1	Operating rod for ON/OFF actuation	AGS H35 446-01
2	Spring charging crank for energy-storing device	AGS H30 498-01
3	Moving crank handle with integrated slip coupling for disconnecter truck (HVX-E)	AGS H31 601-01 ¹
		AGS H32 532-01 ²
		AGS H31 674-01 ³
4	Moving crank handle for disconnecter truck in PIX High panels	AGS C66 911-01

- 1 Disconnecter truck, manually actuated, shape of insertion opening: hexagonal
- 2 Disconnecter truck, manually actuated, shape of insertion opening: square
- 3 Emergency crank handle for disconnecter truck, motor-actuated

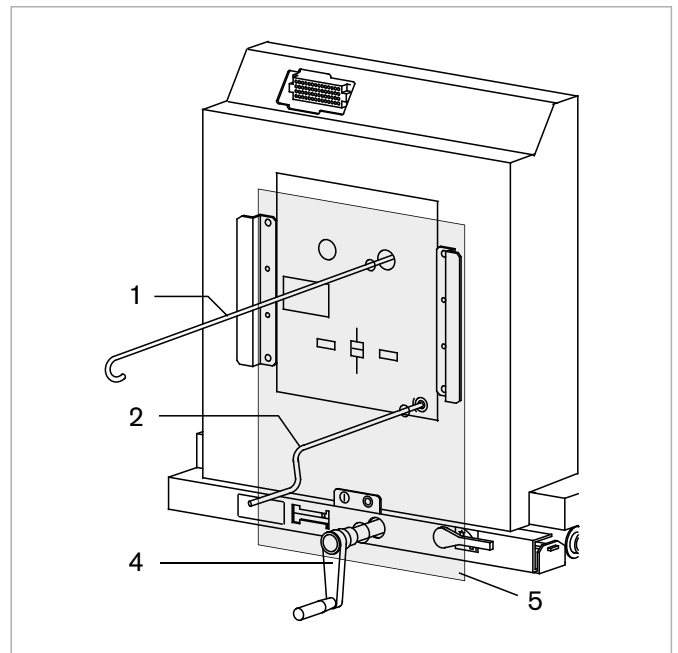
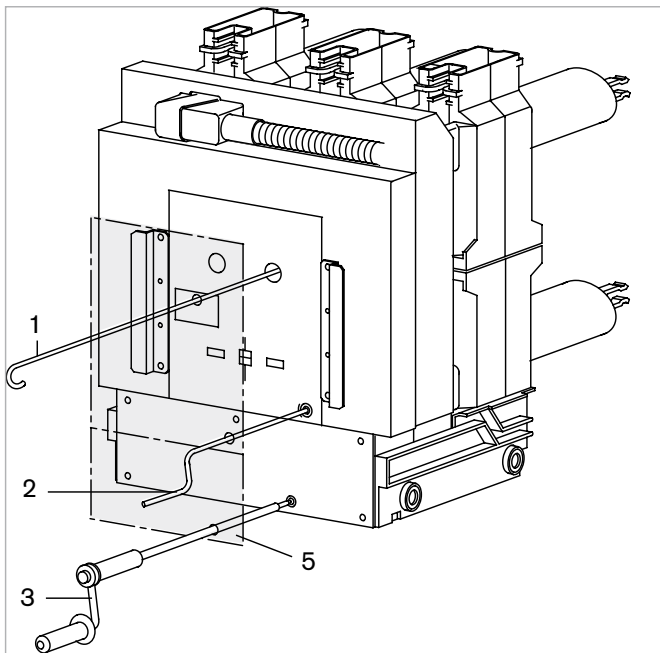

Fig. 41

Accessories for circuit-breaker HVX-F and HVX-E

- 1 Operating rod for ON/OFF actuation
- 2 Spring charging crank for energy-storing device
- 3 Moving crank handle with integrated slip coupling for disconnecter truck (HVX-E)
- 4 Moving crank handle for disconnecter truck in PIX High panels
- 5 Closed door of switchgear panel

6.3 Interlocks



Warning!
Risk of injury. You must be familiar with these interlocks before operating the circuit-breaker.

Electromagnetic interlocks (optional)

The manual operating facilities on the circuit-breaker can be locked optionally by blocking coils. Electromagnetic blocking coils can be used for inter-panel as well as intra-panel interlocks:

- The circuit-breaker's ON and OFF pushbuttons are blocked.
- The insertion opening for the crank to move the circuit-breaker into its disconnected/service position is blocked (only for HVX-E).



Important:

- *In case of failure of the supply voltage, all electrical interlocks are in their "locked" position. Measure: Re-establish power supply.*
- *Please note the purchase contract and the switchgear-specific circuit diagram as regards the design of the interlocking systematics.*

Mechanical interlocks in the HVX-E

The circuit-breaker HVX-E (truck) features mechanical basic interlocks to prevent operating errors:

Interlock	Function of interlock	Method of operation of interlock
Between truck and low-voltage connector	The truck cannot be racked in unless the low-voltage connector is inserted and locked.	The opening for the moving crank handle is locked.
	The low-voltage connector can only be inserted or removed while the truck is in its disconnected position.	The interlock for the low-voltage connector on the drive end has been activated.
Between the truck and the operating state of the circuit-breaker	Circuit-breaker cannot be racked in or out while it is switched on	The opening for the moving crank handle is locked.
	Circuit-breaker cannot be switched on unless <ul style="list-style-type: none"> – it is completely in its disconnected or service position and – the operating crank for the racking-in mechanism has been removed. 	The circuit-breaker cannot be switched ON or OFF.

6.4 Operating specifications

**Warning!**

Risk of injury. Please comply with the safety provisions in Chapter 1 on page 5.

**Warning!**

To rule out risks due to faulty switching operations, the operating sequences described below must be complied with. Each switching operation must be completed.

Check whether the supply voltage is ON.

**Important:**

- When operating the circuit-breaker, observe and comply with the instructions given for the panel used.
- After each switching operation for which you have used a crank or a lever, remove this tool.
- In case supply voltage is not available
 - blocking coils (optional, see Chapter 6.3 on page 34) are in "locked" position;
 - an undervoltage release (optional) has dropped out.
 Measure: Re-establish the supply voltage.
- Comply with the switch-specific mechanical and electromechanical interlocking conditions; see also Chapter 6.3 on page 34.

Specifically for truck actuation**Warning!**



Risk of an arc occurring on switching unless the truck is operated in isolated or deenergized condition. The circuit-breaker must always be switched off previously.

**Important:**

Do not pull the crank out before the truck in question has reached its end position; do not pull it out in an undefined intermediate position.

6.5 Charging the energy storing device

Initial position:

- Circuit-breaker in "OFF" position 
- Energy storing device released 

Manually

1. Insert crank into opening for tensioning the energy storing device (Fig. 42).
2. Turn clockwise, until the charge drive mechanism is uncoupled (sound). The energy storing device indicates the "charged" condition: 
3. Remove crank. The circuit-breaker is ready for closing (Chapter 6.7 on page 37, Table item 2).



Important:

- If the motor drive starts during this process, this does not constitute a risk.
- For manual charging, the speed applied externally must not exceed 200 min⁻¹.

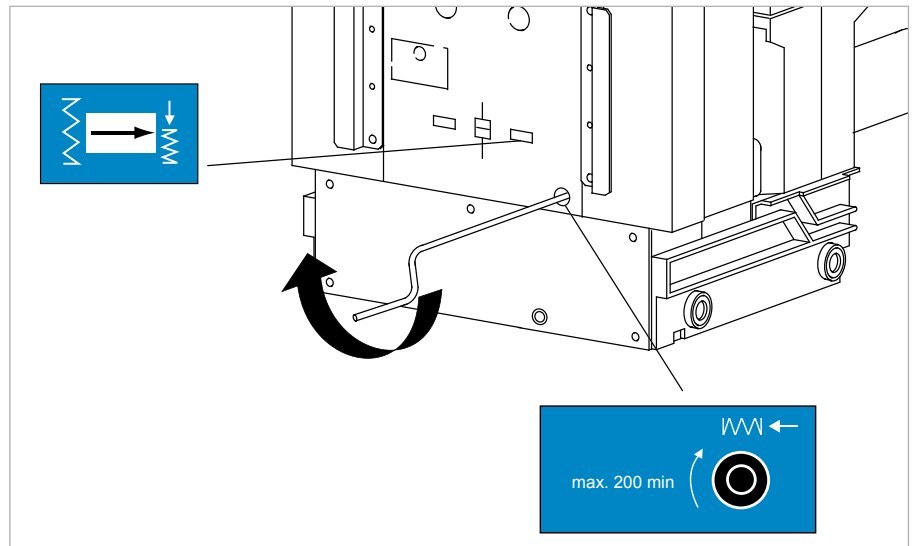

Fig. 42
Charging the energy storing device manually

Via motor-drive

The energy storing device of motorized circuit-breakers is charged automatically as soon as the supply voltage is applied.

6.6 Switching operations

All available versions for switching the circuit-breaker ON and OFF are listed below. Depending on the switch-specific equipment, versions may be shown, but not be available.

Switching ON (Closing)

- Press ON button (I) using the operating rod (Fig. 43, item1) or
- press ON button (I) (Fig. 44, item 3) or
- actuate closing release electrically.

Position indicator indicates the “ON” position (2).

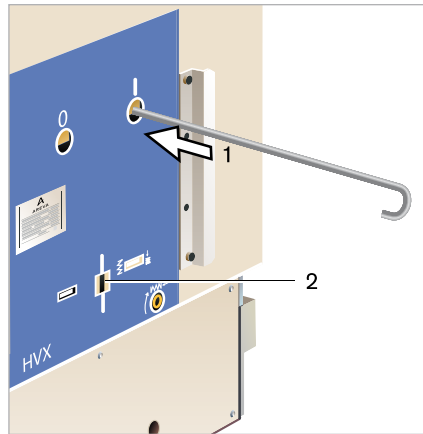

Fig. 43

- 1 Switching ON by means of an operating rod
- 2 Position indicator indicates "ON"

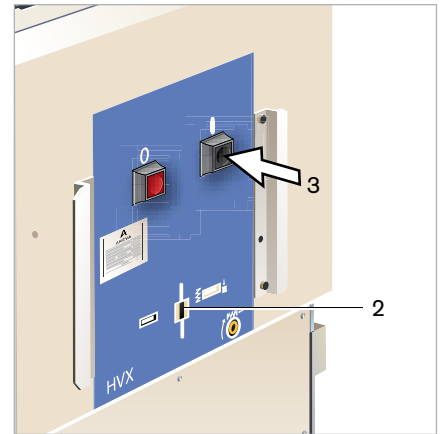

Fig. 44

- 3 Switching ON via pushbutton
- 2 Position indicator indicates "ON"

The energy storing device can be charged again immediately after switching ON (manually or by motor). If voltage is applied to the motor, charging is performed automatically.









The position indicator shows the energy storing device position “charged” (Chaper 6.7, table item 4).

Switching OFF (Opening)

- Press OFF button (O) by means of the operating rod or
- Press OFF button (O) or
- actuate opening release electrically, or
- by undervoltage release or secondary release

The position indicator indicates the switch position OFF (Chapter 6.7, Table item 1 or 2).

6.7 Position indicators on circuit-breaker and possible operating sequences

Item	Position indicator, energy-storing device	Position indicator ON/OFF	Possible operating sequence
1	 released	 OFF	none
2	 charged	 OFF	C-O
3	 released	 ON	O
4	 charged	 ON	O-C-O

C = ON (Close) O = OFF (Open)

6.8 Moving truck into service / disconnected position

Initial situation:

- Circuit-breaker OFF

Racking-in the truck from disconnected into service position

The crank features an integrated slip coupling which prevents damage to the drive mechanism due to an excessive torque. The slip coupling can react if the truck is moved to its final stop in disconnected or service position.

1. Open cover in panel (Fig. 45, item 1) and insert crank (2).
2. Turn crank clockwise (3) until the truck has been racked in. Remove crank.
3. Check position of the truck (Fig. 46) through the inspection port.

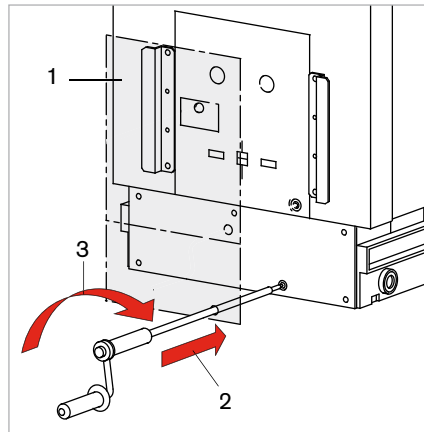

Fig. 45
 1 Open panel cover
 2 Insert crank
 3 Turn crank clockwise

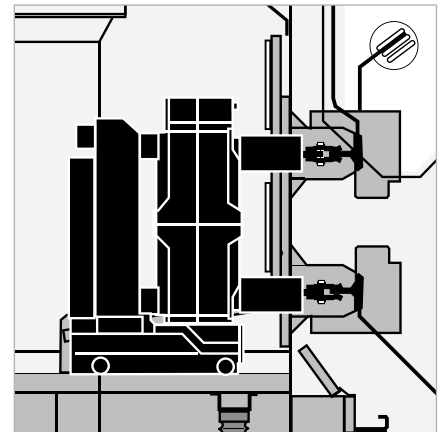

Fig. 46
 Truck in service position

Racking-out the truck from service into disconnected position

1. Open cover in panel (Fig. 47, item 1) and insert crank (2).
2. Turn crank counter-clockwise (3) until the truck has been racked out. Remove crank.
3. Check position of the truck (Fig. 48) through the inspection port.

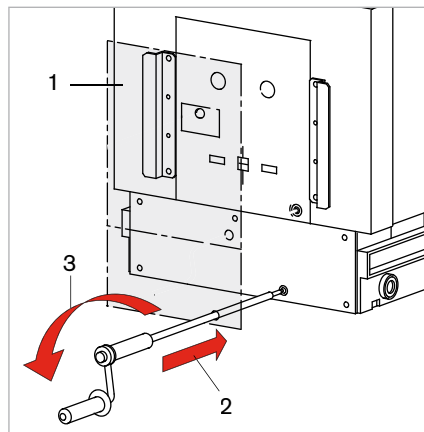

Fig. 47
 1 Open panel cover
 2 Insert crank
 3 Turn crank counter-clockwise

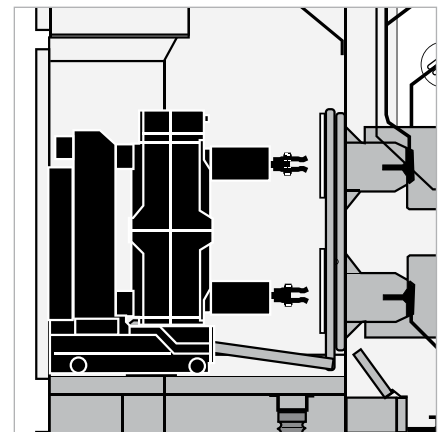

Fig. 48
 Truck in disconnected position

6 Operation

Racking-in the truck for PIX High panels from disconnected into service position

1. Press the interlocking slide (Fig. 49, item 1) to the left and hold it. Insert crank through the opening in the door onto the drive shaft of the truck (2).
2. Turn crank clockwise until the position indicator above the crank indicates "I" (Fig. 49, item 3). Remove crank.
3. Check position of the truck (Fig. 48) through the inspection port.

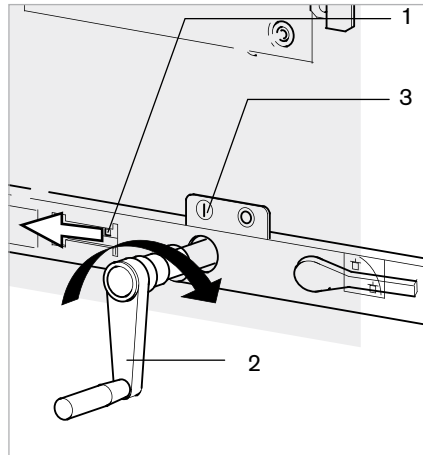

Fig. 49

- 1 Press interlocking slide to the left
- 2 Insert crank and turn it clockwise
- 3 Position indicator "I"

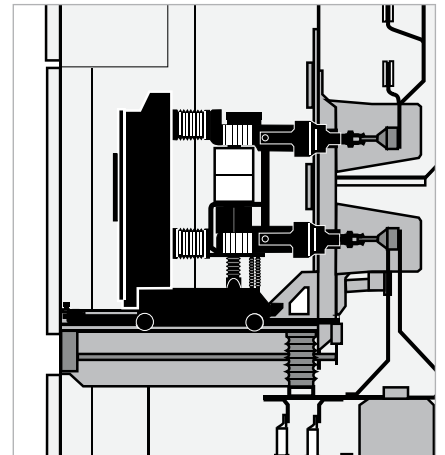

Fig. 50

Truck in service position

Racking-out the truck for PIX High panels from service into disconnected position

1. Press the interlocking slide (Fig. 51, item 1) to the left and hold it. Insert crank through the opening in the door onto the drive shaft of the truck (2).
2. Turn crank counter-clockwise until the position indicator above the crank indicates "O" (Fig. 51, item 3). Remove crank.
3. Check position of the truck (Fig. 52) through the inspection port.

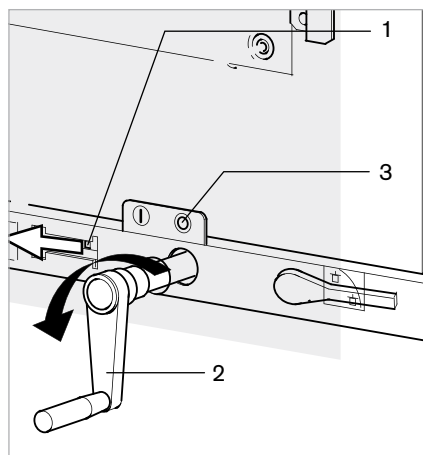

Fig. 51

- 1 Press interlocking slide to the left
- 2 Insert crank and turn it counter-clockwise
- 3 Position indicator: „O“

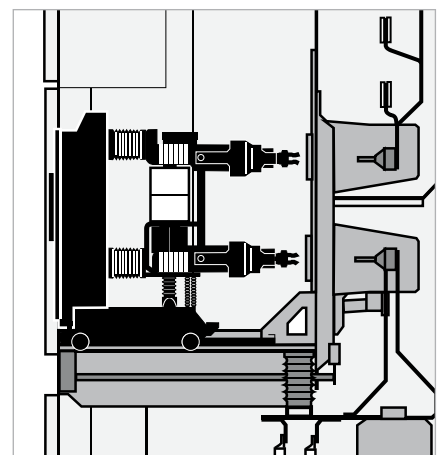

Fig. 52

Truck in disconnected position

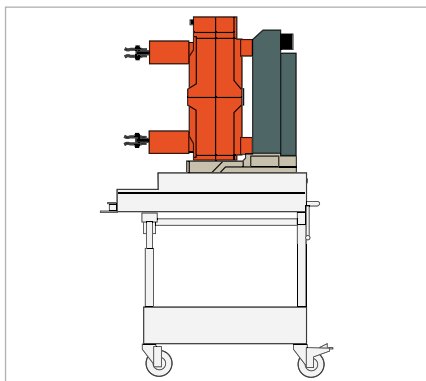

Fig. 53
Transport trolley

7.1 Safety provisions



Warning!
Risk of injury. Please comply with the safety provisions in Chapter 1, page 5.



Warning!
Risk of injury due to mechanically precharged drive components. The circuit-breaker must not be disassembled for maintenance work.

Maintenance and maintenance work may only be performed by specialist electricians who have been certified by the manufacturer for series HVX vacuum circuit-breakers and who are familiar with the appropriate safety provisions.

For inspection and maintenance the circuit breaker HVX-E have to be on the transport trolley (Fig. 53).

7.2 Maintenance and maintenance specifications

Series HVX vacuum circuit-breakers are indoor switching devices designed for normal operating conditions in acc. with IEC 62271-1.

Inspection

It is recommended to check the circuit-breakers visually at regular intervals depending on the strain they are subject to during operation and in accordance with national regulations.



Important:
In case of frequent condensation or air pollution (dust, smoke or corrosive gases), the maintenance intervals must be adapted to the actual conditions.

A visual inspection includes a complete check of the circuit-breaker for contamination, condensation and damage, to be performed by certified staff.

Maintenance

If there are signs of contamination or condensation, the circuit-breakers must be cleaned in an expert manner (see Chapters 7.3 and 7.4 on page 41) and subsequently the drives, interlocks and position indicators checked for proper functioning (see Chapter 6 as of page 31).

Overhauling

If damage is detected, it must be repaired immediately, or components replaced (see Chapter 7.5 and 7.6 on page 41).

In case of ambiguities or irregularities, please contact the manufacturer's Service Center immediately.

Maintenance interval	Maintenance work	Qualification / Work performed by
After 10 000 operating cycles	Revision of circuit-breaker	Manufacturer's Service Center
after 1,000 truck operations	Revision of the truck	
once the max. admissible number of breaking operations for the vacuum chambers has been reached (see Chapter 7.8)	Replacement of vacuum chambers	

7.3 Cleaning insulating components

To ensure the specified insulating level, the insulating components must be clean. On principle, general cleanliness of the circuit-breaker and of its external parts should be ensured.

Slight contamination

Clean using a dry, lint-free cloth. Depending on the degree of soiling, replace cloth as often as necessary.

Severe soiling

Cleaning agent, 1 l can (see Chapter 8.1, page 47) must be used for cleaning. The use of other cleaning agents is not admissible.

- Wear protective gloves
- Use cleaning agent according to manufacturer's instructions.
- Soak the cloth thoroughly and wipe the insulating components. Keep duration of exposure as short as possible.
- Expose the cleaned surface to the air for at least two hours.

When cleaning, make sure that the lubrication in the drive mechanisms is not removed. If the drives are no longer sufficiently lubricated, replace the grease (see Chapter 7.7 on page 42).

7.4 Avoiding condensation

To ensure the specified insulating level, the circuit-breaker – especially its insulating components – must not be exposed to condensation.

1. If condensation is detected, clean the circuit-breaker (see Chapter 8.3 on page 48).
2. Check heating system or install a heating. It must provide a sufficient heating performance to prevent condensation on the circuit-breaker.
3. Condensation can also be prevented by ensuring suitable ventilation and heating of the station or by using de-humidification devices.

7.5 Corrosion protection

Drive mechanisms and covers have a long-term protection against corrosion. Any damage to the paint, scratches and other damage must be repaired immediately to avoid corrosion. Contact the manufacturer's Service Center.

7.6 Replacement of components

Drive or live high-voltage components may be replaced as required.

The following data on the nameplate are relevant for replacement of components or in case of any queries (see also Chapter 2.6, page 11):

- Type designation
- Serial number
- Year of construction

If you have any queries regarding replacement of components, please contact the manufacturer's Service Center.

7.7 Lubrication instructions

**Important:**

- The bearings and joints must not be washed out by the cleaning agent.
- The following elements must not be lubricated:
 - Motor
 - Ball bearings
 - Auxiliary releases
 - Micro switches
 - Blocking coils
 - Auxiliary switches
- Only approved lubricants may be used (see Chapter 8.1, page 47).

Truck mechanism

- Spindle of truck mechanism (Fig. 54, item 1). The spindle is accessible from below
- Geared wheels of truck mechanism (only in case of motor-drive) (Fig. 54, item 2). The geared wheels are accessible once the lower front cover has been removed.

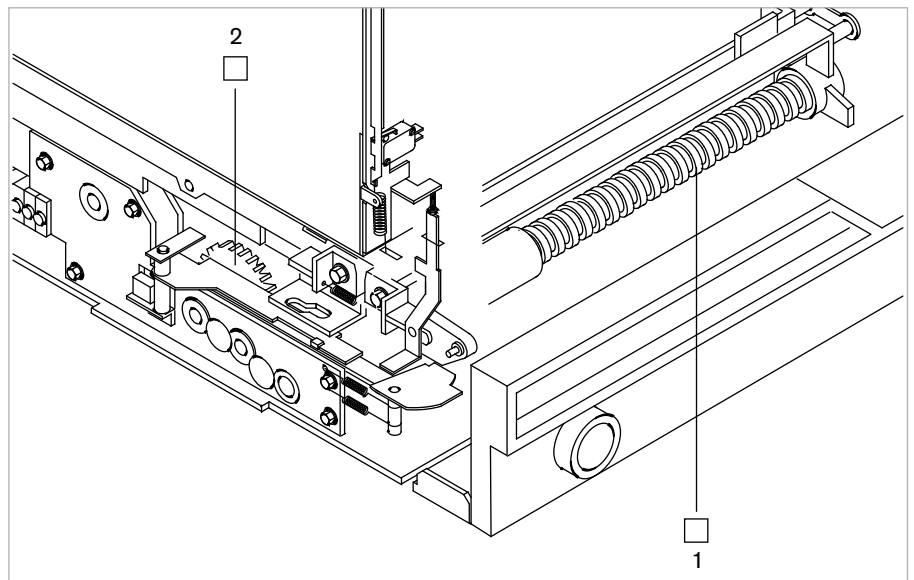

Fig. 54
Points of lubrication of the racking-in mechanism

- High-pressure grease
- 1 Spindle
- 2 Geared wheels

Truck mechanism in the HVX-E for PIX High panels

To have access to the points of lubrication, make sure that the disconnecting truck is in service position.

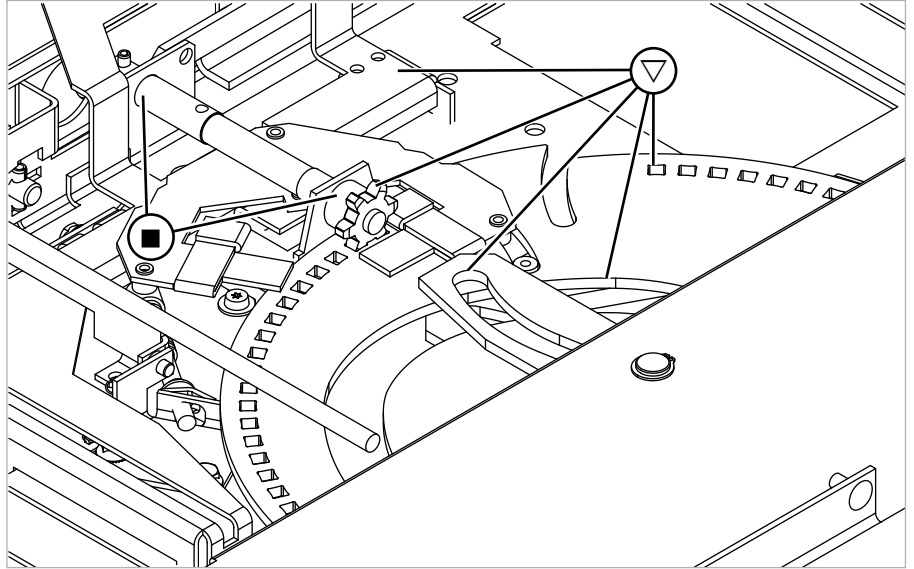

Fig. 55
Points of lubrication of the racking-in mechanism of HVX circuit-breakers in PIX High panels

▽ synthetic lubricant ■ Liquid lubricant FL

Lubricant	Points of lubrication	Lubrication procedure
Synthetic lubricant	All accessible friction and sliding points in the disconnecter truck	Clean lubricating points using a lint-free cloth or a soft paint-brush, if necessary using cleaning agent (use sparingly, just moisten points of lubrication). Apply a thin coat of lubricant (using e.g. a paintbrush).
Liquid lubricant FL	Bearing, joints and guide mechanisms in the disconnecter truck	Pour drops of liquid lubricant (oil can, drip feed lubricator) into the bearing gap. Liquid lubricant gets between the bearing surfaces due to the capillary effect. In case of inaccessible lubrication points, use an extension tube or spray.

Moving contacts

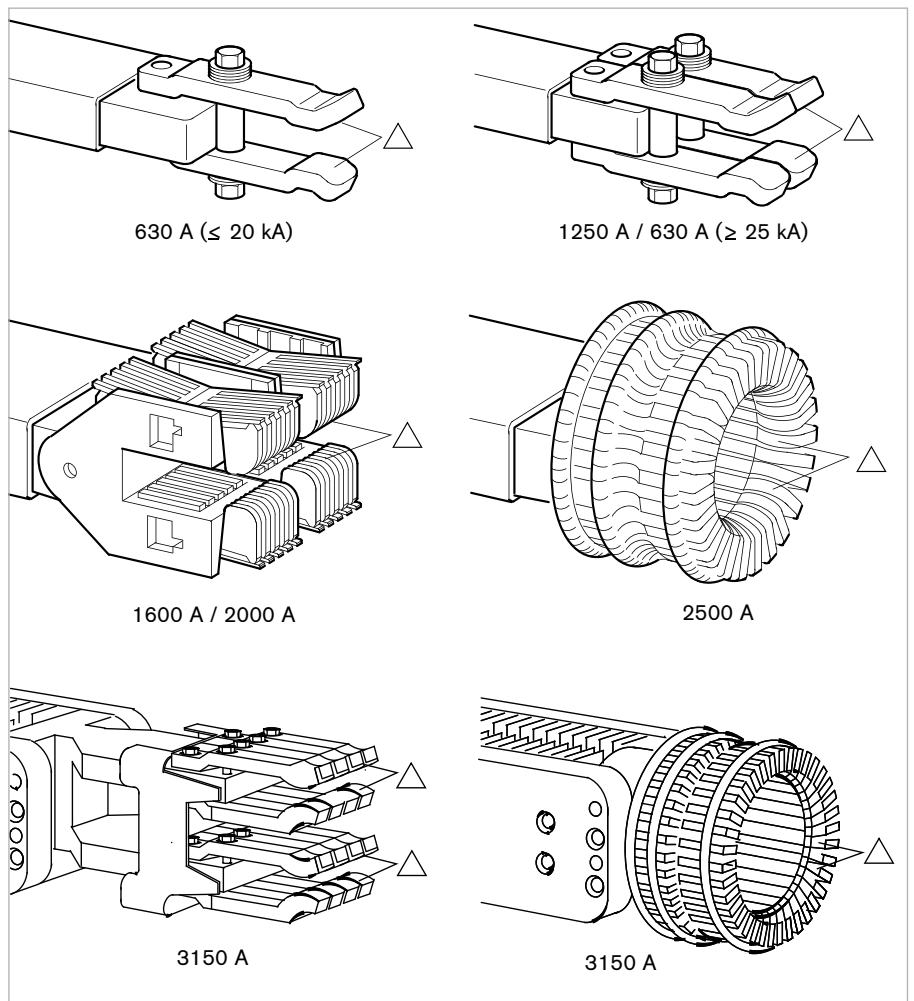

Fig. 56
 Greasing the moving contacts
 △ Contact grease (Kontasynth)

Circuit-breaker

Remove operating Interface:

Tools: TORX screwdriver, size T25 / slotted screwdriver

Remove the five M5 screws on the front and remove the operating panel.

Lubricant	Symbol	Points of lubrication	Lubrication procedure
Silicone grease	●	Drive mechanism: lever on plastic housing of spring charging mechanism	Clean lubricating points using a lint-free cloth or a soft paint-brush, if necessary using cleaning agent (use sparingly, just moisten points of lubrication). Apply a thin coat of lubricant (using e.g. a paintbrush).
Cryogenic grease	○	Drive mechanism: roller levers	
High-pressure grease	□	Drive mechanism: cam discs, cog-wheels, semi-shafts and all other friction points	
Contact grease (Kontasynt)	△	Racking-in contacts, earth bar	

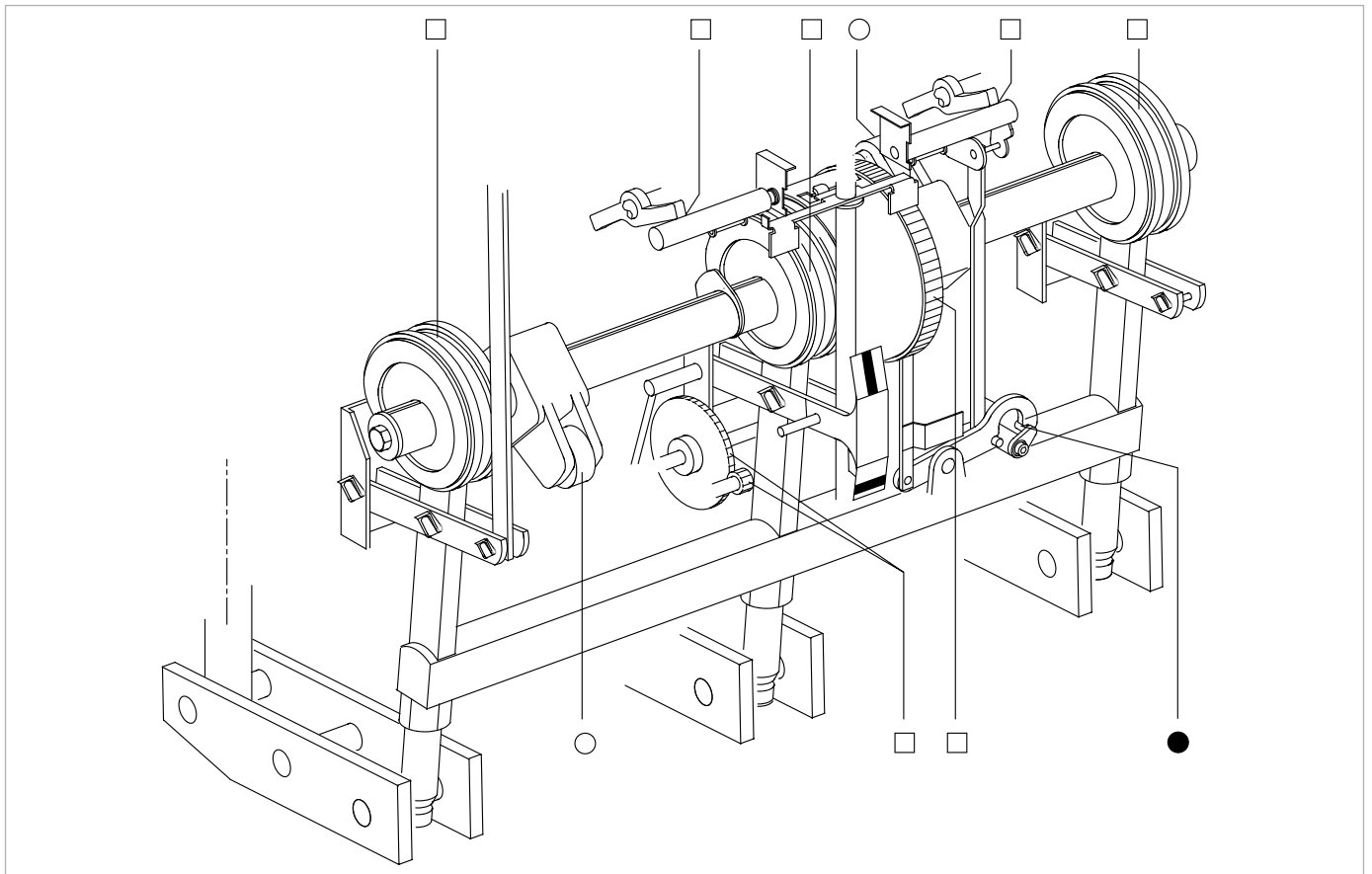

Fig. 57

Points of lubrication on the circuit-breaker drive mechanism

□ High-pressure grease ○ Low-temperature grease ● Silicone grease

Final steps

Mount operating interface and insert circuit-breaker in panel (see Chapter 4 “Assembly” as of page 17). Check circuit-breaker in acc. with Chapter 5 “Commissioning” as of page 29.

7.8 Maximum admissible numbers of breaking operations of vacuum chamber

The diagram (Fig. 59) defines exclusively the max. admissible numbers of breaking operations of the circuit-breaker depending on the rated normal current I_r and of the short-circuit breaking current I_{sc} . It indicates when the vacuum interrupter chambers need to be replaced.

The diagram shows examples of values for the rated normal current I_r and the short-circuit breaking current I_{sc} .

The data for the rated normal current I_r and the short-circuit breaking current I_{sc} are indicated on the nameplate (Fig. 58).

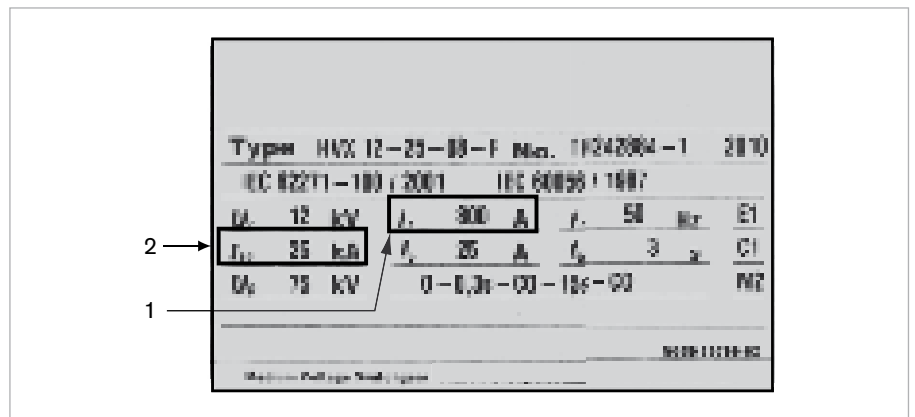

Fig. 58 Data for rated normal current I_r (1) and short-circuit breaking current I_{sc} (2) on the nameplate

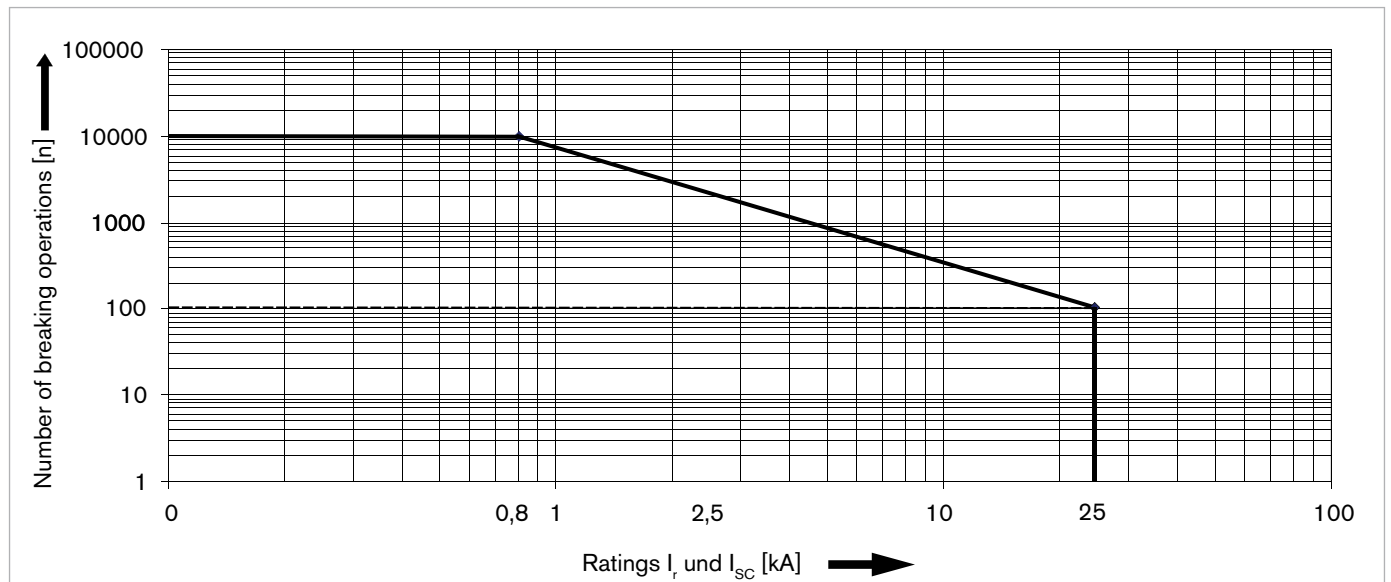

Fig. 59 Admissible breaking numbers for the vacuum chamber with values (example)
 I_r = rated normal current = 0.8 kA
 I_{sc} = short-circuit breaking current = 25 kA

8.1 Auxiliary products

The auxiliary products are available from the manufacturer. The use of alternative auxiliary products is not permissible.



Warning!
Risk of injury if these products are handled improperly.
Observe the safety data sheets of the manufacturers of the auxiliary products.

Designation	Symbol	Ref. no.
Cleaning agent, 1-l can		S 008152
Contact grease ¹	△	ST 312-340-001
High-pressure grease ¹	□	ST 312-101-001
Low-temperature grease ¹	○	ST 312-105-001
Silicone grease ¹	●	ST 312-504-001
Synthetic lubricant	▽	ST 312-111-001
Liquid lubricant FL	■	S 008153
Touch-up pen RAL 7044, silk-grey, 50 ml		S 009 561
Touch-up pen, special paint (specify colour shade)		S 009 562

¹ The size of the packing unit is not defined. It will be defined upon consultation with the manufacturer.

8.2 Treatment of firmly screw-connected contact surfaces



Important:

- Caution when handling bars insulated by heat-shrinkable sleeves: The heat-shrinkable sleeve must not get into contact with contact grease (swelling).
- Contact areas coated with contact grease should not be touched, if possible.

1. Contact areas must be subjected to preliminary treatment before screw-fastening (see Table below)
2. Immediately after the pre-treatment, coat the contact surfaces with contact grease, so that the space between the contact surfaces is completely filled once the screws have been connected.

Material of contact surfaces	Pre-treatment
Silver-plated	Cleaning ¹
Copper or copper alloy	Clean ¹ , expose metallic surface ²
Steel	Clean ¹ , expose metallic surface ²
Zinc-plated steel	Remove passivation, not, however, the zinc layer ³
Hot-galvanized sheet-metal	Clean ¹ , passivation need not be removed

- ¹ by means of lint-free cloth; use cleaning agent in case of serious contamination
- ² – by treating the entire surface with emery cloth or a rotating grinding tool (grain size 100 or 80) or
 – using a wire brush which is clearly marked for use exclusively for aluminium or exclusively for copper
- ³ with brass or steel brush

8.3 Specifications for screw connections



Important:

The threads of screws and bolts must generally not be pre-treated.

- Max. tolerance for the effective tightening torques: $\pm 15\%$
- The nut must correspond in strength to the grade of the screw/bolt used or be of better quality.

General screw connections

	Grade or material		
Screw/bolt	Plastics	$\geq 8.8 \leq 10.9$	Self-locking screw ≥ 8.8
Thread \varnothing	Tightening torques [Nm]		
M 4	0.25	2.6	
M 5	0.5	5.0	7.0
M 6	0.8	8.8	12.3
M 8	1.8	21.0	30.0
M 10	3.5	42.0	59.0
M 12	6.0	70.0	97
M 16	12	170	
M 20		330	

Screw fastening for power transmission

Screw connection for terminal strips

Screws and bolts: Grade ≥ 8.8

Conductor material: copper	
Thread \varnothing	Tightening torques [Nm]
M 6	6.5
M 8	17
M 10	35
M 12	68
M 16	135

Thread \varnothing	Tightening torques [Nm]
M 2.5 (M 2.6)	0.5
M 3	0.7
M 3.5	1.0
M 4	1.5
M 5	2.5

Schneider Electric
35, rue Joseph Monier
CS 30323
92506 Rueil-Malmaison Cedex, France

RCS Nanterre 954 503 439
Capital social 896 313 776 €
www.schneider-electric.com

AGS 531 301-01

As standards, specifications and designs change from time to time, please ask for confirmation of the information given in this publication.



*This document has been printed
on ecological paper*

Publishing: Schneider Electric
Design: Schneider Electric
Printing: