

# Vigirex

Residual-current protection relays





Machines

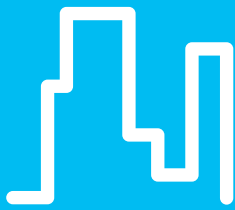

Buildings



Retail



Hospitals



Airports



Electrical  
energy

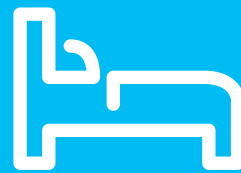

Hotels



Industry

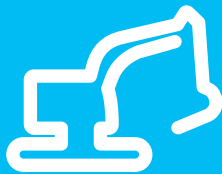

Mining

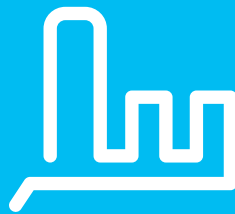

Refineries

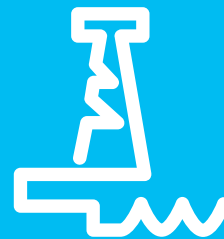

Off-shore

- > Designed for all types of distribution systems and all voltages
- > Wide range of auxiliary supply voltages
- > Wide setting and operating possibilities
- > Wide range of compatible sensors up to 3200 A
- > Compatible with all electrical switchgear devices on the market

# Vigirex

All Schneider Electric's expertise in earth leakage protection.

- > A very wide range of applications.
- > Guaranteed efficiency of all protection chain components for complete safety.
- > Optimised continuity of supply and protection of people and equipment, unmatched on the market.
- > Compliance with all international standards.





Designed for all types of distribution systems and all voltages.

Wide range of auxiliary supply voltages.

Wide setting and operating possibilities.

Wide range of compatible sensors up to 3200 A:

- > A-type closed toroids: TA30, PA50, IA80, MA120, SA200 and GA300
- > TOA-type split toroids: TOA80 and TOA120
- > rectangular sensors L1, L2.

For all types of installations

Vigirex relays are designed to operate with all electrical switchgear devices on the market.

## Protection



## Circuit monitoring



## Installation monitoring



# Complete range of devices for protection and monitoring

## Compliance with international standards

The residual-current relays comply with all the major standards worldwide, in particular those dealing with:

- > residual-current protection: IEC 60755 and IEC 60947-2 annex M for the protection of life and property. The Vigirex range is also certified by the independent KEMA laboratories. It has successfully passed test sequences MI/MII/MIII/MIV of standard IEC 60947-2 (annex M).
- > installation: IEC 60364
- > electromagnetic compatibility (EMC): IEC 61000
- > coordination of insulation: IEC 60664.

and North-American standards dealing with  :

- > ground fault protection: UL 1053 and CSA C22.2 N° 144 (protection of equipment and property) (RH10, RH21 and RH99 up to 240 V).



RH197M



RH10/RH21



RH10/RH21



RH10/RH21



RH10/RH21



RH10/RH21

**Vigirex residual-current relays, with associated toroids,** measure the earth-leakage current in the electrical installation.

They provide:

- > residual-current protection: RH10, RH21 and RH99
- > earth-leakage monitoring: RH99 and RMH
- > residual-current protection and earth-leakage monitoring: RH197, RHUs and RHU.

### The protection relays

interrupt the supply of power to the monitored system in the event of a fault.

They protect:

- > people against direct and indirect contact
  - > equipment and property against fire.
- They store the residual-current fault in memory and order opening of the associated circuit breaker when the set residual operating current  $I_{\Delta n}$  is overrun.

Depending on the relay, the threshold  $I_{\Delta n}$  is fixed, user-selectable or adjustable.

### The monitoring relays

indicate overruns of leakage current thresholds.

They reset automatically when the fault is no longer present.

When used in conjunction with an auto-reclosing controller, they protect against earth faults caused by insulation failures on:

- > telephone relays
- > radio repeaters
- > special applications.

Vigirex relays can be used at all levels of an installation: LV incomers, power distribution, industrial control and final distribution.

They are designed for AC installations implementing IT, TT and TN-S earthing arrangements and are suitable for voltages up to 1000 V and frequencies from 50/60 Hz up to 400 Hz.

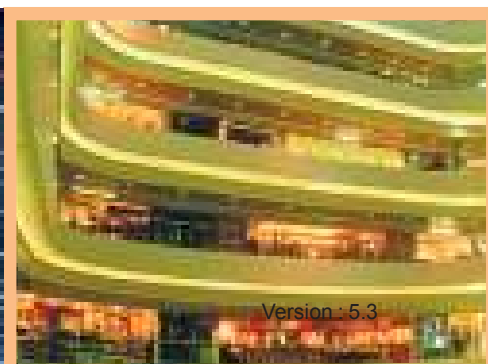

# Absolute protection of life and property



The overrun of leakage current thresholds may represent a threat to life and property if it is not immediately located. Through permanent monitoring of this overrun, the Vigirex range makes the protection efficient.

## Class

# 2

### front panel insulation

Class II insulated front panel certification for the entire range as per standards IEC/EN 60664-1 and NFC 15-100.

## Maximum safety

Vigirex residual current devices (RCDs) with appropriate settings provide effective protection of life and property. The characteristics of the relay/toroid combination ensure reliable measurements.

## Operation guaranteed in less than 40 ms

Schneider Electric guarantees the safe clearing of faults by Vigirex relays set to 30 mA and combined with any of its circuit breakers rated up to 630 A.

## Overvoltage category IV

The reinforced insulation of Vigirex relays (overvoltage category IV, i.e. the most severe category) makes direct connection possible at the head of the installation or on the upstream busbars without any additional galvanic isolation.

## Continuous self-monitoring

Vigirex relays continuously monitor the power supply, relay/toroid link and internal electronics. Failure of the detection circuit is signalled and may be used to trip the circuit breaker. The LEDs on the front panel can also be used to check operation at any time.

## Settings protected by a lead-sealable cover

Access to settings can be protected by a cover with a lead seal. The test and reset buttons remain accessible on the front panel of the relay.

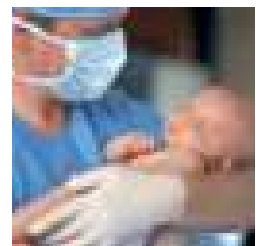

## Detection

with associated toroid

## Alarm

with the Vigirex relay

A  
**three-step**  
process

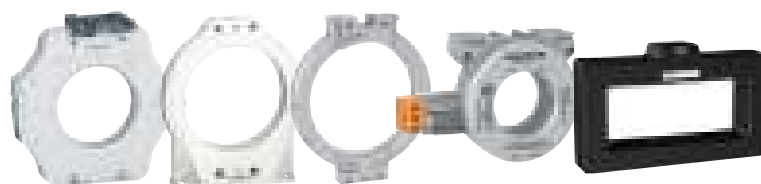

1

# Optimum continuity of service



The entire range offers numerous settings possibilities that may be used to create many discrimination levels, from the incomer to the final output circuits. With Vigirex, unnecessary downtime is eliminated.

## Diagnosis of installation faults

The indication relays are used to:

- > monitor electrical insulation faults,
- > prevent outages,
- > initiate preventive maintenance.

## Minimise outages

Correct setting of the residual current devices (RCDs) ensures total discrimination for insulation faults in the installation, i.e. only the faulty section is shut down. Elimination of most cases of RCD nuisance tripping ensures both safety and continuity of service, two indispensable features for users.

## Reduced tripping tolerance

Vigirex relays trip between 0.8 et  $1 \times I_{\Delta n}$ , thus increasing immunity to nuisance tripping by 60% compared to the earth leakage protection requirements of standard IEC 60947-2.

During circuit energisation, the inverse-time tripping curve makes it possible to avoid nuisance tripping of the earth leakage protection system by false zero phase sequence currents caused by:

- > high transient currents of certain loads (e.g. motors, LV / LV transformers),
- > the charging of capacitances between active conductors and earth.

## Frequency filtering and true RMS measurement

Frequency filtering by Vigirex residual current relays ensures maximum protection against insulation faults and a particularly high level of continuity of service.

Frequency converters such as variable speed drives generate high levels of high-frequency leakage currents. During normal operation, these leakage currents are not a danger to users. The residual current relay measures all types of signals and calculates the true RMS value weighted to allow for frequency filtering.

## Test and reset

To monitor the protection or indication system, the relay includes a complete test function with or without tripping of the protection device.

Moreover, the purpose of the test is to check:

- > the output contacts,
- > the display (RHU/RHUs and RMH),
- > the LEDs,
- > the internal electronics.

## Centralised test

One or more relays can be tested remotely, with or without tripping the associated breaking device.



## Protection

with the circuit breaker



2

3



## Formats for all installation systems

Schneider Electric Moulded Circuit Breaker format devices in the Vigirex range can be mounted on a DIN rail (RH10, RH21, RH68, RH86, RH99 and RH197) or on a universal mounting plate using mounting lugs (RH10, RH21, RH68, RH86 and RH99). The 72 x 72 mm front-panel mount devices (RH10, RH21, RH68, RH86, RH99, RH197, RMH, RHUs and RHU) are mounted on panels, doors or front plates using clips.

Installation system	Suitable format	
	Front-panel mount	DIN rail
Main LV switchboard	●	
Power distribution switchboard	instrument zone	
	modular-device zone	●
Motor Control Centre (MCC)		● with clip-in toroid
Automatic control panel or machine panel		● with mounting lugs
Final distribution enclosures		●



### RHU

- > Panel device.
- > Adjustable tripping threshold from 30 mA to 30 A.
- > Adjustable pre-alarm of the tripping threshold value.
- > New HMI with keyboard unit display by LED.
- > Modbus communication SL RS485.



### Clip-in toroid and plug-in connectors

Plug-in connectors allow easy and secure disconnection for switchboard acceptance dielectric tests. DIN-format Vigirex relays can be equipped with a toroid of 30 to 50 mm in diameter.



DIN device with mounting lugs secured to a mounting plate





## Certified quality: ISO 9001: 2000

Our efforts are based on a Quality Management System to enhance the effectiveness of our processes, the goal being to ensure continuous improvement in compliance with standard ISO 9001: 2000.

Our quality objectives are built into our products right from the design phase.

We are committed to implementing the five key points of our quality policy:

- > measurement of customer satisfaction
- > solidly built products
- > control of the manufacturing process
- > management of development projects
- > commitment of all those involved.

## CE marking

The CE marking, created by European legislation, is designed to provide assurance that the product is not dangerous, non-polluting and immune to electromagnetic disturbances (EMC directive).

## A never-ending commitment

Environmental protection, a reduction in raw materials consumed, controlled energy consumption and product recycling are taken into account right from the beginning of the design phase and on all the Group's production sites.

During design, Schneider Electric uses high-performance tools to assess and reduce the impact of its products on the environment throughout their life cycles.

EIME (Environmental Information and Management Explorer) CAD software assists designers in selecting materials and designing products.

## Production units certified ISO 14001







The production unit benefits from the environmental-management system set up on each ISO 14001 certified site to guarantee continuous progress.

## Easy sorting and recycling

The plastics used are marked to ensure easy identification for sorting and recycling.



If burned, no polluting substances are released.



	Functions and characteristics	A-1
	Installation recommendations	B-1
	Dimensions and connections	C-1
	Wiring diagrams	D-1
	Additional characteristics	E-1
	Catalogue numbers	F-1



<b>Selection guide</b>	<b>A-2</b>
<b>Operation and use</b>	<b>A-6</b>
<b>General characteristics</b>	<b>A-7</b>
<b>Discrimination between residual-current devices</b>	<b>A-14</b>
<b>Electromagnetic compatibility</b>	<b>A-15</b>
<b>Description</b>	
RH10M, RH21M, RH68M, RH86M and RH99M relays	A-16
RH197M relays	A-17
RH10P, RH21P, RH86P and RH99P relays	A-18
RH197P relays	A-19
RHUs and RHU relays	A-20
RMH relay and RM12T multiplexer	A-21
RHU and RMH communication	A-23
Sensors	A-25
<b>Characteristics</b>	
Protection relays with output contact requiring local manual reset after a fault	A-26
Monitoring relays with output contact that automatically resets after fault clearance	A-32
Sensors	A-36
<i>Installation recommendations</i>	<i>B-1</i>
<i>Dimensions and connection</i>	<i>C-1</i>
<i>Wiring diagrams</i>	<i>D-1</i>
<i>Additional characteristics</i>	<i>E-1</i>
<i>Catalogue numbers</i>	<i>F-1</i>



		Protection relays <sup>(2)</sup>			
		RH10	RH21	RH68	
<p>All Vigirex products are type A <sup>(1)</sup> devices, also covering the requirements of type AC devices.</p>					
<b>Functions</b>					
Protection		■	■	■	
Local indications		■	■	■	
Remote indications (hard-wired)		-	-	-	
Remote indications (via communication)		-	-	-	
Display of measurements		-	-	-	
<b>Wiring</b>					
Optimum continuity of service		■	■	■	
Optimum safety (failsafe)		■	■	■	
<b>Mounting</b>					
DIN rail		■	■	■	
Front-panel mount		■	■	-	
<b>Rated operational voltage</b>					
1 DC voltage range from 12 to 48 V		■	■	-	
1 DC voltage range from 24 to 130 V		-	-	-	
5 AC voltage ranges from 12 to 525 V		■	■	-	
4 AC voltage ranges from 48 to 415 V		-	-	-	
1 AC voltage range from 220 to 240 V		-	-	■	
2 AC voltage ranges from 110 to 240 V		-	-	-	
<b>Thresholds</b>					
Fault (I $\Delta$ n)		<b>1 fixed instantaneous threshold</b> choose from 0.03 A to 1 A	<b>2 user-selectable thresholds</b> 0.03 A or 0.3 A	<b>6 user-selectable thresholds</b> from 0.03 A to 3 A	
Alarm		-	-	-	
Pre-alarm		-	-	-	
<b>Time delay</b>					
Fault		<b>Instantaneous</b>	<b>1 user-selectable time delay</b> instantaneous or 0.06 s for I $\Delta$ n = 0.3 A	<b>Instantaneous</b> for I $\Delta$ n = 0.03 A <b>8 user-selectable time delay</b> instantaneous to 1 s	
Alarm		-	-	-	
Pre-alarm		-	-	-	
<b>Display and indications</b>					
Voltage presence (LED and/or relay) <sup>(3)</sup>		■	■	■	
Threshold overrun	fault (LED)	■	■	■	
	alarm (LED and relay)	-	-	-	
	pre-alarm (LED and relay)	-	-	-	
Leakage current (digital)		-	-	-	
Settings (digital)		-	-	-	
<b>Test with or without actuation of output contacts</b>					
Local		■	■	■	
Remote (hard-wired)		■	■	■	
Remote (hard-wired for several relays)		■	■	-	
Remote (via communication)		-	-	-	
<b>Communication</b>					
Suitable for supervision		-	-	-	
<b>Characteristics</b>		<a href="#">page A-26</a>	<a href="#">page A-26</a>	<a href="#">page A-27</a>	
<b>Sensors</b>					
Schneider Electric A and TOA toroids <sup>(4)</sup>	up to 630 A	■	■	■	
Schneider Electric rectangular sensors	up to 3200 A	■	■	■	

(1) Type A relay up to I $\Delta$ n = 5 A.



(2) Relay with output contact requiring local, manual reset after fault clearance.

(3) Depending on the type of wiring (optimum continuity of service or optimum safety).

(4) See characteristics [page A-36](#).

RH86	RH99	RH197M	RH197P	RHUs or RHU
 <small>PB108176-22.eps</small>  <small>PB108175-22.eps</small>	 <small>PB100434-19_SE.eps</small>  <small>PB100432-19_SE.eps</small>	 <small>PB104914-Reps</small>	 <small>PB100715-19_SE.eps</small>	 <small>PB114686-R2.eps</small>
■	■	■	■	■
■	■	■	■	■
-	-	■	■	■
-	-	-	-	■ except RHUs
-	-	■ (5)	■ (5)	■
■	■	■	■	■
■	■	■	■	■
■	■	■	-	-
■	■	-	■	■
-	■	-	-	-
-	-	■	■	-
-	■	-	-	-
-	-	■	■	-
■	-	-	-	-
-	-	-	-	■
<b>6 user-selectable thresholds</b> from 0.03 A to 10 A	<b>9 user-selectable thresholds</b> from 0.03 A to 30 A	<b>19 user-selectable thresholds</b> from 0.03 A to 30 A	<b>19 user-selectable thresholds</b> from 0.03 A to 30 A	-
-	-	Fixed: 50 % I <sub>Δn</sub> or 100 % I <sub>Δn</sub>	Fixed: 50 % I <sub>Δn</sub> or 100 % I <sub>Δn</sub>	<b>1 adjustable threshold</b> from 0.03 A to 30 A
-	-	-	-	<b>1 adjustable threshold</b> from 0.015 A to 30 A
<b>Instantaneous</b> for I <sub>Δn</sub> = 0.03 A <b>6 user-selectable time delay</b> instantaneous to 0.5 s	<b>Instantaneous</b> for I <sub>Δn</sub> = 0.03 A <b>9 user-selectable time delay</b> instantaneous to 4.5 s	<b>7 user-selectable time delay</b> instantaneous to 4.5 s	<b>7 user-selectable time delay</b> instantaneous to 4.5 s	-
-	-	instantaneous	instantaneous	<b>1 adjustable threshold</b> instantaneous to 4.5 s
-	-	-	-	<b>1 adjustable threshold</b> instantaneous to 4.5 s
■	■	■ (6)	■ (6)	■
■	■	■	■	-
-	-	■	■	■
-	-	-	-	■
-	-	by bargraph	by bargraph	■
-	-	-	-	■
■	■	(7)	■	■
■	■	■	■	■
-	■	-	-	-
-	-	-	-	■ except RHUs
-	-	-	-	■ except RHUs
page A-27	page A-26	page A-27	page A-27	page A-27
■	■	■	■	■
■	■	■	■	■

(5) On a bargraph.  
(6) No voltage presence relay.  
(7) With actuation of contacts only.

		Monitoring relays <sup>(2)</sup>	
		RH99	RHUs or RHU
<p>All Vigirex products are type A<sup>(1)</sup> devices, also covering the requirements of type AC devices.</p>		 PB10423-10_SE.eps	 PB10432-19_SE.eps
<b>Functions</b>			
Protection		-	-
Local indications		■	■
Remote indications (hard-wired)		■	■
Remote indications (via communication)		-	■ except RHUs
Display of measurements		-	-
<b>Wiring</b>			
Optimum continuity of service		-	-
Optimum safety (failsafe)		-	-
<b>Mounting</b>			
DIN rail		■	-
Front-panel mount		■	■
<b>Rated operational voltage</b>			
1 DC voltage range from 12 to 48 V		■	-
1 DC voltage range from 24 to 130 V		-	-
5 AC voltage ranges from 12 to 525 V		■	-
4 AC voltage ranges from 48 to 415 V		-	-
1 AC voltage range from 220 to 240 V		-	-
2 AC voltage ranges from 110 to 240 V		-	■
<b>Thresholds</b>			
Fault (I $\Delta$ n)		-	-
Alarm		<b>9 user-selectable thresholds</b> from 0.03 A to 30 A	<b>1 adjustable threshold/channel</b> from 0.03 A to 30 A
Pre-alarm		-	<b>1 adjustable threshold/channel</b> from 0.015 A to 30 A
<b>Time delay</b>			
Fault		-	-
Alarm		<b>9 user-selectable time delay</b> instantaneous to 4.5 s	<b>1 adjustable threshold/channel</b> instantaneous to 5 s
Pre-alarm		-	<b>1 adjustable threshold/channel</b> instantaneous to 5 s
<b>Display and indications</b>			
Voltage presence (LED and/or relay) <sup>(5)</sup>		■	■
Threshold overrun	fault (LED)	-	-
	alarm (LED and relay)	■	■
	pre-alarm (LED and relay)	-	■
Leakage current (digital)		-	■
Settings (digital)		-	■
<b>Test with or without actuation of output contacts</b>			
Local		■	■
Remote (hard-wired)		■	■
Remote (hard-wired for several relays)		■	-
Remote (via communication)		-	■ except RHUs
<b>Communication</b>			
Suitable for supervision		-	■ except RHUs
<b>Characteristics</b>			
		<a href="#">page A-35</a>	<a href="#">page A-35</a>
<b>Sensors</b>			
Schneider Electric A and TOA toroids <sup>(6)</sup>	up to 630 A	■	■
Schneider Electric rectangular sensors	up to 3200 A	■	■

(1) Type A relay up to I $\Delta$ n = 5 A.  
 (2) Relay with output contact that automatically resets after fault clearance.  
 (3) Mandatory with an RMH (multiplexing for the 12 toroids).  
 (4) Mandatory with an RM12T (multiplexing for the 12 toroids).

RMH	RH197M	RH197P
 PE114657-R2.eps  059485-20_SE.eps + (3)	 PB104914-R.eps	 PB10071510_SE.eps
-	■	■
■	■	■
■	■	■
■	-	-
■ 12 measurement channels <sup>(4)</sup>	■ <sup>(5)</sup>	■ <sup>(5)</sup>
-	■	■
-	■	■
-	■	-
■	-	■
-	-	-
-	■	■
-	-	-
-	■	■
-	-	-
■	-	-
-	<b>19 user-selectable thresholds</b> from 0.03 A to 30 A	<b>19 user-selectable thresholds</b> from 0.03 A to 30 A
<b>1 adjustable threshold/channel</b> from 0.03 A to 30 A	Fixed: 50 % IΔn or 100 % IΔn	Fixed: 50 % IΔn or 100 % IΔn
<b>1 adjustable threshold/channel</b> from 0.015 A to 30 A	-	-
-	<b>7 user-selectable time delay</b> instantaneous to 4.5 s	<b>7 user-selectable time delay</b> instantaneous to 4.5 s
<b>1 adjustable threshold/channel</b> instantaneous to 5 s	<b>instantaneous</b>	<b>instantaneous</b>
<b>1 adjustable threshold/channel</b> instantaneous to 5 s	-	-
■	■ <sup>(7)</sup>	■ <sup>(7)</sup>
-	■	■
■	■	■
■	-	-
■	by bargraph	by bargraph
■	-	-
■	<sup>(8)</sup>	-
■	■	■
-	■	■
-	-	-
■	-	-
■	-	-
■	-	-
page A-35	page A-27	page A-27
■	■	■
■	■	■

(5) Depending on the type of wiring (optimum continuity of service or optimum safety).  
 (6) See characteristics page A-36.  
 (7) No voltage presence relay.  
 (8) With actuation of contacts only.

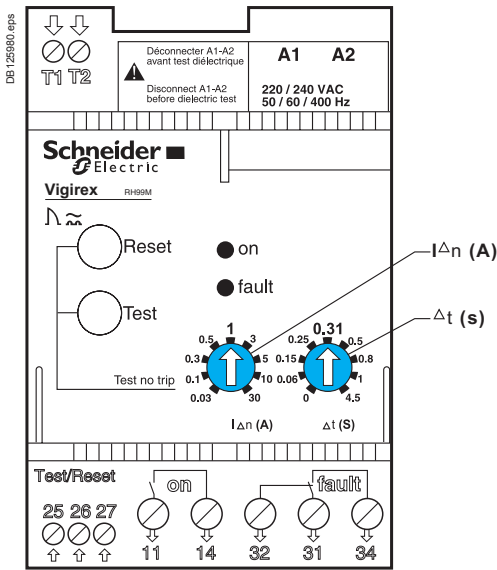

**$I_{\Delta n}$  (A):** residual operating-current setting (the relay operates for a fault current  $\geq I_{\Delta n}$ ). Schneider Electric guarantees non-operation for all fault currents  $< 0.8 I_{\Delta n}$ .

**$\Delta t$  (s):** minimum non-operating time.

## Function

Vigirex relays measure the earth-leakage current in an electrical installation via their associated toroids.

Vigirex relays may be used for:

- residual-current protection (RH10, RH21, RH68, RH86, RH99)
- earth-leakage monitoring (RMH or RH99)
- residual-current protection and earth-leakage monitoring (RH197, RHUs and RHU).

## Residual-current protection relay

Protection relays control the interruption of the supply of power to the monitored systems to protect:

- people against indirect contact and, in addition, against direct contact
- property against fire hazards
- motors.

A relay trips the associated circuit breaker when the test residual operating current  $I_{\Delta n}$  is overrun.

Depending on the relay, the threshold  $I_{\Delta n}$  can be fixed, user-selectable or adjustable and the overrun can be signalled by a digital display of the measured current or a LED.

The leakage current is displayed:

- for the RH197, on a bargraph made up of 4 LEDs indicating levels corresponding to 20, 30, 40 and 50 % of  $I_{\Delta n}$
- for the RHUs and RHU, by digital display of the value of the leakage current.

Circuit breaker tripping can be either instantaneous or delayed. On some relays, it is possible to adjust the time delay.

The protection relays store the residual-current fault in memory. Once the fault has been cleared and the output contact has been manually reset, the relay can be used again.

## Earth-leakage monitoring relays

These relays may be used to monitor drops in electrical insulation due to ageing of cables or extensions in the installation.

Continuous measurement of leakage currents makes it possible to plan preventive maintenance on the faulty circuits. An increase in the leakage currents may lead to a complete shutdown of the installation.

The control signal is issued by the relay when the residual-current operating threshold is overrun.

Depending on the relay, the threshold can be adjustable or user-selectable and the overrun can be signalled via a LED, a bargraph or a digital display of the measured current.

The leakage current is displayed:

- for the RH197, on a bargraph made up of 4 LEDs indicating levels corresponding to 20, 30, 40 and 50 % of  $I_{\Delta n}$
- for the RMH, by digital display of the value of the leakage current.

The control signal can be either instantaneous or delayed. On some relays, it is possible to adjust the time delay.

Earth-leakage monitoring relays do not store the residual-current fault in memory and their output contact is automatically reset when the fault is cleared.

When used in conjunction with a Acti 9 ATm3 or ATm7 auto-reclosing controller (Schneider Electric catalogue numbers 18306 and 18307 respectively), they protect against earth faults due to insulation failures. Typical applications include telephone relay and radio repeater stations. In the event of a transient fault, this system can be used to automatically restore the supply of electrical power to an unattended station, thereby increasing availability and continuity of service.

## Use

Vigirex relays may be used for protection and maintenance at all levels in the installation. Depending on the relays, they may be used in TT, IT or TNS low-voltage AC installations for voltages up to 1000 V and frequencies from 50/60 Hz up to 400 Hz.

Vigirex protection relays are suitable for use with all electrical switchgear devices available on the market.

# General characteristics



The  mark indicates that the product meets both US and Canadian safety requirements.

## Compliance with standards

Vigirex relays are designed to comply with the following standards:

- IEC/EN 60755: general rules for residual-current protection devices
- IEC/EN 60947-2 annex M: low-voltage switchgear and controlgear, part 2 (circuit breakers)
- IEC/EN 60947-5-1: low-voltage switchgear and controlgear, part 5-1 (electromechanical devices)
- IEC/EN 61000-4-2: electrostatic-discharge immunity test
- IEC/EN 61000-4-3: radiated, radio-frequency, electromagnetic-field immunity test
- IEC/EN 61000-4-4: electrical fast transient/burst immunity test
- IEC/EN 61000-4-5: surge immunity test
- IEC/EN 61000-4-6: immunity to conducted disturbances, induced by radio-frequency fields
- CISPR 11: limits and methods of measurement of electromagnetic disturbance characteristics of industrial, scientific and medical (ISM) radiofrequency equipment
- mandatory for CE marking:
  - EN 61000-6-2: immunity to industrial environments
  - EN 50081-1: emissions for commercial and residential environments
- IEC/EN 60664-1: insulation coordination for equipment within low-voltage systems, part 1
- EN 50102: degrees of protection provided by electrical enclosures against external mechanical impact
- IEC 60364 and NF C 15100: installation rules for low-voltage electrical distribution
- UL 1053 and CSA 22.2 No. 144: relays RH10, RH21 and RH99 up to and including 220/240 V comply with these standards.

## Ground fault sensing and relaying equipment UL 1053 and CSA 22.2 No. 144 for North American and North American influenced markets

The basic standard used to investigate products in this category is UL1053 "Ground-Fault Sensing and Relaying Equipment".

The Listing Mark of Underwriters Laboratories Inc. on the products is the only method provided by UL to identify products manufactured under its Listing and Follow Up Service.

The Listing Mark for these products includes the name and/or symbol of Underwriters Laboratories Inc. (as illustrated on the label) together with the word "LISTED", a control number and the following product name "Ground Fault Sensing and Relaying Equipment".

This category covers ground fault current sensing devices, relaying equipment, or combinations of ground fault current sensing devices and relaying equipment which will operate to cause a disconnecting means to function at predetermined values of ground fault current in accordance with the National Electrical Code, ANSI/NFPA70.

The RH99, RH21 and RH10 (M and P) ground fault relays are control powered ground-fault protection devices used to protect an electrical distribution system from ground faults. The relay receives input from sensors, processes the information and if necessary closes output contacts which will cause the associated protection device to trip.

The product is a class 1 combination ground fault current sensor and relay. This equipment is intended to operate devices with shunt trip coils such as moulded case circuit breakers, moulded case switches and the like, which constitute the disconnecting means, by opening all ungrounded conductors at predetermined values of ground fault current.

This product is designed to protect circuits of not more than 600 V AC, 50/60 Hz only.

The relay should be marked with the following electrical ratings, for the two types M and P:

- type M: DIN format (Acti 9 type fast mounting or screw mounting)
- type P: front-panel mount (on panel, door, etc.)
- ratings:
  - fixed  $I\Delta n$  threshold (a number of choices) and no time delay (instantaneous) or
  - selectable  $I\Delta n$  threshold from 0.03 to 30 A and user-selectable time delay from 0 to 4.5 s (see settings on pages [A-26](#) to [A-35](#))
- input voltages:
  - AC: 20 to 24 V AC, 48 V AC, 110 to 130V AC or 220 to 240 V AC, 50/60 Hz, or
  - DC: 12 to 48 V DC
- maximum consumption: 4 W.

PF100435-35\_SE.qps



Front-panel mount device.

PF100435-35\_SE.qps



DIN device.

## Environmental withstand capacity

Vigirex relays meet the environmental requirements contained in the following standards:

- IEC/EN 60068-2-30: damp heat, equipment not operating; relative humidity 95 % at 55 °C (hot and humid climate)
- IEC/EN 60068-2-52: salt mist; KB test severity level 2
- IEC/EN 60068-2-56: damp heat, equipment operating; 48 h, environment category C2.

They may consequently be used in all parts of the world.

## Degree of pollution

Vigirex relays are suitable for operation in the most severe industrial environments. They meet the requirements of degree of pollution 3 as per standard IEC/EN 60664-1 and IEC/EN 60947-1 for low-voltage switchgear and controlgear.

## Ambient temperature

Vigirex relays are designed for use in ambient temperatures from -35 °C to +70 °C. Relays equipped with a digital display (RHU, RHUs, RMH) or bargraph (RH197) are limited to -25 °C to +55 °C.

Start-up should be carried out within the temperature range indicated above.

The temperature range for device storage, in the original packing, is:

- between -55 °C and +85 °C for Vigirex RH10 to RH99
- between -40 °C and +85 °C for Vigirex RH197, RHUs, RHU and RMH.

## Reinforced insulation for direct connection to upstream distribution system

The reinforced insulation of Vigirex relays (overvoltage category IV, the most severe) makes possible, without any additional galvanic isolation:

- direct connection of the relay power supply to the upstream circuit (connection upstream of an LV incoming device such as a Masterpact circuit breaker, for example)
- direct connection to the upstream busbars.

## Insulation class

All Vigirex relays, whether DIN or front-panel mount format, have class II insulated fronts as per standards IEC/EN 60664-1 and NF C 15100.

The communication outputs on the RHU and RMH relays are also class II.

## Degree of protection

According to standards EN 60529 (IP degree of protection) and EN 50102 (IK external mechanical impact protection), the devices are rated IP40 and IK07 for the front face through a door or on a front plate, IP30 for the other faces and IP20 for connections.

Vigirex relays comply with environmental-protection regulations.

DB125591.eps

Déconnecter A1-A2 avant test diélectrique  
Disconnect A1-A2 before dielectric test

A1    A2

220 / 240 V AC  
 50 / 60 / 400 Hz

DB125592.eps

RH..P 380-415 V AC 5100512339

01221      56016      1234607

Information on the case.

### Vibration withstand capacity

Vigirex relays meet the requirements of Veritas and Lloyd's (vibration test from 2 to 13.2 Hz ±1 mm and from 13.2 to 100 Hz – 0.7 g).

### Labels and markings

- UL, CE and as per IEC 60947-2 annex M, EAC marking
- Vigirex relay supply voltage
- Product part number
- The origin (Schneider Electric) and the connection terminals (see pages A-16 to A-22) are indicated on the product.

### Recycling

The packaging is made of recyclable cardboard.  
 Vigirex relays comply with environmental-protection regulations:

- moulded parts are made of thermoplastic materials:
  - 10 % fibreglass reinforced polycarbonate (PC10FV) for DIN cases and front-panel mount cases
- the composition is indicated on the parts
- when disposed of, these materials do not produce polluting substances, even when burned.

### Maximum safety

**Protection of persons against direct contact is ensured by an overall breaking time for the faulty circuit of less than 40 milliseconds:**

Residual-current relays guarantee the protection of persons against direct contact by acting in less than 40 ms when set to a residual operating current of 30 mA and when used with Schneider Electric breakers with a maximum rating of 630 A.  
 The protection of life and property against indirect contact is ensured by optimised measurement of the residual current.

**The tolerances on the protection threshold  $I_{\Delta n}$  are less than those specified in the residual-current protection standard:**

According to standard IEC 60947-2 annex M, instantaneous tripping must take place between 0.5 and 1 x  $I_{\Delta n}$ . Vigirex relays trip between 0.8 and 1 x  $I_{\Delta n}$ , thus increasing immunity to nuisance tripping by 60 %.

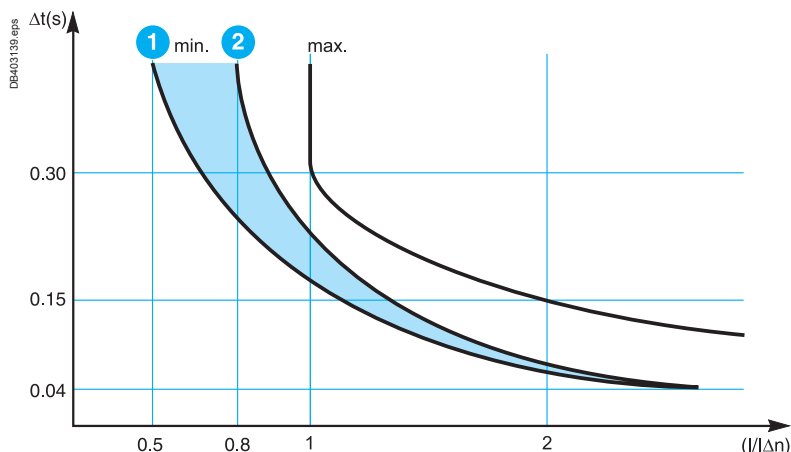

Operating tolerances for the protection threshold  $I_{\Delta n}$ :

- 1 standards.
- 2 Vigirex.
- Gain in immunity to nuisance tripping with Vigirex.

### Inverse-time tripping curve:

When circuits are energised, the inverse-time tripping curve avoids nuisance tripping due to short, transient phase-sequence currents, which are caused by:

- the high transient currents caused by certain loads (e.g. motors, LV/LV transformers, etc.)
- the charging of capacitances between live conductors and earth.

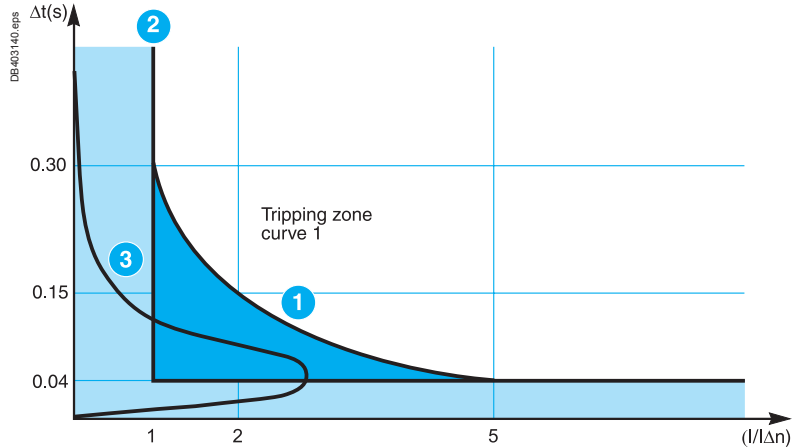

- 1 Curve 1: inverse-time tripping curve as per IEC 60947-2 annex M.
- 2 Curve 2: tripping curve with fixed threshold  $I = I_{\Delta n}$ .
- 3 Curve 3: transient zero phase-sequence current upon load energisation.

Zone of optimised continuity of service due to the inverse-time tripping curve.

Non-tripping zone (curve 2).

### Frequency filtering :

Frequency converters (e.g. variable-speed drives) implementing IGBTs (Insulated Gate Bipolar Transistor) generate significant levels of high-frequency (HF) leakage currents.

During normal operation (no fault), these capacitive HF leakage currents flowing in the installation conductors do not represent a danger for users. In general, residual-current protection relays are sensitive to these HF natural leakage currents.

If an insulation fault occurs downstream of the frequency converter, the fault current comprises a HF-current component. These HF fault currents do not produce the same physiological effects on the human body as 50/60 Hz currents (see IEC 60479).

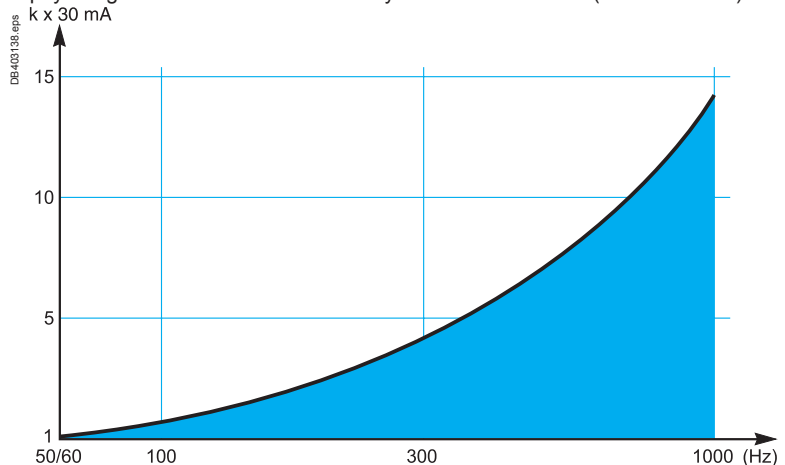

Variation in the ventricular-fibrillation threshold depending on the frequency from 50/60 Hz up to 1000 Hz.

Gain in immunity to nuisance tripping with Vigirex.

**Frequency filtering on the Vigirex range of residual-current protection relays is designed to provide:**

- maximum protection if an insulation fault occurs
- continuity of service that has been specially optimised for this type of load.

**Rms measurements of earth-leakage currents**

Rms measurement of fault currents provides the residual-current protection relays with the means to measure all types of signals and to calculate the weighted true rms value depending on the frequency filtering.

**Rms measurement of earth-leakage currents, frequency filtering, the reduced tolerances on the protection threshold and the inverse-time tripping curve built into the Vigirex relays optimise protection of life and property and enhance the continuity of service.**

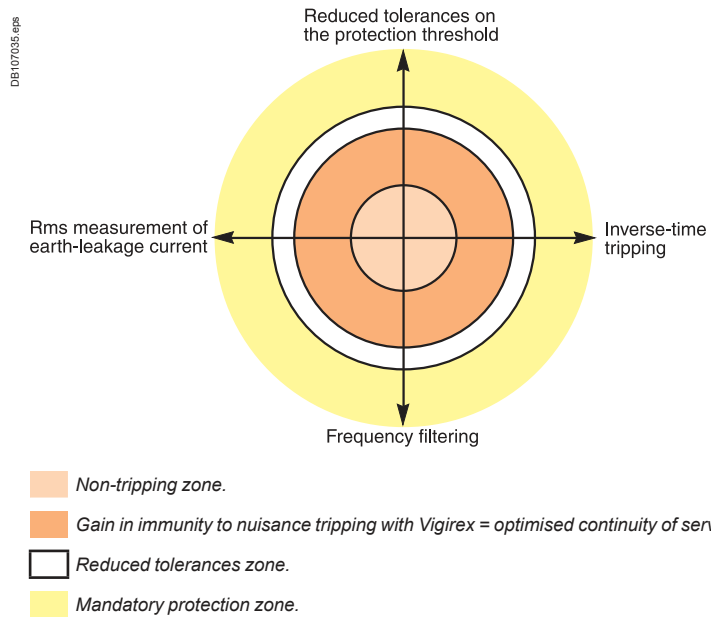

**Continuous self-monitoring of Vigirex relays**

Vigirex relays carry out continuous monitoring of:

- the relay/toroid link (RH10, RH21, RH68, RH86, RH99, RH197, RHU and RMH)
- the link between the RMH relay and the RM12T multiplexer
- the power supply
- the internal electronics.

In the event of problem, the fault or voltage-presence output contact on the protection relays (RH10, RH21, RH68, RH86, RH99, RH197, RHUs and RHU) is actuated. The cause of the fault must be cleared.

**Two wiring techniques for protection relays**

Two different wiring techniques are recommended:

- the first places a premium on safety. The voltage-presence contact on the Vigirex residual-current protection relay (RH10, RH21, RH68, RH86, RH99 or RHUs and RHU) is wired in series with the fault contact. This technique ensures failsafe operation.
- the second technique places a premium on continuity of service if the supply to the residual-current relay is cut.

See the wiring diagrams in chapter D.

## Test and reset

### Test

According to standards IEC 60364 and NF C 15100, a periodic test is required to check correct operation of the residual-current protection system.

The purpose of the test is to check:

- the output contacts:
  - the complete protection system with actuation of the output contacts (this shuts down the installation)
  - the protection system without actuation of the output contacts ("no trip" test) to maintain the installation up and running.
- correct operation of the display (RHUs, RHU, RMH and the RH197 bargraph), the LEDs and the internal electronics.

### Reset

Whatever the test mode, a reset clears the fault stored in memory and resets the LEDs and the relay status condition.

### Test and reset modes

Four possible modes	Actuation of output contacts	
	No <sup>(1)</sup>	Yes
Local via button in front	■	■
Remote 1 relay	■ <sup>(1)</sup>	■ <sup>(1)</sup>
a number of relays	■ <sup>(2)</sup>	■ <sup>(2)</sup>
Via communication	■ (RHU/RMH)	■ (RHU/RMH)

(1) Except for RMH.

(2) Except for the RMH/RH197M.

## Easy switchboard acceptance tests

During acceptance of a switchboard and prior to dielectric testing, isolation of the residual-current relays by disconnecting the supply is mandatory.

Vigirex relays are supplied via a plug-in connector for easy and secure connection and disconnection.

All connections for the front-panel mount relays of the Vigirex range use plug-in connectors.

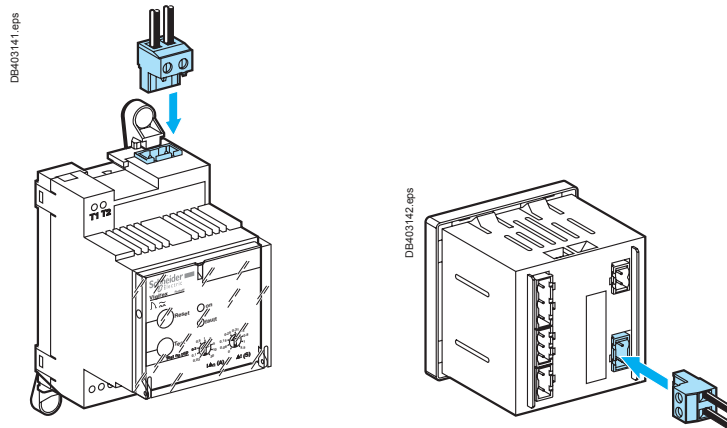

Supply connections for the DIN and front-panel mount formats.

## Formats for all installation systems

Vigirex relays are available in two formats:

- front-panel mount format 72 x 72 mm (RH10, RH21, RH86P, RH99, RH197P, RHUs, RHU, RMH)
- DIN format (RH10, RH21, RH68M, RH86M, RH99, RH197M).

On the DIN-format relays, it is possible to simply clip in:

- the toroids  $\varnothing$  30 mm and  $\varnothing$  50 mm
- three mounting lugs for relay installation on mounting plates in control cabinets.

Installation system	Suitable format
Main LV switchboard	Front-panel mount
Power distribution switchboard: <ul style="list-style-type: none"> <li>■ instrumentation zone</li> <li>■ modular-device zone</li> </ul>	Front-panel mount DIN



DIN device with mounting lugs secured to a mounting plate.

## Formats for all installation systems (cont.)

PB100444-47\_SE.eps



DIN device.

PB100435-53\_SE.eps



DIN device with clip-in toroid.

PB11382\_R5.eps



Front-panel mount device.

PB100431-36\_SE.eps



Lead-sealable cover.

PB111556\_23.eps



Automatic control panel or machine panel.

PD380038-27.eps



Power distribution switchboard.

PB105109.eps

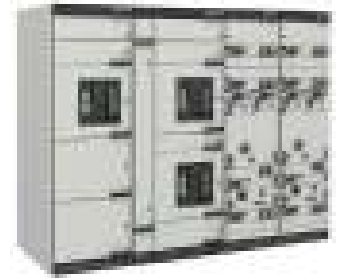

Main LV switchboard.

054504-89.eps



Motor Control Centre (MCC).

### Covers

All Vigirex relays are equipped with lead-sealable covers to block access to settings while maintaining access to the device test and reset buttons.

# Discrimination between residual-current devices

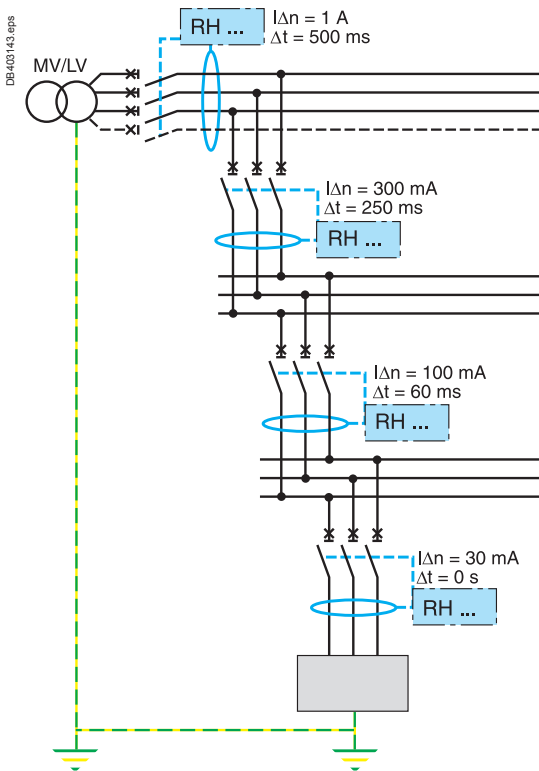

It is possible to divide the installation into a number of groups of circuits and to protect each group using the suitable residual-current device. The many fault, alarm and pre-alarm settings and time delays available in the Vigirex range makes it easy to integrate the residual-current relays at all levels in the electrical installation. Coordination between the upstream and downstream devices in an installation makes it possible to cut the supply (by the protection relay) exclusively in the part of the installation where the fault occurred.

## Implementing discrimination

Discrimination between upstream and downstream residual-current devices is necessarily of the current and time type. It is ensured by correctly adjusting:

- the operating-current settings
- the non-operating and overall breaking times.

The following general discrimination rules ensure correct operation:

- in terms of the current, the setting for the upstream device must be double that of the downstream device (in accordance with the standardised rules for the operating / non-operating currents)
  - in terms of the time, the non-operating time (time delay) for the upstream device must be greater than the total time (the intentional residual-current device delay and the breaking time of the breaking device) for the downstream device
- These two conditions are summed up here:
- upstream  $I\Delta n \geq 2 \times$  downstream  $I\Delta n$
  - upstream non-operating time  $\Delta T \geq$  downstream total time  $\Delta T$ .

**Note:** a residual-current device does not limit the fault current. That is why current discrimination alone is not possible.

The time/current curves indicate the operating-current values of the Vigirex devices depending on their standardised characteristics. When superimposed, the curves indicate the protection settings required to ensure total discrimination (see the curves pages E-43 to E-46).

**The Vigirex devices, combined with Schneider Electric breaking devices (switches, circuit breakers), have successive operating-current and time-delay settings that enhance the discrimination rules mentioned above.**

### Discrimination rules

System (Schneider Electric breaking device + RCD)		Setting	
Upstream	Downstream	Ratio $I\Delta n$	Time delay
Vigirex	Schneider RCD	1.5	1 setting apart, except <sup>(1)</sup>
Schneider RCD	Vigirex	2	1 setting apart, except <sup>(1)</sup>
Vigirex	Vigirex	1.25	1 setting apart <sup>(1)</sup>

<sup>(1)</sup> A difference of two settings is required for the 0.25 s setting (i.e. the 0.5 s and the 0.25 s settings).

**Note:** for further information, see chapter E.

The Schneider Electric residual-current protection ranges (earth-leakage protection function on Masterpact circuit breaker control units, Vigicomact, Acti 9 RCDs, etc.) are internally consistent and designed for combined use to ensure discrimination for insulation faults.

## Electromagnetic disturbances

Vigirex relays are immune to:

- overvoltages produced by switching (e.g. lighting circuits)
- overvoltages produced by atmospheric disturbances
- radio-frequency waves emitted by devices such as mobile telephones, radio transmitters, walky-talkies, radar, etc.
- electrostatic discharges produced directly by users.

To guarantee immunity, Vigirex relays are tested in compliance with the following standards:

- IEC/EN 60947-2: low-voltage switchgear and controlgear, part 2 circuit breakers)
- IEC/EN 61000-4-1: overview of the IEC/EN 61000-4 series
- IEC/EN 61000-4-2: electrostatic-discharge immunity test
- IEC/EN 61000-4-3: radiated, radio-frequency, electromagnetic-field immunity test
- IEC/EN 61000-4-4: electrical fast transient/burst immunity test
- IEC/EN 61000-4-5: surge immunity test
- IEC/EN 61000-4-6: immunity to conducted disturbances, induced by radio-frequency fields
- CISPR 11: limits and methods of measurement of electromagnetic disturbance characteristics of industrial, scientific and medical (ISM) radiofrequency equipment.

The high immunity levels of Vigirex relays ensure optimum safety without nuisance tripping.

## Behaviour during micro-outages in the auxiliary supply

Vigirex relays are not affected by micro-outages lasting less than 60 ms.

The maximum break time during micro-outages complies with standard IEC/EN 60947-2 annex M.

# Description

## RH10M, RH21M, RH68M, RH86M and RH99M relays

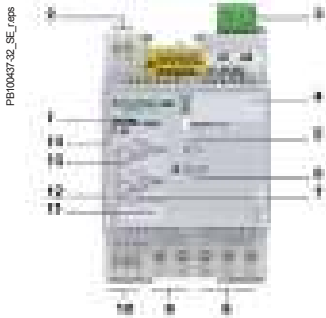

RH10M

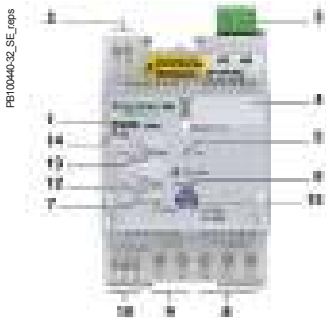

RH21M.

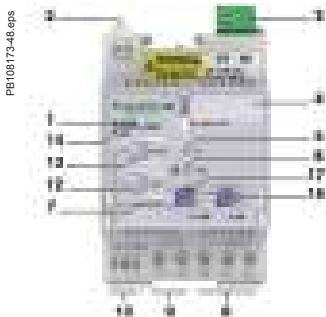

RH68M.

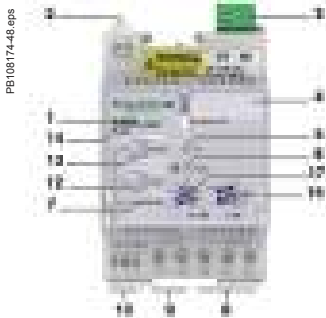

RH86M.

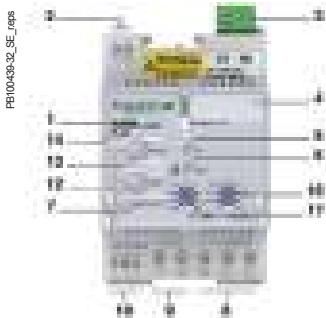

RH99M.

### Relay marking

- 1 Type of relay.
- 4 Customer marking zone (circuit identification).
- 11 Sensitivity (RH10M):  $I\Delta n$  (A) /  $\Delta t$  (s).
- 14 Relay class.

### Controls

- 7 Press and hold the Reset button, then press the Test button to test the device without actuating the output contacts.
- 12 Test button.
- 13 Reset button.

### Indications

- 5 Green voltage-presence LED (on).
- 6 Red insulation-fault LED (fault).

LED status		Meaning
on	fault	
●	●	Normal operation
●	●	Fault current detected
●	● ● ●	Relay/sensor link fault
●	●	No voltage or device not in service
●	●	Malfuction detected

Key:

- off
- (●) green (or red)
- ● ● flashing.

### Settings

- 15 Threshold and time-delay selectors (RH21):  $I\Delta n$  (A) /  $\Delta t$  (s)  
Three possible settings:
  - 0.03 A sensitivity, instantaneous
  - 0.3 A sensitivity, instantaneous
  - 0.3 A sensitivity, 0.06 s delay
- 16 Time-delay selector (RH99):  $\Delta t$  (s)  
Nine possible settings (instantaneous – 0.06 s – 0.15 s – 0.25 s – 0.31 s – 0.5 s – 0.8 s – 1 s – 4.5 s).
- 17 Threshold selector (RH99):  $I\Delta n$  (A)  
Nine possible settings (0.03 A – 0.1 A – 0.3 A – 0.5 A – 1 A – 3 A – 5 A – 10 A – 30 A).

### Connection

- 2 Sensor.
- 3 Plug-in supply.
- 8 Fault contact.
- 9 Voltage-presence contact.
- 10 Remote reset/test.

# RH197M relays

PB104914-501.eps



## Relay marking

- 1 Type of relay.
- 2 Customer marking zone (circuit identification).
- 3 Relay class.

## Controls

- 9 Press and hold the Reset button, then press the Test button to test the device without actuating the output contacts.
- 10 Test button.
- 11 Reset button.

## Indications

- 12 Green voltage-presence LED (on).
- 13 Yellow alarm LEDs I $\Delta$ N: 20, 30, 40 and 50 %.
- 14 Red insulation-fault LED (fault).

LED status		Meaning
on	fault	
●	●	Normal operation
●	●	Fault current detected
●	● ● ●	Faulty sensor/relay link
●	●	No power or device not working

Key:

- off
- green
- ● ● flashing.

## Settings

### 15 Dip switch:

- Ne/Nd switch used to select the operating mode:
  - failsafe mode: position Ne
  - non-failsafe mode: position Nd
- "Auto/Manual" switch used to select fault relay reset mode
  - in "Manual" position: latching relay requiring the Reset button to be pressed after fault clearing
  - in "Auto" position: automatic reset of fault relay (after fault clearing)
- 10 resets are possible according to the following algorithm:
  - 1st reset: 30 s after the fault
  - 2nd reset: 1 min. after the fault
  - 3rd reset: 2 min. after the fault
  - 4th reset: 4 min. after the fault
  - 5th reset: 8 min. after the fault
  - 6th reset: 16 min. after the fault
  - 7th reset: 32 min. after the fault
  - 8th reset: 64 min. after the fault
  - 9th reset: 128 min. after the fault
  - 10th reset: 256 min. after the fault

The trip counter is reset 30 minutes after fault relay reset.

- AI 50 % - 100 % (setting by Dip switch at 50 % of I $\Delta$ n or 100 % of I $\Delta$ n).
- Selector gain for I $\Delta$ n.

### 16 Threshold I $\Delta$ n (A): 19 possible settings (0.03 A – 0.05 A – 0.075 A – 0.1 A – 0.15 A – 0.2 A – 0.3 A – 0.5 A – 0.75 A – 1 A – 1.5 A – 2 A – 3 A – 5 A – 7.5 A – 10 A – 15 A – 20 A – 30 A).

Time-delay selector  $\Delta t$  (s): 7 possible settings (instantaneous – 0.06 s – 0.15 s – 0.31 s – 0.5 s – 1 s – 4.5 s).

## Connection

- 4 Plug-in supply.
- 5 Fault contact.
- 6 Alarm contact
- 7 Remote reset/test.
- 8 Sensor.

DB403204.eps

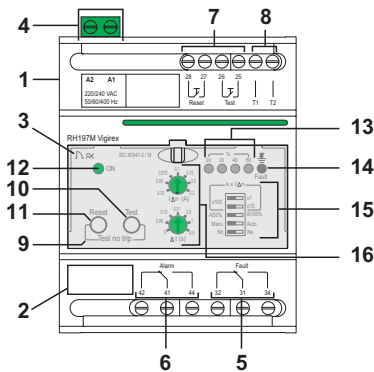

RH197M.

# Description

## RH10P, RH21P, RH86P and RH99P relays



RH10P



RH21P



RH86P



RH99P

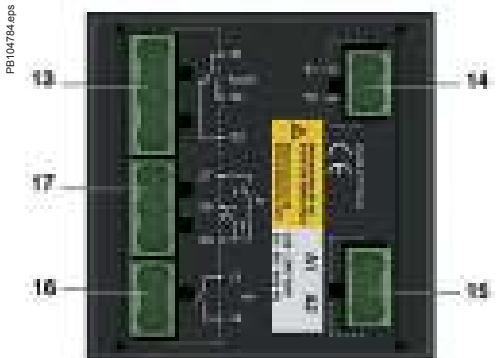

Connections on the back of the relay.

### Relay marking

- 1 Type of relay.
- 4 Customer marking zone (circuit identification).
- 8 Sensitivity (RH10P):  $I\Delta n$  (A) /  $\Delta t$  (s).
- 9 Relay class.

### Controls

- 5 Test button.
- 6 Reset button.
- 7 Press and hold the Reset button, then press the Test button to test the device without actuating the output contacts.

### Indications

- 2 Green voltage-presence LED (on).
- 3 Red insulation-fault LED (fault).

LED status		Meaning
on	fault	
●	●	Normal operation
●	●	Fault current detected
●	● ● ●	Relay/sensor link fault
●	●	No voltage or device not in service
●	●	Malfunction detected

Key:

- off
- (●) green (or red)
- ● ● flashing.

### Settings

- 10 Threshold and time-delay selectors (RH21):  $I\Delta n$  (A) /  $\Delta t$  (s)  
Three possible settings:
  - 0.03 A sensitivity, instantaneous
  - 0.3 A sensitivity, instantaneous
  - 0.3 A sensitivity, 0.06 s delay
- 11 Time-delay selector (RH99):  $\Delta t$  (s)  
Nine possible settings (instantaneous – 0.06 s – 0.15 s – 0.25 s – 0.31 s – 0.5 s – 0.8 s – 1 s – 4.5 s).
- 12 Threshold selector (RH99):  $I\Delta n$  (A)  
Nine possible settings (0.03 A – 0.1 A – 0.3 A – 0.5 A – 1 A – 3 A – 5 A – 10 A – 30 A).

### Connection

All connections for front-panel mount relays are of the plug-in type.

- 13 Fault contact.
- 14 Sensor.
- 15 Plug-in supply.
- 16 Voltage-presence contact.
- 17 Remote reset/test.

# RH197P relays



RH197P



Connections on the back of the relay.

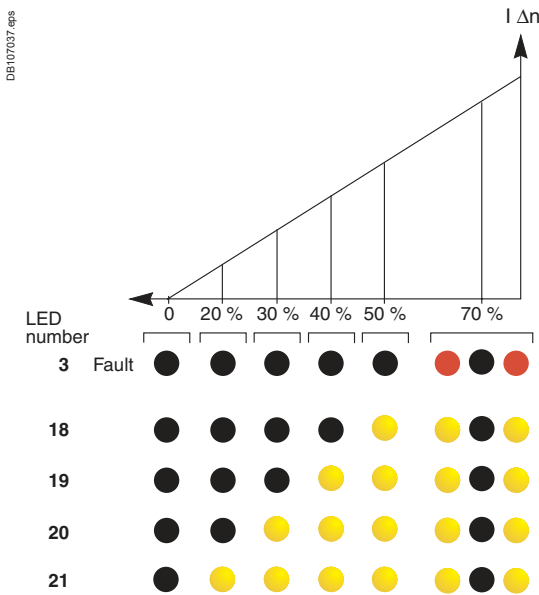

Status of the indication LEDs according to the measured fault current (%  $I_{\Delta n}$ ).

## Relay marking

- 1 Type of relay.
- 4 Customer marking zone (circuit identification).
- 9 Relay class.

## Controls

- 5 Test button.
- 6 Reset button.

## Indications

- 2 Green voltage-presence LED (on).
- 3 Red insulation-fault LED (fault).
- 18, 19, 20, 21 yellow alarm LEDs for  $I_{\Delta n}$  reaching 50, 40, 30 and 20 % (respectively) of  $I_{\Delta n}$  setting. When 70 % of the  $I_{\Delta n}$  setting is reached, all the yellow alarm LEDs (18, 19, 20, 21) and the red insulation-fault LED flash.

LED status		Meaning
on	fault	
●	●	Normal operation
●	●	Fault current detected
●	●	Relay/sensor link fault
●	●●●	No voltage or device not in service

Key:

- off
- flashing
- (●) green (or red)

## Settings





- 11 Time-delay selector:
    - 7 possible settings (instantaneous – 0.06 s – 0.15 s – 0.31 s – 0.5 s – 1 s – 4.5 s).
  - 12 Threshold selector:
    - 19 possible settings (0.03 A – 0.05 A – 0.075 A – 0.1 A – 0.15 A – 0.2 A – 0.3 A – 0.5 A – 0.75 A – 1 A – 1.5 A – 2 A – 3 A – 5 A – 7.5 A – 10 A – 15 A – 20 A – 30 A).
  - 24 Ne/Nd switch used to select the operating mode:
    - failsafe mode: position Ne
    - non-failsafe mode: position Nd
  - 25 "Auto/Manual" switch used to select fault relay reset mode
    - in "Manual" position: latching relay requiring the Reset button to be pressed after fault clearing
    - in "Auto" position: automatic reset of fault relay (after fault clearing)
    - 10 resets are possible according to the following algorithm:
      - 1st reset: 30 s after the fault
      - 2nd reset: 1 min. after the fault
      - 3rd reset: 2 min. after the fault
      - 4th reset: 4 min. after the fault
      - 5th reset: 8 min. after the fault
      - 6th reset: 16 min. after the fault
      - 7th reset: 32 min. after the fault
      - 8th reset: 64 min. after the fault
      - 9th reset: 128 min. after the fault
      - 10th reset: 256 min. after the fault
- The trip counter is reset 30 minutes after fault relay reset.

## Connection

All connections for front-panel mount relays are of the plug-in type.

- 13 Plug-in supply.
- 14 Fault contact.
- 15 Alarm contact.
- 16 Remote reset/test.
- 17 Sensor.

22-23 Gain selector for threshold selector 12 ( $I_{\Delta n}$ ):  
The  $I_{\Delta n} = 0.030$  A setting is not modified by the gain selector.

Position of 22 and 23	Actual trip threshold $I_{\Delta n}$ (A)
 x100 x10	$I_{\Delta n}$ (A)
 x100 x10	10 $I_{\Delta n}$ (A)
 x100 x10	100 $I_{\Delta n}$ (A)
 x100 x10	$I_{\Delta n}$ (A)

# Description

## RHUs and RHU relays

### Functions

The Vigirex RHU is used together with a toroid (open or closed) or a rectangular sensor.

Vigirex RHU:

- Measures the earth-leakage current detected by the toroid.
- Displays the earth-leakage current.
- Trips the installation protection circuit breaker through an MN or MX release if the earth-leakage current exceeds the threshold  $I\Delta N$  for a time greater than the delay  $\Delta t$ .
- Activates a pre-alarm when the earth-leakage current on a circuit exceeds pre-alarm threshold.
- Activates an alarm when the earth-leakage current on a circuit exceeds alarm threshold.
- Integrates perfectly in the Smart Panel architecture system by communicating with the Modbus communication (Except RHUs which is without communication).

### HMI Description and Navigation Principles

#### Overview

Legend	Display	Description
1	LCD screen	Displays the parameter settings and the measurement values.
2	Status LEDs	Indicates power on, status of alarm, pre-alarm, and communication.
3	Navigation buttons	Allows to navigate

#### Status LED

Status LED	Color	Description
ON	Green	Is switched on when the Vigirex relay is powered.
Alarm	Red	Is switched on when an alarm is active.
Pre-alarm	Orange	Is switched on when a pre-alarm is active.
COM	Green	Blinks when the Vigirex relay detects or sends a Modbus frame.

#### Navigation Buttons

Button	Icon	Description
Validation	OK	Allows to: <ul style="list-style-type: none"> <li>■ Modify parameter.</li> <li>■ Select an item.</li> <li>■ validate current setting.</li> <li>■ start test mode.</li> <li>■ exit test mode at the end of the test.</li> </ul>
Down	Down Arrow	Allows to move to: <ul style="list-style-type: none"> <li>■ next screen.</li> <li>■ next menu item.</li> </ul> Allows to decrease the numerical value while setting the parameters.
Up	Up Arrow	Allows to move to: <ul style="list-style-type: none"> <li>■ previous screen.</li> <li>■ previous menu item.</li> </ul> Allows to increase the numerical value while setting the parameters.
Home	Home Icon	<ul style="list-style-type: none"> <li>■ Allows to access the home menu.</li> </ul>

### Connection

- 4 Terminal block to connect the pre-alarm contact and the alarm contact
- 5 Terminal block to connect the toroid and the Test/Reset contacts
- 6 Terminal block to connect the power supply and voltage presence contact
- 7 Modbus SL port

DB419082.eps

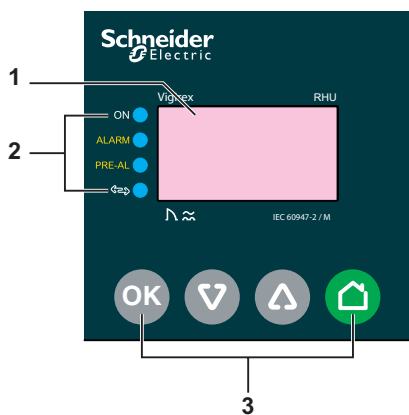

DB419277.eps



DB419583.eps

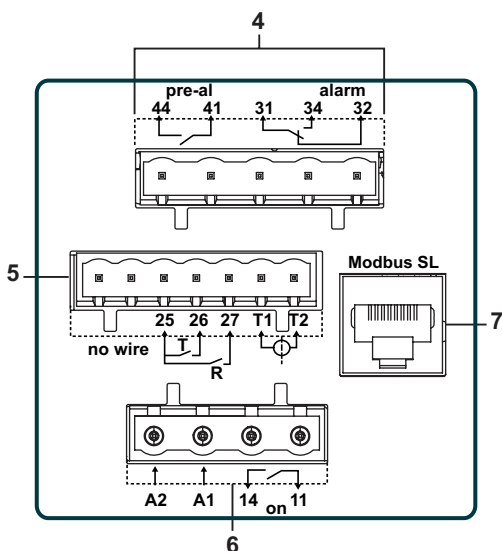

# RMH relay and RM12T multiplexer

## Functions

The Vigirex RMH is used together with a Vigirex RM12T and toroid (open or closed) or a rectangular sensor.

Vigirex RMH:

- Measures the earth-leakage current detected by the toroids (12 maximum).
- Displays the earth-leakage current.
- Activates a pre-alarm when the earth-leakage current on a circuit exceeds its pre-alarm threshold.
- Activates an alarm when the earth-leakage current on a circuit exceeds its alarm threshold.
- Integrates perfectly in the Smart Panel architecture system by communicating with the Modbus communication.

## Alarm Detection

An alarm is active when the measured earth-leakage current is greater than the set alarm threshold (I alarm) on at least one toroid for a period of time greater than the set alarm delay (t alarm in milliseconds or seconds) for that particular toroid.

When an alarm is active:

- the **ALARM** and **PRE-AL** LED are switched on.
- When only one alarm is detected, the **Metering** screen of the corresponding toroid is displayed, and the earth-leakage current value blinks.
- When more than one alarm are detected, the **Alarm** screen is displayed.

## Pre-Alarm Detection

A pre-alarm is active when the measured earth-leakage current is greater than the set pre-alarm threshold on at least one channel for a period of time greater than the set pre-alarm trip delay (t pre-alarm in milliseconds or seconds) for that particular toroid.

When a pre-alarm is active:

- the **PRE-AL** LED is switched on and the displayed value blinks.
- When only one pre-alarm is detected, the Metering screen of the corresponding toroid is displayed, and the earth-leakage current value blinks.
- When more than one alarm are detected, the Pre-alarm screen is displayed.

## HMI Description and Navigation Principles

### Overview

Legend	Display	Description
1	LCD screen	Displays the parameter settings and the measurement values.
2	Status LEDs	Indicates power on, status of alarm, pre-alarm, and communication
3	Navigation buttons	Allows to navigate

### Status LED

Status LED	Color	Description
ON	Green	Is switched on when the Vigirex relay is powered.
Alarm	Red	Is switched on when an alarm is active.
Pre-alarm	Orange	Is switched on when a pre-alarm is active.
COM	Green	Blinks when the Vigirex relay detects or sends a Modbus frame.

### Navigation Buttons

Button	Icon	Description
Validation		Allows to: <ul style="list-style-type: none"> <li>■ select an item.</li> <li>■ modify parameter.</li> <li>■ validate current setting.</li> <li>■ start test mode.</li> <li>■ exit test mode at the end of the test.</li> </ul>
Down		Allows to move to: <ul style="list-style-type: none"> <li>■ next screen.</li> <li>■ next menu item.</li> </ul> Allows you to decrease the numerical value.
Up		Allows to move to: <ul style="list-style-type: none"> <li>■ previous screen.</li> <li>■ previous menu item.</li> </ul> Allows to increase the numerical value.
Home		Allows to access the home menu.

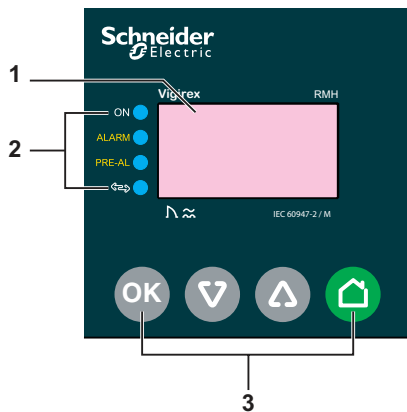

DB419083.eps

DB419277.eps

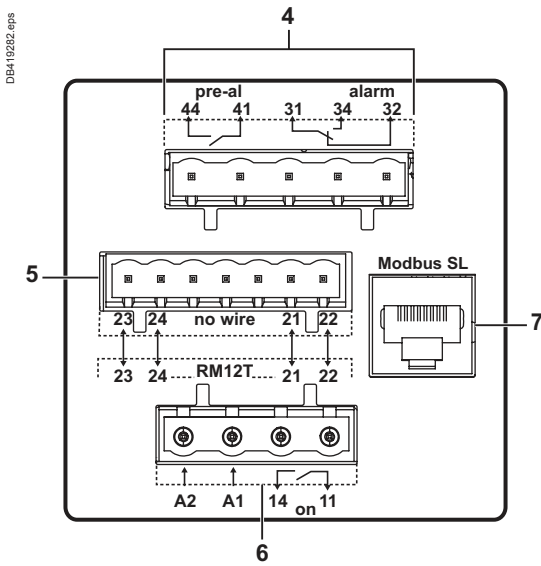

Connections on the back side of the RMH.

### Connection

- 4 Terminal block to connect the pre-alarm contact and the alarm contact.
- 5 Terminal block to connect the RM12T multiplexer.
- 6 Terminal block to connect the power supply and voltage presence contact.
- 7 Modbus SL port.



Front of RM12T multiplexer.

### RM12T multiplexer connection

- 20 Sensors (12 measurement channels).
- 21 RMH relay.
- 22 Supply.

# RHU and RMH communication

RHU and RMH are equipped for Modbus communication serial in line.

## Overview of functions

Communication provides a means to identify the device, indicate status conditions, control the device, set the protection and alarms and analyse the instantaneous and maximum residual currents to assist operation and maintenance. It involves the transmission of data (bits or words) in real time, periodically or on request.

*Note: a complete description of the communication system and the protocol are provided in the RHU or RMH user guide.*

Remote control		RHU	RMH
<b>Device identification</b>			
Address set		■	■
Type of device		RHU	RMH
<b>Status indications</b>			
RHU alarm / RMH pre-alarm		■	■
RHU fault / RMH alarm		■	■
<b>Controls</b>			
Test with actuation of the output contacts		■	■
Test without actuation of the output contacts		■	■
Output-contact reset following a fault		■	-
Alarm-display memory reset		-	■
<b>Protection settings</b>			
I pre-alarm threshold		-	■
Pre-alarm time delay		-	■
Alarm threshold		■	■
Alarm time delay		■	■
Alarm reset		■	-
Toroid selection		-	■
<b>Operating and maintenance aids</b>			
Measurements	Alarm threshold value	■	■
	Mesured earth leakage as percentage of alarm threshold value	■	■
	Maximum leakage current	■	■
Fault readings	Malfunction detected	■	■
	RMH/RM12T link fault	-	■
	Saturation of fault-current measurements	■	■
	Sensor link fault	■	■



# Sensors

059470-28\_SE.eps



A type closed toroid: SA200.

PB114665-R4.eps



TOA80 split toroid.

059476-49\_SE.eps



Rectangular sensor.

## Compatibility with toroids

Vigirex RH10, RH21, RH68, RH86, RH99, RH197, RHUs, RHU and RMH relays may be used with the following sensors:

- closed or split toroids (OA / TOA type)
- E type toroids (existing installations):
  - TE (Ø30 mm) and PE (Ø50 mm): total compatibility
  - IE (Ø80 mm), ME (Ø120 mm) and SE (Ø200 mm): the Vigirex sensitivity must be set to a value  $\geq 300$  mA.

## Adaptation to installations

- Closed toroids are suitable for new installations up to 630 A. Certain toroids may be mounted on DIN rails, plates or brackets, clipped onto the Vigirex relay or tied to the cables (see [page A-24](#))
- New split toroids (from 80 to 120 mm) facilitate installation in existing systems up to 250 A. Thank to a trigger, it's very useful to open the toroid, put the cables and re-close the toroid. These toroids could be installed directly on plates or as a modular product through a specific part.
- Rectangular sensors are for busbars in installations with currents  $\leq 3200$  A.

## Compatibility with rectangular sensors

The RH10, RH21, RH68, RH86, RH99, RH197, RHUs, RHU and RMH relays may be used with rectangular sensors (L type) 280 x 115 mm and 470 x 160 mm. The Vigirex sensitivity must be set to  $\geq 300$  mA.

## Withstand capacity for high residual-current faults

Tests guarantee accurate measurements after a high phase-sequence current flowing through the toroid during a short-circuit between a phase and the PE conductor.

## Temperature ranges

- The temperature range for toroid operation is:
  - OA / TOA type toroids:  $-35^{\circ}\text{C} / +70^{\circ}\text{C}$
  - rectangular sensors:  $-35^{\circ}\text{C} / +80^{\circ}\text{C}$
- The temperature range for toroid storage is:
  - OA / TOA type toroids:  $-55^{\circ}\text{C} / +85^{\circ}\text{C}$
  - L type rectangular sensors:  $-55^{\circ}\text{C} / +100^{\circ}\text{C}$ .

# Characteristics

## Protection relays with output contact requiring local manual reset after a fault

Vigirex relays		RH10	RH21
<b>General characteristics</b>			
Monitored distribution system: LV AC / System voltage		50/60/400 Hz ≤ 1000 V	50/60/400 Hz ≤ 1000 V
System earthing arrangement		TT, TNS, IT	TT, TNS, IT
A, AC type class as per IEC 60947-2 appendix M <sup>(1)</sup>		■	■
Operating-temperature range		-35 °C / +70 °C	-35 °C / +70 °C
Storage-temperature range		-55 °C / +85 °C	-55 °C / +85 °C
<b>Electrical characteristics as per IEC 60755 and EN 60755, IEC 60947-2 and EN 60947-2, UL 1053 and CSA C22.2 N° 144 for RH10 to 99 with U<sub>e</sub> ≤ 220 V</b>			
Power supply:	12 to 24 V AC - 12 to 48 V DC	50/60 Hz / DC	■
rated operational voltage U <sub>e</sub>	48 V AC - 24 to 130 V DC	50/60 Hz / DC	-
	48 V AC	50/60 Hz	■
	110 to 130 V AC	50/60 Hz	■
	220 to 240 V AC	50/60/400 Hz	■
	380 to 415 V AC	50/60 Hz	■
	440 to 525 V AC	50/60 Hz	■
Operational voltage tolerances	U <sub>e</sub> : 12 to 24 V AC - 12 to 48 V DC	55 % to 120 % U <sub>e</sub> <sup>(2)</sup>	55 % to 120 % U <sub>e</sub> <sup>(2)</sup>
	U <sub>e</sub> : 48 V AC - 24 to 130 V DC	-	-
	U <sub>e</sub> : 48 to 415 V	55 % to 110 % U <sub>e</sub>	55 % to 110 % U <sub>e</sub>
	U <sub>e</sub> : 110 to 415 V	-	-
	U <sub>e</sub> > 415 V	70 % to 110 % U <sub>e</sub>	70 % to 110 % U <sub>e</sub>
Overvoltage category		4	4
Rated impulse withstand voltage up to U <sub>e</sub> = 525 V AC	U <sub>imp</sub> (kV)	8	8
Maximum consumption	AC	4 VA	4 VA
	DC	4 W	4 W
Insensitive to micro-outages ≤ 60 ms		■	■
Maximum break time on toroid failure (as per standard IEC 60947-2)		■	■
Leakage-current measurements	Measurement range	from 15 mA to 60 A	from 15 mA to 60 A
	Measurement accuracy	±7 %	±7 %
	Display refresh time	-	-
Fault current detection	Threshold I <sub>Δn</sub>	1 fixed threshold 0.03 A - 0.05 A - 0.1 A - 0.15 A 0.25 A - 0.3 A - 0.5 A - 1 A	2 user-selectable thresholds 0.03 A or 0.3 A
	Fault-current detection range	80 % I <sub>Δn</sub> to 100 % I <sub>Δn</sub>	80 % I <sub>Δn</sub> to 100 % I <sub>Δn</sub>
	Time delay Δt	instantaneous	instantaneous for I <sub>Δn</sub> = 0,03 A 1 user-selectable time delay instantaneous or 0.06 s for I <sub>Δn</sub> = 0.3 A
	Δt settings (s)	0	0   0.06
	Maximum non-operating time at 2 I <sub>Δn</sub> (s)	-	-   0.06
	Maximum operating time at 5 I <sub>Δn</sub> (s) (residual-current relay alone)	0.015	0.015   0.13
	Maximum total time at 5 I <sub>Δn</sub> <sup>(6)</sup> (s)	0.04	0.04   0.15
	Setting	none	selector
	Output contact	changeover with latching	changeover with latching
Alarm	I alarm threshold	-	-
	Alarm-current detection range	-	-
	Time delay Δt alarm	-	-
	Δt alarm settings	-	-
	Maximum non-detection time at 2 I alarm	-	-
	Maximum detection time at 5 I alarm	-	-
	Setting	-	-
	Output contact	-	-
	Hysteresis	-	-
Test with or without actuation of the output contacts and output-contact reset following a fault	Local	■	■
	Remote (hard-wired) (10 m maximum)	■	■
	Remote (hard-wired for several relays) (10 m maximum)	■	■
	Remote (via communication)	-	-
Self-monitoring	Relay/sensor link	continuous	continuous
	Power supply	continuous	continuous
	Electronics	continuous	continuous

(1) Type A relays up to 5 A.  
 (2) 80 % to 120 % U<sub>e</sub> if U<sub>e</sub> < 20 V.  
 (3) 80 % to 110 % U<sub>e</sub> if U<sub>e</sub> < 28 V.

(4) 85 % during energisation.  
 (5) < 10 % of I<sub>Δn</sub>: display = 0 and > 200 % of I<sub>Δn</sub>: display = SAT.

RH68	RH86	RH99
50/60/400 Hz ≤ 1000 V	50/60/400 Hz ≤ 1000 V	50/60/400 Hz ≤ 1000 V
TT, TNS, IT	TT, TNS, IT	TT, TNS, IT
■	■	■
-35 °C / +70 °C	-35 °C / +70 °C	-35 °C / +70 °C
-55 °C / +85 °C	-55 °C / +85 °C	-55 °C / +85 °C
-	-	■
-	-	-
-	-	■
-	-	■
■	■	■
-	-	■
-	-	■
-	-	55 % to 120 % Ue <sup>(2)</sup>
-	-	-
55 % to 110 % Ue	55 % to 110 % Ue	55 % to 110 % Ue
-	-	-
-	-	70 % to 110 % Ue
4	4	4
8	8	8
4 VA	4 VA	4 VA
4 W	4 W	4 W
■	■	■
■	■	■
from 15 mA to 60 A	from 15 mA to 60 A	from 15 mA to 60 A
±7 %	±7 %	±7 %
-	-	-
6 user-selectable thresholds 0.03 A - 0.1 A - 0.3 A - 0.5 A - 1 A - 3 A	8 user-selectable thresholds 0.03 A - 0.1 A - 0.3 A - 0.5 A - 1 A - 3 A - 5 A - 10 A	9 user-selectable thresholds 0.03 A - 0.1 A - 0.3 A - 0.5 A - 1 A - 3 A - 5 A - 10 A - 30 A
80 % I <sub>Δn</sub> to 100 % I <sub>Δn</sub> instantaneous for I <sub>Δn</sub> = 0.03 A 8 user-selectable time delays instantaneous to 1 s	80 % I <sub>Δn</sub> to 100 % I <sub>Δn</sub> instantaneous for I <sub>Δn</sub> = 0.03 A 6 user-selectable time delays instantaneous to 0.5 s	80 % I <sub>Δn</sub> to 100 % I <sub>Δn</sub> instantaneous for I <sub>Δn</sub> = 0.03 A 9 user-selectable time delays instantaneous to 4.5 s
0   0.06   0.15   0.25   0.31   0.5   0.8   1	0   0.06   0.15   0.25   0.31   0.5	0   0.06   0.15   0.25   0.31   0.5   0.8   1   4.5
-   0.06   0.15   0.25   0.31   0.5   0.8   1	-   0.06   0.15   0.25   0.31   0.5	-   0.06   0.15   0.25   0.31   0.5   0.8   1   4.5
0.015   0.13   0.23   0.32   0.39   0.58   0.88   1.08	0.015   0.13   0.23   0.32   0.39   0.58	0.015   0.13   0.23   0.32   0.39   0.58   0.88   1.08   4.58
0.04   0.15   0.25   0.34   0.41   0.6   0.9   1.1	0.04   0.15   0.25   0.34   0.41   0.6	0.04   0.15   0.25   0.34   0.41   0.6   0.9   1.1   4.6
selector	selector	selector
changeover with latching	changeover with latching	changeover with latching
-	-	-
-	-	-
-	-	-
-	-	-
-	-	-
-	-	-
-	-	-
-	-	-
-	-	-
-	-	-
■	■	■
■	■	■
■	■	■
-	-	-
continuous	continuous	continuous
continuous	continuous	continuous
continuous	continuous	continuous

(6) Maximum time to clear the fault current when combined with a Schneider Electric circuit breaker or switch rated ≤ 630 A.  
(7) Depending on version.

# Characteristics

## Protection relays with output contact requiring local manual reset after a fault

### Vigirex relays

#### General characteristics

Monitored distribution system: LV AC / System voltage

System earthing arrangement

A, AC type class as per IEC 60947-2 appendix M <sup>(1)</sup>

Operating-temperature range

Storage-temperature range

#### Electrical characteristics as per IEC 60755 and EN 60755, IEC 60947-2 and EN 60947-2, UL 1053 and CSA C22.2 N° 144 for RH10 to 99 with U<sub>e</sub> ≤ 220 V

Power supply: 12 to 24 V AC -12 to 48 V DC 50/60 Hz / DC

rated operational voltage U<sub>e</sub> 48 V AC - 24 to 130 V DC 50/60 Hz / DC

110 to 130 V AC 50/60 Hz

220 to 240 V AC 50/60/400 Hz

380 to 415 V AC 50/60 Hz

440 to 525 V AC 50/60 Hz

Operational voltage tolerances

U<sub>e</sub> : 12 to 24 V AC - 12 to 48 V DC

U<sub>e</sub> : 48 V AC - 24 to 130 V DC

U<sub>e</sub> : 48 to 415 V

U<sub>e</sub> : 110 to 415 V

U<sub>e</sub> > 415 V

Overvoltage category

Rated impulse withstand voltage up to U<sub>e</sub> = 525 V AC U<sub>imp</sub> (kV)

Maximum consumption AC

DC

Insensitive to micro-outages ≤ 60 ms

Maximum break time on toroid failure (as per standard IEC 60947-2)

Leakage-current measurements Measurement range

Measurement accuracy

Display measurement

Display refresh time

Fault current detection

Threshold I<sub>Δn</sub>

Fault-current detection range

Time delay Δt

Δt settings (s)

Maximum non-operating time at 2 I<sub>Δn</sub> (s)

Maximum operating time at 5 I<sub>Δn</sub> (s)

(residual-current relay alone)

Maximum total time at 5 I<sub>Δn</sub> <sup>(2)</sup> (s)

Setting

Output contact

Alarm

I alarm threshold

Alarm-current detection range

Time delay Δt alarm

Δt alarm settings

Maximum non-detection time at 2 I alarm

Maximum detection time at 5 I alarm

Setting

Output contact

Hysteresis

Test with or without actuation of the output contacts and output-contact reset following a fault

Local

Remote (hard-wired) (10 m maximum)

Remote (hard-wired for several relays) (10 m maximum)

Remote (via communication)

Self-monitoring

Relay/sensor link

Power supply

Electronics

(1) Type A relays up to 5 A.

(2) Maximum time to clear the fault current when combined with a Schneider Electric circuit breaker or switch rated ≤ 630 A.

(3) 110 VAC, 230 VAC and 400 VAC only.

(4) 80 % to 110 % U<sub>e</sub> if U<sub>e</sub> < 28 V.

(5) 85 % during energisation.

(6) < 10 % of I<sub>Δn</sub>: display = 0 and > 200 % of I<sub>Δn</sub>: display = SAT.

(7) Depending on version.

(8) Not available for DC version.

RH197M	RH197P	RHUs and RHU
50/60/400 Hz ≤ 1000 V	50/60/400 Hz ≤ 1000 V	50/60/400 Hz ≤ 1000 V
TT, TNS, IT	TT, TNS, IT	TT, TNS, IT
■	■	■
-25 °C / +55 °C	-25 °C / +55 °C	-25 °C / +55 °C
-40 °C / +85 °C	-40 °C / +85 °C	-40 °C / +85 °C
-	-	-
■	■	■
■ <sup>(3)</sup>	■	■
■ <sup>(3)</sup>	■	■
■ <sup>(3)</sup>	■	■
-	-	-
-	-	-
80 % to 110 % Ue <sup>(4)</sup>	70 % to 110 % Ue	-
-	-	70 % to 110 % Ue <sup>(5)</sup>
85 % to 110 % Ue	70 % to 110 % Ue	-
-	-	-
4	4	4
8	8	8
4 VA	4 VA	4 VA
4 W	4 W	-
■	■	■
■	■	■
-	-	from 15 mA to 60 A
±7 %	±7 %	±7 %
4 DEL 20, 30, 40 and 50 % of IΔn	4 DEL 20, 30, 40 and 50 % of IΔn	from ±10 % <sup>(6)</sup> to 200 % of IΔn
0.5 s	0.5 s	2 s
19 user-selectable thresholds 0.03 A - 0.05 A - 0.075 A - 0.1 A - 0.15 A - 0.2 A - 0.3 A - 0.5 A - 0.75 A - 1 A - 1.5 A - 2 A - 3 A - 5 A - 7.5 A - 10 A - 15 A - 20 A - 30 A	19 user-selectable thresholds 0.03 A - 0.05 A - 0.075 A - 0.1 A - 0.15 A - 0.2 A - 0.3 A - 0.5 A - 0.75 A - 1 A - 1.5 A - 2 A - 3 A - 5 A - 7.5 A - 10 A - 15 A - 20 A - 30 A	1 adjustable threshold from 0.03 A to 1 A in 0.001 A steps from 1 A to 30 A in 0.1 A steps
80 % IΔn to 100 % IΔn	80 % IΔn to 100 % IΔn	80 % IΔn to 100 % IΔn
instantaneous for IΔn = 0.03 A	instantaneous for IΔn = 0.03 A	instantaneous for IΔn = 0.03 A
7 user-selectable time delays	7 user-selectable time delays	1 adjustable time delay to 4.5 s
instantaneous to 4.5 s	instantaneous to 4.5 s	in 10 ms steps
0 0.06 0.15 0.31 0.5 1 4.5	0 0.06 0.15 0.31 0.5 1 4.5	0 0.06 ≤ Δt
- 0.06 0.15 0.31 0.5 1 4.5	- 0.06 0.15 0.31 0.5 1 4.5	- same as for RH99
0.020 0.13 0.32 0.39 0.58 1.08 4.58	0.020 0.13 0.32 0.39 0.58 1.08 4.58	0.015 same as for RH99
0.04 0.20 0.34 0.41 0.6 1.1 4.6	0.04 0.20 0.34 0.41 0.6 1.1 4.6	0.04 same as for RH99
selector	selector	keypad
changeover with latching in manual position; 10 automatic resets in auto position (see algorithm)	changeover with latching in manual position; 10 automatic resets in auto position (see algorithm)	changeover with latching
setting by Dip switch at 50 % of IΔn or 100 % of IΔn	fixed at 50 % of IΔn or 100 % of IΔn <sup>(7)</sup>	1 adj. threshold from 20 to 100 % IΔn 0.015 A to 1 A in 0.001 A steps 1 A to 30 A in 0.1 A steps 0.015 A < I alarm < 30 A
±7 % of IΔn	±7 % of IΔn	80 % I alarm to 100 % I alarm
instantaneous	instantaneous	1 adjustable time delay instantaneous to 4.5 s in 10 ms steps
-	-	0 s 0.06 s ≤ Δt
-	-	- same as for IΔn
-	-	0.015 s same as for IΔn
-	-	keypad
NO without latching	NO without latching	YES
0, -10 % IΔn	0, -10 % IΔn	alarm deactivated at 70 % of I alarm threshold
■	■	■
■ <sup>(8)</sup>	■	■
-	-	■ RHU only
-	-	continuous
continuous	continuous	continuous
continuous	continuous	continuous
watch-dog in microprocessor	watch-dog in microprocessor	continuous

Vigirex relays		RH10 - RH21 - RH68 - RH86 - RH99					
<b>Electrical characteristics as per IEC 60755 and EN 60755, IEC 60947-2 and EN 60947-2, UL 1053 and CSA C22.2 N° 144 for RH10 to 99 with Ue ≤ 220 V (cont.)</b>							
Characteristics of output contacts as per standard IEC 60947-5-1	Rated thermal current (A)	8					
	Minimum load	10 mA at 12 V					
Rated operational current (A)	Utilisation category	AC12	AC13	AC14	AC 15	DC12	DC13
	24 V	6	6	5	5	6	2
	48 V	6	6	5	5	2	-
	110-130 V	6	6	4	4	0.6	-
	220-240 V	6	6	4	4	-	-
	250 V	-	-	-	-	0.4	-
	380-415 V	5	-	-	-	-	-
	440 V	-	-	-	-	-	-
	660-690 V	-	-	-	-	-	-
Display and indications	Voltage presence (LED and/or relay) <sup>(1)</sup>	■					
	Threshold overrun fault (LED)	■					
	alarm (LED and relay)	-					
	Leakage current and settings (digital)	-					
Setting protection	sealable cover						
<b>Communication</b>							
Suitable for supervision (internal bus)	-						
<b>Mechanical characteristics</b>		<b>DIN</b>			<b>Front-panel mount</b>		
Dimensions	6 modules x 9 mm			72 x 72 mm			
Weight	0.3 kg			0.3 kg			
Insulation class (IEC 60664-1)	Front face	2			2		
	Communication output	-			-		
Degree of protection IP (IEC 60529)	Front face	IP40			IP40		
	Other faces	IP30			IP30		
	Connections	IP20			IP20		
Mechanical impact on front face IK (EN 50102)	IK07 (2 joules)			IK07 (2 joules)			
Sinusoidal vibrations (Lloyd's and Veritas)	2 to 13.2 Hz ±1 mm and 13.2 to 100 Hz - 0.7 g			2 to 13.2 Hz ±1 mm and 13.2 to 100 Hz - 0.7 g			
Fire (IEC 60695-2-1)	■			■			
<b>Environment</b>							
Damp heat, equipment not in service (IEC 60068-2-30)	28 cycles +25 °C / +55 °C / RH 95 %						
Damp heat, equipment in service (IEC 60068-2-56)	48 hours, Environment category C2						
Salt mist (IEC 60068-2-52)	KB test, severity 2						
Degree of pollution (IEC 60664-1)	3						
Electromagnetic compatibility <sup>(2)</sup>	Electrostatic discharges (IEC 61000-4-2)	Level 4					
	Radiated susceptibility (IEC 61000-4-3)	Level 3					
	Low-energy conducted susceptibility (IEC 61000-4-4)	Level 4					
	High-energy conducted susceptibility (IEC 61000-4-5)	Level 4					
	Radiofrequency interference (IEC 61000-4-6)	Level 3					
	Conducted and radiated emissions (CISPR11)	Class B					
<b>Sensors and accessories</b>							
Sensors	A, TOA type toroids	■					
	L type rectangular sensors for IΔn ≥ 300 mA	■					
Cables	Relay/sensor link via standard twisted pair not supplied	■					

(1) Depending on the type of wiring (optimum continuity of service or optimum safety).

(2) Compatibility for both relay and sensor.

(3) No voltage presence relay.

(4) By bargraph.

RH197						RHUs and RHU					
8 10 mA at 12 V						8 10 mA at 12 V					
AC12	AC13	AC14	AC 15	DC12	DC13	AC12	AC13	AC14	AC15	DC12	DC13
6	6	5	5	6	2	6	6	5	5	6	2
6	6	5	5	2	-	6	6	5	5	2	-
6	6	4	4	0.6	-	6	6	4	4	0.6	-
6	6	4	4	-	-	6	6	4	4	-	-
-	-	-	-	0.4	-	-	-	-	-	0.4	-
5	-	-	-	-	-	5	-	-	-	-	-
-	-	-	-	-	-	-	-	-	-	-	-
-	-	-	-	-	-	-	-	-	-	-	-
■ (3)						■					
■						■					
■						■					
■ (4)						■					
sealable cover						by password on the display					
-			■ (RHU only)								
<b>DIN</b>			<b>Front-panel mount</b>			<b>Front-panel mount</b>					
8 modules x 9 mm - H 89 mm			72 x 72 mm			72 x 72 mm					
0.3 kg			0.3 kg			0.3 kg					
2			2			2					
-			-			2					
IP40			IP40			IP40					
IP30			IP30			IP30					
IP20			IP20			IP20					
IK07 (2 joules)			IK07 (2 joules)			IK07 (2 joules)					
2 to 13.2 Hz ±1 mm and 13.2 to 100 Hz - 0.7 g			2 to 13.2 Hz ±1 mm and 13.2 to 100 Hz - 0.7 g			2 to 13.2 Hz ±1 mm and 13.2 to 100 Hz - 0.7 g					
■			■			■					
<b>DIN</b>			<b>Front-panel mount</b>			<b>Front-panel mount</b>					
28 cycles +25 °C / +55 °C / RH 95 %			28 cycles +25 °C / +55 °C / RH 95 %			28 cycles +25 °C / +55 °C / RH 95 %					
48 hours, Environment category C2			48 hours, Environment category C2			48 hours, Environment category C2					
KB test, severity 2			KB test, severity 2			KB test, severity 2					
3			3			3					
Level 4			Level 4			Level 4					
Level 3			Level 3			Level 3					
Level 4			Level 4			Level 4					
Level 4			Level 4			Level 4					
Level 3			Level 3			Level 3					
Class B			Class B			Class B					
■			■			■					
■			■			■					
■			■			■					

# Characteristics

## Monitoring relays with output contact that automatically resets after fault clearance

PB100434-30\_SE.eps



RH99M.

PB100432-30\_SE.eps



RH99P.

PB114607-R4.eps



RMH.

+

059405-51\_SE.eps



RM12T.

### Vigirex relays

#### General characteristics

Monitored distribution system: LV AC / System voltage

System earthing arrangement

A, AC type class as per IEC 60947-2 appendix M

Operating-temperature range

Storage-temperature range

#### Electrical characteristics

Power supply: 12 to 24 V AC - 12 to 48 V DC 50/60 Hz / DC

rated operational voltage  $U_e$  110 to 130 V AC 50/60 Hz

220 to 240 V AC 50/60/400 Hz

380 to 415 V AC 50/60 Hz

440 to 525 V AC 50/60 Hz

Operational voltage tolerances  $U_e$ : 12 to 24 V AC -12 to 48 V DC

$48 V \leq U_e \leq 415 V$

$U_e > 415 V$

Oversoltage category

Rated impulse withstand voltage up to  $U_e = 525 V AC$   $U_{imp}$  (kV)

Maximum consumption AC

DC

Insensitive to micro-outages  $\leq 60 ms$

Maximum break time on toroid failure (as per standard IEC 60947-2)

Leakage-current measurements Measurement range

Measurement accuracy

Measurement time for 1 channel

Measurement time for 12 channels

Display measurement

Alarm Display refresh time

$I_{\Delta n}$  threshold

Alarm-current detection range

Time delay  $\Delta t$  alarm

$\Delta t$  alarm settings (s)

Maximum non-detection time at  $2 I_{\Delta n}$  (2 I alarm for RMH) (s)

Maximum detection time at  $5 I_{\Delta n}$  (5 I alarm for RMH) (s)

Setting

Output contact

Pre-alarm Hysteresis

I pre-alarm threshold

Pre-alarm current detection range

Time delay  $\Delta t$  pre-alarm

Accuracy

Setting

Output contact

Hysteresis

Test with or without activation of output contacts Local

Remote (hard-wired) (10 m maximum)

Remote (hard-wired for several relays) (10 m maximum)

Remote (via communication)

Self-monitoring Relay/sensor link

Sensor/multiplexer RM12T and RM12T/RMH link

Power supply

Electronics

(1) 80 % to 120 %  $U_e$  if  $U_e < 20 V$ .

(2) -15 % during energisation.

(3) < 10 % of  $I_{\Delta n}$ : display = 0 and > 200 % of  $I_{\Delta n}$ : display = SAT.

RH99	RHUs and RHU	RMH and RM12T associated
50/60/400 Hz ≤ 1000 V	50/60/400 Hz ≤ 1000 V	50/60/400 Hz ≤ 1000 V
TT, TNS	TT, TNS, IT	TT, TNS
-	■	-
-35 °C / +70 °C	-25 °C / +55 °C	-25 °C / +55 °C
-55 °C / +85 °C	-40 °C / +85 °C	-40 °C / +85 °C
■	-	-
■	■	-
■	■	■
■	-	-
■	-	-
55 % to 120 % Ue <sup>(1)</sup>	-	-
55 % to 110 % Ue	70 % to 110 % Ue	70 % to 110 % Ue <sup>(2)</sup>
70 % to 110 % Ue	-	-
4	4	4
8	8	8
4 VA	4 VA	8 VA
4 W	-	-
■	■	■
■	■	■
from 15 mA to 60 A	from 15 mA to 60 A	from 15 mA to 60 A on 12 measurement channels
±7 %	±7 %	±10 % of I alarm
-	< 200 ms	< 200 ms
-	-	< 2.4 s (< n x 200 ms if n toroids)
-	from 10 % <sup>(3)</sup> to 200 % of IΔn	from 10 % <sup>(3)</sup> to 200 % of IΔn
-	2 s	2 s
9 user-selectable thresholds 0.03 A - 0.1 A - 0.3 A - 0.5 A - 1 A - 3 A - 5 A - 10 A - 30 A	1 adjustable threshold from 0.03 A to 1 A in 0.001 A steps from 1 A to 30 A in 0.1 A steps	1 adjustable threshold/channel from 0.03 A to 1 A in 0.001 A steps from 1 A to 30 A in 0.1 A steps
80 % IΔn to 100 % IΔn instantaneous for IΔn = 0.03 A 9 user-selectable time delays: instantaneous to 4.5 s	80 % IΔn à 100 % IΔn instantaneous for IΔn = 0.03 A 1 adjustable time delay to 4.5 s in 10 ms steps	80 % IΔn à 100 % IΔn instantaneous for IΔn = 0.03 A 1 adjustable delay/channel instantaneous to 5 s in 10 ms steps
0   0.06   0.15   0.25   0.31   0.5   0.8   1   4.5		0 s   other time delays
-   0.06   0.15   0.25   0.31   0.5   0.8   1   4.5		0.2 s   0.2 s + Δt alarm
0.015   0.13   0.23   0.32   0.39   0.58   0.88   1.08   4.58		2.4 s   2.4 s + (1.2 x Δt alarm)
selector	keypad	keypad
changeover	changeover	changeover
none	alarm contact deactivated at 70 % of I alarm threshold	alarm contact deactivated at 70 % of I alarm threshold
-	1 adj. threshold from 20 to 100 % IΔn 0.015 A to 1 A in 0.001 A steps 1 A to 30 A in 0.1 A steps	1 adj. threshold/channel from 20 to 100 % IΔn 0.015 A to 1 A in 0.001 A steps 1 A to 30 A in 0.1 A steps 0.015 A ≤ I pre-alarm ≤ I alarm ≤ 30 A
-	80 % I pre-alarm to 100 % I pre-alarm	80 % I pre-alarm to 100 % I pre-alarm
-	1 adjustable delay instantaneous to 4.5 s in 10 ms steps	1 adjustable delay/channel instantaneous to 4.5 s in 10 ms steps
-	0/-20 % for all settings not including polling time	0/-20 % for all settings not including polling time
-	keypad	keypad
-	YES	YES
-	pre-alarm contact deactivated at 70 % of I pre-alarm threshold	pre-alarm contact deactivated at 70 % of I pre-alarm threshold
■	■	■
■	■	-
■	-	-
-	■ (RHU only)	■
continuous	continuous	continuous
-	-	continuous
continuous	continuous	continuous
continuous	continuous	continuous

# Characteristics

## Monitoring relays with output contact that automatically resets after fault clearance (cont.)

PB100434-36\_SE.eps



RH99M.

PB100432-36\_SE.eps



RH99P.

PB114387-RR.eps



RMH.

+

059485-51\_SE.eps



RM12T.

### Vigirex relays

#### Electrical characteristics (cont.)

Characteristics of output contacts as per standard IEC 60947-5-1	Rated thermal current (A)
Rated operational current (A)	Minimum load
	Utilisation category
	24 V
	110-130 V
	220-240 V
	250 V
	380-415 V
	440 V
	660-690 V
Display and indications	Voltage presence (LED and/or relay)
	Threshold overrun alarm (LED and relay)
	pre-alarm (LED and relay)
	Leakage current and settings (digital)

Setting protection

#### Communication

Suitable for supervision (internal bus)

#### Mechanical characteristics

Dimensions

Weight

Insulation class (IEC 60664-1)	Front face
	Communication output
Degree of protection IP (IEC 60529)	Front face
	Other faces
	Connections

Mechanical impact on front face IK (EN 50102)

Sinusoidal vibrations (Lloyd's and Veritas)

Fire (IEC 60695-2-1)

#### Environment

Damp heat, equipment not in service (IEC 60068-2-30)

Damp heat, equipment in service (IEC 60068-2-56)

Salt mist (IEC 60068-2-52)

Degree of pollution (IEC 60664-1)

Electromagnetic compatibility <sup>(1)</sup>	Electrostatic discharges (IEC 61000-4-2)
	Radiated susceptibility (IEC 61000-4-3)
	Low-energy conducted susceptibility (IEC 61000-4-4)
	High-energy conducted susceptibility (IEC 61000-4-5)
	Radiofrequency interference (IEC 61000-4-6)
	Conducted and radiated emissions (CISPR11)

#### Sensors and accessories

Sensors	A, TOA type toroids
	L type rectangular sensor for $I_{\Delta n} \geq 300$ mA
Cables	Relay/sensor link via standard twisted pair not supplied

<sup>(1)</sup> Compatibility for both relay and sensor.

RH99							RHUs and RHU						RMH and RM12T associated					
													RMH			RM12T		
8							8						8					
10 mA at 12 V							10 mA at 12 V						10 mA at 12 V					
AC12	AC13	AC14	AC15	DC12	DC13		AC12	AC13	AC14	AC15	DC12	DC13	AC12	AC13	AC14	AC15	DC12	DC13
6	6	5	5	6	2		6	6	5	5	6	2	6	6	5	5	6	2
6	6	4	4	0.6	-		6	6	4	4	0.6	-	6	6	4	4	0.6	-
6	6	4	4	-	-		6	6	4	4	-	-	6	6	4	4	-	-
-	-	-	-	0.4	-		-	-	-	-	0.4	-	-	-	-	-	0.4	-
5	-	-	-	-	-		5	-	-	-	-	-	5	-	-	-	-	-
-	-	-	-	-	-		-	-	-	-	-	-	-	-	-	-	-	-
-	-	-	-	-	-		-	-	-	-	-	-	-	-	-	-	-	-
■							■							■	LED			
■ (fault indication)							■						-					
-							■						-					
-							■						-					
sealable cover							by password on the display						by password on the display					
-							■ (RHU only)						■					
<b>DIN</b>		<b>Front-panel mount</b>					<b>Front-panel mount</b>						<b>Front-panel mount</b>			<b>DIN</b>		
6 modules x 9 mm		72 x 72 mm					72 x 72 mm						72 x 72 mm			12 modules x 9 mm		
0.3 kg		0.3 kg					0.3 kg						0.3 kg			0.42 kg		
2		2					2						2			-		
-		-					-						-			-		
IP40		IP40					IP40						IP40			IP40		
IP30		IP30					IP30						IP30			IP30		
IP20		IP20					IP20						IP20			IP20		
IK07 (2 joules)		IK07 (2 joules)					IK07 (2 joules)						IK07 (2 joules)			IK07 (2 joules)		
2 to 13.2 Hz ±1 mm and 13.2 to 100 Hz - 0.7 g		2 to 13.2 Hz ±1 mm and 13.2 to 100 Hz - 0.7 g					2 to 13.2 Hz ±1 mm and 13.2 to 100 Hz - 0.7 g						2 to 13.2 Hz ±1 mm and 13.2 to 100 Hz - 0.7 g			2 to 13.2 Hz ±1 mm and 13.2 to 100 Hz - 0.7 g		
■		■					■						■			■		
28 cycles +25 °C / +55 °C / RH 95 %							28 cycles +25 °C / +55 °C / RH 95 %						28 cycles +25 °C / +55 °C / RH 95 %					
48 hours, Environment category C2							48 hours, Environment category C2						48 hours, Environment category C2					
KB test, severity 2							KB test, severity 2						KB test, severity 2					
3							3						3					
Level 4							Level 4						Level 4					
Level 3							Level 3						Level 3					
Level 4							Level 4						Level 4					
Level 4							Level 4						Level 4					
Level 3							Level 3						Level 3					
Class B							Class B						Class B					
■							■						■					
■							■						■					
■							■						■					

089470-27\_SE.eps



A type closed toroid: IA80.

PB114688-R4.eps



TOA type split toroid: TOA120.

089470-48\_SE.eps



Type L rectangular sensor.

### Sensors

#### Associated relays

Monitoring relays  
Protection relays

#### Use

New installations and extensions  
Renovation and extensions

#### General characteristics

Monitored distribution system  
Insulation level  $U_i$   
Closed sensor  
Split sensor  
Operating-temperature range  
Storage-temperature range  
Degree of protection

#### Electrical characteristics

Transformation ratio  
Overvoltage category  
Rated impulse withstand voltage  $U_{imp}$  (kV)

#### Sensor characteristics

Rated operational current  $I_e$  (A)  
Conductor max. size per phase (mm<sup>2</sup> copper)  
Rated short-time withstand current **I<sub>cs</sub> kA/0.5 s**  
Residual short-circuit withstand current **I<sub>Δw</sub> kA/0.5 s**  
(IEC 60947-2)

#### Mechanical characteristics

##### Type of sensor

TA30 toroid  
PA50 toroid  
IA80 toroid  
MA120 toroid  
SA200 toroid  
GA300 toroid  
TOA80 toroid  
TOA120 toroid  
L1 rectangular sensor  
L2 rectangular sensor

#### Wiring

##### Wire size (mm<sup>2</sup>) for resistance $R = 3 \Omega$

0.22  
0.75  
1  
1.5

#### Mounting

Clip-on mounting on rear of Vigirex relay  
Symmetrical DIN rail (horizontal or vertical mounting)  
Plain, slotted or profiled plate  
On cable  
On busbars  
Opening / closing (number of operation)

#### Environment

Damp heat, equipment not in service (IEC 60068-2-30)  
Damp heat, equipment in service (IEC 60068-2-56)  
Salt mist (IEC 60068-2-52)  
Degree of pollution (IEC 60664-1)

(1) With RH10, RH21, RH99, RH197, RHUs and RHU,  $I_{\Delta n}$  must be  $\geq 300$  mA  
(2) From 0.5 to 2.5 mm<sup>2</sup>.

A type closed toroid							TOA type split toroid		L type rectangular sensor <sup>(1)</sup>	
RH99, RMH RH10, RH21, RH68, RH86, RH99, RH197, RHUs and RHU							RH99, RMH RH10, RH21, RH68, RH86, RH99, RH197, RHUs and RHU		RH99, RMH RH10, RH21, RH68, RH86, RH99, RH197, RHUs and RHU	
■ -							- ■		■ -	
BT 50/60/400 Hz 1000 V ■ -							BT 50/60/400 Hz 1000 V - ■		BT 50/60/400 Hz 1000 V ■ -	
-35 °C / +70 °C -55 °C / +85 °C IP30 (connections IP20)							-35 °C / +70 °C -55 °C / +85 °C IP40 (connections IP20)		-35 °C / +80 °C -55 °C / +100 °C IP30 (connections IP20)	
1/1000 4 12							1/1000 4 12		1/1000 4 12	
<b>TA30</b>	<b>PA50</b>	<b>IA80</b>	<b>MA120</b>	<b>SA200</b>	<b>GA300</b>	<b>TOA80</b>	<b>TOA120</b>	<b>L1 = 280 x 115</b>	<b>L2 = 470 x 160</b>	
65	85	160	250	400	630	160	250	1600	3200	
25	50	95	240	2 x 185	2 x 240	95	240	2 x 100 x 5	2 x 125 x 10	
25	50	50	85	85	85	50	85	100	100	
25	50	50	85	85	85	50	85	85	85	
<b>Dimensions ∅ (mm)</b>		<b>Weight (kg)</b>		<b>Dimensions ∅ (mm)</b>		<b>Weight (kg)</b>		<b>Inside dimensions (mm)</b>		<b>Weight (kg)</b>
30		0.120		-		-		-		-
50		0.200		-		-		-		-
80		0.420		-		-		-		-
120		0.590		-		-		-		-
200		1.320		-		-		-		-
300		2.280		-		-		-		-
-		-		80		0.9		-		-
-		-		120		1.5		-		-
-		-		-		-		280 x 115		11
-		-		-		-		470 x 160		20
<b>Max. link length (m)</b>							<b>Max. link length (m)</b>		<b>Max. link length (m)</b>	
18							18		-	
60							60		10 <sup>(2)</sup>	
80							80		10 <sup>(2)</sup>	
100							100		10 <sup>(2)</sup>	
TA30, PA50							-		-	
TA30, PA50, IA80, MA120							■		-	
TA30, PA50, IA80, MA120, SA200							■		-	
IA80, MA120, SA200, GA300							■		■	
-							-		■	
-							10 maximum		-	
28 cycles +25 °C / +55 °C / RH 95 % 48 hours, environment category C2 KB test, severity 2 3							28 cycles +25 °C / +55 °C / RH 95 % 48 hours, environment category C2 KB test, severity 2 3		28 cycles +25 °C / +55 °C / RH 95 % 48 hours, Environment category C2 KB test, severity 2 4	



---

<i>Functions and characteristics</i>	A-1
<b>Relays and associated toroids</b>	<b>B-2</b>
<b>Possible installation positions</b>	
RH10-21-68-86-99M/P, RH197M/P, RHUs, RHU and RMH	B-4
A and TOA type toroids and rectangular sensors	B-5
<b>Connection</b>	
Relays and sensors	B-6
Toroids and rectangular sensors	B-8
<b>Selection and installation instructions for toroids and rectangular sensors</b>	<b>B-9</b>
<i>Dimensions and connection</i>	C-1
<i>Wiring diagrams</i>	D-1
<i>Additional characteristics</i>	E-1
<i>Catalogue numbers</i>	F-1

## Residual-current protection relay

### Acti 9 format (DIN rail mount)

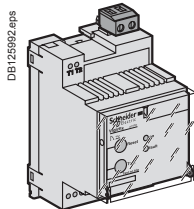

RH10M.

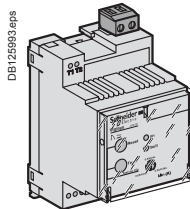

RH21M.

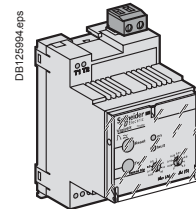

RH68M, RH86M, RH99M.

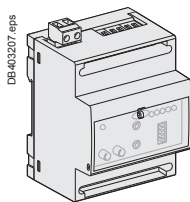

RH197M.

### Acti 9 format (with mounting accessories <sup>(1)</sup>)

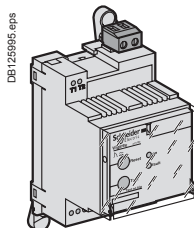

RH10M.

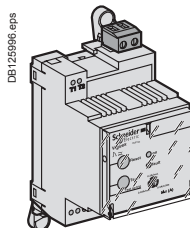

RH21M.

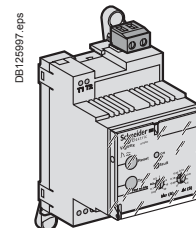

RH99M.

<sup>(1)</sup> Supplied as option, to be clipped into relay for installation on a mounting plate.

### Front-panel mount format

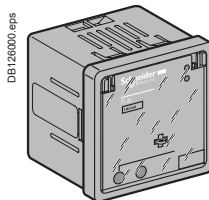

RH10P.

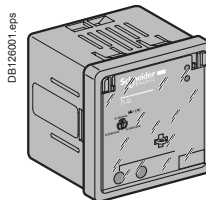

RH21P.

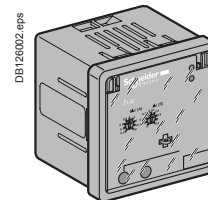

RH86P, RH99P

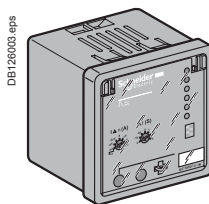

RH197P

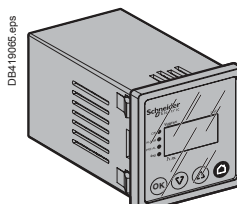

RHUs and RHU.

## Monitoring relays

### Acti 9 format

### Mounting accessories <sup>(1)</sup>

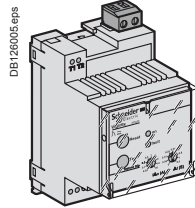

RH68M, RH86M, RH99M.  
(1) Supply as an option.

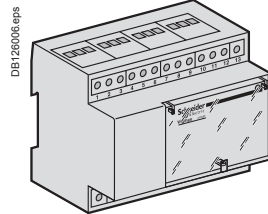

RM12T.

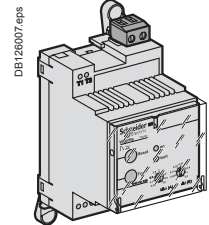

RH99M.

### Front-panel mount format

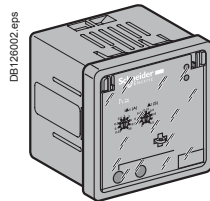

RH86P, RH99P.

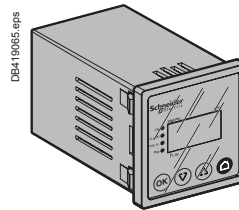

RMH.

The Vigirex RMH always requires a RM12T multiplexer.

## Toroids

### Closed from 30 to 300 mm

### Split (for retrofitting)

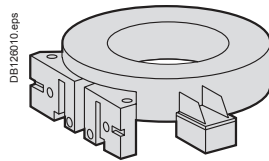

A toroid.

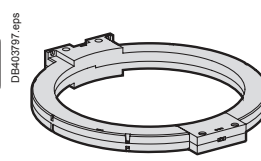

GA300 toroid.

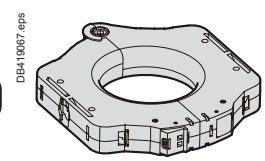

TOA toroid.

## Rectangular sensors

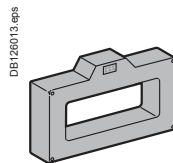

L1 = 280 x 115 mm.

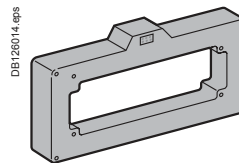

L2 = 470 x 160 mm.

## Selection and compatibility of toroids and rectangular sensors

Type of sensor			Type of Vigirex relay
Closed toroid	Split toroid	Rectangular sensor <sup>(1)</sup>	RH10-21-68-86-99, RH197, RHUs, RHU and RMH
TA30	-	-	■
PA50	TOA80	-	■
IA80	-	-	■
MA120	TOA120	-	■
SA200	-	-	■
GA300	-	-	■
-	-	L1	■
-	-	L2	■

(1) See restrictions in table below.

E toroids have not been included in the new range but are compatible with Vigirex relays subject to the following restrictions.

### Sensor restrictions table

Sensors	Relays
A type closed toroid	RH10, RH21, RH68, RH86, RH99, RH197, RHUs, RHU and RMH
TOA type split toroid	no restrictions
L type rectangular sensors	$I_{on} \geq 0.3 A$

# Possible installation positions

RH10-21-68-86-99M/P, RH197M/P,  
RHUs, RHU and RMH

## Possible installation positions

### Acti 9 format

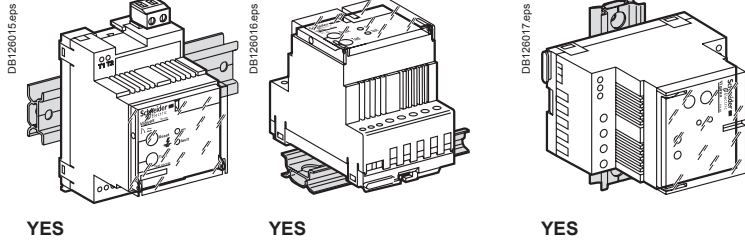

### Front-panel mount format

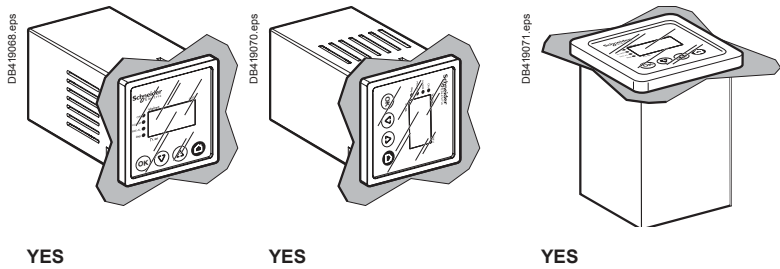

## Relay mounting possibilities

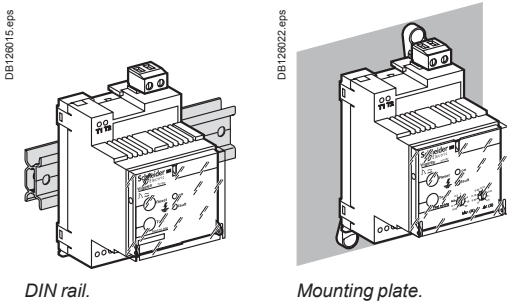

Mounting of Acti 9 format relays RH10M-21M-68M-86M-99M-RH197M  
The relay can be mounted in three ways:

- on a DIN rail (only this mounting for RH197M)
- on a mounting plate using 3 M4 screws (not supplied) and 3 removable mounting accessories (supplied).

### Mounting of front-panel mount relays RH10P-21P-86P-99P, RHUs, RHU and RMH

No special tools are required to mount the relay. Simply insert the device through the cutout. The size of the cutout complies with standard DIN 43700.

Front panel thickness: 1 mm minimum / 2.5 mm maximum.

The relay clips onto the panel.

### Mounting of relay RH197P

No tools are required to mount and secure the relay in position. Simply insert the device through the cutout and tighten the clamp by turning the knurled nut.

The size of the cutout complies with standard DIN 43700.

Front panel thickness: 1 mm minimum / 4 mm maximum.

### Mounting of RM12T multiplexer

The multiplexer must always be mounted on a DIN rail.

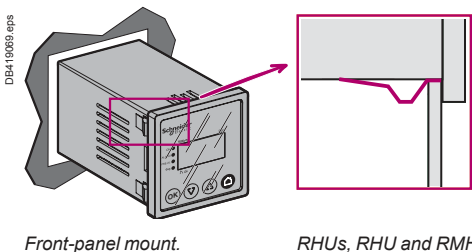

Front-panel mount.

RHUs, RHU and RMH details.

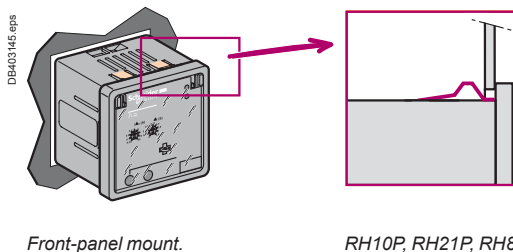

Front-panel mount.

RH10P, RH21P, RH86P and RH99P detail.

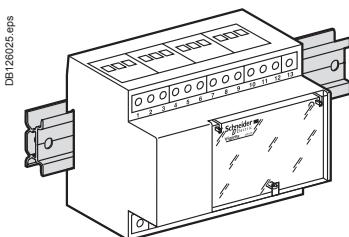

RM12T: DIN rail only.

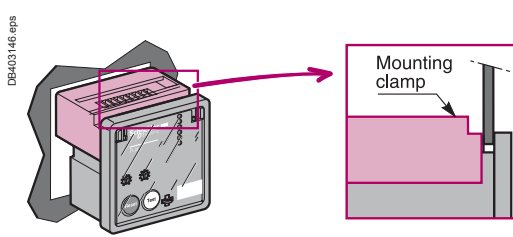

Front-panel mount.

RH197P detail.

# A and TOA type toroids and rectangular sensors

## Toroid mounting possibilities

### On DIN rail (TA30, PA50, IA80 and MA120) using supplied accessories

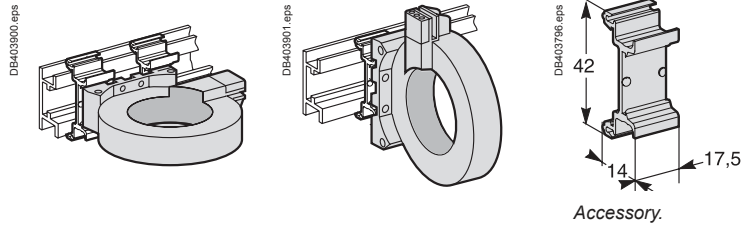

### On a plate (TA30, PA50, IA80, MA120, SA200, GA300, TOA80 and TOA120) or bracket

Screws not supplied

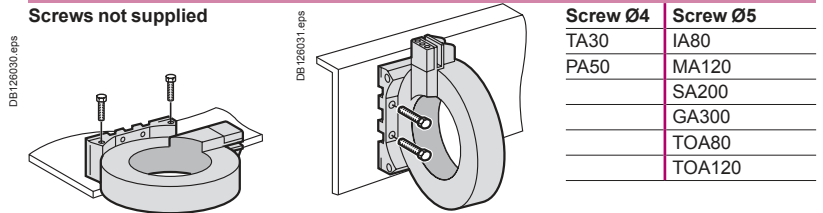

### Clipped on the back of the relay (TA30 and PA50)

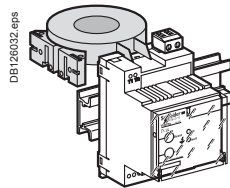

### Tied to cables (IA80, MA120, SA200 and GA300), cable-ties not supplied Cable-ties with 9 mm maximum width and 1.5 mm maximum thickness

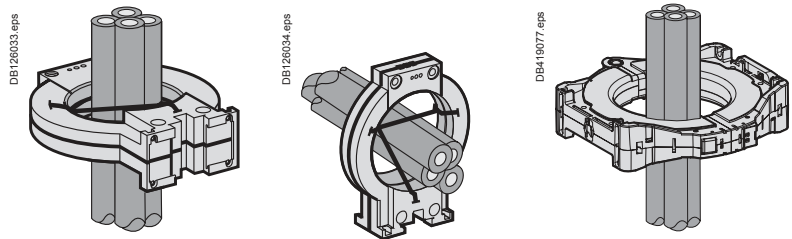

### Tied to cables (rectangular sensors)

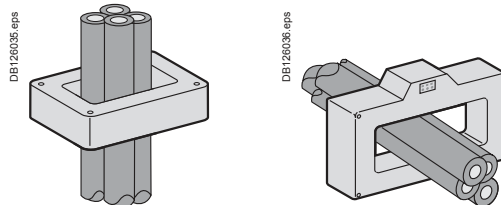

### On bars with chocks (rectangular sensors)

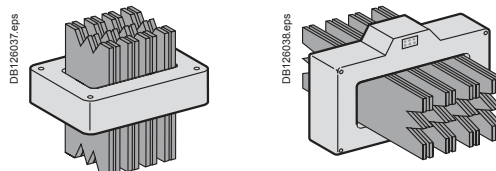

Product, terminal or screw	Cable type	Terminal capacity (mm <sup>2</sup> )						Conduct. size	Stripping		Tightening torque	
		Rigid min.	max.	Flexible min.	max.	Flexible with ferrule min.	max.		AWG	Rigid/flexible (mm)	(inch)	(N.m)
<b>RH10M, RH21M, RH68M, RH86M and RH99M</b>												
11, 14		0.2	4	0.2	2.5	0.25	2.5	24-12	8	.31	0.6	0.0678
31, 32, 34		0.2	4	0.2	2.5	0.25	2.5	24-12	8	.31	0.6	0.0678
A1, A2		0.2	2.5	0.2	2.5	0.25	2.5	24-12	7	.27	0.6	0.0678
T1, T2	twisted pair	0.14	1.5	0.14	1	0.25	0.5	26-16	5	.19	0.25	0.02825
25, 26, 27	3 twisted wires L<10 m	0.14	1.5	0.14	1	0.25	0.5	26-16	5	.19	0.25	0.02825
<b>RH197M</b>												
A1, A2		0.2	2.5	0.2	2.5	0.25	2.5	24-12	7	.27	0.6	0.0678
31, 32, 34		0.2	2.5	0.2	2.5	0.25	2.5	24-12	7	.27	0.6	0.0678
25-26, 27-28		0.2	2.5	0.2	2.5	0.25	2.5	24-12	7	.27	0.6	0.0678
T1, T2		0.2	2.5	0.2	2.5	0.25	2.5	24-12	7	.27	0.6	0.0678
41, 42, 44		0.2	2.5	0.2	2.5	0.25	2.5	24-12	7	.27	0.6	0.0678
<b>RH10P, RH21P, RH86P, RH99P</b>												
11, 14 or 41, 44		0.2	2.5	0.2	2.5	0.25	2.5	24-12	7	.27	0.6	0.0678
31, 32, 34		0.2	2.5	0.2	2.5	0.25	2.5	24-12	7	.27	0.6	0.0678
A1, A2		0.2	2.5	0.2	2.5	0.25	2.5	24-12	7	.27	0.6	0.0678
T1, T2	twisted pair	0.2	2.5	0.2	2.5	0.25	2.5	24-12	7	.27	0.6	0.0678
25, 26, 27	3 twisted wires L<10 m	0.2	2.5	0.2	2.5	0.25	2.5	24-12	7	.27	0.6	0.0678
<b>RH197P</b>												
11, 14		0.2	2.5	0.2	2.5	0.25	2.5	24-12	7	.27	0.6	0.0678
31, 32, 34		0.2	2.5	0.2	2.5	0.25	2.5	24-12	7	.27	0.6	0.0678
A1, A2		0.2	2.5	0.2	2.5	0.25	2.5	24-12	7	.27	0.6	0.0678
T1, T2	twisted pair	0.2	2.5	0.2	2.5	0.25	2.5	24-12	7	.27	0.6	0.0678
25, 26, 27	3 twisted wires L>10 m	0.2	2.5	0.2	2.5	0.25	2.5	24-12	7	.27	0.6	0.0678
<b>RHUs and RHU</b>												
A1, A2		0.2	2.5	0.2	2.5	0.25	2.5	22-12	6	.23	0.5	0.0565
11, 14		0.2	2.5	0.2	2.5	0.25	2.5	22-12	6	.23	0.5	0.0565
31, 32, 34		0.2	2.5	0.2	2.5	0.25	2.5	22-12	6	.23	0.5	0.0565
41, 44		0.2	2.5	0.2	2.5	0.25	2.5	22-12	6	.23	0.5	0.0565
T1, T2	twisted pair	0.2	2.5	0.2	2.5	0.25	2.5	22-12	6	.23	0.5	0.0565
25, 26, 27	3 twisted wires L<10 m	0.2	2.5	0.2	2.5	0.25	2.5	22-12	6	.23	0.5	0.0565
Bus <sup>(1)</sup>	24 V, 0 V	0.2	2.5	0.2	2.5	0.25	2.5	22-12	6	.23	0.5	0.0565
	-, +	0.2	2.5	0.2	2.5	0.25	2.5	22-12	6	.23	0.5	0.0565
<b>RMH</b>												
A1, A2		0.2	2.5	0.2	2.5	0.25	2.5	22-12	6	.23	0.5	0.0565
11, 14		0.2	2.5	0.2	2.5	0.25	2.5	22-12	6	.23	0.5	0.0565
31, 32, 34		0.2	2.5	0.2	2.5	0.25	2.5	22-12	6	.23	0.5	0.0565
41, 44		0.2	2.5	0.2	2.5	0.25	2.5	22-12	6	.23	0.5	0.0565
21, 22	twisted pair L<10 m	0.2	2.5	0.2	2.5	0.25	2.5	22-12	6	.23	0.5	0.0565
23, 24	twisted pair L<10 m	0.2	2.5	0.2	2.5	0.25	2.5	22-12	6	.23	0.5	0.0565
Bus	24 V, 0 V	0.2	2.5	0.2	2.5	0.25	2.5	22-12	6	.23	0.5	0.0565
	-, +	0.2	2.5	0.2	2.5	0.25	2.5	22-12	6	.23	0.5	0.0565
<b>RM12T</b>												
12 toroid connections 1 to 12 and 15 to 20	1 twisted pair/toroid L < 10 m	0.2	2.5	0.2	2.5	0.25	2.5	22-12	6	.23	0.5	0.0565
21, 22	twisted pair L<10 m	0.2	2.5	0.2	2.5	0.25	2.5	22-12	6	.23	0.5	0.0565
23, 24	twisted pair L<10 m	0.2	2.5	0.2	2.5	0.25	2.5	22-12	6	.23	0.5	0.0565
25, 26		0.2	2.5	0.2	2.5	0.25	2.5	22-12	6	.23	0.5	0.0565
<b>Toroid and sensors</b>												
TA30 and PA50 Ø 30 to 50 mm connectors supplied	twisted Cu/Al	0.2	2.5	0.2	2.5	0.2	1.5	24-14	6	.23	0.5	0.0565
IA80 to GA300 Ø 80 to 300 mm	twisted Cu/Al	0.2	2.5	0.2	2.5	0.2	1.5	24-1	6	.23	0.5	0.0565
TOA80 - TOA120 Ø 5 mm round lugs note supplied:		0.2	2.5	0.2	2.5	0.2	1.5	24-14	6	.23	0.6	5.2
S1, S2	twisted Cu/Al	-	-	-	-	-	-	-	-	-	3	0.339
Mounting on a mounting plate and DIN Rail clip		-	-	-	-	-	-	-	-	-	3.5	31
L1, L2: M1, M2	twisted pair L<10 m	0.5	2.5	0.5	2.5	0.5	2.5	20-14	8 to 9	.33	-	-

(1) RHU only.

## Connection of relays

### Acti 9 format

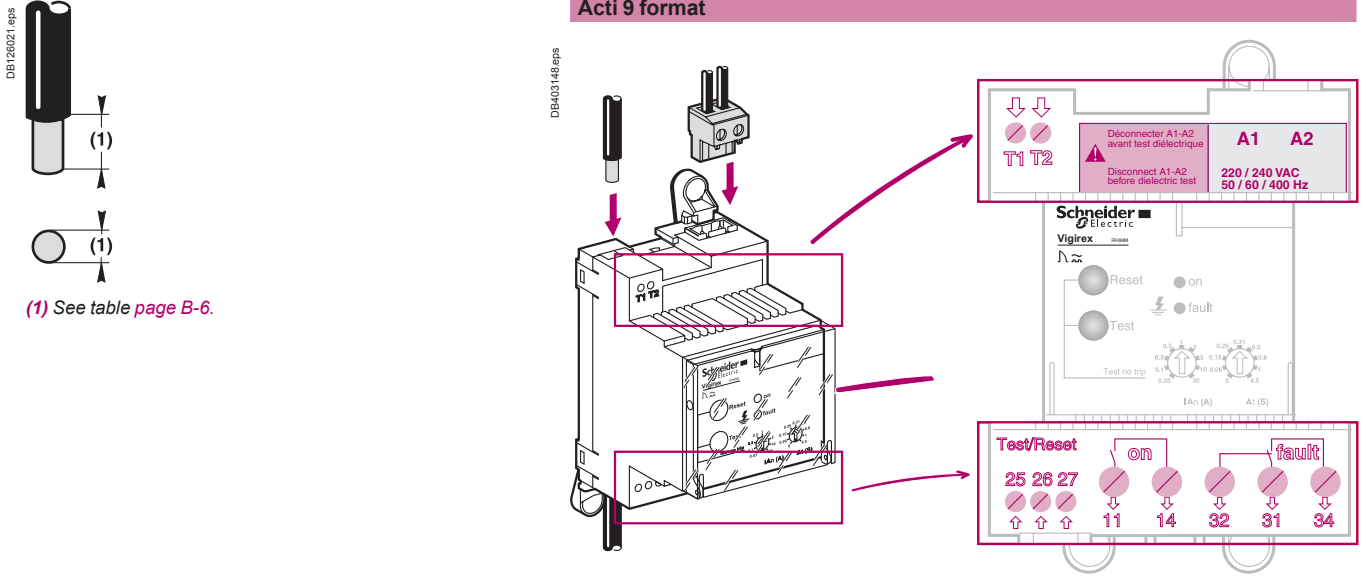

### Front-panel mount format

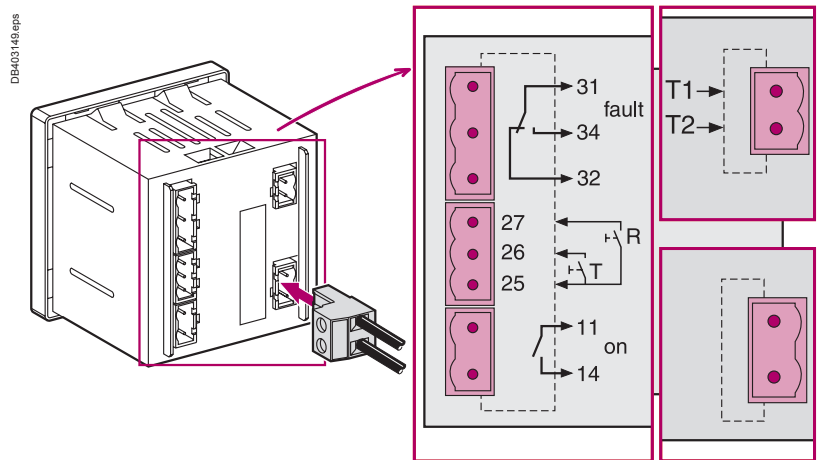

## Connection of toroids

### TA30 and PA50 closed toroids (connectors supplied)

### IA80, MA120, SA200 and GA300 closed toroids

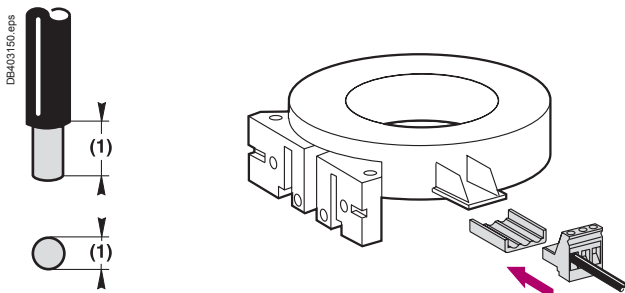

(1) See table page B-6.

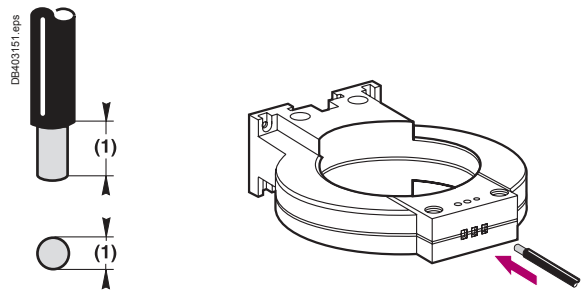

(1) See table page B-6.

### Connection of toroids (cont.)

TOA80 and TOA120 split toroids (Ø 5 mm round lugs not supplied)

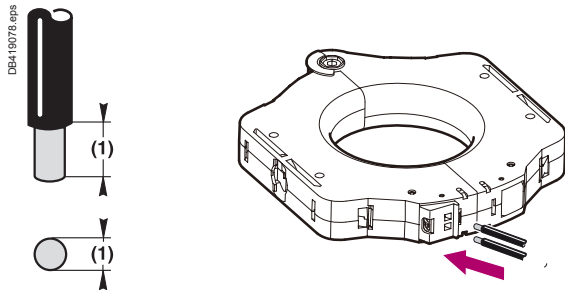

(1) See table page B-6.

### Connection of rectangular sensors and conductor layout

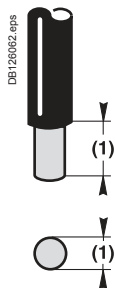

**L1: frame 280 x 115 mm**  
Busbars with 70 mm spacing

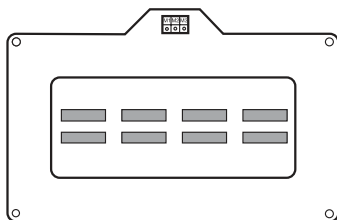

2 bars 50 x 10 mm (1600 A)  
The neutral can be located on the right or the left.

(1) See table page B-6.

**L2: frame 470 x 160 mm**  
Busbars with 115 mm spacing

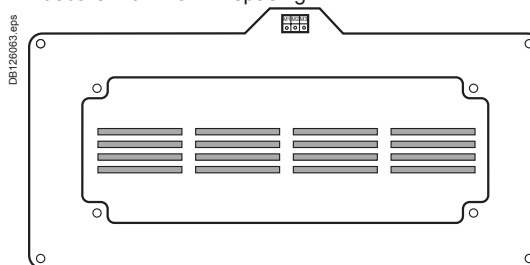

4 bars 100 x 5 mm (3200 A)  
The neutral can be located on the right or the left.

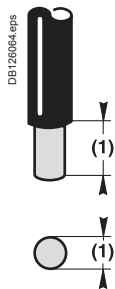

2 bars 100 x 5 mm (1600 A)  
The neutral can be located on the right or the left.

(1) See table page B-6.

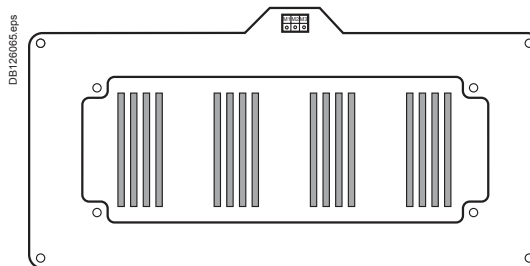

4 bars 125 x 5 mm (3200 A).  
The neutral can be located on the right or the left.

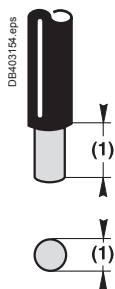

4 cables 240 mm<sup>2</sup> (1600 A)

(1) See table page B-6.

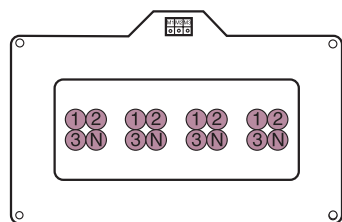

**Note:** connect M1 and M2 with Vigirex.

# Selection and installation instructions for toroids and rectangular sensors

## Cable layout

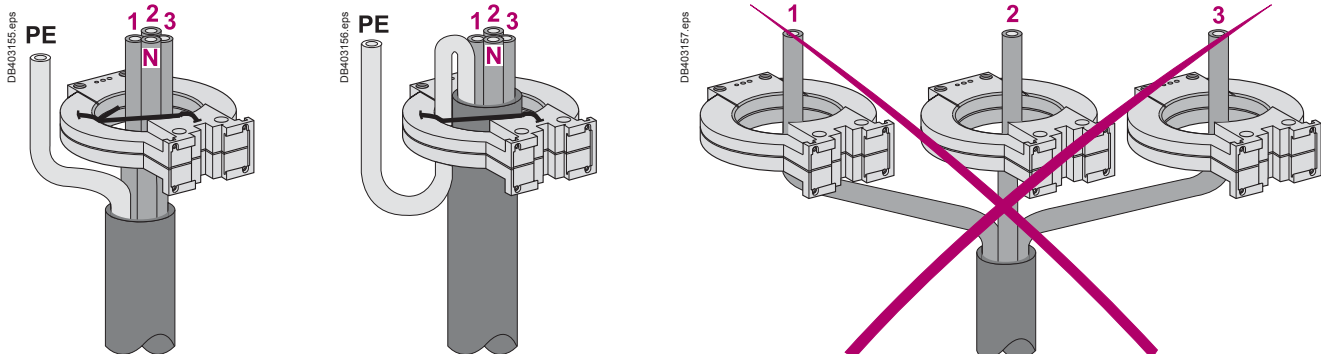

Centre the cables within the toroid

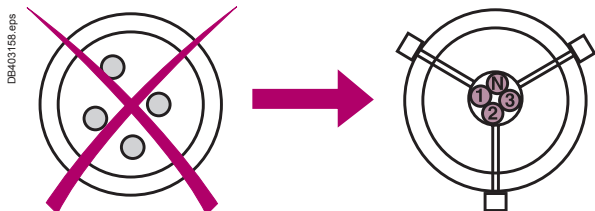

toroid  $\varnothing \geq 2 \times$  total cable  $\varnothing$

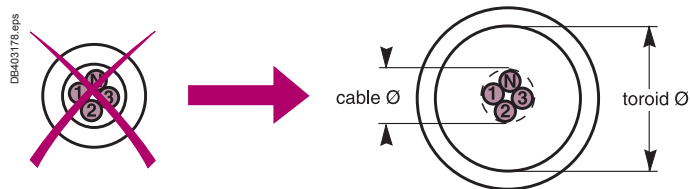

Do not bend cables near the toroids

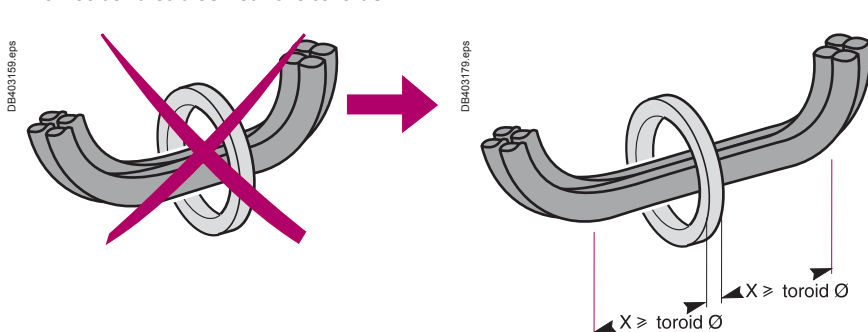

Single-phase or three-phase loads with several cables per phase

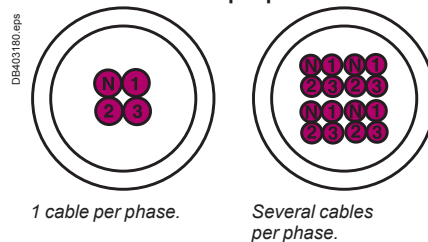

Do not bend cables near the sensors

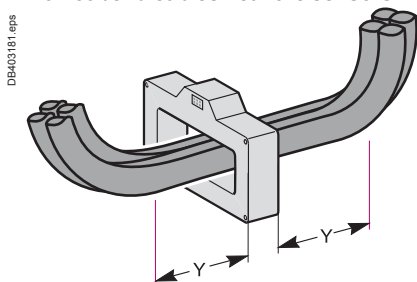

Do not bend bars near the sensors

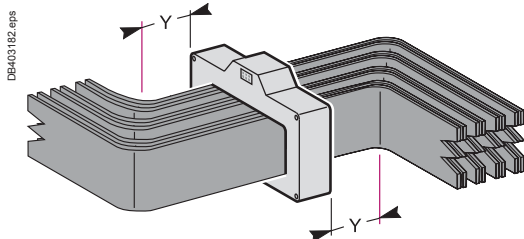

Note:  $Y \geq 25$  cm for 280 x 115 mm sensor.  
 $Y \geq 30$  cm for 470 x 160 mm sensor.

## Selection of toroids according to circuit power

3P + N copper cables

Rated operational current (Ie)	Max. cross-section/phase	Toroids
65 A	16 mm <sup>2</sup>	TA30
85 A	25 mm <sup>2</sup>	PA50 or TOA80
160 A	70 mm <sup>2</sup>	IA80
250 A	120 mm <sup>2</sup>	MA120 or TOA120
400 A	2 x 185 mm <sup>2</sup>	SA200
630 A	2 x 240 mm <sup>2</sup>	GA300
1600 A	4 x 240 mm <sup>2</sup>	L1

## Selection of rectangular sensors according to circuit power

3P + N copper bars

Rated operational current (Ie)	Max. cross-section/phase	Sensors
1600 A	2 bars 50 x 10 mm <sup>2</sup> 2 bars 100 x 5 mm <sup>2</sup>	L1
3200 A	4 bars 100 x 5 mm <sup>2</sup> 4 bars 125 x 5 mm <sup>2</sup>	L2

# Selection and installation instructions for toroids and rectangular sensors

## Immunitisation with respect to false zero-sequence currents (tested at 6 In as per IEC 60947-2 annex M)

The addition of a shielding ring prevents nuisance tripping with TA30, PA50, IA80 and MA120 toroids for the settings indicated in table below

For circuits with high transient currents (6 In)

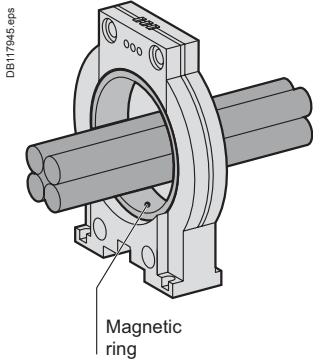

Sensor	In	Maximum cross-section per phase	IΔn
<b>With shielding ring</b>			
TA30	65 A	16 mm <sup>2</sup>	30 mA
PA50	85 A	25 mm <sup>2</sup>	30 mA
IA80	160 A	70 mm <sup>2</sup>	100 mA
MA120	250 A	120 mm <sup>2</sup>	100 mA
<b>Without shielding ring</b>			
SA200	400 A	2 x 185 mm <sup>2</sup>	300 mA
GA300	630 A	2 x 240 mm <sup>2</sup>	300 mA
TOA80	85 A	25 mm <sup>2</sup>	100 mA
TOA120	250 A	120 mm <sup>2</sup>	1 A
L1	1600 A	4 x 240 mm <sup>2</sup> or 2 copper bars 100 x 5 mm <sup>2</sup>	500 mA
L2	3200 A	2 copper bars 125 x 10 mm <sup>2</sup>	500 mA

## Connection between Vigrex relays and sensors

Vigrex relays must be connected to the sensors as indicated:

Cross-section (Cu)	Maximum length
<b>Toroids</b>	
0.22 mm <sup>2</sup> <sup>(1)</sup>	18 m
0.75 mm <sup>2</sup> <sup>(1)</sup>	60 m
1 mm <sup>2</sup> <sup>(1)</sup>	80 m
1.5 mm <sup>2</sup> <sup>(1)</sup>	100 m
<b>Rectangular sensors</b>	
0.5 mm <sup>2</sup> min. / 2.5 mm <sup>2</sup> max.	10 m

<sup>(1)</sup> Wire size for resistance R maximum = 3 Ω.

### Cable type

Standard twisted pair (not to be run alongside power cables).

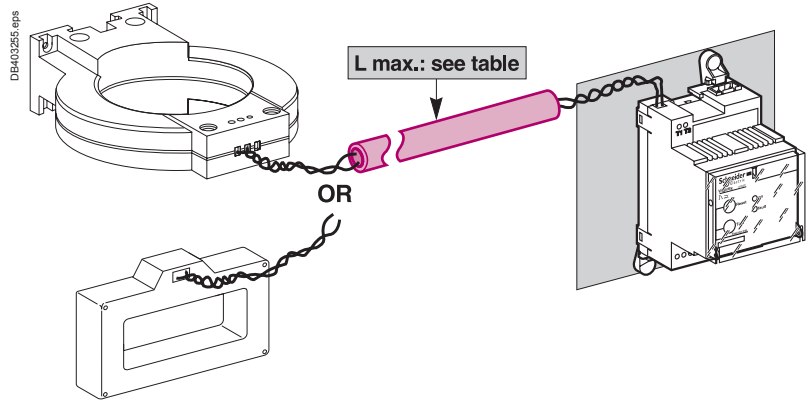

## In highly disturbed environments:

### Wiring

Shielded twisted pair (not to be run alongside power cables).

The shielding must be earthed at both ends by connection to the equipotential bonding circuit.

The cable between the toroid and the relay should be as short as possible.

If this is not sufficient, use a transformer with high frequency (HF) shielding.

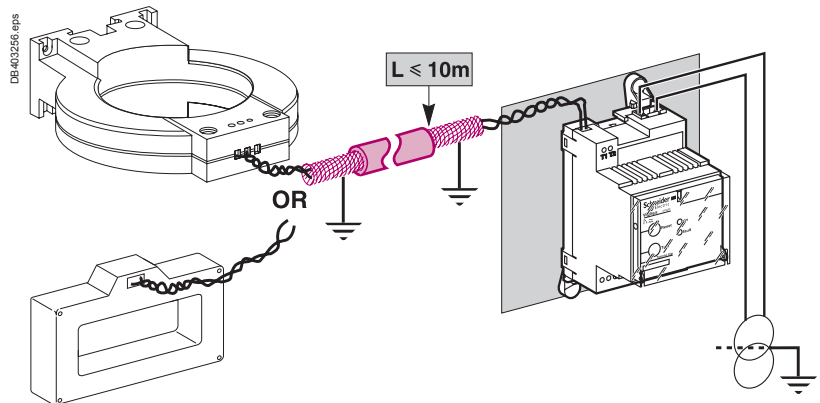

Auxiliary power supply via external transformer.

---

<i>Functions and characteristics</i>	A-1
<i>Installation recommendations</i>	B-1
<b>Dimensions</b>	
RH10M, RH21M, RH68M, RH86M, RH99M and RH197M relays	C-2
RH10P, RH21P, RH86P, RH99P, RH197P, RHUs, RHU, RMH and RM12T relays	C-3
A-type closed toroids	C-4
TOA split toroids and rectangular sensors	C-5
<i>Wiring diagrams</i>	D-1
<i>Additional characteristics</i>	E-1
<i>Catalogue numbers</i>	F-1

# Dimensions

## RH10M, RH21M, RH68M, RH86M, RH99M and RH197M relays

### Mounting on a DIN rail

RH10M, RH21M, RH68M, RH86M and RH99M

RH197M

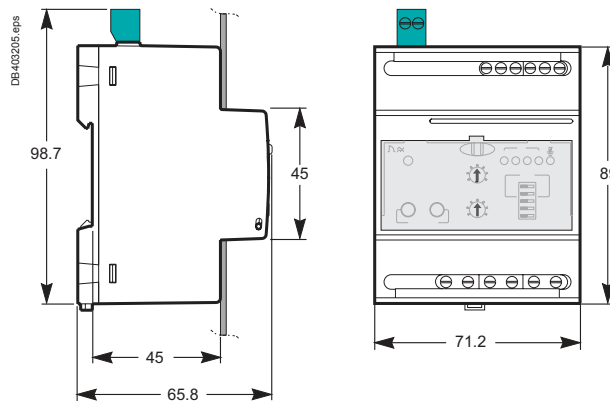
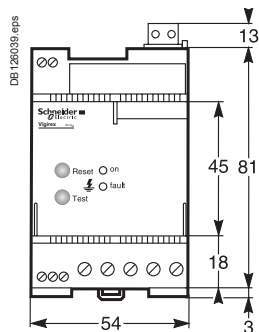
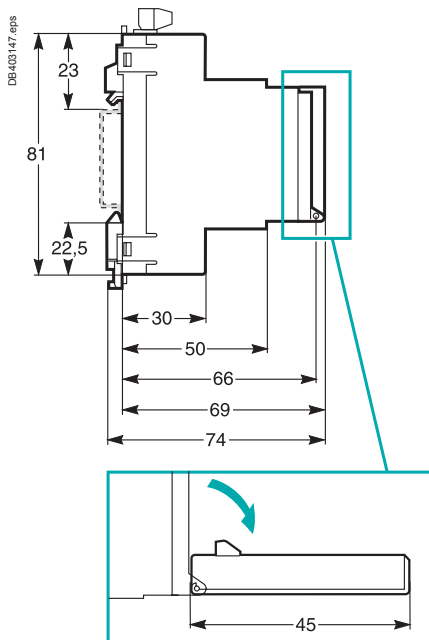

### Mounting on a mounting plate

RH10M, RH21M, RH68M, RH86M and RH99M

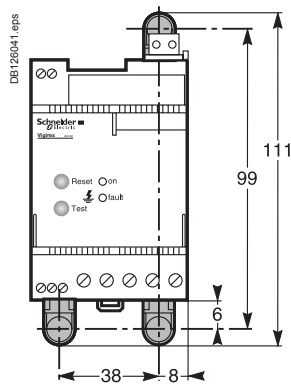
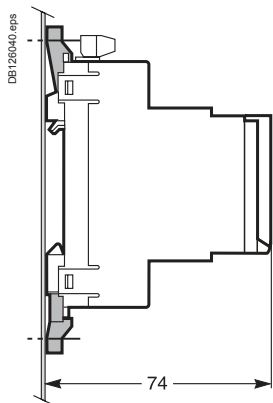

### Plate drilling layout

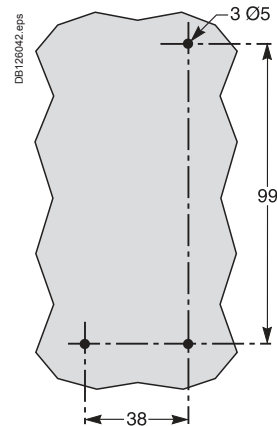

### Door cutout

Mounting on a DIN rail

Mounting on a mounting plate

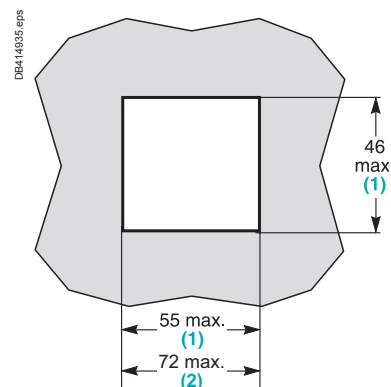
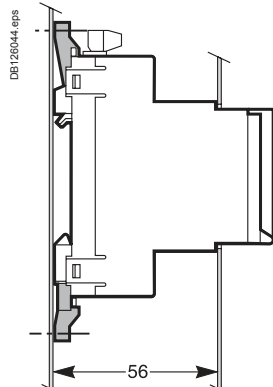
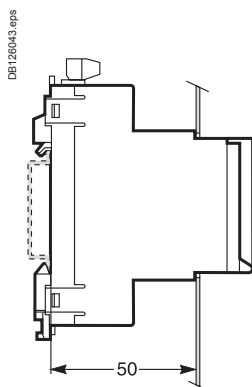

(1) For IP4 requirements.  
(2) For RH197M.

# RH10P, RH21P, RH86P, RH99P, RH197P, RHUs, RHU, RMH and RM12T relays

## Front-panel mount relays (cutout complying with standard DIN 43700)

### RH10P, RH21P, RH86P and RH99P

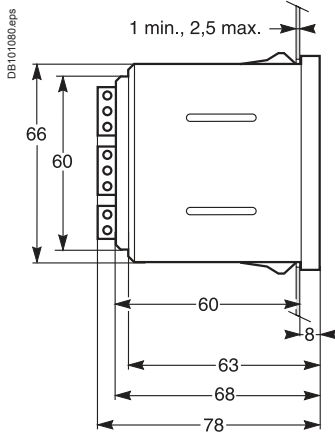

### RH197P

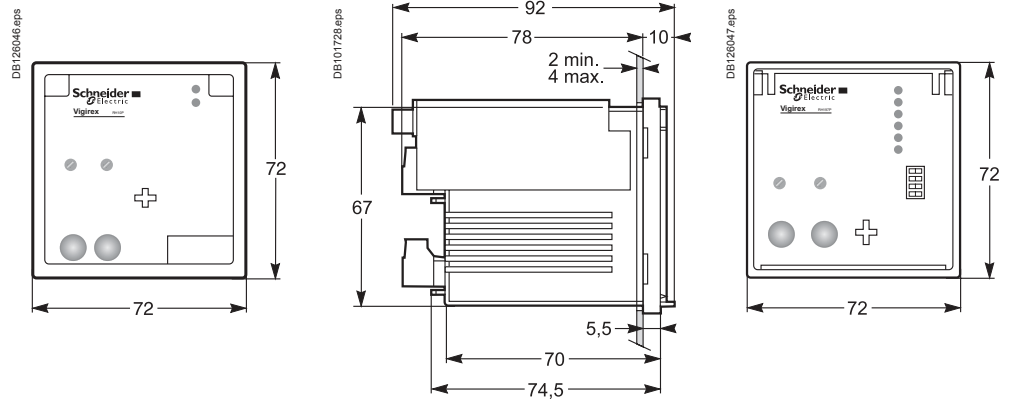

## RHUs, RHU and RMH

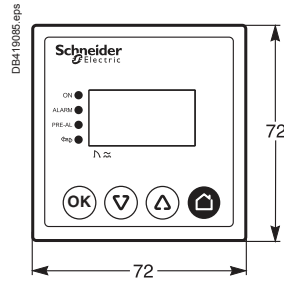
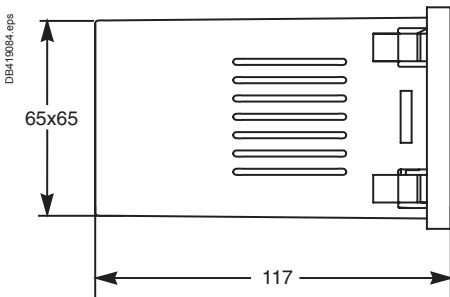

## Door cutout

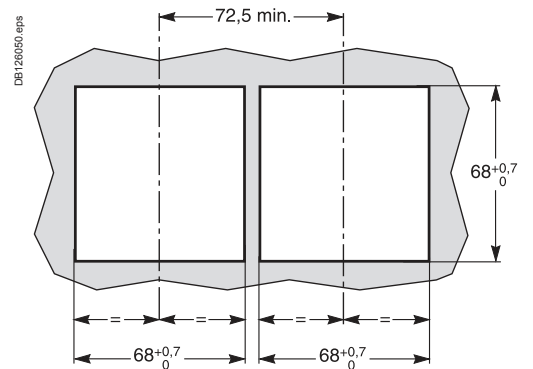

## DIN rail mounting only

### RM12T

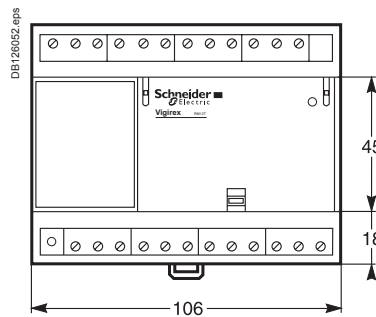
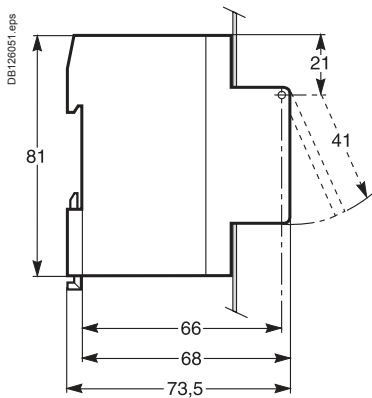

## Door cutout

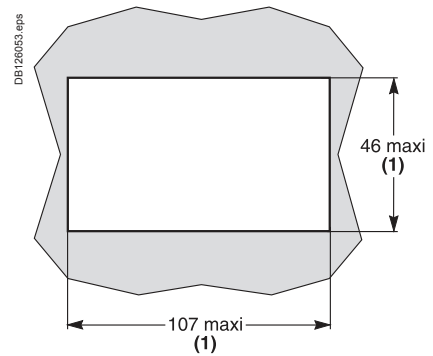

(1) For IP4 requirements.

### TA30 and PA50 toroids

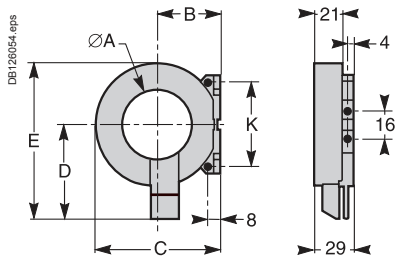

Secured to the back of the relay

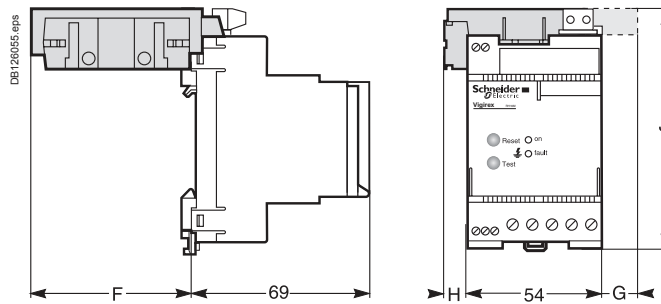

Type	$\varnothing A$	B	C	D	E	F	G	H	J	K
TA30	30	31	60	53	82	59	-	13	97	50
PA50	50	45	88	66	108	86	20	14	98	60

### IA80, MA120, SA200 and GA300 toroids

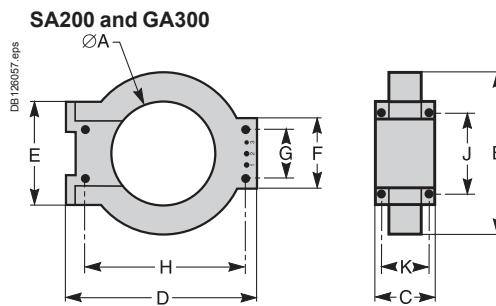
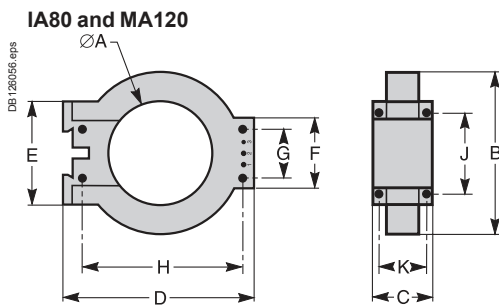

Type	$\varnothing A$	B	C	D	E	F	G	H	J	K
IA80	80	122	44	150	80	55	40	126	65	35
MA120	120	164	44	190	80	55	40	166	65	35
SA200	196	256	46	274	120	90	60	254	104	37
GA300	291	360	46	390	120	90	60	369	104	37

# TOA split toroids and rectangular sensors

## TOA80 and TOA120 toroids

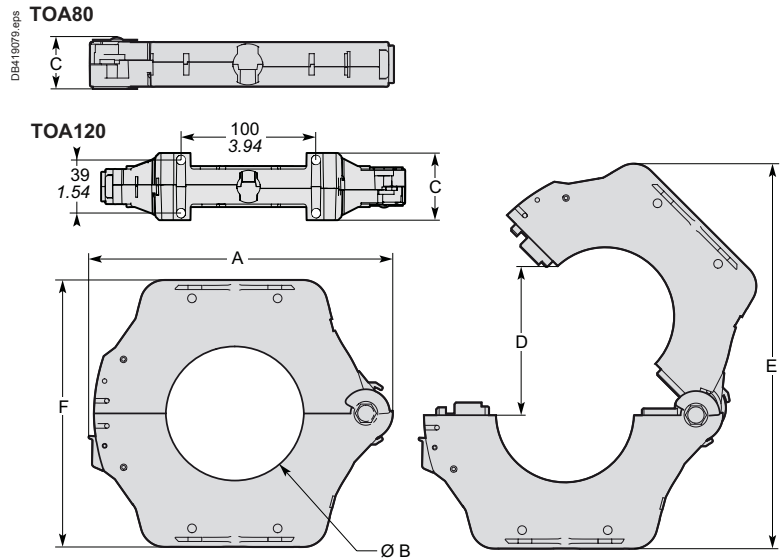

Type	Dimensions (mm)					
	A	ØB	C	D	E	F
TOA80	177	80	28	108	235	156
TOA120	225	120	50	150	303	205

## Rectangular sensors

L1: frame 280 x 115 mm

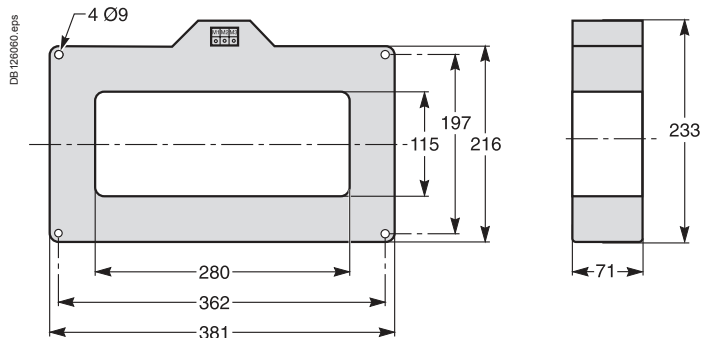

L2: frame 470 x 160 mm

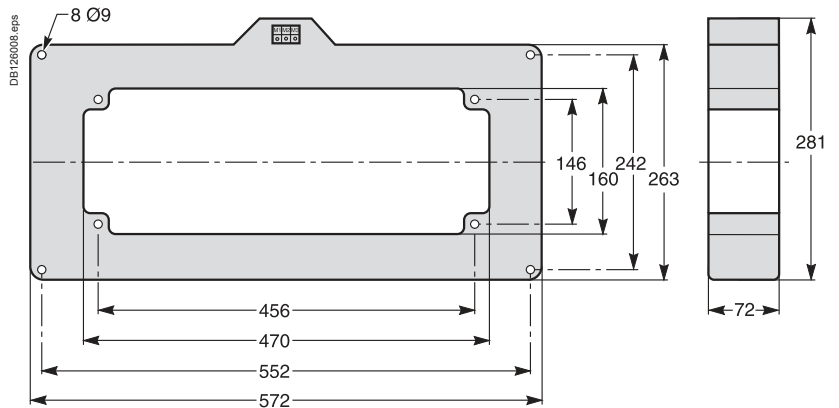



---

<i>Functions and characteristics</i>	A-1
<i>Installation recommendations</i>	B-1
<i>Dimensions and connection</i>	C-1

## **Wiring diagrams**

RH10, RH21, RH68, RH86 and RH99M RH10, RH21, RH86 and RH99P	D-2
RH86, RH99 monitor	D-4
RH197M with MX shunt release	D-5
RH197M with MN undervoltage release	D-6
RH197P with MX shunt release	D-7
RH197P with MN undervoltage release	D-8
RHUs and RHU	D-9
RMH	D-10
Communication bus, test and remote reset functions, power supply	D-11
<i>Additional characteristics</i>	E-1
<i>Catalogue numbers</i>	F-1

# Wiring diagrams

RH10, RH21, RH68, RH86 and RH99M

RH10, RH21, RH86 and RH99P

Wiring for optimum continuity of service

## RH10M, RH21M, RH68M, RH86M and RH99M wiring with MX shunt release

All diagrams are shown with circuits de-energised, all devices open and relays in released position.

L<sub>1</sub>: lamp

MX: shunt release

Q<sub>1</sub>: circuit breaker protecting the main circuit

Q<sub>2</sub>: DPN circuit breaker

**RH10M, RH21M, RH68M, RH86M and RH99M:**

- A<sub>1</sub>-A<sub>2</sub>: auxiliary power supply
- T<sub>1</sub>-T<sub>2</sub>: A or TOA type toroid or rectangular sensor (if IΔn ≥ 500 mA)
- 11-14: "voltage-presence" contact
- 26-25: relay test
- 27-25: "fault" reset
- 31-32-34: "fault" contact.

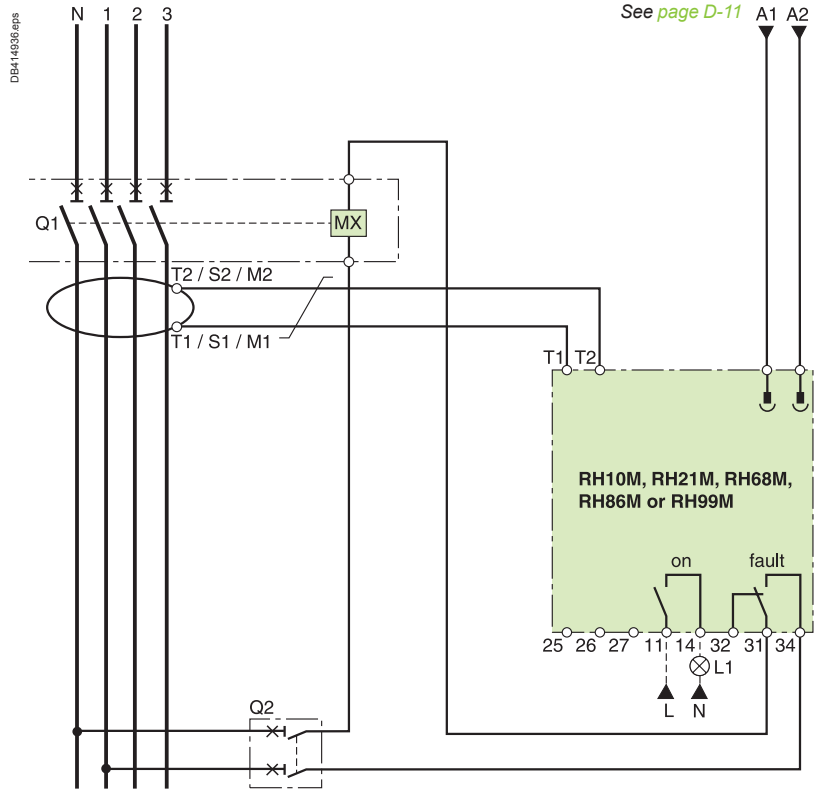

See page D-11

**Note:** for the RH99 earth leakage monitor use the "fault" contact 31, 32, 34.

## RH10P, RH21P, RH86P and RH99P wiring with MX shunt release

L<sub>1</sub>: lamp

MX: shunt release

Q<sub>1</sub>: circuit breaker protecting the main circuit

Q<sub>2</sub>: DPN circuit breaker

**RH10P, RH21P, RH86P and RH99P:**

- A<sub>1</sub>-A<sub>2</sub>: auxiliary power supply
- T<sub>1</sub>-T<sub>2</sub>: A or TOA type toroid or rectangular sensor (if IΔn ≥ 500 mA)
- 11-14: "voltage-presence" contact
- 26-25: relay test
- 27-25: "fault" reset
- 31-32-34: "fault" contact.

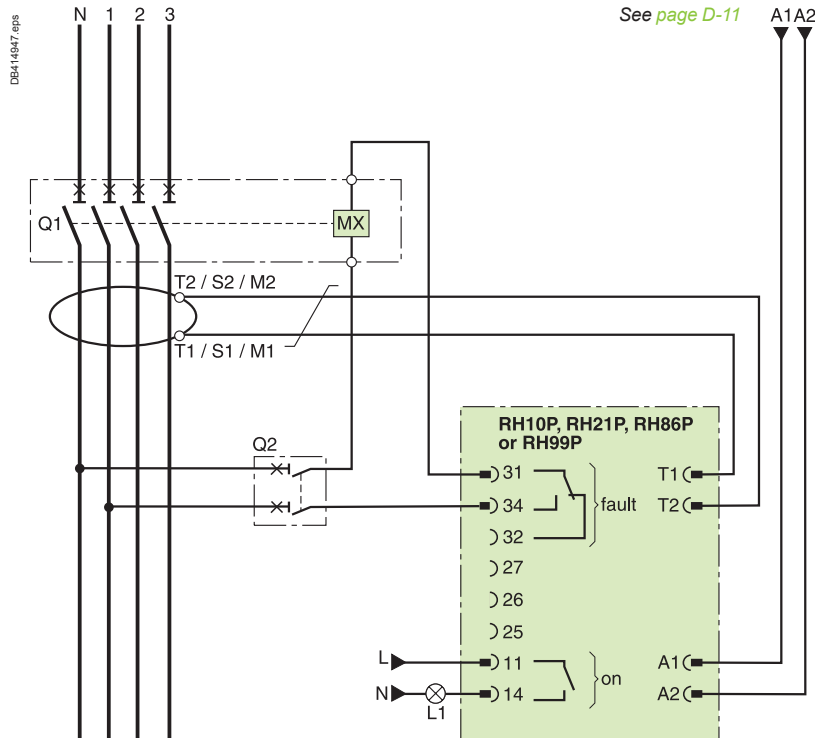

See page D-11

**Note:** for the RH99 earth leakage monitor use the "fault" contact 31, 32, 34.

# Wiring for optimum safety

## RH10M, RH21M, RH68M, RH86M and RH99M wiring with MN undervoltage release

All diagrams are shown with circuits de-energised, all devices open and relays in released position.

- MN:** undervoltage release  
**Q<sub>1</sub>:** circuit breaker protecting the main circuit  
**Q<sub>2</sub>:** DPN circuit breaker
- RH10M, RH21M, RH68M, RH86M and RH99M:**
- A<sub>1</sub>-A<sub>2</sub>: auxiliary power supply
  - T<sub>1</sub>-T<sub>2</sub>: A or TOA type toroid or rectangular sensor (if  $I_{\Delta n} \geq 500$  mA)
  - 11-14: "voltage-presence" contact
  - 26-25: relay test
  - 27-25: "fault" reset
  - 31-32-34: "fault" contact.

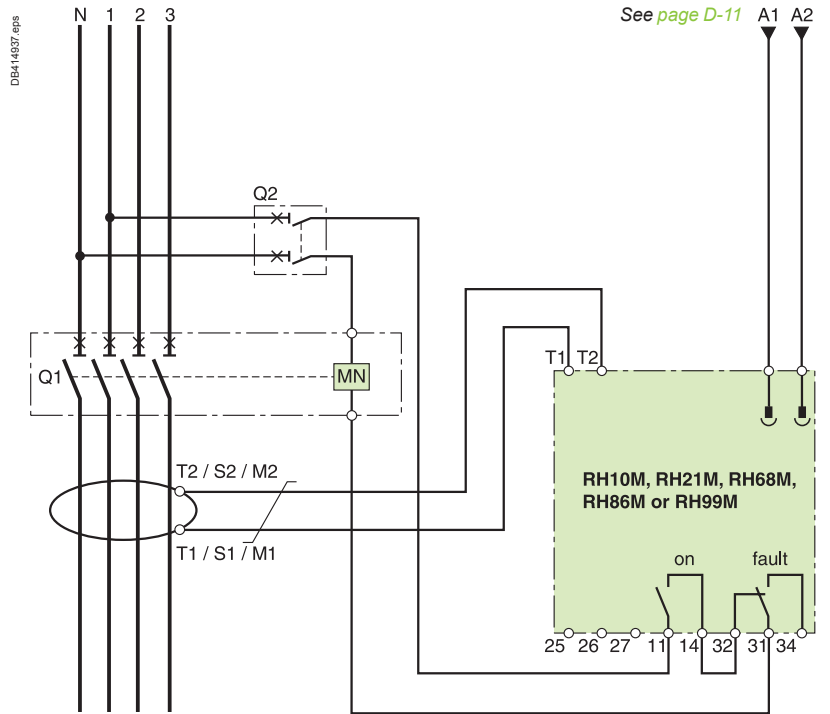

**Note:** for the RH99 earth leakage monitor use the "fault" contact 31, 32, 34.

## RH10P, RH21P, RH86P and RH99P wiring with MN undervoltage release

- MN:** undervoltage release  
**Q<sub>1</sub>:** circuit breaker protecting the main circuit  
**Q<sub>2</sub>:** DPN circuit breaker
- RH10MP, RH21P, RH86P and RH99P:**
- A<sub>1</sub>-A<sub>2</sub>: auxiliary power supply
  - T<sub>1</sub>-T<sub>2</sub>: A or TOA type toroid or rectangular sensor (if  $I_{\Delta n} \geq 500$  mA)
  - 11-14: "voltage-presence" contact
  - 26-25: relay test
  - 27-25: "fault" reset
  - 31-32-34: "fault" contact.

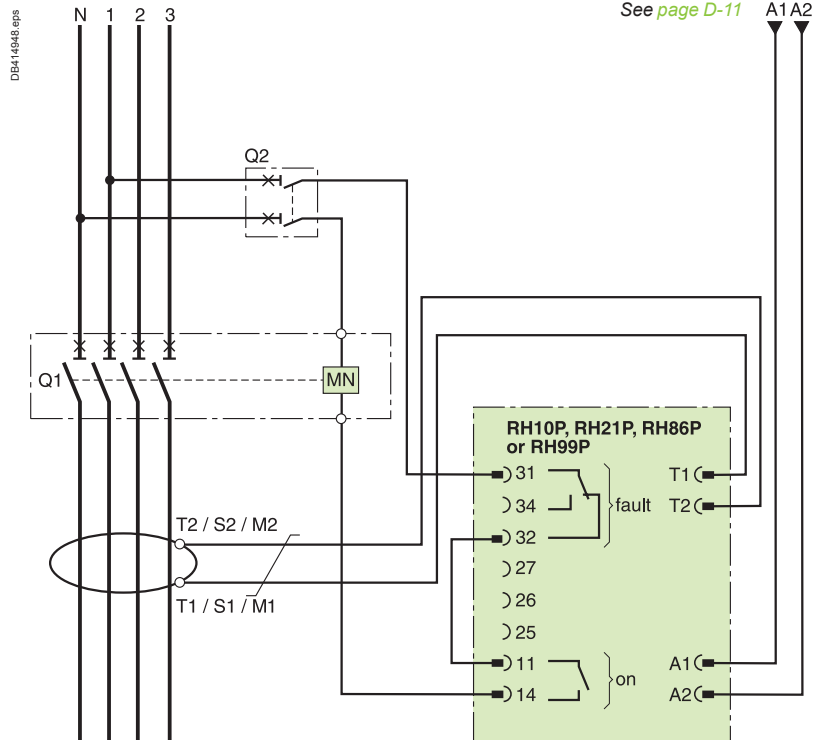

**Note:** for the RH99 earth leakage monitor, use the "fault" contact 31, 32, 34.

# Wiring diagrams

## RH86, RH99 monitor Auto-reclosing application for unattended stations

### RH86M, RH99M monitor wiring with ATm auto-reclosing controller

All diagrams are shown with circuits de-energised, all devices open and relays in released position.

**ATm3:** auto-reclosing controller

**H:** red light

**MT:** motor mechanism module

**MX:** shunt release

**Q<sub>1</sub>:** circuit breaker protecting the main circuit

**Q<sub>4</sub> to Q<sub>6</sub>:** DPN circuit breakers

**RH86M, RH99M monitor:**

■ **A<sub>1</sub>-A<sub>2</sub>:** auxiliary power supply

■ **T<sub>1</sub>-T<sub>2</sub>:** A or TOA type toroid or rectangular sensor

(if  $I_{\Delta n} \geq 500$  mA)

■ **11-14:** "voltage-presence" contact

■ **26-25:** relay test

■ **27-25:** "fault" reset

■ **31-32-34:** "fault" contact

**S<sub>1</sub> et S<sub>2</sub>:** single-pole switch

**SD:** auxiliary fault indication contact

**T:** sensor.

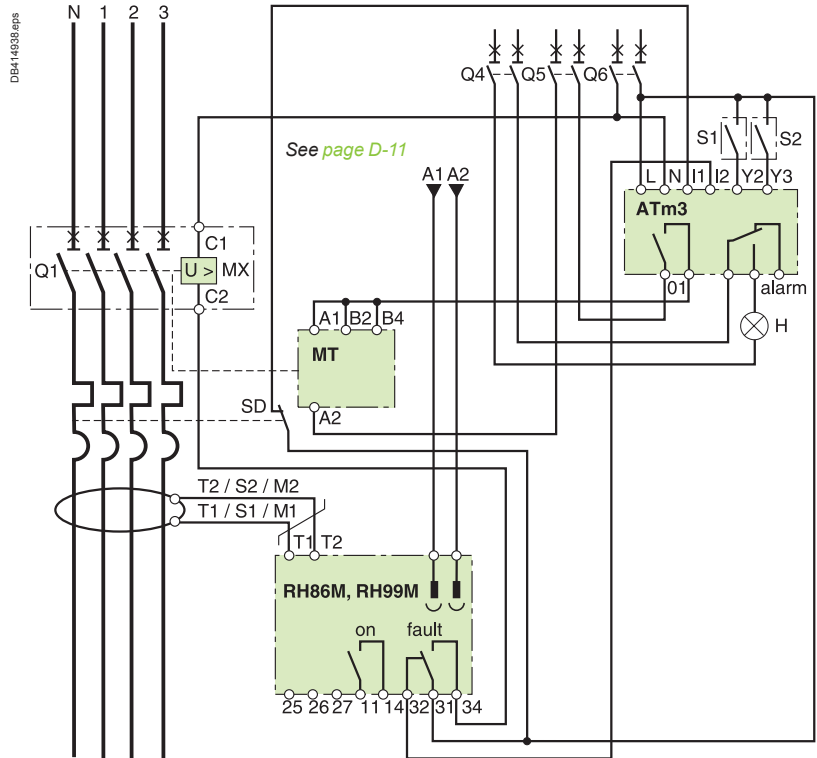

### RH86P, RH99P monitor wiring with ATm auto-reclosing controller

**ATm3:** auto-reclosing controller

**H:** red light

**MT:** motor mechanism module

**MX:** shunt release

**Q<sub>1</sub>:** circuit breaker protecting the main circuit

**Q<sub>4</sub> to Q<sub>6</sub>:** DPN circuit breakers

**RH86P, RH99P monitor:**

■ **A<sub>1</sub>-A<sub>2</sub>:** auxiliary power supply

■ **T<sub>1</sub>-T<sub>2</sub>:** A or TOA type toroid or rectangular sensor

(if  $I_{\Delta n} \geq 500$  mA)

■ **11-14:** "voltage-presence" contact

■ **26-25:** relay test

■ **27-25:** "fault" reset

■ **31-32-34:** "fault" contact

**S<sub>1</sub> et S<sub>2</sub>:** single-pole switch

**SD:** auxiliary fault indication contact

**T:** sensor.

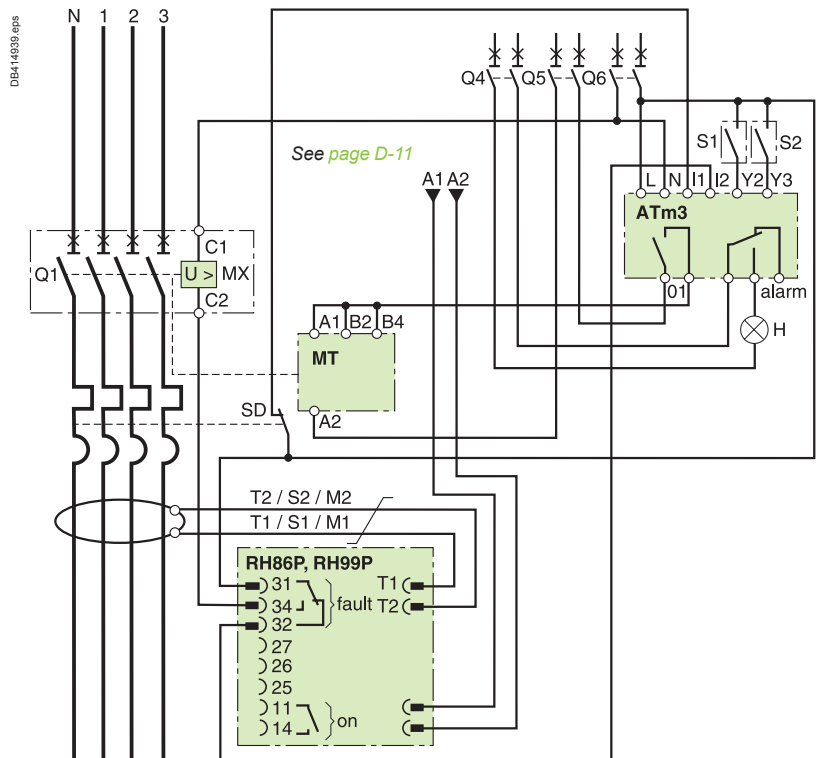

### Additional information

- the SD auxiliary contact is mandatory
- manual operation of the MT motorised operating mechanism always overrides the ATm3 auto-reclosing controller
- use a single power supply (L/N) for all inputs (I), the ATm3 and the MX auxiliary.

# RH197M with MX shunt release

## RH197M wiring for optimum continuity of service

All diagrams are shown with circuits de-energised, all devices open and relays in released position.

### Switch setting:



**L1:** lamp and audio alarm  
**MX:** shunt release  
**Q<sub>1</sub>:** circuit breaker protecting the main circuit  
**Q<sub>2</sub>:** DPN circuit breaker

### RH197M:

- A<sub>1</sub>-A<sub>2</sub>: auxiliary power supply
- T<sub>1</sub>-T<sub>2</sub>: A or TOA type toroid or rectangular sensor (if  $I\Delta n \leq 500$  mA)
- 41-44: "alarm contact"
- 26-25: relay test
- 27-25: "fault" reset
- 31-32-34: "fault" contact

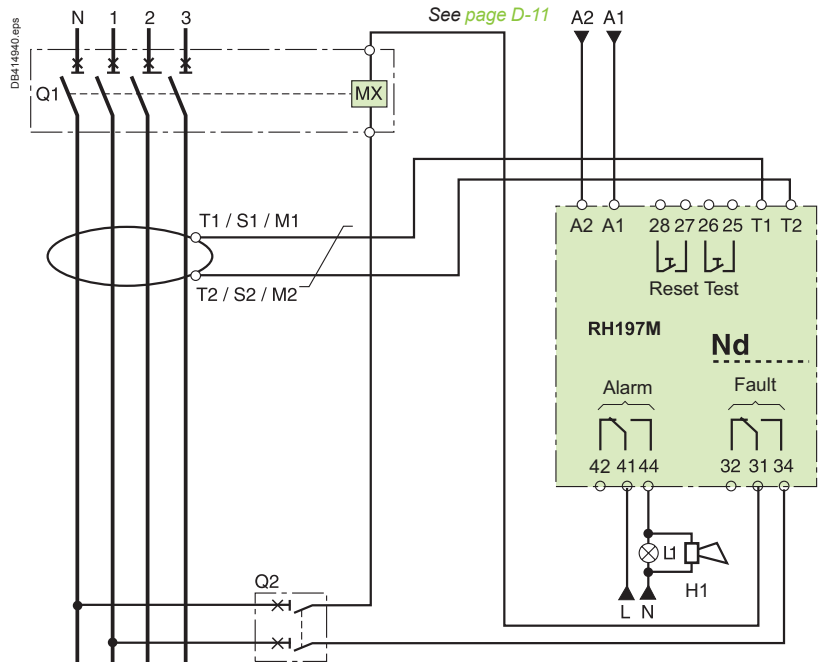

## RH197M wiring for optimum safety

All diagrams are shown with circuits de-energised, all devices open and relays in released position.

### Switch setting:



### Warning

The supply for A1-A2 must be different from that of the MX shunt release.

**L1:** lamp and audio alarm  
**MX:** shunt release  
**Q<sub>1</sub>:** circuit breaker protecting the main circuit  
**Q<sub>2</sub>:** DPN circuit breaker

### RH197M:

- A<sub>1</sub>-A<sub>2</sub>: auxiliary power supply
- T<sub>1</sub>-T<sub>2</sub>: A or TOA type toroid or rectangular sensor (if  $I\Delta n \leq 500$  mA)
- 41-44: "alarm contact"
- 26-25: relay test
- 27-25: "fault" reset
- 31-32-34: "fault" contact.

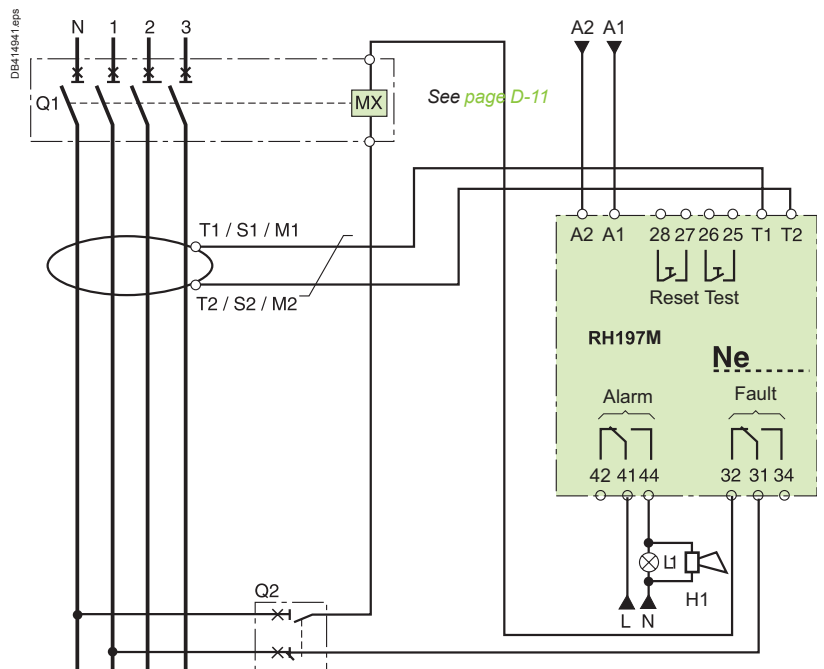

### RH197M wiring for optimum continuity of service

All diagrams are shown with circuits de-energised, all devices open and relays in released position.

**Switch setting:**



- L1:** lamp and audio alarm
- MN:** undervoltage release
- Q<sub>1</sub>:** circuit breaker protecting the main circuit
- Q<sub>2</sub>:** DPN circuit breaker

**RH197M:**

- **A<sub>1</sub>-A<sub>2</sub>:** auxiliary power supply
- **T<sub>1</sub>-T<sub>2</sub>:** A or TOA type toroid or rectangular sensor (if  $I_{\Delta n} < 500 \text{ mA}$ )
- **41-44:** "alarm contact"
- **26-25:** relay test
- **27-25:** "fault" reset
- **31-32-34:** "fault" contact.

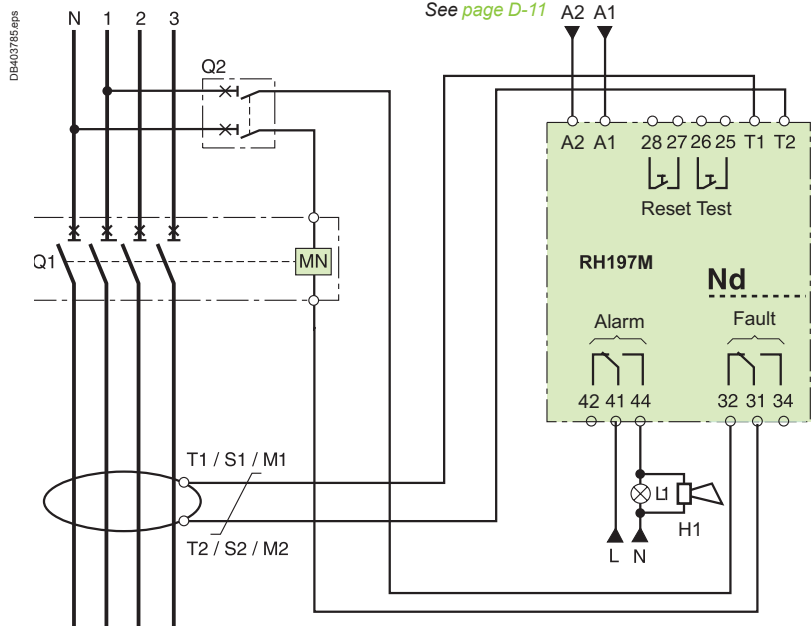

### RH197M wiring for optimum safety

All diagrams are shown with circuits de-energised, all devices open and relays in released position.

**Switch setting:**



- L1:** lamp and audio alarm
- MN:** undervoltage release
- Q<sub>1</sub>:** circuit breaker protecting the main circuit
- Q<sub>2</sub>:** DPN circuit breaker

**RH197M:**

- **A<sub>1</sub>-A<sub>2</sub>:** auxiliary power supply
- **T<sub>1</sub>-T<sub>2</sub>:** A or TOA type toroid or rectangular sensor (if  $I_{\Delta n} \leq 500 \text{ mA}$ )
- **41-44:** "alarm contact"
- **26-25:** relay test
- **27-25:** "fault" reset
- **31-32-34:** "fault" contact.

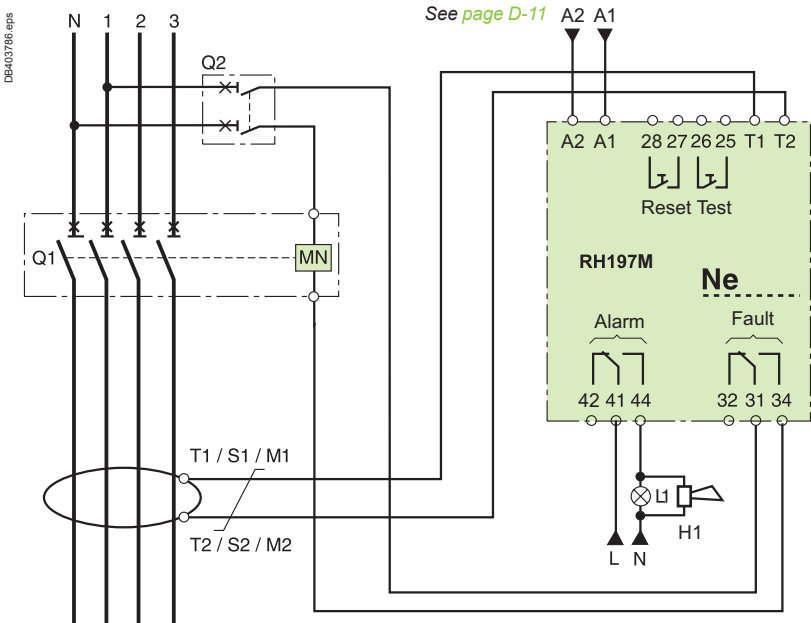

# RH197P with MX shunt release

## RH197P wiring for optimum continuity of service

All diagrams are shown with circuits de-energised, all devices open and relays in released position.

### Switch setting:



- L1:** lamp and audio alarm
- MX:** shunt release
- Q<sub>1</sub>:** circuit breaker protecting the main circuit
- Q<sub>2</sub>:** DPN circuit breaker
- RH197P:**
  - A<sub>1</sub>-A<sub>2</sub>: auxiliary power supply
  - T<sub>1</sub>-T<sub>2</sub>: A or TOA type toroid or rectangular sensor (if IΔn ≤ 500 mA)
  - 41-44: "alarm contact"
  - 26-25: relay test
  - 27-25: "fault" reset
  - 31-32-34: "fault" contact

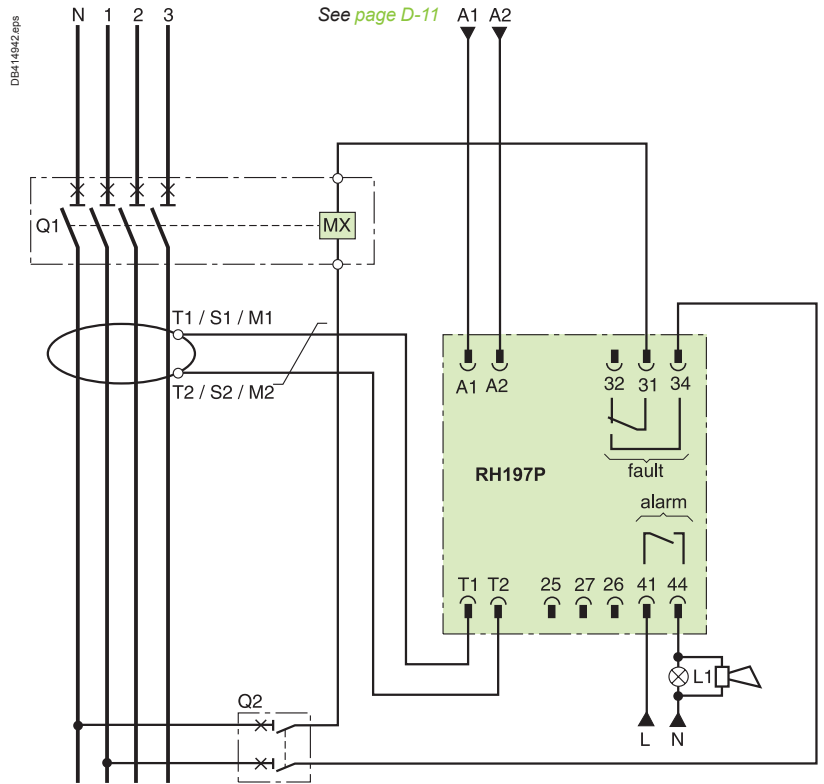

## RH197P wiring for optimum safety

All diagrams are shown with circuits de-energised, all devices open and relays in released position.

### Switch setting:



### Warning

The supply for A1-A2 must be different from that of the MX shunt release.

- L1:** lamp and audio alarm
- MX:** shunt release
- Q<sub>1</sub>:** circuit breaker protecting the main circuit
- Q<sub>2</sub>:** DPN circuit breaker
- RH197P:**
  - A<sub>1</sub>-A<sub>2</sub>: auxiliary power supply
  - T<sub>1</sub>-T<sub>2</sub>: A or TOA type toroid or rectangular sensor (if IΔn ≤ 500 mA)
  - 41-44: "alarm contact"
  - 26-25: relay test
  - 27-25: "fault" reset
  - 31-32-34: "fault" contact.

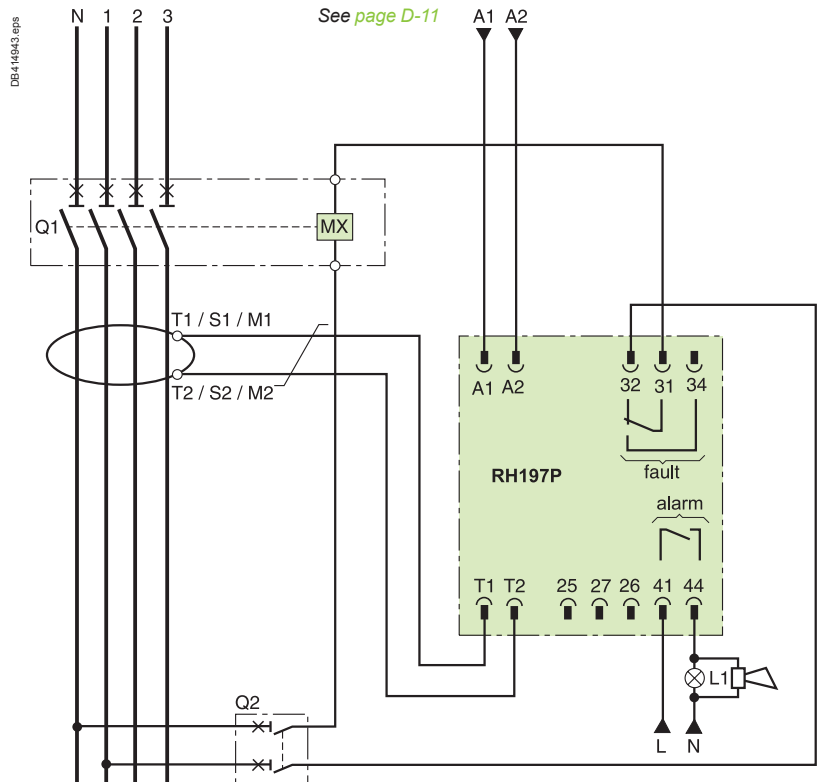

### RH197P wiring for optimum continuity of service

All diagrams are shown with circuits de-energised, all devices open and relays in released position.

**Switch setting:**



- L1: lamp and audio alarm
- MN: undervoltage release
- Q<sub>1</sub>: circuit breaker protecting the main circuit
- Q<sub>2</sub>: DPN circuit breaker
- RH197P:**
  - A<sub>1</sub>-A<sub>2</sub>: auxiliary power supply
  - T<sub>1</sub>-T<sub>2</sub>: A or TOA type toroid or rectangular sensor (if I<sub>Δn</sub> < 500 mA)
  - 41-44: "alarm contact"
  - 26-25: relay test
  - 27-25: "fault" reset
  - 31-32-34: "fault" contact.

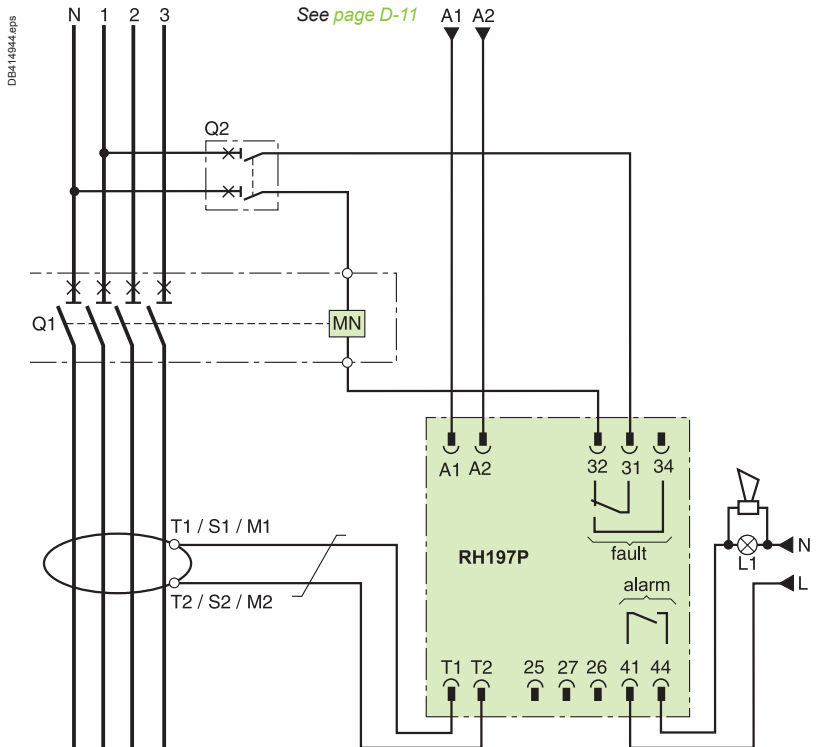

### RH197P wiring for optimum safety

All diagrams are shown with circuits de-energised, all devices open and relays in released position.

**Switch setting:**



- L1: lamp and audio alarm
- MN: undervoltage release
- Q<sub>1</sub>: circuit breaker protecting the main circuit
- Q<sub>2</sub>: DPN circuit breaker
- RH197P:**
  - A<sub>1</sub>-A<sub>2</sub>: auxiliary power supply
  - T<sub>1</sub>-T<sub>2</sub>: A or TOA type toroid or rectangular sensor (if I<sub>Δn</sub> ≤ 500 mA)
  - 41-44: "alarm contact"
  - 26-25: relay test
  - 27-25: "fault" reset
  - 31-32-34: "fault" contact.

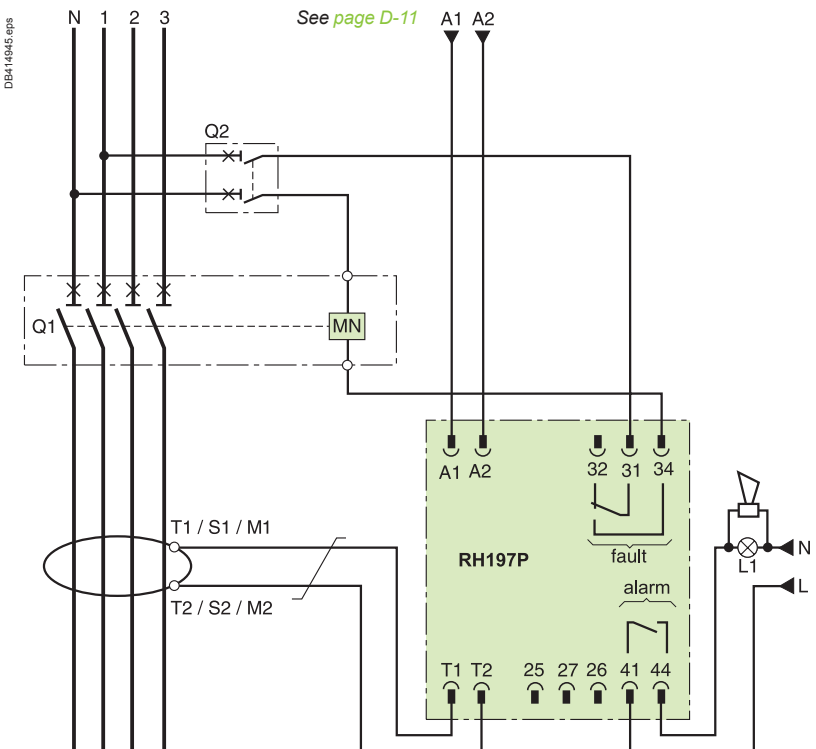

# RHUs and RHU

## RHUs and RHU wiring with MX shunt release: optimum continuity of service

All diagrams are shown with circuits de-energised, all devices open and relays in released position.

- $L_1$ : lamp and audio alarm  
 $L_2$ : lamp  
**MX**: shunt release  
 $Q_1$ : circuit breaker protecting the main circuit  
 $Q_2$ : DPN circuit breaker
- RHUs and RHU:**
- $A_1$ - $A_2$ : auxiliary power supply
  - $T_1$ - $T_2$ : A or TOA type toroid or rectangular sensor (if  $I\Delta n \geq 0.5 A$ )
  - 11-14: "voltage-presence" contact
  - 26-25: relay test
  - 27-25: "fault" reset
  - 31-32-34: "fault" contact
  - 41-44: "alarm contact".

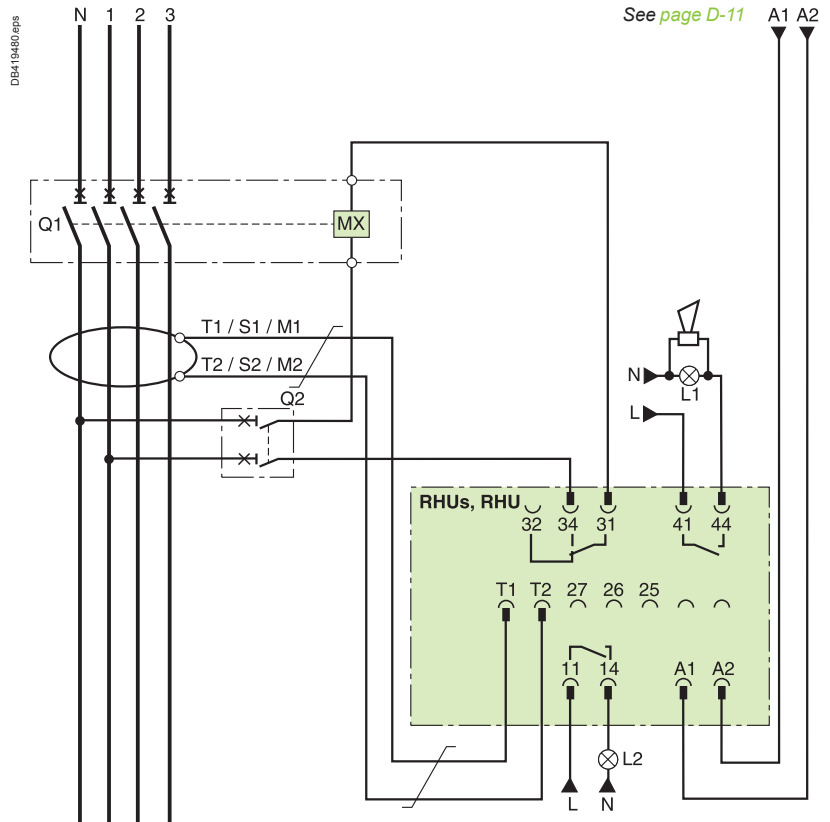

(1) RHU only.

## RHUs and RHU wiring with MN undervoltage release: optimum safety

- $L_1$ : amp and audio alarm  
**MN**: undervoltage release  
 $Q_1$ : circuit breaker protecting the main circuit  
 $Q_2$ : DPN circuit breaker
- RHUs and RHU:**
- $A_1$ - $A_2$ : auxiliary power supply
  - $T_1$ - $T_2$ : A or TOA type toroid or rectangular sensor (if  $I\Delta n \geq 0.5 A$ )
  - 11-14: "voltage-presence" contact
  - 26-25: relay test
  - 27-25: "fault" reset
  - 31-32-34: "fault" contact
  - 41-44: "alarm contact".

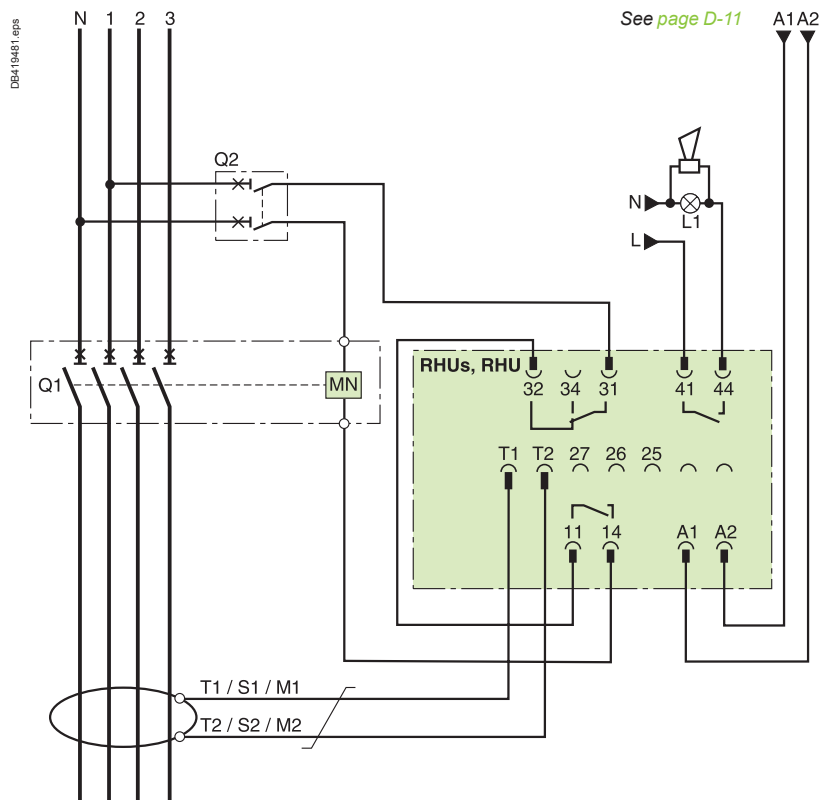

(1) RHU only.

### RMH wiring with RM12T multiplexer

All diagrams are shown with circuits de-energised, all devices open and relays in released position.

DB419482.eps

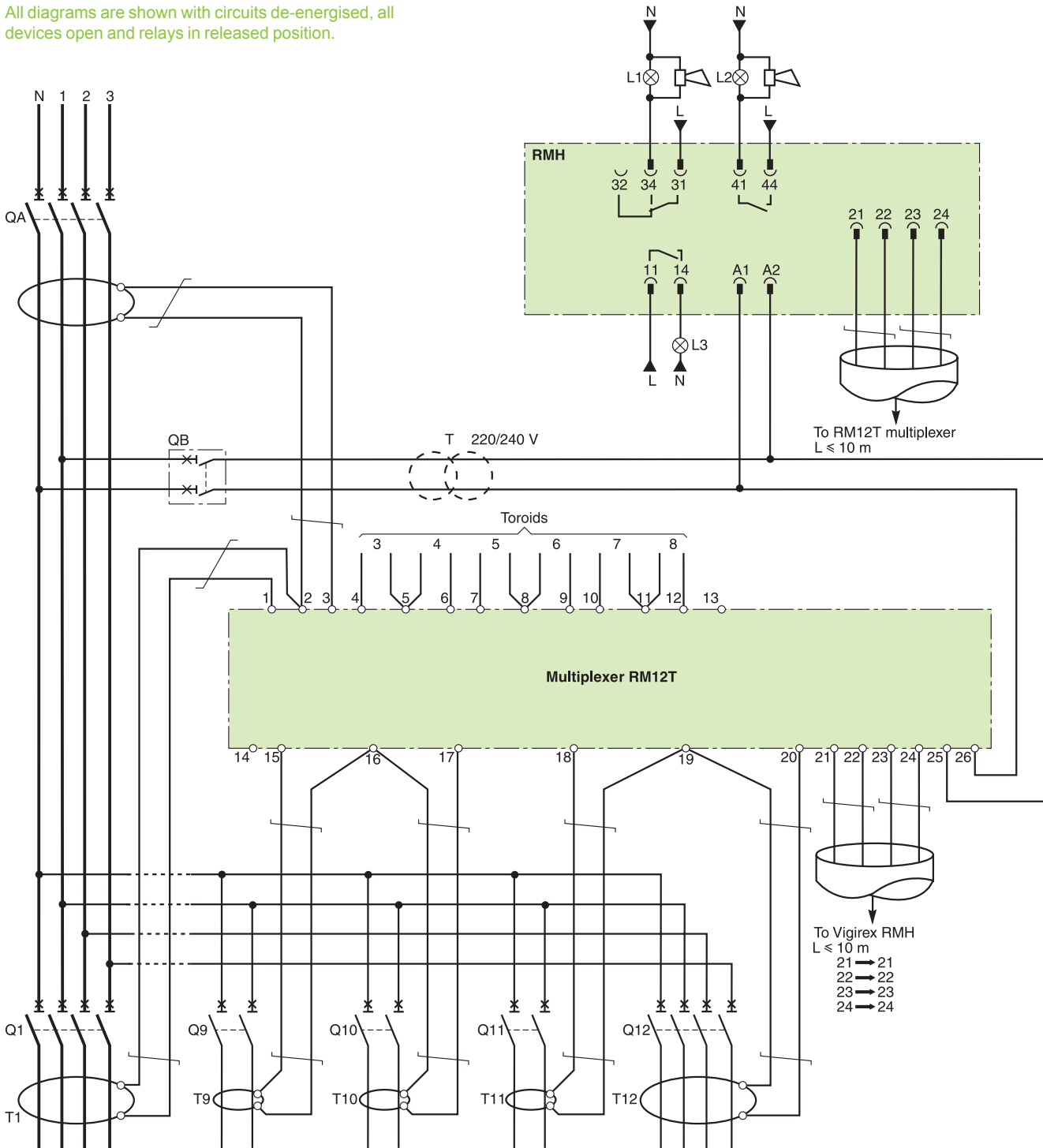

$L_1, L_2$ : lamp and audio alarm  
 $L_3$ : lamp

$Q_A$ : switchboard incoming circuit breaker for the main circuit  
 $Q_B$ : circuit breaker protecting the RMH and RM12T power supply circuit  
 $Q_1$  to  $Q_{12}$ : circuit breakers on main outgoing circuits 1 to 12  
 $T$ : transformer with 220/240 V secondary (if required), rating  $\geq 4$  VA  
 $T_1$  to  $T_{12}$ : earth leakage current measurement toroids for circuits 1 to 12 (or rectangular sensor if  $I_{\Delta n} \geq 0.5$  A).

**RM12T multiplexer**

- terminals 1 to 12 and 15 to 20: connection of toroids
- terminals 21 to 24: connection of RMH earth leakage monitor
- terminals 25 to 26: auxiliary power supply.

**RMH earth leakage monitor**

- $A_1, A_2$ : auxiliary power supply
- 11-14: "voltage-presence" contact
- 21 to 24: connection of RM12T multiplexer
- 31-32-34: "alarm" contact
- 41-44: "pre-alarm" contact.

# Communication bus, test and remote reset functions, power supply

## Connection of test and remote reset functions.

### Cable

The cable must not exceed 10 m in length.  
Use a cable with 3 twisted wires.

### Contacts

Use pushbuttons with low-level contacts suitable for the minimum load of 1 mA at 4 V.

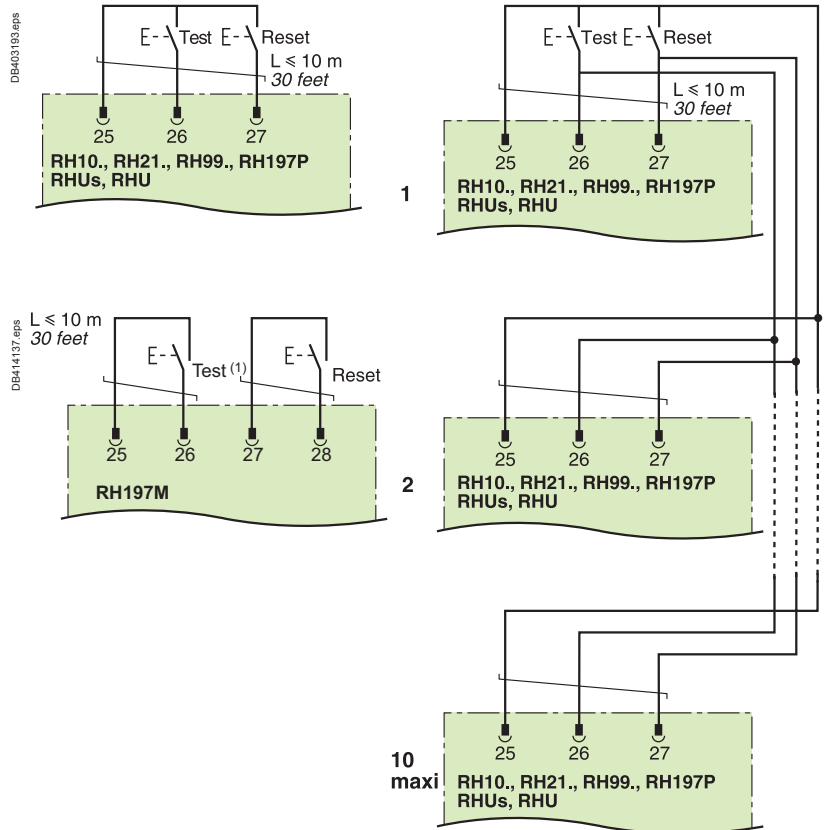

(1) Not available on DC version / Hold on for a time equivalent to the time delay setting for others versions.

## Connection of RH10, RH21, RH99, RH197, RHUs and RHU power supply

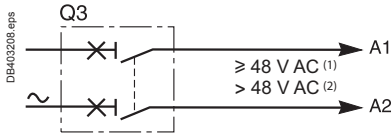

- (1) RH10, RH21 and RH99.
- (2) RH197.

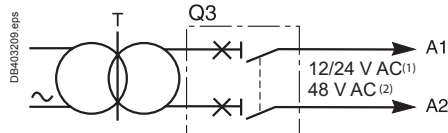

- T : class 2 isolation transformer mandatory:
- for  $V_{A1,A2} \leq 24$  V AC for RH10, RH21 and RH99
  - for  $V_{A1,A2} = 48$  V AC for RH197P

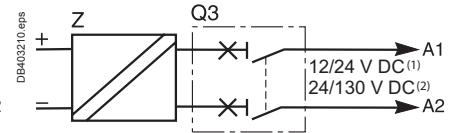

The DC power supply must be galvanically isolated from the AC power system.



---

<i>Functions and characteristics</i>	A-1
<i>Installation recommendations</i>	B-1
<i>Dimensions and connection</i>	C-1
<i>Wiring diagrams</i>	D-1
<b>Definitions and glossary</b>	<b>E-2</b>
<hr/>	
<b>Protection using Vigirex RCDs</b>	
Protection of persons	E-4
System earthing arrangements	E-7
Protection of property: fire hazards	E-10
Disturbances in distribution systems	E-12
<hr/>	
<b>Vigirex devices</b>	
RCD operating principle	E-14
Residual-current measurements	E-16
Implementation	E-24
Applications	E-28
Questions and answers	E-34
<hr/>	
<b>Leakage-current monitoring using RCDs</b>	<b>E-37</b>
<hr/>	
<b>Tripping curves and frequency filtering</b>	
RH10, RH21, RH68, RH86 and RH99	E-43
RH197M	E-44
RH197P	E-45
RHUs and RHU	E-46
<i>Catalogue numbers</i>	F-1

**Earth:** the conducting mass of the Earth, whose electric potential at any point is conventionally taken as zero.

**Earth electrode:** conductive part that can be incorporated in a particular conductive environment, for example concrete or coke in electrical contact with earth.

**Earth-fault current:** current flowing to earth due to an insulation fault.

**Earthing resistance** or in fact the *“overall earthing resistance”*: resistance between the main earthing terminal (terminal or bar to which the PE protective conductors are connected) and earth.

**Earth-leakage current:** current flowing from the live parts to earth or extraneous conductive parts in the absence of an insulation fault.

**Equipotential bonding:** electrical connection putting various exposed conductive parts and extraneous conductive parts at a substantially equal potential.

**Exposed conductive part:** a conductive part which can readily be touched and which is not normally live, but which may become live under fault conditions.

**Intentional leakage current:** current flowing to earth or extraneous conductive parts via intentionally installed components (resistors or capacitors), in the absence of an insulation fault.

**Isolated system:** system with an autonomous supply of power, not connected to utility power.

**Natural leakage current:** current flowing to earth or extraneous conductive parts via the insulation, in the absence of an insulation fault.

**Protective conductor PE:** a conductor required by some measures for protection against electric shock for electrically connecting any of the following parts: exposed conductive parts, extraneous conductive parts, main earthing terminal, earth electrode, earthed point of the source or artificial neutral, metallic parts of the building structure that are not part of an electrical device, protected by equipotential bonding, if they are simultaneously accessible.

**Residual current:** vector sum of the instantaneous values of the current in all the live conductors of a circuit at a given point in an electrical installation.

**Zero volt (reference):** measurement reference point for differences in potential (voltage measurements, often in monitoring circuits).

Acronym/ French	Acronym/ English	Definition
DDR	RCD	Residual-current device. A mechanical device or set of devices intended to open contacts when the residual current reaches a set value under the specified conditions.
DPCC	SCPD	Short-circuit protective device.
dv/dt		Variation in the voltage as a function of time (term generally reserved for fast variations, on the order of 1000 V/ms).
IGBT	IGBT	Insulated gate bipolar transistor.
IT	IT	In the IT system, all the live parts are either isolated from earth or connected to earth at one point via an impedance. The exposed conductive parts of the electrical installation are earthed.
Filtre RFI RFI	RFI filter	An RFI filter limits radio-frequency disturbances. RFI: Radio-frequency interference.
SLT	System earthing arrangement	System earthing arrangement (sometimes referred to as the earthing system).
TN	TN	In the TN system, a point in the supply system is directly connected to earth. The exposed conductive parts of the electrical installation are connected to this point via protective conductors.
TN-C	TN-C	The TN-C system is a TN system in which the neutral and protection functions are combined in a single conductor (PEN) throughout the installation.
TN-C-S	TN-C-S	The TN-C-S system is a TN system in which the neutral and protection functions are combined in a single conductor (PEN) in a part of the installation (upstream of the TN-S system).
TN-S	TN-S	The TN-S system is a TN system in which a protective conductor separate from the neutral is used throughout the installation.
TT	TT	In the TT system, a point in the supply system is directly connected to earth. The exposed conductive parts of the electrical installation are connected to earth electrodes that are electrically separate from that for the supply system.
CEM / EM	EMC / EM	Electromagnetic compatibility (EMC) is the aptitude of a device or system to operate in its electromagnetic (EM) environment satisfactorily and without itself producing unacceptable electromagnetic disturbances for its environment.
GFP	GFP	Ground fault protection System used to measure zero-sequence currents that flow if a fault occurs in the TN-S system (used in the United States).
NEC	NEC	National electrical code Installation standard published by an association in the United States.
THDI	THDI	Total harmonic distortion of current.
Valeur efficace	RMS	Root mean square value.

The physiological effects of electric current on people (muscle tetanisation, internal and external burns, ventricular fibrillation and cardiac arrest) depend on a number of different factors, namely the physiological characteristics of the human being, the environment (humid or dry, for example) and the characteristics of the current flowing through the body.

### IEC standard 60479

The experts of the International Electrotechnical Committee (IEC) have studied the problem in view of harmonising opinions on the worldwide level and establishing a standard (IEC 60479) that scientifically and practically determines the effects of electric current on the human body.

#### Importance of the amperage

The diagram below presents the effect of alternating current on the human body.

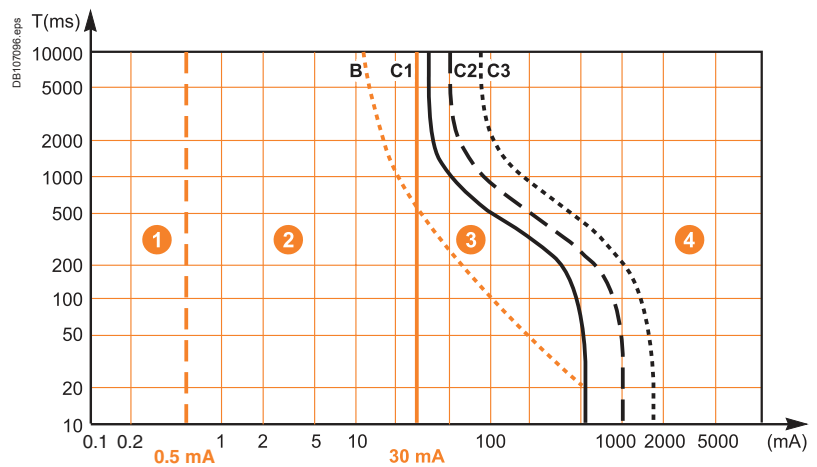

Time/current zone (IEC 60 479-1).

The risk of the person not letting go, breathing arrest or cardiac fibrillation increases proportionally to the time the person is exposed to the electric current.

#### ■ Zone 1

- **0.5 mA** is the perception threshold. This corresponds to the perception of a current flowing through the body for an unlimited duration. The possible discomfort is not defined.

#### ■ Zone 2

there are no dangerous physiological effects up to the let-go threshold (line b).

#### ■ Zone 3 (between line b and curve c<sub>1</sub>)

there is generally no organic damage, but the discomfort felt by the person in this case is significant

**b - 10 mA** let-go threshold: current threshold at the asymptote of the "let-go curve" for an infinite time.

**c<sub>1</sub> - 30 mA** ventricular-fibrillation threshold: up to this threshold, there is no risk of ventricular fibrillation (i.e. no risk of cardiac arrest) for an infinite time.

#### ■ Zone 4 (to the right of curve c<sub>1</sub>)

in addition to the effects inflicted in zone 3, there may be physiological effects such as cardiac arrest, breathing arrest and severe burns. In particular, the probability of ventricular fibrillation is:

- approximately 5 %, between the curves c<sub>1</sub> and c<sub>2</sub>
- less than 50 % between the curves c<sub>2</sub> and c<sub>3</sub>
- greater than 50 % beyond curve c<sub>3</sub>.

### Importance of the current frequency

Standard IEC 60479-1 § 3 and -2 § 4 defines the sensitivity of the human body to fibrillation depending on the frequency of the current.

### Current thresholds depending on the frequency

Frequency (Hz)	Perception (mA)	Let-go (mA)	Fibrillation (mA)
DC	2	-	100
50	0.5	10	40
100	0.5	10	80
300	0.6	12	180
1000	1	17	560
3000	2	23	-
5000	4	32	-
10000	6	50	-
>10000	100	-	-

### Installation standard IEC 60364

#### Touch voltage/ disconnecting time

Standard IEC 60479 defines the effects of an electric current flowing through the human body.

- The installation standards IEC 60364 (NF C 15-100 in France), in chapter 4-41, establish the mandatory safety rules for low-voltage electrical installations:
  - by translating the **current / exposure time** values in the previous curve into a set of **touch voltage / contact time** values that must not be exceeded. The values depend on the environment conditions (humid or dry) in the installation
  - by defining the techniques and operational diagrams to be used to avoid (or manage) the dangerous voltages resulting from an insulation fault.
- They define the dangerous limit values UL for the touch voltage:
  - UL = 50 V for a dry environment (generally the case).
- As a result, there are two operating modes in a low-voltage installation:
  - operation with an operational voltage under the limit value, i.e. no particular action is required if an insulation fault occurs
  - operation with an operational voltage greater than the touch voltage (generally the case), where, if an insulation fault occurs, the dangerous part of the installation must be automatically disconnected within a given time limit (see the table below).

#### Maximum disconnecting time of protection device(s) (according to table 41A of standard IEC 60364)

Ph-N voltage (V)	AC current	DC current
$U_0 \leq 50$ V	5 s	5 s
$50$ V < $U_0 \leq 120$ V	0.8 s	5 s
$120$ V < $U_0 \leq 230$ V	0.4 s	5 s
$230$ V < $U_0 \leq 400$ V	0.2 s	0.4 s
$U_0 > 400$ V	0.1 s	0.1 s

The installation standards of specific countries interpret this table according to the applicable system earthing arrangement.

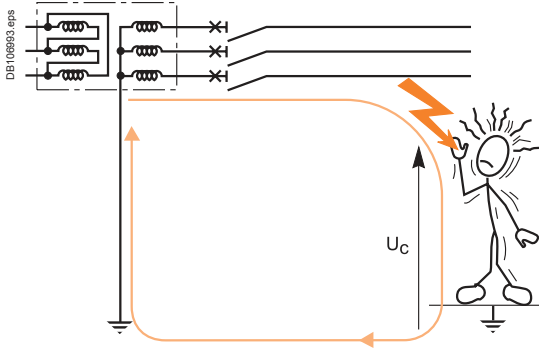

Direct contact.

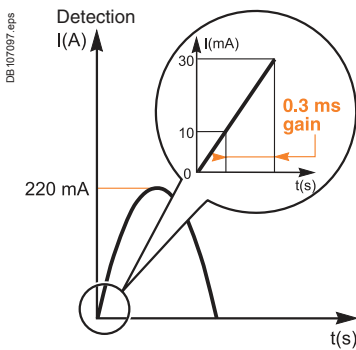

Comparison between 10 mA and 30 mA.

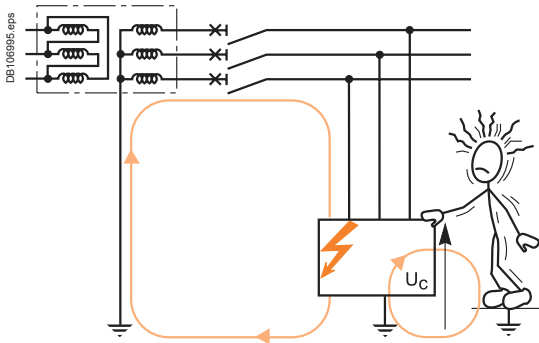

Indirect contact.

### Type of contact

The standards and regulations distinguish two types of potentially dangerous contacts and indicate the corresponding protection techniques.

■ **Direct contact:** contact of a person with live conductors (phase or neutral) or with conductive parts that are habitually live.

Protection against direct contact is normally provided by insulation of the live parts using barriers, screens or enclosures (as per standard IEC 60364-4-41 or NF C 15-100). These systems are preventive in nature and may fail. That is why additional protection is installed, in the form of a high-sensitivity RCD that automatically breaks the circuit. The operating threshold is set to 30 mA for AC current (IEC 60364-4-41 or NF C 15-100) and 60 mA for DC current.

The sensitivity of RC protection devices, designed to limit the current flowing through the body to a maximum of 30 mA, provides a very high level of safety and maintains a good continuity of service.

### Comparison between 10 mA and 30 mA sensitivities

An RCD set to 10 mA will trip somewhat more quickly than an RCD set to 30 mA. But a 10 mA setting significantly increases the risk of disturbing the continuity of service due to nuisance tripping caused by natural leakage currents.

■ **Indirect contact:** contact of a person with exposed conductive parts that are normally not live, but may become live by accident. This situation is due to failure of the insulation for a device or conductor, resulting in an insulation fault.

The electrical risk depends on the touch voltage between the exposed conductive parts of the faulty equipment and earth or other exposed conductive parts located nearby.

The design of protection devices based on the physiological thresholds stipulated in IEC standard 60479 and complying with the rules defined in standard IEC 60364 has made it possible to create safe electrical installations.

# System earthing arrangements

In defining the required protection where dangerous faults are managed by automatically interrupting the supply, the installation standards propose various system earthing arrangements.

For further information, see the Cahiers Techniques documents 172, 173 and 178.

For low-voltage electrical distribution systems, there are three types of system earthing arrangements.

The earth-fault current is:

- dangerous and comparable to a short-circuit: TN system or IT 2<sup>nd</sup> fault with the exposed conductive parts connected to a single earth electrode
- dangerous but limited by the earthing impedances: TT system or IT 2<sup>nd</sup> fault with separate earth electrodes
- not dangerous and very low (in fact limited by the natural leakage impedance): IT system first fault.

Use of an RCD protection device is in fact necessary only when the insulation-fault current is dangerous but low. That is why RCD protection is virtually mandatory in TT systems, but is used in the others only when the other protection systems are not effective.

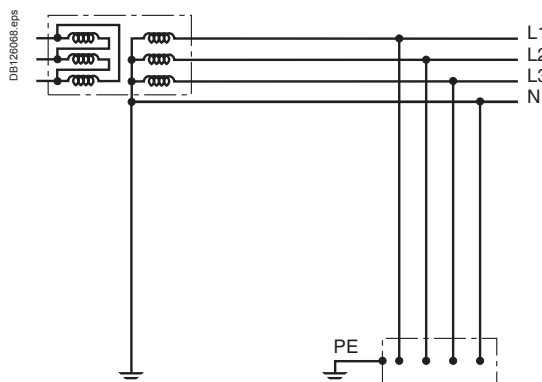

## TT system.

In this system:

- the source neutral is connected to an earth electrode separate from that of the exposed conductive parts
- all the exposed conductive parts protected by a given breaking device must be connected to the same earth electrode.

### Characteristics

- The insulation-fault current is low and limited by the earthing resistances (a few amperes)
- An insulation fault may create a risk of electrocution: the TT system requires immediate breaking of the current
- The SCPD overcurrent protection devices cannot provide protection against insulation faults because the current is too low. An RCD, designed to monitor insulation faults, is required.

### Using RCDs

An RCD must be installed at the head of the installation.

- **RCD threshold settings (see section 531.2.4.2 in standard IEC 60364)**

The mandatory rule in setting the threshold is  $I\Delta n \leq U_L / R$ , where:

- $U_L$  is the rated safety voltage for the electrical installation
- $R$  is the resistance of the earth electrode for the exposed conductive parts downstream of the RCD.

### Maximum resistance of the earth electrode as a function of the rated residual operating current for the RCD

RCD rated residual operating current ( $I\Delta n$ )	Maximum resistance of the earth electrode ( $\Omega$ )
<b>Low sensitivity</b>	
20 A	2.5
10 A	5
5 A	10
3 A	17
<b>Medium sensitivity</b>	
1 A	50
500 mA	100
300 mA	167
100 mA	500
<b>High sensitivity</b>	
$\leq 30$ mA	$> 500$

**Note:** if the earthing resistance is  $> 500 \Omega$ , the RCD is set to 30 mA.

- **RCD time delays**

### Maximum disconnecting time of protection device(s) (according to table 41A extract of standard IEC 60364)

SLT	TT	
Ph-N voltage (V)	AC current	DC current
$50 \text{ V} < U_0 \leq 120 \text{ V}$	0.3 s	5 s
$120 \text{ V} < U_0 \leq 230 \text{ V}$	0.2 s	0.4 s
$230 \text{ V} < U_0 \leq 400 \text{ V}$	0.07 s	0.2 s
$U_0 > 400 \text{ V}$	0.04 s	0.1 s

To ensure discrimination between the RCD protection devices, an operating time not exceeding one second is permitted by standard IEC 60364 for distribution circuits.

# Protection using Vigirex RCDs

## System earthing arrangements

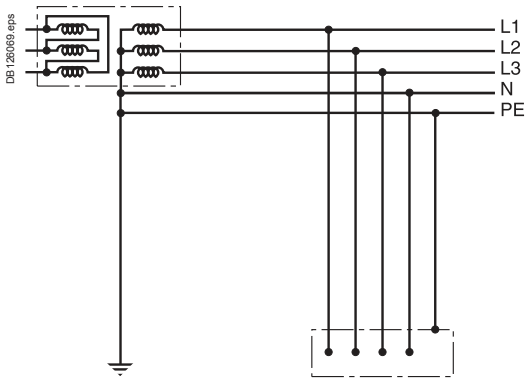

TN-S diagram.

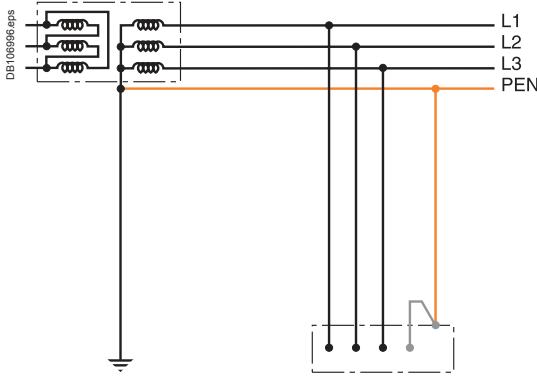

TN-C diagram.

### TN system

In this system:

- the low-voltage neutral point of each source is directly earthed
- all the exposed conductive parts of the installation are connected to earth (and to the neutral) by a protection conductor:
  - PE, separate from the neutral (the TN-S system)
  - PEN, the same as the neutral (the TN-C system).

### Characteristics

- The fault current is high, limited only by the cable impedances (a few amperes)
- An insulation fault may create a risk of electrocution: the TN system requires virtually immediate breaking because an insulation fault is comparable to a single-phase phase-to-neutral short-circuit. SCPD devices may be used to protect against insulation faults if they comply with the operating times imposed by the standard. The mandatory breaking times are indicated in the table below.

### Using RCDs (only for TN-S)

Maximum disconnecting time of protection device(s)  
(according to table 41A of standard IEC 60364)

SLT	TN	
Ph-N voltage (V)	AC current	DC current
$50\text{ V} < U_0 \leq 120\text{ V}$	0.8 s	5 s
$120\text{ V} < U_0 \leq 230\text{ V}$	0.4 s	5 s
$230\text{ V} < U_0 \leq 400\text{ V}$	0.2 s	0.4 s
$U_0 > 400\text{ V}$	0.1 s	0.1 s

If the loop impedance is too high (long cables) or the source short-circuit power is too low (operation on engine generator set power), use of a low-sensitivity RCD may be worthwhile.

### RCD threshold settings

- for long cables, the operating current is provided by the zero-sequence short-circuit current, which may be estimated, by default, as  $I_{\Delta n} \leq 0.8 U_0 / R_{ph} + R_{PE}$

**Note:** there are no setting constraints, even if the loop impedance is high (it rarely exceeds one tenth of an ohm). As a result, it is rarely necessary to set the current under 1000 A. This operating principle for RCDs is similar to that imposed by the NEC, called Ground Fault Protection (see protection against fire hazards, page E-11), because the goal is in fact to control, in the TN-S system, the impedance of the fault loop (see the expert guide no. 2 GFP).

- for operation on engine generator set power, the previous calculation remains valid if the output circuit in question has a low rating compared to that of the engine generator set, otherwise the operating threshold must be set to  $I_{\Delta n} \leq 3 I_N$ .

### RCD time delays

The RCDs must operate within the times stipulated in the table above.

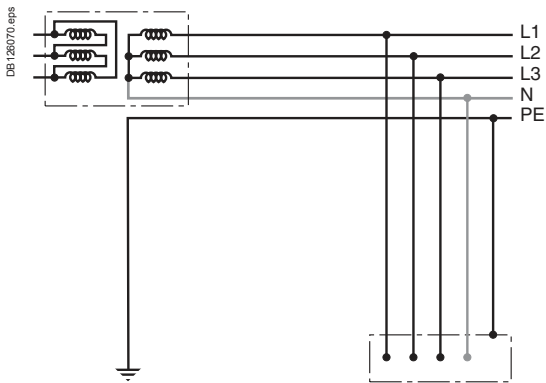

IT system.

## IT system

In this system:

- the transformer neutral is:
  - either unearthed (isolated neutral)
  - or earthed via a high impedance (impedant neutral)
- the exposed conductive parts in the installation are:
  - all interconnected and connected to the same earth electrode
  - interconnected in groups and each group is connected to a given earth electrode.

### Characteristics

- The first insulation fault does not generally require breaking of the circuit. The fault must be detected, indicated and repaired before a second insulation fault occurs on another live conductor, in which case breaking must be immediate
- IT system 2<sup>nd</sup> fault with earth electrodes not interconnected  
The required protection system is identical to that for the TT system with one or more earth electrodes
- IT system 2<sup>nd</sup> fault with earth electrodes interconnected  
The required protection system is identical to that for the TN-S system.

### Using RCDs

- IT system for the 1<sup>st</sup> fault

If medium-sensitivity devices are used, they must be set to at least double the current flowing for a first fault

**Note:** the 1<sup>st</sup> fault current can reach 1 A depending on the size of the distribution system (see Cahier Technique document 178).

# Protection using Vigirex RCDs

## Protection of property: fire hazards

RCDs are an effective means to provide protection against fire hazards because control over the level of leakage current is the only way to manage this risk.

**For the TT, IT and TN-S systems, the risk of electrical fire hazards is eliminated by a 300 mA RCD.**

### Analysis of the risk

- In the 1980s and 1990s, a study carried out by an insurance company in Germany on fires on industrial and commercial premises revealed that:
  - the cost was extremely high, reaching several hundred million euros
  - the cost increased 600 %, i.e. much faster than the increase in the GNP (> 2 times faster over 20 years).

It is necessary to become aware of the dangers of fire hazards not only in terms of safety, but also in terms of cost.

An analysis of the situation showed that electricity was an important factor (the cause of approximately 40 % of fire accidents).

- The analysis showed furthermore that there are two main causes:
  - the 1<sup>st</sup> major cause is the creation of electrical arcs and arc tracking due to humidity. These arcs can develop only with impedant fault loops (> 0.6 Ω) and appear only when insulation faults occur or stray currents flow. Very little energy is required to launch the phenomenon (a few joules), i.e. an insulation-fault current or a stray current ≥ 300 mA represent a real risk of fire.

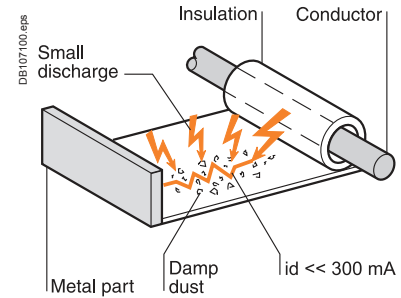
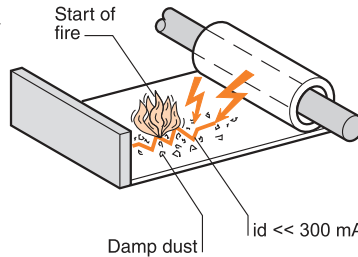
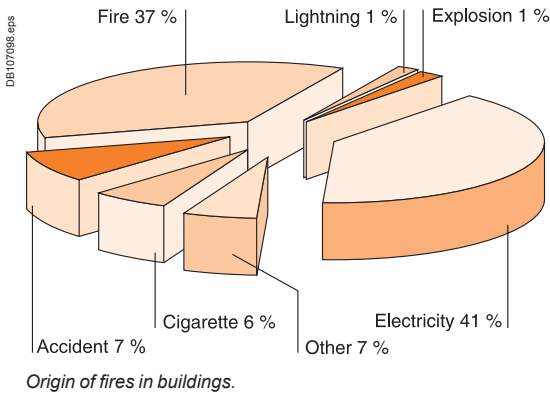

Tests have shown that a very low insulation-fault current (a few mA) can develop and, starting at 300 mA, cause the start of a fire in an environment of damp dust.

- the 2<sup>nd</sup> cause is related to uncontrolled temperature rise caused by incorrectly set protective devices or incorrectly calculated fault-loop impedances (due primarily to age or lack of installation maintenance). Because the thermal-protection devices did not operate correctly, excessive temperature rise due to overcurrents or a short-circuit resulted in a fire.

## Installation standards

■ Installation standard IEC 60364 § 32 defines the various building categories. In particular, section 322.5 characterises buildings according to the types of risks:

- BE2: risk of fire
- BE3: risk of explosion.

It stipulates the special requirements for these building categories as well as:

- in § 482.2.10, the use of RCDs set to 500 mA, (soon to be replaced by 300 mA)
- in § 482.2.13, the interdiction to use the TN-C system.

Generally speaking, it recommends the use of RCDs for all types of low-voltage installations as the means to prevent fire hazards.

■ The National Electrical Code (NEC), the installation standard in the United States, requires use of GFP. According to NEC, the TN-S system cannot manage the impedance of the insulation-fault loop (typically the case for the second cause of a fault causing a fire). The purpose of the GFP device is to break the circuit before the fault can produce a high, destructive current. The threshold may be set from a few hundred amperes up to 1200 A.

**Note:** GFP protection, for thresholds up to 250 A, can be provided by Vigirex RCDs.

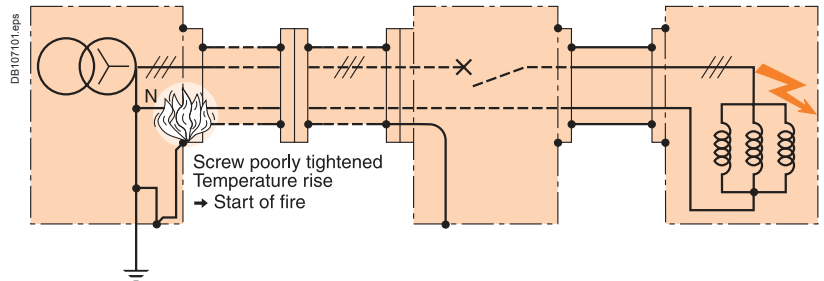

Poorly managed fault loop in a NEC system.

### Earth-leakage current

#### Cable leakage capacitance

The stray capacitance of the cables is the cause of a continuous leakage current, called the “**natural leakage current**”, because a part of the current in the capacitors does not return to the source in the live conductors.

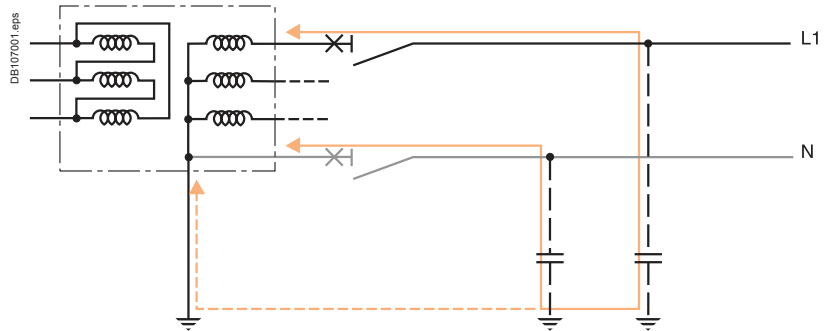

Continuous leakage current due to stray capacitances of conductors (dotted lines).

This leakage current “spreads” throughout the entire installation. The general level of the capacitance between a cable and earth is 150 pF/m. For three-phase equipment, any dissymmetry between the phases reinforces these phenomena.

#### Load leakage capacitance

Non-linear loads, primarily those with static rectifiers, draw low-frequency and high-frequency harmonics. To limit the electromagnetic disturbances and comply with the EM requirements contained in the IEC 61000 standards, these loads are equipped with RFI filters that are directly earthed.

These filters increase the continuous earth-leakage current.

This leakage current is called the “**intentional leakage current**”.

**Note:** this phenomenon is amplified by the presence of low-frequency harmonic voltages which increase the flow of common-mode currents.

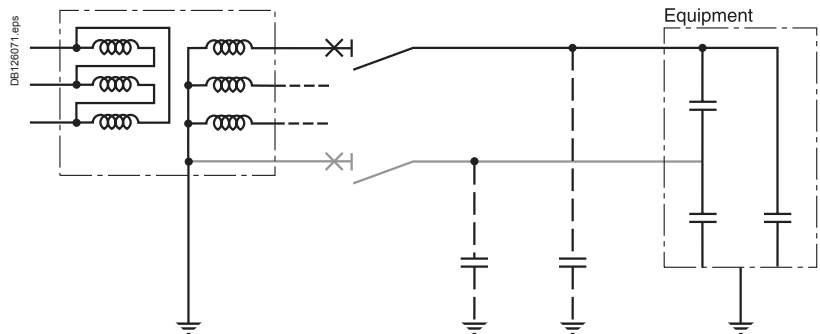

Capacitances between live conductors and earth.

The capacitors installed at the input of electronic equipment have a capacitance of approximately 10 to 100 nF.

**Note:** in the IT system, additional precautions must be taken when installing RFI filters.

#### Leakage capacitance / approximate values

Component	Differential-mode capacitance	Common-mode capacitance
Standard cable (not shielded)	20 pF/m	150 pF/m
Shielded cable	30 pF/m	200 pF/m
Frequency converter	x 100 µF (with rectifier)	10 to 100 nF
PC, printer, cash register	x 10 µF (with rectifier)	10 nF
Fluorescent lighting	1 µF /10 W (compensation capacitor)	1 nF (electronic ballast)

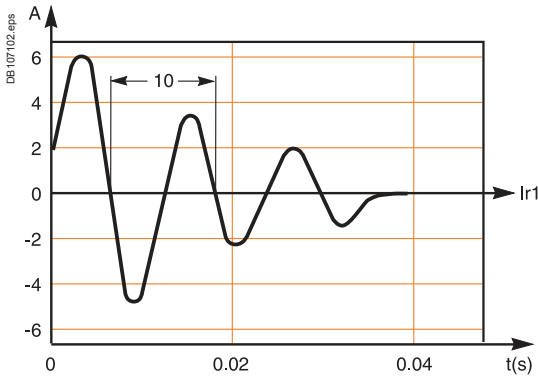

Residual current following operation of a switch.

The environment and the loads of a low-voltage electrical distribution system generate three major types of disturbances that impact on the earth-leakage currents in the system.

■ **Overvoltages**

Lightning, switching overvoltages

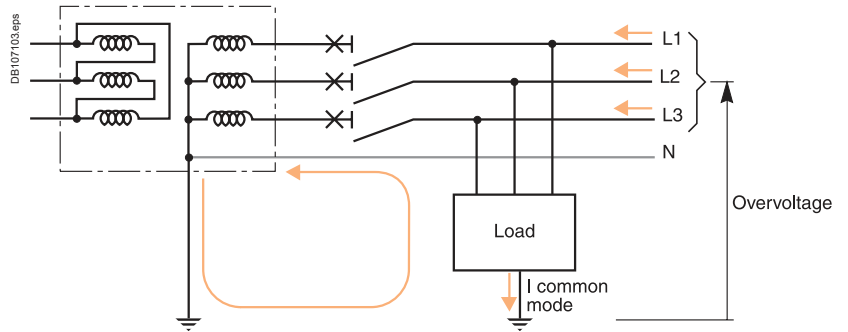

Example of a common-mode disturbance.

**Overvoltages / approximate values**

Type	Amplitude (xUn) or kV	Duration	Frequency or rise time
Insulation fault	≤ 1.7	30 - 1000 ms	50 Hz
Switching	2 - 4	1 - 100 ms	1 - 200 kHz
Lightning	2 to 8 kV <sup>(1)</sup>	1 - 100 μs	1 μs
Electrostatic discharge	8 kV	1-10 μs	25 ns

<sup>(1)</sup> Depending on the position in the installation.

These overvoltages, via the natural leakage capacitance of the system, cause more or less high transient leakage currents.

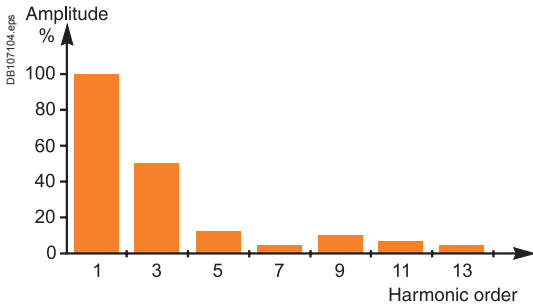

Harmonic spectrum of the current.

■ **Harmonic currents**

These low and high-frequency currents may reach high values (see the harmonic spectrum in the diagram opposite). These harmonic currents must be taken into account when calculating the natural and/or intentional earth-leakage current and setting a threshold for RCDs that does not provoke malfunctions.

■ **Waveform of the fault currents**

In addition to the earth-leakage current problems, fault currents with a DC component may arise if an insulation fault occurs. The RCD must not be “disturbed” or “blinded” by this type of fault.

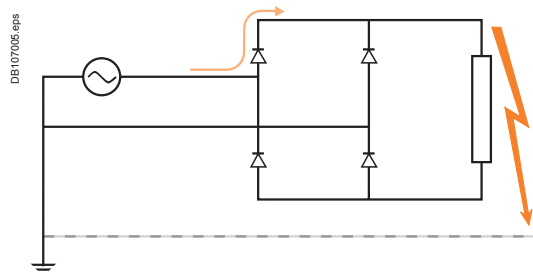
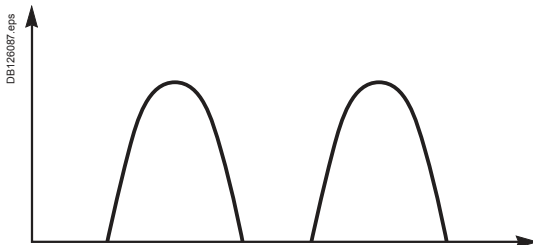

**Consequences for use of RCDs**

These phenomena create considerable earth-leakage currents (transient or continuous).

**The RCD must not react to these leakage currents when they are not dangerous.**

It is necessary to adjust the protection setting for people for indirect contacts, taking into account the prospective leakage current.

# Vigirex devices

## RCD operating principle

Vigirex devices are primarily intended to protect life and property on industrial, commercial or similar sites.

Vigirex RCDs implement:

- an electronic relay supplied by an auxiliary source
- measurements using a separate toroid.

When there is no insulation fault, the vector sum of the currents flowing in the live conductors is equal to zero.

If an insulation fault occurs, the sum is no longer equal to zero and the fault current creates in the toroid a magnetic field which generates a current on the secondary winding.

This current is monitored by a measurement circuit and, if it overruns the set threshold for a time greater than the set intentional time delay, the relay orders the current-breaking device to open.

Vigirex devices comply with standard IEC 60755 (the general standard governing RCDs) and with standard IEC 60947-2 annex M.

These standards define the various device characteristics and the necessary tests for the products.

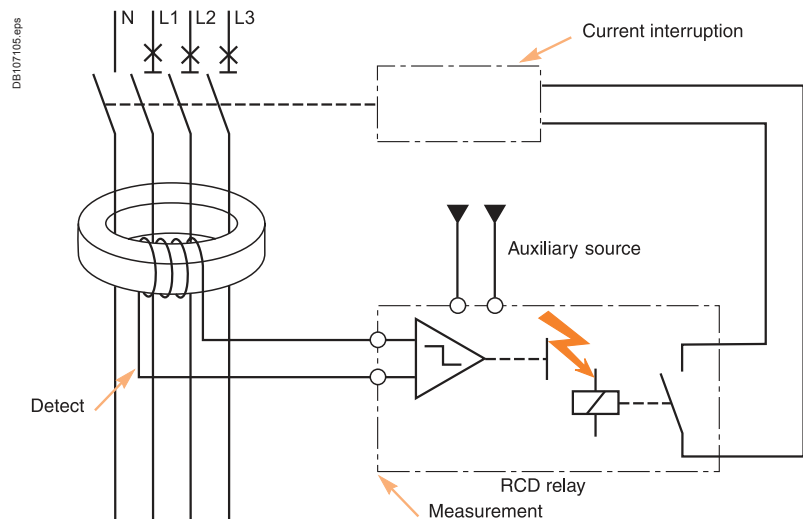

RCD operating principle.

### RCD sensitivity levels

Electronic relays offer wide setting ranges for the sensitivity and the time delay. The installation standards characterise the required RCD sensitivity depending on the need for protection.

#### Sensitivity depending on the different needs

High sensitivity	Medium sensitivity	Low sensitivity
30 mA	100 mA to 3 A	> 10 A

### RCD operating / non-operating current

The standards indicate the preferred values for the residual operating current settings.

Operating current  $I_{\Delta n}$  in A:

0.006 – 0.01 – 0.03 – 0.1 – 0.3 – 0.5 – 1 – 3 – 10 – 30.

To take into account the tolerances (temperature, dispersion of components, etc.), the standards indicate that an RCD device set to an  $I_{\Delta n}$  value must:

- **not operate** for all fault currents  $\leq I_{\Delta n}/2$
- **operate** for all fault currents  $\geq I_{\Delta n}$ .

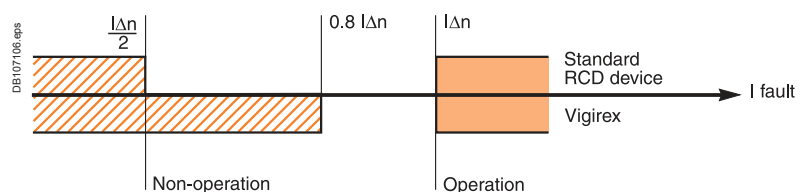

The technologies employed for Vigirex devices guarantee dependable non-operation up to  $0.8 I_{\Delta n}$ .

Standard IEC 60947-2 annex M allows manufacturers to indicate the level of non-operation if it differs from the general rule.

---

### Measurement of residual currents

The main difficulties for industrial RCDs lie in ensuring high-quality measurements.

■ The measurement of fault currents in the presence of linear loads is not difficult:

□ the frequency of the fault current is 50/60 Hz

□ leakage currents are generally low

■ However, the measurement of fault currents in the presence of non-linear loads requires RCDs capable of:

□ discriminating between the fault current and leakage currents

□ not being “blinded” by the DC components.

### Toroid characteristics

The toroids used for Vigirex devices enable the electronic relay to measure the different zero-sequence currents flowing in the monitored circuit.

They are designed to:

- measure currents
- withstand overvoltages
- withstand short-circuit currents.

### Measurement of zero-sequence currents

#### ■ Measurement dynamics

The necessary measurement dynamics require a special magnetic circuit to measure very low currents and correct adaptation of the impedance (to avoid saturation) when measuring higher currents.

To that end, the correct compromise is required between:

- a material with high magnetic permeability  $\mu_r$  and the saturation phenomena
- toroid size (cross-sectional area) and acceptable dimensions
- a high number ( $n$ ) of turns and:
  - sufficiently low resistance
  - sufficient signal amplitude (gain  $1/n$ ).

#### ■ Measurement limits

When a three-phase current flows through the measurement toroid and there is no insulation fault (the sum of the currents is equal to zero), a secondary current equivalent to a false zero-sequence fault current is created. This is due to leakage flows caused by manufacturing tolerances. It is necessary to qualify this phenomenon by indicating the rated operational current for a given zero-sequence leakage current.

#### Table indicating the limits for $I_{\Delta n}$ / rated current

See page B-9.

**Note:** strict compliance with the installation rules for the cables passing through the toroid is indispensable.

The addition of a "regulator sleeve" for the magnetic field considerably increases the rated operational current.

### Measurement of disturbed currents

Waveform capture of currents comprising low-frequency harmonics is not a problem for the toroids.

The main difficulty is to measure current with a DC component, which can saturate the magnetic circuit and reduce the sensitivity of measurements. In this case, there is the risk that a dangerous fault current might not be detected. To avoid this problem and ensure that the toroid provides an accurate output signal, it is necessary to use a magnetic material that does not have a horizontal saturation curve, with low residual induction  $B_r$ .

This is the means to ensure type A measurements.

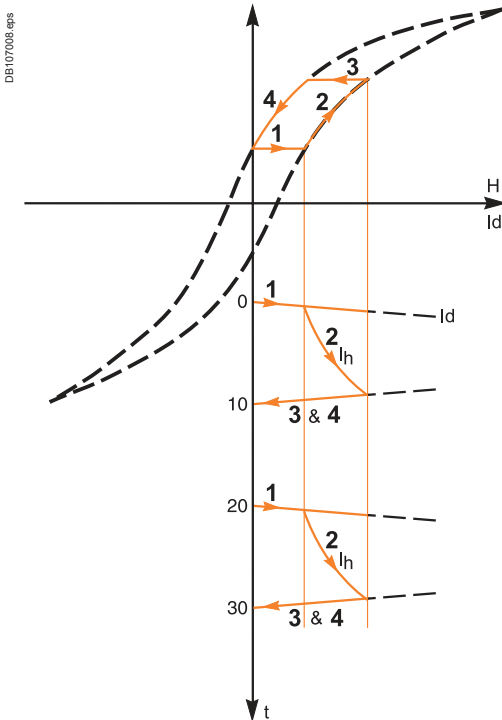

Toroid hysteresis cycle for type A measurements.

$I_d$ : primary current  
 $I_m = I_d - I_h$

## Short-circuit withstand capacity

The RCD must be sized for the short-circuit currents corresponding to the controlled protection device, at the point in the installation where it is placed.

Standard IEC 60947-2 annex M requests that the various short-circuit currents that the RCD must support be declared to ensure correct operation without damage to the interconnected devices.

- I<sub>sc</sub>: rated short-circuit current
- I<sub>cw</sub>: rated short-time withstand current
- I<sub>Δw</sub>: rated conditional residual short-circuit withstand current.

**Note:** the requested characteristics are required for an RCD-circuit breaker combination. For an RCD-switch combination, more in-depth study is required if the fault current that must be interrupted is greater than 6 I<sub>n</sub> (where I<sub>n</sub> is the switch rating).

For the Vigirex range, Schneider guarantees practical values, consistent with the characteristics of the monitored circuits and the protection circuit breakers.

	Vigirex with TA 30, PA 50, IA 80, MA120 toroids combined with a Schneider Electric brand circuit breaker, rated ≤ 630 A	Vigirex with SA 200 and GA 300 toroids combined with a Compact NS630b to 3200 A or a Masterpact NT or NW circuit breaker up to 6300 A
I <sub>cw</sub>	100 kA/0.5 s	100 kA/0.5 s
I <sub>sc</sub>	150 kA	100 kA
I <sub>Δw</sub>	85 kA/0.5 s	85 kA/0.5 s

In light of the above, the combination of a Vigirex device with a Compact NS or Masterpact circuit breaker ensures perfect operation and is guaranteed whatever the system earthing arrangement (particularly for TN-S).

## Overvoltage withstand capacity

The overvoltage withstand capacity of Vigirex devices is tested to comply with the requirements in standard IEC 60947-1 appendix H (which reuses those in standard IEC 60664-1 on insulation coordination).

- Impulse withstand voltage

The distribution-system voltage and the position of the device in the system determine the overvoltage levels to which the electrical devices may be subjected (see table H1 in standard IEC 60947-1).

A Vigirex device (relay + toroid) may be installed at the head of an installation.

Schneider Electric consequently guarantees the overvoltage withstand capacity of the toroids for the maximum levels in a low-voltage distribution system up to the maximum permissible rated voltage (1000 V).

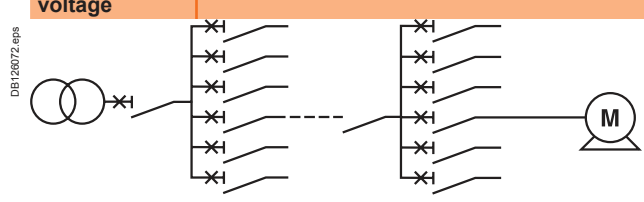
Rated installation voltage	Position		
	Head of the LV installation	On the distribution circuits	Near the loads
	230/400 V	6 kV	4 kV
400/690 V	8 kV	6 kV	4 kV
.../1000 V	12 kV	8 kV	6 kV
Category	4	3	2

- Vigirex implementation

The characteristics listed below are specified.

	Sensors	Supply (for U <sub>s</sub> > 48 V)	Relay output contacts
Reference voltage	1000 V	525 V	400 V
Category	4	4	4
U <sub>imp</sub>	12 kV	8 kV	6 kV

### Characteristics of measurement relays: immunity to natural leakage currents

Vigirex relays implement four techniques:

- to manage the leakage-current measurements without causing nuisance tripping
- and ensure the protection of persons by tripping immediately if a dangerous fault occurs.

### Filtering of harmonic frequencies

- Non-dangerous leakage currents
- frequency converters cause the most specific leakage currents to analyse. The voltage waveform generated by the frequency converter and in particular the voltage fronts caused by IGBT switching result in the flow of high-frequency leakage currents in the supply cables.

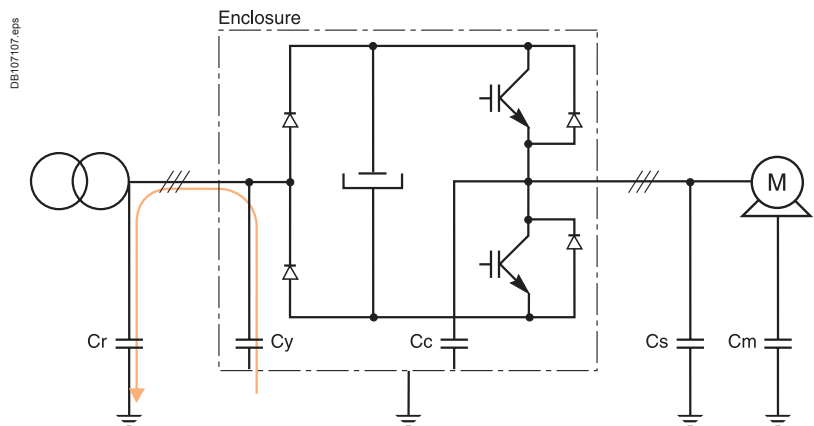

Flow of leakage currents in a frequency converter.

These currents may reach levels of several tens or hundreds of milliamperes (rms value).

### ■ Dangerous faults

Standard IEC 60479 indicates the sensitivity of the human body depending on the frequency. Consequently, the table in question shows that:

- protection for people at the power frequencies 50/60 Hz is the most critical case
- the use of filters corresponding to the "desensitisation curve" ensures perfect safety.

The figure below shows the result of the filters on Vigirex in reducing the effects of the harmonic currents and malfunctions due to transient currents.

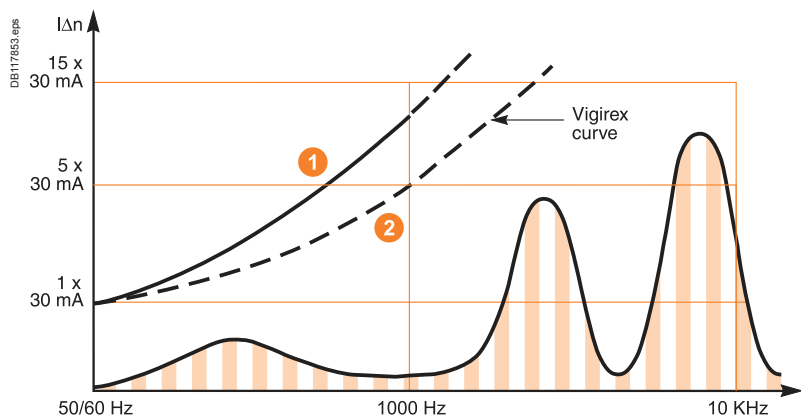

- 1 Frequency factor for the fibrillation threshold (IEC 60749-2).
- 2 Limiting values of the natural leakage currents downstream of a rectifier.

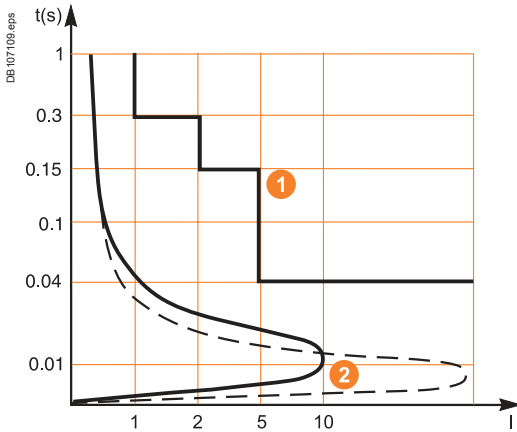

- 1 Standardised RCD response curve as per the table.
- 2 Leakage-current curve for switching in of a load with leakage capacitance.

### Rms measurements

Vigirex devices carry out rms measurements on the zero-sequence currents. This is the means to:

- accurately measure the harmonic currents and avoid nuisance tripping due to non-dangerous currents with high crest factors
- correctly calibrate the energies of the fault currents because, for both fire hazards and the protection of property, it is the energy of the fault current that must be taken into account.

### Curve $I\Delta n$ / non-delayed relay times

Protection for people requires the use of non-delay type relays. These relays must comply with standards to ensure safety.

Standards IEC 60947-2 annex M and IEC 60755 indicate the preferred values for the operating-current setting.

They stipulate the maximum break time depending on the residual fault current. See table B in B.4.2.4.1 in standard IEC 60947-2 annex M.

$I_f =$	$I\Delta n$	$2 I\Delta n$	$5 I\Delta n$	$10 I\Delta n$
Time $T_{ps}$	0.3 s	0.15 s	0.04 s	0.04 s

**Key:**

*Time  $T_{ps}$ : total time required to break the current (including the time for the associated protection device to open)*

*$I_f$ : leakage current*

*$I\Delta n$ : residual operating current setting*

For devices set to 30 mA,  $5 I\Delta n$  can be replaced by 0.25 A, in which case  $10 I\Delta n$  is replaced by 0.5 A.

**Vigirex** uses this type of response curve to manage the false fault currents caused by switching in of loads (transformers, motors).

**Schneider Electric guarantees all the above break times for a Vigirex combined with its circuit breakers rated up to  $\leq 630$  A, particularly when set to 30 mA.**

### Guaranteed non-operation up to $0.8 I\Delta n$

This function equipping Vigirex relays significantly increases (from  $0.5 I\Delta n$  to  $0.8 I\Delta n$ ) the immunity of relays to continuous leakage currents, both natural and intentional.

### Characteristics of measurement relays: measurement of disturbed currents containing DC components

If an insulation fault occurs downstream of a rectifier, a current containing a DC component is created.

The protection devices must remain operational in spite of the DC component.

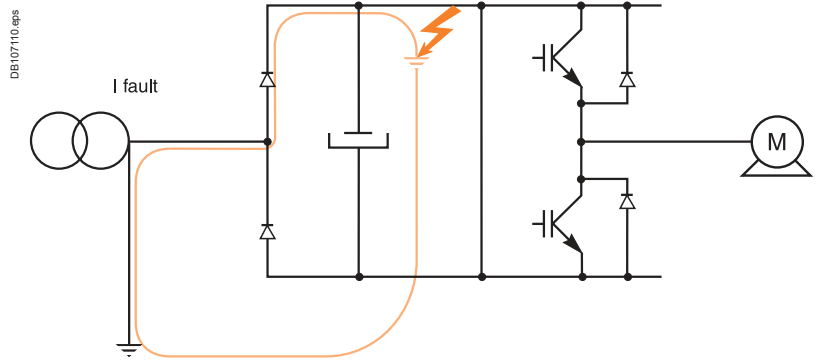

Fault on the DC bus of a converter.

### Classification depending on the residual current to be monitored

The standards define three classifications of residual-current protection depending on the current that must be analysed:

- **AC type:** for sinusoidal AC current.
- **A type:** for AC current with a DC component. These devices are suitable for the detection of rectified single-phase currents.
- **B type:** for DC current. These devices are suitable for all types of current and are required, in particular, for rectified three-phase currents.

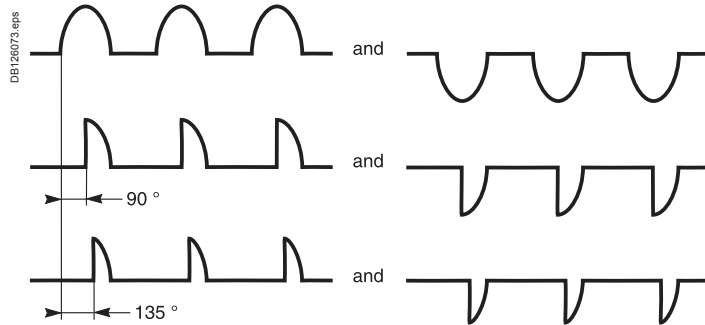

Waveforms of the test currents for A-type RCDs.

## Selection of industrial RCDs

Schneider Electric has carried out large numbers of tests to characterise user needs. A complete analysis of the phenomena involved is available in Cahier Technique document 204.

The table below (copied from chapter 6 of CT document 204) sums up the information: it indicates the type of RCD to be used depending on the system earthing arrangement, the equipment to be monitored and the type of protection required.

Summary table

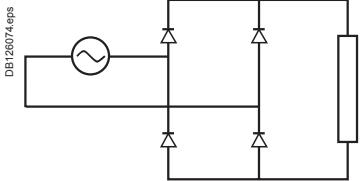
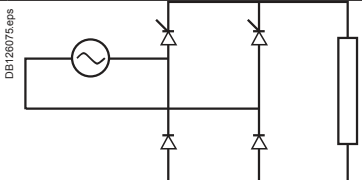
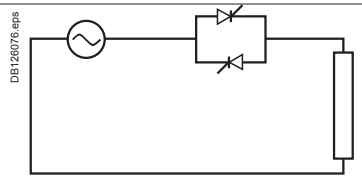
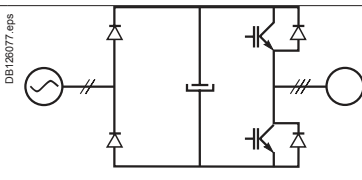
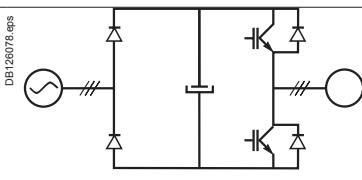
Type of circuit	Application	Diagram	Suitable type of RCD
Diode-based single-phase rectifier	- frequency converters, variable-speed drives - supplies for DC circuits		A
SCR-based single-phase rectifier	- variable-speed drives - battery chargers		A
Regulation devices	- light dimmer - heating regulator		AC
AC/AC converter with single-phase supply	- variable-speed drives		A
AC/AC converter with three-phase supply	- variable-speed drives - welding machines		B A (if no risk of fault on the DC bus)

Protection	Against indirect contact		Against direct contact	
	Three-phase	Single-phase	Three-phase	Single-phase
Supply				
Equipment and installation characteristics	No double insulation of DC bus	With double insulation of DC bus	If further protection is required, if other protection systems against contact fail or if users are careless (see the installation standards).	
SLT: TT or IT with exposed conductive parts not interconnected	B type, low sensitivity ( $\geq 300$ mA)	A type, low sensitivity ( $\geq 300$ mA)	A type, low sensitivity ( $\geq 300$ mA)	A type (30 mA) or B type (30 mA) if the braking resistance is accessible
SLT: TN-S	A type, low sensitivity ( $\geq 300$ mA) <sup>(1)</sup>			
SLT: IT			A type 30 mA	

<sup>(1)</sup> The insulation fault is equivalent to a short-circuit. Tripping should normally be ensured by the short-circuit protection, but use of an RCD is recommended if there is any risk the overcurrent protection will not operate.

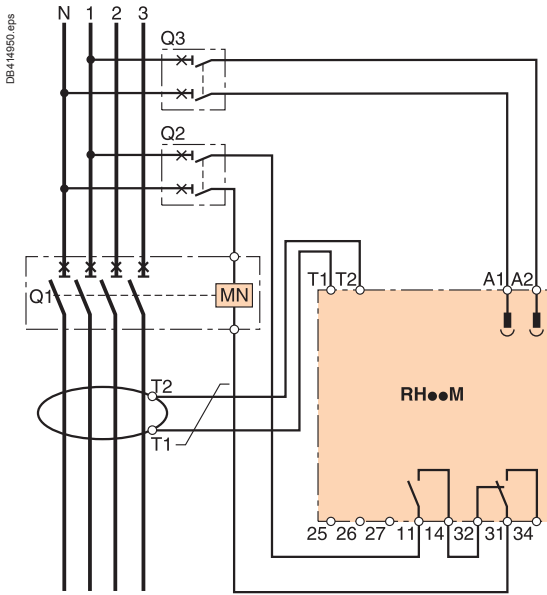

### Characteristics of the relay / toroid combination: measurement integrity

The integrity of measurements depends on the capacity of the RCD to handle the various disturbances on the distribution system. The generic standard for EMC is IEC 61000-6-2 which defines the minimum immunity level.

The test standards in the IEC 61000 series define the various requirement levels. Standard IEC 60947-2 annex M determines the required level for RCDs with separate toroids.

Schneider has established for the Vigirex RCDs its own requirements that are similar or more demanding than those in the standard.

The table below lists the required tests.

Vigirex wired for optimum safety.

Description of phenomena	Test standard		Standardised tests as per IEC 60947-2 annex M	Vigirex tests
	Title	Code		
Discharges, due to the accumulation of static electricity, can lead to malfunctions and destruction.	Electrostatic-discharge immunity test	IEC 61000-4-2	8 kV contact 8 kV in air	8 kV contact <b>15 kV in air</b>
Radiated EM fields (radio-telephones, transmitters) can disturb operation of devices.	Radiated (radio-frequency) EM field immunity test	IEC 61000-4-3	10 V /m 80 to 1000 MHz modulated at 1 kHz	<b>12 V /m</b> 80 to 1000 MHz modulated at 1 kHz
Switching of LV devices (contactors, contact bouncing, breaking of inductive loads, etc.) may cause malfunctions and destruction.	Electrical fast transients/bursts immunity test	IEC 61000-4-4	4 kV on supply 2 kV on I/O 5 kHz fast burst/transient lasting 15 ms every 300 ms	4 kV on supply 2 kV on I/O 5 kHz fast burst/transient lasting 15 ms every 300 ms
Atmospheric overvoltages, switching of MV devices may cause malfunctions and destruction.	Surge immunity test	IEC 61000-4-5	- On supply > 100 V AC 4 kV between line and earth 4 kV between lines - On supply < 100 V AC 2 kV between line and earth 1 kV between lines - On DC supply 0.5 kV between line and earth 0.5 kV between lines - On input/output (I/O) 2 kV between line and earth 1 kV between lines 1.2/50 µs wave, open circuit 8 / 20 µs short-circuit	- On supply > 100 V AC 4 kV between line and earth 4 kV between lines - On supply < 100 V AC <sup>(1)</sup> <b>4 kV between line and earth</b> <b>4 kV between lines</b> - On DC supply <b>2 kV between line and earth</b> <b>1 kV between lines</b> - On input/output (I/O) 2 kV between line and earth 1 kV between lines 1.2/50 µs wave, open circuit 8 / 20 µs short-circuit
EM fields (radio-telephones, transmitters) can cause HF currents resulting in device malfunctions.	Immunity test for conducted disturbances induced by radio-frequency fields	IEC 61000-4-6	10 V 150 kHz to 80 MHz modulated at 1 kHz	10 V 150 kHz to 80 MHz modulated at 1 kHz
Faults on the distribution system may cause malfunctions.	Voltage-dip immunity test	IEC 61000-4-11	Specific RCD-device tests	-

(1) V AC < 48 V, the Vigirex does not have a supply transformer.

---

### **Voltage-dip withstand capacity**

Standard IEC 60947-2 annex M defines precise criteria for the voltage-dip withstand capacity of RCDs that depend on the supply voltage. To guarantee safety, even if the auxiliary source fails, the RCD must operate correctly to 70 % of the rated auxiliary-source voltage.

Vigirex devices comply with the standard.

■ Operation under downgraded voltage conditions (see the characteristics on pages A-26 to A-35). Additional standard functions are built in to make the protection as dependable as possible:

- failsafe operation is possible, see relay wiring
- a voltage LED provides a local indication that voltage is not present.

## Continuity of service: RCD device discrimination

Discrimination is ensured between the RCDs by using time-delay type RCDs.

### Standardised characteristics of time-delay type RCDs

The standards governing RCDs define two categories for time-delay type RCDs.

#### ■ RCD with a time delay $\leq 0.06$ s

These devices generally have a single, non-adjustable time delay. They are intended to ensure discrimination with non-time-delay type RCDs. The standards impose the following characteristics:

##### □ non-operating time

Time delay set for  $2 I_{\Delta n}$ ; must not exceed 0.06 s

##### □ operating time (relay alone)

Must be indicated by the manufacturer

##### □ total time (relay plus breaking device)

The manufacturer must indicate the associated device and guarantee maximum total times not exceeding those in the table below.

$I_f =$	$I_{\Delta n}$	$2 I_{\Delta n}$	$5 I_{\Delta n}$	$10 I_{\Delta n}$
Time Tps	0.5 s	0.2 s	0.15 s	0.15 s

#### Key:

Time Tps: total time required to break the current

$I_f$ : leakage current

$I_{\Delta n}$ : residual operating current setting.

**Note:** if the threshold is set to  $< 30$  mA, the relay must operate immediately.

When set to I, Vigirex relays comply with the requirements for these time-delay type RCDs.

#### ■ RCD with time delay $> 0.06$ s

These are primarily industrial time-delay type RCDs used to ensure several levels of discrimination.

##### □ preferred non-operating times (in s)

The standard proposes the following time delays:

0.1 – 0.2 – 0.3 – 0.4 – 0.5 – 1.

The operating time must be indicated on the relay and guaranteed by the manufacturer.

##### □ operating time (relay alone)

Must be indicated and guaranteed by the manufacturer

##### □ total time (relay plus breaking device)

This time may be indicated by the manufacturer.

## Vigirex RCDs

Vigirex RCDs offer a wide range of time delays and comply with the tests imposed by standard IEC 60947-2 annex M.

■ **Minimum non-operating time:** indicated by the position of the delay setting dial on the front of the relay, as shown in the diagram opposite.

■ **Operating time / total time:** indicated in the tables for device characteristics. For setting I (0.06 s) and the other time-delay settings, Schneider Electric guarantees the total times for Vigirex relays combined with Schneider Electric-brand breaking devices (switches, circuit breakers).

## Implementing discrimination

Discrimination between upstream and downstream RCDs is necessarily of the **current and time type**.

It is ensured by correctly adjusting:

- the operating-current settings
- the total times.

The following general discrimination rules ensure correct operation:

■ in terms of the current, the setting for the upstream device must be **double** that of the downstream device (in accordance with the standardised rules for the operating / non-operating currents)

■ in terms of the time, the non-operating time (time delay) for the upstream device must be greater than the total time (the intentional RCD-device delay and the breaking time of the breaking device) for the downstream device.

These two conditions are summed up here:

upstream  $I_{\Delta n} \geq 2 \times$  downstream  $I_{\Delta n}$

upstream non-operating time  $\Delta t \geq$  downstream total time  $\Delta t$ .

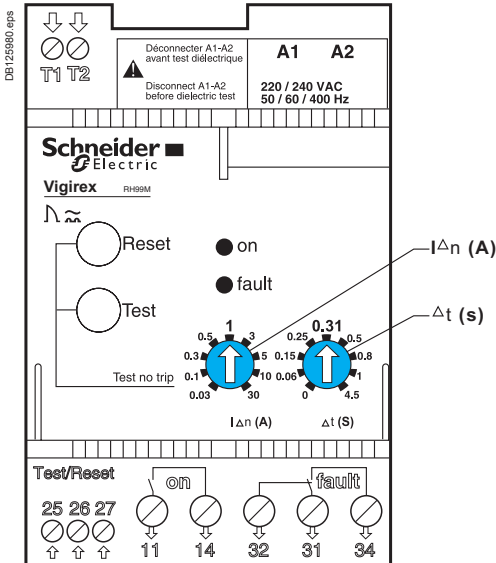

$I_{\Delta n}$  (A): residual operating-current setting (the relay operates for a fault current  $\geq I_{\Delta n}$ ).  
Schneider Electric guarantees non-operation for all fault currents  $< 0.8 I_{\Delta n}$ .  
 $\Delta t$  (s): minimum non-operating time.

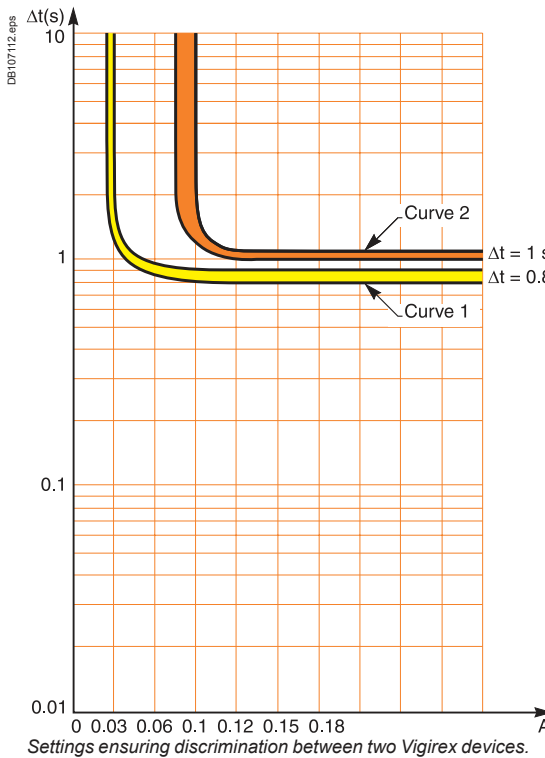

For this reason, it is advised to use RCDs complying with the preferred standardised values.

**Note:** an RCD does not limit the fault current and for this reason, current discrimination **alone** is not sufficient.

The time/current curves indicate the operating-current values of the Vigirex devices depending on their standardised characteristics. When superposed, the curves indicate the protection settings required to ensure total discrimination (see the curves on pages E-43 to E-46).

The Vigirex devices, combined with Schneider Electric breaking devices (switches, circuit breakers), have successive operating-current and time-delay settings that enhance the discrimination rules mentioned above.

#### Vigirex discrimination rules

System (Schneider Electric breaking device + RCD)		Setting	
Upstream	Downstream	Ratio $I\Delta n$	Time delay
Vigirex	Schneider RCD	1.5	1 setting apart, except <sup>(1)</sup>
Schneider RCD device	Vigirex	2	1 setting apart, except <sup>(1)</sup>

<sup>(1)</sup> A difference of two settings is required for the 0.25 s setting (i.e. the 0.5 s and the 0.25 s settings).

**Schneider Electric guarantees the coordination of a Vigirex RCD / Compact NSX circuit-breaker combination with all other RCDs as long as the general setting rules or those specific to Vigirex relays are observed.**

#### Example of settings for discrimination:

A Vigirex RHU relay set to  $I\Delta n = 0.1 \text{ A} / \Delta t = 1 \text{ s}$  (tripping curve 2) combined with a Compact NSX630 ensures total discrimination with a Vigirex RH99 set to  $I\Delta n = 0.03 \text{ A} / \Delta t = 0.8 \text{ s}$  (tripping curve 1) combined with a Compact NSX250.

### Summary of RCD settings depending on the system earthing arrangement

RCD tripping/immunity depending on the load and the system earthing arrangement

System earthing arrangement	TT	TN-S	TN-C	IT (1 <sup>st</sup> fault)	IT (2 <sup>nd</sup> fault)
I fault	Low	High	High	Very low	-
Typical value	A few Amps	A few kA	A few kA	Less than 1 A	-
Protection of persons	RCD	Circuit breaker	Circuit breaker	1 <sup>st</sup> fault not necessary	IT becomes TT or TN
Additional protection of persons	-	RCD	-	-	Idem TN
Threshold	$\leq UL/R$	3 to 250 A	-	If RCD > 2 x first-fault leakage current	Idem TT or TN
Time delay	< 1 s <sup>(1)</sup>	< 0.4 s as per U0	-	-	Idem TT or TN
Protection against fire hazards	RCD	RCD	-	RCD	RCD
Threshold	300 mA	300 mA	-	300 mA	300 mA
Time delay	-	-	-	-	-

<sup>(1)</sup> See table page E-5.

## Special protection

Vigirex devices may be easily adapted to special protection applications given:

- the wide range of operating-current and time-delay settings
- the measurement toroids are separate
- the device is not part of the circuit-breaking function.

## Additional information on RCD protection of persons

### TT system with multiple earth electrodes

An RCD must be installed at the head of each part of the distribution system where the exposed conductive parts of the loads are connected to a separate earth electrode. This is because dangerous currents may flow without tripping the RCD at the head of the installation.

### Setting of RCD at the head (where applicable)

Installation of an RCD at the head is mandatory if the insulation of the upstream part of the installation is not rated class 2.

A fault downstream of the RCD at the head must be taken into account under the worst-case conditions. The value that must be taken into account is the maximum value of the earth electrodes ( $R_{max}$ ).

The mandatory rule is  $I\Delta n \leq U_L / R_{u\ max}$ .

The downstream RCDs at the head of each group of loads must be set depending on the earthing resistance of each group of loads. The setting must also take into account discrimination with the upstream RCD(s).

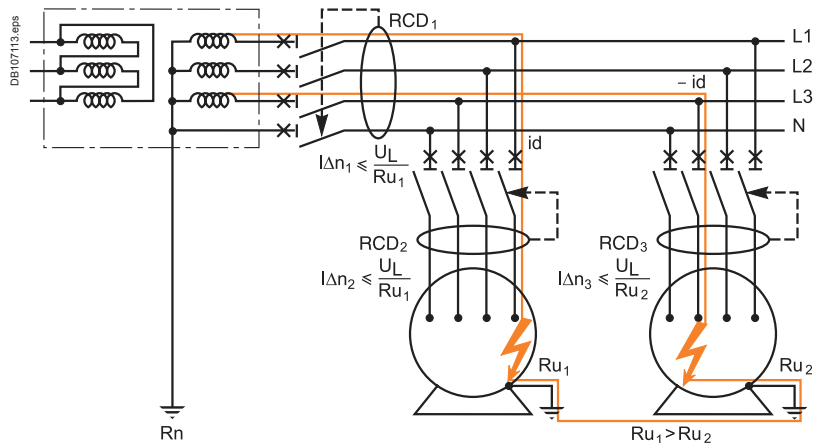

Multiple earth electrodes and flow of current.

### IT system 2<sup>nd</sup> fault, neutral protection

For protection of the neutral conductor, an RCD can replace a trip unit for the neutral pole (4P circuit breaker with 3P tripping) if the RCD  $I\Delta n$  setting is less than or equal to 0.15 x the permissible current in the neutral conductor (see IEC 60364 - 474.3.2.2). The RCD interrupts all the live conductors, including the neutral.

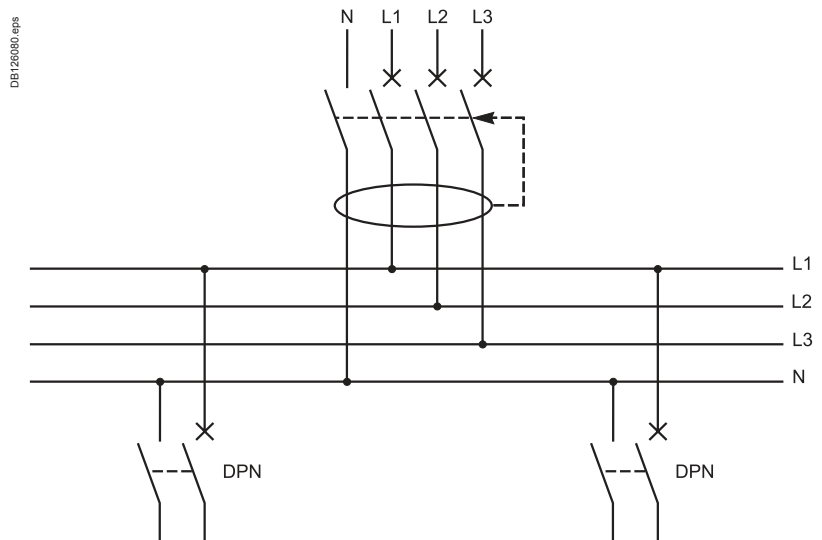

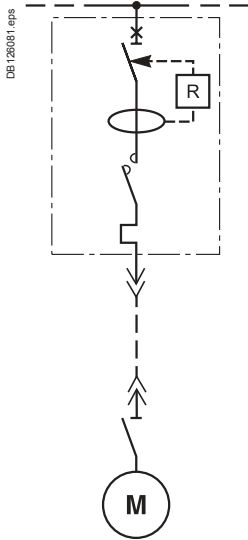

## Protection of property

### Protection of loads

A minor insulation fault can rapidly develop and turn into a short-circuit causing major damage and even the destruction of the load. A medium-sensitivity RCD (a few amperes) provides suitable protection by shutting down the load before major damage can occur.

#### ■ RCD threshold settings

From 3 to 30 A depending on the type of load

#### ■ RCD time delays

1 second is a typical value.

### Motor applications

Use of a Vigirex relay on a motor feeder avoids major damage if an insulation fault occurs (rewinding of stators, insulation breakdown, etc.). The modular product design makes for easy installation in drawers.

### Protection of parallel-connected generators

An insulation fault inside the metal casing of an engine generator set risks severely damaging the generator. The fault must be rapidly detected and cleared. What is more, if other generators are connected in parallel, they will supply the fault and may provoke tripping due to an overload. Continuity of service is no longer ensured.

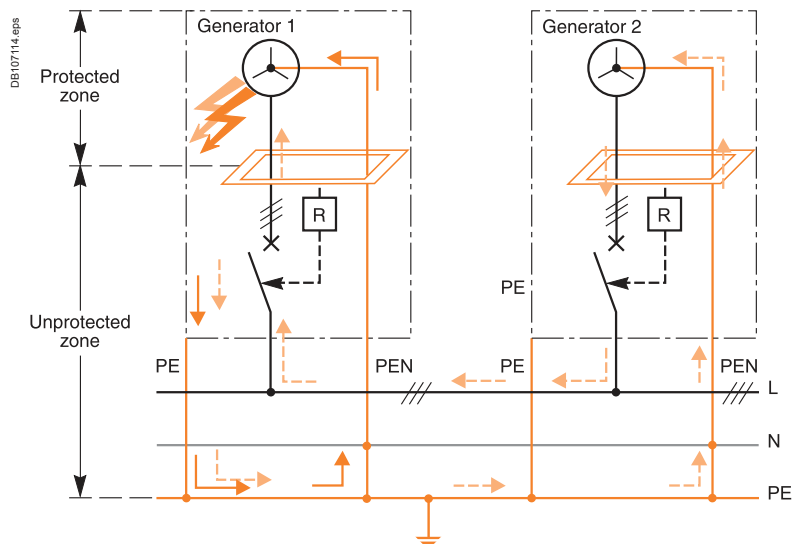

An RCD installed on the generator circuit is the means to:

- rapidly disconnect the faulty generator and maintain continuity of service
- intervene on the control circuits of the faulty generator to shut it down and reduce the risk of damage.

The RCD must be installed as close as possible to the protection device for each engine generator set (see the diagram). The diagram is of the TN-S type for the generator set considered as a load and of the TN-C type for the generator sets considered as generators.

#### ■ If a fault occurs on generator 1:

- a zero-sequence fault current flows in PE1  $I_{d1} + I_{d2}$  because sources 1 and 2 supply the fault.
- this current is detected by RCD1 which immediately disconnects generator 1 (circuit breaker CB1 opens).
- This current is not detected by RCD2 because of the TN-C system.

### RCD threshold settings

From 3 to 100 A depending on the rating of the engine generator set.

### RCD time delays

Instantaneous or short time delay (< 100 ms).

## Example of protection using RCDs

The diagram below shows a low-voltage distribution system (TT system) in a one-story building containing a number of workshops. The measured resistance of the earth electrodes is  $1\ \Omega$  for the transformer,  $1\ \Omega$  for the engine-generator set,  $5\ \Omega$  for workshop A and  $10\ \Omega$  for workshop B.

Workshop B has machines with high intentional leakage currents (filters, etc.). The limiting touch voltage is  $50\ \text{V}$ , corresponding to a normal environment.

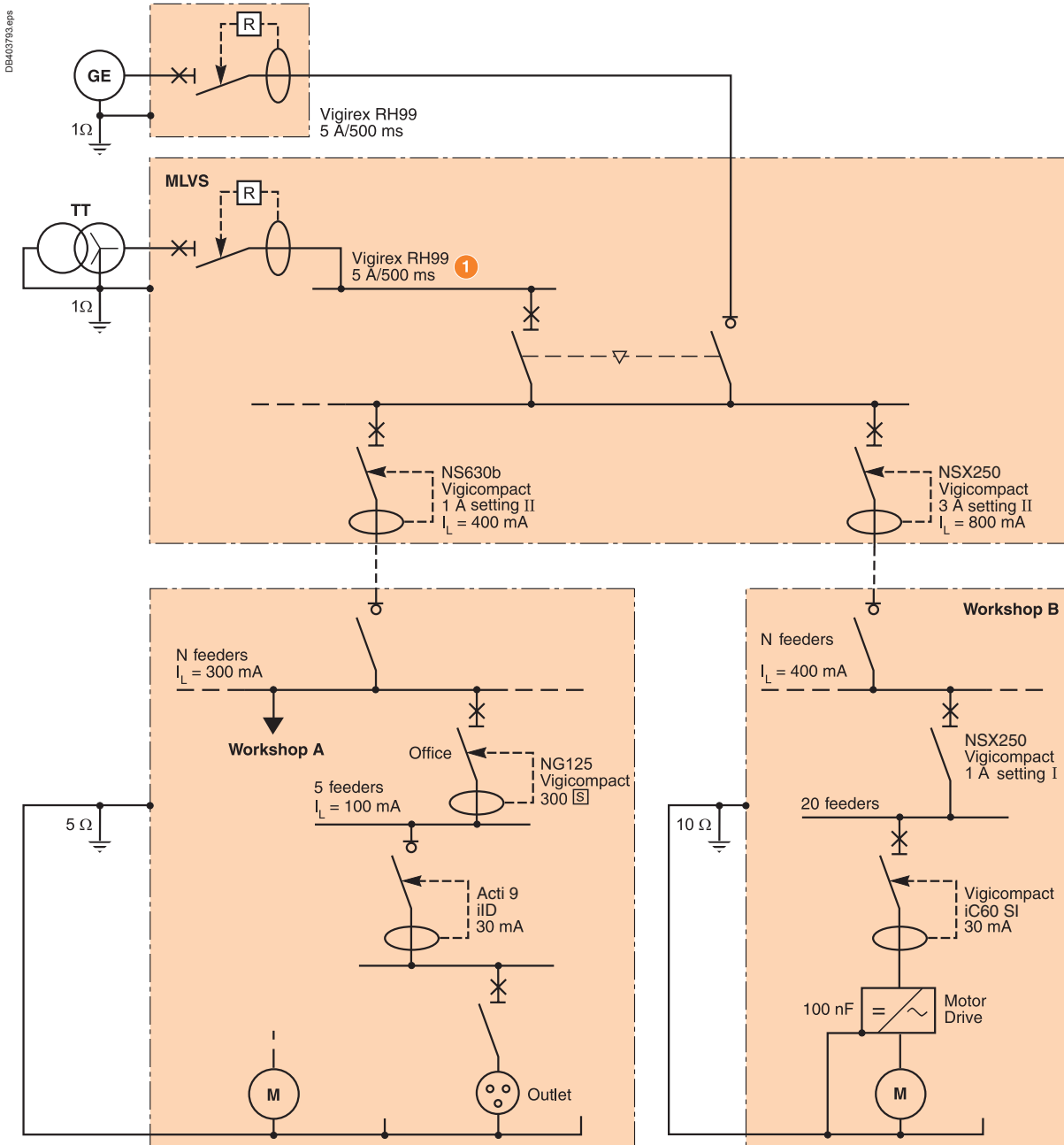

Distribution diagram with discrimination.

The RCD settings as shown in the diagram:

- provide for the safety of life and property
- ensure total discrimination in the event of an insulation fault in the installation
- eliminate any problems concerning malfunctions due to natural leakage current.

## Requirements of standards

### Protection against indirect contact

An RCD (indicated ① in the diagram on page E-28) must be installed at the head of the installation (see page E-26).

The authorised settings are:

#### ■ operating current threshold

the maximum setting is  $I_{\Delta n} = 50 \text{ V}/10 \Omega = 5 \text{ A}$

**Note:** even though the earthing resistance of the main LV switchboard is  $1 \Omega$ , the RCD at the head of the installation must protect against faults occurring downstream whatever their position and the greatest earth resistance must therefore be considered, i.e.  $10 \Omega$ . (see page E-26)

#### ■ non-operating time (time delay)

the non-operating time must not exceed  $\Delta t = 1 \text{ s}$  (see page E-25).

### Protection against direct contact

Protection against direct contact must mainly be provided on circuits supplying the users in the workshops, in particular for the outlets. It is provided by instantaneous high-sensitivity 30 mA RCDs.

## Protection implementation

### Taking leakage currents into account

The leakage currents must be measured or estimated. Tables provide estimates for various loads (see page E-12) and for computer hardware (see page E-39).

The minimum setting for an RCD is:

$I_{\Delta n} > 2 I_L$  (where  $I_L$  is the total leakage current downstream of the RCD).

■ On the circuits supply power outlets, the leakage current must therefore be limited to  $I_L < 30 \text{ mA}/2 = 15 \text{ mA}$

e.g. downstream of the 30 mA ID63, no more than 4 PCs can be installed (from the table on page E-39, the estimated leakage current for a PC is 3.5 mA, giving  $4 \times 3.5$  for 4 PCs =  $14 \text{ mA} < 15 \text{ mA}$ )

■ On the other circuits, the RCD thresholds are set to provide protection against direct contact. The sum of the leakage currents must be less than  $I_{\Delta n}/2$

e.g. downstream of the NSX250 in Workshop B, there are 20 frequency converters equipped with 100 nF filters (see page E-12), corresponding to a leakage current of approximately 21 mA per converter. The sum of the leakage currents is therefore 420 mA. The Vigicompact must therefore be set to at least  $2 \times I_L$ , i.e. 1 A.

### Taking discrimination into account (see page E-24)

#### ■ Current-based discrimination

The following two conditions must be satisfied:

- $I_{\Delta n}$  of upstream RCD  $> 2 I_{\Delta n}$  of downstream RCD (discrimination requirement)
- $I_{\Delta n}$  of upstream RCD  $> 2 I_L$  (leakage current requirement)

e.g. the Vigicompact NSX250 is upstream of Acti 9 and Vigicompact C60 or iC60 RCDs set to 30 mA or 300 mA. The total leakage current is estimated to be 420 mA.

The 1 A setting satisfies both earth leakage and discrimination requirements

#### ■ Time-based discrimination

The following condition must be satisfied:

upstream non-operating time  $>$  downstream total operating time (relay + breaking device).

Given that downstream protection is provided by Acti 9 and Vigicompact devices, it is sufficient to set the upstream Vigicompact time delay one setting higher, i.e. setting I (60 ms).

#### ■ Check

The Vigicompact protection settings determined in this way must still satisfy the requirements of the standards as indicated above for the operating current threshold and non-operating time.

e.g. the protection of persons against indirect contact in Workshop B complies if:

$I_{\Delta n} < 5 \text{ A}$  and  $\Delta t < 1 \text{ s}$

The Vigicompact settings of  $I_{\Delta n} = 1 \text{ A}$  and  $\Delta t = 60 \text{ ms}$  are therefore compliant.

**Note 1:** with RCDs from the Vigirex, Vigicompact and Acti 9 range, the maximum time delay is 1 s; the  $\Delta t$  condition is therefore always satisfied.

**Note 2:** if the operating current condition is not satisfied, a Vigirex RCD can be used.

e.g. the RCD at the head of the installation must normally be set to meet the general discrimination requirements for RCDs, i.e. 6A, however this is not compatible with the protection of persons (5 A) for this installation. By using a Vigirex RCD, this problem is avoided because special characteristics of Vigirex RCDs ensure discrimination down to  $1.5 I_{\Delta n}$  downstream, i.e. 4.5 A.

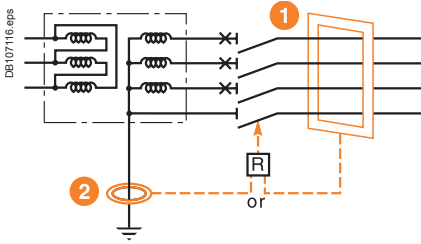

Installation of the Vigirex measurement toroid at the head of an installation.

### Single-source diagram RCD at the head of an installation

The fault current on the transformer incomer can be calculated two ways:

- by measuring the sum of the currents in the live conductors (3 Ph + N)
- by measuring the fault current directly on the earthing conductor.

The latter method is useful because at the head of sizeable installations, the cables or busbars are large and it is difficult to install the measurement toroid.

	Advantages	Disadvantages	Comments
1 Rectangular sensor	Standard solution Tests in factory	Difficult to install	Good solution for new installations
2 Measurement toroid on earthing conductor	Size of toroid Easy installation at any time	"Custom" solution Special toroid mounting and wiring outside the switchboard On-site tests	Good solution for existing installations Possible only with RCDs with separate toroid

*Note:* the rectangular sensors in the Vigirex range are specifically designed for this type of installation.

### Multi-source diagram with TT system

At this level in the installation and in the event of an insulation fault, continuity of service is obtained by:

- discrimination between the RCDs for faults on the output circuits
- source redundancy for faults on the main busbars.

The sources must not be disconnected simultaneously.

#### Each source has a separate earth electrode

The measurement toroid for the header RCD is positioned in the same manner as for a single source.

#### ■ The two sources are never coupled

This is the typical situation for a normal source with an engine generator set as a backup source.

Each RCD monitors the fault current in the part of the installation in which it is installed.

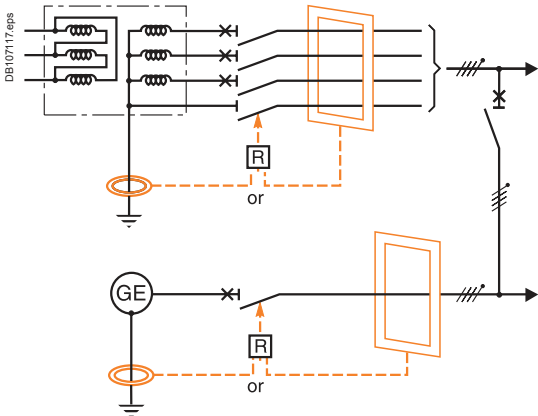

The two sources are never coupled.

#### ■ The two sources may be coupled

It is not possible to use the system presented above because if a fault occurs, each of the measurement toroids for the RCDs detects only a part of the fault current, i.e. the protection of persons is not correctly ensured.

To correctly set up protection using an RCD, the two earth electrodes must both be run through the measurement toroids for the two header RCDs.

This diagram is in fact identical to that for a single-source system with two parallel-connected transformers (as concerns insulation faults).

*Note:* in the event of a fault, even when the sources are not coupled, the two protection devices trip. There is no discrimination in clearing the faulty source. This system downgrades the continuity of service.

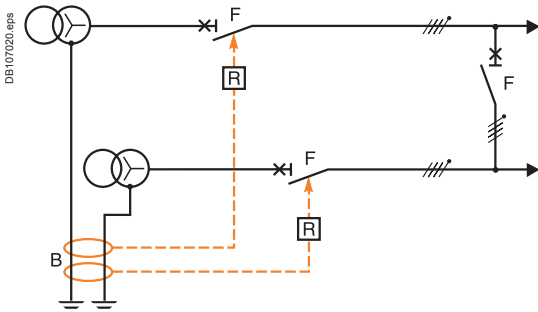

The two sources may be coupled.

### The sources are connected to the same earth electrode

Caution is required in setting up the RCDs.

#### ■ The two sources are never coupled

Installation of the toroids at points A ensures correct monitoring of the insulation fault and discrimination in clearing the faulty part of the installation.

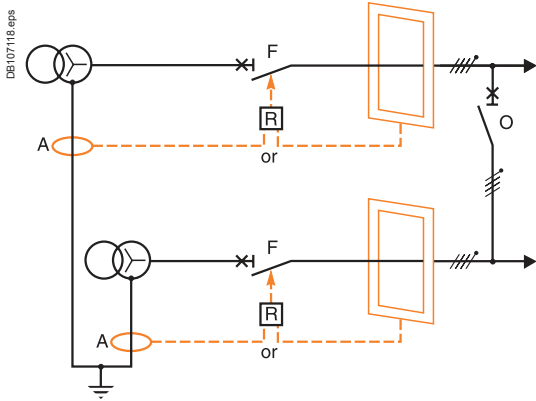

The two sources are never coupled.

#### ■ The two sources may be coupled

The same conditions (each source has an earthing conductor, two sources with a closed coupling) means the measurement toroids must be installed at point B, on the common earth electrode.

This system has the same disadvantages, i.e. no discrimination in clearing the sources.

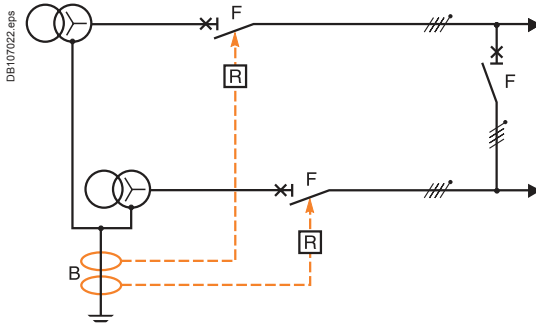

The two sources may be coupled.

#### IMPORTANT

Coupling may be carried out by a source coupling device (the most frequent case), particularly when there is a DC bus downstream.

Example. DC bus shared by a number of rectifiers.

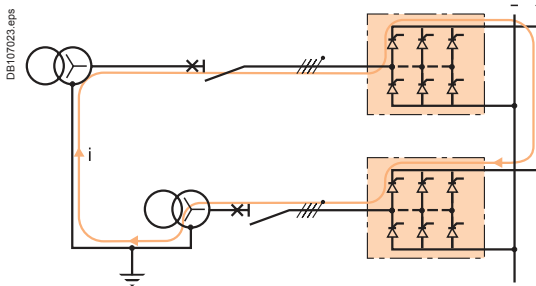

Coupling via the load and DC bus.

### Multi-source diagram with TN system

Use of RCDs at the head of an installation with the TN system for the protection of persons is uncommon. The reason for their use can be the long length of cables and/or the low  $I_{sc}$  value.

It is possible to use them for the protection of property when the fault impedance is not controlled. The functional diagram is identical to that for a multi-source TT system with a single earth electrode. The limiting conditions mentioned above are identical (except for the fact that the sensitivity of the settings is very low and thus not comparable with the natural leakage currents or the coupling currents). The main limiting factor is the possible flow of neutral current in the earthing circuits. To ensure discrimination and avoid malfunctions, each situation must be carefully studied. For further information, see guide no. 2 "Ground Fault Protection".

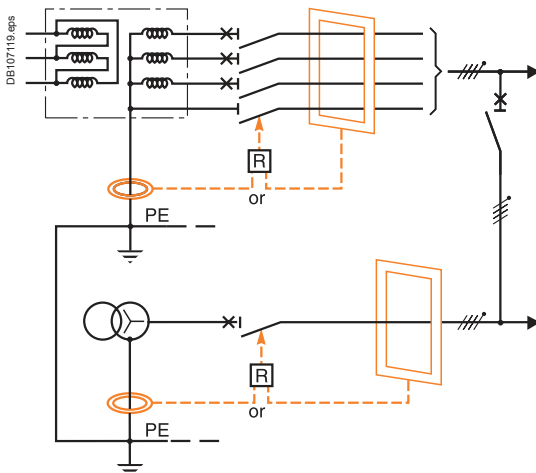

Multi-source diagram with TN system.

### Recommendations for toroid installation

For measurements of residual currents using RCDs with separate toroids, a number of simple rules must be observed to avoid nuisance tripping, i.e.:

- install the conductors in the measurement toroids
- take into account the operational current of the toroids
- install the toroid on a straight section of the conductors
- use a magnetic ring if:
  - transient currents are high ( $\approx 6 I_n$  where  $I_n$  is the maximum permissible continuous current for the toroid)
  - the application requires high sensitivity (eg.  $I_{\Delta n} = 30 \text{ mA}$ )
  - the nominal current for the application is in the neighbourhood of the maximum permissible current of the toroid.

Further information is provided on these rules in the section on device installation.

### Rated operational current of the sensors

Particular precautions may be required for toroid installation. This is because high currents "but not an insulation fault" can locally saturate the magnetic circuit of the toroid, creating abnormal flows that are interpreted on the secondary winding as zero-sequence currents.

The rated operational current for the toroids used with Vigirex devices:

- is indicated for the minimum setting value at 30 mA
- takes into account inrush currents (up to  $6 I_n$ ).

### Selection of toroids and rectangular sensors depending on the power circuit

See [page B-9](#).

Example 1. A motor feeder (30 kW/57 A at 400 V) must be monitored by a Vigirex device with a toroid having a minimum diameter of 30 mm (TA30).

This means that the device may be set to 30 mA instantaneous without risk of nuisance tripping.

The rated operational current must be taken into account to avoid nuisance tripping, however, higher currents will not damage the toroid.

Example 2. On the motor feeder mentioned in example 1, the inrush current is, in fact, significantly higher than  $6 I_n$ .

To avoid possible tripping, it may be necessary to:

- use a toroid having a larger diameter
- set up a time delay complying with the safety rules ( $< 1 \text{ s}$ ) and discrimination requirements for the upstream RCDs.

These two measures may be implemented simultaneously.

DB107433.eps

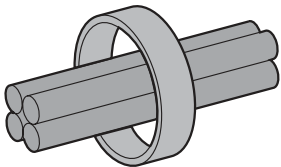

Magnetic ring for conductors.

## Disturbed environments

Measurements in disturbed environments may require special precautions:

- greater distance between the toroid wires and power circuits
  - use of shielded, twisted cables with the shielding connected at each end.
- It is necessary to check that equipotential bonding exists between the exposed conductive parts to which the shielding is connected on the toroid side and those to which the shielding is connected on the Vigirex side.

If that is not the case, the shielding may act as the equipotential bond for the low-frequency currents and that is not its job. There is the risk that the cable may be damaged and/or the Vigirex device may malfunction. A PE conductor is required for equipotential bonding.

- Reduction to the shortest length possible for the cable between the toroid and the relay
- Use of a dedicated supply with galvanic isolation to eliminate conducted disturbances.

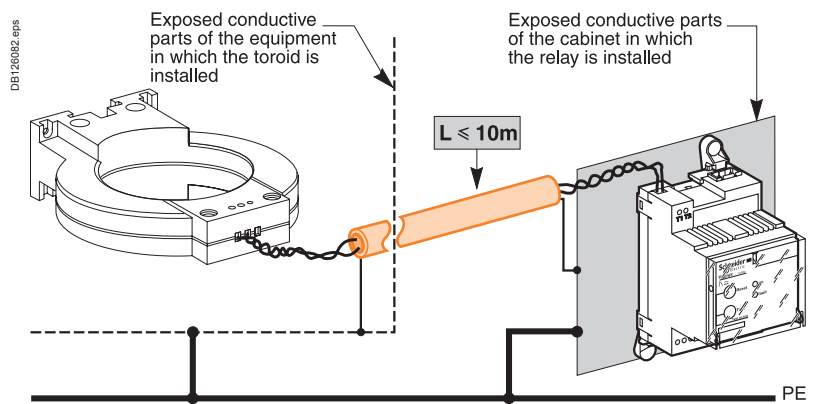

### Combinations of RCDs

**It is possible to combine different types of RCDs (type AC, A and B)?**

To confirm the validity of the combination, it is necessary to check the type of insulation fault downstream that the RCD combination will have to monitor. If each of the RCDs in the combination is compatible with all the possible types of faults, discrimination between the RCDs is ensured, even when different types are employed, as long as the discrimination rules are observed.

The table below sums up the possible combinations:

		Possible combinations of RCD types			Optimised solutions for type B fault
<p>DB107121.eps</p>	<b>RCD1 type</b>	AC or A or B	A or B	B	A
	<b>RCD2 type</b> (1)	AC or A or B	A or B	B	B + isolating transformer or A + class 2 insulation
	<b>Type of fault</b>	AC	A	B	B

(1) Capable of handling the fault.

#### Technical comments

Analysis of a combination with a type A RCD1 upstream of a type B RCD2 in the event of a type B insulation fault.

Even if it is not dangerous, a type B insulation fault causes the flow of DC current that may exceed 6 mA (the limiting value for DC current for type A RCDs). This DC current may saturate the magnetic circuit of the measurement toroid for RCD1, thus blocking detection and relay actuation if a dangerous fault occurs in another part of the installation. This blocking of detection does not depend on the RCD1 current setting, which may be significantly higher than that for RCD2 (for example,  $I_{\Delta n1} = 30\text{ A}$ ,  $I_{\Delta n2} = 30\text{ mA}$ ).

#### Solutions

The use of type B RCDs is specific to certain loads. For this reason, there are two solutions to eliminate the flow of DC current on the distribution system:

- isolate the loads in question using an isolating transformer
- isolate the loads likely to cause a type B fault using class 2 insulation.

The two solutions may be implemented simultaneously.

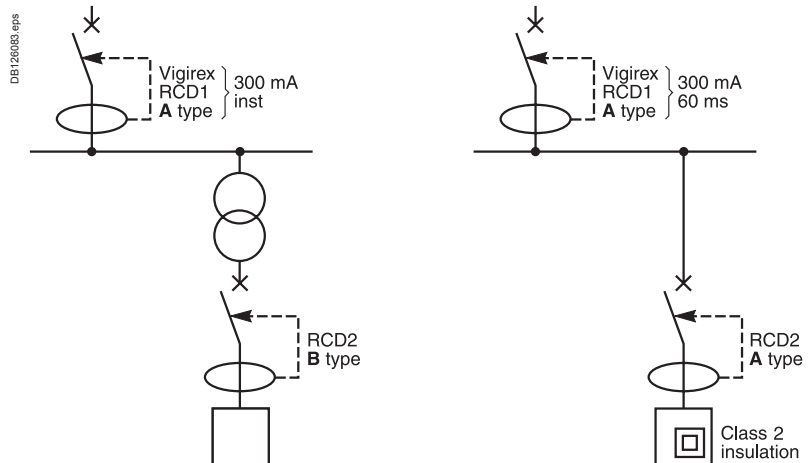

Implementation examples.

**Note:** if an isolating transformer is used, discrimination between RCD1 and RCD2 is of course excellent.

## RCD-device settings in installations with high leakage currents

### TT system

#### ■ Maximum current setting $I_{\Delta n1}$

It is first necessary to check the earthing resistance ( $R_T$ ) of the exposed conductive parts of the connected loads. The maximum setting value for RCD  $I_{\Delta n1}$  is provided by  $U_L/R_T$  (where  $U_L$  is equal to 50 V for standard environments and 25 V for humid environments).

#### ■ Minimum current setting $I_{\Delta n2}$

It is then necessary to determine for the various parts of the installation protected by a given RCD the natural leakage current (low because the leakage capacitances are balanced) and the intentional leakage current (caused by the load filters). The table below provides typical values for the leakage currents of loads causing particularly high levels of disturbances.

If  $I_l$  is the value in question, the minimum setting  $I_{\Delta n2}$  of the RCDs is  $2 I_l$ .

**Note:** with the specific factory setting and the operating tolerances under worst-case conditions (temperature, auxiliary-source voltage, etc.), Vigirex can be used with a guaranteed non-operating threshold of  $0.8 I_{\Delta n}$ . The minimum setting for a Vigirex devices can be as low as  $I_l/0.8$ , i.e.  $1.25 \times I_l$ .

#### ■ Table for leakage currents

Electrical equipment	Measured leakage current (mA)
Fax machine	0.5 to 1
Printer	< 1
Workstation (UC, screen and printer)	1 to 3
Photocopy machine	0.5 to 1.5
Floor heating	1 mA / kW
Single-phase and three-phase filters	1 mA / load
Computer equipment as per standard IEC 60950	Maximum leakage current (mA)
Class 2 All equipment	0.25
Class 1 Portable	0.75
Class 1 A-type fixed or mobile	3.5
Class 1 B-type fixed	3.5 or 5 % In

#### ■ $I_{\Delta n2} \ll I_{\Delta n1}$ (slightly disturbed system)

There are no problems with malfunctions if the discrimination rules are observed.

#### ■ $I_{\Delta n2} \approx I_{\Delta n1}$ to avoid nuisance tripping. There are three possible solutions:

- segment the installation to reduce the leakage currents in each part
- install an isolating transformer for sets of loads causing particularly high levels of disturbances
- set up the TN-S system for all or a part of the installation. This is possible if the disturbing loads can be identified and located (the case for computer equipment).

### IT system

The major characteristic of the IT system is its capacity to continue operation after a first insulation fault. However, this insulation fault, though not dangerous, causes a leakage current in the natural capacitances (high because unbalanced) and intentional capacitances. This current may reach or exceed 1 A. If RCDs are required, they must imperatively be set to a value double that of the leakage current (see § 531.2.5 of standard IEC 60364-553).

#### ■ Table for leakage currents depending on system capacitance

System leakage capacitance ( $\mu\text{F}$ )	1 <sup>st</sup> fault current (A)
1	0.07
5	0.36
30	2.17

Table drawn from figure 5 in the Cahier Technique document 178.

**Note:** 1  $\mu\text{F}$  is the typical leakage capacitance of 1 km of four-core cable.

For a load causing high leakage currents, the installation segmenting technique mentioned above is often used.

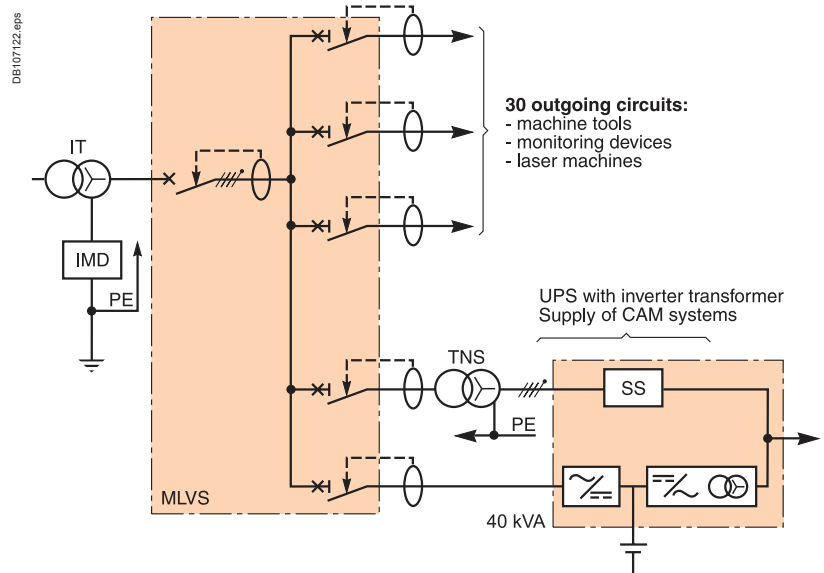

Distribution system in a factory with a TNS segment for the management IT system.

IMD: insulation-monitoring device.

# Leakage-current monitoring using RCDs

An isolation fault causes a zero-sequence leakage current and, depending on the system earthing arrangement, tripping of the protection device specified by the installation rules.

But a zero-sequence current can also be caused by:

- intentional leakage current, e.g. a high-frequency filter installed between the system and earth
- non-dangerous leakage currents, e.g. a progressive insulation fault or an insulation fault on the neutral conductor.

These two types of leakage current do not create dangerous situations and the continuity of service must be maintained, consequently the protection devices must not react and operation must continue.

These currents can, however:

- degenerate and become dangerous (risk of fire or electrocution), and as a result force the operator to shut down the dangerous part of the installation
- create disturbances on the distribution system leading to the malfunction of sensitive equipment.

Measurement of the leakage current is the means to prevent the risk of a dangerous fault.

## Monitoring the neutral conductor in TN-S systems

In the TN-S system, the neutral conductor is connected to the PE at the head of the installation. The neutral conductor can be accidentally earthed due to an insulation fault.

### ■ Safety of life and property

There is no problem because no dangerous touch voltages are created given that the natural voltage of the neutral conductor is the same as that of the PE.

### ■ Power quality

In the TN-S system, accidental earthing of the neutral conductor can cause malfunctions due to the flow of currents from the neutral conductor to the protective conductor and the exposed conductive parts. This type of fault in fact transforms the TN-S system into a TN-C, which is forbidden for the supply of sensitive equipment.

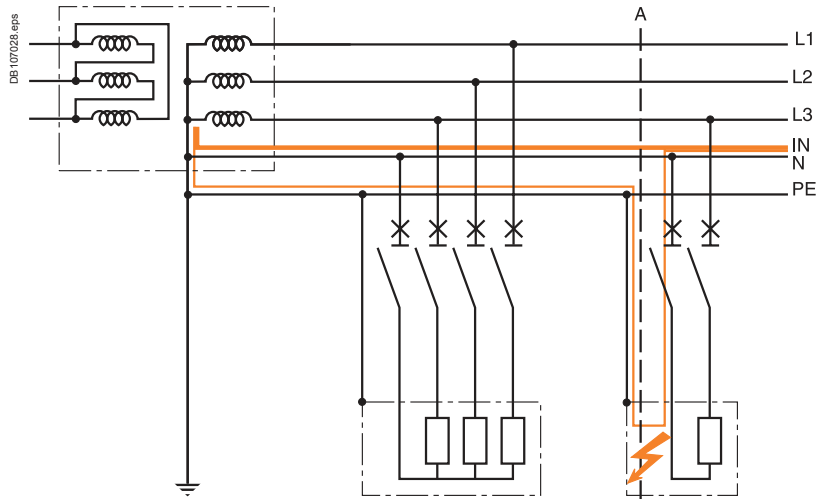

Insulation fault on the neutral conductor. The system is TN-C upstream of A.

## Tolerance for an insulation fault on the neutral conductor depending on the system earthing arrangement

	TN-C	TN-S	TT	IT
Equipment sensitive to EM disturbances	Forbidden PE and neutral are the same	OK But PE and neutral must not be in contact	Excellent No problem even if PE and neutral are in contact	Excellent No problem even if PE and neutral are in contact

## Consequences of an isolation fault on the neutral conductor

In the TN-S system, an earth fault on the neutral causes:

- "noise" in the earthing circuits for sensitive equipment
- emission of EM fields (disturbances).

**Note:** the currents in the exposed conductive parts are zero-sequence currents, i.e. with significant EM radiation. What is more, computer equipment is sensitive. A force of 1 A at a distance of one meter disturbs the screen of a PC.

- differences in potential between the 0V of the different equipment.

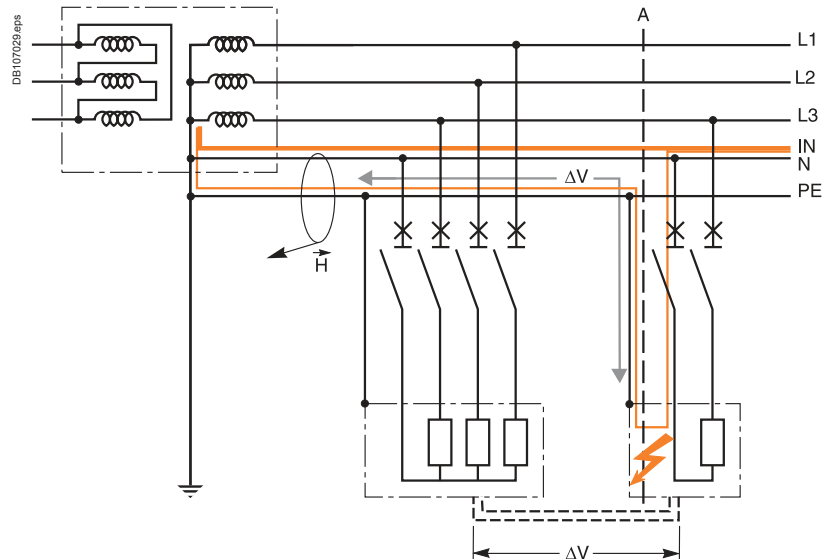

Effects of a fault on the neutral conductor in the TN-S system.

The gravity of these phenomena is increased by:

- the presence of non-linear loads with high THDI values
- the presence, often significant, of third-order harmonics and their multiples.

In this case, the neutral current represents from 50 to over 100 % of the current in the phases.

**These new constraints require the use of a device to monitor the zero-sequence currents.**

---

## Measurement of leakage currents

### ■ Management of leakage currents

RMH and RM12T devices provide the means to monitor circuit loading and equipment layout and make sure the leakage currents are distributed correctly and do not disturb the protection system.

### ■ Table for leakage currents

Electrical equipment	Measured leakage current (mA)
Fax machine	0.5 to 1
Printer	< 1
Workstation (UC, screen and printer)	1 to 3
Photocopy machine	0.5 to 1.5
Floor heating	1 mA / kW
Single-phase and three-phase filters	1 mA / load
Computer equipment as per standard IEC 60950	Maximum leakage current (mA)
Class 2 All equipment	0.25
Class 1 Portable	0.75
Class 1 A-type fixed or mobile <sup>(1)</sup>	3.5
Class 1 B-type fixed <sup>(2)</sup>	3.5 or 5 % In

*(1) A-type equipment: equipment intended for connection to the electrical installation of building via a non-industrial outlet, a non-industrial connector or both.*

*(2) B-type equipment: equipment intended for connection to the electrical installation of building via an industrial outlet, an industrial connector or both in compliance with standard IEC 60309 or similar national standards.*

In addition to sensitive equipment and loads, the lighting circuits must also be monitored.

The starters for fluorescent lighting have more or less significant levels of natural leakage current. Damage to a starter often causes a major increase in the leakage current.

# Leakage-current monitoring using RCDs

## RHUs and RHU application diagram

### Small distribution systems

The RHUs and RHU may be used to measure the leakage currents.

#### Selection table

Products	Part no.
RHUs or RHU	28573 or 28560
A-type toroids <sup>(1)</sup>	50437 to 50442
TOA-type toroids <sup>(2)</sup>	50420 or 50421

■ New. ■ Renovation.

<sup>(2)</sup> In this case, the diameter of the toroid is generally much smaller than <sup>(1)</sup>.

#### Setting

Depending the leakage currents of the supplied equipment, from 30 mA to 1 A.

#### Installation

- Head of LV distribution system

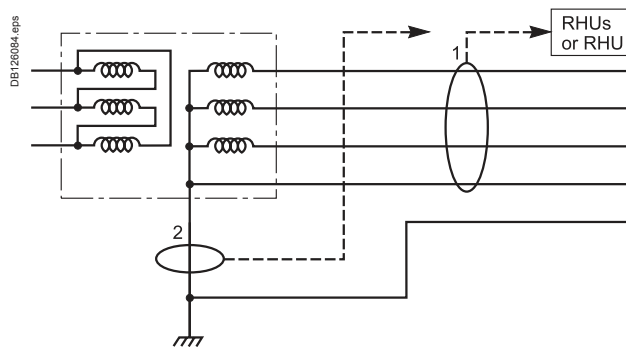

Small distribution systems.

- The natural leakage currents caused by lighting are significant and interfere with insulation monitoring of the monitored equipment. Measurements are made directly on the monitored equipment.

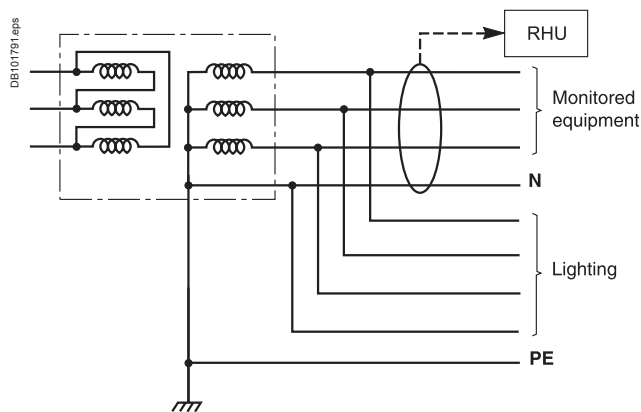

# RMH application diagram

## Computer rooms

### Selection table

Products	Part no.
RMH	28563
RM12T	28566
A-type toroids <sup>(1)</sup>	50437 to 50442
TOA-type toroids <sup>(2)</sup>	50420 or 50421

New.
  Renovation.

<sup>(2)</sup> In this case, the diameter of the toroid is generally much smaller than <sup>(1)</sup>.

### Setting

These relays are installed in situations where the leakage currents can be high, up to 5 % of the rated load current:

- a few amperes for the shielding earthing
- from 0.3 to 1 A for each device and the lighting.

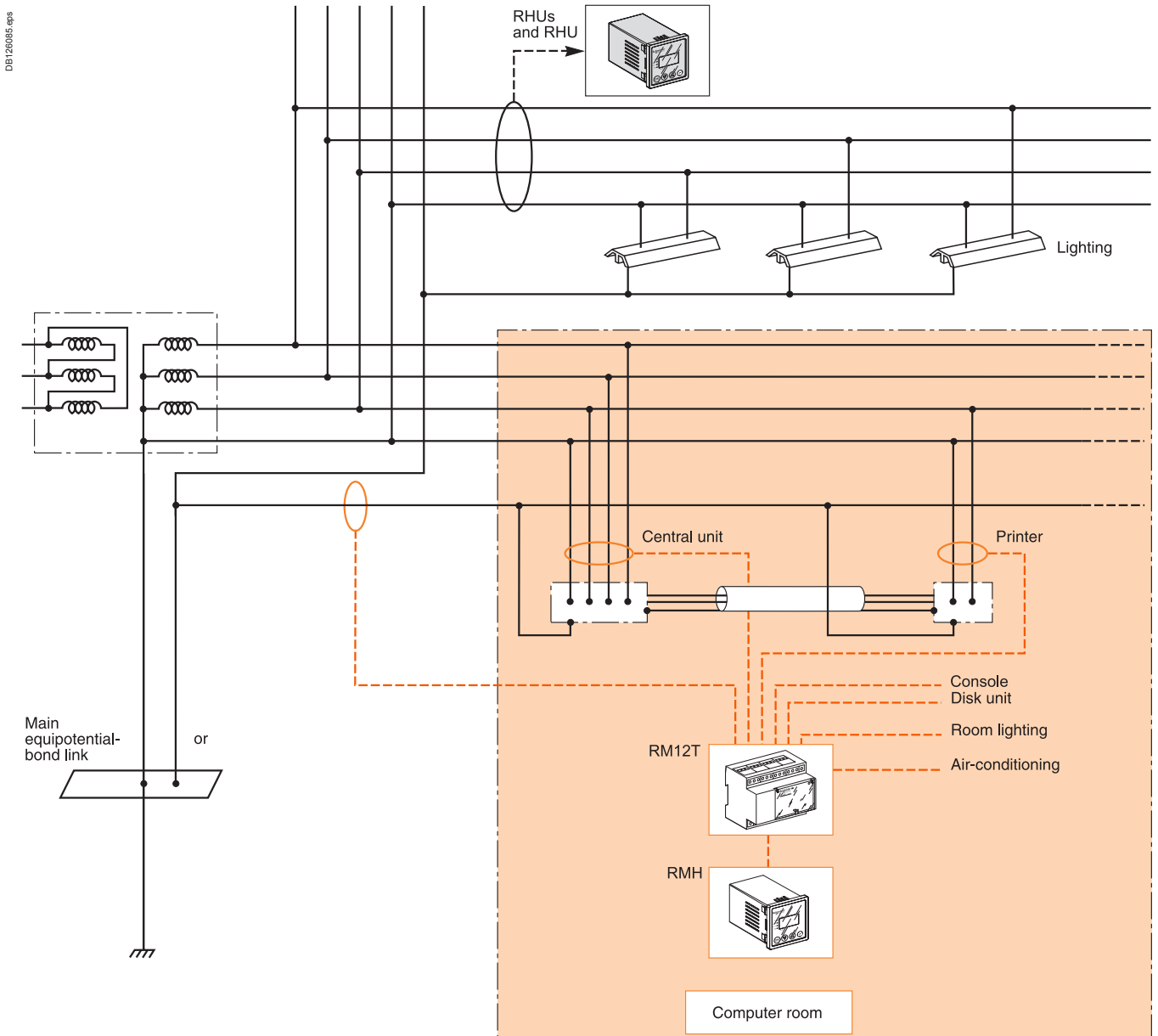

Computer room.

# Leakage-current monitoring using RCDs

## PC network

### Selection table

Products	Part no.
RMH	28563
RM12T	28566
A-type toroids <sup>(1)</sup>	50437 to 50442
TOA-type toroids <sup>(2)</sup>	50420 or 50421

New
  Renovation

*(2) In this case, the diameter of the toroid is generally much smaller than (1).*

- Check on the overall leakage current, from 1 to a few amperes
  - Check on the distribution of the leakage currents in each distribution system,  $I_{leakage} = 300 \text{ mA to } 1 \text{ A}$
  - Fluorescent lighting from 0.3 to 1 A.
- If there is a significant difference between each supply, reconsider the supply for the workstations.

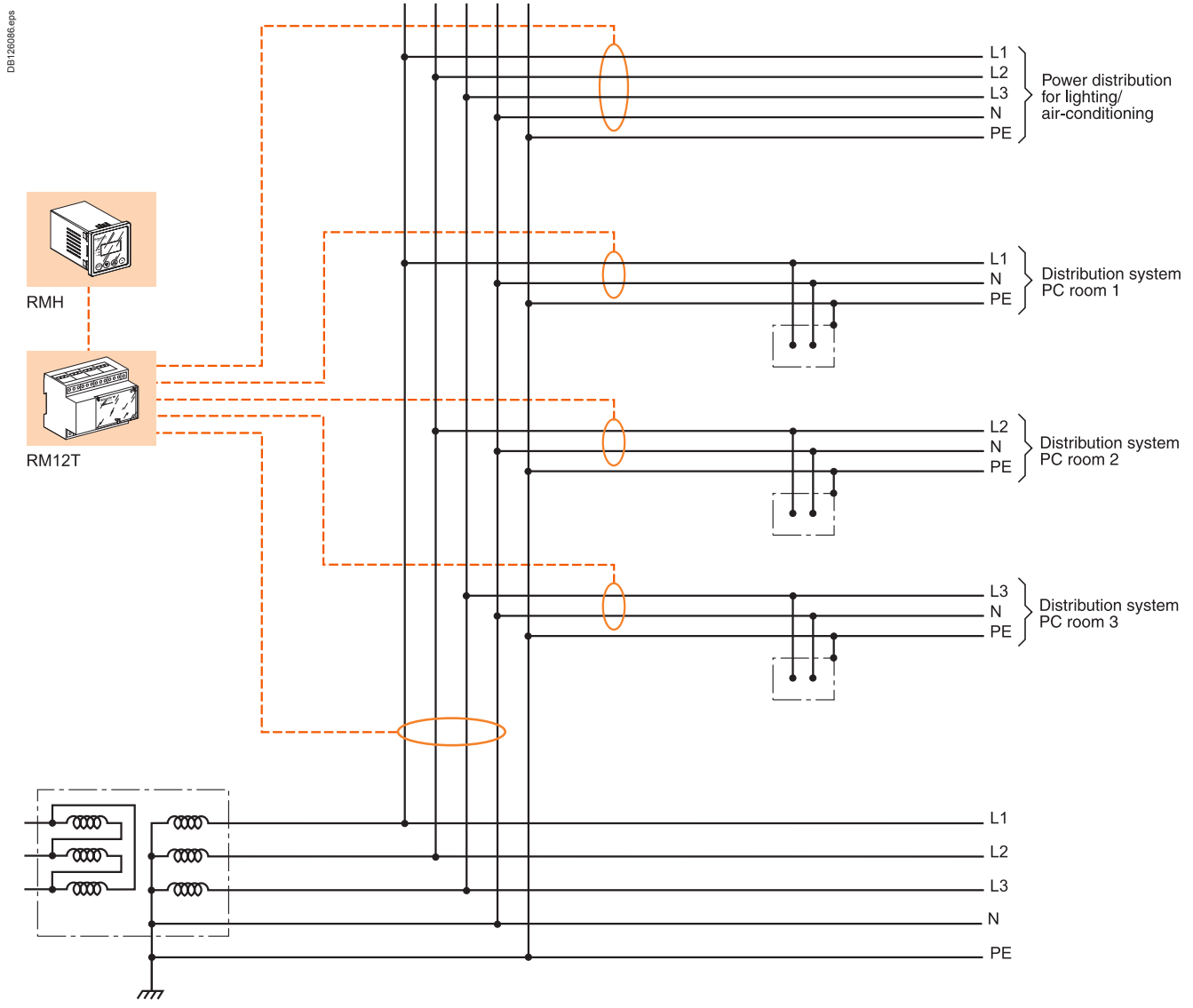

PC network.

# Tripping curves and frequency filtering

RH10, RH21, RH68, RH86 and RH99

## Instantaneous relay, $I\Delta n$ setting = 30 mA

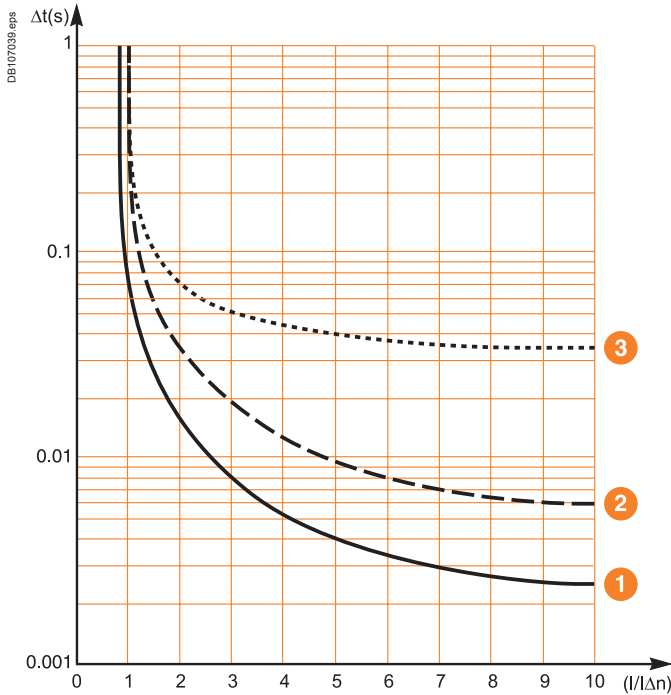

- 1 Non-operating time.
- 2 Operating time.

## Instantaneous relay, $I\Delta n$ setting > 30 mA

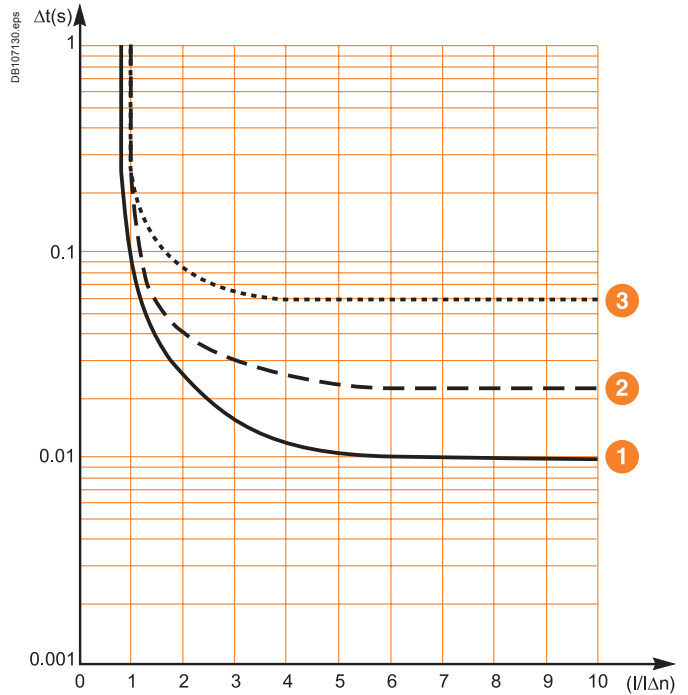

- 3 Total break time.

## Frequency filtering

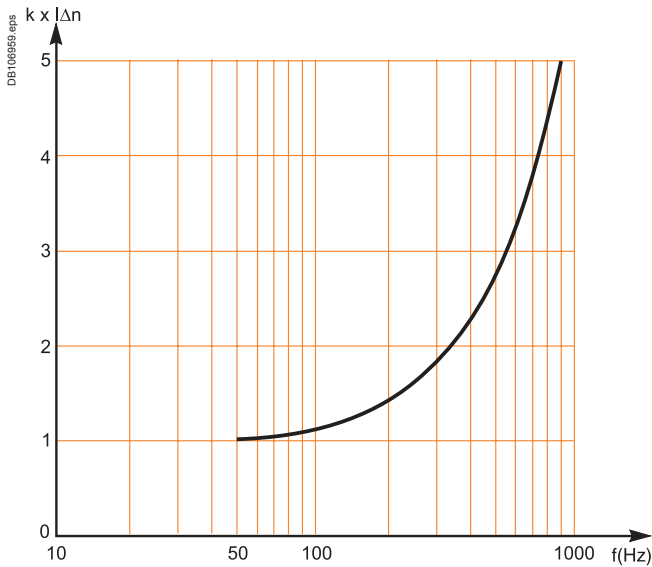

### Example

At 50 Hz, the tripping threshold is  $I\Delta n$ .  
At 900 Hz, the tripping threshold is  $k \times I\Delta n$  (where  $k = 5$ ).

## Delayed relay for $I\Delta n > 30$ mA

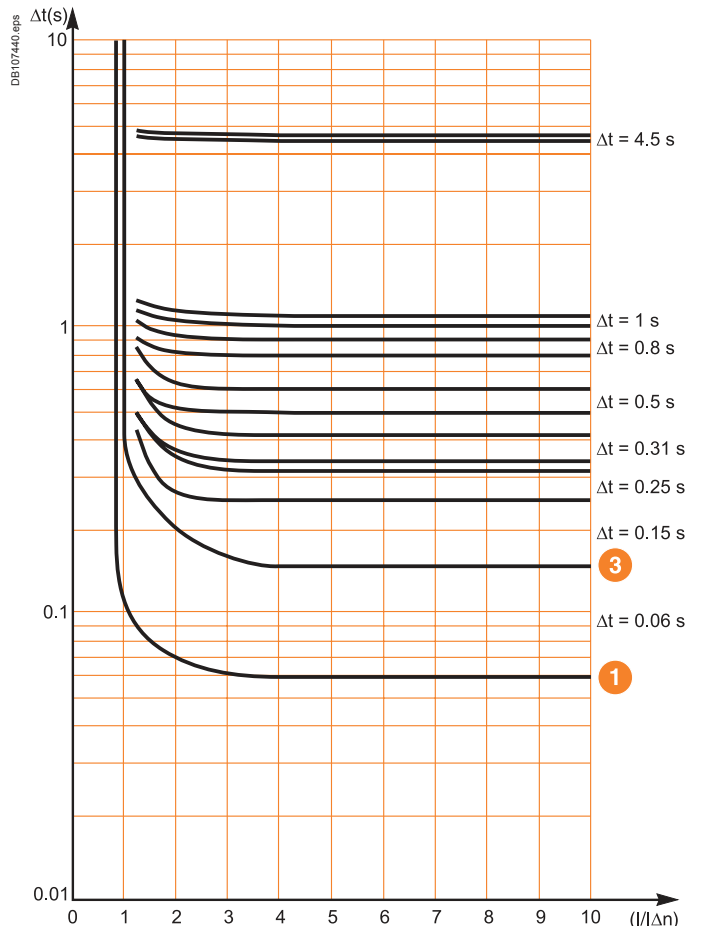

# Tripping curves and frequency filtering

## RH197M

Instantaneous relay,  $I\Delta n$  setting = 30 mA

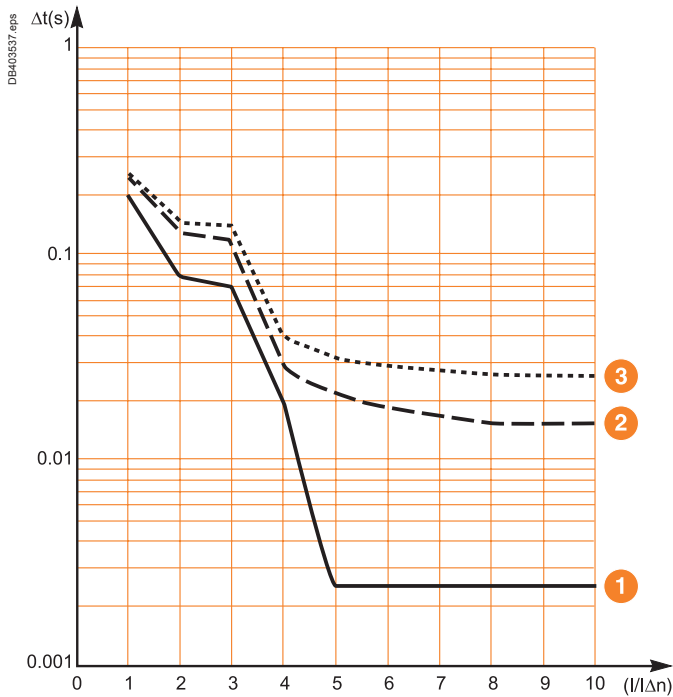

- 1 Non-operating time.
- 2 Operating time.

Instantaneous relay,  $I\Delta n$  setting > 30 mA

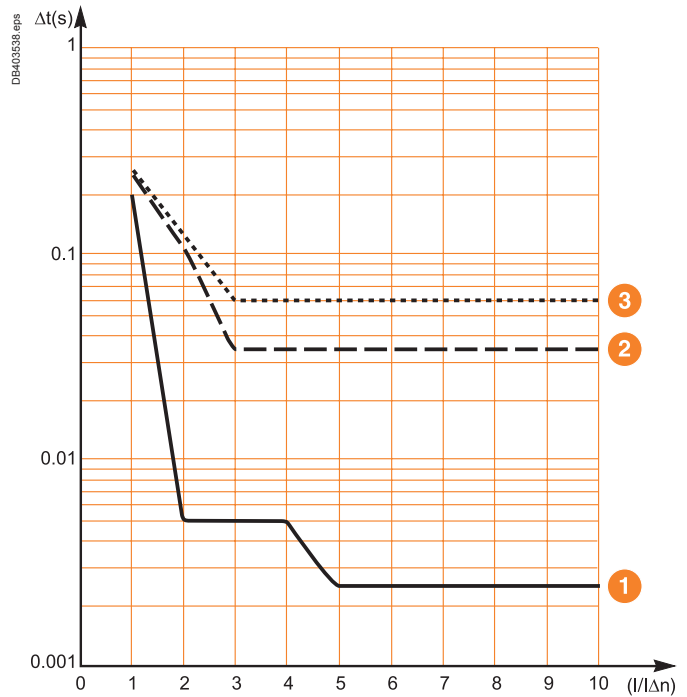

- 3 Total break time.

Frequency filtering

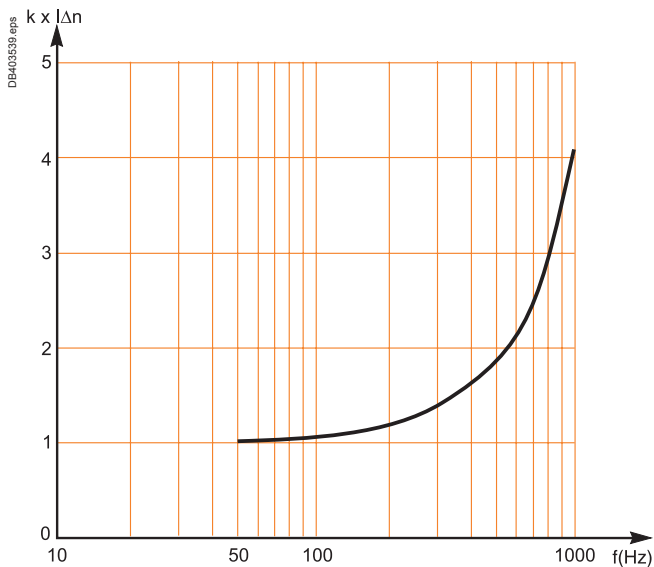

**Example**

At 50 Hz, the tripping threshold is  $I\Delta n$ .  
 At 900 Hz, the tripping threshold is  $k \times I\Delta n$  (where  $k = 5$ ).

Delayed relay for  $I\Delta n > 30$  mA

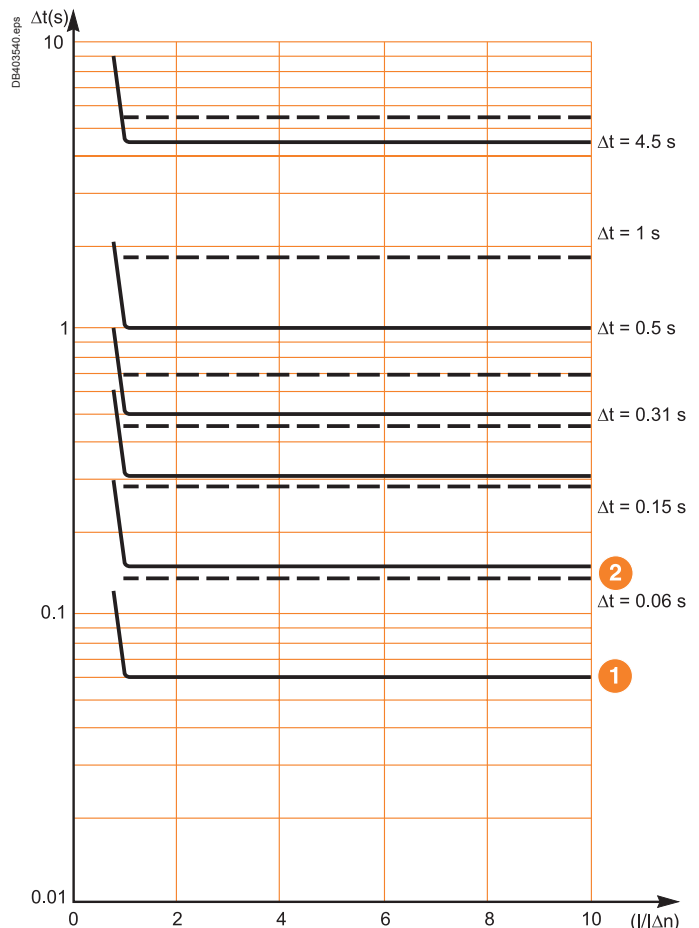

# RH197P

## Instantaneous relay, $I\Delta n$ setting = 30 mA

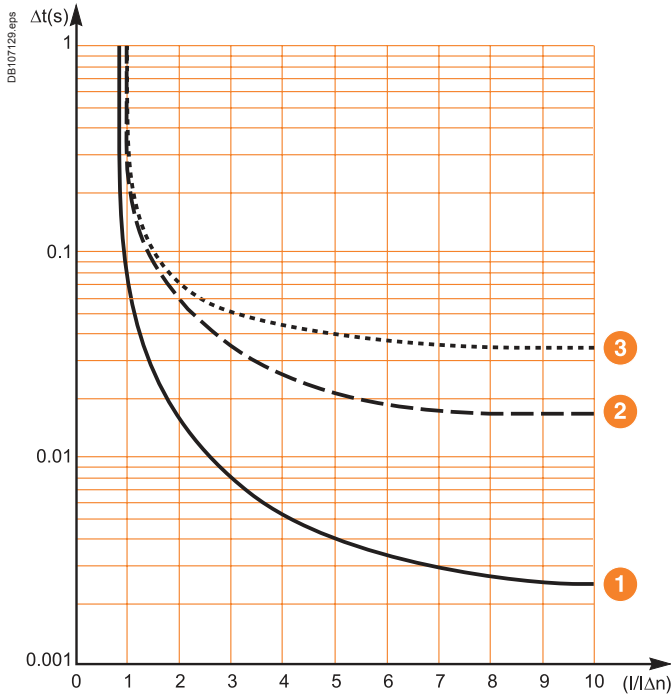

- 1 Non-operating time.
- 2 Operating time.

## Instantaneous relay, $I\Delta n$ setting > 30 mA

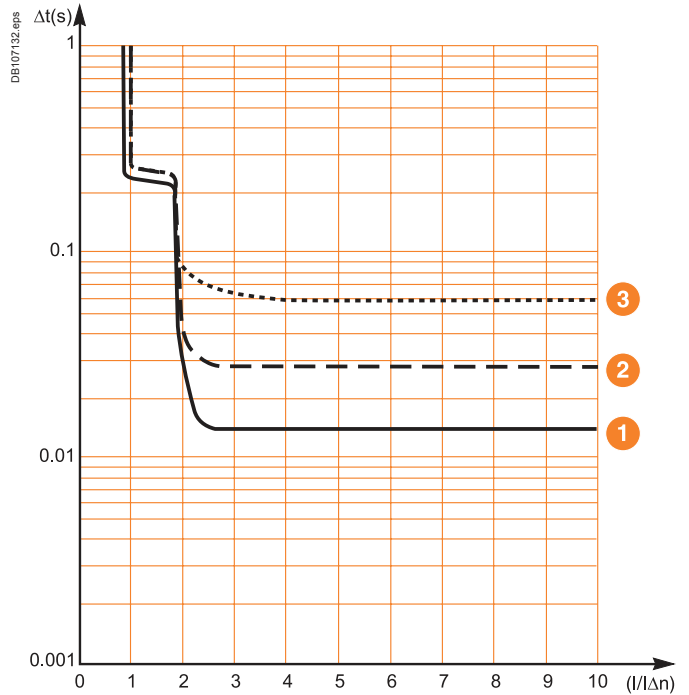

- 3 Total break time.

## Frequency filtering

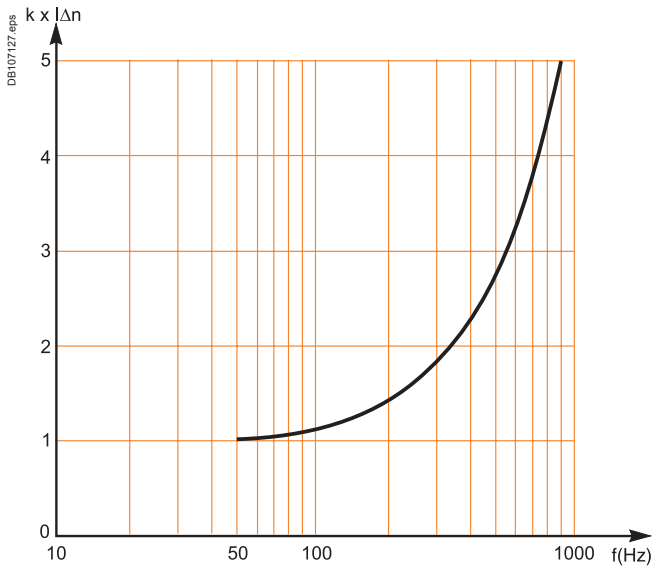

### Example

At 50 Hz, the tripping threshold is  $I\Delta n$ .  
At 900 Hz, the tripping threshold is  $k \times I\Delta n$  (where  $k = 5$ ).

## Delayed relay for $I\Delta n > 30$ mA

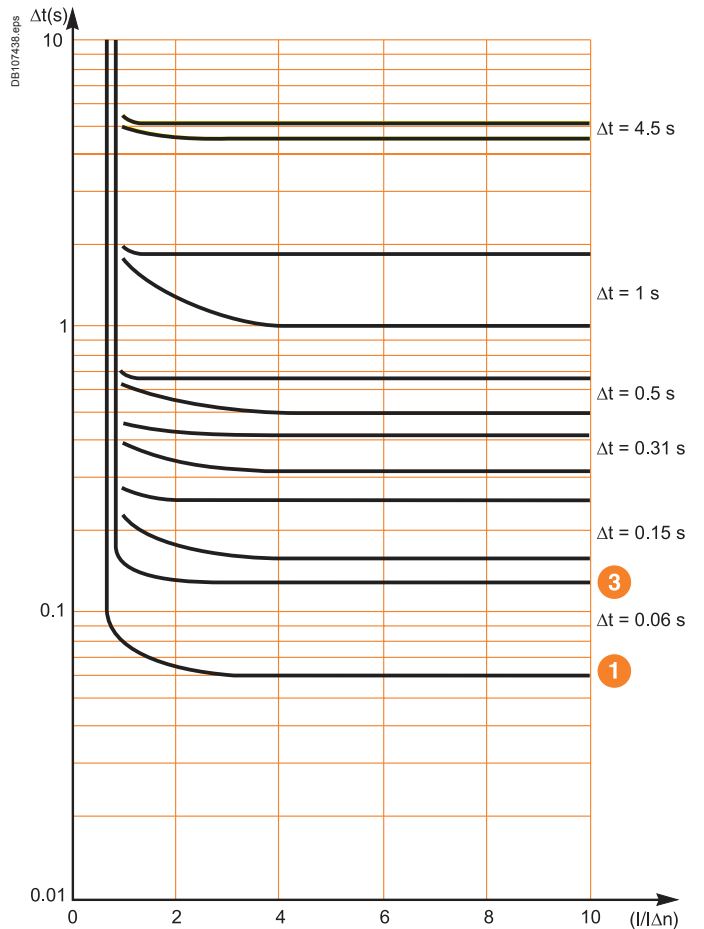

- 3
- 1

# Tripping curves and frequency filtering

RHUs and RHU

Instantaneous relay,  $I\Delta n$  setting = 30 mA

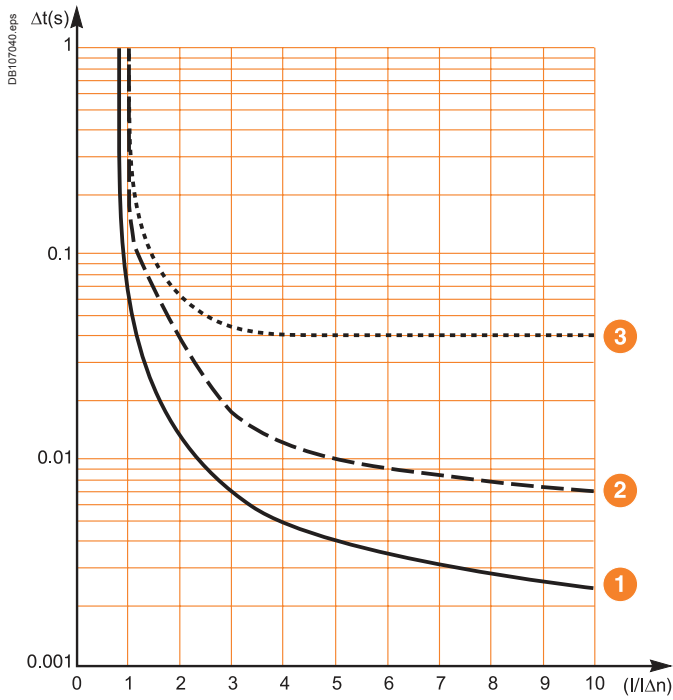

- 1 Non-operating time.
- 2 Operating time.

Instantaneous relay,  $I\Delta n$  setting > 30 mA

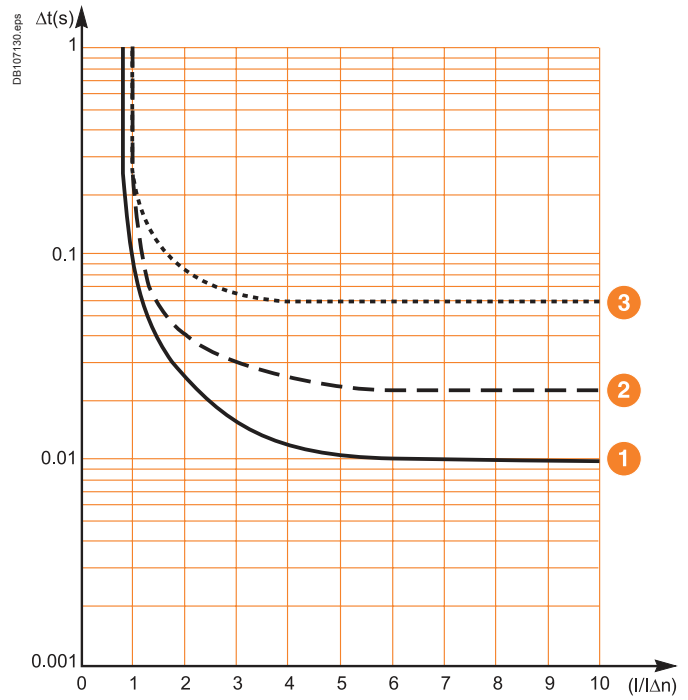

- 3 Total break time.

Frequency filtering

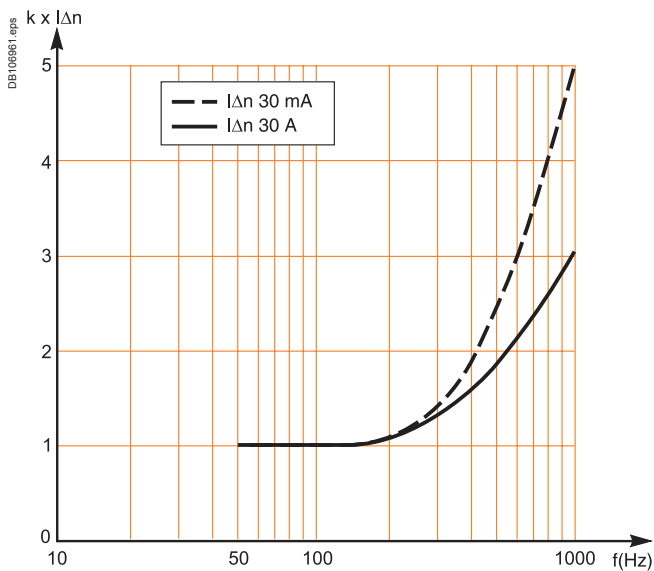

Delayed relay for  $I\Delta n > 30$  mA

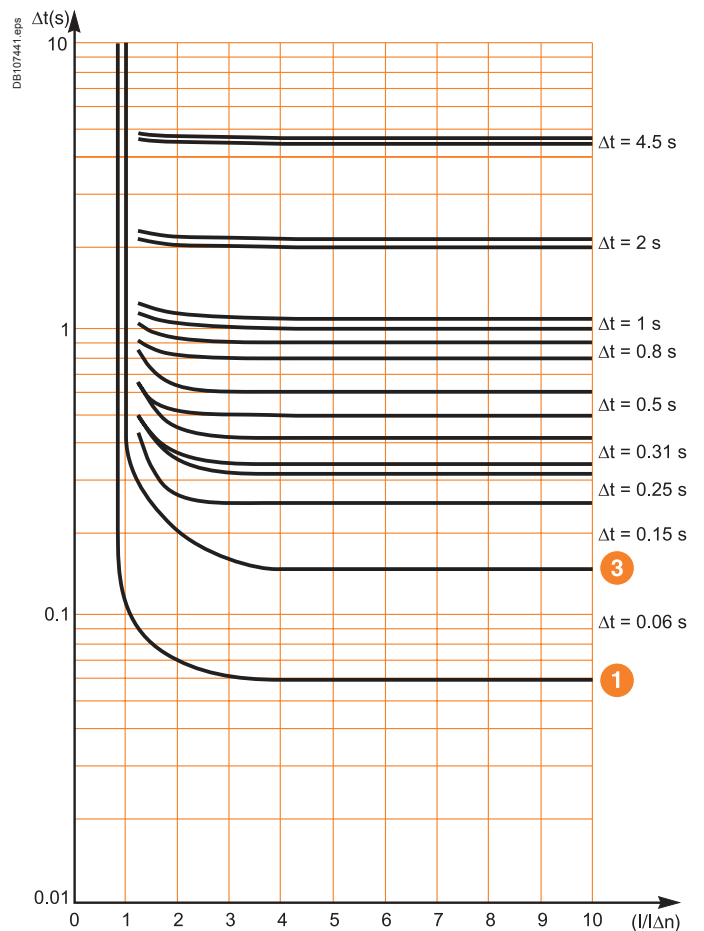

---

<i>Functions and characteristics</i>	A-1
<i>Installation recommendations</i>	B-1
<i>Dimensions and connection</i>	C-1
<i>Wiring diagrams</i>	D-1
<i>Additional characteristics</i>	E-1
<b>Residual-current protection relays</b>	<b>F-2</b>
<b>Residual-current protection relays or monitoring relays</b>	<b>F-4</b>
<b>Toroids and rectangular sensors, communication module, accessories</b>	<b>F-5</b>

## RH10 with local manual fault reset

System to be protected LV ≤ 1000 V

### RH10M

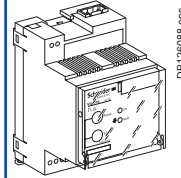

DIN-rail mount.

### RH10P

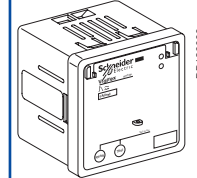

Front-panel mount.

### Sensitivity 0.03 A - instantaneous

Power supply	12 to 24 V AC - 12 to 48 V DC	50/60 Hz	<b>56100</b>	<b>56200</b>
	110 to 130 V AC	50/60 Hz	<b>56120</b>	<b>56220</b>
	220 to 240 V AC	50/60/400 Hz	<b>56130</b>	<b>56230</b>
	380 to 415 V AC	50/60 Hz	<b>56140</b>	<b>56240</b>
	440 to 525 V AC	50/60 Hz	<b>56150</b>	

### Sensitivity 0.05 A - instantaneous

Power supply	110 to 130 V AC	50/60 Hz	<b>56121</b>	
	220 to 240 V AC	50/60/400 Hz	<b>56131</b>	

### Sensitivity 0.1 A - instantaneous

Power supply	12 to 24 V AC - 12 to 48 V DC	50/60 Hz	<b>56102</b>	<b>56202</b>
	110 to 130 V AC	50/60 Hz	<b>56122</b>	<b>56222</b>
	220 to 240 V AC	50/60/400 Hz	<b>56132</b>	<b>56232</b>
	380 to 415 V AC	50/60 Hz	<b>56142</b>	<b>56242</b>

### Sensitivity 0.25 A - instantaneous

Power supply	220 to 240 V AC	50/60/400 Hz	<b>56134</b>	<b>56234</b>
--------------	-----------------	--------------	--------------	--------------

### Sensitivity 0.3 A - instantaneous

Power supply	12 to 24 V AC - 12 to 48 V DC	50/60 Hz	<b>56105</b>	<b>56205</b>
	110 to 130 V AC	50/60 Hz	<b>56125</b>	<b>56225</b>
	220 to 240 V AC	50/60/400 Hz	<b>56135</b>	<b>56235</b>
	380 to 415 V AC	50/60 Hz	<b>56145</b>	<b>56245</b>

### Sensitivity 0.5 A - instantaneous

Power supply	12 to 24 V AC - 12 to 48 V DC	50/60 Hz	<b>56106</b>	<b>56206</b>
	110 to 130 V AC	50/60 Hz	<b>56126</b>	<b>56226</b>
	220 to 240 V AC	50/60/400 Hz	<b>56136</b>	<b>56236</b>
	380 to 415 V AC	50/60 Hz	<b>56146</b>	<b>56246</b>
	440 to 525 V AC	50/60 Hz	<b>56156</b>	

### Sensitivity 1 A - instantaneous

Power supply	12 to 24 V AC - 12 to 48 V DC	50/60 Hz	<b>56107</b>	<b>56207</b>
	110 to 130 V AC	50/60 Hz	<b>56127</b>	<b>56227</b>
	220 to 240 V AC	50/60/400 Hz	<b>56137</b>	<b>56237</b>
	380 to 415 V AC	50/60 Hz	<b>56147</b>	<b>56247</b>
	440 to 525 V AC	50/60 Hz	<b>56157</b>	

## RH21 with local manual fault reset

System to be protected LV ≤ 1000 V

### RH21M

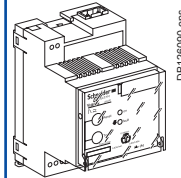

DIN-rail mount.

### RH21P

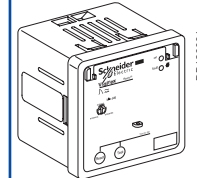

Front-panel mount.

### Sensitivity 0.03 A - instantaneous

### Sensitivity 0.3 A - instantaneous or with 0.06 s time delay

Power supply	12 to 24 V AC - 12 to 48 V DC	50/60 Hz	<b>56160</b>	<b>56260</b>
	110 to 130 V AC	50/60 Hz	<b>56162</b>	<b>56262</b>
	220 to 240 V AC	50/60/400 Hz	<b>56163</b>	<b>56263</b>
	380 to 415 V AC	50/60 Hz	<b>56164</b>	<b>56264</b>
	440 to 525 V AC	50/60 Hz	<b>56165</b>	<b>56265</b>

### RH68 with local manual fault reset

System to be protected LV ≤ 1000 V

#### RH68M

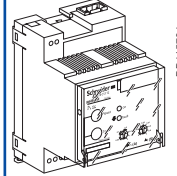

DB415734.eps

DIN-rail mount.

### Sensitivity 0.03 A to 30 A - instantaneous or with 0 to 4.5 s time delay

Power supply 220 to 240 V AC 50/60/400 Hz **56168**

### RH86 with local manual fault reset

System to be protected LV ≤ 1000 V

#### RH86M

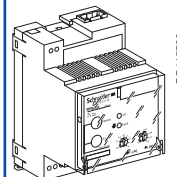

DB415733.eps

DIN-rail mount.

#### RH86P

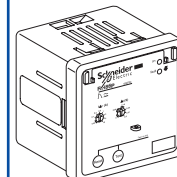

DB415732.eps

Front-panel mount.

### Sensitivity 0.03 A to 30 A - instantaneous or with 0 to 4.5 s time delay

Power supply 220 to 240 V AC 50/60/400 Hz **56500** **56502**

### RH99 with local manual fault reset

System to be protected LV ≤ 1000 V

#### RH99M

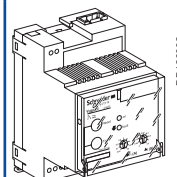

DB126092.eps

DIN-rail mount.

#### RH99P

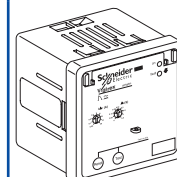

DB126093.eps

Front-panel mount.

### Sensitivity 0.03 A to 30 A - instantaneous or with 0 to 4.5 s time delay

Power supply	12 to 24 V AC - 12 to 48 V DC	50/60 Hz	<b>56170</b>	<b>56270</b>
	110 to 130 V AC	50/60 Hz	<b>56172</b>	<b>56272</b>
	220 to 240 V AC	50/60/400 Hz	<b>56173</b>	<b>56273</b>
	380 to 415 V AC	50/60 Hz	<b>56174</b>	<b>56274</b>
	440 to 525 V AC	50/60 Hz	<b>56175</b>	<b>56275</b>

### RH197 with local manual or automatic fault reset <sup>(1)</sup>

System to be protected LV ≤ 1000 V

#### RH197M

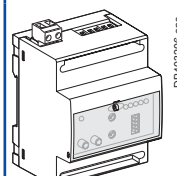

DB403206.eps

DIN-rail mount.

#### RH197P

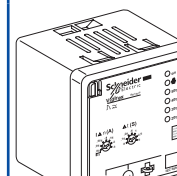

DB126094.eps

Front-panel mount.

### Alarm: 50 % of fault threshold - instantaneous

#### Fault: sensitivity 0.03 A to 30 A - instantaneous or with 0 to 4.5 s time delay

Single-phase power supply	48 V AC - 24 to 130 V DC	50/60 Hz	<b>56515</b>	<b>56505</b>
	110 to 130 V AC <sup>(2)</sup>	50/60 Hz	<b>56516</b>	<b>56506</b>
	220 to 240 V AC <sup>(2)</sup>	50/60/400 Hz	<b>56517</b>	<b>56507</b>
	380 to 415 V AC <sup>(2)</sup>	50/60 Hz	<b>56518</b>	<b>56508</b>

### Alarm: 100 % of fault threshold - instantaneous

#### Fault: sensitivity 0.03 A to 30 A - instantaneous or with 0 to 4.5 s time delay

Single-phase power supply	48 V AC - 24 to 130 V DC	50/60 Hz	<b>56515</b>	<b>56510</b>
	110 to 130 V AC <sup>(2)</sup>	50/60 Hz	<b>56516</b>	<b>56511</b>
	220 to 240 V AC <sup>(2)</sup>	50/60/400 Hz	<b>56517</b>	<b>56512</b>
	380 to 415 V AC <sup>(2)</sup>	50/60 Hz	<b>56518</b>	<b>56513</b>

<sup>(1)</sup> Selected via a switch.

<sup>(2)</sup> RH197M: 110 V, 230 V, 400 V.

## Residual-current protection relays

### RHUs with local manual fault reset

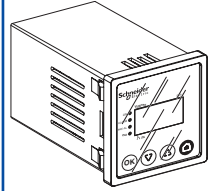
System to be protected	LV ≤ 1000 V		<b>RHUs</b>	
<b>Alarm: sensitivity 0.015 A to 30 A - instantaneous or with 0 to 4.5 s time delay</b>				
<b>Fault: sensitivity 0.03 A to 30 A - instantaneous or with 0 to 4.5 s time delay</b>				
Single-phase power supply	110 to 130 V AC	50/60 Hz		<b>LV481000</b>
	220 to 240 V AC	50/60/400 Hz		<b>LV481001</b>

### RHU with local manual fault reset (communicating)

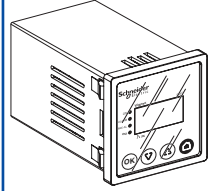
System to be protected	LV ≤ 1000 V		<b>RHU</b>	
<b>Alarm: sensitivity 0.015 A to 30 A - instantaneous or with 0 to 4.5 s time delay</b>				
<b>Fault: sensitivity 0.03 A to 30 A - instantaneous or with 0 to 4.5 s time delay</b>				
Single-phase power supply	110 to 130 V AC	50/60 Hz		<b>LV481002</b>
	220 to 240 V AC	50/60/400 Hz		<b>LV481003</b>

## Monitoring relays

### RH99 with automatic fault reset

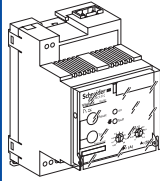
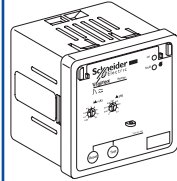
System to be protected	LV ≤ 1000 V		<b>RH99M</b>		<b>RH99P</b>	
			DIN-rail mount.			Front-panel mount.
<b>Sensitivity 0.03 A - instantaneous</b>						
<b>Sensitivity 0.1 A to 30 A - instantaneous or with 0 s to 4.5 s time delay</b>						
Power supply	12 to 24 V AC - 12 to 48 V DC	50/60 Hz	<b>56190</b>		<b>56290</b>	
	110 to 130 V AC	50/60 Hz	<b>56192</b>		<b>56292</b>	
	220 to 240 V AC	50/60/400 Hz	<b>56193</b>		<b>56293</b>	
	380 to 415 V AC	50/60 Hz	<b>56194</b>		<b>56294</b>	
	440 to 525 V AC	50/60 Hz	<b>56195</b>			

### RMH and multiplexer RM12T (communicating)

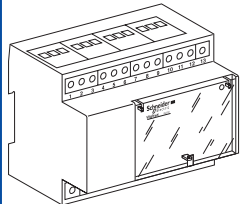
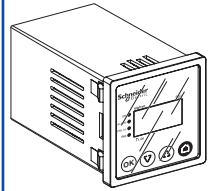
System to be monitored	LV ≤ 1000 V		<b>RM12T</b>		<b>RMH</b>	
			DIN-rail mount.			Front-panel mount.
<b>Pre-Alarm: sensitivity 0.015 A to 30 A - instantaneous or with 0 to 5 s time delay</b>						
<b>Alarm: sensitivity 0.03 A to 30 A - instantaneous or with 0 to 5 s time delay</b>						
Single-phase power supply	220 to 240 V AC	50/60/400 Hz	<b>28566</b>		<b>LV481004</b>	

# Toroids and rectangular sensors, communication module, accessories

## Sensors

### Closed toroids, A-type

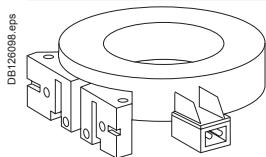

Type	le (A) rated operational current	Inside diameter (mm)	
TA30	65	30	50437
PA50	85	50	50438
IA80	160	80	50439
MA120	250	120	50440
SA200	400	200	50441
GA300	630	300	50442

### Accessory for closed toroids



Magnetic ring	For TA30 toroid	56055
	For PA50 toroid	56056
	For IA80 toroid	56057
	For MA120 toroid	56058

### Split toroids, TOA-type

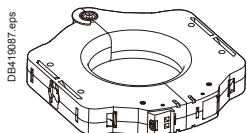

Type	le (A) rated operational current	Inside diameter (mm)	
TOA80	160	80	50420
TOA120	250	120	50421

### Rectangular sensors

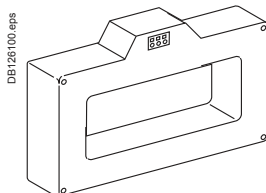

Inside dimensions (mm)	le (A)		
L1	1600	280 x 115	50485
L2	3200	470 x 160	50486

## Accessories



1 screws bag for RH●●M and P	56060
------------------------------	-------

**Note:** sensor-relay link: twisted cable not supplied (see "Installation and connection" chapter).





## Schneider Electric Industries SAS

35, rue Joseph Monier  
CS 30323  
92506 Rueil Malmaison Cedex  
France

RCS Nanterre 954 503 439  
Capital social 896 313 776 €  
[www.schneider-electric.com](http://www.schneider-electric.com)

*As standards, specifications and designs change from time to time, please ask for confirmation of the information given in this publication.*

Publication: Schneider Electric Industries SAS

