

# Power availability in Data Center applications

## Dongguan Telecom



### The customer: **Dongguan Telecom**



A subsidiary of China Telecom – the largest telecommunications operator in China – Dongguan Telecom's 324 million RMB operation is a leading national internet and mobile network service provider.

The development of their Data Center facility includes a hard-working electrical infrastructure to ensure that the operation maintains peak performance at all times.

Proven within Data Center applications, Socomec's automatic transfer switches offer the ultimate protection for an organisation's critical assets, infrastructure and people - and operate in some of the most demanding environments around the world.

# The project

In partnership with Socomec and distributor, Kingroad, Dongguan's Data Center project represents a significant investment of over 1 million RMB and is a high profile development that started life in 2015.

With construction work ongoing through 2016, this super-scale Data Center will tower six floors high, with a further two floors below ground level, serving the entire Dongguan Telecom estate.



# The requirements

The key requirement for this Data Center facility was to **ensure transfer between a 2000 kVA transformer and a 2000 kVA genset.**

Guaranteeing mains incoming power across the whole infrastructure, 4000 4P 380 VAC, **the power supply interruption to the load is minimal during transfer.**

Ongoing safety and performance - and **guaranteed business continuity** - are vital, as is the associated protection of critical assets, infrastructure and people.

Furthermore, **easy and efficient ongoing maintenance** is critical.

Comprehensive technical training will ensure that the system's performance is optimised throughout the product's lifecycle.

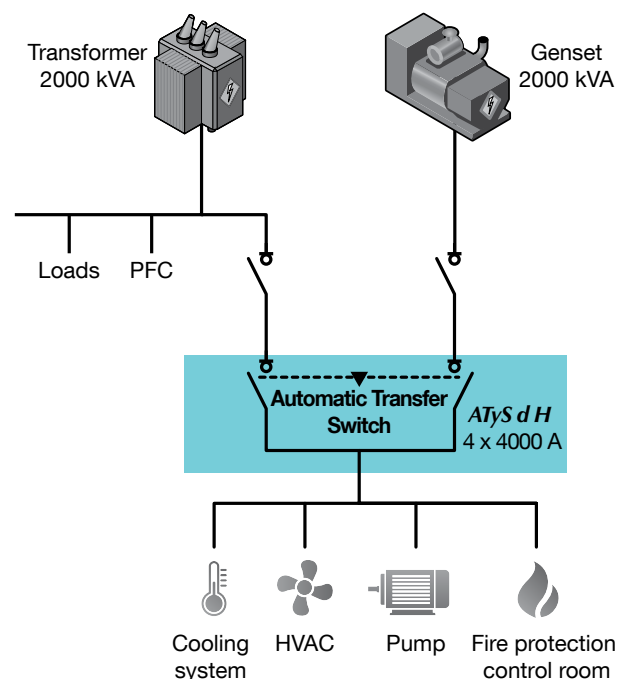

# The solution

ATyS d H Transfer Switching Equipment from 4000 to 6300 A.

**Eight units of 4000 A 4P have been supplied for this project.** Power availability is safeguarded when using integrated and safe transfer switching equipment. Socomec's ATyS d H transfer switching equipment has been designed for use in power systems for the safe transfer of a load supply between a normal and alternative source.

The changeover takes place in open transition and with minimum supply interruption during transfer, ensuring full compliance with IEC 60947-6-1 and GB 14048-11.

The ATyS d H is a remotely operated Transfer Switching Equipment (RTSE) that can be easily used in conjunction with an ATS controller – C20/30 or C40, depending on the application – to provide automatic functionality.

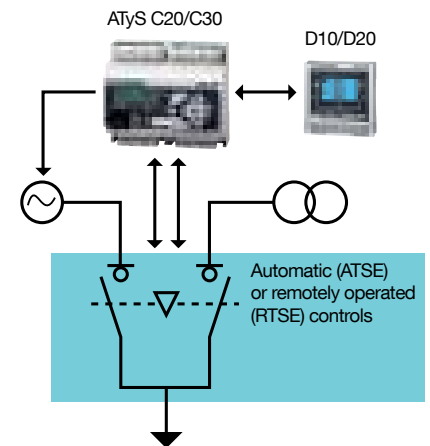

# The advantages

## High performance switching

Socomec's ATyS d H is a remote three-phase transfer switch with 3 and 4 poles and integrated dual power supply. Engineered for low voltage high power applications it has been designed for applications that demand high performance and rapid, reliable switching. Offering high withstand short circuit current ratings of 143 kA  $I_{cm}$  (making) and 65 kA for 0.1 second  $I_{cw}$  (withstand), the performance in terms of load switching capacity is AC33iB (6xIn cos  $\phi$  0.5) without derating.

## Easy & fast integration

The multiple mounting options mean that integration is easy, whether into standard enclosures or custom-designed structures. Two switches are mounted one above the other, with accessible power connections located at the rear. The installation time can be reduced even further as the load side is connected within the product – eliminating the need for external bridging bars.

## Safe on load transfer I-0-II

The ATyS d H includes two mechanically interlocked switches to ensure fast switching whilst providing a neutral (Off - 0) position. This ensures that the main and alternative power supplies do not overlap. The 0 position can also be used for safe maintenance of the installation, providing isolation between both sources and the load – a vitally important factor in this specific application.

# Key success factors

As a recognised leader in high performance switching systems, the ability to deliver **optimised safety and guaranteed performance** were key factors in the selection of Socomec as a partner in this prestigious project.

What were the deciding factors in the selection of Socomec's solutions?

- Socomec's ability to provide **specialist support** throughout the project – as well as providing a vision for the future.
- Socomec's delivery of **expert training** prior to installation and commissioning, resulting in the simplification of ongoing maintenance.
- Guaranteed **business continuity and safe product maintenance** associated with the 0 position.
- Socomec's investment in the creation of strong relationships and anticipation of challenges and needs.
- Best in class performance combined with a compelling commercial product and service package.

## → Focus on

**Kerry Gu,**  
Region Marketing Leader



“As a global integrated power specialist, Socomec delivers the most robust, reliable and efficient energy performance solutions for mission critical applications.

We invest heavily in Research and Development to ensure that we design and manufacture products that exceed the appropriate standards – as well as exceeding our customers' expectations.

Furthermore, we understand that our customers need to maintain control of their operating costs.

Our expert engineering teams provide exemplary technical support throughout the entire process. From design to installation, commissioning and on-site maintenance, we ensure that the system operates at peak performance – today and tomorrow.”

### Key figures:

**Investment:** over 1 million RMB

**Size:** 8 floors high tower

**Project duration:** 1 year

**Number of products:**

8 ATyS d H installed

### HEAD OFFICE

#### SOCOMEK GROUP

SAS SOCOMEK capital 10 686 000 €  
R.C.S. Strasbourg B 548 500 149  
B.P. 60010 - 1, rue de Westhouse  
F-67235 Benfeld Cedex - FRANCE

### INTERNATIONAL SALES DEPARTMENT

#### SOCOMEK

1, rue de Westhouse - B.P. 60010  
F - 67235 Benfeld Cedex - FRANCE  
Tel. +33 (0)3 88 57 41 41  
Fax +33 (0)3 88 74 08 00  
info.scp.isd@socomec.com

### YOUR DISTRIBUTOR / PARTNER

[www.socomec.com](http://www.socomec.com)

your energy  
our expertise

