

Power availability in building application

Fuzhou Lijia International Commercial Center



The customer: Linca Industrial Group



Established in 1992, Hong Kong based multi-million RMB real estate development group - Linca Industrial Group Co. Ltd - invests in the construction of infrastructure throughout Asia, the US and Australia. With interests in sustainable urban development across a number of diverse sectors, the group's 3000 employees and 100 member organisations are active in transportation, mining, energy, forestry, medicine, logistics and hospitality.

A progressive and hard-working organisation, Linca Industrial Group's landmark projects deliver measurable change, transforming the landscape of urban areas.

The group's work positively impacts communities and cities, whilst raising the profile of important renewal and renovation work.

Developments are diverse, from a residential complex including cottages and high-rise buildings on the Zhongtian Gold Coast, to the creation of a shopping mall complex with its own hotel at Fuging Linca Center. Investments also include the Nantong Tianze International Trade City - China's largest trading area for wine and medicine.

The deployment of Socomec's products and services within such a prestigious and important development is testament to their efficacy and performance.

The project

The 87 acre site is located south of Third Ring of Fuzhou in Fujian province, and is home to the largest distribution centre in the West-Straits Economic Area. Purchased in 2015/16, the global investment in this innovative project is over 15 billion RMB.

A key project within Fujian province, China, the Fuzhou Lijia International Commercial Center is a 100 billion RMB contemporary development by Linca Industrial Group. The promotion of trade and international business relationships extends across a range of products including gold, jewellery, clothing and footwear, leather goods, bedding, sports equipment and cosmetics.

This 3 million square metre commercial and shopping complex boasts a 4D theatre and food court as well as a logistics centre, office buildings and other supporting infrastructure and facilities including 10,000 parking spaces. For the ultimate shopping experience, visitors can even stay in the 5* hotel – and for those who want their own slice of real estate, exclusive apartments are available to buy on the prestigious site.



The requirements

The main objective of this high profile project was to **enable automatic transfer switching between two sources (normal – emergency) and to ensure power availability throughout the building.**

Ensuring the continuity of power supply within a public venue such as Fuzhou Lijia International Commercial Center presents a range of challenges – which Socomec addressed with the following solutions:

- Protection of critical assets thanks to highly controlled switching
- Minimal downtime (contact transfer time of 150 ms)
- Fast and easy integration to meet the project delivery deadline
- Compatibility with building management and fire monitoring systems

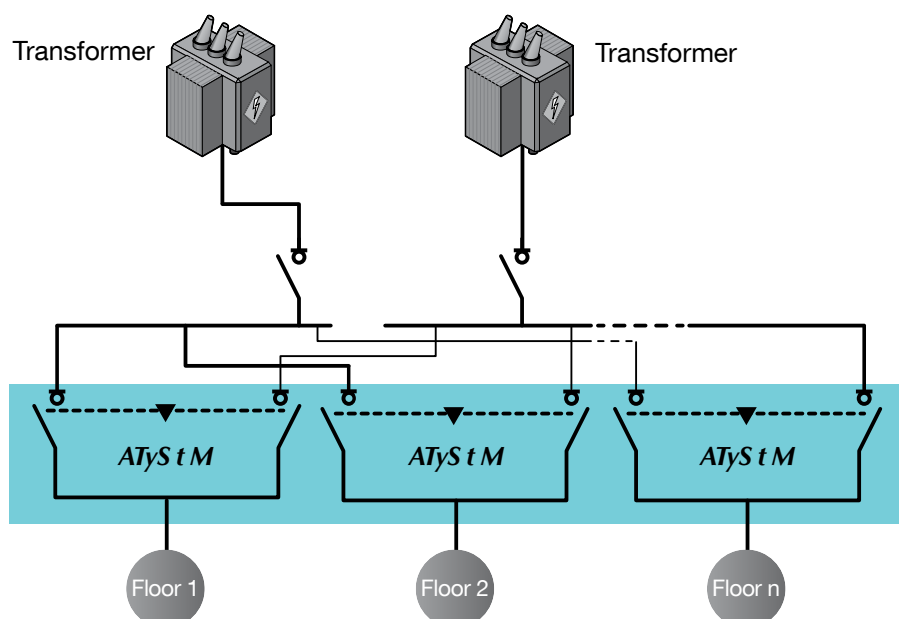

The solution

In partnership with key distributor Tengsheng, the integrated power solutions manufacturer, Socomec, has provided **more than 3000 ATyS t M** automatic transfer switches for the Fuzhou Lijia International Commercial Center project.

Socomec's ATyS t M are 4 pole, three-phase, modular automatic transfer switches with positive break indication. This automatic switching solution guarantees the critical power supply, optimising both safety and performance.

The equipment monitors the supply to a critical system and – in the event of failure or instability – safely manages the transfer to an alternate source. ATyS M are ideal for use in low voltage power supply systems, where a brief interruption of the load supply is acceptable during transfer.

Based on Socomec's proven load-break switching technology, ATyS M provide a robust and modular solution to safety and supply availability requirements.

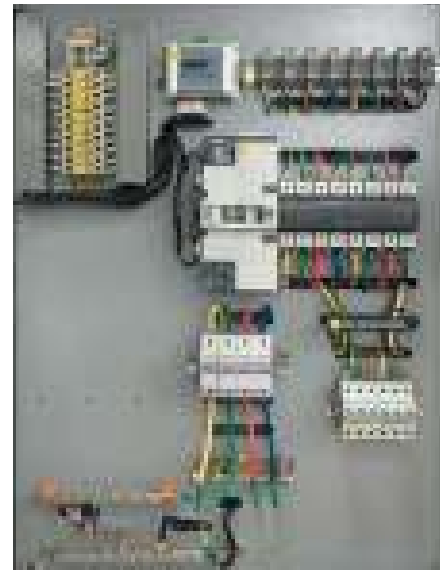

ATyS t M 4 x 125 A

The advantages



ATyS-TM_000_LB

Maximum safety

Safety is optimised via both electrical and mechanical interlocking. A manual operating handle is included as standard as an additional safety feature, for rapid response emergency access at all times. Immunity to voltage fluctuations is as a result of stable positions - and that the power supply is only required during switching. The ATyS demonstrates excellent dynamic withstand for improved safety when closing on a short-circuit. Electromagnetic actuator technology with rotary self-cleaning contacts guarantees extremely low electrical blackout time.

Fully integrated solution

Supplied as a complete, plug and play manufacturer-certified, compact unit that is robust, reliable and simple to install. The ATyS enables new and refurbished critical buildings and facilities to conform to IEC 60947-6-1: the international standard governing transfer switching equipment, as well as to GB 14048-11: the equivalent Chinese standard. Easy to order; one single part number covers the complete solution.

Easy to install

Quick and simple to commission: nominal voltage and frequency are configured automatically.

With an integrated controller for use with Mains/Mains applications, the labour intensity of commissioning is reduced. Programming is via one potentiometer and dip switches – using just a screwdriver. Furthermore, secure programming is provided by sealable cover, preventing access to the configuration panel and mitigating against tampering. Coil-based technology speeds up the operation with a contact transfer time of 150ms.

Key success factors

The combination of **optimised safety and guaranteed performance** was critical in the selection of the Socomec ATyS.

Specific product features were vitally important to ensure the total security and operational requirements of this project:

- Manual transfer on load, available as emergency function
- Contact transfer time of less than 500 ms
- Product padlocking possible in the 0 position for safe maintenance
- Padlocking configurable in any position (I, 0 or II)

In addition to the safety and performance of the core product, service played a deciding role in the choice of project partner.

The ability of the Socomec team to provide expert local support from the initial specification right through to the commissioning of the electrical installation was a key factor in the success of this project.

→ Focus on

Kevin Wang,
Product Support &
Training Officer, Socomec



The combined impact of a high performance product from a European manufacturer – plus local, 24 hour on-site servicing and a 3 year warranty from our distribution partner – meant that we were able to provide a compelling package for this exciting project. With significant investment in our global development and production facilities, we are a recognized leader in high performance switching systems.

We offer a complete range of load-break switches and can individually engineer solutions for very specific requirements. Furthermore, the fact that we have identified and built a worldwide network of expert engineering and technical resource means that we are able to support the equipment throughout the product lifecycle.

Fuzhou Lijia International Commercial Center key figures:
Investment: 100 billion RMB
Size: 3 million square metre commercial and shopping complex
Project duration: 2 years
Number of products:
3000 ATyS t M installed

HEAD OFFICE

SOCOMEK GROUP

SAS SOCOMEK capital 10 686 000 €
R.C.S. Strasbourg B 548 500 149
B.P. 60010 - 1, rue de Westhouse
F-67235 Benfeld Cedex - FRANCE

INTERNATIONAL SALES DEPARTMENT

SOCOMEK

1, rue de Westhouse - B.P. 60010
F - 67235 Benfeld Cedex - FRANCE
Tel. +33 (0)3 88 57 41 41
Fax +33 (0)3 88 74 08 00
info.scp.isd@socomec.com

YOUR DISTRIBUTOR / PARTNER

www.socomec.com

your energy
our expertise

