



A HANDBOOK ON
EARTHING
SOLUTIONS

Table of Contents

1. Earthing.....	2
1.1 What is Earthing?.....	3
1.2 Equipment Earthing.....	5
1.3 Earthed or Unearthed System.....	7
1.4 Types of Earth Electrode and its Resistance.....	9
1.5 Comparison of Plate and Pipe Earth Electrodes.....	13
1.6 Impact of Soil Resistivity on Solid Grounding.....	15
1.7 Parallel Connection of Earth Electrode.....	17
1.8 Selection of Metal for Earth Electrode.....	21
1.9 Why Copper is more preferable for Earthing?.....	23
1.10 Sizing of Earth Conductor.....	25
1.11 Current Carrying Capacity of Different Materials.....	27
1.12 UL 467 - Grounding and Bonding Equipment.....	30
1.13 Requirements and Testing of Earthing Components.....	33
1.14 Earth Enhancing Compound.....	35
1.15 Requirement and Testing of Earth Enhancing Compound.....	38
2. Maintenance and Measurements.....	43
2.1 Maintenance of Earthing.....	44
2.2 Measurement of Soil Resistivity.....	49
2.3 Measurement of Earth Electrode Resistance.....	52
3. Applications.....	56
3.1 Earthing In Substation.....	57
3.2 Earthing Associated with Overhead Power Lines.....	61
3.3 Earthing for Industrial Protection.....	64
3.4 Earthing of Conductor for Safe Working.....	66
3.5 Earthing Recommendations for Hazardous Area.....	69
3.6 Earthing in Mines and Quarries.....	71
3.7 Earthing System for Medical Establishments.....	73
3.8 Earthing for External Lightning Protection.....	75
3.9 Foundation Earthing.....	78
3.10 Earthing Recommendations for Telecommunication System.....	80

1. Earthing

1.1 What is Earthing?

What is Earthing?

Earthing is the process of connecting the non-current carrying metal parts of an equipment and current carrying part of an electrical system to the earth. The non-current carrying parts are connected to earth for ensuring the safety of the operating person and the current carrying parts are connected to earth to keep the potential within the tolerable limit and to isolate the system during the fault conditions. The ultimate aim of earthing is to ensure the safety of the operator and proper operation of the equipment.

IS3043:2018 Code of Practice for Earthing suggests that the term “Earthing” and “Grounding” are synonyms to each other and both are same.

IS3043 explains about two types of earthing and are as follows.

- Equipment Earthing
- System Earthing

The equipment earthing is defined as the process of connecting the non-current carrying metal parts of an equipment to the earth.

System earthing shall be defined as the process of connecting the current carrying part of an electrical system to the earth.

There are three main components of an earthing arrangement.

1. Earth Electrode
2. Earth Enhancing Compound
3. Terminal Connection

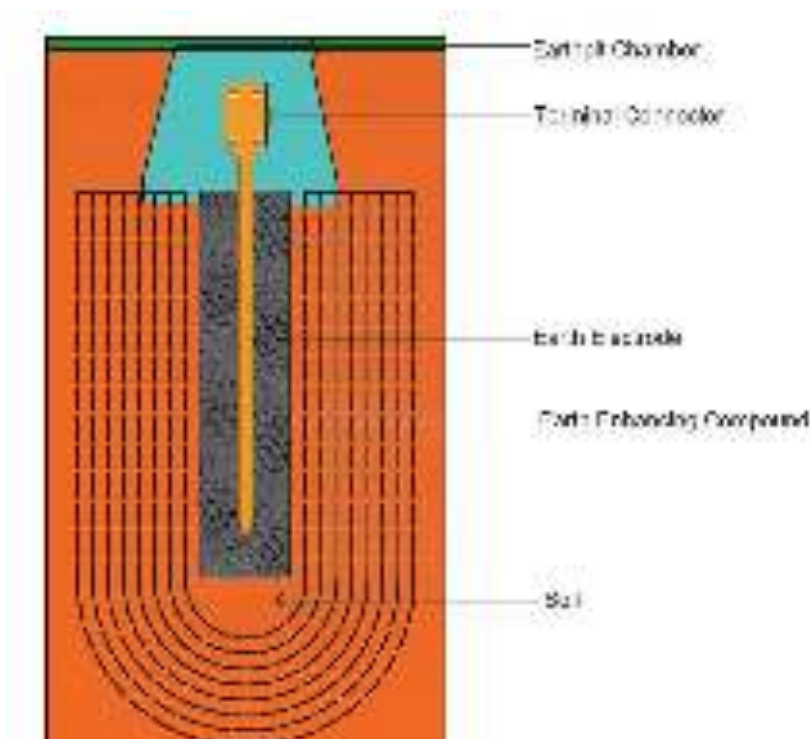

Figure 1. Components of earthing arrangement

IS 3043 suggests that the earth electrodes of the following configurations shall be used for earthing.

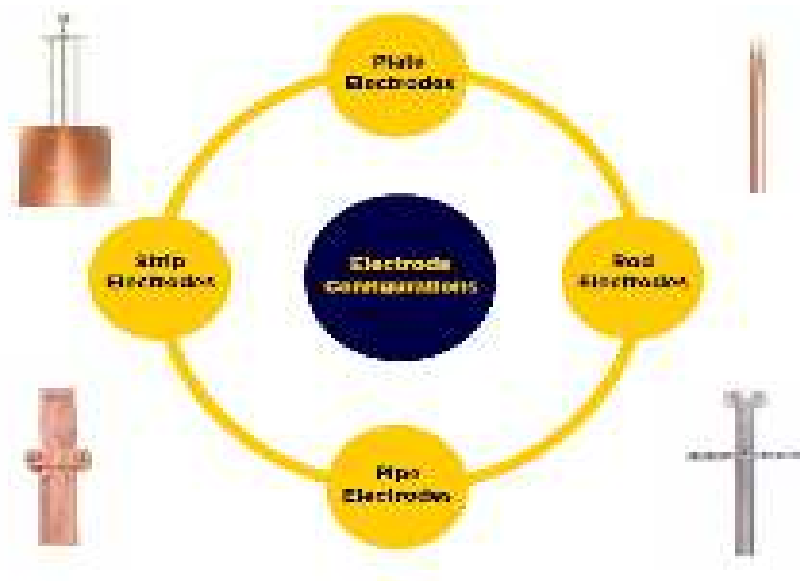

Figure 2. Earth electrode configurations

Earth Electrode Resistance:

The property of each material to oppose the flow of current is termed as electrical resistance. The electrical resistance can be divided into two types as follows.

- Ohmic resistance
- Electrolytic resistance

Ohmic resistance:

The Ohmic resistance is the resistance offered by the material to the current while flowing from one end of the material to another end of the same material. The ohmic resistance value depends on the following factors.

- Resistivity of the material,
- Length and
- Cross sectional area

Each material has its own resistivity and hence the resistance of different materials having same length and cross-sectional area won't be the same.

Electrolytic resistance:

The Electrolytic resistance is the resistance offered to the current while flowing from one electrode to another electrode in any conductive medium (electrolyte). The resistance offered by the electrolyte will be predominant and the resistance of the electrodes will be very negligible.

As mentioned by IS 3043, the conduction of current in an earthing system is electrolytic in nature. In earthing, the soil surrounding the electrode acts as the electrolyte and hence the earth electrode resistance mainly depends on the resistivity of the soil and not on the resistance of the earth electrode.

1.2 Equipment Earthing

Introduction:

During abnormal condition, discharging the rapid current to earth with the help of dedicated low resistance path is called Earthing.

The equipment earthing is defined as the process of connecting the non-current carrying metal parts of an equipment like metal frame and structure to the earth. The purpose of the equipment earthing is to ensure the safety of the operating person.

If an energized conductor touches the frame unintentionally, the fault current will flow into the metal part. These short circuit current will flow through the earthing conductor to earth before it become dangerous to personnel. IS3043 explains about the equipment earthing and the details are as follows.

Objective of Equipment Earthing:

The basic objectives of equipment earthing are,

- To ensure the protection of the person from electric shock,
- To provide low resistance path to the fault current by using conductors having sufficient current carrying capability without creating a fire or explosive hazard to building or contents,
- To ensure the better performance of the electrical system.

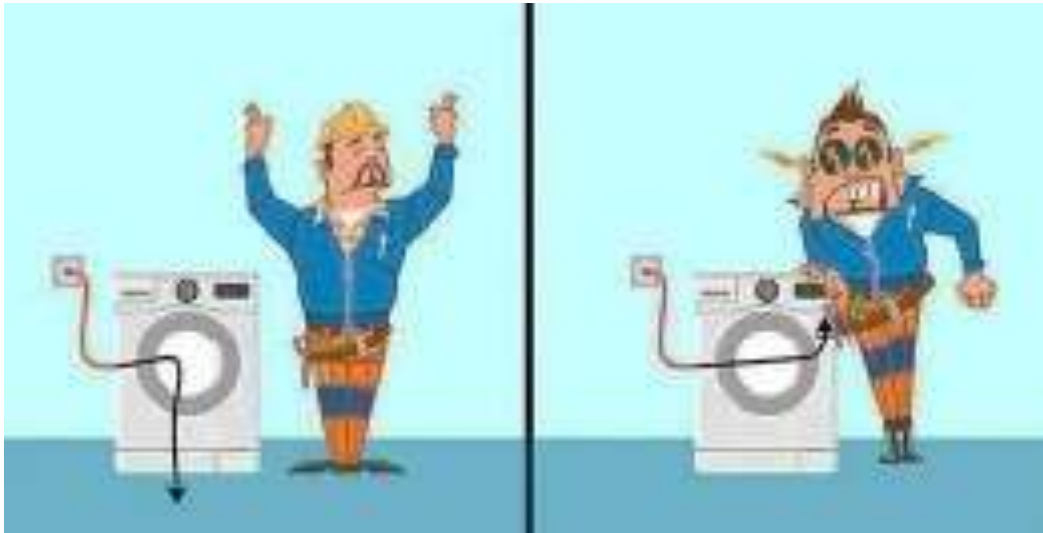

Figure 3. Equipment earthing

Voltage Exposure:

When the live conductor (live wire) has an unintentionally contact with non-current carrying conductors like metal frame, enclosure etc., then the metal frame or enclosure energized to the same voltage level of the live conductor.

During these kinds of abnormal situations, a person touching the metal frame or enclosure may result in severe accident. To avoid this dangerous shock hazard, the metallic frame should be

grounded through low impedance path. By doing so the fault current will be diverted to earth through the least resistance path.

Avoidance of Thermal distress:

During the fault condition the magnitude of current will be much higher and hence the heat generated by the current while flowing through the earthing conductor will also be higher. This excessive heat may cause fire at some condition. So, the size of earthing conductor should be selected in such a way that it is not only capable of withstanding the fault current for a specified time period without any physical damages but also without much increase in the temperature.

If the resistance of the grounding circuit is higher, it may limit the magnitude of fault current and the protecting system may fail to detect the fault. Hence, the total impedance of the fault circuit including earthing conductor should permit the required current for the proper operation of the protective system.

Preservation of System Performance:

The resistance offered by the earthing conductor should be as low as possible. If the resistance of the earthing circuit is higher it will limit the fault current which may result in the maloperation of the protective devices during fault condition.

Classification of Equipment:

IS3043 classifies the equipment into four types based on protection measures against electric shock. The four types are as follows.

	Class 0	Class I	Class II	Class III
Principal Characteristics of Equipment	No means of protective earthing	Protective earthing means provided	Additional insulation and no means for protective earthing	Designed for supply at safety extra low voltage
Precautions for safety	Earth free environment	Connection to the protective earthing	None necessary	Connection to safety extra low voltage

Table 1. Characteristics and precaution of different classes of equipment

1.3 Earthed or Unearthed System

Introduction:

Earthing is the process of connecting the current carrying and non-current carrying metal parts of an electrical system to dissipate the currents to the ground. Even though earthed system has so many advantages, the unearthed system is preferred for safety-critical applications, such as intensive care units, where a failure of the power supply would have disastrous consequences.

Whether a system is grounded or not, protection of personnel and property from hazards require thorough grounding of equipment and structures. Safety of operating person and equipment is one of the main objectives of earthing, IS 3043 explains about the factors influencing the choice of earthed or unearthed system and the details are as follows.

Earthed or Unearthed System:

IS 3043 explains about the following factors for comparing the earthed and unearthed systems. They are,

1. Service Continuity
2. Multiple Faults to Ground
3. Arcing Fault Burn downs
4. Location of Faults
5. Safety
6. Abnormal Voltage Hazards
7. Cost

Some of the factors are explained below.

Service Continuity:

- Protection against electric shock during any fault can be achieved by automatic disconnection of supply during the fault conditions. In an earthed system, the circuit protective devices will remove the faulty circuit from the system.
- Unearthed systems are used in specific industries where the continuity of service is very important.

Multiple Faults to Ground:

- When a ground fault occurs on an earthed system, the circuit protective devices will remove the faulty circuit from the system and multiple ground faults are very rarely experienced.
- In an unearthed system, a ground fault on one phase does not cause a service interruption. But the occurrence of a second ground fault on a different phase before the first fault is cleared will result in interruption of service. If a ground fault remains for a longer period, then the chances for the second fault occurring in another phase is very high. Hence an organized maintenance programme is extremely important in an unearthed system for locating and removing the faults immediately after detection.

Arcing Fault Burn downs:

- In an unearthed system, an arcing fault becomes established between two or more phase conductors and between phase and ground in a solidly earthed-neutral system.
- The arcing fault current levels are very low that phase overcurrent protective devices do not operate to remove the fault quickly. Arcing ground faults can be extremely destructive if they are not detected and cleared properly.
- Protection against the arcing fault current can be achieved by fast and sensitive detection of faults and interrupting the fault within 10-20 cycles.
- In solidly earthed neutral systems, an arcing fault would produce a current in the ground path and by sensing the current we can detect and trip the circuit against phase-to-ground arcing fault breakdowns.

Location of Faults:

- In an earthed system, an accidental ground fault can be both indicated and the service to accidentally grounded circuit will be automatically interrupted by the protection system.
- In an unearthed system, a ground fault does not open the circuit. Hence some additional devices for detecting the presence of a ground fault requires to be installed. Insulation Fault Location Systems can be used to detect the faults in an unearthed system.

Abnormal Voltage Hazards:

- The failure of equipment due to over voltages occurs more frequently in an unearthed system than in the earthed system.
- A fault on one phase of an unearthed or impedance grounded system will result in an increased voltage of about 1.73 times the normal voltage on the insulation of ungrounded phases in a 3-phase system.
- The sustained over-voltages on the unearthed system may not immediately cause failure of insulation but may tend to reduce the life of the insulation.

Some of the more common sources of over-voltages on a power system are the following:

- Lightning,
- Switching surges,
- Static,
- Line-to-ground fault,
- Resonant conditions, and
- Re-striking ground faults.

Among these sources lightning is a natural source of over voltage.

1.4 Types of Earth Electrode and its Resistance

Introduction:

The main purpose of an earth electrode is to dissipate the fault current to the earth without any damages and much increase in the temperature. Hence the earth electrode should have the capacity to withstand the currents without any physical damages. Since the earth electrodes have direct contact with the soil, it should have good corrosion resistance property.

IS3043:2018 specifies about four different configurations of earth electrodes and are as follows.

- 1) Plate Earth Electrode
- 2) Pipe Earth Electrode
- 3) Rod Earth Electrode
- 4) Strip or Conductor Earth Electrode

Plate Earth Electrodes:

IS3043:2018 under clause 14.2.1 provides the formula for calculating the resistance of the plate electrode to earth.

$$R = \frac{\rho}{4} \sqrt{\frac{\pi}{A}} \text{ ohms}$$

Where,

ρ = resistivity of the soil in $\Omega.m$.

A = surface area of both sides of plate in m^2 .

From the above formula we can conclude that the earth resistance value of plate electrode depends on the resistivity of the soil and dimensions of the plate electrode alone and it does not depend on the ohmic resistance of the plate.

The dimensions of the plate electrode shall be at least (600X600)mm and the thickness varies based on the corrosion resistance property of the material used.

The thickness of different materials for being used as plate earth electrode as specified by IS3043 are as follows,

S.No	Material	Plate dimension	Thickness
1	Cast Iron	600X600mm	12mm
2	GI or steel	600X600mm	6.3mm
3	Copper	600X600mm	3.15mm

Table 2. Thickness of different materials of plate electrodes

Since the earth electrodes have direct contact with the soil, the corrosion resistance property of the material plays a major role in selecting the material of the earth electrode for specific application.

IS 3043 : 2018 under clause 14.3- Selection of metals for earth electrodes, explained about the corrosion rates of different materials buried in different soil conditions. The details are as follows.

Sample dimension: 150X25X3mm

The average loss in weight of specimens of different materials buried on different soil conditions is listed below.

Cast Iron – 2.2% per year

GI – 0.5% per year

Copper - 0.2% per year

The corrosion rate of cast iron material is higher than that of copper and GI and hence if we go for cast iron material then the thickness of cast iron should be greater.

Pipe or Rod Earth Electrodes:

IS3043 under clause 14.2.2 provides the formula for calculating the resistance of the pipe or rod electrode to earth.

$$R = \frac{100\rho}{2\pi l} \log_e \left(\frac{2l}{d} \right) \text{ ohms}$$

Where,

ρ = resistivity of the soil in $\Omega.m$.

l = length of the pipe or rod in cm.

d = diameter of the pipe or rod in cm.

From the above formula we can conclude that the earth resistance value of a pipe or rod electrode depends on the resistivity of the soil and dimensions of the pipe or rod electrode alone and it does not depend on the ohmic resistance of the electrode.

Based on the above equation, the resistance value changes with change in diameter of the pipe or rod and length of the pipe or rod. The variation of earth resistance values with respect to the length on pipes of diameter 13mm, 25mm and 100mm on soil of resistivity 100 $\Omega.m$ is plotted below.

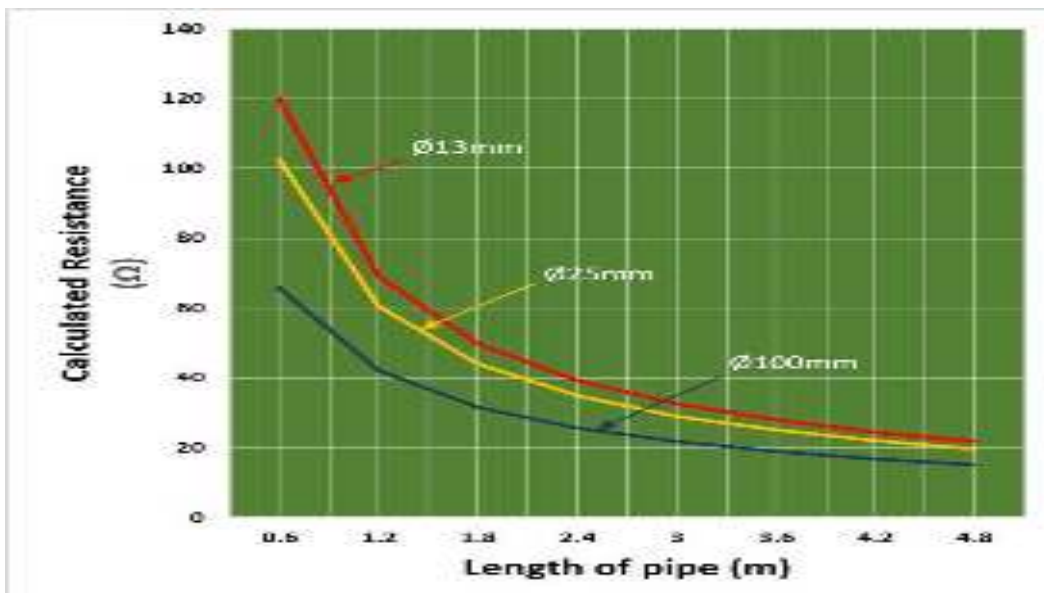

Figure 4. Change in resistance with respect to length of pipe

From the above graph, we can conclude that increasing the length of the electrode has more impact on the earth electrode resistance than increasing the diameter of the pipe electrode.

Strip or Conductor Earth Electrodes:

IS3043 under clause 14.2.1 provides the formula for calculating the resistance of the strip or conductor electrode to earth.

$$R = \frac{100\rho}{2\pi l} \log_e \left(\frac{4l}{d} \right) \text{ ohms}$$

Where,

ρ = resistivity of the soil in $\Omega.m$.

l = length of the strip in cm.

d = width of the strip or twice the diameter of conductor in cm.

From the above formula we can conclude that the earth resistance value of electrode in the form of strip or conductor depends on the resistivity of the soil and dimensions of the strip or conductor alone and it does not depend on the resistance of the electrode.

If we want to reduce the earth electrode resistance values, then multiple earth electrodes shall be connected in parallel based on the target resistance values to be achieved. For Example, as per IS/IEC62305 part 3, the resistance value of the earth termination system should be lesser than 10 ohms. Based on the soil resistivity at the particular location and the target resistance value to be achieved, the number of earth electrodes in parallel connection varies.

Dissipation of Currents:

The Current dissipation from an electrode is assumed to be in the form of concentric circles with the potential decreases gradually away from the electrode. The highest voltage will be observed in the portions adjacent to earth electrode.

The greater part of the fall in potential occurs in the soil within a few feet of the electrode surface, since it is here that the current density is highest. To obtain a low overall resistance the current density should be as low as possible in the medium adjacent to the electrode, which should be so designed as to cause the current density to decrease rapidly with distance from the electrode.

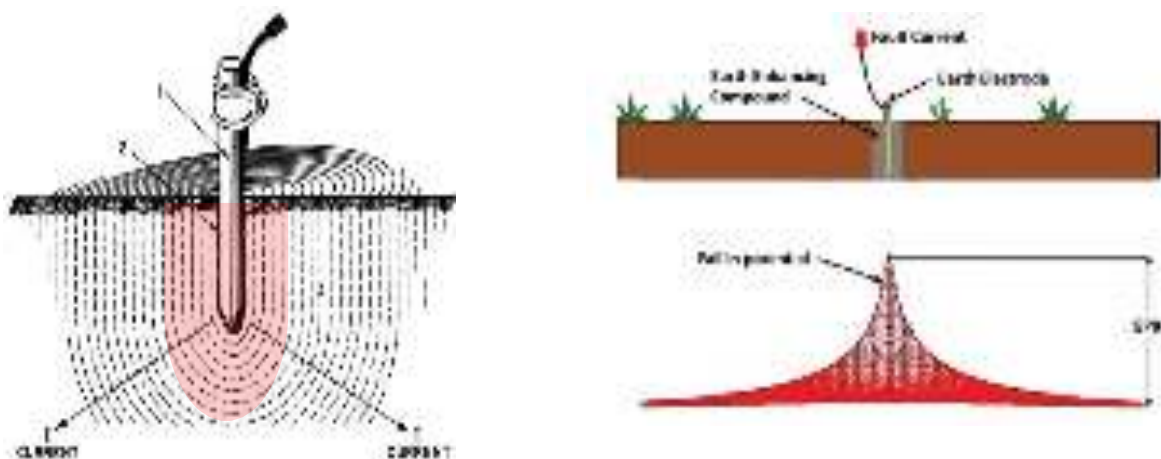

Figure 5. Dissipation of current from earth electrode

Earth Resistance Value:

The variation of dissipation of current from earth electrodes of different dimensions are shown below. The first circle near the electrode will be at very high potential and the potential of circles reduces gradually as we move away from the electrode.

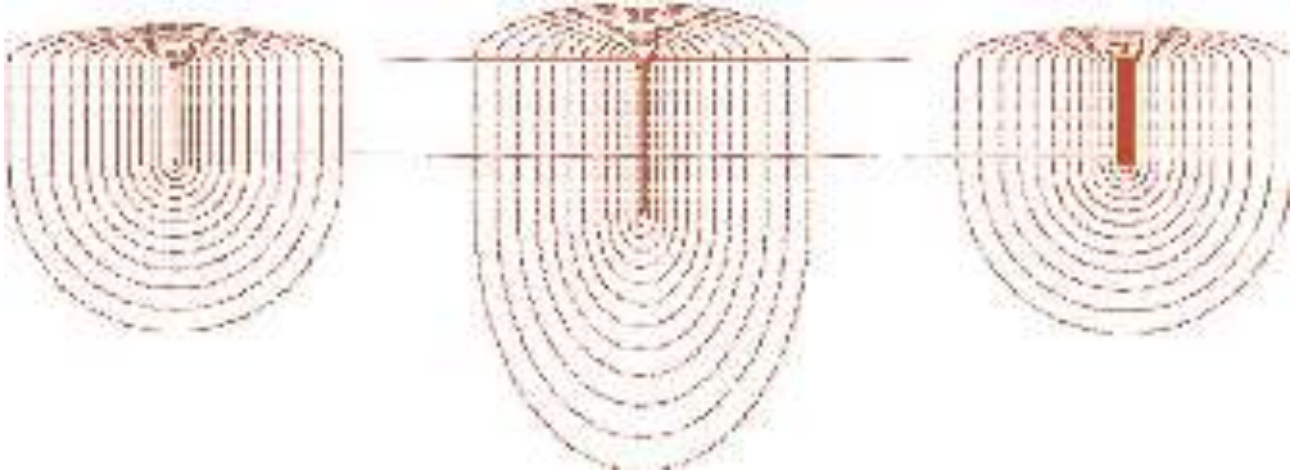

Figure 6. Dissipation of current from electrodes of different dimensions

From the above image we can conclude that, if the diameter of the ground rod is increased, this offers very little change in the area of the hemispherical shells and hence little changes in the resistance. But if the length of the electrode is increased, there will be a considerable reduction in the resistance value.

1.5 Comparison of Plate and Pipe Earth Electrodes

Introduction:

IS 3043 states that If we consider either pipe electrode or plate electrode, the electrode having higher surface area will have the lower resistance value. But if we compare the plate electrode with pipe electrode, this statement is not valid. Even though the plate electrode has equal surface area as that of pipe electrode, it offers high resistance values. Let us discuss about the resistance values of pipe and plate earth electrodes.

Comparison of Plate & Pipe Earth Electrodes:

The formula for calculating the resistance value of pipe and plate earth electrode and the different factors on which the resistance value depends are explained in the previous article.

The calculation for surface are and the earth electrode resistance values for plate and pipe earth electrodes are as follows.

Surface Area:

Let us consider plate electrodes of dimensions (1.2X1.2)m and (0.6X0.6)m for analysis.

Surface Area of both sides of Plate Electrodes = 2*l*w (in m ²)				
S.No	Length (m)	Width (m)	Area of one side (m ²)	Area of both sides (m ²)
1	0.6	0.6	0.36	0.72
2	1.2	1.2	1.44	2.88

Table 3. Surface area of plate electrode

Let us consider pipe electrodes of length 3m and diameter 50mm and 76mm.

Surface Area of Pipe Electrodes = 3.14*d*l (in m ²)			
S.No	Length, l (m)	Diameter, d (m)	Surface Area of pipes (m ²)
1	3	0.05	0.47
2	3	0.076	0.72

Table 4. Surface area of pipe electrode

From the above calculations, we can find that plate electrode of dimension 0.6m X 0.6m and pipe electrode of diameter 0.076m(76mm) and length 3m have almost same surface area.

Resistance:

Let us consider soil resistivity (ρ)of 100 Ω m for calculating the resistance value.

The resistance value of Plate electrode can be calculated as follows,

$$R = \frac{\rho}{4} \sqrt{\frac{\pi}{A}} \text{ ohms}$$

Dimension - 0.6mX0.6m; Surface Area - 0.72 m ² ; $\rho = 100 \Omega\text{m}$	Dimension - 1.2mX1.2m Surface Area - 2.88 m ² ; $\rho = 100 \Omega\text{m}$
$R = \frac{100}{4} \sqrt{\frac{3.14}{0.72}}$ $= 25 * \sqrt{4.36}$ <p>R = 52.208 Ω</p>	$R = \frac{100}{4} \sqrt{\frac{3.14}{2.88}}$ $= 25 * \sqrt{1.09}$ <p>R = 26.1 Ω</p>

Table 5. Resistance value of plate electrode

The resistance value of Pipe electrode can be calculated as follows,

$$R = \frac{100\rho}{2\pi l} \log_e \frac{2l}{d} \text{ ohms}$$

Diameter, d - 5cm; Length, l - 300cm; $\rho = 100 \Omega\text{m}$	Diameter, d - 7.6cm; Length, l - 300cm; $\rho = 100 \Omega\text{m}$
$R = \frac{100 * 100}{2 * 3.14 * 300} \log_e \frac{2 * 300}{5}$ $= 5.308 * \log_e 120$ <p>R = 25.41 Ω</p>	$R = \frac{100 * 100}{2 * 3.14 * 300} \log_e \frac{2 * 300}{7.6}$ $= 5.308 * \log_e 78.95$ <p>R = 23.19 Ω</p>

Table 6. Resistance value of pipe electrode

Note:

In the above resistance calculation for pipe earth electrode, soil resistivity will be in Ωm whereas the length and diameter will be in cm as per IS 3043.

Conclusion:

S.No	Soil Resistivity	Plate Earthing		Pipe Earthing	
		Dimension	Resistance	Dimension	Resistance
1	100 Ωm	0.6m X 0.6m Area: 0.72m ²	52.208 Ω	Dia-7.6cm Length- 300cm Area: 0.72m ²	23.19 Ω

Table 7. Comparison of plate and pipe earth electrodes

From the above calculations, we can compare the resistance values of pipe electrode and plate electrode having same surface area of 0.72m². The resistance value of plate electrode 52.2 Ω is greater than that of pipe electrode of 23.19 Ω for same surface area of 0.72m².

IS3043 states that, to obtain a low overall resistance value, the current density should be as low as possible in the medium adjacent to the electrode. This requirement is met by making the dimensions in one direction large as compared with those in the other two, thus a pipe, rod or strip has a much lower resistance than a plate of equal surface area.

1.6 Impact of Soil Resistivity on Solid Grounding

Introduction:

The electrolytic resistance of any earth electrode is made up of following factors:

- Resistance of the (metal) electrode,
- Contact resistance range between the electrode and the soil
- Resistance of the soil from the electrode surface to infinite earth.

Among these three, soil resistivity plays a vital role in performance of earthing.

Soil Resistivity:

Soil resistivity has a direct effect on the resistance of the earthing system and it is an indication of a given soil's ability to carry electric current to flow.

Earth conductivity depends on some of the contributory factors on given below

- Moisture contents of soil,
- Chemical composition,
- Concentration of soil dissolved in water,
- Grain size and distribution,
- Closeness of packaging.

Hint: Many of these factors may vary locally, occasionally and seasonally as well.

Effect of Temperature on Earth Resistivity

- Soil has negative temperature coefficient of resistivity which means that when the temperature decreases, the resistivity increases.
- If the temperature reduces below 0°C, the water in the soil starts to freeze and hence the resistance increases if the temperature drops below the freezing point of water.
- Therefore, it is recommended to increase the depth of the earth electrode well below the frost line.

Effect of moisture content on Earth Resistivity

- Moisture content is one of the controlling factors in measuring soil resistivity.
- IS 3043 specifies that if moisture content in soil decreases below 20%, the resistivity increases rapidly and the resistivity saturates for moisture content above 20%.
- The moisture content of soils in dry season will be around 10% and the same will be around 35% in wet seasons. The average moisture content will be approximately 16 to 18 percent.

- Since the moisture content will be higher during the wet season, the resistivity will be lower than the actual value and hence it is not advisable to conduct earth resistivity tests during the wet.
- However, the moisture content alone won't reduce the soil resistivity. The soil should have other minerals and also the water should not be in the purest form to obtain the best possible result as the resistivity of pure water will be higher.

The soil resistivity values for various types of soils during different climatic condition as specified by IS 3043 are as shown below.

S No	Type of soil	Probable Value Ωm	Climatic condition	
			Normal and High Rainfall (for Example, Greater than 500 mm a year)	Low Rainfall and Desert condition (For Example, less than 250 mm a year)
			Range of values encountered Ωm	Range of values encountered Ωm
1	Alluvium and lighter clays	5	*	*
2	Clays (excluding alluvium)	10	5 to 20	10 to 100
3	Porous lime stone (for example chalk)	50	30 to 100	
4	Porous sandstone	100	30 to 300	
5	Quartzites and crystalline limestone	300	100 to 1000	
6	Clay slates and slaty shales	1000	300 to 3000	1000 upwards
7	Granite	1000		
8	Fossil slates, schists gneiss igneous rocks	2000	1000 upwards	

* Water level of locality

Table 8. Soil resistivity of different soils at different climatic conditions

Effect of salt content on Earth Resistivity

- Pure water is bad conductor of electricity. Resistivity of soil depends on the resistivity of water which in fact depends on the amount and nature of salts dissolved in it.
- We can't keep on reducing the soil resistivity value by increasing the salt content. There will be greater reduction in the soil resistivity if the salt content in moisture is lesser than 5%. But there won't be any considerable reduction in the resistivity value once the salt content in the moisture exceeds 5%.
- Increasing the salt content will result in reduction of soil resistivity at the same time the corrosion rate will increase as the salt content increases.

1.7 Parallel Connection of Earth Electrode

Introduction:

Earthing is the process of connecting the current carrying and non-current carrying metal parts of an electrical system to dissipate the currents to the ground. The earth electrode resistance value mainly depends on the resistivity of the soil. If the desired earth resistance value cannot be achieved with single earth electrode on the specific soil condition, then the earth resistance value can be reduced either by connecting multiple electrodes in parallel or by using artificial treatment of soil.

Parallel Connection of Earth Electrodes:

The effective combined resistance value of multiple electrodes in parallel connection is inversely proportional to the number of earth electrodes i.e higher the number of electrodes in parallel connection lower will be the effective resistance value. The spacing between the earth electrodes plays a major role in calculating the effective resistance and sufficient spacing should be provided between the two adjacent earth electrodes.

If two resistors (electronic component) of same resistance values are connected in parallel, then the effective resistance will be 50% of the resistance value of single resistor. If 'n' resistors of same resistance value are connected in parallel, then the effective value will be 1/n times the resistance value of individual resistor.

But this calculation is not applicable for calculating the combined resistance values of two or more earth electrodes connected in parallel. The spacing between the two electrodes has a very huge impact on the combined resistance value. In the extreme case, if two earth electrodes are installed very close to each other, the combined resistance of two electrodes will be similar to that of one electrode.

BS7430 explains that the effect of increasing the spacing beyond two times the length of electrode is very negligible.

BS7430 explains about two configurations for parallel connection of earth electrodes.

- Electrodes in straight line.
- Electrodes in the form of Hollow Square.

The combined resistance of rod electrodes in parallel R_n , can be calculated from the following equation,

$$R_n = R \left(\frac{1 + \lambda a}{n} \right) \text{ ohms}$$

$$a = \frac{\rho}{2\pi R s}$$

Where,

R - resistance of one rod in isolation, (in Ω)

s - distance between adjacent rods, (in m);

ρ - resistivity of the soil, (in $\Omega \cdot m$);

λ – factor which varies for configuration and number of electrodes; n – is the number of electrodes

In the above formula, the factor (λ) value changes for configuration and the number of electrodes connected in parallel.

From the above formula we can observe that the spacing between the earth electrodes also plays a major role in determining the combined resistance value of multiple earth electrodes in parallel connection.

Parallel Electrodes in Straight line:

If the rods are equally spaced in a straight line an appropriate value of λ may be taken from the below Table. The spacing between the rods should not be lesser than the length of an electrode.

Number of electrodes(n)	Factor (λ)
2	1
3	1.66
4	2.15
5	2.54
6	2.87
7	3.15
8	3.39
9	3.61
10	3.81

Table 9. Parallel electrodes in straight line configuration

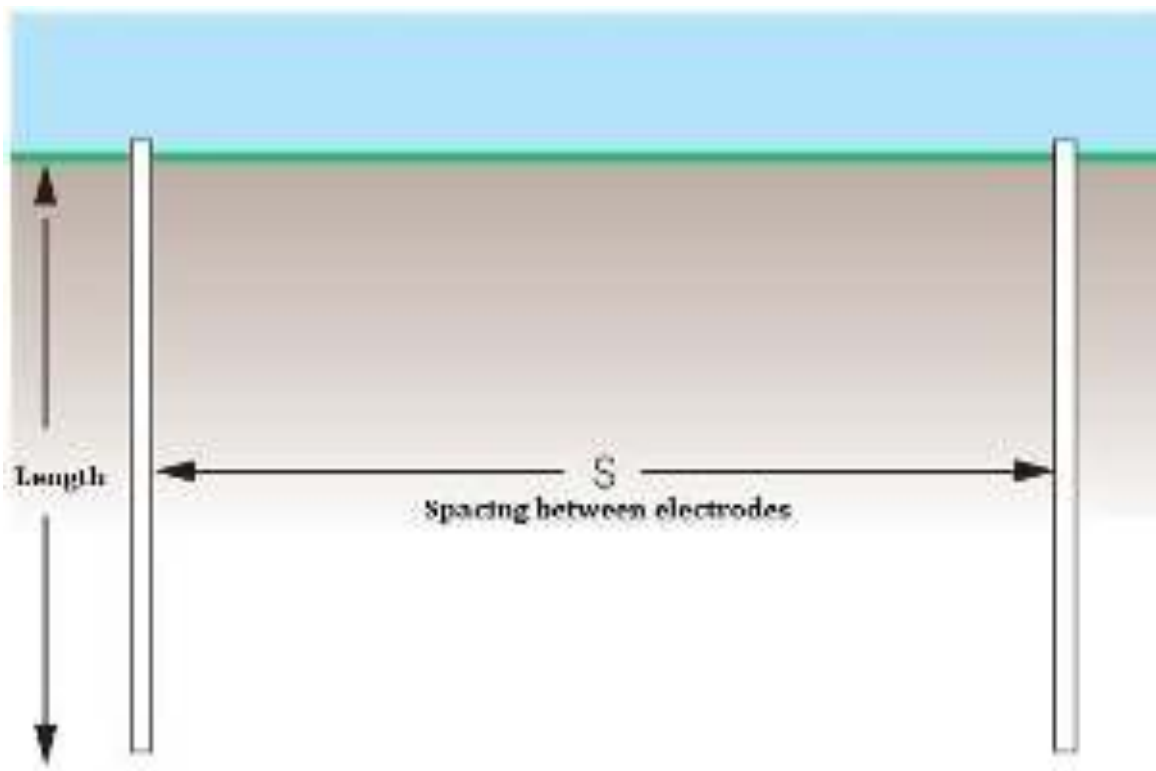

Figure 7. Parallel electrodes in straight line configuration

Parallel Electrodes in Hollow Square configuration:

If the earth electrodes are placed along the perimeter of a hollow sphere at regular intervals similar to the electrodes installed around the perimeter of a square building, the value of λ taken from Table below.

If three rods are placed in the shape of equilateral triangle, or in an L formation, a value of $\lambda = 1.66$ corresponding to 3 electrodes from the below table may be assumed.

Number of electrodes (n) along each side of the square	Factor (λ)
2	2.71
3	4.51
4	5.48
5	6.14
6	6.63
7	7.03
8	7.36
9	7.65
10	7.9
12	8.32
14	8.67
16	8.96
18	9.22
20	9.4

Table 10. Parallel electrodes in hollow square configuration

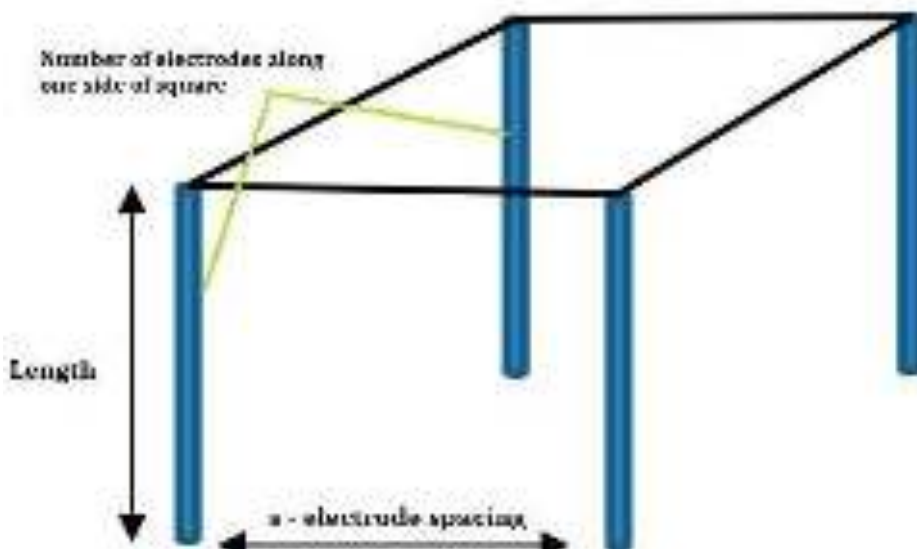

Figure 8. Parallel electrodes in hollow square configuration

Multiple Earth Electrodes:

If the required earth resistance value could not be achieved with the help of single earth electrode, multiple electrodes shall be installed and connected together in parallel for achieving the desired value.

However, the spacing between the ground rods will have some impact on the combined resistance. In the extreme case if two electrodes are installed very adjacent to each other then the resistance of two electrodes will be similar to that of one electrode. In practice, the separation between the two electrodes should be at least equal to the driven depth of electrodes. Hence for an electrode of 3m length, the separation distance between adjacent electrodes shall not be less than 3m. There will be considerable effect on the earth resistance even at separation of 2m distance.

Electrodes with Improper spacing:

If the earth electrodes are closer to each other then the dissipation of one electrode overlaps with the other electrode. This overlap reduces the performance of an earth electrode.

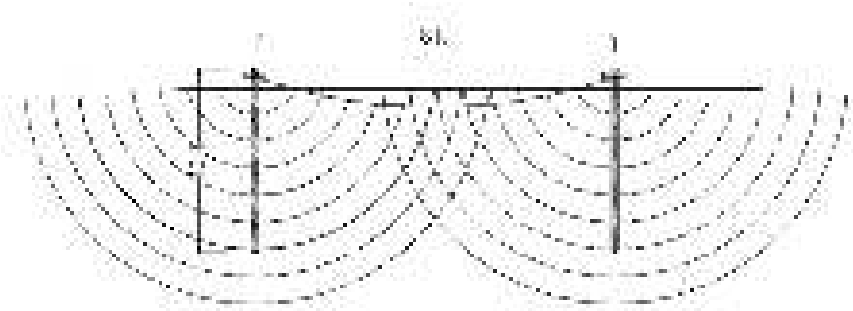

Figure 9. Improper spacing between the earth electrodes

Electrodes with proper spacing:

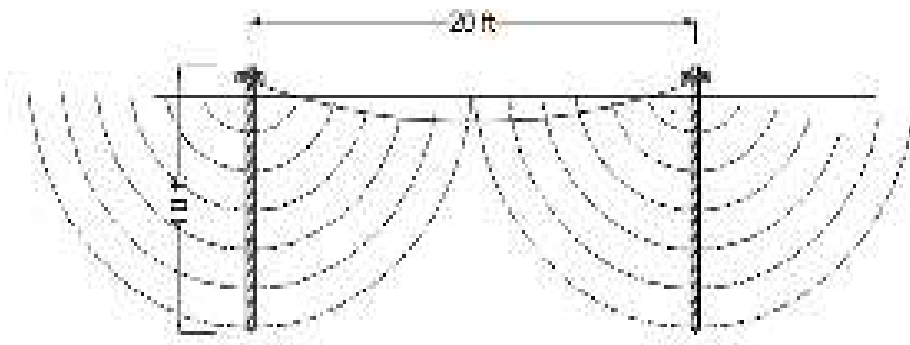

Figure 10. Proper spacing between earth electrodes

1.8 Selection of Metal for Earth Electrode

The earth resistance of an earth electrode does not depend on the material used, but the materials should be selected by considering the corrosion resistance property of those materials. Even though aluminum or copper-clad aluminum conductors have very good conductivity they should not be used as earthing conductor and should not be used to make the final connection to an earth electrode.

Apart from the corrosion due to the direct exposure of the metal to soil and water, there occurs one more corrosion when two different materials are connected to each other. This type of corrosion is termed as galvanic corrosion.

Galvanic Corrosion:

When two dissimilar metals are connected together, one metal becomes more electronegative resulting in corrosion. Hence critical care and attention is to be taken while connecting dissimilar metals in order to avoid galvanic corrosion. Galvanic corrosion is also termed as dissimilar metal corrosion or bimetallic corrosion.

The potential difference between the galvanic couple plays a major factor in corrosion. Hence while connecting two dissimilar metals, the materials selected should have a low potential difference between them from galvanic series.

A galvanic series is a list of metals and alloys arranged according to their corrosion potentials or galvanic potentials as measured in a given environment. Zinc can act as a perfect 'sacrificial Anode' to protect metals like Steel from corrosion.

Measures to Reduce Galvanic Corrosion

- The potential difference between the two different metals in the galvanic series should be as low as possible.
- The ratio of the cathode to anode area is proportional to the galvanic corrosion. A smaller anode and a larger cathode will increase the current density at the Anode resulting in large galvanic corrosion.
- The dissimilar metals should be insulated wherever possible.

Selection of Materials for Earth Electrodes:

Some of the commonly used materials and the requirements specified by the standards are as follows.

Copper Electrodes:

Copper electrodes have good corrosion resistance in addition to their high conductive property in many environments. Hence except for acid, oxygenated ammoniac or sulphurous conditions, copper are suitable for use in the most earth electrode applications.

Hot Dip Galvanized Steel Electrodes:

A galvanized mild steel earth electrode experiences considerable and apparently permanent protection to corrosion but the effect is intensified in environments with high chloride contents.

It should be noted that galvanized steel should be used for earth electrodes in soil only when steel parts in the concrete are not directly connected to the earth electrode in soil.

Stainless Steel Electrodes:

Stainless steel electrodes have good corrosion resistance in many environments. However, in clay soils, they corrode quickly as mild steel. The stainless-steel earthing systems can even be connected directly to the steel reinforcement in concrete.

IEC 62561 part 2 provides details about the specification of materials for earth electrodes. Some of the details provided in the standard are listed below and for complete details Table 5 of IEC62561 part 2 shall be referred.

Material	Configuration	Dimensions		
		Earth rod diameter mm	Earth conductor mm ²	Earth plate mm
Copper Tin plated copper	Stranded		50	
	Solid round	15	50	
	Solid tape		50	
	Pipe	20		
	Solid plate			500 x 500
Hot dipped galvanized steel	Solid round	14	78	
	Pipe	25		
	Solid tape		90	
	Solid plate			500 x 500
Copper coated steel	Solid round	14	50	
	Solid tape		90	
Stainless steel	Solid round	15	78	
	Solid tape		100	

Table 11. Requirements for earth electrodes

1.9 Why Copper is more preferable for Earthing?

Introduction:

Reddish metal (Copper) is a noble metal that occurs naturally in its elemental form. And also, copper is a versatile metal not only its unique properties of high electrical conductivity and high thermal conductivity but combination of these and other properties of copper.



Figure 11. Copper pipes

Electrical Conductivity:

It is the property of every metal to resist the flow of electrical current and each material has its own resistivity. Lower the resistivity, higher will be the electrical conductivity. Copper has low resistivity, so it is considered as an excellent electrical conductivity.

Corrosion Resistance:

Copper is suitable for using in most of the earth electrode applications not only for high conductivity, but also for superior corrosion resistance property.

As per IS 3043, the specimen of (150x25x3)mm of different material (copper, galvanized steel and mild steel without coating) has been buried in variety of soil for 12 years for analysing the corrosion resistance properties. Copper whether it is tinned or not, the average loss of specimen did not exceed 0.2 percent per year.

Similarly, Copper earthing conductors, in general, need not be protected against corrosion when they are buried in the ground if their cross-sectional area is equal to or greater than 25 mm².

Ease of Joining

Copper can be readily joining by the following methods,

- Brazing using zinc-free brazing material with a melting point of at least 600°C;
- Bolting;
- Riveting and sweating; and
- Explosive welding.

Mechanical Strength:

Copper is both malleable and ductile metal, which means that it could be stretched to a good length without breaking or weakening it. They can be bended to fit around corners. The reddish metal stands well on this parameter.

Copper can be easily shaped into pipes, plates, flats, wires and rods. The copper pipes are light weighted because they have thin walls.

Temperature Tolerance:

During the fault conditions, the magnitude of current flowing through the conductor will be much higher and hence the heat generated also will be higher. As per UL 467, the melting point of copper conductor is 1083°, so it can be used for high temperature application. So, therefore copper has high temperature tolerance than other material using in earthing.

Copper can be easily combined with other metals to make alloy and it is non-magnetic and non-sparking material.

Conclusion:

Copper is not only having lower resistance but also combination of other unique properties along with the superior corrosion resistance property makes it more suitable for earthing applications.

1.10 Sizing of Earth Conductor

Introduction:

An earth electrode should be capable of dissipating the fault current into the earth without any physical damages and without much increase in temperature. It should be sufficiently robust to withstand mechanical damage and corrosion.

Hence the cross-sectional area of the conductor should be selected based on the expected maximum fault current and the duration of the fault current. IS 3043 explains about the calculation for minimum cross-sectional area of earthing conductor based on the fault current level.

Minimum Cross-Sectional Area:

Improper material sizing may lead to melting of earthing conductor due to overheating and selecting conductors of higher cross-sectional area will increase the overall cost of installation. Hence proper conductor size should be selected based on the fault level of the respective sites.

The minimum cross-sectional area for the earthing conductor as specified by IS3043 is as follows.

Minimum Cross-Sectional Area of Earthing conductors		
	Mechanically Protected	Mechanically Unprotected
Protected against corrosion	16 mm ² (Cu) 16mm ² (Fe)	16 mm ² (Cu) 16mm ² (Fe)
Not protected against corrosion	25 mm ² (Cu) 50 mm ² (Fe)	

Table 12. Minimum cross sectional area of earthing conductors

Calculation for Cross section area:

The cross-sectional area for specific fault current value shall be calculated by using the following formula provided by IS3043, (applicable only for disconnection times not exceeding 5s)

$$S = \frac{I\sqrt{t}}{k}$$

Where,

S - Cross-sectional area, in mm²;

I - value (ac, rms) of fault current, in amperes;

t - Operating time of the disconnecting device, in seconds; and

k = factor dependent on the material of the protective conductor, the insulation and other parts, and the initial and final temperatures.

If application of the formula produces nonstandard sizes, conductors of the nearest higher standard cross-sectional area shall be used.

The commonly used earthing materials are,

- Copper
- Aluminum
- Steel

The earthing conductor shall be in different configurations and the value of 'k' varies for different configuration of material. IS 3043 specifies the 'k' value for the following configurations of earthing conductors.

- Bare Conductor with No Risk of Fire.
- Insulated Protective Conductors not incorporated in Cables or Bare Conductors Touching Other Insulated Cables.
- Protective Conductor as a Core in Multicore Cables.
- Protective Bare Conductors in Hazardous Areas

The value of 'k' for all the above-mentioned configurations are specified in IS3043 and few of them are as follows.

	1 s current rating in A/mm ² (k ₁)			3 s current rating in A/mm ² (k ₃)		
	PVC	Butyl Rubber	XLPE/EPR	PVC	Butyl Rubber	XLPE/EPR
Bare conductor with no risk of fire	205			118		
Protective bare conductors in hazardous area where there is risk of fire	131/153			76/88		
Insulated protected conductors not incorporated in cables or bare conductors touching other insulated cables	136	160	170	79	92	98
Protective conductor as a core in multicore cables	115	134	143	66	77	83

Table 13. k factor values

The cross-sectional area of earthing conductor shall be selected based on the size of the phase conductors used on the site. The cross-sectional area of the conductors in such cases shall not be less than the values specified below.

S. No	cross-sectional area of phase conductors of the installation S (mm ²)	Minimum cross-sectional area of the corresponding protective conductor S _p (mm ²)
1	S < 16	S
2	16 < S < 35	16
3	S > 35	S/2

Table 14. Cross sectional area of protective conductor

The values in the above table are valid only if the protective conductor is made of the same metal as the phase conductors.

1.11 Current Carrying Capacity of Different Materials

The Earth electrodes should be designed to withstand the fault current. The fault current carrying capacity of a material mainly depends on cross sectional area. In this article we have explained current carrying capacity of different dimensions of different materials of pipes and strips at different time of operation.

In general, the amount of electric current flowing per unit cross sectional area of a material is called current density of a material.

The current density of the earth electrode can also be calculated by the formula,

$$\frac{I}{S} = k * \frac{1}{\sqrt{t}} \text{ A/m}^2$$

The k factor can be derived by the following formula provided by IS3043,

$$k = \sqrt{\left(\frac{Q_c(B + 20)}{\delta_{20}} \ln\left(1 + \frac{\theta_t - \theta_1}{B + \theta_1}\right)\right)}$$

Where,

Q_c = volumetric heat capacity of conductor material (J/°C mm³),

B = reciprocal of temperature coefficient of resistivity at 0°C for the conductor (°C),

δ_{20} = electrical resistivity of conductor material at 20°C Ω .mm),

θ_1 = initial temperature of conductor (°C),

θ_t = final temperature of conductor (°C).

IS 3043:2018 has given the values of these constants Q_c , B, δ_{20} for copper, steel and aluminium. The initial temperature as 40°C and the final temperature varies with respect to safe and hazardous area. We shall calculate considering temperature in both safe as well as hazardous area.

Fault current carrying capacity of strip:

25mm X 3mm Copper strip at t = 1s.	25mm X 3mm Copper strip at t = 3s:
k = 205A/mm ²	k = 118A/mm ²
t = 1 s	t = 3 s
S = 75mm ²	S = 75mm ²
I = (205 x 75)/√1	I = (118 x 75)/√3
I = 15375 A ≈ 15.4 kA	I = 9526 A ≈ 9.5 kA

Table 15. Current carrying capacity of copper strip

The value of k is provided in the previous article under Table 13.

Current carrying capacity of Class A, B and C Steel pipe for t = 1s:

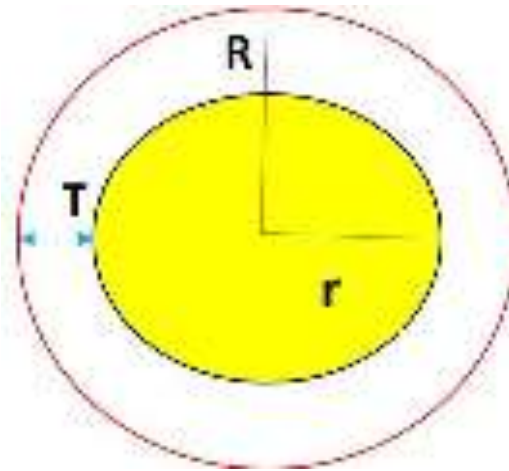

Figure 12. Cross section of pipe

The terminologies which we used for the calculation are as follows.

R - Outer diameter of the pipe

r - Inner diameter of the pipe

T - Thickness of the pipe

Safe Area:

Initial temperature: 40 °C, Final temperature: 500 °C

R.M.S current density k for steel at given temperature= 80A/mm²

Class A	Class B	Class C
Diameter: 48mm	Diameter: 48mm	Diameter: 48mm
Thickness: 2.9mm	Thickness: 3.2mm	Thickness: 4mm
$S = \pi * (R^2 - r^2)$	$S = \pi * (R^2 - r^2)$	$S = \pi * (R^2 - r^2)$
R = 48/2	R = 48/2	R = 48/2
R = 24mm	R = 24mm	R = 24mm
$r = (48 - 2*2.9)/2$	$r = (48 - 2*3.2)/2$	$r = (48 - 2*4)/2$
= 21.1mm	= 20.8mm	= 20mm
S = 410.68mm ²	S = 450.15mm ²	S = 552.64mm ²
$I = S * k * \frac{1}{\sqrt{t}} \text{ A/m}^2$	$I = S * k * \frac{1}{\sqrt{t}} \text{ A/m}^2$	$I = S * k * \frac{1}{\sqrt{t}} \text{ A/m}^2$
$I = (410.68 * 80) / \sqrt{1}$	$I = (450.15 * 80) / \sqrt{1}$	$I = (552.64 * 80) / \sqrt{1}$
I = 32,854A ≈ 32.85kA	I = 36012A ≈ 36.01kA	I = 44211A ≈ 44.21kA

Table 16. Current carrying capacity of pipes on safe area

Hazardous Area:

Initial temperature: 40 °C, Final temperature: 200 °C

R.M.S current density k for steel at given temperature= 56 A/ mm²

Class A	Class B	Class C
Diameter: 48mm Thickness: 2.9mm $S = \pi * (R^2 - r^2)$ $R = 48/2$ $R = 24\text{mm}$ $r = (48 - 2*2.9)/2$ $= 21.1\text{mm}$ $S = 410.68\text{mm}^2$ $I = S * k * \frac{1}{\sqrt{t}} \text{ A/m}^2$ $I = (410.68 * 56)/\sqrt{1}$ $I = 22,998\text{A} \approx 22.99\text{kA}$	Diameter: 48mm Thickness: 3.2mm $S = \pi * (R^2 - r^2)$ $R = 48/2$ $R = 24\text{mm}$ $r = (48 - 2*3.2)/2$ $= 20.8\text{mm}$ $S = 450.15\text{mm}^2$ $I = S * k * \frac{1}{\sqrt{t}} \text{ A/m}^2$ $I = (450.15 * 56)/\sqrt{1}$ $I = 25208\text{A} \approx 25.2\text{kA}$	Diameter: 48mm Thickness: 4mm $S = \pi * (R^2 - r^2)$ $R = 48/2$ $R = 24\text{mm}$ $r = (48 - 2*4)/2$ $= 20\text{mm}$ $S = 552.64\text{mm}^2$ $I = S * k * \frac{1}{\sqrt{t}} \text{ A/m}^2$ $I = (552.64 * 56)/\sqrt{1}$ $I = 30947\text{A} \approx 30.95\text{kA}$

Table 17. Current carrying capacity of pipes on hazardous area

The summary of the current carrying capacity of pipes for safe and hazardous conditions is as follows.

S.No	Materials of Electrode	Dimensions	Current carrying capacity at safe area with no risk of fire	Current carrying capacity at hazardous area
1	Class A Steel Pipe	Diameter: 48mm Thickness: 2.9mm	32.85kA	22.99kA
2	Class B Steel Pipe	Diameter: 48mm Thickness: 3.2mm	36.01kA	25.20kA
3	Class C Steel Pipe	Diameter: 48mm Thickness: 4mm	44.21kA	30.95kA

Table 18. Comparison of current carrying capacity on safe and hazardous area

From the above calculations, we can find that

- Current carrying capacity of 48mm dia. pipe is not same for all the classes and it depends on the thickness of the pipe.
- Current carrying capacity of the material won't be the same for safe and hazardous operating temperature.
- Current carrying capacity of strips of different materials (Copper and Steel) having same cross sectional area won't be same as the k factor value is different for copper and steel.

Conclusion:

From the above calculations based on IS3043:2018, we can conclude that the fault current carrying capacity depends on the cross-sectional area and k factor of the material. The k factor depends on the temperature of different area and the material of the electrode at given operating time.

1.12 UL 467 - Grounding and Bonding Equipment

Introduction:

UL stands for Underwriters Laboratories, a non-profit safety organization established over 100 years ago. UL is one of the world's oldest safety certification companies. Through comprehensive procedures and guidelines UL requires their standards are met before certification is granted. Another part of the agreement is traceable labels. Each product listed must have a label affixed to the product traceable to the manufacturer through Underwriters Laboratories.

UL467:

UL 467 - Standard for safety for grounding and bonding equipment, explains about the requirements for connecting clamps, bonding equipment, wire mesh and earth electrodes. It explains about the specifications, test requirements and testing procedure of earth electrodes.

Earth Electrodes:

Rod Electrode:

- The rod electrode shall not be less than 3m of length. If the rod has to be used in US, the length of rod electrode shall not be less than 2.44m.
- An uncoated solid rod electrode of SS, copper or suitable non-ferrous metal shall have a diameter not less than 12.7mm. For Mexico, the diameter should be not less than 14.8mm
- A coated solid rod electrode shall have a diameter not less than 12.7mm.
 - The stainless-steel coating shall not be less than 0.38mm thick at any point.
 - The copper coating shall not be less than 0.25mm thick at any point.
 - The zinc coating shall not be less than 0.099mm thick at any point.
- The stainless-steel coating or a stainless-steel rod should contain 18% chromium and 8% nickel type.

Chemically Charged Rod Electrode:

Chemically charged rod electrodes are made of a hollow tube made of copper or equivalent material filled with corrosion resistant chemical substances.

- The hollow tube is made of copper or equivalent material resistant to corrosion having an internal diameter not less than 49.3mm and wall thickness not less than 1.93mm.
- The chemical charge within the rod electrode shall be a substance that does not cause the electrode to corrode at a faster rate.

Test Methods:

Short time current test:

Once the test set up is made, the test current shown in below table shall be passed through the sample. The current values are provided by UL 467 in Table 5. After supplying the current for specified duration, continuity of the materials should be checked. A grounding or bonding device should not crack, break, or melt when subjected to the current and time specified by the standard.

The current values of electrode materials other than the copper, aluminium and steel rebars ones listed in Table 5 can be derived as per Annex C of IEEE std 837-2002.

The formula provided by IEEE for calculating the short time current is as follows.

$$I = A \sqrt{\frac{\ln \frac{k_p + T_m}{K_p + T_a}}{\beta * t}}$$

Where,

T_m = 1083°C for melting point for copper and 657°C for melting point for aluminum and 1510°C for melting point for steel

T_a = 40°C = ambient temperature

I = short time current(ampere)in kA

A = conductor cross section in mm²

T = time(s)

K_o = reciprocal of thermal coefficient of resistivity at 0°C =234 for copper and 228 for aluminum and 605 for steel

β =material constant = 19.8 for copper and 45.1 for aluminum and 77.5 for steel

Thickness of protective coating:

The thickness of a protective coating shall be determined by a reliable electronic or magnetic or by an electrochemical method. The measured thickness of any protective coating shall comply with the values specified by the standard.

Adherence of coating test:

A rod of length 457 mm (18 in) with one end cut to a 45° point and it will be driven between two steel clamping plates or the jaws of a vise set 1.02 mm lesser than the diameter of the rod to shear off sufficient metal for exposing the bond between the coating and rod. The coating should not be separated from the steel core when subjected to adherence of coating test.

Bending Test:

A length of the rod shall be rigidly held in a clamp or vise. A force shall be applied normal to the free end of the rod such that the rod is permanently bent through a 30° angle. There should not be any cracks on the coating of electrode after bend test. The testing arrangement is shown below.

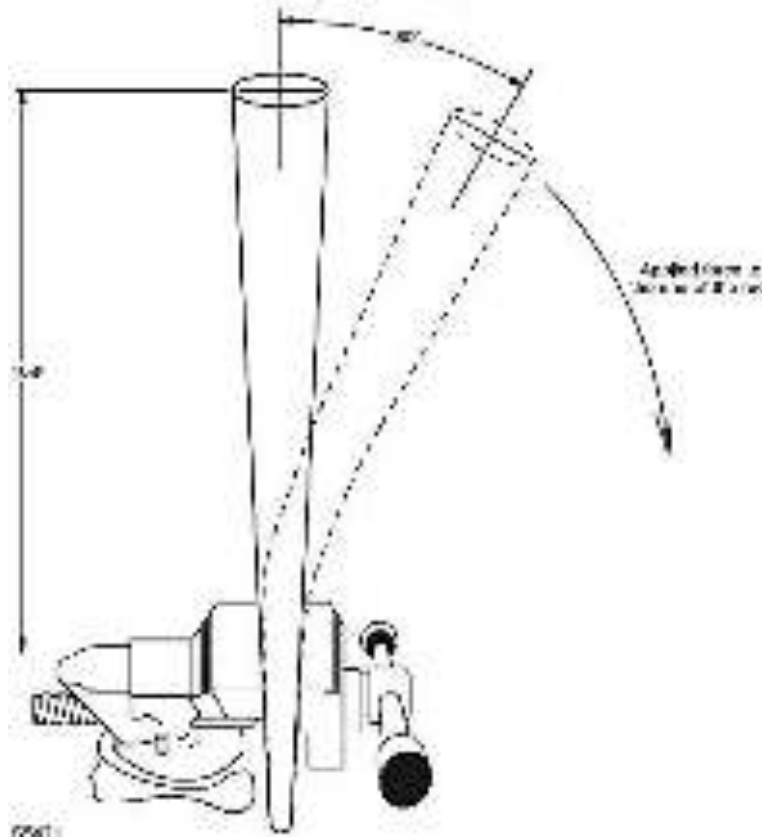

Figure 13. Bend test arrangement

Marking on Earth electrodes:

The marking of a ground rod should be done within 305 mm from the top of the rod and shall include the following details.

- the manufacturer's name, trade name, or both, or any other distinctive marking
- a distinctive catalog number or an equivalent identification; and
- The length of the rod.

We can verify the certification of the product using the Online Certifications Directory. The Online Certifications Directory includes the names of companies authorized to use the UL Mark on or in connection with products in compliance with UL's requirements.

Conclusion:

Having UL Listing guarantees that the product fully complies with each and every one of UL's requirements in the applicable standard. Since UL467 explains about all the requirements of earth electrodes (dimensions, coating thickness, adherence of coating, bending and current carrying capacity), the products tested and certified as per UL 467 will be of very good quality. Because of very stringent testing procedures, UL certification makes the earth electrodes more reliable and provides unbiased accuracy of safety.

1.13 Requirements and Testing of Earthing Components

Introduction:

IEC 62561:2018 Part 2 explains about the “Requirements for conductors and earth electrodes” which is a part of the lightning protection system. IEC 62561-2 specifies the requirements and tests for:

- Metallic conductors other than natural conductors that form part of the Lightning Protection System;
- Metallic earth electrodes

Earth Electrode

Earth rods shall be mechanically robust and should have good corrosion resistance property. It should be ensured that,

- No cracking of the rod takes place during installation.
- The threads on the rods should be smooth and the threads also should be properly coated.
- For copper coated rods, the copper coating should not be removed from the steel.

The cross sectional area requirements specified in IEC62561 for the earth electrodes are as follows.

Material	Configuration	Cross-section area of Earth rod mm ²	Recommended dimensions
Copper, Tin plated copper	Solid round	≥ 175	15 mm diameter
	Pipe	≥ 110	20 mm diameter with 2 mm wall thickness
Hot dipped galvanized steel	Solid round	≥ 150	14 mm diameter
	Pipe	≥ 140	25 mm diameter with 2 mm wall thickness
Copper coated steel	Solid round	≥ 150	14 mm diameter if 250 um minimum radial copper coating with 99.9 % copper content
Stainless Steel	Solid round	≥ 176	15 mm diameter

Table 19. Requirements for earth electrodes

Testing:

Earth conductors shall be subjected to the following tests to confirm their suitability for the intended application.

- Test for thickness of coating on earth rods
- Adhesion test
- Bend test
- Environment test
- Electrical Resistivity Test
- Tensile Test
- Test for yield/tensile ratio

1.14 Earth Enhancing Compound

Introduction:

Earthing is the process of connecting the current carrying and non-current carrying metal parts of an electrical system to dissipate the currents to the ground. The major components of earthing are

1. Earth Electrode
2. Earth enhancing compound or Back fill compound
3. Terminal connector

Earth Enhancing Compounds:

Earth enhancing compounds (EEC) are highly conductive compounds which are filled around the earth electrode by replacing the existing high resistance soil to provide low earth resistance value and improve the performance of earthing system.

Why do we need EEC/BFC?

In areas with soils of high resistivity, multiple earth rods in parallel may sometime fail to produce the desired low resistance to earth. The alternative is to reduce the resistivity of the soil immediately surrounding the earth electrode.

The greater part of the fall in potential occurs in the soil within a few feet of the electrode surface, since it is here that the current density is highest. To obtain a low overall resistance the current density should be as low as possible in the medium adjacent to the electrode, which should be so designed as to cause the current density to decrease rapidly with distance from the electrode.

Hence, using highly conductive earth enhancing compounds around the earth electrode is an effective way of achieving low earth resistance value.

Characteristics of EEC/BFC:

Since the materials are used directly on soil, the impact of these materials on environment is very high and it may pollute the land and ground water. Hence, special care should be taken on selecting the materials for BFC. The materials should have the following characteristics.

- It should be chemically inert to subsoil
- It should not pollute the environment.
- It should provide a stable environment in terms of physical and chemical properties and exhibit low resistivity.
- It should not be corrosive to the earth electrodes being used.
- It should be hygroscopic in nature
- It should be able to maintain moisture to enhance conductivity
- It should not leach into normal soil

The artificial treatment may be effective over a period of many years but earth resistance value should be made measurement either annual or biannual to find out if additional treatment is needed.

IS 3043 specifies that the following substances shall be used for artificial treatment of soil.

- Common Salt, NaCl - Sodium chloride,
- CaCl_2 - Calcium chloride,
- Na_2CO_3 - Sodium carbonate,
- CuSO_4 - Copper Sulphate,
- Salt and soft coke, salt and charcoal in suitable proportions.

In artificial treatment of earth electrodes, the corrosion effect of salts on the electrodes should be considered. The earth enhancing compounds shall be used either in dry form or in slurry form.

Calculation for Earth Resistance Value:

BS7430 explains the procedure for calculating the earth resistance value in the presence of Earth Enhancing Compound.

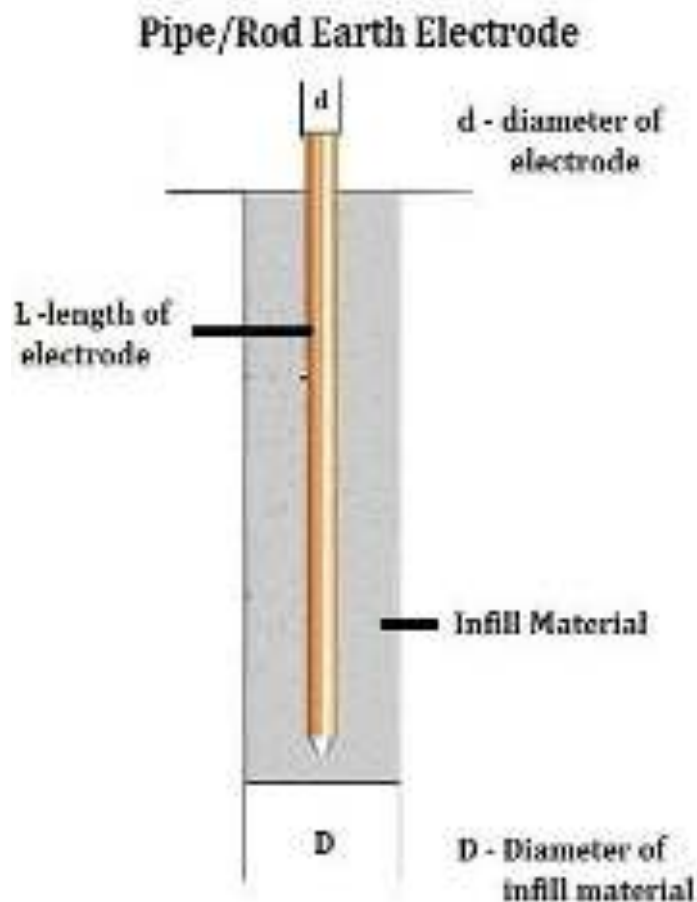

Figure 14. Earthing arrangement with earth enhancing compound

The formula for finding the earth resistance (R) is,

$$R = \frac{1}{2\pi L} \left[(\rho - \rho_c) \left(\log_e \left[\frac{8L}{D} \right] - 1 \right) + (\rho_c) \left(\log_e \left[\frac{8L}{d} \right] - 1 \right) \right] \text{ ohms}$$

Where,

ρ – resistivity of the soil in $\Omega.m$

ρ_c – resistivity of the earth enhancing compound or infill used in $\Omega. m$

d – diameter of the electrode in m

D – diameter of the compound filled in m

L – Length of the earth electrode in m

From the above calculation, we can find that, the earth resistance value can be reduced by using earth enhancing compounds which have very low resistivity value and diameter of the material used.

1.15 Requirement and Testing of Earth Enhancing Compound

IEC 62561:2018 deals with lightning protection components (LPSC) and Part 7 explains about the “Requirement of earthing enhancing compound” which is a part of the lightning protection system. It can be implemented and installed in accordance with IEC 62305 series of Protection against lightning.

Testing methods

Considering the importance of earth enhancing compounds in providing low earth resistance and the impact that the materials can create on environment, IEC 62561-7 specifies the requirements and tests for earthing enhancing compounds producing low resistance of an earth termination system.

The tests described in this standard are type tests and hence they need not be repeated unless changes are made to the materials, design or manufacturing process. The tests are as follows,

- Leaching test
- Sulphur determination test
- Determination of resistivity test and
- Corrosion test

The testing method and Acceptance criteria of listed tests are explained below.

Leaching Test:

The leaching test shall be performed as per EN 12457-2 in order to determine the content of

- Fe (Iron);
- Cu (Copper);
- Zn (Zinc);
- Ni (Nickel);
- Cd (Cadmium);
- Co (Cobalt);
- Pb (Lead).

The concentrations of the above leachable ions shall be determined as per EN 16192.

Sulphur determination Test:

The sulphur determination test shall be performed as per ISO 4689-3 or ISO 14869-1 and the adapted analyses instrumentation (ICP-OES, ICP- AES or other ICP methods).

Passing criteria

The material is deemed to have passed the test if all measured values are less than 2 %.

Determination of Resistivity test:

The four-electrode method is used to measure the resistivity of earthing enhancing compounds as described in ASTM G57-06. Three samples of the earthing enhancement material shall be tested in a four- electrode soil box apparatus.

With the four-electrode method, current is injected on the outer electrodes and the resulting voltage drop between the inner electrodes is measured using a voltmeter and the resulting resistance is calculated.

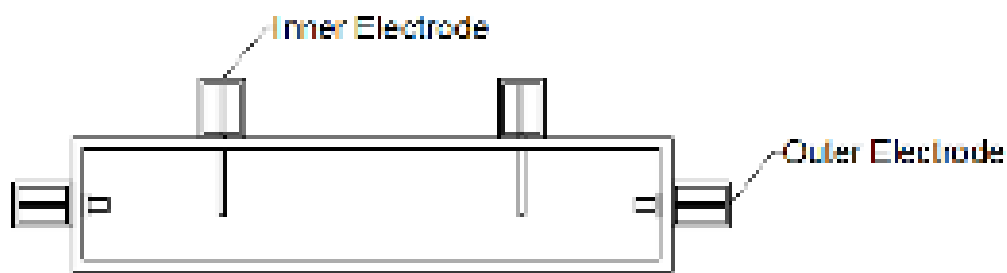

Figure 15. Four electrode soil box

The resistance of each earthing enhancing compound sample shall be converted to the resistivity value using the following formula.

$$\rho = \frac{R * A}{a}$$

Where,

ρ – sample resistivity (in $\Omega.m$)

R – resistance (in Ω)

A – cross sectional area of the container perpendicular to current flow (in m^2)

a – inner electrode spacing, measured from inner edges of electrodes (in m)

Testing Apparatus:

- Any earth resistance meter having two current and two voltage outputs shall be used.
- Four-electrode soil box made of an inert non-conductive material
- Connecting cables.

Using Earth resistance meter:

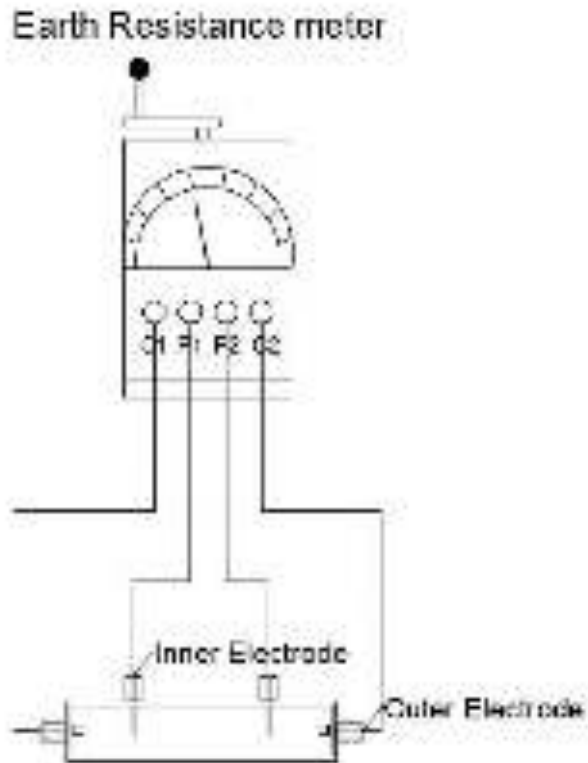

Figure 16. Measurement using four probe earth resistance meter

Using Ammeter and Voltmeter:

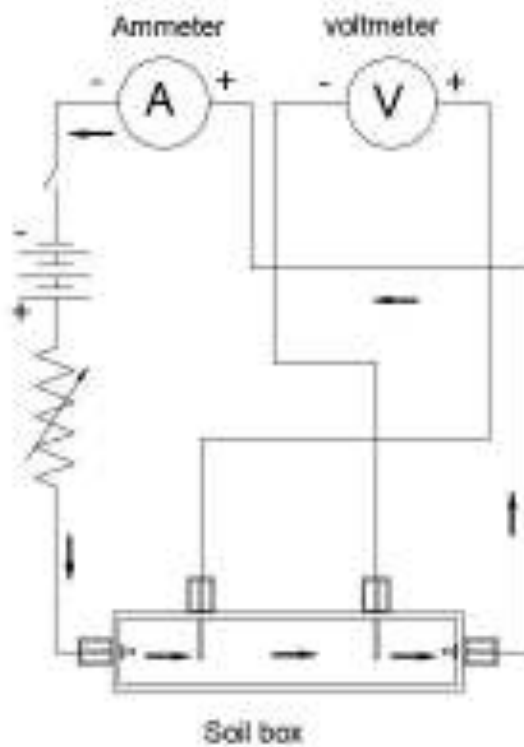

Figure 17. Measurement using ammeter and voltmeter

Test Procedure:

- The earthing enhancing compound shall be prepared according to the manufacturer's Instructions. If no preparation required, then the compound shall be tested as received.
- The resistivity measurements shall be made after curing time of the compound.
- The sample of earthing enhancing compounds shall be placed in the soil box and good electrical contact between the earth enhancing compound and the electrodes should be ensured.
- The resistance R of the samples shall be measured using the earth resistance meter or shall be calculated from the current and voltage measurements. The resistivity of each sample shall be calculated using the resistivity formula.

The test results depend on both the pressure and the moisture level of the sample under test.

Passing Criteria:

The obtained resistivity value from the three samples should be less than or equal to the resistivity value claimed.

Corrosion Test:

The earth enhancing compound should not corrode the earth electrode while reducing the resistivity of the soil immediately surrounding the electrodes. Hence we need to determine the corrosiveness of materials used as earth enhancement compounds. The corrosion rate is determined by using potentiodynamic polarization resistance methods as outlined in ASTM G59-97 and ASTM G102-89. IEC62561 explains about the testing methods and the details are as follows.

The earth enhancement materials should be physically and chemically inert with the earth electrodes to avoid the damage due to corrosion on the earthing electrode.

Test Apparatus:

A three-terminal potentiostat that can be used to impose the positive and negative potential variations and to record the currents needed to obtain potentials:

- Distilled water;
- Glassware;
- Mixer;
- Balance with an accuracy of $\pm 0,001$ g.

Test Preparation:

Prepare a mix of the earth enhancement material following the instructions.

- Place the working electrodes, reference electrodes and active electrodes into the material according to the polarization resistance method.
- Connect to the potentiostat.
- The active electrode shall be a graphite electrode.

- The reference electrode is typically Cu/CuSO₄.
- Enhancement material shall be tested after the relevant curing period.
- Enhancement material designed to be used within a dry form shall be tested with a minimum 40 % water content.

Test procedure

- Obtain the open circuit potential of the working electrode immersed in the material.
- Obtain the Tafel curve for the material.
- Determine the Tafel constants and the polarization resistance (R_p) values.

Passing criteria

For copper-plated earth electrodes, the polarization resistance shall be

- >4 Ω. m² for non-aggressive environments and
- >8 Ω. m² for aggressive environments.

For galvanized earth electrodes, the polarization resistance shall be

- >3 Ω. m² for nonaggressive environments and
- >7.6 Ω. m² for aggressive environments.

2. Maintenance and Measurements

2.1 Maintenance of Earthing

Introduction:

Earthing is the process of connecting the current carrying and non-current carrying metal parts of an electrical system to dissipate the currents to the ground during any abnormal conditions. Even though earthing plays an important role in ensuring the performance of machines and safety of the person, the maintenance of earthing system was not given the due importance which it actually deserves.

Maintenance of Earthing System:

However good a product could be, if not installed and maintained properly, it could affect the entire performance of the product. In order to ensure the proper operation of machineries, every industry schedule for preventive maintenance. Similar to the machines, earthing system also has to be inspected periodically.

The major components of earthing system are,

- 1) Earth Electrode
- 2) Back fill compound or Ground enhancing compound
- 3) Terminal connector

The area around the earth electrodes should be cleaned and accumulation of garbage around the earth pits should be avoided. The earth pits should be accessible and the details such as Earth pit reference number, Installation date, Earth Resistance value, Date on which the readings were taken and Due date shall be mentioned on each earth pit. All the details should be properly recorded and separate layout of the earthing system in the entire plant shall be maintained.



Figure 18. Improper maintenance of earth pits

The earth pit images shown above are the practical examples for the condition of earth pits. This kind of practices should be avoided and proper importance should be given to the maintenance of earthing system. Each earth pit should be accessible and proper labelling should be provided.



Figure 19. Earth pit with proper maintenance

Earth Electrode:

The earth electrodes are commonly made of copper and galvanized iron materials. Copper has good corrosion resistance property than galvanized iron but the cost is higher.

IS3043 clearly explains that the earth resistance value mainly depends on the soil resistivity and doesn't depend on the nature of material. Hence proper materials having good corrosion resistance property should be selected. The main problem with the earth electrode is, the corrosion rate depends on the nature of soil in that locality. Lower the soil resistivity in that locality, higher will be the corrosion rate. IS 3043 explains the relationship between the soil resistivity and corrosion rate and the details are attached below.

Soil Resistivity and Corrosion	
Range of Soil Resistivity (ohm-metre)	Class of Soil
Less than 25	Severely corrosive
25-50	Moderately corrosive
50-100	Mildly corrosive
Above 100	Very mildly corrosive

Table 20. Soil resistivity and corrosion

Since the electrodes are driven into the ground, they are directly exposed to the soil and moisture present in the soil. The corrosion rate of electrodes mainly depends on the salt and minerals present in the soil and we cannot specify a common life time for an electrode. Hence the condition of earth electrodes has to be periodically inspected to ensure their rigidity and other signs of deteriorations.



Figure 20. Quote about iron

We all are familiar with the above famous quote which compares iron with the personality. Even though the iron is very hard, its rust is capable of destroying it over a period of time. The earth electrodes are more prone to corrosion because of the availability of moisture and salts present in the soil.



Figure 21. Corroded earth electrodes

From the above images, we can observe that the earth electrodes that looks good above the ground surface might be completely corroded below the ground level. One of the solutions for preventing electrical accidents due to such damages is performing proper inspections periodically.

The condition of earth electrodes cannot be verified by visual inspection and hence, the earth resistance value can be used to examine the condition of earth pits. The earth resistance values measured during every inspection shall be documented and the difference of earth resistance values between the inspections should be carefully monitored.

Back Fill Compound or Earth Enhancing Compound:

Earth enhancing compounds are highly conductive compounds which are filled around the earth electrode by replacing the existing high resistance soil to provide low earth resistance value and improve the performance of earthing system.

The soil resistivity mainly depends on the moisture content of the soil. The neighboring soil to the earth electrode shall be kept moist, by periodically pouring water through a pipe where fitted along with it or by pouring water in the immediate vicinity of the earth electrode.

One of the main properties of back fill compound is, it should have the capacity to absorb and maintain moisture around the earth electrodes. Hence based on the property of the compound used for ground enhancing purpose, the time interval between the watering shall be determined. The material used should not catalyze the corrosion of earth electrode.

Terminal Connector:

The connection made on the earth electrode plays a major role in faster dissipation of the fault current. The following points shall be verified while inspecting the earth pits.

- The terminal clamps should be tightened properly.
- There should not be any loose connections in bolt & nuts, if any.
- There should not be any air gaps between the conductors.
- Contact of dissimilar materials should be avoided.
- Bolt & Nuts made of SS material is preferred because of its good corrosion resistance property.

The connections between the dissimilar materials can be made using bimetallic connectors to avoid galvanic corrosion. If the moisture content is high, then all bimetallic joints shall be encapsulated in a grease impregnated tape, mastic compound or bitumastic paint.

IS 3043 suggests that, the surface of the conductor should be cleaned thoroughly by wire brushing and an approved jointing compound applied immediately to both mating surfaces. Bolts should then be tightened and all excess grease or compound wiped off and discarded. To ensure adequate contact pressure and avoid overstressing, torque spanners should be used.

By avoiding the air gaps and proper tightening, the contact resistance between the earth conductor and earth electrode shall be reduced. Even though the earth electrode is in good condition and soil has sufficient moisture content, if the terminal connection is not proper, it affects the performance of the entire earthing system.

Any air gaps between the conductors and loose connections may lead to establishment of an electrical arc during fault conditions and the resistance of electric arc adds to the effective resistance of the earthing system. Hence the air gaps and loose connections should be checked with utmost care for better performance of the earthing system.

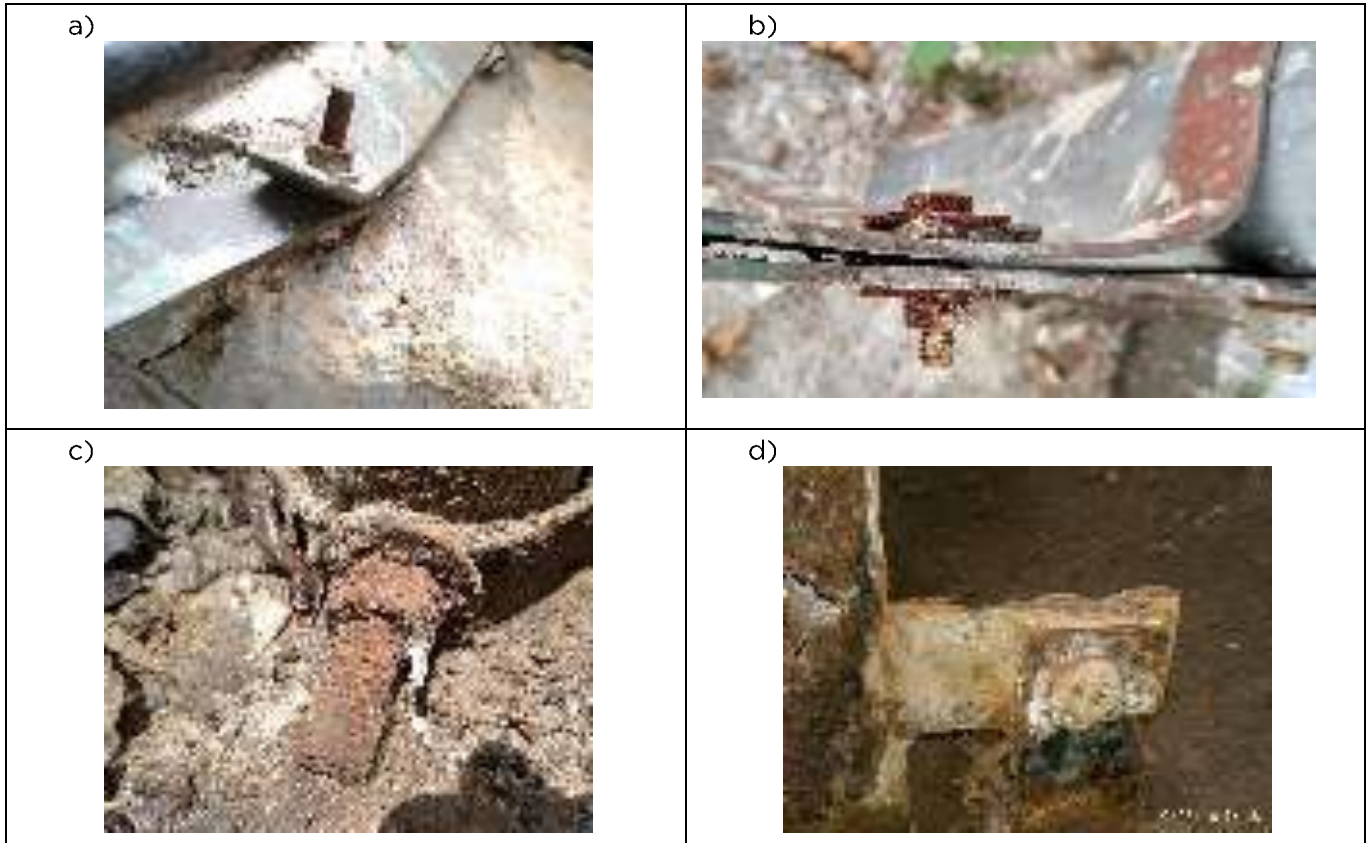

Figure 22. Corroded terminal connections and air gaps

The above images explain the effect of improper maintenance on terminal connections. The bolts & nuts should be disconnected and connected during every inspection and approved jointing compound shall be applied.

Conclusion:

The number of accidents and casualties due to electric shock is very high in India when compared with the other countries. Lack of awareness, electrical network knowledge and training among the operators about the destructive nature of electric current are some of the reasons for accidents in industries. Effective earthing system with sensitive earth fault protective devices may reduce the number of casualties due to such accidents. Proper awareness should be created among the professionals about the importance of maintenance of earthing system and earthing maintenance shall be scheduled similar to preventive maintenance schedule of machineries.

2.2 Measurement of Soil Resistivity

Introduction:

The earth resistivity extremely varies between (1 to 10,000) Ω .m and in most of the situation the soil resistivity found to be a non-uniform. The variation of soil resistivity with respect to depth will be higher than the variation in horizontal distance.

Measurement of earth resistivity at the sites reveals the characteristics of soil whether it is homogenous or non-uniform. The soil resistivity value mainly depends on the moisture content and hence it is advisable to perform the testing during dry season. The soil resistivity measurement procedures as mentioned by IS 3043 are as follows.

Test Location:

In substation or generating station, the measurement shall be made in at least eight test directions from the center of the station to cover the entire site.

For transmission line, the measurements shall be made along the direction of the line approximately once in every 4 kilometers.

Principle of Tests:

Wenner's four electrode method is widely used for measuring soil resistivity in site location.

In this method, four electrodes are driven in a straight line at a equal intervals into a earth. A current I is passed through the outer two electrodes and the voltage will be observed between inner two electrodes. The resistivity will be proportional to the ratio of the voltage to current accordingly.

Since the depth of burial of the electrodes is negligible compared to the spacing between the electrodes, then the simplified resistivity value provided by IS3043 is as follows.

$$\rho = \frac{2\pi sv}{I}$$

Four terminal earth resistance testers are commonly used for measuring soil resistivity, which comprises the current source and meter in a single instrument and directly read the resistance.

Modified equation for calculating the soil resistivity as specified by IS3043 is as follows.

$$\rho = 2\pi s^2 R$$

Where,

ρ = resistivity of the soil in Ω .m

s = distance between successive electrode in m,

R = Megger reading in Ω .

Test Procedure:

- As per Wenner's four-point method, four electrodes are driven in a straight line at equal intervals in the test site.
- Each electrode should be around (10 to 15)cm in depth.

- The earth resistance meter should be placed on the steady and level base and the four electrodes are connected to the meter terminals.
- The readings on the scale while rotating the crank at a speed of about 135rev/min are noted.
- The soil resistivity values are calculated by substituting in the equation to find out the soil resistivity.

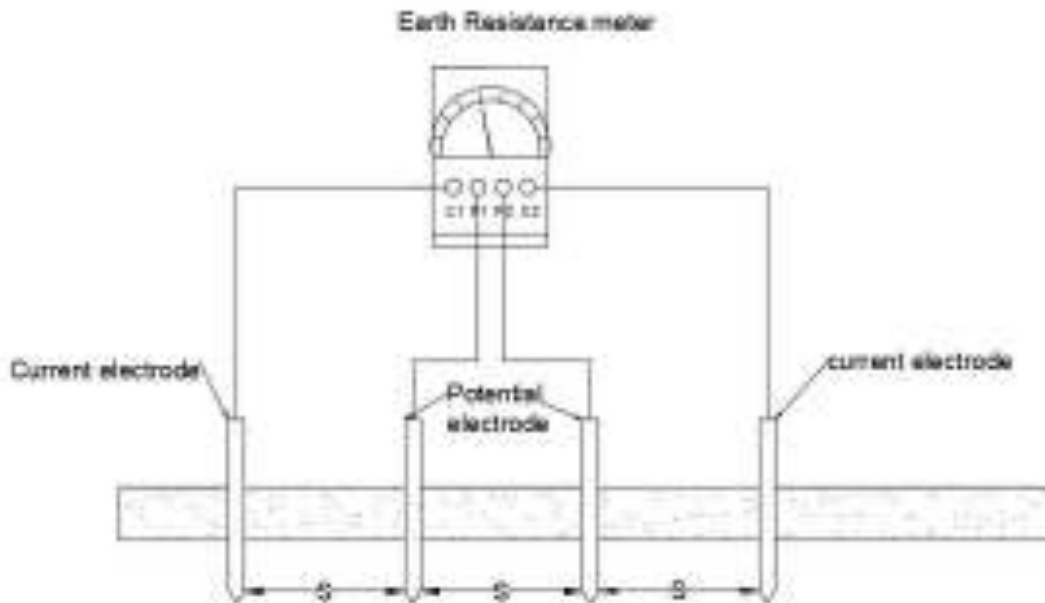

Figure 23. Four probe earth resistance meter connection

Correction of Potential Electrode Resistance:

If the resistance of the potential electrode is comparatively high, a correction of the test result would be necessary on its value. The connection for the measurement is shown below.

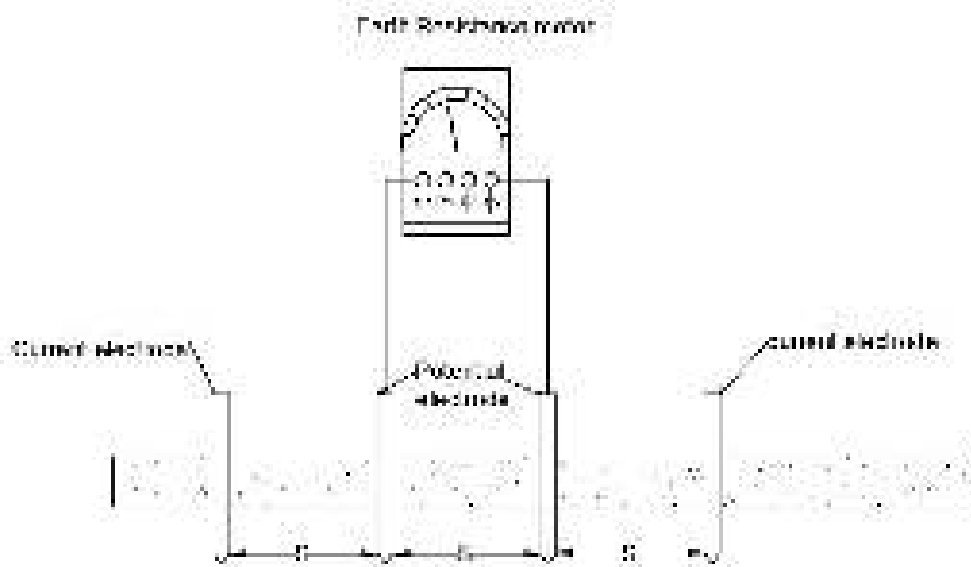

Figure 24. Connection for correction of potential electrode resistance

The corrected value of the earth resistivity shall be calculated by using the below formula.

$$\rho = \frac{\rho' * (R_v + R_p)}{R_v}$$

Where,

ρ = Corrected value of earth resistivity,

ρ' = Uncorrected value of soil resistivity,

R_p = Megger value for corrected connection.

R_v = Resistance of the voltage circuit of the instrument used to obtain R

A more scientific approach is to measure the earth resistivity in different radial directions from a central point which may be taken as the proposed load center. With the values so obtained, a polar curve is drawn. The polar curve is converted to an equivalent circle.

The procedure for finding the average resistivity using this approach is as follows,

- The resistivity is measured on at least eight directions from the Center of the site.
- This resistivity is plotted on a graph sheet in the appropriate directions.
- All the plotted resistivity points are joined to form a closed polar resistivity curve.
- The area inside the polar resistivity curve is measured.
- The equivalent circle having the same area of resistivity curve is found out.
- The radius of this equivalent circle is the average resistivity of the site under consideration.

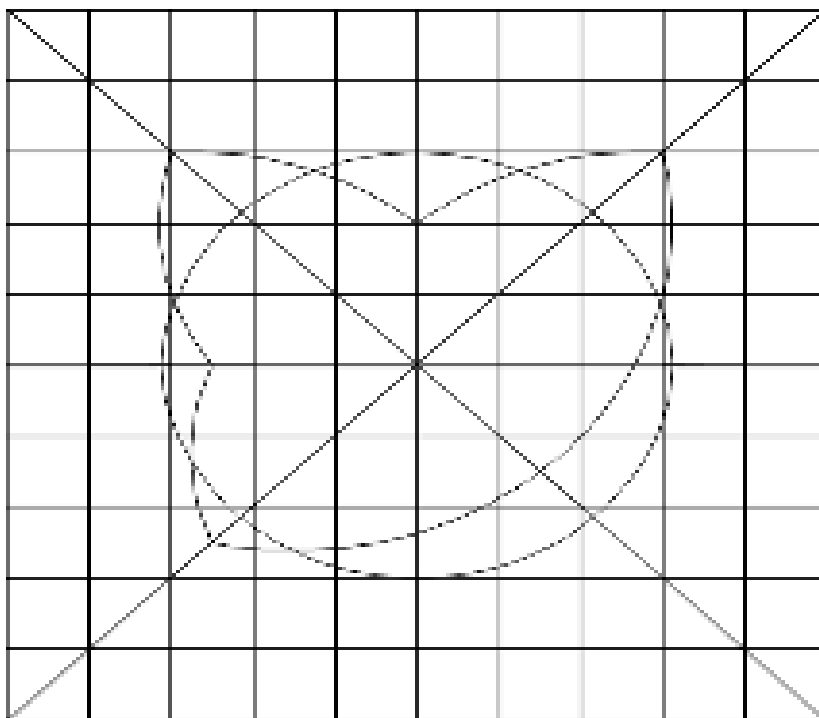

Figure 25. Measurement of soil resistivity

2.3 Measurement of Earth Electrode Resistance

Introduction:

For the proper functioning of the electrical system and the safety of the operating persons, it is essential to provide effective earthing. The complete earthing of a system includes proper design and installation. After completing the installation of earth electrodes in a site, it is always recommended to measure resistance between the electrode and the true earth.

The earthing resistance of an electrode depends on

1. Resistance of the electrode
2. Contact resistance between the electrode and the soil
3. Resistivity of the soil

In all practical purposes the resistance of electrode (Ohmic resistance) and contact resistance between the electrode and soil can be negligible since it has very small fractions of an ohm.

Measurement of Electrode resistance:

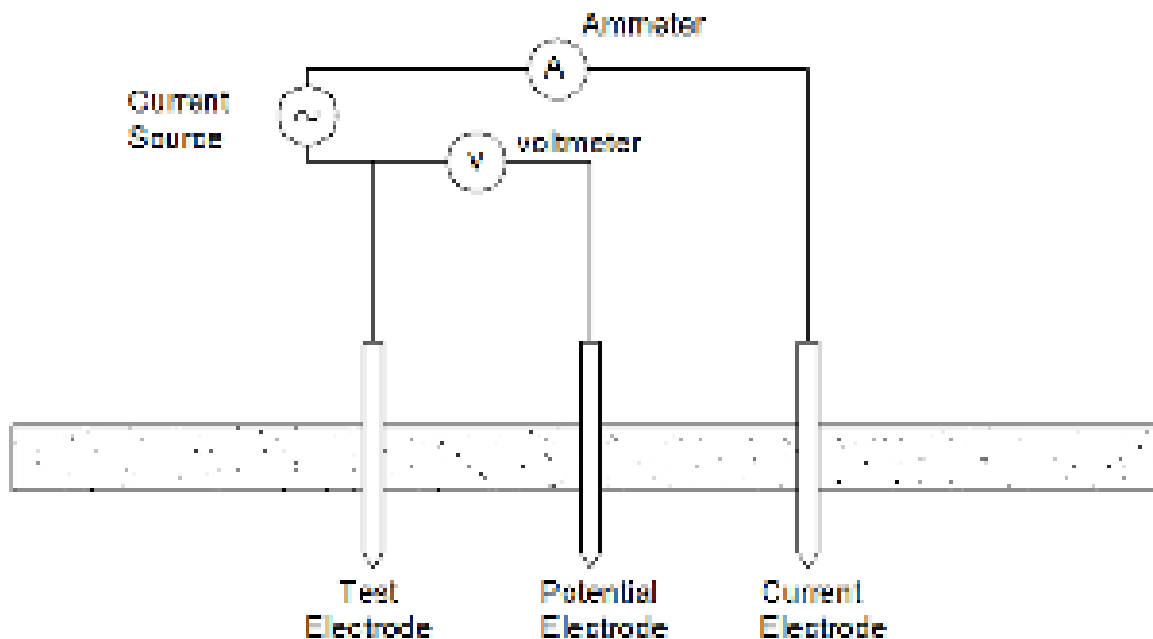

Figure 26. Measurement of earth electrode resistance

Three electrodes potentiostat method is used to determine the electrolytic resistance of a system. In this method there will be three electrodes.

- A - Test electrode,
- B - Potential electrode,
- C - Current electrode.

Current will be injected from current electrode and potential across the other two electrodes is measured. Based on the values of current injected and potential measured, the resistance value can be calculated by using the Ohm's law as shown below.

$$R = \frac{V}{I} \text{ Ohms}$$

R – Resistance of test electrode in Ohms

V – Reading of the voltmeter in Volts

I – Reading of the ammeter in Ampere

To measure electrolytic resistance IS 3043:2018 suggests following methods

1. Fall of potential 61.8 percent test
2. Fall of potential 61.8 percent test – Using clamp
3. Fall of potential - Slope test
4. Fall of potential - 90°/180° Test

Fall of potential 61.8 percent test:

IS 3043 suggests fall of potential 61.8 percent test to measure the earth electrode resistance for the small electrode system like LV installation and 11 kV ground mounted distribution substation and pole mounted transformer.

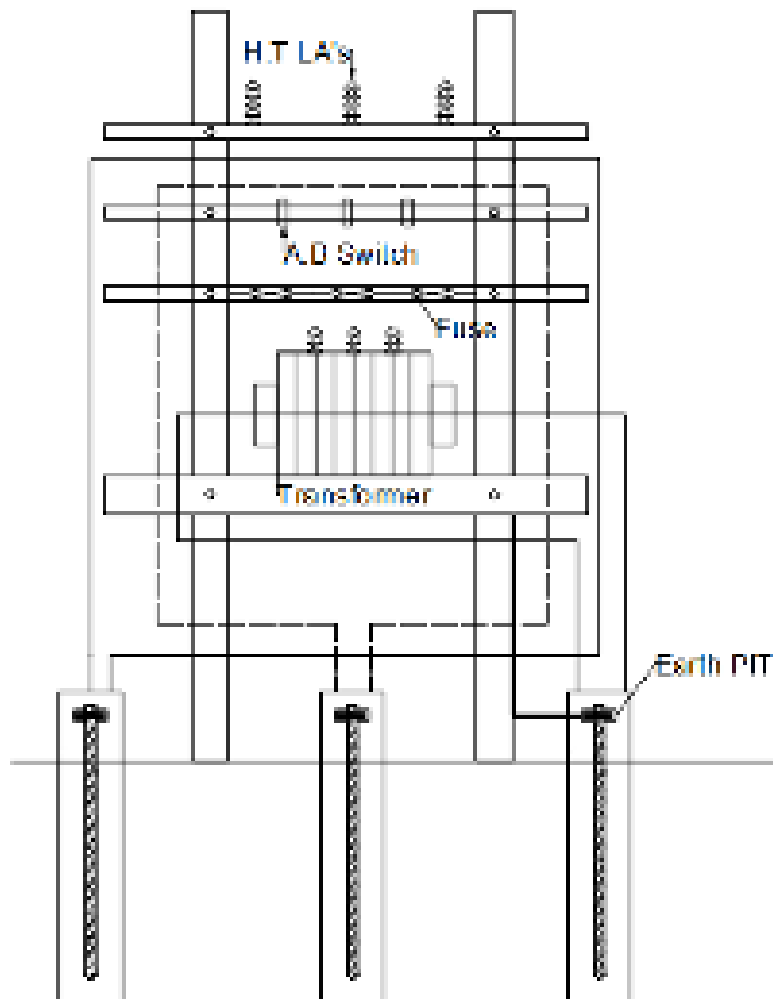

Figure 27. Ground mounted distribution substation

The ground mounted distribution substation comprises of pin type insulators, Air Break switch, lightning arrestor and distribution transformer. All those equipment's and their metal structures should be earthed properly in order to ensure safety of human beings and equipment. The ground mounted distribution station arrangement is shown below.

Measurement of Earth Electrode Resistance using 61.8 percent test:

In this method also three electrode potentiostat test procedure will be used but the positioning distance of probes should be changed. The current probe should be connected in straight line in order to achieve reliable readings.

The stray current flowing in the soil will produce serious errors in the measurement. To avoid this situation and to improve the accuracy, earth tester along with a hand driven generator is used. The presence of stray currents in the soil is indicated by the deflection of the instrument pointer, but an increase or decrease of generator handle speed will cause this to disappear.

Earth tester usually generates direct current (DC) and having rotary current reverser and synchronous rectifier mounted on generator shaft. So alternating current (AC) is supplied to the test circuit. The resultant potential is again rectified for measurement by a direct reading in moving coil ohm meter.

IS 3043 suggests that for small earth electrode system the distance between earth grid and current probe should be 50 m and the voltage electrode shall be placed at 61.8% of 50m which is 31m. The measurement arrangement is shown above.

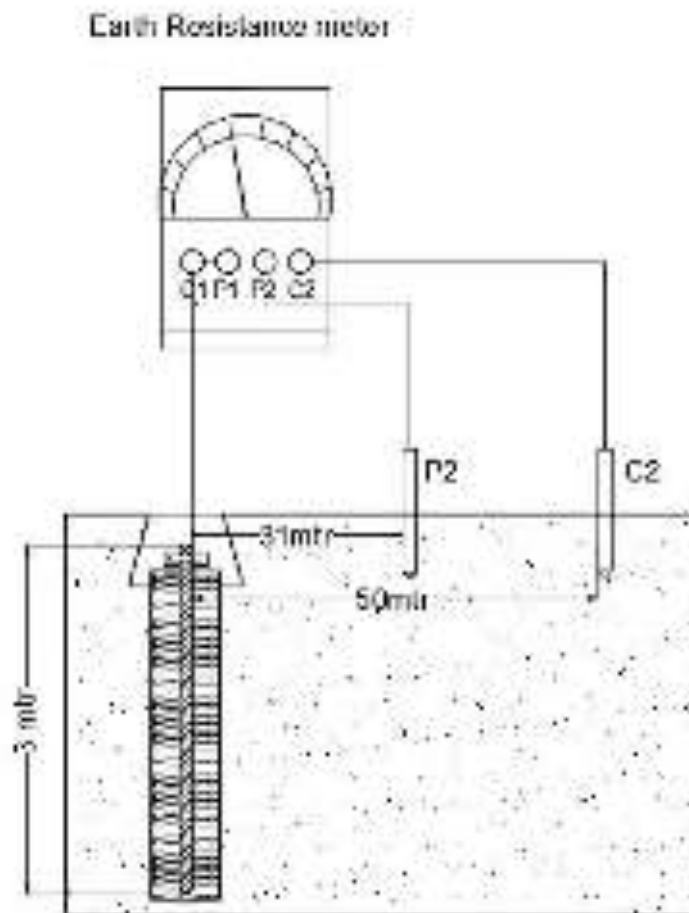

Figure 28. Fall of potential - 61.8% method

The distances should be increased when the earth electrode system having medium size of electrode. In order to confirm the accuracy, the voltage probe shall be moved to 50% percent and 70% of current probe distance and the corresponding readings are also tabulated.

If the earth electrode resistance of an individual earth electrode needs to be measured without disconnecting it from the earthing network, instruments with CT clamp tester shall be used. The CT will detect the current returning through that particular earth electrode.

Fall of potential – Slope Method:

In substations, the earth grid will be larger in size and placing the current probe beyond the influence of the electric field of electrode in the soil will be very difficult. The slope method is suitable for such applications and it is used to find where the resistance of the earth electrode maximises.

In this method the position of the potential probe is adjusted and the readings are noted at three different positions as 0.2, 0.4 and 0.6 times the distance to the current probe and the values be R_1 , R_2 and R_3 respectively.

The rate of change of slope can be calculated by using the below formula,

$$\mu = \frac{R_3 - R_2}{R_2 - R_1}$$

90°/180° Test:

This method is used along with either slope method or 61.8 percent method to verify the result. The voltage probe P2 will be placed at an angle between 90° to 180° to the current probe. The tests are performed at different positions of voltage probe like 20%, 40% & 60% of the distance of the current probe distance.

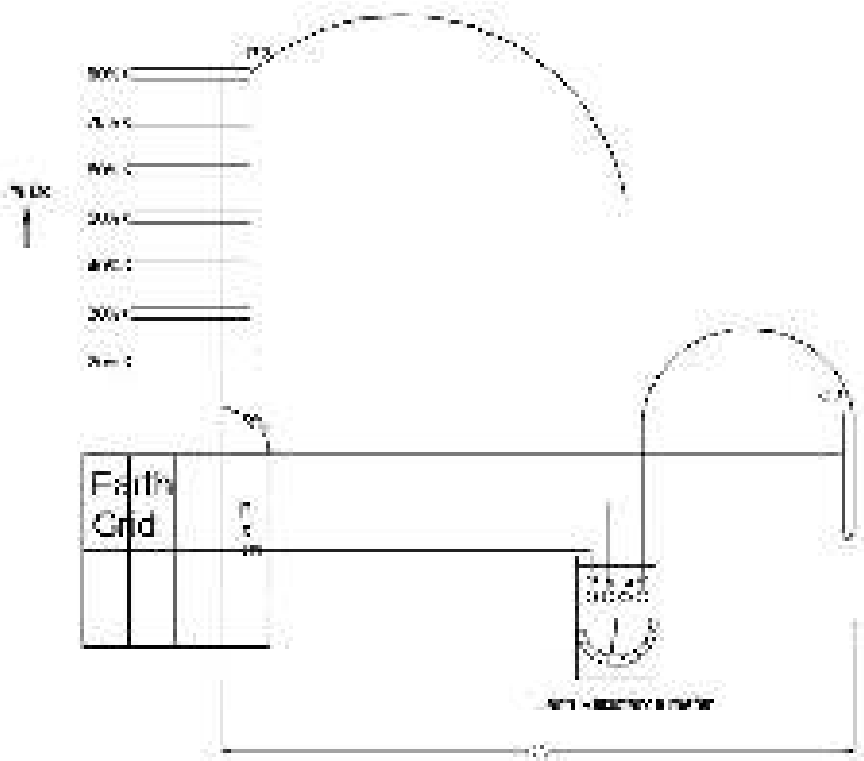

Figure 29. Fall of potential - 90°/180° test

3. Applications

3.1 Earthing In Substation

Introduction:

Earthing is the process of connecting the current carrying and non-current carrying metal parts of an electrical system to dissipate the currents to the ground. Substations are one of the major parts of electrical network. Any abnormality in substation will lead to isolation of all the areas which are under the control of that substation. IS 3043 explains the earthing procedures for substations and some of its recommendations will be discussed below in this article.

Earthing in Substations

The electrical energy from the power plants are stepped up to extremely high voltage levels and transferred through the transmission lines. These high voltages are stepped down in various levels before reaching the end user. The stepping up and stepping down of voltages at different levels of transmission and distribution are done at the sub stations. Transformers, Circuit Breakers, Isolators, CT, PT, Lightning Arrestors, and many protective components are used for this process.



Figure 30. Substation

Any electrical network is an extraordinarily complex network and the transmission lines run across the country to interconnect the remote villages with the network. The stability of electrical network is continuously monitored from these stations and necessary actions are taken during any abnormalities.

The transmission lines are more prone to voltage surges due to both switching operations on lines and lightning strikes. These surges should be properly diverted to earth as soon as possible for protecting the components in substation.

The magnitude of fault current in substation during ground fault will be extremely high and hence proper earthing system with low resistance value should be designed to dissipate the fault current as soon as possible.

The neutral of the transformers will also be earthed at the substations. The ground voltage acts as the reference for system voltage. The ground potential rise in substations during the faults will be of extremely dangerous levels and it can cause electrocution even without any direct physical contact with any equipment.

In general, earthing in substations are needed for:

- Earthing the neutral points of the system.
- Earthing the non-current carrying metalwork associated with the electrical system like metal structures, transformer tanks, power cable sheaths.
- Earthing the metal structures that are not associated with the power systems like boundary fences, sheaths of control or communication cables.

The earth system should also remain effective throughout the life of the plant. The conductors selected for grounding and bonding in substations should have adequate current carrying capacity and should be able to dissipate the currents without any damage.

On high voltage systems with directly earthed neutrals, potential of earthed metal parts during the passage of high magnitude earth fault currents will not be near true earth potential. The entire ground potential will get shifted due to the ground potential rise at abnormal conditions. The rise of potential of an earthing installation during abnormal conditions should be maintained as low as possible since this potential will be applied across the telephone cables or cable sheaths through the common earthing.

If surge protection devices are provided, then the connection to the earthing system from the device should be made as direct as possible.

Recommendations for Neutral Earthing:

If the neutral points of two electrical systems which are electrically isolated are connected to a common earth electrode system, there will be a coupling of the systems through the earth electrode system due to the passage of the fault current during the abnormal conditions.



Figure 31. Transformer earthing

If we need complete isolation of electrical systems, then the neutral points of each system have to be separately earthed. In this case each earthing system should be insulated from each other. The insulation should be capable of withstanding the maximum rise of earth potential during the discharge of lightning impulse currents or power system fault currents but providing insulations to this level is rarely practicable.

The choice of providing either a common earthing system or separate earthing system for the systems having different voltages at the substation affects the following:

- The breakdown in a transformer between the higher and lower voltage sides due to lightning or other surges.
- The safety of consumers or their property supplied from the substation.

The former risk of breakdown can be reduced by using a common earthing system, and the latter danger can be reduced by providing earth electrode system having very low earth resistance value capable of limiting the rise of earth potential to a safe value. The advantage of using a common earthing system is that the overall earth electrode resistance will be very less due to parallel earth electrode resistance.

The rise of substation earth potential will not be excessive if the resistance of the earth electrode system is small compared to the total earth fault circuit impedance.

The neutral will be directly earthed for high voltage systems (66 kV and above), to reduce the costs of insulation that would be required for the transformer winding.

Earth Electrodes

The main objective of earthing is to ensure that the voltage appearing on the accessible equipment or structures should be below the tolerable level. The earth electrodes used in substation shall have the following characteristics.

- It should have low earth resistance under all climatic conditions.
- It should have the current carrying capability during fault or surge discharge conditions
- It should be located as short and straight as possible to minimize surge impedance.
- It should be made of materials having good corrosion resistance property.

For high voltage system earthing, special precautions are necessary to restrict the rise of ground potential within safe value.

For lower current rating requirements, earth electrodes in the form of rods are usually preferred and rods made of copper-clad steel shall be used. If we are using multiple earth electrodes in parallel connection, then the spacing between the electrodes should be greater than the length of the electrodes. Earth electrodes in the form of Plates and Pipes are also commonly used for substation earthing.

For large substations, earth strips in the form of mesh are laid below the ground level. The system neutral and structure body will be connected to this earth mesh. It provides an equipotential surface over the substation and the earth strip should have sufficient current carrying capacity. This earth mat should be designed by considering the tolerable step and touch potential limits.

Recommendations

- The earthing system must be robust.
- All the joints should be capable of retaining low resistance after passages of fault current for multiple times.
- The cross-sectional area of conductors should be calculated by considering the maximum magnitude and the corresponding duration of the fault current. Generally, one second for voltages above 33 kV and 3 seconds for lower voltages are considered for designing.
- The reinforcement in foundations can also be used to provide an effective earthing system.
- Copper earth strip in contact with galvanized steel should be tinned to prevent electrolytic action.
- Aluminum should only be used above ground and bimetallic joints shall be used for connections to earth electrodes.
- If aluminum has to be used below ground level, then it should be protected against contact with soil and moisture.
- All crossings of conductors in the main earth grid should be welded.
- The conductors used for earthing should be laid below the ground level at a depth of 600mm.

3.2 Earthing Associated with Overhead Power Lines

Introduction:

Earthing is one of the important components of a transmission network. The overhead power lines are supported by the towers of required dimensions at regular intervals. These transmission lines run across the country and are exposed to the adverse climatic conditions. Hence the chance of these supporting towers become live due to any faults or due to direct lightning strikes are much higher.

In general, these supporting towers or poles are made of different materials like metal, wood, concrete & glass reinforced plastics.

Following an insulation failure, a voltage may exist between any supporting metalwork and earth. The public are generally protected if no metalwork within 3 m of the ground is liable to become live on failure of insulation. Where a pole is of non-conducting material, for example wood or glass-reinforced plastics; the pole will act against the flow of leakage current and can be expected to prevent danger near ground level due to leakage across or failure of any insulator supporting a line conductor.

When a lightning strikes a transmission tower, the over voltage might cause stress on the insulators, the transmission lines and other components of the Tower. So it is essential to properly ground the tower by methods like using earthing electrodes of rod / pipe, burying the conductor, using counterpoise wires.

Lattice Steel Structures

The lattice steel structures are generally earthed through the contact of their foundations with the ground.



Figure 32. Lattice steel structures of overhead power lines

When the earth resistance at the foot of a tower (known as Tower footing resistance) is very high, counterpoise earthing shall be done in order to reduce the earth resistance to enhance the faster dissipation of the fault current.

Counterpoise earthing consists of four lengths of galvanized steel wires mostly and they are taken radially out from the tower foot and buried horizontally into the earth.

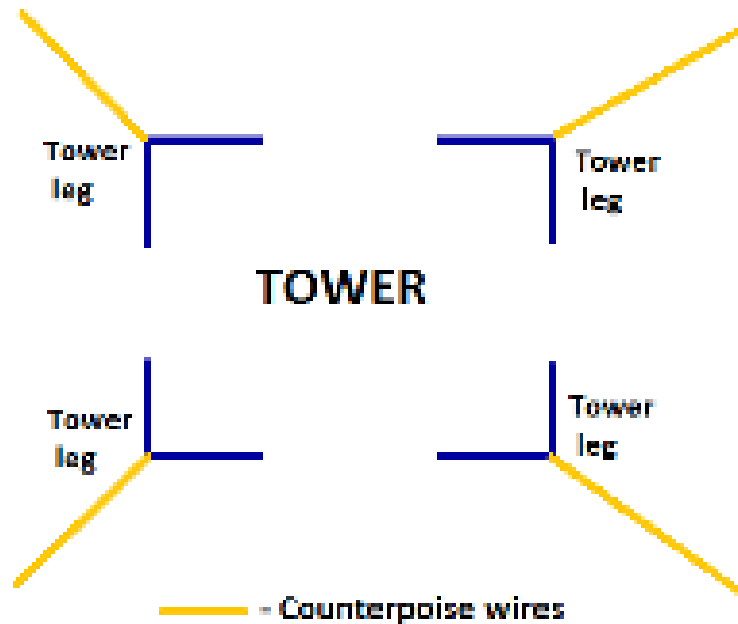

Figure 33. Counterpoise earthing

In major cases, a wire or strip of length at least 25 m is buried horizontally at depth of 0.5 m below ground and the length of the wire shall substantially be increased if the resistance value is still high.

In the transmission lines, earthing or shielding conductor will be laid at the top of the line conductors. These conductors will be earthed at every tower and it also provides protection against the lightning strikes.

Lightning Protection:

The transmission towers are directly exposed to the atmosphere and in many places these metallic structures will be taller than the other structures or objects in their surroundings. Hence these transmission towers and the conductors are more prone to lightning strikes. The earthing conductor attached to the top of a structure reduces the likelihood of a lightning strike on the tower and lines. These conductors act as a shield and protect the live conductors being struck by lightning strikes.

The lower the impedance between aerial earth-wire and earth, the better is the protection since this reduces the possibility of a back flashover from the earthed metalwork to line conductors on the occasion of a direct strike to the earth wire.



Figure 34. Shield or earth wires in transmission lines

Earth Wires and Earth Connection:

- Any connection between metal work and earth has to be of low resistivity, both to provide for prompt operation of protective equipment and to minimize inductive interference with communications circuits in the event of a flow of fault current.
- Any metal bracket supporting a phase conductor needs to be earthed unless the conductor is both insulated and supported by an insulator.
- Stay insulators should be installed on the stay wires to prevent the corrosion due to passage of small leakage currents.

3.3 Earthing for Industrial Protection

Introduction:

In recent, years, the number of electrical accidents in industries are increasing every year and hence the need for the use of ground fault protection in industrial distribution circuits is also increasing. These accidents explain the need for better ground fault protection and to examine the grounding practices in the light of the required protection. But the earthing system is not given the importance it deserves in most cases.

From the point of view of safety, it is equally important that earthing should ensure efficient and fast operation of protective gear in the case of earth faults. Adequate co-ordination between the practically obtainable value of the earth resistance and setting of the protective relays should be achieved. In this article, we shall explore about the recommendations for earthing and earth Fault protection provided by IS 3043.

Earthing of Industrial Premises:

The design of earthing system for any scheme is developed on the basis of basic requirements. The earthing system for industries should be so designed such that the ground potential rise during any fault is kept below the tolerable limit. The size of the earthing conductor should be selected in such a way that they have the capacity to withstand the fault current any physical damages due to heating and without much temperature rise for the specified period.

Optimum value of the earth resistance should be achieved depending upon the setting of the earth fault/earth leakage relays. For areas having abnormally high earth resistivity values, adequate co-ordination between the practically obtainable value of the earth resistance and setting of the protective relays should be achieved.

Earth Electrode:

Earth electrodes should be designed by considering not only the fault current withstanding capacity but also the appropriate thermal withstand capacity.

The main criterion is that the value of the earth resistance should not be so high. If the resistance of the earthing circuit is higher it limits the fault current and it may not be sufficient for actuating the protective devices within the stipulated time. Hence, multiple earth electrodes shall be connected in parallel to obtain the desired lower earth resistance values required for the proper operation of the protective system.



Figure 35. Multiple earth electrodes in parallel connection

The neutral of the transformer shall be connected to an earth electrode or multiple earth electrodes in parallel connection. In the case of separate earthing for transformer neutral, the total fault current will be dissipated through the earth electrodes alone. But in the case of a protective multiple earthing system where the neutral of the transformer and the non-current carrying metal parts are interconnected by the common earth grid, the total earth fault current enters the earth through different earth electrodes.

Earthing and Earth Fault Protection:

Protection against electric shock can be achieved by automatic disconnection of supply during the fault conditions. Automatic disconnection is intended to prevent a touch voltage persisting for such time that a danger could arise. This method necessitates co-ordination of

- The type of system earthing.
- Characteristics of protective devices.

Distribution circuits which are solidly grounded or grounded through low impedances require fast clearing of ground faults. This involves high sensitivity in detecting low ground fault currents as well as the co-ordination between main and feeder circuit protective devices.

In high voltage applications, there exists a risk of electric arc establishment between the contacts during the disconnection of supply. Special care should be given for such cases and fault clearing must be extremely fast where arcing is present.

Protective devices have usually fuse switches or circuit breakers with integrally mounted phase tripping devices. These protective devices carry the current in each phase and clear the circuit only when the current reaches a magnitude greater than full load current. Hence, these devices are termed as overload or fault overcurrent devices.

To accommodate inrush currents such as motor starting or transformer magnetizing inrush, these over current devices are designed with inverse characteristics, which are rather slow at overcurrent values up to about 5 times rating.

Correlation between Earthing and Earth Fault Protection:

The ground fault current depends upon the impedance to zero sequence current flows and depends to a large extent on the grounding network and the earth resistivity. The pickup value of the ground fault relays or the value of the phase fault protective device should be coordinated for the required protection for the system.

Optimum value of the earth resistance should be achieved depending upon the setting of the earth fault/earth leakage relays. For areas having abnormally high earth resistivity values, adequate co-ordination between the practically obtainable value of the earth resistance and setting of the protective relays should be achieved.

The earth grid design is closely related to the effectiveness of the phase fault protective device in clearing a ground fault in place where separate ground fault protective devices are not provided. In case the impedance of the earth return path cannot be regulated so as to produce adequate fault current for operating the protective devices like fuses, such circuits should be protected by separate ground fault protective devices. Hence, the necessity of separate ground fault protection depends on the grounding network and its effective impedance.

3.4 Earthing of Conductor for Safe Working

Introduction:

One of the main objectives of providing earthing is to ensure the safety of equipment and operating person. The number of injuries and deaths in industries due to electrical shock in India is very high when compared with the numbers of developed countries. Lack of electrical network knowledge, awareness and training among the operators about the destructive nature of electric current is one of the reasons for accidents in industries. The energy stored in cables even after disconnecting from the supply itself can harm the operating person. Hence proper precautionary step should be taken before doing maintenance works in the industries.

To ensure a safe system of work, a set of detailed rules and procedures will be necessary in each particular case. IS 3043 explains the earthing procedures to be followed for ensuring the safety of operating person in the working place.

Safety Earthing:

Electrical network is a complex network and hence special care should be taken on disconnecting the machines from all the sources of supply. Even though the equipment is disconnected from the power supply some energy will be stored on the cables and capacitors in the circuit. Hence these should be discharged to the earth prior to the works.

The safe work place can be ensured by following all the preventive measures which includes isolation, locking off, permits to work or similar documents.

When maintenance or repair work is to be carried out, the following precautions on safety earthing shall be followed.

- All live conductors should be isolated and should remain earthed until work is completed. The isolation from the supply should be verified before connecting to the earth.
- Either permanent or temporary earthing shall be provided at the time of work as safety earthing equipment. If the permanent earth electrode is not readily available then earth spike of required cross sectional area and length shall be driven directly into the ground and it can be utilized to provide temporary earthing.
- All equipment should be maintained properly and inspected before use.
- Earthing leads should have adequate cross-sectional area to withstand the fault current levels at the working location.
- The cross-sectional area of the earthing lead at any case shall not be less than 6 mm².
- Earthing leads should be efficiently bolted or clamped to the earthing system and then connected to the apparatus to be worked on.
- Once the work is completed, the connections from apparatus should be removed in all cases before disconnecting from the earthing system.
- An insulated earthing pole or device should be used for applying the earthing leads to the apparatus on which work is to be done.
- Earthing leads should be as short as and it should not be disconnected or disturbed accidentally while the work is under progress.

Precautions Relating to Apparatus and Cables:

Even though the machines are isolated from the supply, some amount of energy will be stored in the form of electric field and magnetic field. Inductors store electrical energy in the form of magnetic field and capacitors store electrical energy in the form of electrical field.

The capacitance value of multicore cables will be very high and hence there will be some amount of energy stored in the cables due to the capacitance. When work is to be carried out on such equipment (Ex. cables and capacitors), the stored energy has to be discharged to earth prior to work and the equipment should remain earthed while the work is in progress.

In the case of switchgear, all the line conductors should be short circuited and earthed to the same earthing system.

In the case of transformers, the terminals of all windings should be earthed so that no danger from shock can occur and any winding becoming inadvertently live can be avoided.

When the neutral points of several transformers are connected to a common bar, and the common bar is earthed through an arc suppression coil, the neutral point of the particular transformer that is to be worked on should be disconnected and directly earthed along with the phase conductors.

Precautions Relating to Overhead Lines:

The transmission network is a very complex circuit and hence proper precautionary measures should be taken before starting the work.

The section of the transmission line should be isolated from the power supply and all the line conductors should be short circuited and connected to earth.

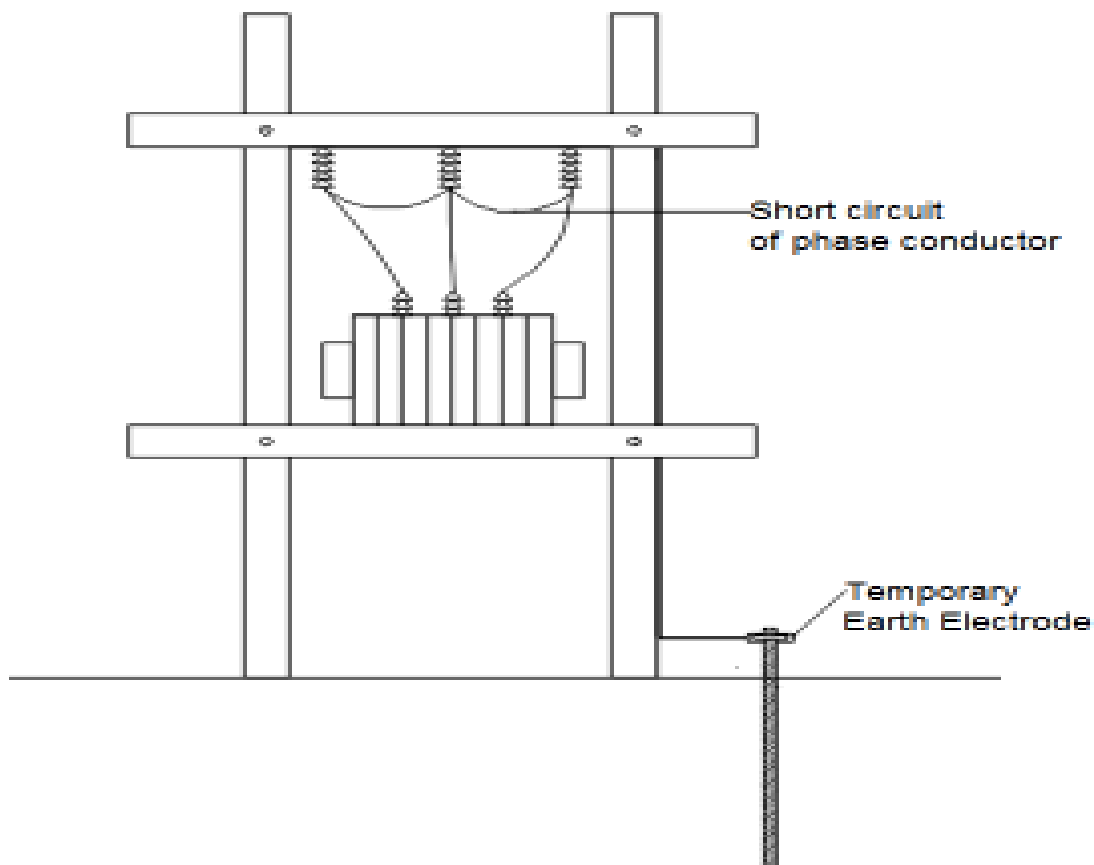

Figure 36. Safety earthing for overhead lines

- The section of line should be made dead by isolating from the power supply.
- All the three phase conductors should be short circuited and earthed.
- If permanent earthing is not readily available, temporary earthing of required cross sectional area shall be installed.
- Even though the transmission line segment is isolated from power supply local earthing at the point of work should be made to protect from the induction due to power supply in other lines and due to lightning.
- The connection of the earthing lead to each conductor of the overhead line should be made using a suitable mechanical clamp. The proper tightness of the connection with the lines should be ensured. The clamp should be supported by an insulated earthing pole.
- While working on the transmission line poles, it is necessary to provide a working earth on both sides of the working point.

3.5 Earthing Recommendations for Hazardous Area

Introduction:

Earthing of system is designed primarily to preserve the security of the system by ensuring that the potential on each conductor is restricted to such a value as is consistent with the level of insulation applied. From the point of view of safety, it is equally important that earthing should ensure efficient and fast operation of protective gear in the case of earth faults.

Where flammable materials are used, processed or stored, earthing systems may be needed to reduce the danger from potentials which may arise due to leakage currents, which may be induced by operating current, or are due to man-made or naturally occurring static electricity. IS 3043 recommends the following earthing practices for such potentially hazardous areas.

Recommendations for Potentially Hazardous areas:

- All the connections between the metal parts and the earthing conductors should be tightened properly.
- The grounding conductors shall be selected by calculating the current carrying capacity of the material on hazardous conditions. The increase in temperature during the flow of current shall be within the permissible limit on that particular location.
- All the interconnections of equipment earthing to the earthing system for equipotential bonding should be made below ground.
- Efficient bonding should be installed for providing protection against the stray currents and electrostatic charges.

Earthing and Bonding of Pipelines in Hazardous Area:

- All the utility and process pipelines should be connected to the earthing system at a point where the pipelines enter or leave the hazardous area.
- Before connecting to the earthing, the provision of cathodic protection should be checked and exception can be provided for such cases.
- The steel pipe racks in the process units and off-site areas should be grounded at every 25 m.

Guidance for hazardous areas:

IS 3043 provides guidance on permissible power systems for hazardous areas and the details are as follows.

- An earthing system having combined neutral and protective earthing in a single conductor throughout the system (Indian TN-C) is not allowed in hazardous area. Hence for systems with earthed neutral, the TN-S system which uses separate conductor for neutral and protective conductor is preferred.
- The power system of type TT is not permitted in Zone 0.
- If a power system having separate earthing for power system and exposed conductive parts (IT Type) is used in Zone 1, a residual current device should be installed even if the voltage is below 50 V.

- For a system with either neutral isolated from earth or earthed through impedance (IT system), an insulation monitoring device should be used to indicate the first earth fault. However, equipment in Zone 0 shall be disconnected instantaneously in case of the first earth fault, either by the monitoring and duration.
- For zone 0, instantaneous earth fault protection shall be installed at all voltage levels of power system.
- For zone 1, instantaneous earth fault protection devices shall be installed for certain applications.

Potential Equalization:

Potential equalization can be achieved in hazardous areas by equipotential bonding of all the exposed metallic structures and pipes to avoid the dangerous sparking between the metal parts. IS 3043 provides the following recommendations for hazardous areas.

- Equipotential is always required for all the installations in Zone 0 and Zone 1 areas. Hence all the exposed and extraneous conductive parts shall be connected to the equipotential bonding system.
- The bonding system includes protective conductors, conduits, metal cable sheaths and other metallic parts of structures except neutral conductors.
- The cross-sectional area of the conductors used for connecting the metallic parts should be at least 10 mm² of copper.
- Enclosures which are in direct contact with structural parts connected to the equipotential bonding need not to be separately connected to the equipotential bonding.

3.6 Earthing in Mines and Quarries

Introduction:

The main purpose of earthing in mines and quarries is to prevent the danger resulting from a rise in potential (above earth) on these conductive parts.

The presence of flammable gas and explosive materials in some mines and quarries increases the hazard in that location and hence proper earthing has to be provided to avoid the accidents due to sparking and increase in temperature of the earthing conductors as well. In these kind of sites, separate local earthing should be installed to avoid incentive sparks caused by static electrical discharge.

IS3043 has provided some guidelines for the earthing in mines and quarries and the details are as follows.



Figure 37. Mines and quarries

Earthing in Mines and Quarries:

At most mines and quarries, the incoming supply is provided by the supply authority through a transformer on the site. In this case, a connection of the consumer's earthing system to the neutral or mid voltage point should be made after getting approval from the supplier.

If the consumer generates electricity privately then the consumer should provide and maintain the earth electrodes that have the neutral or mid voltage points bonded to them.

If the supply transformer (or generator) is distant from the consumer's premises then the earth terminal should be made available by means of an additional earth conductor in the supply cable or overhead line.

If the provision of such an earth terminal is impracticable, then the earth electrodes at the supply source and consumers premises should be installed and maintained properly. The earth

electrode resistance value should be maintained as low as possible, for example, earth electrode resistance values of less than 2Ω shall be maintained along with the appropriate earth fault protection system. However, equipotential bonding of all the exposed metallic parts back to the supply source neutral or mid-voltage point earth electrode should be maintained.

No switch or circuit-breaker or fuse should be placed in any earthing conductor and interlocked changeover links shall be used in some cases. Such a device would be used to allow periodic testing of an electrode resistance to the general mass of Earth.

All the metallic covering of the cable should be earthed. Cables with steel tape armour, aluminium armour or copper sheathed cables are not suitable below the ground level. Paper insulated lead covered cable are not suitable for mines because of its lower mechanical strength. Generally single or double steel wire armoured cables are used for mines and quarries sites.

3.7 Earthing System for Medical Establishments

Introduction:

IS3043:2018 under Clause 11.1 explains about the different types of system earthing. Based on the earthing conductor and the location of earthing the electrical system can be classified as,

- TN System,
- TT System and
- IT System.

TN system

In the TN system, one or more points of the source will be directly earthed, and the other conductive parts of the installation are connected to the earthing of the source by means of protective conductors.

These protective conductors form a metallic path for earth fault currents to flow from the installation to the earthed point(s) of the source. TN systems are further sub-divided into three types as follows.

- TN-C systems,
- TN-S systems and
- TN-C-S systems.

TT system

In the TT system, one or more points of the source will be directly earthed and the other conductive parts of the installation are connected to the local earth electrode or electrodes. These local earth electrodes are electrically independent of the source earth.

IT system

In the IT system, the source will be either unearthed or earthed through high impedance and the other conductive parts of the installation are connected to electrically independent earth electrodes. Because of the earthing impedance, the fault current will be lower during occurrence of the single fault to exposed conductive parts or to earth. Disconnection of the supply is not required on the occurrence of the first fault.

Each system of earthing has its own advantages and limitations. Unearthed systems are also preferred for some application and we have already explained about the choice of selecting earthed system or unearthed system in our 3rd article – 1.3 Earthed or Unearthed System.

Earthing System for Medical Establishments:

In medical establishments, an error of very small margin will result in the loss of patient's life. The recommendations provided by IS3043 regarding the earthing for such highly critical medical establishments are as follows.

- The electrical installations used in medical establishments should be reliable and safe. It should not trip immediately after the occurrence of first instance of fault.

- The risk of electric shock has to be minimal.

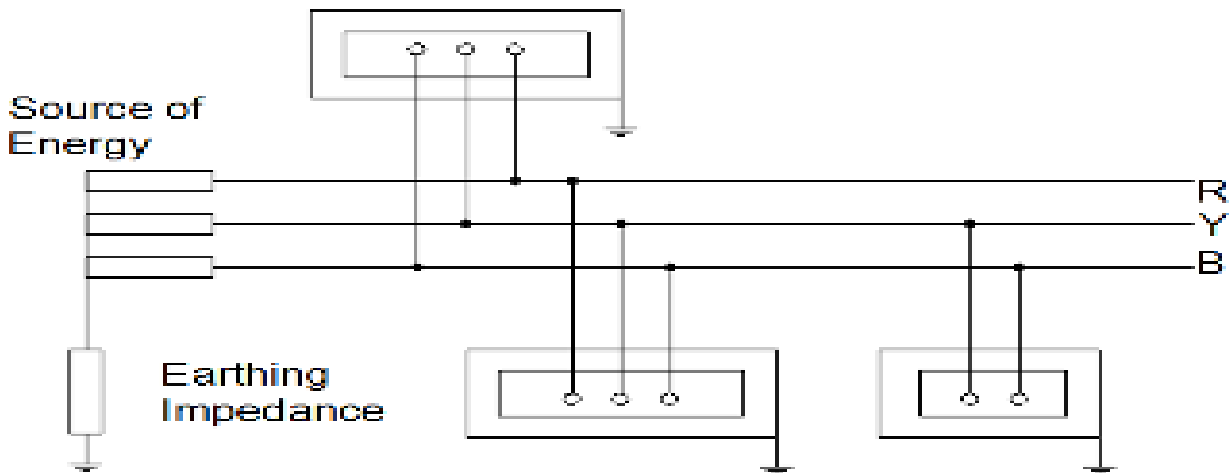

Figure 38. IT system

The Risk for patients in medical locale is increased due to:

- The Reduction in body resistance, since the skin is often cut or damaged or their defensive capacity is further reduced by applying medication or nullified while anaesthetized.
- These conditions may increase the possible consequence of an electric shock under fault condition.
- Interrupted power supply to certain equipment's may causes threat to human life in case of any serious fault situation occurs.

Advantage of using Medical IT System:

- Reliability of the IT system is much higher and it is most suitable for places where the interruption of supply will result in loss of patient's life.
- In a medical IT-System the earth fault current will be low value and the touch voltage across a protective conductor is also reduced;
- The leakage currents of equipment in a medical IT-System is low.

The impedance to earth value of a medical IT-System should be maintained as high as possible. Since the primary reason for choosing the IT system for a medical establishment is the reliability of power supply, a dedicated insulation resistance monitoring system should be used and the values should be verified periodically.

An insulation monitoring device shall be installed to detect the live part to earth insulation in a medical IT system. The ac resistance value of an insulation resistance monitoring device should be greater than 100k Ω . This device is set to operate an alarm if the insulation resistance value between the isolated circuit and the earth reduces below 50k Ω . IS 3043 recommends to keep this threshold value as high as possible.

3.8 Earthing for External Lightning Protection

Introduction:

Lightning is a natural phenomenon of sudden discharge of charges from highly charged clouds. The main and most effective measure for protection of structures against physical damage is considered to be the lightning protection system (LPS). An external Lightning Protection System is intended to

- Intercept a lightning flash to a structure. (Air terminal system)
- Conduct the lightning current safely towards the earth. (Down conductor system)
- Disperse the lightning current into the earth. (Earthing system)

Earth Termination system:

Earth termination system dissipates the lightning impulse current into the earth without much increase in the ground potential. IS/IEC 62305 suggests that a low earthing resistance value of less than 10 ohms is recommended for lightning protection system and a single integrated earth termination system comprising of earthing for lightning protection, power systems and telecommunication systems is preferable for all the applications.

As per IS/IEC 62305, there are 2 types of earth arrangements for lightning protection and the details are as follows.

- Type A arrangement
- Type B arrangement

Apart from these two methods, NFC 17-102 proposes one more earthing arrangement which is generally called as Goose Foot Earthing arrangement.

Type – A arrangement:

This type of arrangement consists of earth electrodes in both horizontal and vertical earth electrodes connected to each down conductor. In this method the earthing arrangement won't form a closed loop. The total number of earth electrodes in Type A arrangement should not be less than two.

IS/IEC 62305 has specified the minimum length of earth electrodes but the criteria shall be neglected if the overall earth resistance value of the earth termination system measured is lesser than 10ohms.

In type A arrangement, the vertical electrodes are more preferred than the horizontal electrodes because of the following reasons.

- To achieve a seasonally-stable earthing resistance.
- Deeper the electrode lesser will be the earth electrode resistance.
- Deeper the electrode lower will be the potential at the surface of soil.

If the resistivity of soil is much higher then type B earthing arrangement is generally preferred.

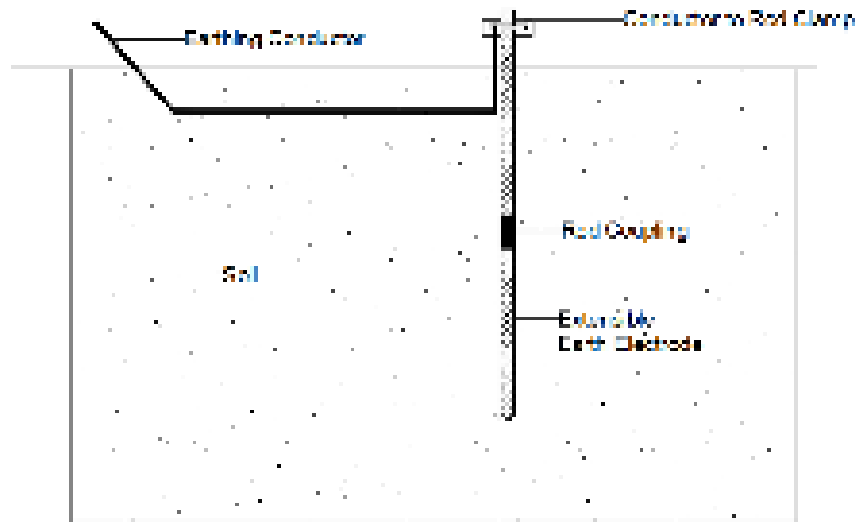

Figure 39. Type A earthing arrangement

Type – B arrangement:

In type B arrangement, the conductor is laid in the form of ring external to the structure to be protected forming a closed loop. In this ring earth assembly, at least 80% of total length of conductor should be in contact with the soil. The ring earth electrodes should be buried at a depth of at least 0.5m and it should be laid 1m away from the external walls.

Ring earthing is used in places where the soil resistivity much higher, or rocky regions.

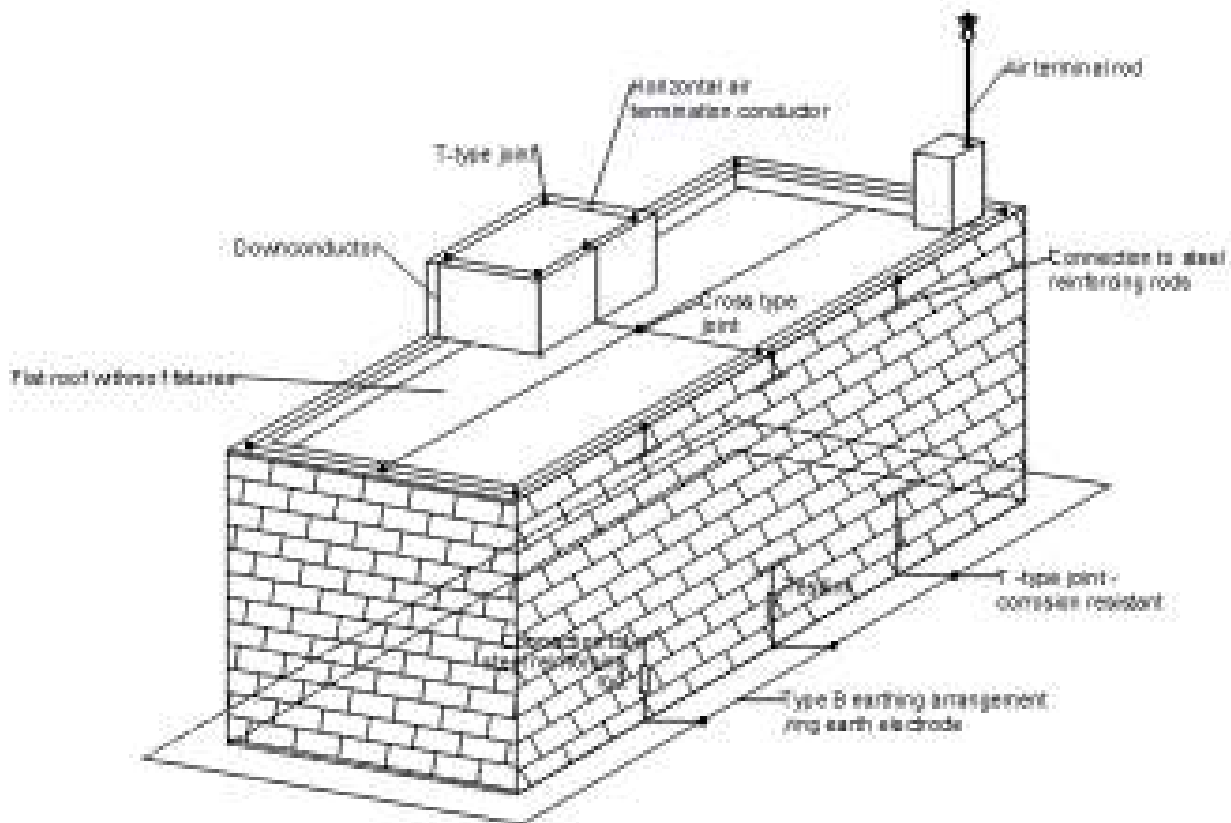

Figure 40. Type B earthing arrangement

IS/IEC62305 has provided the minimum dimensions required for different configurations of the materials to be used as earth electrode for lightning protection system.

Goose Foot Earthing Arrangement:

Goose foot earthing is an arrangement consisting of 3 long conductors each of above 7-8m in length buried horizontally deep at a depth of minimum 0.5m. These three conductors will be arranged in the form of a goose foot and hence this is named as goose foot arrangement. Except aluminium, the conductors used should be of same nature & cross-sectional area as the down conductor.

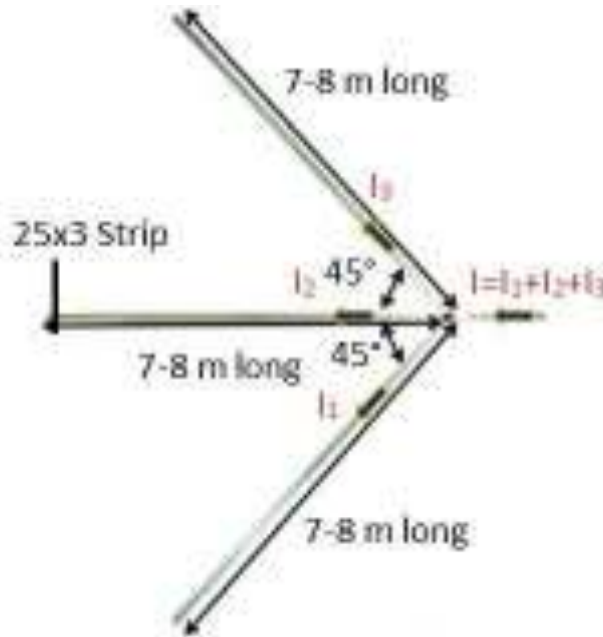

Figure 41. Goose foot earthing arrangement

This arrangement is commonly used for rocky regions and for regions where the soil resistivity is higher. This arrangement is specified by NFC 17-102:2011.

3.9 Foundation Earthing

Introduction:

Earth-termination systems should perform the following tasks:

- Dissipating the lightning impulse current and other fault currents into the earth;
- Equipotential bonding between the down-conductors;
- Maintaining the potential of conductive building walls within the same limit.

Foundation earthing meets all the above requirements. The reinforcing rods of the foundation, foundation slab and outer walls in the region below the soil surface are used as natural components of earth termination system. In larger structures and industries, the foundation of the building itself shall be used as earthing.

The advantages of the foundation earthing are as follows.

- The foundation earthing termination provides a very low earthing resistance for the dissipation of fault current.
- Equipotential bonding shall be achieved very easily with the foundation earthing.
- The concrete covering the foundation earth electrode protects the conductor against corrosion. But the material has to be selected as per the specifications provided by IE/IEC62305 part 3.

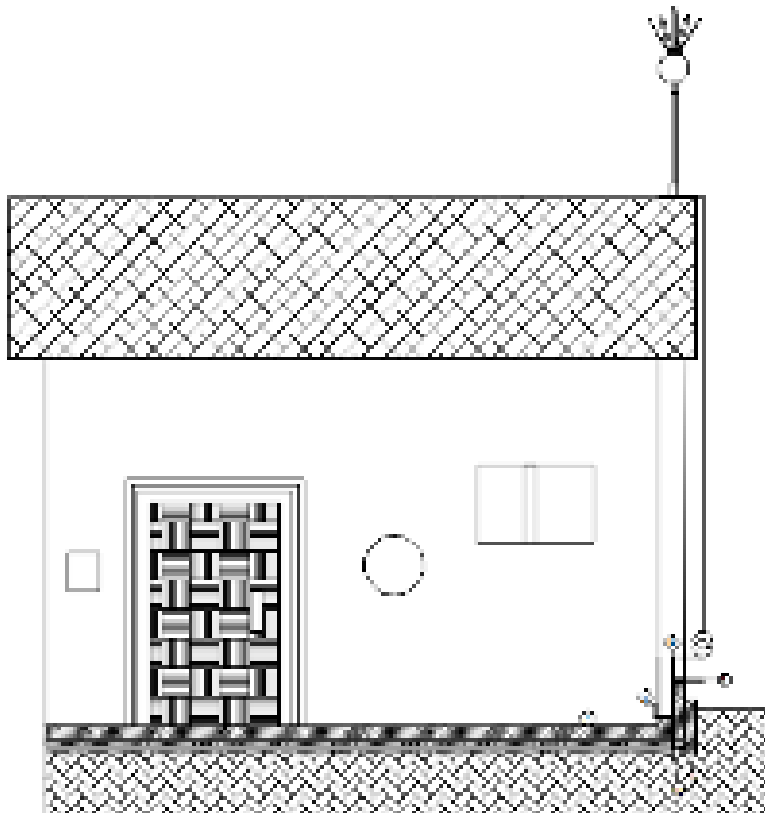

Figure 42. Foundation earthing

Materials in Foundation Earthing:

The reinforced rods of the foundation and buried walls can be used as foundation earth electrode. The reinforcing rods of each concrete columns should be connected to the reinforcing rods of the foundation and to the conductive parts of the roof. A foundation earth electrode in the form of mesh not exceeding 10m in size shall be installed in the foundation of the buildings.

Metals used for foundation earth electrode should conform to the requirements as per IS/IEC 62305 Part 3 as the improper materials combination may increase the corrosion rate due to galvanic corrosion.

For example, Steel in concrete has approximately the same galvanic potential in the electrochemical series as copper in soil. Hence earth electrodes in the soil should be made of either copper, copper coated steel or stainless steel conductors shall be connected to steel in concrete. If the conductor in concrete and soil both are steel then a galvanic potential difference of approximately 1V occurs which causes the corrosion current to flow through the soil.

IS/IEC62305 part 3 under clause E.5.4.3.2 explains about the various parameters to be considered while selecting the materials for foundation earthing.

3.10 Earthing Recommendations for Telecommunication System

Introduction:

Telecommunication is one of the main factors for industrial revolution and it has become a part and parcel of our life. Over a period of time, we have witnessed a tremendous growth in telecommunication system and currently we are upgrading to 5G technology. The advancement in data processing and data transfer leads to next transformation of industries which is Industry 4.0.

The electronic devices which we use for telecommunication are very sensitive to noise and fault currents of very low magnitude. High sensitivity of these devices makes grounding, bonding & lightning protection as a critical element in design of a telecommunications facility. Considering the importance of earthing in telecommunication system, IS 3043 recommends the following earthing practices for telecommunication equipment.

Earthing for Telecommunication circuits and equipment

Good grounding systems will protect the telecommunications network, against the devastating effects of lightning and reduce the noise level in everyday operations. There are two kinds of earthing involved in telecommunication system. They are,

- Protection Earthing
- Functional Earthing

Protection Earthing:

Earthing arrangements for protection purposes shall be provided to ensure the safety of equipment and the operating person during the fault conditions.

Functional Earthing:

Earthing arrangements for functional purposes shall be provided to ensure correct operation of equipment or to permit reliable and proper functioning of installations.

The telecommunication systems may require functional earths for the following purposes:

- To complete the circuits of telegraph on-earth path for signaling purposes;
- To maintain the potential of the equipment within the safe limit with respect to earth.
- For lightning protection devices
- To reduce electrical interference to the telecommunication circuits by earthing the screening conductors.

Recommendations:

- If an equipment requires both a protective earth and a functional earth connection, it is preferred that the two earths should be separated within the equipment. Hence any fault current on the power system conductors won't flow in the functional earthing conductors. In such cases the size of functional earthing conductors can be reduced to meet the requirements of the telecommunication system current alone.

- If the protective earthing and functional earthing are connected inside the equipment then the earthing conductor of functional earthing should also be capable of withstanding the fault current in protective earthing.
- The general recommendations for lightning protection system as provided by IS/IEC 62305 is applicable to telecommunication lightning protection system as well.

Telecommunication Circuits Association with High Voltage Supply Systems

In low voltage system, the fault current associated with the electrical system is very low and hence the electromagnetic fields generated by such fault current is also very low. But in High voltage supply systems, the magnitude of fault current will be very high and the electromagnetic fields generated during the passage of fault current can cause interference and undesirable noise in the telecommunication cables and circuits. The ground potential rise during the fault on high voltage system also affects the telecommunication circuits. Hence, special precautions have to be taken to prevent the rise of voltage on the earthing system of the high voltage equipment being transferred to the telecommunication circuits.



Figure 43. Telecommunication tower in building

When a telecommunication circuit installed in a building is electrically connected to a high voltage system in the building, then precautions should be taken to safeguard the operating person and telecommunication devices against the rise of potential of the earth electrode system. Any area within 5m of the earth-electrode system is generally considered as the earth-electrode area.

Recommendations:

IS3043 recommends the following practices for earthing of telecommunication circuits which are associated with high voltage systems.

- Within a station, all the accessible metal parts of the telecommunication installation should be connected to the station earth-electrode system to avoid the difference in potential. But the telecommunication cables should be laid away from the earthing conductors to reduce the interference on the signals due to fault currents.
- If the neutral of the high voltage system is earthed in the station, then the rise of earth potential during the maximum earth-fault current should be calculated. If the estimate is above safe limits, the following additional precautions should be observed.

Where, U is the estimated rise of earth potential between conductors and earth for 1 min.

- Where the telecommunication circuit lies within the 'earth-electrode area', the insulated cable should be capable of withstanding the test voltage of 2200 Vdc (or ac 50 Hz peak) or $(1\ 500 + 2U)$ V dc (or ac 50 Hz peak). All wiring and apparatus connected to the line side of this barrier should be insulated from the station earth to withstand the same test voltage.
- Any earth connection for the telecommunication circuit required on the line side of isolating barrier should be obtained from a point outside the earth electrode area via either a pair in the telecommunication cable or a cable insulated in accordance with (c).

The above recommendations are normally confined to stations where the neutral of a 33 kV or higher voltage system is earthed.