

Enclosures and assembly certification



10

POWER GUIDE 2009 / **BOOK 10**

INTRO

As with the choice of devices and busbars, the definition of enclosures and their configuration (dimensions, separation devices, combination, doors, faceplates, etc.) is essential in terms of the performance of the assembly that is created: heat dissipation, short-circuit resistance, etc. All these performance levels can be confirmed by a certification process.

XL³ are divided into four ranges according to the maximum current-carrying capacity: XL³ 160, XL³ 400, XL³ 800 and XL³ 4000.

Each one is available in a wide range of sizes and versions (insulated, metal, IP 30, IP 55).

They can take forms 2a to 4b level separation devices to meet requirements for continuity of service and safe maintenance.

The standard for certification of assemblies that has been applied for many years, and is still applicable, is IEC 60439-1. The procedure for certification of assemblies is described in this book in accordance with this standard.

A new standard, IEC 61439-1, issued by the IEC in 2009, is to replace it over the next few years. It will not make any fundamental changes to the philosophy of the approach to certification. It will allow verification of compliance with requirements to be carried out by other means, such as inspection, calculation, analogy or simulation.

As a corollary of the broadening of the methods of proving compliance, the new standard changes the field of responsibility, giving a leading role to the final assembler.

As a "Worldwide major player in power solutions", Legrand is anticipating this forthcoming change by giving the key points in a document included with this book.

XL³ enclosures	
XL ³ 160 enclosures	03
XL ³ 400 enclosures	05
XL ³ 800 enclosures	07
XL ³ 4000 enclosures	10
Physical accessibility and protection provisions	
Forms of internal separation	14
Certification of assemblies	
Standards	20
Type tests	21
Additional type tests	23
Routine verifications	25
Checking electromagnetic compatibility	32
Marks and information	33
Choice of products	
XL ³ 160 "ready to use" distribution cabinets	34
XL ³ 400 metal cabinets and enclosures	36
XL ³ 800 cabinets and enclosures	38
XL ³ 4000 enclosures	40
General accessories	42
Annexes	
Heat dissipation of XL ³ enclosures	44
Recommended tightening torque values	58
List of test reports	59
Model declaration and model report	60

XL³ enclosures

Legrand XL³ devices have been designed to meet the needs of all power distribution requirements up to 4000 A. From the XL³ 160 up to the XL³ 4000, all the enclosures provide optimum performance and are very easy to install.

XL³ enclosures are divided into four ranges according to the maximum current-carrying capacity: XL³ 160, XL³ 400, XL³ 800 and XL³ 4000. Each one is available in a wide range of sizes and versions (insulated, metal, IP 30, IP 55).



All models can take ¼ turn faceplates (locked by metal ¼ turn) with handles. They are sealable and have a large area for marking. On metal faceplates, the equipotential link is provided automatically and an additional earth terminal is provided in case of mounting devices on the faceplate.



^ ¼ turn faceplates with handles: easy fitting and removal

Segmentation of the XL³ range

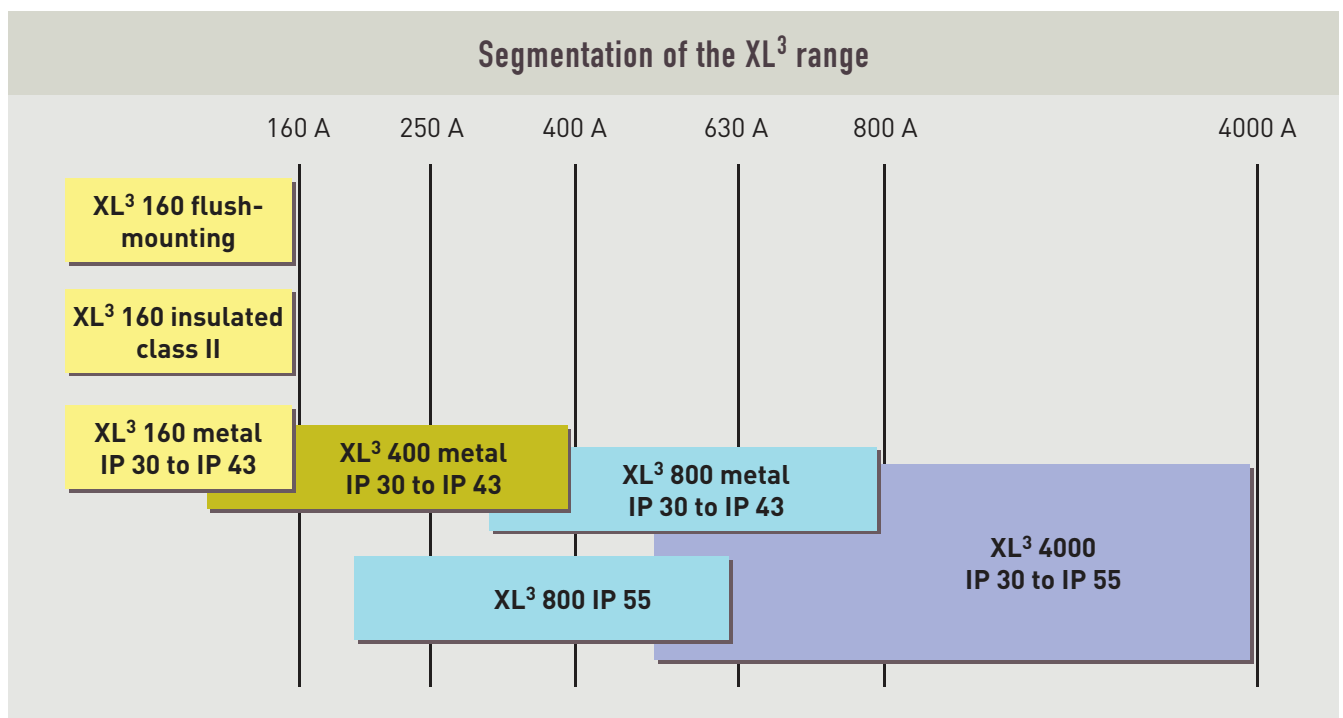

XL³ 160 ENCLOSURES

XL³ 160 enclosures are mainly designed to take modular devices. They are delivered ready to use with 24-module rails, faceplates and earth terminal block fitted. They are available in insulated, metal and flush-mounting versions, in several heights (from 2 to 6 rows). Dedicated models are available to take a DPX 125, 160 or Vistop 160 main device. Removing the side panels or extracting the chassis provides total access for installing devices and for wiring. The 200 mm top and bottom faceplates leave a wide space for connecting and spreading incoming and outgoing conductors. Clever solutions make it easy to route the wiring and hold it in place. The three available types of door provide an IP 40 (IP 43 with seal) protection index and ensure a perfect finish.



^ When the side panels have been removed, the wiring is fully accessible



^ The enclosures have wiring guide rings



Metal enclosure with 6 rows
Cat. No. 200 06



Insulated enclosure with 3 rows
Cat. No. 200 53



Flush-mounted enclosure with 3 rows
Cat. No. 202 13 with door Cat. No. 202 83

XL³ Enclosures (continued)

Choice of finishes



Flat solid door



Curved solid door



Flat glass door

Characteristics of XL³ 160 enclosures

Version	Insulated	Metal	Flush mounted
Insulation class	II	I	I
Short-circuit resistance Conditional short-circuit current I _{sc} ⁽¹⁾	25 kA	25 kA	25 kA
Fire resistance according to IEC 60695-2-1	750°C/5s	750°C/5s	750°C/5s
Protection against solid bodies and liquids	Without door	IP 30	IP 30
	With door	IP 40	IP 40
	With door and seal	IP 43	-
Protection against mechanical impact	Without door	IK 04	IK 04
	With door	IK 07	IK 08
Equipment width	24 modules	24 modules	24 modules
Total width	575 mm	575 mm	670 mm
Number of modular rows	2 to 6	2 to 6	3 to 6
Total height	450 to 1050 mm	450 to 1050 mm	695 to 1145 mm
Total depth	147 mm	147 mm	100 mm
Colour	RAL 7035		
Conformity to standards	IEC 60439-1 and IEC 60439-3		

(1) Subject to the components, devices and busbars being sized for this stress

XL³ 400 ENCLOSURES

1 IP 30-43 METAL ENCLOSURES

All XL³ 400 enclosures have a 24-module equipment width.

In addition to modular devices, XL³ 400 enclosures can take front terminal versions of DPX 125, 160, 250 ER, 250, 630 (400 A max.), as well as DPX-IS 250 and 630 (400 A) and Vistop up to 160 A. They are delivered dismantled for ease of fitting equipment and wiring.

The functional uprights integrated at the back of the enclosures enable quick and reliable fixing of all equipment. The standardisation of the elements makes them particularly easy to fit: a screwdriver and a 10 mm spanner are all that is required.

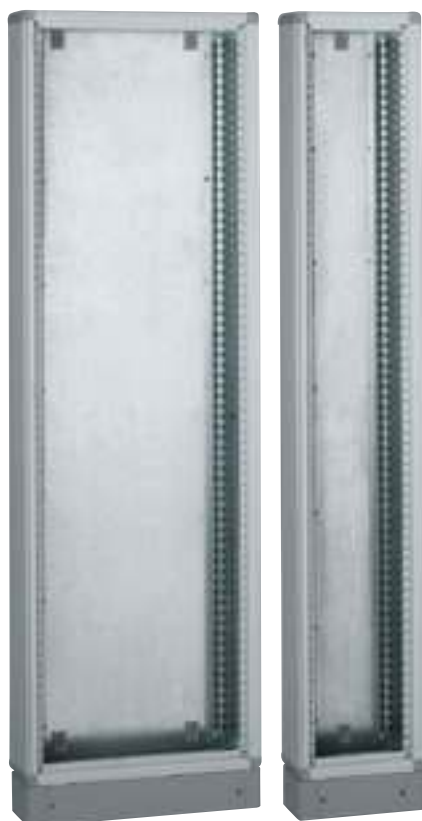

^ Metal enclosure and cable sleeve

Enclosures can be joined without any additional accessory.

The cable sleeves are extendable. They can be joined to the right or left of enclosures and can even be used on their own as small enclosures. The four available types of door provide an IP 40 (IP 43 with seal) protection index and ensure a perfect finish.

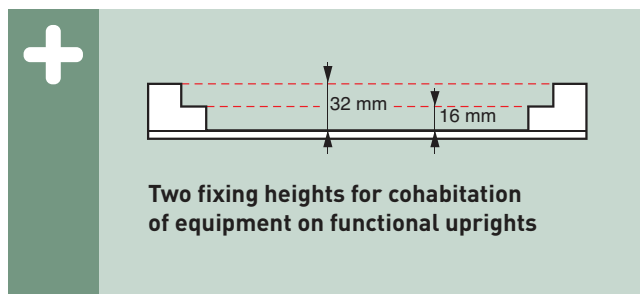

Freedom to combine enclosures with no additional accessory

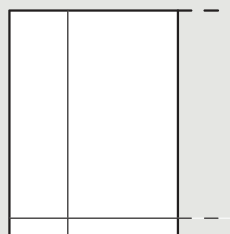

Cable sleeve on right or left

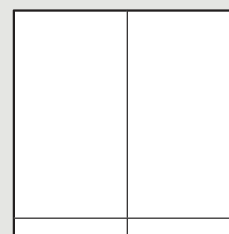

side by side horizontal...



vertical...

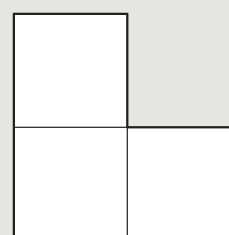

or both

XL³ Enclosures (continued)

2 DISTRIBUTION

XL³ 400 offers a choice of distribution system with distribution blocks and busbars in enclosures or cable sleeves.



^ Flat bars at the back of the enclosure



^ Flat bars in cable sleeve

Characteristics of XL³ 400 metal enclosures

Insulation class		I
Short-circuit resistance ⁽¹⁾	Conditional short-circuit current I _{sc}	36 kA
	Short-time withstand current I _{cw}	25 kA 1s
Fire resistance according to IEC 60695-2-1		750°C/5s
Protection against solid bodies and liquids	Without door	IP 30
	With door	IP 40
	With door and seal	IP 43
Protection against mechanical impact	Without door	IK 07
	With door	IK 08
Equipment width		24 modules
Total width		575 mm
Height with faceplate		550 to 1150 mm
Total height		600 to 1200 mm
Total depth		175 mm
Colour		RAL 7035
Conformity to standards		IEC 60439-1

(1) Subject to the components, devices and busbars being sized for this stress

XL³ 800 ENCLOSURES

XL³ 800 enclosures are available in 2 versions (metal and IP 55) and in 2 widths (24-module and 36-module). Their volume is in particular optimised, with a total depth of 230 mm (250 mm in IP 55 version with door). 36-module wide enclosures can take an internal cable sleeve, thus leaving a 24-module equipment width.

All versions can take a standard busbar at the back of the enclosure or in a cable sleeve.

1 METAL IP 30-43 ENCLOSURES

As with XL³ 400, these are delivered dismantled, ready to take equipment. As well as modular devices, they can take front terminal fixed version DPX-IS, Vistop and DPX up to 800 A.

2 IP 55 SEALED ENCLOSURES

These consist of a one-piece metal structure with open sides (side panels to be ordered separately). They can also be joined horizontally to constitute shallow, large sealed assemblies. They take front terminal fixed version DPX-IS, Vistop and DPX devices up to 630 A.



IP 30 metal enclosures, 24 and 36-module widths

IP 55 enclosure, supplied without side panels or doors

XL³ Enclosures (continued)

Choice of faceplates



Sealable 1/4 turn faceplate in 24-module width



Screw mounting faceplate in 24 and 36-module widths



Hinged faceplate in 24 and 36-module widths



^ All IP 55 enclosures can take an external cable sleeve and can be joined together



< External cable sleeves are extendable: DPX or DPX-IS 250 and 630

Choice of distribution

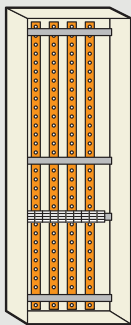

Busbar at back of enclosure

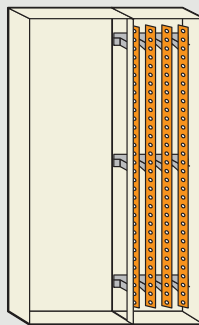

Busbar in external cable sleeve

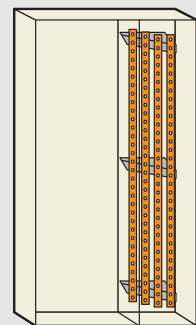

Busbar in internal cable sleeve



Combining devices on one plate

Devices of the same depth can be mounted on the same plate (fixing points marked). It is therefore possible to mount DPX 125, 160 and 250 ER or DPX 250 and 630 side by side.



Terminal blocks



Due to their reinforced aluminium profile, 2-position rails Cat.No. 206 00 and Cat.No. 206 50 can be used to create blocks that will withstand high mechanical stresses (heavy loads, large cross-section cables, etc). The distance between the rail and the faceplate is 70 mm in low position and 40 mm in high position

Characteristics of XL³ 800 enclosures

Version	Metal modular		IP 55	
Insulation class	I		I	
Short-circuit resistance I _{cw} ⁽¹⁾	25 kA 1s		25 kA 1s	
Fire resistance according to IEC 60695-2-1	750°C/5s		750°C/5s	
Protection against solid bodies and liquids	Without door	IP 30	-	
	With door	IP 40	-	
	With door and seal	IP 43	IP 55	
Protection against mechanical impact	Without door	IK 07	-	
	With door	IK 08	IK 08	
Equipment width	24 modules	36 modules	24 modules	36 modules
Total width	660 mm	910 mm	700 mm	950 mm
Height with faceplate	1000 to 1800 mm		1000 to 1800 mm	
Total height	1050 to 1950 mm		1095 to 1995 mm	
Total depth	230 mm (without door)		250 mm	
Colour	RAL 7035			
Conformity to standards	IEC 60439-1			

(1) Subject to the components, devices and busbars being sized for this stress

XL³ Enclosures (continued)

XL³ 4000 ENCLOSURES

XL³ 4000 enclosures can take all existing versions of Legrand breaking and protection devices, up to 4000 A, as well as numerous distribution solutions.

They are available in a single height, in 3 widths (24 modules, 36 modules, cable sleeve) and 3 depths.

The joining possibilities on all sides and the interchangeability of panels and doors enable an unlimited number of combinations to be created.

36-module wide enclosures can also take an internal cable sleeve while maintaining a 24-module equipment width.

The plates for fixed devices with front terminals are the same as in XL³ 800 and have the same cohabitation possibilities for devices of the same depth. For other mounting applications, the depth of the plates is adjustable thus enabling them to be adapted to plug-in and draw-out devices with or without motor-driven control.



^ Assembly consisting of a 24-module wide enclosure, an external cable sleeve and a 36-module wide enclosure with an internal cable sleeve



Freedom of joining

The modularity of their structure makes it possible to join enclosures side by side or back to back. Numerous configurations can therefore be created to meet the specific requirements of equipment rooms.

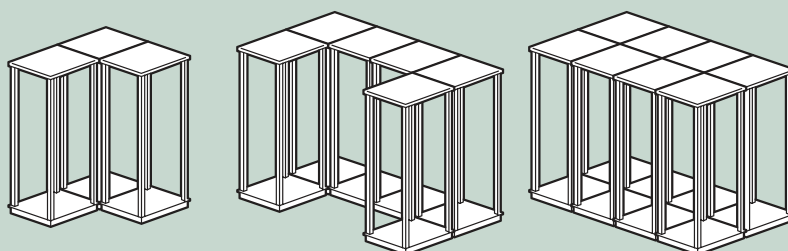

Choice of sizes

Depth (mm)	Width (mm)		
	475	725	975
475			
725			
975			



^ All XL³ 4000 enclosures and cable sleeves have sliding cable entry apertures at the bottom

Choice of distribution (copper or aluminium)

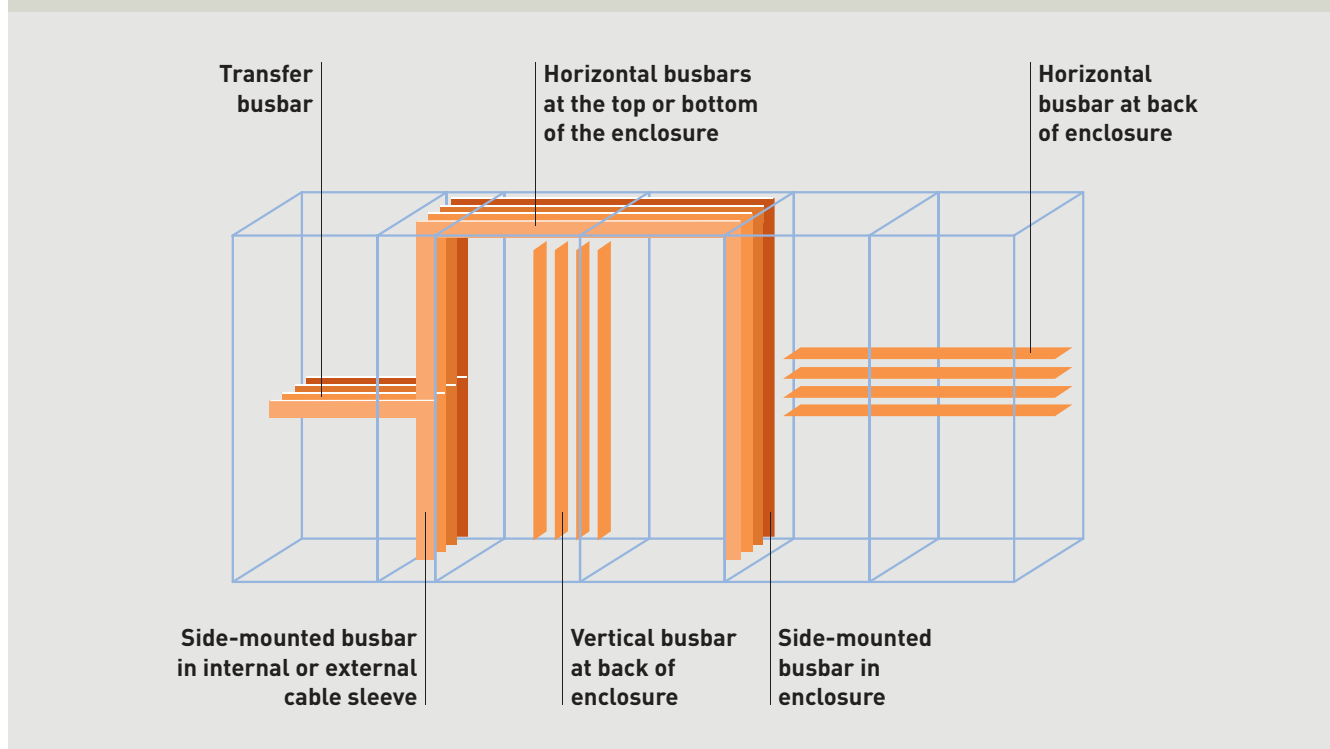

XL³ Enclosures (continued)

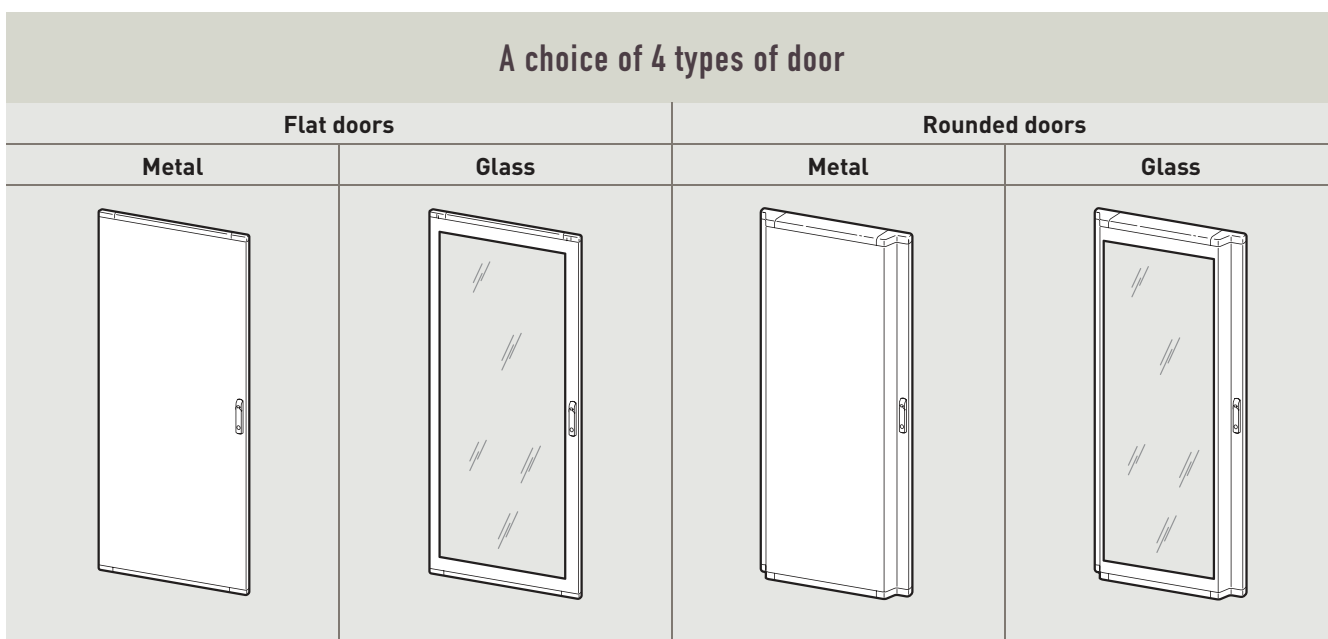

Characteristics of XL ³ 4000 enclosures			
Insulation class		I	
Short-circuit resistance I _{cw} ⁽¹⁾		110 kA 1s	
Fire resistance according to IEC 60695-2-1		750°C/5s and 960°C for active parts	
Protection against solid bodies and liquids	Without door	IP 30	
	With door	IP 55	
Protection against mechanical impact	Without door	IK 07	
	With door	IK 08	
Equipment width	24 modules	36 modules	cable sleeve
Total width	725 mm	975 mm	475 mm
Height with faceplate	1800 mm		
Total height	2000 mm		
Total depths	475, 725 and 975 mm		
Colour	RAL 7035		
Conformity to standards	IEC 60439-1		

⁽¹⁾ Subject to the components, devices and busbars being sized for this stress



XL Pro²: distribution panel design software



XL Pro² software provides unquestionable help and convenience for designing all distribution panels of all powers. Its database incorporates all Legrand products connected with distribution, together with their characteristics and prices. It automatically determines the enclosures required and the layout of the panel based on the devices and distribution systems to be installed and the wide range of customisable parameters. Its graphic interface and modular design make it particularly easy to use and enable it to be adapted to different ways of working.

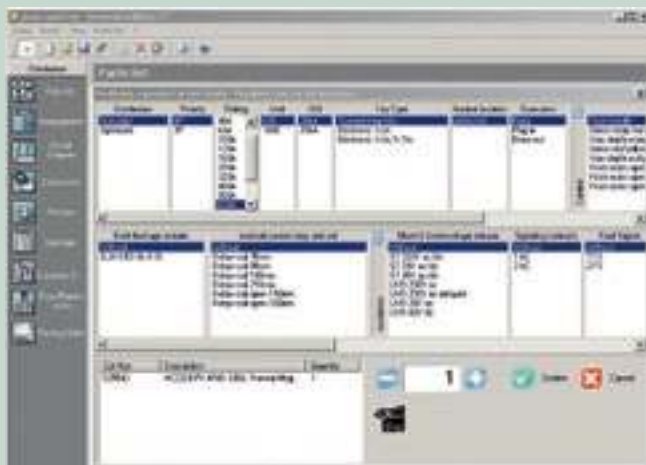

Selecting a device and its auxiliaries

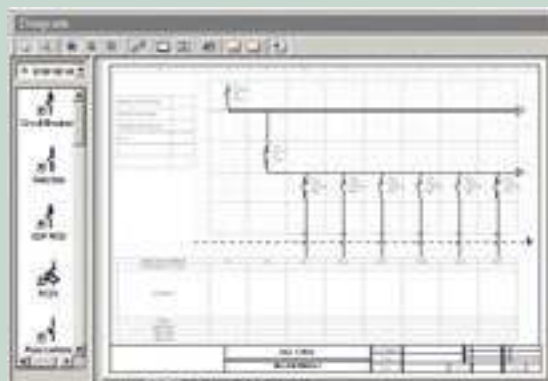

The parts list for the panel can also be created interactively while drawing the diagram

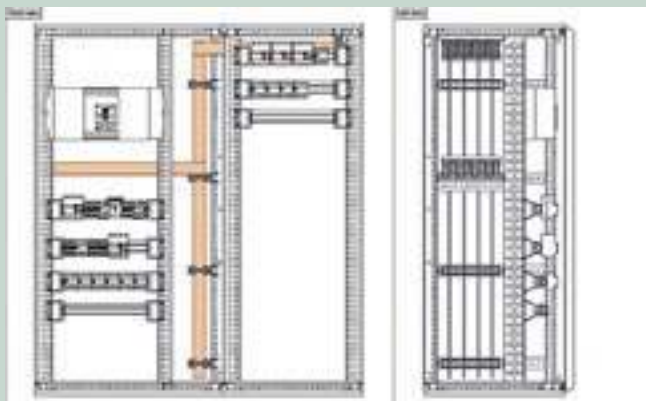

The proposed layout can be modified directly on the preview

Reference	Description	Quantity	Price Unit	Net Price	Gross Price
00000	Enclosure material and 4 cables	1	8,000.00	8,000.00	8,000.00
00001	Breaker 20kV - 100 A 10kV	1	22,500.00	22,500.00	22,500.00
00002	40kV 20kV 10kV 20kV	1	10,000.00	10,000.00	10,000.00
00003	20kV Break from 40 to 20kV	1	127,000.00	127,000.00	127,000.00
00004	20kV Break from 40 to 20kV	1	200,000.00	200,000.00	200,000.00
00005	Mounting plate of switches	1	5,000.00	5,000.00	5,000.00
00006	Set of 4 x 4000 vertical angle	1	200,000.00	200,000.00	200,000.00
00007	Set of 4 x 4000 vertical angle	1	200,000.00	200,000.00	200,000.00
00008	Set of 4 x 4000 vertical angle	1	200,000.00	200,000.00	200,000.00
00009	Set of 4 x 4000 vertical angle	1	200,000.00	200,000.00	200,000.00
00010	Set of 4 x 4000 vertical angle	1	200,000.00	200,000.00	200,000.00
00011	Set of 4 x 4000 vertical angle	1	200,000.00	200,000.00	200,000.00
00012	Set of 4 x 4000 vertical angle	1	200,000.00	200,000.00	200,000.00
00013	Set of 4 x 4000 vertical angle	1	200,000.00	200,000.00	200,000.00
00014	Set of 4 x 4000 vertical angle	1	200,000.00	200,000.00	200,000.00
00015	Set of 4 x 4000 vertical angle	1	200,000.00	200,000.00	200,000.00
00016	Set of 4 x 4000 vertical angle	1	200,000.00	200,000.00	200,000.00
00017	Set of 4 x 4000 vertical angle	1	200,000.00	200,000.00	200,000.00
00018	Set of 4 x 4000 vertical angle	1	200,000.00	200,000.00	200,000.00
00019	Set of 4 x 4000 vertical angle	1	200,000.00	200,000.00	200,000.00
00020	Set of 4 x 4000 vertical angle	1	200,000.00	200,000.00	200,000.00

XL Pro² draws up the purchase order and full costings

Physical accessibility and protection provisions

The main objective is to maintain the availability of the power supply while allowing safe working (protection index xxB) and limiting the effects of any internal fault in the panel (arcs, electrodynamic forces, disconnection, etc.)

FORMS OF INTERNAL SEPARATION

Forms are used to provide a gradual, appropriate response to the accessibility and protection of the main components of a power distribution panel: busbars and breaking and protection devices (functional units).

The type of form chosen will be determined according to the qualification of those involved, the protection required and the required level of maintainability. The use of forms enables the panel to be divided into closed protected spaces in order to achieve four objectives:

- Protection against direct contact with dangerous parts of neighbouring functional units (the degree of protection must be at least IP xxB)
- Protection against the entry of solid objects.

The degree of protection must be at least IP2x (degree IP 2x covers IP xxB). These two requirements assume that the assembly is equipped with faceplates.

- Limitation of the effects of the spread of electric arcs
- Facilitation of panel maintenance operations.

Standard EN 60439-1 defines the internal separation of assemblies into 7 types of form (1, 2a, 2b, 3a, 3b, 4a and 4b).

This internal separation is achieved in XL³ 4000 enclosures using barriers or screens made of metal or insulating material.

XL³ 4000 enclosures and their accessories can be used to create all types of form.



Partitioning used to create forms limits the natural ventilation of the panel and can therefore result in rises in temperature. It will inevitably increase the size and cost of the panel, both in terms of labour and components.



< Form 4b in the process of being set up in an XL³ enclosure

Form levels

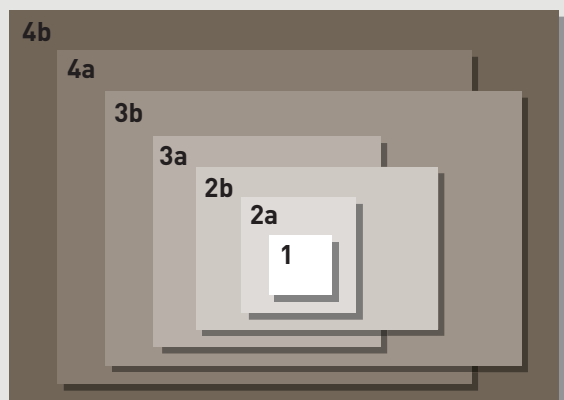

Object of this diagram is to give an overview of the principle of gradation of the different forms. Each form does not cover exactly the inferior. For further understanding, report to the detail drawing in following pages.

1 FORM 1

Form 1 does not require any separation between the components inside the enclosure.

2 FORMS 2a AND 2b

Form 2a is the simplest for protecting against accidental contact with the busbars, which are considered to be the most dangerous components. Form 2b includes additional separation to make it safe to work on outgoing lines.

Requirements of standards and creation in XL³ enclosures

■ Form 2a

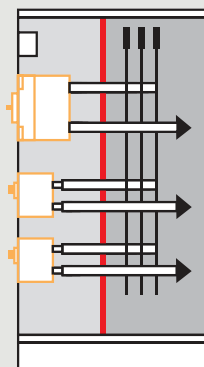

Separation of busbars from functional units.

Terminals for external conductors do not need to be separated from busbars.

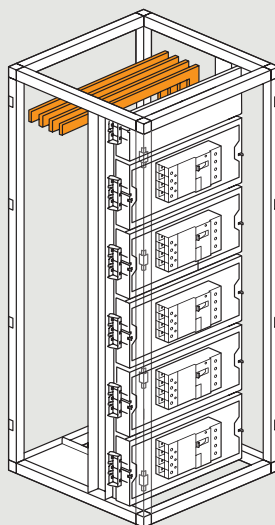

In XL³, the separation with the busbars is provided directly by the fixing plates. The devices are connected on rear terminals

■ Form 2b

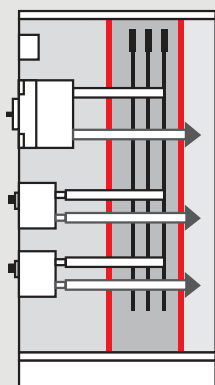

Separation of busbars from functional units.

Terminals for external conductors are separated from busbars.

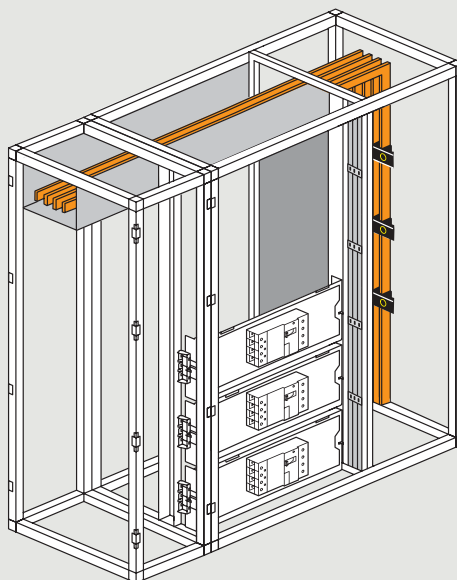

The devices are connected on the side-mounted busbar, on front terminals, through a vertical separation between the enclosure and the cable sleeve

Physical accessibility and protection provisions (continued)

3 FORMS 3a AND 3b

In form 3a, each device is isolated in a compartment which protects it from the effects of incidents which may occur on another device. Form 3b combines the advantages of form 3a and form 2b, separating the output terminals and the busbars. Form 3a does not cover completely the form 2b. The difference relates to the terminals for external conductors separated from busbar in form 2b and necessary in form 3a (see following diagrams for further understanding).

Requirements of standards and creation in XL³ enclosures

Form 3a

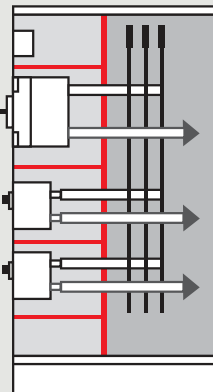

Separation of busbars from functional units and separation of all functional units from each other.

Terminals for external conductors are not separated from busbars.

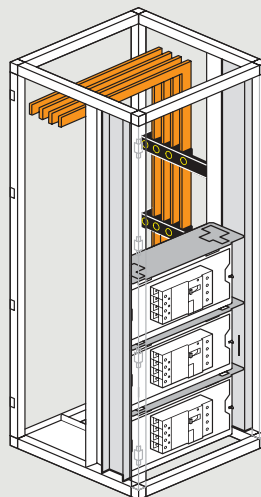

Form 3a is constructed based on form 2a with the addition of horizontal separations between the devices and vertical separations between the enclosures

Form 3b

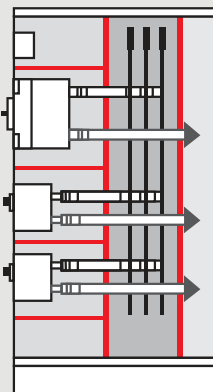

Separation of busbars from functional units and separation of all functional units from each other.

Terminals for external conductors are separated from busbars.

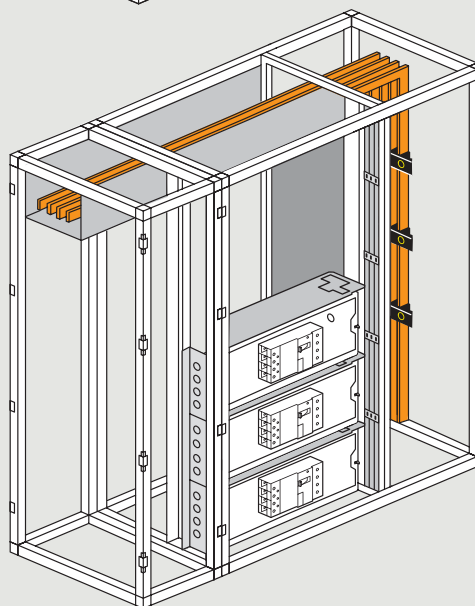

Form 3b is constructed based on form 2b with the addition of horizontal separations between the devices

4 FORMS 4a AND 4b

The requirements of form level 4a further increase the safety of working on outgoing lines by isolating the output terminals in the same compartment as the device. Form 4b provides maximum safety by separating all the functions from one another. Form 4a does not cover completely the form 3b since solutions for connecting external conductors are different. They are associated with the functional unit in the form 4a while being deported in the form 3b (see following diagrams for further understanding).

Requirements of standards and creation in XL³ enclosures

■ Form 4a

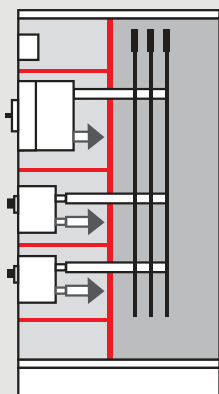

Separation of busbars from functional units and separation of all functional units from each other including the terminals for external conductors which are an integral part of the functional unit. Terminals for external conductors are in the same compartment as the functional unit.

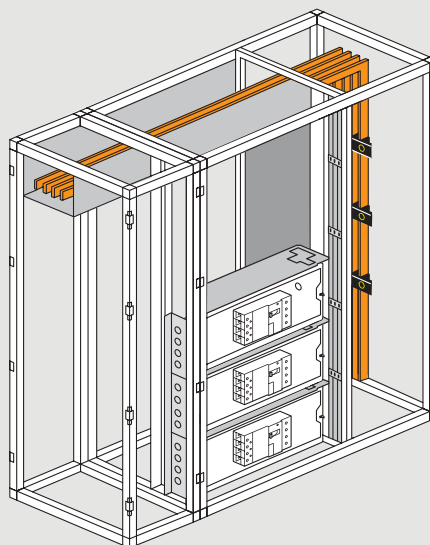

In XL³, form 4a is identical to form 3b but connexion of external conductors must be in the same compartment as the functional unit

■ Form 4b

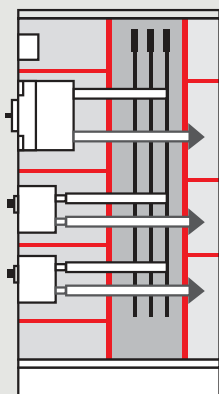

Separation of busbars from functional units and separation of all the functional units from each other including terminals for external conductors. Terminals for external conductors are not in the same compartment as the functional unit but in separate individual compartments.

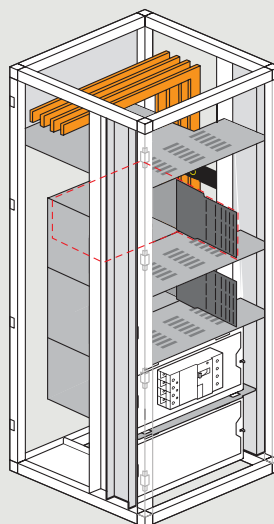

Each device is enclosed in a compartment. These compartments are stacked on top of each other and thus create the partitioning for the branch busbar

Physical accessibility and protection provisions (continued)

5 DETERMINING FORMS WITH XL PRO² SOFTWARE

5.1. Input data

To produce a design that includes forms, two mandatory pieces of information must be entered:

- The choice of product (DPX – DMX³ – DX)
- The associated busbar.

A busbar can be associated with the main device either in the “Nomenclature” module (Cabling products > Associated busbars and distribution blocks) or in the “Arrangement” module (right-click on the circuit breaker, select “To associate to this product” and then “Associated busbars”).



The busbar must be “top horizontal” or “side vertical” as these are the only distribution arrangements that can be partitioned in forms. If the assembly consists of more than two enclosures, the vertical busbars will be automatically connected using a top horizontal busbar. The horizontal busbar can be removed later if necessary.

XL-Pro² automatically creates branch busbars and the cable sleeves used to mount them.

5.2. Arrangement

Irrespective of the level of form required, the reference position for DPX is horizontal mounting.

In the “Arrangement” window, select all the devices then right-click to select “Mounting” then “Horizontal” (or click directly on the icon). All the devices selected will be transformed into horizontal mounting position (if this was not already the case).

If the DPX are not positioned horizontally, XL-Pro² will do this automatically when the type of form is chosen, except in the case of supply inverters.



For horizontally mounted supply inverters, select the inverter in the “Arrangement” window and right-click to select “Inverter mounting” and then “Horizontal”.

Depending on the installation of the panel, select whether devices will be connected via front terminals or rear terminals.

In the “Arrangement” window, select all the devices then right-click to select “Connection” then “Front Terminals” or “Rear Terminals” (or click directly on the icon).

All the devices selected will be transformed into front terminal or rear terminal connection depending on the choice made.

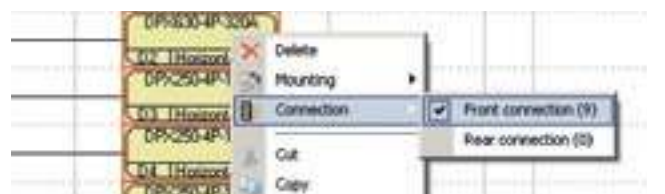

5.3. Selecting the enclosures

Products are selected in the same way as for a standard design.

In the “Enclosures” window click on the “Form...” button. If the panel does not have any associated busbar, XL-Pro² suggests adding one.

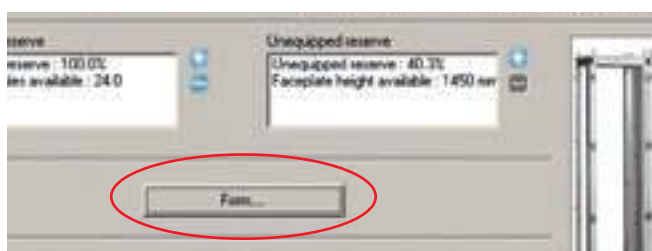

A window divided into 3 sections opens, for selecting:

1. The level of form required
2. The type of connection (front terminal or rear terminal)
3. The circuit diagram (power supply from the right, left or a “head-to-tail” power supply).

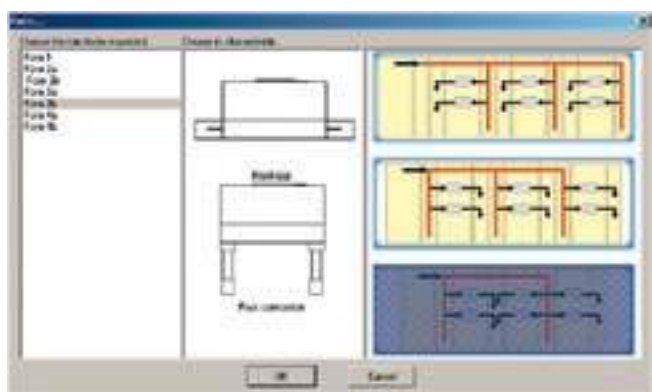

The “head-to-tail” circuit diagram is used to limit the number of branch busbars (and therefore the amount of copper used) but it requires alternate mounting of circuit breakers in the same enclosure assembly. In this case, the direction of opening must be clearly marked in order to ensure there is no ambiguity.

5.4. Preview

Once this information has been entered, XL-Pro² recalculates which enclosures are compatible. If the message “No family accepts the products selected” appears, this means that a product is incompatible with the enclosure configurations used to create the level of form required.

Example: technical impossibility of mounting a DPX-IS horizontally as mounting plates are only available for mounting in a vertical position. For these specific cases concerning DPX-IS, it is advisable to use special plates and faceplates for vertical mounting, with connection on the front terminals, and to partition the space between the mounting plates using adjustable solid plates.

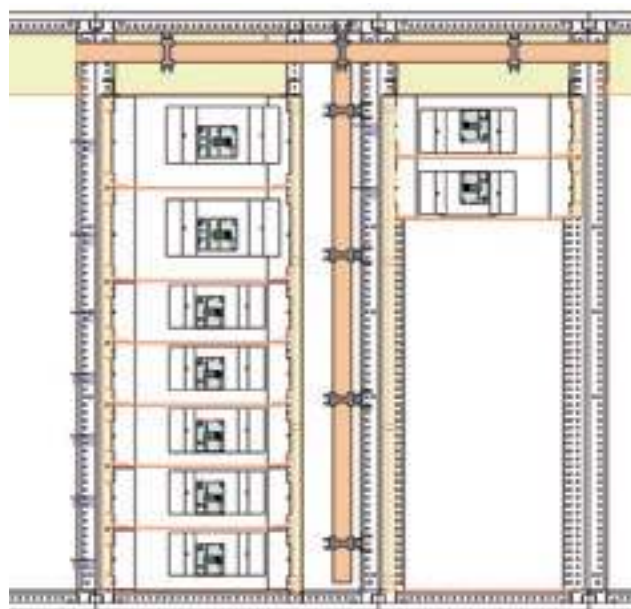

Certification of assemblies

Certification of assemblies is a simple process if it can be based on a product offer that has been tested and approved, and therefore all that remains for the assembly builder to do is carry out the check tests and the final inspection.

STANDARDS

Certification of distribution assemblies is defined by international standard IEC 60439-1.

This standard provides common rules that are recognised worldwide.

The standard formulates definitions, operating conditions, structural provisions, technical characteristics and tests for assemblies of low voltage wiring accessories, commonly known as the Main Distribution Board (MDB) and Subsidiary Distribution Board (SDB). Compliance of distribution assemblies with standard IEC 60439 is based on the principle of the declaration of the manufacturer or the final assembler. This voluntary process must not obscure the fact that it is based on three obligations:

- Construction of assemblies in representative configurations using products that have themselves been tested and comply with their own specific standards; these are the type tests carried out by Legrand
- Compliance with the selection and installation rules for these products in accordance with the methods defined by the standards and regulations, good professional practice and other precautions specified by the manufacturer of the products



How can compliance with the standard be certified?

Compliance with the standard is certified, depending on the country or market, by a declaration of the panel builder, the design office, the installer or the user. To avoid checks and tests that take a long time, are sometimes destructive, and above all too costly, the standard permits them to be reduced to the minimum, using "type tests" carried out and guaranteed by the manufacturer. This is what Legrand has done for its XL³ range.

- The carrying out of individual tests (insulation, continuity of the exposed conductive parts) and a final inspection, all recorded in a simplified individual report.

Total compliance with this process can then be certified by a declaration of conformity and the assembly can be marked accordingly. Compliance with standard IEC 60439 also enables the CE mark to be affixed, if required.

1 STANDARD ASSEMBLIES (SA)

A standard assembly is one which complies with an established model whose performance has been tested using type tests. As a general rule, the standard assembly is the most restricting configuration (Isc, density of devices) so that standard assemblies based on the same construction principles can refer to this tested assembly.

2 ASSEMBLIES DERIVED FROM THE STANDARD (ADS)

An assembly derived from the standard is one which contains both layouts that have undergone type tests (wiring, wiring accessories, distribution method) and original layouts. In these assemblies, only these original layouts have to be checked and certified by means of tests or calculations, by analogy or by extrapolation. This is the responsibility of the builder of the assembly. The tests carried out by Legrand on numerous configurations limit these investigations.

Information on technical definition data provided by Legrand can be used to check that the choices made for sizing enclosures, calculating busbars and protection treatment do in fact comply with the recommendations.

TYPE TESTS

Seven type tests are carried out officially on assemblies representative of the usual wiring configurations and equipment layouts.

These assemblies are called "Standard assemblies". By definition, standard assemblies only contain layouts that have undergone type tests. They cover the following checks:

- Temperature rise limits
- Dielectric properties
- Short-circuit resistance
- Effectiveness of the protective circuit
- Clearances and creepage distances
- Mechanical operation
- Degree of protection (IP).

1 TEMPERATURE RISE LIMITS

1.1. Temperature rise test on assemblies

This test checks that assemblies operate correctly under maximum operating conditions (current, number of devices, volume of enclosure). It is used to define the heat balance data for an average temperature rise of the air in assemblies of less than 30 K⁽¹⁾ and a temperature rise of the terminals of less than 70 K⁽¹⁾.

1.2. Temperature rise test on busbars

The various currents given for all the bar and distribution systems have been checked under the most severe conditions, according to the degree of ventilation of the enclosure (IP ≤ 30 and IP > 30), so that the temperature rise of the bars does not exceed 65 K.

2 DIELECTRIC PROPERTIES

The dielectric tests check the insulation performance levels for the maximum operating voltage. They are carried out at the industrial frequency of 50 Hz and in the form of voltage waves simulating a lightning strike.

3 SHORT-CIRCUIT RESISTANCE

The tests carried out ensure the resistance of busbars and their supports, breaking and protection devices and enclosures to thermal and electrodynamic stresses.

4 EFFECTIVENESS OF THE PROTECTIVE CIRCUIT

The continuity of the protective circuit is a decisive factor for safety. It is checked:

- In accordance with standard IEC 60439-1 at a test current of 25 A between the terminal connecting the protective conductors and all the exposed conductive parts
- At a high fault current that could occur following accidental detachment of a conductor.

The protective circuits (conductors, terminals or collector bars), are sized and tested to withstand the maximum short-circuit thermal stress that could occur according to the current at the supply end of the assembly.

5 CLEARANCES AND CREEPAGE DISTANCES

The methods for measuring creepage distances and clearances in standard IEC 60664-1 are repeated in full in appendix F of standard IEC 60439-1. The distances are measured between live parts with different polarities, and also between live parts and the exposed conductive parts.

When modular devices and equipment are installed in accordance with the specified conditions, the distances are observed for the insulation voltages of these devices. Experience has shown that the greatest risk is in the wiring. Connections, bundles of conductors and busbars must be meticulously checked. Unsuitable connectors, bolted connections, joints and metal supports can reduce the initially planned insulation values.

[1] The temperatures rises are given in Kelvin to differentiate them from temperatures given in °C

Certification of assemblies (continued)







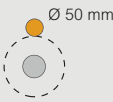
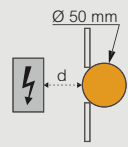

6 CHECKING MECHANICAL OPERATION

In accordance with the provisions of the standard, tests are carried out on parts and devices that are not subject to any specific requirements. Correct mechanical operation is checked by 50 operating cycles on draw-out racks and faceplate fixings.

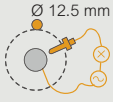
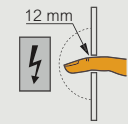
7 CHECKING THE DEGREE OF PROTECTION (IP)

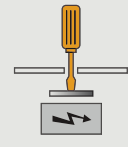
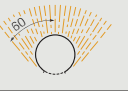
The IP defines the ability to protect people and to prevent entry of solid objects (first number) and against liquids (second number). The additional letter indicates the protection against access to dangerous parts. Legrand provides a perfect response to suit all environments with the XL³ and Altis ranges.

IP degrees of protection in accordance with standard IEC 60529

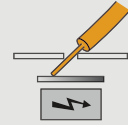
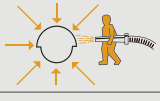
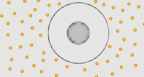
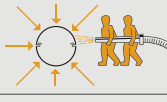
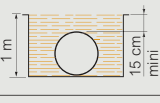
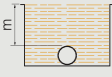
1 st digit: protection against solid bodies			Additional letter IP XX (ABCD): protection against direct contact resulting from the access to hazardous current-carrying parts			2 nd digit: protection against liquids		
IP	tests		IP	tests	Protection	IP	tests	
0		No protection				0		No protection
1		Protected against solid bodies larger than 50 mm	A		The back of the hand remains remote from dangerous parts	1		Protected against vertically-falling drops of water (condensation)
2		Protected against solid bodies larger than 12.5 mm	B		The dangerous parts can not be touched when introducing a finger	2		Protected against drops of water falling at up to 15° from the vertical
3		Protected against solid bodies larger than 2.5 mm	C		The dangerous parts can not be touched when introducing a tool (eg a screwdriver)	3		Protected against drops of rain water at up to 60° from the vertical
4		Protected against solid bodies larger than 1 mm				4		Protected against projections of water from all directions
5		Protected against dust (no harmful deposit)	D		The dangerous parts can not be touched when introducing a wire	5		Protected against jets of water from all directions
6		Completely protected against dust				6		Protected against jets of water of similar force to heavy seas
						7		Protected against the effects of immersion
						8		Protected against prolonged effects of immersion under pressure

ADDITIONAL TYPE TESTS

Defined by standard IEC 60439-3, six tests designed to check the construction quality are added to the seven type tests in standard IEC 60439-1.

They are applied to distribution panels whose incoming current is not more than 250 A at the supply end and which are to be installed in locations that are accessible to unqualified people (residential and commercial applications, public buildings, etc.).

They cover the following checks:

- Resistance to mechanical impact
- Rust resistance
- Resistance to damp
- Resistance of insulating materials to heat
- Fire resistance
- Mechanical performance of assemblies and fixings.

1 RESISTANCE TO MECHANICAL IMPACT



< Pendulum impact test on an Altis enclosure

1.1. Spring hammer test

This test is carried out in accordance with IEC 60068-2-63 at a temperature of - 5°C with a spring hammer delivering an energy of 0.7 joule.

1.2. Pendulum impact test

Carried out in accordance with European standard EN 50102, this test determines the degree of impact protection (IK).

IK degrees of protection against mechanical impacts according to standard EN 50102

IK	Tests	Impact energy (in Joules)
IK 00		0
IK 01		0.15
IK 02		0.2
IK 03		0.35
IK 04		0.5
IK 05		0.7
IK 06		1
IK 07		2
IK 08		5
IK 09		10
IK 10		20

Certification of assemblies (continued)

2 RUST RESISTANCE

2.1. Ammonium chloride test

This test checks that there is no rust present after 10 minutes' immersion in a solution of ammonium chloride (according to IEC 60439-3).

2.2. Salt spray test

This test, carried out in accordance with IEC 60068-2-11, ensures more than 168 hours' resistance to salt spray on XL³ enclosures and more than 500 hours on Altis enclosures.

3 RESISTANCE TO DAMP

This test, carried out in accordance with standard IEC 60068-2-3, checks that the insulation characteristics of the enclosure, busbars and conductor supports are not affected after 4 hours' exposure in a steam chest (40°C at 95% relative humidity).

The insulation used has a tracking current resistance of at least 400 V, which means it is not very sensitive to damp (group I and group II according to IEC 60664-1).

4 RESISTANCE OF INSULATING MATERIALS TO HEAT

4.1. Test involving 168 hours' exposure at 70°C

After 168 hours' exposure at 70°C, in accordance with standard IEC 60439-3, the assemblies tested do not show any damage likely to affect their use.

4.2. Ball impact test

This is carried out on the materials themselves to check that there is no warm creep. After exposure to the test temperature of 125°C for parts that hold live parts in place and 70°C for the others, the measured impression of the ball must not exceed 2 mm.

5 FIRE RESISTANCE

The glow wire test in standard IEC 60695-2-1 checks the fire behaviour of the materials and their ability to extinguish themselves (self-extinguishing ability). The test temperature is 960°C for the parts that hold live parts in place, and 650°C for other parts. Extinguishing must take place in less than 30 seconds. All elements that make up XL³ and Altis assemblies comply with this requirement.



< Glow wire test

6 MECHANICAL PERFORMANCE OF ASSEMBLIES AND FIXINGS

The test consists of tightening screws and nuts up to the torque required by standard IEC 60439-3 and then loosening them: five times for metal screws and nuts and ten times for those made of insulating materials.



< Ball impact test

ROUTINE VERIFICATIONS

Individual tests or routine verifications are intended to check the essential safety aspects of assemblies that could be affected by hazards during mounting or possible manufacturing faults. In principle, they must be carried out on all assemblies, either in the workshop or at the installation site. If the assemblies are transported as dismantled units, it is preferable to carry out these tests after reassembly on site.

The individual tests comprise:

- Checking the insulation
- Checking the continuity of the protective circuits
- Inspection and final check.

They must form the subject of an individual inspection report.

1 CHECKING THE INSULATION

This check can be carried out using a dielectric test or by measuring the insulation resistance.



The measurement of the insulation resistance must be considered as being in addition to checking the distances during the visual inspection of the assembly. Inadequate distances cannot only be detected by the impulse voltage dielectric test.

- Devices (measurement windings, instruments) which would not withstand the test voltage must have their supply terminals short-circuited.

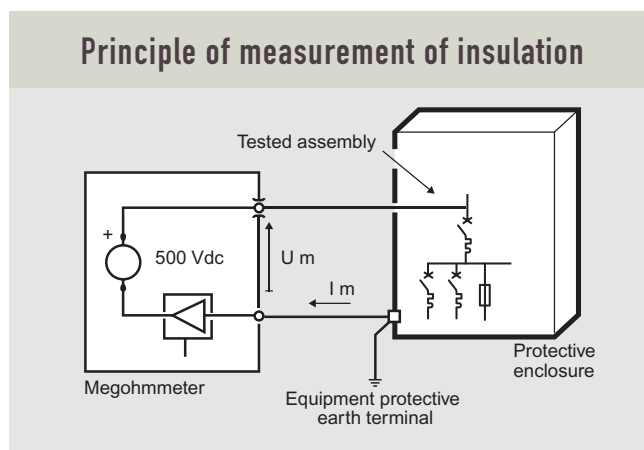

The minimum value measured must be, according to standard IEC 60439-1, $1000 \Omega/V$ with reference to the nominal voltage in relation to the earth of the circuit being tested. In practice, a target value of at least $0.5 M\Omega$ should be used for 230/400 V assemblies and at least $1 M\Omega$ above that.

1.1. Measurement of the insulation resistance

- The insulation resistance must be measured with a megohmmeter (external or with standalone source) at a minimum voltage of 500 VDC
- The assembly being tested must be turned off and there must be no receiver devices connected
- All the breaking devices must be in position I (ON)
- The voltage is applied between each circuit and the exposed conductive part
- It is possible to link all the poles: phases and neutral, except in TNC layout in which the PEN conductor is considered to be linked to the exposed conductive part of the assembly

The measurement conditions can influence the results obtained. Measurements should not be carried out at temperatures below dewpoint (condensation will dampen the surfaces).

The insulation resistance decreases with the temperature. If repeated measurements have to be taken, the environmental conditions must be recorded.

The period for which the voltage is applied also has a major influence, and measurement can be considered to consist of three sequences. At the start of measurement, the device charges the capacitor which represents the installation in relation to earth and the leakage current is at its highest.

Certification of assemblies (continued)

At the end of this charge, the current stabilises and is only due to the insulation resistance. If the voltage continues to be applied, it will be noted that the resistance continues to increase slowly. This phenomenon is due to the decrease of the dielectric absorption current. A measurement would require calculation of the ratio of the resistances (R) measured at 1 min and 10 min.

A value $R_{10\text{ min}}/R_{1\text{ min}} > 2$ indicates good insulation. In practice, the minimum value threshold is increased and the measurement time is decreased, but must not be less than 1 min.

1.2. Dielectric test

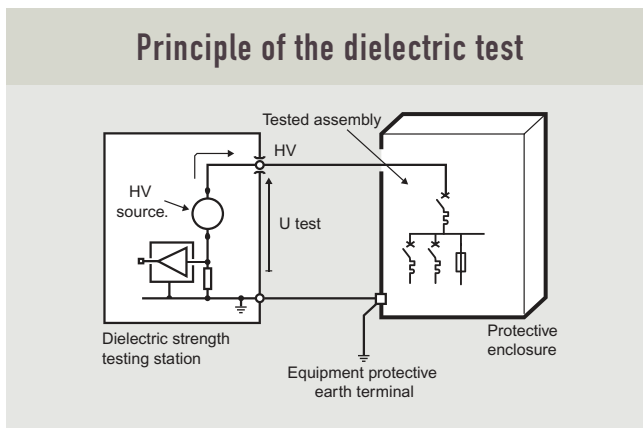

If the insulation resistance has not been measured, the dielectric test must be carried out according to the instructions or specifications connected with the assembly.

- Test at industrial frequency for a given insulation value U_i

- Impulse voltage test (1.2/50 μ s wave) for a given U_{imp} value conditions applicable to both types of test
- The assembly being tested must be turned off and there must be no receiver devices connected.

The test voltage must be applied according to the following sequence:

- Between each pole of each circuit (power, control, auxiliaries) and the exposed conductive part of the assembly
- Between each pole of the main circuit and the other poles (between each phase and between each phase and neutral)

- Between each circuit if they are not electrically connected (for example, separate control circuit or SELV and main circuit)
- Between protective circuit and exposed conductive part for class II assemblies
- Between drawn-out or separate parts for the isolation breaking function
- Devices that could be damaged by the application of voltage (measurement or detection devices, electronic releases) must have one of their terminals disconnected and isolated
- Interference suppression capacitors must not be disconnected.

Test at industrial frequency

The voltage is applied for at least 1 second. There must be no breakdown or flashover.

Insulation voltage U_i (V)	Test voltage (V)
$U_i \leq 60$	1000
$60 < U_i \leq 300$	2000
$300 < U_i \leq 690$	2500
$690 < U_i \leq 800$	3000
$800 < U_i \leq 1000$	3500

Voltage impulse test

The voltage is applied three times for each polarity at intervals of at least 1 s. The value applied corresponds to the U_{imp} value increased by the correction associated to the altitude of the location.

Given impulse voltage U_{imp} (kV)	Test voltage (kV)				
	Sea level	200 m	500 m	1000 m	2000 m
2.5	2.9	2.8	2.8	2.7	2.5
4	4.5	4.8	4.7	4.4	4
6	7.4	7.2	7	6.7	6
8	9.8	9.6	9.3	9	8
12	14.8	14.8	14	13.3	12



The high voltage testing technique requires basic safety precautions (marking out of the test area, wearing of insulated gloves, qualified staff), as well as the precautions associated with the test itself:

- Avoid switching overvoltages by starting the test at 0 V and returning to 0 V before switching off the high voltage
- The period of the individual acceptance test in standard IEC 60439-1 must be deliberately limited (1 s) to avoid any damage that could prejudice future use. Using this approach will limit the trip threshold to a few milliamperes. It must not be considered that this test checks the intrinsic properties of the insulating materials. It is only the clearances that are validated.

Principle of measurement of the continuity resistance

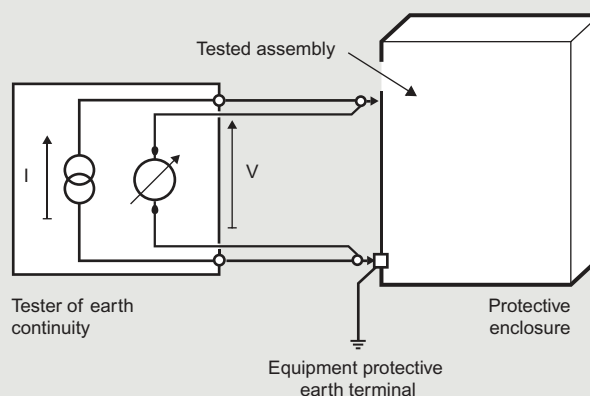

2 CHECKING THE CONTINUITY OF THE PROTECTIVE CIRCUITS

The structural provisions of XL³ enclosures directly provide continuity of the exposed conductive parts. It is however necessary to check that all the exposed conductive parts are effectively connected to the protective conductor of the assembly and that all the protective circuits are correctly interconnected via by the main terminal (or protective conductor collector).

2.1. Test conditions

- Measurement can be carried out in DC or AC
- The test voltage can be between 6 and 24 V
- One of the poles of the test source must be connected to the main terminal of the protective conductors, and the other (test key or test tongs) must be connected to the various elements.

2.2. Measurement of the continuity resistance

It is recommended that the following standard values are applied:

- Test current: 25 A
- Application time: 1 min
- Maximum resistance: 50 mΩ.

2.3. Checking the continuity with tester with signal

This procedure is not standardised. It is simply used to check that there is continuity, but does not assume its value. If it is applied, it must be accompanied by an increased visual check of each connection and element in the protective circuit.

For class I assemblies, this visual check covers the actual continuity between the exposed conductive parts, and between the exposed conductive parts and the protective conductor. For checking this link, the continuity is measured at 25 A.

The resistance must not exceed 50 mΩ.



The method used, measurement or checking, will be recorded on the individual inspection report. If other methods are used, for example those in standard EN 60204-1 (measurement of the voltage drop at 10 A), they must be specified.

Certification of assemblies (continued)

3 INSPECTION OF THE ASSEMBLY (VISUAL CHECK)

This operation includes the visual inspections that must be carried out

- Inspection of the mechanical elements: operation of locking systems, drawing out systems, closures, tightening torques, etc.
- Inspection of the wiring: cable entries, tightening of terminals, marking, etc.
- Marks and information on the assembly: nameplates, etc.
- Technical information provided
- Compliance with the degree of protection
- Checking the mounting distances
- Electrical operating tests
- Provisions for transport and handling (if necessary).

Standard IEC 60439-1 defines a non-exhaustive of requirements that must be dealt with specifically: climates, IP, accessibility, etc.

These must form the subject of an agreement between the manufacturer and the user.



Implementation ensures the safety of the distribution assemblies in accordance with good professional practice.

3.1. Conductors and wiring

- Compliance with the wiring diagram
- Cross-section of conductors
- Marking of the circuits (power, control, data)
- Identification of the conductors (colour, alphanumeric code)
- Marking of poles
- Identification of the load circuits (outgoing cables)
- Maintenance of the conductors
- Distance from sharp edges (sheet metal edges)
- Treatment of conductors not protected against short-circuits (steady circuits, measurements)
- Flexible links, clearance of conductors from removable parts (drawers, doors)
- Entry of conductors into the enclosure (seal, mechanical protection, no stresses)
- Layout of the busbars (mechanical hold, distances between supports, bolted connectors).

3.2. Wiring accessories

- Compliance of devices with the specified models (rating, type, breaking capacity, operating curves)
- Obtaining breaking capacity by combining devices (if necessary)
- Discrimination on specified circuits
- Nameplates and marks
- Positioning of connections (tightening, partitions, terminal covers)
- Crimping of lugs.

3.3. Measures for protection against electric shocks

> Protection against direct contact

- Presence of faceplates providing a degree of at least 2x or xxB
- Presence of screens (recommended) providing a degree of at least xxA
- Forms of internal separation (if required)
- Presence of "Live" warning labels.

> Protection against indirect contact

• Class I

Visual checking of the electrical connection of the chassis and structure of the assembly and the accessible metal parts:

- Presence of equipotential links on elements that are accessible (panels, doors) or can be drawn out
- Cross-section of equipotential links according to the power of the installed equipment
- Connection of protective conductors to the device terminals if provided
- Cross-section of protective conductors and main terminal.

NB: these provisions are checked by measuring the continuity (individual tests).

• Class II

Visual checking of the provisions specific to class II:

- Holding of conductors in the event of detachment
- Insulation of the exposed conductive parts and the protective conductors
- Non-connection of the exposed conductive parts to the protective conductor
- Routing of the conductors in ducting, or on isolating supports or use of class II conductors

- Reservation and identification of the areas treated as class II
 - Presence of the symbol O and warnings
 - No metal parts passing through the enclosure
 - Insulation of the wall fixings.
- NB: these provisions are checked by measuring the insulation or using a dielectric test (individual test).

3.4. Clearances

- Distances from the device connections (lugs, terminals for cable lugs, etc.) to the nearby exposed conductive parts (chassis, plate)
- Bolted connection and connection on the bars: distance between bars and with the exposed conductive part.

> Distances in the air

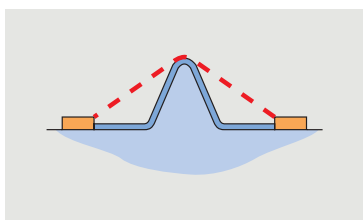

These represent the shortest distance between two conductive parts. If there is a breakdown that disrupts the air, the electric arc will follow this path. Ribs

or partitions can increase the distances in the air. The distances in the air are sized according to the U_{imp} voltage given for the assembly.

Impulse voltage U_{imp} (kV)	Minimum clearances (mm)	
	Between live parts with different polarity (P, N, bonding)	Between live parts and bonding with double or reinforced insulation
4	3	5.5
6	5.5	8
8	8	14
12	14	18

> Creepage distances

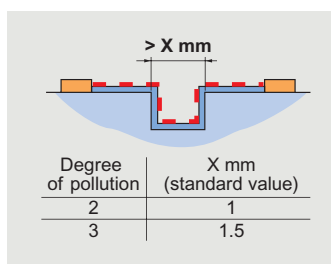

These represent the shortest distance along the surface of the insulating materials between two conductive parts. They depend on the properties of the insulating materials themselves and the

degree of pollution. Grooves and ribs can increase the creepage distance as long as they are large enough not to retain water. In practice and for the elements concerned, which are mainly connected with mounting, only grooves at least 2 mm wide and deep should be taken into account. The creepage distances are sized according to the insulation voltage U_i given for the assembly.

Insulation voltage U_i (V)	Minimum creepage distances in mm (material group II, RC > 4000)			
	Between live parts with different polarity (P, N, bonding)		Between live parts and bonding with double or reinforced insulation	
Degree of pollution	2	3	2	3
250	1.8	3.6	3.6	7.1
400	2.8	5.5	5.6	11
630/690	4.5	9	9	18
800	5.6	11	11	22
1000	7.1	14	14	28



Legrand supports and busbars are sized to provide double insulation in relation to the surrounding exposed conductive parts. Degree of pollution 2 can be selected for household, residential or commercial applications. Degree of pollution 3 must be chosen for industrial applications. XL³ IP 55 distribution enclosures with doors can be used to reduce the degree of pollution (for example from 3 to 2), creating a protected micro-environment.

Certification of assemblies (continued)



The required clearance values between live parts when there is double or reinforced insulation are based on standard IEC 60664-1 “Insulation coordination for equipment within low-voltage systems”:

- The distances in the air are determined for the impulse voltage immediately above the value given for voltage U_i
- The creepage distances are determined for a voltage value corresponding to double the given insulation voltage U_i . The double or reinforced insulation values must be applied upstream of the devices providing effective protection of people against indirect contact: residual current devices in TT system, short-circuit protection devices in IT and TN systems.

3.5. Mounting distances

Unlike clearances (distances in the air and creepage distances § 3.4) which are defined by the design of the devices, mounting distances are determined by the precautions taken at the installation stage (bolts between bars, custom supports, positions of lugs, etc.). The following minimum distances must be complied with for assemblies at 400 V:

- 10 mm between unprotected live parts with different polarity
- 20 mm between unprotected live parts and exposed conductive parts (chassis, enclosure).

This distance is increased to 100 mm if the enclosure does not have a protection level of at least xxB.

3.6. Electrical operation

If required by the complexity of the assembly, an operating test may be necessary. The location (workshop or site) must be defined by agreement between the parties, as well as the test conditions:

- Circuits tested
- Number points connected
- Lock positions
- Sequencing of commands
- Current measurement
- Phase balancing
- Tests of RCDs
- Measuring devices
- Etc.

3.7. Mechanical elements

- Locking and immobilisation
- Operation and closing of doors
- Presence of keys
- Coordination between locking and door of the room
- Draw-out and plug-in devices
- Mechanical safety of inverters
- Lifting devices (rings, brackets)
- Tightening torques
- Etc.

3.8. Degree of protection

- Maintenance of the degree of protection at the cable entries
- Links between assembled modules
- Sealing of doors, panels, openings
- Dust protection appropriate to the surrounding environment
- Protection of the ventilation or cooling devices
- Degree of accessibility to the energised internal parts (accessibility to informed people).
- Etc.

3.9. Marks and information

Presence of a visible nameplate containing at least:

- The name of the manufacturer of the assembly (or its trademark)
- The name of the type of assembly or information giving the corresponding technical details
- Etc.

3.10. Information in the technical documentation

The following information must be included on the nameplate or in the technical documentation.

- Reference to standard IEC 60439-1
- The current type and frequency
- The rated insulation voltages (U_i) and rated operating voltages (U_e) if they are different
- The rated impulse withstand voltages (U_{imp}) if they are indicated
- The voltages of the auxiliary circuits if necessary
- The operating limits
- The rated current (in Amperes) of each circuit

- The resistance to short-circuit currents: prospective rms current at the supply end of the assembly (in kA), the short-time withstand current (I_{sc} in kA), the permitted peak current (I_{pk} in kA)
- The IP degree of protection
- The class I or class II measures to protect people
- The connection of functional units (fixed, with front terminals, with rear terminals, draw-out, plug-in)

- The form of internal separation
- The operating conditions if they are different from the usual conditions (corrosive, tropical, dusty atmosphere)
- The type of neutral earthing system
- The dimensions (height x width x depth)
- The exposed conductive parts
- Etc.



< DMX³ supply inverter
in XL³ 4000 enclosure



Description of the types of electrical connections of functional units

The international standard IEC 60439-1 specifies the types of electrical connections of functional units within assemblies by a three-letter code.

The first letter denotes the type of electrical connection of the main incoming circuit.

The second letter denotes the type of electrical connection of the main outgoing circuit.

The third letter denotes the type of electrical connection of the auxiliary circuits.

The following letters shall be used:

- F for Fixed connections (removable with a tool: lugs, terminals ...)

- D for Disconnectable connections

- W for Withdrawable connections (the function associates auxiliary circuits and mechanical guidance of the unit).

Legrand's circuit breakers and protection devices offer provides answers to all levels from FFF to WWW with all possible variants.

Certification of assemblies (continued)

CHECKING ELECTROMAGNETIC COMPATIBILITY

Apart from standard assemblies designed for a specific use in a given environment, most assemblies that are manufactured singly incorporate a more or less random combination of equipment and components. Whether or not it will be necessary to check the electromagnetic compatibility will depend on the characteristics of the products that are incorporated and the installation rules that are followed.

No immunity or emission test is necessary if:

- The devices and components themselves comply with the EMC specifications applicable to them, or otherwise comply with the levels of the generic standards (IEC 61000-6-x series of standards). CE marking of products normally certifies this conformity if EMC requirements are applicable
- The installation and wiring have been carried out in accordance with the manufacturers' instructions. Information given in the book entitled "Protection against external disturbances", will enable this requirement to be met.



Test to check the EMC specifications are necessary if the assembly that has been created and the methods used do not comply with 1 and in particular when:

- The environment for which the assembly is intended has significant sources of disturbance or severe exposure conditions
- The assembly that is created incorporates sensitive electronic circuits (microprocessors) or circuits that produce disturbance (switching mode power supplies).



Tests to be carried out to check the EMC specifications

IMMUNITY TESTS

- 1.2/50 μ s - 8/20 μ s impulse waves in accordance with IEC 61000-4X:
 - Test level 2 kV: phase - earth/exposed conductive part
 - Test level 1 kV: between phases.
- Bursts of fast transients in accordance with IEC 61000-4-4:
 - Test level 2 kV.
- Radiated electromagnetic field in accordance with IEC 61000-4-3:
 - Test level 10 V/m.
- Electrostatic discharges in accordance with IEC 61000-4-2:
 - Test level 8 kV in air.

EMISSION TESTS

- Emission limits in accordance with CISPR 11:
 - Class B for household environments
 - Class A for industrial environments.



The presumed conformity of an assembly with the EMC requirements should not obscure the fact that a number of external disturbances, in particular those from the mains power supply, may create unacceptable malfunctions. For example: voltage fluctuations, short interruptions, the presence of harmonics, imbalances, etc. Likewise, the conditions for connecting the assembly to the installation must be taken into account. In this regard, the choice (or compulsory use) of the neutral earthing system may prove to be essential (see the Book 3 "Electrical energy supply").

MARKS AND INFORMATION

Finished assemblies must be visibly and durably marked with the following information:

- Mandatory presence of a nameplate indicating the manufacturer
- Presence, depending on contract, of a plate of label certifying compliance with standard IEC 60439-1/3 with the “transferred” number of the declaration of conformity
- Presence, if necessary, of a label with the CE mark.

**Assembly conforming
to standard IEC 60439-1/3**

Declaration no.

.....

< Example of a
conformity label
(min. recommended
dimensions:
50 x 30 mm)



Marking panels

Caution, the affixing of the CE mark is the sole responsibility of the manufacturer (assembler, panel builder) or the person or organisation responsible for placing it on the market.

In the event of checking or dispute, that organisation or person must be able to provide proof of compliance with the essential safety requirements in accordance with a preestablished reference system.

Standard IEC/EN 60439-1/3 is one of the reference standards used to check the requirements of the applicable directives:

- Low Voltage Directive (LVD) EEC/73/23 modified EEC/93/68
- Electromagnetic Compatibility Directive (EMC) 2004/108/EC.

Other directives:

- “Machinery” directive 98/37/EC
- “Work equipment” directive EEC/89/655
- “Communication terminals” directive 89/5/EC

These may be applicable from time to time or for certain parts of the assembly.



CE marking

CE marking has been rendered mandatory by the directives of the Council of the European Communities. The CE mark is not a quality mark; it does not apply to the functionality of the reliability of products.

It is simply a certification by the manufacturer (or the manufacturer’s representative) of compliance with the essential requirements of the directives applicable to the product in question. It is in fact a “passport” for the free circulation of goods in the European Union.

The situation of electrical panels and distribution assemblies is a little unusual in relation to these rules:

- On the one hand, they incorporate different equipment and devices, in very variable architectures
- On the other, they are often designed for a single use for the installation in question and are not generally available as a “commercial entity”.

Convention and “good sense” will show that panels specifically for one identified installation are not marked, as these products are not in free circulation. However, movable assemblies and prefabricated panels must be marked.



Min. height of letters: 5 mm
Dimensions to be adjusted
to size of assembly

Choice of products



200 45



200 54 + 201 60

XL³ 160 "READY TO USE" DISTRIBUTION CABINETS

		Cabinets and doors						
		Fully modular				Fully modular with DPX 160 space		
No of rows		2	3	4	5	6	4	5
No of modules		48	72	96	120	144	96	120
Wall mounting cabinets	Metal	200 02	200 03	200 04	200 05	200 06	200 45	200 46
	Insulating	200 52	200 53	200 54	200 55	200 56	-	-
Flush-mounting cabinets		-	200 13	200 14	200 15	200 16	-	-
Curved doors	Metal	202 52	202 53	202 54	202 55	202 56	202 55	202 56
	Metal	202 72	202 73	202 74	202 75	202 76	202 75	202 76
Flat doors	Glass	202 82	202 83	202 84	202 85	202 86	202 85	202 86

		Accessories		
		Metal	Insulating	Flush-mounting
Fixing accessories	Wall mounting lugs	201 00	201 50	-
	For hollow partition	-	-	200 10
Cable entry plates	Adjustable	200 20	-	-
	With knock-out entries	200 21	200 71	-
Cable fixing support		200 35	-	-
Finishing strip between DLP trunking and cabinet		201 60	201 60	-



200 13 + 202 83

Accessories (continued)

		Metal	Insulating	Flush-mounting
Support for IP 2X terminal blocks		-	200 50	-
Additional brass bar			373 00	
Flat bar 12 x 2			048 19	
Equipotential link conductor			373 85	
Wiring guides	For horizontal wiring		200 94	
	For vertical wiring		200 93	
Ducting support for Lina 25 ducting			200 70	
Seal for IP 43 protection			201 30	

Other accessories see p. 42-43

Dimensions

■ Metal and insulating cabinets

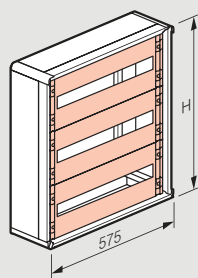

Cat.Nos	H (mm)
200 02	450
200 03	600
200 04	750
200 05	900
200 06	1050
200 45	900
200 46	1050
200 52	450
200 53	600
200 54	750
200 55	900
200 56	1050

With curved door (metal)

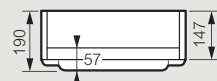

With flat door

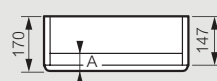

	A (mm)
Metal	38
Glass	34

■ Flush-mounting cabinets

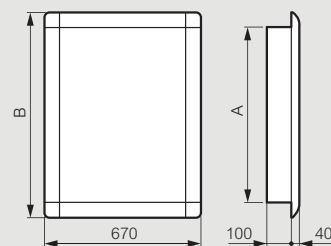

Cat.Nos	A (mm)	B (mm)
200 13	640	695
200 14	790	845
200 15/25	940	995
200 16/26	1090	1145



201 05



201 25



202 55



202 73



202 83

XL³ 400 METAL CABINETS AND ENCLOSURES







Cabinets, enclosures, cable sleeves and doors

Cabinet or enclosure	Face plate height (mm)	550	700	850	1000	1150	1450	1450	1750
	Cat.Nos	201 03	201 04	201 05	201 06	201 07	201 08	201 18	201 19
Curved doors	Metal	202 53	202 54	202 55	202 56	202 57	202 58	202 58	202 59
	Flat doors	Metal	202 73	202 74	202 75	202 76	202 77	202 78	202 78
Glass		202 83	202 84	202 85	202 86	202 87	202 88	202 88	202 89
External cable sleeves	Cat.Nos	201 23	201 24	201 25	201 26	201 27	201 28	201 38	201 39
	Flat doors	201 63	201 64	201 65	201 66	201 67	201 68	201 68	201 69

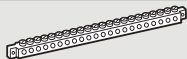
Accessories

			Cabinet and enclosures	Cable sleeves
Plinths			201 10	201 12
Wall mounting lugs			201 00	
Cable entry plates	Adjustable		201 20	-
	With knock-out entries		201 21	-
Cable fixing support			201 35	201 37
Insulating Support			200 90	-

Accessories (continued)

Additional brass bar		373 00
Equipotential link conductor		373 85
Wiring guides	For horizontal wiring 	200 94
	For vertical wiring 	201 93
Divider for horizontal compartments		201 90
Seal for IP 43 protection		201 30
Finishing strip between DLP and cabinet		201 60

Other accessories see p. 42-43

Dimensions

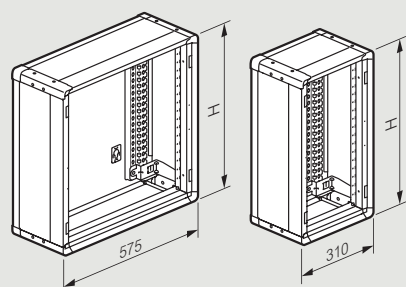

Cabinets Cat.Nos	Sleeves Cat.Nos	H (mm)
201 03	201 23	600
201 04	201 24	750
201 05	201 25	900
201 06	201 26	1050
201 07	201 27	1200
201 08	201 28	1500

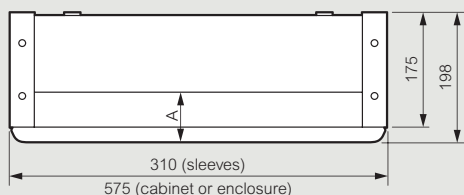

Doors	A (mm)
Metal	38
Glass	34

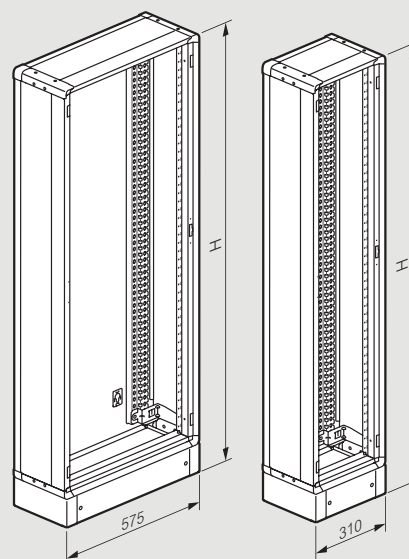
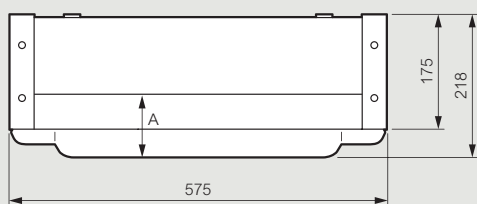

Enclosures Cat.Nos	Sleeves Cat.Nos	H (mm)
201 18	201 38	1600
201 19	201 39	1900



204 01



212 51



212 52





212 72

XL³ 800 CABINETS AND ENCLOSURES

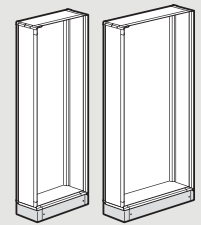
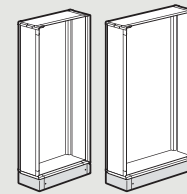
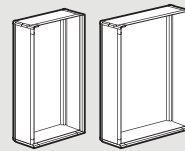
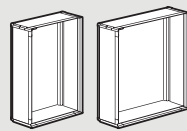
Cabinets, enclosures, cable sleeves and doors



IP 30-40-43

Cabinets or enclosures	Faceplate height (mm)	1000		1200		1400		1800	
	External width (mm)	660	910	660	910	660	910	660	910
	No modules per row	24	36	24	36	24	36	24	36
	Cat.Nos	204 01	204 06	204 02	204 07	204 03	204 08	204 04	204 09
Curved doors	Metal 	212 51	212 56	212 52	212 57	212 53	212 58	212 54	212 59
	Glass 	212 61	212 66	212 62	212 67	212 63	212 68	212 64	212 69
Internal cable sleeves	Cat.Nos	-	204 26	-	204 27	-	204 28	-	204 29
	Solid faceplates	-	204 46	-	204 47	-	204 48	-	204 49
External cable sleeves	Cat.Nos	-		-		204 23		204 24	
	Faceplates	-		-		204 43		204 44	
	Doors	-		-		204 33		204 34	

IP 55

Cabinets or enclosures	Faceplate height (mm)	1000		1200		1400		1800	
	External width (mm)	700	950	700	950	700	950	700	950
	No modules per row	24	36	24	36	24	36	24	36
	Cat.Nos	204 51	204 56	204 52	204 57	204 53	204 58	204 54	204 59
Flat doors	metal 	212 71	212 76	212 72	212 77	212 73	212 78	212 74	212 79
Internal cable sleeves	Cat.Nos	-	204 26	-	204 27	-	204 28	-	204 29
	Solid faceplates	-	204 46	-	204 47	-	204 48	-	204 49
External cable sleeves	Cat.Nos	-		-		204 73		204 74	
	Faceplates	-		-		204 43		204 44	
	Doors	-		-		204 83		204 84	
Side panels		204 66		204 67		204 68		204 69	

Accessories

		IP 30-40-43 enclosures			IP 55 enclosures		
		24 modules	36 modules	Cable sleeve	24 modules	36 modules	Cable sleeve
Wall mounting lugs		201 00			Supplied with the enclosure		
Plinths		204 10	204 11	204 12	204 60	204 61	204 62
Sealing kit IP 43 for doors		201 30			-		
Joining accessories	Joining kit	-			204 86		
	Sealing kit IP 55	-			205 85		
Adjustable cable entry plate		204 20			-		
Dividers for horizontal compartments		204 90	204 91	-	204 90	204 91	-

Other accessories see p. 42-43

Dimensions

Cabinets

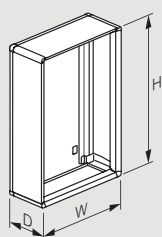

Cabinets with internal cable sleeve

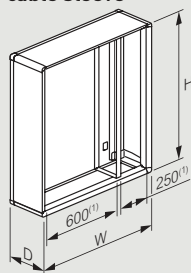

Enclosures and external cable sleeves

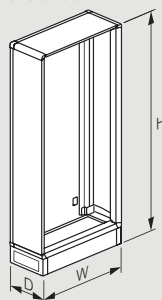

Enclosures with internal cable sleeve

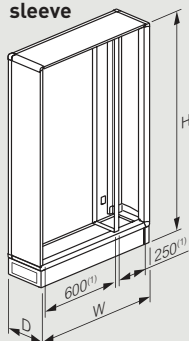

IP 30-40-43

Cat.Nos	External dimensions (mm)		
	W	H	D
Cabinets			
204 01	660	1050	230
204 02	660	1250	230
204 06	910	1050	230
204 07	910	1250	230
Enclosures			
204 03	660	1550	230
204 04	660	1950	230
204 08	910	1550	230
204 09	910	1950	230
External cable sleeves			
204 23	460	1550	230
204 24	460	1950	230

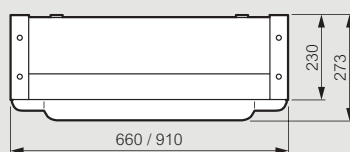

IP 55

Cat.Nos	External dimensions (mm)		
	W	H	D
Cabinets			
204 51	700	1095	225
204 52	700	1295	225
204 56	950	1095	225
204 57	950	1295	225
Enclosures			
204 53	700	1595	225
204 54	700	1995	225
204 58	950	1595	225
204 59	950	1995	225
External cable sleeves			
204 73	500	1595	225
204 74	500	1995	225

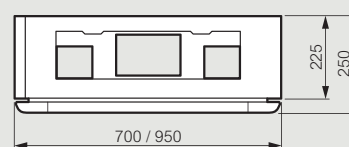









(1) usable width



Assembly consisting of:
 - Structural uprights Cat.No 205 00
 - "Roof-base" Cat.Nos 205 03/06/09
 - Plinths Cat.Nos 205 17/18/19
 - Functional uprights Cat.Nos 205 24/27
 - Intermediate structural uprights Cat.No 205 20

XL³ 4000 ENCLOSURES

Enclosures		"Roof-base" assemblies	Structural uprights	Plinths	Functional uprights	Faceplate supports		Internal cable sleeves crossspaces	Internal cable sleeves front covers	Rear panels	Side panels	Doors			
						fixed	pivoting					Curved Metal	Curved Glass	Flat Metal	Flat Glass
725 x 475 	2000	205 04	205 00	205 14	205 12	205 58	205 68	-	-	205 42	205 41	205 54	205 64	205 74	205 84
	2200		208 50		208 52	208 55	-			208 58	208 57	208 61	208 63	-	-
725 x 725 	2000	205 05	205 00	205 15	205 13	205 58	205 68	-	-	205 42	205 42	205 54	205 64	205 74	205 84
	2200		208 50		208 53	208 55	-			208 58	208 58	208 61	208 63	-	-
725 x 975 	2000	205 06	205 00	205 18	205 13	205 58	205 68	-	-	205 42	205 43	205 54	205 64	205 74	205 84
	2200		208 50		208 53	208 55	-			208 58	208 59	208 61	208 63	-	-
975 x 475 	2000	205 07	205 00	205 17	205 12	205 58	205 69	-	-	205 43	205 41	205 57	205 67	205 77	205 87
	2200		208 50		208 52	208 55	-			208 59	208 57	208 62	208 64	-	-
975 x 475 	2000	205 07	205 00	205 17	205 16	205 59	205 79	205 21	205 47	205 43	205 41	205 57	205 67	205 77	205 87
	2200		208 50		208 54	208 56	-			208 59	208 57	208 62	208 64	-	-
975 x 725 	2000	205 08	205 00	205 18	205 13	205 58	205 69	-	-	205 43	205 42	205 57	205 67	205 77	205 87
	2200		208 50		208 53	208 55	-			208 59	208 58	208 62	208 64	-	-
975 x 725 	2000	205 08	205 00	205 18	205 16	205 59	205 79	205 22	205 47	205 43	205 42	205 57	205 67	205 77	205 87
	2200		208 50		208 54	208 56	-			208 59	208 58	208 62	208 64	-	-
975 x 975 	2000	205 09	205 00	205 19	205 13	205 58	205 69	-	-	205 43	205 43	205 57	205 67	205 77	205 87
	2200		208 50		208 53	208 55	-			208 59	208 59	208 62	208 64	-	-
975 x 975 	2000	205 09	205 00	205 19	205 16	205 59	205 79	205 23	205 47	205 43	205 43	205 57	205 67	205 77	205 87
	2200		208 50		208 54	208 56	-			208 59	208 59	208 62	208 64	-	-

(1) with internal cable sleeve

External cable sleeves		"Roof-base" assemblies	Structural uprights	Plinths	Front covers	Rear panels	Side panels	Metal doors
Larg. x Prof. (mm)	Haut. (mm)							
475 x 475 	2000	205 01	205 00	205 11	205 48	205 41	205 41	205 71
	2200		208 50		208 67	208 57	208 57	208 65
475 x 725 	2000	205 02	205 00	205 14	205 48	205 41	205 42	205 71
	2200		208 50		208 67	208 57	208 58	208 65
475 x 975 	2000	205 03	205 00	205 17	205 48	205 41	205 43	205 71
	2200		208 50		208 67	208 57	208 59	208 65





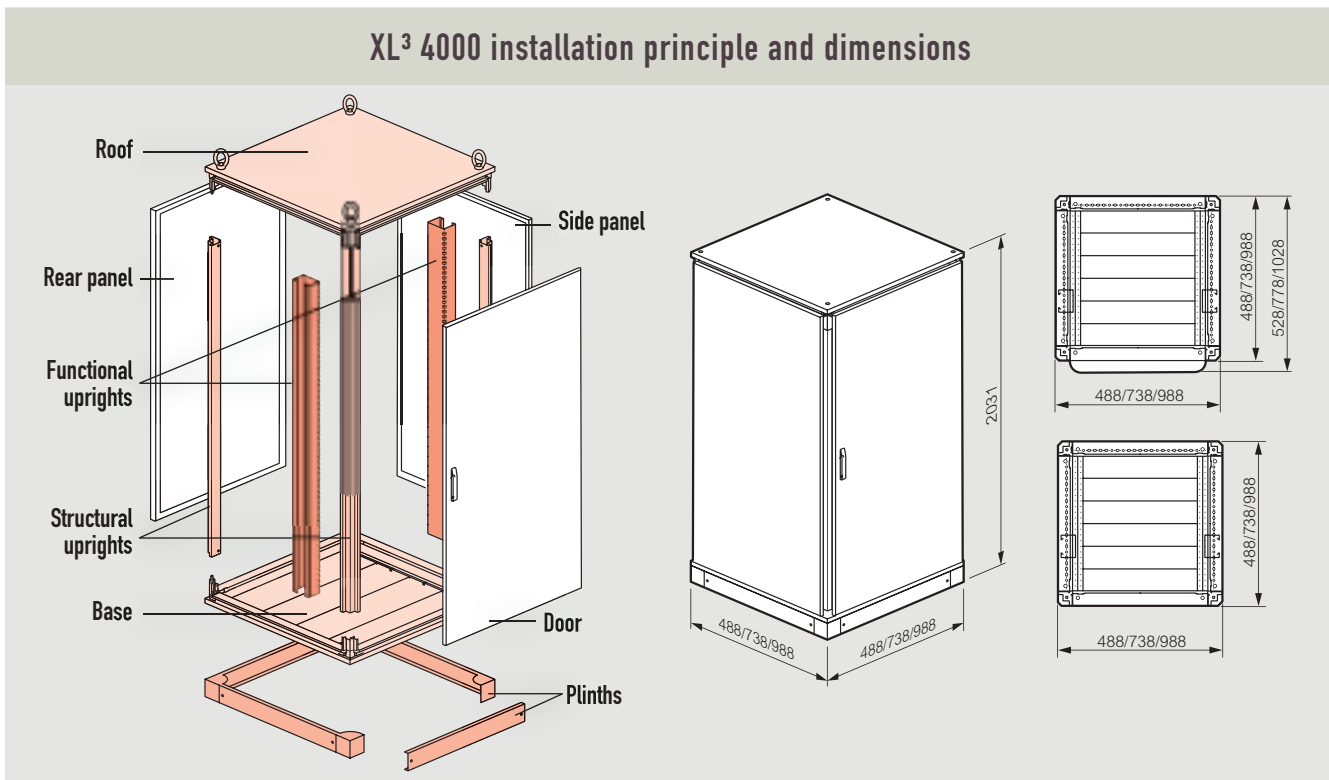

Accessories		
Joining accessories	Screws for structural joining	205 86
	L-shaped reinforcement plates	205 88
	Flat reinforcement plates	205 89
	Sealing kit IP 55	205 85
	Kit for joining plinths	205 10
Intermediate structural uprights	For height 2000 mm	205 20
	For height 2200 mm	208 51
Equipment for partial chassis	Fixing plates for reduced functional uprights	205 30
	Crosspieces length 350 mm	205 31
	Crosspieces length 600 mm	205 32
Fixed crosspieces for busbar support	Length 350 mm	205 51
	Length 600 mm	205 52
	Length 850 mm	205 53

Other accessories see p. 42-43

XL³ 4000 installation principle and dimensions

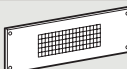
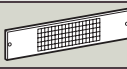

GENERAL ACCESSORIES

Accessories for faceplates		Enclosure width		Enclosure			
		24-mod.	36-mod.	XL ³ 160	XL ³ 400	XL ³ 800	XL ³ 4000
Blanking plate	24-module adjustable strip 	200 51		•	•	•	•
	18-module strip separable per 1/2 module 	016 65		•	•	•	•
Clip on holders for adhesive labels 		203 99		•	•	•	•
Hinges for screw mounting faceplates 		209 59				•	•
Accessories for natural ventilation							
Perforated faceplates height 200 mm 		209 49	209 99			•	•
Perforated panels for plinth 		205 44	205 45				•
Distance pieces for roof heightening 		205 46					•

Accessories for doors		24-mod.	36-mod.	XL ³ 160	XL ³ 400	XL ³ 800	XL ³ 4000
Key barrels	Type 405		202 91		•	•	•
	Type 455		202 92		•	•	•
	Type 1242E		202 93		•	•	•
	Type 2433A		202 94		•	•	•
Double bar knockout			202 96		•	•	•
Wiring accessories							
Ducting support for Lina 25 ducting			201 70	-		•	
			205 70	204 70			•
Plastic rivets for fixing Lina 25 ducting on functional uprights			200 80			•	•
Lina 25 ducting length 2 m	25 x 60 mm		362 02			•	•
	40 x 60 mm		362 07			•	•
	40 x 80 mm		362 08			•	•
	60 x 60 mm		362 12				•
	60 x 80 mm		362 13				•
Miscellaneous accessories							
Clip nuts for perforated plates	For M4 screws		364 40			•	•
	For M6 screws		364 41			•	•
Clip nuts for functional uprights for M6 screws			200 92			•	•
M6 screws			200 91			•	•
Lifting rings		204 82				• ⁽¹⁾	
		205 82					•
Lightning kit		203 89	-		•		
		209 89	-			•	•
RAL 7035 aerosol painting spray			200 98		•	•	•
Seal for cut-out protection on plates (20 m)			202 40			•	•

(1) only for IP55

! **Equipment for mounting breaking and protection devices**

To select fixing devices and faceplates, please consult Legrand catalogue or use XL Pro² software (see p. 13).

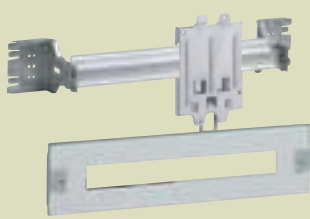

Fixing devices and faceplates for mounting on rail



Dedicated plates and faceplates

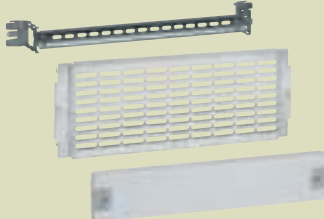

Universal rails and plates, solid faceplates



XL Pro² distribution panel design software

Annexes

HEAT DISSIPATION OF XL³ ENCLOSURES

The tables on the following pages give the power dissipated in the various enclosures of the XL³ range depending on their configuration (with or without a door, with seal, etc.) and their installation requirements.

The power dissipation is given for different values of average temperature rise of air inside the enclosure between 10 K and 40 K.

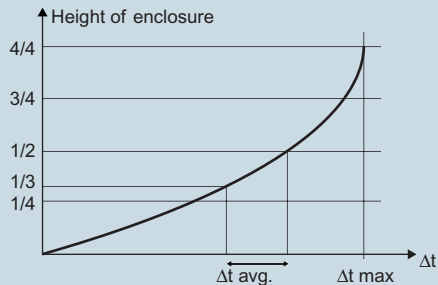

Δt avg. characterizes the arithmetic average value of the various heat values measured over the entire height of the envelope. The phenomenon of thermal gradient causes a greater rise in temperature in the upper part of the enclosure. It must be taken into consideration for thermal management and arrangement of equipment (see Book 8).

Installation requirements



The enclosure is placed on the ground, with no contact on any side (freestanding cabinets for example).

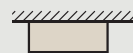

The back of the enclosure is up against a vertical surface (cabinet against a wall or wallmounted cabinet). All other sides are free.

The back of the enclosure is considered in contact if the distance between the enclosure and the vertical surface is less than 10 cm. Wallmounted cabinets should be installed at least 10 cm above the ground.



The back of the enclosure and one of the sides are in contact with a vertical surface (in a corner for example).

The enclosure is considered in contact if the distance between its back or sides and the vertical surfaces is less than 10 cm.

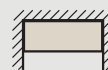

The back and both sides of the enclosure are in contact with a vertical surface (in a technical duct or a reserve for example).

The enclosure is considered in contact if the distance between its back or sides and the vertical surfaces is less than 10 cm.

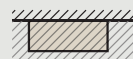

The back and top of the enclosure are in contact with a surface (against a wall and under the ceiling for example).

The enclosure is considered in contact if the distance between the top of the enclosure and the ceiling is less than 20 cm.

Caution: installing a rooftop air conditioner requires a clearance above the cabinet of at least 1 meter.

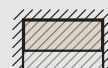

The back, sides and top of the enclosure are in contact with a surface (can be compared to a flush-mounted).

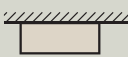
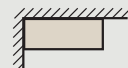
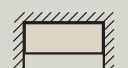
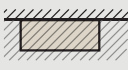
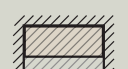

The above distance rules apply: less than 10 cm for vertical surfaces and less than 20 cm above the enclosure.

XL³ 160 metal cabinets

		IP 30 (without door)					IP 40 (with door)					IP 43 (with door and seal)				
Cat.Nos		200 02	200 03	200 04 200 45	200 05 200 46	200 06	200 02	200 03	200 04 200 45	200 05 200 46	200 06	200 02	200 03	200 04 200 45	200 05 200 46	200 06
Installation requirements ⁽¹⁾	Δt avg. (K)	Dissipated power (W)														
			10	25	32	39	46	52	23	29	34	40	46	20	25	30
	15	40	51	62	72	83	36	45	55	64	73	31	39	47	55	63
	20	57	71	86	101	116	51	64	77	90	102	44	55	67	78	89
	25	74	94	113	133	153	66	83	100	117	134	58	73	87	102	117
	30	93	118	143	167	192	83	105	126	148	169	73	91	110	128	147
	35	114	144	174	204	234	102	128	154	180	206	89	111	134	157	179
	40	136	172	207	243	279	121	153	184	215	246	106	133	160	187	214
	10	23	29	35	41	47	21	26	31	36	41	19	23	28	33	38
	15	37	46	56	65	75	33	41	49	57	66	30	37	45	52	60
	20	52	65	78	92	105	46	57	69	81	92	42	52	63	73	84
	25	68	85	103	121	138	60	75	91	106	121	55	68	82	96	110
	30	85	107	129	152	174	76	95	114	133	152	69	86	103	121	138
	35	104	131	158	185	212	92	116	139	162	185	84	105	126	147	168
	40	124	156	188	221	253	110	138	165	193	221	100	125	150	176	201
	10	21	26	32	37	43	19	23	28	32	37	18	22	26	31	35
	15	33	42	50	59	68	29	37	44	51	59	28	35	42	49	56
	20	47	59	71	83	95	41	52	62	72	82	39	49	59	69	78
	25	61	77	93	109	125	54	68	81	94	108	52	64	77	90	103
	30	77	97	117	137	157	68	85	102	119	136	65	81	97	113	129
	35	94	118	143	167	191	83	104	124	145	165	79	99	118	138	158
	40	112	141	170	199	228	99	124	148	173	197	94	118	141	165	188
	10	21	27	33	39	44	20	25	30	35	40	19	24	28	33	38
	15	34	43	52	61	70	31	39	47	55	63	30	37	45	53	60
	20	48	60	73	86	99	43	55	66	78	89	41	52	63	74	85
	25	62	79	96	113	129	57	72	87	102	117	54	69	83	97	111
	30	78	100	121	142	163	72	91	109	128	147	68	86	104	122	140
	35	96	121	147	173	198	88	110	133	156	179	83	105	127	149	171
	40	114	145	175	206	237	104	132	159	186	214	99	125	151	178	204
	10	19	24	29	34	40	17	21	25	30	34	17	21	25	30	34
	15	30	38	46	54	63	26	33	40	47	54	26	33	40	47	54
	20	42	53	65	76	88	37	47	56	66	76	37	47	56	66	76
	25	55	70	85	100	115	48	61	74	87	99	48	61	74	87	99
	30	69	88	107	126	145	61	77	93	109	125	61	77	93	109	125
	35	85	108	131	154	177	74	94	113	133	152	74	94	113	133	152
	40	101	128	156	183	211	88	112	135	158	182	88	112	135	158	182

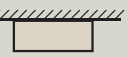
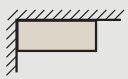
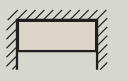
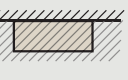

(1) See more details p. 44

Annexes (continued)



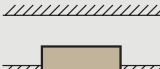
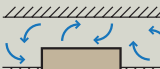

XL ³ 160 insulating cabinets																
Cat.Nos		IP 30 (without door)					IP 40 (with door)					IP 43 (with door and seal)				
Installation requirements ⁽¹⁾		200 52	200 53	200 54	200 55	200 56	200 52	200 53	200 54	200 55	200 56	200 52	200 53	200 54	200 55	200 56
Δt avg. (K)		Dissipated power (W)														
	10	23	29	35	41	47	20	25	31	36	41	18	22	27	31	36
	15	36	46	55	65	74	32	41	49	57	65	28	35	42	50	57
	20	51	64	78	91	105	46	57	69	81	92	40	50	60	70	80
	25	67	85	103	120	138	60	75	91	106	122	52	66	79	92	106
	30	85	107	130	152	175	76	95	115	134	154	66	83	100	117	134
	35	84	106	129	151	173	75	95	114	133	152	65	82	99	116	133
	40	124	157	190	223	256	111	140	168	197	225	97	122	146	171	196
	10	21	26	31	37	42	18	23	28	32	37	17	21	25	29	33
	15	33	41	50	59	67	29	37	44	51	59	27	33	40	47	53
	20	46	58	71	83	95	41	52	62	72	83	38	47	56	66	75
	25	61	77	93	109	125	54	68	82	96	109	49	62	74	87	99
	30	77	97	118	138	158	69	86	103	121	138	63	78	94	110	126
	35	77	97	117	137	157	68	85	103	120	137	62	78	93	109	125
	40	113	143	173	202	232	101	126	152	177	203	92	115	138	161	184
	10	19	24	28	33	38	17	21	25	29	33	16	20	24	27	31
	15	30	37	45	53	60	26	33	39	46	52	25	31	38	44	50
	20	42	53	64	75	85	37	46	56	65	74	35	44	53	62	70
	25	56	70	84	98	113	49	61	73	85	98	47	58	70	81	93
	30	70	88	106	124	142	62	77	93	108	123	59	74	88	103	117
	35	70	87	105	123	141	61	77	92	107	122	59	73	88	102	116
	40	103	129	156	182	209	91	113	136	158	181	87	108	129	151	172
	10	19	24	29	34	39	17	22	27	31	36	17	21	25	30	34
	15	30	38	47	55	63	28	35	42	50	57	26	33	40	47	54
	20	43	54	66	77	89	39	49	60	70	80	37	47	57	67	76
	25	56	72	87	102	117	52	65	79	92	106	49	62	75	88	101
	30	71	90	110	129	148	65	82	99	117	134	62	78	95	111	127
	35	71	90	109	128	147	65	82	99	116	132	62	78	94	110	126
	40	105	133	161	189	217	96	121	146	171	196	91	115	139	163	187
	10	17	21	26	31	35	15	19	23	26	30	15	19	23	26	30
	15	27	34	41	49	56	23	30	36	42	48	23	30	36	42	48
	20	38	48	58	69	79	33	42	51	59	68	33	42	51	59	68
	25	50	63	77	91	104	44	55	67	78	90	44	55	67	78	90
	30	63	80	97	115	132	55	70	84	99	114	55	70	84	99	114
	35	62	80	97	114	131	55	69	84	98	113	55	69	84	98	113
	40	92	118	143	168	193	81	102	124	145	167	81	102	124	145	167

(1) See more details p. 44

XL³ 160 flush-mounting cabinets

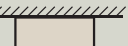
Cat.Nos		IP 40 (with door)				
		200 13	200 14	200 15	200 16	
Installation requirements		Δt avg. (K)	Dissipated power (W)			
 <p>The box is flush-mounted in a good heat insulator 0.04 W/m°C (glass wool, rock wool, polystyrene, etc.)</p>	10	19	24	28	32	
	15	32	39	45	52	
	20	46	56	65	75	
	25	61	75	88	101	
	30	79	96	112	129	
	35	98	119	140	161	
	40	118	144	169	194	
 <p>The box is flush-mounted in a medium heat insulator 0.4 W/m°C (plaster, wood, aerated concrete, hollow brick, etc.)</p>	10	26	32	37	43	
	15	42	50	59	68	
	20	59	71	84	96	
	25	78	94	111	127	
	30	99	119	140	161	
	35	121	146	172	197	
	40	145	175	206	236	
 <p>The box is flush-mounted in a poor insulator 2 W/m°C (stone, concrete, solid-brick, etc.)</p>	10	35	42	49	57	
	15	55	66	78	89	
	20	76	92	108	124	
	25	100	121	141	162	
	30	125	151	177	203	
	35	152	183	215	246	
	40	180	217	255	292	
 <p>The box is flush-mounted into a wall with lining (brick for plasterwork, plaster-tile, etc.) and unventilated crawl space</p>	10	27	33	39	45	
	15	44	53	62	72	
	20	62	75	88	102	
	25	82	99	117	134	
	30	104	126	148	170	
	35	127	154	181	208	
	40	153	185	217	250	
 <p>The box is flush-mounted into a wall with lining and ventilated crawl space</p>	10	36	44	51	59	
	15	57	70	82	94	
	20	81	99	116	134	
	25	107	131	154	177	
	30	136	165	195	224	
	35	167	203	239	275	
	40	200	244	287	330	

Annexes (continued)

XL ³ 400 metal cabinets and enclosures															
		IP 30 (without door)													
		without cable sleeve							with cable sleeve						
Cat.Nos		201 03	201 04	201 05	201 06	201 07	201 08/18	201 19	201 03 + 201 23	201 04 + 201 24	201 05 + 201 25	201 06 + 201 26	201 07 + 201 27	201 08/18 + 201 28/38	201 19 + 201 39
Installation requirements ⁽¹⁾	Δt avg. (K)	Dissipated power (W)													
			10	34	41	48	55	63	77	91	49	59	68	78	88
	15	54	66	77	88	99	121	144	77	93	108	124	139	170	201
	20	76	92	108	123	139	170	201	109	130	152	174	196	239	283
	25	100	121	141	162	182	223	264	142	171	200	228	257	314	371
	30	126	152	178	203	229	281	332	179	215	251	287	323	395	467
	35	154	185	217	248	280	343	405	218	262	306	350	394	481	569
	40	183	221	258	296	333	409	484	260	313	365	417	470	574	679
	10	31	37	44	50	56	69	81	45	54	63	72	81	98	116
	15	49	59	69	79	89	109	129	71	85	99	113	128	156	184
	20	69	83	97	111	125	153	181	100	120	139	159	179	219	258
	25	91	109	127	146	164	200	237	131	157	183	209	235	287	339
	30	114	137	160	183	206	252	298	165	197	230	263	295	361	426
	35	139	167	195	223	251	307	363	201	241	281	320	360	440	520
	40	166	199	233	266	300	366	433	239	287	335	382	430	525	620
	10	28	33	39	45	50	61	72	41	49	57	65	73	90	106
	15	44	53	62	71	79	97	115	65	78	91	103	116	142	167
	20	62	74	87	99	111	136	161	91	109	127	145	163	199	235
	25	81	98	114	130	146	179	211	120	143	167	191	214	261	308
	30	102	123	143	163	184	225	265	151	180	210	240	269	329	388
	35	125	150	175	199	224	274	324	184	220	256	292	328	401	473
	40	149	179	208	238	267	327	386	219	262	305	349	392	478	564
	10	30	36	43	49	56	69	81	42	51	60	69	78	96	114
	15	47	58	68	78	88	108	129	67	81	95	110	124	152	180
	20	67	81	95	109	124	152	181	94	114	134	154	174	214	253
	25	87	106	125	144	162	200	237	124	150	176	202	228	280	332
	30	110	133	157	181	204	251	298	155	188	221	254	287	352	418
	35	134	163	191	220	249	306	364	190	230	270	310	350	430	510
	40	160	194	228	263	297	365	434	226	274	322	369	417	512	608
	10	25	31	36	41	46	57	68	37	45	52	60	68	83	99
	15	40	48	57	65	73	90	107	59	71	83	95	107	132	156
	20	56	68	80	91	103	127	150	82	99	117	134	151	185	219
	25	74	89	104	120	135	166	197	108	131	153	175	198	243	288
	30	93	112	131	151	170	209	248	136	164	192	221	249	305	362
	35	113	137	160	184	208	255	302	166	200	235	269	303	372	441
	40	135	163	191	219	247	304	360	198	239	280	321	362	444	526



(1) See more details p. 44

XL³ 400 metal cabinets and enclosures

		IP 40 (with door)													
		Without cable sleeve							With cable sleeve						
Cat.Nos		201 03	201 04	201 05	201 06	201 07	201 08/18	201 19	201 03 +	201 04 +	201 05 +	201 06 +	201 07 +	201 08/18 +	201 19 +
		201 23	201 24	201 25	201 26	201 27	201 28/38	201 39							
Installation requirements ⁽¹⁾	Δt avg. (K)	Dissipated power (W)													
			10	31	37	43	49	55	68	80	43	52	60	69	77
15	49		59	68	78	88	107	127	69	82	95	109	122	149	175
20	68		82	96	109	123	150	178	96	115	134	152	171	209	246
25	90		108	126	144	162	197	233	126	151	176	200	225	274	323
30	113		136	158	181	203	248	293	159	190	221	252	282	344	406
35	138		165	193	220	248	303	358	194	231	269	307	345	420	495
40	164		197	230	263	295	361	426	231	276	321	366	411	501	591
	10	28	33	38	44	49	60	71	40	47	55	62	70	85	100
	15	44	52	61	70	78	95	112	63	75	87	99	111	135	159
	20	61	74	86	98	110	134	158	88	105	122	139	156	189	223
	25	81	96	112	128	144	176	207	116	138	160	182	204	249	293
	30	101	121	141	161	181	221	260	145	173	201	229	257	313	368
	35	124	148	172	196	221	269	318	177	211	245	279	313	381	449
	40	148	176	205	234	263	321	379	211	252	292	333	374	455	536
	10	25	29	34	39	44	53	63	36	43	50	57	63	77	91
	15	39	47	54	62	69	84	99	57	68	79	90	100	122	144
	20	55	65	76	86	97	118	139	80	95	111	126	141	171	202
	25	72	86	100	113	127	155	183	105	125	145	165	185	225	265
	30	90	108	125	143	160	195	229	132	157	182	207	232	283	333
	35	110	132	153	174	195	237	280	161	192	222	253	284	345	406
	40	132	157	182	207	233	283	334	192	229	265	302	338	411	484
	10	27	32	38	44	49	60	72	37	45	53	60	68	84	99
	15	42	51	60	69	78	96	113	59	71	84	96	108	132	157
	20	59	72	84	97	109	134	159	83	100	117	134	151	186	220
	25	78	94	111	127	143	176	209	109	131	154	176	199	244	289
	30	98	119	139	160	180	221	262	137	165	193	222	250	306	363
	35	119	145	170	195	220	270	320	167	202	236	270	305	374	442
	40	142	172	202	232	262	322	382	199	240	281	322	363	446	528
	10	22	27	31	36	40	49	58	32	39	45	52	58	71	84
	15	35	42	49	56	64	78	92	51	61	72	82	92	113	133
	20	49	59	69	79	89	109	129	72	86	101	115	130	158	187
	25	65	78	91	104	117	144	170	94	113	132	151	170	208	246
	30	81	98	114	131	147	180	214	118	142	166	190	214	261	309
	35	99	119	139	160	180	220	260	144	173	203	232	261	319	377
	40	118	142	166	190	214	262	311	172	207	242	276	311	380	450

(1) See more details p. 44

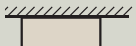
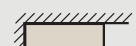
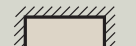
Annexes (continued)

XL ³ 400 metal cabinets and enclosures															
		IP 43 (with door and seal)													
		without cable sleeve							with cable sleeve						
Cat.Nos		201 03	201 04	201 05	201 06	201 07	201 08/18	201 19	201 03 + 201 23	201 04 + 201 24	201 05 + 201 25	201 06 + 201 26	201 07 + 201 27	201 08/18 + 201 28/38	201 19 + 201 39
Installation requirements ⁽¹⁾	Δt avg. (K)	Dissipated power (W)													
			10	27	32	37	43	48	59	70	38	45	52	60	67
	15	42	51	59	68	76	93	110	60	71	83	94	106	129	152
	20	60	71	83	95	107	131	155	84	100	116	133	149	181	214
	25	78	94	109	125	140	172	203	110	131	153	174	195	238	281
	30	98	118	137	157	177	216	255	138	165	192	219	246	299	353
	35	120	144	168	192	215	263	311	169	201	234	267	300	365	431
	40	143	171	200	228	257	314	371	201	240	279	318	357	435	514
	10	25	30	35	40	45	55	65	36	43	50	57	64	78	91
	15	40	48	55	63	71	87	102	57	68	79	90	101	123	145
	20	56	67	78	89	100	122	143	80	95	111	126	142	172	203
	25	73	88	102	116	131	160	188	105	125	145	166	186	226	266
	30	92	110	128	146	164	201	237	132	157	183	208	234	284	335
	35	112	134	157	179	201	245	289	161	192	223	254	285	347	409
	40	134	160	187	213	239	292	344	192	229	266	303	340	413	487
	10	23	28	33	37	42	51	60	34	41	47	54	60	73	86
	15	37	44	51	59	66	80	94	54	65	75	85	96	116	137
	20	52	62	72	82	92	112	132	76	91	105	120	134	163	192
	25	69	82	95	108	121	148	174	100	119	138	157	176	214	252
	30	86	103	119	136	152	185	219	126	150	174	198	221	269	317
	35	105	125	145	166	186	226	267	154	183	212	241	270	328	386
	40	125	149	173	198	222	270	318	183	218	253	287	322	391	461
	10	25	31	36	41	47	57	68	36	43	50	58	65	80	94
	15	40	49	57	66	74	91	108	56	68	80	91	103	126	149
	20	57	68	80	92	104	128	151	79	95	112	128	144	177	209
	25	74	90	105	121	137	168	199	104	125	147	168	189	232	275
	30	93	113	132	152	172	211	250	130	157	184	211	238	292	345
	35	114	138	162	185	209	257	305	159	192	225	257	290	356	421
	40	136	164	193	221	250	307	364	190	229	268	307	346	424	502
	10	22	27	31	36	40	49	58	32	39	45	52	58	71	84
	15	35	42	49	56	64	78	92	51	61	72	82	92	113	133
	20	49	59	69	79	89	109	129	72	86	101	115	130	158	187
	25	65	78	91	104	117	144	170	94	113	132	151	170	208	246
	30	81	98	114	131	147	180	214	118	142	166	190	214	261	309
	35	99	119	139	160	180	220	260	144	173	203	232	261	319	377
	40	118	142	166	190	214	262	311	172	207	242	276	311	380	450











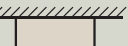

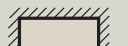

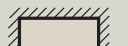

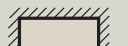
(1) See more details p. 44

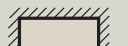
XL³ 800 metal cabinets and enclosures

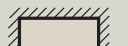
		IP 30 (without door)											
		without cable sleeve								with cable sleeve			
Cat.Nos		204 01	204 02	204 06	204 07	204 03	204 04	204 08	204 09	204 03 + 204 23	204 04 + 204 24	204 08 + 204 23	204 09 + 204 24
Installation requirements ⁽¹⁾	Δt avg. (K)	Dissipated power (W)											
	10	68	79	87	102	91	113	116	144	137	170	162	201
	15	108	126	138	161	143	179	183	228	217	269	256	319
	20	151	176	194	226	201	251	257	320	304	378	360	447
	25	199	231	255	296	264	329	337	420	399	496	472	587
	30	250	291	320	372	332	414	424	528	502	624	594	738
	35	305	355	391	454	405	505	517	644	612	761	724	900
	40	364	423	466	541	483	602	617	768	730	907	864	1073
	10	61	71	79	92	81	101	105	130	125	155	149	185
	15	97	112	126	146	128	159	166	206	198	246	236	293
	20	136	158	176	205	180	224	233	290	278	345	331	411
	25	178	207	232	269	236	294	306	380	365	453	435	540
	30	224	260	291	338	296	369	385	478	459	570	547	679
	35	273	317	355	412	361	450	469	583	559	695	667	828
	40	325	378	423	491	431	537	559	695	667	829	795	987
	10	54	63	72	83	72	89	95	117	114	141	137	170
	15	86	100	114	132	113	141	150	186	180	224	217	269
	20	121	140	159	185	159	198	210	261	253	314	304	377
	25	158	184	209	243	209	260	276	342	332	412	399	495
	30	199	231	263	305	263	326	347	431	418	518	502	622
	35	243	282	321	372	320	398	423	525	509	632	612	759
	40	289	336	383	444	382	475	505	626	607	753	730	905
	10	60	70	77	90	81	101	103	129	121	152	143	179
	15	95	111	122	142	127	160	163	203	192	240	227	284
	20	134	156	171	199	179	224	228	286	269	337	319	398
	25	175	205	224	262	235	294	299	375	354	442	418	523
	30	220	258	282	329	295	370	376	471	445	556	526	657
	35	269	314	343	401	360	451	459	575	542	678	641	802
	40	320	375	410	479	429	538	548	685	647	809	765	956
	10	50	58	66	76	66	83	87	109	105	131	126	157
	15	79	92	104	121	105	131	138	173	166	208	200	249
	20	110	129	146	170	147	184	194	242	233	291	280	350
	25	145	169	191	223	193	241	255	318	306	382	368	459
	30	182	212	240	280	243	303	320	400	385	481	462	577
	35	222	259	293	342	296	370	390	487	469	586	564	704
	40	265	309	349	407	353	441	465	581	560	699	672	839

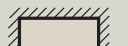
(1) See more details p. 44

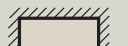
Annexes (continued)

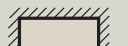
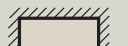
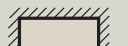
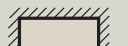
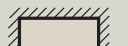
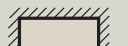
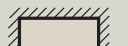
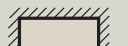
XL ³ 800 metal cabinets and enclosures																																																																																																																																																																																																																																																																																																																																																																																																																																																																																																									
		IP 40 (with door)																																																																																																																																																																																																																																																																																																																																																																																																																																																																																																							
		without cable sleeve								with cable sleeve																																																																																																																																																																																																																																																																																																																																																																																																																																																																																															
Cat.Nos		204 01	204 02	204 06	204 07	204 03	204 04	204 08	204 09	204 03 + 204 23	204 04 + 204 24	204 08 + 204 23	204 09 + 204 24																																																																																																																																																																																																																																																																																																																																																																																																																																																																																												
Installation requirements ⁽¹⁾	Δt avg. (K)	Dissipated power (W)																																																																																																																																																																																																																																																																																																																																																																																																																																																																																																							
			10	61	71	77	90	81	100	102	127	120	149	141	175		15	97	112	123	142	128	159	162	200	190	235	224	277		20	136	157	172	199	179	223	227	281	267	330	314	389		25	178	207	226	262	235	292	298	369	350	434	412	510		30	224	260	284	329	296	368	374	464	440	545	518	642		35	273	317	346	401	361	448	456	566	537	665	632	783		40	325	378	413	479	430	535	544	675	640	793	754	933		10	54	63	70	81	71	89	92	114	109	135	129	160		15	86	99	111	128	113	140	145	180	173	214	205	253		20	120	139	155	180	159	197	204	253	242	300	288	356		25	158	183	204	236	208	258	268	332	318	393	378	467		30	199	230	256	297	262	325	337	417	400	494	475	587		35	242	281	313	362	319	396	411	509	487	603	579	716		40	289	335	373	431	381	472	490	606	581	719	690	853		10	48	55	63	72	63	77	82	102	99	122	118	146		15	76	87	99	115	99	123	130	161	156	193	187	231		20	106	123	139	161	139	172	183	226	219	270	262	324		25	139	161	183	211	183	226	240	296	287	355	344	425		30	175	202	230	266	230	284	301	372	361	446	433	534		35	213	247	281	324	280	347	367	454	441	544	528	652		40	254	294	335	386	334	413	438	541	526	649	630	777		10	54	63	68	79	71	89	90	113	106	132	125	155		15	85	99	107	125	113	142	143	178	168	209	197	246		20	119	139	151	176	159	199	200	250	235	294	277	345		25	156	182	198	230	208	261	263	328	309	385	364	453		30	196	229	248	290	262	328	331	413	388	484	457	569		35	239	280	303	353	320	400	403	504	474	591	557	695		40	286	333	361	421	381	477	481	601	565	705	665	828		10	43	50	57	66	58	72	75	94	90	112	108	135		15	69	80	90	105	91	114	119	149	143	178	171	213		20	96	112	127	147	128	159	168	209	201	250	240	299		25	127	147	166	193	168	209	220	274	264	328	316	392		30	159	185	209	243	211	263	276	344	331	412	397	493		35	194	226	255	296	257	321	337	420	404	503	484	602		40	231	269	304	353	307	383	402	501	482	600
	15	97	112	123	142	128	159	162	200	190	235	224	277		20	136	157	172	199	179	223	227	281	267	330	314	389		25	178	207	226	262	235	292	298	369	350	434	412	510		30	224	260	284	329	296	368	374	464	440	545	518	642		35	273	317	346	401	361	448	456	566	537	665	632	783		40	325	378	413	479	430	535	544	675	640	793	754	933		10	54	63	70	81	71	89	92	114	109	135	129	160		15	86	99	111	128	113	140	145	180	173	214	205	253		20	120	139	155	180	159	197	204	253	242	300	288	356		25	158	183	204	236	208	258	268	332	318	393	378	467		30	199	230	256	297	262	325	337	417	400	494	475	587		35	242	281	313	362	319	396	411	509	487	603	579	716		40	289	335	373	431	381	472	490	606	581	719	690	853		10	48	55	63	72	63	77	82	102	99	122	118	146		15	76	87	99	115	99	123	130	161	156	193	187	231		20	106	123	139	161	139	172	183	226	219	270	262	324		25	139	161	183	211	183	226	240	296	287	355	344	425		30	175	202	230	266	230	284	301	372	361	446	433	534		35	213	247	281	324	280	347	367	454	441	544	528	652		40	254	294	335	386	334	413	438	541	526	649	630	777		10	54	63	68	79	71	89	90	113	106	132	125	155		15	85	99	107	125	113	142	143	178	168	209	197	246		20	119	139	151	176	159	199	200	250	235	294	277	345		25	156	182	198	230	208	261	263	328	309	385	364	453		30	196	229	248	290	262	328	331	413	388	484	457	569		35	239	280	303	353	320	400	403	504	474	591	557	695		40	286	333	361	421	381	477	481	601	565	705	665	828		10	43	50	57	66	58	72	75	94	90	112	108	135		15	69	80	90	105	91	114	119	149	143	178	171	213		20	96	112	127	147	128	159	168	209	201	250	240	299		25	127	147	166	193	168	209	220	274	264	328	316	392		30	159	185	209	243	211	263	276	344	331	412	397	493		35	194	226	255	296	257	321	337	420	404	503	484	602		40	231	269	304	353	307	383	402	501	482	600	577	717														
	20	136	157	172	199	179	223	227	281	267	330	314	389		25	178	207	226	262	235	292	298	369	350	434	412	510		30	224	260	284	329	296	368	374	464	440	545	518	642		35	273	317	346	401	361	448	456	566	537	665	632	783		40	325	378	413	479	430	535	544	675	640	793	754	933		10	54	63	70	81	71	89	92	114	109	135	129	160		15	86	99	111	128	113	140	145	180	173	214	205	253		20	120	139	155	180	159	197	204	253	242	300	288	356		25	158	183	204	236	208	258	268	332	318	393	378	467		30	199	230	256	297	262	325	337	417	400	494	475	587		35	242	281	313	362	319	396	411	509	487	603	579	716		40	289	335	373	431	381	472	490	606	581	719	690	853		10	48	55	63	72	63	77	82	102	99	122	118	146		15	76	87	99	115	99	123	130	161	156	193	187	231		20	106	123	139	161	139	172	183	226	219	270	262	324		25	139	161	183	211	183	226	240	296	287	355	344	425		30	175	202	230	266	230	284	301	372	361	446	433	534		35	213	247	281	324	280	347	367	454	441	544	528	652		40	254	294	335	386	334	413	438	541	526	649	630	777		10	54	63	68	79	71	89	90	113	106	132	125	155		15	85	99	107	125	113	142	143	178	168	209	197	246		20	119	139	151	176	159	199	200	250	235	294	277	345		25	156	182	198	230	208	261	263	328	309	385	364	453		30	196	229	248	290	262	328	331	413	388	484	457	569		35	239	280	303	353	320	400	403	504	474	591	557	695		40	286	333	361	421	381	477	481	601	565	705	665	828		10	43	50	57	66	58	72	75	94	90	112	108	135		15	69	80	90	105	91	114	119	149	143	178	171	213		20	96	112	127	147	128	159	168	209	201	250	240	299		25	127	147	166	193	168	209	220	274	264	328	316	392		30	159	185	209	243	211	263	276	344	331	412	397	493		35	194	226	255	296	257	321	337	420	404	503	484	602		40	231	269	304	353	307	383	402	501	482	600	577	717																												
	25	178	207	226	262	235	292	298	369	350	434	412	510		30	224	260	284	329	296	368	374	464	440	545	518	642		35	273	317	346	401	361	448	456	566	537	665	632	783		40	325	378	413	479	430	535	544	675	640	793	754	933		10	54	63	70	81	71	89	92	114	109	135	129	160		15	86	99	111	128	113	140	145	180	173	214	205	253		20	120	139	155	180	159	197	204	253	242	300	288	356		25	158	183	204	236	208	258	268	332	318	393	378	467		30	199	230	256	297	262	325	337	417	400	494	475	587		35	242	281	313	362	319	396	411	509	487	603	579	716		40	289	335	373	431	381	472	490	606	581	719	690	853		10	48	55	63	72	63	77	82	102	99	122	118	146		15	76	87	99	115	99	123	130	161	156	193	187	231		20	106	123	139	161	139	172	183	226	219	270	262	324		25	139	161	183	211	183	226	240	296	287	355	344	425		30	175	202	230	266	230	284	301	372	361	446	433	534		35	213	247	281	324	280	347	367	454	441	544	528	652		40	254	294	335	386	334	413	438	541	526	649	630	777		10	54	63	68	79	71	89	90	113	106	132	125	155		15	85	99	107	125	113	142	143	178	168	209	197	246		20	119	139	151	176	159	199	200	250	235	294	277	345		25	156	182	198	230	208	261	263	328	309	385	364	453		30	196	229	248	290	262	328	331	413	388	484	457	569		35	239	280	303	353	320	400	403	504	474	591	557	695		40	286	333	361	421	381	477	481	601	565	705	665	828		10	43	50	57	66	58	72	75	94	90	112	108	135		15	69	80	90	105	91	114	119	149	143	178	171	213		20	96	112	127	147	128	159	168	209	201	250	240	299		25	127	147	166	193	168	209	220	274	264	328	316	392		30	159	185	209	243	211	263	276	344	331	412	397	493		35	194	226	255	296	257	321	337	420	404	503	484	602		40	231	269	304	353	307	383	402	501	482	600	577	717																																										
	30	224	260	284	329	296	368	374	464	440	545	518	642		35	273	317	346	401	361	448	456	566	537	665	632	783		40	325	378	413	479	430	535	544	675	640	793	754	933		10	54	63	70	81	71	89	92	114	109	135	129	160		15	86	99	111	128	113	140	145	180	173	214	205	253		20	120	139	155	180	159	197	204	253	242	300	288	356		25	158	183	204	236	208	258	268	332	318	393	378	467		30	199	230	256	297	262	325	337	417	400	494	475	587		35	242	281	313	362	319	396	411	509	487	603	579	716		40	289	335	373	431	381	472	490	606	581	719	690	853		10	48	55	63	72	63	77	82	102	99	122	118	146		15	76	87	99	115	99	123	130	161	156	193	187	231		20	106	123	139	161	139	172	183	226	219	270	262	324		25	139	161	183	211	183	226	240	296	287	355	344	425		30	175	202	230	266	230	284	301	372	361	446	433	534		35	213	247	281	324	280	347	367	454	441	544	528	652		40	254	294	335	386	334	413	438	541	526	649	630	777		10	54	63	68	79	71	89	90	113	106	132	125	155		15	85	99	107	125	113	142	143	178	168	209	197	246		20	119	139	151	176	159	199	200	250	235	294	277	345		25	156	182	198	230	208	261	263	328	309	385	364	453		30	196	229	248	290	262	328	331	413	388	484	457	569		35	239	280	303	353	320	400	403	504	474	591	557	695		40	286	333	361	421	381	477	481	601	565	705	665	828		10	43	50	57	66	58	72	75	94	90	112	108	135		15	69	80	90	105	91	114	119	149	143	178	171	213		20	96	112	127	147	128	159	168	209	201	250	240	299		25	127	147	166	193	168	209	220	274	264	328	316	392		30	159	185	209	243	211	263	276	344	331	412	397	493		35	194	226	255	296	257	321	337	420	404	503	484	602		40	231	269	304	353	307	383	402	501	482	600	577	717																																																								
	35	273	317	346	401	361	448	456	566	537	665	632	783		40	325	378	413	479	430	535	544	675	640	793	754	933		10	54	63	70	81	71	89	92	114	109	135	129	160		15	86	99	111	128	113	140	145	180	173	214	205	253		20	120	139	155	180	159	197	204	253	242	300	288	356		25	158	183	204	236	208	258	268	332	318	393	378	467		30	199	230	256	297	262	325	337	417	400	494	475	587		35	242	281	313	362	319	396	411	509	487	603	579	716		40	289	335	373	431	381	472	490	606	581	719	690	853		10	48	55	63	72	63	77	82	102	99	122	118	146		15	76	87	99	115	99	123	130	161	156	193	187	231		20	106	123	139	161	139	172	183	226	219	270	262	324		25	139	161	183	211	183	226	240	296	287	355	344	425		30	175	202	230	266	230	284	301	372	361	446	433	534		35	213	247	281	324	280	347	367	454	441	544	528	652		40	254	294	335	386	334	413	438	541	526	649	630	777		10	54	63	68	79	71	89	90	113	106	132	125	155		15	85	99	107	125	113	142	143	178	168	209	197	246		20	119	139	151	176	159	199	200	250	235	294	277	345		25	156	182	198	230	208	261	263	328	309	385	364	453		30	196	229	248	290	262	328	331	413	388	484	457	569		35	239	280	303	353	320	400	403	504	474	591	557	695		40	286	333	361	421	381	477	481	601	565	705	665	828		10	43	50	57	66	58	72	75	94	90	112	108	135		15	69	80	90	105	91	114	119	149	143	178	171	213		20	96	112	127	147	128	159	168	209	201	250	240	299		25	127	147	166	193	168	209	220	274	264	328	316	392		30	159	185	209	243	211	263	276	344	331	412	397	493		35	194	226	255	296	257	321	337	420	404	503	484	602		40	231	269	304	353	307	383	402	501	482	600	577	717																																																																						
	40	325	378	413	479	430	535	544	675	640	793	754	933		10	54	63	70	81	71	89	92	114	109	135	129	160		15	86	99	111	128	113	140	145	180	173	214	205	253		20	120	139	155	180	159	197	204	253	242	300	288	356		25	158	183	204	236	208	258	268	332	318	393	378	467		30	199	230	256	297	262	325	337	417	400	494	475	587		35	242	281	313	362	319	396	411	509	487	603	579	716		40	289	335	373	431	381	472	490	606	581	719	690	853		10	48	55	63	72	63	77	82	102	99	122	118	146		15	76	87	99	115	99	123	130	161	156	193	187	231		20	106	123	139	161	139	172	183	226	219	270	262	324		25	139	161	183	211	183	226	240	296	287	355	344	425		30	175	202	230	266	230	284	301	372	361	446	433	534		35	213	247	281	324	280	347	367	454	441	544	528	652		40	254	294	335	386	334	413	438	541	526	649	630	777		10	54	63	68	79	71	89	90	113	106	132	125	155		15	85	99	107	125	113	142	143	178	168	209	197	246		20	119	139	151	176	159	199	200	250	235	294	277	345		25	156	182	198	230	208	261	263	328	309	385	364	453		30	196	229	248	290	262	328	331	413	388	484	457	569		35	239	280	303	353	320	400	403	504	474	591	557	695		40	286	333	361	421	381	477	481	601	565	705	665	828		10	43	50	57	66	58	72	75	94	90	112	108	135		15	69	80	90	105	91	114	119	149	143	178	171	213		20	96	112	127	147	128	159	168	209	201	250	240	299		25	127	147	166	193	168	209	220	274	264	328	316	392		30	159	185	209	243	211	263	276	344	331	412	397	493		35	194	226	255	296	257	321	337	420	404	503	484	602		40	231	269	304	353	307	383	402	501	482	600	577	717																																																																																				
	10	54	63	70	81	71	89	92	114	109	135	129	160		15	86	99	111	128	113	140	145	180	173	214	205	253		20	120	139	155	180	159	197	204	253	242	300	288	356		25	158	183	204	236	208	258	268	332	318	393	378	467		30	199	230	256	297	262	325	337	417	400	494	475	587		35	242	281	313	362	319	396	411	509	487	603	579	716		40	289	335	373	431	381	472	490	606	581	719	690	853		10	48	55	63	72	63	77	82	102	99	122	118	146		15	76	87	99	115	99	123	130	161	156	193	187	231		20	106	123	139	161	139	172	183	226	219	270	262	324		25	139	161	183	211	183	226	240	296	287	355	344	425		30	175	202	230	266	230	284	301	372	361	446	433	534		35	213	247	281	324	280	347	367	454	441	544	528	652		40	254	294	335	386	334	413	438	541	526	649	630	777		10	54	63	68	79	71	89	90	113	106	132	125	155		15	85	99	107	125	113	142	143	178	168	209	197	246		20	119	139	151	176	159	199	200	250	235	294	277	345		25	156	182	198	230	208	261	263	328	309	385	364	453		30	196	229	248	290	262	328	331	413	388	484	457	569		35	239	280	303	353	320	400	403	504	474	591	557	695		40	286	333	361	421	381	477	481	601	565	705	665	828		10	43	50	57	66	58	72	75	94	90	112	108	135		15	69	80	90	105	91	114	119	149	143	178	171	213		20	96	112	127	147	128	159	168	209	201	250	240	299		25	127	147	166	193	168	209	220	274	264	328	316	392		30	159	185	209	243	211	263	276	344	331	412	397	493		35	194	226	255	296	257	321	337	420	404	503	484	602		40	231	269	304	353	307	383	402	501	482	600	577	717																																																																																																		
	15	86	99	111	128	113	140	145	180	173	214	205	253		20	120	139	155	180	159	197	204	253	242	300	288	356		25	158	183	204	236	208	258	268	332	318	393	378	467		30	199	230	256	297	262	325	337	417	400	494	475	587		35	242	281	313	362	319	396	411	509	487	603	579	716		40	289	335	373	431	381	472	490	606	581	719	690	853		10	48	55	63	72	63	77	82	102	99	122	118	146		15	76	87	99	115	99	123	130	161	156	193	187	231		20	106	123	139	161	139	172	183	226	219	270	262	324		25	139	161	183	211	183	226	240	296	287	355	344	425		30	175	202	230	266	230	284	301	372	361	446	433	534		35	213	247	281	324	280	347	367	454	441	544	528	652		40	254	294	335	386	334	413	438	541	526	649	630	777		10	54	63	68	79	71	89	90	113	106	132	125	155		15	85	99	107	125	113	142	143	178	168	209	197	246		20	119	139	151	176	159	199	200	250	235	294	277	345		25	156	182	198	230	208	261	263	328	309	385	364	453		30	196	229	248	290	262	328	331	413	388	484	457	569		35	239	280	303	353	320	400	403	504	474	591	557	695		40	286	333	361	421	381	477	481	601	565	705	665	828		10	43	50	57	66	58	72	75	94	90	112	108	135		15	69	80	90	105	91	114	119	149	143	178	171	213		20	96	112	127	147	128	159	168	209	201	250	240	299		25	127	147	166	193	168	209	220	274	264	328	316	392		30	159	185	209	243	211	263	276	344	331	412	397	493		35	194	226	255	296	257	321	337	420	404	503	484	602		40	231	269	304	353	307	383	402	501	482	600	577	717																																																																																																																
	20	120	139	155	180	159	197	204	253	242	300	288	356		25	158	183	204	236	208	258	268	332	318	393	378	467		30	199	230	256	297	262	325	337	417	400	494	475	587		35	242	281	313	362	319	396	411	509	487	603	579	716		40	289	335	373	431	381	472	490	606	581	719	690	853		10	48	55	63	72	63	77	82	102	99	122	118	146		15	76	87	99	115	99	123	130	161	156	193	187	231		20	106	123	139	161	139	172	183	226	219	270	262	324		25	139	161	183	211	183	226	240	296	287	355	344	425		30	175	202	230	266	230	284	301	372	361	446	433	534		35	213	247	281	324	280	347	367	454	441	544	528	652		40	254	294	335	386	334	413	438	541	526	649	630	777		10	54	63	68	79	71	89	90	113	106	132	125	155		15	85	99	107	125	113	142	143	178	168	209	197	246		20	119	139	151	176	159	199	200	250	235	294	277	345		25	156	182	198	230	208	261	263	328	309	385	364	453		30	196	229	248	290	262	328	331	413	388	484	457	569		35	239	280	303	353	320	400	403	504	474	591	557	695		40	286	333	361	421	381	477	481	601	565	705	665	828		10	43	50	57	66	58	72	75	94	90	112	108	135		15	69	80	90	105	91	114	119	149	143	178	171	213		20	96	112	127	147	128	159	168	209	201	250	240	299		25	127	147	166	193	168	209	220	274	264	328	316	392		30	159	185	209	243	211	263	276	344	331	412	397	493		35	194	226	255	296	257	321	337	420	404	503	484	602		40	231	269	304	353	307	383	402	501	482	600	577	717																																																																																																																														
	25	158	183	204	236	208	258	268	332	318	393	378	467		30	199	230	256	297	262	325	337	417	400	494	475	587		35	242	281	313	362	319	396	411	509	487	603	579	716		40	289	335	373	431	381	472	490	606	581	719	690	853		10	48	55	63	72	63	77	82	102	99	122	118	146		15	76	87	99	115	99	123	130	161	156	193	187	231		20	106	123	139	161	139	172	183	226	219	270	262	324		25	139	161	183	211	183	226	240	296	287	355	344	425		30	175	202	230	266	230	284	301	372	361	446	433	534		35	213	247	281	324	280	347	367	454	441	544	528	652		40	254	294	335	386	334	413	438	541	526	649	630	777		10	54	63	68	79	71	89	90	113	106	132	125	155		15	85	99	107	125	113	142	143	178	168	209	197	246		20	119	139	151	176	159	199	200	250	235	294	277	345		25	156	182	198	230	208	261	263	328	309	385	364	453		30	196	229	248	290	262	328	331	413	388	484	457	569		35	239	280	303	353	320	400	403	504	474	591	557	695		40	286	333	361	421	381	477	481	601	565	705	665	828		10	43	50	57	66	58	72	75	94	90	112	108	135		15	69	80	90	105	91	114	119	149	143	178	171	213		20	96	112	127	147	128	159	168	209	201	250	240	299		25	127	147	166	193	168	209	220	274	264	328	316	392		30	159	185	209	243	211	263	276	344	331	412	397	493		35	194	226	255	296	257	321	337	420	404	503	484	602		40	231	269	304	353	307	383	402	501	482	600	577	717																																																																																																																																												
	30	199	230	256	297	262	325	337	417	400	494	475	587		35	242	281	313	362	319	396	411	509	487	603	579	716		40	289	335	373	431	381	472	490	606	581	719	690	853		10	48	55	63	72	63	77	82	102	99	122	118	146		15	76	87	99	115	99	123	130	161	156	193	187	231		20	106	123	139	161	139	172	183	226	219	270	262	324		25	139	161	183	211	183	226	240	296	287	355	344	425		30	175	202	230	266	230	284	301	372	361	446	433	534		35	213	247	281	324	280	347	367	454	441	544	528	652		40	254	294	335	386	334	413	438	541	526	649	630	777		10	54	63	68	79	71	89	90	113	106	132	125	155		15	85	99	107	125	113	142	143	178	168	209	197	246		20	119	139	151	176	159	199	200	250	235	294	277	345		25	156	182	198	230	208	261	263	328	309	385	364	453		30	196	229	248	290	262	328	331	413	388	484	457	569		35	239	280	303	353	320	400	403	504	474	591	557	695		40	286	333	361	421	381	477	481	601	565	705	665	828		10	43	50	57	66	58	72	75	94	90	112	108	135		15	69	80	90	105	91	114	119	149	143	178	171	213		20	96	112	127	147	128	159	168	209	201	250	240	299		25	127	147	166	193	168	209	220	274	264	328	316	392		30	159	185	209	243	211	263	276	344	331	412	397	493		35	194	226	255	296	257	321	337	420	404	503	484	602		40	231	269	304	353	307	383	402	501	482	600	577	717																																																																																																																																																										
	35	242	281	313	362	319	396	411	509	487	603	579	716		40	289	335	373	431	381	472	490	606	581	719	690	853		10	48	55	63	72	63	77	82	102	99	122	118	146		15	76	87	99	115	99	123	130	161	156	193	187	231		20	106	123	139	161	139	172	183	226	219	270	262	324		25	139	161	183	211	183	226	240	296	287	355	344	425		30	175	202	230	266	230	284	301	372	361	446	433	534		35	213	247	281	324	280	347	367	454	441	544	528	652		40	254	294	335	386	334	413	438	541	526	649	630	777		10	54	63	68	79	71	89	90	113	106	132	125	155		15	85	99	107	125	113	142	143	178	168	209	197	246		20	119	139	151	176	159	199	200	250	235	294	277	345		25	156	182	198	230	208	261	263	328	309	385	364	453		30	196	229	248	290	262	328	331	413	388	484	457	569		35	239	280	303	353	320	400	403	504	474	591	557	695		40	286	333	361	421	381	477	481	601	565	705	665	828		10	43	50	57	66	58	72	75	94	90	112	108	135		15	69	80	90	105	91	114	119	149	143	178	171	213		20	96	112	127	147	128	159	168	209	201	250	240	299		25	127	147	166	193	168	209	220	274	264	328	316	392		30	159	185	209	243	211	263	276	344	331	412	397	493		35	194	226	255	296	257	321	337	420	404	503	484	602		40	231	269	304	353	307	383	402	501	482	600	577	717																																																																																																																																																																								
	40	289	335	373	431	381	472	490	606	581	719	690	853		10	48	55	63	72	63	77	82	102	99	122	118	146		15	76	87	99	115	99	123	130	161	156	193	187	231		20	106	123	139	161	139	172	183	226	219	270	262	324		25	139	161	183	211	183	226	240	296	287	355	344	425		30	175	202	230	266	230	284	301	372	361	446	433	534		35	213	247	281	324	280	347	367	454	441	544	528	652		40	254	294	335	386	334	413	438	541	526	649	630	777		10	54	63	68	79	71	89	90	113	106	132	125	155		15	85	99	107	125	113	142	143	178	168	209	197	246		20	119	139	151	176	159	199	200	250	235	294	277	345		25	156	182	198	230	208	261	263	328	309	385	364	453		30	196	229	248	290	262	328	331	413	388	484	457	569		35	239	280	303	353	320	400	403	504	474	591	557	695		40	286	333	361	421	381	477	481	601	565	705	665	828		10	43	50	57	66	58	72	75	94	90	112	108	135		15	69	80	90	105	91	114	119	149	143	178	171	213		20	96	112	127	147	128	159	168	209	201	250	240	299		25	127	147	166	193	168	209	220	274	264	328	316	392		30	159	185	209	243	211	263	276	344	331	412	397	493		35	194	226	255	296	257	321	337	420	404	503	484	602		40	231	269	304	353	307	383	402	501	482	600	577	717																																																																																																																																																																																						
	10	48	55	63	72	63	77	82	102	99	122	118	146		15	76	87	99	115	99	123	130	161	156	193	187	231		20	106	123	139	161	139	172	183	226	219	270	262	324		25	139	161	183	211	183	226	240	296	287	355	344	425		30	175	202	230	266	230	284	301	372	361	446	433	534		35	213	247	281	324	280	347	367	454	441	544	528	652		40	254	294	335	386	334	413	438	541	526	649	630	777		10	54	63	68	79	71	89	90	113	106	132	125	155		15	85	99	107	125	113	142	143	178	168	209	197	246		20	119	139	151	176	159	199	200	250	235	294	277	345		25	156	182	198	230	208	261	263	328	309	385	364	453		30	196	229	248	290	262	328	331	413	388	484	457	569		35	239	280	303	353	320	400	403	504	474	591	557	695		40	286	333	361	421	381	477	481	601	565	705	665	828		10	43	50	57	66	58	72	75	94	90	112	108	135		15	69	80	90	105	91	114	119	149	143	178	171	213		20	96	112	127	147	128	159	168	209	201	250	240	299		25	127	147	166	193	168	209	220	274	264	328	316	392		30	159	185	209	243	211	263	276	344	331	412	397	493		35	194	226	255	296	257	321	337	420	404	503	484	602		40	231	269	304	353	307	383	402	501	482	600	577	717																																																																																																																																																																																																				
	15	76	87	99	115	99	123	130	161	156	193	187	231		20	106	123	139	161	139	172	183	226	219	270	262	324		25	139	161	183	211	183	226	240	296	287	355	344	425		30	175	202	230	266	230	284	301	372	361	446	433	534		35	213	247	281	324	280	347	367	454	441	544	528	652		40	254	294	335	386	334	413	438	541	526	649	630	777		10	54	63	68	79	71	89	90	113	106	132	125	155		15	85	99	107	125	113	142	143	178	168	209	197	246		20	119	139	151	176	159	199	200	250	235	294	277	345		25	156	182	198	230	208	261	263	328	309	385	364	453		30	196	229	248	290	262	328	331	413	388	484	457	569		35	239	280	303	353	320	400	403	504	474	591	557	695		40	286	333	361	421	381	477	481	601	565	705	665	828		10	43	50	57	66	58	72	75	94	90	112	108	135		15	69	80	90	105	91	114	119	149	143	178	171	213		20	96	112	127	147	128	159	168	209	201	250	240	299		25	127	147	166	193	168	209	220	274	264	328	316	392		30	159	185	209	243	211	263	276	344	331	412	397	493		35	194	226	255	296	257	321	337	420	404	503	484	602		40	231	269	304	353	307	383	402	501	482	600	577	717																																																																																																																																																																																																																		
	20	106	123	139	161	139	172	183	226	219	270	262	324		25	139	161	183	211	183	226	240	296	287	355	344	425		30	175	202	230	266	230	284	301	372	361	446	433	534		35	213	247	281	324	280	347	367	454	441	544	528	652		40	254	294	335	386	334	413	438	541	526	649	630	777		10	54	63	68	79	71	89	90	113	106	132	125	155		15	85	99	107	125	113	142	143	178	168	209	197	246		20	119	139	151	176	159	199	200	250	235	294	277	345		25	156	182	198	230	208	261	263	328	309	385	364	453		30	196	229	248	290	262	328	331	413	388	484	457	569		35	239	280	303	353	320	400	403	504	474	591	557	695		40	286	333	361	421	381	477	481	601	565	705	665	828		10	43	50	57	66	58	72	75	94	90	112	108	135		15	69	80	90	105	91	114	119	149	143	178	171	213		20	96	112	127	147	128	159	168	209	201	250	240	299		25	127	147	166	193	168	209	220	274	264	328	316	392		30	159	185	209	243	211	263	276	344	331	412	397	493		35	194	226	255	296	257	321	337	420	404	503	484	602		40	231	269	304	353	307	383	402	501	482	600	577	717																																																																																																																																																																																																																																
	25	139	161	183	211	183	226	240	296	287	355	344	425		30	175	202	230	266	230	284	301	372	361	446	433	534		35	213	247	281	324	280	347	367	454	441	544	528	652		40	254	294	335	386	334	413	438	541	526	649	630	777		10	54	63	68	79	71	89	90	113	106	132	125	155		15	85	99	107	125	113	142	143	178	168	209	197	246		20	119	139	151	176	159	199	200	250	235	294	277	345		25	156	182	198	230	208	261	263	328	309	385	364	453		30	196	229	248	290	262	328	331	413	388	484	457	569		35	239	280	303	353	320	400	403	504	474	591	557	695		40	286	333	361	421	381	477	481	601	565	705	665	828		10	43	50	57	66	58	72	75	94	90	112	108	135		15	69	80	90	105	91	114	119	149	143	178	171	213		20	96	112	127	147	128	159	168	209	201	250	240	299		25	127	147	166	193	168	209	220	274	264	328	316	392		30	159	185	209	243	211	263	276	344	331	412	397	493		35	194	226	255	296	257	321	337	420	404	503	484	602		40	231	269	304	353	307	383	402	501	482	600	577	717																																																																																																																																																																																																																																														
	30	175	202	230	266	230	284	301	372	361	446	433	534		35	213	247	281	324	280	347	367	454	441	544	528	652		40	254	294	335	386	334	413	438	541	526	649	630	777		10	54	63	68	79	71	89	90	113	106	132	125	155		15	85	99	107	125	113	142	143	178	168	209	197	246		20	119	139	151	176	159	199	200	250	235	294	277	345		25	156	182	198	230	208	261	263	328	309	385	364	453		30	196	229	248	290	262	328	331	413	388	484	457	569		35	239	280	303	353	320	400	403	504	474	591	557	695		40	286	333	361	421	381	477	481	601	565	705	665	828		10	43	50	57	66	58	72	75	94	90	112	108	135		15	69	80	90	105	91	114	119	149	143	178	171	213		20	96	112	127	147	128	159	168	209	201	250	240	299		25	127	147	166	193	168	209	220	274	264	328	316	392		30	159	185	209	243	211	263	276	344	331	412	397	493		35	194	226	255	296	257	321	337	420	404	503	484	602		40	231	269	304	353	307	383	402	501	482	600	577	717																																																																																																																																																																																																																																																												
	35	213	247	281	324	280	347	367	454	441	544	528	652		40	254	294	335	386	334	413	438	541	526	649	630	777		10	54	63	68	79	71	89	90	113	106	132	125	155		15	85	99	107	125	113	142	143	178	168	209	197	246		20	119	139	151	176	159	199	200	250	235	294	277	345		25	156	182	198	230	208	261	263	328	309	385	364	453		30	196	229	248	290	262	328	331	413	388	484	457	569		35	239	280	303	353	320	400	403	504	474	591	557	695		40	286	333	361	421	381	477	481	601	565	705	665	828		10	43	50	57	66	58	72	75	94	90	112	108	135		15	69	80	90	105	91	114	119	149	143	178	171	213		20	96	112	127	147	128	159	168	209	201	250	240	299		25	127	147	166	193	168	209	220	274	264	328	316	392		30	159	185	209	243	211	263	276	344	331	412	397	493		35	194	226	255	296	257	321	337	420	404	503	484	602		40	231	269	304	353	307	383	402	501	482	600	577	717																																																																																																																																																																																																																																																																										
	40	254	294	335	386	334	413	438	541	526	649	630	777		10	54	63	68	79	71	89	90	113	106	132	125	155		15	85	99	107	125	113	142	143	178	168	209	197	246		20	119	139	151	176	159	199	200	250	235	294	277	345		25	156	182	198	230	208	261	263	328	309	385	364	453		30	196	229	248	290	262	328	331	413	388	484	457	569		35	239	280	303	353	320	400	403	504	474	591	557	695		40	286	333	361	421	381	477	481	601	565	705	665	828		10	43	50	57	66	58	72	75	94	90	112	108	135		15	69	80	90	105	91	114	119	149	143	178	171	213		20	96	112	127	147	128	159	168	209	201	250	240	299		25	127	147	166	193	168	209	220	274	264	328	316	392		30	159	185	209	243	211	263	276	344	331	412	397	493		35	194	226	255	296	257	321	337	420	404	503	484	602		40	231	269	304	353	307	383	402	501	482	600	577	717																																																																																																																																																																																																																																																																																								
	10	54	63	68	79	71	89	90	113	106	132	125	155		15	85	99	107	125	113	142	143	178	168	209	197	246		20	119	139	151	176	159	199	200	250	235	294	277	345		25	156	182	198	230	208	261	263	328	309	385	364	453		30	196	229	248	290	262	328	331	413	388	484	457	569		35	239	280	303	353	320	400	403	504	474	591	557	695		40	286	333	361	421	381	477	481	601	565	705	665	828		10	43	50	57	66	58	72	75	94	90	112	108	135		15	69	80	90	105	91	114	119	149	143	178	171	213		20	96	112	127	147	128	159	168	209	201	250	240	299		25	127	147	166	193	168	209	220	274	264	328	316	392		30	159	185	209	243	211	263	276	344	331	412	397	493		35	194	226	255	296	257	321	337	420	404	503	484	602		40	231	269	304	353	307	383	402	501	482	600	577	717																																																																																																																																																																																																																																																																																																						
	15	85	99	107	125	113	142	143	178	168	209	197	246		20	119	139	151	176	159	199	200	250	235	294	277	345		25	156	182	198	230	208	261	263	328	309	385	364	453		30	196	229	248	290	262	328	331	413	388	484	457	569		35	239	280	303	353	320	400	403	504	474	591	557	695		40	286	333	361	421	381	477	481	601	565	705	665	828		10	43	50	57	66	58	72	75	94	90	112	108	135		15	69	80	90	105	91	114	119	149	143	178	171	213		20	96	112	127	147	128	159	168	209	201	250	240	299		25	127	147	166	193	168	209	220	274	264	328	316	392		30	159	185	209	243	211	263	276	344	331	412	397	493		35	194	226	255	296	257	321	337	420	404	503	484	602		40	231	269	304	353	307	383	402	501	482	600	577	717																																																																																																																																																																																																																																																																																																																				
	20	119	139	151	176	159	199	200	250	235	294	277	345		25	156	182	198	230	208	261	263	328	309	385	364	453		30	196	229	248	290	262	328	331	413	388	484	457	569		35	239	280	303	353	320	400	403	504	474	591	557	695		40	286	333	361	421	381	477	481	601	565	705	665	828		10	43	50	57	66	58	72	75	94	90	112	108	135		15	69	80	90	105	91	114	119	149	143	178	171	213		20	96	112	127	147	128	159	168	209	201	250	240	299		25	127	147	166	193	168	209	220	274	264	328	316	392		30	159	185	209	243	211	263	276	344	331	412	397	493		35	194	226	255	296	257	321	337	420	404	503	484	602		40	231	269	304	353	307	383	402	501	482	600	577	717																																																																																																																																																																																																																																																																																																																																		
	25	156	182	198	230	208	261	263	328	309	385	364	453		30	196	229	248	290	262	328	331	413	388	484	457	569		35	239	280	303	353	320	400	403	504	474	591	557	695		40	286	333	361	421	381	477	481	601	565	705	665	828		10	43	50	57	66	58	72	75	94	90	112	108	135		15	69	80	90	105	91	114	119	149	143	178	171	213		20	96	112	127	147	128	159	168	209	201	250	240	299		25	127	147	166	193	168	209	220	274	264	328	316	392		30	159	185	209	243	211	263	276	344	331	412	397	493		35	194	226	255	296	257	321	337	420	404	503	484	602		40	231	269	304	353	307	383	402	501	482	600	577	717																																																																																																																																																																																																																																																																																																																																																
	30	196	229	248	290	262	328	331	413	388	484	457	569		35	239	280	303	353	320	400	403	504	474	591	557	695		40	286	333	361	421	381	477	481	601	565	705	665	828		10	43	50	57	66	58	72	75	94	90	112	108	135		15	69	80	90	105	91	114	119	149	143	178	171	213		20	96	112	127	147	128	159	168	209	201	250	240	299		25	127	147	166	193	168	209	220	274	264	328	316	392		30	159	185	209	243	211	263	276	344	331	412	397	493		35	194	226	255	296	257	321	337	420	404	503	484	602		40	231	269	304	353	307	383	402	501	482	600	577	717																																																																																																																																																																																																																																																																																																																																																														
	35	239	280	303	353	320	400	403	504	474	591	557	695		40	286	333	361	421	381	477	481	601	565	705	665	828		10	43	50	57	66	58	72	75	94	90	112	108	135		15	69	80	90	105	91	114	119	149	143	178	171	213		20	96	112	127	147	128	159	168	209	201	250	240	299		25	127	147	166	193	168	209	220	274	264	328	316	392		30	159	185	209	243	211	263	276	344	331	412	397	493		35	194	226	255	296	257	321	337	420	404	503	484	602		40	231	269	304	353	307	383	402	501	482	600	577	717																																																																																																																																																																																																																																																																																																																																																																												
	40	286	333	361	421	381	477	481	601	565	705	665	828		10	43	50	57	66	58	72	75	94	90	112	108	135		15	69	80	90	105	91	114	119	149	143	178	171	213		20	96	112	127	147	128	159	168	209	201	250	240	299		25	127	147	166	193	168	209	220	274	264	328	316	392		30	159	185	209	243	211	263	276	344	331	412	397	493		35	194	226	255	296	257	321	337	420	404	503	484	602		40	231	269	304	353	307	383	402	501	482	600	577	717																																																																																																																																																																																																																																																																																																																																																																																										
	10	43	50	57	66	58	72	75	94	90	112	108	135		15	69	80	90	105	91	114	119	149	143	178	171	213		20	96	112	127	147	128	159	168	209	201	250	240	299		25	127	147	166	193	168	209	220	274	264	328	316	392		30	159	185	209	243	211	263	276	344	331	412	397	493		35	194	226	255	296	257	321	337	420	404	503	484	602		40	231	269	304	353	307	383	402	501	482	600	577	717																																																																																																																																																																																																																																																																																																																																																																																																								
	15	69	80	90	105	91	114	119	149	143	178	171	213		20	96	112	127	147	128	159	168	209	201	250	240	299		25	127	147	166	193	168	209	220	274	264	328	316	392		30	159	185	209	243	211	263	276	344	331	412	397	493		35	194	226	255	296	257	321	337	420	404	503	484	602		40	231	269	304	353	307	383	402	501	482	600	577	717																																																																																																																																																																																																																																																																																																																																																																																																																						
	20	96	112	127	147	128	159	168	209	201	250	240	299		25	127	147	166	193	168	209	220	274	264	328	316	392		30	159	185	209	243	211	263	276	344	331	412	397	493		35	194	226	255	296	257	321	337	420	404	503	484	602		40	231	269	304	353	307	383	402	501	482	600	577	717																																																																																																																																																																																																																																																																																																																																																																																																																																				
	25	127	147	166	193	168	209	220	274	264	328	316	392		30	159	185	209	243	211	263	276	344	331	412	397	493		35	194	226	255	296	257	321	337	420	404	503	484	602		40	231	269	304	353	307	383	402	501	482	600	577	717																																																																																																																																																																																																																																																																																																																																																																																																																																																		
	30	159	185	209	243	211	263	276	344	331	412	397	493		35	194	226	255	296	257	321	337	420	404	503	484	602		40	231	269	304	353	307	383	402	501	482	600	577	717																																																																																																																																																																																																																																																																																																																																																																																																																																																																
	35	194	226	255	296	257	321	337	420	404	503	484	602		40	231	269	304	353	307	383	402	501	482	600	577	717																																																																																																																																																																																																																																																																																																																																																																																																																																																																														
	40	231	269	304	353	307	383	402	501	482	600	577	717																																																																																																																																																																																																																																																																																																																																																																																																																																																																																												





(1) See more details p. 44

XL³ 800 metal cabinets and enclosures

Cat.Nos		IP 43 (with door and seal)											
		without cable sleeve								with cable sleeve			
		204 01	204 02	204 06	204 07	204 03	204 04	204 08	204 09	204 03 + 204 23	204 04 + 204 24	204 08 + 204 23	204 09 + 204 24
Installation requirements ⁽¹⁾	Δt avg. (K)	Dissipated power (W)											
	10	53	62	67	78	70	87	89	110	104	129	123	152
	15	84	97	107	124	111	138	140	174	165	205	195	241
	20	118	137	150	173	156	194	197	245	232	287	273	338
	25	155	180	196	228	205	254	259	321	304	377	359	444
	30	194	226	247	286	257	320	325	404	383	474	451	558
	35	237	275	301	349	314	390	397	492	467	578	550	681
	40	283	328	359	416	374	465	473	587	557	690	656	812
	10	49	57	64	74	65	80	83	103	99	123	118	145
	15	78	90	101	116	103	127	132	164	157	194	186	230
	20	109	127	141	163	144	179	185	230	220	272	262	323
	25	144	166	185	214	189	235	243	302	289	358	343	424
	30	181	209	233	270	238	295	306	379	363	450	432	533
	35	220	255	284	329	290	360	373	462	443	548	526	651
	40	263	304	339	392	346	429	445	551	529	654	628	776
	10	45	53	60	69	60	74	78	97	94	116	112	139
	15	72	83	95	109	94	117	124	153	149	183	178	220
	20	101	117	133	153	132	164	174	215	209	258	250	308
	25	133	153	174	201	174	215	228	282	274	338	328	405
	30	167	193	219	253	219	271	287	354	344	425	412	509
	35	203	235	267	309	267	330	350	432	420	518	503	621
	40	242	280	319	368	318	394	417	516	500	618	600	740
	10	51	60	65	75	68	85	86	107	101	126	119	148
	15	81	94	102	119	108	135	136	170	160	199	188	234
	20	113	132	143	167	151	189	191	238	224	280	264	329
	25	149	174	188	219	199	248	251	313	294	367	346	431
	30	187	218	237	276	250	312	315	393	370	461	435	542
	35	228	266	289	336	304	381	384	480	451	563	531	662
	40	272	317	344	401	363	454	458	572	538	671	633	789
	10	43	50	57	66	58	72	75	94	90	112	108	135
	15	69	80	90	105	91	114	119	149	143	178	171	213
	20	96	112	127	147	128	159	168	209	201	250	240	299
	25	127	147	166	193	168	209	220	274	264	328	316	392
	30	159	185	209	243	211	263	276	344	331	412	397	493
	35	194	226	255	296	257	321	337	420	404	503	484	602
	40	231	269	304	353	307	383	402	501	482	600	577	717

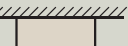
(1) See more details p. 44

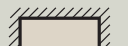
Annexes (continued)

XL ³ 800 IP 55 metal cabinets and enclosures													
		IP 55 (with door)											
		without cable sleeve								with cable sleeve			
Cat.Nos		204 51	204 52	204 56	204 57	204 53	204 54	204 58	204 59	204 53 + 204 73	204 54 + 204 74	204 58 + 204 73	204 59 + 204 74
Installation requirements ⁽¹⁾	Δt avg. (K)	Dissipated power (W)											
			10	57	66	72	82	74	115	74	115	112	162
	15	90	104	113	131	118	183	118	183	178	256	178	256
	20	126	146	159	183	165	256	165	256	250	360	250	360
	25	166	191	209	241	217	336	217	336	328	472	328	472
	30	208	241	262	302	273	423	273	423	412	594	412	594
	35	254	293	320	369	333	516	333	516	503	724	503	724
	40	303	350	382	440	397	615	397	615	600	864	600	864
	10	53	61	68	78	69	109	69	109	107	155	107	155
	15	84	97	107	123	109	172	109	172	170	246	170	246
	20	118	136	150	173	154	241	154	241	238	345	238	345
	25	154	178	197	227	202	317	202	317	313	453	313	453
	30	194	224	248	286	254	398	254	398	393	569	393	569
	35	237	273	303	348	309	486	309	486	479	694	479	694
	40	282	325	361	415	369	579	369	579	572	828	572	828
	10	49	56	64	73	64	102	64	102	102	149	102	149
	15	78	89	101	116	101	161	101	161	161	235	161	235
	20	109	125	142	163	142	227	142	227	226	330	226	330
	25	143	165	186	214	186	297	186	297	297	433	297	433
	30	180	207	234	269	234	374	234	374	374	545	374	545
	35	219	252	285	328	286	456	286	456	456	664	456	664
	40	262	301	340	391	340	544	340	544	543	792	543	792
	10	55	63	69	80	72	112	72	112	109	158	109	158
	15	87	101	109	126	114	178	114	178	172	249	172	249
	20	121	141	153	177	161	250	161	250	242	350	242	350
	25	159	185	200	232	211	328	211	328	317	459	317	459
	30	200	233	252	292	265	412	265	412	399	578	399	578
	35	244	284	307	356	323	503	323	503	487	705	487	705
	40	292	339	366	425	386	600	386	600	580	840	580	840
	10	47	54	61	70	62	99	62	99	98	144	98	144
	15	74	86	96	112	98	157	98	157	156	228	156	228
	20	104	121	135	157	137	220	137	220	218	320	218	320
	25	137	158	178	205	180	289	180	289	286	420	286	420
	30	172	199	223	258	226	363	226	363	360	528	360	528
	35	210	243	272	315	276	443	276	443	439	644	439	644
	40	250	290	325	376	329	528	329	528	524	769	524	769

(1) See more details p. 44

XL³ 4000 enclosures (h: 2000 mm)

Dimensions (mm)		IP 30 (without door)						IP 55 (with door)					
		Height	2000			2000							
			Width	725	975	725	975	725	975	725	975		
Depth	475	725	975	475	725	975	475	725	975	475	725	975	
Installation requirements ⁽¹⁾	Δt avg. (K)	Dissipated power (W)											
	10	203	252	301	248	301	353	189	238	287	230	282	335
	15	320	471	474	391	474	557	298	375	452	362	445	527
	20	447	554	662	546	662	778	416	524	631	505	621	737
	25	584	724	865	714	865	1016	544	685	825	660	812	963
	30	731	907	1083	893	1083	1272	681	857	1033	827	1016	1206
	35	888	1102	1316	1086	1316	1546	828	1042	1256	1005	1235	1465
	40	1056	1310	1564	1291	1564	1838	984	1238	1493	1194	1468	1742
	10	169	218	266	202	255	307	155	204	253	183	236	289
	15	266	343	420	318	401	484	244	321	398	289	372	455
	20	371	479	586	444	560	676	341	448	556	403	519	635
	25	485	625	766	580	732	883	445	586	726	527	678	830
	30	607	783	959	727	916	1106	557	733	909	660	850	1039
	35	738	952	1165	883	1113	1344	677	891	1105	802	1032	1263
	40	877	1131	1385	1050	1323	1597	805	1059	1314	953	1227	1501
	10	146	183	220	179	220	261	172	181	190	201	210	220
	15	230	288	347	282	347	411	271	285	299	316	331	346
	20	321	403	484	394	484	574	379	398	418	442	463	484
	25	420	526	633	516	633	750	495	521	546	577	604	632
	30	526	659	792	646	792	939	620	652	684	722	757	791
	35	639	801	963	784	963	1141	753	792	832	878	920	962
	40	760	952	1144	932	1144	1356	895	942	988	1044	1093	1143
	10	124	149	174	157	186	215	110	135	160	138	167	196
	15	195	234	274	247	292	338	173	212	252	218	263	309
	20	272	327	382	345	408	472	241	297	352	304	368	431
	25	355	427	500	451	534	617	315	388	460	397	480	563
	30	445	535	626	564	668	772	395	485	576	498	602	706
	35	540	650	760	686	812	938	480	590	700	605	731	857
	40	642	773	904	815	965	1115	571	701	832	719	869	1019
	10	160	204	249	259	237	283	146	191	235	172	218	265
	15	252	322	392	408	373	446	230	300	370	271	344	417
	20	352	450	547	570	521	623	322	419	517	378	480	583
	25	460	588	715	745	681	815	420	548	675	494	628	761
	30	576	736	895	933	853	1020	526	686	846	618	786	953
	35	700	894	1088	1134	1036	1240	640	834	1028	752	955	1159
	40	832	1063	1293	1348	1232	1473	760	991	1222	893	1135	1377
	10	115	135	156	145	168	191	101	122	142	127	149	172
	15	181	213	246	229	265	300	159	192	224	199	235	271
	20	253	298	343	319	369	420	222	268	313	279	329	379
	25	330	390	449	417	483	548	291	350	409	364	430	495
	30	414	488	562	523	605	687	364	438	512	456	538	620
	35	503	593	683	635	735	834	442	532	623	554	654	753
	40	597	705	812	755	873	992	526	633	740	659	777	895

(1) See more details p. 44

Annexes (continued)

XL ³ 4000 enclosures (h: 2200 mm)													
		IP 30 (without door)						IP 55 (with door)					
Dimensions (mm)	Height	2200						2200					
	Width	725			975			725			975		
	Depth	475	725	975	475	725	975	475	725	975	475	725	975
Installation requirements ⁽¹⁾	Δt avg. (K)	Dissipated power (W)											
	10	222	275	328	271	328	385	207	260	313	251	308	364
	15	350	508	517	427	517	606	326	409	493	395	484	574
	20	489	605	722	597	722	846	455	572	688	552	677	801
	25	639	791	943	780	943	1106	595	747	899	721	884	1047
	30	800	990	1181	977	1181	1385	745	936	1126	903	1107	1311
	35	972	1204	1435	1187	1435	1683	906	1137	1368	1098	1345	1593
	10	184	237	290	220	277	333	169	222	275	200	256	313
	15	290	373	457	347	436	525	266	349	433	315	404	493
	20	405	522	638	484	609	734	372	488	604	439	564	689
	25	530	682	834	633	796	959	486	638	790	574	737	900
	30	663	853	1044	793	997	1200	608	799	989	719	923	1127
	35	806	1037	1269	963	1211	1459	739	971	1202	874	1122	1369
	10	159	199	239	195	239	282	188	198	208	219	229	240
	15	251	313	376	308	376	445	296	312	327	345	361	377
	20	350	438	525	430	525	621	414	435	457	482	504	527
	25	458	572	686	561	686	812	541	569	597	629	659	689
	30	573	716	860	703	860	1016	677	712	747	788	825	862
	35	697	871	1045	854	1045	1235	823	865	908	958	1003	1048
	10	134	161	188	170	201	231	119	146	172	150	180	211
	15	212	253	295	268	316	364	188	230	271	236	284	332
	20	296	354	413	375	442	508	262	321	379	330	396	463
	25	386	463	539	490	577	664	342	419	496	431	518	605
	30	484	579	675	613	723	832	429	525	620	539	649	758
	35	588	704	821	745	878	1011	521	638	754	656	788	921
	10	176	224	272	285	259	310	160	209	257	188	239	289
	15	277	353	429	448	408	488	253	329	405	296	376	456
	20	386	493	599	626	570	681	353	459	566	414	525	636
	25	505	644	783	819	745	890	461	600	739	541	686	831
	30	632	806	980	1025	933	1115	577	751	925	677	859	1041
	35	768	980	1191	1246	1134	1355	702	913	1125	823	1044	1265
	10	126	148	170	159	183	207	110	133	155	138	163	187
	15	198	233	268	250	288	327	174	209	244	218	256	294
	20	277	325	374	349	403	456	243	292	340	304	358	411
	25	361	425	488	456	526	596	318	381	445	398	467	537
	30	453	532	612	571	659	746	398	477	557	498	585	673
	35	550	647	743	695	801	907	483	580	677	605	711	817
	10	654	769	883	825	952	1078	575	689	804	719	845	972

(1) See more details p. 44

XL³ 4000 cable sleeves

Dimensions (mm)		IP 30 (without door)						IP 55 (with door)					
		2000			2200			2000			2200		
		Height	Width		Depth		Height	Width		Depth		Height	Width
Installation requirements ⁽¹⁾	Δt avg. (K)	Dissipated power (W)											
		475	725	975	475	725	975	475	725	975	475	725	975
	10	158	203	248	173	222	271	149	194	239	163	212	261
	15	249	320	391	273	350	427	235	306	377	257	334	412
	20	347	447	546	381	489	597	328	427	526	359	467	575
	25	454	584	714	498	639	780	428	558	688	469	610	752
	30	569	731	893	623	800	977	536	699	861	587	764	941
	35	691	888	1086	757	972	1187	651	849	1046	714	929	1144
	40	821	1056	1291	900	1156	1411	774	1009	1244	848	1104	1359
	10	135	181	226	148	197	246	126	171	217	138	187	236
	15	213	284	355	233	311	388	199	270	341	218	295	372
	20	298	397	496	326	434	542	278	377	477	304	412	520
	25	389	519	649	426	567	709	363	493	623	397	539	680
	30	487	650	812	534	710	887	455	617	780	498	674	851
	35	592	790	987	648	863	1078	553	750	948	605	820	1035
	40	704	939	1173	771	1026	1282	657	892	1126	719	974	1230
	10	113	146	179	123	159	195	144	152	160	157	166	176
	15	178	230	282	194	251	308	226	239	252	248	262	276
	20	248	321	394	271	350	430	316	334	353	346	366	386
	25	324	420	516	354	458	561	413	437	461	452	479	505
	30	406	526	646	444	573	703	517	547	577	567	599	632
	35	494	639	784	539	697	854	629	665	701	689	728	768
	40	587	760	932	641	828	1015	747	790	834	818	866	913
	10	90	112	133	98	121	144	81	103	124	88	111	134
	15	142	176	209	155	191	227	128	162	195	139	175	211
	20	199	246	293	216	267	317	179	226	273	194	245	295
	25	259	321	382	283	348	414	234	295	356	254	320	386
	30	325	402	479	354	436	519	292	369	446	318	400	483
	35	395	488	582	430	530	630	355	449	542	387	487	587
	40	469	580	692	511	630	749	422	534	645	459	578	697
	10	130	172	214	143	189	235	121	163	205	133	179	225
	15	204	271	337	225	297	370	190	257	323	209	282	354
	20	285	378	471	314	415	517	266	358	451	292	393	495
	25	373	494	615	410	543	675	347	468	589	381	514	647
	30	467	619	771	513	679	846	435	586	738	477	643	810
	35	568	752	936	624	826	1028	528	713	897	580	782	984
	40	675	894	1113	741	981	1221	628	847	1066	689	929	1169
	10	85	103	121	93	113	132	76	94	112	83	103	123
	15	133	162	191	146	177	209	119	148	177	130	162	193
	20	186	227	267	204	248	291	166	207	247	182	226	270
	25	243	296	349	266	324	381	217	270	323	238	295	352
	30	305	371	437	334	405	477	272	338	405	298	369	441
	35	370	451	531	405	493	580	331	411	492	362	449	536
	40	440	536	631	482	585	689	393	489	584	430	534	637

(1) See more details p. 44

Annexes (continued)

RECOMMENDED TIGHTENING TORQUE VALUES

Device		Tool	Torque
DX < 63 A	Cage terminals	6.5 mm or PZ 2 screwdriver	2.5 Nm
DX 80 à 125 A	Cage terminals	8 mm or PZ 3 screwdriver	3.5 Nm
Vistop 63/100/125/160 A	Cage terminals	4 mm hex key	6 Nm
DPX-IS 250	Connection plates or cage terminals	5 mm hex key	10 Nm
DPX-IS 630	Connection plates or cage terminals	8 mm hex key	24 Nm
DPX-IS 1600	Connection plates	10 mm hex key	25 Nm
DPX/DPX-I 125	Cage terminals	4 mm hex key	6 Nm
DPX/DPX-I 160	Connection plates or cage terminals	5 mm hex key	10 Nm
DPX/DPX-I 250 ER	Connection plates	5 mm hex key	10 Nm
	Cage terminals	5 mm hex key	12 Nm
DPX/DPX-I 250	Connection plates	6 mm hex key	15 Nm
	Cage terminals	5 mm hex key	12 Nm
DPX/DPX-I 630	Connection plates or cage terminals	8 mm hex key	25 Nm
DPX/DPX-I 1250-1600	Connection plates	8 mm hex key	25 Nm
Busbars	Mounting screws of isolating supports	10 mm spanner	7.5 Nm
	M8 screws (min. 8-8) for connection on bars	13 mm spanner	15-20 Nm
	M10 screws (min. 6-8) for connection on bars	17 mm spanner	30-35 Nm
	M10 screws (min. 8-8) for connection on bars	17 mm spanner	40-50 Nm
	M12 screws (min. 6-8) for connection on bars	19 mm spanner	50-60 Nm
	M12 screws (min. 8-8) for connection on bars	19 mm spanner	70-85 Nm
Modular distribution blocks	Connection screws	5.5 mm or PZ 2 screwdriver	2 Nm
		6 mm hex key	15 Nm
		5 mm hex key	10 Nm
		4 mm hex key	6 Nm
		6.5 mm screwdriver or 7 mm spanner	2.5 Nm
		10 mm screwdriver or 10 mm spanner	7.5 Nm
Power distribution blocks	Connection screws	13 mm spanner	15 Nm
		3.5 mm screwdriver	0.8 Nm
		4 mm screwdriver	1.4 Nm
		5.5 mm screwdriver	2 Nm
Viking terminal blocks	5 mm pitch	3.5 mm screwdriver	0.8 Nm
	6 and 8 mm pitch	4 mm screwdriver	1.4 Nm
	10 mm pitch	5.5 mm screwdriver	2 Nm
	12 mm pitch	5.5 mm or PZ 2 screwdriver	2 Nm
	15 mm pitch	6.5 mm or PZ 2 screwdriver	4 Nm
XL ³ enclosures	22 mm pitch	6 mm hex key	15 Nm
	M6 screws	10 mm spanner	10 Nm
	M8 screws	13 mm spanner	15 Nm

LIST OF TEST REPORTS

Test	Enclosure	Certificate number	Type of certificate	Language
Glow wire	XL ³ 160 flush-mounting/insulated/metal	A18/2005	Legrand	French
	XL ³ 400 insulated/metal	A19/2005	Legrand	French
	XL ³ 400 IP 55	A25/2005	Legrand	French
	XL ³ 800	A20/5005	Legrand	French
	XL ³ 800 IP 55	A26/2005	Legrand	French
	XL ³ 4000	A21/2005	Legrand	French
IP - IK	XL ³ 160 insulated	A96/2005	Legrand	French
	XL ³ 160 metal	A95/2005	Legrand	French
	XL ³ 400 insulated	A98/2005	Legrand	French
	XL ³ 400 metal	A97/2005	Legrand	French
	XL ³ 800	A99/2005	Legrand	French
	XL ³ 4000	A124/2005	Legrand	French
Temperature rise	XL ³ 160 flush-mounting	IT 05.041	LOVAG	English
	XL ³ 160 insulated	IT 04.034	LOVAG	English
	XL ³ 160 metal	IT 05.058	LOVAG	English
	XL ³ 400 insulated	IT 05.001	LOVAG	English
	XL ³ 400 metal	IT 04.035	LOVAG	English
	XL ³ 4000	IT 06.051	LOVAG	English
Short-circuit	XL ³ 160 flush-mounting	IT 05.051	LOVAG	English
	XL ³ 160 insulated	IT 04.050	LOVAG	English
	XL ³ 160 metal	IT 05.065	LOVAG	English
	XL ³ 400 insulated	IT 04.123	LOVAG	English
	XL ³ 400 metal	IT 04.023	LOVAG	English
	XL ³ 800	IT 06.037	LOVAG	English
	XL ³ 800 IP 55	IT 06.026	LOVAG	English
	XL ³ 4000 + busbar trunking (2500 A)	IT 06.063	LOVAG	English
	XL ³ 4000 + busbar trunking (3200 A)	IT 06.065	LOVAG	English
	XL ³ 4000 Form 4b	IT 06.025	LOVAG	English

Declaration of conformity

Company: Document No.: date:

Address: Assembly No.: date:
..... (if different)

Recipient: Standard IEC 60439-1
Standard IEC 60439-3

The registrant hereby certifies by this document that the whole low voltage assembly derived from the standard (ADS) designated above has been executed according to the requirements of standard IEC 60439-1/IEC 60439-3

The implementation was carried out according to the manufacturer's recommendations.

The following products were used:

- Legrand power circuit breakers conforming to standard IEC 60947-2
- Legrand modular circuit breakers conforming to standard IEC 60898-1
- Legrand distribution blocks and busbar supports
- XL³ enclosures

In reference to the type tests carried out by Legrand

- According to EN 60439-1 and EN 60439-3
 - Checking the temperature rise limits
 - Checking the dielectric properties
 - Checking the short-circuit resistance
 - Checking the effectiveness of protective circuit
 - Checking the clearances and creepage distances
 - Checking the mechanical operation
 - Checking the degree of protection (IP)
- According to EN 60439-3 (additional tests, less than 250 A assemblies)
 - Checking the resistance to mechanical impacts
 - Checking the rust resistance
 - Checking the resistance to damp
 - Checking the resistance of insulating materials to heat
 - Checking the fire resistance
 - Checking the mechanical performance of assemblies and fixings

Individual tests are the subject of individual inspection report No.:
including, according to the standard:

- Checking the insulation
- Checking the continuity of protective circuit
- Visual inspection of the assembly

The registrant:

Individual inspection report

Panel builder: Document no.: date:

Address: Assembly no.: date:
..... (if different)

Command No.

Sequence of individual tests carried out on low voltage assembly according to standard IEC 60439-1/IEC 60439-3

Equipment used for tests and measurement:

.....
.....

Visual inspection

- Conductors and wiring
- Compliance with the scheme
- Equipment
- Compliance with specified equipment
- Busbars
- Electric connection of the chassis and structure
- Provision specific to class II
- Electrical operation (power circuits)
- Electrical operation (command circuits)
- Measurement devices
- Residual current devices
- Mechanical operation
- Compliance with locking and immobilisation specifications
- Tightening torques
- Handling devices
- Maintenance of the degree of protection

Done

Non applicable

<input type="checkbox"/>	<input type="checkbox"/>
<input type="checkbox"/>	<input type="checkbox"/>
<input type="checkbox"/>	<input type="checkbox"/>
<input type="checkbox"/>	<input type="checkbox"/>
<input type="checkbox"/>	<input type="checkbox"/>
<input type="checkbox"/>	<input type="checkbox"/>
<input type="checkbox"/>	<input type="checkbox"/>
<input type="checkbox"/>	<input type="checkbox"/>
<input type="checkbox"/>	<input type="checkbox"/>
<input type="checkbox"/>	<input type="checkbox"/>
<input type="checkbox"/>	<input type="checkbox"/>
<input type="checkbox"/>	<input type="checkbox"/>
<input type="checkbox"/>	<input type="checkbox"/>
<input type="checkbox"/>	<input type="checkbox"/>
<input type="checkbox"/>	<input type="checkbox"/>
<input type="checkbox"/>	<input type="checkbox"/>

Checking the insulation

- Dielectric test (voltage:)
- Insulation resistance at 500 V (minimum measured value:)

<input type="checkbox"/>	<input type="checkbox"/>
<input type="checkbox"/>	<input type="checkbox"/>

Checking the continuity of the protective circuits

- Measuring of the continuity resistance at 25 A
- Checking with tester with signal

<input type="checkbox"/>	<input type="checkbox"/>
<input type="checkbox"/>	<input type="checkbox"/>

Final control

- Presence of nameplate
- Presence of documentation

<input type="checkbox"/>	<input type="checkbox"/>
<input type="checkbox"/>	<input type="checkbox"/>

Verified by:

Approved by:

Date:

POWER GUIDE: A complete set of technical documentation



01 | Sustainable development and energy efficiency



08 | Protection against external disturbances



02 | Power balance and choice of power supply solutions



09 | Operating functions



03 | Electrical energy supply



10 | Enclosures and assembly certification



04 | Sizing conductors and selecting protection devices

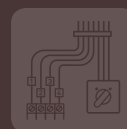

11 | Cabling components and control auxiliaries



05 | Breaking and protection devices

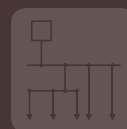

12 | Busbars and distribution



06 | Electrical hazards and protecting people



13 | Transport and distribution inside an installation



07 | Protection against lightning effects



Annexes
Glossary
Lexicon



World Headquarters and International Department
87045 Limoges Cedex - France
☎ : + 33 (0) 5 55 06 87 87
Fax : + 33 (0) 5 55 06 74 55