

Guide for the Design and Production of LV Power Factor Correction Cubicles

Power Quality

Panel Builder Guide
2018





Green Premium™

Endorsing the most eco-friendly products in the industry



Green Premium™ Product

Green Premium is the only label that allows you to effectively develop and promote an environmental policy whilst preserving your business efficiency. This ecolabel guarantees compliance with the most up-to-date environmental regulations, but it does more than this.

Over 75% of Schneider Electric manufactured products have been awarded the Green Premium ecolabel



Discover what we mean by green

Check your products!

Schneider Electric's Green Premium ecolabel is committed to offering transparency, by disclosing extensive and reliable information related to the environmental impact of its products:

RoHS

Schneider Electric products are subject to RoHS requirements at a worldwide level, even for the many products that are not required to comply with the terms of the regulation. Compliance certificates are available for products that fulfil the criteria of this European initiative, which aims to eliminate hazardous substances.

REACH

Schneider Electric applies the strict REACH regulation on its products at a worldwide level, and discloses extensive information concerning the presence of SVHC (Substances of Very High Concern) in all of these products.

PEP: Product Environmental Profile

Schneider Electric publishes the most complete set of environmental data, including carbon footprint and energy consumption data for each of the lifecycle phases on all of its products, in compliance with the ISO 14025 PEP ecopassport program. PEP is especially useful for monitoring, controlling, saving energy, and/or reducing carbon emissions.

EoLI: End of Life Instructions

Available at the click of a button, these instructions provide:

- Recyclability rates for Schneider Electric products.
- Guidance to mitigate personnel hazards during the dismantling of products and before recycling operations.
- Parts identification for recycling or for selective treatment, to mitigate environmental hazards/ incompatibility with standard recycling processes.

General design rules	3
Applicable standards and definitions	
Reactive Energy Guidelines	
Benefits of reactive energy management	
Calculation of reactive energy	
Selection of compensation mode	
Effects of Harmonics	
<hr/>	
Component Selection Guide	12
Capacitors	12
Rated Voltage and Current of Capacitor	
Capacitors selection based on operating conditions	
Offer overview – EasyCan, VarPlus Can & VarPlus Box	
Safety features in Capacitors	
Detuned Reactors	23
Detuned reactors overview	
Capacitor Selection with Detuned reactor	
Choice of Detuned Reactor Tuning Frequency	
Offer overview- Detuned reactors	
EasyCan applications with reactors	
VarPlus Can applications with reactor	
Contactors	33
Offer overview – TeSys D Contactors	
Parallel Operation of Capacitors and Inrush Current Limiting	
Switching and Protection Devices	36
Power Factor Controller	37
Offer Overview - VarPlus logic power factor controller	
Physical and Electrical control of PFC relay	
CT and Protection Devices	43
Current Transformer	
Protection Devices in APFC Panels	
Switchgear selection	
<hr/>	
Installation Rules	47
Capacitor	47
Detuned Reactors	49
Automatic Power Factor Correction (APFC) banks	50
Maximum kvar per step in APFC Panels	
Installation rules - APFC Panels	
Thermal safety in APFC panels	
Protection of panels	
Cable selection	
<hr/>	
Assembly, Inspection and Testing	59
<hr/>	
Handling	65
<hr/>	
Installation, Commissioning and Maintenance	68
Pre-Commissioning check lists	
Installation guidelines for APFC Panels	
Commissioning of APFC Panel	
Periodic maintenance	
<hr/>	
ANNEXURE	71
Annexure 1: Trouble shooting in capacitor	
Annexure 2: Important analysis formulas	

Design of LV compensation cubicle

In addition to the rules and standards, production of electrical switchboards for the LV compensation requires consideration of specific constraints.



Disclaimer

This guide cannot be used to define or determine the suitability or reliability of these equipment/Products explained in this document for specific user applications.

At each stage of equipment order fulfillment lifecycle (Design, Manufacturing, Testing, Installation & Commissioning), it is the duty of any such panel builder or integrator to perform appropriate study and evaluation of the specific user application or use thereof.

The performance and safety of the equipment or products used in the equipment shall be the sole responsibility of the panel builder/ Integrator.

1- The compensation modules

The VarPlus and EasyCan capacitors

Their positioning must ensure proper ventilation.

Their sizing must take into account ambient conditions (harmonics, temperature, etc...)

The Contactors

They must be suited to capacitor control. Schneider Electric has designed and tested specific contactors for this application. Their control voltage must be monitored in order to prevent rapid reclosing.

2- The Detuned Reactors (DR)

They must be chosen according to harmonic stresses and installed in order to avoid, as far as possible, capacitor temperature rise.

The DR temperature sensor must be connected so that the step can be disconnected if the temperature is too high

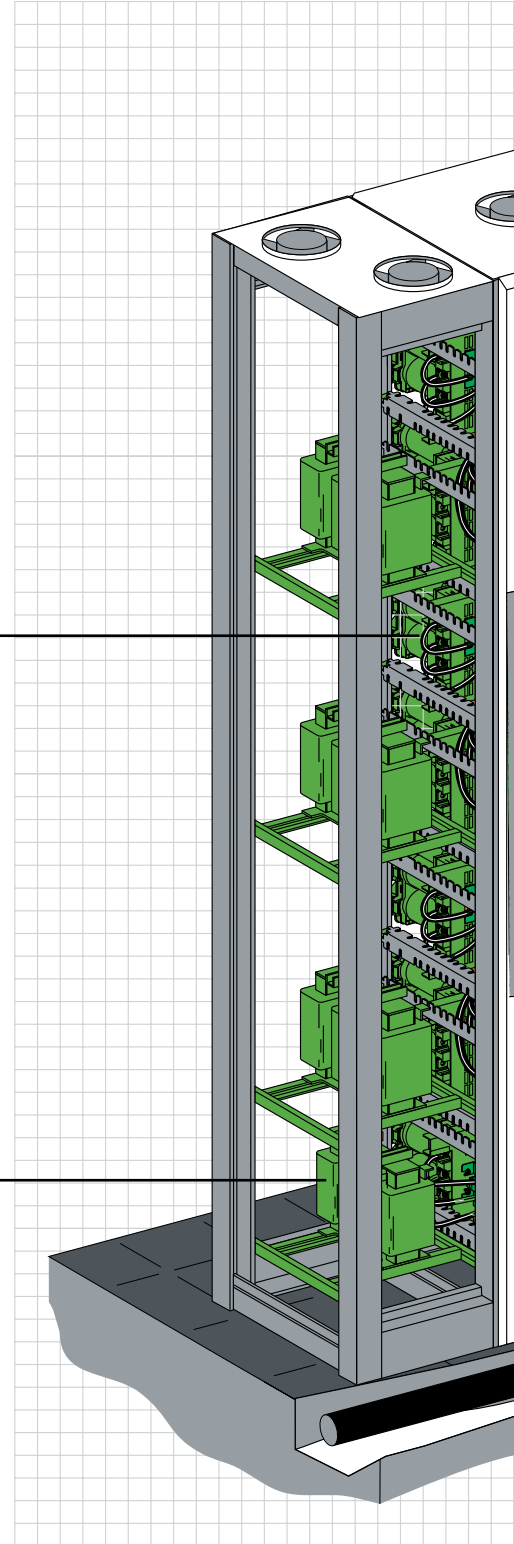

Key points discussed in the document

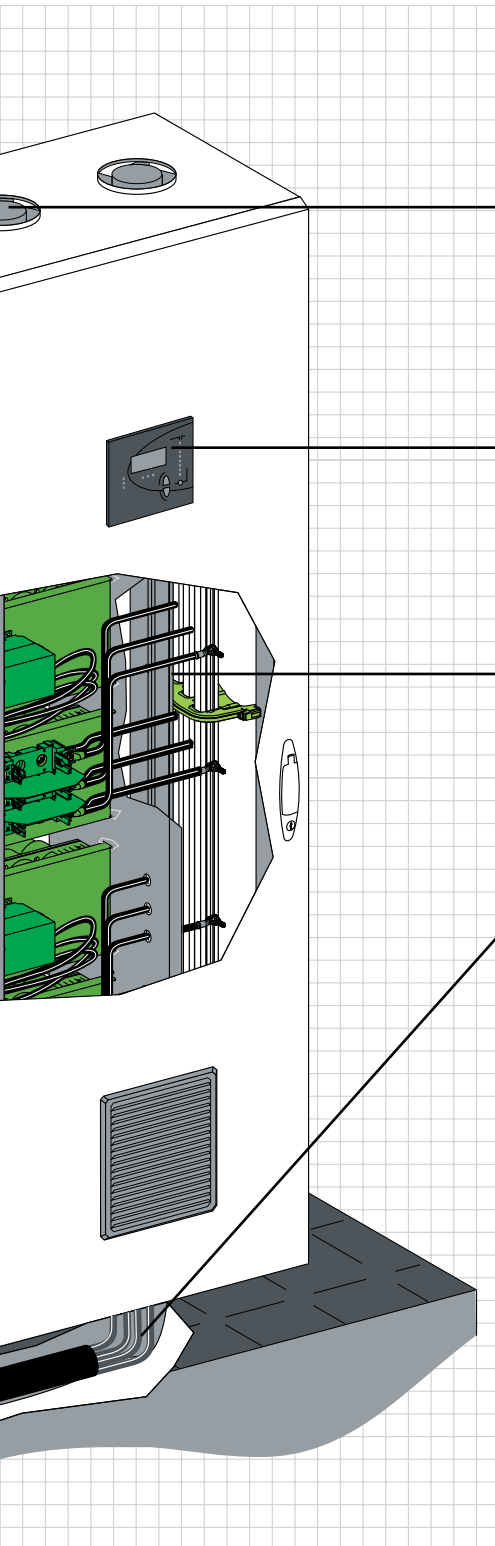

3- Ventilation

It must be efficient in order to keep operating temperature lower than maximum permissible temperature of components.

4- The power factor controller

Its functions must be adapted to the capacitor bank characteristics: number and power of steps, sequence, etc. The time delay must be adapted to capacitor discharge time.

5- Step protection with circuit breakers

It is mandatory to use MCCB or MCB for the individual step against over current and short circuit protection. Make sure to set the thermal setting of the MCCB according to the kvar rating.

6- Low voltage network

Network characteristics, and in particular network harmonic distortion, must absolutely be taken into account when choosing capacitors and detuned reactors (if any).

7- Tests to be done after production of the bank

At the end of the manufacturing process, a LV switchboard must undergo various routine inspections and tests in the factory, following an established programme.

The switchboard must comply with :

- the appropriate standards
- the design file (drawings, diagrams and specific requirements)
- manufacturer mounting instructions
- in-house instructions.

8- Maintenance must be done every year

One month after energising, check all contactor terminal tightening torques.

Annual checks

- General cleanliness of the equipment
- Filters and ventilation system
- Terminal tightening torques
- Proper working order of switching and protective devices
- Temperature in the premises:
-5 °C to +40 °C max - for normal designs
- Capacitance: It is recommended to change the capacitor if the capacitance value has reduced more than 10%.

Applicable standards and definitions

Applicable Standards

- **IEC 61921:** (Power Capacitors- Low voltage power factor correction banks) is the international standard applicable for Low Voltage Power Factor Correction Banks and Automatic Power Factor Correction (APFC) equipments intended to be used for power factor correction purposes, equipped with built in switch gears and control gears. The guidelines for design, installation, operation and safety of APFC panels are followed based on this international standard.
- **IEC 60831:** Part 1 & 2-Shunt power capacitors of the self healing type for a.c systems having rated voltage up to and including 1kV.
- **IEC 61439-1:** Low voltage switchgear and control gear assemblies. Particular requirements for low-voltage switchgear and control gear assemblies intended to be installed in places where unskilled persons have access for their use-Distribution boards.
- **IEC 60947:** Low Voltage Switchgear
 - Part 2: Molded Case Circuit Breakers & Air circuit Breakers
 - Part 4: Power Contactors
 - Part 4-3: Thyristor Switch
- **IEC 60076-6:** Reactors.
- **IEC 60529:** Degree of protection provided by enclosure (IP code).
- **IEC 60664-1 / IEC 61326:** Power Factor Controller.
- **IEC 62208:** Empty enclosures for low-voltage switchgear and controlgear assemblies – General requirements.

Definitions

The design of the APFC equipment involves the following major parts and the selection of these depends very much on the above system conditions.

Enclosure: protects the APFC system components against the external solid or liquid particles and also provide protection for human beings.

PFC Controller: Is the brain of the APFC system, which switches ON / OFF the steps depending on the kvar required in order to maintain the PF close to unity.

Bus bars: Bus bar is the electrical conducting path, to which all the components in the APFC system are connected.

Switchgears: Switchgears are the devices which control the circuit under faulty and normal conditions. Switchgears protect the APFC system against faulty conditions.

Cables: Cables are used to connect various components in the steps. Proper cable sizing has to be considered for a particular step depending on the rated current and the operating temperature in order to link the various components of the system. Cables loop the power circuit & control circuit in the system.

Protection devices: Protection has to be provided to safeguard the capacitors and other components due to abnormalities in the system. The incoming switchgear of the

APFC system should be tripped by protective devices.

Reactors: Reactors are used in steps as detuned filters and are connected in series with capacitors. It must be designed to withstand fundamental and harmonic currents.

Capacitors: Capacitors forms the core component in APFC equipment and plays a vital role in power factor correction. Proper selection of capacitors is very much necessary to comply with the applications.

Note: The above components are explained further in details

Glossary

ACB	: Air Circuit Breaker
MCCB	: Molded Case Circuit Breaker
HRC	: High Rupture Capacity Fuse
SMC	: Sheet Molding Compound
DMC	: Dough Molding Compound

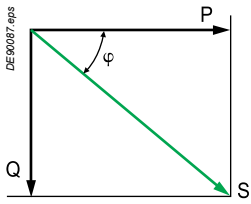

Principle of reactive energy management

All AC electrical networks consume two types of power: active power (kW) and reactive power (kvar):

- **The active power P** (in kW) is the real power transmitted to loads such as motors, lamps, heaters, computers ... The electrical active power is transformed into mechanical power, heat or light.
- **The reactive power Q** (in kvar) is used only to supply the magnetic circuits of machines, motors and transformers.
- **The apparent power S** (in kVA) is the vector combination of active and reactive power.

In this representation, the **Power Factor** (P/S) is equal to $\cos\phi$.

The circulation of reactive power in the electrical network has major technical and economic consequences. For the same active power P, a higher reactive power means a higher apparent power and thus, a higher current must be supplied.

- The circulation of active power over time is resulting in active energy (in kWh).
- The circulation of reactive power over time is resulting in reactive energy (kvarh).
- In an electrical circuit, the reactive energy is supplied in addition to the active energy.

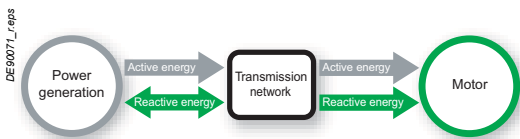

Reactive energy supplied and billed by the energy supplier

Due to this higher supplied current, circulation of reactive energy on distribution networks results in:

- Overload of transformers,
- Higher temperature rise of the supply cables,
- Additional losses,
- Large voltage drops,
- Higher energy consumption and cost,
- Less distributed active power.

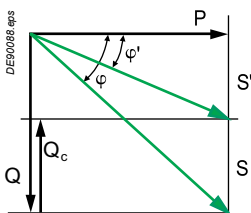

For these reasons, there is a great advantage to generate reactive energy at the load level in order to prevent the unnecessary circulation of current in the network. This is what is known as "Power Factor Correction".

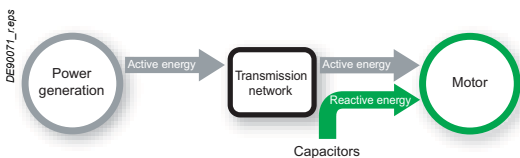

This is obtained by the connection of capacitors, which produce reactive energy in opposition to the energy absorbed by loads such as motors.

The result is a reduced apparent power, and an improved power factor P/S' as illustrated on the diagram on the left.

The power generation and transmission networks are partially relieved, reducing power losses and making additional transmission capability available.

Since the reactive power is supplied by capacitors there is no billing of reactive power by the utility (energy supplier).

Benefits of reactive energy management

Optimized management of reactive energy brings economic and technical advantages.

Savings on the electricity bill:

- Eliminating penalties on reactive energy and decreasing kVA demand,
- Reducing power losses generated in the transformers and conductors of the installation.

Example:

Loss reduction in a 630 kVA transformer

PW = 6,500 W with an initial Power Factor = 0.7.

With power factor correction, we obtain a final Power Factor = 0.98

The losses become: 3,316 W, i.e. a reduction of 49%.

Increasing available power:

A high power factor optimizes an electrical installation by allowing a better usage of the components.

The power available at the secondary of an MV/LV transformer can therefore be increased by fitting power factor correction equipment at the low voltage side.

The table shows the increased available power at the transformer output by improvement of Power Factor from 0.7 to 1.

Power factor	Increased available power
0.7	0%
0.8	+14%
0.85	+21%
0.90	+28%
0.95	+36%
1	+43%

Power factor	Cable cross-section multiplying factor
1	1
0.80	1.25
0.60	1.67
0.40	2.50

Reducing the installation size

Installing power factor correction equipment allows the conductors cross-section to be reduced, since less current is absorbed by the compensated installation for the same active power.

The table in the left shows the multiplying factor for the conductor cross-section according to the different values of power factor.

Reducing the voltage drops on installation

Installing capacitors allows the voltage drops to be reduced upstream of the point where the power factor correction device is connected. It avoids the overload of the network and allows the diminution of harmonics so that no overrating of the installation is necessary.

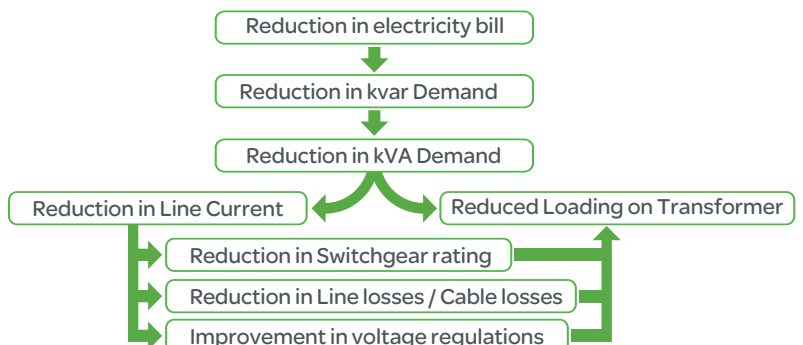

Power Factor Correction guidelines

The selection of the Power Factor Correction equipment can follow a 4-step process:

1. Calculation of the requested reactive energy,

2. Selection of the compensation mode:

- Global, for the complete installation,
- By sectors,
- For individual loads, such as large motors.

3. Selection of the compensation type:

- Fixed, by connection of a fixed-value capacitor bank,
- Automatic, by connection of different number of steps, allowing the adjustment of the reactive energy to the requested value,
- Dynamic, for compensation of highly fluctuating loads.

4. Taking account of operating conditions and harmonics

Calculation of Reactive Energy Based on the Application

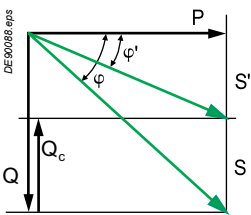
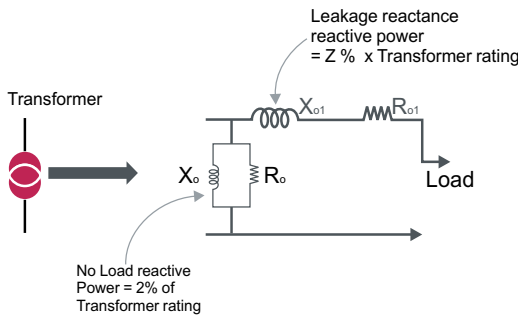

Power Factor Correction for Transformer no-load compensation

The transformer works on the principle of Mutual Induction. The transformer will consume reactive power for magnetizing purpose.

Following equivalent circuit of transformer provides the details of reactive power demand inside the transformer:

kVA rating of Transformer	kvar required for No-Load compensation
Up to and including 2000 kVA	2% of kVA rating

Power Factor Correction where Load and present Power Factor is Known

The objective is to determine the requested reactive power Q_C (kvar) to be installed, in order to improve the power factor $\cos\phi$ and reduce the apparent power S .

For $\phi' < \phi$, we'll get: $\cos\phi' > \cos\phi$ and $\tan\phi' < \tan\phi$

This is illustrated on the diagram in the left.

Q_C can be determined from the formula: $Q_C = P \cdot (\tan\phi - \tan\phi')$, which is deduced from the diagram.

Q_C : power of the capacitor bank, in kvar

P : active power, in kW

$\tan\phi$: tangent of the phase angle - before compensation,

$\tan\phi'$: tangent of the phase angle - after compensation

The parameters ϕ and $\tan\phi$ can be obtained from the billing data, or from direct measurement in the installation.

The following table can be used for direct determination.

Before compensation		Reactive power (kvar) to be installed per kW of load, in order to get the requested $\tan\phi'$ or $\cos\phi'$							
$\tan\phi$	$\cos\phi$	$\tan\phi'$	0.75	0.62	0.48	0.41	0.33	0.23	0.00
		$\cos\phi'$	0.8	0.85	0.9	0.925	0.95	0.975	1.00
1.73	0.5		0.98	1.11	1.25	1.32	1.40	1.50	1.73
1.02	0.7		0.27	0.40	0.54	0.61	0.69	0.79	1.02
0.96	0.72		0.21	0.34	0.48	0.55	0.64	0.74	0.96
0.91	0.74		0.16	0.29	0.42	0.50	0.58	0.68	0.91
0.86	0.76		0.11	0.24	0.37	0.44	0.53	0.63	0.86
0.80	0.78		0.05	0.18	0.32	0.39	0.47	0.57	0.80
0.75	0.8			0.13	0.27	0.34	0.42	0.52	0.75
0.70	0.82			0.08	0.21	0.29	0.37	0.47	0.70
0.65	0.84			0.03	0.16	0.24	0.32	0.42	0.65
0.59	0.86				0.11	0.18	0.26	0.37	0.59
0.54	0.88				0.06	0.13	0.21	0.31	0.54
0.48	0.9					0.07	0.16	0.26	0.48

Note: It is widely accepted to use a rule of thumb that Motor compensation required in kvar is equal to 33% of the Motor Rating in HP.

But it is always suggested to check the name plate of a motor and find out the kvar required using the above mentioned method (using the above table) for accurate compensation.

Example:

Consider one 1000kW motor with $\cos\phi$ 0.8 ($\tan\phi = 0.75$).

In order to get $\cos\phi' = 0.95$, it is necessary to install a capacitor bank with a reactive power equal to

$k \times P$, i.e. : $Q_c = 0.42 \times 1000 = 420$ kvar

Selection of the compensation mode

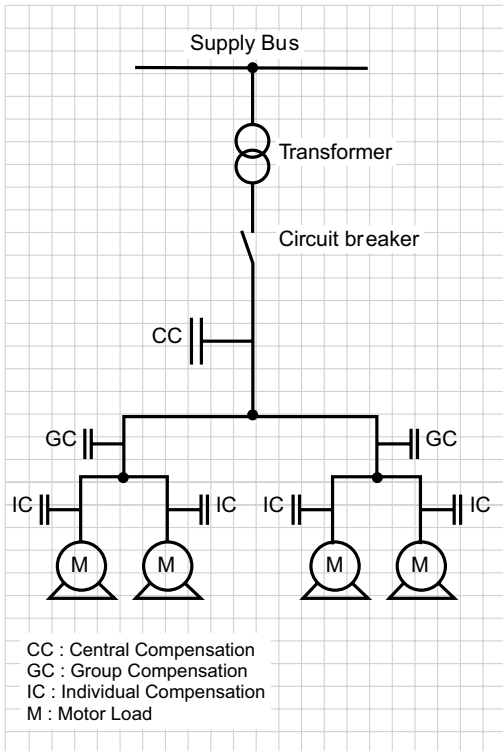

The location of low-voltage capacitors in an installation constitutes the mode of compensation, which may be global (one location for the entire installation), by sectors (section-by-section), at load level, or some combination of the latter two. In principle, the ideal compensation is applied at a point of consumption and at the level required at any instant.

In practice, technical and economic factors govern the choice.

The place for connection of capacitor banks in the electrical network is determined by:

- Global objective (avoid penalties on reactive energy, relieve of transformer or cables, avoid voltage drops and sags),
- Operating mode (stable or fluctuating loads),
- Foreseeable influence of capacitors on the network characteristics,
- Installation cost.

Global compensation

The capacitor bank is connected at the head of the installation to be compensated in order to provide reactive energy for the whole installation. This configuration is convenient for stable and continuous load factor.

Compensation by sectors

The capacitor bank is connected at the head of the feeders supplying one particular sector to be compensated. This configuration is convenient for a wide installation, with workshops having different load factors.

Compensation of individual loads

The capacitor bank is connected right at the inductive load terminals (especially large motors). This configuration is well adapted when the load power is significant compared to the subscribed power. This is the technical ideal configuration, as the reactive energy is produced exactly where it is needed, and adjusted to the demand.

Selection of the compensation type

Different types of compensation shall be adopted depending on the performance requirements and complexity of control:

- Fixed, by connection of a fixed-value capacitor bank,
- Automatic, by connection of different number of steps, allowing the adjustment of the reactive energy to the requested value,
- Dynamic, for compensation of highly fluctuating loads.

Fixed compensation

This arrangement uses one or more capacitor(s) to provide a constant level of compensation. Control may be:

- Manual: by circuit-breaker or load-break switch,
- Semi-automatic: by contactor,
- Direct connection to an appliance and switched with it.

These capacitors are applied:

- At the terminals of inductive loads (mainly motors),
- At bus bars supplying numerous small motors and inductive appliances for which individual compensation would be too costly,
- In cases where the load factor is reasonably constant.

Automatic compensation

This kind of compensation provides automatic control and adapts the quantity of reactive power to the variations of the installation in order to maintain the targeted $\cos \varphi$. The equipment is applied at points in an installation where the active-power and/or reactive-power variations are relatively large, for example:

- At the busbars of a main distribution switch-board,
- At the terminals of a heavily-loaded feeder cable.

Where the kvar rating of the capacitors is less than, or equal to 15% of the supply transformer rating, a fixed value of compensation is appropriate. Above the 15% level, it is advisable to install an automatically-controlled bank of capacitors.

Control is usually provided by contactors. For compensation of highly fluctuating loads, fast and highly repetitive connection of capacitors is necessary, then static switches must be used.

Dynamic compensation

This kind of compensation is requested when fluctuating loads are present, and voltage fluctuations should be avoided. The principle of dynamic compensation is to associate a fixed capacitor bank and an electronic var compensator, providing either leading or lagging reactive currents.

The result is a continuously varying and fast compensation, perfectly suitable for loads such as lifts, crushers, spot welding

...

Harmonics in electrical installations

The presence of harmonics in electrical systems means that current and voltage are distorted and deviate from sinusoidal waveforms.

Harmonic currents are currents circulating in the networks and which frequency is an integer multiple of the supply frequency. Harmonic currents are caused by non-linear loads connected to the distribution system. A load is said to be non-linear when the current it draws does not have the same waveform as the supply voltage. The flow of harmonic currents through system impedances in turn creates voltage harmonics, which distort the supply voltage.

The most common non-linear loads generating harmonic currents are using power electronics, such as variable speed drives, rectifiers, inverters, etc.... Loads such as saturable reactors, welding equipment, arc furnaces, also generate harmonics. Other loads such as inductors, resistors and capacitors are linear loads and do not generate harmonics.

Influence of Harmonics in Capacitors

Capacitors are particularly sensitive to harmonic currents since their impedance decreases proportionally to the order of the harmonics present. This can result in a capacitor overload, shortening steadily its operating life. In some extreme situations, resonance can occur, resulting in an amplification of harmonic currents and a very high voltage distortion.

Amplification of Harmonic currents is very high when the natural resonance frequency of the capacitor and the network combined happens to be close to any of the harmonic frequencies present.

This situation could result in severe over voltages and overloads which will lead to premature failure of capacitors

To ensure a good and proper operation of the electrical installation, the harmonic level must be taken into account in the selection of the power factor correction equipment. A significant parameter is the cumulated power of the non-linear loads generating harmonic currents.

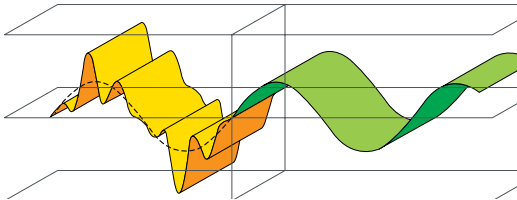

Equipment	Effect of Harmonics
Motor	Over heating, production of non-uniform torque, increased vibration
Transformer	Over heating and insulation failure, noise
Switch gear and cables	Neutral link failure, increased losses due to skin effect and over heating of cables
Capacitors	Life reduces drastically due to harmonic overloading
Protective Relays	Malfunction and nuisance tripping
Power electronic equipment	Misfiring of Thyristors and failure of semiconductor devices
Control & instrumentation Electronic equipment	Erratic operation followed by nuisance tripping and breakdowns
Communication equipment / PC's	Interference
Neutral cable	Higher Neutral current with 3 rd harmonic frequency, Neutral over heating and or open neutral condition
Telecommunication equipment	Telephonic interference, malfunction of sensitive electronics used, failure of telecom hardware

Rated voltage and current of Capacitor

According to IEC 60831-1 standard, the rated voltage (U_N) of a capacitor is defined as the continuously admissible operating voltage.

The rated current (I_N) of a capacitor is the current flowing through the capacitor when the rated voltage (U_N) is applied at its terminals, supposing a purely sinusoidal voltage and the exact value of reactive power (kvar) generated.

Capacitor units shall be suitable for continuous operation at an r.m.s. current of $(1.3 \times I_N)$.

In order to accept system voltage fluctuations, capacitors are designed to sustain over-voltages of limited duration. For compliance to the standard, capacitors are for example requested to sustain over-voltages equal to 1.1 times U_N , 8h per 24h.

VarPlus range of capacitors have been designed and tested extensively to operate safely on industrial networks. The design margin allows operation on networks including voltage fluctuations and common disturbances. Capacitors can be selected with their rated voltage corresponding to the network voltage. For different levels of expected disturbances, different technologies are proposed, with larger design margin for capacitors adapted to the most stringent working conditions.

CAUTION: the life expectancy will be reduced if capacitors are used at the maximum level of the working conditions.

Admissible voltage levels in service as per IEC 60831-1-2014

Voltage factor $\times U_N$ r.m.s.	Maximum duration	Observations
1,00	Continuous	Highest average value during any period of capacitor energisation. For energization periods less than 24h, exceptions apply as indicated below (see clause 29).
1,10	8h in every 24h	System voltage regulation and fluctuations
1,15	30min in every 24h	System voltage regulation and fluctuations
1,20	5min	Voltage rise at light load (see clause 29)
1,30	1 min	

Capacitor Selection Based on operating conditions

The operating conditions have a great influence on the life expectancy of capacitors. For this reason, different categories of capacitors, with different withstand levels, must be selected according to operating conditions.

Capacitors must be selected in function of the following parameters:

- Ambient Temperature (°C),
- Expected over-current, related to voltage disturbances, including maximum sustained over voltage,
- Maximum number of switching operations/year,
- Requested life expectancy.

Capacitors are particularly sensitive to harmonics. Depending on the magnitude of harmonics in the network, different configurations shall be adopted.

Different ranges with different levels of ruggedness are proposed:

EasyCan: Standard duty capacitors for standard operating conditions, and when no significant non-linear loads are present.

VarPlus: Heavy duty capacitors for difficult operating conditions, particularly voltage disturbances, or when a few non-linear loads are present. The rated current of capacitors must be increased in order to cope with the circulation of harmonic currents.

Capacitors with detuned reactors: applicable when a significant number of non-linear loads are present.

Tuned filters: when non-linear loads are predominant, requesting harmonic mitigation. A special design is generally necessary, based on on-site measurements and computer simulations of the network.

Since the harmonics are caused by non-linear loads, an indicator for the magnitude of harmonics is the ratio of the total power of non-linear loads to the supply transformer rating.

This ratio is noted N_{LL} , and is also known as G_h/S_n :

$$N_{LL} = \frac{\text{Total power of non-linear loads } (G_h)}{\text{Installed transformer rating } (S_n)}$$

Example:

Supply transformer rating: $S_n = 630 \text{ kVA}$

Total power of non-linear loads: $G_h = 150 \text{ kVA}$

$N_{LL} = (150/630) \times 100 = 24\%$

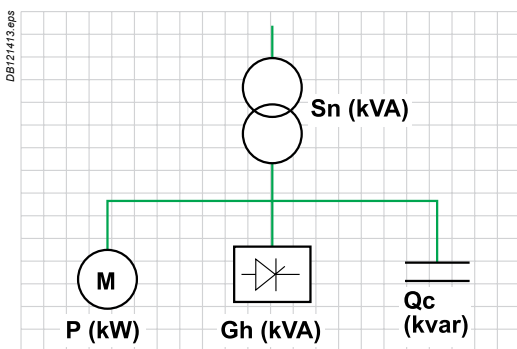

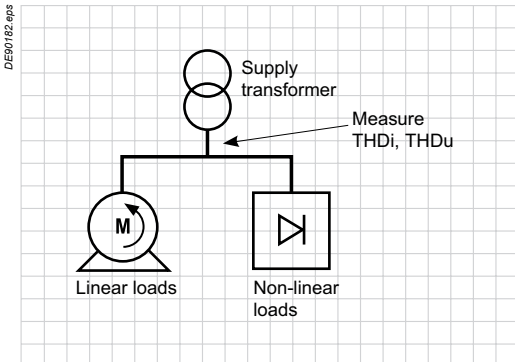

User Tip:

Systems with $N_{LL} > 20\%$ may require to install active filters for effective harmonic mitigation over and above the power factor correction with capacitor banks.

All installations with active filters for harmonic mitigation **should not** use capacitor banks without detuned reactors for power factor correction.

Capacitor selection taking account of harmonics

The percentage of non-linear loads N_{LL} is a first indicator for the magnitude of harmonics. The proposed selection of capacitors depending on the value of N_{LL} is given in the diagram below.

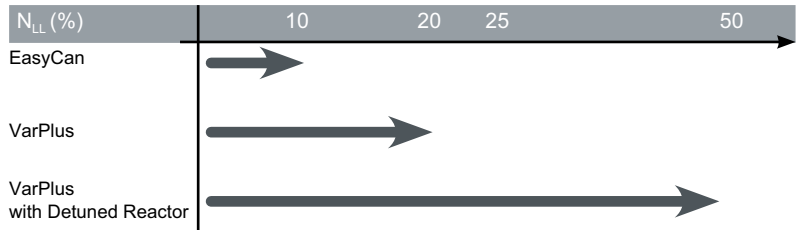

A more detailed estimation of the magnitude of harmonics can be made with measurements. Significant indicators are current harmonic distortion THDi and voltage harmonic distortion THDu, measured at the transformer secondary, with no capacitors connected. According to the measured distortion, different technologies of capacitors shall be selected:

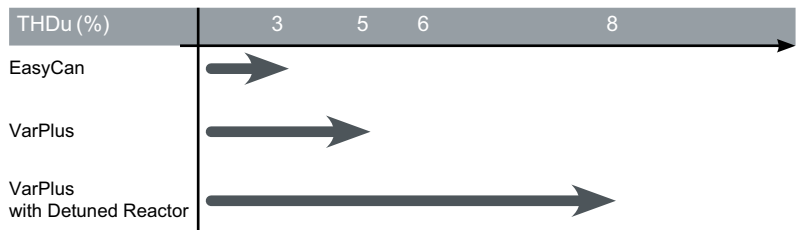
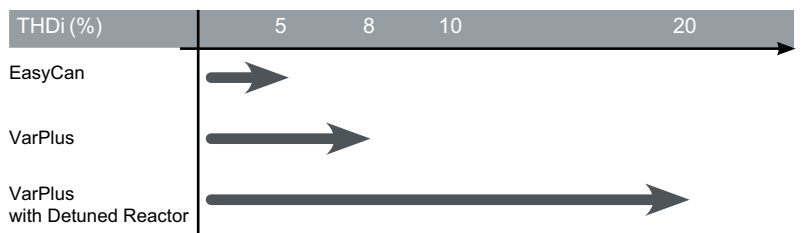

Note:

The capacitor technology has to be selected according to the most restrictive measurement. Example, a measurement is giving the following results :

- THDi = 15 % Harmonic solution.
- THDu = 3.5 % HDuty solution.

VarPlus with Detuned Reactor has to be selected.

Application Limits of Detuned reactor

Tuning Order	Maximum THDu Limit
2.7 (14%)	8%
3.8 (7%)	7%
4.2 (5.7%)	6%

⚠ WARNING

HAZARD OF ELECTRICAL SHOCK OR EQUIPMENT DAMAGE

All the given values for the application limits are indicative. It is highly recommended to do a harmonic study and detailed load study before selecting the compensation type. Please contact Schneider Electric for support. Failure to these instruction can result in injury or equipment damage.



Solution	Description	Recommended use for	Max. condition
EasyCan	Standard capacitor	<ul style="list-style-type: none"> • Networks with non significant non-linear loads • Standard over-current • Ambient temperature • Normal switching frequency • Standard life expectancy 	$N_{LL} \leq 10\%$ $1.5 I_N$ -25 to 55°C (Class D) 5,000/year Up to 100,000 h*
VarPlus Can or Box	Heavy-duty capacitor	<ul style="list-style-type: none"> • Few non-linear loads • Significant over-current • Ambient temperature • Significant switching frequency • Long life expectancy 	$N_{LL} \leq 20\%$ $1.8 I_N$ -25 to 55°C (Class D) 7,000/year Up to 130,000 h*
VarPlus + Detuned Reactor	Heavy-duty, harmonic rated capacitor + detuned reactor	<ul style="list-style-type: none"> • High level of non-linear loads (up to 50%) • Significant over-current • Ambient temperature • Significant switching frequency • Long life expectancy 	$N_{LL} \leq 50\%$ $1.8 I_N$ -25 to 55°C (Class D) 7,000/year Up to 130,000 h*

**The maximum life expectancy is given considering standard operating conditions: service voltage(U_N), service current(I_N), 35°C ambient temperature.*

WARNING: *The life expectancy of the capacitor will be reduced if highest mean temperature exceeds 45°C for 24hours or 35°C for 1 year (Reference: IEC60831).*

An easy choice for savings which is optimized to deliver the performance you need. Suitable for standard operating conditions to deliver safe and reliable performance.

GroupECCapacitors



EasyCan three phase

GroupS_SF_ECCapacitors



EasyCan single phase

Operating conditions

- For networks with insignificant non-linear loads: ($N_{LL} \leq 10\%$).
- Standard voltage disturbances.
- Operating temperature up to 55°C.
- Maximum switching frequency up to 5,000/year.
- Maximum current (including harmonics) is $1.5 \times I_N$.

Easy installation & maintenance

- Optimized design for low weight, compactness and reliability to ensure easy installation and up to 20% space savings in cubicles.
- New CLAMPTITE terminals that allows maintained tightness.
- Non-accessible in-built discharge resistors to ensure safety.
- 1 point for mounting and earthing.
- Simultaneous and safe disconnection of all the phases at end of life in EasyCan.
- Stacked design and resin filled technology for better cooling.

Safety

- Self-healing.
- Pressure-sensitive disconnecter on all three phases.
- Discharge resistors fitted - non removable.
- Finger-proof CLAMPTITE terminals to reduce risk of accidental contact and to ensure firm termination (10 to 30.3 kvar in three phase and 8.3 - 15.1 kvar in single phase).

Technology

Constructed internally with single-phase capacitor elements assembled in an optimized design. Each capacitor element is manufactured with metallized polypropylene film.

The capacitor elements are encapsulated in a specially formulated biodegradable, non-PCB, polyurethane soft resin which ensures thermal stability and heat dissipation from inside the capacitor.

The unique finger-proof CLAMPTITE termination is fully integrated with discharge resistors and allows suitable access to tightening and allows cable termination without any loose connections.

For lower ratings, double fast-on terminals with wires are provided.

Benefits

- Easy installation
- Easy for reliability and safe usage.
- Easy for quality assurance.
- Easy choice for building your solutions with other Schneider Electric components.
- Easy choice for savings.

EasyCanCapacitors



EasyCan3U_3PhaseCapacitors



Technical specifications

General characteristics

Standards	IEC 60831-1/2	
Voltage range	230V to 525V in Three Phase & 220-440V in Single Phase	
Frequency	50 / 60 Hz	
Power range	1 to 30.3 kvar	
Losses (dielectric)	< 0.2 W/kvar	
Losses (total)	< 0.5 W/kvar	
Capacitance tolerance	-5 %, +10 %	
Voltage test	Between terminals	2.15 x U _N (AC), 10 s
	Between terminal & container	3 kV (AC), 10 s or 3.66 kV (AC), 2 s
	Impulse voltage	8 kV
Discharge resistor	Fitted, standard discharge time 60 s	

Working conditions

Ambient temperature	-25 / 55 °C (Class D)
Humidity	95 %
Altitude	2,000 m above sea level
Overvoltage	1.1 x U _N 8 h in every 24 h
Overcurrent	Up to 1.5 x I _N
Peak inrush current	200 x I _N
Switching operations (max.)	Up to 5,000 switching operations per year
Mean Life expectancy	Up to 100,000 hrs
Harmonic content withstand	N _{LL} ≤ 10 %

Installation characteristics

Mounting position	Indoor, upright
Fastening	Threaded M12 stud at the bottom
Earthing	
Terminals	<ul style="list-style-type: none"> ● CLAMPTITE - terminals with electric shock protection (finger-proof) & double fast-on terminal in lower kvar ● Stud type terminal: <ul style="list-style-type: none"> □ Three way stud type terminals for the ratings above 30.3 kvar in three phase capacitors (2 terminals for single phase) □ Two way stud terminals for ratings above 15.1 kvar in single phase

Safety features

Safety	Self-healing + Pressure-sensitive disconnecter + Discharge device
Protection	IP20 (for fast-on and clamptype)

Construction

Casing	Extruded Aluminium Can
Dielectric	Metallized polypropylene film with Zn/Al alloy
Impregnation	Biodegradable, Non-PCB, poly urethane soft resin

⚠ WARNING

HAZARD OF ELECTRICAL SHOCK

Wait 5 minutes after isolating supply before handling

 Failure to follow these instructions can result in injury or equipment damage

A safe, reliable, high-performance and flexible solution for power factor correction in stringent operating conditions to maximise your savings

Original Capacitors/VarPlus



VarPlus Can

Operating conditions

- For networks with insignificant non-linear loads: ($N_{LL} < 20\%$).
- Significant voltage disturbances.
- Operating temperature up to 55°C.
- Maximum switching frequency up to 7,000/year.
- Over current handling(including harmonics) up to $1.8 \times I_N$.

High performance and flexibility with VarPlus Can

- Power ratings up to 57.1 kvar in single can and compactness across the range to reduce your cubicle space up to 40%.
- Build your type tested Schneider electric solution with VarPlus Can – Prisma, Blokset and Okken.
- In-built user assistance and warnings on the product for a delight user experience.
- Flexibility in Vertical and horizontal mounting.
- 3 Phase disconnection of Pressure sensitive disconnecter at the end of life which is independent of mechanical assembly for safety and reliability.
- Use of special conductors in stacked design impregnated in resin to ensure better cooling and enhanced life.
- Metallized polypropylene with wave cut and heavy edge technology to handle over current conditions in harsh environments.
- Specially formulated sticky resin to increase the mechanical stability of capacitor elements for higher rating capacitors to ensure better cooling and extended life.
- Designed for high performance in harsh environment to ensure 30% extended life compared to standard capacitors.

Safety

- Self-healing.
- Pressure-sensitive disconnecter on all three phases independent of mechanical assembly.
- Tamper resistant non-accessible in-built discharge resistors.
- Unique Finger-proof New CLAMPTITE terminals to reduce risk of accidental contact and to ensure firm termination (10 to 30 kvar) and maintained tightness.
- Special film resistivity and metallization profile for higher thermal efficiency, lower temperature rise and enhanced life expectancy.

Technology

VarPlus Can capacitors are constructed internally with single-phase capacitor elements. Each capacitor element is manufactured with metallized polypropylene film as the dielectric, having features such as heavy edge, slope metallization and wave-cut profile to ensure increased current handling capacity and reduced temperature rise.

Sticky resin which give good thermal conductivity and mechanical stability allows the capacitor to carry higher overloads.

Stud type terminals are designed for handling higher currents for capacitors.

The unique finger-proof CLAMPTITE termination is fully integrated with discharge resistors, allowing suitable access for tightening and ensuring cable termination without any loose connections.

For lower ratings, double fast-on terminals with wires are provided.

Benefits

- Save panel space due to its compact design and range.
- High Performance & Long life.
- High over current handling.
- Unique disconnection system and in-built discharge device.
- Flexibility in installation - upright and horizontal.

VarPlus Can 04 copy eps



VarPlus Can 02 copy eps



Technical specifications

General characteristics

Standards	IEC 60831-1/2	
Voltage range	230 to 830 V	
Frequency	50 / 60 Hz	
Power range	1 to 57.1 kvar	
Losses (dielectric)	< 0.2 W/kvar	
Losses (total)	< 0.5 W/kvar	
Capacitance tolerance	-5%, +10%	
Voltage test	Between terminals	2.15 x U _N (AC), 10 s
	Between terminal & container	≤ 525 V: 3 kV (AC), 10 s or 3.66 kV (AC), 2 s > 525 V: 3.66 kV (AC), 10 s or 4.4 kV (AC), 2 s
	Impulse voltage	≤ 690 V: 8 kV > 690 V: 12 kV
Discharge resistor	Fitted, standard discharge time 60 s	

Working conditions

Ambient temperature	-25 / 55 °C (Class D)
Humidity	95 %
Altitude	2,000 m above sea level
Overtoltage	1.1 x U _N 8 h in every 24 h
Overcurrent	Up to 1.8 x I _N
Peak inrush current	250 x I _N
Switching operations (max.)	Up to 7,000 switching operations per year
Mean Life expectancy	Up to 130,000 hrs
Harmonic content withstand	N _{LL} ≤ 20 %

Installation characteristics

Mounting position	Indoor, upright & horizontal
Fastening	Threaded M12 stud at the bottom
Earthing	
Terminals	CLAMPTITE - three-way terminal with electric shock protection (finger-proof) and, double fast-on terminal in lower kvar and stud type for higher power ratings

Safety features

Safety	Self-healing + Pressure-sensitive disconnecter + Discharge device
Protection	IP20 (for fast-on and clamptite terminal)

Construction

Casing	Extruded Aluminium Can
Dielectric	Metallized polypropylene film with Zn/Al alloy. Special resistivity & profile, special edge (wave-cut)
Impregnation	Non-PCB, polyurethane sticky resin (Dry)

⚠ WARNING

HAZARD OF ELECTRICAL SHOCK

Wait 5 minutes after isolating supply before handling

 Failure to follow these instructions can result in injury or equipment damage

A robust, safe, reliable and high-performance solution for power factor correction in standard operating conditions.



VarPlus Box

Operating conditions

- Optimum solution for stand alone PF compensation
- For networks with significant non-linear loads ($N_{LL} \leq 20\%$).
- Ambient operating temperature up to 55°C.
- Maximum number of switching operations up to 7,000/year.
- Long life expectancy up to 130,000 hours.

VarPlus Box – Answer for high performance with robustness

Robustness

- Double metallic protection.
- Mechanically well suited for “stand-alone” installations.

Safety

- Its unique safety feature electrically disconnects the capacitors safely at the end of their useful life.
- The disconnectors are installed on each phase, which makes the capacitors very safe, in addition to the protective steel enclosure.
- Use of Aluminum cells inside the steel enclosure eliminates the risk of any fire hazards unlike with plastic cells.

High performance

- Heavy edge metallization to ensure high inrush current capabilities and high current handling.
- Special resistivity and profile metallization for better self-healing & enhanced life.

Technology

Constructed internally with single phase or three phase capacitor elements.

The design is specially adapted for mechanical stability. The enclosures of the units are designed to ensure that the capacitors operate reliably in hot and humid tropical conditions.

Special attention is paid to equalization of temperatures within the capacitor enclosures since this gives better overall performance.

Benefits

- Robustness with double metal protection (Aluminum cans inside steel box).
- Suitable for individual compensation with stand alone installation.
- Direct connection to a machine, in harsh environmental conditions.
- Dual safety .
- Pressure Sensitive Disconnector(PSD) in aluminum cans with metal enclosure.

Technical specifications

General characteristics

Standards	IEC 60831-1/2	
Voltage range	400 to 830 V	
Frequency	50 / 60 Hz	
Power range	5 to 60 kvar	
Losses (dielectric)	< 0.2 W/kvar	
Losses (total)	< 0.5 W/kvar	
Capacitance tolerance	-5%, +10%	
Voltage test	Between terminals	2.15 x U _N (AC), 10 s
	Between terminal & container	≤ 525 V: 3 kV (AC), 10 s or 3.66 kV (AC), 2 s > 525 V: 3.66 kV (AC), 10 s or 4.4 kV (AC), 2 s
	Impulse voltage	≤ 690 V: 8 kV > 690 V: 12 kV
Discharge resistor	Fitted, standard discharge time 60 s	

Working conditions

Ambient temperature	-25 / 55 °C (Class D)
Humidity	95 %
Altitude	2,000 m above sea level
Overvoltage	1.1 x U _N , 8h in every 24 h
Overcurrent	Up to 1.8 x I _N
Peak inrush current	250 x I _N
Switching operations (max.)	Up to 7,000 switching operations per year
Mean Life expectancy	Up to 130,000 hrs
Harmonic content withstand	N _{LL} ≤ 20 %

Installation characteristics

Mounting position	Indoor, upright
Fastening	Mounting cleats
Earthing	
Terminals	Bushing terminals designed for large cable termination

Safety features

Safety	Self-healing + Pressure-sensitive disconnecter for each phase + Discharge device
Protection	IP20

Construction

Casing	Sheet steel enclosure
Dielectric	Metallized polypropylene film with Zn/Al alloy, special resistivity & profile.
Impregnation	Non-PCB, polyurethane soft resin.

⚠ WARNING

HAZARD OF ELECTRICAL SHOCK

Wait 5 minutes after isolating supply before handling

 Failure to follow these instructions can result in injury or equipment damage

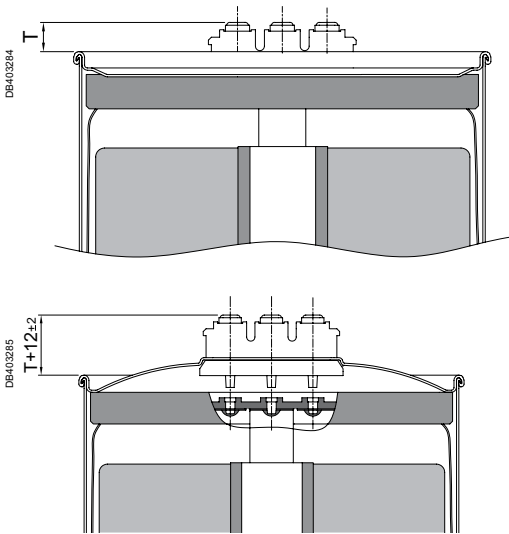

Pressure Sensitive Disconnecter (PSD)

Three phase Pressure Sensitive Disconnecter is provided to disconnect all three phases simultaneously at the end of life of every capacitor. This unique technology ensures the safe disconnection of capacitor at the end of its service life.

Repeated self healing process over a period of time or instantaneous due to faults, generates gases inside the capacitor which will lead the pressure sensitive disconnecter to operate. Pressure can lead to vertical expansion of pressure sensitive disconnecter by bending the lid outwards. Disconnecting joints break at intended spots to ensure safe disconnection of all three phases.

Once the PSD operates capacitors will be disconnected permanently.

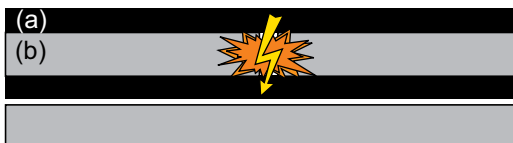

Figure 1 - (a) Metal layer - (b) Polypropylene film

Self Healing

An electric breakdown is possible in the capacitor films due to electric or mechanical over stress. Due to this a small area of metallization will get evaporated and the capacitor will continue to be in service. Continuation of these phenomena will reduce the capacitance value as well as life of the capacitor over a period of time.



Figure 2

Self-healing is a process by which the capacitor restores itself in the event of a fault in the dielectric which can happen during high overloads, voltage transients, etc.

When insulation breaks down, a short duration arc is formed (figure 1).

The intense heat generated by this arc causes the metallization in the vicinity of the arc to vaporise (figure 2).

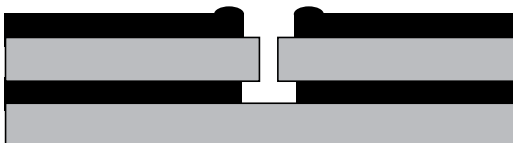

Figure 3

Simultaneously it re-insulates the electrodes and maintains the operation and integrity of the capacitor (figure 3).

Discharge Resistors

A charged Capacitor must be discharged before re-switching, to prevent premature failure. Built-in discharge resistors are used for discharging the capacitor within one minute.

⚠ WARNING

HAZARD OF ELECTRICAL SHOCK

Wait 5 minutes after isolating supply before handling

 Failure to follow these instructions can result in injury or equipment damage

Reactors have to be associated to capacitor banks for Power Factor Correction in systems with significant non-linear loads, generating harmonics.

Capacitors and reactors are configured in a series resonant circuit, tuned so that the series resonant frequency is below the lowest harmonic frequency present in the system. For this reason, this configuration is usually called “Detuned Capacitor Bank”, and the reactors referred as “Detuned Reactors”.

The use of detuned reactors thus prevents harmonic resonance problems, avoids the risk of overloading the capacitors and contributes to reducing voltage harmonic distortion in the network. The tuning frequency can be expressed by the relative impedance of the reactor (in %), or by the tuning order, or directly in Hz.

The most common values of relative impedance are 5.7, 7 and 14%. (14% is used with high level of 3rd harmonic voltages).

Relative impedance (%)	Tuning order	Tuning frequency @50Hz (Hz)	Tuning frequency @60Hz (Hz)
5.7	4.2	210	250
7	3.8	190	230
14	2.7	135	160

⚠ WARNING

HAZARD OF ELECTRICAL SHOCK/EQUIPMENT DAMAGE

 Detuned reactors are designed/verified and Validated to work with a suitable rated capacitors for conforming performance as per specification.

Suitable rated Capacitors designated to work with reactors for suitable application.

Refer the application table and associated combination selection chart in this document to ensure the right selection of capacitor and detuned reactor for a given output power and a tuning factor.

Follow Preventive maintenance of the capacitor bank to avoid usage of de-rated capacitor

Capacitors has to be replaced if de-rated more than specified values in the catalogue

Avoid wrong selection of the combination or derating of capacitor to deliver unintended output.

Wait 5 minutes after isolating supply before handling.

Always use a properly rated voltage sensing device to confirm power is off.

Carefully Inspect the interior for tools left behind before replacing covers and closing doors.

Failure to follow these instructions can result in injury or equipment damage

The selection of the tuning frequency of the reactor capacitor depends on multiple factors:

- Presence of zero-sequence harmonics (3, 9, ...),
- Need for reduction of the harmonic distortion level,
- Optimization of the capacitor and reactor components.
- Frequency of ripple control system if any.

To prevent disturbances of the remote control installation, the tuning frequency is to be selected at a lower value than the ripple control frequency. In a detuned filter application, the voltage across the capacitors is higher than the nominal system voltage. Then, capacitors must be designed to withstand higher voltages.

Depending on the selected tuning frequency, part of the harmonic currents is absorbed by the detuned capacitor bank. Then, capacitors must be designed to withstand higher currents, combining fundamental and harmonic currents.

Working limits

In order to avoid any overload of detuned reactors and capacitors, maximum values of voltage distortion have to be respected. Harmonic voltages and THD_u have to be measured at the transformer secondary, with the capacitors connected. The current through the capacitors has to be compared to the rated value.

I_{mp}/I_N is the ratio of the maximum permissible current to the rated current of the capacitor.

The maximum permissible current limit values are given in the page no. 26.

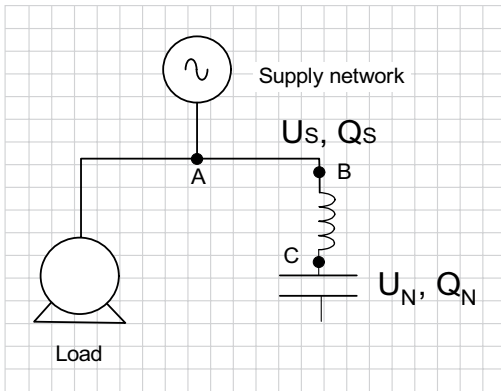

Refer to the picture above and consider the following:

- U_s : system voltage (V),
- Q_s : requested reactive power (kvar)
- U_N : capacitor rated voltage (V)
- Q_N : capacitor rated power (kvar)

User Tip:

While selecting the capacitor rated voltage more stringent values **should** be adopted on account of network voltage variations, temperature and presence of harmonics.

For an instance, in a 400V network with 14%(2.7) detuned reactor, the minimum rated voltage of the capacitor as per the recommendation is 480V, however users can select 525V rated capacitor considering network conditions. Higher voltage rated capacitors gives better life in comparison with recommended rated voltage.

VarPlus or EasyCan capacitors when used along with detuned reactors have to be selected with a rated voltage higher than network service voltage (U_s).

The recommended rated voltage of capacitors to be used in detuned filter applications with respect to different network service voltage (U_s) and relative impedance is given in the table below. These values ensure a safe operation in the most stringent operating conditions.

Less conservative values may be adopted, but a case by case analysis is necessary.

Capacitor Rated Voltage (U_N) V	Network Service Voltage (U_s) V				
	50Hz		60Hz		
	400	690	400	480	600
Relative Impedance (%)	5.7%				
	7%	480	830	480	575
	14%	480		480	

Example of Capacitor Selection with a Detuned Reactor

Case: For a 400V 50Hz system, It is required to connect a VarPlus Can of 25kvar reactive power with a detuned reactor with 7% relative impedance P (Tuning factor = 3.8).

$Q_s = 25\text{kvar}$,
 $U_s = 400\text{V}$,
 $P = 0.07$

Step 1: Calculation of the capacitor rated voltage

The voltage applied to the capacitor is given by the formula:

$U_c = U_s / (1 - P)$
 $U_c = 400 / (1 - 0.07) = 430.1 \text{ V}$

Minimum rated voltage of capacitor selection = 440V
 Capacitor rated voltage recommended by Schneider Electric after considering safety factors $U_N = 480\text{V}$
 (More stringent values should be adopted on account of network voltage variations / de tuning frequency and temperature)

Step 2: Calculation of capacitor reactive power

1. Reactive power delivered by the capacitor in the capacitor reactor combination at system voltage is(Q_c) is

$Q_c = (1-P) \times Q_s = (1-0.07) \times 25 = 23.25\text{kvar}$

at the network voltage (U_N) the capacitor will deliver 23.25kvar.

2. Rated power of capacitor at rated capacitor voltage (Q_N)

Rated capacitor voltage (U_N) = 480V
 Capacitor delivered power at Network voltage (U_s) = 23.25kvar
 Capacitor power at capacitor rated voltage (Q_N)
 $Q_N = Q_c \times (U_N/U_s)^2 = 23.25 \times (480/400)^2 = 33.5\text{kvar}$

Combination of capacitor with part number **BLRCH339A407B48** and detuned reactor with part number **LVR07250A40T** will give 25kvar at Point B (Refer picture above).

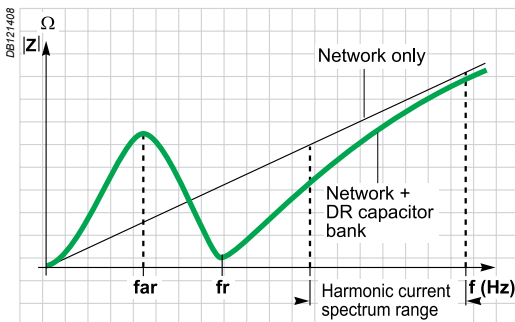
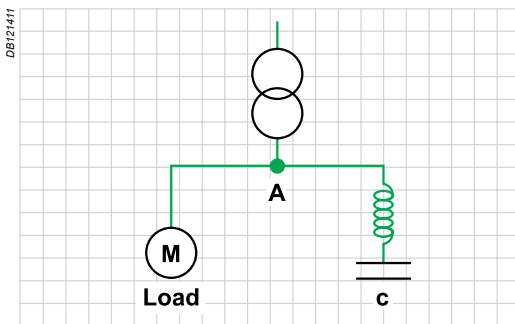
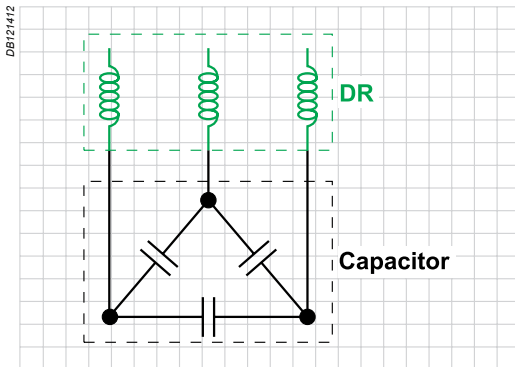

Curve: impedance module at point A

General

The detuned reactors (DR) are designed to protect the capacitors by preventing amplification of the harmonics present on the network. They must be connected in series with the capacitors.

The detuned reactors generate an overvoltage at the capacitor terminals. The rated voltage of capacitors has to be increased accordingly.

Technical data

Choice of tuning: The tuning frequency f_r corresponds to the resonance frequency of the L-C assembly.

$$f_r = \frac{1}{2\pi\sqrt{LC}}$$

We also speak of tuning order n .

For a 50 Hz network:

$$n = \frac{f_r}{50 \text{ Hz}}$$

The tuning frequency chosen must ensure that the harmonic current spectrum range is outside the resonance frequency. It is essential to ensure that no remote control frequencies are disturbed.

If the network is likely to have 3rd harmonics, then the tuning frequency should be 14% (2.7, 135 Hz) because, the capacitors and reactors are configured in a series resonant circuit, tuned so that the series resonant frequency should be the lowest harmonic frequency present in the system. In the absence of 3rd harmonic in the network, 7% (3.8) or 5.7% (4.2) tuning order could be selected. .

The tuning factor (P)

The tuning factor (P) is the ratio of Inductor Impedance to the capacitor Impedance

$$P = \frac{X_L}{X_C} = (2\pi f)^2 LC = (2\pi\sqrt{LC})^2 f^2$$

$$P = \frac{f^2}{f_r^2}$$

$$f_r = \frac{f}{\sqrt{P}}$$

The detuned reactors (DR) are designed to protect the capacitors by preventing amplification of the harmonics present on the network.

PE90154.eps

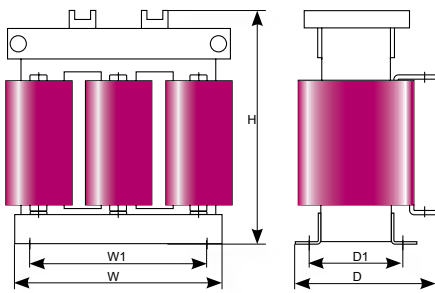

For dimensions and more details, please consult us.

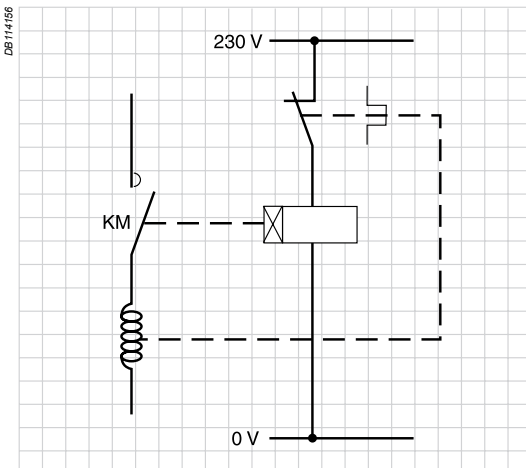

Normally closed dry contact for thermal protection of detuned reactor - In built with detuned reactor.

Operating conditions

- Use: indoor.
- Storage temperature: -40 °C, +60 °C.
- Relative humidity in operation: 20-80 % .
- Operating temperature:
 - altitude: ≤ 1000 m: Min = 0 °C, Max = 55 °C, highest average over 1 year = 40 °C, 24 hours = 50 °C.
 - altitude: ≤ 2000 m: Min = 0 °C, Max = 50°C, highest average over 1 year = 35 °C, 24 hours = 45°C.

Installation guidelines

- Forced ventilation required.
 - Vertical detuned reactor winding for better heat dissipation.
- As the detuned reactor is provided with thermal protection, the normally closed dry contact must be used to disconnect the step in the event of overheating.

Technical specifications

General characteristics

Description	Three-phase, dry, magnetic circuit, impregnated
Applicable Standards	IEC 60076-6
Degree of protection	IP00
Rated voltage	400 to 690 V - 50 Hz 400 to 600 V - 60 Hz Other voltages on request
Inductance tolerance per phase	-5, +5 %
Insulation level	1.1 kV
Continuous overload factor on fundamental current for reactor design	10%
Saturation current	1.8 x I ₁
Dielectric test 50/60 Hz between windings and windings/earth	4 kV, 1 min
Thermal protection	Thermal sensor inside the winding connected to a NO contact of 250 V AC, 2 A

Let's define the fundamental current I₁(A) as the current absorbed by the capacitor and detuned reactor assembly, when a purely sinusoidal voltage is applied, equal to the network service voltage U_S(V).

$$I_1 = Q \text{ (kvar)} / (\sqrt{3} \times U_S)$$

In order to operate safely in real conditions, a detuned reactor must be designed to accept a maximum permanent current (I_{MP}) taking account of harmonic currents and voltage fluctuations. The following table gives the typical percentage of harmonic currents considered for the different tuning orders.

(%)	% of Harmonic currents			
Tuning order / Relative Impedance	i ₃	i ₅	i ₇	i ₁₁
2.7 / 14%	5	15	5	2
3.8 / 7%	3	40	12	5
4.2 / 5.7%	2	63	17	5

Detuned reactor has to be protected from over currents with MCCB. A 1.1 factor is applied in order to allow long-term operation at a supply voltage up to (1.1 x U_S).

$$I_{MP} = 1.1 \times I_1 + I_3 + I_5 + I_7 + I_{11}$$

The maximum permanent current (I_{MP}) as well as the limits of Total voltage harmonics distortion are given in the following table for different tuning orders:

Tuning order	I _{MP} (times I _S)	Max THD _V Limit
2.7 / 14%	1.12	8%
3.8 / 7%	1.2	7%
4.2 / 5.7%	1.3	6%

⚠ WARNING

Force ventilation is mandatory while installing detuned reactors. It is mandatory to connect thermal protection contact to trip the breaker while connecting detuned reactors.

The temperature around the reactor, should be maintained < 55 degrees, to which it is designed (Operating temperature of panel) through proper ventilation.

EasyCan application with reactors

Three Phase Applications

EasyCan capacitors are designed to work in slightly polluted networks with detuned reactors. 480 and 525V range of EasyCan is designed to work with detuned reactors in 400V.

Operating conditions

- For slightly polluted networks.
- Slight voltage disturbances.
- Need of switching frequency up to 5000 /year.

Rated voltage

In a detuned filter application, the voltage across the capacitors is higher than the network service voltage (U_s). Then, capacitors must be designed to withstand higher voltages.

Depending on the selected tuning frequency, part of the harmonic currents are absorbed by the detuned capacitor bank. Then, capacitors must be designed to withstand higher currents, combining fundamental and harmonic currents.

The rated voltage of EasyCan capacitors is given in the table below, for different values of network service voltage and relative impedance.

Capacitor Rated Voltage U_N (V)		Network Service Voltage U_s (V)	
		50 Hz	60 Hz
		400	400
Relative Impedance (%)	5.7	480	480
	7	480	480
	14	480	480

In the following pages, the effective power (kvar) given in the tables is the reactive power provided by the combination of capacitors and reactors.



Detuned reactor

EasyCan

EasyCan + Detuned Reactor + Contactor + MCCB

FE30154_L28.jpg



Network 400 V, 50 Hz Capacitor Voltage 480 V 5.7 % / 7 % Detuned Filter						
Effective Power (kvar)	Q _N at 480 V	Capacitor Ref.	5.7% fr = 215Hz	7% fr = 190Hz	Switching: Contactor Ref.	Protection: Easypact CVS (I _{cu} =36kA) Ref.
			D R Ref	D R Ref.		
6.5	8.8	BLRCS088A106B48 x 1	LVR05065A40T x 1	LVR07065A40T x 1	LC1D12 x 1	LV510330 x 1
12.5	17	BLRCS170A204B48 x 1	LVR05125A40T x 1	LVR07125A40T x 1	LC1D18 x 1	LV510331 x 1
25	33.9	BLRCS339A407B48 x 1	LVR05250A40T x 1	LVR07250A40T x 1	LC1D38 x 1	LV510334 x 1
50	67.9	BLRCS339A407B48 x 2	LVR05500A40T x 1	LVR07500A40T x 1	LC1D95 x 1	LV510337 x 1
100	136	BLRCS339A407B48 x 4	LVR05X00A40T x 1	LVR07X00A40T x 1	LC1F185 x 1	LV525332 x 1

EasyCan03.jpg



Network 400 V, 50 Hz Capacitor Voltage 480 V 14 % Detuned Filter					
Effective Power (kvar)	Q _N at 480 V	Capacitor Ref.	14% fr = 135Hz	Switching: Contactor Ref.	Protection: Easypact CVS (I _{cu} =36kA) Ref.
			D R Ref		
6.5	8.8	BLRCS088A106B48 x 1	LVR14065A40T x 1	LC1D12 x 1	LV510330 x 1
12.5	15.5	BLRCS155A186B48 x 1	LVR14125A40T x 1	LC1D18 x 1	LV510331 x 1
25	31.5	BLRCS315A378B48 x 1	LVR14250A40T x 1	LC1D38 x 1	LV510334 x 1
50	63	BLRCS315A378B48 x 2	LVR14500A40T x 1	LC1D95 x 1	LV510337 x 1
100	126	BLRCS315A378B48 x 4	LVR14X00A40T x 1	LC1F185 x 1	LV525332 x 1

28_PB_107887.jpg



Network 400 V, 50 Hz Capacitor Voltage 525 V 5.7 % / 7 % Detuned Filter						
Effective Power (kvar)	Q _N at 525 V	Capacitor Ref.	5.7% fr = 215Hz	7% fr = 190Hz	Switching: Contactor Ref.	Protection: Easypact CVS (I _{cu} =36kA) Ref.
			D R Ref	D R Ref.		
6.5	10.6	BLRCS106A127B52 x 1	LVR05065A40T x 1	LVR07065A40T x 1	LC1D12 x 1	LV510330 x 1
12.5	20	BLRCS200A240B52 x 1	LVR05125A40T x 1	LVR07125A40T x 1	LC1D18 x 1	LV510331 x 1
25	40	BLRCS200A240B52 x 2	LVR05250A40T x 1	LVR07250A40T x 1	LC1D38 x 1	LV510334 x 1
50	80	BLRCS200A240B52 x 4	LVR05500A40T x 1	LVR07500A40T x 1	LC1D95 x 1	LV510337 x 1
100	160	BLRCS200A240B52 x 8	LVR05X00A40T x 1	LVR07X00A40T x 1	LC1F185 x 1	LV525332 x 1

PB108417-02.jpg



Network 400 V, 50 Hz Capacitor Voltage 525 V 14 % Detuned Filter					
Effective Power (kvar)	Q _N at 525 V	Capacitor Ref.	14% fr = 135Hz	Switching: Contactor Ref.	Protection: Easypact CVS (I _{cu} =36kA) Ref.
			D R Ref.		
6.5	10.6	BLRCS106A127B52 x 1	LVR14065A40T x 1	LC1D12 x 1	LV510330 x 1
12.5	20	BLRCS200A240B52 x 1	LVR14125A40T x 1	LC1D18 x 1	LV510331 x 1
25	40	BLRCS200A240B52 x 2	LVR14250A40T x 1	LC1D38 x 1	LV510334 x 1
50	75	BLRCS250A300B52 x 3	LVR14500A40T x 1	LC1D95 x 1	LV510337 x 1
100	150	BLRCS250A300B52 x 6	LVR14X00A40T x 1	LC1F185 x 1	LV525332 x 1

EasyCan + Detuned Reactor + Contactor + MCCB



Network 400 V, 50 Hz Capacitor Voltage 480 V 5.7 % / 7 % Detuned Filter						
Effective Power (kvar)	Q _N at 480 V	Capacitor Ref.	5.7% fr = 215Hz	7% fr = 190Hz	Switching: Contactor Ref.	Protection: Easypact CVS (I _{cu} =36kA)Ref.
			D R Ref	D R Ref.		
6.5	8.8	BLRCS088A106B48 × 1	LVR05065A40T × 1	LVR07065A40T × 1	LC1D12 × 1	LV510330 × 1
12.5	17	BLRCS170A204B48 × 1	LVR05125A40T × 1	LVR07125A40T × 1	LC1D18 × 1	LV510331 × 1
25	33.9	BLRCS339A407B48 × 1	LVR05250A40T × 1	LVR07250A40T × 1	LC1D38 × 1	LV510334 × 1
50	67.9	BLRCS339A407B48 × 2	LVR05500A40T × 1	LVR07500A40T × 1	LC1D95 × 1	LV510337 × 1
100	136	BLRCS339A407B48 × 4	LVR05X00A40T × 1	LVR07X00A40T × 1	LC1F185 × 1	LV525332 × 1



Network 400 V, 50 Hz Capacitor Voltage 480 V 14 % Detuned Filter						
Effective Power (kvar)	Q _N at 480 V	Capacitor Ref.	14% fr = 135Hz		Switching: Contactor Ref.	Protection: Easypact CVS (I _{cu} =36kA)Ref.
			D R Ref	D R Ref.		
6.5	8.8	BLRCS088A106B48 × 1	LVR14065A40T × 1		LC1D12 × 1	LV510330 × 1
12.5	15.5	BLRCS155A186B48 × 1	LVR14125A40T × 1		LC1D18 × 1	LV510331 × 1
25	31.5	BLRCS315A378B48 × 1	LVR14250A40T × 1		LC1D38 × 1	LV510334 × 1
50	63	BLRCS315A378B48 × 2	LVR14500A40T × 1		LC1D95 × 1	LV510337 × 1
100	126	BLRCS315A378B48 × 4	LVR14X00A40T × 1		LC1F185 × 1	LV525332 × 1



Network 400 V, 50 Hz Capacitor Voltage 525 V 5.7 % / 7 % Detuned Filter						
Effective Power (kvar)	Q _N at 525 V	Capacitor Ref.	5.7% fr = 215Hz	7% fr = 190Hz	Switching: Contactor Ref.	Protection: Easypact CVS (I _{cu} =36kA) Ref.
			D R Ref	D R Ref.		
6.5	10.6	BLRCS106A127B52 × 1	LVR05065A40T × 1	LVR07065A40T × 1	LC1D12 × 1	LV510330 × 1
12.5	20	BLRCS200A240B52 × 1	LVR05125A40T × 1	LVR07125A40T × 1	LC1D18 × 1	LV510331 × 1
25	40	BLRCS200A240B52 × 2	LVR05250A40T × 1	LVR07250A40T × 1	LC1D38 × 1	LV510334 × 1
50	80	BLRCS200A240B52 × 4	LVR05500A40T × 1	LVR07500A40T × 1	LC1D95 × 1	LV510337 × 1
100	160	BLRCS200A240B52 × 8	LVR05X00A40T × 1	LVR07X00A40T × 1	LC1F185 × 1	LV525332 × 1



Network 400 V, 50 Hz Capacitor Voltage 525 V 14 % Detuned Filter						
Effective Power (kvar)	Q _N at 525 V	Capacitor Ref.	14% fr = 135Hz		Switching: Contactor Ref.	Protection: Easypact CVS (I _{cu} =36kA)Ref.
			D R Ref	D R Ref.		
6.5	10.6	BLRCS106A127B52 × 1	LVR14065A40T × 1		LC1D12 × 1	LV510330 × 1
12.5	20	BLRCS200A240B52 × 1	LVR14125A40T × 1		LC1D18 × 1	LV510331 × 1
25	40	BLRCS200A240B52 × 2	LVR14250A40T × 1		LC1D38 × 1	LV510334 × 1
50	75	BLRCS250A300B52 × 3	LVR14500A40T × 1		LC1D95 × 1	LV510337 × 1
100	150	BLRCS250A300B52 × 6	LVR14X00A40T × 1		LC1F185 × 1	LV525332 × 1

Network 400 V, 60 Hz Capacitor Voltage 480 V 5.7 % / 7 % Detuned Filter						
Effective Power (kvar)	Q _N at 480 V	Capacitor Ref.	5.7% fr = 250Hz	7% fr = 230Hz	Switching: Contactor Ref.	Protection: Easypact CVS (I _{cu} =36kA)Ref.
			D R Ref	D R Ref		
12.5	17.3	BLRCS144A173B48 × 1	LVR05125B40T × 1	LVR07125B40T × 1	LC1D18 × 1	LV510331 × 1
25	34.6	BLRCS288A346B48 × 1	LVR05250B40T × 1	LVR07250B40T × 1	LC1D38 × 1	LV510334 × 1
50	69.2	BLRCS288A346B48 × 2	LVR05500B40T × 1	LVR07500B40T × 1	LC1D95 × 1	LV510337 × 1
100	138.4	BLRCS288A346B48 × 4	LVR05X00B40T × 1	LVR07X00B40T × 1	LC1F185 × 1	LV525332 × 1

Network 400 V, 60 Hz Capacitor Voltage 480 V 14 % Detuned Filter						
Effective Power (kvar)	Q _N at 480 V	Capacitor Ref.	14% fr = 160Hz		Switching: Contactor Ref.	Protection: Easypact CVS (I _{cu} =36kA)Ref.
			D R Ref	D R Ref.		
12.5	16.3	BLRCS136A163B48 × 1	LVR14125B40T × 1		LC1D18 × 1	LV510331 × 1
25	31	BLRCS258A310B48 × 1	LVR14250B40T × 1		LC1D38 × 1	LV510334 × 1
50	62	BLRCS258A310B48 × 2	LVR14500B40T × 1		LC1D95 × 1	LV510337 × 1
100	124	BLRCS258A310B48 × 4	LVR14X00B40T × 1		LC1F185 × 1	LV525332 × 1

VarPlus Can application with reactors

3 Phase Applications

VarPlus Can capacitors are designed for applications where higher number of non-linear loads are present. Higher current carrying capacity in VarPlus Can allows the operations in stringent conditions.

Operating conditions

- For networks with a large number of non-linear loads ($N_{LL} < 50\%$).
- Significant voltage disturbances.
- Significant switching frequency up to 7000 /year.

Rated voltage

In a detuned filter application, the voltage across the capacitors is higher than the network service voltage (U_s). Then, capacitors must be designed to withstand higher voltages.

Depending on the selected tuning frequency, part of the harmonic currents are absorbed by the detuned capacitor bank. Then, capacitors must be designed to withstand higher currents, combining fundamental and harmonic currents.

The rated voltage of VarPlus Can capacitors is given in the table below, for different values of network service voltage and relative impedance.

Capacitor Rated Voltage U_N (V)		Network Service Voltage U_s (V)				
		50 Hz		60 Hz		
		400	690	400	480	600
Relative Impedance (%)	5.7	480	830	480	575	690
	7					
	14	480	-	480	-	-

In the following pages, the effective power (kvar) given in the tables is the reactive power provided by the combination of capacitors and reactors.

PEB015k eps



VarPlus Can 04 fcopy eps

Detuned reactor

VarPlus Can

VarPlus Can + Detuned Reactor + Contactor + MCCB

FE015f_L28.eps



Network 400 V, 50 Hz Capacitor Voltage 480 V 5.7 % / 7 % Detuned Filter						
Effective Power (kvar)	Q _N at 480 V	Capacitor Ref.	5.7% fr = 215Hz	7% fr = 190Hz	Switching: Contactor Ref.	Protection: Compact NSX (I _{cu} =36kA) Ref.
			D R Ref.	D R Ref.		
6.5	8.8	BLRCH088A106B48 × 1	LVR05065A40T x 1	LVR07065A40T x 1	LC1D12 × 1	LV429637 × 1
12.5	17	BLRCH170A204B48 × 1	LVR05125A40T x 1	LVR07125A40T x 1	LC1D18 × 1	LV429636 × 1
25	33.9	BLRCH339A407B48 × 1	LVR05250A40T x 1	LVR07250A40T x 1	LC1D38 × 1	LV429633 × 1
50	67.9	BLRCH339A407B48 × 2	LVR05500A40T x 1	LVR07500A40T x 1	LC1D95 × 1	LV429630 × 1
100	136	BLRCH339A407B48 × 4	LVR05X00A40T x 1	LVR07X00A40T x 1	LC1F185 × 1	LV431631 × 1

EasyCm03 copy.eps



Network 400 V, 50 Hz Capacitor Voltage 480 V 14 % Detuned Filter						
Effective Power (kvar)	Q _N at 480 V	Capacitor Ref.	14% fr = 135Hz		Switching: Contactor Ref.	Protection: Compact NSX (I _{cu} =36kA) Ref.
			D R Ref.			
6.5	8.8	BLRCH088A106B48 × 1	LVR14065A40T x 1		LC1D12 × 1	LV429637 × 1
12.5	15.5	BLRCH155A186B48 × 1	LVR14125A40T x 1		LC1D18 × 1	LV429636 × 1
25	31.5	BLRCH315A378B48 × 1	LVR14250A40T x 1		LC1D38 × 1	LV429633 × 1
50	63	BLRCH315A378B48 × 2	LVR14500A40T x 1		LC1D95 × 1	LV429630 × 1
100	126	BLRCH315A378B48 × 4	LVR14X00A40T x 1		LC1F185 × 1	LV431631 × 1

26_P607261.eps



Network 400 V, 50 Hz Capacitor Voltage 525 V 5.7 % / 7 % Detuned Filter						
Effective Power (kvar)	Q _N at 525 V	Capacitor Ref.	5.7% fr = 215Hz	7% fr = 190Hz	Switching: Contactor Ref.	Protection: Compact NSX (I _{cu} =36kA) Ref.
			D R Ref.	D R Ref.		
6.5	10.6	BLRCH106A127B52 × 1	LVR05065A40T x 1	LVR07065A40T x 1	LC1D12 × 1	LV429637 × 1
12.5	20	BLRCH200A240B52 × 1	LVR05125A40T x 1	LVR07125A40T x 1	LC1D18 × 1	LV429636 × 1
25	40	BLRCH400A480B52 × 1	LVR05250A40T x 1	LVR07250A40T x 1	LC1D38 × 1	LV429633 × 1
50	80	BLRCH400A480B52 × 2	LVR05500A40T x 1	LVR07500A40T x 1	LC1D95 × 1	LV429630 × 1
100	160	BLRCH400A480B52 × 4	LVR05X00A40T x 1	LVR07X00A40T x 1	LC1F185 × 1	LV431631 × 1

PE110417.eps



Network 400 V, 50 Hz Capacitor Voltage 525 V 14 % Detuned Filter						
Effective Power (kvar)	Q _N at 525 V	Capacitor Ref.	14% fr = 135Hz		Switching: Contactor Ref.	Protection: Compact NSX (I _{cu} =36kA) Ref.
			D R Ref.			
6.5	10.6	BLRCH106A127B52 × 1	LVR14065A40T x 1		LC1D12 × 1	LV429637 × 1
12.5	18.5	BLRCH185A222B52 × 1	LVR14125A40T x 1		LC1D18 × 1	LV429636 × 1
25	37.7	BLRCH377A452B52 × 1	LVR14250A40T x 1		LC1D38 × 1	LV429633 × 1
50	75	BLRCH377A452B52 × 2	LVR14500A40T x 1		LC1D95 × 1	LV429630 × 1
100	150	BLRCH377A452B52 × 4	LVR14X00A40T x 1		LC1F185 × 1	LV431631 × 1

Network 690 V, 50 Hz Capacitor Voltage 830 V 5.7 % / 7 % Detuned Filter						
Effective Power (kvar)	Q _N at 830 V	Capacitor Ref.	5.7% fr = 215Hz	7% fr = 190Hz	Switching: Contactor Ref.	Protection: Compact NSX (I _{cu} =36kA) Ref.
			D R Ref.	D R Ref.		
12.5	17.1	BLRCH171A205B83 × 1	LVR05125A69T x 1	LVR07125A69T x 1	LC1D12 × 1	LV429637 × 1
25	34.2	BLRCH171A205B83 × 2	LVR05250A69T x 1	LVR07250A69T x 1	LC1D25 × 1	LV429635 × 1
50	68.4	BLRCH171A205B83 × 4	LVR05500A69T x 1	LVR07500A69T x 1	LC1D50 × 1	LV429632 × 1
100	136.8	BLRCH171A205B83 × 8	LVR05X00A69T x 1	LVR07X00A69T x 1	LC1F85 × 1	LV430631 × 1

VarPlus Can + Detuned Reactor + Contactor + MCCB

PEB0154_L28_eps



VarPlusCan020200y_eps



28_09/07201_eps



PEB10417_eps



Network 400 V, 60 Hz Capacitor Voltage 480 V 5.7 % / 7 % Detuned Filter						
Effective Power (kvar)	Q _N at 480 V	Capacitor Ref.	5.7% fr = 250Hz		Switching: Contactor Ref.	Protection: Compact NSX (I _{cu} =36kA) Ref.
			D R Ref.	D R Ref.		
12.5	17.3	BLRCH144A173B48 × 1	LVR05125B40T × 1	LVR07125B40T × 1	LC1D18 × 1	LV429636 × 1
25	34.6	BLRCH288A346B48 × 1	LVR05250B40T × 1	LVR07250B40T × 1	LC1D38 × 1	LV429633 × 1
50	67.9	BLRCH288A346B48 × 2	LVR05500B40T × 1	LVR07500B40T × 1	LC1D95 × 1	LV429630 × 1
100	135.8	BLRCH288A346B48 × 4	LVR05X00B40T × 1	LVR07X00B40T × 1	LC1F180 × 1	LV431631 × 1

Network 400 V, 60 Hz Capacitor Voltage 480 V 14 % Detuned Filter						
Effective Power (kvar)	Q _N at 480 V	Capacitor Ref.	14% fr = 160Hz		Switching: Contactor Ref.	Protection: Compact NSX (I _{cu} =36kA) Ref.
			D R Ref.	D R Ref.		
12.5	16.3	BLRCH136A163B48 × 1	LVR14125B40T × 1		LC1D18 × 1	LV429636 × 1
25	31	BLRCH258A310B48 × 1	LVR14250B40T × 1		LC1D38 × 1	LV429633 × 1
50	62	BLRCH258A310B48 × 2	LVR14500B40T × 1		LC1D95 × 1	LV429630 × 1
100	124	BLRCH258A310B48 × 4	LVR14X00B40T × 1		LC1F185 × 1	LV431631 × 1

Network 480 V, 60 Hz Capacitor Voltage 575 V 5.7 % Detuned Filter						
Effective Power (kvar)	Q _N at 575 V	Capacitor Ref.	5.7% fr = 250Hz		Switching: Contactor Ref.	Protection: Compact NSX (I _{cu} =36kA) Ref.
			D R Ref.	D R Ref.		
12.5	18	BLRCH150A180B57 × 1	LVR05125B48T × 1		LC1D12 × 1	LV429636 × 1
25	35	BLRCH292A350B57 × 1	LVR05250B48T × 1		LC1D32 × 1	LV429633 × 1
50	70	BLRCH292A350B57 × 2	LVR05500B48T × 1		LC1D65 × 1	LV429630 × 1
100	140	BLRCH292A350B57 × 4	LVR05X00B48T × 1		LC1F185 × 1	LV431631 × 1

Network 600 V, 60 Hz Capacitor Voltage 690 V 5.7 % Detuned Filter						
Effective Power (kvar)	Q _N at 690 V	Capacitor Ref.	5.7% fr = 250Hz		Switching: Contactor Ref.	Protection: Compact NSX (I _{cu} =36kA) Ref.
			R Ref.	R Ref.		
12.5	16.5	BLRCH138A165B69 × 1	LVR05125B60T × 1		LC1D12 × 1	LV429636 × 1
25	33.1	BLRCH276A331B69 × 1	LVR05250B60T × 1		LC1D25 × 1	LV429634 × 1
50	66.2	BLRCH276A331B69 × 2	LVR05500B60T × 1		LC1D50 × 1	LV429631 × 1
100	132.4	BLRCH276A331B69 × 4	LVR05X00B60T × 1		LC1F185 × 1	LV430630 × 1

TeSys Capacitor duty contactors

For switching 3-phase capacitor banks, used for power factor correction

Special contactors LC1 D•K are designed for switching 3-phase, single- or multiple-step capacitor banks. They comply with standards IEC 60070 and 60831, NFC 54-100, VDE 0560, UL and CSA.



LC1 DPK12••

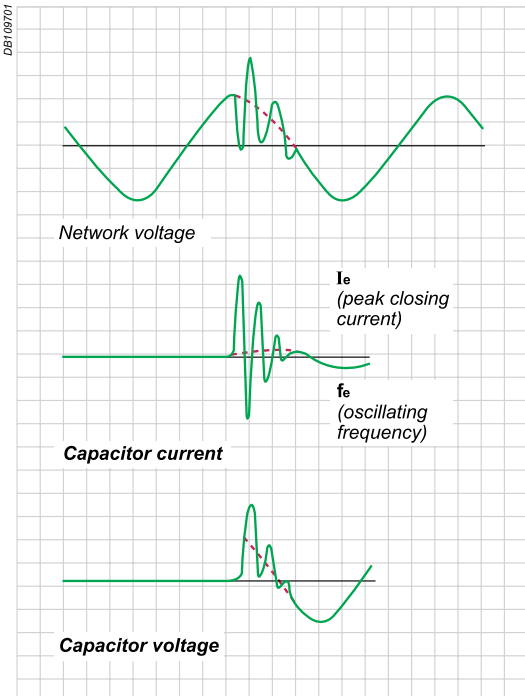

Special contactors

Special contactors **LC1 D•K** are designed for switching 3-phase, single or multiple-step capacitor banks (up to 6 steps). Over 6 steps, it is recommended to use chokes in order to limit the inrush current and thus improve the lifetime of the installation. The contactors are conform to standards IEC 60070 and 60831, UL and CSA.

Contactor applications

Specification

Contactors fitted with a block of early make poles and damping resistors, limiting the value of the current on closing to 60 In max. This current limitation increases the life of all the components of the installation, in particular that of the fuses and capacitors. The patented design of the add-on block (n° 90 119-20) ensures safety and long life of the installation.

Operating conditions

There is no need to use choke inductors for either single or multiple-step capacitor banks. Short-circuit protection must be provided by gl type fuses rated at 1.7...2 In.

Maximum operational power

The power values given in the selection table below are for the following operating conditions:

Prospective peak current at switch-on	LC1 D•K	200 In
Maximum operating rate	LC1 DBK, DCK, DLK, DMK, DPK	240 operating cycles/hour
	LC1 DTK, DWK	100 operating cycles/hour
Electrical durability at nominal load	All contactor ratings	400 V 100 000 operating cycles
		690 V 100 000 operating cycles

Operational power at 50/60 Hz ⁽¹⁾ ($\theta \leq 55^\circ\text{C}$ ⁽²⁾)			Instantaneous auxiliary contacts		Tightening torque on cable end	Basic reference, to be completed by adding the voltage code ⁽³⁾	Weight
220 V	400 V	660 V	N/O	N/C	N.m		kg
kvar	kvar	kvar					
6.7	12.5	18	1	2	1.7	LC1 DBK••	0.430
8.5	16.7	24	1	2	1.7	LC1 DCK••	0.450
10	20	30	1	2	2.5	LC1 DLK••	0.600
15	25	36	1	2	2.5	LC1 DMK••	0.630
20	33.3	48	1	2	5	LC1 DPK••	1.300
25	40	58	1	2	5	LC1 DTK••	1.300
40	60	92	1	2	9	LC1 DWK12••	1.650

Switching of multiple-step capacitor banks (with equal or different power ratings)

The correct contactor for each step is selected from the above table, according to the power rating of the step to be switched.

Example: 50 kvar 3-step capacitor bank. Temperature: 50 °C and U = 400 V or 440 V. One 25 kvar step: contactor LC1 DMK, one 15 kvar step: contactor LC1 DGK, and one 10 kvar step: contactor LC1 DBK.

(1) Operational power of the contactor according to the scheme on the page opposite.

(2) The average temperature over a 24-hour period, in accordance with standards IEC 60070 and 60831 is 45°C.

(3) Standard control circuit voltages (the delivery time is variable, please consult your Regional Sales Office):

Volts	24	48	120	220	230	240	380	400	415	440
50/60 Hz	B7	E7	G7	M7	P7	U7	Q7	V7	N7	R7

TeSys Capacitor duty contactors

For switching 3-phase capacitor banks,
used for power factor correction

All dimensions are in mm

Dimensions

LC1 DFK, DGK

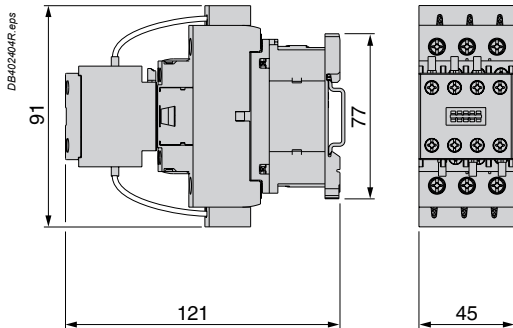

LC1 DLK, DMK

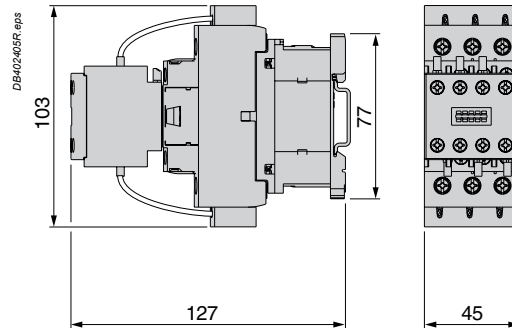

LC1 DPK, DTK

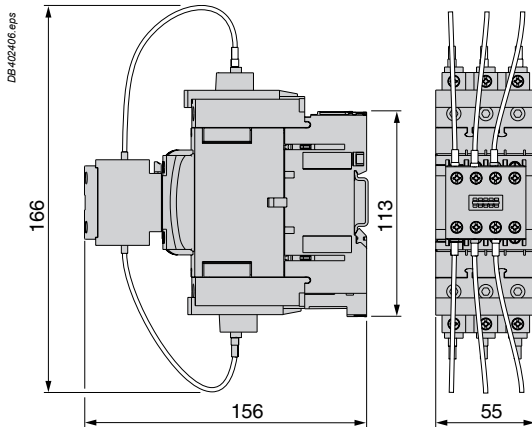

LC1 DWK

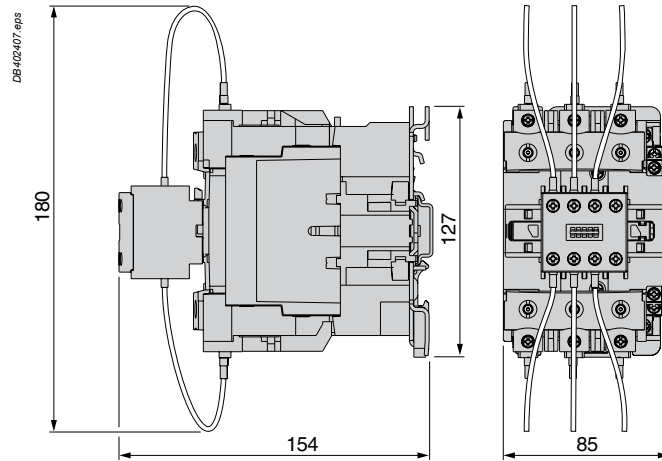

Schemes

LC1 D•K

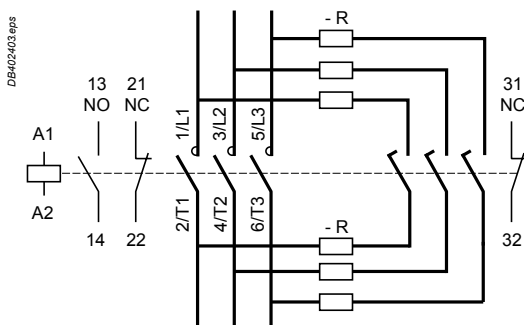

R = Pre-wired resistor connections.

Parallel operation of capacitor and inrush current limiting contactors in APFC panels

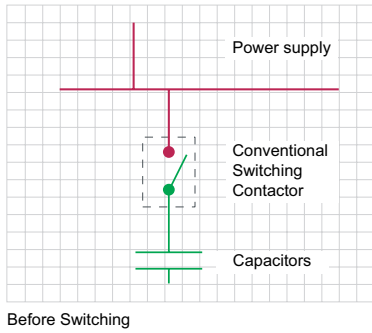

Before Switching

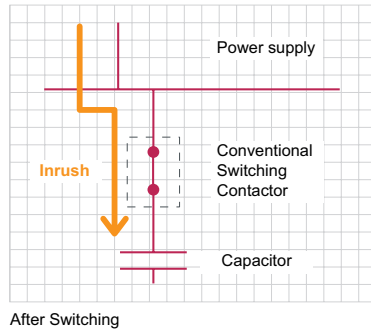

After Switching

Conventional single stage capacitor switching

At capacitor switching while one or more capacitors are connected to the system, the switching capacitor will see a high inrush current. This is due to the current flow from the already connected capacitor(s) (which will act as a source) through the least impedance path set by the switched capacitor along with the current from the main source. This means that when the number of capacitors in parallel increases, the amount of inrush current also increases. Inrush current will damage the capacitor as well as the switching device.

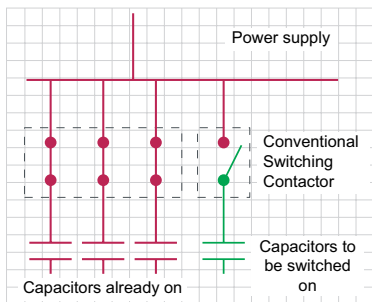

Before Switching

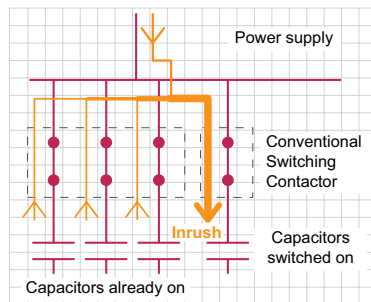

After Switching

Conventional multi stage capacitor switching with normal power contactor

In order to prevent inrush current, it is required to use current limiting devices such as capacitor duty contactors or inductor coil. Pictorial illustration of the conventional switching and switching using a special capacitor duty contactor is shown in the left.

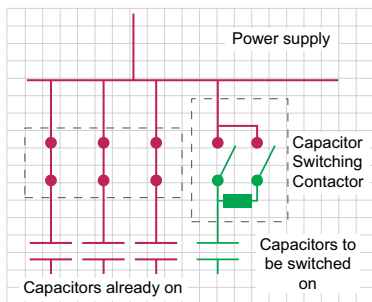

Before Switching

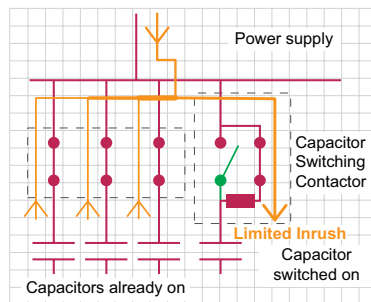

After Switching Stage 1

Multi Stage Capacitor Switching with Capacitor Duty Contactor
Stage 1 - Capacitor is switched through an inrush current limiter

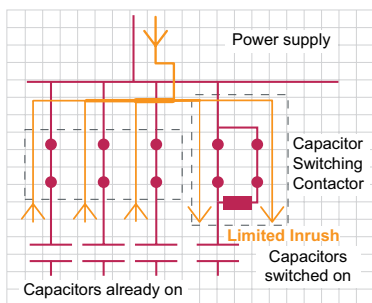

After Switching Stage 2

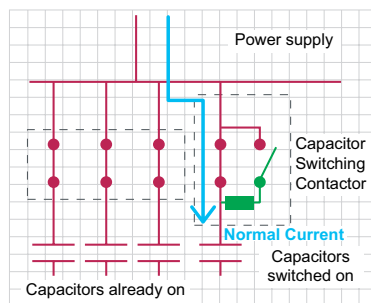

After Switching Stage 3

Stage 2 - Capacitor is switched through Contactor and inrush current limiter
Stage 3 - inrush current limiter is removed from the circuit and Capacitor is completely switched on

User Tip:

User can connect normal power contactor (AC3 duty) to switch the capacitor bank with detuned reactor as detuned reactor acts as a inrush current limiter.

Use switching and protection devices designed for capacitor switching duty.

After switching off a capacitor, a delay of at least 1 minute must be allowed before switching on again to ensure the discharge of individual capacitor step/unit before reconnection. Solid State switching (Thyristor Switches) can be used when fast switching in APFC Panels is needed.

Short Circuit Protection Device

MCCB or MCBs must be used with the capacitor for Short Circuit Protection. This device has to be rated for 1.5 times the rated current of the capacitor. It is recommended to Use Compact NSX/CVS range of MCCBs.

Contactors

Contactors shall be used to switch capacitors in or out of service of each individual step. The contactors shall prevent inrush current to a safe level when the capacitor steps are switched on.

There are two types of contactors used for switching each step:

- Capacitor Duty Contactor
- Power Contactor

Capacitor duty contactors are recommended in APFC equipment to minimize inrush currents experienced during the switching of capacitors. These contactors have special early make contacts with series resistances which dampens the inrush currents.

However, when normal Power contactors are used, and when there are no reactors in series, a suitable inductor coil has to be connected in series with the contactor for limiting the inrush currents.

Contactors will have to be chosen with care, keeping in mind the following factors which can influence their performance:

- Contactor shall be re-strike free and adapted for capacitors
- The rated voltage of the contactor shall be equal to or higher than the maximum network voltage with the power factor correction installation.
- The contactor shall be designed for continuous current (including harmonics) which can pass the power factor correction installation and/or filter at maximum source voltage, maximum frequency and extreme tolerances of the components, especially capacitors and reactors.
- Capacitor duty contactors are rated based on nominal reactive power and Power contactors are rated based on the rated operational current.

It is recommended to use Special Contactors LC1 D.K which are designed for switching 3 phase Single or Multiple step Capacitor Banks.

PF controllers are microprocessor based, which takes real time inputs from the network, calculate the kvar required and switch on /off capacitors. The microprocessor analyzes the current input signal from the load current transformer and the Voltage tapped from the Bus to produce switching commands to control the contactor ON/OFF of the capacitor steps. Intelligent control by PFC controllers ensures an even utilization of capacitor steps, minimized number of switching operations and optimized life cycle.

Feasibility for Four quadrant operation for sensing the energy flow direction becomes necessary for certain applications based on system conditions.

The controller placed inside the panel shall have the reliability to withstand the operating temperature of at least 50 °C or more.

C/k setting:

C/k value is used in the setting of old generation Power Factor Controllers, however it is found rarely to be used in panels now.

C/k value is a threshold value for switching On/Off the capacitor steps by the controller. C/k is the value obtained by dividing first step capacitor power “Q” to the current transformer ratio”K”. This setting shall be automatic or can be set manually.

The main features of the PF controller must include the following:

- Automatic C/k- value setting, Connection of different capacitor steps.
- Automatic detection and usage of optimum capacitor steps.
- Current measuring 10mA-5A, suitable for connecting CT x/1A and x/5A.
- Programmable capacitor switching delay
- Indication for over current
- Indication for low power factor
- Fan contact

Modern day APFC controllers provide various additional functions like electrical data logging, self diagnostics and system health features and are capable of communication using standard protocols. Additional features can be chosen based on specific requirements of end user which are as follows:

- Four Quadrant operation
- Automatic phase reversal correction
- Various automatic trip conditions can be programmed – over current, over voltage
- Single phase measurement
- Various metering parameters like V, I, THD-V, Hz, kvar, temp, PF etc.,

VarPlus Logic has all what you need for the simple and efficient operation of your automatic power factor correction equipment to maintain your power factor. It is a simple and intelligent relay which measure, monitor and controls the reactive energy. Easy commissioning, step size detection and monitoring makes it different from others in the market.

DB417842 Presentation.eps



VarPlus Logic VL6, VL12

User Tip:

Did you know?

VarPlus Logic is integrated in Schneider Electric Gateways Com'X 200 & Com'X 510 with auto device detect

- -You can view dedicated VarPlus Logic Web page with present and stored parameters through the Com'X 510.
- - VarPlus Logic is integrated to the PME/Power Quality Adviser Softwares of Schneider Electric

Capacitor bank step monitoring

- Monitoring of all the connected capacitor steps.
- Real time power in "kvar" for the connected steps .
- Remaining step capacity per step as a % of the original power since installation.
- Derating since installation.
- Number of switching operations of every connected step.

System Measurement and monitoring

- THD(u) and THD(u) Spectrum 3rd to 19th – Measurement, Display and Alarm.
- Measurement of DQ – "kvar" required to achieve target cos phi.
- Present cabinet temperature and maximum recorded temperature.
- System parameters – Voltage, Current, Active, reactive and apparent power.
- Large LCD display to monitor real step status and other parameters.

Easy Commissioning

- Automatic Initialization and automatic step detection to do a auto commissioning.
- Automatic wiring correction - voltage and current input wiring correction.
- 1A or 5A CT secondary compatible.

Flexibility to the panel builder and retrofitting

- No step sequence restriction like in the traditional relays.
- Any step sequences with auto detect. No programming needed.
- Easy to retrofit the faulty capacitor with different power.
- Quick and simple mounting and wiring.
- Connect to the digitized Schneider solutions through RS485 communication in Modbus protocol.
- Seamless connection to the Schneider software and gateways.

Do more with VarPlus Logic

- Programmable alarms with last 5 alarms log.
- Suitable for medium voltage applications.
- Suitable for 4 quadrant operations.
- Dual cos phi control through digital inputs or export power detection.
- Dedicated alarm and fan control relays.
- Advance expert programming Menu to configure the controller the way you need.
- New control algorithm designed to reduce the number of switching operations and quickly attain the targeted power factor.

Alarms

- Faulty Step
- Configurable alarm for step derating
- THDu Limit alarm.
- Temperature alarm
- Self correction by switching off the steps at the event of THDu alarm, temperature alarm and overload limit alarm.
- Under compensation alarm
- Under/Over Voltage Alarm
- Low/High Current Alarm
- Overload limit alarm
- Hunting alarm
- Maximum operational limits - Time and number of switching

Range

Type	Number of step output contacts	Part number
VL6	06	VPL06N
VL12	12	VPL12N

General characteristics

Voltage and current input

Direct supply voltage	90 – 550 V, 1ph, 50/60 Hz
	VA Burden: 6 VA
	300 V LN / 519 V LL CAT III or 550 V CAT II
Type of input connection	Phase to phase or phase to neutral
Protection against voltage dips	Automatic disconnection of steps for dips > 15 ms (protection of capacitor)
CT secondary	1A or 5A compatible
CT primary range	Up to 9600 A
Current	15 mA – 6 A, 1PH,
	VA Burden : < 1 VA
Connection terminals	Screw type, pluggable. Section: 0.2 – 2.5 mm ² (0.2 – 1 mm ² for Modbus and digital inputs)

Power factor settings & algorithm selection

Regulation setting - Programmable	From Cos Phi 0.7c to 0.7i
Reconnection time -Programmable	From 1 to 6500 s
Response time -Programmable	From 1 to 6500 s
Possibility of dual cos Phi target	Yes, Through Digital Input or if export power detected
Program algorithm	AUTOMATIC (best fit) - Default
	LIFO
	PROGRESSIVE
Import export application compatibility	4- Quadrant operation for generator application

Program intelligence

Automatic Initialization and Automatic bank detection	Yes
Detection and display of power, number of switching & derating of all connected steps	Yes
Capacitor bank step sequence	Any sequence. No restriction/limitation on sequence

Dimensions

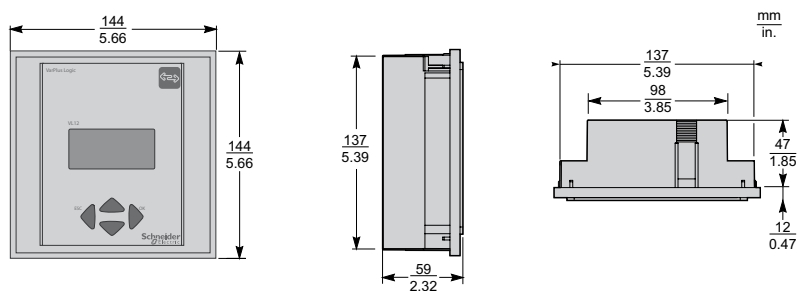

Mounting

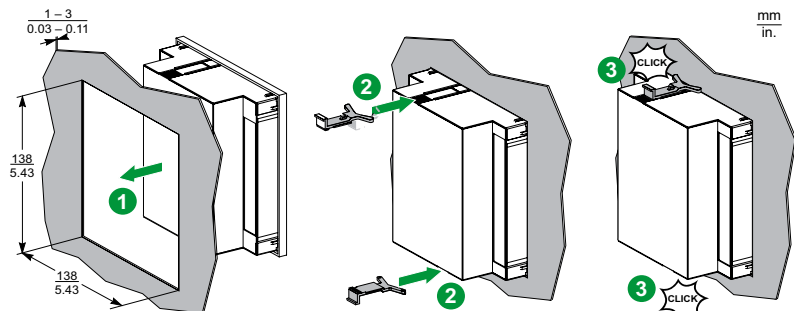

Phase-to-Neutral with VTs (3PH4W)

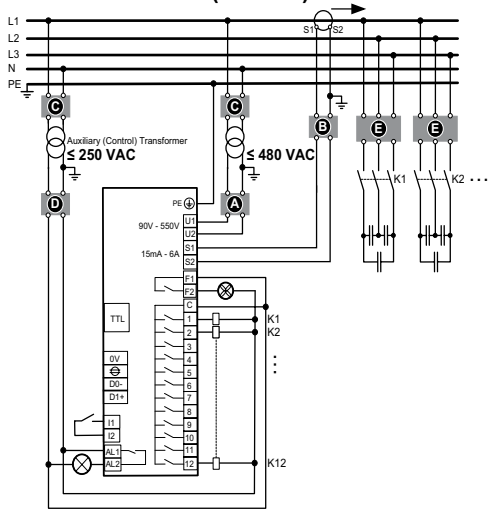

Phase-to-Phase with VTs (3PH3W)

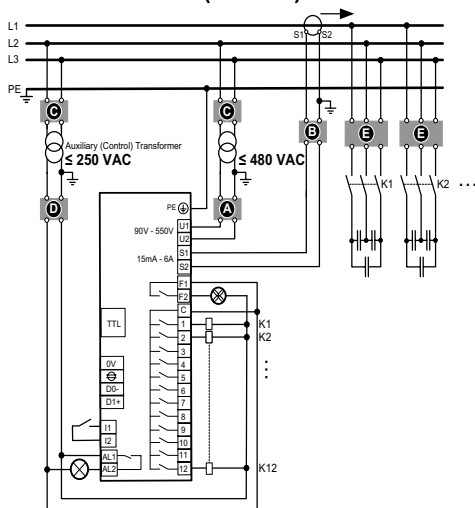

- A** Upstream protection
Voltage input: 2A certified circuit breakers or fuses
- B** Shorting block for CT
- C** VT primary fuses and disconnect switch
- D** Output relays: 10 A (max.) certified circuit breakers or fuses (Applicable for applications with voltage transformers only).
- E** Capacitor primary fuses or CB's

General characteristics

Alarm and control

Control outputs (step output)	VL6: 6 relays VL12: 12 relays (NO contact) 250 V LN or LL (CAT III) DC Rating : 48 V DC / 1 A AC Rating : 250 V AC / 5 A Common root: 10 A max.
Dedicated fan control relay	Yes. Normal open contact (NO) 48 V DC / 1 A, 250 V AC / 5 A
Alarm contact	The relay contact is open when the controller is energized with no alarm and will close in the event of an alarm. The relay is a NC (Normally Close) when the controller is not energized. Rating : 48 V DC / 1 A, 250 V AC / 5 A
Digital Input for Cos phi2 target	Dry contact (internal supply 5 V, 10 mA)
Modbus RS-485 serial port (RTU)	Line polarization / termination, not included
Communication protocol	Modbus
Interface TTL	Service port. Only for internal use
Internal Temperature probe	Yes

Display and measurement

Display	LCD graphic 56 x 25 (Backlit)
Alarms log	5 last alarms
Voltage Harmonic Distortion measurement	THDu ; Individual odd harmonics distortion from H3 to H19
Measurement displayed and accuracy	Voltage, Current & Frequency: ±1 % Energy measurements, Cos Phi, THD(u): ±2 % Individual Voltage harmonics (H3 to H19): ±3 % Temperature measurement : ±3 °C

Testing standards and conformities

Standards	IEC 61010-1 IEC 61000 6-2 IEC 61000 6-4: level B IEC 61326-1 UL 61010
Conformity and listing	Conformity and listing CE, NRTL, c NRTL, EAC

Mechanical specifications

Case	Front: Instrument case plastic RAL 7016 Rear: Metal
Degree of Protection	Front: IP41, (IP54 by using a gasket) Rear: IP20
Weight	0.6 kg
Size	144 x 144 x 58 mm (H x W x D)
Panel Cutout	138 x 138 (+0.5) mm, thickness 1 – 3 mm
Panel Mounting	Flush mounting

Storage condition

Temperature for operation	-20 °C +60 °C
Storage	-40 °C +85 °C
Humidity	0 % - 95 %, without condensation for operation and storage
Maximum pollution degree	2
Maximum altitude	≤ 2000m

Did you know:

It is very common practice with panel builders that they prefer to use 1:1:1:..... step sequence to obtain better electrical stepping sequence.

Often users doesn't know that the same electrical steps can be obtained by less number of mechanical steps. Hence improving user's cost effectiveness.

Use of our intelligent relay VarPlus logic not only optimizes the switching sequence but also it allows you to select any switching sequence user would like to adapt to improve your cost effectiveness.

See the example illustrated in page no. 36.

The VarPlus logic power factor controllers continually measure the reactive power of the system and it's intelligent algorithm helps to optimize the switching of the available capacitor steps in the PFC bank. The real-time reactive energy available with every connected capacitor step is continuously assessed by the VarPlus logic controller.

VarPlus logic controllers doesn't limit the user to restrict the step sequence in the PFC bank design. Hence user can adapt any optimized sequence to get operational efficiency.

- By optimizing the step sequence user can reduce
- the number of power factor correction modules
 - workmanship for panel assembly

Optimizing the control in this way generates considerable financial benefits.

Explanations

Q1 = Power of the first step

Q2 = Power of the second step

Qn = Power of the nth step (maximum 12)

Examples:

- 1.1.1.1.1.1: Q2 = Q1, Q3 = Q1, ..., Qn = Q1
- 1.1.2.2.2.2: Q2 = Q1, Q3 = 2Q1, Q4 = 2Q1, ..., Qn = 2Q1
- 1.2.3.4.4.4: Q2 = 2Q1, Q3 = 3Q1, Q4= 4Q1, ..., Qn = 4Q1
- 1.2.4.8.8.8: Q2 = 2Q1, Q3 = 4Q1, Q4= 8 Q1, ..., Qn = 8 Q1

Calculating the number of electrical steps depends on:

- the number of controller outputs used (e.g. 7)
- the chosen combination, according to the power of the various steps (e.g. 1.2.2.2).

Combinations	Number of controller outputs used											
	1	2	3	4	5	6	7	8	9	10	11	12
1.1.1.1.1.1...	1	2	3	4	5	6	7	8	9	10	11	12
1.1.2.2.2.2...	1	2	4	6	8	10	12	14	16	18	20	22
1.2.2.2.2.2...	1	3	5	7	9	11	13	15	17	19	21	23
1.1.2.3.3.3...	1	2	4	7	10	13	16	19	22	25	28	31
1.2.3.3.3.3...	1	3	6	9	12	15	18	21	24	27	30	33
1.1.2.4.4.4...	1	2	4	8	12	16	20	24	28	32	36	40
1.2.3.4.4.4...	1	3	6	10	14	18	22	26	30	34	38	42
1.2.4.4.4.4...	1	3	7	11	15	19	23	27	31	35	39	43
1.2.3.6.6.6...	1	3	6	12	18	24	30	36	42	48	54	60
1.2.4.8.8.8...	1	3	7	15	23	31	39	47	55	63	71	79

User Tip:

Optimizing the step sizes in the APFC panel can reduce watt loss in the panel and you can save energy.

Practical Example:

Consider an APFC System of 250 kvar

Solution 1: Electrical control 10 x 25 kvar

25 + 25 + 25 + 25 + 25 + 25 + 25 + 25 + 25 + 25 ;
sequence : 1.1.1.1.1.1
10 physical steps
10 contactors – Refer Contactor Selection
12-step controller – (Varlogic – NR12) Refer PFC relays-
Varlogic Selection
Capacitors- VarPlusCan – 10 x 25kvar

Conclusion

High Labor, high cost: non-optimised solution.
Possible Power levels (kvar) : 25,50,75,100,125,150,175, 200,
225, 250

Solution 2: Electrical control 10 x 25 kvar

25 + 50 + 75 +100 = 10 x 25 kvar electrical;
sequence: 1.2.3.4:4
4 physical steps allowing for 10 different power levels
4 contactors (refer contactor selection)
6-step controller (Varlogic NR6 - refer PFC relays- Varlogic
selection)
Capacitors - VarPlusCan - 2 x 25kvar + 2 x 50kvar + 1 x 100kvar

Conclusion

Optimised Solution.
Optimisation of compensation cubicle - Possible power levels
(kvar)
The symbol “•” shows the physical step is On for obtaining the
Possible power levels.

Possible power levels (kvar)	Physical Steps			
	25	50	75	100
25	•			
50		•		
75			•	
100				•
125	•			•
150		•		•
175			•	•
200	•		•	•
225		•	•	•
250	•	•	•	•

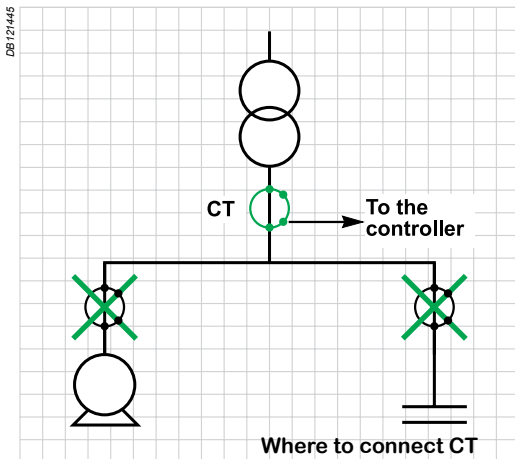

Current transformer (CT) is used in APFC panels for measurement purposes. It steps down load current to a low value (5A) output. The VA rating of CT shall be 5VA or 10VA as the maximum.

The following aspects shall be considered while selecting CTs:

- Resin Cast CTs or Moulded case CTs are sealed units and have better life than the ordinary tape insulated CTs. Moulded case CTs are usually preferred for lower current ratings and resin cast for higher ratings.
- Primary current of the CT has to be selected based on the distribution equipment current rating.
- Ammeter is the only load and considering short distance of wires, 5 to 10VA is selected as a maximum burden.
- It is recommended to use Class 1 CTs for Commercial measurements

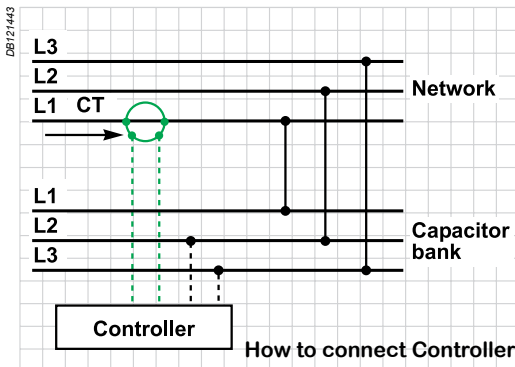

Current Transformer- Installation recommendations

- current transformer must be installed upstream of the installation to be compensated
- the controller voltage should be set between L2 and L3 and the CT to phase L1
- the capacitor bank wiring diagram should be designed to ensure that the time required to discharge the capacitors is observed (minimum 1 minute), for example in the event of a loss of contactor auxiliary voltage
- if the installation comprises two or more supply transformers, a summing CT that will take all the energy consumed by the installation into account must be provided. The ratio to be used to calculate the C/k is the sum of the ratios of the various measuring CTs
- if the installation includes a generator set, a contact will disconnect the capacitor bank in the event of generator set operation. The best method in this case is to use it to cut off the supply to the controller

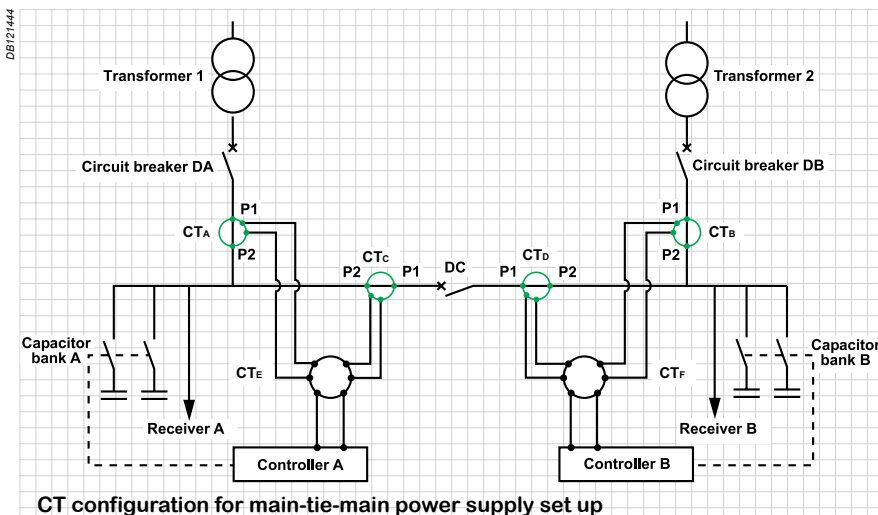
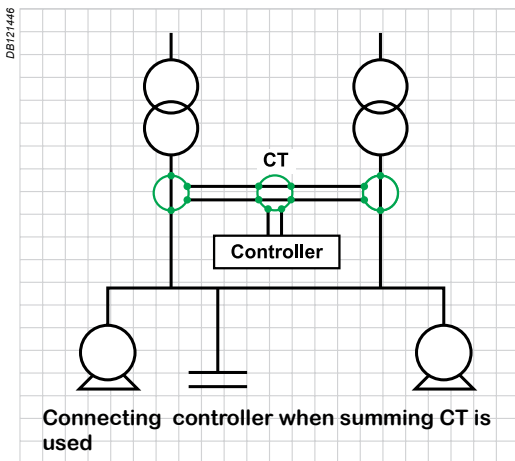

Protection Devices in Automatic Power Factor Correction (APFC) capacitor bank

The following are the protection schemes provided for APFC panels:

Over voltage

In the event of an over voltage, electrical stress on the capacitor dielectric and the current drawn by the capacitors will increase. The APFC equipment must be switched off in the event of over voltage with suitable over voltage relay.

Under voltage

In the event of under voltage, electrical stress on the capacitor dielectric and the current drawn by the capacitors will decrease. This condition is not harmful. But protection is provided based on customer request to protect system from under voltage.

Over Current

Over current condition is very harmful to all current carrying components. All the switch gears are selected on a highest maximum current carrying capacity. However suitable over current relays with alarm can be used for over current protection.

Short circuit protection

At the incomer level or at the upstream capacitor bank feeder short circuit protection is provided by devices such as MCCB, ACB. At the step protection level, only MCB, MCCB has to be used.

Thermal Overload

It is taken care by thermal overload relay. The APFC controller must be tripped in cases where internal ambient temperature exceeds the limits. Reactors are also provided with thermal switches, to trip in the event of temperature increase.

Earthing

Two earthing points shall be provided in the APFC panel for connecting to the earth bus. This will ensure the overall safety of operating personnel and equipment protection in case of earth faults.

Earth Leakage Relay

It has to be connected at power incoming side of the panel, Earth leakage relay is provided to safeguard the operator by tripping the incomer.

Timers

Capacitors require a minimum discharge time of approximately 60 seconds after they are switched off before they can be switched on again. This is to be set in the APFC controller. Capacitors are provided with discharge resistors.

Over Temperature trip mechanism

Temperatures sensors (two thermostats) to be connected

- for operating the fans/industrial air conditioners above 35°C and
- to disconnect main incomer of APFC if the temperature exceeds 55°C inside the panel.

Main incomer is used to disconnect the APFC system in case of short circuit, over load and earth fault. The rating of the incomer switchgear will vary depending on rating of the APFC equipment and the required fault current handling capacity. MCCB or ACB can be used as incomer switchgear depending on the current rating of the APFC equipment and the required fault level.

Outgoing protection is provided to protect the individual capacitor step in the APFC equipment. The outgoing protection may be MCB and MCCB depending on the rating of the individual capacitor steps, required fault level & customer requirement too.

- Factor of 1.5 for over loads

The factor of 1.5 has derived by taking into account the combined effects of harmonics, Over Voltage and capacitance tolerance as per standard IEC 60831.

$1.5 = (1.3 \times 1.15 = 1.495) \sim 1.5$ where

1.3 - Factor of maximum permissible current of capacitors at rated sinusoidal voltage and rated frequency excluding transients.

1.15- Capacitance tolerance.

As per IEC 61921, capacitor current should not be allowed to exceed the above value of 1.5 times hence there is no possibility of increasing the factor. There is no need for reducing the factor since the factors 1.3 and 1.15 are applicable to all types of capacitors.

User Tip:

Other than selecting the rating of the circuit breaker, it is essential to protect the capacitor bank by selecting proper thermal magnetic release setting to allow proper overload protection.

Therefore the safety factor of $(1.5 \times I_n)$ is used for selecting all switchgear.

Thermal and Magnetic setting of a Circuit breaker

The rating must be chosen to allow the thermal protection to be set to:

- $1.5 I_n$ for EasyCan/VarPlus Capacitors
- $1.31 \times I_n$ for EasyCan/VarPlus with 5.6% Detuned Reactor (Tuning Factor 4.3)
- $1.19 \times I_n$ for EasyCan/VarPlus with 7% Detuned Reactor (Tuning Factor 3.8)
- $1.12 \times I_n$ for EasyCan/VarPlus with 14% Detuned Reactor (Tuning Factor 2.7)

Note: Restrictions in Thermal settings of system with Detuned reactors are due to limitation of I_{MP} (Maximum Permissible current) of the Detuned reactor.

Example 1:
150kvar/400v – 50Hz Capacitor

$$U_s = 400V; Q_s = 150kvar$$

$$U_N = 400V; Q_N = 150kvar$$

$$I_s = 150000 / (400\sqrt{3}) = 216A$$

$$\text{Circuit Breaker Rating} = 216 \times 1.5 = 324A$$

Select a 400A Circuit Breaker.

$$\text{Circuit Breaker thermal setting} = 216 \times 1.5 = 324$$

Conclusion:- Select a Circuit Breaker of 400A with

Thermal Setting at 324A and

Magnetic Setting (Short Circuit) at 3240A

Example 2:

20kvar/400v – 50Hz Harmonic Range with 7% Detuned Reactor

$$U_s = 400V; Q_s = 20kvar$$

$$U_N = 440V; Q_N = 22.51kvar$$

Refer: Selection of capacitor with detuned reactor

$$I_n = 22510 / (440\sqrt{3}) = 29.9A$$

$$\text{Circuit Breaker Rating} = 29.9 \times 1.5 = 45A$$

$$\text{Circuit Breaker thermal setting} = 29.9 \times 1.19 = 35.6A$$

Conclusion:- Select a Circuit Breaker of 45A (or next available appropriate range) with

Thermal Setting at 35.6A and

Magnetic Setting (Short Circuit) at 356A

Example 1: Capacitor alone

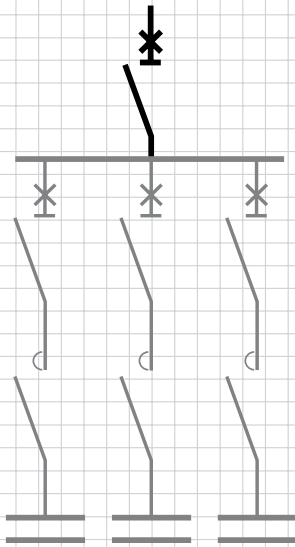

Individual capacitor protection by circuit breaker

Example 2: Capacitor with detuned reactors

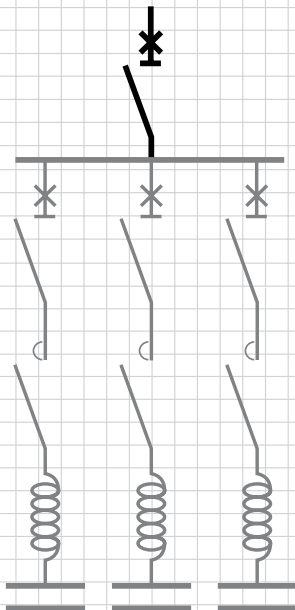

Individual capacitor protection by circuit breaker

Capacitor bank protection by means of a circuit breaker

DE121445



General

- Indoor installation on firm support in a correctly ventilated local or metal enclosure.
- Ambient temperature around capacitors must not exceed 35°C over one year, 45°C over 24hours and 55°C max (according to IEC 60831 for -25/D temperature category).
- Maintain a gap of min. 30mm between capacitor units and min. 30mm between capacitors and panel enclosure for better air circulation
- Electrical clearance between phases shall be 30mm.
- For 3ph capacitors keep min. 30mm gap above the top of the capacitor
- Use capacitor duty contactor or inductor coil in series with any two phases in order to limit the inrush current when capacitors are switched in parallel with other energized capacitor units.
- Please ensure that there is no force by any means on the Pressure Sensitive Disconnector (PSD) in such a way to affect the operation of PSD when it is required to operate.

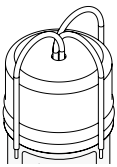

Double Fast-On +
Cable

Terminals

Double Fast-On + Cable

For lower ratings Double fast-on terminals with cables are provided (for rating $\leq 10\text{kvar}$)

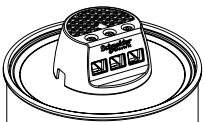

Clamptite

CLAMPTITE terminals

The unique finger-proof CLAMPTITE termination is fully integrated with discharge resistors and allows suitable access to tightening and ensures cable termination without any loose connections. Once tightened, the design guarantees that the tightening torque is always maintained. (for rating $> 10\text{kvar}$, up to 30kvar)

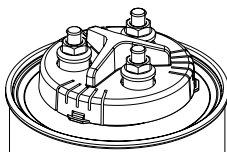

Stud Type

STUD type terminals

This type of terminals are used for proper current handling capabilities in capacitors of $40\&50\text{kvar}$

▲ WARNING

It is recommended to go through the installation guidelines manual provided with each and every Schneider Electric capacitor, and follow the instructions carefully.

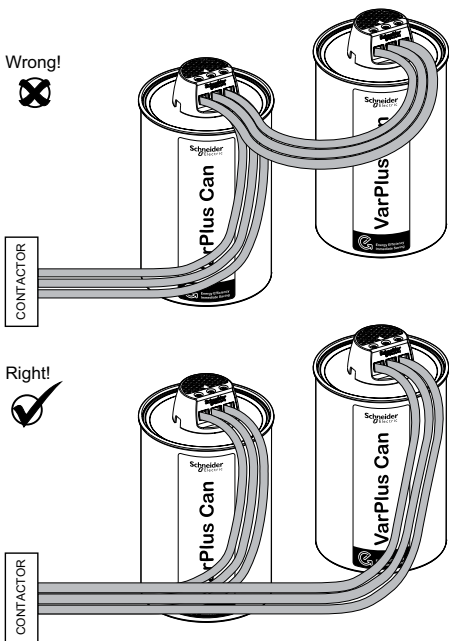

Electrical connection

- Select the cable cross section depending on the kvar & voltage rating –see cable Selection.
- User is recommended to use a cable of minimum with stand capacity of 105°C.
- Remove conductor insulation of the cable only 10mm for connection.
- Suitable size lugs have to be used with connecting cable to capacitor terminals in order to avoid heat generation due to improper contacts.
- Use pneumatic gun to tighten the screw from top of the CLAMPTITE terminal cover. If not possible, please ensure proper tightness when a screw driver is used to avoid loose termination. Apply a torque of 2.5Nm to tighten
- For Stud type terminals use a torque of 15Nm to tighten the Terminals after connecting cable using proper sized lugs.
- For tightening the VarplusBox terminal studs apply a torque of
 - for M6 studs - 4 Nm
 - for M8 studs - 8 Nm
 - for M10 studs - 12 Nm

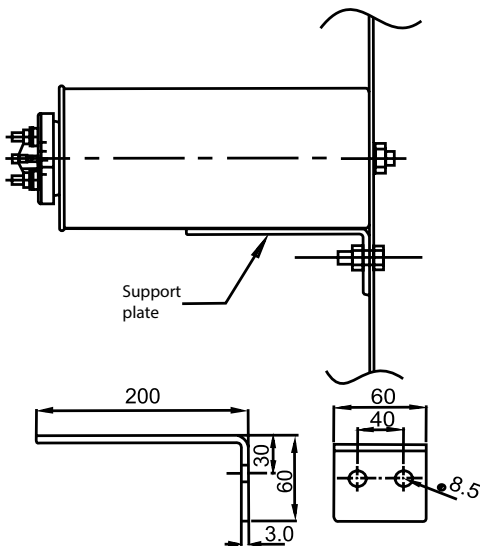

Mounting

- Capacitors can be mounted alone or in row.
- Position:
 - EasyCan : upright
 - VarPlus : upright or horizontal
- Capacitor body shall be earthed at bottom.
- Capacitor shall be installed in dry place away from heat generating source & avoid dusty atmosphere
- Provide adequate cross ventilation for heat dissipation
- Apply a tightening torque of 8Nm to fix the VarPlusBox capacitor on the mounting plates.
- Tightening torque of 10Nm to be applied on Hexagonal mounting nut for VarPlusCan(see picture in the left).

* All dimensions are in mm

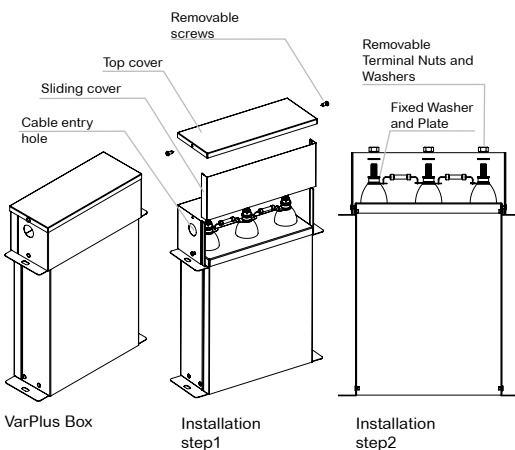

Cable cross section to be used to connect the capacitors

kvar rating	Cable Size in mm2					
	230V/240V		400 ≥ V 575		≥ 575V	
	Al	Cu	Al	Cu	Al	Cu
5	-	2.5	-	2.5	10	6
7.5	10	6	-	4	10	6
10	10	6	10	6	10	6
12.5			10	6	10	6
15			10	6	10	6
20			10	6	10	6
25			16	10	10	6
30			16	10	10	6
40			-	16	16	10
50			-	25	16	10
57.1			-	35		
68			-	35		

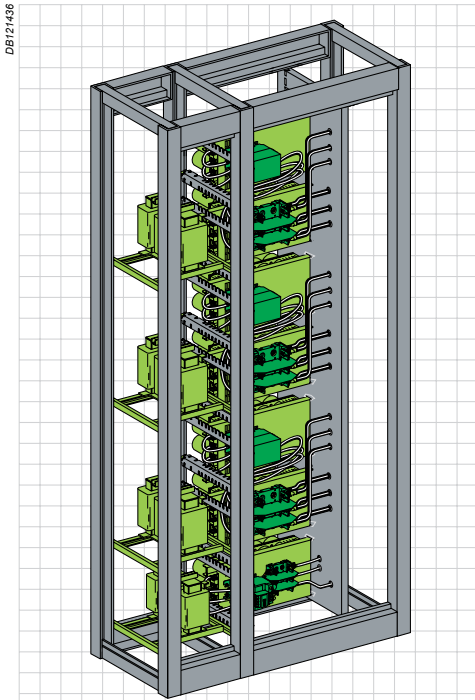

Example (1) of capacitor bank with reactors where reactors are in a separate column

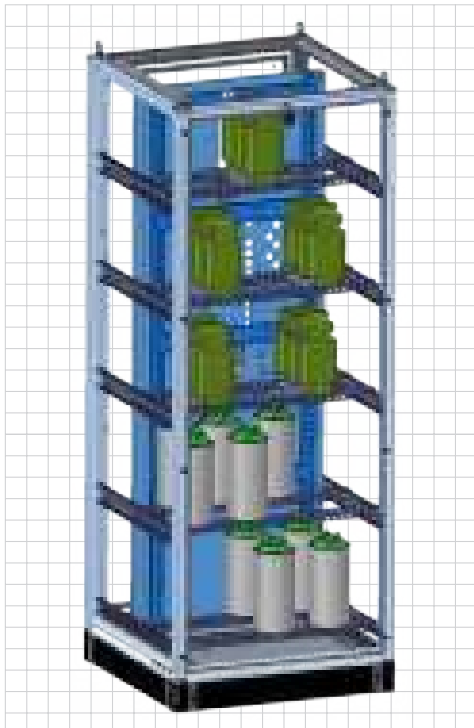

Example (2) of capacitor bank with reactors where reactors are in the same column as capacitors

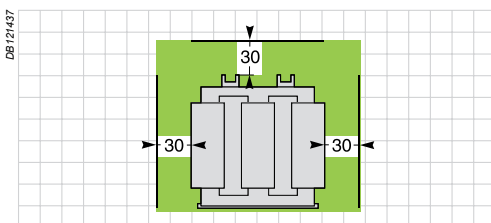

All dimensions are in mm

Temperature rise in detuned reactors

Detuned reactors operates at very high temperature compared to standard operating temperature of capacitors. The temperature around the reactor, should be maintained <55 degrees, which is the Operating temperature limit of the capacitor bank.

The recommended architecture of a PFC switch board with detuned reactors is with a separate column, specifically reserved for the reactors. (See picture)

The mounting of PFC components and its suitability should be re validated by a Temperature Raise Test as per IEC 61921.

Detuned reactors require forced ventilation.

Note: under no circumstances may the detuned reactors be fitted beneath the capacitors.

General instructions for installing detuned reactors

Refer to the user manual for detailed explanations.

- Reactor should not be mounted near the capacitors.
- Reactors should be mounted on the channels or steel rails described in the schematic below. Reactors should not be mounted on a sheet which blocks the ventilation.
- There should be adequate ventilation to provide sufficient cooling.
- Please refer to the "installation rules in APFC panels" in this guide for appropriate fan selection.
- Reactors must be mounted vertically and sufficient space must be provided for air to flow from bottom to top of the panel.
- If capacitors and reactors are mounted in the same column , please ensure that the heat generated by reactors won't impact the performance of capacitors. In the illustration example (Example 2) given here reactors are mounted in the top to ensure that the heat will follow to the top due to the forced ventilation and it doesn't affect capacitors.

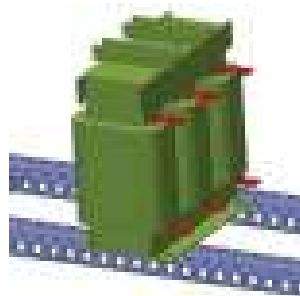

DB121427

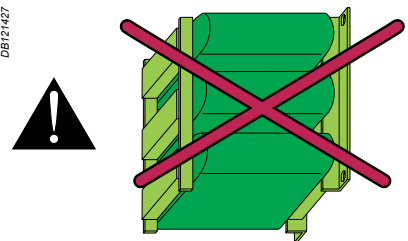

Installation distance

The minimum distances illustrated opposite must be observed for insulation purposes and to prevent overheating.

▲ WARNING

Force ventilation is mandatory while installing detuned reactors.

Installing reactors near to capacitors can reduce the life expectancy of capacitor.

It is mandatory to connect thermal protection contact to trip the breaker while connecting detuned reactors.

The temperature around the reactor, should be maintained < 55 degrees, to which it is designed (Operating temperature of panel) through proper ventilation.

Maximum kvar per step in Automatic power factor correction (APFC) capacitor bank

For Capacitors

There are no restrictions in number of capacitors to be put in parallel; the following points have to be taken care of before deciding the maximum kvar per step

- a) Contactor rating.
- b) VA burden of the relay.
- c) Ventilation
- d) Minimum clearances
- e) Installation rules for paralleling of capacitors (see page: 42)

a) Contactor Rating

Capacitor duty contactors are normally rated up to 60kvar. Whenever higher rated steps exist such as 75kvar, 100kvar or 120kvar, the contactors are connected in such a way to be operated by a single contact of the relay.

However for rating 120kvar and above AC3 duty contactors can be used along with the suitable inductor coils in series with capacitors in two phases for suppressing the inrush current. (refer to selection of capacitor switching and protection devices - Contactors)

b) VA burden of the relay

The maximum kvar per step also depends on the VA burden of each output contact of the power factor relay. The coil rating of all the contactors in the step should not exceed the VA burden of the relay contact.

c) Ventilation

The maximum ambient temperature on the capacitors is +55°C. The capacitors have to be placed in the rack in such a way that temperature should not exceed this limit. So, proper ventilation is very much required.

d) Minimum clearances

For better air circulation, a minimum clearance of 30mm between capacitor units and panel enclosure need to be kept. Also maintain a 30mm gap above the top of the capacitor. These are the points to be considered while deciding the number of capacitors in a rack.

Installation rules Automatic Power Factor Correction (APFC) capacitor banks

Enclosure

Enclosure provides protection for the components used in the APFC panel against ingress of external solid or liquid particles. Enclosures are made up of CRCA (Cold Rolled Cold Annealed) high carbon steel. The enclosures shall be thoroughly degreased and cleaned and phosphate coated before primer coats & powder coating.

Enclosure shall allow easy access of components inside the APFC Panel. Proper electrical clearances must be maintained inside the panel to ensure safety and ease of maintenance. Utmost care shall be taken for the design of enclosure and layout of all the parts and components in such a manner that it gives easy access for maintenance (Especially the components on the front door for aesthetic appearance).

Enclosure must be designed to ensure proper ventilation; necessary louvers shall be made at the required area for proper ventilation. These louvers shall be closed with wire mesh or perforated sheets of required size from inside to achieve the specified Ingress Protection(IP) levels.

Size of enclosure

Selecting the enclosure size is an important aspect, which accommodates most of the components in it and the size of the enclosure should be selected properly after a proper layout of components is made, in order to maintain the electrical clearances, ventilation and safety. The heat generating components should be located in such a manner that the heat generated does not come in contact with other components, especially which are sensitive to heat. A proper air flow has to be planned. Size of the enclosure depends on the following points.

- Total kvar rating of the APFC system.
- Type of APFC Panel, normal or harmonic filter panel.
- Number of physical steps.
- Type of incomer protection (SDF, MCCB or ACB).
- Type of outgoing protection (HRC Fuses, MCB or MCCB)
- Type of capacitors (application & construction based) and number of capacitors in the panel.
- Cable entry - Bottom or Top.
- Installation type - Outdoor or Indoor.
- Bus bar sizing and positioning in panels

PFC Bank design consideration

The failure of capacitor banks can be due to non compliance with any of the following design considerations.

- Discharge time (Clause 22, IEC 60831 - 75V in 3 minutes)
- Temperature (Clause 4.1, IEC 60831 – Class D, 55°C ambient)
- Temperature de-rating
- Ventilation requirement
- Overvoltage condition (Clause 5.3.5 IEC 61921)
- Resonance condition
- Over Load (Clause 5.3.7 IEC 61921 - continuous current - 1.3 times)
- IP (Clause 5.3.8 IEC 61921 - IP 20 for indoor application)
- Physical location of components and accessibility (Clause 5.3.9 IEC 61921)
- Protection & alarms (Clause 5.5.3 / 5.5.4, IEC 61921 - Fire Hazard)

Thermal safety in Automatic Power Factor Correction (APFC) capacitor banks

Ventilation inside the APFC Panel

Proper ventilation is essential to ensure good performance of the installed components in the APFC panel. Care must be taken to ensure that unimpeded airflow is maintained inside the panel. The accumulation of heat in an enclosure will potentially damage the electrical equipments. Overheating can shorten the life expectancy of components, especially the capacitors, which are highly sensitive to temperature and can leads to catastrophic failure.

Since adequate ventilation is required, sufficient louvers shall be provided at the bottom portion of the panel as inlet for air, and at top portion for exhaust. This gives a natural air flow from bottom to top inside the panel. For high kvar rated panels, this natural air flow has to be assisted by forced ventilation using exhaust fans at the top to have quicker replacement of hot air inside with cool air from outside and maintain the internal ambient temperature of the panel at the desired level.

Note: Providing louvers throughout the height of the panel is not recommended since it doesn't give the ducting effect for air flow.

Selection of fan and installation of thermal switch

It is recommended to use fans with thermal switches. In this case the positioning of the fans should be taken care so as to not place the fan's thermal switch close to heat dissipating devices so as to avoid any malfunctioning of thermal switch.

Recommendations:

Install two thermostats on the top section of the capacitor bank away from the heat dissipating devices.

- First thermostat to switch on the fans , when the internal temperature exceeds 35°C.
- Second thermostat to trip the capacitor bank if the internal temperature exceeds 55°C.
- Ensure that the detuned reactors are placed in a separate column as per our recommendations and the temperature sensed by the thermostat are not influenced by the detuned reactors.

The selection of fans shall be based on several parameters:

- Total watt loss including all components in the panel
- IP level of the panel
- Total volume of the enclosure
- Outside ambient temperature
- Desired internal ambient temperature

The cubic meter per hour capacity of the fan and the ambient temperature at which the fan can continuously operate are also to be taken into account for deciding the number of fans.

The following are the conditions considered for fan calculation, and applicable only for this design. The design conditions are taken in such a way to take care of even extreme temperature of 50°C inside the panel (As the design is for higher temperature, safety factor will be very high)

- External temperature - (ambient) +40°C
- Enclosure dimension (see table)

Note: User can see the recommended practices for Ventilation in following pages with respect to the application.

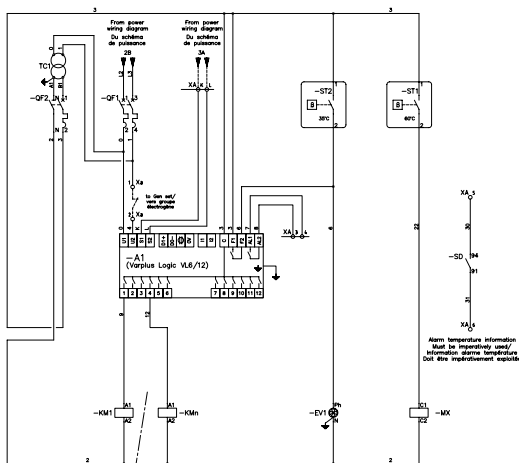

Typical control wiring for thermostat connection adopted in Schneider electric make capacitor bank VarSet.

ProClima

Determine the optimal thermal solution for your control panels



Schneider
Electric

The following rules apply to capacitor banks without reactor

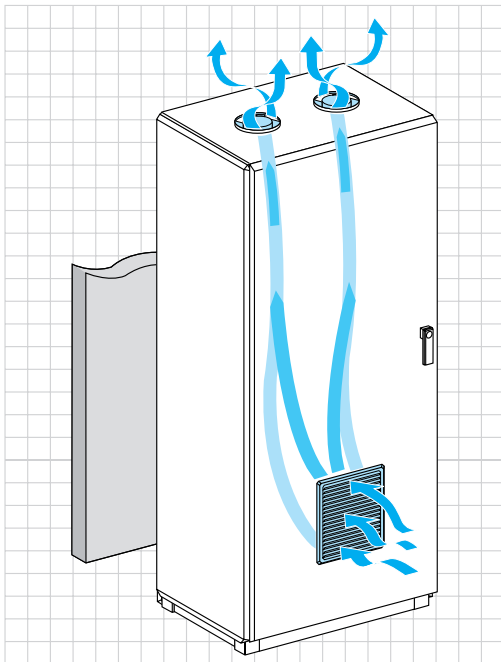

Ventilation Practices

Normal operating conditions according to IEC61439-1

- Maximum temperature in the electrical room: $\leq 40^{\circ}\text{C}$
- Average temperature over 24hrs in the electrical room: $\leq 35^{\circ}\text{C}$
- Average annual temperature in the electrical room: $\leq 25^{\circ}\text{C}$
- Minimum temperature: $\geq 5^{\circ}\text{C}$
- Maximum altitude: $\leq 2000\text{m}$

Other conditions, contact us

ProClima - Thermal modeling software

ProClima software processes a range of specified thermal data in order to propose the right thermal management choice to match the environment and electrical/electronic devices installed inside your control panel.

ProClima software takes into account variables such as:

- Temperature
- Humidity
- Sun radiation
- Indoor or outdoor settings

The program draws up a heat balance and defines the best ventilation, control, heating and cooling functions to match your installed equipment, with ProClima optimize your thermal management solution in order to minimize under- or over-sizing errors.

Ventilation rules

Capacitors without detuned reactors

Capacitors, contactors, fuses and electrical connections dissipate heat. These losses are approximately 2.5W/kvar. Calculate the losses and use the table mentioned in the next page. The following ventilation rules must therefore be complied with:

- The air within the cubicle must flow upwards.
- It is recommended that extractor fans be fitted on top of the cubicle.
- The bottom air inlet must be as low as possible for better ventilation
- The cross-section of the top air outlet must be more than the cross-section of the bottom air inlet
- The openings must be compatible with the safety rating (IP)
- There should be at least 100 mm between the fan and the modules or components
- The air inlet at the bottom air intake grille must not be obstructed or restricted by a component or module
- Always let a gap of minimum 600 mm between the back of the panel and the wall for a front open panel and a minimum gap of 1000 mm for the rear opened panel. It allows to have a good ventilation
- Take into account the pressure drops of the air inlet and outlet
- As an indication, the real airflow is 0.6 to 0.75 time the airflow announced by the fan manufacturer

Air Inlet

- Up to a power of 100 kvar panel need to have air inlet of 200cm²
- From 100-200kvar panel need to have air inlet of 400cm²
- Thermal modeling can be done using softwares like ProClima to ensure the design meets all the ventilation needs

The following rules apply to Capacitor banks with reactors

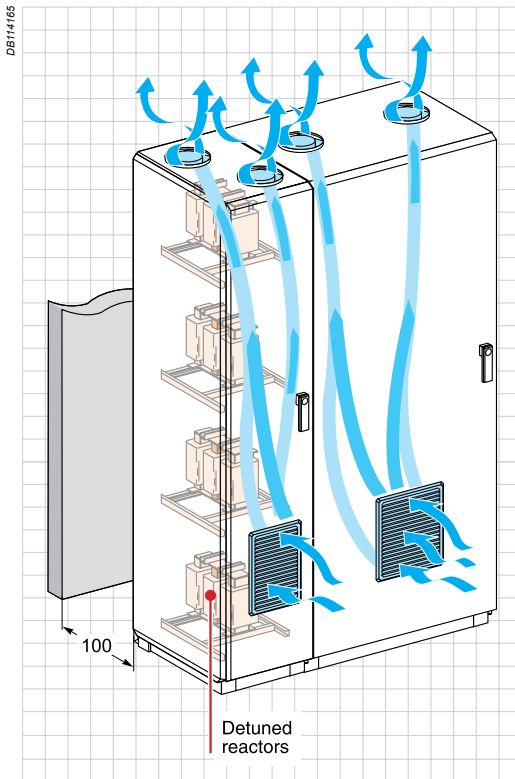

Ventilation for capacitor banks with detuned reactors

Capacitors, detuned reactors, contactors and electrical connections dissipate heat.

These Losses are approximately 9W/kvar. Calculate the losses and use the table below with respect to Watt losses.

This equipment must always **include a forced ventilation system**.

- The detuned reactors must be installed: in a separate enclosure or in the same enclosure as the capacitors, but in a separate compartment, or possibly above the capacitors.
- The part of the enclosure containing the capacitors must be ventilated according to the standard capacitor bank rules.
- The part of the enclosure containing the detuned reactors must be ventilated according to the dissipated power.

The ventilation rules in the previous page are applicable here also. Ventilation fans are required with respect to Watt losses. (The designs are made based on the assumption of the system as described above. Any special system conditions need consultation of Schneider Electric. It is always preferred to do thermal study before fixing the ventilation in the panel)

Selection of Fans

User can make use of the following rule of thumb for estimating the throughput required by the fan for a given capacitor bank.

However it is recommended to do a detailed thermal modeling to ensure the temperature rise inside the enclosure is within limits.

Recommended calculations for fan selection

Maximum throughput of fans required for a capacitor panel(*)
= 0.3 x Total power dissipated by the panel

Example 1: 200kvar panel without detuned reactors
Total Power dissipated by panel = $200 \times 2.5\text{w/kvar} = 500\text{W}$ / Panel

Maximum throughput of Fan required = $0.3 \times 500 = 150 \text{ M}^3/\text{h}$
User can use one fan of 160 M³/h for this panel.

Example 2: 200kvar panel with detuned reactors
Total Power dissipated by panel = $200 \times 9.0\text{w/kvar} = 1800\text{W}$ / Panel

Maximum throughput of Fan required = $0.3 \times 1800 = 540 \text{ M}^3/\text{h}$
User can use two fans, of 300 M³/h

(*) - Considering the normal operating temperature as per IEC 61439-1

User Tip:

Fixing the fans for Detuned reactor column vs other columns need to be in a ratio of 2:1.

Example: If the thump rule calculation above gives total fan selection of 540M³/h, user need to put 360M³/h fan for the reactor columns and 180M³/h fan for the other section.

Minimum number of fans required in the panel

without detuned reactors

kvar Rating	Watt loss	Fan through put required	Number of fans*	Throughput per fan
100	250	75 M ³ /h	1	85 M ³ /h
200	500	150 M ³ /h	1	165 M ³ /h
300	750	225 M ³ /h	2	165 M ³ /h
400	1000	300 M ³ /h	2	165 M ³ /h
500	1250	375 M ³ /h	3	165 M ³ /h
600	1500	450 M ³ /h	3	165 M ³ /h

with detuned reactors

kvar Rating	Watt loss	Fan through put required	Number of fans*	Throughput per fan
100	900	270 M ³ /h	2	165 M ³ /h
200	1800	540 M ³ /h	2	300 M ³ /h
300	2700	810 M ³ /h	3	300 M ³ /h
400	3600	1080 M ³ /h	4	300 M ³ /h
500	4500	1350 M ³ /h	2	560 M ³ /h
600	5400	1620 M ³ /h	2	560 M ³ /h

ClimaSys CV - Forced ventilation product range

Cut out Dimension	Air Flow	Voltage	Reference
125 x 125	85 M ³ /h	230V 115V	NSYCVF85M230PF NSYCVF85M115PF
223 x 223	165 M ³ /h	230V 115V	NSYCVF165M230PF NSYCVF165M115PF
223 x 223	302 m ³ /h	230V 115V	NSYCVF300M230PF NSYCVF300M115PF
291 x 291	562 m ³ /h	230V 115V	NSYCVF560M230PF NSYCVF560M115PF
291 x 291	850 m ³ /h	230V 115V	NSYCVF850M230PF NSYCVF850M115PF

Recommended Enclosure sizes

The following table gives the examples for the panel dimensions for better Ventilation

kvar rating	Total no. of steps	Panel dimension (H x L x W)mm	
		With reactor	Without reactor
100	4	1800 x 800 x 800	1800 x 800 x 600
150	6	1800 x 800 x 800	1800 x 800 x 600
200	6	1800 x 800 x 800	1800 x 800 x 600
250	7	2000 x 800 x 800	2000 x 800 x 600
300	8	2000 x 800 x 800	2000 x 800 x 600
350	8	2000 x 800 x 800	2000 x 800 x 600
400	8	2000 x 800 x 800	2000 x 800 x 800

⁽¹⁾ The number of fans recommended can be followed only if proper ventilation of all the components as per the design rules of the components are implemented with the recommended enclosure sizes and also ensure the recommended mounting distance from the wall.



Protection of panel is to protect both the enclosure and the equipment inside the enclosure, against external influences or conditions such as

- Mechanical impacts,
- Corrosion
- Corrosive solvents
- Fungus
- Vermin
- Solar radiation
- Icing
- Moisture (for example, produced by condensation)
- Explosive atmospheres
- Protection against contact with hazardous moving parts external to the enclosure (such as fans)

Degree of protection

Degree of protection (IP) is represented by two numerals and two optional characters

IP	0-6	0-8	A-D	H M S W
----	-----	-----	-----	---------

See standard IEC 60529

Acceptable degree of protection is IP 4X for most of the APFC panels. For dusty environment, a higher level of ingress protection is recommended. A higher IP level gives reduction in cooling and hence special cooling system should be designed (i.e. air conditioning) and better ventilation.

In Schneider electric capacitor banks - VarSet- we give 3 options to customer which are IP31, IP42 & IP54.

Extreme care need to be taken while deciding the ventilation for higher IP configuration else it can impact the life of temperature sensitive components like capacitor.

Earthing

Earthing or grounding means literally to make an electrical connection between the ground and a metallic body. The main reason for doing this is safety. The term ground is often used to mean a part of the circuit which has zero volts on it.

The main objectives are as follows

- Provide an alternative path for the fault current to flow so that it will not endanger the user.
- Ensure that all exposed conductive parts do not reach a dangerous potential.

Earthing safety points to be adhered for panels are as follows:

- Interconnect all earthing points of door mounted metallic components and all non-current carrying parts of control wiring. Connect finally to panel earth bus with suitable cable.
- Interconnect all earthing points of power circuit components (capacitors, reactors, switches etc).
- Provide coupling links for connecting the earth bus sections at site.
- As per standards two earth terminals must be provided for panels.
- The earth must be designed based on the system fault level at the location.

Temperature grade of cables

Power and control cables in the capacitor bank need to be selected according to the ambient temperature, application and the heat dissipation characteristic of components used.

For a normal operating conditions according to IEC61439-1 (Maximum temperature in the electrical room: $\leq 40^{\circ}\text{C}$) user could use 105°C grade cables for the power cable selection.

Cables are used for power circuit and control circuit in APFC system. Choosing a proper and adequate cable is of very much importance. The selection of cable depends on the following points.

- Voltage Rating.
- Ampere Capacity.
- Heating Conditions.

Voltage Rating

The type and thickness of insulation is determined by the voltage grade. It also helps in determining the minimum size of conductor that is suitable for loads.

Ampere Capacity

Current carrying capacity of the cable is selected based on the maximum current rating of each step.

Heating conditions

Include the external thermal conditions which are responsible for determining the temperature increment of a cable.

Some important factors to be considered during selection of cables are

- Ambient temperature
- Presence of artificial cooling
- Proximity to heating elements.

Step Power cable selection

Flexible, or semi rigid copper cables are generally used inside the Panel.

- It shall have a voltage class of 1100V grade.

For a working voltage that is less than half the insulation voltage of the cable, i.e $< 550\text{V}$, these cables are considered to be class 2.

Therefore they can be flanged directly to metal supports without use of any additional insulating material.

The Cable cross section must be compatible with:

- The current to be carried
- The ambient temperature around the conductors.

Dimensional Rules:

- The ambient temperature inside the electrical room must not exceed 40°C
- The Cables must be appropriate for a current of at least 1.5 times the capacitor current at a temperature of 50°C
- The maximum temperature inside the enclosure must not exceed 50°C

Auxiliary Circuit cable selection

Unless otherwise stated in specifications, the following cable cross sections are recommended for auxiliary wirings.

- 1.5 mm² copper wires for the auxiliary voltage circuits
- 2.5 mm² copper wires for current circuits- CT secondary connection and for earthing
- It should have a voltage class of 1100/660V grade or more.
- The cables must be multi strand, single core and PVC insulated.

Capacitor Bank connection Cable Selection

- Power conductors are chosen to carry continuous current of 1.5 times the rated current
- Power cables are used for interconnection between bus bar, step protection, switches, reactors and capacitors.
- The cables shall be multi strand, single core and PVC insulated.
- Minimum of 4 mm² power cable is considered for connection capacitor step up to 10kvar
- Maximum of 35 mm² cable is considered for 50 kvar step.
- And for higher rated steps of 75 or 100kvar, 2 numbers of 35 mm² cable are generally used in parallel.

Various manufacturers of cables distinguish cables based on cable diameter, current carrying capacity and type. Hence it is necessary to select cables suitably to meet the needs in APFC panels

Note: selection of suitable lugs is very much important in order to achieve a proper joint. Proper crimping of these lugs to the cables should also be ensured. Only 2 lugs are permitted in one hole for termination (i.e. at either sides of the hole and not one above the other).

Recommended size of cables and lugs for contactors and switchgear connection

User Tip:

Conductor sizes and connecting methods for capacitors are detailed in the capacitor installation rules in this guide.

kvar rating	Cable Size in mm ²						Lug Size
	230V/240V		400 ≥ V 575		≥ 575V		
	Al	Cu	Al	Cu	Al	Cu	
5	-	2.5	-	2.5	10	6	M5/M6/M8 Pin type, fork type or ring type based on the terminal of the components
7.5	10	6	-	4	10	6	
10	10	6	10	6	10	6	
12.5			10	6	10	6	
15			10	6	10	6	
20			10	6	10	6	
25			16	10	10	6	
30			16	10	10	6	
40			-	16	16	10	
50			-	25	16	10	
57.1			-	35			M5/M6/M8 fork type or Ring based
68			-	35			

**The above details/specifications will vary from manufacture to manufacture. Calculations are based on standard operating conditions.

Layout of various components in APFC panels

Components layout is prepared based on the arrangements of switchgears, capacitors, reactors and other components to be installed in the APFC panel. The others also include Bus bars, incomer cable entry whether at bottom or top, fans, etc.

Usually capacitors, switch gears and reactors are provided at separate locations, however between capacitors and reactors a complete partition should be provided. Capacitors are mounted vertically on a separate metal channel, tightened by the mounting screw to avoid dislocation. Capacitors are transposed and placed when arranged one below the other in racks. This arrangement gives better cooling to all capacitors equally. Capacitors are sensitive to high temperature and hence proper care will have to be taken while locating them.

Reactors operate at much higher temperature than capacitors. Placing reactors adjacent to capacitors or below them will harm capacitors. Capacitors will be subjected to reactors heat and the operating performance will be affected. Hence capacitors and reactors are not assembled together and a complete partition is required between them.

The cables connecting the components run in cable alleys, properly numbered for respective steps.

Inspection- Applicable tests and procedure for conducting in APFC panels

Tests according to IEC 61921 to validate the APFC design is conducted

- A. Type Tests
- B. Routine Test

A. Verification of type tests

- Temperature rise test
- Dielectric properties
- Short circuit withstand strength
- Effectiveness of the protection circuit
- Clearance and creepage distances
- Mechanical operation
- Degree of protection

B. Routine Test

- Inspection of assembly including inspection of wiring and if necessary electrical operation test
- Dielectric test
- Checking of protective measures and of the electrical continuity of protective circuit
- Verification of insulation resistance

Principle

Practical rules

At the end of the manufacturing process, a LV switchboard must undergo various routine inspections and tests in the factory, following an established programme.

The switchboard must comply with:
the appropriate standards
the design file (drawings, diagrams and specific requirements)
manufacturer mounting instructions
in-house instructions.

Test conditions

Tests must be carried out in a clearly defined area, in compliance with applicable legislation or regulations, by qualified personnel.

Inspection is carried out in a special area referred to as the test platform which is set aside for final testing. All inspectors must first attend a special training course and must be qualified for working in the proximity of live parts.

Inspection means

The necessary parts should be suitable for the purpose, correctly calibrated and in good working order:

- dielectric test station
- megohmmeter
- multimeter
- capacitance meter
- torque wrench
- controller test bench...

The reference documents

The main international standards are:
IEC 61439-1/2, IEC 60529, IEC 60831-1&2 and IEC 61921.

In addition to those items which are specific to the switchboard: drawings, diagrams and specific specifications, quality inspectors should refer to up-to-date documents, integrating revisions and updates:

- to technical files
- to in-house rules, etc
- keeping track of changes in standards in order to have the most recent version at all times



Megohmmeter.

Practical rules

Carry out all the compulsory inspections and tests and in particular the three routine tests specified by the IEC 61439-1/2 standards.

They complement any type tests which may have been carried out previously by the manufacturer.

Standard IEC 61439-1/2 defines 10 tests to be carried out on electrical switchboards:

- 7 type tests
- 3 routine tests.

The 7 type tests must be carried out in laboratories and test platforms on cubicles, using real working configurations: complete cubicles fitted with standard components and equipped with VarplusCan and VarplusBox capacitors.

The assembly instructions and the 3 routine tests (described below) provide the necessary proof that the switchboard is of the Type Tested Assembly (TTA) or Partially Tested Assembly (PTA) type, and in compliance with standards.

1st routine test

Inspection of the assembly, including inspection of wiring and, if necessary, an electrical operation test.

Conformity

- conformity of the finished switchboard to the drawings, part lists and diagrams:
- number, type and rating of devices
- conformity of cabling: auxiliary and power circuit connections
- quality of cables: conductor cross-section, crimping and tightness
- marking of conductors and devices.

Visual inspection

- check clearances and creepage distances at connections or part of busbars
- check the degree of protection. Presence of protective elements, according to requirements (canopy, gasket, front plate, etc.). No enclosure infractions (cut-outs, holes, etc.) that might compromise the original degree of protection
- check the presence of a name plate or technical documentation showing the manufacturer's name, the project identity number and all the technical specifications relevant to the LV correction switchboard (kvar, voltage, frequency, etc.)

Electrical operation

- Inspect the cables and check the proper operation of the LV correction switchboard, preferably using a "controller test bench" (attached diagram).
- Capacitance measurement : Check the capacitance of each step. One measurement between two capacitor terminals is sufficient:
Refer annexure 2, formula 4 for Q value (in kvar) analysis from capacitance measured.



Dielectrometer



Multimeter

2nd routing test : Insulation testing

Dielectric test:

All devices must be connected, with the exception of those incapable of withstanding the test voltage (disconnect the controller). Tests must be done with all the contactors closed. For a switchboard with voltage rated up to 690 V, apply a test voltage of 2500 V - 50 Hz for 1 second minimum, between all the live parts and the interconnected frames of the assembly.

Note: due to capacitor presence, the test must be performed between the 3 short-circuited phases and the earth.

The tests are satisfactory if there is neither puncture nor flashover between the various parts being tested.

Alternative solution:

If the switchboard is not subjected to a dielectric test, an insulation measurement must be taken using an insulation tester, with a voltage of at least 500 V (DC). The minimum insulation resistance value must be higher than 1000 ohms/V.

3rd routine test : Protective measures

Check for the presence of barriers to protect against direct and indirect contacts with live parts.

Visually check that:

- Contact washers have been used on all assemblies
- Earthing wires have been fitted to doors
- The PE conductor is present and must be connected.

Finishing

Clean the inside of the switchboard

Check presence of switchboard identification markers

Check external appearance: scratches, paintwork, etc.

Reports

Create a non quality input document used to quantify faults, evaluate their importance and assign them to relevant department that must take the necessary action to ensure conformity of the electrical switchboard.

Practical rules

Conformity of production:

- Draw up a list of missing items
- Draw up a list of equipment which will be dispatched separately from the switchboard.

Conformity of operation:

- Issue a test report
- This report notes any anomalies detected and the required corrective measures
- Establish with the customer, a check list of all the points to be checked (example enclosed)
- Issue a test report that remains in the panel-builder's possession but that can be supplied on request
- this report certifies that all the tests have been carried out and avoids repeating all tests a second time once on site.

Each panel-builder has his own test documents.

Customer: Project no: Cust. order no: Workpost:

Inspection performed by: Signatures: Q.I: Device:

.....

kvar V Hz

Inspection operations			Comments Q.I
1- dielectric test	test 2500 V - 50 Hz - 1 second minimum insulation measurement at 500 V CC		
2a- conformity			
Capacitor (kvar)	conform	not conform	
Fuse (A)	conform	not conform	
Contacteur (type)	conform	not conform	
DR (mH)	conform	not conform	
DR (A)	conform	not conform	
Cable cross-section	conform	not conform	
Busbar cross-section	conform	not conform	
Connection pads	conform	not conform	
Earth circuit	conform	not conform	
Component identification	conform	not conform	
Conductor identification	conform	not conform	
Rating plate	conform	not conform	
Documentation	conform	not conform	
Frame continuity	conform	not conform	
Degree of protection	conform	not conform	
Locking	conform	not conform	
Presentation, appearance	conform	not conform	

Inspection operations	Steps no.												Comments Q.I
	1	2	3	4	5	6	7	8	9	10	11	12	
2b- operation													
Contacteur	OK	OK	OK	OK	OK	OK	OK	OK	OK	OK	OK	OK	OK
Controller	conform						not conform						
Indication	OK	OK	OK	OK	OK	OK	OK	OK	OK	OK	OK	OK	OK
2c- capacitance measurement C between Ø (mF)													
Capacitor no. reading													
	no	no	no	no	no	no	no	no	no	no	no	no	no

Observations :

.....

.....

.....

.....

.....

.....

Customer:	Customer order no:
Project no:	
List of equipment	
Workpost number:	Description:

Inspection performed

1- Conformity inspection

- Enclosures :
- Switchgear :
- Conductors :

2- Mechanical checks :

3- Electrical continuity of mechanical frames

Resistance value : mΩ Visual :
 Electrical :

4- Dielectric tests (2500 V - 50 Hz - 1 second minimum) :

5- Insulation resistance monitoring (500 V DC) :

Resistance value : mΩ

6- Electrical operating tests :

Observations :
.....
.....
.....
.....

Conclusion :

- equipment accepted without reservations. equipment refused, to be presented for re-inspection.
- equipment accepted with reservations.

Customer inspection	Acceptance test organisation	Inspector	Q.I manager
Date:	Date:	Date:	
Signature:	Signature:	Signature:	

Packing design is carried out with due consideration to the mode of transport.

The packing design shall be based on the following

- The panel outer dimension.
- Total weight of the panel.
- Position of components/ equipments mounted on the front Panel
- Position of heavy components placed inside the enclosure
- Place of delivery
- Mode of transport
- Type of loading and unloading
- Storage conditions at site

The panels are provided with the following

- Proper lifting arrangement - for the panel and the complete assembly
- Protection against rain, spillage of water or liquids by properly covering the entire enclosure.
- Protection for meters display and instruments on the front panel
- Desiccants to ensure removal of moisture during transportation and storage.

Packing Sequence

- Application of Hessian cloth against shocks
- Thermo Cole to protect instruments, meters - refer Fig 1
- Application of stretch film & bubble film on the panel
- Placement of kurlon spacer on the panel to act as spacer between panel and side/top /rear shocks
- Inclusion of silica gel bags
- Printing / labels / Signs to indicate upright position - refer Fig 2



Fig 1

Handling of packed Panels

Road Transport

During Transport it is necessary to protect the panel from vibration & jolting by proper anchoring in the truck bed.

- While loading and unloading the panel onto or from the truck, use a crane or fork lift, depending on the weight and size of the panel, especially a loading platform is preferable
- DO not push the panel up or down a ramp.
- Alternatively, the crate can be lifted vertically by sling and pulley hook, to ensure safety to the panel and personnel.

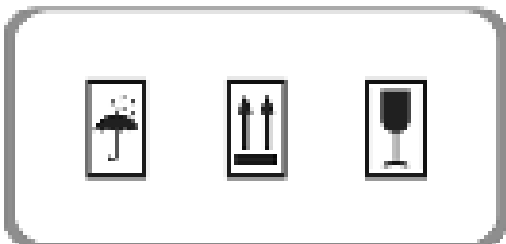

Fig 2

It is also necessary to instruct the site/ commissioning personnel to handle the packing for movement of the panel to erection site by using crane/ trolley truck to avoid physical damage.

Sea Transport

- Steps should be taken to protect the equipment from corrosion, humidity and rain.
- Suitable marks and indications should be given on the crate for applying slings for lifting on to the ship deck.
- While shipping, it is necessary for the shipping agency to properly anchor the panel package to prevent roll over during transit.

The following are the figures referring to Do's and Don'ts

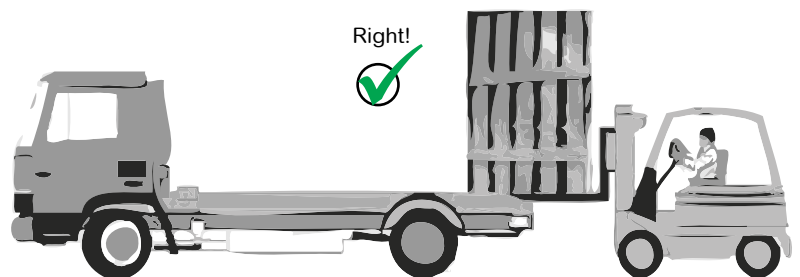
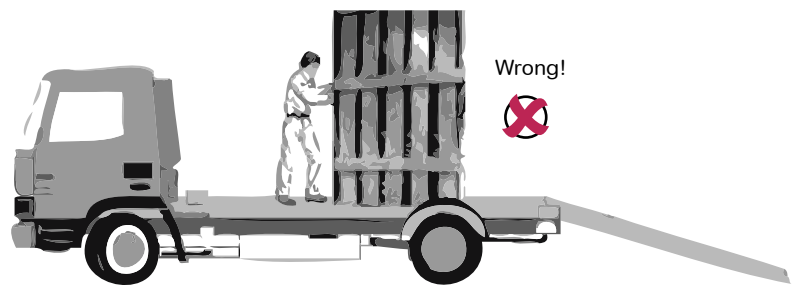
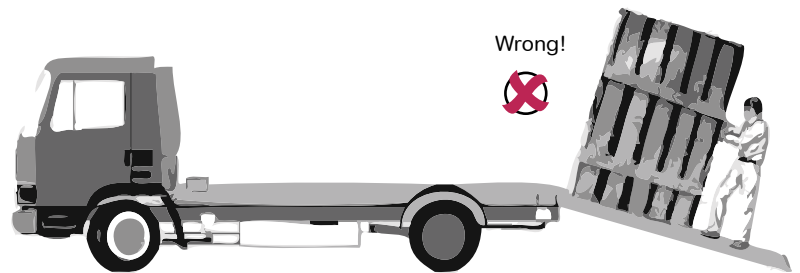

The Automatic Power Factor Correction (APFC) capacitor bank builder must, in all contracts, provide the user with a manual on proper procedures to be adopted during the stages of installation, commissioning and maintenance. This is particularly important when customers own staff undertakes erection and commissioning.

The manual covers, as a minimum, the following subjects:-

- Unloading, inspection and storage of packed panels.
- Unpacking and visual inspection of panel.
- Installation and cabling at final location.
- Setting of APFC relay.
- Live checks and observations to be made with supply 'ON', precautions needed during this phase.
- Recommendation for routine checks to be made after commissioning.

In all cases, copies of operating instruction manual of major components, such as APFC controller and protective relays, published by the respective manufacturers, should be provided to the user for use during installation.

Unpacking

- While unpacking, care should be taken to see that no sharp tools hits / hampers the surface of the panel and creates dents and damage the powder coated finish of the enclosure.
- A copy of this Instruction Manual along with a copy of the schematic drawing of the panel is also put in the panel. The same shall be read carefully and followed for the installation, commissioning, and operation of the equipment by the concerned officials at site.
- If any damage in transit or loss of components is observed during unpacking, this has to be intimated immediately to the concerned.
- Two panel keys are also supplied along with the panel.

Handling

- Attach ropes to the lifting hooks of the panel for handling. Never use hard tools like crowbars which can damage the panel while handling. As far as possible cranes should be used to lift and move the panels. Do not push and give jerks to the panel, and thereby jerks to the internal components.
- Keep the panel on a flat, firm, surface in the normal upright position. Do not keep it on side wise or upside down.
- Do not use the operating handles of MCCB, Switches, etc; for holding while handling.

Storage

- Do not store the panel uncovered even for a short period. Keep it covered at least with a polyethylene sheet.
- If it is not to be erected / commissioned for a longer period, keep the panel with the polyethylene sheet and store in a cool, dry, well ventilated, place, well protected from dust and corrosion, wet

atmosphere.

Installation and Commissioning

The panel can be grouted directly on the floor of the switchboard room, provided that proper trench for cabling has been made and the floor is leveled properly. No specific foundation is required.

Pre-commissioning check lists

Check list - 1

The following points should be verified before charging capacitor banks installed in Automatic Power Factor Correction (APFC) capacitor bank .

- Capacitor voltage rating is equal to or more than the maximum voltage recorded in the installation
- Capacitor is mounted and installed as per mounting and installation guidelines in this document
- The plant has the facility to trip the capacitor under over voltage conditions.(10%)
- Ensure each capacitor bank is provided with suitable protection devices.
- Suitable inrush current device is connected in series with contactor to limit the inrush current or capacitor duty contactor is connected.
- Capacitor is installed in the area free from entry of dust, chemical fumes and rain water.
- PF Controller provided in the panel should be set for 60 seconds On-delay. (Not applicable for capacitors used with the fast switching devices - Static Switched)
- The capacitor with detuned reactor banks are provided with MCCB for protection apart from above points. Use the switchgear selection guidelines for selection of breaker

Check list - 2

Following points are required to be verified before charging APFC panel.

- All the electrical connection is checked for loose termination in the panel.
- The CT is located before the cable connection of APFC panel towards source / main breaker of installation. Ensure the CTs are connected to the PF Controller.
- It is suggested to mount measurement C.T of the APFC Relay on the Highest current carrying phase (Eg: R) and the Voltage input for the relay is taken from other two phases (Eg: YB) . This is not applicable for a three phase sensing APFC relays.
- Neutral cable is connected to the panel.
- Current carrying capacity of cable in the APFC panel is rated equal to incomer switch current rating.
- Capacitor terminals are checked for any loose connection.
- Earthing bus is connected to the panel.
- All the control fuses are intact.
- If MCBs are used for step protection make sure they are

switched on.

- Emergency push button is released.
- Panel are installed in the area free from entry of dust, chemical fumes and rain water.

Check list - 3

Verify the following points in the installation before commissioning capacitor with detuned reactor banks.

- Capacitor banks without reactor should not be permitted on the secondary side of transformer circuit which is having capacitor + Detuned reactor banks connected. In this case please remove capacitors without reactors from the same network.
- Capacitors used with reactors are always of higher voltage than network voltage. Please do not use normal capacitor rated for network voltage.
- Earthing should be done at capacitors and reactors separately.
- Make sure all the cable and termination guidelines are followed.
- Forced cross ventilation should be provided in the installation area. If the filter banks are installed inside the panel the fans need to be provided.
- Detuned reactors are provided with thermal protection, the Normally Closed (NC) dry contact must be used to disconnect the step in the event of overheating.

Installation guidelines for APFC panel

- Shift the panel to the location where it is required to be installed.
 - a. Position the panel on the foundation and lock the panel base frame with the foundation bolts for free standing panels, by using spirit level and plumber block for achieving horizontal and vertical leveling.
 - b. Position the panel on the wall or structure and fix with wall mounting brackets provided along with the panel. Leveling should be done here also as explained above.
- Connect the earth conductor to the panel terminal provided on either side of the panel.
- Use the key provided to open the door of the panel and make sure that electrical connection of all equipments are intact. This is particularly important since vibration in transportation sometimes may have resulted in loose connections.
- The cable rated for current capacity equivalent to main incomer of panel should be used. Use suitable size lugs for connecting the power cables.
- Connect the cable to the terminals provided for the power supply. Make sure that the correct phase identification is maintained while connecting the incoming terminals to the panel with respect to phases of supply line, as any mistake will lead to the malfunctioning of relay.
- Connect the APFC relay as mentioned in the checklists.
- Check the preset values of the CT secondary current of the relay. It should match with the CT used.

Commissioning of APFC panel

- Connect the 3-phase incoming cable to the Incoming terminal of the Incomer Switch / Circuit breaker of the APFC panel.

- If the APFC controller / relay are programmable type, program the various settings as per instructions given in the respective instruction manual.
- Ensure that the CT shorting links are removed after the CT secondary connections are made properly.
- Keep the Auto /off / Manual selector switch in the Auto position.
- Ensure that the power supply to the Incomer switch is 'ON' from the glowing of the indicating lamps 'R', 'Y', and 'B'. Cross check the system voltage.
- Switch "ON" the Incomer MCCB / ACB of the APFC Panel.
- The APFC relay will be energized and displays the present power factor, when R-Phase load CT connections and phase sequence of voltage (Y & B) are correct.

Note: Before interchanging the C.T. secondary wires, ensure that the terminals of the C.T. are shorted by a small wire, which should be removed after the inter change.

Periodic Maintenance

The following periodic checks are recommended to be conducted

- Visual check of components and current carrying parts, especially bus bar.
- Check tightness of all electrical connections.
- Check current drawn by the individual capacitor steps.
- Check the operation of contactors manually by switching of the APFC equipment
- Visually check for rust and corrosions in bolts, nuts and other accessories
- Visually check for the sparks and burn outs in the panels.

Trouble Shooting in Capacitor

Symptoms	Cause	Remedial Action
Capacitor terminal over heating	<ol style="list-style-type: none"> 1. Proper size for lug is not used 2. Loose connection 3. Rating of cable is not adequate 4. Capacitor drawing over current 	<ol style="list-style-type: none"> 1. Check the size of lugs used and replace with suitable size 2. Tighten the loose connections 3. Check the cable current carrying capacity and change if required 4. Check the harmonics in Supply voltage
Over heating of capacitor unit	<ol style="list-style-type: none"> 1. Poor ventilation 2. Drawing excessive current 3. Over voltage 	<ol style="list-style-type: none"> 1. Ensure the ventilation for the installation area 2. Check for the harmonic presence 3. Check the system voltage and capacitor rated voltage. If required replace with capacitor of proper rated voltage
Capacitor drawing less current	<ol style="list-style-type: none"> 1. Low voltage 2. Failure of capacitor elements 	<ol style="list-style-type: none"> 1. Voltage to be maintained 2. Should be checked if the capacitors are installed and operated as per the guideline given 3. In case of elements failure due to excessive harmonic currents, capacitor should be replaced with reactor and higher rated capacitor.
Power factor is not improved	<ol style="list-style-type: none"> 1. Capacitor installed is not operated. 2. Supply transformer fixed compensation is not provided 3. Capacitors are not selected properly 	<ol style="list-style-type: none"> 1. Check the connections of the capacitors 2. Transformer should be provided with fixed compensation 3. Do the proper selection of capacitor as per the guidelines given.
Short circuit device operating frequently	<ol style="list-style-type: none"> 1. Short circuit rating/ setting is improper 2. Harmonic over loading 	<ol style="list-style-type: none"> 1. Do proper selection/ setting of short circuit device 2. Use special capacitor duty contactors for inrush current limiting in case of parallel switching 3. if it is harmonic overload, capacitor should be replaced with reactor and suitable capacitor.

Formula -1

The kvar of capacitor will not be same if voltage applied to the capacitor and frequency changes. The example given below shows how to calculate capacitor power in kvar from the measured values at site and name plate details.

$$Q_M = (f_M / f_N) \times (U_M / U_N)^2 \times Q_N$$

U_N = Rated Voltage
 f_N = Rated Frequency
 Q_N = Rated power
 U_M = Measured voltage
 f_M = Measured frequency
 Q_M = Available power in kvar

Example:

1. Name plate details – 15kvar, 3 phases, 440V, 50Hz capacitor.
 Measured voltage - 425V
 Measured frequency - 48.5Hz

$$Q_M = (f_M / f_N) \times (U_M / U_N)^2 \times Q_N$$

$$Q_M = (48.5/50) \times (425 / 440)^2 \times 15 = 13.57\text{kvar.}$$

2. Name plate details – 25kvar, 3 phases, 480V, 60Hz capacitor.
 Measured voltage - 464V
 Measured frequency - 59.5Hz

$$Q_M = (f_M / f_N) \times (U_M / U_N)^2 \times Q_N$$

$$Q_M = (59.5/60) \times (464/480)^2 \times 15 = 23.16\text{kvar.}$$

Formula - 2

The current of capacitor will not be same if voltage applied to the capacitor and frequency changes. The example given below shows how to calculate capacitor current from the measured value at site.

$$I_M = I_R \left(\frac{U_M \times f_M}{U_R \times f_R} \right)$$

U_N = Rated Voltage
 f_N = Rated Frequency
 I_N = Rated Current
 U_M = Measured Voltage
 f_M = Measured frequency
 I_M = Capacitor Current

Example:

Consider a capacitor of 15 kvar, 440V, 50 Hz, 3 Phase Capacitor
 Rated Current from name plate = 19.68A

Measured Values are: Voltage : 425V , Frequency : 49.5 Hz,

$$I_M = 19.68 \left(\frac{425 \times 48.5}{440 \times 50} \right)$$

$$= 18.43\text{A}$$

Note: Please ensure that the measurement is done using true RMS clamp meter

Formula - 3

Formula for calculating rated current of capacitor with rated supply voltage and frequency.

$$I_N = \text{kvar} \times 10^3 / (\sqrt{3} \times U_N)$$

Example

1. 50 kvar , 3 phase, 400V, 50Hz capacitor.

$$I_N = \text{kvar} \times 10^3 / (\sqrt{3} \times U_N)$$

$$I_N = (50 \times 1000) / (1.732 \times 400)$$

$$I_N = 72.16 \text{ A}$$

2. 37.7 kvar, 3 phases, 525V, 50Hz capacitor.

$$I_N = \text{kvar} \times 10^3 / (\sqrt{3} \times U_N)$$

$$I_N = (37.7 \times 1000) / (1.732 \times 525)$$

$$I_N = 41.45 \text{ A}$$

Formula - 4

The capacitance value of a capacitor can be calculated using following formulae for delta connected 3ph capacitor. Assume that capacitance of the three delta connected capacitors are C as shown in the figure.

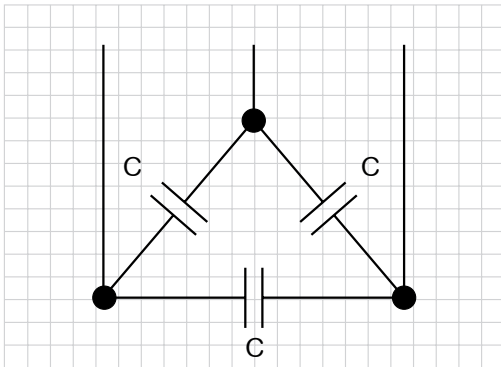

$$C = (2/3) \times Q_N \times 10^9 / (4\pi f_N U_N^2) \text{ for 3 phase capacitor.}$$

Example

1. 15 kvar, 3 phases, 415V, 50Hz capacitor

$$C = (2/3) \times 15 \times 10^9 / (4 \times 3.142 \times 50 \times (415 \times 415)) = 92.41\mu\text{F}$$

2. 15 kvar, 3 phases, 440V, 50Hz capacitor

$$C = (2/3) \times 15 \times 10^9 / (4 \times 3.142 \times 50 \times (440 \times 440)) = 82.2\mu\text{F}$$

Formula - 5

kvar calculation from the measured capacitance value of a capacitor.

$$Q_M = 2/3 \times (C_a + C_b + C_c) \times U_N^2 \times (2\pi f_N) / 10^9 \text{ - for three phase capacitor}$$

Example

1: Consider you have measured a capacitor rated for 440volts, 50Hz where in measured capacitance value is as follows.

1. 197μf (between R & Y phase) -C_a

2. 196μf (between B & Y phase) -C_b

3. 200μf (between R & B phase) -C_c

$$Q_M = 2/3 \times (C_a + C_b + C_c) \times U_N^2 \times (2\pi f_N) / 10^9$$

$$Q_M = 2/3 \times (197+196+200) \times (440^2) \times 2 \times 3.14 \times 50 / 10^9 = 24.04\text{kvar}$$

2: Consider you have measured a capacitor rated for 480V ,60Hz where in measured capacitance value is as follows.

4. 236μf (between R & Y phase) - C_a

5. 238μf (between B & Y phase) - C_b

5. 237μf (between R & B phase) - C_c

$$Q_M = 2/3 \times (C_a + C_b + C_c) \times U_N^2 \times (2\pi f_N) / 10^9$$

$$Q_M = 2/3 \times (236+238+237) \times (480^2) \times 2 \times 3.14 \times 60 / 10^9 = 41.19\text{kvar}$$

The tolerance of capacitance of a capacitor is -5% to +10% of capacitor as specified in the IEC Standards.



VarSelect

Automatic Power Factor Correction
Bank Design Guide



Experience the power of digitization with VarSelect to build a simple and efficient PFC Bank

Experience our VarSelect with

- Online tool for “One shop stop” of components to build PFC Bank
- Easy sign up process for users where you can create, save, retrieve, reuse and rework the project
- Complete Bill of materials for Electrical components to build PFC Banks with Single Line diagram
- Design optimization to save time, space and cost
- Flexibility in selecting range, voltage etc to cover the global market

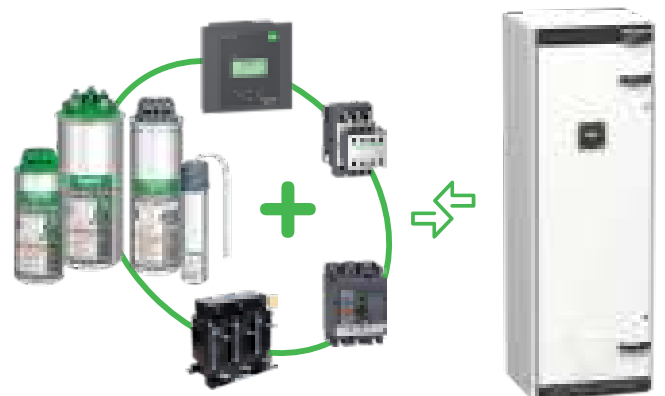

Discover more
about VarSelect....

Check your PFC Bank Design Guide!

varselect.schneider-electric.com

Life Is On

Schneider
Electric

Schneider Electric Industries SAS

Head Office

35, rue Joseph Monier

CS 3032392506 Rueil-Malmaison

www.schneider-electric.com

04-2018

PFCE1111008EN

As standards, specifications and designs change from time to time, please ask for confirmation of the information given in this publication.

 This document has been printed on ecological paper

Design: Schneider Electric
Photos: Schneider Electric

