



सत्यमेव जयते

भारत सरकार GOVERNMENT OF INDIA
रेल मंत्रालय MINISTRY OF RAILWAYS

केवल कार्यालयीन उपयोग हेतु
(For Official Use Only)



डीजल जनरेटर सेट (62.5 से 380 केवीए) के अनुरक्षण की
हस्तपुस्तिका

HANDBOOK ON MAINTENANCE of
DIESEL GENERATOR SETS
(62.5 TO 380 KVA)

लक्ष्य समूह : विद्युत सामान्य सेवा के अनुरक्षण कर्मचारी
TARGET GROUP : ELECTRICAL GENERAL SERVICES MAINTENANCE STAFF

कैमटेक ई 11-12 डीजी सेट 1.0
CAMTECH/ E/11-12/DG-Set/1.0

मार्च
March, 2012



अअमा संRDS
रेल अग्रदूत Transforming Railways
www.ards.gov.in



An ISO 9001:2008 Certified Organization
उच्च अनुरक्षण प्रौद्योगिकी केंद्र
Excellence In Maintenance

Indian Railways
Centre for Advanced Maintenance Technology

महाराजपुर, ग्वालियर – 474 005
Maharajpur, GWALIOR - 474 005

डीजल जनरेटर सेट (62.5 से 380 केवीए) के अनुरक्षण
की हस्तपुस्तिका

*HANDBOOK ON MAINTENANCE OF
DIESEL GENERATOR SETS
(62.5 TO 380 kVA)*

गुणवत्ता नीति

रेलों में यात्री और माल यातायात की बढ़ती माँग को पूरा करने के लिए गुणवत्ता प्रबंध प्रणाली में अनुसंधान, डिजाइनों और मानकों में उत्कृष्टता तथा सतत सुधारों के माध्यम से सांविधिक और नियामक अपेक्षाओं को पूरा करते हुए सुरक्षित, आधुनिक और किफायती रेल प्रौद्योगिकी का विकास करना ।

QUALITY POLICY

"To develop safe, modern and cost effective Railway Technology complying with Statutory and Regulatory requirements, through excellence in Research, Designs and Standards and Continual improvements in Quality Management System to cater to growing demand of passenger and freight traffic on the railways".

भूमिका

टंजन की लाइफ एवं इंजन को उत्तम परिचालन अवस्था में रखने के लिए अनुरक्षण अत्यन्त महत्वपूर्ण कारक होता है। मरम्मत सुधार की अपेक्षा सुनियोजित अनुरक्षण अधिक किफायती होता है। सुनियोजित अनुरक्षण इंजन की रोजाना की आरम्भिक अवस्था एवं प्रणाली से अवगत कराता है।

कैमटेक द्वारा डीजी सेट के अनुरक्षण पर यह हस्तपुस्तिका कर्मचारियों की जानकारी बढ़ाने एवं कार्यक्षेत्र में अपनायी जानेवाली अनुरक्षण तकनीकों से अवगत कराने के उद्देश्य से बनाई गई है।

इस हस्तपुस्तिका में डीजी सेट के विभिन्न उपकरणों का संक्षिप्त विवरण, संस्थापन के लिए मार्गदर्शन विभिन्न निर्माताओं के अनुरक्षण शेड्यूल, विश्वसनीयता बढ़ाने हेतु अनुरक्षण उपाय, एवं क्या करें , क्या न करें दिये गये हैं।

यह स्पष्ट किया जाता है कि यह हस्त पुस्तिका आरडीएसओ रेलवे बोर्ड/क्षेत्रीय रेलों या उपकरण निर्माता द्वारा विनिर्दिष्ट किसी भी विधान को विस्थापित नहीं करती। यह हस्तपुस्तिका केवल मार्गदर्शन हेतु है एवं यह एक वैधानिक दस्तावेज़ नहीं है।

मैं, आरडीएसओ/लखनऊ के विद्युत ऊर्जा प्रबन्धन निदेशालय का इस हस्तपुस्तिका को बनाने में मार्ग दर्शन करने एवं इसका अनुमोदन करने के लिए आभारी हूँ।

तकनीकी उन्नयनता और सीखना एक सतत् प्रक्रिया है अतः इस हस्तपुस्तिका में किसी भी प्रकार का संशोधन करने के लिये हमें लिखने में आप स्वतंत्र महसूस करें । इस दिशा में हम आपके योगदान की सराहना करेंगे।

कैमटेक, ग्वालियर
दिनांक 27, मार्च 2012

पीयूष गुप्ता
सं. निदेशक (विद्युत)

PREFACE

Maintenance is the most important factor for the operating life of the engine. Preventive Maintenance is more economical than corrective repairs. Preventive maintenance begins with a day to day awareness of the condition of the engine and its systems.

This handbook on maintenance of “Diesel Generator Sets” has been prepared by CAMTECH with the objective to disseminate knowledge among the maintenance personnel and making aware of maintenance techniques to be adopted in field.

This handbook includes brief description of various sub assemblies, installation guidelines, maintenance schedules for various makes, maintenance tips, and do’s & don’ts to improve reliability of DG sets.

Schedule instructions given in this handbook consist of work involved in various schedules so as to staff enable for better understanding. These instructions are for guidance only and for more details, please refer respective maintenance manual supplied with the DG set by OEM.

It is clarified that this handbook does not supersede any existing provisions laid down by RDSO/Zonal Railways or OEM. This handbook is for guidance only and it is not a statutory document.

I am sincerely thankful to EEM Directorate of RDSO/ Lucknow for guidance & approving the handbook.

Technological up-gradation & learning is a continuous process. Please feel free to write to us for any addition/modification in this handbook.

CAMTECH, Gwalior
Date: 27.03.2012

Peeyoosh Gupta
Jt. Director Electrical

विषय – सूची

क्रम सं.	विवरण	पृष्ठ क्रमांक
	भूमिका	iii
	विषय-सूची	v
	संशोधन पर्ची	xi
1	सामान्य विवरण	01
1.1	प्रस्तावना	01
1.2	चार स्ट्रोक डीजल इंजन का संचालन	01
1.3	डीजी सेट के विभिन्न अवयव	03
1.3.1	डीजल इंजन के अवयव	03
1.3.2	ईंधन टैंक	06
1.3.3	ऑल्टरनेटर	06
1.3.4	सहायक ऑल्टरनेटर	07
1.3.5	स्टार्टर मोटर	07
1.3.6	बैट्री	07
1.3.7	कन्ट्रोल पैनल	07
1.3.8	ध्वनिक घेरा (छतरी)	08
1.4	इंजन प्रणालियाँ	08
1.4.1	हवा प्रणाली	08
1.4.2	ईंधन प्रणाली	09
1.4.3	ल्यूब प्रणाली	09
1.4.4	शीतलन प्रणाली	10
1.5	डीजी सेट के लाभ	10
1.6	पैकेज (ध्वनिक घेरा) प्रकार के डीजी सेट के संस्थापन के लिए मार्गदर्शन	11
2	संचालन एवं अनुरक्षण	12
2.1	डीजी सेट के चालू करने के तरीके	12
2.1.1	पुश बटन स्टार्ट/हस्त तरीका	12
2.1.2	स्वतः चालू प्रणाली/ स्वतः तरीका	12
2.1.3	परीक्षण का तरीका	12
2.2	डीजी सेट को चालू करना	13
2.3	डीजी सेट को बंद करना	13
2.4	कोई भी खराबी आने से पहले की चेतावनी/ संकेत	13
2.5	सामान्य सुरक्षा निर्देश	14

2.6 निवारण/रोकथाम अनुरक्षण का महत्व
14

CONTENTS

Chapter	Description	Page No.
	<i>Preface</i>	<i>iv</i>
	<i>Contents</i>	<i>vi</i>
	<i>Correction Slip</i>	<i>xii</i>
1	GENERAL DESCRIPTION	01
1.1	INTRODUCTION	01
1.2	OPERATION OF FOUR STROKE DIESEL ENGINE	01
1.3	VARIOUS PART OF DG SET	03
1.3.1	Part of Diesel engine	03
1.3.2	Fuel Tank	06
1.3.3	Alternator	06
1.3.4	Auxiliary Alternator	07
1.3.5	Starter Motor	07
1.3.6	Battery	07
1.3.7	Control Panel	07
1.3.8	Acoustic Enclosure (Canopy)	08
1.4	ENGINE SYSTEMS	08
1.4.1	Air System	08
1.4.2	Fuel System	09
1.4.3	Lube System	09
1.4.4	Cooling System	10
1.5	ADVANTAGES OF DG SET	10
1.6	INSTALLATION GUIDE LINES FOR PACKAGE TYPE (ACOUSTIC ENCLOSURE) DG SET	11
2	OPERATION	12
2.1	MODES FOR STARTING DG SET	12
2.1.1	Push Button Start/ Manual Mode	12
2.1.2	Auto Starting System/ Auto Mode	12
2.1.3	Test Mode	12
2.2	STARTING OF DG SET	13
2.3	STOPPING OF DG SET	13
2.4	WARNINGS/ INDICATIONS BEFORE ANY FAILURE	13
2.5	GENERAL SAFETY INSTRUCTIONS	14
2.6	IMPORTANCE OF PREVENTIVE MAINTENANCE	14



क्रम सं.	विवरण	पृष्ठ क्रमांक
3.	ग्रीक्स के डीजल इंजनों का अनुरक्षण (डी3 सीरीज)	15
3.1	दैनिक अनुरक्षण	15
3.1.1	इंजन चालू होने के पहले	15
3.1.2	इंजन चालू होने के बाद	15
3.2	संस्थापन के बाद केवल पहले 30 घंटे होने पर अनुरक्षण	16
3.3	संस्थापन के बाद केवल पहले 60 घंटे होने पर अनुरक्षण	17
3.4	संस्थापन के बाद केवल पहले 125 घंटे होने पर अनुरक्षण	18
3.5	250 घंटे होने पर अनुरक्षण	19
3.6	500 घंटे होने पर अनुरक्षण	20
3.7	750 घंटे होने पर अनुरक्षण	21
3.8	1000 घंटे होने पर अनुरक्षण	22
3.9	1250 घंटे होने पर अनुरक्षण	23
3.10	1500 घंटे होने पर अनुरक्षण	24
3.11	1750 घंटे होने पर अनुरक्षण	25
3.12	2000 घंटे होने पर अनुरक्षण	26
4.	किलोसकर डीजल इंजनों का अनुरक्षण (एसएल 90 सीरीज)	28
4.1	अ-शैड्यूल (दैनिक अनुरक्षण)	28
4.2	संस्थापन के बाद केवल पहले 50 घंटे होने पर अनुरक्षण	28
4.3	ब-शैड्यूल (प्रत्येक 50 घंटे के बाइ अनुरक्षण)	30
4.4	सी-शैड्यूल (प्रत्येक 300 घंटे के बाइ अनुरक्षण)	30
4.5	डी-शैड्यूल (प्रत्येक 600 घंटे के बाइ अनुरक्षण)	31
4.6	ई-शैड्यूल (प्रत्येक 1200 घंटे के बाइ अनुरक्षण)	31
5.	क्यूमिन्स के डीजल इंजनों का अनुरक्षण (बी सीरीज)	32
5.1	ए-चैक (दैनिक अनुरक्षण)	32
5.2	बी-चैक (प्रत्येक 225-250 घन्टे या 6 माह इसमें जो पहले हो)	32
5.3	सी-चैक (प्रत्येक 475-500 घन्टे या 12 माह इसमें जो पहले हो)	32
5.4	डी-चैक (प्रत्येक 950-1000 घन्टे या 24 माह इसमें जो पहले हो)	34
6.	महीन्द्रा डीजल इंजनों का अनुरक्षण (पावर रोल)	35
6.1	चालू करने से नूर्व की जाँचें	35
6.3	इंजन को चालू करना	35
6.3	दैनिक जाँच	35
6.4	साप्ताहिक जाँच	35
6.5	प्रत्येक 300 घंटे या 3 माह (इसमें जो पहले हो) में अनुरक्षण	36
6.6	प्रत्येक 600 घंटे या 6 माह (इसमें जो पहले हो) में अनुरक्षण	37
6.7	1200 घंटे या 12 माह के बाद (इसमें जो पहले हो) अनुरक्षण	37

Chapter	Description	Page No.
3	MAINTENANCE OF GREAVES DIESEL ENGINE (D3 SERIES)	
15		
3.1	DAILY MAINTENANCE	15
	3.1.1 Before Starting the Engine	15
	3.1.2 After Starting the Engine	15
3.2	ONLY AT FIRST 30 HOURS MAINTENANCE AFTER COMMISSINING	16
3.3	ONLY AT FIRST 60 HOURS MAINTENANCE AFTER COMMISSINING	17
3.4	ONLY AT FIRST 125 HOURS MAINTENANCE AFTER COMMISSINING	18
3.5	250 HOURS MAINTENANCE	19
3.6	500 HOURS MAINTENANCE	20
3.7	750 HOURS MAINTENANCE	21
3.8	1000 HOURS MAINTENANCE	22
3.9	1250 HOURS MAINTENANCE	23
3.10	1500 HOURS MAINTENANCE	24
3.11	1750 HOURS MAINTENANCE	25
3.12	2000 HOURS MAINTENANCE	26
4.	MAINTENANCE OF KIRLOSKAR DIESEL ENGINE (SL90 SERIES)	28
4.1	A-SCHEDULE (DAILY MAINTENANCE)	28
4.2	ONLY AT FIRST 50 HOURS MAINTENANCE AFTER COMMISSINING	28
4.3	B-SCHEDULE (MAINTENANCE AFTER EVERY 50 HOURS)	30
4.4	C-SCHEDULE (MAINTENANCE AFTER EVERY 300 HOURS)	30
4.5	D-SCHEDULE (MAINTENANCE AFTER EVERY 600 HOURS)	31
4.6	E-SCHEDULE (MAINTENANCE AFTER EVERY 1200 HOURS)	31
5.	MAINTENANCE OF CUMMINS DIESEL ENGINES (B SERIES)	
32		
5.1	A-CHECK (Daily Maintenance)	32
5.2	B-CHECK (Every 225-250 Hrs or 6 Months Whichever is Earlier)	32
5.3	C-CHECK (Every 475-500 Hrs or 12 Months Whichever is Earlier)	33
5.4	D-CHECK (Every 950-1000 Hrs or 24 Months Whichever is Earlier)	34
6.	MAINTENANCE OF MAHINDRA DIESEL ENGINES (POWEROL)	35
6.1	PRE-STARTING CHECKS	35
6.2	STARTING THE ENGINE	35
6.3	DAILY CHECKS	35
6.4	WEEKLY CHECKS	35
6.5	MAINTENANCE EVERY 300 Hrs OR 3 MONTHS	36
6.6	MAINTENANCE EVERY 600 Hrs OR 6 MONTHS	37



7. क्या करें क्या न करें	39
7.1 सामान्य	39
7.1.1 क्या करें	39
7.1.2 क्या न करें	39
7.2 हवा प्रणाली	40
7.2.1 क्या करें	40
7.2.2 क्या न करें	40
7.3 इंधन प्रणाली	41
7.3.1 क्या करें	41
7.3.2 क्या न करें	41
7.4 शीतलन प्रणाली	41
7.4.1 क्या करें	41
7.4.2 क्या न करें	42
7.5 स्नेहन प्रणाली	42
7.5.1 क्या करें	42
7.5.2 क्या न करें	42
8. एफएक्यू (अक्सर पूछे जाने वाले प्रश्न)	43
संदर्भ	46

Chapter	Description	Page No.
7.	DO'S & DON'TS	39
7.1	GENERAL	39
	7.1.1 Do's	39
	7.1.2 Don'ts	39
7.2	AIR SYSTEM	40
	7.2.1 Do's	40
	7.2.2 Don'ts	40
7.3	FUEL SYSTEM	41
	7.3.1 Do's	41
	7.3.2 Don'ts	41
7.4	COOLING SYSTEM	41
	7.4.1 Do's	41
	7.4.2 Don'ts	42
7.5	LUBRICATION SYSTEM	42
	7.5.1 Do's	42
	7.5.2 Don'ts	42
8.	FAQs (FREQUENTLY ASKED QUESTIONS)	43
	REFERENCE	46

अध्याय 1 CHAPTER 1

सामान्य विवरण GENERAL DESCRIPTION

1.1 प्रस्तावना INTRODUCTION

The Diesel Generator set (diesel engine driven generating set) is a compact and robust machine in which mechanical energy is converted into electrical energy. It uses high speed diesel oil and works on diesel cycle. In this system the air is drawn into the cylinder and compressed to a high ratio (14:1 to 25:1). During this compression, the air is heated to a temperature of 700 – 900 deg. C. A metered quantity of diesel fuel is then injected into the cylinder, which ignites spontaneously because of the high temperature of compressed air. The diesel is injected through injector in the chamber. Hence, the diesel engine is also known as compression ignition (CI) engine.

An alternator is coupled with the diesel engine and the kinetic energy of engine is transmitted to alternator and converted into electrical energy. Alternator works on the Faraday's law of electromagnetic induction. This electrical energy is then fed to the load.

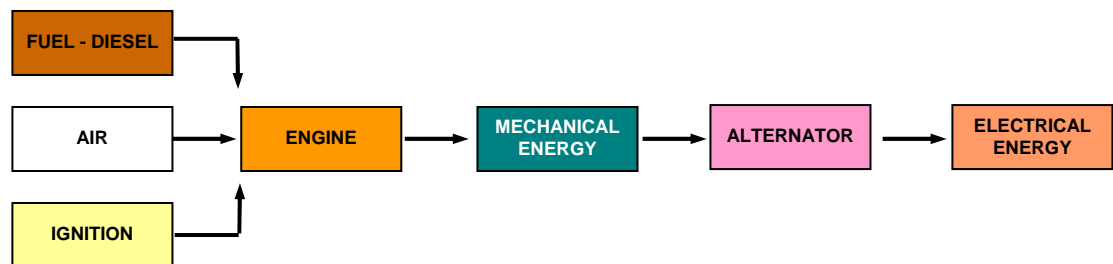

Figure 1.1 Flow diagram of working principle of DG set

DG set can be classified according to cycle type as: two strokes and four strokes. However, the commonly used diesel engines use the four stroke cycle.

1.2 चार स्ट्रोक डीजल इंजन का संचालन OPERATION OF FOUR STROKE DIESEL ENGINE

The 4 stroke operations in a diesel engine are as follows which take place in the individual cylinder:

a. सक्शन/इन्डक्सन स्ट्रोक Suction/Induction stroke

During this Suction/Induction stroke,

- Intake valve remains open during the entire intake stroke.
- Piston travels from TDC (top dead centre) to BDC (bottom dead centre).
- Due to partial vacuum created by the piston travel, air rushes in.
- Exhaust valve remains closed during this period



b. कम्प्रेसन स्ट्रोक Compression stroke

During this Compression stroke,

- Both inlet and exhaust valves remain closed.
- Piston travels from BDC to TDC.
- The entrapped air is compressed to a pressure of up-to 25 bar and causing air temperature to rise to above 560 °C.
- Fuel is injected in atomized condition in to the hot air where it ignites.
- Combustion of fuel generates heat and gases. The rapid rise in temperature and pressure in the combustion chamber pushes the piston to BDC.

Figure 1.2 Suction/Induction stroke

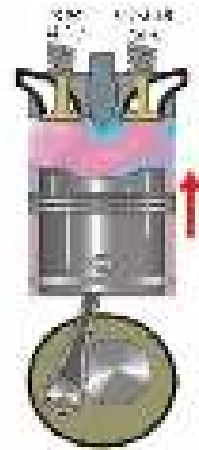

Figure 1.3 Compression stroke

c. पावर स्ट्रोक Power stroke

During this Power stroke,

- During this stroke both valves remain closed.
- Due to high temperature and pressure in the combustion chamber, piston is pushed from TDC to BDC.
- This is also called as "Useful Work Done".
- In this working stroke the connecting rod transmits the force to the rotating crankshaft.



Figure 1.4 Power stroke

d. एग्जॉस्ट स्ट्रोक Exhaust stroke

- Intake valve remains closed.
- Exhaust valve remains open during the entire stroke.
- Piston travels from BDC to TDC.
- Exhaust gases are expelled out from the cylinder to the atmosphere.



Figure 1.5 Exhaust stroke

1.3 डीजी सेट के विभिन्न अवयव VARIOUS PARTS OF DG SET

Diesel Generator set consists mainly following parts/assemblies:

- Diesel Engine
- Alternator
- Fuel Tank
- Auxiliary Alternator
- Starter Motor
- Battery
- Control Panel
- Acoustic Enclosure (Canopy)

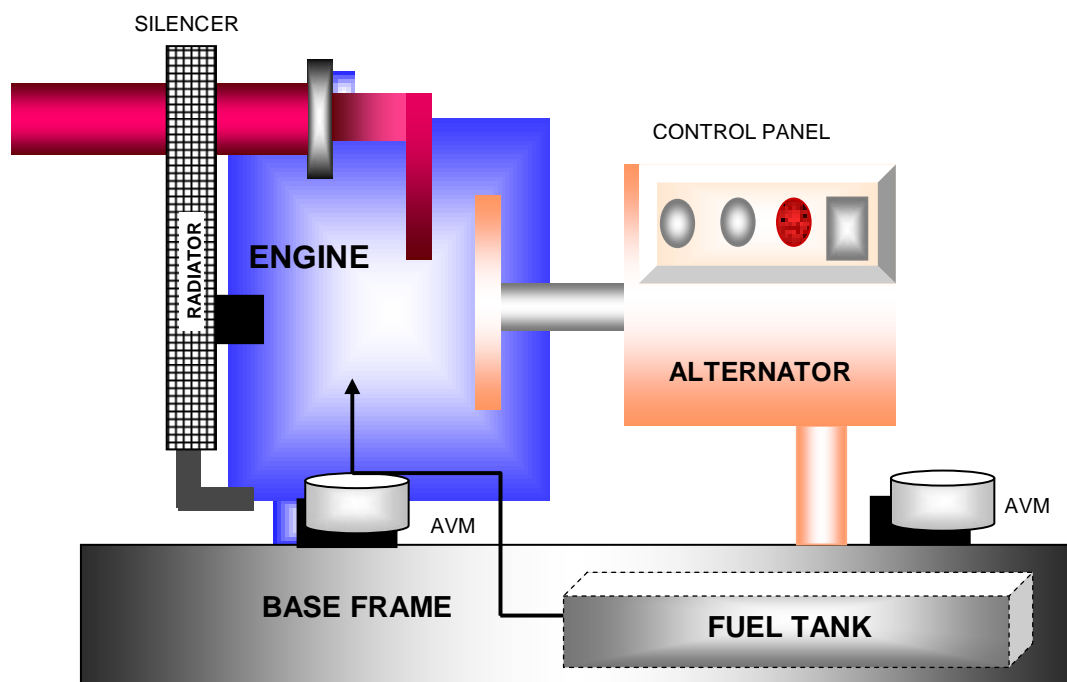

Figure 1.6 General layout of DG set

1.3.1 डीजल इंजन के अवयव Parts of a Diesel Engine

The Diesel Engine consists following main parts:

1.3.1.1 क्रैंक केस एवं ऑयल पैन Crankcase and oil pan

These two components form the load bearing housing of the engine. They absorb the forces occurring during operation in the cylinder and at the crank assembly. The crankcase accommodates the cylinder liners, the crank assembly and the camshaft.

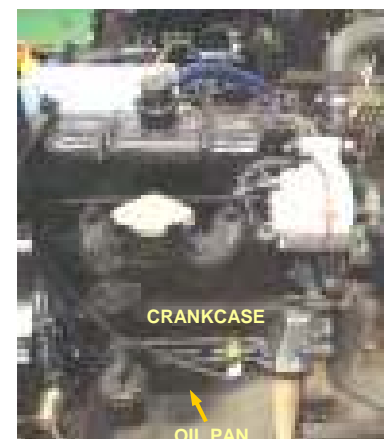

Figure 1.7

1.3.1.2 सिलेंडर हेड्स Cylinder Heads

A cylinder head closes the top end of the cylinder. It makes a confined space for compressed air and the gases. Each cylinder head contains the inlet and exhaust valves and fuel injection valve. For cooling of the valve seats and injection valve, coolant is piped through cooling chambers arranged in the cylinder head.



Figure 1.8

1.3.1.3 चालन यंत्र/ रचना Driving mechanism

The crank shaft is driven via the connecting rods by means of the gas acting on the pistons. The forces of the rotary masses at the individual crank throws are compensated by means of balance weights. The crank shaft provided rotation of the camshaft via gear drive and also rotates the injection pump drive.

The cams of the camshaft actuate inlet and exhaust valve via the push rod and rocker arm.

1.3.1.4 ईंधन पम्प, इन्जेक्शन पम्प, ईंधन प्रणाली Fuel Pump, injection pump and Fuel system

By means of fuel pump, the fuel is pumped from fuel tank into the injection pump via filter. By means of the injection nozzles the fuel is squirted very finely into the combustion chamber.



Figure 1.9

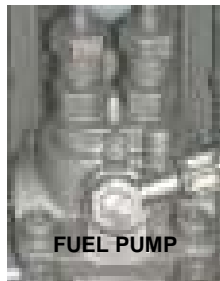

Figure 1.10

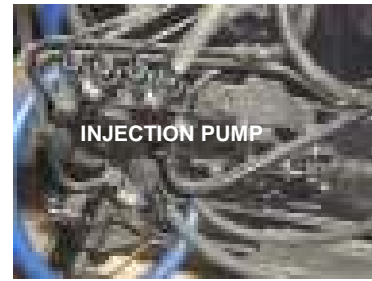

Figure 1.11

For the purpose of cooling the injection pumps more fuel than the required for injection through the system by the fuel feed pump. The surplus fuel is returned to the fuel tank via an over flow valve at the injection pump.

1.3.1.5 ल्यूब पम्प एवं प्रणाली Lube pump and system

The bearings and the cylinder liners are lubricated to reduce friction and to dissipate heat. The lube oil pump draws the lube oil from the oil pan and pumps to the points of lubrication through oil cooler and filter.



Figure 1.12

1.3.1.6 रेडियेटर एवं शीतलन प्रणाली Radiator and cooling system

The thermal energy generated during fuel combustion can only be partly converted into mechanical energy. The part of the residual heat is eliminated by means of cooling the combustion chamber walls by coolant. The heat absorbed by coolant is passed on to atmosphere by means of radiator and fan.



Figure 1.13

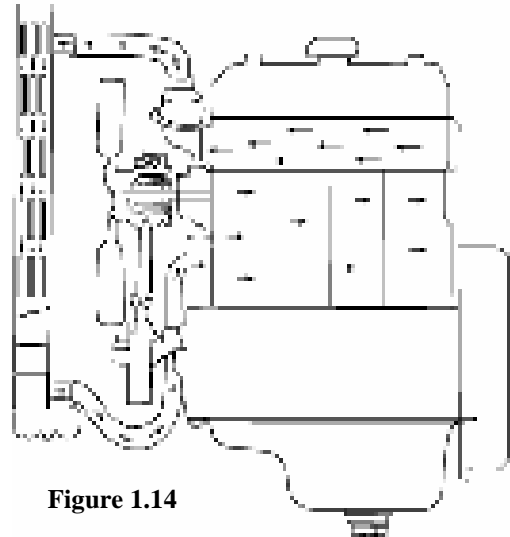

Figure 1.14

1.3.1.7 टर्बोचार्जर Turbocharger

The turbocharger is provided to increase the power output and efficiency of an engine by supplying compressed air to the engine intake manifold. The power to drive the turbocharger is expected from energy in the exhaust gases.

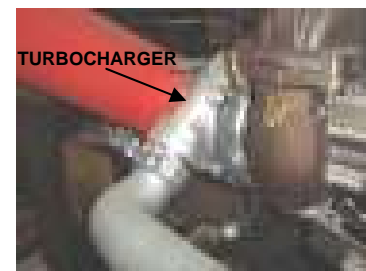

Figure 1.15

1.3.1.8 एग्जॉस्ट प्रणाली Exhaust System

Exhaust bellow connects engine and DG silencer to drive away hot gases generated during operation of DG to atmosphere through silencer. Exhaust muffler reduces noise level of the engine as per designed parameter and exhaust extension pipe, connected to DG silencer outlet ensures that the hot gases are driven out to atmosphere.



Figure 1.16

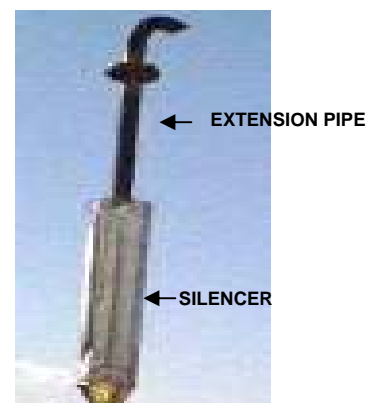

Figure 1.17

1.3.2 ईधन टैंक Fuel Tank

It stores Diesel required for operation of DG set. It consists *Fuel Level Float* which continuously monitors the level of Diesel available in tank and communicates fuel Gauge to provide indication. It also consists *Fuel Level Sensor* which senses level of fuel in fuel tank and communicates engine safety unit to provide alarm or stopping of DG as per designed operating levels.



Figure 1.18



Figure 1.19



Figure 1.20

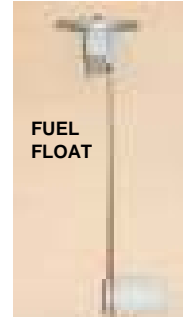

Figure 1.21

1.3.3 ऑल्टरनेटर Alternator



Figure 1.22

A self excited, self regulated brushless type alternator is coupled directly with engine by means of flexible coupling. The alternator is designed for specified kVA rating in single/three phase at 230V/415V, 50 Hz, 1500 rpm and power factor 0.8 lagging. It is dynamically balanced and can withstand speed upto 20% in excess of the rated speed.

Following are the main parts of an Alternator:

- Stator
- Rotor
- Automatic Voltage Regulator (AVR)
- Terminal Box
- DE Adaptor
- Slotted Surround
- NDE Shield

1.3.4 सहायक ऑल्टरनेटर Auxiliary Alternator

Auxiliary alternator is a machine that converts mechanical energy to electrical energy and its output is used to charge the battery. The inbuilt rectifier converts the A.C output to D.C.

The inbuilt Regulator controls the output and it depends on the battery charge status



Figure 1.23

1.3.5 स्टार्टर मोटर Starter Motor

A Starter motor is a machine that converts electrical energy to mechanical energy. Its output is used to crank the engine. Starter motor gets supply from the battery. When the Starter solenoid switch getting energized, the pinion engages with the flywheel ring gear and rotates the same.

The starter performance depends on the battery charge status and the voltage drop in the starting circuit.

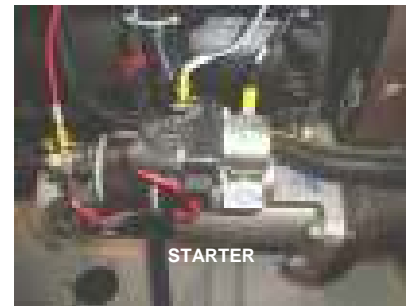

Figure 1.24

1.3.6 बैट्री Battery

The battery is provided to feed the supply to the starter for cranking/ starting the DG set. A 12 V Low Maintenance/Maintenance Free lead acid battery for DG sets upto 125 kVA capacity and 24 V battery for DG sets above 140 kVA capacity is required.

It also provides DC Power to engine safety unit and gauges.

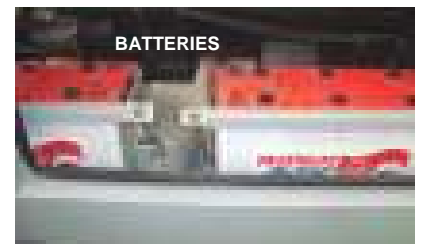

Figure 1.25

1.3.7 कन्ट्रोल पैनल Control Panel

This panel houses various electrical switchgears and controls such as Hour meter, Switches used for starting and stopping of DG and other electrical components which facilitates the following:

- Enable transfer of DG AC output to loads.
- Monitor performance of DG through Measuring instruments and Gauges.
- Engine related gauges and controls:
 - + Engine oil pressure gauge
 - + Water Temperature gauge
 - + Engine oil temperature gauge
 - + Tachometer / Hour meter
 - + Oil level gauge
 - + Vacuum Indicator
 - + Fuel level indicator
 - + Air pressure gauge



Figure 1.26

1.3.8 ध्वनिक घेरा (छतरी) Acoustic Enclosure (Canopy)

The complete DG set is housed in a modular type acoustic enclosure to control noise from the DG set. This enclosure is fabricated with 2mm CRCA (Cold Rolled Carbon Annealed) sheet. The noise level shall be 75 dBA or better at a 1 meter from the acoustic enclosure surface conforming to environmental (protection) rules issued by CPCB (Central Pollution Control Board), Government of India.

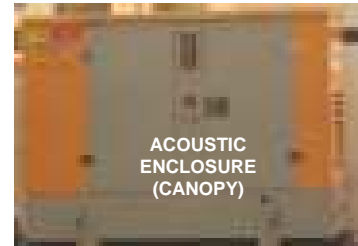

Figure 1.27

1.4 इंजन प्रणालियाँ ENGINE SYSTEMS

There are four principle engine systems such as Air, Fuel, Lubrication & Cooling system. Good understanding of engine systems will help in preventive maintenance and troubleshooting.

1.4.1 हवा प्रणाली Air System

Air enters through air cleaner (filter) to turbocharger inlet. Turbocharged air passes through intake manifold, gets distributed to all power cylinders. After combustion, burnt gases go out through exhaust manifold & rotate the turbine wheel. Exhaust gases emit out through flexible bellow & muffler.

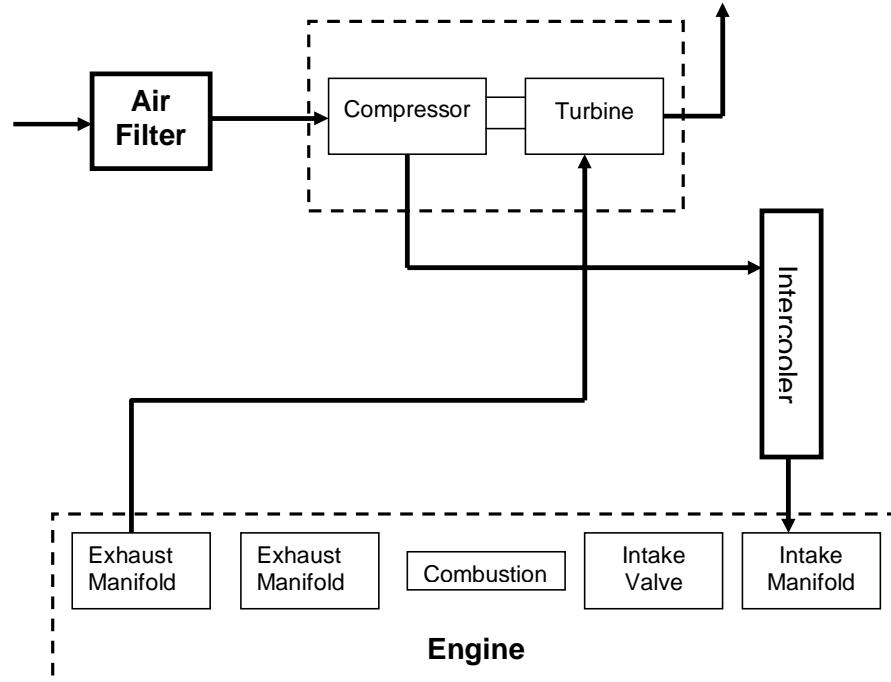

Figure 1.28 Air System

1.4.2 ईधन प्रणाली Fuel System

Fuel is sucked from base (fuel) tank by suction inlet pipe and suction strainer. Lift pump (feed pump) lifts the fuel & delivers to the filtration system. There are two stages of fuel cleaning; once by water-separator & then by micro-fine fuel filter.

Cleaned fuel enters to fuel injection pump which pressurise and delivers the high pressured fuel to fuel injectors fitted on each cylinder. Returned fuel is routed back to the tank through return pipe.

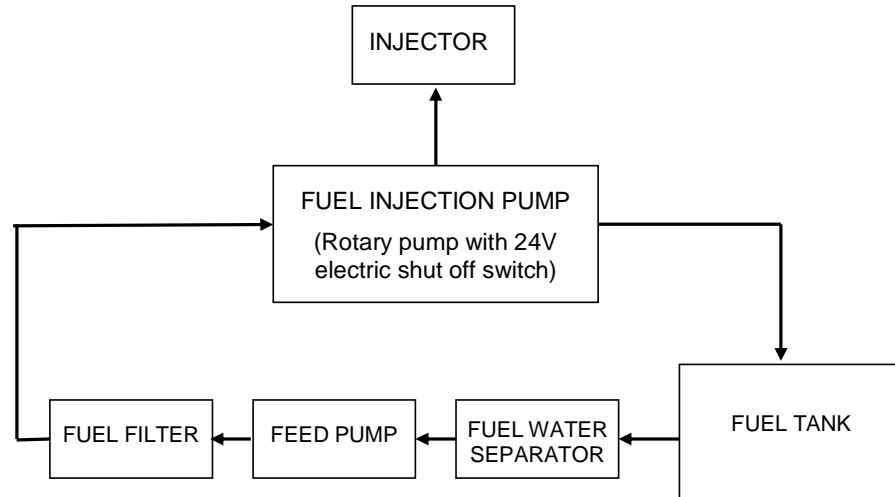

Figure 1.29 Fuel System

1.4.3 ल्यूब प्रणाली Lube system

Lubricating pump draws oil from the oil pan & forces it to the lubrication system. The pressure regulating valve controls oil pressure. The filter bypass valve ensures supply of oil when filter gets choked. The piston pins are lubricated by the splash from piston cooling nozzles. Oil pump idler gear is forced lubricated. The remainder of the front gear train is lubricated by oil carry over splash.

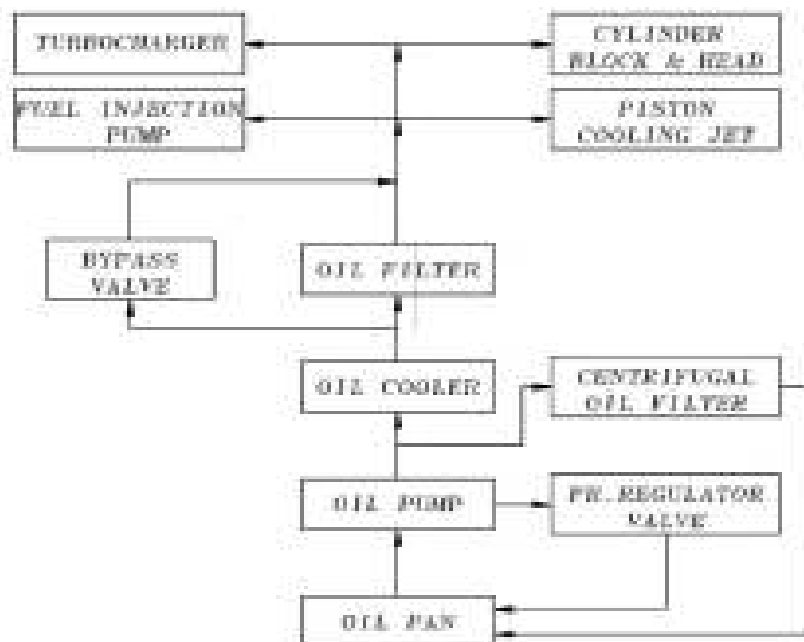

Figure 1.30 Lube System

1.4.4 शीतलन प्रणाली Cooling System

Coolant is sucked by the engine driven water pump from the bottom tank of the radiator. Coolant passes through oil cooler, all cylinder jackets and cylinder heads to reach finally at thermostat housing. Coolant get divided either to the inlet of the water pump or to the radiator depending on coolant temperature. Complete coolant gets diverted to the radiator after coolant temperature reached to thermostat setting.

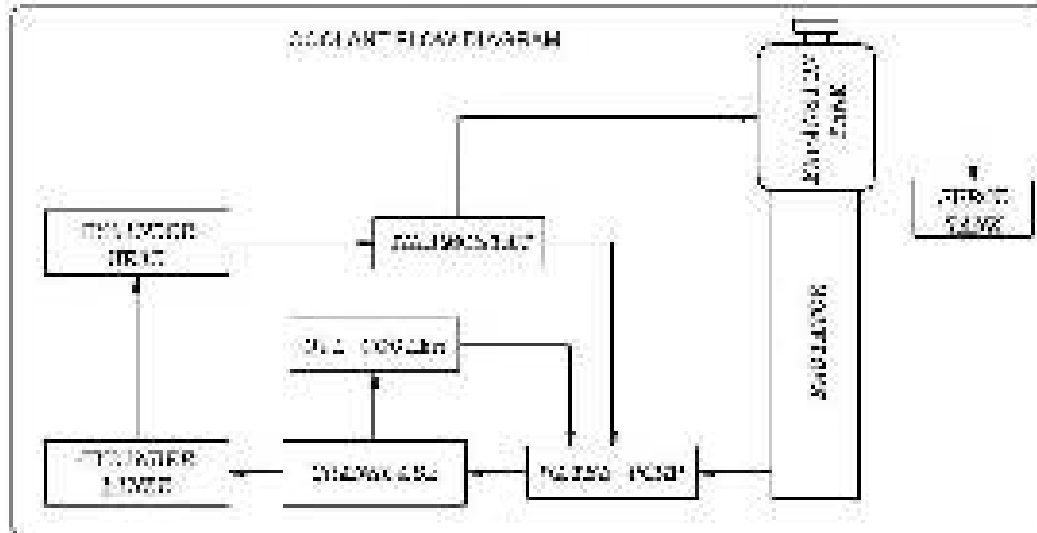

Figure 1.31 Cooling System

1.5 डीजी सेट के लाभ ADVANTAGES OF DG SET

Following are the advantages of DG set:

- It can start quickly and requires less period for warming.
- No stand by losses.
- Requires less manpower for running.
- Requires less maintenance.
- Wearing out parts of DG sets are easily replaceable.
- Life of DG set can be extended easily and economically.
- DG set can be easily located near the load hence requiring less expenditure for inter connection.
- Sets of varying sizes and of small capacities are available.
- Requires less space and building layout is simple.
- Automatic starting of set makes it possible to reduce periods of power supply interruption.
- Fuel handling and storage is easy.
- Uniformly high efficiency for all sizes.
- It can be procured and installed quickly and easily.

1.6 पैकेज (ध्वनिक घेरा) प्रकार के डीजी सेट के संस्थापन के लिए मार्गदर्शन INSTALLATION GUIDELINES FOR PACKAGE TYPE (ACOUSTIC ENCLOSURE) DG SET

It is recommended to follow the following installation guidelines or as recommended by DG set manufacturer which is to be installed:

- Proper lifting arrangement for loading & unloading of DG set without damaging the canopy panels shall be possible.
- Proper space should be available for loading & unloading of DG set on site.
- Acoustic enclosure should be placed in such a way, that all side doors can be opened fully without any obstruction. (1 to 1.5 meter of free space around the DG set)
- Avoid placement of enclosure, very close to side walls or pillars.
- Ensure there is no restriction on fuel tank removal side.
- Ensure proper height of base.
- Utmost care regarding safety should be taken when acoustic enclosure is placed on roof/ top of multistory building.
- Engine maintenance should be possible easily & freely, without dismantling acoustic enclosure.
- Ensure temperature rise inside the enclosure should not be more than 5-7 degree centigrade, above ambient temperature.
- Ensure visibility of engine control panel from outside of enclosure.
- Ensure proper earthing of the DG set.



Figure 1.32

The Importance of proper installation is to

- Reduce vibration in DG / reduced transmission
- Improve reliability & durability and Life
- Easy serviceability
- Optimum availability
- Better fuel economy
- Better working conditions
- Better sound absorption as per CPCB Norms
- Protection to environment by reduction in noise & emission of exhaust gases.

अध्याय 2 CHAPTER 2

संचालन एवं अनुरक्षण **OPERATION AND MAINTENANCE**

2.1 डीजी सेट के चालू करने के तरीके **MODES FOR STARTING DG SET**

The following procedures are adopted for starting diesel generator set using battery.

- Push button (Manual)
- Auto start (Auto)
- Test mode (For testing purpose)

The mode of operation can be selected by means of selector switch.

2.1.1 पुश बटन स्टार्ट / हस्त तरीका **Push Button Start/ Manual mode**

After pressing the start push button and turning the ignition key toward start position, the battery is connected to the starter which cranks the engine shaft resulting in the start of the engine. This arrangement can also be provided in small DG sets. This requires least physical efforts to start DG set. To prevent damage to the starter, do not push the start button for more than 10 to 12 seconds.

2.1.2 स्वतः चालू प्रणाली / स्वतः तरीका **Auto Starting System/ Auto mode**

This method is adopted where the supply from the generator is regularly required. In this mode, the DG set starts automatically in case of (i) mains failure, (ii) low/high mains voltage beyond 150-250 V for single phase DG set and 360-460 V for 3 phase DG set (iii) single phasing or phase reversal of main supply. When the engine starts, and alternator reaches the preset voltage, the DG contactor closes and automatically restores the supply to the load.

The auto start system makes three attempts to start, in case it fails to start, the starting system automatically disconnected and locked out. After restoration of healthy mains voltage, the DG contactor opens and main supply extended to the load. However the DG set continuous to run for 3 minutes and shutdown after that if mains supply remain stable.

During the above mentioned 3 minutes, if the mains fail again, the DG shutdown sequence discarded and the DG contactor closes again to restore the DG supply to the load.

2.1.3 परीक्षण का तरीका **Test mode**

In this mode all functions are likely to manual mode but DG supply can not be transferred to load. This mode is provided for the purpose of testing the DG set.

2.2 डीजी सेट को चालू करना STARTING OF DG SET

Before starting the engine, perform daily maintenance checks. Follow the instructions given below for reliable operation:

- To prevent damage to the starter, **do not push the start button** for more than 10 to 12 seconds. Wait for at least **2 minutes** between each attempt to start.
- If the engine does not start after three attempts, check the fuel supply system and fuel level in fuel tank. Absence of blue or white exhaust smoke during cranking indicates that no fuel is being delivered.
- Move the ignition key from start position to idle as soon as the engine starts.
- Monitor the oil pressure and coolant temperature gauges frequently.

2.3 डीजी सेट को बंद करना STOPPING OF DG SET

- Remove the load from the engine.
- Run the engine few minutes (3 to 5 minutes) before routine shut down on no load. It will allow the lubricating oil and coolant to carry heat away from the combustion chamber, bearings, shafts etc.
- Shut off the engine if oil pressure or coolant temperature is exceeding the specified limits.
- Avoid continuous operation of the engine with low or high coolant temperature, it may damage the engine.

2.4 कोई भी खराबी आने से पहले की चेतावनी/ संकेत WARNINGS/ INDICATIONS BEFORE ANY FAILURE

Most failures give an early warning. **Look and listen** for changes in **performance, sound or engine appearance** that can indicate service or engine repair is needed. Some changes to look for are as follows:

- Engine misfires
- Vibration
- Unusual engine noise
- Fuel, oil or coolant leakage
- Sudden change in engine operating temperature or oil pressure
- Excessive smoke
- Loss of power
- An increase in lube oil consumption
- An increase in fuel consumption

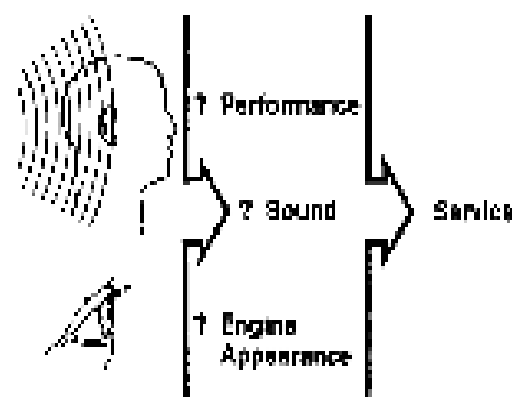

Figure 2.1

2.5 सामान्य सुरक्षा निर्देश **GENERAL SAFETY INSTRUCTIONS**

Improper practices or carelessness can cause burns, cuts, mutilation or other bodily injury or death. Read & understand safety precautions and warnings before performing operation, any repair/maintenance.

- Do not wear loose clothing.
- Always wear protective glasses and protective shoes while working on the engine.
- Ensure that the work area surrounding the DG set is dry, well illuminated, ventilated and spacious.
- Ensure that the work area surrounding the DG set is free from loose tools, parts, ignition sources and hazardous substances.
- Rotating parts can cause cuts, injury or strangulation.
- Disconnect the battery (-ve) cable first and discharge before beginning any repair work.
- Use only the proper engine barring techniques for manually rotating the engine. Do not attempt to rotate the crankshaft by pulling or prying the fan. This practice can cause serious personal injury, property damage or damage to fan blades.
- If the engine has been operating and the coolant is hot, allow the engine to cool before you slowly loosen the filler cap and relieve the pressure from the cooling system.
- Do not work on anything that is supported only by lifting jacks or a hoist. Always use blocks or proper stands to support the job before performing any maintenance work.
- Be alert for possible pressure when disconnecting any device from a system that utilizes pressure. Do not check for pressure leaks with your hand. High pressure oil or fuel can cause serious injury.
- Corrosion inhibitor contains alkali. Do not get the substance in your eyes. Avoid prolonged or repeated contact with your skin. Do not swallow internally. In case of contact, immediately wash skin with soap and water.
- To avoid burns, be alert for hot parts and hot fluids in lines, tubes and compartments.
- Always use tools that are in good condition. Use only genuine OEM replacement parts.
- Do not use fasteners of lesser quality if replacements are necessary.
- Avoid inhalation of vapour, ingestion and prolonged contact with used engine oil.

2.6 निवारण/रोकथाम अनुरक्षण का महत्व **IMPORTANCE OF PREVENTIVE MAINTENANCE**

Maintenance is the most important factor for both the life and keeping the engine in the best operating conditions. Preventive Maintenance is more economical than corrective repairs. It begins with a day to day awareness of the condition of the engine and its systems. For trouble free operation of DG set, it is recommended to carry out all necessary preventive maintenance, adjustments etc.. This will ensure reliable standby supply in case of failure of mains supply or as and when required.

In this handbook schedule instructions for few make DG sets are given for guidance of users and for more details, please refer respective maintenance manual supplied with the DG set by OEM. It is also recommended that a detailed logbook giving full parameters of the engine working, maintenance carried out etc. should be maintained for individual DG set.

अध्याय 3 CHAPTER 3

ग्रीव्स के डीजल इंजनों का अनुरक्षण (डी3 सीरीज) MAINTENANCE OF GREAVES DIESEL ENGINES (D3 SERIES)

3.1 दैनिक अनुरक्षण DAILY MAINTENANCE

3.1.1 इंजन चालू होने के पहले Before Starting the Engine

- i. Check and correct cooling water level.
- ii. Check belt tensions.
- iii. Clean radiator fins by blowing air in the opposite direction.
- iv. Check lube oil level, top up if required with same brand and grade of oil.
- v. Check oil level of oil bath filter and clean air cleaner as required.
- vi. Check clamping, tighten if required.
- vii. Drain once 200 ml. of diesel from bottom of fuel tank to remove sediments.
- viii. Check and ensure sufficient quantity of fuel in tank.
- ix. Check battery terminals and connections for proper tightness – top up electrolyte, if required.
- x. Clean engine and premises.

3.1.2 इंजन चालू होने के बाद After Starting the Engine

- i. Check lube oil pressure.
- ii. Check and attend leakages, if any.
- iii. Check all meters, engine noise etc. and correct abnormalities, if any.
- iv. Check engine protection systems.

**3.2 संस्थापन के बाद केवल पहले 30 घंटे होने पर अनुरक्षण
ONLY AT FIRST 30 HOURS MAINTENANCE AFTER COMMISSIONING**

Date of commissioning.....

Actual Date

**Expected date of
30 hours maintenance:**

Actual Hours

Sn.	Proposed Maintenance	Work Involved	Remarks
1.	Retorquing of cylinders head.	<ul style="list-style-type: none"> • Stop engine after warming up-to operating temperature. • Retorque all cylinders head bolts in cross wise pattern to 20-22 daNm (Mkp) uniformly on all cylinder heads. 	
2.	Retorquing of all fitments on exhaust side & turbochargers.	Retorque all fitments on exhaust side & turbochargers.	
3.	Resetting of valve clearances	<ul style="list-style-type: none"> • This shall be done on cold engine. • Remove cylinder head covers. • Check valve clearance between rocker arms and valve stem end with filler gauge as per the valve setting sequence. 	0.3mm for inlet valve and 0.5mm for exhaust valve
4.	Functioning of engine safety devices.	Check functioning of engine safety devices.	

3.3 संस्थापन के बाद केवल पहले 60 घंटे होने पर अनुरक्षण ONLY AT FIRST 60 HOURS MAINTENANCE AFTER COMMISSIONING

Date of commissioning..... Actual Date

Expected date of
60 hours maintenance: Actual Hours

S.N.	Proposed Maintenance	Work Involved	Remarks
1.	Changing of engine oil and filter cartridges.	<ul style="list-style-type: none"> • Warm up engine and stop. • Drain engine oil. • Remove engine oil filter cartridges and clean lube oil centrifuge. • Remove sump bottom cover and clean engine oil suction strainer. • Replace screw plugs with new seals. • Fill the recommended new engine oil to 'H' mark on dipstick. • Clean seal seat and oil seat of new filter cartridge slightly. • Fill the new filter element with fresh oil up to full and tighten it to filter head quickly. • Screw filter cartridge until seal contacts and then tighten manually (do not use tools). • Crank the engine without starting until engine oil pressure is indicated while the manual stopping device is to be maintained in stop position. • Check and top up oil level. • Start the engine and check leakage if any. 	<p>Recommended lube oil</p> <p>API CF-4 or equivalent (SAE15W40)</p> <p>Castrol RX super plus 15W-40</p> <p>IND-MOBIL DELVAC 1300 15W-40</p> <p>MOTUL HP4D 15W-40</p>
2.	Tightness of nuts and bolts.	<ul style="list-style-type: none"> • Check exhaust manifold bolts tightness. • Check foundation bolts & AVM. 	
3.	Record engine parameters.	<ul style="list-style-type: none"> • LOP (Lube oil pressure) • LOT (Lube oil temperature) • WT (Water temperature) • Amps. • Volts • kW 	
4.	Engine protection devices.	Check functioning of engine protection devices.	

3.4 संस्थापन के बाद केवल पहले 125 घंटे होने पर अनुरक्षण ONLY AT FIRST 125 HOURS MAINTENANCE AFTER COMMISSIONING

Date of commissioning.....

Actual Date

Expected date of

125 hours maintenance:

Actual Hours

S.N.	Proposed Maintenance	Work Involved	Remarks
1.	Changing of engine oil and filter cartridges.	Refer item no. 1 of first 60 Hours schedule.	
2.	Cleaning of air filter	<ul style="list-style-type: none"> • Clean choked air filters. • For wet air filters & oil bath filters, wash them in diesel. Do not use water for cleaning. • For dry air filters, clean them with compressed air from inside. Do not beat the filter element for cleaning 	
3.	Checking of V-belt, drive and tightness of nuts & bolts.	<ul style="list-style-type: none"> • The V-belt tension can be checked by pressing with thumb it shall be 1-2 cm. If it is not correct, readjustment shall be done. • Crank the engine for checking the V-belt all over for any sign of crack/wear. • Check tightness of all nuts and bolts. 	Tensioning the V-belt excessively aggravates wear just as much as slack V-belts.
4.	Grease of raw water pump	<ul style="list-style-type: none"> • Fill the grease nipples by means of grease gun. 	Multi purpose grease
5.	Greasing of generator (auxiliary) (as applicable)	<ul style="list-style-type: none"> • Lubricate the both ends ball bearings of the rotor. 	Bosch no. Ft 1 v 34 grease

3.5 250 घंटे होने पर अनुरक्षण 250 HOURS MAINTENANCE

Expected date of 250 hours maintenance:

Actual Date

Actual Hours

S.N.	Proposed Maintenance	Work Involved	Remarks
1..	Changing of engine oil and filter cartridges.	Refer item no. 1 of first 60 Hours schedule.	
2.	Cleaning of air filter	Refer item no. 2 of first 125 Hours schedule.	
3.	Checking of V-belt, drive and tightness of nuts & bolts.	Refer item no. 3 of first 125 Hours schedule.	
4.	Greasing of generator (auxiliary) (as applicable)	Refer item no. 5 of first 125 Hours schedule.	
5.	Checking of air and water hose piping.	Check air and water hose piping for any crack / leakage. Replace if required.	
6.	Checking of zinc protective plugs. (As applicable)	<ul style="list-style-type: none"> • Zink coated protective plugs are provided in the cooling water and raw water circuits to avoid destruction of the walls due to corrosion. Remove these plugs and check condition. If heavily decomposed, renew them. • Also replace copper washers with new. 	
7.	Checking of coupling disc of fuel pump drive.	Check coupling disc of fuel pump drive for any looseness.	
8.	Lubricating of raw water pump.	Fill the grease nipples by means of grease gun.	Multipurpose grease
9.	Checking & resetting of valve clearances.	Check & reset of valve clearances. (Refer item no. 3 of first 30 Hours schedule).	
10.	Checking of speed governor and engine shut down.	Check the function of speed governor and engine shut down by operating manually.	
11.	Checking of battery	<ul style="list-style-type: none"> • Clean and check the battery connections. • Check the electrolyte level and topup with distilled water if required. • Check the Specific Gravity of the electrolyte. If it is less than 1210gm/l, recharge the battery. 	
12.	Checking of engine safety devices.	Check proper functioning of engine safety devices.	

3.6 500 घंटे होने पर अनुरक्षण 500 HOURS MAINTENANCE

Expected date of 500 hours maintenance:

Actual Date

Actual Hours

S.N.	Proposed Maintenance	Work Involved	Remarks
1.	Changing of engine oil and filter cartridges.	Refer item no. 1 of first 60 Hours schedule.	
2.	Cleaning of air filter	Refer item no. 2 of first 125 Hours schedule.	
3.	Checking of V-belt, drive and tightness of nuts & bolts.	Refer item no. 3 of first 125 Hours schedule.	
4.	Greasing of generator (auxiliary) (as applicable)	Refer item no. 5 of first 125 Hours schedule.	
5.	Checking of air and water hose piping.	Refer item no. 5 of 250 Hours schedule.	
6.	Checking of zinc protective plugs. (As applicable)	Refer item no. 6 of 250 Hours schedule.	
7.	Checking of coupling disc of fuel pump drive.	Refer item no. 7 of 250 Hours schedule.	
8.	Lubricating of raw water pump.	Fill the grease nipples by means of grease gun.	Multipurpose grease
9.	Checking & resetting of valve clearances.	Check & reset of valve clearances. (Refer item no. 3 of first 30 Hours schedule).	
10.	Checking of speed governor and engine shut down.	Check the function of speed governor and engine shut down by operating manually.	
11.	Checking of battery	Refer item no. 11 of 250 Hours schedule.	
12.	Checking of engine safety devices.	Check proper functioning of engine safety devices.	
13.	Record engine parameters	<ul style="list-style-type: none"> • LOP (Lube oil pressure) • LOT (Lube oil temperature) • WT (Water temperature) • Amps. • Volts • kW 	
14.	Lubrication of starter	Lubricate starter as recommended.	

3.7 750 घंटे होने पर अनुरक्षण 750 HOURS MAINTENANCE

Expected date of 750 hours maintenance:

Actual Date

Actual Hours

S.N.	Proposed Maintenance	Work Involved	Remarks
1.	Changing of engine oil and filter cartridges.	Refer item no. 1 of first 60 Hours schedule.	
2.	Cleaning of air filter	Refer item no. 2 of first 125 Hours schedule.	
3.	Checking of V-belt, drive and tightness of nuts & bolts.	Refer item no. 3 of first 125 Hours schedule.	
4.	Greasing of generator (auxiliary) (as applicable)	Refer item no. 5 of first 125 Hours schedule.	
5.	Checking of air and water hose piping.	Refer item no. 5 of 250 Hours schedule.	
6.	Checking of zinc protective plugs. (As applicable)	Refer item no. 6 of 250 Hours schedule.	
7.	Checking of coupling disc of fuel pump drive.	Refer item no. 7 of 250 Hours schedule.	
8.	Lubricating of raw water pump.	Fill the grease nipples by means of grease gun.	Multipurpose grease
9.	Checking & resetting of valve clearances.	Check & reset of valve clearances. (Refer item no. 3 of first 30 Hours schedule).	
10.	Checking of speed governor and engine shut down.	Check the function of speed governor and engine shut down by operating manually.	
11.	Checking of battery	Refer item no. 11 of 250 Hours schedule.	
12.	Checking of fuel pump and camshaft gear cap screws.	Check proper functioning of fuel pump. Check tightness of camshaft gear cap screws.	
13.	Checking of engine safety devices.	Check proper functioning of engine safety devices.	
14.	Record engine parameters	<ul style="list-style-type: none"> • LOP (Lube oil pressure) • LOT (Lube oil temperature) • WT (Water temperature) • Amps. • Volts • kW 	
15.	Engine protection devices.	Check functioning of engine protection devices.	

3.8 1000 घंटे होने पर अनुरक्षण 1000 HOURS MAINTENANCE

Expected date of 1000 hours maintenance:

Actual Date

Actual Hours

S.N.	Proposed Maintenance	Work Involved	Remarks
1.	Changing of engine oil and filter cartridges.	Refer item no. 1 of first 60 Hours schedule.	
2.	Cleaning of air filter	Refer item no. 2 of first 125 Hours schedule.	
3.	Checking of V-belt, drive and tightness of nuts & bolts.	Refer item no. 3 of first 125 Hours schedule.	
4.	Greasing of generator (auxiliary) (as applicable)	Refer item no. 5 of first 125 Hours schedule.	
5.	Checking of air and water hose piping.	Refer item no. 5 of 250 Hours schedule.	
6.	Checking of zinc protective plugs. (As applicable)	Refer item no. 6 of 250 Hours schedule.	
7.	Checking of coupling disc of fuel pump drive.	Refer item no. 7 of 250 Hours schedule.	
8.	Lubricating of raw water pump.	Fill the grease nipples by means of grease gun.	Multipurpose grease
9.	Checking & resetting of valve clearances.	Check & reset of valve clearances. (Refer item no. 3 of first 30 Hours schedule).	
10.	Checking of speed governor and engine shut down.	Check the function of speed governor and engine shut down by operating manually.	
11.	Checking of battery	Refer item no. 11 of 250 Hours schedule.	
12.	Checking of engine safety devices.	Check proper functioning of engine safety devices.	
13.	Checking of turbocharger bearing clearances.	Check turbocharger bearing clearances.	
14.	Record engine parameters	<ul style="list-style-type: none"> • LOP (Lube oil pressure) • LOT (Lube oil temperature) • WT (Water temperature) • Amps. • Volts • kW 	
15.	Lubrication of starter	Lubricate starter as recommended.	

3.9 1250 घंटे होने पर अनुरक्षण 1250 HOURS MAINTENANCE

Expected date of 1250 hours maintenance:

Actual Date

Actual Hours

S.N.	Proposed Maintenance	Work Involved	Remarks
1.	Changing of engine oil and filter cartridges.	Refer item no. 1 of first 60 Hours schedule.	
2.	Cleaning of air filter	Refer item no. 2 of first 125 Hours schedule.	
3.	Checking of V-belt, drive and tightness of nuts & bolts.	Refer item no. 3 of first 125 Hours schedule.	
4.	Greasing of generator (auxiliary) (as applicable)	Refer item no. 5 of first 125 Hours schedule.	
5.	Checking of air and water hose piping.	Refer item no. 5 of 250 Hours schedule.	
6.	Checking of zinc protective plugs. (As applicable)	Refer item no. 6 of 250 Hours schedule.	
7.	Checking of coupling disc of fuel pump drive.	Refer item no. 7 of 250 Hours schedule.	
8.	Lubricating of raw water pump.	Fill the grease nipples by means of grease gun.	Multipurpose grease
9.	Checking & resetting of valve clearances.	Check & reset of valve clearances. (Refer item no. 3 of first 30 Hours schedule).	
10.	Checking of speed governor and engine shut down.	Check the function of speed governor and engine shut down by operating manually.	
11.	Checking of battery	Refer item no. 11 of 250 Hours schedule.	
12.	Checking of engine safety devices.	Check proper functioning of engine safety devices.	
13.	Record engine parameters	<ul style="list-style-type: none"> • LOP (Lube oil pressure) • LOT (Lube oil temperature) • WT (Water temperature) • Amps. • Volts • kW 	

3.10 1500 घंटे होने पर अनुरक्षण 1500 HOURS MAINTENANCE

Expected date of 1500 hours maintenance:

Actual Date

Actual Hours

S.N.	Proposed Maintenance	Work Involved	Remarks
1.	Changing of engine oil and filter cartridges.	Refer item no. 1 of first 60 Hours schedule.	
2.	Cleaning of air filter	Refer item no. 2 of first 125 Hours schedule.	
3.	Checking of V-belt, drive and tightness of nuts & bolts.	Refer item no. 3 of first 125 Hours schedule.	
4.	Greasing of generator (auxiliary) (as applicable)	Refer item no. 5 of first 125 Hours schedule.	
5.	Checking of air and water hose piping.	Refer item no. 5 of 250 Hours schedule.	
6.	Checking of zinc protective plugs. (As applicable)	Refer item no. 6 of 250 Hours schedule.	
7.	Checking of coupling disc of fuel pump drive.	Refer item no. 7 of 250 Hours schedule.	
8.	Lubricating of raw water pump.	Fill the grease nipples by means of grease gun.	Multipurpose grease
9.	Checking & resetting of valve clearances.	Check & reset of valve clearances. (Refer item no. 3 of first 30 Hours schedule).	
10.	Checking of speed governor and engine shut down.	Check the function of speed governor and engine shut down by operating manually.	
11.	Checking of battery	Refer item no. 11 of 250 Hours schedule.	
12.	Checking of engine safety devices.	Check proper functioning of engine safety devices.	
13.	Record engine parameters	<ul style="list-style-type: none"> • LOP (Lube oil pressure) • LOT (Lube oil temperature) • WT (Water temperature) • Amps. • Volts • kW 	
14.	Lubrication of starter	Lubricate starter as recommended.	

3.11 1750 घंटे होने पर अनुरक्षण 1750 HOURS MAINTENANCE

Expected date of 1750 hours maintenance:

Actual Date

Actual Hours

S.N.	Proposed Maintenance	Work Involved	Remarks
1.	Changing of engine oil and filter cartridges.	Refer item no. 1 of first 60 Hours schedule.	
2.	Cleaning of air filter	Refer item no. 2 of first 125 Hours schedule.	
3.	Checking of V-belt, drive and tightness of nuts & bolts.	Refer item no. 3 of first 125 Hours schedule.	
4.	Greasing of generator (auxiliary) (as applicable)	Refer item no. 5 of first 125 Hours schedule.	
5.	Checking of air and water hose piping.	Refer item no. 5 of 250 Hours schedule.	
6.	Checking of zinc protective plugs. (As applicable)	Refer item no. 6 of 250 Hours schedule.	
7.	Checking of coupling disc of fuel pump drive.	Refer item no. 7 of 250 Hours schedule.	
8.	Lubricating of raw water pump.	Fill the grease nipples by means of grease gun.	Multipurpose grease
9.	Checking & resetting of valve clearances.	Check & reset of valve clearances. (Refer item no. 3 of first 30 Hours schedule).	
10.	Checking of speed governor and engine shut down.	Check the function of speed governor and engine shut down by operating manually.	
11.	Checking of battery	Refer item no. 11 of 250 Hours schedule.	
12.	Checking of engine safety devices.	Check proper functioning of engine safety devices.	
13.	Record engine parameters	<ul style="list-style-type: none"> • LOP (Lube oil pressure) • LOT (Lube oil temperature) • WT (Water temperature) • Amps. • Volts • kW 	

3.12 2000 घंटे होने पर अनुरक्षण 2000 HOURS MAINTENANCE

Expected date of 2000 hours maintenance:

Actual Date

Actual Hours

S.N.	Proposed Maintenance	Work Involved	Remarks
1.	Changing of engine oil and filter cartridges.	Refer item no. 1 of first 60 Hours schedule.	
2.	Cleaning of air filter	Refer item no. 2 of first 125 Hours schedule.	
3.	Checking of V-belt, drive and tightness of nuts & bolts.	Refer item no. 3 of first 125 Hours schedule.	
4.	Greasing of generator (auxiliary) (as applicable)	Refer item no. 5 of first 125 Hours schedule.	
5.	Checking of air and water hose piping.	Refer item no. 5 of 250 Hours schedule.	
6.	Checking of zinc protective plugs. (As applicable)	Refer item no. 6 of 250 Hours schedule.	
7.	Checking of coupling disc of fuel pump drive.	Refer item no. 7 of 250 Hours schedule.	
8.	Lubricating of raw water pump.	Fill the grease nipples by means of grease gun.	Multipurpose grease
9.	Checking & resetting of valve clearances.	Check & reset of valve clearances. (Refer item no. 3 of first 30 Hours schedule).	
10.	Checking of speed governor and engine shut down.	Check the function of speed governor and engine shut down by operating manually.	
11.	Checking of battery	Refer item no. 11 of 250 Hours schedule.	
12.	Checking of ball bearings and replacement of 'V' belt.	Check ball bearings on cooling water pump, take up pulleys, replace 'V' belt.	
13.	Checking of flexible coupling	Check flexible coupling for its condition and clamps.	
14.	Checking of injectors	Check injectors for proper functioning.	
15.	Replacement of fuel filter elements	<ul style="list-style-type: none"> • Close fuel cock. • Unscrew centre bolt and remove cover. • Renew fuel filter elements. • Clean sealing surface on cover and housing with lint free cloth. • Provide new sealing rings under cover and centre bolt and tighten cover with centre bolt. 	

S.N.	Proposed Maintenance	Work Involved	Remarks
		<ul style="list-style-type: none"> • Open bleed plug and fuel cock. • Operate priming pump until fuel emerges free of bubbles. Then reclose the bleed plug. • Check for filter leakage with engine running. 	
16.	Cleaning of crankcase ventilation.	Clean crankcase ventilation thoroughly.	
#17.	Checking and cleaning of inlet ducts.	Clean inlet ducts properly and check for any obstruction.	
18.	Cleaning of exhaust piping.	<ul style="list-style-type: none"> • Remove all exhaust piping. • Clean exhaust piping thoroughly for removing carbon deposition. • Check their condition and refit with proper clamping. 	
19.	Checking of thermostats.	Check thermostats for proper functioning.	
20.	Cleaning of heat exchanger.	Clean heat exchanger thoroughly for removing dirt and deposits.	
21.	Checking of monitoring functions.	Check all monitoring devices for their proper functions.	
22.	Cleaning of cooling water spaces.	Clean all cooling water spaces.	
23.	Replacement of anti- vibration damper pads.	Replace all anti-vibration damper pads.	
24.	Checking of compressions.	Check compressions.	
25.	Cleaning of inter cooler.	<ul style="list-style-type: none"> • Clean heat exchanger thoroughly for removing dirt and deposits from the cooling tubes walls. • For cleaning recommended detergent solution shall be used. • Then wash the nest of tubes with clean water and put into a neutralizing agent for 10 minutes and then again wash out with water. 	P3T1166 -Henkel P3-croni (Neutra- lization)
26.	Carbon brushes and starter pinion.	<ul style="list-style-type: none"> • Renew carbon brushes. • Check starter pinion and renew if required. 	
27.	Checking of carbon brushes of generator (auxiliary) and lubrication of bearings.	<ul style="list-style-type: none"> • Check carbon brushes for their condition and replace if required. • Lubricate both end bearings. 	
28.	Checking of clearances of bearings of turbo-charger.	Check clearances of bearings of turbo-charger.	

अध्याय 4 CHAPTER 4

किर्लोसकर डीजल इंजनों का अनुरक्षण (एसएल 90 सीरीज) MAINTENANCE OF KIRLOSKAR DIESEL ENGINES (SL 90 SERIES)

4.1 अ-शैड्यूल (दैनिक अनुरक्षण) A-SCHEDULE (DAILY MAINTENANCE)

SN.	Proposed Maintenance	Work Involved	Remarks
1.	Cleaning	Clean engine and premises.	
2.	Checking of engine oil level.	Check engine oil level before starting the engine, top-up if required.	It should be between top and bottom mark of dipstick
3.	Checking of fuel supply.	<ul style="list-style-type: none"> • Drain sediments from fuel tank. Check and ensure sufficient quantity of fuel. • Clean breather hole on fuel tank. • Fill up the fuel tank at the end of each working day. 	Never wait until the tank is empty
4.	Checking of air filter/ system	<ul style="list-style-type: none"> • Remove dust accumulated in the dry type air filter bowl, through vacuator valve. • Check the condition of rubber hoses and clamps. 	
5.	Checking of cooling system	Check coolant level in radiator, top-up if required.	
6.	Checking of battery.	Check battery terminal and connections.	
7.	Checking of engine parameters	Check all meters for normal working in engine running condition.	

4.2 संस्थापन के बाद केवल पहले 50 घंटे होने पर अनुरक्षण ONLY AT FIRST 50 HOURS MAINTENANCE AFTER COMMISSIONING

Date of commissioning.....

Date of first 50 hours maintenance:

SN.	Proposed Maintenance	Work Involved	Remarks
1.	Changing of engine oil	<ul style="list-style-type: none"> • Warm up engine and stop. • Remove drain plug at the bottom of the sump and drain engine oil. • Refit drain plug. • Fill the recommended new engine oil to top mark on dipstick. 	

SN.	Proposed Maintenance	Work Involved	Remarks
2.	Cleaning of centrifugal filter.	<ul style="list-style-type: none"> • Clean centrifugal filter and its surroundings before opening it. • Clean filter rotor cover and inner parts in kerosene/ diesel and dry it with compressed air. • Fit the new paper wrapper in the rotor cover and replace the rubber rings if required. • Fit the rotor and close the cover and provide top nut. • Ensure that the oil inlet pipe is in position. 	
3.	Changing of spin –on type filters	<ul style="list-style-type: none"> • Clean filter and its surroundings before removing it. • Remove the filter from filter bracket. • Replace the rubber ring between filter and header if required. • Assemble both new filters. 	
4.	Checking of lube system	<ul style="list-style-type: none"> • Run the engine for few minutes to check leakages. • Stop the engine, check and top up oil level if required. 	
5.	Checking of fuel supply system.	Check all the fuel pipe joints, banjo boards for tightness and any leakage.	
6.	Checking of air filter/ system	Remove dust accumulated in the dry type air filter bowl, through vacuator valve.	
7.	Checking of cooling system	Check coolant level in radiator, top-up if required.	
8.	Checking of valve tappet clearance.	Check valve tappet clearance in cold engine with a filler gauge .	0.35mm – inlet valve, 0.55mm- exhaust valve
9.	Checking of ‘V’ belts tension.	Check ‘V’ belts tension by pressing with the thumb midway between the pulleys.	Deflection not more than 10 to 15 mm
10.	Checking of battery.	<ul style="list-style-type: none"> • Check electrolyte level and specific gravity of battery. • Add distilled water if required. • Check terminals tightness and clean the battery. 	
11.	Other maintenance	<ul style="list-style-type: none"> • Check all external fasteners, especially those of manifolds, bends, turbocharger, engine mounting and rubber hoses etc. • Check leaks, if any and correct. 	

4.3 ब-शैड्यूल (प्रत्येक 50 घंटे के बाइ अनुरक्षण)

B-SCHEDULE (MAINTENANCE AFTER EVERY 50 HOURS)

SN.	Proposed Maintenance	Work Involved	Remarks
1.	Repeat Maintenance	Repeat A- Schedule	
2.	Checking of air filter/ system	<ul style="list-style-type: none"> In very dusty condition, clean the bowl of dry type air cleaner and if necessary change the element. In normal working condition, this is to be done only when a need for air cleaner service is indicated by the restriction indicator. 	After filter replacement, reset the indicator
3.	Checking of 'V' belts tension	Check 'V' belts tension by pressing with the thumb midway between the pulleys.	Deflection not more than 10 to 15 mm
4.	Checking of battery.	Check electrolyte level, add distilled water if required.	
5.	Other maintenance	Check the cable connections at starter, battery, dynamo/ alternator and control panel.	

4.4 सी-शैड्यूल (प्रत्येक 300 घंटे के बाइ अनुरक्षण)

C- SCHEDULE (MAINTENANCE AFTER EVERY 300 HOURS)

SN.	Proposed Maintenance	Work Involved	Remarks
1.	Repeat Maintenance	Repeat A & B - Schedule	
2.	Changing of engine oil	Refer item no. 1 of first 50 hrs. Maintenance	300 hrs. or 12 months which ever is earlier
3.	Cleaning of centrifugal filter.	Refer item no. 2 of first 50 hrs. Maintenance	
4.	Checking of lube system	Refer item no. 4 of first 50 hrs. Maintenance	
5.	Fuel supply system	<ul style="list-style-type: none"> Drain the fuel filter bowls to remove the accumulated sediments and water. Clean the preliminary filter sieve with clean diesel, fitted on feed pump inlet. 	

4.5 डी-शैड्यूल (प्रत्येक 600 घंटे के बाइ अनुरक्षण)

D- SCHEDULE (MAINTENANCE AFTER EVERY 600 HOURS)

SN.	Proposed Maintenance	Work Involved	Remarks
1.	Repeat Maintenance	Repeat A, B & C - Schedule	
2.	Changing of spin –on type filters	Refer item no. 3 of first 50 hrs. Maintenance	
4.	Fuel supply system	Replace the pre filter insert of fuel filter. (Do not change pre-filter & micro filter insert at the same time, first change the pre filter insert and after about 200 to 250 hours. change micro-filter insert.)	
	Checking of valve tappet clearance.	Refer item no. 8 of first 50 hrs. Maintenance	

4.6 ई-शैड्यूल (प्रत्येक 1200 घंटे के बाइ अनुरक्षण)

E - SCHEDULE (MAINTENANCE AFTER EVERY 1200 HOURS)

SN.	Proposed Maintenance	Work Involved	Remarks
1.	Repeat Maintenance	Repeat A, B, C & D - Schedule	
2.	Checking of fuel injector	Check the nozzle spray on nozzle tester. Replace the nozzle sealing washer and refit the nozzle and connect high pressure pipe.	
3.	Cleaning of fuel tank	Clean the fuel tank thoroughly with diesel. Do not use water for cleaning.	1200 hrs. or every 6 months whichever is earlier
4.	Cleaning of radiator	Clean radiator externally by blowing pressurised air in the reverse direction of the flow of radiator fan.	Do not spill water on radiator fins.
5.	Checking of thermostat element.	Check thermostat element for its safe operation by visual inspection. Its element shall rest in its seat i.e. it should close tightly.	
6.	Other maintenance	Inspect electrical unit i.e. starter, dynamo/ alternator, regulator etc. Replace worn out, defective parts and carbon brushes as required. Lubricate dynamo, starter etc. as required.	

अध्यास 5 CHAPTER 5

क्यूमिन्स के डीजल इंजनों का अनुरक्षण (बी सीरीज) MAINTENANCE OF CUMMINS DIESEL ENGINES (B SERIES)

5.1 ए-चैक (दैनिक अनुरक्षण) A-CHECK (DAILY MAINTENANCE)

SN.	Proposed Maintenance	Work Involved	Remarks
1.	Cleaning	Clean engine and premises.	
2.	Checking of engine oil level.	Check engine oil level before starting the engine, top-up if required.	It should be between H and L mark of dipstick
3.	Checking of coolant system	Check coolant level in radiator, top-up if required with premix coolant. Check belt condition.	Before starting
4.	Checking of fuel system	<ul style="list-style-type: none"> • Check fuel strainer • Clean breather on fuel tank • Drain sediments/water from fuel water separator. • Fill up the fuel tank at the end of each working day. 	Never wait until the tank is empty
4.	Checking of air system	<ul style="list-style-type: none"> • Check vacuum indicator for air restriction (red band). • Check sealing and condition of air filter. 	
5.	Other checks	<ul style="list-style-type: none"> • Check for leaks and rectify if required. • Run engine and record all parameters. 	

5.2 बी-चैक (प्रत्येक 225–250 घन्टे या 6 माह इसमें जो पहले हो) B-CHECK (EVERY 225-250 HRS. OR 6 MONTHS WHICHEVER IS EARLIER)

SN.	Proposed Maintenance	Work Involved	Remarks
1.	Changing of lubrication oil	<ul style="list-style-type: none"> • Warm up the engine and stop. • Remove drain plug and drain engine oil in a pan of 20 ltrs. capacity. • Refit drain plug. • Fill the recommended new engine oil to H mark on dipstick. 	
2.	Changing of lube oil filter	<ul style="list-style-type: none"> • Clean filter head and its surroundings before removing it. • Remove the filter and clean the gasket surface. 	

SN.	Proposed Maintenance	Work Involved	Remarks
		<ul style="list-style-type: none"> Fill the new filter with clean lubricating oil and apply a light film of lube oil to the gasket sealing surface. Fit the filter manually. 	
3.	Checking of cooling system	<ul style="list-style-type: none"> Repeat all A- checks Check fan hub and fan drive arrangement. Check seal of radiator cap. 	
4.	Changing of fuel filter and water separator	<ul style="list-style-type: none"> Repeat all A- checks Remove the two filters from the dual filter adapter. Fill the new filters with clean fuel and apply a light film of lube oil to the seal. Fit the filters manually. Drain sediments from fuel tank. 	
5.	Checking of air filter/ system	<ul style="list-style-type: none"> Repeat all A- checks Clean air filter in reverse direction using dry air with maximum pressure 0.5 kg/sq.cm. 	
6.	Other checks	<ul style="list-style-type: none"> Repeat all A checks. Check electrolyte level and specific gravity of battery. Add distilled water if required. Check terminals tightness and clean the battery. Secure all connectors in engine electrical system. 	

5.3 सी-चैक (प्रत्येक 475–500 घण्टे या 12 माह इसमें जो पहले हो)

C-CHECK (EVERY 475-500 HRS. OR 12 MONTHS WHICHEVER IS EARLIER)

SN.	Proposed Maintenance	Work Involved	Remarks
1.	Checking of lubrication system	<ul style="list-style-type: none"> Repeat all A & B checks. Clean breather. 	
2.	Checking of cooling system	<ul style="list-style-type: none"> Repeat all A & B checks Check coolant condition. Check recovery bottle and seal. Check connections and sealing of radiator. Clean radiator externally by blowing pressurised air in the reverse direction of the flow of radiator fan. 	Do not spill water on radiator fins
3.	Checking of fuel system	<ul style="list-style-type: none"> Repeat all A & B checks Check all joints in fuel lines and tighten. Check feed pump and clean baby filter. 	.

SN.	Proposed Maintenance	Work Involved	Remarks
4.	Checking of air filter/ system	Repeat all A & B checks.	
5.	Other checks	<ul style="list-style-type: none"> Repeat all A & B checks Check AVMs (anti vibration mountings) and replace if required. 	

**5.4 डी-चैक (प्रत्येक 950–1000 घन्टे या 24 माह इसमें जो पहले हो)
D-CHECK (Every 950-1000 hrs. or 24 months whichever is earlier)**

SN.	Proposed Maintenance	Work Involved	Remarks
1.	Checking of lubrication system	<ul style="list-style-type: none"> Repeat all A, B & C checks. Clean breather. Check Blow Bye. 	
2.	Checking of cooling system <ul style="list-style-type: none"> Checking of belt, belt tension, belt tensioner. Replacement of coolant. 	<ul style="list-style-type: none"> Repeat all A, B & C checks. Remove the drive belt and inspect the belt for damage. Check the tensioner bearing by spinning pulley under hand pressure, it should spin freely with no rough spots feelings. Check the fan hub bearing by spinning fan hub under hand pressure, it should spin freely without excessive end play. Install the good/new drive belt. Measure the belt deflection at the longest span of the belt. Replace coolant by premix coolant. Replace radiator cap. 	Max. Deflection 9.5-12.7 mm
3.	Checking of fuel system <ul style="list-style-type: none"> Cleaning of fuel tank Checking of fuel hoses 	<ul style="list-style-type: none"> Repeat all A, B & C checks. Clean the fuel tank thoroughly with diesel. Check fuel hoses condition and replace if required. 	Do not use water for cleaning.
4.	Checking of air filter/ system	<ul style="list-style-type: none"> Repeat all A, B & C checks. Check turbocharger end clearances. 	
5.	Other checks	<ul style="list-style-type: none"> Repeat all A, B & C checks Tighten all clamps. Check valve clearances and adjust if required. 	Intake clearance = 0.254mm Exhaust clearance = 0.508 mm

अध्याय 6 CHAPTER 6

महीन्द्रा डीजल इंजनों का अनुरक्षण (पावर रोल) MAINTENANCE OF MAHINDRA DIESEL ENGINES (POWEROL)

6.1 चालू करने से पूर्व की जाँचें PRE STARTING CHECKS

Before starting the engine, the following checks should be performed:

- Ensure that the panel controller is OFF.
- Check engine oil and coolant level.
- Check the fuel level.
- Check belt tension, tighten if required. (Before belt checking, keep the panel OFF to ensure that the engine doesn't start accidentally.)
- Check all hoses for loose connection. Tighten if necessary.
- Check battery terminals for corrosion. Clean as necessary.
- Check the air filter restriction indicator. Replace the Filter if necessary

6.2 इंजन को चालू करना STARTING THE ENGINE

- Ensure the Emergency Stop push button and any remote stop push button are released.
- Turn the mode selector switch to "KEY". Then turn the key to "II" position to start the engine.
- Release the key to "I" position immediately after the engine fired.
- Now check the control panel for indication of any abnormal operation.
- Switch the alternator output circuit breaker "ON".

6.3 दैनिक जाँच DAILY CHECKS

- Inspect the Coolant level.
- Inspect the driving belt for over or loose tension.
- Check the Lube oil level through the dipstick.
- Check for any leakage of fuel, lube oil or coolant.
- Drain the sediments from the fuel water separator.

6.4 साप्ताहिक जाँच WEEKLY CHECKS

In addition to daily checks, carry out following checks:

- Check for obstruction of coolant fan & any sign of rust.
- Tighten nuts & bolts wherever necessary.
- Check if the radiator needs cleaning (typically if the DG is kept in dusty Environment)

**6.5 प्रत्येक 300 घंटे या 3 माह (इसमें जो पहले हो) में अनुरक्षण
MAINTENANCE EVERY 300 HRS OR 3 MONTHS (WHICHEVER IS EARLIER)**

S.N.	Proposed Maintenance	Work Involved	Remarks
1.	Changing of lube oil	<ul style="list-style-type: none"> • Warm up the engine and stop. • Drain completely the old engine oil by opening the drain plug. • Care should be taken, so that no dust is pigmented in the drain screw. • Fill the recommended lube oil as per the engine oil capacity only. 	Ensure that oil grade is API CH4 / SJ SAE 15W40
2.	Changing of lube oil filter.	<ul style="list-style-type: none"> • Remove the old oil filter • Tighten the new oil filter manually. 	Do not use the same oil filter again.
3.	Checking of air cleaner filter	<ul style="list-style-type: none"> • Open the steel clamps given on the filter body. • Remove the bowl by opening four wire clamp given on its body. • Take out the filter element along with the safety cartridge. • Separate the filter element from the cartridge. • Clean the paper element by compressed air in reverse direction. • Replace the paper element in the cartridge if required. 	Maximum pressure of compressed air 1.4 kg/cm ²
4.	Functioning of engine safety devices.	Check functioning of engine safety devices.	
5.	Checking of Cooling system.	<ul style="list-style-type: none"> • Check the coolant level in the recovery bottle, top up if necessary with premix coolant. • Check & adjust the fan belt tension. 	Do not use muddy water for radiator as it may choke the cooling system.

6.6 प्रत्येक 600 घंटे या 6 माह (इसमें जो पहले हो) में अनुरक्षण MAINTENANCE EVERY 600 HRS OR 6 MONTHS (WHICHEVER IS EARLIER)

In addition to 300 hrs/ 3 months maintenance carry out following works.

Note: The replacement that were done at 300 Hrs will now only be checked / cleaned at 600 Hrs in case there is a need of replacement then only replace.

S.N.	Proposed Maintenance	Work Involved	Remarks
1.	Checking/replacement of centrifugal fuel oil filter.	<ul style="list-style-type: none"> Unscrew top nut and remove cleaner cover. lift rotor and drain oil from it. Unscrew rotor nut by holding rotor assembly in hand. Remove rotor cover and deflector inside. Remove dirt collected in rotor cover with blunt knife, clean all rotor parts thoroughly. Assemble rotor in correct sequence of parts. MATCH ARROW MARKS ON ROTOR AND ROTOR COVER. Tighten rotor cover firmly by hand. Install rotor on shaft and assemble cleaner cover. Replace rotor and cover rubber ring if damaged otherwise replace at every 1200 Hrs. Replace centrifugal oil filter assembly if any damage is observed. 	<p>This is a precession assembly.</p> <p>Change rubber rings if damaged is observed.</p> <p>For centrifugal cover nut tightening use 1.2 kg-m Torque.</p>
2.	Other maintenance	<ul style="list-style-type: none"> Inspect electrical unit i.e. starter, dynamo/ alternator, regulator etc. Replace worn out, defective parts and carbon brushes as required. Lubricate dynamo, starter etc. as required. 	

6.7 प्रत्येक 900 घंटे या 9 माह (इसमें जो पहले हो) में अनुरक्षण MAINTENANCE EVERY 900 HRS OR 9 MONTHS (WHICHEVER IS EARLIER)

Repeat the works mentioned above in MAINTENANCE EVERY 300 HRS OR 3 MONTHS

**6.8 1200 घंटे या 12 माह के बाद (इसमें जो पहले हो) अनुरक्षण
AFTER 1200 HRS OR 12 MONTHS WHICHEVER IS EARLIER**

Repeat the works mentioned above in MAINTENANCE EVERY 600 HRS OR 6 MONTHS

In addition carry out battery maintenance as described below:

- Keep the battery clean & dry .Use damp cloth for cleaning.
- Wash the corroded terminal with emery cloth.
- Wash the battery top with warm water & soda.
- Ensure cleaning solution does not enter the cell.
- After cleaning ensure that all vent holes are open.
- When reconnecting ensure good contact of the terminal , tighten clamping bolts.
- Apply acid proof grease or petroleum jelly on terminals
- The electrolyte level should be 3/8” (0.95cm) above the separator in each of the cell. Add distilled water if required.
- Use syringe to add distilled water to cells to ensure no dirt or corrosive salts enter the cells.

अध्याय 7 CHAPTER 7

क्या करें क्या न करें DO'S & DON'TS

7.1 सामान्य GENERAL

7.1.1 क्या करें Do's

Correct Troubles while they are simple.

- Engine shall only be operated or maintained by trained staff / authorised person.
- Cleaning, maintenance and repair work should only be carried out in engine stopped position and also ensure securing against starting.
- Disconnect the battery -ve terminal before any repair to electrical system to ensure human safety.
- Ensure that the engine is operated only from the control panel.
- Ensure that alternator neutral is earthed properly.
- Ensure all the safety switches/devices/trip connections are healthy.
- Ensure sufficient ventilation around acoustic enclosure.
- Ensure availability of first aid box at proper place and check it regularly.
- Ensure availability of fire extinguishers at easily accessible place.
- Smoking and naked flames are prohibited nearby engine housing.
- Connect the load only when generator voltage regulation is normal.
- Run the engine few minutes (3 to 5 minutes) before routine shut down on no load. It will allow the lubricating oil and coolant to carry heat away from the combustion chamber, bearings, shafts etc.
- Clean the oil, fuel, dust etc. and always keep the engine clean and dry.
- Dispose used filters and oil properly to achieve safe work environment and prevention of pollution.
- Move and dispose the material which has been contaminated by fuel/ lube oil to a safe place to avoid fire cases.

7.1.2 क्या न करें Don'ts

- Don't start the engine without checking of engine fuel and level of lubricating oil.
- Don't hold the ignition key in 'ON' position after engine fires as it will lead to starter motor failure.
- Don't hold the ignition key in 'ON' position more than 10-12 seconds if engine does not fire as it may damage starter motor. Wait for at least 2 minutes for next attempt.

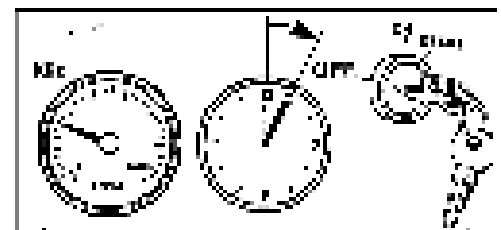

Figure 7.1

- Don't leave the key on dash board after stopping the engine.
- Don't keep inflammable substances in the way of exhaust gases.
- Don't mix different grades of grease.
- Don't remove or open fuel cap of fuel tank while engine is running.
- Don't fill the fuel tank to full capacity.
- Don't mix kerosene or any other fuel to Diesel.
- Do not use cheap/ adulterated fuel which will call expensive repairs of high precision of components such as fuel pump, injection nozzle etc.
- Do not shake diesel drum during filling the fuel in fuel tank. Otherwise the impurities settle at the bottom of the drum will get mixed up with the diesel.
- Don't tight nuts and bolts during engine running, it can cause damage to components.
- Don't touch engine parts just after stopping the engine, they may be hot and may cause serious injuries.
- Don't let oil and other liquids drops into the soil during maintenance.
- Don't wear loose clothing or have long hairs.
- Don't overload the DG beyond its designed rating as it will affect the reliability and life of DG.
- Don't operate the DG with unbalance of load beyond 25% between phases as it may damage to main alternator.
- Don't stop the DG suddenly without off loading the set as it may damage the DG parts.
- Don't allow the engine to run idle for a long period.



Figure 7.2

7.2 हवा प्रणाली AIR SYSTEM

7.2.1 क्या करें Do's

- If air restriction indicator is broken or not functioning, replace the same.
- Clean wet air filters by washing in fuel (Diesel) only.
- Ensure the tightness of clamps and hoses between air cleaner housing and turbocharger.
- Use genuine paper elements/ filters only.
- Remove element from wrapper/packing only at the time of replacement.



Figure 7.3

7.2.2 क्या न करें Don'ts

- Don't operate the engine with choked air cleaner or air cleaner vacuum indicator with red indication as it will lead to black smoke and loss of power etc..
- Don't use water and soap suds for cleaning wet air filters, this will ruin/ damage the filter fabric.
- Don't operate the engine with cracked hoses and loose clamps, as life of engine will be reduced.
- Don't run the engine with the air cleaner or pre-cleaner disconnected.

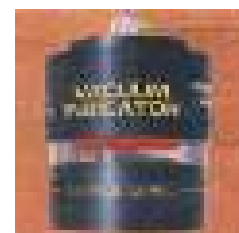

Figure 7.4

7.3 इंधन प्रणाली FUEL SYSTEM

7.3.1 क्या करें Do's

- Fill the diesel tank at the end of the day's work to minimize water drops in fuel tank due to condensation of moisture.
- Before starting the engine, drain water and sediments from water separator as they will re-circulate and fuel filters will get choked early resulting in less efficiency.



Figure 7.5

7.3.2 क्या न करें Don'ts

- Don't operate the DG set with less fuel in fuel tank to avoid air lock and engine starting problem. In case of air lock, operate the hand primer in the feed pump until all air is displaced through the bleeding screw.
- Don't smoke or use any naked flame while refuelling the fuel to avoid any explosion hazard.
- Don't use tools for fitment of fuel filters. Mechanical overtightening may distort the threads or damage the filter element seal.

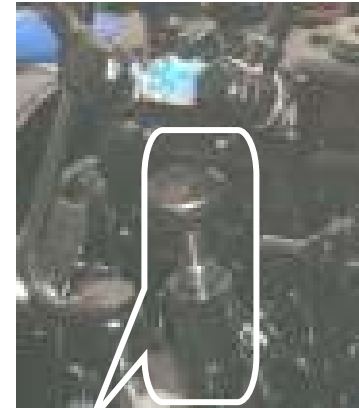

Figure 7.6

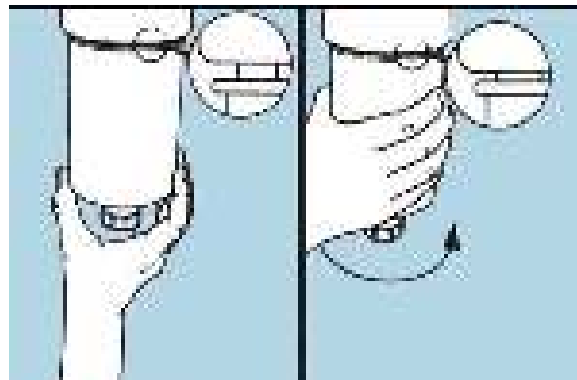

Figure 7.7

7.4 शीतलन प्रणाली COOLING SYSTEM

7.4.1 क्या करें Do's

- Check the coolant level in the recovery bottle before starting the engine and top up, if necessary.
- Use only coolant/pre mix coolant in radiator for recharging as well as for top up.
- Stop the leakage in time if any.
- Clean the radiator fins with compressed air periodically.
- Check the belt tension periodically.
- Replace the belt as soon as the sign of cracks or wear are noticed.

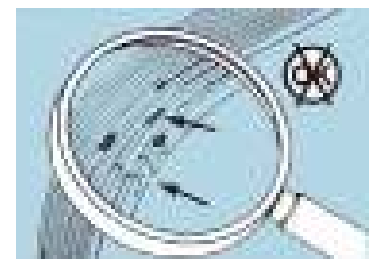

Figure 7.8

7.4.2 क्या न करें Don'ts

- Don't open the radiator cap in radiator with recovery bottle as it will loss air pressure inside radiator which will affect the cooling system.
- Don't change the thermostat setting as it will interfere with proper functioning of cooling system.
- Don't add coolant when engine is hot as it may crack cylinder head.
- Don't operate the engine with mutilated belts or loose belts as it will lead to the problem of overheating.
- Don't tension the belt excessively; this will aggravate wear just as much as slack belts.

7.5 स्नेहन प्रणाली LUBRICATION SYSTEM

7.5.1 क्या करें Do's

- Use correct grade & correct brand of lubricating oil as recommended by OEM.
- Use genuine filters only.
- While topping up the lubricating oil, the funnel and the container must be properly cleaned.

7.5.2 क्या न करें Don'ts

- Don't keep dipstick upwards, otherwise the oil running down would falsify the measuring result.
- Don't add more oil than FULL mark on the dipstick as it will lead to the problem of more oil consumption and higher oil temperature.
- Don't operate the DG set below low level of lube oil on dipstick to avoid oil deterioration and damage to engine parts.
- Don't mix different brands of lubricating oils or mix any other oil to lube oil.
- Don't use tools for fitment of lube filters. Mechanical Over-tightening of the filter may distort the threads or damage the filter element seal.

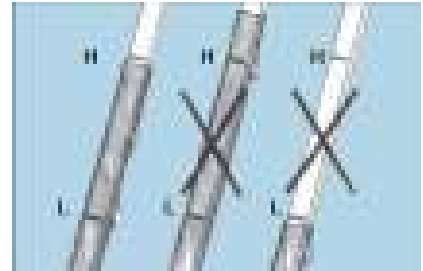

Figure 7.9

अध्याय 8 CHAPTER 8

एफएक्यू (अक्सर पूछे जाने वाले प्रश्न) FAQs (FREQUENTLY ASKED QUESTIONS)

Q.1 Why is maintenance required at different intervals?

Answer: The DG set consists of several mechanical parts, which are subjected to regular wear & tear, as the life of the DG set is governed by many factors, regular maintenance becomes necessary for maintaining this life span & sometimes increasing the life of the DG set.

There are parts in the DG set which have different life span as others, for e.g. the life of the cylinder head is much more than the life of the Piston & Piston rings, in order to maintain the life of the engine, it is necessary that all the parts are serviced periodically according to the manufacturer's recommendation.

However, due to various factors, these service intervals are not adhered to strictly, while doing so there are no immediate effect on the DG set, but on a longer time span the DG set life decreases considerably, which increases the maintenance cost.

Q.2 Why should DG set not be run with low fuel in tank?

Answer: Due to low fuel, the diesel fuel pump will not work properly and there are chances of malfunctioning of fuel injection system.

Q.3 Why should DG set not be run with full fuel in tank?

Answer: High fuel will create improper pressure across the fuel lines and can cause huge amount of Black Smoke.

Q.4 Why is bleeding required?

Answer: The fuel system requires air bleeding under following circumstance:

- If the engine continues to run despite diesel in fuel tank is finished.
- The engine has not been operated for a long time.
- If a fuel element has been replaced.
- Engine is started without opening fuel cock & has run for sometime.
- Feed pump is not working properly.
- If there is some leakage from the Fuel pipes, Benjo & Fuel filter.

Q.5 How to remove AIR LOCK?

Answer: Air lock can be removed by the help of pumping the air primer as procedure given below:

- Loosen the bleeding screw of primary fuel filter. Unscrew priming knob of fuel pump, move it up & down at least 10 to 15 times, till the fuel flows out from air vent screw without air bubbles.
- Tighten the air vent screw after air bleeding. Repeat same steps for secondary fuel filter for air bleeding.
- At last, loosen the air vent screw of fuel injection pump and bleed out air bubbles.

Q.6 What is Thin Film Lubrication?

Answer: Thin Film lubrication is between the Piston rings & the Cylinder Liner, this reduces the metal to Metal contact which reduces friction & wear of metal parts.

Q.7 What is the function of Thermostat?

Answer: The thermostat cuts the engine supply if the temperature of the Engine increases or decreases to a certain level.

Q.8 What is the function of Thermostat valve?

Answer: When coolant is at low temperature, the thermostat valve remains closed and coolant flows through bypass passage to water pump (cooling pump). When coolant temperature is over 90 degree C, thermostat fully opens and bypass closes, coolant passes through the radiator.

Q.9 Why should radiator cap not be opened?

Answer: The radiator cap consists of pressure elements, with the help of the radiator cap the pressure of the cooling system remains in operating condition, loosening the radiator cap will cause changes in the cooling system which will be harmful for the DG set.

Q.10 What is imbalance loading?

Answer: This term is used in three phase system, if there is imbalance among the phases there is a possibility of irregular voltage & shutting down of the system. In order to avoid imbalance the value of load should not be more than or less than 25% among the phases.

Q.11 What is over-speeding?

Answer: There are cases when the speed of the engine increases when load is suddenly taken off from the DG, or there is imbalance of load on the DG. This increases the speed of the Engine which will increase the speed of the alternator beyond a safe limit, which would lead to burning of alternator winding.

Q.12 What is Turbocharger?

Answer: Turbochargers are type of **forced induction systems**. They **compress** the air flowing into the turbine. The advantage of compressing the air is that it lets the engine squeeze more air into a cylinder, and more air means that more fuel can be added. Therefore, we get more power from each power stroke. A turbocharged engine produces more power overall than the same engine without the turbo-charging.

Q.13 Why should engine not be run **Idle** for long period?

Answer: All the components of the Engine are designed to run at a particular speed, in case there is a decrement or Increment of the speed the life of the engine is adversely affected.

Q.14 What should be the colour of exhaust smoke in a healthy engine?

Answer: Healthy Engine emits barely visible smoke if you look at the area surrounding the Exhaust outlet.

Q.15 What is the reason for Black Smoke?

Answer: This indicates improper combustion, which could be due to:

- Choked or wrong air cleaner
- Defective fuel injection system
- Choked exhaust system or wrong exhaust piping
- Engine overload , Load side electrical short circuit

Q.16 What is the reason for Blue Smoke?

Answer: Blue smoke is emitted when oil begins to burn in combustion. This could be due to:

- Excess oil in sump
- Excess lub oil pressure
- Worn piston rings & liners
- Worn valve stem & valve guides
- Excess oil from rocker supply pipe

Q.17 What is the reason for White Smoke?

Answer: White smoke indicates water presence in combustion chamber. This could be due to:

- Cracked Cylinder Head
- Cracked or Damaged Liner
- Water dilution in diesel burnt or damaged cylinder head gasket
- Water presence in combustion chamber which is very dangerous and can lead to a hydraulic lock & extensive damage to engine.

संदर्भ REFERENCE

1. RDSO Specification No. RDSO/ 2009/ EM/ SPEC/ 0002 Rev. 0, July 2010 on Technical specification for supply installation and testing of 5 to 500 kVA Diesel Generating sets.
2. COFMOW specification no. COFMOW/ IR/ DGSET-2008 for Diesle Generating sets 160 kVA to 500 kVA.
3. NF Railway specification No. 04/ spec./ 2006-07 issued by electrical department on Specification for 'Q' kVA DG set for non pumping or mixed loads with minor contribution of pumping load.
4. Operation and Maintenance Manual for G-Drive package B5.9 series 82.5 kVA to 160 kVA DG sets (09-2009) issued by Cummins India Ltd.
5. Users manual, warranty and service log book for D3 series Greaves Diesel Engines issued by Greaves, Diesel Engine Pune.
6. Diesel Genset Owner's Manual, Oct., 2008, Technical Data Handbook March, 09 issued by Mahindra and Mahindra Ltd. for Powerol Gensets.
7. Operation and Maintenance Manual for Kirloskar Diesels SL90 series DG sets issued by Kirloskar oil engines Ltd., Pune.
8. Field study conducted at various Railway installations.
9. Presentations given by M/s Mahindra & Mahindra and Cummins India Ltd. and suggestion given by participants during seminar held at CAMTECH on 06.01.12.
10. Suggestions given by RDSO/ Lucknow.

OUR OBJECTIVE

To upgrade maintenance technologies and methodologies and achieve improvement in productivity, performance of all Railway assets and manpower which inter-alia would cover reliability, availability, utilisation and efficiency.

If you have any suggestions and any specific Comments please write to us.

Contact person : Director (Elect.)

Postal Address : Indian railways
Centre for Advanced
Maintenance technology,
Maharajpur, Gwalior.
Pin code – 474 005

Phone : 0751 – 2470740
0751 – 2470803

E-mail : direlcamtech@gmail.com

Fax : 0751 - 2470841