

Operation and Maintenance Manual

403F-15T, 404F-22 and 404F-22T Industrial Engines

EL (Engine)
EN (Engine)
EP (Engine)

Important Safety Information

Most accidents that involve product operation, maintenance and repair are caused by failure to observe basic safety rules or precautions. An accident can often be avoided by recognizing potentially hazardous situations before an accident occurs. A person must be alert to potential hazards. This person should also have the necessary training, skills and tools to perform these functions correctly.

Incorrect operation, lubrication, maintenance or repair of this product can be dangerous and could result in injury or death.

Do not operate or perform any lubrication, maintenance or repair on this product, until you have read and understood the operation, lubrication, maintenance and repair information.

Safety precautions and warnings are provided in this manual and on the product. If these hazard warnings are not heeded, bodily injury or death could occur to you or to other persons.

The hazards are identified by the "Safety Alert Symbol" and followed by a "Signal Word" such as "DANGER", "WARNING" or "CAUTION". The Safety Alert "WARNING" label is shown below.



The meaning of this safety alert symbol is as follows:

Attention! Become Alert! Your Safety is Involved.

The message that appears under the warning explains the hazard and can be either written or pictorially presented.

Operations that may cause product damage are identified by "NOTICE" labels on the product and in this publication.

Perkins cannot anticipate every possible circumstance that might involve a potential hazard. The warnings in this publication and on the product are, therefore, not all inclusive. You must not use this product in any manner different from that considered by this manual without first satisfying yourself that you have considered all safety rules and precautions applicable to the operation of the product in the location of use, including site-specific rules and precautions applicable to the worksite. If a tool, procedure, work method or operating technique that is not specifically recommended by Perkins is used, you must satisfy yourself that it is safe for you and for others. You should also ensure that you are authorized to perform this work, and that the product will not be damaged or become unsafe by the operation, lubrication, maintenance or repair procedures that you intend to use.

The information, specifications, and illustrations in this publication are on the basis of information that was available at the time that the publication was written. The specifications, torques, pressures, measurements, adjustments, illustrations, and other items can change at any time. These changes can affect the service that is given to the product. Obtain the complete and most current information before you start any job. Perkins dealers or Perkins distributors have the most current information available.



When replacement parts are required for this product Perkins recommends using Perkins replacement parts.

Failure to heed this warning can lead to premature failures, product damage, personal injury or death.

In the United States, the maintenance, replacement, or repair of the emission control devices and systems may be performed by any repair establishment or individual of the owner's choosing.

Table of Contents

Foreword	4	Refill Capacities.....	58
Safety Section		Maintenance Recommendations	71
Safety Messages.....	6	Maintenance Interval Schedule.....	74
General Hazard Information.....	6	Warranty Section	
Burn Prevention.....	9	Warranty Information.....	106
Fire Prevention and Explosion Prevention.....	10	Reference Information Section	
Crushing Prevention and Cutting Prevention..	12	Reference Materials	110
Mounting and Dismounting	12	Index Section	
Before Starting Engine	13	Index.....	111
Engine Starting.....	13		
Engine Stopping	13		
Electrical System.....	14		
Engine Electronics.....	15		
Product Information Section			
General Information	16		
Product Identification Information	27		
Operation Section			
Lifting and Storage	29		
Features and Controls.....	31		
Engine Diagnostics	44		
Engine Starting.....	46		
Engine Operation	49		
Cold Weather Operation	53		
Engine Stopping	57		
Maintenance Section			

Foreword

California Proposition 65 Warning

Diesel engine exhaust and some of its constituents are known to the State of California to cause cancer, birth defects, and other reproductive harm.



WARNING – This product can expose you to chemicals including ethylene glycol, which is known to the State of California to cause birth defects or other reproductive harm. For more information go to:

www.P65Warnings.ca.gov

Do not ingest this chemical. Wash hands after handling to avoid incidental ingestion.



WARNING – This product can expose you to chemicals including lead and lead compounds, which are known to the State of California to cause cancer, birth defects, or other reproductive harm. For more information go to:

www.P65Warnings.ca.gov

Wash hands after handling components that may contain lead.

Literature Information

This manual contains safety, operation instructions, lubrication, and maintenance information. This manual should be stored in or near the engine area in a literature holder or literature storage area. Read, study, and keep the manual with the literature and engine information.

English is the primary language for all Perkins publications. The English used facilitates translation and consistency.

Some photographs or illustrations in this manual show details or attachments that may be different from your engine. Guards and covers may have been removed for illustrative purposes. Continuing improvement and advancement of product design may have caused changes to your engine which are not included in this manual. Whenever a question arises regarding your engine, or this manual, please consult with your Perkins dealer or your Perkins distributor for the latest available information.

Safety

This safety section lists basic safety precautions. In addition, this section identifies hazardous, warning situations. Read and understand the basic precautions listed in the safety section before operating or performing lubrication, maintenance, and repair on this product.

Operation

Operating techniques outlined in this manual are basic. The operating techniques assist with developing the skills and techniques required to operate the engine more efficiently and economically. Skill and techniques develop as the operator gains knowledge of the engine and the capabilities of the engine.

The operation section is a reference for operators. Photographs and illustrations guide the operator through procedures of inspecting, starting, operating, and stopping the engine. This section also includes a discussion of electronic diagnostic information.

Maintenance

The maintenance section is a guide to engine care. The illustrated, step-by-step instructions are grouped by service hours and/or calendar time maintenance intervals. Items in the maintenance schedule are referenced to detailed instructions that follow.

Recommended service should be performed at the appropriate intervals as indicated in the Maintenance Interval Schedule. The actual operating environment of the engine also governs the Maintenance Interval Schedule. Therefore, under severe, dusty, wet, or freezing cold operating conditions, more frequent lubrication, and maintenance than is specified in the Maintenance Interval Schedule may be necessary.

The maintenance schedule items are organized for a preventive maintenance management program. If the preventive maintenance program is followed, a periodic tune-up is not required. The implementation of a preventive maintenance management program should minimize operating costs through cost avoidances resulting from reductions in unscheduled downtime and failures.

Maintenance Intervals

Perform maintenance on items at multiples of the original requirement. Each level and/or individual items in each level should be shifted ahead or back depending upon your specific maintenance practices, operation, and application. Perkins recommends that the maintenance schedules be reproduced and displayed near the engine as a convenient reminder. Perkins also recommends that a maintenance record be maintained as part of the permanent record of the engine.

Your authorized Perkins dealer or your Perkins distributor can assist you in adjusting your maintenance schedule to meet the needs of your operating environment.

Overhaul

Major engine overhaul details are not covered in the Operation and Maintenance Manual except for the interval and the maintenance items in that interval. Major repairs are best left to trained personnel or an authorized Perkins distributor or dealer. Your Perkins dealer or your Perkins distributor offers various options regarding overhaul programs. If you experience a major engine failure, there are also numerous after failure overhaul options available. Consult with your Perkins dealer or your Perkins distributor for information regarding these options.

Safety Section

i05139549

Safety Messages

There may be several specific warning signs on your engine. The exact location and a description of the warning signs are reviewed in this section. Become familiar with all warning signs.

Ensure that all of the warning signs are legible. Clean the warning signs or replace the warning signs if the words cannot be read or if the illustrations are not visible. Use a cloth, water, and soap to clean the warning signs. Do not use solvents, gasoline, or other harsh chemicals. Solvents, gasoline, or harsh chemicals could loosen the adhesive that secures the warning signs. The warning signs that are loosened could drop off the engine.

Replace any warning sign that is damaged or missing. If a warning sign is attached to a part of the engine that is replaced, install a new warning sign on the replacement part. Your Perkins dealer or your distributor can provide new warning signs.

(1) Universal Warning

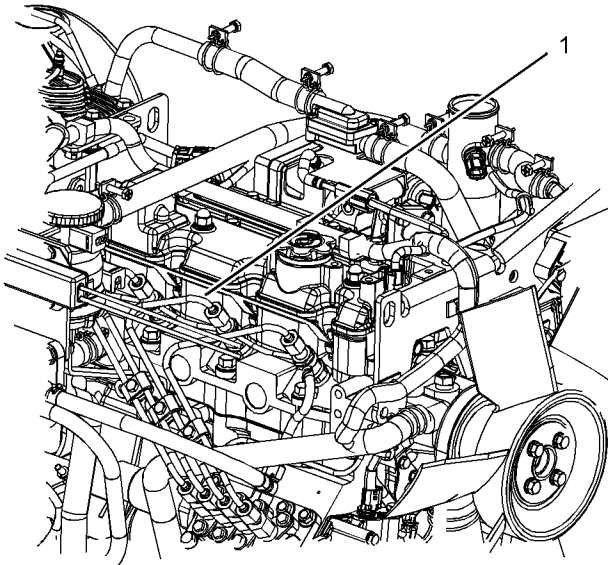

Illustration 1

g03256898

(1) Universal Warning

WARNING

Do not operate or work on this equipment unless you have read and understand the instructions and warnings in the Operation and Maintenance Manuals. Failure to follow the instructions or heed the warnings could result in serious injury or death.

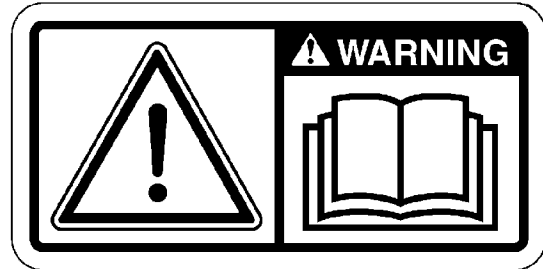

Illustration 2

g01154807

Typical example

The location of the universal warning label is located on the right side of the valve mechanism cover.

i08323375

General Hazard Information

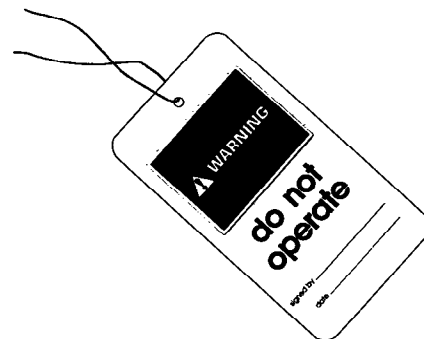

Illustration 3

g00104545

Attach a "Do Not Operate" warning tag or a similar warning tag to the start switch or to the controls before you service the equipment or before you repair the equipment.

- Tampering with the engine installation or tampering with the OEM supplied wiring can be dangerous. Personal injury, death and/or engine damage could result.

- Vent the engine exhaust to the outside when the engine is operated in an enclosed area.
- If the engine is not running, do not release the secondary brake or the parking brake systems unless the vehicle is blocked or unless the vehicle is restrained.
- Wear a hard hat, protective glasses, and other protective equipment, as required.
- When work is performed around an engine that is operating, wear protective devices for ears to help prevent damage to hearing.
- Do not wear loose clothing or jewelry that can snag on controls or on other parts of the engine.
- Ensure that all protective guards and all covers are secured in place on the engine.
- Never put maintenance fluids into glass containers. Glass containers can break.
- Use all cleaning solutions with care.
- Report all necessary repairs.

Unless other instructions are provided, perform the maintenance under the following conditions:

- The engine is stopped. Ensure that the engine cannot be started.
- The protective locks or the controls are in the applied position.
- Engage the secondary brakes or parking brakes.
- Block the vehicle or restrain the vehicle before maintenance or repairs are performed.
- Disconnect the batteries when maintenance is performed or when the electrical system is serviced. Disconnect the battery ground leads. Tape the leads to help prevent sparks.
- Do not attempt any repairs or any adjustments to the engine while the engine is operating.
- Do not attempt any repairs that are not understood. Use the proper tools. Replace any equipment that is damaged or repair the equipment.
- For initial start-up of a new engine or for starting an engine that has been serviced, make provisions to stop the engine if an overspeed occurs. The stopping of the engine may be accomplished by shutting off the fuel supply and/or the air supply to the engine. Ensure that only the fuel supply line is shut off. Ensure that the fuel return line is open.

- Start the engine from the operators station (cab). Never short across the starting motor terminals or the batteries. This action could bypass the engine neutral start system and/or the electrical system could be damaged.

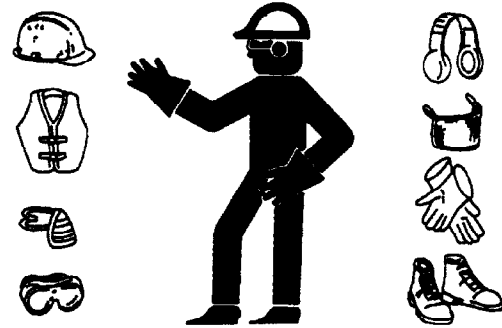

Illustration 4

g00702020

Wear a hard hat, protective glasses, and other protective equipment, as required.

Do not wear loose clothing or jewelry that can snag on controls or on other parts of the engine.

Make sure that all protective guards and all covers are secured in place on the engine.

Keep the engine free from foreign material. Remove debris, oil, tools, and other items from the deck, from walkways, and from steps.

Never put maintenance fluids into glass containers. Drain all liquids into a suitable container.

Obey all local regulations for the disposal of liquids.

Use all cleaning solutions with care.

Report all necessary repairs.

Do not allow unauthorized personnel on the equipment.

Ensure that the power supply is disconnected before you work on the bus bar or the glow plugs.

Perform maintenance on the engine with the equipment in the servicing position. Refer to the OEM information for the procedure for placing the equipment in the servicing position.

Pressure Air and Water

Pressurized air and/or water can cause debris and/or hot water to be blown out. This could result in personal injury.

The direct application of pressurized air or pressurized water to the body could result in personal injury.

Safety Section
General Hazard Information

When pressurized air and/or water is used for cleaning, wear protective clothing, protective shoes, and eye protection. Eye protection includes goggles or a protective face shield.

The maximum air pressure for cleaning purposes must be below 205 kPa (30 psi). The maximum water pressure for cleaning purposes must be below 275 kPa (40 psi).

Fluid Penetration

Pressure can be trapped in the hydraulic circuit long after the engine has been stopped. The pressure can cause hydraulic fluid or items such as pipe plugs to escape rapidly if the pressure is not relieved correctly.

Do not remove any hydraulic components or parts until pressure has been relieved or personal injury may occur. Do not disassemble any hydraulic components or parts until pressure has been relieved or personal injury may occur. Refer to the OEM information for any procedures that are required to relieve the hydraulic pressure.

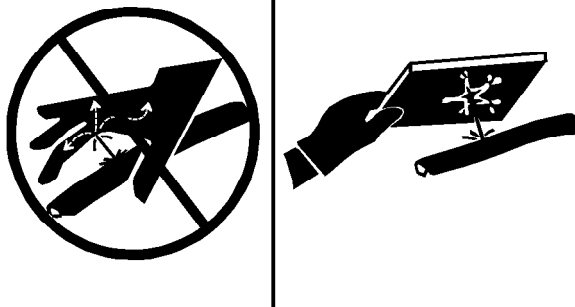

Illustration 5

g00687600

Always use a board or cardboard when you check for a leak. Leaking fluid that is under pressure can penetrate body tissue. Fluid penetration can cause serious injury and possible death. A pin hole leak can cause severe injury. If fluid is injected into your skin, you must get treatment immediately. Seek treatment from a doctor that is familiar with this type of injury.

Containing Fluid Spillage

Care must be taken to ensure that fluids are contained during performance of inspection, maintenance, testing, adjusting, and repair of the engine. Make provision to collect the fluid with a suitable container before any compartment is opened or before any component is disassembled.

- Only use the tools that are suitable for collecting fluids and equipment that is suitable for collecting fluids.

- Only use the tools that are suitable for containing fluids and equipment that is suitable for containing fluids.

Obey all local regulations for the disposal of liquids.

Inhalation

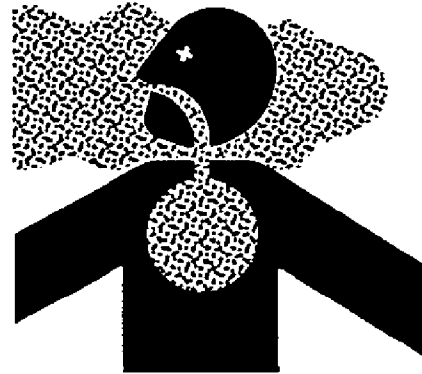

Illustration 6

g00702022

Exhaust

Use caution. Exhaust fumes can be hazardous to health. If you operate the equipment in an enclosed area, adequate ventilation is necessary.

Hexavalent Chromium

Perkins equipment and replacement parts comply with applicable regulations and requirements where originally sold. Perkins recommends the use of only genuine Perkins replacement parts.

Hexavalent chromium has occasionally been detected on exhaust and heat shield systems on Perkins engines. Although laboratory testing is the only accurate way to know if hexavalent chromium is, in fact, present, the presence of a yellow deposit in areas of high heat (for example, exhaust system components or exhaust insulation) may be an indication of the presence of hexavalent chromium.

Use caution if you suspect the presence of hexavalent chromium. Avoid skin contact when handling items that you suspect may contain hexavalent chromium, and avoid inhalation of any dust in the suspect area. Inhalation of, or skin contact with, hexavalent chromium dust may be hazardous to your health.

If such yellow deposits are found on the engine, engine component parts, or associated equipment or packages, Perkins recommends following local health and safety regulations and guidelines, utilizing good hygiene, and adhering to safe work practices when handling the equipment or parts. Perkins also recommends the following:

- Wear appropriate Personal Protective Equipment (PPE)
- Wash your hands and face with soap and water prior to eating, drinking, or smoking, and also during rest room breaks, to prevent ingestion of any yellow powder
- Never use compressed air for cleaning areas suspected of containing hexavalent chromium
- Avoid brushing, grinding, or cutting materials suspected of containing hexavalent chromium
- Obey environmental regulations for the disposal of all materials that may contain or have come into contact with hexavalent chromium
- Stay away from areas that might have hexavalent chromium particles in the air.

Asbestos Information

Perkins equipment and replacement parts that are shipped from Perkins are asbestos free. Perkins recommends the use of only genuine Perkins replacement parts. Use the following guidelines when you handle any replacement parts that contain asbestos or when you handle asbestos debris.

Use caution. Avoid inhaling dust that might be generated when you handle components that contain asbestos fibers. Inhaling this dust can be hazardous to your health. The components that may contain asbestos fibers are brake pads, brake bands, lining material, clutch plates, and some gaskets. The asbestos that is used in these components is usually bound in a resin or sealed in some way. Normal handling is not hazardous unless airborne dust that contains asbestos is generated.

If dust that may contain asbestos is present, there are several guidelines that should be followed:

- Never use compressed air for cleaning.
- Avoid brushing materials that contain asbestos.
- Avoid grinding materials that contain asbestos.
- Use a wet method to clean up asbestos materials.
- A vacuum cleaner that is equipped with a high efficiency particulate air filter (HEPA) can also be used.
- Use exhaust ventilation on permanent machining jobs.
- Wear an approved respirator if there is no other way to control the dust.

- Comply with applicable rules and regulations for the work place. In the United States, use Occupational Safety and Health Administration (OSHA) requirements. These OSHA requirements can be found in "29 CFR 1910.1001".
- Obey environmental regulations for the disposal of asbestos.
- Stay away from areas that might have asbestos particles in the air.

Dispose of Waste Properly

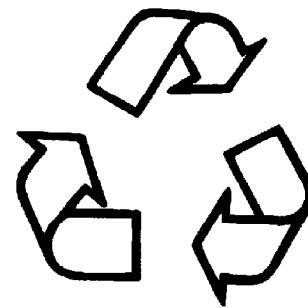

Illustration 7

g00706404

Improperly disposing of waste can threaten the environment. Potentially harmful fluids should be disposed of according to local regulations.

Always use leakproof containers when you drain fluids. Do not pour waste onto the ground, down a drain, or into any source of water.

i05200861

Burn Prevention

Do not touch any part of an operating engine system. The engine, the exhaust, and the engine aftertreatment system can reach temperatures as high as 650 °C (1202 °F) under normal operating conditions.

At idle engine speed and/or zero vehicle speed, an operator can request a manual regeneration. Under this condition, the exhaust gas temperature can reach 650 °C (1202 °F). Otherwise automatic regeneration can produce exhaust gas temperatures as high as 650 °C (1202 °F).

Allow the engine system to cool before any maintenance is performed. Relieve all pressure in the following systems, hydraulic system, lubrication system, fuel system, and the cooling system before related items are disconnected.

WARNING

Contact with high pressure fuel may cause fluid penetration and burn hazards. High pressure fuel spray may cause a fire hazard. Failure to follow these inspection, maintenance and service instructions may cause personal injury or death.

After the engine has stopped, allow if active the regeneration active lamp to be extinguished before any service or repair is performed.

Induction System

WARNING

Sulfuric Acid Burn Hazard may cause serious personal injury or death.

The exhaust gas cooler may contain a small amount of sulfuric acid. The use of fuel with sulfur levels greater than 15 ppm may increase the amount of sulfuric acid formed. The sulfuric acid may spill from the cooler during service of the engine. The sulfuric acid will burn the eyes, skin and clothing on contact. Always wear the appropriate personal protective equipment (PPE) that is noted on a material safety data sheet (MSDS) for sulfuric acid. Always follow the directions for first aid that are noted on a material safety data sheet (MSDS) for sulfuric acid.

Coolant

When the engine is at operating temperature, the engine coolant is hot. The coolant is also under pressure. The radiator and all lines to the heaters or to the engine contain hot coolant.

Any contact with hot coolant or with steam can cause severe burns. Allow cooling system components to cool before the cooling system is drained.

Check that the coolant level after the engine has stopped and the engine has been allowed to cool.

Ensure that the filler cap is cool before removing the filler cap. The filler cap must be cool enough to touch with a bare hand. Remove the filler cap slowly in order to relieve pressure.

Cooling system conditioner contains alkali. Alkali can cause personal injury. Do not allow alkali to contact the skin, the eyes, or the mouth.

Oils

Hot oil and hot lubricating components can cause personal injury. Do not allow hot oil to contact the skin. Also, do not allow hot components to contact the skin.

Batteries

Electrolyte is an acid. Electrolyte can cause personal injury. Do not allow electrolyte to contact the skin or the eyes. Always wear protective glasses for servicing batteries. Wash hands after touching the batteries and connectors. Use of gloves is recommended.

i04047444

Fire Prevention and Explosion Prevention



Illustration 8

g00704000

All fuels, most lubricants, and some coolant mixtures are flammable.

Flammable fluids that are leaking or spilled onto hot surfaces or onto electrical components can cause a fire. Fire may cause personal injury and property damage.

After the emergency stop button has been operated, ensure that you allow 15 minutes, before the engine covers are removed.

Determine whether the engine will be operated in an environment that allows combustible gases to be drawn into the air inlet system. These gases could cause the engine to overspeed. Personal injury, property damage, or engine damage could result.

If the application involves the presence of combustible gases, consult your Perkins dealer and/or your Perkins distributor for additional information about suitable protection devices.

Remove all flammable combustible materials or conductive materials such as fuel, oil, and debris from the engine. Do not allow any flammable combustible materials or conductive materials to accumulate on the engine.

Store fuels and lubricants in correctly marked containers away from unauthorized persons. Store oily rags and any flammable materials in protective containers. Do not smoke in areas that are used for storing flammable materials.

Do not expose the engine to any flame.

Exhaust shields (if equipped) protect hot exhaust components from oil or fuel spray in case of a line, a tube, or a seal failure. Exhaust shields must be installed correctly.

Do not weld on lines or tanks that contain flammable fluids. Do not flame cut lines or tanks that contain flammable fluid. Clean any such lines or tanks thoroughly with a nonflammable solvent prior to welding or flame cutting.

Wiring must be kept in good condition. Ensure that all electrical wires are correctly routed and securely attached. Check all electrical wires daily. Repair any wires that are loose or frayed before you operate the engine. Clean all electrical connections and tighten all electrical connections.

Eliminate all wiring that is unattached or unnecessary. Do not use any wires or cables that are smaller than the recommended gauge. Do not bypass any fuses and/or circuit breakers.

Arcing or sparking could cause a fire. Secure connections, recommended wiring, and correctly maintained battery cables will help to prevent arcing or sparking.

Ensure that the engine is stopped. Inspect all lines and hoses for wear or for deterioration. The hoses must be correctly routed. The lines and hoses must have adequate support and secure clamps.

Oil filters and fuel filters must be correctly installed. The filter housings must be tightened to the correct torque. Refer to the Disassembly and Assembly manual for more information.



Illustration 9

g00704059

Use caution when you are refueling an engine. Do not smoke while you are refueling an engine. Do not refuel an engine near open flames or sparks. Always stop the engine before refueling.



Illustration 10

g00704135

Gases from a battery can explode. Keep any open flames or sparks away from the top of a battery. Do not smoke in battery charging areas.

Never check the battery charge by placing a metal object across the terminal posts. Use a voltmeter or a hydrometer.

Incorrect jumper cable connections can cause an explosion that can result in injury. Refer to the Operation Section of this manual for specific instructions.

Do not charge a frozen battery. Charge a frozen battery may cause an explosion.

The batteries must be kept clean. The covers (if equipped) must be kept on the cells. Use the recommended cables, connections, and battery box covers when the engine is operated.

Fire Extinguisher

Make sure that a fire extinguisher is available. Be familiar with the operation of the fire extinguisher. Inspect the fire extinguisher and service the fire extinguisher regularly. Obey the recommendations on the instruction plate.

Lines, Tubes, and Hoses

Do not bend high-pressure lines. Do not strike high-pressure lines. Do not install any lines that are damaged.

Leaks can cause fires. Consult your Perkins dealer or your Perkins distributor for replacement parts.

Replace the parts if any of the following conditions are present:

- High-pressure fuel line or lines are removed.
- End fittings are damaged or leaking.
- Outer coverings are chafed or cut.
- Wires are exposed.
- Outer coverings are ballooning.
- Flexible parts of the hoses are kinked.
- Outer covers have embedded armoring.
- End fittings are displaced.

Make sure that all clamps, guards, and heat shields are installed correctly. During engine operation, correct installation will help to prevent vibration, rubbing against other parts, and excessive heat.

Regeneration

The exhaust gas temperature during regeneration will be elevated. Follow proper fire prevention instructions and use the disable switch function when appropriate.

i02143194

Crushing Prevention and Cutting Prevention

Support the component correctly when work beneath the component is performed.

Unless other maintenance instructions are provided, never attempt adjustments while the engine is running.

Stay clear of all rotating parts and of all moving parts. Leave the guards in place until maintenance is performed. After the maintenance is performed, reinstall the guards.

Keep objects away from moving fan blades. The fan blades will throw objects or cut objects.

When objects are struck, wear protective glasses in order to avoid injury to the eyes.

Chips or other debris may fly off objects when objects are struck. Before objects are struck, ensure that no one will be injured by flying debris.

i05768982

Mounting and Dismounting

Do not climb on the engine or the engine aftertreatment system. The engine and aftertreatment system have not been designed with mounting or dismounting locations.

Refer to the OEM for the location of foot and hand holds for your specific application.

i05874054

Before Starting Engine

NOTICE

For initial start-up of a new or rebuilt engine, and for start-up of an engine that has been serviced, make provision to shut the engine off should an overspeed occur. This may be accomplished by shutting off the air and/or fuel supply to the engine.

WARNING

Engine exhaust contains products of combustion which may be harmful to your health. Always start and operate the engine in a well ventilated area and, if in an enclosed area, vent the exhaust to the outside.

Inspect the engine for potential hazards.

Do not start the engine or move any of the controls if there is a "DO NOT OPERATE" warning tag or similar warning tag attached to the start switch or to the controls.

Before starting the engine, ensure that no one is on, underneath, or close to the engine. Ensure that the area is free of personnel.

If equipped, ensure that the lighting system for the engine is suitable for the conditions. Ensure that all lights work properly, if equipped.

All protective guards and all protective covers must be installed if the engine must be started in order to perform service procedures. To help prevent an accident that is caused by parts in rotation, work around the parts carefully.

Do not bypass the automatic shutoff circuits. Do not disable the automatic shutoff circuits. The circuits are provided in order to help prevent personal injury. The circuits are also provided in order to help prevent engine damage.

See the Service Manual for repairs and for adjustments.

i02157354

Engine Starting

WARNING

Do not use aerosol types of starting aids such as ether. Such use could result in an explosion and personal injury.

If a warning tag is attached to the engine start switch or to the controls, DO NOT start the engine or move the controls. Consult with the person that attached the warning tag before the engine is started.

All protective guards and all protective covers must be installed if the engine must be started in order to perform service procedures. To help prevent an accident that is caused by parts in rotation, work around the parts carefully.

Start the engine from the operator's compartment or from the engine start switch.

Always start the engine according to the procedure that is described in the Operation and Maintenance Manual, "Engine Starting" topic in the Operation Section. Knowing the correct procedure will help to prevent major damage to the engine components. Knowing the procedure will also help to prevent personal injury.

To ensure that the jacket water heater (if equipped) and/or the lube oil heater (if equipped) is working correctly, check the water temperature gauge and the oil temperature gauge during the heater operation.

Engine exhaust contains products of combustion which can be harmful to your health. Always start the engine and operate the engine in a well ventilated area. If the engine is started in an enclosed area, vent the engine exhaust to the outside.

Note: The engine is equipped with an automatic device for cold starting for normal conditions of operation. If the engine will be operated in very cold conditions, then an extra cold starting aid may be required. Normally, the engine will be equipped with the correct type of starting aid for your region of operation.

The 400 Series engines are equipped with a glow plug starting aid in each individual cylinder that heats the intake air in order to improve starting.

i02234873

Engine Stopping

Stop the engine according to the procedure in the Operation and Maintenance Manual, "Engine Stopping (Operation Section)" in order to avoid overheating of the engine and accelerated wear of the engine components.

Use the Emergency Stop Button (if equipped) ONLY in an emergency situation. Do not use the Emergency Stop Button for normal engine stopping. After an emergency stop, DO NOT start the engine until the problem that caused the emergency stop has been corrected.

Stop the engine if an overspeed condition occurs during the initial start-up of a new engine or an engine that has been overhauled.

To stop an electronically controlled engine, cut the power to the engine and/or shutting off the air supply to the engine.

i04047709

Electrical System

Never disconnect any charging unit circuit or battery circuit cable from the battery when the charging unit is operating. A spark can cause the combustible gases that are produced by some batteries to ignite.

To help prevent sparks from igniting combustible gases that are produced by some batteries, the negative “-” cable should be connected last from the external power source to the primary position for grounding.

Check the electrical wires daily for wires that are loose or frayed. Tighten all loose electrical connections before the engine is started. Repair all frayed electrical wires before the engine is started. See the Operation and Maintenance Manual for specific starting instructions.

Grounding Practices

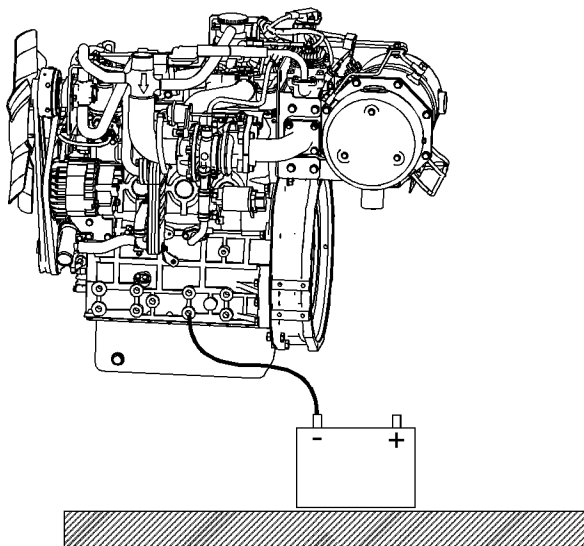

Illustration 11

g02324975

Typical example
Ground to battery

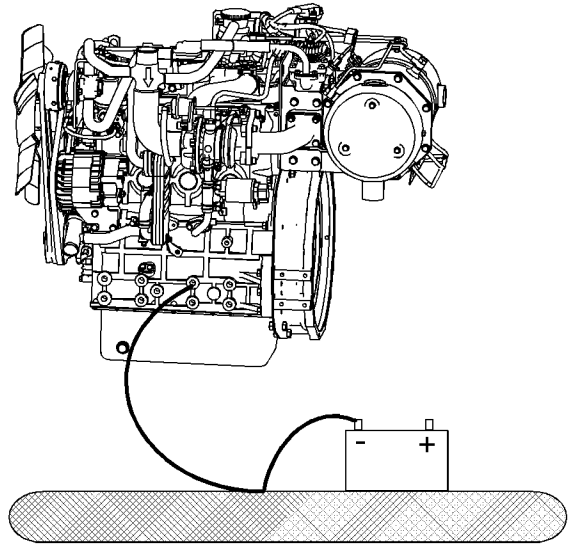

Illustration 12

g02324976

Typical example
Alternate ground to battery

Correct grounding for the engine electrical system is necessary for optimum engine performance and reliability. Incorrect grounding will result in uncontrolled electrical circuit paths and in unreliable electrical circuit paths.

Uncontrolled electrical circuit paths can result in damage to the crankshaft bearing journal surfaces and to aluminum components.

Engines that are installed without engine-to-frame ground straps can be damaged by electrical discharge.

To ensure that the engine and the engine electrical systems function correctly, an engine-to-frame ground strap with a direct path to the battery must be used. This path may be provided by way of a direct engine ground to the frame.

The connections for the grounds should be tight and free of corrosion. The engine alternator must be grounded to the negative “-” battery terminal with a wire that is adequate to handle the full charging current of the alternator.

The power supply connections and the ground connections for the engine electronics should always be from the isolator to the battery.

i05181812

Engine Electronics

WARNING

Tampering with the electronic system installation or the OEM wiring installation can be dangerous and could result in personal injury or death and/or engine damage.

This engine has a comprehensive, programmable Engine Monitoring System. The Electronic Control Module (ECM) has the ability to monitor the engine operating conditions. If any of the engine parameters extend outside an allowable range, the ECM will initiate an immediate action.

The following actions are available for engine monitoring control:

- Warning
- Derate
- Shutdown

The following monitored engine operating conditions and components have the ability to limit engine speed and/or the engine power:

- Oil Pressure Switch
- Coolant Temperature Sensor
- Engine Aftertreatment System

The Engine Monitoring package can vary for different engine models and different engine applications. However, the monitoring system and the engine monitoring control will be similar for all engines.

Note: Many of the engine control systems and display modules that are available for Perkins Engines will work in unison with the Engine Monitoring System. Together, the two controls will provide the engine monitoring function for the specific engine application. Refer to the Troubleshooting for more information on the Engine Monitoring System.

Product Information Section

General Information

i05139695

Model View Illustrations (Engines and Aftertreatment)

The following model views show typical features of the engine. Due to individual applications, your engine may appear different from the illustrations.

403F-15T

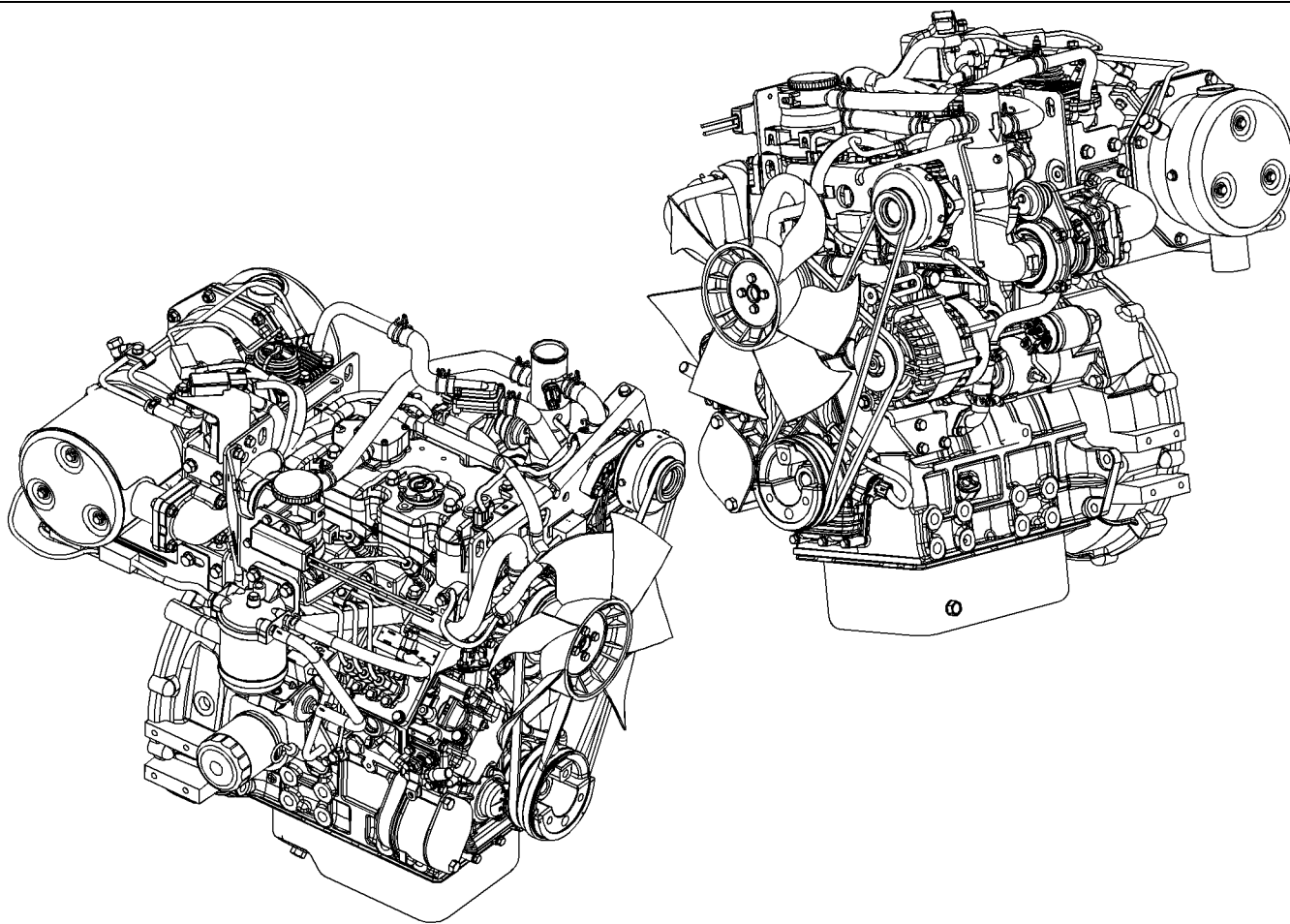

Illustration 13
Typical example

g03246538

404F-22

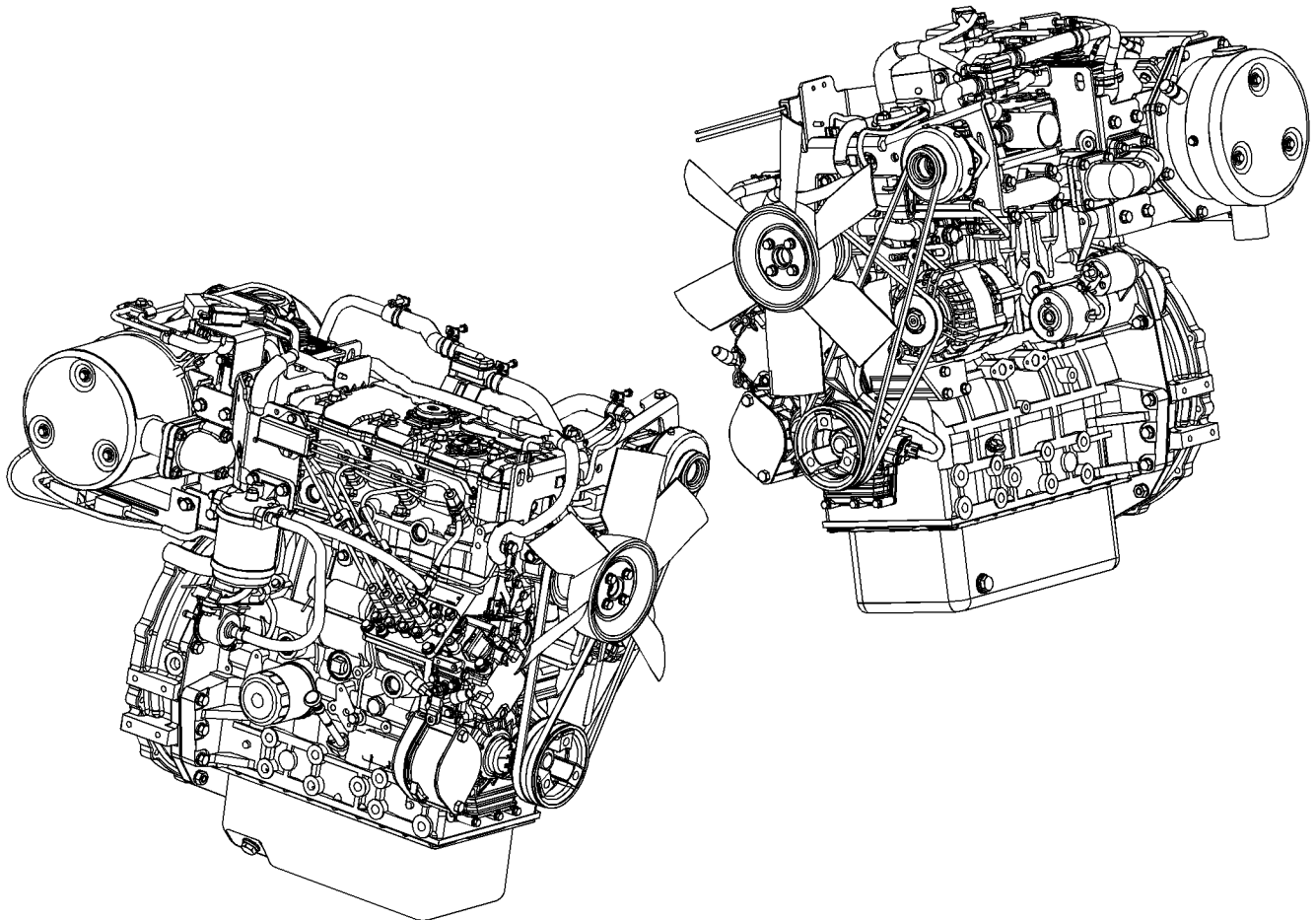

Illustration 14
Typical example

404F-22T

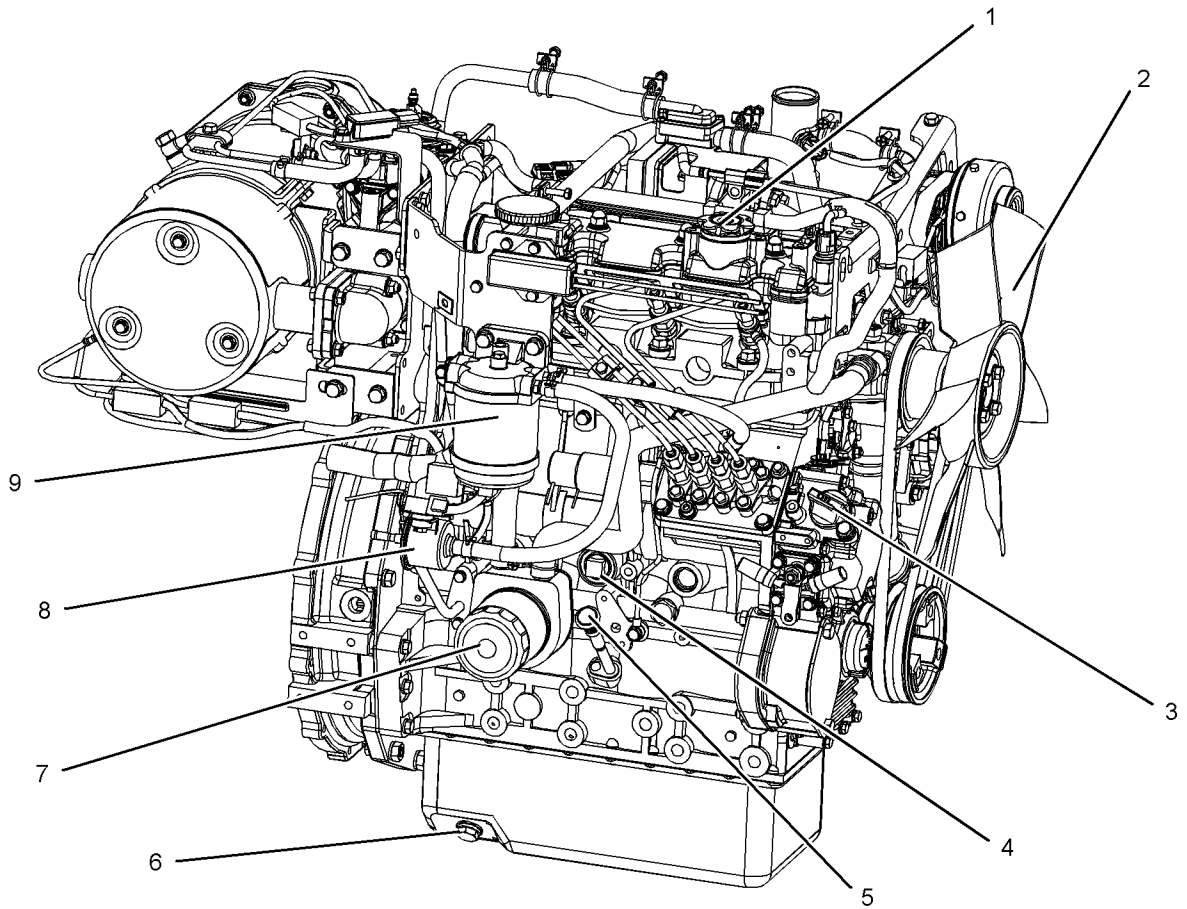

Illustration 15

g03246676

(1) Top oil filler
(2) Fan
(3) Side oil filler

(4) Cylinder block drain plug
(5) Oil gauge (Dipstick)
(6) Rear oil drain plug

(7) Oil filter
(8) Electric fuel pump
(9) Secondary fuel filter

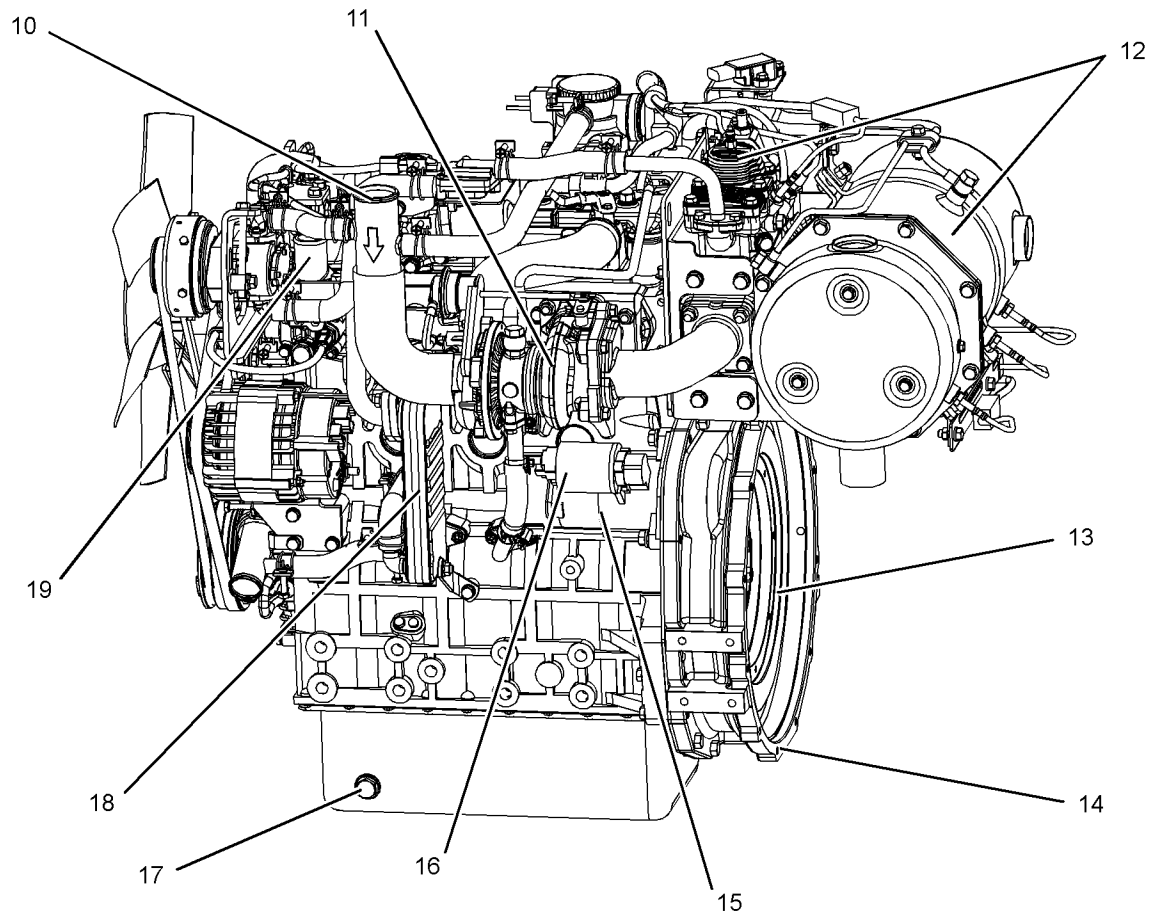

Illustration 16

g03246563

(10) Air intake
 (11) Turbocharger
 (12) Aftertreatment system
 (13) Flywheel

(14) Flywheel housing
 (15) Starting motor
 (16) Solenoid for starting motor
 (17) Front oil drain plug

(18) NOx reduction system cooler
 (19) Coolant outlet

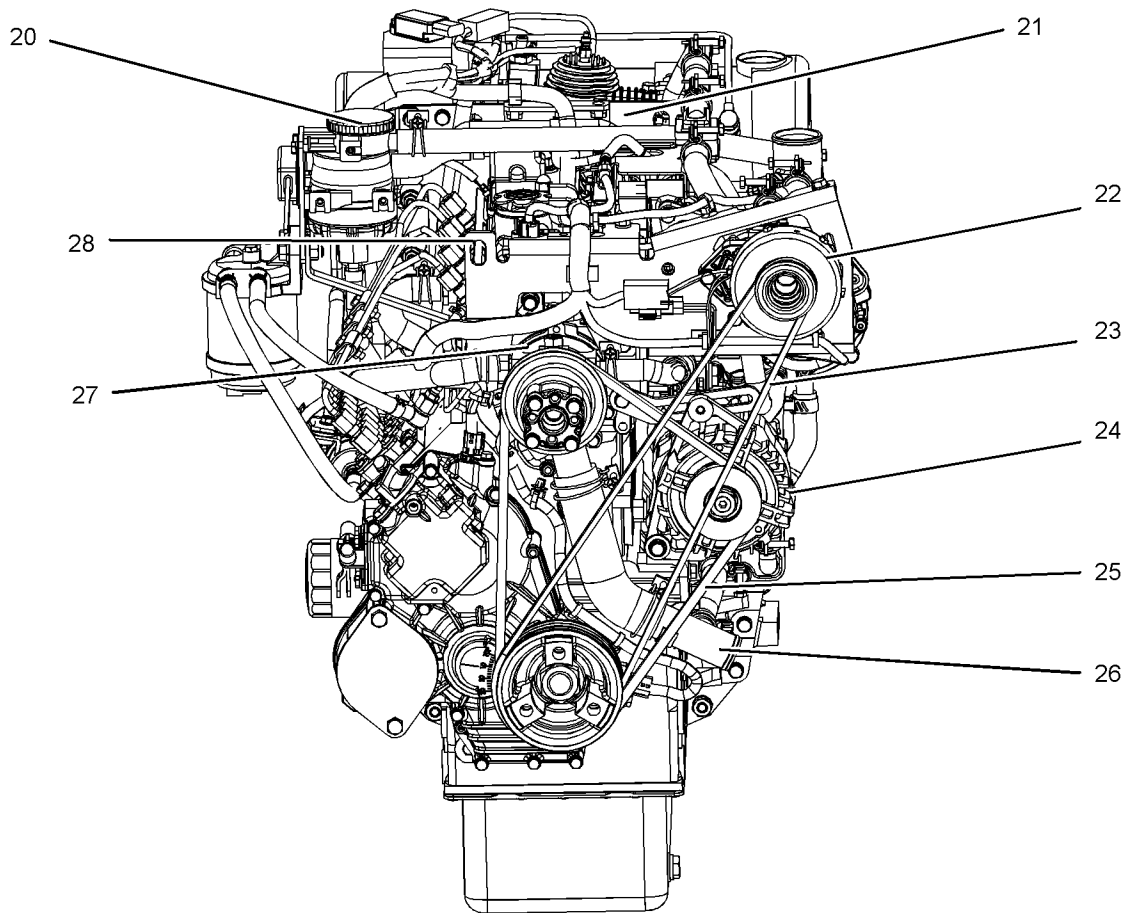

Illustration 17

g03249056

(20) Engine crankcase breather
(21) Rear lifting eye bracket
(22) Air pump

(23) Air pump drive belt
(24) Alternator
(25) Fan and alternator drive belt

(26) Coolant intake
(27) Water pump
(28) Front lifting eye

Aftertreatment System

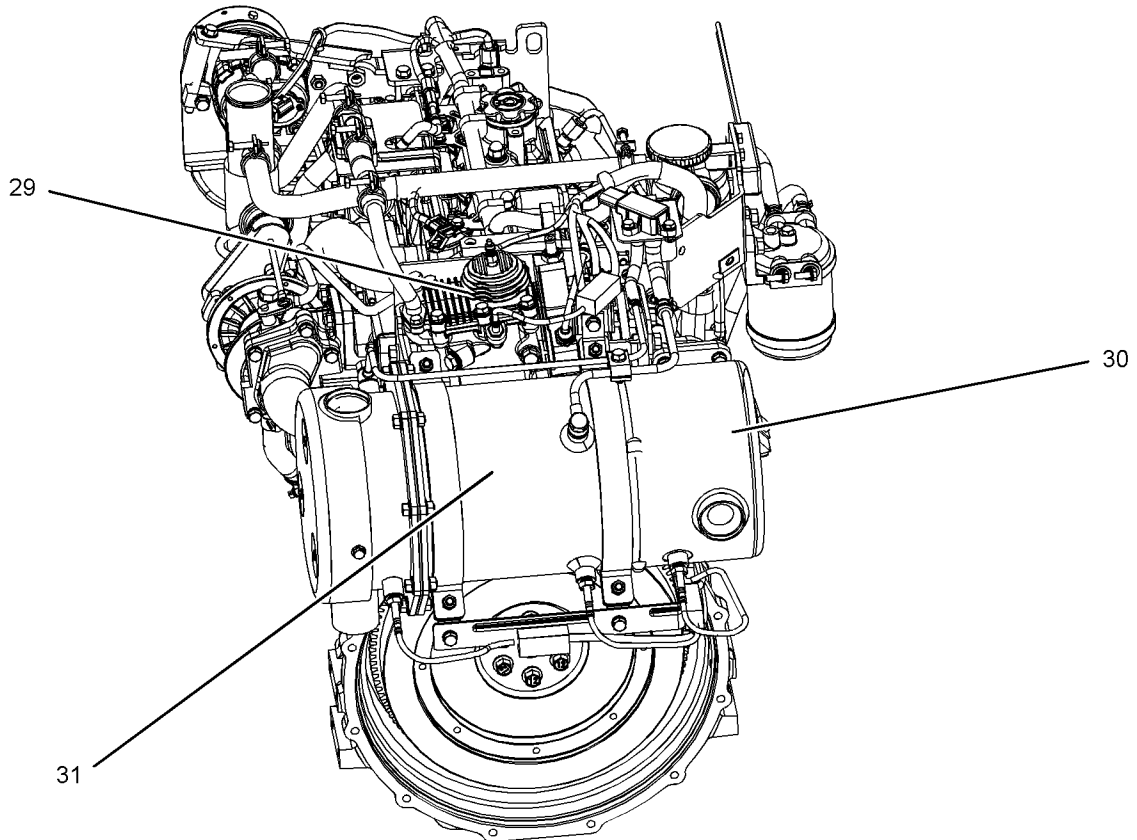

Illustration 18

g03249241

(29) Aftertreatment Regeneration Device
(ARD), also known as the (Burner)

(30) Diesel Oxidation Catalyst (DOC)
(31) Diesel Particulate Filter (DPF)

Off Engine Parts

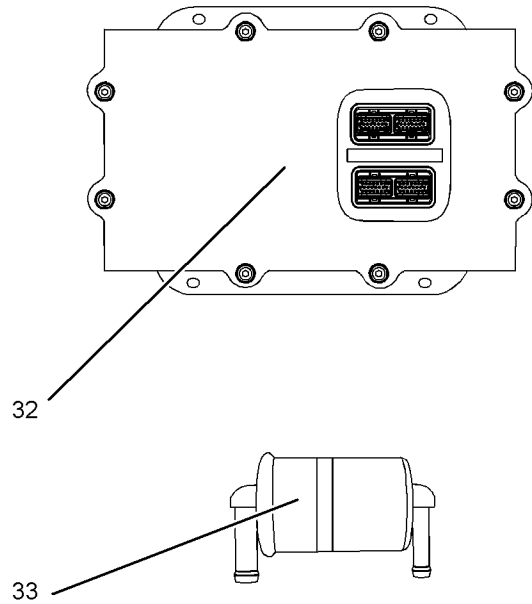

Illustration 19

g03271819

(32) Electronic Control Unit (ECM)
(33) In line fuel filter

Engine with Low Mounted Air Pump

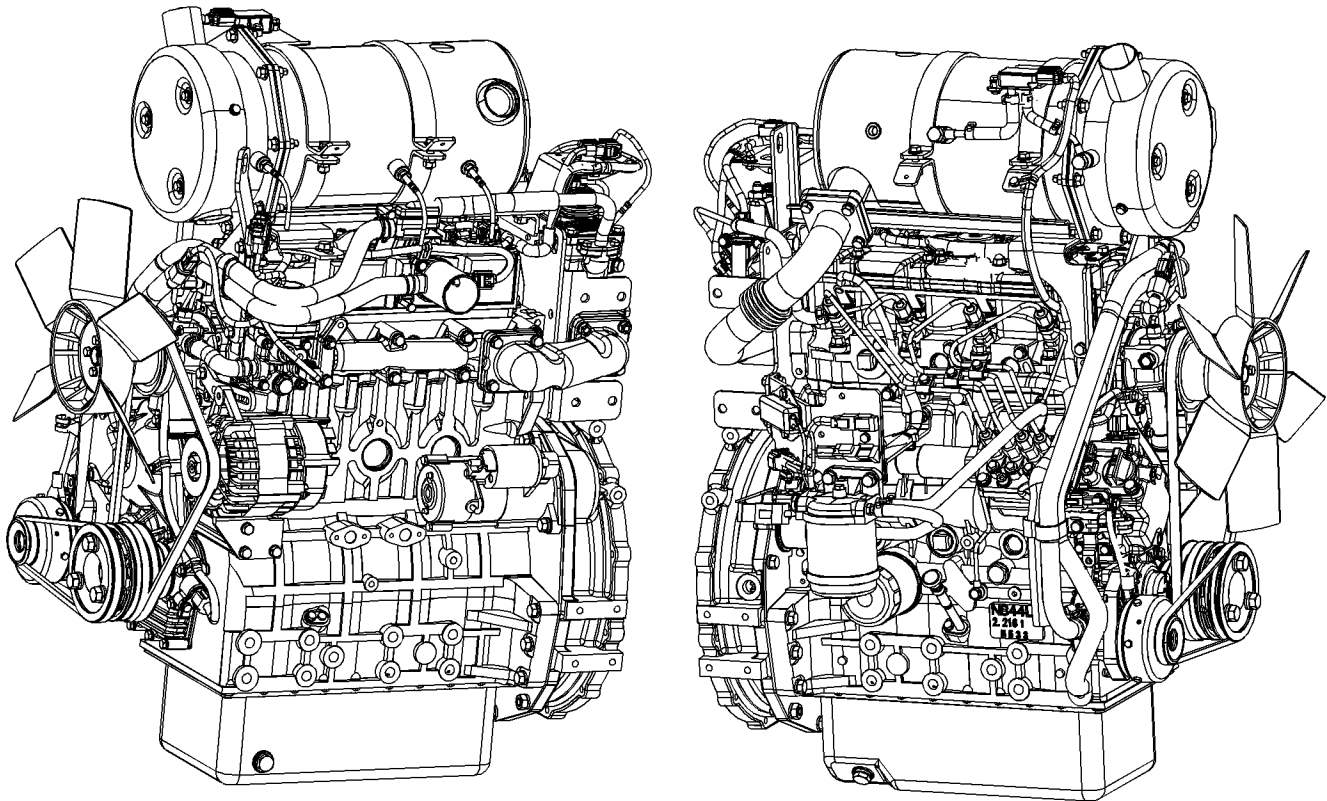

Illustration 20

g03321871

i05139813

Product Description

The 400F models are indirect injection engines. The fuel injection pump is operated by a solenoid that is controlled by a Pulse Width Modulation (PWM) signal from the ECM.

The cylinder head assembly has one inlet valve and one exhaust valve for each cylinder. Each cylinder valve has a single valve spring.

The pistons have two compression rings and an oil control ring. It is important to ensure the correct piston height so that the piston does not contact the cylinder head. The correct piston height also ensures efficient combustion of fuel that is necessary in order to conform to requirements for emissions.

The crankshaft for a three cylinder engine has four main bearing journals. The crankshaft for a four cylinder engine has five main bearing journals. End play is controlled by the thrust washers that are located on the rear main bearing.

The timing gears are stamped with timing marks in order to ensure the correct assembly of the gears. With the timing marks on the crankshaft gear camshaft gear and the idler gear aligned No. 1 piston will be at top center compression stroke.

The crankshaft gear turns the idler gear which then turns the camshaft gear and the gear for the engine oil pump.

The fuel injection pump is mounted in the cylinder block. The fuel injection pump is operated by the camshaft. The fuel pump is located on the right-hand side of the cylinder block. The fuel pump is electrically operated.

The fuel injection pump conforms to requirements for emissions. If any adjustments to the fuel injection pump timing and high idle are required, you must refer to your Perkins distributor your Perkins dealer.

A gerotor oil pump is located in the center of the idler gear. The engine oil pump sends lubricating oil to the main oil gallery through a pressure relief valve and an engine oil filter. The rocker arms receive pressurized oil through an externally located oil line that runs from the main oil gallery to the cylinder head.

Coolant from the bottom of the radiator passes through the belt driven centrifugal water pump. The coolant is cooled by the radiator and the temperature is regulated by a water temperature regulator.

Engine efficiency, efficiency of emission controls, and engine performance depend on adherence to correct operation and maintenance recommendations. Engine performance and efficiency also depend on the use of recommended fuels, lubrication oils, and coolants. Refer to the Operation and Maintenance Manual, "Maintenance Interval Schedule" for more information on maintenance items.

Engine Specifications

Note: The front end of the engine is opposite the flywheel end of the engine. The left and the right side of the engine are determined from the flywheel end. The No. 1 cylinder is the front cylinder.

403F-15T Engine

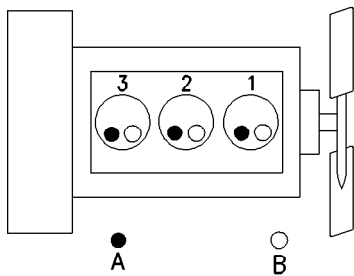

Illustration 21 g00852304
(A) Exhaust valves
(B) Inlet valves

Table 1

403F-15T Engine Specifications	
Maximum Operating Speed (rpm)	2800 rpm
Cylinders and Arrangement	In-Line 3 cylinder
Bore	84 mm (3.31 inch)
Stroke	90 mm (3.54 inch)

(continued)

(Table 1, contd)

Displacement	1.496 L (91.291 in ³)
Aspiration	T ⁽¹⁾
Compression Ratio	22.5:1
Firing Order	1-2-3
Rotation that is viewed from the flywheel	Counterclockwise
Valve Lash Setting (Inlet)	0.20 mm (0.008 inch)
Valve Lash Setting (Exhaust)	0.20 mm (0.008 inch)
Injection	Indirect

(1) Turbocharged

404F-22 Engine

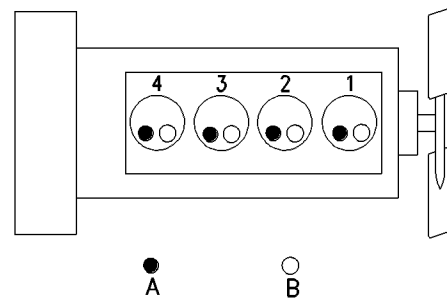

Illustration 22 g00296424
(A) Exhaust valves
(B) Inlet valves

Table 2

404F-22 Engine Specifications	
Maximum Operating Speed (rpm)	3000 rpm
Cylinders and Arrangement	In-Line 4 cylinder
Bore	84.0 mm (3.31 inch)
Stroke	100.0 mm (3.94 inch)
Displacement	2.216 L (135.229 in ³)
Aspiration	NA ⁽¹⁾
Compression Ratio	23.3:1
Firing Order	1-3-4-2
Rotation that is viewed from the flywheel	Counterclockwise

(continued)

(Table 2, contd)

Valve Lash Setting (Inlet)	0.20 mm (0.008 inch)
Valve Lash Setting (Exhaust)	0.20 mm (0.008 inch)
Injection	Indirect

(1) Naturally Aspirated

404F-22T Engine

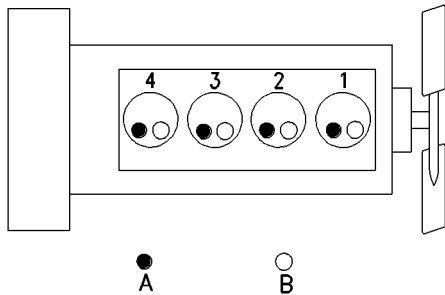

Illustration 23

g00296424

(A) Exhaust valves
(B) Inlet valves

Table 3

404F-22T Engine Specifications	
Maximum Operating Speed (rpm)	3000 rpm
Cylinders and Arrangement	In-Line 4 cylinder
Bore	84.0 mm (3.31 inch)
Stroke	100.0 mm (3.94 inch)
Displacement	2.216 L (135.229 in ³)
Aspiration	T ⁽¹⁾
Compression Ratio	23.5:1
Firing Order	1-3-4-2
Rotation that is viewed from the flywheel	Counterclockwise
Valve Lash Setting (Inlet)	0.20 mm (0.008 inch)
Valve Lash Setting (Exhaust)	0.20 mm (0.008 inch)
Injection	Indirect

(continued)

(Table 3, contd)

(1) Turbocharged

Electronic Engine Features

The engine operating conditions are monitored. The Electronic Control Module (ECM) controls the response of the engine to these conditions and to the demands of the operator. These conditions and operator demands determine the precise control of fuel injection by the ECM. The electronic engine control system provides the following features:

- Engine monitoring
- Engine speed governing
- System diagnostics
- Aftertreatment Regeneration
- NOx reduction system control on the 404F-22T engine

For more information on electronic engine features, refer to the Operation and Maintenance Manual, "Features and Controls" topic (Operation Section).

Engine Diagnostics

The engine has built-in diagnostics in order to ensure that the engine systems are functioning correctly. The operator will be alerted to the condition by a "Stop or Warning" lamp. Under certain conditions, the engine horsepower and the vehicle speed may be limited. The electronic service tool may be used to display the diagnostic codes.

There are four types of diagnostic codes: active code, logged code, active event and logged event.

Most of the diagnostic codes are logged and stored in the ECM. For additional information, refer to the Operation and Maintenance Manual, "Engine Diagnostics" topic (Operation Section).

The ECM provides an electronic governor that controls the injector output in order to maintain the desired engine rpm.

Engine Service Life

Engine efficiency and maximum utilization of engine performance depend on the adherence to proper operation and maintenance recommendations. In addition, use recommended fuels, coolants, and lubricants. Use the Operation and Maintenance Manual as a guide for required engine maintenance.

Expected engine life is generally predicted by the average power that is demanded. The average power that is demanded is based on fuel consumption of the engine over a period of time. Reduced hours of operation at full throttle and/or operating at reduced throttle settings result in a lower average power demand. Reduced hours of operation will increase the length of operating time before an engine overhaul is required.

Aftermarket Products and Perkins Engines

Perkins does not warrant the quality or performance of non-Perkins fluids and filters.

When auxiliary devices, accessories, or consumables (filters, additives, catalysts,) which are made by other manufacturers are used on Perkins products, the Perkins warranty is not affected simply because of such use.

However, failures that result from the installation or use of other manufacturers devices, accessories, or consumables are NOT Perkins defects. Therefore, the defects are NOT covered under the Perkins warranty.

Aftertreatment System

The aftertreatment system is approved for use by Perkins. In order to be emission-compliant only the approved Perkins aftertreatment system must be used on a Perkins engine.

Product Identification Information

i05140083

Plate Locations and Film Locations

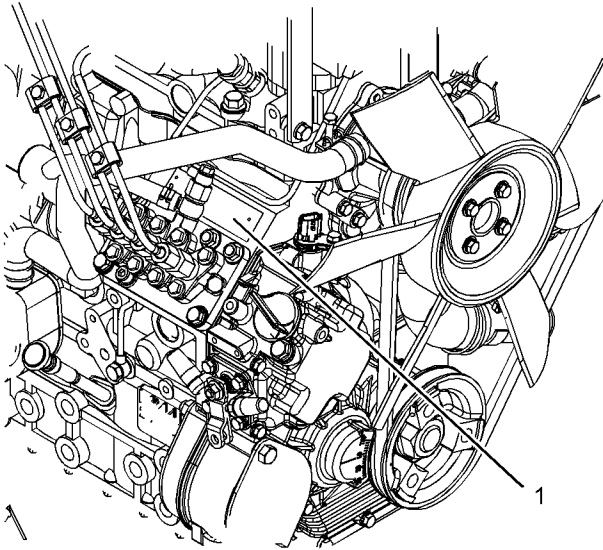

Illustration 24 g02335396

Typical example
(1) serial number plate

Perkins engines are identified by a serial number. This number is shown on a serial number plate. The serial number plate is mounted above the fuel injection pump on the right-hand side of the engine block.

An example of an engine number is ER****U000001V.

ER _____ Engine family

P _____ Type of engine

**** _____ The list number of the engine

U _____ Country of manufacture

0 _____ The first digit is a production code.

00001 _____ Engine Serial Number

V _____ Year of Manufacture

Perkins dealers or Perkins distributors need all of these numbers in order to determine the components that were included with the engine. This information permits accurate identification of replacement part numbers.

i07785792

Emissions Certification Film

EMISSION CONTROL INFORMATION	
PERKINS SMALL ENGINES LTD.	
ENGINE FAMILY	#####
POWER CATEGORY	#####
DISPLACEMENT	##### L
EMISSION-CONTROL SYSTEM	IFI ECM
USEFUL LIFE DEFINED BY	CARB: 5 YEARS OR 3000h
DATE OF MANUFACTURE:	#####
THIS ENGINE CONFORMS TO 2013 U.S. EPA AND CALIFORNIA REGULATIONS FOR LARGE NON-ROAD STATIONARY COMPRESSION-IGNITION ENGINES	
ULTRA LOW SULFUR FUEL ONLY	
EC TYPE- APPROVAL No:	#####
#####	#####

Illustration 26 g06435423

Typical example



Illustration 25 g01094203

Typical example



Illustration 27

g02157153

Typical example

Illustration 27 is a representation of the label that will be installed next to the fuel filler cap on the fuel tank of the application.

i05157330

Reference Information

Information for the following items may be needed to order parts. Locate the information for your engine. Record the information in the appropriate space. Make a copy of this list for a record. Keep the information for future reference.

Record for Reference

Engine Model _____

Engine Serial number _____

Engine rpm _____

In-Line fuel filter _____

Fuel Filter Element _____

Lubrication Oil Filter _____

Crankcase Breather Element _____

Total Lubrication System Capacity _____

Total Cooling System Capacity _____

Air Cleaner Element _____

Fan Belt _____

Belt for Air Pump _____

Identifying Numbers on Aftertreatment _____

Operation Section

Lifting and Storage

i07436259

Product Lifting

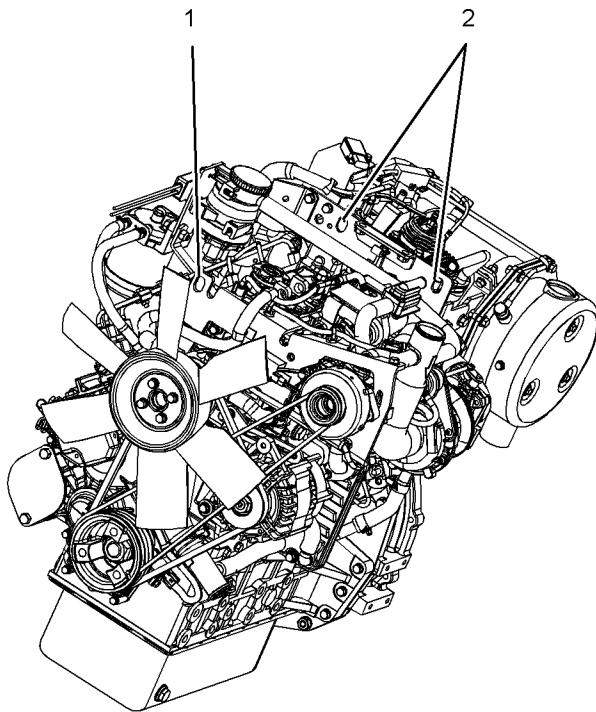

Illustration 28

g03274116

Typical example

- (1) Front lifting eye
- (2) Rear lifting eyes

NOTICE

Always inspect lifting eyebolts and all other lifting equipment for damage before performing any lifting. Never Bend the eyebolts and the brackets. Never perform product lifting if the components are damaged.

Note: The engine assembly has three lifting eyes, refer to illustration 28 .

Use a hoist to remove heavy components. Use an adjustable lifting beam to lift the engine. All supporting members (chains and cables) should be parallel to each other. The chains and cables should be perpendicular to the top of the object that is being lifted.

To remove the engine ONLY, use the lifting eyes that are on the engine.

Lifting eyes are designed and installed for specific engine arrangements. Alterations to the lifting eyes and/or the engine make the lifting eyes and the lifting fixtures obsolete. If alterations are made, ensure that correct lifting devices are provided. Consult your Perkins dealer or your Perkins distributor for information regarding fixtures for correct engine lifting.

Lifting Eyes with Top Mounted Aftertreatment

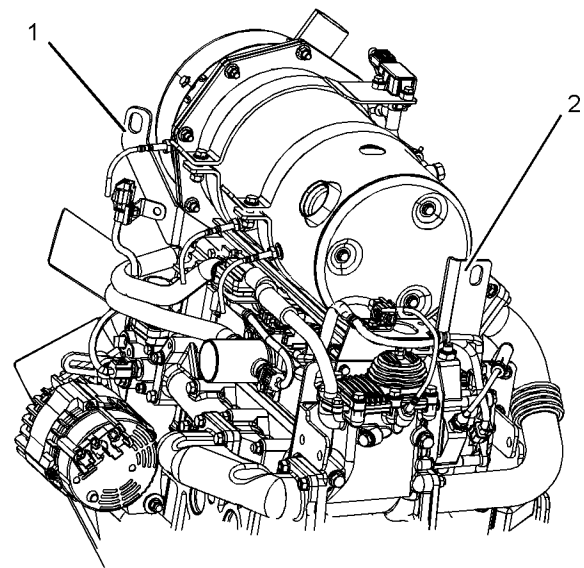

Illustration 29

g03321882

- (1) Front lifting eye
- (2) Rear lifting eye

i04053009

Product Storage (Engine and Aftertreatment)

Perkins are not responsible for damage which may occur when an engine is in storage after a period in service.

Your Perkins dealer or your Perkins distributor can assist in preparing the engine for extended storage periods.

Condition for Storage

The engine must be stored in a water proof building. The building must be kept at a constant temperature. Engines that are filled with Perkins ELC will have coolant protection to an ambient temperature of -36°C (-32.8°F). The engine must not be subjected to extreme variations in temperature and humidity.

Storage Period

An engine can be stored for up to 6 months provided all the recommendation are adhered to.

Storage Procedure

Keep a record of the procedure that has been completed on the engine.

Note: Do not store an engine that has biodiesel in the fuel system.

1. Ensure that the engine is clean and dry.
 - a. If the engine has been operated using biodiesel, the system must be drained and new filters installed. The fuel tank will require flushing.
 - b. Fill the fuel system with an ultra low sulfur fuel. For more information on acceptable fuels refer to this Operation and Maintenance Manual, "Fluid recommendations". Operate the engine for 15 minutes in order to remove all biodiesel from the system.
2. Drain any water from the primary filter water separator. Ensure that the fuel tank is full.
3. The engine oil will not need to be drained in order to store the engine. Provided the correct specification of engine oil is used the engine can be stored for up to 6 months. For the correct specification of engine oil refer to this Operation and Maintenance Manual, "Fluid recommendations".
4. Remove the drive belts from the engine.

Sealed Coolant System

Ensure that the cooling system is filled with Perkins ELC, or an antifreeze that meets "ASTM D6210" specification.

Open Cooling System

Ensure that all cooling drain plugs have been opened. Allow the coolant to drain. Install the drain plugs. Place a vapor phase inhibitor into the system. The coolant system must be sealed once the vapor phase inhibitor has been introduced. The effect of the vapor phase inhibitor will be lost if the cooling system is open to the atmosphere.

For maintenance procedures ref to this Operation and Maintenance Manual.

Aftertreatment

No special procedures are required. The exhaust outlet of the aftertreatment should be capped. Before storing, the engine and the aftertreatment must be enclosed in a cover.

Monthly Checks

The crankshaft must be rotated in order to change the spring loading on the valve train. Rotate the crankshaft more than 180 degrees. Visibly check for damage or corrosion to the engine and aftertreatment.

Ensure that the engine and aftertreatment are covered completely before storage. Log the procedure in the record for the engine.

Features and Controls

i05142391

Alarms and Shutoffs

- ECM_____Electronic Control Module
- DOC_____Diesel Oxidation Catalyst
- DPF_____Diesel Particulate Filter
- ARD_____Aftertreatment Regeneration Device

Shutoffs

The shutoffs are electrically operated or mechanically operated. The electrically operated shutoffs are controlled by the ECM.

Shutoffs are set at critical levels for the following items:

- Operating temperature
- Operating RPM
- Overspeed
- Aftertreatment regeneration

The particular shutoff may need to be reset before the engine will start.

NOTICE

Always determine the cause of the engine shutdown. Make necessary repairs before attempting to restart the engine.

Be familiar with the following items:

- Types and locations of shutoff
- Conditions which cause each shutoff to function
- The resetting procedure that is required to restart the engine

Alarms

The alarms are electrically operated. The operations of the alarms are controlled by the ECM.

The alarm is operated by a sensor or by a switch. When the sensor or the switch is activated, a signal is sent to the ECM. An event code is created by the ECM. The ECM will send a signal in order to illuminate the lamp. Some application may have a display panel in order to alert the operator.

Your engine may be equipped with the following sensors or switches:

Coolant temperature – The coolant temperature sensor indicates high jacket water coolant temperature.

Engine oil pressure – The engine oil pressure sensor or switch, indicates when oil pressure drops below rated system pressure, at a set engine speed.

Boost pressure (Intake manifold pressure) – The intake manifold pressure sensor checks the rated pressure in the engine manifold.

Intake manifold air temperature – The intake manifold air temperature sensor indicates high intake air temperature.

Atmospheric pressure – The atmospheric pressure sensor checks the air pressure in the location that the engine is operating.

Aftertreatment Alarms

DOC inlet temperature – The inlet temperature sensor checks the operating temperature.

DPF inlet temperature – The inlet temperature sensor checks the operating temperature.

DPF outlet temperature – The outlet temperature sensor checks the operating temperature.

Delta P sensor (Differential pressure) – The sensor checks the differential pressure within the system.

ARD temperature – The sensor checks the temperature within the burner in the ARD system

Testing

Turning the keyswitch to the ON position will check the indicator lights on the control panel. All the indicator lights will be illuminated for 2 seconds after the keyswitch is operated. Replace suspect bulbs immediately.

If any lamps stay illuminated or flashes, the fault must be investigated immediately. The fault will create a diagnostic code.

Refer to Troubleshooting, “Diagnostic Trouble Code” for more information.

i05140291

Gauges and Indicators

Your engine may not have the same gauges or all of the gauges that are described. For more information about the gauge package, see the OEM information.

Gauges provide indications of engine performance. Ensure that the gauges are in good working order. Determine the normal operating range by observing the gauges over a period of time.

Noticeable changes in gauge readings indicate potential gauge or engine problems. Problems may also be indicated by gauge readings that change even if the readings are within specifications. Determine and correct the cause of any significant change in the readings. Consult your Perkins dealer or your Perkins distributor for assistance.

NOTICE

If no oil pressure is indicated, STOP the engine. If maximum coolant temperature is exceeded, STOP the engine. Engine damage can result.



Engine Oil Pressure – The oil pressure should be greatest after a cold engine is started. The typical engine oil pressure with SAE10W30 is 207 to 413 kPa (30 to 60 psi) at rated rpm.

A lower oil pressure is normal at low idle. If the load is stable and the gauge reading changes, perform the following procedure:

1. Remove the load.
2. Reduce engine speed to low idle.
3. Check and maintain the oil level.



Jacket Water Coolant Temperature – Typical temperature range is 71 to 96°C (160 to 205°F). The maximum allowable temperature with the pressurized cooling system at 90 kPa (13 psi) is 125° C (257° F). Higher temperatures may occur under certain conditions. The water temperature reading may vary according to load. The reading should never exceed the boiling point for the pressurized system that is being used.

If the engine is operating above the normal range and steam becomes apparent, perform the following procedure:

1. Reduce the load and the engine rpm.
2. Inspect the cooling system for leaks.
3. Determine if the engine must be shut down immediately or if the engine can be cooled by reducing the load.



Tachometer – This gauge indicates engine speed (rpm). When the throttle control lever is moved to the full throttle position without load, the engine is running at high idle. The engine is running at the full load rpm when the throttle control lever is at the full throttle position with maximum rated load.

NOTICE

To help prevent engine damage, never exceed the high idle rpm. Overspeeding can result in serious damage to the engine. The engine can be operated at high idle without damage, but should never be allowed to exceed high idle rpm.



Ammeter – This gauge indicates the amount of charge or discharge in the battery charging circuit. Operation of the indicator should be to the right side of “0” (zero).



Fuel Level – This gauge indicates the fuel level in the fuel tank. The fuel level gauge operates when the “START/STOP” switch is in the “ON” position.



Service Hour Meter – The gauge indicates operating time of the engine.

Indicators and Lamps

- Shutdown lamp
- Warning lamp
- Low-pressure oil lamp

For more information on indicator lamps refer to this Operation and Maintenance Manual, “Monitoring System (Table for Indicators Lamps)”. All lamps will be illuminated for 2 seconds in order to check that the lamps are functioning when the keyswitch is turned to the ON position. Any lamp that fails to illuminate during the first 2 second must be replaced. If any of the lamps stay illuminated, the reason must be investigated immediately.

Aftertreatment Lamps

There are three aftertreatment lamps.

- Regeneration Active Lamp
- Regeneration Disabled Lamp
- Diesel Particulate Filter (DPF) Lamp

For information on the aftertreatment lamps and warning lamps refer to this Operation and Maintenance Manual, "Diesel Particulate Filter Regeneration"

i05113371

Monitoring System (Engine Warning Indicators)

Table 4

Table for Warning Indicators					
Warning Indicator	Shutdown Indicator	Indicator State	Description of the Indication	Engine Status	Operator Action
ON	ON	Indicator Check	Keyswitch in the ON position all Indicators should illuminate for 2 seconds.	Power ON, Indicator check Engine is not operating.	If any of the Indicators will not illuminate during the Indicator check, the fault must be investigated immediately. If any Indicator stay illuminated or flash, the fault must be investigated immediately.
The aftertreatment Indicators will also be checked during Indicator check.					
OFF	OFF	No Fault	-	Engine operating normally.	None
Level 1					
ON (Solid)	OFF	Level 1	An active diagnostic code is present.	The engine is operating, but one or more diagnostic codes are present.	As soon as possible the diagnostic code should be investigated.
Level 2					
Flashing	OFF	Level 2	The ECM has detected an abnormal condition.	If enabled, the engine will be derated.	Stop the engine. Investigate the fault.
Level 3					
Flashing	ON	Level 3	Engine condition is abnormal.	The engine will automatically shut down. If shut down is not enabled, the engine can operate until damage is caused.	Stop engine immediately. Investigate the fault.

i05182480

Monitoring System

WARNING

If the Shutdown mode has been selected and the warning indicator activates, engine shutdown may take as little as 20 seconds from the time the warning indicator is activated. Depending on the application, special precautions should be taken to avoid personal injury. The engine can be re-started following shutdown for emergency maneuvers, if necessary.

NOTICE

The Engine Monitoring System is not a guarantee against catastrophic failures. Programmed delays and derate schedules are designed to minimize false alarms and provide time for the operator to stop the engine.

The following parameters are monitored:

- Coolant temperature
- Intake manifold air pressure
- Oil pressure
- Engine speed/timing
- Atmospheric pressure (Barometric pressure) if equipped
- The amount of soot in the Diesel particulate filter
- Battery voltage

Programmable Options and Systems Operation

WARNING

If the Warning/Derate/Shutdown mode has been selected and the warning indicator activates, bring the engine to a stop whenever possible. Depending on the application, special precautions should be taken to avoid personal injury.

The engine can be programmed to the following modes:

“Warning”

The orange “Warning” lamp will turn “ON” and the warning signal is activated continuously in order to alert the operator that one or more of the engine parameters is not within normal operating range.

“Derate”

The orange “Warning” lamp will be “Flashing”. After the warning, the engine power will be derated. The warning lamp will begin to flash when the derating occurs.

The engine will be derated if the engine exceeds preset operational limits. The engine derate is achieved by restricting the amount of fuel that is available for each injection. The amount of this reduction of fuel is dependent on the severity of the fault that has caused the engine derate, typically up to a limit of 50%. This reduction in fuel results in a predetermined reduction in engine power.

“Shutdown”

The orange warning will be “Flashing”. After the warning, the engine power will be derated. The engine will continue at the rpm of the set derate until a shutdown of the engine occurs. After shutdown the red stop lamp will illuminate. The engine can be restarted after a shutdown for use in an emergency.

A shutdown of the engine after been triggered is immediate. The engine can be restarted after a shutdown for use in an emergency. However, the cause of the initial shutdown may still exist.

If there is a signal for high coolant temperature, there will be a 2 second delay in order to verify the condition.

If there is a signal for low oil pressure, there will be a 2 second delay in order to verify the condition.

For information on the operation of the warning lamps and the shutdown lamp, refer to this Operation and Maintenance Manual, “Monitoring System (Table for Indicator Lamps)”. For each of the programmed modes, refer to Troubleshooting Guide, “Indicator Lamps” for more information on Indicator Lamps.

For more information or assistance for repairs, consult your Perkins dealer or your Perkins distributor.

i05182498

Overspeed

- 403F-15T _____ 3000 RPM
- 404F-22 _____ 3000 RPM
- 404F-22T _____ 3000 RPM

The overspeed is plus 700 RPM above the given speed for engines shown.

i05142078

Sensors and Electrical Components (Engine and Aftertreatment)

- ARD _____ Aftertreatment Regeneration Device
- DOC _____ Diesel Oxidation Catalyst
- DPF _____ Diesel Particulate Filter
- ECM _____ Electronic Control Module
- NRS _____ NOx Reduction System

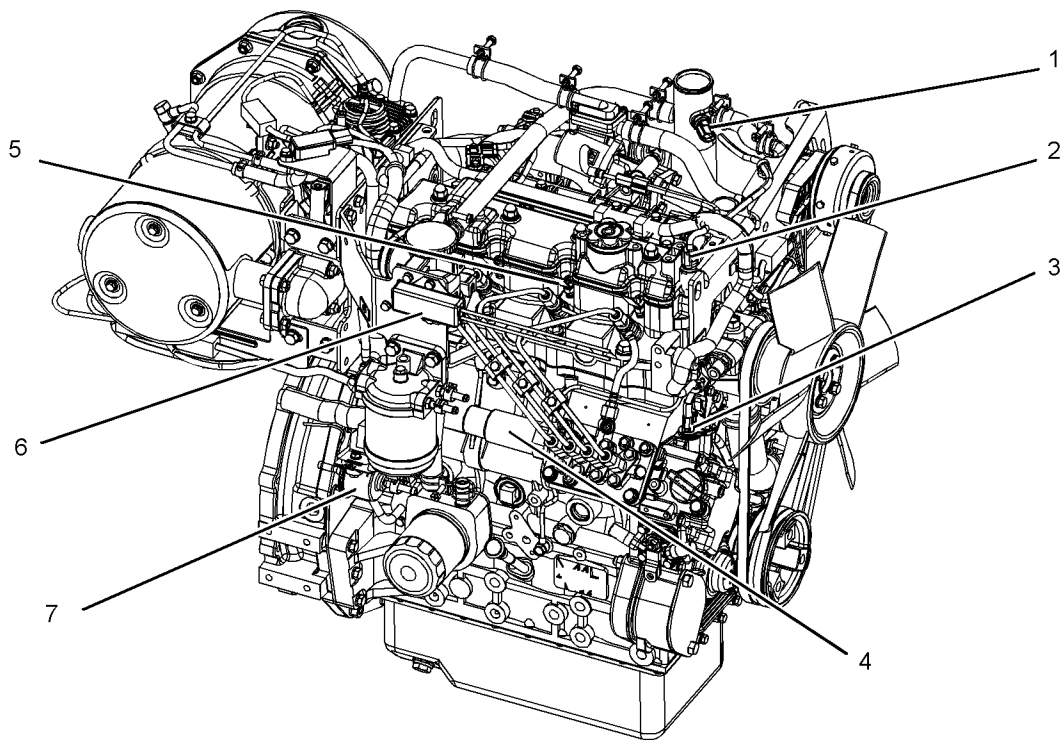

Illustration 30

g03276099

(1) Inlet air temperature sensor
 (2) Oil pressure switch
 (3) Secondary speed sensor

(4) Fuel rack solenoid and position sensor
 (5) Glow plugs
 (6) Resistor for ARD glow plug

(7) Fuel pump/Priming pump

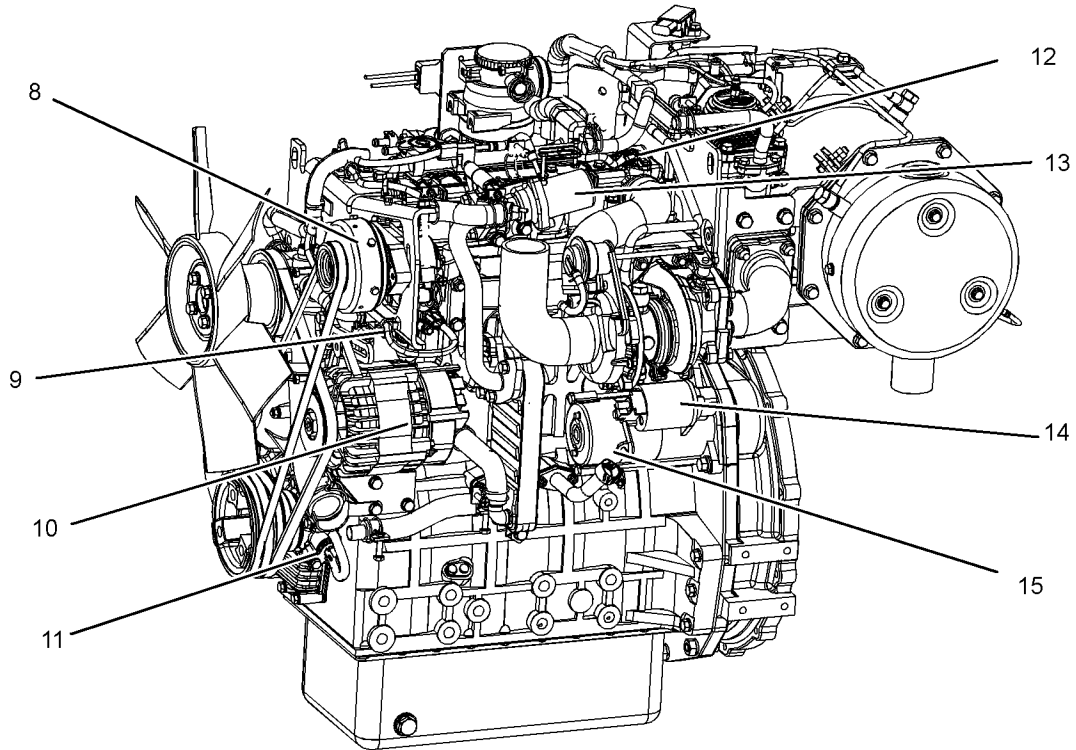

Illustration 31

g03276102

(8) Air pump
(9) Coolant temperature sensor
(10) Alternator

(11) Primary speed sensor
(12) Inlet manifold air pressure sensor
(13) NRS control valve

(14) Solenoid for starting motor
(15) Starting motor

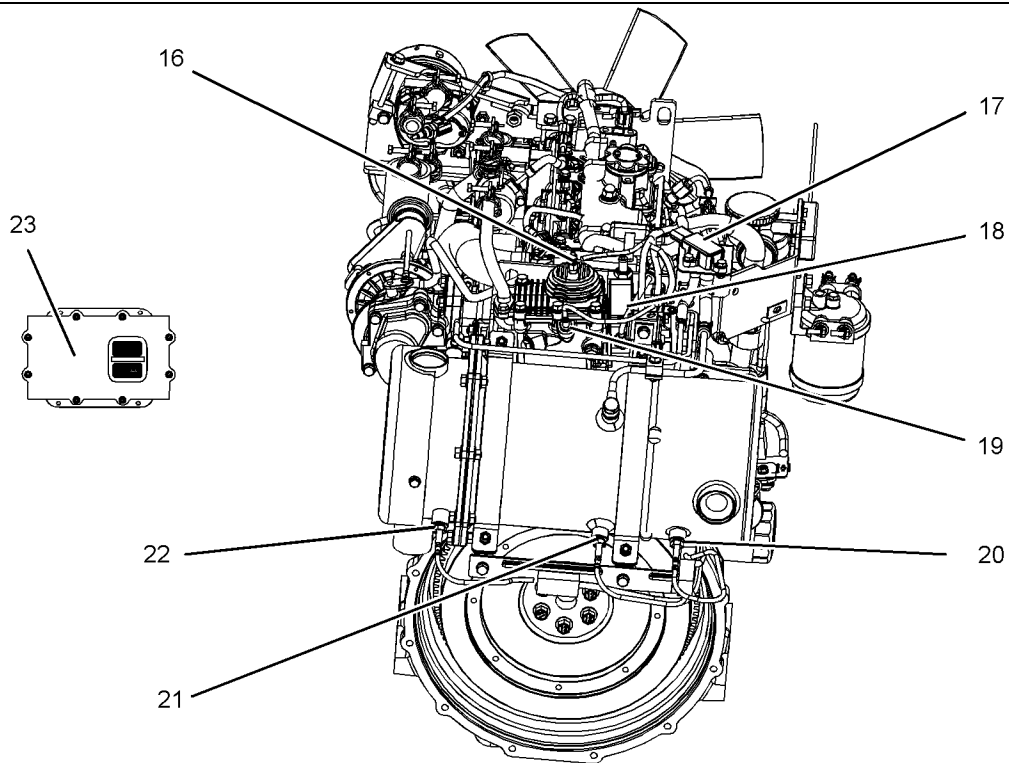

Illustration 32

g03279116

(16) ARD glow plug
(17) DPF pressure differential sensor
(18) ARD injectors

(19) ARD temperature sensor
(20) DOC intake temperature sensor
(21) DPF intake temperature sensor

(22) DPF outlet temperature sensor
(23) ECM

The ECM is remotely mounted. The position of ECM will depend upon the application.

Operation Section
Engine and Aftertreatment

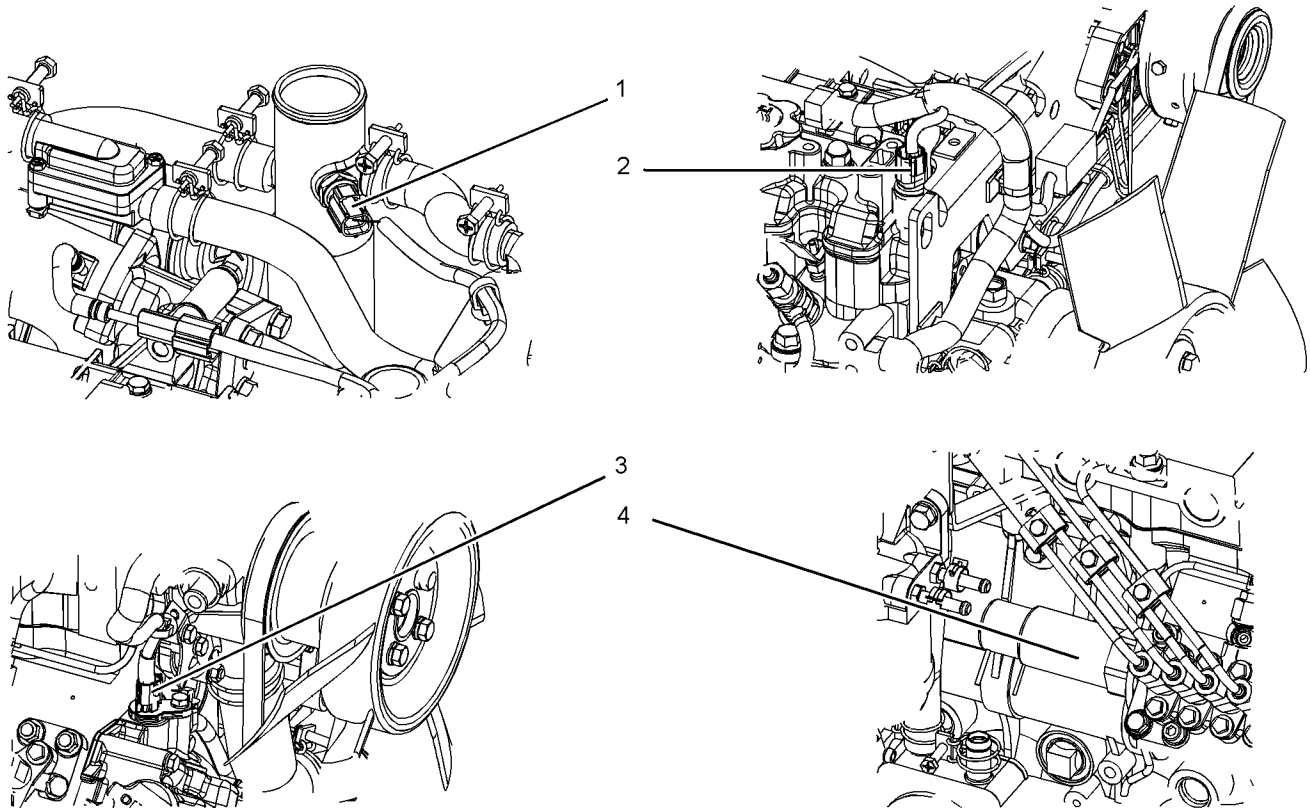

Illustration 33

g03279862

(1) Inlet air temperature
(2) Oil pressure switch

(3) Secondary speed sensor
(4) Fuel rack solenoid and position sensor

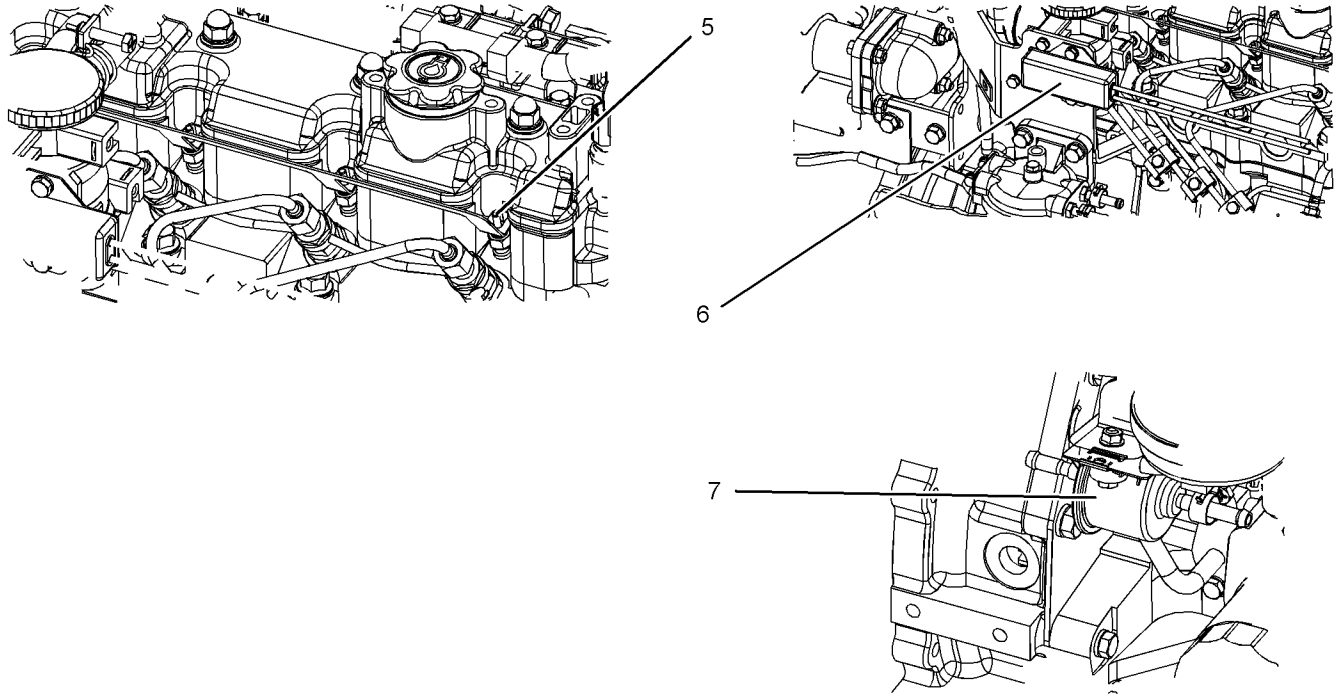

Illustration 34

g03280057

(5) Glow plugs

(6) Resistor for ARD glow plug

(7) Fuel pump/Priming pump

Operation Section
Engine and Aftertreatment

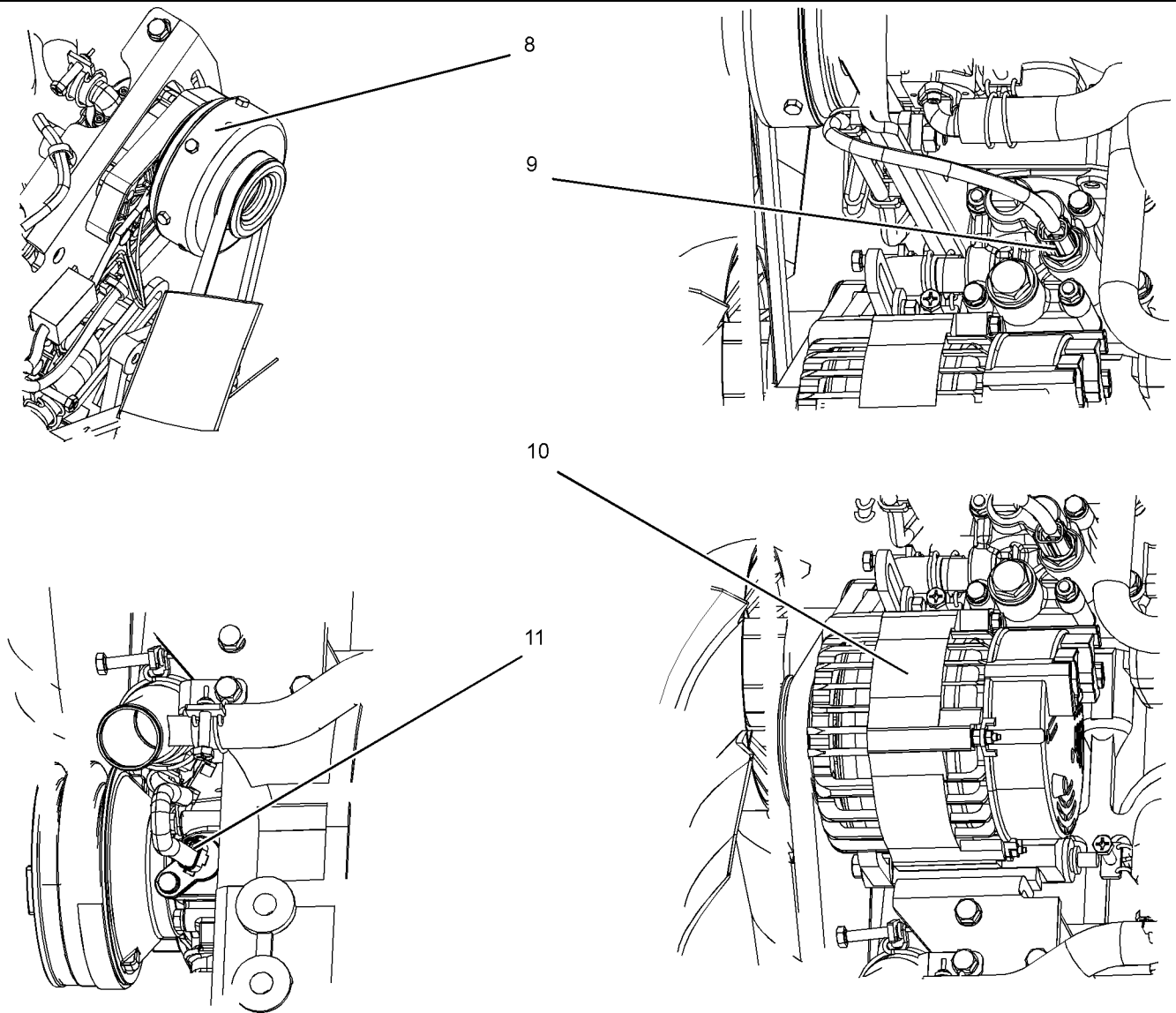

Illustration 35

g03299376

- (8) Air pump
- (9) Coolant temperature sensor

- (10) Alternator
- (11) Primary speed sensor

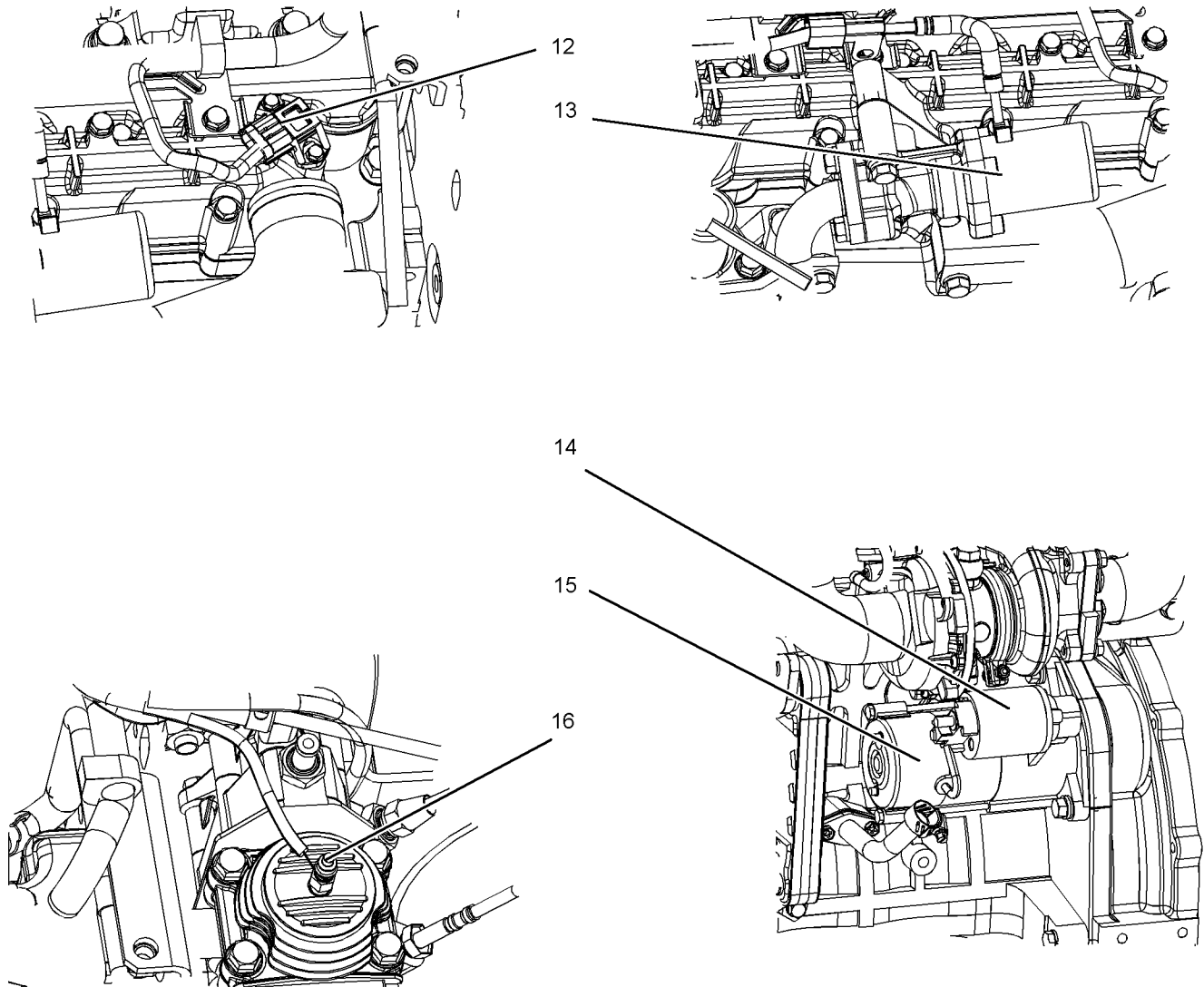

Illustration 36

(12) Inlet manifold air pressure sensor
(13) NRS control valve

(14) Solenoid for starting motor
(15) Starting motor

(16) ARD glow plug

g03299456

Operation Section
Engine and Aftertreatment

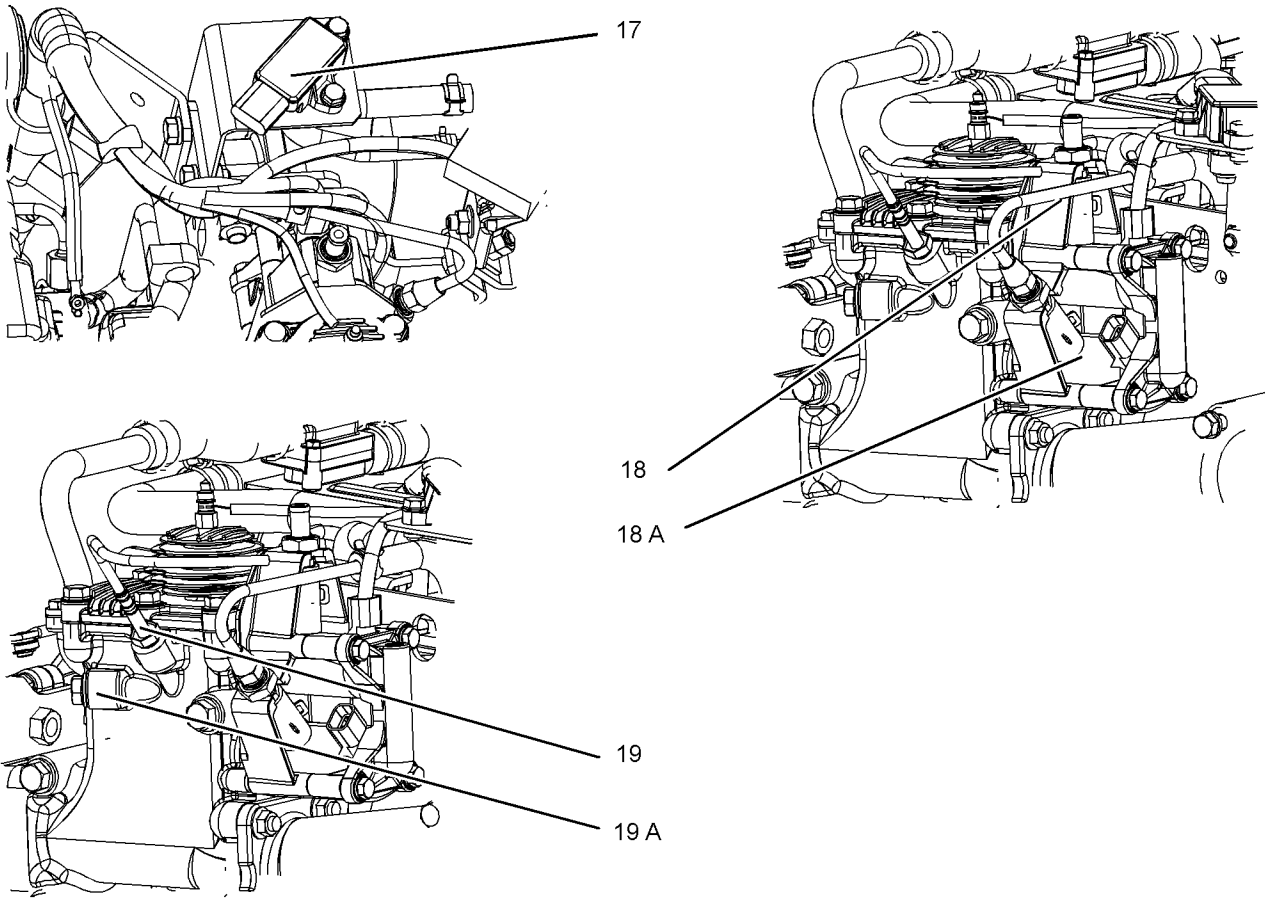

Illustration 37

g03299640

(17) DPF pressure differential sensor
(18) ARD injector 1

(18 A) ARD injector 2
(19) ARD temperature sensor

(19 A) Alternative position for the ARD
temperature sensor

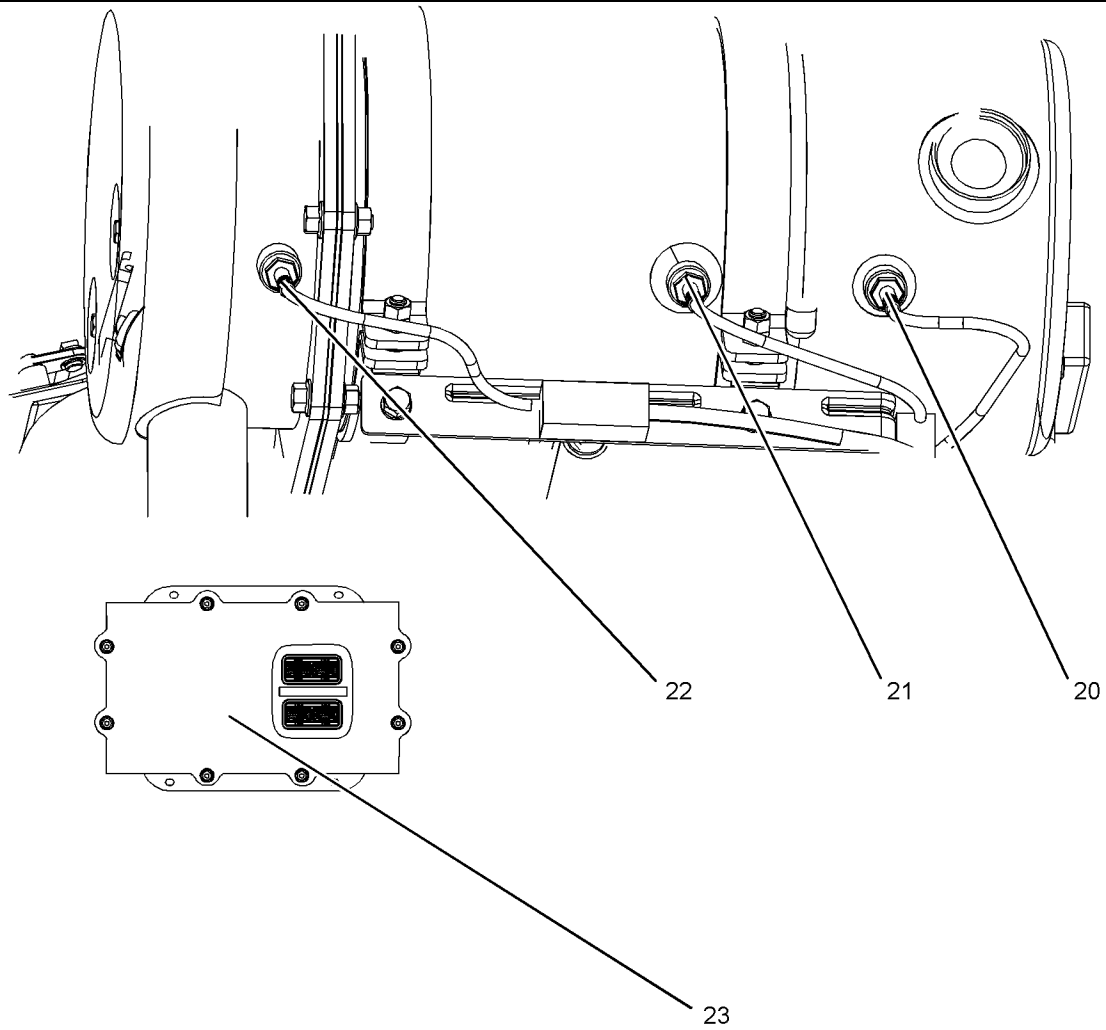

Illustration 38

g03299676

(20) DOC intake temperature sensor
(21) DPF intake temperature sensor

(22) DPF outlet temperature sensor
(23) ECM

Engine Diagnostics

i05142509

Self-Diagnostics

i04053178

Perkins electronic engines have the capability to perform a self-diagnostics test. When the system detects an active problem, a diagnostic lamp is activated. Diagnostic codes will be stored in permanent memory in the Electronic Control Module (ECM). The diagnostic codes can be retrieved by using the electronic service tool. Refer to Troubleshooting , “Electronic Service Tools” for further information.

Some installations have electronic displays that provide direct readouts of the engine diagnostic codes. Refer to the manual that is provided by the OEM for more information on retrieving engine diagnostic codes. Alternatively refer to Troubleshooting , “Indicator Lamps” for further information.

Active codes represent problems that currently exist. These problems should be investigated first.

Logged codes represent the following items:

- Intermittent problems
- Recorded events
- Performance history

The problems may have been repaired since the logging of the code. These codes do not indicate that a repair is needed. The codes are guides or signals when a situation exists. Codes may be helpful to troubleshoot problems.

When the problems have been corrected, the corresponding logged fault codes should be cleared.

i04053182

Diagnostic Lamp

A diagnostic lamp is used to indicate the existence of an active fault. Refer to Troubleshooting , “Indicator Lamps” for more information. A fault diagnostic code will remain active until the problem is repaired. The diagnostic code may be retrieved by using the electronic service tool. Refer to Troubleshooting , “Electronic Service Tools” for more information.

Fault Logging

The system provides the capability of Fault Logging. When the Electronic Control Module (ECM) generates an active diagnostic code, the code will be logged in the memory of the ECM. The codes that have been logged by the ECM can be identified by the electronic service tool. The active codes that have been logged will be cleared when the fault has been rectified or the fault is no longer active.

i06748909

Engine Operation with Active Diagnostic Codes

If a diagnostic lamp illuminates during normal engine operation, the system has identified a situation that is not within the specification. Use electronic service tools to check the active diagnostic codes.

Note: The power may be limited until the problem is corrected. If the oil pressure is within the normal range, the engine may be operated at the rated speed and load. However, maintenance should be performed as soon as possible.

The active diagnostic code should be investigated. The cause of the problem should be corrected as soon as possible. If the cause of the active diagnostic code is repaired and there is only one active diagnostic code, the diagnostic lamp will turn off.

Operation of the engine and performance of the engine can be limited as a result of the active diagnostic code that is generated. Acceleration rates may be significantly slower. Refer to the Troubleshooting for more information on the relationship between these active diagnostic codes and engine performance.

i04053849

Engine Operation with Intermittent Diagnostic Codes

If a diagnostic lamp illuminates during normal engine operation and the diagnostic lamp shuts off, an intermittent fault may have occurred. If a fault has occurred, the fault will be logged into the memory of the Electronic Control Module (ECM).

In most cases, stopping the engine will not be necessary because of an intermittent code. However, the operator should retrieve the logged fault codes and the operator should reference the appropriate information in order to identify the nature of the event. The operator should log any observation that could have caused the lamp to light.

- Low power
- Limits of the engine speed
- Engine vibration or engine noise

This information can be useful to help troubleshoot the situation. The information can also be used for future reference. For more information on diagnostic codes, refer to the Troubleshooting Guide for this engine.

i05142533

Configuration Parameters

System configuration parameters affect the emissions of the engine or the power of the engine. System configuration parameters are programmed at the factory. Normally, system configuration parameters would never change through the life of the engine. System configuration parameters must be reprogrammed if an Electronic Control Module (ECM) is replaced. System configuration parameters are not reprogrammed if the ECM software is changed.

For more information, refer to Troubleshooting, "System Configuration Parameters".

Engine Starting

i04053911

Before Starting Engine

Perform the required daily maintenance and other periodic maintenance before the engine is started. Inspect the engine compartment. This inspection can help prevent major repairs at a later date. Refer to the Operation and Maintenance Manual, "Maintenance Interval Schedule" for more information.

- Ensure that the engine has an adequate fuel supply.
- Open the fuel supply valve (if equipped).

If the engine has not been started for several weeks, fuel may have drained from the fuel system. Air may have entered the filter housing. Also, when fuel filters have been changed, some air pockets will be trapped in the engine. In these instances, prime the fuel system. Refer to the Operation and Maintenance Manual, "Fuel System - Prime" for more information on priming the fuel system. Also, check that the fuel specification is correct and that the fuel condition is correct. Refer to the Operation and Maintenance Manual, "Fuel Recommendations".

WARNING

Engine exhaust contains products of combustion which may be harmful to your health. Always start and operate the engine in a well ventilated area and, if in an enclosed area, vent the exhaust to the outside.

- Do not start the engine or move any of the controls if there is a "DO NOT OPERATE" warning tag or similar warning tag attached to the start switch or to the controls.
- Reset all of the shutoffs or alarm components.
- Ensure that any driven equipment has been disengaged. Minimize electrical loads or remove any electrical loads.

i05144913

Cold Weather Starting

WARNING

Do not use aerosol types of starting aids such as ether. Such use could result in an explosion and personal injury.

The ability to start the engine will be improved at temperatures below -18°C (0°F) from the use of a jacket water heater or extra battery capacity.

When Group 2 diesel fuel is used, the following items provide a means of minimizing starting problems and fuel problems in cold weather: Engine oil pan heaters, jacket water heaters, fuel heaters and fuel line insulation.

Use the procedure that follows for cold weather starting.

Note: Do not adjust the engine speed control during start-up. The electronic control module (ECM) will control the engine speed during start-up.

1. Disengage any driven equipment.

Note: During key ON, the indicator lamps will be illuminated for 2 seconds in order to check the lamp operation. If any of the indicator lamps do not illuminate check the bulb. If any indicator lamps stay illuminated or flash, refer to Troubleshooting, "Indicator Lamp Circuit - Test".

2. Turn the keyswitch to the RUN position. Leave the keyswitch in the RUN position until the warning light for the glow plugs is extinguished.
3. When the warning light for the glow plugs is extinguished, turn the keyswitch to the START position in order to engage the electric starting motor and crank the engine.

Note: The operating period of the warning light for the glow plugs will change due to the ambient air temperature.

NOTICE

Do not engage the starting motor when flywheel is turning. Do not start the engine under load.

If the engine fails to start within 30 seconds, release the starter switch or button and wait two minutes to allow the starting motor to cool before attempting to start the engine again.

4. Allow the keyswitch to return to the RUN position after the engine starts.
5. Repeat step 2 through step 4 if the engine fails to start.

Note: The engine should not be "raced" in order to speed up the warm-up process.

6. Allow the engine to idle for 3 to 5 minutes, or allow the engine to idle until the water temperature indicator begins to rise. When idling after the engine has started in cold weather, increase the engine rpm from 1000 to 1200 rpm. This operation will warm up the engine more quickly. Maintaining an elevated low idle speed for extended periods will be easier with the installation of a hand throttle. Allow the white smoke to disperse before proceeding with normal operation.
7. Operate the engine at low load until all systems reach operating temperature. Check the gauges during the warm-up period.

i05142649

Starting the Engine

WARNING

Do not use aerosol types of starting aids such as ether. Such use could result in an explosion and personal injury.

Note: Do not adjust the engine speed control during start-up. The electronic control module (ECM) will control the engine speed during start-up.

Starting the Engine

1. Disengage any equipment that is driven by the engine.

Note: During key ON, the indicator lamps will be illuminated for 2 seconds in order to check the lamp operation. If any of the indicator lamps do not illuminate check the bulb. If any indicator lamps stay illuminated or flash, refer to Troubleshooting, "Indicator Lamp Circuit - Test".

2. Turn the keyswitch to the RUN position. Leave the keyswitch in the RUN position until the warning light for the glow plugs is extinguished.
3. When the warning light for the glow plugs has been extinguished turn the keyswitch to the START position. The starter motor will then crank the engine.

Note: The operating period of the warning light for the glow plugs will change due to the ambient air temperature.

NOTICE

Do not engage the starting motor when flywheel is turning. Do not start the engine under load.

If the engine fails to start within 30 seconds, release the starter switch or button and wait two minutes to allow the starting motor to cool before attempting to start the engine again.

4. Allow the keyswitch to return to the RUN position after the engine starts.
5. Repeat step 2 through step 4 if the engine fails to start.

i08134367

Starting with Jump Start Cables

(Do Not Use This Procedure in Hazardous Locations that have Explosive Atmospheres)

WARNING

The connection of battery cables to a battery and the disconnection of battery cables from a battery may cause an explosion which may result in injury or death. The connection and the disconnection of other electrical equipment may also cause an explosion which may result in injury or death. The procedures for the connection and the disconnection of battery cables and other electrical equipment should only be performed in a nonexplosive atmosphere.

WARNING

Improper jump start cable connections can cause an explosion resulting in personal injury.

Prevent sparks near the batteries. Sparks could cause vapors to explode. Do not allow jump start cable ends to contact each other or the engine.

Note: If possible, first diagnose the reason for the starting failure. Refer to Troubleshooting, "Engine Will Not Crank and Engine Cranks But Will Not Start" for further information. Make any necessary repairs. If the engine will not start only due to the condition of the battery, either charge the battery, or start the engine by using another battery with jump-start cables. The condition of the battery can be rechecked after the engine has been switched OFF.

NOTICE

Never attempt to start an engine from an external power source such as electric welding equipment, which has a voltage that is unsuitable for engine starting and will damage the electrical system.

For 904D-E28T industrial engines, use a 12 VDC battery source to start the engine.

For 904D-E36TA industrial engines, ensure that a 12 VDC or 24 VDC battery source is used to start the engine.

NOTICE

Using a battery source with the same voltage as the electric starting motor. Use **ONLY** equal voltage for jump starting. The use of higher voltage will damage the electrical system.

Do not reverse the battery cables. The alternator can be damaged. Attach ground cable last and remove first.

Turn all electrical accessories OFF before attaching the jump start cables.

Ensure that the main power switch is in the OFF position before attaching the jump start cables to the engine being started.

1. Turn the start switch on the stalled engine to the OFF position. Turn off all the engines accessories.
2. Connect one positive end of the jump-start cable to the positive cable terminal of the discharged battery. Connect the other positive end of the jump-start cable to the positive cable terminal of the electrical source.
3. Connect one negative end of the jump-start cable to the negative cable terminal of the electrical source. Connect the other negative end of the jump-start cable to the engine block or to the chassis ground. This procedure helps to prevent potential sparks from igniting the combustible gases that are produced by some batteries.

Note: The engine ECM must be powered before the starting motor is operated or damage can occur.

4. Start the engine in the normal operating procedure. Refer to this Operation and Maintenance Manual, "Starting the Engine".
5. Immediately after the engine is started, disconnect the jump-start cables in reverse order.

After jump starting, the alternator may not be able to recharge fully batteries that are severely discharged. The batteries must be replaced or charged to the proper voltage with a battery charger after the engine is stopped. Many batteries which are considered unusable are still rechargeable. Refer to Operation and Maintenance Manual, "Battery - Replace" and Testing and Adjusting Manual, "Battery - Test".

i06791278

After Starting Engine

Note: In temperatures from 0°C to 60°C (32°F to 140°F), the warm-up time is approximately 3 minutes. In temperatures below 0°C (32°F), extra warm-up time may be required.

When the engine idles during warm-up, observe the following conditions:

- Check for any fluid or for any air leaks at idle rpm and at one-half full rpm (no load on the engine) before operating the engine under load. This action may not be possible in some applications.
- Operate the engine at low idle until all systems achieve operating temperatures. Check all gauges during the warm-up period.

Constant speed engines should be allowed to operate at low idle for 3 minutes before used at operational speed. If the low idle option is not available, then operate the engine at operational speed with no load for 2 minutes.

Note: Gauge readings should be observed and the data should be recorded frequently while the engine is operating. Comparing the data over time will help to determine normal readings for each gauge. Comparing data over time will also help detect abnormal operating developments. Significant changes in the readings should be investigated.

Engine Operation

i05182510

Engine Operation

Proper operation and maintenance are key factors in obtaining the maximum life and economy of the engine. If the directions in the Operation and Maintenance Manual are followed, costs can be minimized and engine service life can be maximized.

The time that is needed for the engine to reach normal operating temperature can be less than the time taken for a walk-around inspection of the engine.

The engine can be operated at the rated rpm after the engine is started and after the engine reaches operating temperature. The engine will reach normal operating temperature sooner during a low engine speed (rpm) and during a low-power demand. This procedure is more effective than idling the engine at no load. The engine should reach operating temperature in a few minutes.

Avoid excess idling. Excessive idling causes carbon buildup, engine slobber and soot loading of the Diesel Particulate Filter (DPF). This excess idling is harmful to the engine.

Gauge readings should be observed and the data should be recorded frequently while the engine is operating. Comparing the data over time will help to determine normal readings for each gauge. Comparing data over time will also help detect abnormal operating developments. Significant changes in the readings should be investigated.

Reduction of Particulate Emissions

The Diesel Particulate Filter (DPF) and the Aftertreatment Regeneration Device (ARD) work together in order to reduce particulate emissions. The DPF collects the soot and any ash that is produced by the combustion in the engine. During regeneration, the soot is converted into a gas which is released into the atmosphere. The Ash remains in the DPF until the ash is cleaned out of the DPF.

The temperature of the DPF must be above a particular value in order for regeneration to occur. The exhaust gas provides heat for the regeneration process. There are two types of regeneration:

Passive Regeneration – The engine conditions are sufficient for regeneration. The rate of regeneration is much lower than active regeneration.

Active Regeneration – The engine duty cycle conditions are not sufficient for passive regeneration to occur.

The operator will receive information on the status of the ARD from dash lamps and the driver will be able to request a regeneration by using a switch. Refer to this Operation and Maintenance Manual, “Monitoring System” for more information.

Engine Operation and Active Regeneration

Active regeneration can be performed at any engine speed.

i05145051

Diesel Particulate Filter Regeneration

Regeneration

Regeneration is the removal of soot from the Diesel Particulate Filter (DPF). The Aftertreatment Regeneration Device (ARD) is used to regenerate the DPF. The DPF traps both soot and ash. The ash is removed through a manual cleaning process. Refer to Operation and Maintenance Manual, “Diesel Particulate Filter - Clean” for more information on the service of the DPF.

Types of Regeneration

Passive Regeneration – The engine conditions are sufficient for regeneration. The rate of regeneration is much lower than active regeneration.

Active Regeneration – The engine duty cycle conditions are not sufficient for passive regeneration to occur.

Regeneration Indicators

Five Indicators can be affected by the DPF regeneration.

Note: Amber or yellow Warning Indicator can be used as a diagnostic Indicator. For more information refer to this Operation and Maintenance Manual, “Diagnostic Lamp”.



Regeneration Active – The Indicator is illuminated during active regeneration. The Indicator will stay on until the aftertreatment has cooled.



DPF – This Indicator provides a general indication of the soot load. The Indicator is off when the soot load is normal.

Note: If the Indicator is illuminated, a regeneration will be required.



Regeneration Disable – This Indicator is illuminated whenever the disable switch is activated or the system has been disabled by the engine ECM.



Amber or yellow Warning – This Indicator, indicates that the soot load has increased. Regeneration is required. Also, the DPF Indicator will be illuminated. A flashing indicator will cause an engine derate.



Red Stop – This Indicator, indicates that the soot load is extremely high. The soot load is at level 3. The DPF Indicator will be illuminated and the amber warning indicator will be flashing. The engine will be shut down.

Regeneration Switch

The regeneration switch has three position force regeneration, automatic regeneration, and disable regeneration.

Note: Some OEMs may have other means of activating a forced regeneration such as touch screen interface.

Note: The MIDDLE position of the regeneration switch is the default position for automatic mode of regeneration.



Force Regeneration – Press in the top of the switch for 2 seconds in order to begin regeneration. An indicator light on the switch will become active showing that the regeneration is active. The regeneration active Indicator will become active showing that the regeneration is active.



Disable Regeneration – Press in the bottom of the switch for 2 seconds in order to disable regeneration. An indicator light on the switch will become active. The disable indicator will illuminate.

Note: To re-enable the regeneration, cycle the engine start switch key or press and hold down the force regeneration switch for 2 seconds.

Modes of Regeneration

- Automatic
- Forced Regeneration

Automatic regeneration is controlled by the engine ECM.

Automatic – Automatic regeneration allows for the DPF regeneration to start automatically with up to 80

percent load on the engine. In order for an automatic regeneration to occur, the following conditions must be met:

- Refer to OEM for the applications interlocks required to be engaged before regeneration can take place.

Forced regeneration – A forced regeneration is initiated by pressing the regeneration switch.

Soot Level Monitoring and Indicators

Note: In operation an Indicator can have two states, on solid and flashing. The sequence is to give a visual indication of the importance of the warning. Some application may also have an audible warning installed.

Ensure that the engine maintenance is carried out at the correct intervals. A lack of maintenance can result in illumination of the warning Indicators. For the correct intervals of maintenance, refer to the Operation and Maintenance Manual, “Maintenance Interval Schedule”.

Table 5

Indicator Operation					
Aftertreatment Indicator	Aftertreatment Indicator State	Warning Indicator	Warning Indicator State	Description	Action Required
All indicators are checked at key on. Any indicator illuminate after 2 seconds must be investigated. Any indicator that has not illuminated must be investigated.					
OFF	OFF	OFF	OFF	Normal operation	None
During passive regeneration NO indicators will be illuminated.					
Regeneration active	ON	OFF	OFF	The indicator shows that elevated emission temperatures are possible. The indicator will stay illuminated during regeneration.	None
Regeneration active	ON	OFF	OFF	Active regeneration occurring	
DPF	ON	OFF	OFF		
Level 1					
DPF	ON	OFF	OFF	Indication of soot loading	An active regeneration required
Level 2					
DPF	ON solid	Amber Indicator	Flashing	Soot loading has increased	Perform a forced regeneration, or a service regeneration will be required.
Level 3					
DPF	ON solid	Amber Indicator	Flashing	The flashing warning indicator will indicate that the engine has continued to be operated. The STOP warning indicator will indicate that the engine will be derated and will be shut down. After 30 seconds the engine will automatically shut down. The engine can be restarted but will only run for 30 seconds before shutting down again.	A forced regeneration is required. Hold the forced regeneration switch for 10 seconds before a regeneration begins. If Regeneration cannot occur, contact your Perkins dealer or distributor
		Stop indicator	On solid		

i07677865

Fuel Conservation Practices

The efficiency of the engine can affect the fuel economy. Perkins design and technology in manufacturing provides maximum fuel efficiency in all applications. Follow the recommended procedures to attain optimum performance for the life of the engine.

- Avoid spilling fuel.

Fuel expands when it is warmed up. The fuel may overflow from the fuel tank. Inspect fuel lines for leaks. Repair the fuel lines, as needed.

- Be aware of the properties of different fuels. Use only the recommended fuels. Refer to the Operations and Maintenance Manual, "Fuel Recommendations" for further information.

- Avoid unnecessary idling.

Shut off the engine rather than allowing the engine to idle for long periods of time.

- Observe the service indicator frequently. Keep the air cleaner elements clean.

Operation Section
Fuel Conservation Practices

- Ensure that the turbocharger is operating correctly. For more information refer to this Operation and Maintenance Manual, "Turbocharger - Inspect"
- Maintain a good electrical system.

One faulty battery cell will overwork the alternator. This fault will consume excess power and excess fuel.

- The belt should be in good condition. Refer to the Systems Operation, Testing and Adjusting, "V-Belt Test" for further information.
- Ensure that all the connections of the hoses are tight. The connections should not leak.
- Ensure that the driven equipment is in good working order.
- Cold engines consume excess fuel. Utilize heat from the jacket water system and the exhaust system, when possible. Keep cooling system components clean and keep cooling system components in good repair. Never operate the engine without water temperature regulators. All these items will help maintain operating temperatures.

Cold Weather Operation

i05302610

Cold Weather Operation

Perkins Diesel Engines can operate effectively in cold weather. During cold weather, the starting and the operation of the diesel engine is dependent on the following items:

- The type of fuel that is used
- The viscosity of the engine oil
- The operation of the glow plugs
- Optional Cold starting aid
- Battery condition

This section will cover the following information:

- Potential problems that are caused by cold-weather operation
- Suggest steps which can be taken in order to minimize starting problems and operating problems when the ambient air temperature is between 0° to -40 °C (32° to 40 °F).

The operation and maintenance of an engine in freezing temperatures is complex . This complexity is because of the following conditions:

- Weather conditions
- Engine applications

Recommendations from your Perkins dealer or your Perkins distributor are based on past proven practices. The information that is contained in this section provides guidelines for cold-weather operation.

Hints for Cold Weather Operation

- If the engine will start, operate the engine until a minimum operating temperature of 80° C (176° F) is achieved. Achieving operating temperature will help prevent the intake valves and exhaust valves from sticking.
- The cooling system and the lubrication system for the engine do not lose heat immediately upon shutdown. This means that an engine can be shut down for a period and the engine can still have the ability to start readily.

- Install the correct specification of engine lubricant before the beginning of cold weather. Refer to this Operation and Maintenance Manual, "Fluid Recommendations" for the recommended viscosity of oil.
- Check all rubber parts (hoses, fan drive belts,) weekly.
- Check all electrical wiring and connections for any fraying or damaged insulation.
- Keep all batteries fully charged and warm by ensuring that the engine is allowed to operate at normal operating temperature.
- Fill the fuel tank at the end of each shift.
- Check the air cleaners and the air intake daily. Check the air intake more often when you operate in snow.
- Ensure that the glow plugs are in working order. Refer to Troubleshooting, "Glow Plug Starting Aid-Test".

WARNING

Personal injury or property damage can result from alcohol or starting fluids.

Alcohol or starting fluids are highly flammable and toxic and if improperly stored could result in injury or property damage.

WARNING

Do not use aerosol types of starting aids such as ether. Such use could result in an explosion and personal injury.

- For jump starting with cables in cold weather, refer to the Operation and Maintenance Manual, "Starting with Jump Start Cables." for instructions.

Viscosity of the Engine Lubrication Oil

Correct engine oil viscosity is essential. Oil viscosity affects lubrication properties and wear protection that the oil provides for the engine. Refer to this Operation and Maintenance Manual, "Fluid Recommendations" for the recommended viscosity of oil.

Recommendations for the Coolant

Provide cooling system protection for the lowest expected outside temperature. Refer to this Operation and Maintenance Manual, "Fluid Recommendations" for the recommended coolant mixture.

In cold weather, check the coolant often for the correct glycol concentration in order to ensure adequate freeze protection.

Engine Block Heaters

Engine block heaters (if equipped) heat the engine jacket water that surrounds the combustion chambers. This heat provides the following functions:

- Startability is improved.
- Warm up time is reduced.

An electric block heater can be activated once the engine is stopped. A block heater can be 110 V dc or 240 V dc. The output can be 750/1000W. Consult your Perkins dealer or your Perkins distributor for more information.

Idling the Engine

When idling after the engine is started in cold weather, increase the engine rpm from 1000 to 1200 rpm. This idling will warm up the engine more quickly. Maintaining an elevated low idle speed for extended periods will be easier with the installation of a hand throttle. The engine should not be "raced" in order to speed up the warm-up process.

While the engine is idling, the application of a light load (parasitic load) will assist in achieving the minimum operating temperature. The minimum operating temperature is 80° C (176° F).

Recommendations for Coolant Warm Up

Warm up an engine that has cooled below normal operating temperatures due to inactivity. This warm-up should be performed before the engine is returned to full operation. During operation in very cold temperature conditions, damage to engine valve mechanisms can result from engine operation for short intervals. This damage can happen if the engine is started and the engine is stopped many times without being operated in order to warm up completely.

When the engine is operated below normal operating temperatures, fuel and oil are not completely burned in the combustion chamber. This fuel and oil causes soft carbon deposits to form on the valve stems. Generally, the deposits do not cause problems and the deposits are burned off during operation at normal engine operating temperatures.

When starting and stopping an engine many times without being operated in order to warm up completely, the carbon deposits become thicker. This starting and stopping can cause the following problems:

- Free operation of the valves is prevented.

- Valves become stuck.
- Pushrods may become bent.
- Other damage to valve train components can result.

For this reason, when the engine is started, the engine must be operated until the coolant temperature is 80° C (176° F) minimum. Carbon deposits on the valve stems will be kept at a minimum and the free operation of the valves and the valve components will be maintained.

The engine must be thoroughly warmed in order to keep other engine parts in better condition. The service life of the engine will be generally extended. Lubrication will be improved. There will be less acid and less sludge in the oil. This condition will provide longer service life for the engine bearings, the piston rings, and other parts. However, limit unnecessary idle time to 10 minutes in order to reduce wear and unnecessary fuel consumption.

The Water Temperature Regulator and Insulated Heater Lines

The engine is equipped with a water temperature regulator. When the engine coolant is below the correct operating temperature, jacket water circulates through the engine cylinder block and into the engine cylinder head. The coolant then returns to the cylinder block via an internal passage that bypasses the valve of the coolant temperature regulator. This return ensures that coolant flows around the engine under cold operating conditions. The water temperature regulator begins to open when the engine jacket water has reached the correct minimum operating temperature. As the jacket water coolant temperature rises above the minimum operating temperature, the water temperature regulator opens further allowing more coolant through the radiator to dissipate excess heat.

The progressive opening of the water temperature regulator operates the progressive closing of the bypass passage between the cylinder block and head. This action ensures maximum coolant flow to the radiator in order to achieve maximum heat dissipation.

Note: Do not restrict the air flow. Restriction of the air flow can damage the fuel system. Perkins discourages the use of all air flow restriction devices such as radiator shutters. Restriction of the air flow can result in the following: high exhaust temperatures, power loss, excessive fan usage and reduction in fuel economy.

A cab heater is beneficial in very cold weather. The feed from the engine and the return lines from the cab should be insulated in order to reduce heat loss to the outside air.

Recommendation for Crankcase Breather Protection

Crankcase ventilation gases contain a large quantity of water vapor. This water vapor can freeze in cold ambient conditions and can plug or damage the crankcase ventilation system. If the engine is operated in temperatures below -25°C (-13°F), measures must be taken to prevent freezing and plugging of the breather system. An open breather system will operate more effectively in temperatures below -25°C (-13°F). In extreme weather conditions insulating the breather hose will help to protect the system.

Consult with your Perkins dealer or your Perkins distributor for the recommended breather components for operation from -25° to -40°C (-13° to -72°F).

i05927268

Fuel and the Effect from Cold Weather

Note: Only use grades of fuel that are recommended by Perkins. Refer to this Operation and Maintenance Manual, "Fluid Recommendations".

Properties of the diesel fuel can have a significant effect on the engine cold start capability. Critical to the low temperature properties of diesel fuel is the acceptability for the minimum ambient temperature the engine is expected to see in operation. Following properties are used to define fuels low temperature capability:

- Cloud point
- Pour point
- Cold Filter Plugging Point (CFPP)

The cloud point of the fuel is the temperature at which waxes naturally found in diesel fuel begins to form crystals. The cloud point of the fuel must be below lowest ambient temperature to prevent filters from plugging.

CFPP is a temperature at which a particular fuel will pass through a standardized filtration device. The CFPP gives an estimate of the lower operability temperature of fuel.

Pour point is the last temperature before the fuel flow stops and waxing of the fuel will start.

Be aware of these properties when diesel fuel is purchased. Consider the average ambient air temperature for the engines application. Engines that are fueled in one climate may not operate well if the engines are shipped to colder climate. Problems can result due to changes in temperature.

Before troubleshooting for low power or for poor performance in the winter, check the fuel for waxing.

The following components can provide a means of minimizing fuel waxing problems in cold weather:

- Fuel heaters, which may be an OEM option
- Fuel line insulation, which may be an OEM option

Winter and arctic grades of diesel fuel are available in the countries and territories with severe winters. For more information refer to the Operation and Maintenance Manual, "Cold Weather Operation"

Another important fuel property which can affect cold start and operation of diesel engine is cetane number. For more information refer to the Operation and Maintenance Manual, "Fluid Recommendations".

i05200880

Fuel Related Components in Cold Weather

Fuel Tanks

Condensation can form in partially filled fuel tanks. Top off the fuel tanks after you operate the engine.

Fuel tanks should contain some provision for draining water and sediment from the bottom of the tanks. Some fuel tanks use supply pipes that allow water and sediment to settle below the end of the fuel supply pipe.

Some fuel tanks use supply lines that take fuel directly from the bottom of the tank. If the engine is equipped with this system, regular maintenance of the fuel system filter is important.

Drain the water and sediment from any fuel storage tank at the following intervals: weekly, oil changes and refueling of the fuel tank. This procedure will help prevent water and/or sediment from being pumped from the fuel storage tank and into the engine fuel tank.

Fuel Filters

The engine must have an in-line fuel filter installed between the fuel tank and the electric operated fuel lift pump. After you change the fuel filter, always prime the fuel system in order to remove air bubbles from the fuel system. Refer to the Operation and Maintenance Manual in the Maintenance Section for more information on priming the fuel system.

Fuel Heaters

Fuel heaters help to prevent fuel filters from plugging in cold weather due to waxing.

Operation Section
Fuel Related Components in Cold Weather

For further information on fuel heaters, consult your Perkins dealer or distributor.

Engine Stopping

i03756631

i06832774

Stopping the Engine

NOTICE

Stopping the engine immediately after it has been working under load, can result in overheating and accelerated wear of the engine components.

Avoid accelerating the engine prior to shutting it down.

Avoiding hot engine shutdowns will maximize turbo-charger shaft and bearing life.

Note: Individual applications will have different control systems. Ensure that the shutoff procedures are understood. Use the following general guidelines to stop the engine.

1. Remove the load from the engine. Reduce the engine speed (rpm) to low idle. Allow the engine to idle for 5 minutes to cool the engine.
 2. Stop the engine after the cool down period according to the shutoff system on the engine. Turn the ignition key switch to the OFF position. If necessary, refer to the instructions that are provided by the OEM.
-

NOTICE

Before any service or repairs are performed, ensure that the power supply to the engine is disconnected.

i07764840

Emergency Stopping

NOTICE

Emergency shutoff controls are for EMERGENCY use ONLY. DO NOT use emergency shutoff devices or controls for normal stopping procedure.

The Original Equipment Manufacturer (OEM) may have equipped the application with an emergency stop button. For more information about the emergency stop button, refer to the OEM information.

Ensure that any components for the external system that support the engine operation are secured after the engine is stopped.

After Stopping Engine

Note: Before you check the engine oil, do not operate the engine for at least 10 minutes in order to allow the engine oil to return to the oil pan.

- Check the crankcase oil level. Maintain the oil level between the “MIN” mark and the “MAX” mark on the engine oil level gauge.
 - If necessary, perform minor adjustments. Repair any leaks and tighten any loose bolts.
 - If the engine is equipped with a service hour meter, note the reading. Perform the maintenance that is in the Operation and Maintenance Manual, “Maintenance Interval Schedule”.
 - Fill the fuel tank in order to help prevent accumulation of moisture in the fuel. Do not overfill the fuel tank.
-

NOTICE

Only use antifreeze/coolant mixtures recommended in the Refill Capacities and Recommendations topic that is in this Operation and Maintenance Manual. Failure to do so can cause engine damage.

- Allow the engine to cool. Check the coolant level.
- If freezing temperatures are expected, check the coolant for correct antifreeze protection. The cooling system must be protected against freezing to the lowest expected outside temperature. Add the correct coolant/water mixture, if necessary.
- Perform all required periodic maintenance on all driven equipment. This maintenance is outlined in the instructions from the OEM.

Maintenance Section

Refill Capacities

i05145430

Refill Capacities

Lubrication System

The refill capacities for the engine crankcase reflect the approximate capacity of the crankcase or sump plus standard oil filters. Auxiliary oil filter systems will require additional oil. Refer to the OEM specifications for the capacity of the auxiliary oil filter. Refer to the Operation and Maintenance Manual, "Maintenance Section" for more information on Lubricant Specifications.

403F-15T Engine

Table 6

403F-15T Engine Refill Capacities		
Compartment or System	Minimum	Maximum
Crankcase Oil Sump ⁽¹⁾	4.5 L (4.8 qt)	6 L (6.3 qt)
Total Lubrication System ⁽²⁾		

(1) These values are the approximate capacities for the crankcase oil sump which includes the standard factory installed oil filters. Engines with auxiliary oil filters will require additional oil. Refer to the OEM specifications for the capacity of the auxiliary oil filter.

(2) The Total Lubrication System includes the capacity for the Crankcase Oil Sump plus the capacity of factory installed oil filters and other filters added to the lubrication system. Enter the value for the capacity of the Total Lubrication System in this row.

404F-22 and 404F-22T Engines

Table 7

404F-22 and 404F-22T Engines Refill Capacities		
Compartment or System	Minimum	Maximum
Crankcase Oil Sump ⁽¹⁾	8.9 L (9.4 qt)	10.6 L (11.2 qt)
Total Lubrication System ⁽²⁾		

(continued)

(Table 7, contd)

- (1) More than one style of sump may be used on these engines. Use these values to estimate the refill capacity. Use the engine oil level gauge to fill the engine to the correct oil level. Record the result in this table. These values are the approximate capacities for the Crankcase Oil Sump which includes the standard factory installed oil filters. Engines with auxiliary oil filters will require additional oil. Refer to the OEM specifications for the capacity of the auxiliary oil filter.
- (2) The Total Lubrication System includes the capacity for the Crankcase Oil Sump plus the capacity of factory installed oil filters and other filters added to the lubrication system. Enter the value for the capacity of the Total Lubrication System in this row.

Cooling System

To maintain the cooling system, the Total Cooling System capacity must be known. The approximate capacity is for the engine cooling system. External System capacities will vary among applications. Refer to the OEM specifications for the External System capacity. This capacity information will be needed in order to determine the amount of coolant that is required for the Total Cooling System.

403F-15T Engine

Table 8

403F-15T Engine Refill Capacities		
Compartment or System	Liters	Quarts
Engine Only	2.6	2.7
External System Per OEM ⁽¹⁾		
Total Cooling System ⁽²⁾		

(1) The External System includes a radiator or an expansion tank with the following components: heat exchanger and piping. Refer to the OEM specifications. Enter the value for the capacity of the External System in this row.

(2) The Total Cooling System capacity includes the capacity of the Engine plus the External System. Enter the value for the capacity of the Total Cooling System in this row.

404F-22 Engine

Table 9

404F-22 Engine Refill Capacities		
Compartment or System	Liters	Quarts
Engine Only	3.61	3.8
External System Per OEM ⁽¹⁾		
Total Cooling System ⁽²⁾		

(1) The External System includes a radiator or an expansion tank with the following components: heat exchanger and piping. Refer to the OEM specifications. Enter the value for the capacity of the External System in this row.

(2) The Total Cooling System capacity includes the capacity for the Engine plus the External System. Enter the value for the capacity of the Total Cooling System in this row.

404F-22T Engine

Table 10

404F-22T Engine Refill Capacities		
Compartment or System	Liters	Quarts
Engine Only	3.91	4.13
External System Per OEM ⁽¹⁾		
Total Cooling System ⁽²⁾		

(1) The External System includes a radiator or an expansion tank with the following components: heat exchanger and piping. Refer to the OEM specifications. Enter the value for the capacity of the External System in this row.

(2) The Total Cooling System capacity includes the capacity for the Engine plus the External System. Enter the value for the capacity of the Total Cooling System in this row.

i04057529

Fluid Recommendations

- **Glossary**
- ISO International Standards Organization
- ASTM American Society for Testing and Materials
- HFRR High Frequency Reciprocating Rig for Lubricity testing of diesel fuels
- FAME Fatty Acid Methyl Esters
- CFR Co-ordinating Fuel Research
- ULSD Ultra Low Sulfur Diesel
- RME Rape Methyl Ester
- SME Soy Methyl Ester
- EPA Environmental Protection Agency of the United States
- PPM Parts Per Million
- DPF Diesel Particulate Filter

General Information

NOTICE

Every attempt is made to provide accurate, up-to-date information. By use of this document you agree that Perkins Engines Company Limited is not responsible for errors or omissions.

NOTICE

These recommendations are subject to change without notice. Contact your local Perkins distributor for the most up-to-date recommendations.

The fuel information within this OMM is for use with the following engine models: 403F-15T, 404F-22, 404F-22T, and 404F-22TA

Diesel Fuel Requirements

Perkins is not in a position to continuously evaluate and monitor all worldwide distillate diesel fuel specifications that are published by governments and technological societies.

The Perkins table for Specification for Distillate Diesel Fuel provides a known reliable baseline in order to judge the expected performance of distillate diesel fuels that are derived from conventional sources.

Satisfactory engine performance is dependent on the use of a good quality fuel. The use of a good quality fuel will give the following results: long engine life and acceptable exhaust emissions levels. The fuel must meet the minimum requirements that are stated in the table 11 .

NOTICE

The footnotes are of the key part Perkins Specification for Distillate Diesel Fuel Table. Read ALL of the footnotes.

Maintenance Section
Fluid Recommendations

Table 11

Perkins Specification for Distillate Diesel Fuel ⁽¹⁾				
Property	UNITS	Requirements	"ASTM" Test	"ISO" Test
Aromatics	%Volume	35% maximum	D1319	"ISO"3837
Ash	%Weight	0.01% maximum	D482	"ISO"6245
Carbon Residue on 10% Bottoms	%Weight	0.35% maximum	D524	"ISO"4262
Cetane Number ⁽²⁾	-	40 minimum	D613/D6890	"ISO"5165
Cloud Point	°C	The cloud point must not exceed the lowest expected ambient temperature.	D2500	"ISO"3015
Copper Strip Corrosion	-	No. 3 maximum	D130	"ISO"2160
Density at 15 °C (59 °F) ⁽³⁾	Kg / M ³	801 minimum and 876 maximum	No equivalent test	"ISO 3675" "ISO 12185"
Distillation	°C	10% at 282 °C (539.6 °F) maximum 90% at 360 °C (680 °F) maximum	D86	"ISO"3405
Flash Point	°C	legal limit	D93	"ISO"2719
Thermal Stability	-	Minimum of 80% reflectance after aging for 180 minutes at 150 °C (302 °F)	D6468	No equivalent test
Pour Point	°C	6 °C (42.8 °F) minimum below ambient temperature	D97	"ISO"3016
Sulfur ⁽¹⁾	%mass	0.0015	D5453/D26222	"ISO 20846" "ISO 20884"
Kinematic Viscosity ⁽⁴⁾	"MM" ² /S (cSt)"	The viscosity of the fuel that is delivered to the fuel injection pump. "1.4 minimum/ 4.5 maximum"	D445	"ISO"3405
Water and sediment	% weight	0.1% maximum	D1796	"ISO"3734
Water	% weight	0.1% maximum	D1744	No equivalent test
Sediment	% weight	0.05% maximum	D473	"ISO"3735
Gums and Resins ⁽⁵⁾	mg/100mL	10 mg per 100 mL maximum	D381	"ISO"6246
Lubricity corrected wear scar diameter at 60 °C (140 °F). ⁽⁶⁾	mm	0.52 maximum	D6079	"ISO"12156-1

(1) This specification includes the requirements for Ultra Low Sulfur Diesel (ULSD). ULSD fuel will have ≤ 15 ppm (0.0015%) sulfur. Refer to "ASTM D5453", "ASTM D2622", or "ISO 20846, ISO 20884" test methods.

(2) A fuel with a higher cetane number is recommended in order to operate at a higher altitude or in cold weather.

(3) "Via standards tables, the equivalent API gravity for the minimum density of 801 kg / m³ (kilograms per cubic meter) is 45 and for the maximum density of 876 kg / m³ is 30".

(4) The values of the fuel viscosity are the values as the fuel is delivered to the fuel injection pumps. Fuel should also meet the minimum viscosity requirement and the fuel should meet the maximum viscosity requirements at 40 °C (104 °F) of either the "ASTM D445" test method or the "ISO 3104" test method. If a fuel with a low viscosity is used, cooling of the fuel may be required to maintain "1.4 cSt" or greater viscosity at the fuel injection pump. Fuels with a high viscosity might require fuel heaters in order to lower the viscosity to "1.4 cSt" at the fuel injection pump.

(5) Follow the test conditions and procedures for gasoline (motor).

(6) The lubricity of a fuel is a concern with ultra low sulfur fuel. To determine the lubricity of the fuel, use the "ISO 12156-1 or ASTM D6079 High Frequency Reciprocating Rig (HFRR)" test. If the lubricity of a fuel does not meet the minimum requirements, consult your fuel supplier. Do not treat the fuel without consulting the fuel supplier. Some additives are not compatible. These additives can cause problems in the fuel system.

Engines that are manufactured by Perkins are certified with the fuel that is prescribed by the United States Environmental Protection Agency. Engines that are manufactured by Perkins are certified with the fuel that is prescribed by the European Certification. Perkins does not certify diesel engines on any other fuel.

Note: The owner and the operator of the engine has the responsibility of using the fuel that is prescribed by the EPA and other appropriate regulatory agencies.

NOTICE

Operating with fuels that do not meet the Perkins recommendations can cause the following effects: Starting difficulty, poor combustion, deposits in the fuel injectors, reduced service life of the fuel system, deposits in the combustion chamber and reduced service life of the engine.

The Perkins 400F diesel engines must be operated using Ultra Low Sulfur Diesel. The sulphur content of this fuel must be lower than 15 PPM. This fuel complies with the emissions regulations that are prescribed by the Environmental Protection Agency of the United States

The fuels that are listed in the table 12 are acceptable to use on all 400F engines.

Table 12

Acceptable Fuel Specification for the 400F Engines ⁽¹⁾	
Fuel Specification	Comments
EN590	European Automotive Diesel Fuel (DERV)
"ASDM D975 GRADE 1D S15"	"North American Light Distillate Diesel fuel with less than 15 PPM sulfur level"
"ASTM D975 GRADE 2D S15"	"North American Middle Distillate general purpose Diesel fuel with less than 15 PPM sulfur level"
"JIS K2204"	"Japanese Diesel Fuel" Must meet the requirements that are stated in the section "Lubricity".
"BS 2869 or equivalent "	"EU Off Road Diesel fuel. Acceptable from 2011 MUST have less than 10 PPM sulfur level"

⁽¹⁾ All the fuels must comply with the specification in the table for the Perkins Specification Distillate Diesel Fuel.

Diesel Fuel Characteristics

Cetane Number

Fuel that has a high cetane number will give a shorter ignition delay. A high cetane number will produce a better ignition quality. Cetane numbers are derived for fuels against proportions of cetane and heptamethylnonane in the standard CFR engine. Refer to "ISO 5165" for the test method.

Cetane numbers in excess of 45 are normally expected from current diesel fuel. However, a cetane number of 40 may be experienced in some territories. The United States of America is one of the territories that can have a low cetane value. A minimum cetane value of 40 is required during average starting conditions. A fuel with higher cetane number is recommended for operations at high altitudes or in cold-weather operations.

Fuel with a low cetane number can be the root cause of problems during a cold start.

Viscosity

Viscosity is the property of a liquid of offering resistance to shear or flow. Viscosity decreases with increasing temperature. This decrease in viscosity follows a logarithmic relationship for normal fossil fuel. The common reference is to kinematic viscosity. Kinematic viscosity is the quotient of the dynamic viscosity that is divided by the density. The determination of kinematic viscosity is normally by readings from gravity flow viscometers at standard temperatures. Refer to "ISO 3104" for the test method.

The viscosity of the fuel is significant because fuel serves as a lubricant for the fuel system components. Fuel must have sufficient viscosity in order to lubricate the fuel system in both extremely cold temperatures and extremely hot temperatures. If the kinematic viscosity of the fuel is lower than "1.4 cSt" at the fuel injection pump, damage to the fuel injection pump can occur. This damage can be excessive scuffing and seizure. Low viscosity may lead to difficult hot restarting, stalling, and loss of performance. High viscosity may result in seizure of the pump.

Perkins recommends kinematic viscosities of 1.4 and 4.5 mm²/sec that is delivered to the fuel injection pump. If a fuel with a low viscosity is used, cooling of the fuel may be required to maintain 1.4 cSt or greater viscosity at the fuel injection pump. Fuels with a high viscosity might require fuel heaters in order to lower the viscosity to 4.5 cSt at the fuel injection pump.

Density

Density is the mass of the fuel per unit volume at a specific temperature. This parameter has a direct influence on engine performance and a direct influence on emissions. This influence determines from a heat output given injected volume of fuel. This parameter is quoted in the following kg/m at 15 °C (59 °F).

Perkins recommends a value of density of 841 kg/m in order to obtain the correct power output. Lighter fuels are acceptable but these fuels will not produce the rated power.

Sulfur

The level of sulfur is governed by emissions legislations. Regional regulation, national regulations, or international regulations can require a fuel with a specific sulfur limit. The sulfur content of the fuel and the fuel quality must comply with all existing local regulations for emissions.

By using the test methods "ASTM D5453, ASTM D2622, or ISO 20846 ISO 20884", the content of sulfur in ultra low sulfur (ULSD) fuel must be below 15 PPM 0.0015%. The lubricity of these fuels must not exceed wear scar diameter of 0.52 mm (0.0205 inch). The fuel lubricity test must be performed on an HFRR, operated at 60 °C (140 °F). Refer to "ISO 12156-1".

Lubricity

Lubricity is the capability of the fuel to prevent pump wear. The fluids lubricity describes the ability of the fluid to reduce the friction between surfaces that are under load. This ability reduces the damage that is caused by friction. Fuel injection systems rely on the lubricating properties of the fuel. Until fuel sulfur limits were mandated, the fuels lubricity was generally believed to be a function of fuel viscosity.

The lubricity has particular significance to the current low viscosity fuel, low sulfur fuel, and low aromatic fossil fuel. These fuels are made in order to meet stringent exhaust emissions. A test method for measuring the lubricity of diesel fuels has been developed and the test is based on the HFRR method that is operated at 60°C (140°F). Refer to "ISO 12156 part 1 and CEC document F06-A-96" for the test method.

Lubricity wear scar diameter of 0.52 mm (0.0205 inch) MUST NOT be exceeded. The fuel lubricity test must be performed on an HFRR, operated at 60 °C (140 °F). Refer to "ISO 12156-1".

Distillation

Distillation is an indication of the mixture of different hydrocarbons in the fuel. A high ratio of light weight hydrocarbons can affect the characteristics of combustion.

Recommendation for Biodiesel

Biodiesel is a fuel that can be defined as mono-alkyl esters of fatty acids. Biodiesel is a fuel that can be made from various feedstock. The most commonly available biodiesel in Europe is Rape Methyl Ester (REM). This biodiesel is derived from rapeseed oil. Soy Methyl Ester (SME) is the most common biodiesel in the United States. This biodiesel is derived from soybean oil. Soybean oil or rapeseed oil are the primary feedstocks. These fuels are together known as Fatty Acid Methyl Esters (FAME).

Raw pressed vegetable oils are NOT acceptable for use as a fuel in any concentration in compression engines. Without esterification, these oils solidify in the crankcase and the fuel tank. These fuels may not be compatible with many of the elastomers that are used in engines that are manufactured today. In original forms, these oils are not suitable for use as a fuel in compression engines. Alternate base stocks for biodiesel may include animal tallow, waste cooking oils, or various other feedstocks. In order to use any of the products that are listed as fuel, the oil must be esterified.

Fuel made of 100 percent FAME is generally referred to as B100 biodiesel or neat biodiesel.

Biodiesel can be blended with distillate diesel fuel. The blends can be used as fuel. The most commonly available biodiesel blends are B7, which is 7 percent biodiesel and 95 percent distillate diesel fuel.

Note: The percentages given are volume-based.

The U.S. distillate diesel fuel specification "ASTM D975-09a" includes up to B5 (5 percent) biodiesel.

European distillate diesel fuel specification EN590 includes up to B7 (7 percent) biodiesel. Any diesel fuel in Europe may contain up to B5 or in some regions up to B7 biodiesel fuel.

Note: Engines that are manufactured by Perkins are certified by use of the prescribed Environmental Protection Agency (EPA) and European Certification fuels. Perkins does not certify engines on any other fuel. The user of the engine has the responsibility of using the correct fuel that is recommended by the manufacturer and allowed by the EPA and other appropriate regulatory agencies.

Fuel for Cold Weather Operation

The European standard "EN590" contains climate dependant requirements and a range of options. The options can be applied differently in each country. There are five classes that are given to arctic climates and severe winter climates. 0, 1, 2, 3 and 4.

Fuel that complies with "EN590" CLASS 4 can be used at temperatures as low as -44°C (-47.2°F). Refer to "EN590" for a detailed discretion of the physical properties of the fuel.

The diesel fuel "ASTM D975 1-D" used in the United States of America may be used in very cold temperatures that are below -18°C (-0.4°F).

Aftermarket Fuel Additives

Supplemental diesel fuel additives are not generally recommended. This recommendation is due to potential damage to the fuel system or the engine. Your fuel supplier or the fuel manufacturer will add the appropriate supplemental diesel fuel additives.

Perkins recognizes the fact that additives may be required in some special circumstances. Contact your fuel supplier for those circumstances when fuel additives are required. Your fuel supplier can recommend the appropriate fuel additive and the correct level of treatment.

Note: For the best results, your fuel supplier should treat the fuel when additives are required. The treated fuel must meet the requirements that are stated in table 11 .

Perkins Diesel Fuel System Cleaner

Perkins T400012 Fuel Cleaner is the only fuel cleaner that is recommended by Perkins.

If biodiesel or biodiesel blends of fuel are to be used, Perkins require the use of Perkins fuel cleaner. The use of the fuel is in order to remove deposits within the fuel system that is created with the use of biodiesel. For more information on the use of biodiesel and biodiesel blends refer to "Recommendation for Biodiesel".

Perkins fuel cleaner will remove deposits that can form in the fuel system with the use of biodiesel and biodiesel blends. These deposits can create a loss of power and engine performance.

Once the fuel cleaner has been added to the fuel, the deposits within the fuel system are removed after 30 hours of engine operation. For maximum results, continue to use the fuel cleaner for up to 80 hours. Perkins fuel cleaner can be used on an on-going basis with no adverse impact on engine or fuel system durability.

Details instruction on the rate of which the fuel cleaner must be use are on the container.

Note: Perkins fuel cleaner is compatible with existing and U.S. EPA Tier 4 nonroad certified diesel engine emission control catalysts and particulate filters. Perkins fuel system cleaner contains less than 15 ppm of sulfur and is acceptable for use with ULSD fuel.

i04129134

Fluid Recommendations

General Lubricant Information

Because of government regulations regarding the certification of exhaust emissions from the engine, the lubricant recommendations must be followed.

- API_____American Petroleum Institute
- SAE_____Society Of Automotive Engineers Inc.

- ACEA _____ Association des Constructeurs European Automobiles.
- ECF-3 _____ Engine Crankcase Fluid

Licensing

The Engine Oil Licensing and Certification System by the American Petroleum Institute (API) and the Association des Constructeurs European Automobiles (ACEA) is recognized by Perkins. For detailed information about this system, see the latest edition of the "API publication No. 1509". Engine oils that bear the API symbol are authorized by API.

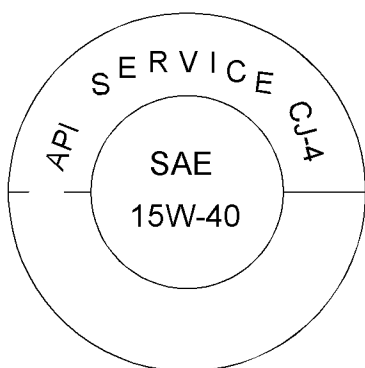

Illustration 39

g01987816

Typical API symbol

Terminology

Certain abbreviations follow the nomenclature of "SAE J754". Some classifications follow "SAE J183" abbreviations, and some classifications follow the "EMA Recommended Guideline on Diesel Engine Oil". In addition to Perkins definitions, there are other definitions that will be of assistance in purchasing lubricants. Recommended oil viscosities can be found in this publication, "Fluid Recommendations/ Engine Oil" topic (Maintenance Section).

Engine Oil

Commercial Oils

NOTICE

Perkins require the use of the following specification of engine oil. Failure to use the appropriate specification of engine oil will reduce the life of your engine. Failure to use the appropriate specification of engine oil will also reduce the life of your aftertreatment system.

Table 13

Classifications for the 400F Industrial Engines
Oil Specification
CJ-4 ACEA E9 ECF-3

API CJ-4 and ACEA E9 oil categories have the following chemical limits:

- 0.1 percent maximum sulfated ash
- 0.12 percent maximum phosphorous
- 0.4 percent maximum sulfur

The chemical limits were developed in order to maintain the expected life of the engine aftertreatment system. The performance of the engine aftertreatment system can be adversely affected if oil that is not specified in table 13 is used.

The life of your Aftertreatment system is defined by the accumulation of ash on the surface of the filter. Ash is the inert part of the particulate matter. The system is designed in order to collect this particulate matter. There is a very small percentage of particulate matter that is left behind as the soot is burnt. This matter will eventually block the filter, causing loss of performance and increased fuel consumption. Most of the ash comes from the engine oil which is gradually consumed during normal operation. This ash passes through the exhaust. To meet the designed life of the product, the use of the appropriate engine oil is essential. The oil specification that is listed in table 13 has low ash content.

Maintenance intervals for engines that use biodiesel – The oil change interval can be adversely affected by the use of biodiesel. Use oil analysis in order to monitor the condition of the engine oil. Use oil analysis also in order to determine the oil change interval that is optimum.

Note: These engine oils are not approved by Perkins and these engine oils must not be used: CC, CD, CD-2, CF-4, CG-4, CH-4 and CI-4.

Lubricant Viscosity Recommendations for Direct Injection (DI) Diesel Engines

The correct SAE viscosity grade of oil is determined by the minimum ambient temperature during cold engine start-up, and the maximum ambient temperature during engine operation.

Refer to illustration40 (minimum temperature) in order to determine the required oil viscosity for starting a cold engine.

Refer to illustration 40 (maximum temperature) in order to select the oil viscosity for engine operation at the highest ambient temperature that is anticipated.

Generally, use the highest oil viscosity that is available to meet the requirement for the temperature at start-up.

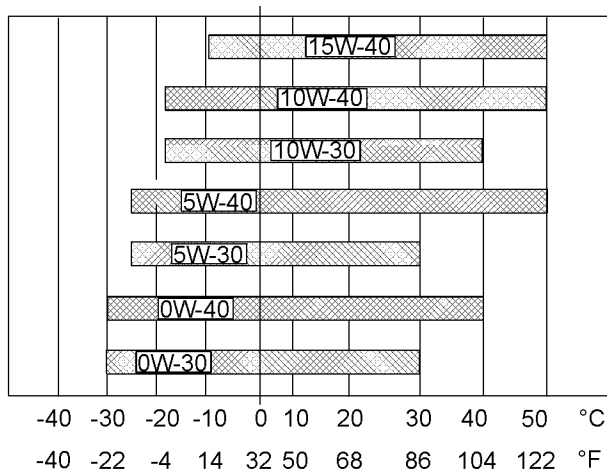

Illustration 40

g02932046

Lubricant Viscosities

Supplemental heat is recommended for cold soaked starts below the minimum ambient temperature. Supplemental heat may be required for cold soaked starts that are above the minimum temperature that is stated, depending on the parasitic load and other factors. Cold soaked starts occur when the engine has not been operated for a period of time. This interval will allow the oil to become more viscous due to cooler ambient temperatures.

Aftermarket Oil Additives

Perkins does not recommend the use of aftermarket additives in oil. It is not necessary to use aftermarket additives in order to achieve the engines maximum service life or rated performance. Fully formulated, finished oils consist of base oils and of commercial additive packages. These additive packages are blended into the base oils at precise percentages in order to help provide finished oils with performance characteristics that meet industry standards.

There are no industry standard tests that evaluate the performance or the compatibility of aftermarket additives in finished oil. Aftermarket additives may not be compatible with the finished oils additive package, which could lower the performance of the finished oil. The aftermarket additive could fail to mix with the finished oil. This failure could produce sludge in the crankcase. Perkins discourages the use of aftermarket additives in finished oils.

To achieve the best performance from a Perkins engine, conform to the following guidelines:

- See the appropriate "Lubricant Viscosities". Refer to the illustration 40 in order to find the correct oil viscosity grade for your engine.
- At the specified interval, service the engine. Use new oil and install a new oil filter.
- Perform maintenance at the intervals that are specified in the Operation and Maintenance Manual, "Maintenance Interval Schedule".

Oil analysis

Some engines may be equipped with an oil sampling valve. If oil analysis is required, the oil sampling valve is used to obtain samples of the engine oil. The oil analysis will complement the preventive maintenance program.

The oil analysis is a diagnostic tool that is used to determine oil performance and component wear rates. Contamination can be identified and measured by using oil analysis. The oil analysis includes the following tests:

- The Wear Rate Analysis monitors the wear of the engines metals. The amount of wear metal and type of wear metal that is in the oil is analyzed. The increase in the rate of engine wear metal in the oil is as important as the quantity of engine wear metal in the oil.
- Tests are conducted in order to detect contamination of the oil by water, glycol, or fuel.
- The Oil Condition Analysis determines the loss of the oils lubricating properties. An infrared analysis is used to compare the properties of new oil to the properties of the used oil sample. This analysis allows technicians to determine the amount of deterioration of the oil during use. This analysis also allows technicians to verify the performance of the oil according to the specification during the entire oil change interval.

i05191400

Fluid Recommendations

General Coolant Information

NOTICE

Never add coolant to an overheated engine. Engine damage could result. Allow the engine to cool first.

NOTICE

If the engine is to be stored in, or shipped to an area with below freezing temperatures, the cooling system must be either protected to the lowest outside temperature or drained completely to prevent damage.

NOTICE

Frequently check the specific gravity of the coolant for proper freeze protection or for anti-boil protection.

Clean the cooling system for the following reasons:

- Contamination of the cooling system
- Overheating of the engine
- Foaming of the coolant

NOTICE

Never operate an engine without water temperature regulators in the cooling system. Water temperature regulators help to maintain the engine coolant at the proper operating temperature. Cooling system problems can develop without water temperature regulators.

Many engine failures are related to the cooling system. The following problems are related to cooling system failures: Overheating, leakage of the water pump and plugged radiators or heat exchangers.

These failures can be avoided with correct cooling system maintenance. Cooling system maintenance is as important as maintenance of the fuel system and the lubrication system. Quality of the coolant is as important as the quality of the fuel and the lubricating oil.

Coolant is normally composed of three elements: Water, additives and glycol.

Water

Water is used in the cooling system in order to transfer heat.

Distilled water or deionized water is recommended for use in engine cooling systems.

DO NOT use the following types of water in cooling systems: Hard water, softened water that has been conditioned with salt and sea water.

If distilled water or deionized water is not available, use water with the properties that are listed in Table 14.

Table 14

Acceptable Water	
Property	Maximum Limit
Chloride (Cl)	40 mg/L
Sulfate (SO ₄)	100 mg/L
Total Hardness	170 mg/L
Total Solids	340 mg/L
Acidity	pH of 5.5 to 9.0

For a water analysis, consult one of the following sources:

- Local water utility company
- Agricultural agent
- Independent laboratory

Additives

Additives help to protect the metal surfaces of the cooling system. A lack of coolant additives or insufficient amounts of additives enable the following conditions to occur:

- Corrosion
- Formation of mineral deposits
- Rust
- Scale
- Foaming of the coolant

Many additives are depleted during engine operation. These additives must be replaced periodically.

Additives must be added at the correct concentration. Over concentration of additives can cause the inhibitors to drop out-of-solution. The deposits can enable the following problems to occur:

- Formation of gel compounds
- Reduction of heat transfer
- Leakage of the water pump seal
- Plugging of radiators, coolers, and small passages

Glycol

Glycol in the coolant helps to provide protection against the following conditions:

- Boiling
- Freezing

- Cavitation of the water pump

For optimum performance, Perkins recommends a 1:1 mixture of a water/glycol solution.

Note: Use a mixture that will provide protection against the lowest ambient temperature.

Note: 100 percent pure glycol will freeze at a temperature of -23 °C (-9 °F).

Most conventional antifreezes use ethylene glycol. Propylene glycol may also be used. In a 1:1 mixture with water, ethylene and propylene glycol provide similar protection against freezing and boiling. Refer to Table 15 and refer to table 16 .

Table 15

Ethylene Glycol	
Concentration	Freeze Protection
50 Percent	-36 °C (-33 °F)
60 Percent	-51 °C (-60 °F)

NOTICE

Do not use propylene glycol in concentrations that exceed 50 percent glycol because of the reduced heat transfer capability of propylene glycol. Use ethylene glycol in conditions that require additional protection against boiling or freezing.

Table 16

Propylene Glycol	
Concentration	Freeze Protection
50 Percent	-29 °C (-20 °F)

To check the concentration of glycol in the coolant, measure the specific gravity of the coolant.

Coolant Recommendations

- ELC_____Extended Life Coolant
- SCA_____Supplement Coolant Additive
- ASTM_____American Society for Testing and Materials

The following two coolants are used in Perkins diesel engines:

Preferred – Perkins ELC

Acceptable – A commercial heavy-duty antifreeze that meets “ASTM D6210” specifications

NOTICE

The 400F industrial engines must be operated with a 1:1 mixture of water and glycol. This concentration allows the NOx reduction system to operate correctly at high ambient temperatures.

NOTICE

Do not use a commercial coolant/antifreeze that only meets the ASTM D3306 specification. This type of coolant/antifreeze is made for light automotive applications.

Perkins recommends a 1:1 mixture of water and glycol. This mixture of water and glycol will provide optimum heavy-duty performance as an antifreeze. This ratio may be increased to 1:2 water to glycol if extra freezing protection is required.

A mixture of SCA inhibitor and water is acceptable but will not give the same level of corrosion, boiling and, freezing protection as ELC. Perkins recommends a 6 percent to 8 percent concentration of SCA in those cooling systems. Distilled water or deionized water is preferred. Water which has the recommended properties may be used

Table 17

Coolant Service Life	
Coolant Type	Service Life ⁽¹⁾
Perkins ELC	6,000 Service Hours or Three Years
Commercial Heavy-Duty Antifreeze that meets “ASTM D6210”	3000 Service Hours or Two Years
A Perkins approved SCA inhibitor	3000 Service Hours or Two Years

⁽¹⁾ Use the interval that occurs first. The cooling system must also be flushed out at this time.

ELC

Perkins provides ELC for use in the following applications:

- Heavy-duty spark ignited gas engines
- Heavy-duty diesel engines
- Automotive applications

The anti-corrosion package for ELC is different from the anti-corrosion package for other coolants. ELC is an ethylene glycol base coolant. However, ELC contains organic corrosion inhibitors and antifoam agents with low amounts of nitrite. Perkins ELC has been formulated with the correct amount of these additives in order to provide superior corrosion protection for all metals in engine cooling systems.

ELC is available in a premixed cooling solution with distilled water. ELC is a 1:1 mixture. The Premixed ELC provides freeze protection to $-36\text{ }^{\circ}\text{C}$ ($-33\text{ }^{\circ}\text{F}$). The Premixed ELC is recommended for the initial fill of the cooling system. The Premixed ELC is also recommended for topping off the cooling system.

Containers of several sizes are available. Consult your Perkins distributor for the part numbers.

ELC Cooling System Maintenance

Correct additions to the Extended Life Coolant

NOTICE

Use only Perkins products for pre-mixed or concentrated coolants.

Mixing Extended Life Coolant with other products reduces the Extended Life Coolant service life. Failure to follow the recommendations can reduce cooling system components life unless appropriate corrective action is performed.

In order to maintain the correct balance between the antifreeze and the additives, you must maintain the recommended concentration of ELC. Lowering the proportion of antifreeze lowers the proportion of additive. This action will lower the ability of the coolant to protect the system from pitting, from cavitation, from erosion, and from deposits.

NOTICE

Do not use a conventional coolant to top-off a cooling system that is filled with Extended Life Coolant (ELC).

Do not use standard supplemental coolant additive (SCA).

When using Perkins ELC, do not use standard SCA's or SCA filters.

ELC Cooling System Cleaning

Note: If the cooling system is already using ELC, cleaning agents are not required to be used at the specified coolant change interval. Cleaning agents are only required if the system has been contaminated by the addition of some other type of coolant or by cooling system damage.

Clean water is the only cleaning agent that is required when ELC is drained from the cooling system.

Before the cooling system is filled, the heater control (if equipped) must be set to the HOT position. Refer to the OEM in order to set the heater control. After the cooling system is drained and the cooling system is refilled, operate the engine until the coolant level reaches the normal operating temperature and until the coolant level stabilizes. As needed, add the coolant mixture in order to fill the system to the specified level.

Changing to Perkins ELC

To change from heavy-duty antifreeze to the Perkins ELC, perform the following steps:

NOTICE

Care must be taken to ensure that all fluids are contained during performance of inspection, maintenance, testing, adjusting and the repair of the product. Be prepared to collect the fluid with suitable containers before opening any compartment or disassembling any component containing fluids.

Dispose of all fluids according to local regulations and mandates.

-
1. Drain the coolant into a suitable container.
 2. Dispose of the coolant according to local regulations.
 3. Flush the system with clean water in order to remove any debris.
 4. Use Perkins cleaner to clean the system. Follow the instruction on the label.
 5. Drain the cleaner into a suitable container. Flush the cooling system with clean water.
 6. Fill the cooling system with clean water and operate the engine until the engine is warmed to 49° to 66°C (120° to 150°F).

NOTICE

Incorrect or incomplete flushing of the cooling system can result in damage to copper and other metal components.

To avoid damage to the cooling system, make sure to completely flush the cooling system with clear water. Continue to flush the system until all the signs of the cleaning agent are gone.

-
7. Drain the cooling system into a suitable container and flush the cooling system with clean water.

Note: The cooling system cleaner must be thoroughly flushed from the cooling system. Cooling system cleaner that is left in the system will contaminate the coolant. The cleaner may also corrode the cooling system.

8. Repeat Steps 6 and repeat steps 7 until the system is completely clean.
9. Fill the cooling system with the Perkins Premixed ELC.

ELC Cooling System Contamination

NOTICE

Mixing ELC with other products reduces the effectiveness of the ELC and shortens the ELC service life. Use only Perkins Products for premixed or concentrate coolants. Failure to follow these recommendations can result in shortened cooling system component life.

ELC cooling systems can withstand contamination to a maximum of 10 percent of conventional heavy-duty antifreeze or SCA. If the contamination exceeds 10 percent of the total system capacity, perform ONE of the following procedures:

- Drain the cooling system into a suitable container. Dispose of the coolant according to local regulations. Flush the system with clean water. Fill the system with the Perkins ELC.
- Drain a portion of the cooling system into a suitable container according to local regulations. Then, fill the cooling system with premixed ELC. This procedure should lower the contamination to less than 10 percent.
- Maintain the system as a conventional Heavy-Duty Coolant. Treat the system with an SCA. Change the coolant at the interval that is recommended for the conventional Heavy-Duty Coolant.

Commercial Heavy-Duty Antifreeze and SCA

NOTICE

Commercial Heavy-Duty Coolant which contains Amine as part of the corrosion protection system must not be used.

NOTICE

Never operate an engine without water temperature regulators in the cooling system. Water temperature regulators help to maintain the engine coolant at the correct operating temperature. Cooling system problems can develop without water temperature regulators.

Check the antifreeze (glycol concentration) in order to ensure adequate protection against boiling or freezing. Perkins recommends the use of a refractometer for checking the glycol concentration. A hydrometer should not be used.

Perkins engine cooling systems should be tested at 500 hour intervals for the concentration of SCA.

Additions of SCA are based on the results of the test. An SCA that is liquid may be needed at 500 hour intervals.

Adding the SCA to Heavy-Duty Coolant at the Initial Fill

Commercial heavy-duty antifreeze that meets "ASTM D4985" specifications MAY require an addition of SCA at the initial fill. Read the label or the instructions that are provided by the OEM of the product.

Use the equation that is in Table 18 to determine the amount of Perkins SCA that is required when the cooling system is initially filled.

Table 18

Equation For Adding The SCA To The Heavy-Duty Coolant At The Initial Fill
$V \times 0.045 = X$
V is the total volume of the cooling system.
X is the amount of SCA that is required.

Table 19 is an example for using the equation that is in Table 18 .

Table 19

Example Of The Equation For Adding The SCA To The Heavy-Duty Coolant At The Initial Fill		
Total Volume of the Cooling System (V)	Multiplication Factor	Amount of SCA that is Required (X)
15 L (4 US gal)	× 0.045	0.7 L (24 oz)

Adding The SCA to The Heavy-Duty Coolant For Maintenance

Heavy-duty antifreeze of all types REQUIRE periodic additions of an SCA.

Test the antifreeze periodically for the concentration of SCA. For the interval, refer to the Operation and Maintenance Manual, "Maintenance Interval Schedule" (Maintenance Section). Test the concentration of SCA.

Additions of SCA are based on the results of the test. The size of the cooling system determines the amount of SCA that is needed.

Use the equation that is in Table 20 to determine the amount of Perkins SCA that is required, if necessary:

Table 20

Equation For Adding The SCA To The Heavy-Duty Coolant For Maintenance
$V \times 0.014 = X$
V is the total volume of the cooling system.
X is the amount of SCA that is required.

Table 21 is an example for using the equation that is in Table 20 .

Table 21

Example Of The Equation For Adding The SCA To The Heavy-Duty Coolant For Maintenance		
Total Volume of the Cooling System (V)	Multiplication Factor	Amount of SCA that is Required (X)
15 L (4 US gal)	× 0.014	0.2 L (7 oz)

Cleaning the System of Heavy-Duty Antifreeze

Perkins cooling system cleaners are designed to clean the cooling system of harmful scale and corrosion. Perkins cooling system cleaners dissolve mineral scale, corrosion products, light oil contamination, and sludge.

- Clean the cooling system after used coolant is drained or before the cooling system is filled with new coolant.
- Clean the cooling system whenever the coolant is contaminated or whenever the coolant is foaming.

Maintenance Recommendations

i04056177

System Pressure Release

Coolant System

WARNING

Pressurized system: Hot coolant can cause serious burn. To open cap, stop engine, wait until radiator is cool. Then loosen cap slowly to relieve the pressure.

Ensure that the power supply is isolated before any service or repair is performed.

To relieve the pressure from the coolant system, turn off the engine. Allow the cooling system pressure cap to cool. Remove the cooling system pressure cap slowly in order to relieve pressure.

Fuel System

To relieve the pressure from the fuel system, turn off the engine.

Engine Oil

To relieve pressure from the lubricating system, turn off the engine.

i04055929

Welding on Engines with Electronic Controls

Correct welding procedures are necessary in order to avoid damage to the following components:

- Electronic Control Module (ECM) on the engine
- Clean Emissions Module (CEM)
- Sensors
- Associated components

Components for the driven equipment should also be considered. When possible, remove the component that requires welding. When welding on an engine that is equipped with an ECM and removal of the component is not possible, the following procedure must be followed. This procedure minimizes the risk to the electronic components.

1. Stop the engine. Remove the electrical power from the ECM.
2. Ensure that the fuel supply to the engine is turned off.
3. Disconnect the negative battery cable from the battery. If a battery disconnect switch is installed, open the switch.
4. Disconnect all electronic components from the wiring harnesses. Include the following components:
 - Electronic components for the driven equipment
 - ECM
 - Sensors
 - Electronically controlled valves
 - Relays
 - Aftertreatment ID module

NOTICE

Do not use electrical components (ECM or ECM sensors) or electronic component grounding points for grounding the welder.

i04150276

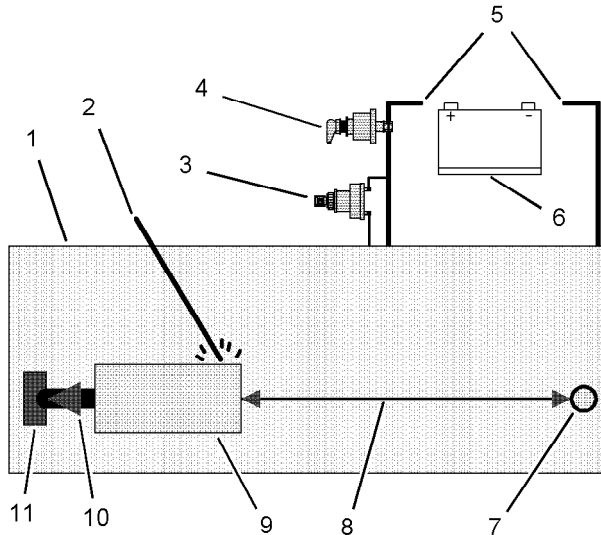

Illustration 41

g01075639

Use the example above. The current flow from the welder to the ground clamp of the welder will not damage any associated components.

- (1) Engine
- (2) Welding electrode
- (3) Keyswitch in the OFF position
- (4) Battery disconnect switch in the open position
- (5) Disconnected battery cables
- (6) Battery
- (7) Electrical/Electronic component
- (8) Minimum distance between the component that is being welded and any electrical/electronic component
- (9) The component that is being welded
- (10) Current path of the welder
- (11) Ground clamp for the welder

5. When possible, connect the ground clamp for the welding equipment directly to the engine component that will be welded. Place the clamp as close as possible to the weld. Close positioning reduces the risk of welding current damage to the engine bearings, to the electrical components, and to other components.
6. Protect the wiring harnesses from welding debris and/or from welding spatter.
7. Use standard welding procedures to weld the materials together.

Severe Service Application

Severe service is the application of an engine that exceeds the current published standards for that engine. Perkins maintains standards for the following engine parameters:

- Performance such as power range, speed range, and fuel consumption
- Fuel quality
- Operational Altitude
- Maintenance intervals
- Oil selection and maintenance
- Coolant type and maintenance
- Environmental qualities
- Installation
- The temperature of the fluid in the engine

Refer to the standards for the engine or consult your Perkins dealer or your Perkins distributor in order to determine if the engine is operating within the defined parameters.

Severe service operation can accelerate component wear. Engines that operate under severe conditions may need more frequent maintenance intervals in order to ensure maximum reliability and retention of full service life.

Due to individual applications, it is not possible to identify all of the factors which can contribute to severe service operation. Consult your Perkins dealer or your Perkins distributor for the unique maintenance that is necessary for the engine.

The operating environment, incorrect operating procedures, and incorrect maintenance procedures can be factors which contribute to a severe service application.

Environmental Factors

Ambient temperatures – The engine may be exposed to extended operation in cold environments or hot environments. Valve components can be damaged by carbon buildup if the engine is frequently started and stopped in cold temperatures. Hot intake air reduces engine performance.

Quality of the air – The engine may be exposed to extended operation in an environment that is dirty or dusty, unless the equipment is cleaned regularly. Mud, dirt, and dust can encase components.

Maintenance can be difficult. The buildup can contain corrosive chemicals.

Buildup – Compounds, elements, corrosive chemicals, and salt can damage some components.

Altitude – Problems can arise when the engine is operated at altitudes that are higher than the intended settings for that application. Necessary adjustments should be made.

Incorrect Operating Procedures

- Extended operation at low idle
- Frequent hot shutdowns
- Operating at excessive loads
- Operating at excessive speeds
- Operating outside the intended application

Incorrect Maintenance Procedures

- Extending the maintenance intervals
- Failure to use recommended fuel, lubricants, and coolant/antifreeze

i08323395

Maintenance Interval Schedule

When Required

“ Battery - Replace“	76
“ Battery or Battery Cable - Disconnect“	77
“ Engine - Clean“	87
“ Fuel System - Prime“	94

Daily

“ Coolant Level - Check“	82
“ Engine Air Cleaner Service Indicator - Inspect“	88
“ Engine Air Precleaner - Check/Clean“	88
“ Engine Oil Level - Check“	89
“ Walk-Around Inspection“	104

Every 50 Service Hours or Weekly

“ Fuel Tank Water and Sediment - Drain“	100
---	-----

Every 250 Service Hours or 6 Months

“ Alternator and Fan Belts - Inspect/Adjust“	75
“ Belts - Inspect/Adjust/Replace“	77

Every 500 Service Hours

“ Engine Air Cleaner Element - Replace“	88
“ Fan Clearance - Check“	92
“ Fuel Filter (In-Line) - Replace“	92
“ Fuel System Secondary Filter - Replace“	99

Every 500 Service Hours or 1 Year

“ Battery Electrolyte Level - Check“	77
“ Cooling System Supplemental Coolant Additive (SCA) - Test/Add“	84
“ Engine Oil and Filter - Change“	89
“ Hoses and Clamps - Inspect/Replace“	101

“ Radiator - Clean“	102
---------------------	-----

Every 1000 Service Hours

“ Alternator and Fan Belts - Replace“	76
“ Belts - Inspect/Replace“	78
“ Crankcase Breather (Canister) - Replace“	85
“ Engine Valve Lash - Check“	91
“ Turbocharger - Inspect“	103

Every 2000 Service Hours

“ Alternator - Inspect“	75
“ Engine Mounts - Inspect“	89
“ Starting Motor - Inspect“	103

Every 3000 Service Hours

“ Coolant Temperature Regulator - Replace“	83
“ Diesel Particulate Filter - Clean“	86
“ Fuel Injector - Test/Change“	93
“ Glow Plugs (ARD Combustion) - Replace“	100
“ Radiator Pressure Cap - Clean/Replace“	103
“ Water Pump - Inspect“	105

Every 3000 Service Hours or 2 Years

“ Coolant (Commercial Heavy-Duty) - Change“	79
---	----

Every 6000 Service Hours or 3 Years

“ Coolant (ELC) - Change“	80
---------------------------	----

Commissioning

“ Fan Clearance - Check“	92
--------------------------	----

i02322311

Alternator - Inspect

Perkins recommends a scheduled inspection of the alternator. Inspect the alternator for loose connections and correct battery charging. Check the ammeter (if equipped) during engine operation in order to ensure correct battery performance and/or correct performance of the electrical system. Make repairs, as required.

Check the alternator and the battery charger for correct operation. If the batteries are correctly charged, the ammeter reading should be very near zero. All batteries should be kept charged. The batteries should be kept warm because temperature affects the cranking power. If the battery is too cold, the battery will not crank the engine. When the engine is not run for long periods of time or if the engine is run for short periods, the batteries may not fully charge. A battery with a low charge will freeze more easily than a battery with a full charge.

i05162309

Alternator and Fan Belts - Inspect/Adjust

Inspection

To maximize the engine performance, inspect the belt for wear and for cracking. Replace a belt that is worn or damaged.

If a belt is too loose, vibration causes unnecessary wear on the belt and pulleys. Loose belts may slip enough to cause overheating.

To accurately check the belt tension, a suitable gauge should be used.

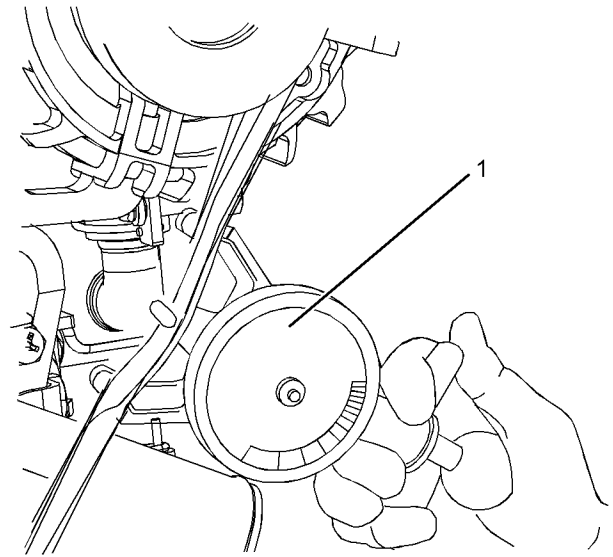

Illustration 42

g03316638

Typical example

(1) Burroughs Gauge

Install the gauge (1) at the center of the belt between the alternator and the crankshaft pulley and check the belt tension. The correct tension for a new belt is 400 N (90 lb) to 489 N (110 lb). The correct tension for a used belt that has been in operation for 30 minutes or more at the rated speed is 267 N (60 lb) to 356 N (80 lb).

Adjustment

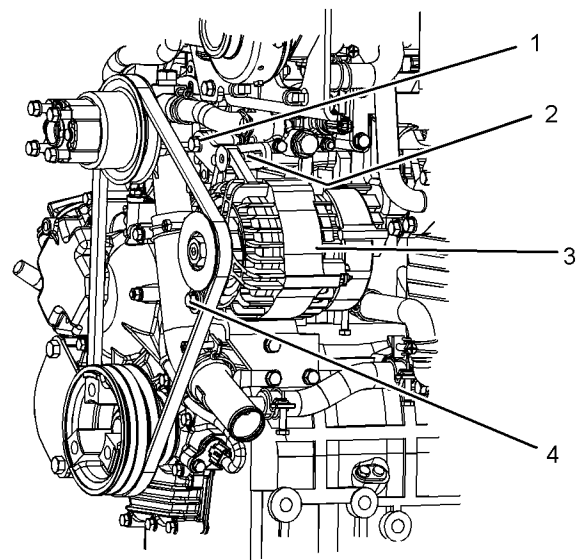

Illustration 43

g03316634

1. Loosen bolts (1) and adjusting bolt (2). Loosen bolt (4).

2. Move the alternator (3) in order to increase or decrease the belt tension.
3. Tighten adjusting bolt (2). Tighten bolts (1) and tighten bolt (4). Refer to the Specifications Manual for the correct torque settings.

i05162326

Alternator and Fan Belts - Replace

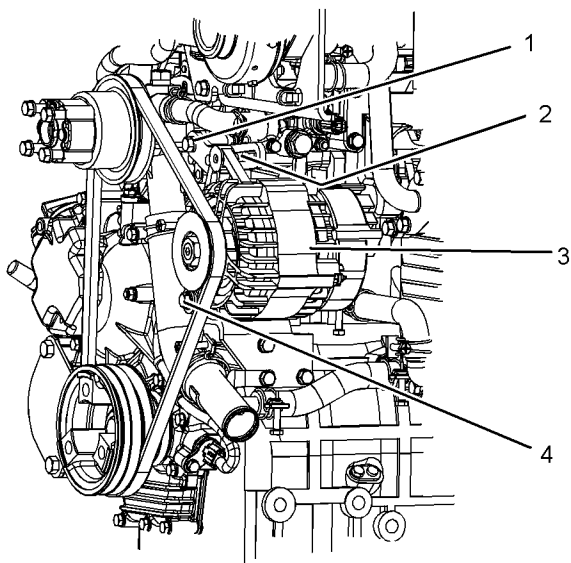

Illustration 44

g03316634

- (1) Securing bolt
- (2) Adjusting bolt
- (3) Alternator
- (4) Lower securing bolt

The air pump belt must be removed before the fan belt can be removed.

Refer to the Disassembly and Assembly Manual for the installation procedure and the removal procedure for both belts.

i02322315

Battery - Replace

WARNING

Batteries give off combustible gases which can explode. A spark can cause the combustible gases to ignite. This can result in severe personal injury or death.

Ensure proper ventilation for batteries that are in an enclosure. Follow the proper procedures in order to help prevent electrical arcs and/or sparks near batteries. Do not smoke when batteries are serviced.

WARNING

The battery cables or the batteries should not be removed with the battery cover in place. The battery cover should be removed before any servicing is attempted.

Removing the battery cables or the batteries with the cover in place may cause a battery explosion resulting in personal injury.

1. Switch the engine to the OFF position. Remove all electrical loads.
2. Turn off any battery chargers. Disconnect any battery chargers.
3. The NEGATIVE “-” cable connects the NEGATIVE “-” battery terminal to the NEGATIVE “-” terminal on the starting motor. Disconnect the cable from the NEGATIVE “-” battery terminal.
4. The POSITIVE “+” cable connects the POSITIVE “+” battery terminal to the POSITIVE “+” terminal on the starting motor. Disconnect the cable from the POSITIVE “+” battery terminal.

Note: Always recycle a battery. Never discard a battery. Dispose of used batteries to an appropriate recycling facility.

5. Remove the used battery.
6. Install the new battery.

Note: Before the cables are connected, ensure that the engine start switch is OFF.

7. Connect the cable from the starting motor to the POSITIVE “+” battery terminal.
8. Connect the NEGATIVE “-” cable to the NEGATIVE “-” battery terminal.

i02747977

i07819485

Battery Electrolyte Level - Check

When the engine is not run for long periods of time or when the engine is run for short periods, the batteries may not fully recharge. Ensure a full charge in order to help prevent the battery from freezing. If batteries are correctly charged, the ammeter reading should be very near zero, when the engine is in operation.

WARNING

All lead-acid batteries contain sulfuric acid which can burn the skin and clothing. Always wear a face shield and protective clothing when working on or near batteries.

1. Remove the filler caps. Maintain the electrolyte level to the "FULL" mark on the battery.

If the addition of water is necessary, use distilled water. If distilled water is not available use clean water that is low in minerals. Do not use artificially softened water.

2. Check the condition of the electrolyte with a suitable battery tester.

3. Install the caps.

4. Keep the batteries clean.

Clean the battery case with one of the following cleaning solutions:

- Use a solution of 0.1 kg (0.2 lb) baking soda and 1 L (1 qt) of clean water.
- Use a solution of ammonium hydroxide.

Thoroughly rinse the battery case with clean water.

Battery or Battery Cable - Disconnect

WARNING

The battery cables or the batteries should not be removed with the battery cover in place. The battery cover should be removed before any servicing is attempted.

Removing the battery cables or the batteries with the cover in place may cause a battery explosion resulting in personal injury.

1. Turn the start switch to the OFF position. Turn the ignition switch (if equipped) to the OFF position and remove the key and all electrical loads.
2. Disconnect the negative battery terminal. Ensure that the cable cannot contact the terminal. When four 12 volt batteries are involved, two negative connection must be disconnected.
3. Remove the positive connection.
4. Clean all disconnected connection and battery terminals.
5. Use a fine grade of sandpaper to clean the terminals and the cable clamps. Clean the items until the surfaces are bright or shiny. DO NOT remove material excessively. Excessive removal of material can cause the clamps to not fit correctly. Coat the clamps and the terminals with a suitable silicone lubricant or petroleum jelly.
6. Tape the cable connections to help prevent accidental starting.
7. Proceed with necessary system repairs.
8. To connect the battery, connect the positive connection before the negative connection.

i05555031

Belts - Inspect/Adjust/Replace (Air Pump Belt)

Inspection

To maximize the engine performance, inspect the belt for wear and for cracking. Replace a belt that is worn or damaged.

If the belt is too loose, vibration causes unnecessary wear on the belt and pulleys. A loose belt may slip enough to cause issues within the aftertreatment system.

Adjust

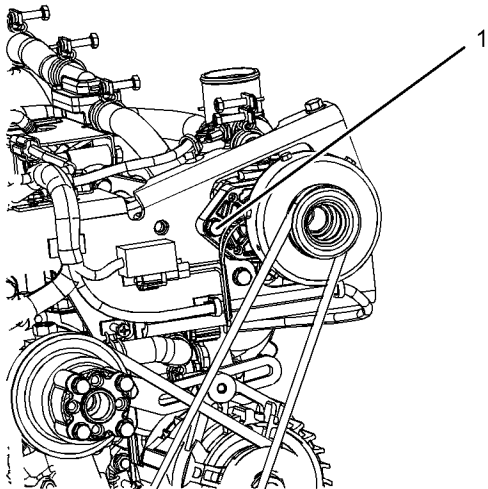

Illustration 45

g03316723

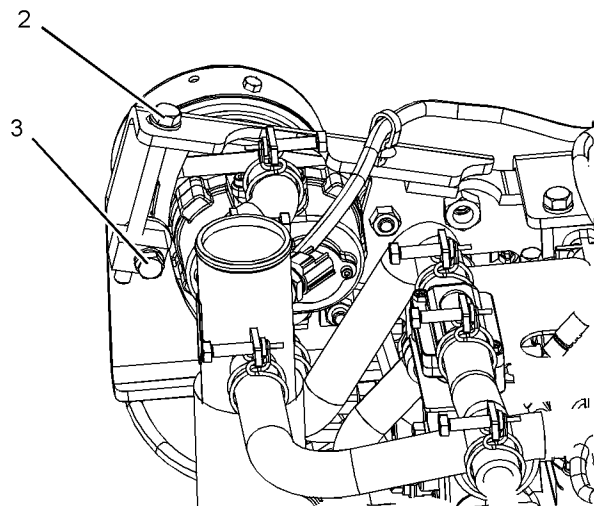

Illustration 46

g03316722

1. Loosen bolt (1) and loosen bolt (3).
2. Adjust bolt (2) in order to tension the belt.
3. Tighten bolt (1) and bolt (3) securely.

Replace Belt

The belt should only be replaced if the belt is worn or damaged. Refer to this Operation and Maintenance Manual, "Belts - Inspect/Replace (Air Pump Belt)" for more information.

Belt Tension Frequency

The belt for the air pump must be checked with a suitable belt tensioner meter. The meter checks the vibration frequency of the belt in order to determine the belt tension.

Refer to table 22 for three cylinder engines. Refer to table 23 for four cylinder engines.

Table 22

3 Cylinder Engines			
High Mounted Air Pump	Low Mounted Air Pump	Frequency Range for a New Belt	Frequency Range for a Used Belt
X	-	85-90 Hz	70-75 Hz
-	X	175-180 Hz	147-152 Hz

Table 23

4 Cylinder Engines			
High Mounted Air Pump	Low Mounted Air Pump	Frequency Range for a New Belt	Frequency Range for a Used Belt
X	-	77-82 Hz	65-70 Hz
-	X	175-180 Hz	147-152 Hz

i05558213

Belts - Inspect/Replace (Air Pump belt)

The air pump belt must be replaced at 1000 hours. Refer to Disassembly and Assembly, "Belt (Air Pump) - Remove and Install" for more information.

Belt Tension Frequency

The belt for the air pump must be checked with a suitable belt tensioner meter. The meter checks the vibration frequency of the belt in order to determine the belt tension.

Refer to table 24 for three cylinder engines. Refer to table 25 for four cylinder engines.

Table 24

3 Cylinder Engines			
High Mounted Air Pump	Low Mounted Air Pump	Frequency Range for a New Belt	Frequency Range for a Used Belt
X	-	85-90 Hz	70-75 Hz
-	X	175-180 Hz	147-152 Hz

Table 25

4 Cylinder Engines			
High Mounted Air Pump	Low Mounted Air Pump	Frequency Range for a New Belt	Frequency Range for a Used Belt
X	-	77-82 Hz	65-70 Hz
-	X	175-180 Hz	147-152 Hz

i05160093

Coolant (Commercial Heavy-Duty) - Change

NOTICE

Care must be taken to ensure that fluids are contained during performance of inspection, maintenance, testing, adjusting and repair of the product. Be prepared to collect the fluid with suitable containers before opening any compartment or disassembling any component containing fluids.

Dispose of all fluids according to Local regulations and mandates.

NOTICE

Keep all parts clean from contaminants.

Contaminants may cause rapid wear and shortened component life.

Clean the cooling system and flush the cooling system before the recommended maintenance interval if the following conditions exist:

- The engine overheats frequently.
- Foaming is observed.
- The oil has entered the cooling system and the coolant is contaminated.
- The fuel has entered the cooling system and the coolant is contaminated.

Note: When the cooling system is cleaned, only clean water is needed.

Note: Inspect the water pump and the water temperature regulator after the cooling system has been drained. This inspection is a good opportunity to replace the water pump, the water temperature regulator, and the hoses, if necessary.

Drain

WARNING

Pressurized System: Hot coolant can cause serious burns. To open the cooling system filler cap, stop the engine and wait until the cooling system components are cool. Loosen the cooling system pressure cap slowly in order to relieve the pressure.

1. Stop the engine and allow the engine to cool. Loosen the cooling system filler cap slowly in order to relieve any pressure. Remove the cooling system filler cap.

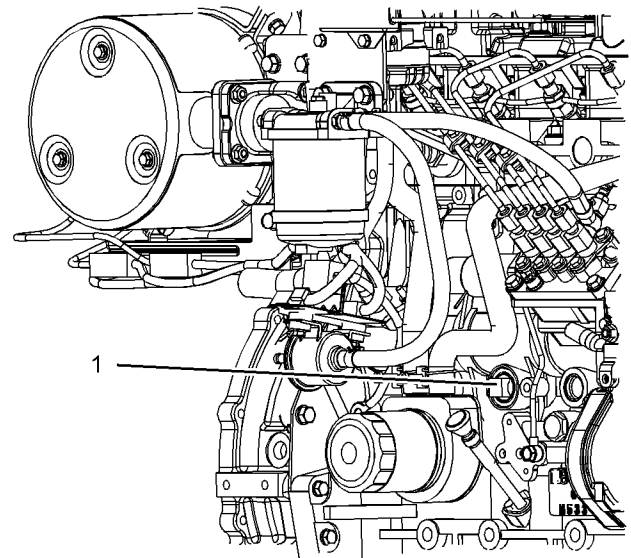

Illustration 47

g03305397

Typical example

2. Open the drain cock or remove the drain plug (1) on the engine. Open the drain cock or remove the drain plug on the radiator.

Allow the coolant to drain.

NOTICE

Dispose of used engine coolant or recycle. Various methods have been proposed to reclaim used coolant for reuse in engine cooling systems. The full distillation procedure is the only method acceptable by Perkins to reclaim the coolant.

For information regarding the disposal and the recycling of used coolant, consult your Perkins dealer or your Perkins distributor.

Flush

1. Flush the cooling system with clean water in order to remove any debris.
 2. Close the drain cock or install the drain plug in the engine. Close the drain cock or install the drain plug on the radiator.
-

NOTICE

Do not fill the cooling system faster than 5 L (1.3 US gal) per minute to avoid air locks.

Cooling system air locks may result in engine damage.

3. Fill the cooling system with clean water. Install the cooling system filler cap.
4. Start and run the engine at low idle until the temperature reaches 49 to 66 °C (120 to 150 °F).
5. Stop the engine and allow the engine to cool. Loosen the cooling system filler cap slowly in order to relieve any pressure. Remove the cooling system filler cap. Open the drain cock or remove the drain plug on the engine. Open the drain cock or remove the drain plug on the radiator. Allow the water to drain. Flush the cooling system with clean water.

Fill

1. Close the drain cock or install the drain plug on the engine. Close the drain cock or install the drain plug on the radiator.
-

NOTICE

Do not fill the cooling system faster than 5 L (1.3 US gal) per minute to avoid air locks.

Cooling system air locks may result in engine damage.

2. Fill the cooling system with Commercial Heavy-Duty Coolant. Add Supplemental Coolant Additive to the coolant. For the correct amount, refer to the Operation and Maintenance Manual, "Fluid Recommendations" topic (Maintenance Section) for more information on cooling system specifications. Do not install the cooling system filler cap.
3. Start and run the engine at low idle. Increase the engine rpm to high idle. Run the engine at high idle for 1 minute in order to purge the air from the cavities of the engine block. Stop the engine.
4. Check the coolant level. Maintain the coolant level within 13 mm (0.5 inch) below the bottom of the pipe for filling. Maintain the coolant level in the expansion bottle (if equipped) at the correct level.
5. Clean the cooling system filler cap. Inspect the gasket that is on the cooling system filler cap. If the gasket that is on the cooling system filler cap is damaged, discard the old cooling system filler cap and install a new cooling system filler cap. If the gasket that is on the cooling system filler cap is not damaged, use a suitable pressurizing pump in order to pressure test the cooling system filler cap. The correct pressure for the cooling system filler cap is stamped on the face of the cooling system filler cap. If the cooling system filler cap does not retain the correct pressure, install a new cooling system filler cap.
6. Start the engine. Inspect the cooling system for leaks and for correct operating temperature.

i05149269

Coolant (ELC) - Change

NOTICE

Care must be taken to ensure that fluids are contained during performance of inspection, maintenance, testing, adjusting and repair of the product. Be prepared to collect the fluid with suitable containers before opening any compartment or disassembling any component containing fluids.

Dispose of all fluids according to Local regulations and mandates.

NOTICE

Keep all parts clean from contaminants.

Contaminants may cause rapid wear and shortened component life.

Clean the cooling system and flush the cooling system before the recommended maintenance interval if the following conditions exist:

- The engine overheats frequently.
- Foaming is observed.
- The oil has entered the cooling system and the coolant is contaminated.
- The fuel has entered the cooling system and the coolant is contaminated.

Note: When the cooling system is cleaned, only clean water is needed when the Extended Life Coolant (ELC) is drained and replaced.

Note: Inspect the water pump and the water temperature regulator after the cooling system has been drained. This inspection is a good opportunity to replace the water pump, the water temperature regulator, and the hoses, if necessary.

Drain

WARNING

Pressurized System: Hot coolant can cause serious burns. To open the cooling system filler cap, stop the engine and wait until the cooling system components are cool. Loosen the cooling system pressure cap slowly in order to relieve the pressure.

1. Stop the engine and allow the engine to cool. Loosen the cooling system filler cap slowly in order to relieve any pressure. Remove the cooling system filler cap.

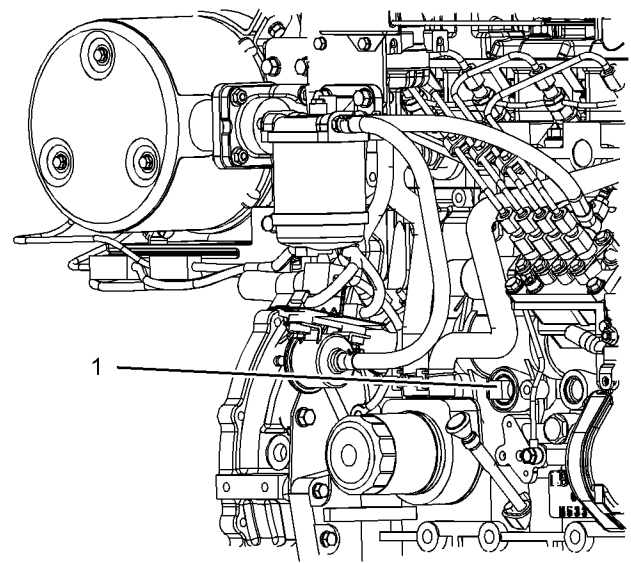

Illustration 48

g03305397

Typical example

2. Open the drain cock or remove the drain plug (1) on the engine. Open the drain cock or remove the drain plug on the radiator.

Allow the coolant to drain.

NOTICE

Dispose of used engine coolant or recycle. Various methods have been proposed to reclaim used coolant for reuse in engine cooling systems. The full distillation procedure is the only method acceptable by Perkins to reclaim the coolant.

For information regarding the disposal and the recycling of used coolant, consult your Perkins dealer or your Perkins distributor.

Flush

1. Flush the cooling system with clean water in order to remove any debris.
2. Close the drain cock or install the drain plug in the engine. Close the drain cock or install the drain plug on the radiator.

NOTICE

Do not fill the cooling system faster than 5 L (1.3 US gal) per minute to avoid air locks.

Cooling system air locks may result in engine damage.

3. Fill the cooling system with clean water. Install the cooling system filler cap.

4. Start and run the engine at low idle until the temperature reaches 49 to 66 °C (120 to 150 °F).
5. Stop the engine and allow the engine to cool. Loosen the cooling system filler cap slowly in order to relieve any pressure. Remove the cooling system filler cap. Open the drain cock or remove the drain plug on the engine. Open the drain cock or remove the drain plug on the radiator. Allow the water to drain. Flush the cooling system with clean water.

Fill

1. Close the drain cock or install the drain plug on the engine. Close the drain cock or install the drain plug on the radiator.

NOTICE

Do not fill the cooling system faster than 5 L (1.3 US gal) per minute to avoid air locks.

Cooling system air locks may result in engine damage.

2. Fill the cooling system with ELC. Refer to the Operation and Maintenance Manual, "Fluid Recommendations" topic (Maintenance Section) for more information on cooling system specifications. Do not install the cooling system filler cap.
3. Start and operate the engine at low idle. Increase the engine rpm to high idle. Operate the engine at high idle for 1 minute in order to purge the air from the cavities of the engine block. Stop the engine.
4. Check the coolant level. Maintain the coolant level within 13 mm (0.5 inch) below the bottom of the pipe for filling. Maintain the coolant level in the expansion bottle (if equipped) at the correct level.
5. Clean the cooling system filler cap. Inspect the gasket that is on the cooling system filler cap. If the gasket that is on the cooling system filler cap is damaged, discard the old cooling system filler cap and install a new cooling system filler cap. If the gasket that is on the cooling system filler cap is not damaged, use a suitable pressurizing pump in order to pressure test the cooling system filler cap. The correct pressure for the cooling system filler cap is stamped on the face of the cooling system filler cap. If the cooling system filler cap does not retain the correct pressure, install a new cooling system filler cap.

6. Start the engine. Inspect the cooling system for leaks and for correct operating temperature.

i05149389

Coolant Level - Check

Engines With a Coolant Recovery Tank

Note: The cooling system may not have been provided by Perkins. The procedure that follows is for typical cooling systems. Refer to the OEM information for the correct procedures.

Check the coolant level when the engine is stopped and cool.

NOTICE

When any servicing or repair of the engine cooling system is performed, the procedure must be performed with the engine on level ground. Level ground will allow you to check accurately the coolant level. This checking will also help in avoiding the risk of introducing an air lock into the coolant system.

1. Observe the coolant level in the coolant recovery tank. Maintain the coolant level to "COLD FULL" mark on the coolant recovery tank.

WARNING

Pressurized System: Hot coolant can cause serious burns. To open the cooling system filler cap, stop the engine and wait until the cooling system components are cool. Loosen the cooling system pressure cap slowly in order to relieve the pressure.

2. Loosen filler cap slowly in order to relieve any pressure. Remove the filler cap.
3. Pour the correct coolant mixture into the tank. Refer to the Operation and Maintenance Manual, "Refill Capacities and Recommendations" for information on the correct mixture and type of coolant. Refer to the Operation and Maintenance Manual, "Refill Capacities and Recommendations" for the engine cooling system capacity. Do not fill the coolant recovery tank above "COLD FULL" mark.

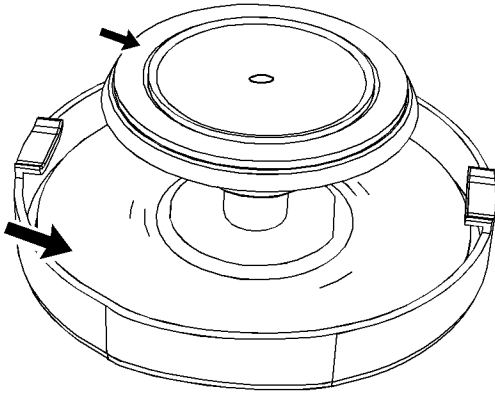

Illustration 49

g02590196

Filler cap

4. Clean the filler cap and the receptacle. Reinstall the filler cap and inspect the cooling system for leaks.

Note: The coolant will expand as the coolant heats up during normal engine operation. The additional volume will be forced into the coolant recovery tank during engine operation. When the engine is stopped and cool, the coolant will return to the engine.

Engines Without a Coolant Recovery Tank

Check the coolant level when the engine is stopped and cool.

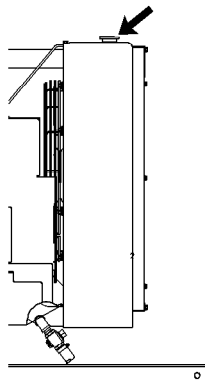

Illustration 50

g00285520

Cooling system filler cap

WARNING

Pressurized System: Hot coolant can cause serious burns. To open the cooling system filler cap, stop the engine and wait until the cooling system components are cool. Loosen the cooling system pressure cap slowly in order to relieve the pressure.

1. Remove the cooling system filler cap slowly in order to relieve pressure.
2. Maintain the coolant level at the maximum mark that is correct for your application. If the engine is equipped with a sight glass, maintain the coolant level to the correct level in the sight glass.
3. Clean the cooling system filler cap and inspect the gasket. If the gasket is damaged, discard the old filler cap and install a new filler cap. If the gasket is not damaged, use a suitable pressurizing pump in order to pressure test the filler cap. The correct pressure is stamped on the face of the filler cap. If the filler cap does not retain the correct pressure, install a new filler cap.
4. Inspect the cooling system for leaks.

i05160120

Coolant Temperature Regulator - Replace

Replace the water temperature regulator before the water temperature regulator fails. This is a recommended preventive maintenance practice. Replacing the water temperature regulator reduces the chances for unscheduled downtime.

A water temperature regulator that fails in a partially opened position can cause overheating or overcooling of the engine.

A water temperature regulator that fails in the closed position can cause excessive overheating. Excessive overheating could result in cracking of the cylinder head or piston seizure problems.

A water temperature regulator that fails in the open position will cause the engine operating temperature to be too low during partial load operation. Low engine operating temperatures during partial loads could cause an excessive carbon buildup inside the cylinders. This excessive carbon buildup could result in an accelerated wear of the piston rings and wear of the cylinder liner.

NOTICE

Failure to replace your water temperature regulator on a regularly scheduled basis could cause severe engine damage.

Perkins engines incorporate a shunt design cooling system and require operating the engine with a water temperature regulator installed.

If the water temperature regulator is installed incorrectly, the engine may overheat, causing cylinder head damage. Ensure that the new water temperature regulator is installed in the original position. Ensure that the water temperature regulator vent hole is open.

Do not use liquid gasket material on the gasket or cylinder head surface.

Refer to the Disassembly and Assembly Manual, "Water Temperature Regulator - Remove and Install" for the replacement procedure of the water temperature regulator, or consult your Perkins dealer or your Perkins distributor.

Note: If only the water temperature regulators are replaced, drain the coolant from the cooling system to a level that is below the water temperature regulator housing.

i03644948

Cooling System Supplemental Coolant Additive (SCA) - Test/Add

 **WARNING**

Cooling system coolant additive contains alkali. To help prevent personal injury, avoid contact with the skin and the eyes. Do not drink cooling system coolant additive.

Test for SCA Concentration

Heavy-Duty Coolant/Antifreeze and SCA

NOTICE

Do not exceed the recommended six percent supplemental coolant additive concentration.

Use a Coolant Conditioner Test Kit in order to check the concentration of the SCA.

Add the SCA, If Necessary

NOTICE

Do not exceed the recommended amount of supplemental coolant additive concentration. Excessive supplemental coolant additive concentration can form deposits on the higher temperature surfaces of the cooling system, reducing the engine's heat transfer characteristics. Reduced heat transfer could cause cracking of the cylinder head and other high temperature components. Excessive supplemental coolant additive concentration could also result in radiator tube blockage, overheating, and/or accelerated water pump seal wear. Never use both liquid supplemental coolant additive and the spin-on element (if equipped) at the same time. The use of those additives together could result in supplemental coolant additive concentration exceeding the recommended maximum.

 **WARNING**

Pressurized System: Hot coolant can cause serious burns. To open the cooling system filler cap, stop the engine and wait until the cooling system components are cool. Loosen the cooling system pressure cap slowly in order to relieve the pressure.

NOTICE

When any servicing or repair of the engine cooling system is performed the procedure must be performed with the engine on level ground. This will allow you to accurately check the coolant level. This will also help in avoiding the risk of introducing an air lock into the coolant system.

1. Slowly loosen the cooling system filler cap in order to relieve the pressure. Remove the cooling system filler cap.

Note: Always discard drained fluids according to local regulations.

2. If necessary, drain some coolant from the cooling system into a suitable container in order to allow space for the extra SCA.
3. Add the correct amount of SCA. Refer to the Operation and Maintenance Manual, "Refill Capacities and Recommendations" for more information on SCA requirements.

4. Clean the cooling system filler cap and inspect the gasket. If the gasket is damaged, discard the old filler cap and install a new filler cap. If the gasket is not damaged, use a suitable pressurizing pump in order to pressure test the filler cap. The correct pressure is stamped on the face of the filler cap. If the filler cap does not retain the correct pressure, install a new filler cap.

i07911164

Crankcase Breather (Canister) - Replace

WARNING

Hot oil and hot components can cause personal injury. Do not allow hot oil or hot components to contact the skin.

NOTICE

Ensure that the engine is stopped before any servicing or repair is performed.

NOTICE

Care must be taken to ensure that fluids are contained during performance of inspection, maintenance, testing, adjusting and repair of the product. Be prepared to collect the fluid with suitable containers before opening any compartment or disassembling any component containing fluids.

Dispose of all fluids according to local regulations and mandates.

The crankcase breather plays a major role in keeping your engine emissions compliant.

- The filter element within the crankcase breather must be serviced at the prescribed service interval.
- The correct filter element must be installed before the engine is operated.
- The installation of the filter element is critical to the correct operation of the engine.
- The quality of the filter element that is installed is very important, Perkins recommend using genuine Perkins filters.
- The filter element protects the engine from excessive quantities of oil from entering the induction system. The filter element also protects the engine aftertreatment system.

Note: Excessive quantities of oil that enter the induction system of the engine can rapidly increase the engine speed without control.

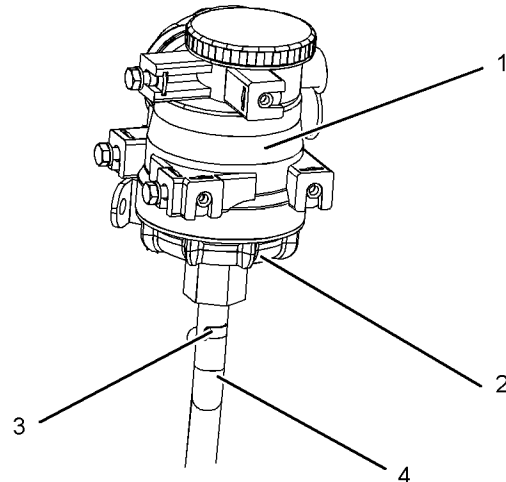

Illustration 51

g03331718

Typical example

1. Ensure that dirt cannot enter the breather assembly. Ensure that the outside body of the breather assembly is clean and free from damage. Place a container under the breather assembly.
 2. Make temporary marks on hose (4) to identify the correct orientation for installation purposes.
- Note:** A one-way valve is installed into the hose, incorrectly installing the hose can cause catastrophic engine failure.
3. Remove clip (3) and remove hose (4) from cap (2). Remove cap (2) from the main body (1).

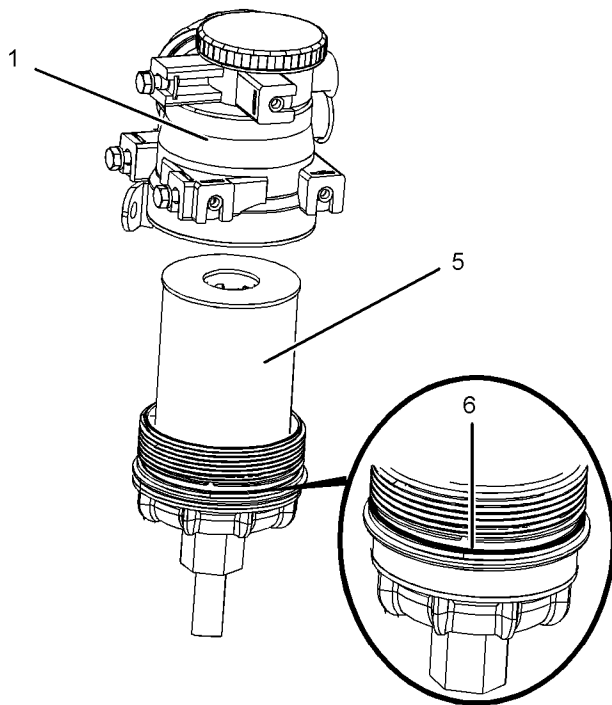

Illustration 52

g03331704

Typical example

4. Remove filter element (5) and remove O ring seal (6) and discard.

Note: Ensure that all parts are clean and free from dirt and damage.

5. Apply clean engine oil to new O-ring seal (6). Install the O-ring seal onto cap (2).
6. Install a new filter element (5) into cap (2).
7. Install cap assembly into the main body (1). Tighten the cap assembly to 10 N·m (7 lb ft).

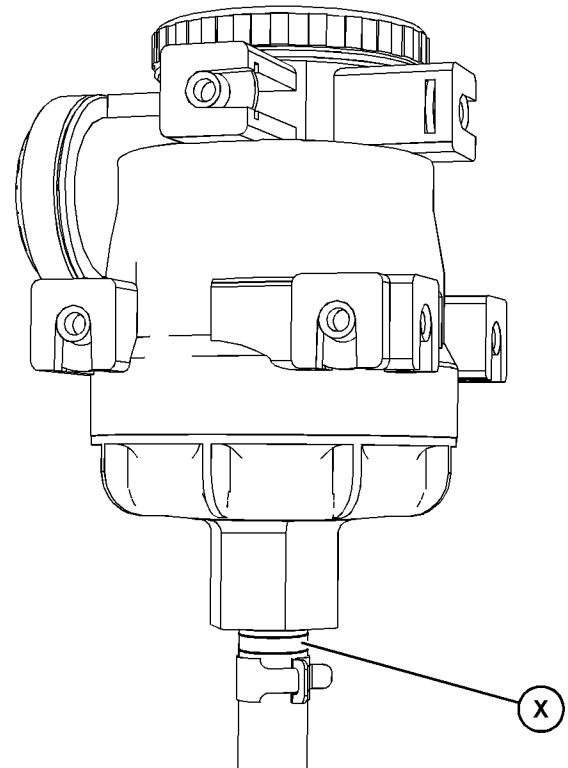

Illustration 53

g06477300

8. Install hose (4) and clip (3). Ensure that the hose is correctly orientated.

If a new hose is being installed, the end of the hose with the white band in Position (X) must be attached to the breather canister. Refer to Illustration 53 for the correct positioning.

Note: Incorrectly installing the hose can cause catastrophic engine failure.

9. Remove the container and clean away any split fluid.

i05153374

Diesel Particulate Filter - Clean

WARNING

Wear goggles, gloves, protective clothing, and a National Institute for Occupational Safety and Health (NIOSH) approved P95 or N95 half-face respirator when handling a used Diesel Particulate Filter or Catalytic Converter Muffler. Failure to do so could result in personal injury.

⚠ WARNING

The muffler, catalytic converter/muffler, and diesel particulate filter will become extremely hot during engine operation. A hot muffler, catalytic converter/muffler and diesel particulate filter can cause serious burns. Allow adequate cooling time before working on or near the muffler, catalytic converter/muffler and diesel particulate filter.

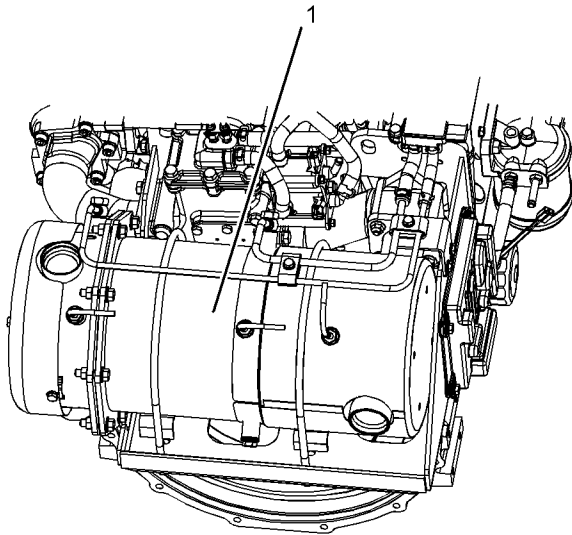

Illustration 54

g02335296

Typical example

Note: Improper cleaning or repair of the Diesel Particulate Filter (DPF) can damage the DPF and the engine aftertreatment system. Contact your Perkins dealer for more information.

The DPF is enclosed within the assembly (1). For information on removal of the DPF, refer to Disassembly and Assembly, "DPF - Remove".

- The DPF on the three cylinder engine is different from the four cylinder engine.
- Only ultra low sulfur diesel fuel can be used in an application that has an aftertreatment regeneration device. The use of other fuel will damage your engine system.
- The engine must be operated on CJ-4 specification of engine oil.

Engine - Clean

i07819515

⚠ WARNING

Personal injury or death can result from high voltage.

Moisture can create paths of electrical conductivity.

Make sure that the electrical system is OFF. Lock out the starting controls and tag the controls "DO NOT OPERATE" .

NOTICE

Accumulated grease and oil on an engine is a fire hazard. Keep the engine clean. Remove debris and fluid spills whenever a significant quantity accumulates on the engine.

Periodic cleaning of the engine is recommended. Steam cleaning the engine will remove accumulated oil and grease. A clean engine provides the following benefits:

- Easy detection of fluid leaks
- Maximum heat transfer characteristics
- Ease of maintenance

Note: Caution must be used to prevent electrical components from being damaged by excessive water when the engine is cleaned. Pressure washers and steam cleaners should not be directed at any electrical connectors or the junction of cables into the rear of the connectors. Avoid electrical components such as the alternator, the starter, and the ECM. Protect the fuel injection pump from fluids to wash the engine.

Ensure that care is taken that the safety labels, emission label, and all other information labels are not removed during engine cleaning.

Aftertreatment

During the engine cleaning process, ensure that water or cleaning fluids cannot enter the aftertreatment system. If cleaning fluids enters the aftertreatment system, damage could occur.

i05160996

Engine Air Cleaner Element - Replace

The air cleaner may be installed by the Original Equipment Manufacture (OEM). Refer to the OEM for instruction on how to remove the element within the air cleaner.

i02335405

Engine Air Cleaner Service Indicator - Inspect

Some engines may be equipped with a different service indicator.

Some engines are equipped with a differential gauge for inlet air pressure. The differential gauge for inlet air pressure displays the difference in the pressure that is measured before the air cleaner element and the pressure that is measured after the air cleaner element. As the air cleaner element becomes dirty, the pressure differential rises. If your engine is equipped with a different type of service indicator, follow the OEM recommendations in order to service the air cleaner service indicator.

The service indicator may be mounted on the air cleaner element or in a remote location.

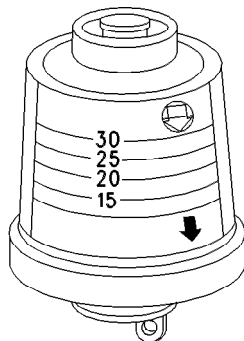

Illustration 55

g00103777

Typical service indicator

Observe the service indicator. The air cleaner element should be cleaned or the air cleaner element should be replaced when one of the following conditions occur:

- The yellow diaphragm enters the red zone.
- The red piston locks in the visible position.

Test the Service Indicator

Service indicators are important instruments.

- Check for ease of resetting. The service indicator should reset in less than three pushes.
- Check the movement of the yellow core when the engine is accelerated to the engine rated speed. The yellow core should latch at the greatest vacuum that is attained.

If the service indicator does not reset easily, or if the yellow core does not latch at the greatest vacuum, the service indicator should be replaced. If the new service indicator will not reset, the hole for the service indicator may be restricted.

The service indicator may need to be replaced frequently in environments that are severely dusty.

i07819526

Engine Air Precleaner - Check/Clean

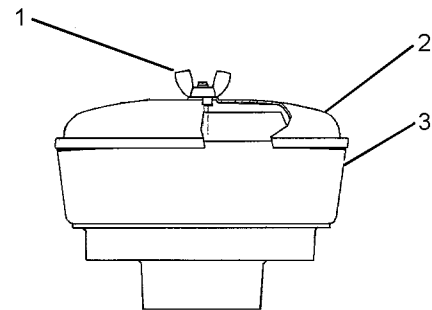

Illustration 56

g01453058

Typical engine air precleaner

- (1) Wing nut
- (2) Cover
- (3) Body

Remove wing nut (1) and cover (2). Check for an accumulation of dirt and debris in body (3). Clean the body, if necessary.

After cleaning the precleaner, install cover (2) and wing nut (1).

Note: When the engine is operated in dusty conditions, more frequent cleaning is required.

Do not tap or strike the air cleaner element.

i07819538

Engine Mounts - Inspect

Note: The engine mounts may not have been supplied by Perkins. Refer to the Original Equipment Manufacturer (OEM) information for further details on the engine mounts and the correct bolt torque.

Inspect the engine mounts for deterioration and for correct bolt torque. Excessive engine vibration can be caused by the following conditions:

- Incorrect mounting of the engine
- Deterioration of the engine mounts
- Loose engine mounts

Any engine mount that shows deterioration should be replaced. Refer to the OEM information for the recommended torques.

When the engine mounts are supplied by Perkins the maintenance procedure will be supplied in the Disassembly and Assembly manual for your engine.

i05164949

Engine Oil Level - Check

WARNING

Hot oil and hot components can cause personal injury. Do not allow hot oil or hot components to contact the skin.

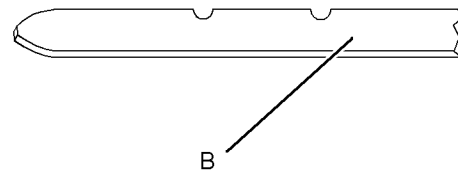
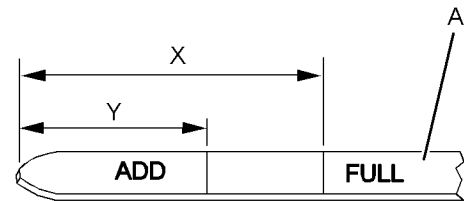

Illustration 57

g03317856

(Y) "ADD" mark. (X) "FULL" mark.

(A) Original oil level gauge
(B) Alternative oil level gauge

NOTICE

Perform this maintenance with the engine stopped.

Note: Oil gauge (A) or oil gauge (B) may be installed in the engine.

1. Maintain the oil level between "ADD" mark (Y) and "FULL" mark (X) on oil level gauge (1). Do not fill the crankcase above "FULL" mark (X).

NOTICE

Operating your engine when the oil level is above the "FULL" mark could cause your crankshaft to dip into the oil. The air bubbles created from the crankshaft dipping into the oil reduces the oil's lubricating characteristics and could result in the loss of power.

2. Remove the oil filler cap and add oil, if necessary. Clean the oil filler cap. Install the oil filler cap.

i05153469

Engine Oil and Filter - Change

WARNING

Hot oil and hot components can cause personal injury. Do not allow hot oil or hot components to contact the skin.

NOTICE

Care must be taken to ensure that fluids are contained during performance of inspection, maintenance, testing, adjusting and repair of the product. Be prepared to collect the fluid with suitable containers before opening any compartment or disassembling any component containing fluids.

Dispose of all fluids according to local regulations and mandates.

NOTICE

Keep all parts clean from contaminants.

Contaminants may cause rapid wear and shortened component life.

Do not drain the oil when the engine is cold. As the oil cools, suspended waste particles settle on the bottom of the oil pan. The waste particles are not removed with the draining cold oil. Drain the crankcase with the engine stopped. Drain the crankcase with the oil warm. This draining method allows the waste particles that are suspended in the oil to be drained correctly.

Failure to follow this recommended procedure will cause the waste particles to be recirculated through the engine lubrication system with the new oil.

Drain the Engine Oil

After the engine has been run at the normal operating temperature, stop the engine. Use one of the following methods to drain the engine crankcase oil:

- If the engine is equipped with a drain valve, turn the drain valve knob counterclockwise in order to drain the oil. After the oil has drained, turn the drain valve knob clockwise in order to close the drain valve.
- If the engine is not equipped with a drain valve, remove the oil drain plug in order to allow the oil to drain. After the oil has drained, the oil drain plug should be cleaned and installed.

Replace the Oil Filter

NOTICE

Perkins oil filters are built to Perkins specifications. Use of an oil filter not recommended by Perkins could result in severe engine damage to the engine bearings, crankshaft, etc., as a result of the larger waste particles from unfiltered oil entering the engine lubricating system. Only use oil filters recommended by Perkins.

1. Remove the oil filter with a suitable tool.

Note: The following actions can be carried out as part of the preventive maintenance program.

2. Cut the oil filter open with a suitable tool. Break apart the pleats and inspect the oil filter for metal debris. An excessive amount of metal debris in the oil filter may indicate early wear or a pending failure.

Use a magnet to differentiate between the ferrous metals and the nonferrous metals that are found in the oil filter element. Ferrous metals may indicate wear on the steel and cast iron parts of the engine.

Nonferrous metals may indicate wear on the aluminum parts, brass parts, or bronze parts of the engine. Parts that may be affected include the following items: main bearings, rod bearings, turbocharger bearings and cylinder heads.

Due to normal wear and friction, it is not uncommon to find small amounts of debris in the oil filter. Consult your Perkins dealer or your Perkins distributor in order to arrange for a further analysis if an excessive amount of debris is found in the oil filter.

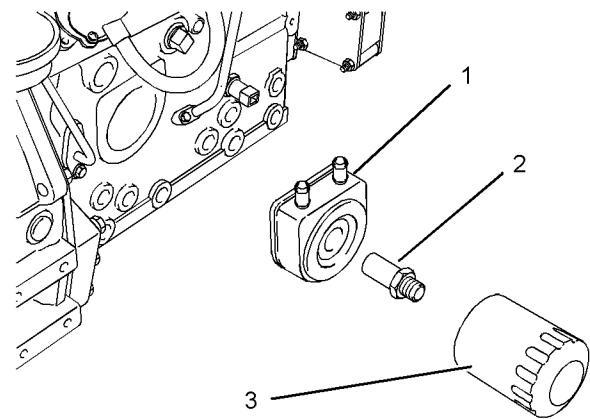

Illustration 58

g01334593

- (1) Oil cooler
- (2) Adapter
- (3) Oil filter

Note: The oil cooler (1) and the adapter (2) are installed on engines that have a turbocharger.

3. Clean the sealing surface of the cylinder block or the oil cooler (1).
4. Apply clean engine oil to the new oil filter seal (3).

NOTICE

Do not fill the oil filters with oil before installing them. This oil would not be filtered and could be contaminated. Contaminated oil can cause accelerated wear to engine components.

5. Install the oil filter. Tighten the oil filter by hand. Do not overtighten the oil filter.

Fill the Engine Crankcase

1. Remove the oil filler cap. Refer to the Operation and Maintenance Manual for more information on lubricant specifications. Fill the crankcase with the correct amount of oil. Refer to the Operation and Maintenance Manual for more information on refill capacities.

NOTICE

If equipped with an auxiliary oil filter system or a remote oil filter system, follow the OEM or filter manufacturer's recommendations. Under filling or overfilling the crankcase with oil can cause engine damage.

NOTICE

To prevent crankshaft bearing damage, crank the engine with the fuel OFF. This will fill the oil filters before starting the engine. Do not crank the engine for more than 30 seconds.

2. Start the engine and run the engine at "LOW IDLE" for 2 minutes. Perform this procedure in order to ensure that the lubrication system has oil and that the oil filters are filled. Inspect the oil filter for oil leaks.
3. Stop the engine and allow the oil to drain back to the sump for a minimum of 10 minutes.

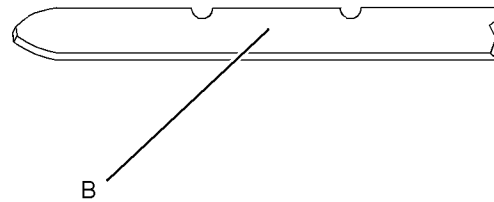
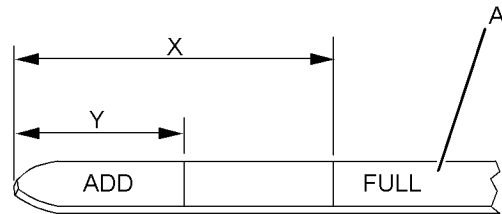

Illustration 59

g03306420

(Y) "ADD" mark. (X) "FULL" mark.

(A) Original oil level gauge

(B) Alternative oil level gauge

4. Remove the oil level gauge in order to check the oil level. Maintain the oil level between the "MIN" and "MAX" marks on the oil level gauge.

i05153520

Engine Valve Lash - Check

This maintenance is recommended by Perkins as part of a lubrication and preventive maintenance schedule in order to help provide maximum engine life. The maintenance for the valve lash is important in order to keep the engine compliant.

NOTICE

Only qualified service personnel should perform this maintenance. Refer to the Service Manual or your authorized Perkins dealer or your Perkins distributor for the complete valve lash adjustment procedure.

Operation of Perkins engines with incorrect valve lash can reduce engine efficiency, and also reduce engine component life.

⚠ WARNING

Ensure that the engine can not be started while this maintenance is being performed. To help prevent possible injury, do not use the starting motor to turn the flywheel.

Hot engine components can cause burns. Allow additional time for the engine to cool before measuring/adjusting valve lash clearance.

Ensure that the engine is stopped before measuring the valve lash. The engine valve lash can be inspected and adjusted when the temperature of the engine is hot or cold.

Refer to Systems Operation, Testing and Adjusting, "Engine Valve Lash - Inspect/Adjust" for more information.

i07942206

Fan Clearance - Check (Industrial Engine)

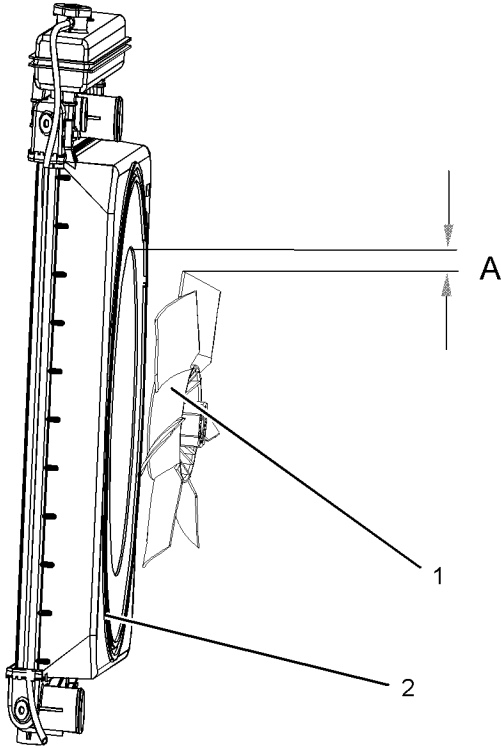

Illustration 60

g03309719

Typical example

Ensure that the engine is stopped. Ensure that the battery disconnect switch is in the OFF position. Ensure that the cooling system is full.

The clearance between the cover (2) and the fan (1) will require checking. The gap between the edge of the cover and the tip of the fan blade (A) must be checked in four equally spaced positions. The fan blade should be as central as possible in the cover.

The minimum fan tip clearance is 2 mm (0.07874 inch). If it is not possible to achieve the minimum fan tip clearance, inspect the radiator mounts. Refer to this Operation and Maintenance Manual, "Engine Mounts - Inspect" for further information.

i05161054

Fuel Filter (In-Line) - Replace

⚠ WARNING

Fuel leaked or spilled onto hot surfaces or electrical components can cause a fire. To help prevent possible injury, turn the start switch off when changing fuel filters or water separator elements. Clean up fuel spills immediately.

Note: Refer to Systems Operation, Testing, and Adjusting, "Cleanliness of Fuel System Components" for detailed information on the standards of cleanliness that must be observed during ALL work on the fuel system.

NOTICE

Ensure that the engine is stopped before any servicing or repair is performed.

The location of the in-line fuel filter will depend on the application that the engine has been installed.

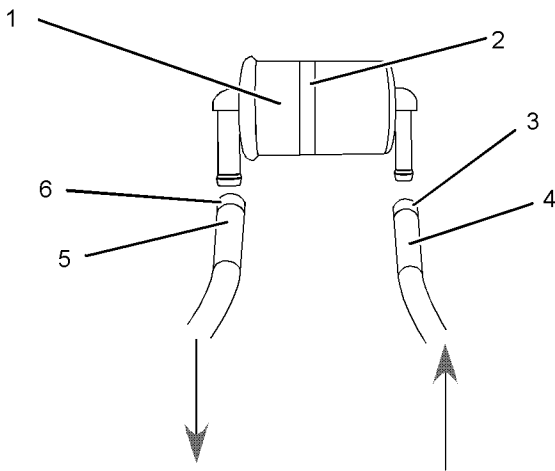

Illustration 61

g03315616

Arrows show fuel flow

Note: The in-line fuel filter is an off engine part.

1. Turn the fuel supply valve (if equipped) to the OFF position. Remove clamp (3) and remove clamp (6).
2. Remove inlet hose (4) and remove outlet hose (5) from in-line filter (1).
3. If installed, remove clamp (2) and remove in-line filter (1) from application.
4. Install new in-line filter (1) and install clamp (2).
5. Install inlet hose (4) and install clamp (3). Install outlet hose (5) and install clamp (6).
6. Turn the fuel supply valve (if equipped) to the ON position. Prime the system, refer to this Operation and Maintenance Manual, "Fuel System - Prime".

i02154268

Fuel Injector - Test/Change

⚠ WARNING

Fuel leaked or spilled onto hot surfaces or electrical components can cause a fire.

⚠ WARNING

Make sure that you wear eye protection at all times during testing. When fuel injection nozzles are tested, test fluids travel through the orifices of the nozzle tip with high pressure. Under this amount of pressure, the test fluid can pierce the skin and cause serious injury to the operator. Always keep the tip of the fuel injection nozzle pointed away from the operator and into the fuel collector and extension.

NOTICE

Do not allow dirt to enter the fuel system. Thoroughly clean the area around a fuel system component that will be disconnected. Fit a suitable cover over disconnected fuel system component.

Regular maintenance of the fuel injectors is recommended by Perkins. The fuel injectors must be removed and tested by an authorized agent. The fuel injectors should not be cleaned as cleaning with incorrect tools can damage the nozzle. The fuel injectors should be renewed only if a fault with the fuel injectors occurs. Some of the problems that may indicate that new fuel injectors are needed are listed below:

- The engine will not start or the engine is difficult to start.
- Not enough power
- The engine misfires or the engine runs erratically.
- High fuel consumption
- Black exhaust smoke
- The engine knocks or there is vibration in the engine.
- Excessive engine temperature

For further information on the removal and the installation of the fuel injectors, refer to the Disassembly and Assembly manual.

For further information on the testing of fuel injectors, refer to the Testing and Adjusting manual.

Identification of a suspect Fuel Injector

⚠ WARNING

Work carefully around an engine that is running. Engine parts that are hot, or parts that are moving, can cause personal injury.

NOTICE

If your skin comes into contact with high pressure fuel, obtain medical assistance immediately.

NOTICE

If a fuel injector is suspected of operating outside of normal parameters it should be removed by a qualified technician. The suspect fuel injector should be taken to an authorised agent for inspection.

Operate the engine at a fast idle speed in order to identify the faulty fuel injector. Individually loosen and tighten the union nut for the high pressure pipe to each fuel injector. Do not loosen the union nut more than half a turn. There will be little effect on the engine speed when the union nut to the faulty fuel injector is loosened.

Consult your authorized Perkins dealer or your Perkins distributor for further assistance.

i08193365

Fuel System - Prime

NOTICE

Care must be taken to ensure that fluids are contained during performance of inspection, maintenance, testing, adjusting and repair of the product. Be prepared to collect the fluid with suitable containers before opening any compartment or disassembling any component containing fluids.

Dispose of all fluids according to local regulations and mandates.

Use the following procedure to prime the fuel system:

If air enters the fuel system, the air must be purged from the fuel system before the engine can be started. Air can enter the fuel system when the following events occur:

- The fuel tank is empty or the fuel tank has been partially drained.
- The low-pressure fuel lines are disconnected.
- A leak exists in the low-pressure fuel system.
- The fuel filter is replaced.

Mechanical Priming Pump

Primary Filter

Ensure that the air is removed from the primary filter before you prime the secondary fuel filter. Refer to illustration 62 .

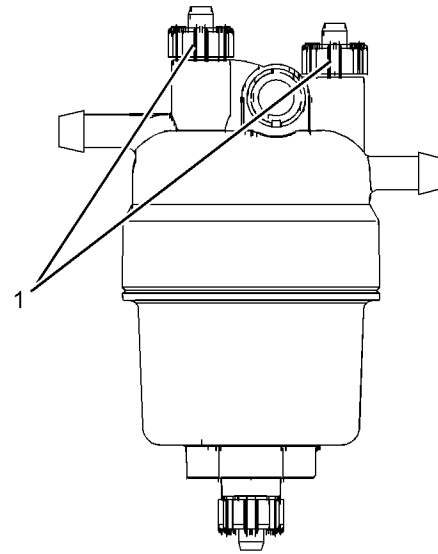

Illustration 62

g01316878

This filter may not be installed on the engine.

(1) Vent screws

Priming the Primary Fuel Filter

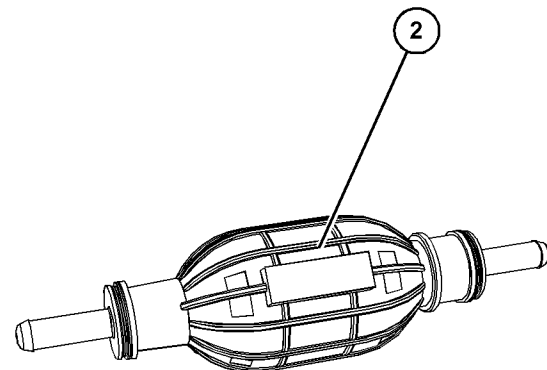

Illustration 63

g06221845

1. If equipped, operate the hand priming pump (2) until fuel free from air comes from the vent screw (1). Then close vent screw (1) by hand.

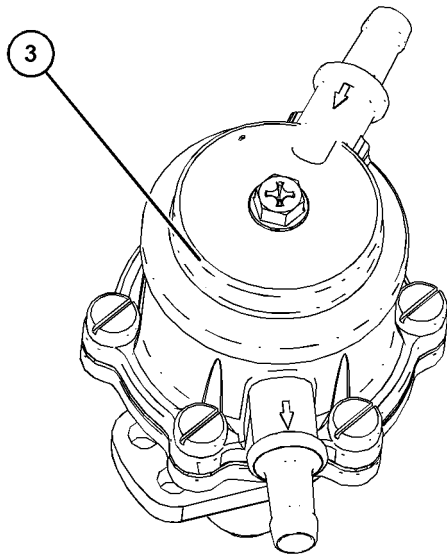

Illustration 64

g06221885

2. If the hand priming pump is not installed, operate the starting motor to crank the engine. Crank the engine to operate the transfer pump (3). Do not operate the transfer pump for more than 15 seconds. After 15 seconds, stop and wait 30 seconds before operating the starting motor.
3. When fuel free from air comes from the vent screw (1) close vent screw (1) by hand.

Secondary Fuel filters

There are three types of fuel filter that may be installed on the engine.

- Element
- Canister
- Spin-on filter with fuel priming pump

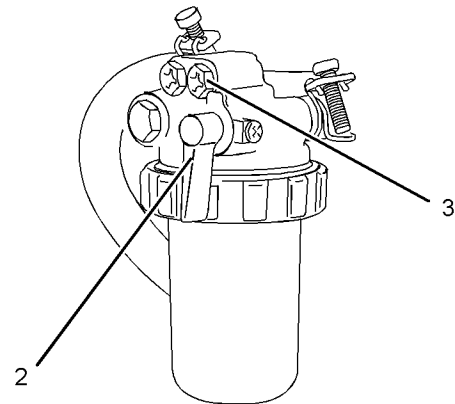

Illustration 65

g01327360

Element

- (2) Fuel valve
- (3) Vent screw

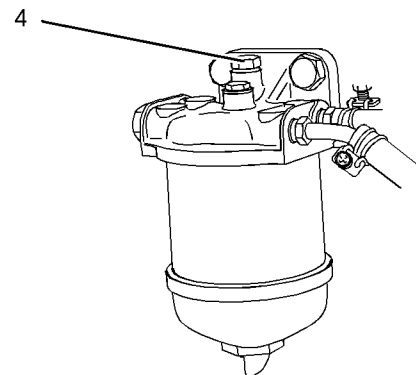

Illustration 66

g01327361

Canister

- (4) Vent screw

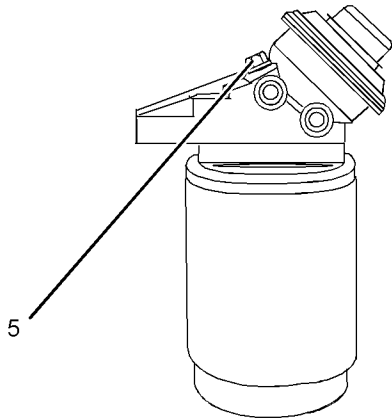

Illustration 67

g01327363

Spin-on filter with fuel priming pump

(5) Vent screw

Vent screw (3) is installed on the filter that has an element. Vent screw (4) is installed on the fuel filter that has a canister. Vent screw (5) is installed on the spin-on filter.

Priming the system

Note: Some fuel system will use gravity to prime the primary fuel filter. When gravity is used to deliver the fuel, ensure that the fuel tank is full and that all stop valves in the fuel line are open.

There are four different types of systems that can be installed on the engine to prime the fuel system. Refer to illustration 68 .

- Hand priming pump
- In-line hand priming pump
- Electrical priming pump
- Transfer pump that is operated by the starting motor

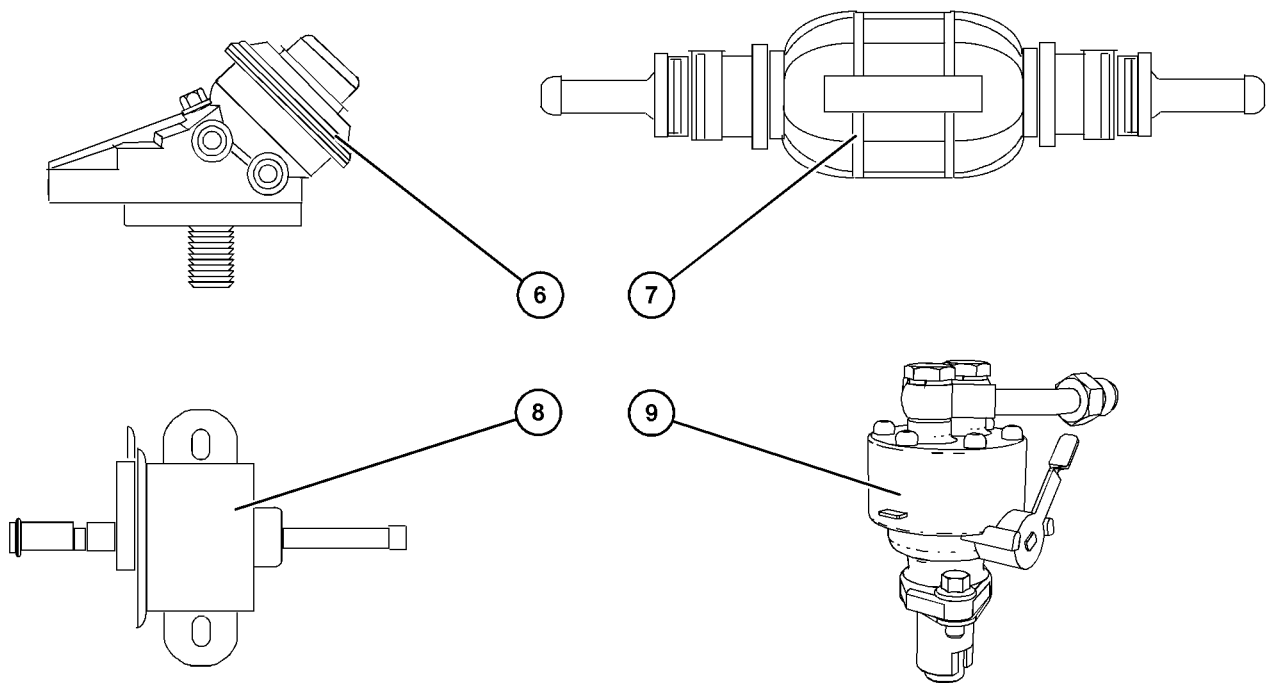

Illustration 68

g06523817

(6) Hand priming pump
(7) In-line priming pump

(8) Electrical priming pump
(9) Fuel transfer pump with hand priming

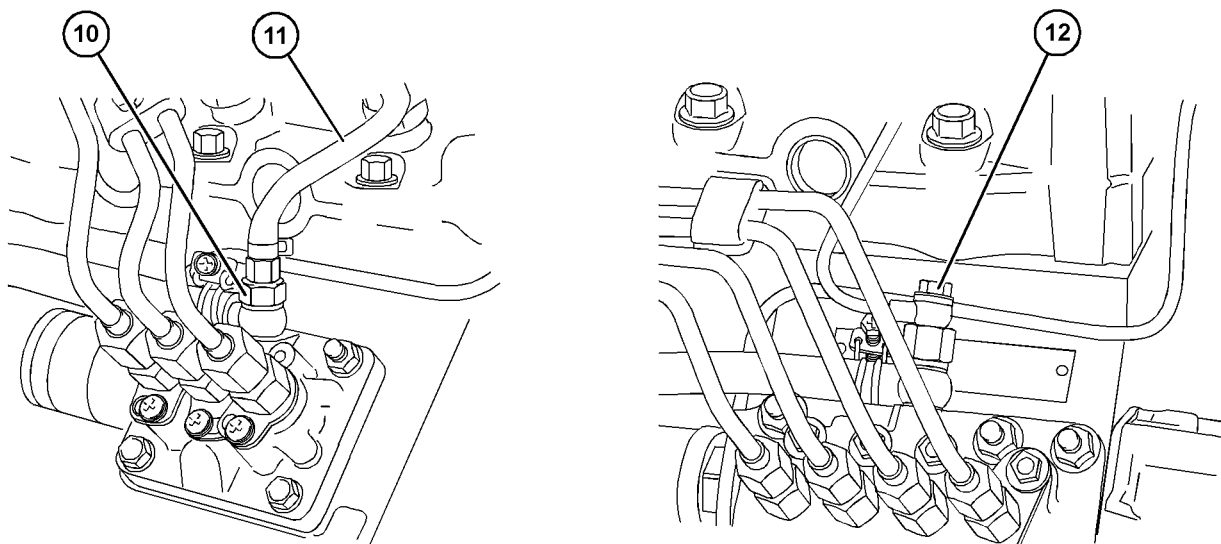

Illustration 69

g06523835

(10) Connector bolt

(11) Fuel return line

(12) Connector bolt

Hand Priming Pump 6

To identify the hand priming pump, refer to illustration 68 .

1. Ensure that fuel valve (2) for the fuel filter that has an element is in the ON position. Refer to illustration 65 .

2. Loosen vent screw (3, 4 or 5) on the fuel filter.
3. Operate hand priming pump (6). When fuel free from air flows from the vent screw tighten the vent screw.
4. Loosen connection (10 or 12) at the fuel injection pump. Refer to illustration 69 .

Note: Fuel return line (11) may need to be removed to prime the fuel system.

5. Operate the hand priming pump. When fuel free from air flows from the connections tighten the connecting bolt.
6. The engine should now be able to start. Operate the starting motor to start the engine.

Note: Do not operate the starting motor for more than 15 seconds. If the engine does not start after 15 seconds, stop and wait for 30 seconds before trying again.

In-line Priming Pump 7

To identify the in-line priming pump, refer to illustration 68 .

1. Ensure that fuel valve (2) for the fuel filter that has an element is in the ON position. Refer to illustration 65 .
2. Loosen vent screw (3, 4 or 5) on the fuel filter.
3. Operate in-line priming pump (7). When fuel free from air flows from the vent screw tighten the vent screw.
4. Loosen connection (10 or 12) at the fuel injection pump. Refer to illustration 69 .

Note: Fuel return line (11) may need to be removed to prime the fuel system.

5. Operate the in-line priming pump. When fuel free from air flows from the connections tighten the connecting bolt.
6. The engine should now be able to start. Operate the starting motor to start the engine.

Note: Do not operate the starting motor for more than 15 seconds. If the engine does not start after 15 seconds, stop and wait for 30 seconds before trying again.

Electrical Priming Pump 8

To identify the electrical priming pump, refer to illustration 68 .

Turn the keyswitch to the ON position for 2 minutes to prime the fuel system. Turn keyswitch to OFF position, then turn on again. The engine is primed and ready to start.

If the engine fails to start, follow Step (1) through Step (6).

1. Ensure that fuel valve (2) for the fuel filter that has an element is in the ON position. Refer to illustration 65 .
2. Loosen vent screw (3, 4 or 5) on the fuel filter.
3. Operate electrical priming pump (8). When fuel free from air flows from the vent screw tighten the vent screw. Switch off the electrical priming pump.
4. Loosen connector bolt (10 or 12) at the fuel injection pump. Refer to illustration 69 .

Note: Fuel return line (11) may need to be removed to prime the fuel system.

5. Operate the electrical priming pump (8). When fuel free from air flows from the connections tighten the connector bolt. If removed, install fuel return line (11).
6. The engine should now be able to start. Operate the starting motor to start the engine.

Note: Do not operate the starting motor for more than 15 seconds. If the engine does not start after 15 seconds, stop and wait for 30 seconds before trying again.

Fuel Transfer Pump 9

To identify the fuel transfer pump, refer to illustration 68 .

Note: If the transfer pump is not equipped with a manual priming lever and the engine is not equipped with any other priming option, you must operate the starting motor to prime the fuel system. Do not operate the starting motor for more than 15 seconds continuously. After 15 seconds, stop and wait for 30 seconds before operating the starting motor again.

1. Ensure that fuel valve (2) for the fuel filter that has an element is in the ON position. Refer to illustration 65 .
2. Loosen vent screw (3, 4 or 5) on the fuel filter.
3. Operate fuel transfer pump (9). When fuel free from air flows from the vent screw tighten the vent screw. Stop the fuel transfer pump.
4. Loosen connection (10 or 12) at the fuel injection pump. Refer to illustration 69 .

Note: Fuel return line (11) may need to be removed to prime the fuel system.

5. Operate the fuel transfer pump. When fuel free from air flows from the connections tighten the connecting bolt. Stop the transfer pump.
6. The engine should now be able to start. Operate the starting motor to start the engine.

Note: Do not operate the starting motor for more than 15 seconds. If the engine does not start after 15 seconds, stop and wait for 30 seconds before trying again.

i05164991

Fuel System Secondary Filter - Replace

WARNING

Fuel leaked or spilled onto hot surfaces or electrical components can cause a fire. To help prevent possible injury, turn the start switch off when changing fuel filters or water separator elements. Clean up fuel spills immediately.

NOTICE

Do not allow dirt to enter the fuel system. Thoroughly clean the area around a fuel system component that will be disconnected. Fit a suitable cover over disconnected fuel system component.

NOTICE

Care must be taken to ensure that fluids are contained during performance of inspection, maintenance, testing, adjusting and repair of the product. Be prepared to collect the fluid with suitable containers before opening any compartment or disassembling any component containing fluids.

Dispose of all fluids according to local regulations and mandates.

Fuel Filter with Canister

1. Close the fuel supply valve.

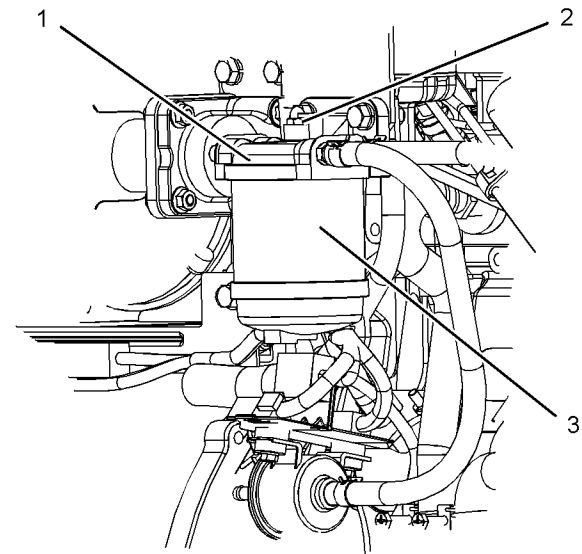

Illustration 70

g03317866

Typical example

2. Clean the outside of the fuel filter assembly (1).
3. Remove setscrew (2).
4. Remove the canister (3). Ensure that any fluid is drained into a suitable container.

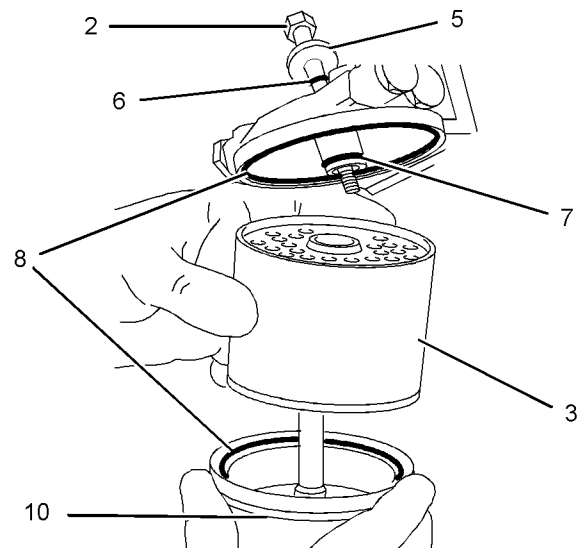

Illustration 71

g02710378

Typical example

5. Assemble the following items: seals (8), seal (7), canister (3) and bowl (10). Place washer (5) and seal (6) on setscrew (2).

6. Fasten the assembly to the fuel filter base with setscrew (2).

The fuel system will need to be primed after the new filter is installed. Refer to this Operation and Maintenance Manual, "Fuel System - Prime".

i02335436

Fuel Tank Water and Sediment - Drain

NOTICE

Care must be taken to ensure that fluids are contained during performance of inspection, maintenance, testing, adjusting and repair of the product. Be prepared to collect the fluid with suitable containers before opening any compartment or disassembling any component containing fluids.

Dispose of all fluids according to local regulations and mandates.

Fuel Tank

Fuel quality is critical to the performance and to the service life of the engine. Water in the fuel can cause excessive wear to the fuel system.

Water can be introduced into the fuel tank when the fuel tank is being filled.

Condensation occurs during the heating and cooling of fuel. The condensation occurs as the fuel passes through the fuel system and the fuel returns to the fuel tank. This causes water to accumulate in fuel tanks. Draining the fuel tank regularly and obtaining fuel from reliable sources can help to eliminate water in the fuel.

Drain the Water and the Sediment

Fuel tanks should contain some provision for draining water and draining sediment from the bottom of the fuel tanks.

Open the drain valve on the bottom of the fuel tank in order to drain the water and the sediment. Close the drain valve.

Check the fuel daily. Allow five minutes after the fuel tank has been filled before draining water and sediment from the fuel tank.

Fill the fuel tank after operating the engine in order to drive out moist air. This will help prevent condensation. Do not fill the tank to the top. The fuel expands as the fuel gets warm. The tank may overflow.

Some fuel tanks use supply pipes that allow water and sediment to settle below the end of the fuel supply pipe. Some fuel tanks use supply lines that take fuel directly from the bottom of the tank. If the engine is equipped with this system, regular maintenance of the fuel system filter is important.

Fuel Storage Tanks

Drain the water and the sediment from the fuel storage tank at the following intervals:

- Weekly
- Service intervals
- Refill of the tank

This will help prevent water or sediment from being pumped from the storage tank into the engine fuel tank.

If a bulk storage tank has been refilled or moved recently, allow adequate time for the sediment to settle before filling the engine fuel tank. Internal baffles in the bulk storage tank will also help trap sediment. Filtering fuel that is pumped from the storage tank helps to ensure the quality of the fuel. When possible, water separators should be used.

i06792012

Glow Plugs (ARD Combustion) - Replace

Ensure that all adjustments and repairs are performed by authorized personnel that have the correct training.

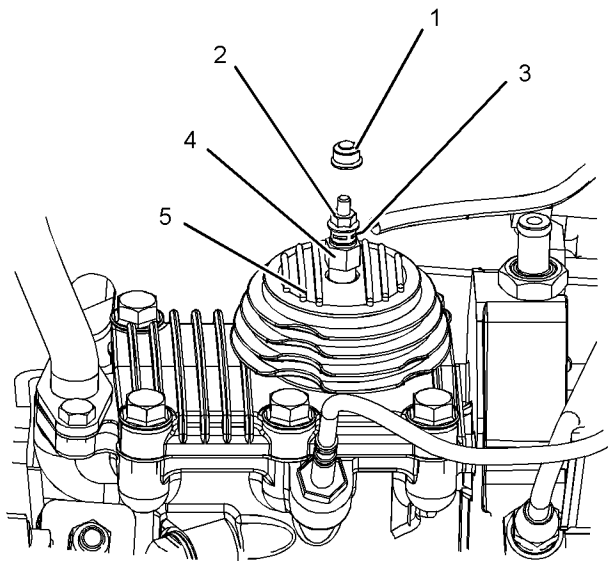

Illustration 72

g03310158

Typical example

Remove the Glow Plug for the After Regeneration Device (ARD)

1. Ensure that all components are clean and free from dirt and grease. Remove protective cap (1).
2. Remove nut (2) from glow plug (4) and remove electrical connection (3).
3. Remove glow plug (4) from ARD (5).

Install New Glow Plug

1. Install new glow plug (4) into ARD (5) and tighten glow plug to a torque of 23 N·m (204 lb in).
2. Install the electrical connection (3) and install nut (2). Tighten nut (2) to a torque of 1.5 N·m (13 lb in).
3. Install protective cap (1).

i02813964

Hoses and Clamps - Inspect/Replace

Inspect all hoses for leaks that are caused by the following conditions:

- Cracking
- Softness

- Loose clamps

Replace hoses that are cracked or soft. Tighten any loose clamps.

NOTICE

Do not bend or strike high pressure lines. Do not install bent or damaged lines, tubes or hoses. Repair any loose or damaged fuel and oil lines, tubes and hoses. Leaks can cause fires. Inspect all lines, tubes and hoses carefully. Tighten all connections to the recommended torque. Do not clip any other item to the high pressure lines.

Check for the following conditions:

- End fittings that are damaged or leaking
- Outer covering that is chafed or cut
- Exposed wire that is used for reinforcement
- Outer covering that is ballooning locally
- Flexible part of the hose that is kinked or crushed
- Armoring that is embedded in the outer covering

A constant torque hose clamp can be used in place of any standard hose clamp. Ensure that the constant torque hose clamp is the same size as the standard clamp.

Due to extreme temperature changes, the hose will harden. Hardening of the hoses will cause hose clamps to loosen. This can result in leaks. A constant torque hose clamp will help to prevent loose hose clamps.

Each installation application can be different. The differences depend on the following factors:

- Type of hose
- Type of fitting material
- Anticipated expansion and contraction of the hose
- Anticipated expansion and contraction of the fittings

Replace the Hoses and the Clamps

Refer to the OEM information for further information on removing and replacing fuel hoses (if equipped).

The coolant system and the hoses for the coolant system are not usually supplied by Perkins. The following text describes a typical method of replacing coolant hoses. Refer to the OEM information for further information on the coolant system and the hoses for the coolant system.

⚠ WARNING

Pressurized System: Hot coolant can cause serious burns. To open the cooling system filler cap, stop the engine and wait until the cooling system components are cool. Loosen the cooling system pressure cap slowly in order to relieve the pressure.

1. Stop the engine. Allow the engine to cool.
2. Loosen the cooling system filler cap slowly in order to relieve any pressure. Remove the cooling system filler cap.

Note: Drain the coolant into a suitable, clean container. The coolant can be reused.

3. Drain the coolant from the cooling system to a level that is below the hose that is being replaced.
4. Remove the hose clamps.
5. Disconnect the old hose.
6. Replace the old hose with a new hose.
7. Install the hose clamps with a torque wrench.

Note: For the correct coolant, see this Operation and Maintenance Manual, "Fluid Recommendations".

8. Refill the cooling system. Refer to the OEM information for further information on refilling the cooling system.
9. Clean the cooling system filler cap. Inspect the cooling system filler cap's seals. Replace the cooling system filler cap if the seals are damaged. Install the cooling system filler cap.
10. Start the engine. Inspect the cooling system for leaks.

i02335774

Radiator - Clean

The radiator is not usually supplied by Perkins. The following text describes a typical cleaning procedure for the radiator. Refer to the OEM information for further information on cleaning the radiator.

Note: Adjust the frequency of cleaning according to the effects of the operating environment.

Inspect the radiator for these items: Damaged fins, corrosion, dirt, grease, insects, leaves, oil and other debris. Clean the radiator, if necessary.

⚠ WARNING

Personal injury can result from air pressure.

Personal injury can result without following proper procedure. When using pressure air, wear a protective face shield and protective clothing.

Maximum air pressure at the nozzle must be less than 205 kPa (30 psi) for cleaning purposes.

Pressurized air is the preferred method for removing loose debris. Direct the air in the opposite direction to the fan's air flow. Hold the nozzle approximately 6 mm (0.25 inch) away from the radiator fins. Slowly move the air nozzle in a direction that is parallel with the radiator tube assembly. This will remove debris that is between the tubes.

Pressurized water may also be used for cleaning. The maximum water pressure for cleaning purposes must be less than 275 kPa (40 psi). Use pressurized water in order to soften mud. Clean the core from both sides.

Use a degreaser and steam for removal of oil and grease. Clean both sides of the core. Wash the core with detergent and hot water. Thoroughly rinse the core with clean water.

If the radiator is blocked internally, refer to the OEM Manual for information regarding flushing the cooling system.

After cleaning the radiator, start the engine. Allow the engine to operate at low idle speed for three to five minutes. Accelerate the engine to high idle. This will help in the removal of debris and the drying of the core. Slowly reduce the engine speed to low idle and then stop the engine. Use a light bulb behind the core in order to inspect the core for cleanliness. Repeat the cleaning, if necessary.

Inspect the fins for damage. Bent fins may be opened with a "comb". Inspect these items for good condition: Welds, mounting brackets, air lines, connections, clamps and seals. Make repairs, if necessary.

i03639888

i05157183

Radiator Pressure Cap - Clean/Replace

WARNING

Pressurized System: Hot coolant can cause serious burns. To open the cooling system filler cap, stop the engine and wait until the cooling system components are cool. Loosen the cooling system pressure cap slowly in order to relieve the pressure.

NOTICE

When any servicing or repair of the engine cooling system is performed the procedure must be performed with the engine on level ground. This will allow you to accurately check the coolant level. This will also help in avoiding the risk of introducing an air lock into the coolant system.

1. Stop the engine and allow the engine to cool. Loosen the cooling system filler cap slowly in order to relieve any pressure. Remove the radiator pressure cap.
2. Check coolant level. Refer to Operation and Maintenance Manual, "Cooling System Coolant Level - Check".
3. Install new radiator pressure cap.

i07888480

Starting Motor - Inspect

Perkins recommends a scheduled inspection of the starting motor. If the starting motor fails, the engine may not start in an emergency situation.

Check the starting motor for correct operation. Check the electrical connections and clean the electrical connections. Refer to the Systems Operation, Testing and Adjusting Manual, "Electric Starting System - Test" for more information on the checking procedure and for specifications consult your Perkins dealer or your Perkins distributor for assistance.

Turbocharger - Inspect (If Equipped)

A regular visual inspection of the turbocharger is recommended. Any fumes from the crankcase are filtered through the air inlet system. Therefore, by-products from oil and from combustion can collect in the turbocharger compressor housing. Over time, this buildup can contribute to loss of engine power, increased black smoke and overall loss of engine efficiency.

If the turbocharger fails during engine operation, damage to the turbocharger compressor wheel and/or to the engine may occur. Damage to the turbocharger compressor wheel can cause additional damage to the pistons, the valves, and the cylinder head.

NOTICE

Turbocharger bearing failures can cause large quantities of oil to enter the air intake and exhaust systems. Loss of engine lubricant can result in serious engine damage.

Minor leakage of oil into a turbocharger under extended low idle operation should not cause problems as long as a turbocharger bearing failure has not occurred.

When a turbocharger bearing failure is accompanied by a significant loss of engine performance, do not continue engine operation until the turbocharger is renewed.

A visual inspection of the turbocharger can minimize unscheduled downtime. A visual inspection of the turbocharger can also reduce the chance for potential damage to other engine parts.

Removal and Installation

For options regarding the removal, installation, and replacement, consult your Perkins dealer or your Perkins distributor. Refer to the Disassembly and Assembly Manual, "Turbocharger - Remove and Turbocharger - Install" for further information.

Inspecting

NOTICE

The compressor housing for the turbocharger must not be removed from the turbocharger for cleaning.

The actuator linkage is connected to the compressor housing. If the actuator linkage is moved or disturbed, the engine may not comply with emissions legislation.

1. Remove the pipe from the turbocharger exhaust outlet and remove the air intake pipe to the turbocharger. Visually inspect the piping for the presence of oil. Clean the interior of the pipes in order to prevent dirt from entering during reassembly.
2. Check for the presence of oil. If oil is leaking from the back side of the compressor wheel, there is a possibility of a failed turbocharger oil seal.

The presence of oil may be the result of extended engine operation at low idle. The presence of oil may also be the result of a restriction of the line for the intake air (clogged air filters), which causes the turbocharger to slobber.
3. Inspect the bore of the housing of the turbine outlet for corrosion.
4. Fasten the air intake pipe and the exhaust outlet pipe to the turbocharger housing.

i02177973

Walk-Around Inspection

Inspect the Engine for Leaks and for Loose Connections

A walk-around inspection should only take a few minutes. When the time is taken to perform these checks, costly repairs and accidents can be avoided.

For maximum engine service life, make a thorough inspection of the engine compartment before starting the engine. Look for items such as oil leaks or coolant leaks, loose bolts, worn belts, loose connections and trash buildup. Make repairs, as needed:

- The guards must be in the correct place. Repair damaged guards or replace missing guards.
- Wipe all caps and plugs before the engine is serviced in order to reduce the chance of system contamination.

NOTICE

For any type of leak (coolant, lube, or fuel) clean up the fluid. If leaking is observed, find the source and correct the leak. If leaking is suspected, check the fluid levels more often than recommended until the leak is found or fixed, or until the suspicion of a leak is proved to be unwarranted.

NOTICE

Accumulated grease and/or oil on an engine is a fire hazard. Remove the accumulated grease and oil. Refer to this Operation and Maintenance Manual, "Engine - Clean" for more information.

- Ensure that the cooling system hoses are correctly clamped and that the cooling system hoses are tight. Check for leaks. Check the condition of all pipes.
- Inspect the water pump for coolant leaks.

Note: The water pump seal is lubricated by the coolant in the cooling system. It is normal for a small amount of leakage to occur as the engine cools down and the parts contract.

Excessive coolant leakage may indicate the need to replace the water pump seal. For the removal of the water pump and the installation of water pump and/or seal, refer to the Disassembly and Assembly Manual, "Water Pump - Remove and Install" for more information or consult your Perkins dealer or your Perkins distributor.

- Inspect the lubrication system for leaks at the front crankshaft seal, the rear crankshaft seal, the oil pan, the oil filters and the rocker cover.
- Inspect the fuel system for leaks. Look for loose fuel line clamps and/or tie-wraps.
- Inspect the piping for the air intake system and the elbows for cracks and for loose clamps. Ensure that hoses and tubes are not contacting other hoses, tubes, wiring harnesses, etc.
- Inspect the alternator belts and any accessory drive belts for cracks, breaks or other damage.

Belts for multiple groove pulleys must be replaced as matched sets. If only one belt is replaced, the belt will carry more load than the belts that are not replaced. The older belts are stretched. The additional load on the new belt could cause the belt to break.

- Drain the water and the sediment from the fuel tank on a daily basis in order to ensure that only clean fuel enters the fuel system.
- Inspect the wiring and the wiring harnesses for loose connections and for worn wires or frayed wires.
- Inspect the ground strap for a good connection and for good condition.
- Disconnect any battery chargers that are not protected against the current drain of the starting motor. Check the condition and the electrolyte level of the batteries, unless the engine is equipped with a maintenance free battery.

- Check the condition of the gauges. Replace any gauges that are cracked. Replace any gauge that can not be calibrated.

i01907756

Water Pump - Inspect

A failed water pump may cause severe engine overheating problems that could result in the following conditions:

- Cracks in the cylinder head
- A piston seizure
- Other potential damage to the engine

Note: The water pump seal is lubricated by the coolant in the cooling system. It is normal for a small amount of leakage to occur as the engine cools down and parts contract.

Visually inspect the water pump for leaks. Renew the water pump seal or the water pump if there is an excessive leakage of coolant. Refer to the Disassembly and Assembly Manual, "Water Pump - Remove and Install" for the disassembly and assembly procedure.

Warranty Section

Warranty Information

i04059789

Federal Emission Control Warranty

Emissions Warranty

The 400F diesel engines are a nonroad compression ignition engine. Perkins Engine Company limited warrants to the initial owner and to the subsequent owner of the 400F diesel engines that such an engine is:

1. Designed, built, and equipped so that the engine conforms, at the time of sale, with all applicable regulations adopted by the United States Environmental Protection Agency (EPA).
2. Free from defects in materials and workmanship in specific emission-related parts for the following period:
 - The warranty period is for 3000 hours or for 5 years, whichever occurs first, after the date of delivery to the owner that operates the engine.

If an emission-related part fails during any of the warranty periods, the part will be repaired or replaced. Any such part repaired or replaced under warranty is warranted for the remainder of the warranty period.

During the term of this warranty, Perkins Engine Company limited will provide through a Perkins distributor or your Perkins dealer or other establishment authorized by it, repair or replacement of any warranted part at no charge to the engine owner.

In an emergency, repairs may be performed at any service establishment, or by the owner, using any replacement part. It is recommended that emission-related parts be replaced with genuine Perkins Engine Company limited parts.

Perkins Engine Company limited will reimburse the owner for their expenses, including diagnostic charges for such an emergency repair. These expenses shall not exceed the Perkins Engine Company limited suggested retail price for all warranted parts replaced, and labor charges based on Perkins Engine Company limited recommended time allowance for the warranty repair and the geographically appropriate hourly labor rate.

As a condition of reimbursement, replaced parts and receipted invoices must be presented at a place of business of a Perkins distributor or your Perkins dealer or other establishment authorized by Perkins Engine Company limited

This warranty covers the following emission-related parts and components:

- Turbocharger System
- Inlet Manifold
- Fuel Injection System
- Crankcase Ventilation System
- Electronic Engine Control System
- Engine Aftertreatment System
- NOx Reduction System
- Aftertreatment Regeneration Device
- Miscellaneous valves, switches, hoses, clamps, connectors, tubing, and sealing devices that are used in the above systems

Limitations and Responsibilities

The warranty is subject to the following conditions:

Perkins Engine Company limited Responsibilities

During the emission warranty period, if a defect in material or workmanship of an emission-related part or component is found, Perkins Engine Company limited will provide the following:

- New, Remanufactured or repaired parts and/or components, approved pursuant to EPA Regulations, required to correct the defect.
- Reasonable and customary labor, during normal working hours that is required to make the warranty repair. Included is the labor in order to remove an engine and install the engine, if necessary.

Note: Items that are replaced under this warranty become the property of Perkins Engine Company limited .

Owner Responsibilities

During the emission warranty period, the owner is responsible for the following items:

- The costs in order to investigate complaints which are not caused by a defect in Perkins Engine Company limited material or Perkins Engine Company limited workmanship.

- Providing timely notice of a warrantable failure and promptly making the product available for repair

Limitations

Perkins Engine Company limited is not responsible for resultant damages to an emission-related part or component resulting from the following items:

- Any application or any installation that Perkins Engine Company limited deems improper.
- Attachments, accessory items, or parts not sold nor approved by Perkins Engine Company limited
- Improper engine maintenance, repair, or abuse.
- Use of improper fuel, lubricants, or fluids.
- Owners unreasonable delay in making the product available after being notified of a potential product problem.

This warranty is in addition to Perkins Engine Company limited standard warranty, applicable to the engine product involved.

Remedies under this warranty are limited to the provision of material and services as specified herein. Perkins Engine Company limited is not responsible for incidental or consequential damages, including but not limited to downtime or loss-of-use of engine.

i04059870

California Emission Control Warranty Statement

Emissions Warranty

The 400F engines are a nonroad compression ignition engine.

The California Air Resources Board (CARB) and Perkins Engines Company Limited are pleased to explain the emission control system warranty on both of these diesel engines.

In California, new motor vehicle engines must be designed, built, and equipped in order to meet the state's stringent anti-smog standards. Perkins Engines Company Limited must warrant the emission control system on your engine for the duration of time listed below provided, there has not been any abuse, neglect or improper maintenance of your engine or your engine aftertreatment system.

Perkins Engines Company Limited warrants to the initial owner and to the subsequent owner of the 400F diesel engines that such an engine is:

1. Designed, built, and equipped so that the engine conforms, at the time of sale, with all applicable regulations adopted by the California Air Resources Board (CARB).
2. Free from defects in materials and workmanship in specific emission-related parts for the following period:
 - The warranty period is for 3000 hours or for 5 years, whichever occurs first, after the date of delivery to the owner that operates the engine.

If an emission-related part fails during any of the warranty periods, the part will be repaired or replaced. Any such part repaired or replaced under warranty is warranted for the remainder of the warranty period.

During the term of this warranty, Perkins Engines Company Limited will provide through a Perkins distributor or your Perkins dealer or other establishment authorized by it, repair or replacement of any warranted part at no charge to the engine owner.

In an emergency, repairs may be performed at any service establishment, or by the owner, using any replacement part. It is recommended that emission-related parts be replaced with genuine Perkins Engines Company Limited parts.

Perkins Engines Company Limited will reimburse the owner for their expenses, including diagnostic charges for such an emergency repair. These expenses shall not exceed the Perkins Engines Company Limited suggested retail price for all warranted parts replaced, and labor charges based on Perkins Engines Company Limited recommended time allowance for the warranty repair and the geographically appropriate hourly labor rate.

As a condition of reimbursement, replaced parts and receipted invoices must be presented at a place of business of a Perkins distributor or your Perkins dealer or other establishment authorized by Perkins Engines Company Limited.

This warranty covers the following emission-related parts and components:

- Turbocharger System
- Inlet Manifold
- Fuel Injection System
- Crankcase Ventilation System

Warranty Section
Emissions Warranty Information

- Electronic Engine Control System
- Engine Aftertreatment System
- NOx Reduction System
- Aftertreatment Regeneration Device
- Miscellaneous valves, switches, hoses, clamps, connectors, tubing, and sealing devices that are used in the above systems

- Improper engine maintenance, repair, or abuse.
- Use of improper fuel, lubricants, or fluids.
- Owners unreasonable delay in making the product available after being notified of a potential product problem.

This warranty is in addition to Perkins Engines Company Limited standard warranty, applicable to the engine product involved.

Remedies under this warranty are limited to the provision of material and services as specified herein. Perkins Engines Company Limited is not responsible for incidental or consequential damages, including but not limited to downtime or loss-of-use of engine.

Limitations and Responsibilities

The warranty is subject to the following conditions:

Perkins Engines Company Limited Responsibilities

During the emission warranty period, if a defect in material or workmanship of an emission-related part or component is found, Perkins Engines Company Limited will provide the following:

- New, Remanufactured or repaired parts and/or components, approved pursuant to (CARB) Regulations, required to correct the defect.
- Reasonable and customary labor, during normal working hours that is required to make the warranty repair. This includes labor in order to remove an engine and install the engine, if necessary.

Note: Items that are replaced under this warranty become the property of Perkins Engines Company Limited .

Owner Responsibilities

During the emission warranty period, the owner is responsible for the following items:

- The costs in order to investigate complaints which are not caused by a defect in Perkins Engines Company Limited material or Perkins Engines Company Limited workmanship.
- Providing timely notice of a warrantable failure and promptly making the product available for repair

Limitations

Perkins Engines Company Limited is not responsible for resultant damages to an emission-related part or component resulting from the following items:

- Any application or any installation that Perkins Engines Company Limited deems improper.
- Attachments, accessory items, or parts not sold nor approved by Perkins Engines Company Limited

i05200893

Emissions Warranty Information

The aftertreatment system can be expected to function properly for the life-time of the engine (emissions durability period) subject to prescribed maintenance requirements being followed.

- EPA _____ United States Environmental Protection Agency
- CARB _____ California Air Resources Board

Note: The warranty of the engine applies to engines that are operated within the areas of the world where the following regulations apply: US EPA Tier 4 Interim, EU Stage IIIB or Japanese MLIT Step 4. If an engine is operated in regions of the world where these regulations do not apply the warranty will be void. Contact your Perkins dealer or your Perkins distributor for more information.

Maintenance Recommendations

Perkins Engines Company Limited engines are certified by the EPA and the CARB in order to comply with exhaust emission standards and gaseous emission standards that are prescribed by the law at the time of manufacture.

Efficiency of the emission control and the engine performance depends on adherence to proper operation and maintenance recommendations and use of recommended fuels and lubricating oils. According to recommendations, major adjustments and repairs should be made by your authorized Perkins distributor or your authorized Perkins dealer.

Various chemical fuel additives which claim to reduce visible smoke are available commercially. Although additives have been used to solve some isolated smoke problems in the field, additives are not recommended for general use. The engines should be certified without smoke depressants according to federal smoke regulations.

Take corrective steps immediately after worn parts which may affect the emissions level are discovered in order to ensure the proper operation of the emission control systems. The use of genuine Perkins components is recommended. If the owner uses non-Perkins components, then the non-Perkins components must not adversely affect the emissions level of the engine.

For information on the use of Aftermarket Products and Perkins Engines, refer to this Operation and Maintenance Manual, "Engine Description".

Regular maintenance intervals with a special emphasis on the following items are necessary in order to keep exhaust emissions within acceptable limits for the useful life of the engine. Refer to the Operation and Maintenance Manual, "Severe Service Application - Check" topic (Maintenance Section). If the engine is operating under severe conditions, adjust the maintenance schedule accordingly. See your authorized Perkins distributor/dealer in order to help analyze your specific application, operating environment, and maintenance schedule adjustments.

The following information is an explanation of maintenance items for emission-related components. See the Operation and Maintenance Manual, "Maintenance Interval Schedule" (Maintenance Section) for the specific interval for the following items.

ENGINE AFTERTREATMENT SYSTEM – The Engine Aftertreatment Systems are sensitive to the type of fuel and lubricants that is used. Also, the engine aftertreatment systems are sensitive to the operating schedule. Low quality fuel, lubricants, or fluids may cause increases in exhaust back pressure or clogging resulting in loss of power. An authorized Perkins distributor/dealer can determine if the engine aftertreatment systems require a service.

NOx Reduction System (NRS) – The NRS is monitored. An authorized Perkins distributor/dealer can determine if the NRS needs service.

FUEL INJECTORS – Fuel injector tips are subject to wear as a result of fuel contamination. This damage can cause the following conditions: an increase in fuel consumption, black smoke, misfire and rough running engine. The fuel injector should be inspected, tested, and replaced, if necessary. Fuel injectors can be tested by an authorized Perkins distributor/dealer .

TURBOCHARGER – Refer to this Operation and Maintenance Manual, "Turbocharger - Inspect" for information on inspection of the turbocharger.

ELECTRONIC ENGINE CONTROL (ECM) – The ECM is the control computer of the engine. The ECM provides power to the electronics. The ECM monitors data that is input from the sensors of the engine. The ECM acts as a governor in order to control the speed and the power of the engine.

Erratic behavior of the engine may indicate a need for repair to the ECM. Your Perkins distributor/dealer is equipped with the necessary tools, personnel, and procedures in order to perform this service.

The owner is encouraged to keep adequate maintenance records. However, the absence of such records will not invalidate the warranty. Refer to the Operation and Maintenance Manual, "Maintenance Log" (Reference Materials Section).

The owner may perform routine maintenance, repairs, and other work that is outside of the warranty. The work may be done at any repair facility. Such work does not need to be performed at a designated station that is determined by the warranty in order for the warranty to remain in force.

Reference Information Section

www.perkins.com

NOTICE
Dependant upon engine type and application.

Reference Materials

i04224089

Engine Protection Plans (Extended Service Contract)

Extended Service Contracts-purchased in minutes,
protected for years.

Extended Service Contracts (ESC) protect you from the stress that unexpected repair work brings to your life by covering the cost of getting your engine up and running again. Unlike other extended warranties, Perkins Platinum ESC protects you against all component part failures.

Purchase peace of mind from only £0.03 / \$0.05 / euro 0.04 a day and let an ESC make your dreams a reality.

Why buy an Extended Service Contract?

1. No surprises - total protection from unexpected repair cost (parts, labor, and travel).
2. Enjoy longer lasting product support from Perkins global network.
3. Genuine Perkins parts ensure continued engine performance.
4. Highly trained technicians carry out all repairs.
5. Transferable coverage should you sell your machine.

Flexible coverage provides the right level of protection for your Perkins Engine. Coverage can be extended to 2 years/ 1,000 hours right up to 10 year/ 40,000

You can buy an ESC at any time during standard warranty - even the last day!

Each Perkins Distributor has highly trained and experienced Perkins Product Support Service Technicians. The Support Service are equipped, and available around the clock to get your engine running again with the minimum of downtime. Buying an ESC means that you get all this for free.

To purchase an Extended Service Contract, is quick and simple! Contact your local Perkins Distributor now and the distributor can provide you with a quote in minutes. You can locate your nearest Perkins Distributor by visiting:

Index

A

After Starting Engine	48
After Stopping Engine	57
Alarms and Shutoffs	31
Alarms.....	31
Shutoffs.....	31
Testing	31
Alternator - Inspect.....	75
Alternator and Fan Belts - Inspect/Adjust	75
Adjustment.....	75
Inspection	75
Alternator and Fan Belts - Replace	76

B

Battery - Replace.....	76
Battery Electrolyte Level - Check	77
Battery or Battery Cable - Disconnect.....	77
Before Starting Engine	13, 46
Belts - Inspect/Adjust/Replace (Air Pump Belt)	77
Adjust.....	78
Inspection	77
Belts - Inspect/Replace (Air Pump belt)	78
Belt Tension Frequency	78
Burn Prevention.....	9
Batteries.....	10
Coolant	10
Induction System	10
Oils.....	10

C

California Emission Control Warranty Statement	107
Emissions Warranty.....	107
Cold Weather Operation	53
Hints for Cold Weather Operation	53
Idling the Engine	54
Recommendations for Coolant Warm Up....	54
Recommendations for the Coolant.....	53
Viscosity of the Engine Lubrication Oil	53
Cold Weather Starting.....	46
Configuration Parameters	45
Coolant (Commercial Heavy-Duty) - Change	79
Drain	79
Fill	80
Flush	80

Coolant (ELC) - Change.....	80
Drain	81
Fill	82
Flush	81
Coolant Level - Check.....	82
Engines With a Coolant Recovery Tank	82
Engines Without a Coolant Recovery Tank.....	83
Coolant Temperature Regulator - Replace	83
Cooling System Supplemental Coolant Additive (SCA) - Test/Add.....	84
Add the SCA, If Necessary	84
Test for SCA Concentration	84
Crankcase Breather (Canister) - Replace.....	85
Crushing Prevention and Cutting Prevention..	12

D

Diagnostic Lamp.....	44
Diesel Particulate Filter - Clean.....	86
Diesel Particulate Filter Regeneration	49
Modes of Regeneration	50
Regeneration	49
Regeneration Indicators	49
Regeneration Switch	50
Soot Level Monitoring and Indicators	50

E

Electrical System.....	14
Grounding Practices	14
Emergency Stopping.....	57
Emissions Certification Film	27
Emissions Warranty Information	108
Maintenance Recommendations.....	108
Engine - Clean.....	87
Aftertreatment.....	88
Engine Air Cleaner Element - Replace	88
Engine Air Cleaner Service Indicator - Inspect	88
Test the Service Indicator	88
Engine Air Precleaner - Check/Clean	88
Engine Diagnostics	44
Engine Electronics.....	15
Engine Mounts - Inspect.....	89
Engine Oil and Filter - Change	89
Drain the Engine Oil.....	90
Fill the Engine Crankcase.....	91
Replace the Oil Filter	90

Engine Oil Level - Check.....	89	Fuel System - Prime.....	94
Engine Operation	49	Mechanical Priming Pump.....	94
Engine Operation and Active		Fuel System Secondary Filter - Replace	99
Regeneration	49	Fuel Filter with Canister.....	99
Reduction of Particulate Emissions.....	49	Fuel Tank Water and Sediment - Drain	100
Engine Operation with Active Diagnostic		Drain the Water and the Sediment	100
Codes	44	Fuel Storage Tanks.....	100
Engine Operation with Intermittent		Fuel Tank	100
Diagnostic Codes	44		
Engine Protection Plans (Extended Service		G	
Contract).....	110	Gauges and Indicators	31
Engine Starting.....	13, 46	Aftertreatment Lamps	32
Engine Stopping.....	13, 57	Indicators and Lamps	32
Engine Valve Lash - Check	91	General Hazard Information.....	6
		Containing Fluid Spillage.....	8
F		Dispose of Waste Properly	9
Fan Clearance - Check (Industrial Engine).....	92	Fluid Penetration	8
Fault Logging.....	44	Inhalation	8
Features and Controls.....	31	Pressure Air and Water	7
Federal Emission Control Warranty	106	General Information	16
Emissions Warranty.....	106	Glow Plugs (ARD Combustion) - Replace	100
Fire Prevention and Explosion Prevention.....	10	Remove the Glow Plug for the After	
Fire Extinguisher.....	12	Regeneration Device (ARD)	101
Lines, Tubes, and Hoses	12		
Regeneration	12	H	
Fluid Recommendations	59, 63, 65	Hoses and Clamps - Inspect/Replace.....	101
Diesel Fuel Characteristics.....	61	Replace the Hoses and the Clamps	101
Diesel Fuel Requirements	59		
ELC Cooling System Maintenance.....	68	I	
Engine Oil	64	Important Safety Information.....	2
General Coolant Information	65		
General Information.....	59	L	
General Lubricant Information.....	63	Lifting and Storage	29
Foreword	4		
California Proposition 65 Warning.....	4	M	
Literature Information	4	Maintenance Interval Schedule.....	74
Maintenance	4	Commissioning	74
Maintenance Intervals	5	Daily.....	74
Operation	4	Every 1000 Service Hours.....	74
Overhaul	5	Every 2000 Service Hours.....	74
Safety.....	4	Every 250 Service Hours or 6 Months.....	74
Fuel and the Effect from Cold Weather.....	55	Every 3000 Service Hours.....	74
Fuel Conservation Practices	51	Every 3000 Service Hours or 2 Years	74
Fuel Filter (In-Line) - Replace	92	Every 50 Service Hours or Weekly	74
Fuel Injector - Test/Change	93	Every 500 Service Hours.....	74
Identification of a suspect Fuel Injector	93	Every 500 Service Hours or 1 Year	74
Fuel Related Components in Cold Weather ...	55	Every 6000 Service Hours or 3 Years	74
Fuel Filters	55	When Required.....	74
Fuel Heaters	55		
Fuel Tanks	55		

Maintenance Recommendations	71	S	
Maintenance Section.....	58	Safety Messages.....	6
Model View Illustrations (Engines and		(1) Universal Warning	6
Aftertreatment)	16	Safety Section	6
403F-15T	16	Self-Diagnostics	44
404F-22	17	Sensors and Electrical Components	
404F-22T	18	(Engine and Aftertreatment).....	35
Aftertreatment System.....	21	Severe Service Application	72
Engine with Low Mounted Air Pump.....	22	Environmental Factors.....	72
Off Engine Parts	22	Incorrect Maintenance Procedures	73
Monitoring System.....	34	Incorrect Operating Procedures	73
Programmable Options and Systems		Starting Motor - Inspect.....	103
Operation	34	Starting the Engine.....	47
Monitoring System (Engine Warning		Starting the Engine	47
Indicators).....	33	Starting with Jump Start Cables (Do Not	
Mounting and Dismounting	12	Use This Procedure in Hazardous	
		Locations that have Explosive	
O		Atmospheres)	47
Operation Section.....	29	Stopping the Engine	57
Overspeed.....	34	System Pressure Release.....	71
		Coolant System	71
P		Engine Oil	71
Plate Locations and Film Locations	27	Fuel System.....	71
Product Description.....	23		
Aftermarket Products and Perkins		T	
Engines	26	Table of Contents	3
Electronic Engine Features	25	Turbocharger - Inspect (If Equipped)	103
Engine Diagnostics.....	25	Inspecting	103
Engine Service Life.....	25	Removal and Installation	103
Engine Specifications	24		
Product Identification Information	27	W	
Product Information Section.....	16	Walk-Around Inspection	104
Product Lifting	29	Inspect the Engine for Leaks and for Loose	
Lifting Eyes with Top Mounted		Connections	104
Aftertreatment.....	29	Warranty Information.....	106
Product Storage (Engine and		Warranty Section.....	106
Aftertreatment)	29	Water Pump - Inspect.....	105
Condition for Storage.....	30	Welding on Engines with Electronic	
		Controls	71
R			
Radiator - Clean	102		
Radiator Pressure Cap - Clean/Replace.....	103		
Reference Information.....	28		
Record for Reference	28		
Reference Information Section	110		
Reference Materials	110		
Refill Capacities.....	58		
Cooling System.....	58		
Lubrication System	58		

Product and Dealer Information

Note: For product identification plate locations, see the section "Product Identification Information" in the Operation and Maintenance Manual.

Delivery Date: _____

Product Information

Model: _____

Product Identification Number: _____

Engine Serial Number: _____

Transmission Serial Number: _____

Generator Serial Number: _____

Attachment Serial Numbers: _____

Attachment Information: _____

Customer Equipment Number: _____

Dealer Equipment Number: _____

Dealer Information

Name: _____ Branch: _____

Address: _____

Dealer Contact

Phone Number

Hours

Sales: _____

Parts: _____

Service: _____

SEBU8609
©2020
All Rights Reserved