

# Installation, Operation and Maintenance Manual

---



## **RECEIVING AND INSPECTION**

Upon receiving the unit, check for any interior and exterior damage, and if found, report it immediately to the carrier. Also check that all accessory items are accounted for and are damage free.

## **WARNING!!**

Improper installation, adjustment, alteration, service or maintenance can cause property damage, injury or death. Read the installation, operating and maintenance instructions thoroughly before installing or servicing this equipment. **ALWAYS** disconnect power prior to working on module.

**Save these instructions:** This document is the property of the owner of this equipment and is required for future maintenance. Leave this document with the owner when installation or service is complete.

---



# Table of Contents

WARRANTY.....	4
INSTALLATION.....	5
Panel Mounting.....	5
Wiring.....	5
Control Power.....	5
Main Lighting Power.....	5
Electrical.....	6
Low Voltage Wiring.....	7
Component Description.....	8
OPERATION.....	9
HMI Configuration.....	9
Settings Menu.....	9
Normal Operation Screens.....	10
Options.....	10
Factory Settings.....	11
Saving Changes.....	12
Zone Config.....	12
Interlock Config.....	13
Schedule Settings.....	14
Holiday Settings.....	15
Schedule Override.....	15
Service Settings.....	15
Daylight Savings Time Setting.....	15
ECPM03 Circuit Board.....	16
General.....	16
Installation.....	16
HMI Configuration.....	21
HMI Menu Tree.....	22
Network.....	23
Communication Module.....	23
DDC Points.....	23
BACnet.....	23
BACnet IP and BACnet MS/TP Points.....	26
LonWorks.....	29
LonWorks Points.....	29
TROUBLESHOOTING.....	33
HMI Fault / Warnings.....	33
Troubleshooting Chart.....	34
Component Check/Testing.....	35
MAINTENANCE.....	36
General Maintenance.....	36

## WARRANTY

This equipment is warranted to be free from defects in materials and workmanship, under normal use and service, for a period of 24 months from date of shipment.

This warranty shall not apply if:

1. The equipment is not installed by a qualified installer per the MANUFACTURER'S installation instructions shipped with the product.
2. The equipment is not installed in accordance with federal, state and local codes and regulations.
3. The equipment is misused or neglected.
4. The equipment is not operated within its published capacity.
5. The invoice is not paid within the terms of the sales agreement.

The MANUFACTURER shall not be liable for incidental and consequential losses and damages potentially attributable to malfunctioning equipment. Should any part of the equipment prove to be defective in material or workmanship within the 24 month warranty period, upon examination by the MANUFACTURER, such part will be repaired or replaced by MANUFACTURER at no charge. The BUYER shall pay all labor costs incurred in connection with such repair or replacement. Equipment shall not be returned without MANUFACTURER'S prior authorization and all returned equipment shall be shipped by the BUYER, freight prepaid to a destination determined by the MANUFACTURER.

**Note: To receive warranty coverage, register this product by filling out the startup and Maintenance Document. Fax the form to 1-919-554-9374 or call 1-866-784-6900 for email information.**

# INSTALLATION

## Panel Mounting

The Lighting Control system is mounted in a NEMA 1 enclosure. The panel should be mounted indoors in a dry, low dust area. There must be 3 feet of clearance in front of the panel to allow easy access for operation and maintenance. Install in accordance with the latest National Electric Code and/or local requirements.

## Wiring

The Lighting Control panel is made of stainless steel, and has knockouts on the top and bottom of the panel.

## Control Power

**120V AC** control power must be supplied to terminal H1 and a neutral to N1 from a maximum **20A** breaker.

## Main Lighting Power

The panel can contain contactors and/or terminals to control external contactors. All power for the lights themselves must be supplied from external breakers. **The lighting panel contains no overcurrent or short circuit protection.** The breakers supplying the lighting contactors should be sized to keep the current draw from rising above the rating of the contactor.

Calculating wire size and voltage drop is the responsibility of the installer.

## External Contactors

This system can control external contactors provided they have **120V AC** coils. A hot and neutral should be run from the lighting panel terminal blocks to the coil of the external contactors. No external power source or neutral should be connected to these wires.

Wiring for the contactor closure signal is required as well. Terminal CNC (Confirmation Common) and CN# must be wired through a Normally Open (NO) auxiliary contact on each contactor. These wires are low voltage signal wires that **must not be connected to any other voltage or electrical system.** The wire connected to CNC can be used as the common for multiple contactors. The CN# wires must be wired directly to each contactor.

## Electrical

Before connecting power to the control panel, read and understand the entire section of this document. As-built wiring diagrams are furnished with each control by the factory, and are attached either to the door of the unit or provided with a paperwork packet.

Electrical wiring and connections should be done in accordance with local ordinances and the National Electric Code, ANSI/NFPA70. Be sure the voltage and phase of the power supply and the wire amperage capacity is in accordance with the unit nameplate.

1. Always **disconnect power** before working on or near this equipment. Lock and tag the disconnect switch or breaker to prevent accidental power up. Make certain that the power source is compatible with the requirements of your equipment. The wiring schematic identifies the **proper phase and voltage** of the equipment.
2. Before connecting control to power source, verify power line wiring is de-energized.
3. Secure the power cable to prevent contact with sharp objects.
4. Do not kink power cable and never allow the cable to come in contact with oil, grease, hot surfaces or chemicals.
5. Before powering up the system, make sure that the interior of the control is free of loose debris or shipping materials.
6. If any of the original wire supplied with the system must be replaced, it must be replaced with type THHN wire or equivalent.

### **WARNING!!**

**Disconnect power before installing or servicing control. High voltage electrical input is needed for this equipment. This work should be performed by a qualified electrician.**

**Table 1 – Wire Ampacity**

Wire Size AWG	Maximum Amps
14	15
12	20
10	30
8	50
6	65
4	85

## Low Voltage Wiring

Modbus communication over CAT-5 cables for display(s) and remote equipment.

1. **HMI**s are connected to the ECPM03 board through a CAT-5 cable. The HMI has two RJ-45 connectors for Modbus communication. The HMI connects to port J4 or J5 (RJ-45) of the ECPM03 board. The other RJ-45 port of the HMI will typically be occupied by a RJ-45 end-of-line terminator or can be used as a connection point for another HMI.
2. **Two end-of-line terminators** are included in each panel. They are typically plugged in at the factory on port J3 and/or port J4, or in the back of the first HMI. If another HMI or other equipment needs to connect to a port occupied by an end-of-line terminator, it shall be removed and placed on the HMI or equipment that became connected at the end of the Modbus network.
3. **Modbus Communication.** If other pieces of equipment are connected to this panel, a CAT-5 cable will also be used to run the Modbus communication between these devices. The cable would be plugged in port J3 of the ECPM03 board. The end-of-line terminators should then be relocated from J3 to the device being added on.
4. **DDC (Direct Digital Control) Wiring.** For communications from a remote Building Management System (BMS), low voltage communication wiring is required. This wiring will plug into a gateway that is mounted in the Lighting Control panel, which then connects to J1 on the ECPM03 board via CAT-5 connection.

## 24V Interlock connections

There are four connections on the board that are for optional interlock connections. These connections connect through dry contacts only. The connections are IL1A, IL1B, 1L2A, and IL2B. Normally Open (NO) is the inactive status.

**Figure 1 – Interlock Connections**

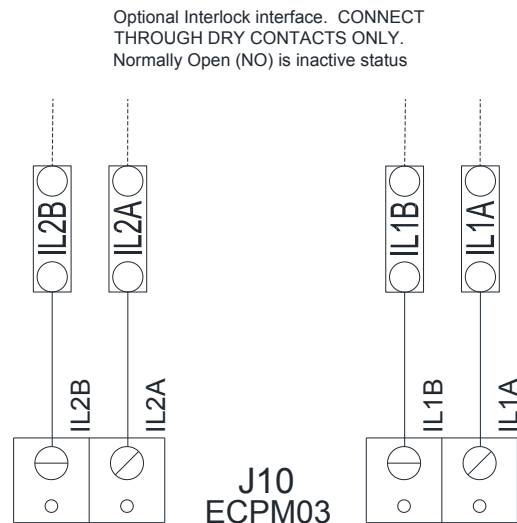

## Component Description

### Contactors (C-x)

There are three options for lighting loads/contactors. Each panel can control up to 8 contactors:

- 40 amp ballast/tungsten/general load
- 70 amp ballast/tungsten; 50 amp general load
- Customer supplied contactor

### Auto/Manual Switches (SW-x)

The Auto/Off/Manual switches electrically override the control board and allow full manual operation of the lighting contactors.

**Auto:** In this position, the output of the control board is connected to the lighting contactor. If the board outputs a signal, the contactor will engage.

**Off:** Placing the switch in the center “OFF” position will override the control board and keep the lighting contactor off.

**Manual:** The manual position will turn the contactor ON and keep it ON, overriding inputs and the control board.

**Power Supply (PS-01)** - Converts input voltage of **100-240V AC** to an output voltage of **24V DC**.

**End Of Line Resistor (EOL120A)** – Used for a termination point in Modbus network.

**Inputs** – Various inputs may be assigned depending on logic, and schedule settings. The most common inputs are:

- HMI switch – This can force the input in zones On/Off depending on occupied setting.
- Occupancy sensor – Detects motion in the area to activate the lights depending on [Zone Config](#) (page 12) and [Schedule Settings](#) (page 14).
- Photocell sensor – Detects lighting threshold. If the sensor detects daylight then lights will be off. If the sensor does not detect daylight then lights will be on.

**NOTE: When installing the lighting sensors, it is recommended to set the sensor’s internal timer to the lowest timer setting possible. Use the override control settings on the Lighting Control Package to control the amount of time for the sensor (light) to be ON.**

Figure 2 – Contactors

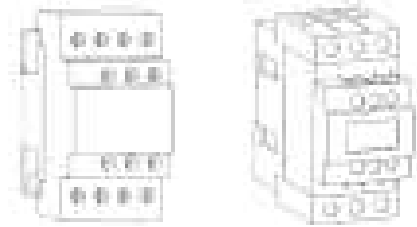

Figure 3 – Switch Panel

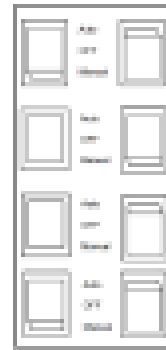

Figure 4 – Power Supply



Figure 5 – EOL Resistor



# OPERATION

## HMI Configuration

### General Overview

The HMI allows the user to view operating information regarding lighting group assignments, HMI sensor group assignments, external sensor assignments, status and configurations.

At any point in time the user can access the HMI configuration screen. This is achieved by simultaneously pressing both **top** buttons, and holding them for **1 second**. When this occurs, the screen will look similar to the image to the right. To exit this screen, simply press the MENU button.

**Figure 6 – HMI Menu Screen**

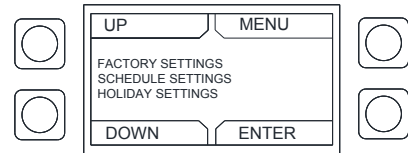

Also, during initial HMI configuration, each HMI must have a unique Modbus address or HMI number. To assign this, simultaneously press both **bottom** buttons and hold them for **1 second**. When this occurs, the user will be able to assign a number to the HMI. Once the HMI number is assigned, press **SAVE** to exit the screen. In this configuration setting, the user may adjust the contrast settings under “Advanced Options”. The user may adjust the setting from 0 to 10. Setting the contrast to 0 is the lowest setting available and 10 is the highest contrast setting available. The factory default contrast setting is 5.

The HMI menu system is illustrated on **page 22** and allows full access to every configurable parameter in the HMI. The parameters are factory configured to the specific application. Parameters may need to be modified to fine tune automatic operation or to add an HMI to a system after the original setup.

### Settings Menu

Simultaneously press both **top** buttons and hold them for **1 second** to enter the settings menu.

**Up** = Moves selection up

**Menu** = Returns to previous selection

**Enter** = Enters selection

**Down** = Moves selection down

**Factory Settings:** Contains selection for inputs, outputs, zones, HMIs, zone configurations, and interlock configurations.

**Schedule Settings:** Allows user to set a lighting schedule based on day and time.

**Holiday Settings:** User may use this setting to create a holiday schedule to keep lights on or turn them off without editing the normal schedule.

**Schedule Override:** Allows user to override all schedule settings.

**Service Settings:** Allows user access to monitor service features.

## Normal Operation Screens

**Prev** = Moves to previous zone, if more than one is assigned.

**Next** = Moves toward next zone, if more than one is assigned.

**Force Off** = This option is available when in an “Occupied Schedule”. Pressing ‘Force Off’ will enter the off state. It will stay in this state until “Auto” is pressed, then return back to the set schedule. ‘Force Off’ will also reset to auto at the end of the scheduled period.

**Force On** = This option is available when the system is not within a scheduled setting. When “Force On” is pressed the Zone, Status, Forced On, and Timer are displayed. Once the timer has expired or “Auto” is pressed, the setting will return to the previous function.

**Auto** = Appears when ‘Force On’ or ‘Force Off’ is selected.

**Add Time** = Appears when in an “Occupied Schedule”. Pressing ‘Add Time’ will extend the length of the override time setting to the end of the occupied schedule period.

## Options

Allows user to set Language, HMI Dimmer, and Dim delay on the HMI screen.

Language: English

HMI Dimmer: Disabled/Enabled

Dim Delay: 2-200 (seconds)

**Figure 7 – Operation Screen**

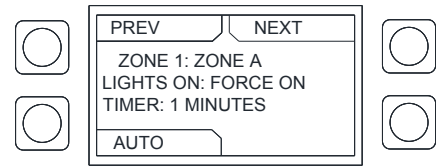

**Figure 8 – Options Screen**

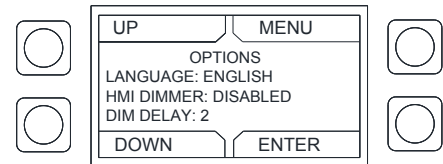

## Factory Settings

**NOTE:** If you are making changes in "Factory Setting" or to a schedule that is currently running in an Occupied Schedule, the board will go through a power cycle. Any lights that are active may turn off for a period of time.

**Number of Inputs:** Up to seven (7) **120V AC** inputs can be assigned to the panel for photocells (light sensor), switches, and occupancy sensors per panel.

**Number of Outputs:** There are eight (8) outputs per panel that can be assigned to control the lighting. Outputs must control lights through a relay or contactor. Multiple contactors may be assigned per zone.

**Number of Zones:** The maximum number of zones that can be created per system are limited to the number of outputs that are used by the system. These zones can be viewed on the main menu screen.

**Number of HMIs:** You may have a maximum of ten (10) HMI assigned to a lighting control system.

**Assign Out:** Assigning output number to assigned zone name. A zone name is assigned by using the Application Launcher program CAAL.

**Zone Configuration:** Zones are controlled by board inputs, user defined schedules, and HMI button presses. Multiple lights may be assigned to one zone.

**Interlock Configuration:** These interlocks can be used for fire systems, security systems, or other Building Management Systems (BMS). The two interlocks are labeled IL1 and IL2 on the ECPM03 circuit board. The interlocks can be assigned to turn all of the lights on or all of the lights off when the pins are jumped (closed). If IL1 and IL2 are activated, the IL1 interlock will take priority.

## Saving Changes

To save changes made on the HMI for any of the settings, press “Menu” until the ‘**Save Changes?**’ screen appears.

- Pressing **Discard** will return you to the main menu, and will not save any of your changes.
- Pressing **Cancel** will keep you in the setting options. It will not discard the changes you have made.
- Pressing **Save** will save all of your changes. A screen “Saving...” will appear followed by a “Firmware” screen, and then will return to the main menu.

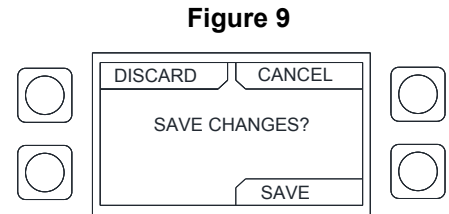

## Zone Config

Verify all “Inputs”, “Outputs”, “Zones”, and “HMIs” have been assigned under “Factory Settings”. This will ensure all settings are configured so you may create an “Occupied Schedule”.

Select *FACTORY SETTINGS > ZONE CONFIG > ZONE 1* (or another zone) to configure.

**Input Function:** The settings available are “None”, “Override”, and “On While”.

- **None:** The lighting control will follow a scheduled setting or forced HMI control.
- **Override Mode:** In this mode the lighting control calls for the input to be on, and for the amount of the override time afterwards. The input will shut off when the override time has expired or the user has pressed the “Auto” button on the HMI.
- **On While Mode:** In this mode the lighting control will call for the light to be on only while the input is on. The input will shut off when the override time has expired, or the user have pressed “Auto” button on the HMI.
- **Override Time:** User can set timer for override function. Up to two hours can be programmed for the lights to stay on, and then the light setting will return to the previous lighting control.

**NOTE: Some areas have adopted lighting codes that allow a maximum of 30 minute overrides. Verify local code requirements.**

**Input Logic:** This setting determines how two inputs are handled to actuate the lights. There are two options which are **AND/OR**. Their functionality is:

- **AND:** The logic can be set that Input 1 **AND** Input 2 need to be satisfied to actuate the zone.
- **OR:** The logic can be set that Input 1 **OR** Input 2 needs to be satisfied to actuate the zone.

**Schedule Logic:** Schedule Logic is how inputs and a set schedule interact in controlling the zone (relevant only if an input and a schedule control the zone). There are two options which are **AND/OR**. Their functionality is:

- **AND:** The schedule and input logic must be satisfied to turn the Zone on. The Zone must be assigned to a schedule, and the schedule must be enabled. See [Schedule Settings](#) (page 14).
- **OR:** The schedule or input logic can turn on the Zone.

**The zone must be assigned in schedule settings, and there must be an input assigned to the zone.**

## Interlock Config

Verify the interlock wiring is connected to the correct board input.

There are two interlocks available.

The enabled and disabled setting tells the board whether or not to process the interlock.

The On/Off setting tells the board what to do when processing the interlocks. If the interlocks are set to **OFF**, then when the interlock is open, all lights will turn off. If the interlocks are set to **ON**, then when the interlock is open, all lights will turn on.

**Note: If IL1 and IL2 are activated, the IL1 interlock will take priority.**

**Figure 10 – Interlock Screen**

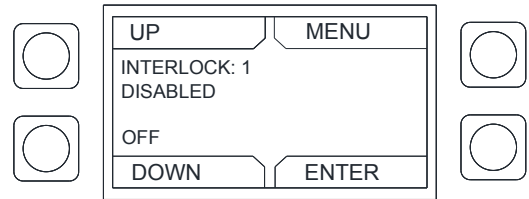

## Schedule Settings

Select 'Schedule Settings', press 'Enter'. Select a schedule to edit.

The following options will be available:

- Enable: Yes/No
- Repeat: No/Yes
- Start Day: Mon – Sun
- End Day: Mon – Sun
- Start Time: 00:00 AM/PM
- End Time: 00:00 AM/PM
- Zones: User can assign a schedule to one of the zones listed.

**Figure 11 - Select Schedule**

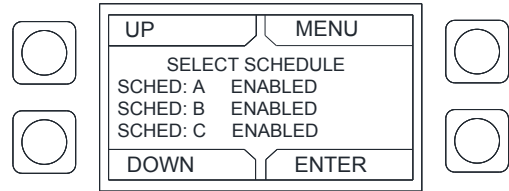

To create a scheduled daily setting, go to 'Enable' and select 'Yes'. If you need to have the same settings for consecutive days, select 'Yes' under 'Repeat'. Select a 'Start Day', 'End Day', 'Start Time', and 'End Time'.

Select which zones you would like to follow this schedule.

An example of a set schedule is shown to the right. This setting will control the lights 'Zone 1' and 'Zone 2' Monday – Friday, and will be active from 7:00 AM to 4:00 PM. There would not be a lighting schedule set for weekend, "Force On" would need to be used to turn on the lights.

```

ENABLE: YES
REPEAT: YES
START DAY: MON
END DAY: FRI
START TIME: 7:00 AM
END TIME: 4:00 PM
ZONE: ZONE 1
      ZONE 2
    
```

Below is an example of a weekly custom setting.

ENABLE: YES REPEAT: NO START DAY: MON END DAY: MON START TIME: 10:00 AM END TIME: 8:00 PM ZONE: ZONE 1 ZONE 2	ENABLE: YES REPEAT: NO START DAY: TUE END DAY: TUE START TIME: 10:00 AM END TIME: 5:00 PM ZONE: ZONE 1 ZONE 2	ENABLE: YES REPEAT: NO START DAY: WED END DAY: WED START TIME: 10:00 AM END TIME: 8:00 PM ZONE: ZONE 1 ZONE 2	ENABLE: YES REPEAT: NO START DAY: THU END DAY: THU START TIME: 10:00 AM END TIME: 5:00 PM ZONE: ZONE 1 ZONE 2	ENABLE: YES REPEAT: YES START DAY: FRI END DAY: SUN START TIME: 10:00 AM END TIME: 11:00 PM ZONE: ZONE 1 ZONE 2
--	--	--	--	--

## Holiday Settings

Select 'Holiday Settings'. Select a schedule to edit.

Holiday Enabled: Enables the Holiday  
 Holiday Start Date: Edit Date of Holiday  
 Month/Day  
 Holiday End Date: Edit Date of Holiday  
 Month/Day

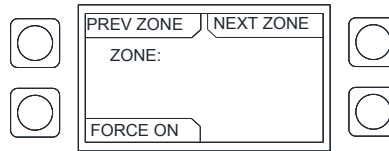

**Figure 12 – Holiday Schedule**

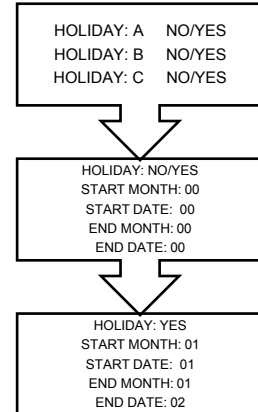

When the system is in the holiday schedule, the main menu will display:  
 "Zone:"  
 "Status: Lights Off".

If the lights need to be turned On/Off, you will need to press "Force On" / "Force Off". The lights will stay On/Off for the programmed override time.

## Schedule Override

Using "Schedule Override" will override the current schedule. The schedule will stay overridden until the schedule override is turned off.

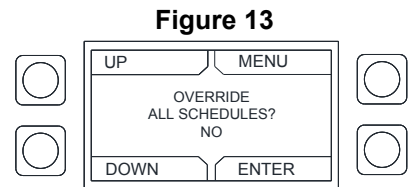

**Figure 13**

## Service Settings

"Service Settings" allows you to view the status of the lighting contactors.

## Daylight Savings Time Setting

The daylight saving time is programmed at the factory for each geographical location using the ECPM03 board.

To view the daylight savings setting, select 'Time Settings' > 'Local Time Offset'

Use the Up or Down arrows on the board to update the setting if needed.

**Figure 14 – ECPM03 LCD Screen**

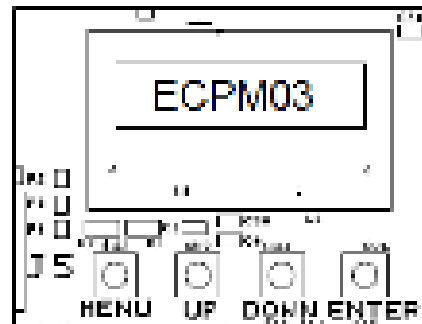

## **ECPM03 Circuit Board**

The ECPM03 circuit board is the main control of the system. It receives all the digital and analog inputs, delivers the digital outputs, and sends out messages to other devices.

### **General**

This control panel utilizes a mixture of traditional controls along with a “smart” digital circuit board controller, referred to as the ECPM03 board. It is intended to be installed within a UL508A electrical control package. The board is powered by **24 Volts DC**, which is provided by an approved **10-20 Watt** class 2 power supply included inside the panel.

Some parts of the ECPM03 board can be electrically live and some surfaces can be hot. Inappropriate use and incorrect installation or operation creates the risk of injury to personnel and/or damage to equipment. All operations concerning installation, commissioning and maintenance must be carried out by qualified, skilled person who is familiar with the installation, assembly, commissioning, and operation of the control panel and the application for which it is being used.

### **Installation**

Make sure you properly handle the components, and avoid excessive mechanical stress. Do not bend any components during transport, handling, installation or maintenance. Do not touch any electronic components or contacts. This board contains electrostatically sensitive components, which can easily be damaged by inappropriate handling. Static control precautions must be adhered to during installation, testing, servicing and repairing of this board. Component damage may result if proper procedures are not followed.

To ensure proper operation, do not install the board where it is subjected to adverse environmental conditions such as combustible, oily, or hazardous vapors; corrosive chemicals; excessive dust, moisture or vibration; direct sunlight or extreme temperatures.

The ECPM03 board may be mounted by means of DIN rail clips and board standoffs or by standoffs alone. It will be mounted in a NEMA 1 enclosure for indoor use only.

When working on live panel controllers, applicable national safety regulations must be observed. The electrical installation must be carried out according to the appropriate regulations (e.g. cable cross-sections, circuit breaker, protective earth [PE] connection). While this document does make recommendations in regards to these items, national and local codes must be adhered to.

**NOTE: The board's battery should be changed every 9-10 years.**

FIELD WIRING:

The following is for reference only. All **120 Volt AC** field wiring is landed on terminal blocks, not on the board itself. See Installation section for details. Low voltage class 2 field wiring may be landed at J3, J4, J5 or J10 connectors only, as indicated by the panel labeling and installation schematic. Provision for spacing and routing of the field wiring is provided in the panel.

FACTORY WIRING:

The connectors below are intended to be used for factory wiring only by a UL508A panel shop:



J7, J8, J9 are provided for the control of **120V AC** relays, contactors, solenoids and shunt trip breakers. Under no circumstances shall any lighting or motor loads be directly connected to these connectors.

J1, J2, J6, are reserved for low voltage class 2 factory wiring.

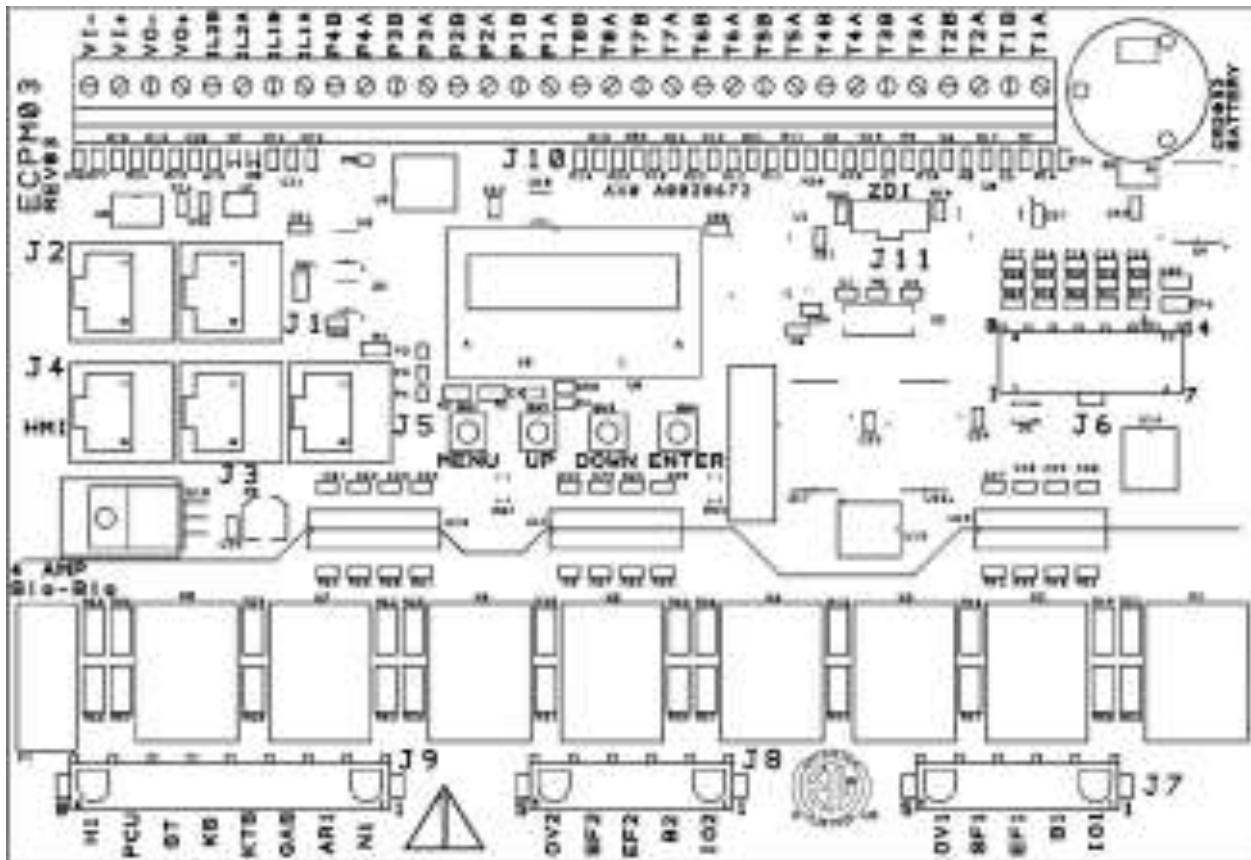
**Figure 15 – ECPM03 Board**



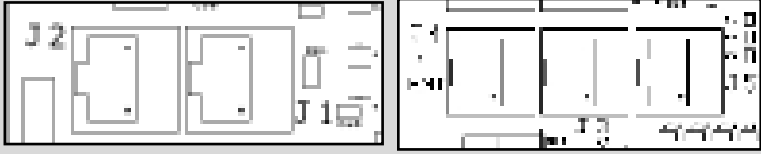

## Connector Descriptions

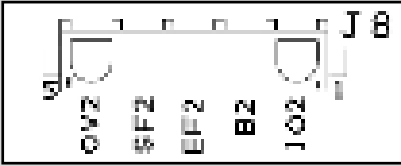
<p>RJ45 Connectors</p>	
<p>J1, J2 - Modbus master network connectors, feed through RJ45s, which conform to the Modbus pin out for RS485 2 wire differential Modbus RTU standard. J1 and J2 are utilized for Comm Module and external BMS interface. No field wires should be connected to J1 or J2.</p>	<p>J3, J4, J5: Modbus slave network connectors feed through RJ45s, which conform to the Modbus pin out for RS485 2 wire differential Modbus RTU standard. See <a href="http://www.modbus.org">http://www.modbus.org</a>. Modbus communication is not configured for third party integration without additional components. All CORE network, PCU AFM, HMI, and VFDs report through J3, J4 and J5. The order of connection is irrelevant.</p>
<p>Connector J6 contains factory only wiring for low voltage connections</p>	
<p>Pin 1 - <b>24V DC</b> power input (positive side) to the board.</p> <p>Pin 2 through pin 7 - Each open collector relay output (RO) sources <b>100 mA</b> max and is suitable for driving <b>24V DC</b> relays or indicator lamps.</p> <p>Pin 8 through pin 12 - <b>4-20 mA</b> current inputs. 150 Ohm impedance to <b>24V DC</b> ground pin 14.</p>	<p>Pin 13 - Chassis ground connection, this pin connects to the <b>24V DC</b> ground through a paralleled 1000pf <b>2000V</b> capacitor and a 100k Ohm 1/4W resistor.</p> <p>Pin 14 - <b>24V DC</b> power input (negative side) to the board. Ground or common side of the low voltage circuitry.</p>
<p>Connector J7 contains <b>120V AC</b> control connector for factory only wiring</p>	
<p>Pin 1 - (IO1) output and input, this pin can source <b>120V AC</b> and detect the presence of <b>120V AC</b>.</p> <p>Pin 2 - (B1) input, this pin can detect the presence of <b>120V AC</b>.</p> <p>Pin 3 - (EF1) output and input, this pin can source <b>120V AC</b> and detect the presence of <b>120V AC</b>.</p>	<p>Pin 4 - (SF1) output, this pin can source <b>120V AC</b>.</p> <p>Pin 5 - (OV1) input, this pin can detect the presence of <b>120V AC</b>.</p>

<p>Connector J8 contains <b>120V AC</b> control connector for factory wiring</p>	
<p>Pin 1 - (IO2) output and input, this pin can source <b>120V AC</b> and detect the presence of <b>120V AC</b>.</p> <p>Pin 2 - (B2) input, this pin can detect the presence of <b>120V AC</b>.</p> <p>Pin 3 - (EF2) output and input, this pin can source <b>120V AC</b> and detect the presence of <b>120V AC</b>.</p>	<p>Pin 4 - (SF2) output, this pin can source <b>120V AC</b>.</p> <p>Pin 5 - (OV2) input, this pin can detect the presence of <b>120V AC</b>.</p>

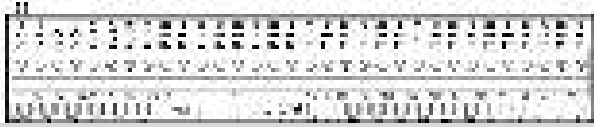
<p>Connector J9 contains <b>120V AC</b> control connector for factory only wiring</p>	
<p>Pin 1 - (N1) this is the neutral or return path for the detection of <b>120V AC</b> by the input pins. It would be connected to the neutral side of the <b>120V AC</b> supply.</p> <p>Pin 2 - (AR1) input, this pin can detect the presence of <b>120V AC</b>.</p> <p>Pin 3 - (GAS) output, this pin can source <b>120V AC</b>.</p> <p>Pin 4 - (KTS) input, this pin can detect the presence of <b>120V AC</b>.</p>	<p>Pin 5 - (KS) output, this pin can source <b>120V AC</b>.</p> <p>Pin 6 - (ST) output, this pin can source <b>120V AC</b>.</p> <p>Pin 7 - (PCU) input, this pin can detect the presence of <b>120V AC</b>.</p> <p>Pin 8 - (H1) this is the <b>120V AC</b> 50/60Hz input to the board, it feeds through an on board 10 Amp Slow-Blow fuse and is used to source <b>120V AC</b> to all the pins described as <b>120V AC</b> outputs. The total current draw of all the <b>120V AC</b> outputs must not exceed 10 Amps.</p>

<p>Connector J10 contains low voltage field wiring connections</p>	
<p>Pin 1 through pin 16 - thermistor probe inputs. 10k type B thermistors are connected to these inputs.</p> <p>Pin 17, 19, 21, 23, 25, and 27 - sources <b>24V DC</b> which is current limited through an on board <b>200 mA</b> PTC Poly-Fuse. This is the high side of the pulse with modulated outputs, and low voltage inputs listed below.</p> <p>Pin 18, 20, 22, and 24 - Open collector PWM outputs, <b>100 mA</b> max each. Suitable for driving the opto-isolated PWM speed control inputs of EC motors.</p> <p>Pin 26, 28 - low voltage inputs, suitable for detecting dry contact closures with pins 25, 27 above.</p>	<p>Pin 29 - <b>0-10V DC</b> output, <b>5 mA</b> max, suitable for driving instrumentation inputs.</p> <p>Pin 30 - negative, common or ground side of the above <b>0-10V DC</b> output.</p> <p>Pin 31 - <b>0-10V DC</b> input, 10k Ohm impedance to ground or common.</p> <p>Pin 32 - negative, common or ground side of the above <b>0-10V DC</b> output.</p>

<p>Connector J11 factory programming only, Zilog ZDI microcontroller debug/programming interface</p>	
<p>Pin 1 - <b>3.3V DC</b>  Pin 2 - reset  Pin 3 - Gnd</p>	<p>Pin 4 - DBG input  Pin 5 - Gnd  Pin 6 - NC</p>

## HMI Configuration

**Options:** Allows the user to set HMI settings.

- English is the default language.
- The HMI dimmer factory setting is disabled.
- If the dimmer is enabled, the DIM delay (seconds) can be set.

**Factory Settings:** Allows the user to set or change the settings from the factory.

- Allows user to set number of Inputs, Outputs, Zones, and HMIs.
- Assign outputs allows user to assign outputs to zones.
- Zone Config allows the user to select a zone to set functions, override times, and logic for the inputs and schedule.
- Interlock Config allows the user to set interlock, if the interlock is enabled or disabled (default), and to set the interlock ON or OFF (default).

**Schedule Settings:** Allows the user to enable or disable ten different schedules. The user will be able to set day to day or weekly schedules, start and end times for selected zones.

**Holiday Settings:** Allows the user to set ten holiday settings. This will override the current schedule for the day, and month the parameters are set for.

**Schedule Override:** Allows the user to override the current schedule settings.

**Service Settings:** Allows user to monitor service features.

# HMI Menu Tree

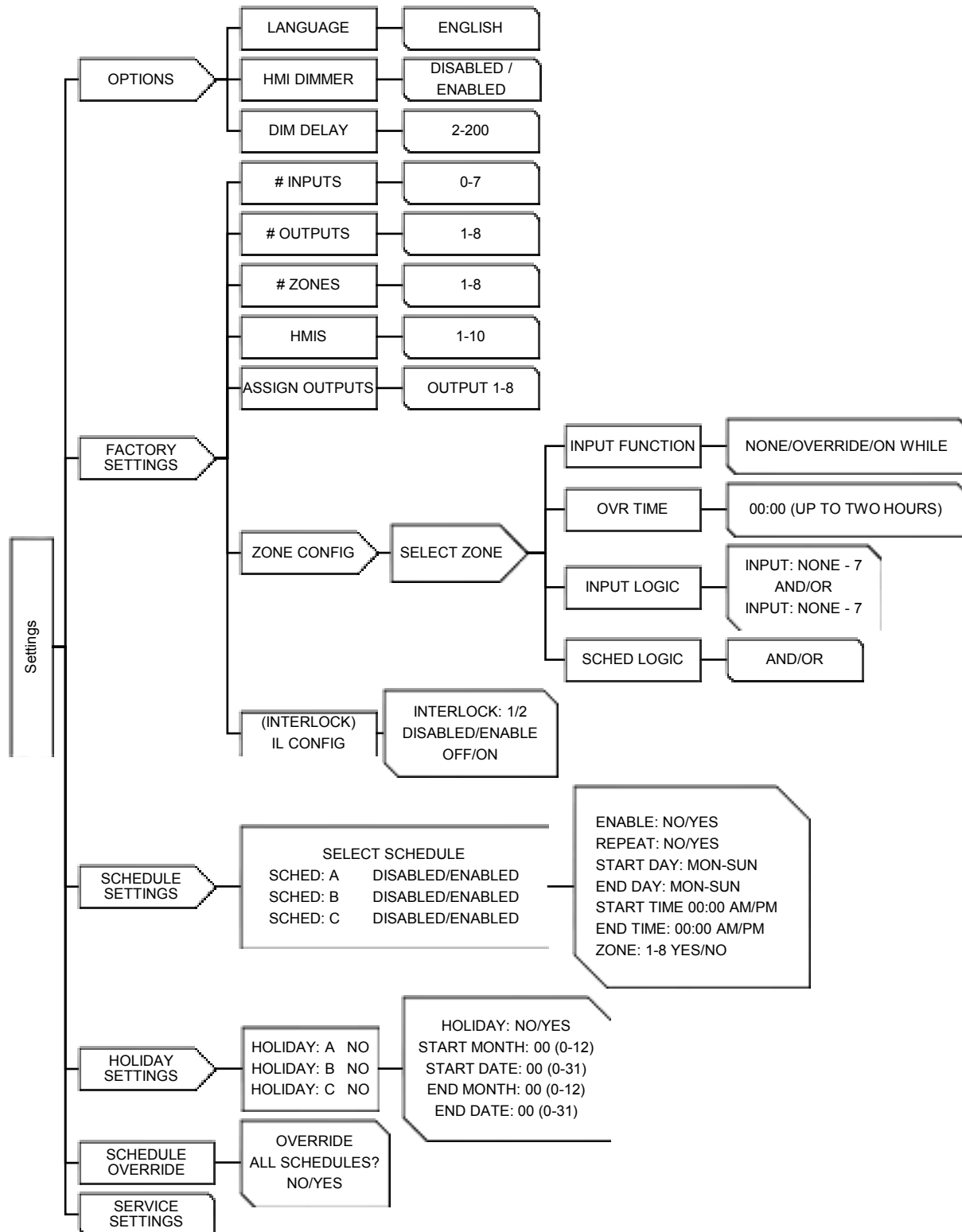

## Network

### Communication Module

The Communication Module, PN: **COM-01**, is included in all CASlink equipped panels. It obtains jobsite data from various jobsite components. Each component is connected to the Modbus Communication Network. This Communication wiring is either RS-485 shielded twisted pair wiring, or RJ45 CAT-5 Ethernet wiring.

### DDC Points

The Direct Digital Network (DDC) such as BACnet, or LonWorks allows the user access to specific commands. These are outlined in the [BACnet IP and BACnet MS/TP Points](#) (page 26) section.

All commands are activated by writing a “1” onto the present value of the object. Likewise, all commands are deactivated by writing a “0” onto the present value of the object.

Lights can be turned ON and OFF by the BMS or by the HMI, meaning that they can override each other. Lights will respond to any emergency conditions.

### BACnet

BACnet IP or BACnet MS/TP compatibility can be implemented on this package through a ProtoCessor, which is a BTL listed embedded Gateway configured to give a Building Management System (BMS) access to monitor and/or control a list of BACnet objects. The ProtoCessor is mounted and factory pre-wired inside the Electrical Control Panel. Field connections to the Building Management System are shown to the right.

The ProtoCessor is pre-configured at the factory to use the field protocol of the Building Management System in the specific jobsite. BACnet objects can only be accessed through the specified port and protocol.

1. Field Ethernet Connection for BACnet IP
2. Field RS485 Connection for BACnet MS/TP

Figure 16 – BACnet Wiring Reference

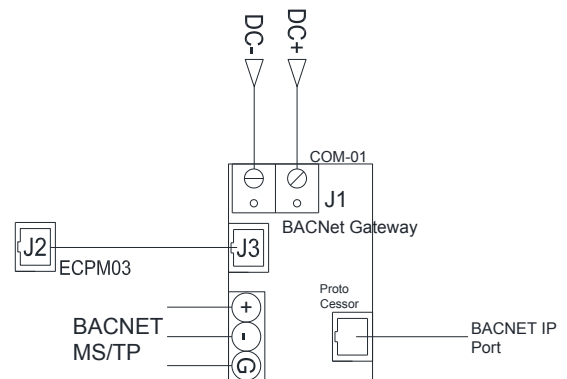
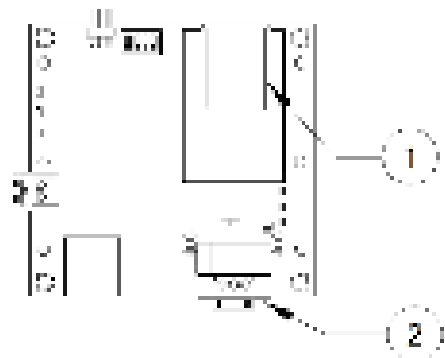

Figure 17 – BACnet Connections



### Changing Device Instance, MAC Address, Baud Rate

Some applications may require that the Processor have a specific Device Instance, the default device instance is 50,000. To change the Device Instance, you must access the Web Configurator by connecting a computer to the Ethernet port of the Processor. The computer used must be assigned a static IP address of 192.168.1.xxx and a subnet mask of 255.255.255.0.

To access the Web Configurator, type the IP address of the Processor in the URL of any web browser. The default IP address of the Processor is 192.168.1.24. The window shown in **Figure 18** should appear.

The MAC address and Baud Rate, used by BACNET MTSP, are editable. The MAC address default is 127 and the Baud Rate default is 38400.

**Figure 18 - Configuration Parameters Page**

Parameter Name	Parameter Description	Value
bac_device_id	<b>BACnet Device Instance</b> This sets the BACnet device instance. (1 - 4294967295)	50000 <input type="submit" value="Submit"/>
bac_mac_addr	<b>BACnet MTSP Mac Address</b> This sets the BACnet MTSP MAC address. (1 - 255)	127 <input type="submit" value="Submit"/>
bac_baud_rate	<b>BACnet MTSP Baud Rate</b> This sets the BACnet MTSP baud rate. (9600/14400/38400/76800)	38400 <input type="submit" value="Submit"/>
bac_max_master	<b>BACnet MTSP Max Master</b> This sets the BACnet MTSP max master. (1 - 255)	127 <input type="submit" value="Submit"/>
bac_cov_option	<b>BACnet COV</b> This enables or disables COV for the BACnet connection. Use COV_Enable to enable, Use COV_Disable to disable. (COV_Enable/COV_Disable)	COV_Enable <input type="submit" value="Submit"/>

If any changes are made, **click on the submit button for each individual change**. Each individual change will require the system to restart.

## Changing the IP Address

Some BACnet IP applications may require changing the IP address of the Protoceptor. In order to change the IP address, go to the internal server by typing the default IP address of the Protoceptor, 192.168.1.24, in the URL field of any web browser. The computer used must have a static IP address of 192.168.1.xxx. The window shown in **Figure 19** appears. Click on the “Diagnostics and Debugging” button on the lower right corner.

Click on “Setup” from the left hand side menu and select “Network Settings.” The window shown in **Figure 19** will appear. You can now modify the IP address to whatever is required in the application. Once the IP address has been modified, click on “Update IP Settings.”

**Figure 19 - Network Settings Page**

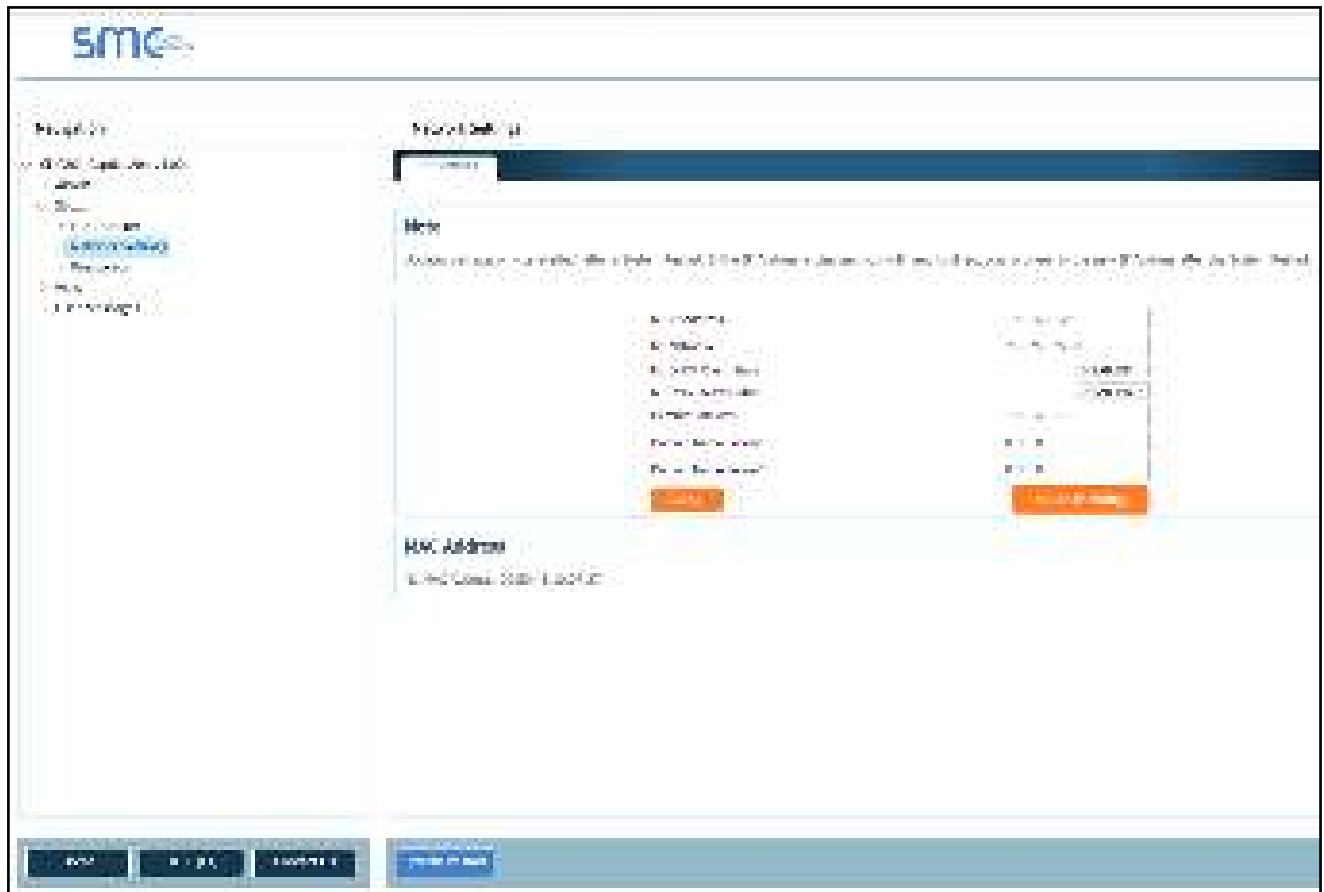

After you have updated the IP settings, you will be prompted to restart the system. You can do so by clicking on the “System Restart” button at the bottom of the screen. Any time after this, you will have to type the new IP address of the Protoceptor on the URL to gain access to the Web Configurator.

## BACnet IP and BACnet MS/TP Points

Object Name	BACnet Type	Description	Object ID
Zone 1 Override	Binary Value (BV)	1 = Zone ON for Override Time, 0 = OFF	1
Zone 2 Override	BV	2 = Zone ON for Override Time, 0 = OFF	2
Zone 3 Override	BV	3 = Zone ON for Override Time, 0 = OFF	3
Zone 4 Override	BV	4 = Zone ON for Override Time, 0 = OFF	4
Zone 5 Override	BV	5 = Zone ON for Override Time, 0 = OFF	5
Zone 6 Override	BV	6 = Zone ON for Override Time, 0 = OFF	6
Zone 7 Override	BV	7 = Zone ON for Override Time, 0 = OFF	7
Zone 8 Override	BV	8 = Zone ON for Override Time, 0 = OFF	8
Zone 1 Auto	BV	1 = Enable Board Control ON, 0 = OFF	9
Zone 2 Auto	BV	2 = Enable Board Control ON, 0 = OFF	10
Zone 3 Auto	BV	3 = Enable Board Control ON, 0 = OFF	11
Zone 4 Auto	BV	4 = Enable Board Control ON, 0 = OFF	12
Zone 5 Auto	BV	5 = Enable Board Control ON, 0 = OFF	13
Zone 6 Auto	BV	6 = Enable Board Control ON, 0 = OFF	14
Zone 7 Auto	BV	7 = Enable Board Control ON, 0 = OFF	15
Zone 8 Auto	BV	8 = Enable Board Control ON, 0 = OFF	16
Zone 1 Force Off	BV	1 Force Off Zone = ON, 0 = OFF	17
Zone 2 Force Off	BV	2 Force Off Zone = ON, 0 = OFF	18
Zone 3 Force Off	BV	3 Force Off Zone = ON, 0 = OFF	19
Zone 4 Force Off	BV	4 Force Off Zone = ON, 0 = OFF	20
Zone 5 Force Off	BV	5 Force Off Zone = ON, 0 = OFF	21
Zone 6 Force Off	BV	6 Force Off Zone = ON, 0 = OFF	22
Zone 7 Force Off	BV	7 Force Off Zone = ON, 0 = OFF	23
Zone 8 Force Off	BV	8 Force Off Zone = ON, 0 = OFF	24
Zone 1 Add Time	BV	1 Extend Zone Schedule by 2 Hours = ON, 0 = OFF	25
Zone 2 Add Time	BV	2 Extend Zone Schedule by 2 Hours = ON, 0 = OFF	26
Zone 3 Add Time	BV	3 Extend Zone Schedule by 2 Hours = ON, 0 = OFF	27
Zone 4 Add Time	BV	4 Extend Zone Schedule by 2 Hours = ON, 0 = OFF	28
Zone 5 Add Time	BV	5 Extend Zone Schedule by 2 Hours = ON, 0 = OFF	29
Zone 6 Add Time	BV	6 Extend Zone Schedule by 2 Hours = ON, 0 = OFF	30
Zone 7 Add Time	BV	7 Extend Zone Schedule by 2 Hours = ON, 0 = OFF	31
Zone 8 Add Time	BV	8 Extend Zone Schedule by 2 Hours = ON, 0 = OFF	32

Object Name	BACnet Type	Description	Object ID
OverrideAllowed Zone 1	BI	OverrideAllowed Zone 1	33
OverrideAllowed Zone 2	BI	OverrideAllowed Zone 2	34
OverrideAllowed Zone 3	BI	OverrideAllowed Zone 3	35
OverrideAllowed Zone 4	BI	OverrideAllowed Zone 4	36
OverrideAllowed Zone 5	BI	OverrideAllowed Zone 5	37
OverrideAllowed Zone 6	BI	OverrideAllowed Zone 6	38
OverrideAllowed Zone 7	BI	OverrideAllowed Zone 7	39
OverrideAllowed Zone 8	BI	OverrideAllowed Zone 8	40
AutoAllowed Zone 1	BI	AutoAllowed Zone 1	41
AutoAllowed Zone 2	BI	AutoAllowed Zone 2	42
AutoAllowed Zone 3	BI	AutoAllowed Zone 3	43
AutoAllowed Zone 4	BI	AutoAllowed Zone 4	44
AutoAllowed Zone 5	BI	AutoAllowed Zone 5	45
AutoAllowed Zone 6	BI	AutoAllowed Zone 6	46
AutoAllowed Zone 7	BI	AutoAllowed Zone 7	47
AutoAllowed Zone 8	BI	AutoAllowed Zone 8	48
ForceOFFAllowed Zone 1	BI	ForceOFFAllowed Zone 1	49
ForceOFFAllowed Zone 2	BI	ForceOFFAllowed Zone 2	50
ForceOFFAllowed Zone 3	BI	ForceOFFAllowed Zone 3	51
ForceOFFAllowed Zone 4	BI	ForceOFFAllowed Zone 4	52
ForceOFFAllowed Zone 5	BI	ForceOFFAllowed Zone 5	53
ForceOFFAllowed Zone 6	BI	ForceOFFAllowed Zone 6	54
ForceOFFAllowed Zone 7	BI	ForceOFFAllowed Zone 7	55
ForceOFFAllowed Zone 8	BI	ForceOFFAllowed Zone 8	56
AddTimeAllowed Zone 1	BI	AddTimeAllowed Zone 1	57
AddTimeAllowed Zone 2	BI	AddTimeAllowed Zone 2	58
AddTimeAllowed Zone 3	BI	AddTimeAllowed Zone 3	59
AddTimeAllowed Zone 4	BI	AddTimeAllowed Zone 4	60
AddTimeAllowed Zone 5	BI	AddTimeAllowed Zone 5	61
AddTimeAllowed Zone 6	BI	AddTimeAllowed Zone 6	62
AddTimeAllowed Zone 7	BI	AddTimeAllowed Zone 7	63
AddTimeAllowed Zone 8	BI	AddTimeAllowed Zone 8	64

Object Name	BACnet Type	Description	Object ID
Board Fuse Blown	Binary Input (BI)	Fuse = OA, 0 = OFF	65
Check Panel Switch 1	BI	1 = Panel Switch Off, 0 = OFF	66
Check Panel Switch 2	BI	2 = Panel Switch Off, 0 = OFF	67
Check Panel Switch 3	BI	3 = Panel Switch Off, 0 = OFF	68
Check Panel Switch 4	BI	4 = Panel Switch Off, 0 = OFF	69
Check Panel Switch 5	BI	5 = Panel Switch Off, 0 = OFF	70
Check Panel Switch 6	BI	6 = Panel Switch Off, 0 = OFF	71
Check Panel Switch 7	BI	7 = Panel Switch Off, 0 = OFF	72
Check Panel Switch 8	BI	8 = Panel Switch Off, 0 = OFF	73
Output On by Panel Switch 1	BI	1 = Panel Switch Manually On, 0 = OFF	74
Output On by Panel Switch 2	BI	2 = Panel Switch Manually On, 0 = OFF	75
Output On by Panel Switch 3	BI	3 = Panel Switch Manually On, 0 = OFF	76
Output On by Panel Switch 4	BI	4 = Panel Switch Manually On, 0 = OFF	77
Output On by Panel Switch 5	BI	5 = Panel Switch Manually On, 0 = OFF	78
Output On by Panel Switch 6	BI	6 = Panel Switch Manually On, 0 = OFF	79
Output On by Panel Switch 7	BI	7 = Panel Switch Manually On, 0 = OFF	80
Output On by Panel Switch 8	BI	8 = Panel Switch Manually On, 0 = OFF	81

## LonWorks

LonWorks compatibility can be implemented on control packages through the ProtoNode, a LonMark certified external Gateway configured to give a Building Management System access to monitor and/or control a list of Network Variables. The ProtoNode is mounted and factory pre-wired inside the Electrical Control Panel. Field connections to the Building Management System is shown.

Figure 20 – LonWorks Adapter

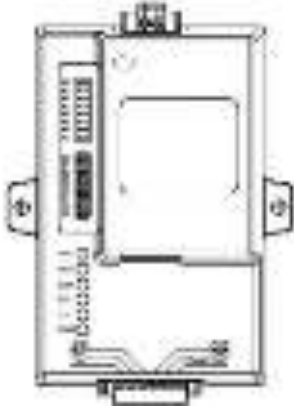
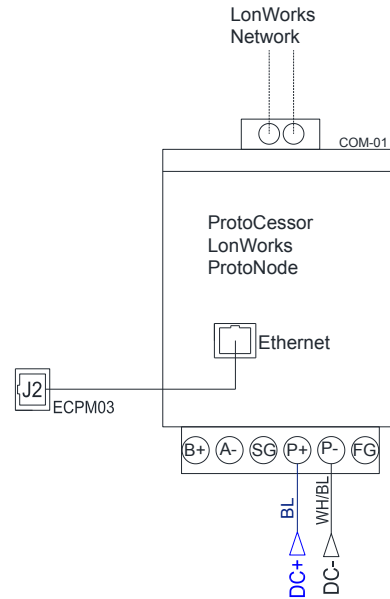

Figure 21 – LonWorks Wiring Reference



## LonWorks Points

SNVT	LON_Function	SNVT_Type	Index
nvoOverrideZ1	NVUOIMT	SNVT_count	0
nvoOverrideZ2	NVUOIMT	SNVT_count	1
nvoOverrideZ3	NVUOIMT	SNVT_count	2
nvoOverrideZ4	NVUOIMT	SNVT_count	3
nvoOverrideZ5	NVUOIMT	SNVT_count	4
nvoOverrideZ6	NVUOIMT	SNVT_count	5
nvoOverrideZ7	NVUOIMT	SNVT_count	6
nvoOverrideZ8	NVUOIMT	SNVT_count	7
nvoAutoZ1	NVUOIMT	SNVT_count	8
nvoAutoZ2	NVUOIMT	SNVT_count	9
nvoAutoZ3	NVUOIMT	SNVT_count	10
nvoAutoZ4	NVUOIMT	SNVT_count	11
nvoAutoZ5	NVUOIMT	SNVT_count	12
nvoAutoZ6	NVUOIMT	SNVT_count	13
nvoAutoZ7	NVUOIMT	SNVT_count	14
nvoAutoZ8	NVUOIMT	SNVT_count	15
nvoForceOFFZ1	NVUOIMT	SNVT_count	16
nvoForceOFFZ2	NVUOIMT	SNVT_count	17
nvoForceOFFZ3	NVUOIMT	SNVT_count	18
nvoForceOFFZ4	NVUOIMT	SNVT_count	19
nvoForceOFFZ5	NVUOIMT	SNVT_count	20
nvoForceOFFZ6	NVUOIMT	SNVT_count	21
nvoForceOFFZ7	NVUOIMT	SNVT_count	22
nvoForceOFFZ8	NVUOIMT	SNVT_count	23
nvoAddTimeZ1	NVUOIMT	SNVT_count	24
nvoAddTimeZ2	NVUOIMT	SNVT_count	25
nvoAddTimeZ3	NVUOIMT	SNVT_count	26
nvoAddTimeZ4	NVUOIMT	SNVT_count	27
nvoAddTimeZ5	NVUOIMT	SNVT_count	28
nvoAddTimeZ6	NVUOIMT	SNVT_count	29
nvoAddTimeZ7	NVUOIMT	SNVT_count	30
nvoAddTimeZ8	NVUOIMT	SNVT_count	31
nvoCanOverrideZ1	NVUOIMT	SNVT_count	32
nvoCanOverrideZ2	NVUOIMT	SNVT_count	33
nvoCanOverrideZ3	NVUOIMT	SNVT_count	34
nvoCanOverrideZ4	NVUOIMT	SNVT_count	35
nvoCanOverrideZ5	NVUOIMT	SNVT_count	36
nvoCanOverrideZ6	NVUOIMT	SNVT_count	37
nvoCanOverrideZ7	NVUOIMT	SNVT_count	38
nvoCanOverrideZ8	NVUOIMT	SNVT_count	39

SNVT	LON_Function	SNVT_Type	Index
nvoCanAutoZ1	NVUOIMT	SNVT_count	40
nvoCanAutoZ2	NVUOIMT	SNVT_count	41
nvoCanAutoZ3	NVUOIMT	SNVT_count	42
nvoCanAutoZ4	NVUOIMT	SNVT_count	43
nvoCanAutoZ5	NVUOIMT	SNVT_count	44
nvoCanAutoZ6	NVUOIMT	SNVT_count	45
nvoCanAutoZ7	NVUOIMT	SNVT_count	46
nvoCanAutoZ8	NVUOIMT	SNVT_count	47
nvoCanForceOFFZ1	NVUOIMT	SNVT_count	48
nvoCanForceOFFZ2	NVUOIMT	SNVT_count	49
nvoCanForceOFFZ3	NVUOIMT	SNVT_count	50
nvoCanForceOFFZ4	NVUOIMT	SNVT_count	51
nvoCanForceOFFZ5	NVUOIMT	SNVT_count	52
nvoCanForceOFFZ6	NVUOIMT	SNVT_count	53
nvoCanForceOFFZ7	NVUOIMT	SNVT_count	54
nvoCanForceOFFZ8	NVUOIMT	SNVT_count	55
nvoCanAddTimeZ1	NVUOIMT	SNVT_count	56
nvoCanAddTimeZ2	NVUOIMT	SNVT_count	57
nvoCanAddTimeZ3	NVUOIMT	SNVT_count	58
nvoCanAddTimeZ4	NVUOIMT	SNVT_count	59
nvoCanAddTimeZ5	NVUOIMT	SNVT_count	60
nvoCanAddTimeZ6	NVUOIMT	SNVT_count	61
nvoCanAddTimeZ7	NVUOIMT	SNVT_count	62
nvoCanAddTimeZ8	NVUOIMT	SNVT_count	63
nvoBoardFuseFit	NVUOIMT	SNVT_count	64
nvoCheckPanelSw1	NVUOIMT	SNVT_count	65
nvoCheckPanelSw2	NVUOIMT	SNVT_count	66
nvoCheckPanelSw3	NVUOIMT	SNVT_count	67
nvoCheckPanelSw4	NVUOIMT	SNVT_count	68
nvoCheckPanelSw5	NVUOIMT	SNVT_count	69
nvoCheckPanelSw6	NVUOIMT	SNVT_count	70
nvoCheckPanelSw7	NVUOIMT	SNVT_count	71
nvoCheckPanelSw8	NVUOIMT	SNVT_count	72
nvoOutONbySw1	NVUOIMT	SNVT_count	73
nvoOutONbySw2	NVUOIMT	SNVT_count	74
nvoOutONbySw3	NVUOIMT	SNVT_count	75
nvoOutONbySw4	NVUOIMT	SNVT_count	76
nvoOutONbySw5	NVUOIMT	SNVT_count	77
nvoOutONbySw6	NVUOIMT	SNVT_count	78
nvoOutONbySw7	NVUOIMT	SNVT_count	79
nvoOutONbySw8	NVUOIMT	SNVT_count	80

SNVT	LON_Function	SNVT_Type	Index
nviOverrideZ1	NVUI	SNVT_count	81
nviOverrideZ2	NVUI	SNVT_count	82
nviOverrideZ3	NVUI	SNVT_count	83
nviOverrideZ4	NVUI	SNVT_count	84
nviOverrideZ5	NVUI	SNVT_count	85
nviOverrideZ6	NVUI	SNVT_count	86
nviOverrideZ7	NVUI	SNVT_count	87
nviOverrideZ8	NVUI	SNVT_count	88
nviAutoZ1	NVUI	SNVT_count	89
nviAutoZ2	NVUI	SNVT_count	90
nviAutoZ3	NVUI	SNVT_count	91
nviAutoZ4	NVUI	SNVT_count	92
nviAutoZ5	NVUI	SNVT_count	93
nviAutoZ6	NVUI	SNVT_count	94
nviAutoZ7	NVUI	SNVT_count	95
nviAutoZ8	NVUI	SNVT_count	96
nviForceOFFZ1	NVUI	SNVT_count	97
nviForceOFFZ2	NVUI	SNVT_count	98
nviForceOFFZ3	NVUI	SNVT_count	99
nviForceOFFZ4	NVUI	SNVT_count	100
nviForceOFFZ5	NVUI	SNVT_count	101
nviForceOFFZ6	NVUI	SNVT_count	102
nviForceOFFZ7	NVUI	SNVT_count	103
nviForceOFFZ8	NVUI	SNVT_count	104
nviAddTimeZ1	NVUI	SNVT_count	105
nviAddTimeZ2	NVUI	SNVT_count	106
nviAddTimeZ3	NVUI	SNVT_count	107
nviAddTimeZ4	NVUI	SNVT_count	108
nviAddTimeZ5	NVUI	SNVT_count	109
nviAddTimeZ6	NVUI	SNVT_count	110
nviAddTimeZ7	NVUI	SNVT_count	111
nviAddTimeZ8	NVUI	SNVT_count	112

# TROUBLESHOOTING

## HMI Fault / Warnings

Problem	Potential Cause	Corrective Action
Is Fuse Blown	Excessive Current	<ul style="list-style-type: none"> <li>• Check the fuse located on the ECPM03 board.</li> <li>• Check the system for a short circuit.</li> <li>• Verify load is below 10 amps. Replace fuse</li> </ul>
Contactor Mismatch	Incorrect wiring	Check wiring to the contactor
	Incorrect panel switch setting	Check the internal panel switches are set properly. See <a href="#">Component Description</a> (page 8)
Communications Fault Check configuration	Additional HMI is not communicating	<ul style="list-style-type: none"> <li>• Verify the # of HMIs is set correctly</li> <li>• Check cable connections between HMIs</li> </ul>
Panel Switch “x” Manual	Panel switch is in the manual position, when the lighting logic is set to be OFF.	Correct switch position in the Lighting Control Panel.
Panel Switch “x” OFF	Panel switch is in the OFF position, when the lighting logic is set to be ON.	Correct switch position in the Lighting Control Panel.

## Troubleshooting Chart

Problem	Potential Cause	Corrective Action
Unit not turning on lights	Power issue	Check for voltage at H1 and N1 on the terminal block. There should be <b>120V AC</b>
	Loose wiring	Check wiring to terminal block
	Incorrect panel switch wiring / position	<ul style="list-style-type: none"> <li>Check wiring to the Auto/Manual switches.</li> <li>Check the internal panel switches are set properly.</li> </ul>
	Missing voltage at board	Check for voltage between J6 pin 1 and pin 14. There should be <b>24V DC</b>
	Contactors	<ul style="list-style-type: none"> <li>Check wiring to the contactor</li> <li>Verify contactor coil <a href="#">Component Check/Testing</a> (page 35)</li> </ul>
HMI screen is blank	Loose connection	<ul style="list-style-type: none"> <li>Check the connection between the HMI, and the ECPM03 board connection J4</li> <li>If more than one HMI is used, verify they are connected together. Make sure the last HMI has an end of line resistor installed</li> </ul>
	Power Supply	See <a href="#">Component Check/Testing</a> (page 35)
Lighting not working properly	Incorrect control settings	<ul style="list-style-type: none"> <li>Verify the lighting control is set correctly</li> <li>Verify inputs, and zones are set properly</li> </ul>
	Incorrect panel switch wiring / position	<ul style="list-style-type: none"> <li>Check wiring to the Auto/Manual switches.</li> <li>Check the internal panel switches are set properly.</li> </ul>
	Loose/connection wiring	<ul style="list-style-type: none"> <li>Check wiring to terminal block, contactors</li> <li>Check connections to the ECPM03 board</li> </ul>
	Contactors	<ul style="list-style-type: none"> <li>Check wiring to the contactor</li> <li>Verify contactor coil</li> <li>See <a href="#">Component Check/Testing</a> (page 35)</li> </ul>
	Possible sensor failure	<ul style="list-style-type: none"> <li>Sensor not configured properly</li> <li>Sensor wiring issue</li> <li>Defective sensor</li> </ul>
	Issue with fixture or bulb	Check for issues with light fixture or bulb

## Component Check/Testing

### Contactors (C-x)

1. Make sure all connections are secure, and connected properly. Verify connections to the schematic.
2. Check for voltage at the contactor when the lighting control is ON:
  - There should be approximately **120V AC** from terminal A1 to ground.
  - There should be approximately **120V AC** from terminal A1 to terminal A2.
    - If the voltage reading is incorrect when checking terminal A1 to ground, check the switch input and wiring.
    - If the voltage reading is incorrect when checking terminal A1 to terminal A2, continue to step 3.
    - If the voltage reading is correct, verify the field wiring to the contactor and the light source.
3. Turn the Auto/Off/Manual switch for that contactor to the off position. Verify the coil resistance from terminal A1 to terminal A2. There should be a nominal resistance value. The ohm value will vary depending on the contactor.
  - If the resistance value is **0 ohms** or **OL** (Infinite), the coil has failed. Replace the contactor.
  - If the resistance reading is correct, verify the field wiring to the contactor and the light source.

Figure 22 - Contactor



Figure 23 – Contactor Wiring Reference

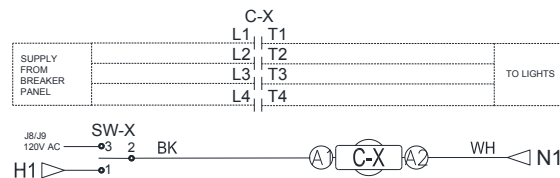

### Power Supply (PS-01)

1. Make sure all connections are secure, and connected properly. Verify connections to the schematic.
2. Check for DC voltage from the power supply between V- to V+ when the unit is ON. There should be approximately **24V DC**.
3. Check for AC voltage from the power supply between N to L when the unit is ON. There should be approximately **120V AC**.
  - If any of the readings are incorrect, check the wiring for open or short circuits. Try adjusting the output voltage, if the DC voltage is incorrect.
  - If all of the wiring is correct, the power supply may have failed.

Figure 24 – Power Supply Wiring Reference

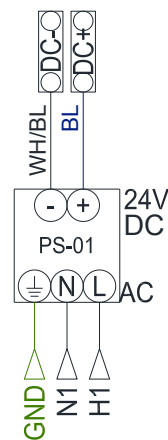

# MAINTENANCE

To ensure trouble free operation of this control, the manufacturer suggests following these guidelines. Most problems associated with unit failures are directly related to poor service and maintenance.

Please record any maintenance or service performed on this equipment in the documentation section located at the end of this manual.

**WARNING: DO NOT ATTEMPT MAINTENANCE ON THIS CONTROL UNTIL THE ELECTRICAL SUPPLY HAS BEEN COMPLETELY DISCONNECTED, LOCKED OUT AND TAGGED OUT.**

## General Maintenance

1. Control enclosure should be kept clean and free from any grease or dirt build-up.
2. All fasteners should be checked for tightness each time maintenance checks are preformed prior to restarting unit.
3. Control enclosure door panel should be securely closed after maintenance to prevent tampering or electrical shock.
4. Real Time Clock (RTC) battery should be replaced every 9-10 Years. Use CR2032 or equivalent.

**Factory Service Department  
Phone: 1-866-784-6900  
Fax: 1-919-554-9374**