



**MSG<sup>AIR</sup>**

OPERATIONS,  
INSTALLATION AND  
MAINTENANCE MANUAL



**MEDELEC**

## CONTENTS

<b>1</b>	<b>Summary .....</b>	<b>7</b>
1.1	General Construction.....	7
1.2	Standards and specifications .....	7
1.3	Operating conditions.....	8
1.3.1	Normal operating conditions.....	8
1.3.2	Special operating conditions.....	8
1.4	Safety Features.....	9
<b>2</b>	<b>Technical data .....</b>	<b>9</b>
2.1	Electrical data .....	9
2.2	Dimensions and weights.....	10
<b>3</b>	<b>General Construction .....</b>	<b>11</b>
3.1	Basic structure and variants.....	11
3.1.1	Busbar compartment.....	12
3.1.2	Circuit breaker compartment.....	12
3.1.3	Cable connection/VT compartment.....	13
3.1.4	Low Voltage Compartment .....	13
3.2	Withdrawable and fixed equipment .....	14
3.2.1	Circuit Breaker .....	14
3.2.2	Voltage transformers.....	17
3.2.3	Current transformers .....	17
3.2.4	Voltage Detection System .....	18
3.2.5	Earthing switch.....	18
3.3	Enclosure and partitioning.....	19
3.4	Ventilation of the panels.....	19
3.5	The exhaust gas compartment.....	20
3.6	The gas duct.....	21
3.7	Typical Units.....	22
3.7.1	Incoming panel .....	22
3.7.2	Outgoing panel.....	23
3.7.3	Busbar Tie (Bustie).....	24
3.7.4	Busbar riser .....	26
3.7.5	Measurement panel (Client-specific optional).....	27
<b>4</b>	<b>Interlocks.....</b>	<b>28</b>
4.1	Interlock Cross reference table.....	28
4.1.1	Withdrawable equipment – racking with door open interlock.....	30
4.1.2	Circuit breaker – racking interlock.....	30
4.1.3	Circuit breaker – CLOSE interlock.....	30
4.1.4	Circuit breaker – CLOSE lock.....	31
4.1.5	Withdrawable equipment - latching handles .....	31
4.1.6	Socket board interlock .....	32
4.1.7	Circuit breaker secondary plug connector coding .....	32
4.1.8	Withdrawable equipment – door interlock.....	33
4.1.9	Earthing switch interlocks .....	34
4.1.10	Door Interlocks.....	35
<b>5</b>	<b>Packing Transport and Storage .....</b>	<b>38</b>
5.1	Condition on delivery .....	38

5.2	Packing.....	38
5.3	Transport.....	39
5.4	Control on receipt.....	39
5.5	Intermediate storage .....	40
5.6	Handling.....	40
5.6.1	Handling the Switchgear .....	40
5.6.2	Unpacking and switchboard handling.....	41
5.6.3	Handling the removable parts.....	42
<b>6</b>	<b>Installation .....</b>	<b>43</b>
6.1	Installation - General Information.....	43
6.2	Foundation and switchgear erection.....	44
6.2.1	Tightening torque table .....	44
6.2.2	Foundation details.....	44
6.2.3	Fixing with unistruts foundation Channels.....	46
6.2.4	Fixing with anchoring bolts (Expanding type bolts) .....	47
6.2.5	Position and fixing the units on the foundation .....	47
6.3	Main Busbar Assembly .....	49
6.4	Unit earthing.....	53
6.5	Installation of Gas Compartment.....	54
6.6	The gas duct.....	56
6.7	Connection of Inter-unit auxiliary wiring (Bus-wiring) .....	57
6.8	Connecting the auxiliary multicore cables.....	57
6.8.1	Front bottom entry.....	57
6.8.1	Rear bottom entry .....	58
6.8.2	Low voltage wiring trough.....	58
6.9	Power cable termination .....	59
6.9.1	Cable supports and grommets for single core cables.....	61
6.9.2	Cable gland for 3 core cables.....	62
6.10	Installation of the decorative end covers.....	63
6.11	Installing the tool rack.....	67
6.12	Aligning the door racking access hole to the circuit breaker drive .....	67
6.13	Final check .....	68
6.14	Circuit name label.....	68
6.15	Extending the switchboard.....	68
<b>7</b>	<b>Operation .....</b>	<b>69</b>
7.1	Operating Accessories .....	69
7.2	Circuit breaker positions.....	70
7.2.1	Removed position.....	70
7.2.2	Isolated/ test position.....	71
7.2.3	Service Position .....	71
7.3	Inserting the Circuit breaker into the panel from the removed position.....	72
7.4	Racking the circuit breaker from the isolated/test position to the service position .....	74
7.5	Withdrawal from service to isolate/test position .....	75
7.6	Removal of the circuit breaker from the panel.....	75
7.7	Padlocking the shutters.....	76
7.8	Operating the circuit breaker in the isolated/test position with door open .....	76
7.8.1	Spring charging .....	76
7.8.2	Circuit breaker closing.....	77
7.8.3	Circuit breaker opening.....	77
7.9	Operating the circuit breaker in the service position with door closed.....	77
7.9.1	Manual spring charging.....	78
7.9.2	Manual switching ON with door closed.....	78
7.9.3	Manual switching OFF with door closed.....	79
7.10	Electrical Operation.....	79

---

7.10.1	Electrical spring charging.....	79
7.10.2	Switching ON.....	80
7.10.3	Switching OFF.....	80
7.11	VT Compartment.....	81
7.11.1	Withdrawable VT.....	81
7.12	Earthing.....	83
7.12.1	Switching ON the earthing switch.....	84
7.12.2	Switching OFF the earthing switch.....	85
7.12.3	Optional Voltage Detection System VDS.....	85
<b>8</b>	<b>Commissioning checks and test programme.....</b>	<b>86</b>
8.1	General checks.....	86
8.2	Electrical tests.....	87
8.3	Mechanical Tests.....	87
8.4	Recording.....	88
8.5	Check Lists.....	89
8.6	Counter Recording.....	90
<b>9</b>	<b>General Maintenance.....</b>	<b>91</b>
9.1	Intervals for inspection, servicing and repairs.....	92
9.2	Inspection.....	92
9.3	Servicing.....	93
9.3.1	Maintenance in busbar compartment.....	94
9.3.2	Maintenance in cable compartment.....	95
9.3.3	Maintenance in circuit breaker compartment.....	98
9.3.4	Checking correct operation of the protection relay.....	99
9.3.5	Cleaning and checking the auxiliary connections.....	99
9.4	Repairs.....	100
9.4.1	Switchgear in general.....	100
9.5	Testing interlock conditions.....	100
9.6	Spare parts, auxiliary materials and lubricants.....	100
9.6.1	Spare parts.....	100
9.6.2	Accessories, Auxiliary materials and lubricants.....	101

## Safety Warning

- Only install switchgear and/or switchboards in closed rooms designed and constructed specifically for electrical equipment.
- Ensure that installation, operation and maintenance are carried out by trained and qualified personnel only.
- Fully comply with the legally recognized standards (IEC or local), the local electrical utility and the applicable safety at work regulations.
- Observe the relevant information in this instruction manual for all actions involving operation and maintenance of the **MSG™** switchgear.
- Before working on the Switchgear it is necessary for the operator to ensure that it has been safely disconnected from electrical supplies and that the necessary safety earths have been fitted and a suitable permit to work issued.
- To assist in its safe operation, the equipment is fitted with padlocking facilities which shall be applied as appropriate.
- Ensure that the operating conditions do not exceed the specified data.
- Keep the instruction manual accessible to all personnel involved in installation, operation and maintenance.
- Operations not included in the manual must be carried out by or under the supervision of Medelec Switchgear Ltd.
- This manual uses certain terms and symbols to warn about dangers or provide information:



**WARNING** – Warns about dangerous electrical voltage or contact with voltage.



**CAUTION** – Warns about risk of injury.



**NOTE** - Gives important information to avoid damage to equipment

## General Instructions

Medelec Switchgear Ltd has done its utmost to inform users as accurately and as fully as possible concerning any dangers involved in using the equipment. Users are responsible for supervising the implementation of the instructions contained in this manual.

Before commencing work and after the completion of work any control switches shall be left in the appropriate positions.

Should the operator require any guidance or advice regarding the equipment this can be obtained by contacting Medelec Switchgear Ltd.

Our policy is one of continuous product development and the right is reserved to supply equipment, which may vary slightly from that described.

# 1 Summary

## 1.1 General Construction

**MSG** is a three-phase, metal-clad, air insulated, internal arc certified switchgear of modular construction. All the units are factory assembled, type-tested and suitable for indoor applications up to 12kV. The units are designed as modules and are fitted with a single busbar system. The withdrawable parts are equipped with vacuum circuit breakers. Existing units are easily extendable from both sides if the site permits.

All the unit compartments have metal segregations between them and the live parts are insulated in air.

The cubicles are all factory-cabled. The installation requires only the external power and auxiliary connections and the wiring between the various units, together with the assembly of the main busbar, the exhaust gas Compartment on top of each unit and the decorative end covers.

The normal service operations are performed from the switch-board front with all the doors closed. Only maintenance and replacement of spare parts require opening of the front doors. All functions are easily accessible by the operator.

**MSG** is for use on distribution networks having the highest system voltage up to 12kV, a short circuit current rating up to 31.5kA, a maximum full load current of 2000A and a lightning impulse level up to 75 kVp (BIL).

## 1.2 Standards and specifications

**MSG** switchgear panels comply with the standards and specifications for factory-assembled, metal-enclosed and type tested high voltage switchgear to IEC 62271-1 and -200.

The switchgear panels have the following degrees of protection: IP4X for the enclosure and IP2X for the partitions to IEC 60529.

**MSG** switchboards are arc-proof and comply with IEC 62271 Standards Accessibility Class AFLR.

The components used comply with standards:

- IEC 62271-100: High-voltage alternating current circuit breakers
- IEC 62271-102: Alternating current disconnector and earthing switches
- IEC 61869-2: Instrument transformers - part 2: Current transformers
- IEC 61869-3: Instrument transformers - part 3: Voltage transformers
- IEC 62271-206 For the voltage presence indication system

## 1.3 Operating conditions

### 1.3.1 Normal operating conditions

The switchgear is suitable for normal operating conditions for indoor switchgear and switchboards in accordance with IEC 60694. The installation may only be operated if the area complies with the requirements of the IEC 62271-1 standard. (See also paragraph 6.1) Additional conditions may also apply. These are laid down in the operating instructions.

The following limit values, among others, apply:

Ambient temperature:

Maximum +40 °C

Maximum 24 h average +35 °C

Minimum -5 °C

The maximum site altitude is 1000 m above sea level.

### 1.3.2 Special operating conditions

Special operating conditions must be discussed with the manufacturer in advance, for example:

- At site altitudes above 1000 m, the effects of the reduction in dielectric strength of the air on the insulation level must be taken into account.
- Increased ambient temperatures will limit the current carrying capacity of the busbars. Heat dissipation in the switchgear panel can be assisted by fitting additional ventilation facilities.

All units are equipped with self-regulating heaters to eliminate the possibility of moisture condensation due to high humidity and/or major rapid temperature fluctuations.

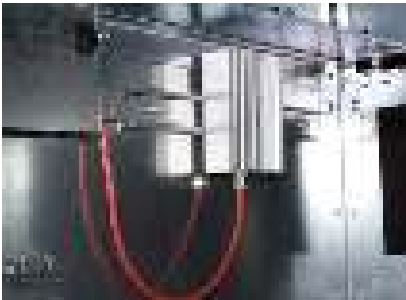

## 1.4 Safety Features

In general it will not be necessary to take special safety measures when operating the switchgear. It is advisable, however, to wear suitable ear protection when there is repeated switching.

The switchgear is provided with the following safety features:

- A steel sheet enclosure to protect against contact with live components.
- Compartments with earthed steel walls.
- Positively driven metallic shutters shielding live parts when a withdrawable part is withdrawn or removed.
- Internal arc classification testing has been conducted and an exhaust gas Compartment provided to allow the safe exhaust of gases outside of the switch room through a gas duct.
- Mechanical and electrical interlocks to prevent unintentional switching.
- Provision for locking or padlocking on the circuit breakers, earthing switches and shutters.
- Separation between circuit breaker, cable and busbar Compartments.
- Visible indication of the earthing switch status.
- Special equipment intended for the earthing of cables and busbars.
- A continuous earthing bar extending the full length of the installation.
- Locks on panel doors.
- Warnings on equipment to alert personnel of possible dangers.

## 2 Technical data

### 2.1 Electrical data

Rated voltage	kV	12
Rated power frequency withstand voltage	kV	28
Rated lightning impulse withstand voltage	kV	75
Rated frequency	Hz	50/60
Rated current of busbars	A	...2000
Rated current of circuit breaker branches	A	...2000
Rated peak withstand current	kA	...80
Rated short-circuit breaking current of circuit breaker	kA	...31.5
Rated duration of short-circuit current	s	3

## 2.2 Dimensions and weights

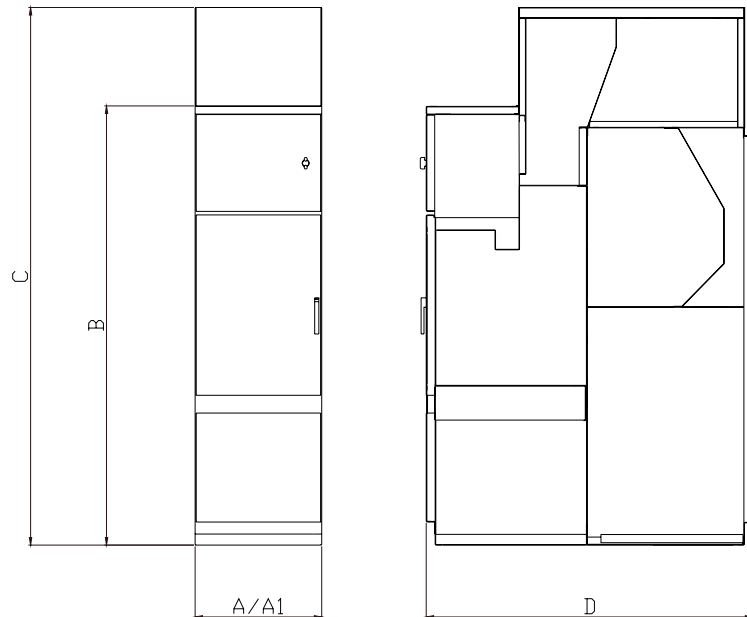

Rated Voltage (Panel width)	Rated Current	Dimension (mm)				Weight (kg)
		A/A1	B	C	D	
12kV (600mm)	...1250A	600	2050	2510	1550	500
12kV (750mm)	2000A	750	2050	2510	1550	570



**CAUTION:** The weights indicated are approximate and do not include contract variable non-standard components or apparatus.

### 3 General Construction

#### 3.1 Basic structure and variants

The **MSG** panel with withdrawable vacuum circuit breaker is divided into circuit breaker compartment, busbar compartment, cable compartment and low voltage compartment for the control and protection equipment. The **MSG** also contains other compartments used for the channelling of gases in the case of an internal arc, routing of auxiliary wiring between units and also segregation of the withdrawable VT's.

For busbar isolation, two panels are necessary, the Bustie with the withdrawable circuit breaker part and a bus riser panel. The **MSG** can also be supplied with optional busbar metering and earthing.

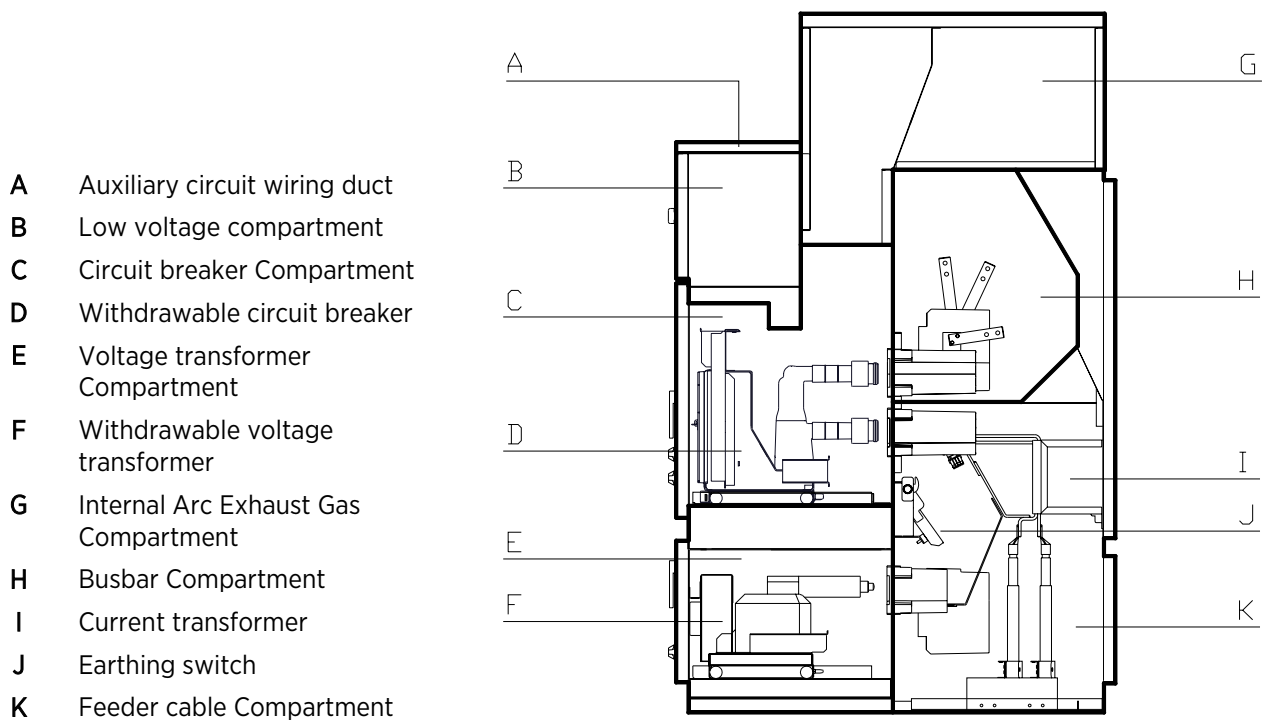

### 3.1.1 Busbar compartment



The busbars have a flat cross-section made of copper and are laid in sections from panel to panel. They are held by flat branch conductors and no special connection clamps are needed. No insulation is required. The busbar compartment is accessible from the rear of the panel or from the top depending on the installation layout. When accessed from the rear top cover, a perforated plate segregates the accessed area from the cable compartment thus providing LSC2B partitioning.

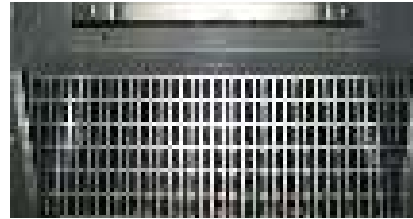

### 3.1.2 Circuit breaker compartment



The circuit breaker compartment contains all the necessary equipment for the operation of the withdrawable part and the panel. Like the busbar compartment, it is metallically partitioned on all sides. The metal shutters, covering the fixed contacts provide the necessary separation from the main contacts. These are opened by means of brackets mounted on the withdrawable circuit breaker when inserting into the service position, and are closed when the latter is removed.

In the isolated/test position, the withdrawable part is still completely inside the panel with the door closed. The ON/OFF pushbutton located on the circuit breaker, and the mechanical indicators for OPEN/CLOSE and CHARGED/DISCHARGED can be observed through an inspection window if the circuit breaker is in service position.

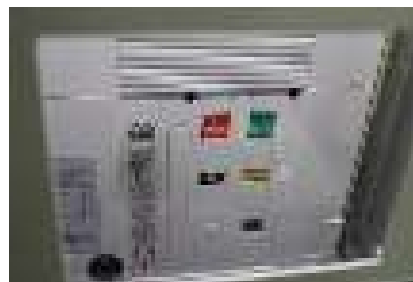

All operations, including racking, charging and switching, are carried out with the doors closed. The socket for the control wiring is plugged in the circuit breaker compartment and mechanically interlocked with the Circuit Breaker racking.

The CB door also includes a circuit single line diagram.

### 3.1.3 Cable connection/VT compartment



The **MSG** can be supplied either for the connection of single core cables or 3 core cables with the trifurcation inside the cable compartment. In the former case, cables are supported by cable clamps whilst in the latter a cable gland located underneath the cable compartment is provided.



The cable/VT compartment also contains current transformers, fixed and withdrawable voltage transformers, and the earthing switch, according to individual operating requirements. The cable compartment is constructed for the installation of three current transformers.

Fixed voltage transformers are connected to the primary side with fully insulated copper bars. The withdrawable VT assembly is mounted on rails and the compartment is segregated from the main circuit by means of metallic shutters. Racking of the VT assembly must be carried out with the lower compartment door closed.

The earthing switch for cable and busbar earthing (Depending on the operating requirements ordered by the client) is located in this compartment. Earthing of both the cable and busbar can be achieved by operating the mechanism situated between the circuit breaker and VT Compartment doors.

### 3.1.4 Low Voltage Compartment



Auxiliary equipment such as relays, position indicators, meters and instruments are housed in the low-voltage compartment of each panel. Measuring and indicating equipment is fitted to the door of the low-voltage compartment together with the electrical operation push buttons. An optional Ammeter/Voltmeter and phase selector switch can be mounted in the LV compartment to provide Current/Voltage measurement for the circuit. Alternatively, multi-function measuring meters can also be fitted. The Low Voltage compartment can also include a Local/Remote Switch and test plug for injection of Current and Voltage.

## 3.2 Withdrawable and fixed equipment

### 3.2.1 Circuit Breaker

The circuit breaker used on the **MSG™** switchgear is the VD4 type supplied by ABB. (Other circuit breaker types such as the HD4 and VM1 can also be provided on request). VD4 circuit breakers are provided with vacuum interrupters. This assembly is mounted on a truck with built-in racking mechanism.

Electrical control signals are supplied from the low-voltage compartment via a secondary plug. Mechanical and electrical interlocks prevent unintentional switching.

Refer to separate Operations and Maintenance Manual for the Circuit Breaker.

#### 3.2.1.1 Circuit breaker positions

Removed position



The unit is in the removed position when:

- The compartment door is open
- The unit is moved in-front of the panel ready for insertion, or
- The unit is moved completely out of the panel.

Isolated / test position



The unit is in the isolated/test position, when:

- The unit is in the panel but moved to the front of the compartment,
- The primary contacts are disconnected, the shutters are closed and
- The secondary plug is connected (control over the operation of the unit is now possible )
- The compartment door can be opened.

Service position



The unit is in the service position, when:

- The unit is fully inserted and engaged into the compartment.
- The primary contacts are connected and
- The secondary plug is connected
- The compartment door cannot be opened.



**WARNING:** In emergency situations, the door interlock can be defeated with the use of tools. (See section 4.1.10.2)

### 3.2.1.1 Typical circuit breakers

**630A**

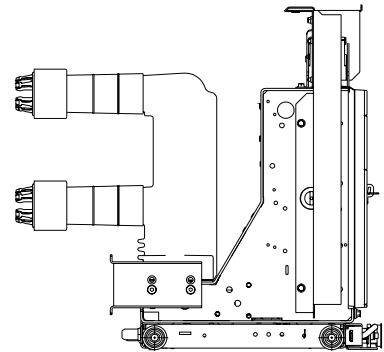
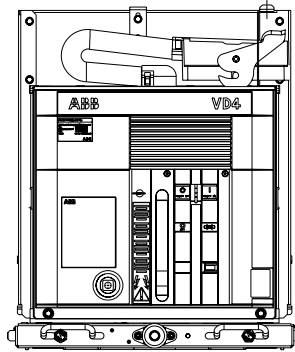

**1250A**

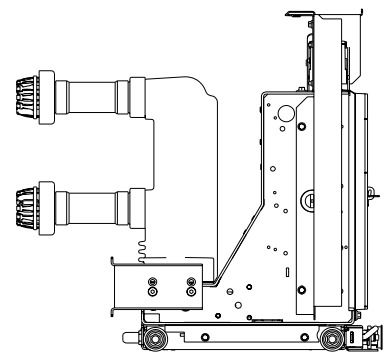
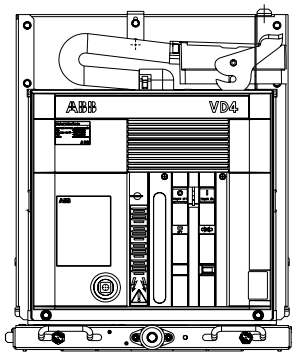

**2000A**

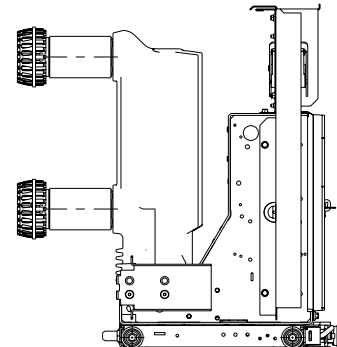
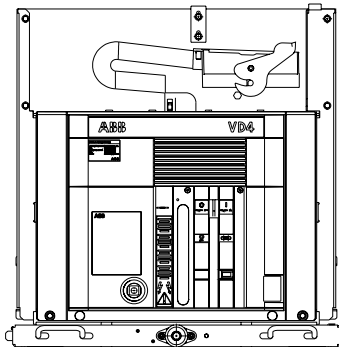

### 3.2.1.2 Circuit breaker controls

The withdrawable circuit breaker forms a complete module consisting of vacuum circuit breaker, isolating contact arm and contact system, the secondary wiring plug together with all the mechanical controls and indication systems required.

All operations and indication can be carried out locally from the front of the breaker (with compartment door closed when in the service position). The breaker front and supporting truck also house the mechanical locking/interlocking facilities with the compartment equipment and door. It also has the operation counter.



- Secondary control wiring Plug
- Key lock OFF position
- Mechanical OFF push-button
- Mechanical ON push-button
- Mechanical switch position indicator
- Mechanical spring charge indicator
- Circuit breaker rating plate
- Mechanical operation counter
- Mechanical rotary spring charging drive
- Door-circuit breaker interlock
- Mechanical racking drive
- Sliding truck racking-interlock handle

**3.2.1.3 Circuit breaker switch position Indication**



Red and green status indication lamps on the Low Voltage Compartment door are used to indicate the OPEN/CLOSE status of the circuit breaker. In case of a power outage, the status of the breaker can also be viewed through the polycarbonate window of the breaker Compartment. Mechanical flags on the circuit breaker front panel will give the status of the circuit breaker including the status of the spring charge.

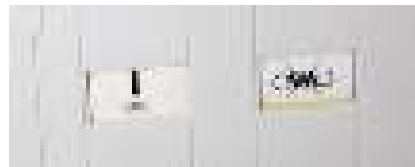

### 3.2.2 Voltage transformers



The installation may include a number of voltage transformers to measure the voltage on the cable and/or busbar side. Voltage transformers can be of two types:

- Cast-resin insulated, Fixed type (standard)
- Cast-resin insulated, fused, Voltage transformer mounted on a withdrawable truck with integral racking mechanism used to measure the voltage of the busbar or cable side depending on configuration (optional)



#### VT Positions

UNIT TYPE	FIXED VT	WITHDRAWABLE VT
Feeder	VT Compartment	VT Compartment
Bustie	N/A	N/A
Riser	Cable Box	Circuit Breaker Compartment
Measurement	Cable Box	Circuit Breaker Compartment

The withdrawable VT is designed for safe operation. On retracting the VT from the service position, the secondary contacts are disconnected. This will eliminate the possibility of reverse feed on the Primary of the transformer.

The VT is also equipped with 2 Secondary plugs; one for the transformer secondary circuit required for voltage measurement and the other for position indication. The plugs are configured so that the operator shall not come in contact with live parts.

### 3.2.3 Current transformers



**MSG** switchgear can be equipped with current transformers for protection, measuring and metering. Current transformers are always fitted in the rear of the cable compartment of Feeder panels or Bustie panels.

### 3.2.4 Voltage Detection System



The voltage indicator is mounted on the low-voltage compartment door. The voltage indicator is connected to a capacitive divider inside each of the Current transformers. When the cable is live the indicator lamps will light up.

### 3.2.5 Earthing switch



Each panel is fitted with a short circuit proof earthing switch fitted either to the cable side and/or the busbar side. The earthing switch connects the points of the cable/busbar with the earthing busbar. A mechanical interlock ensures that the earthing switch is always open when the circuit breaker is in the connected position.

The earthing switch can be closed only with the circuit breaker in the isolated/test position or completely removed.

The earthing switch can be key locked in both the open (optional) and closed (standard) position.

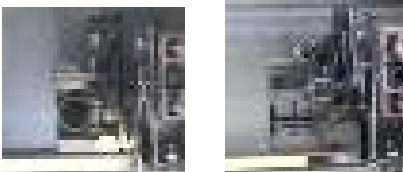

Earth switch position can be viewed either from the position of the drive mechanism or by means of the appropriate indicator on the switch mechanism when viewed through the viewing window located underneath the circuit breaker door.



### 3.3 Enclosure and partitioning



The enclosure and internal partitions of the panels are of 2 mm thick high quality galvanised steel sheets.

The three high voltage compartments (busbar compartment, circuit breaker compartment and cable connection compartment) are equipped with top-mounted and secured pressure relief flaps. These open in the case of overpressure due to an internal arc fault and channel the gases and shock wave into the exhaust gas compartment situated on top of the units. The front of the panel is closed off by pressure resistant doors which open to an angle of 120°. VT/Cable and circuit breaker compartments have separate doors.

The circuit breaker and VT/cable compartment doors are pressure resistant and equipped with inspection windows made of 6mm polycarbonate.

Neighbouring panels are partitioned from one another by the side walls of each panel. The enclosure is completed above by the top-mounted pressure-relief flaps which are made of expanded metal and below by means of floor covering, made of sheet metal.

The pressure-relief flaps are secured with steel screws on one longitudinal side and on the other longitudinal side with plastic screws. In the case of internal overpressure, the plastic screws are the point of rupture.

The gas duct fitted in a form appropriate for the design of the building, will channel any gases together with the shock wave and arc discharge out of the switchgear room.

The internal metallic partitioning provides safe access to the circuit breaker and cable compartments even when the busbars are live. The low voltage compartment for the secondary equipment is completely protected from the high voltage area thanks to its steel-sheet casing. On the end sides, cover plates ensure good appearance and are mechanically and thermally arc fault proof should such an event occur in the end panel. Doors and end cover plates are powder coated with polyester type powder paint. The finishing coat is in the standard RAL 7035 colour (special colours by agreement). Stoving completes the procedure and provides considerable insensitivity to impact and corrosion.

### 3.4 Ventilation of the panels

For units up to 2000A no ventilation is required.

### 3.5 The exhaust gas compartment

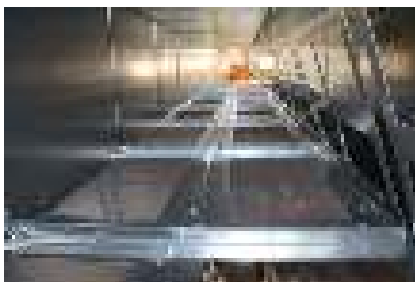

The highly unlikely event of an internal arc in a switchboard generates overpressures in the relative compartment with the emission of hot gases and particles of material.

This release must be suitably controlled in order to protect people and objects in the immediate vicinity from any injury or damage. The exhaust gas compartment of the **MSG™** is suitably sized to handle the pressures and thermal shocks sustained during such events.



**CAUTION:** When switchboard is placed on open cable trenches make sure that any unused trenches are closed so that hot gases are not released from these openings.

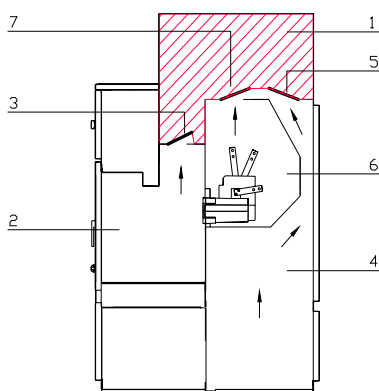

The **MSG™** standard arc-proof version features a Compartment in the top part for collecting and conveying internal arc gases. The Compartment ends must be extended externally to a safe area, by means of a gas duct, so as to safeguard operators working either in front of the switchboard or in the accessible sides and also prevent deposit of gases and overpressures inside the installation room. This configuration complies with IEC 62271 Standard accessibility Class AFLR.

Evacuation of the gases in the switchboard takes place as follows.

- Internal arc in the circuit breaker compartment (2) – the flap (3) opens up and the gas is conveyed into the Compartment (1).
- Internal arc in the busbar compartment (6) – the flap (7) opens up and the gas is conveyed into the Compartment (1).
- Internal arc in the feeder compartment (4) – the flap (5) opens up and the gas is conveyed into the Compartment (1).

The gas flows through the Compartment (1) and comes out of the external outlets through the gas duct.

### 3.6 The gas duct



**NOTE:** All the necessary ducting to route the Internal Arc gases safely out of the substation are outside the scope of supply. Medelec switchgear Ltd. can provide detailed drawings of the duct cross section and substation details.

The duct extensions must be made from metallic sheets of thickness 2mm that has to withstand a minimum pressure of 60 kPa, with a cross-section of at least the same size as the existing duct section and, (only if necessary) with curves suitably supported and of the largest radius possible.

See section 6.6 of this manual for the substation housing details.



**CAUTION:** Pay the outmost attention to the gas outlet area access and protect the outlet (outside) so as to avoid the infiltration of water, dust, animals or other foreign bodies.

In case of special installations, do not hesitate to contact Medelec Switchgear.

### 3.7 Typical Units

#### 3.7.1 Incoming panel

The Incoming panel is a circuit breaker panel intended to provide isolation from the power supply and offering short-circuit protection and switching of the circuit. This is usually provided with voltage and current measurement together with earthing switch on the cable side. The voltage transformer can be either of the fixed type (standard) or of the withdrawable type complete with HV fuses (optional).

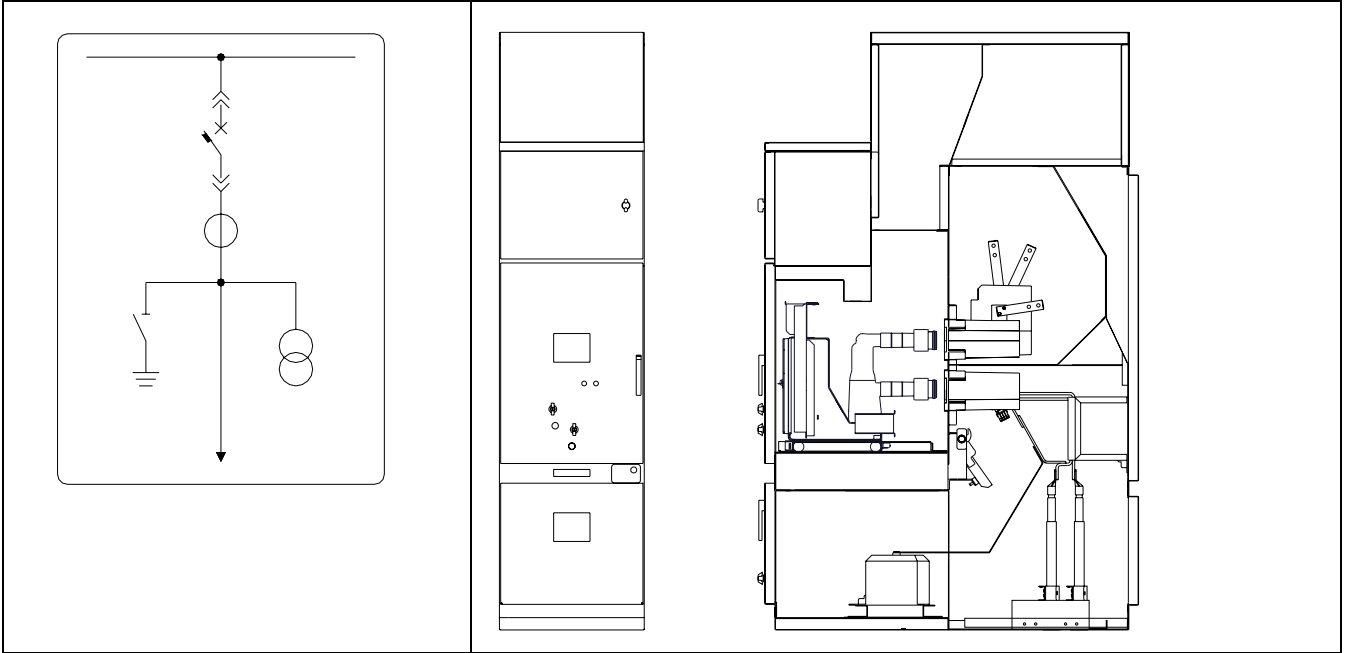

**Incoming panel with fixed VT**

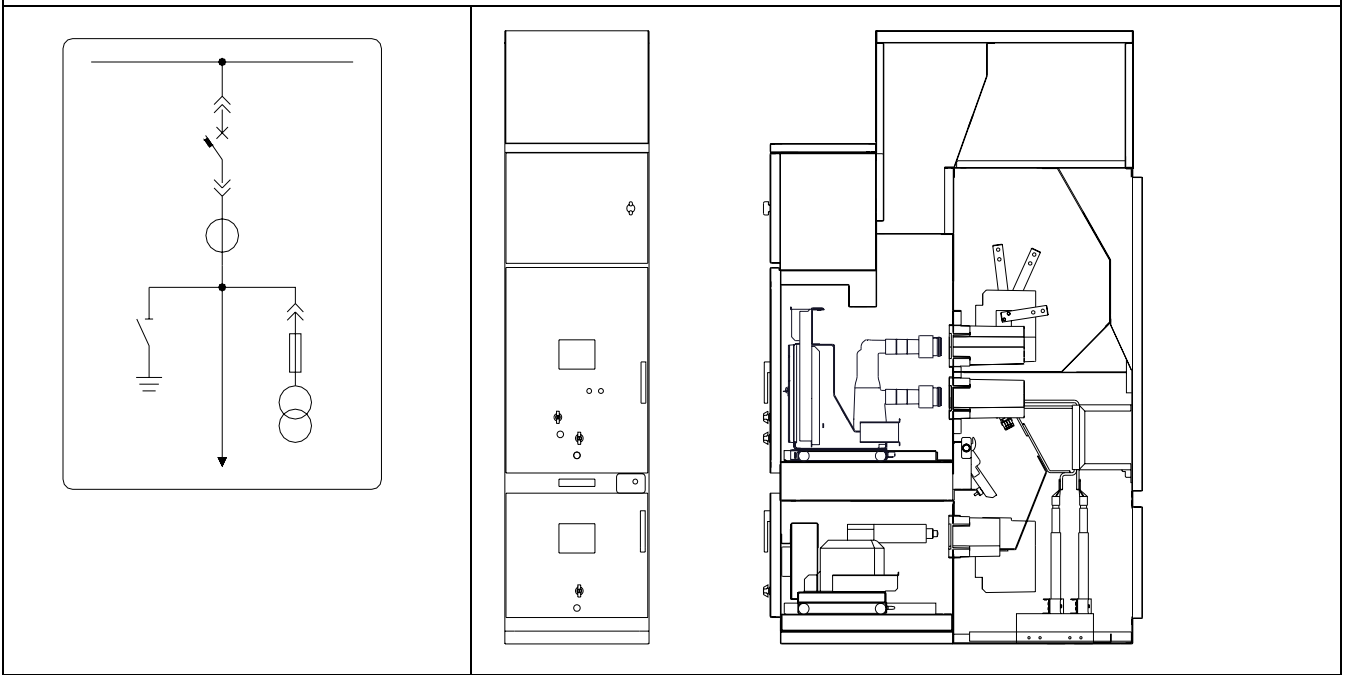

**Incoming panel with withdrawable VT and HV fuses**

### 3.7.2 Outgoing panel

The Outgoing panel is a circuit breaker panel intended to provide isolation from the power supply and offering short-circuit protection and switching of the circuit. This is usually provided with current measurement, and a standard earthing switch on the cable side.

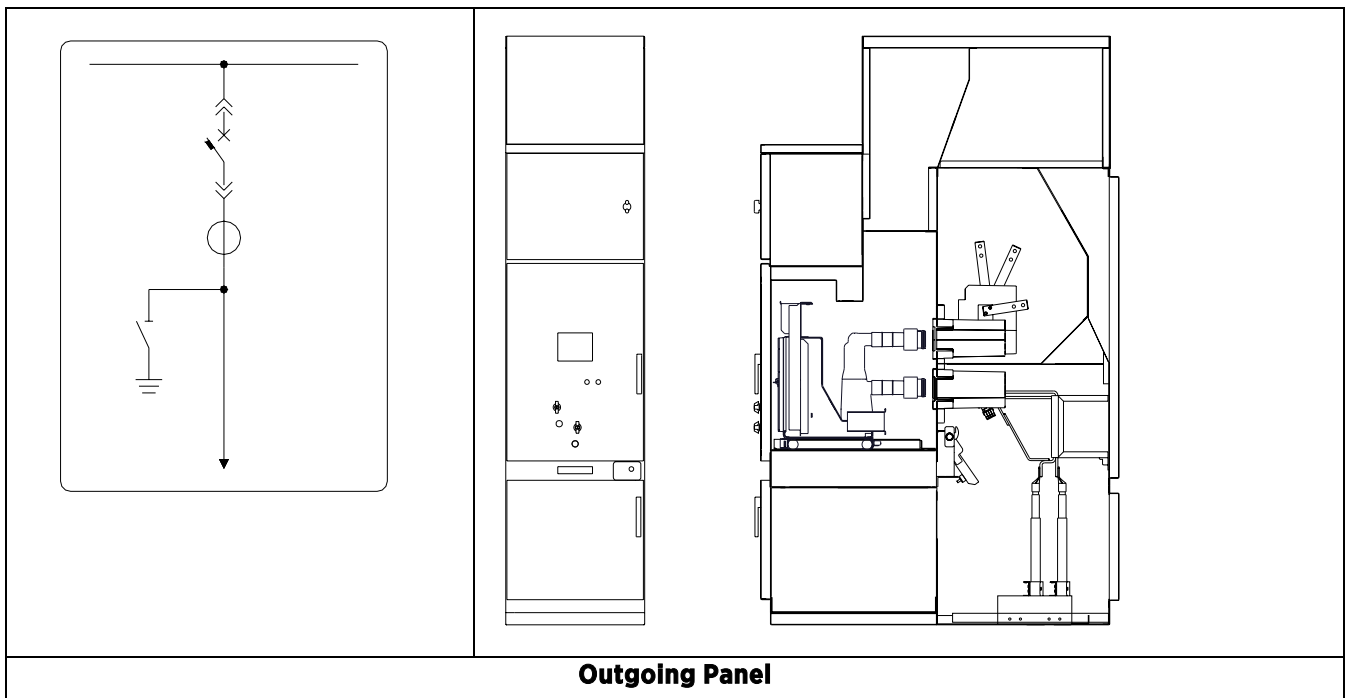

### 3.7.3 Busbar Tie (Bustie)

The Busbar Tie panel and Riser combination allows switching power from one Busbar Section to the other. The Bustie may be equipped with current measurement together with Busbar earthing on one of the Busbar Sides

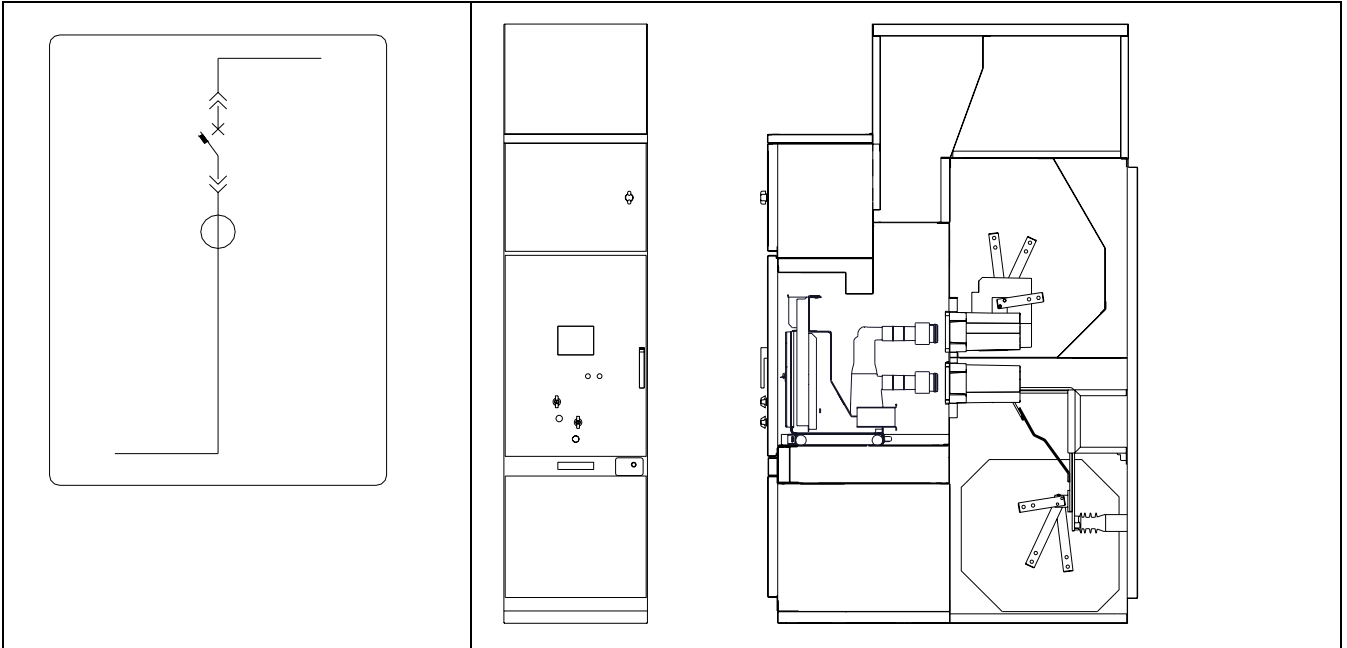

**Bustie Panel with current transformer and without earthing switch**

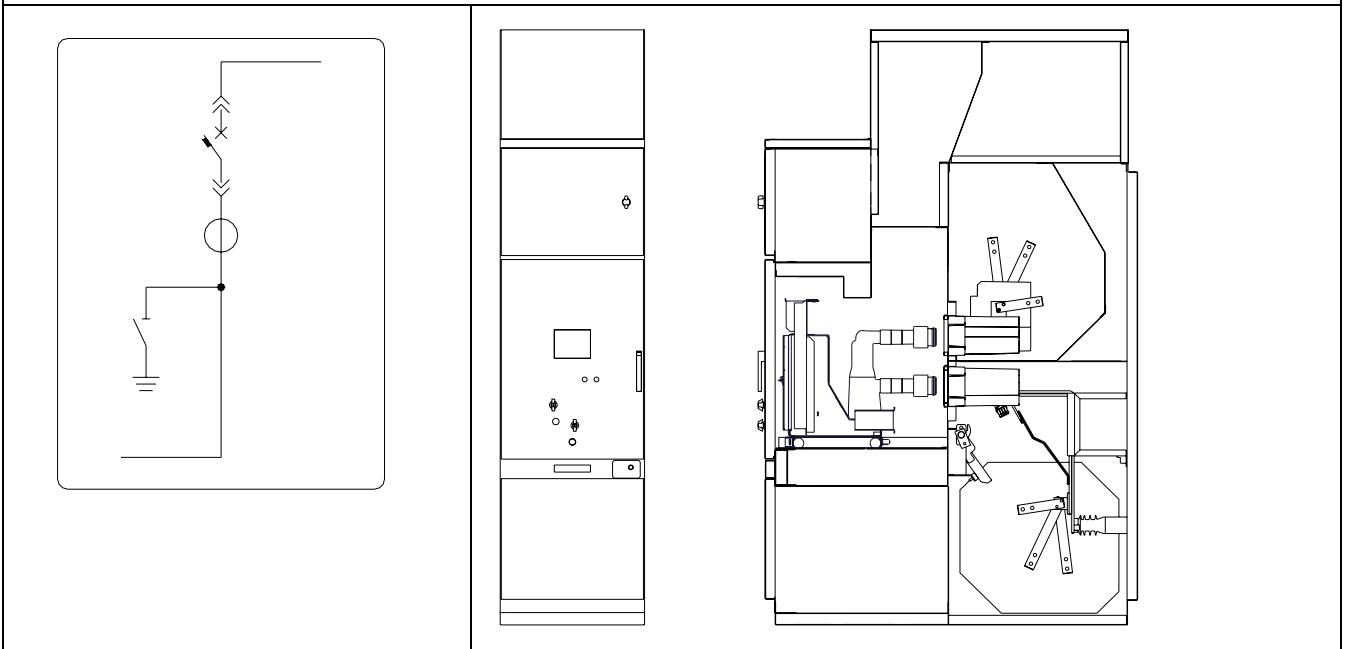

**Bustie panel with current transformer and with Busbar earthing**

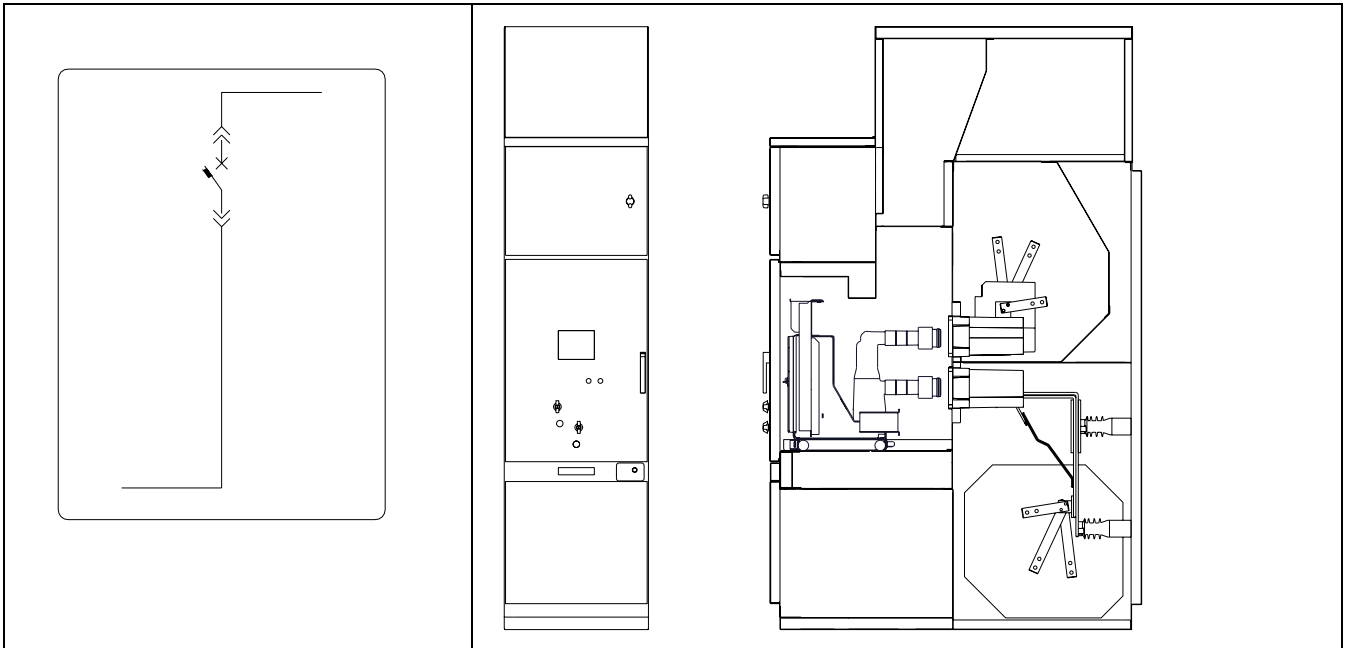

**Bus tie panel without CT and without earthing switch**

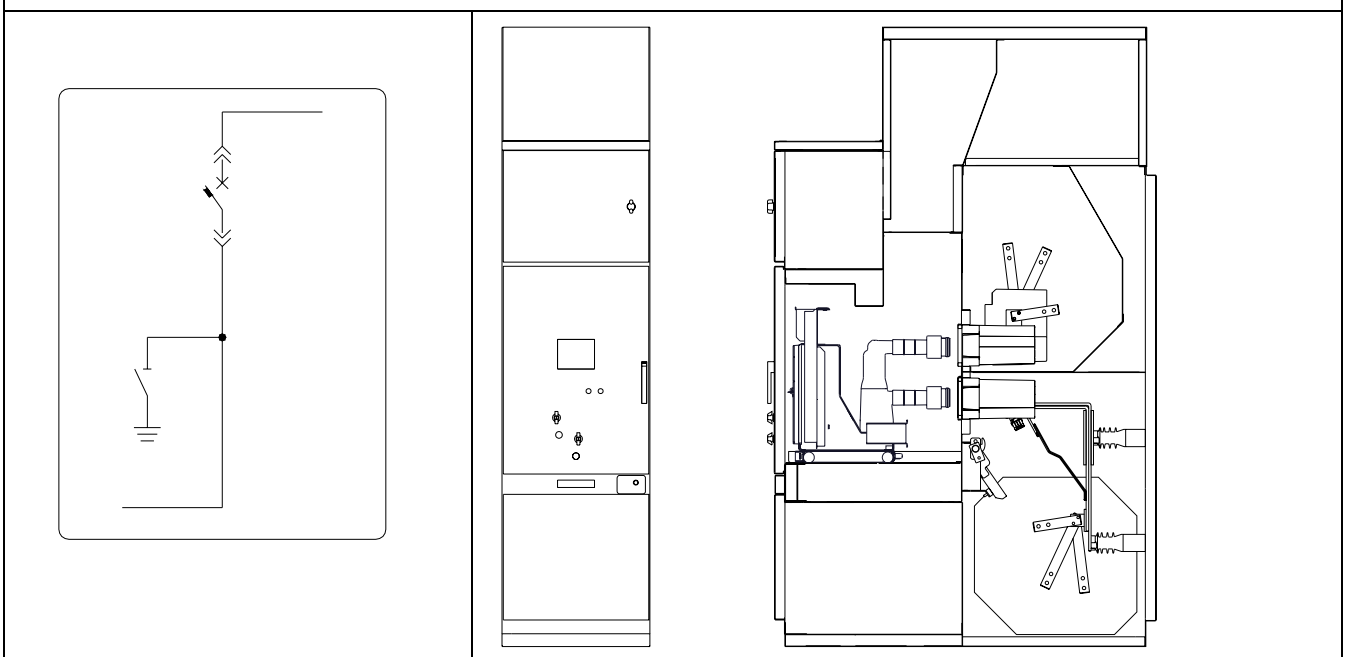

**Bus tie without CT but with Busbar earthing**

### 3.7.4 Busbar riser

The Busbar Riser panel in combination with the Bustie allows the transfer of power from one Busbar Section to the other. It may be equipped with voltage measurement. The voltage transformer can be either of the fixed type (standard) or of the withdrawable type complete with HV fuses (optional).



**Busbar riser with fixed measuring VT**

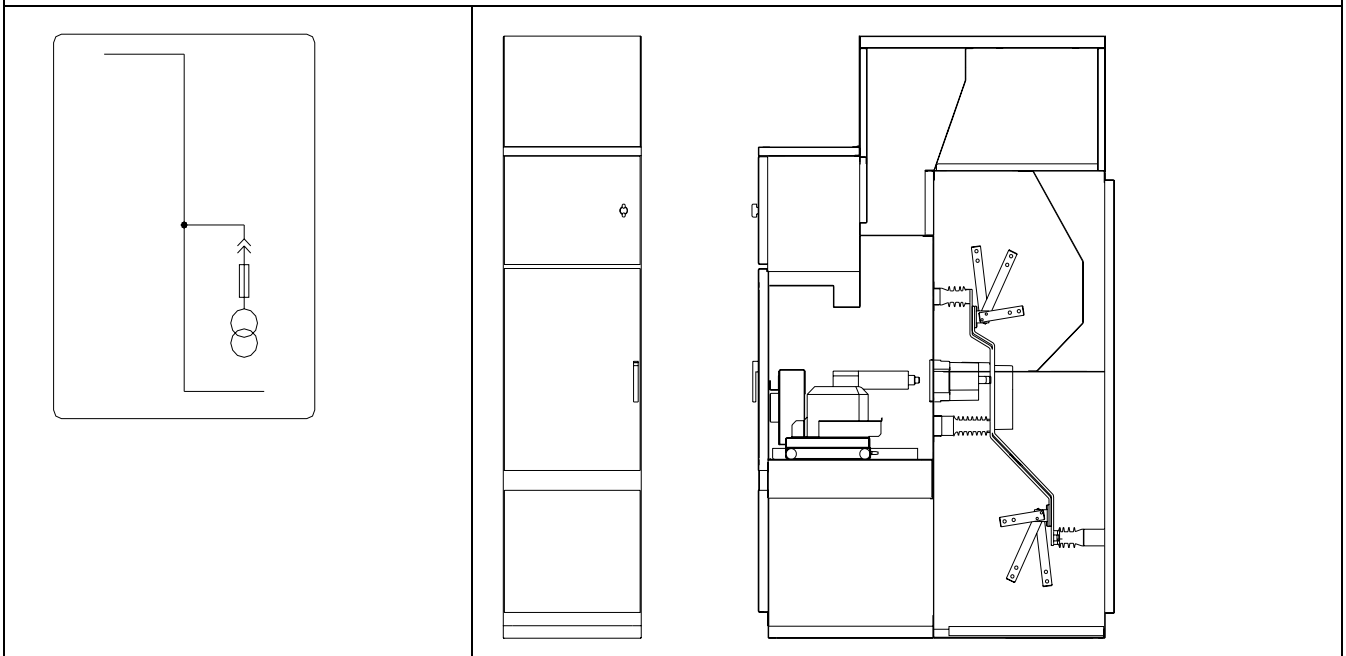

**Busbar Riser with withdrawable measuring VT c/w HV fuses**

### 3.7.5 Measurement panel (Client-specific optional)

A measurement panel allows for voltage measurement together with earthing on one of the Busbar sections. The voltage transformer can be either of the fixed type (standard) or of the withdrawable type complete with HV fuses (optional).



**Measurement panel with Fixed VT and earthing switch.**

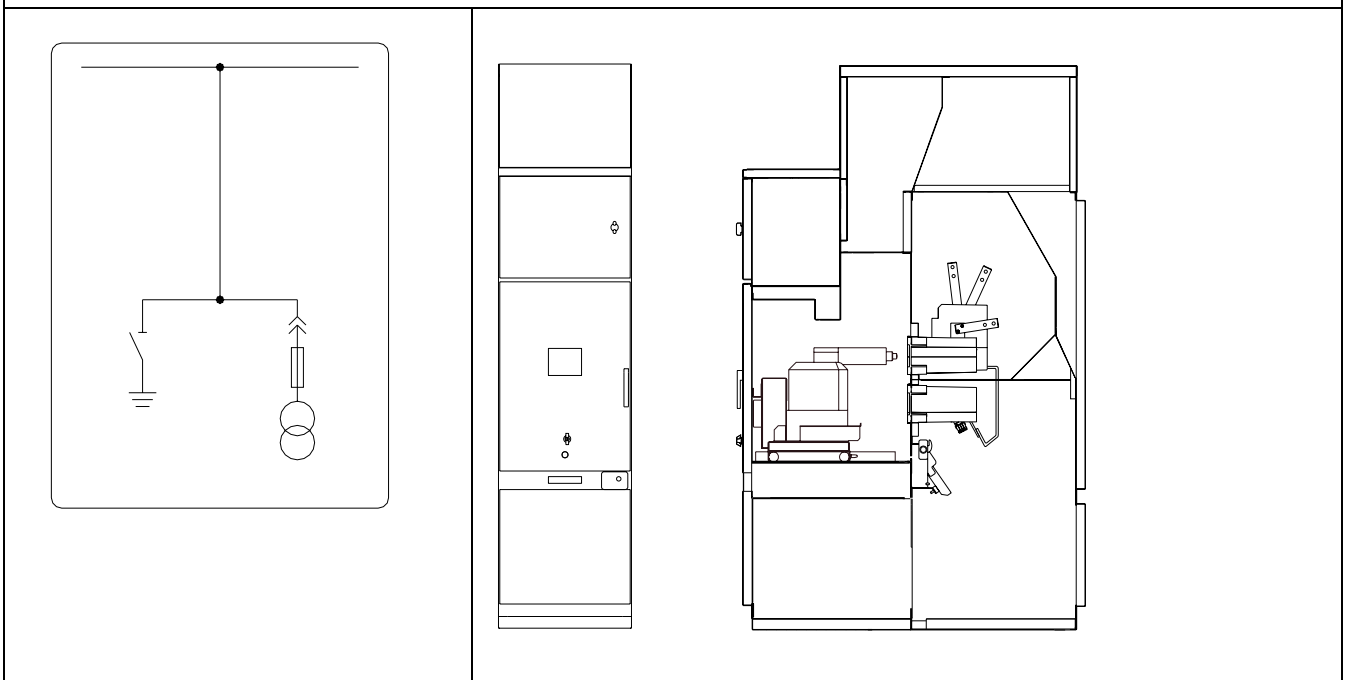

**Measurement panel with withdrawable VT and earthing switch.**

## 4 Interlocks

To prevent hazardous situations and erroneous operation, **MSG™** switchgear is equipped with a series of interlocks to protect both personnel and equipment.



**WARNING:** Interlocks must only be removed by approved operators and only if absolutely necessary for operational reasons. When removing an interlock, the operator must take special and adequate safety measures to prevent situations, which might have fatal consequences.



**Warning:** It is important that where covers are supplied with screws, such as cable compartment covers and busbar covers they must be removed only when the circuit is dead and earthed.

Before removing such covers make sure that the power cable and all busbars are dead and earthing switch is ON for the safety of the personnel.

Only energise the unit once all the removed covers have been re-assembled back on the panel.

### 4.1 Interlock Cross reference table

The following table gives a summary of the interlocks, both mechanical and electrical, supplied as standard with the **MSG™** switchgear.

<b>MSG™ - Type and Interlock description</b>				
Interlock Position	Type	Condition	Direct Action not permitted	Refer to Section
Circuit breaker	Mechanical	Circuit breaker compartment door opened	Circuit breaker insertion	4.1.1
		Circuit breaker closed in isolated position	Circuit breaker insertion	4.1.2
		Circuit breaker closed in service position	Circuit breaker extraction	4.1.2
		Circuit breaker in intermediate position	Circuit breaker closing	4.1.3
		Key locked in circuit breaker open position	Circuit breaker closing	4.1.4
		Circuit breaker locking handles not fully extended.	Circuit breaker insertion	4.1.5

<b>MSG<sup>™</sup> - Type and Interlock description</b>				
<b>Interlock Position</b>	<b>Type</b>	<b>Condition</b>	<b>Direct Action not permitted</b>	<b>Refer to Section</b>
Switchgear	Mechanical	Socket board not plugged	Turning of socket board lever	4.1.6
		Socket board plugged, lever not turned	Circuit breaker insertion	4.1.6
		Socket board plugged, lever in horizontal position	Removal of socket board plug	4.1.6
		Circuit breaker in intermediate position	Circuit breaker compartment door opening.	4.1.8
		Circuit breaker in fully inserted position	Circuit breaker compartment door opening.	4.1.8
		Shutter of the earthing-switch crank lever hole opened	Circuit breaker insertion	4.1.9
		Shutter of the earthing-switch crank lever hole closed	Earthing-switch operation	4.1.9
		Circuit breaker in fully inserted position	Opening of the earthing switch Perspex shutter	4.1.9
		Key locked for earth switch in open position (Optional)	Opening of the earthing switch Perspex shutter	4.1.9
		Key locked for earth switch in closed position	Earthing switch handle insertion.	4.1.9
		Earthing-switch closed	Closing of the earthing switch Perspex shutter	4.1.9
		Earthing-switch closed	Circuit breaker insertion	4.1.9
		Circuit breaker rack in-shutter key locked	Insertion of racking-in handle	4.1.10
	Electrical	Electromechanical lock (BED) de-energised	Earthing-switch operation	4.1.9
		Door solenoid de-energised	Opening of racking-in shutter	4.1.10
Withdrawable VT compartment	Mechanical	VT compartment door open	VT Insertion	4.1.1
		VT in intermediate position	VT compartment door opening	4.1.8
		VT inserted	VT compartment door opening	4.1.8



#### 4.1.1 Withdrawable equipment - racking with door open interlock

This interlock is located on the front of the withdrawable truck and interlocks with the withdrawable part racking drive mechanism. With the door open, this interlock prevents racking operations of the withdrawable part.

#### 4.1.2 Circuit breaker - racking interlock



This interlock is located inside the circuit breaker truck and interlocks the breaker switch position with the withdrawable part racking mechanism. With the circuit breaker ON, this interlock prevents racking operations of the withdrawable part.



#### 4.1.3 Circuit breaker - CLOSE interlock



This interlock is located inside the circuit breaker truck and interlocks the breaker switch position with the withdrawable part racking mechanism. With the circuit breaker in the intermediate position, this interlock prevents switching ON of the circuit breaker.



#### 4.1.4 Circuit breaker - CLOSE lock



The circuit breaker is equipped with a key lock to lock the breaker in the OFF position.

To lock the breaker in this position, press the OFF button on the circuit breaker whilst turning the key lock on the circuit breaker front panel shown in the adjacent photo.



#### 4.1.5 Withdrawable equipment - latching handles



The handles on the withdrawable equipment truck are interlocked with the racking mechanism of the withdrawable equipment. If the equipment is not properly latched to the panel guides, and the handles are not fully extended, racking is prevented. On the other hand, if the withdrawable equipment is not in the fully isolated/test position, unlatching of the handles is not possible.



### 4.1.6 Socket board interlock



The socket board interlock is a handle located next to the secondary wiring plug of the circuit breaker. This is interlocked with the linkages leading to the circuit breaker racking mechanism and prevents insertion of the circuit breaker if the secondary plug is removed.

The handle can only be rotated horizontally with the secondary plug inserted. Rotation of this handle would then allow racking of the circuit breaker from isolated/test position to the service position.



This interlock, linked with the circuit breaker-racking with open door interlock, also prevents removal of the secondary plug when the circuit breaker is in the intermediate and service positions.



### 4.1.7 Circuit breaker secondary plug connector coding

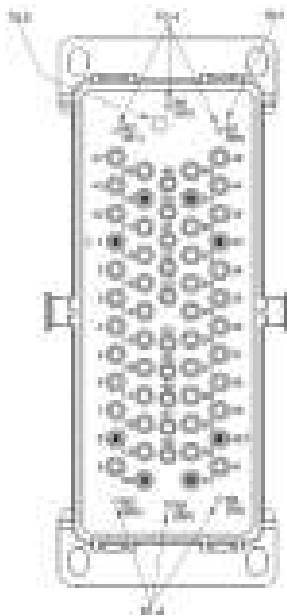

The circuit breaker secondary plugs are coded to prevent racking a breaker into a compartment designed for a different current rating.

The secondary control wiring plug/socket coding allows the circuit breaker to be assigned a particular rating. This ensures, for example, that withdrawable parts with different rated currents or different control wiring circuits can only be used in the panels they are intended for. Coding pins are fitted in the secondary wiring plug of the breaker and corresponding holes are left in the panel secondary socket.



1250A  
Panel

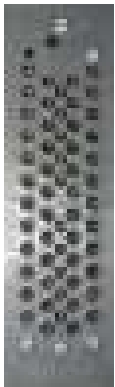

630A  
Panel

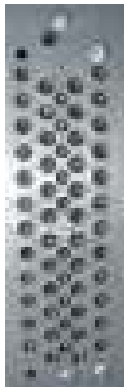

#### 4.1.7.1 Panel plug coding

Circuit Breaker socket pin coding					
	(B1)	(B2)	(B3)	(B4)	(B5)
630A	O			O	
1250A	O				
2000A					O

Panel hole pin coding					
	B1	B2	B3	B4	B5
630A		O	O		
1250A		O			
2000A					O

#### 4.1.8 Withdrawable equipment - door interlock

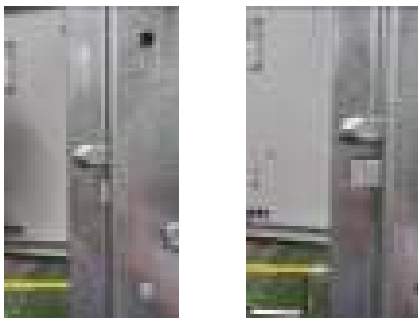

This interlock is located on the right side of the withdrawable equipment compartment.

This interlock is directly coupled to the compartment shutter. It prevents the compartment door opening if the withdrawable equipment is either in the intermediate or service position. Compartment door can only be opened if the equipment is in the isolated/test position.

#### 4.1.9 Earthing switch interlocks

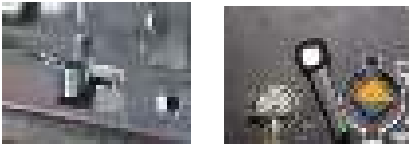

CB moved from isolated/test position to service position - earthing switch OFF and shutter closed



CB in isolated/test position - earthing switch OFF and shutter open

The earthing switch interlocks are located on the earthing switch fascia and mechanism.

With the earthing switch in the OFF position and the front shutter closed, circuit breaker racking from the isolated/test position to the service position is possible.

If the earthing switch is in the ON position, closing of the front shutter is not possible.



If the front shutter is not closed, the circuit breaker racking is not possible.

The front shutter can only be opened with the circuit breaker in the isolate/test position.

The earthing switch can only be operated when:

1. The unit is in the isolated/test position or completely removed.
2. The earthing switch electromechanical interlock is energised.

The earthing switch can be key-locked in the closed position. Optionally another keylock may be requested to lock the earthing switch in the open position.



When used on the Bustie and measurement panels, the busbar earthing switch (optional) can only be closed when all the withdrawable parts in the relative busbar section are either removed or in the isolated/test position. Only in this configuration can the earthing switch electromechanical interlock BED solenoid on the bustie or measurement panel be de-activated (i.e energised).

When used on incoming feeder units, this electromechanical interlock is activated when the remote feeder is switched ON. This will prevent operation of the earthing switch (See section 7.12).

De-energising the remote feeder supply will de-activate (energise) the interlock which would allow operation of the earthing switch.

### 4.1.10 Door Interlocks

The circuit breaker compartment door contains a number of interlocks or padlocks which prevent unsafe operations.



Access to the circuit breaker racking hole can be restricted with a key lock. This prevents opening of the racking mechanism shutter thus preventing circuit breaker racking.

For substations with busbar earthing, when the busbar earthing switch is closed, the racking access shutter to the breaker compartments in the earthed busbar section is blocked. This is achieved by a solenoid located at the back of the compartment door. With this interlock activated (solenoid de-energised) the shutter cannot be opened and the circuit breakers cannot be racked in from the isolated/test position to the service position.



This electro-mechanical lock is also activated (de-energised) when DC supply and panel protection is switched off.

The racking mechanism shutter also contains a micro switch which is connected in series with the circuit breaker electrical CLOSE circuit.



**CAUTION:** Ensure that the shutter on the racking drive access hole is in the completely closed position. If the shutter is open, this indicates that the racking handle is in the inserted position thus preventing circuit breaker electrical closing.



The mechanical CLOSE and OPEN access guide holes on the circuit breaker compartment door can also be padlocked to prevent mechanical operation of the circuit breaker.



#### 4.1.10.1 Door rack-in shutter Interlock defeat mechanism



**WARNING:** Only skilled personnel with suitable knowledge of the circuit breaker and installation must carry out this operation.



**WARNING:** Operation must only be carried out in case of emergency since personnel safety cannot be guaranteed.

In the case when the circuit breaker has to be moved from the service position to the isolated/test position or vice versa, with the solenoid interlocking the racking shutter activated (de-energised), the following procedure has to be followed :

1. Remove the screw located besides the access hole.
2. Insert the long end of the tool used to remove the screw and lightly push the solenoid whilst rotating the shutter until the latter hits the tool.
3. Slowly retract the tool and continue rotating the shutter until the racking drive hole is fully exposed.



**NOTE:** The interlock will reset itself when the shutter is released.

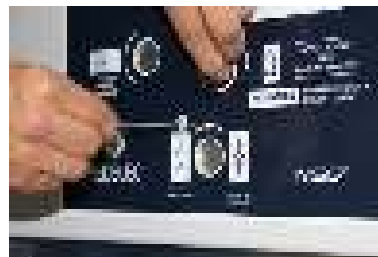

#### 4.1.10.2 Door Interlock defeat mechanism



**WARNING:** Only skilled personnel with suitable knowledge of the circuit breaker and installation must carry out this operation.



**WARNING:** Operation must only be carried out in case of emergency since personnel safety cannot be guaranteed.

In the case when the circuit breaker or withdrawable VT compartment door needs to be opened with the withdrawable part still in the service position, the following procedure has to be followed :

1. Remove the screw located just below the withdrawable part compartment door handle.
2. Insert the long end of the tool used to remove the screw until it passes through the side-frame hole and reaches the interlock.
3. Push the spring loaded interlock and lift the handle of the compartment door.
4. Open the door.



**NOTE:** The interlock will reset itself when the door is opened and will block the door if the latter is closed.



## 5 Packing Transport and Storage

### 5.1 Condition on delivery

At the time of dispatch, the **MSG™** panels are factory-assembled, the withdrawable parts are in the isolated/test position and the doors are closed.

The factory-assembled panels are checked at the factory for completeness in terms of the order and simultaneously subjected to routine testing (normally without AC voltage testing of the busbars) according to IEC publication 62271-200, and are therefore tested for correct structure and function.

The busbars are not assembled. The busbar material, fasteners and accessories are packed separately with the loose gear.

### 5.2 Packing



For reasons of containerised shipping and ease of installation, the units are packed separately inside crates with up to three panels per crate. The exhaust gas Compartment is sent as loose gear with each substation.

No special devices, other than those provided, are required, as assembly is carried out by aligning all the relevant sections.

The switchboards are usually shipped complete with circuit breakers, voltage transformers fitted into the relevant compartments, except when otherwise agreed. The circuit breaker and VT withdrawable truck are packed inside the respective panel and positioned in the isolated/test position.

Each switchboard section is packed in preparation for containerised shipping.

Each group is protected by an aluminium sheet which is heat sealed. The bags are vacuumed and desiccant bags placed inside each bag.

Each panel group is placed on a wooden pallet and a wooden crate surrounds the group. This crate serves to protect the panels during transportation and also to provide lashing points.

### 5.3 Transport

Follow the symbols and instructions shown on the packaging carefully.

Transport the panels upright. Take the high centre of gravity into account. Only carry out loading operations when it has been ensured that all precautionary measures to protect personnel and materials have been taken.

The wooden crate must be fixed to the vehicle by means of ropes so as to avoid any violent impact or turning over in case of sharp turns or sudden stops. Moreover, the vehicle must be fitted with a canvas covering the whole load. The capacity load of the lifting equipment must guarantee proper weight distribution.

If the apparatus is unloaded in the warehouse or in the installation room, the access must be at least 3m high x 2.5 m wide with an area at the same level. Small differences in level can be compensated with temporary structures using wooden boards.

Unloading must be carried out with the utmost care using suitable lifting equipment for the weight of each unit group, especially in presence of energised overhead lines.

### 5.4 Control on receipt



On receipt, immediately check the packing and apparatus conditions.

If the panels are going to be used immediately, open the packing and check that no damage occurred during transport and make sure that the rating plate data correspond to those listed in the Substation general arrangement.

Should any damage or imperfection in the supply be noticed, report immediately to Medelec Switchgear Ltd. (directly or through the agent or the supplier) and to the carrier who delivered the goods.

Notification of any possible irregularity, even after receipt, must indicate the switchboard construction year and the relevant serial number which are shown on the switchboard rating plate.

The switchboards are only supplied complete with the accessories specified in the offer sent by Medelec Switchgear Ltd.

The documents enclosed in the packing are:

- Contract related documents, including the General Arrangement, Schematic and wiring diagrams.
- Typical drawings to assist during assembly of the switchboard.
- This instruction manual.

In the case that the units will not be used immediately on receipt, follow the procedure listed in 5.5 below.

## 5.5 Intermediate storage

Optimum intermediate storage, where this is necessary, without any negative consequences depends on compliance with a number of minimum conditions for the panels and assembly materials.

Store the panels upright and do not stack panels. Store the units protected from the weather in a dry, dust-free, non-corrosive place and safe from any damage.

Check the packing for damage and regularly check for any condensation until installation is started. If any damage to the packing is noticed, carefully open the packing and inspect the units for signs of transportation damage or water ingress.

In case of damage observe procedure as detailed in 5.4 above. If no damage is noticed, replace the drying agents and re-seal the aluminium bags.

When the maximum storage period is too long the protective function of the packing can no longer be guaranteed and suitable action must be taken if intermediate storage is to continue. The packaging contains dehydrating bags that must be replaced every six months.

In particular instances of very long storage, it is advisable to store the units in an indoor space. It is also advisable to connect the anti-condensation heater whenever this is supplied on the switchgear.

## 5.6 Handling

### 5.6.1 Handling the Switchgear

Switchgear units are packed on wooden pallets surrounded by a wooden crate. The panel groups must be handled by means of a crane or fork lift truck.

When using a crane, use a circular sling which must be inserted according to the lifting symbols marked on the crate.

Weight and lifting opening angle must be taken into account when choosing the circular slings.

## 5.6.2 Unpacking and switchboard handling



Follow the procedure below to unpack and handle the separate switchboard units :

- Remove the protective wooden cage.
- Remove the protective aluminium sheet.
- Remove the screws fixing the switchboard to the pallet and any other means used to keep the units stable during transportation.
- Only use the lifting devices supplied.
- After unpacking, lift the panel by means of a crane (use the lifting devices and chain slings fitted with safety latches).
- Hook the chain hooks to the lifting device holes.
- Insert the bolt heads of the lifting devices into the keyholes on the sides of the unit. Use those situated on the extreme ends of the unit.
- Push the lifting bolts against the switchboard and allow them to slide upwards until the screws touch the slot upper part.
- Lift the unit carefully. If required, adjusting the length of the chain to allow for shifts in the centre of gravity of each panel.

Once removed from the packing, the units can be either handled by crane or else shifted to the installation location by means of a forklift truck or pallet loader or else by using rollers. In the latter cases, only use the rollers or forklift trucks on level floor and avoid any tilt. When using rollers, always put a sturdy metal sheet between the rollers and the unit base.



### 5.6.3 Handling the removable parts



The removable Components can be handled by means of cranes, fork lift trucks or using the trolley provided with the switchgear.

For each component follow the instructions below.



**CAUTION:** Before handling the apparatus, make sure that the operating mechanism springs are discharged and that the apparatus is in the open position.



**NOTE:** While handling, do not put any stress on the insulating parts and on the apparatus terminals.

When handling by crane, hook the lifting device to the relevant supports.



When handling by means of a forklift truck, do not insert the truck forks straight underneath the removable components but put the components on a sturdy support.

For handling and inserting the apparatus into the switchboard, use the trolley supplied by Medelec.



In order to shift the circuit breaker to the relevant trolley, follow the instructions below:

- Hook the lifting devices to the circuit breaker supports and align it above the trolley.
- Press the handles towards the circuit breaker centre to make the horizontal check pins go in.
- Put the circuit breaker on the trolley.
- Push the circuit breaker towards the back of the trolley until the handles are released outwards and the horizontal locking pins go into the slots, locking the circuit breaker.



The same procedure applies to the withdrawable VT truck.



**NOTE:** When lowering the withdrawable part ensure that the truck interlock does not foul the operation.



**NOTE:** The lifting devices provided on the circuit breaker must be removed before the unit is put in operation.

## 6 Installation

### 6.1 Installation - General Information

Correct installation is of paramount importance. The instructions given in this manual must be thoroughly studied and followed.

Installation must be carried out either by Medelec personnel or by suitably qualified and skilled customer personnel trained by Medelec with in-depth knowledge of the apparatus.

It is advisable to wear gloves for handling the components.

Before removing the circuit breaker panel cover make sure that the circuit breaker is open and the closing springs discharged.

Do not walk over the switchboard when it is energized.

The switchboard room must be dry, clean and complete with all the necessary fixtures and fittings (cable duct, gas outlets etc.).

The following limit values, among others, apply:

Ambient temperature:

Maximum +40 °C

Maximum 24 h average +35 °C

Minimum -5 °C

The maximum site altitude is 1000 m above sea level.

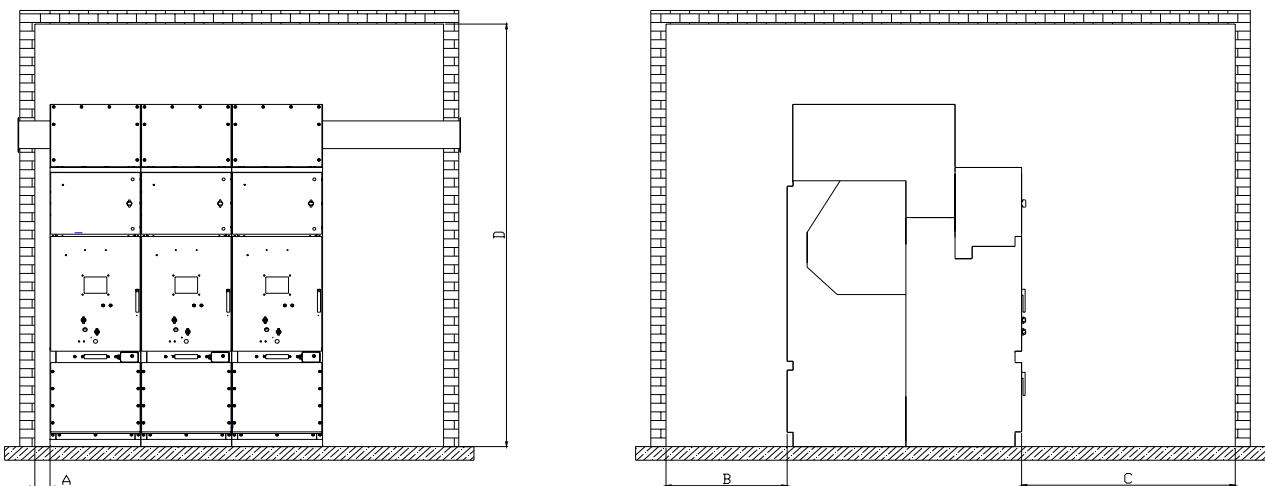

	Details	Dimension (mm)
A		100
B	Free standing unit	800
	Wall mounted unit	100
C		1500
D	With gas duct	2710

## 6.2 Foundation and switchgear erection

After the order acknowledgement, Medelec Switchgear will supply the customer with the switchboard foundation and fixing drawings to prepare the installation room. The floor or the foundation must be strong enough to bear the weight of the switchboard (plus all the circuit breakers) without any deformation.

### 6.2.1 Tightening torque table

The table below gives the torque values for fixing and coupling switchboards and busbars.



**CAUTION:** Do not grease the screws or nuts.

Screw Type: 8.8G	Tightening Torque (Nm)
M6	9.0
M8	22
M10	45
M12	75
M16	185
M18	260
M20	250
Tolerance: -0% to +20%	

### 6.2.2 Foundation details

Correct operation of the Switchgear is dependent on it being level. It is essential, therefore, that care is taken at all stages of erection, in particular the alignment and levelling of the first unit, which will be the datum for all other units. Failure to erect the first unit correctly will result in misalignment throughout the switchboard. Foundation fixings may be of the unistrut foundation channel type (See Section 6.2.3) or of the foundation bolt type, expanding type (See Section 6.2.4)

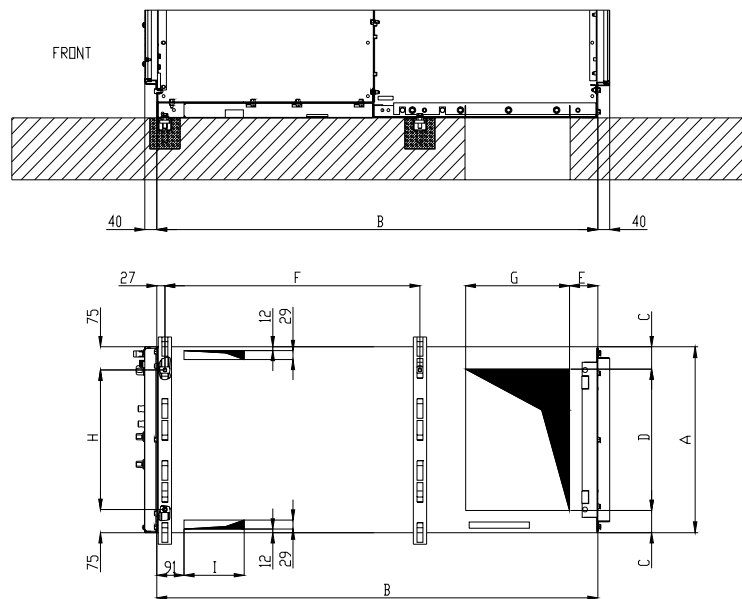
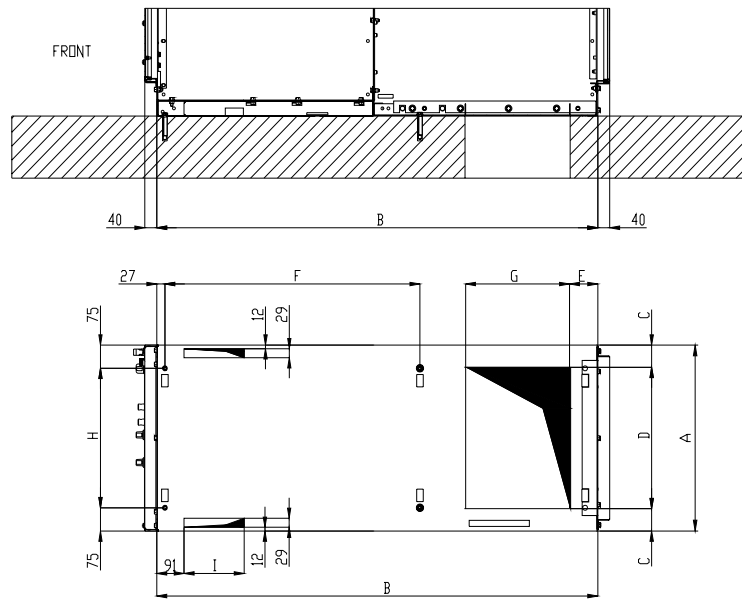

Unit Type	Unit Rating	Dimension (mm)								
		A	B	C	D	E	F	G	H	I
Feeder, Bustie, Riser, Measurement Panel.	630..1250A	600	1470	72	455	95	850	345	450	200
Feeder, Bustie, Riser.	2000A	750	1470	72	605	95	850	345	600	200

### 6.2.3 Fixing with unistruts foundation Channels



The unistruts foundation channels, which can be supplied on request, must be installed in the floor concrete slab before finishing the floor. Prepare the floor and foundations taking into consideration the location of the cable trench.

Rest the unistruts in the appropriate cavities in the floor and line them up so that they are parallel and are spaced from each other as shown in the foundation drawing. Level the channels both longitudinally and transversally using the straps and cross braces supplied. Fix the unistruts in this position with concrete. Complete the flooring so that the surface of the unistruts extend out at least 0.5 mm from the finished floor surface.

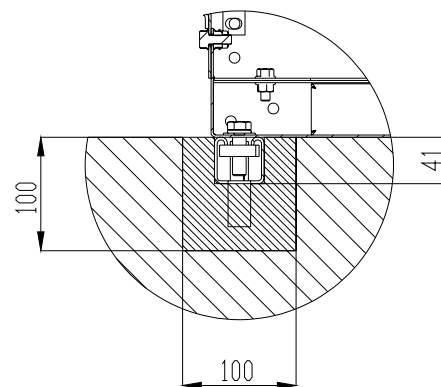
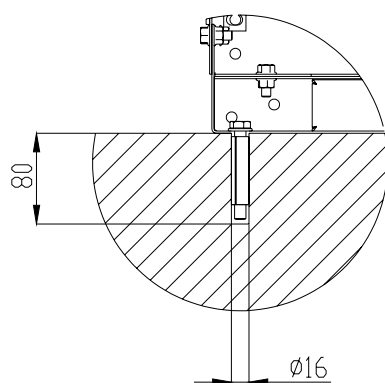

### 6.2.4 Fixing with anchoring bolts (Expanding type bolts)

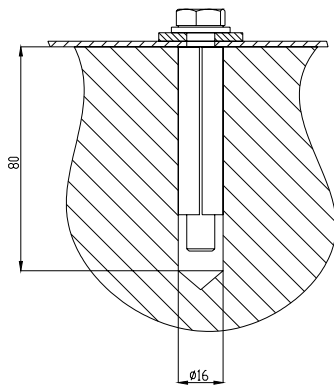

The round holes in the base of the housing can be used as a template to drill the floor for accepting M12 x 75mm long expanding bolts. After drilling, clean the installation area. On the floor, visibly trace the perimeter of all the cubicles making up the switchboard, taking the minimum wall and obstacle clearances, and location of main cable trenches into account. If necessary level the floor both longitudinally and transversally.

Proceed with the installation of the panels as described in section 6.2.5 below. Instead of the anchor nuts, insert the expansion anchoring bolts in the holes and fix the panel to the floor with M12 bolts. Apply a standard torque of 70Nm.

### 6.2.5 Position and fixing the units on the foundation



**CAUTION:** It is advisable to leave the circuit breakers, and voltage transformer trucks (where possible) inside the panel until the panels are fixed to the floor:



**NOTE:** To guarantee correct alignment of the different sections it is advisable to draw a line parallel to the switchboard front and keep a constant distance from this line while positioning and fixing the units.

The various units must be fixed to the channels ideally starting either from the central section or from the highest point on the unistrut channels, and then proceeding to the side cubicles. This starting point then becomes the datum for all units. Although it is ideal to use this point for erection of the first unit, installation can also be started from the extreme units if the layout does not permit otherwise.

With reference to the general arrangement drawing of the switchboard, check the unit serial numbers for correct sequence of erection.

To position the units lift the unit with the appropriate lifting attachments and place it on the foundation layout.

Locate the foundation holes and insert the anchoring nuts (in the case when unistrut foundations have been laid) through the rectangular openings and fix the unit with the supplied screws through the appropriate round holes adjacent to the rectangular cut-outs. Fit the fixing bolts and associated washers through the holes in the base of the housing into the spring loaded nuts within the channels. **DO NOT TIGHTEN** for the time being. Using 2 plumb lines level the housing front to back and across the width. Levelling is carried out using the shim plates provided. These shims shall be located adjacent to and on the outside of the foundation bolts such that they will also support the adjacent housing when erected.

Position the adjacent unit on the foundation frame and ensure all the panel-to-panel fixings are aligned. Fit and tighten some of the panel-to-panel fixings to secure panel alignment. Check the alignment of the instrument panels for squareness and spacing between panels. Fix the panel to the foundations.

Repeat the above for the remaining housings remembering to check the unit serial numbers. Finally, tighten all foundation bolts and all the accessible panel-to-panel fixings.

At this stage completely remove the circuit breakers, and voltage transformer trucks and any covers to access the remaining panel-to-panel fixing holes. Fit the necessary screws following the diagram below and tighten. The screw and nut tightening torque values for fixing and coupling switchboards and busbar are given in section 6.2.1.



**WARNING:** No screws must be fitted in the vertical middle row next to the shutter drive levers. These are omitted to provide clearance for the shutter drive levers. If this step is omitted and standard screws are used, the head/nut of the screw will foul with the shutter drive lever. This will prevent the shutter from closing properly and presents a safety hazard for the operators.

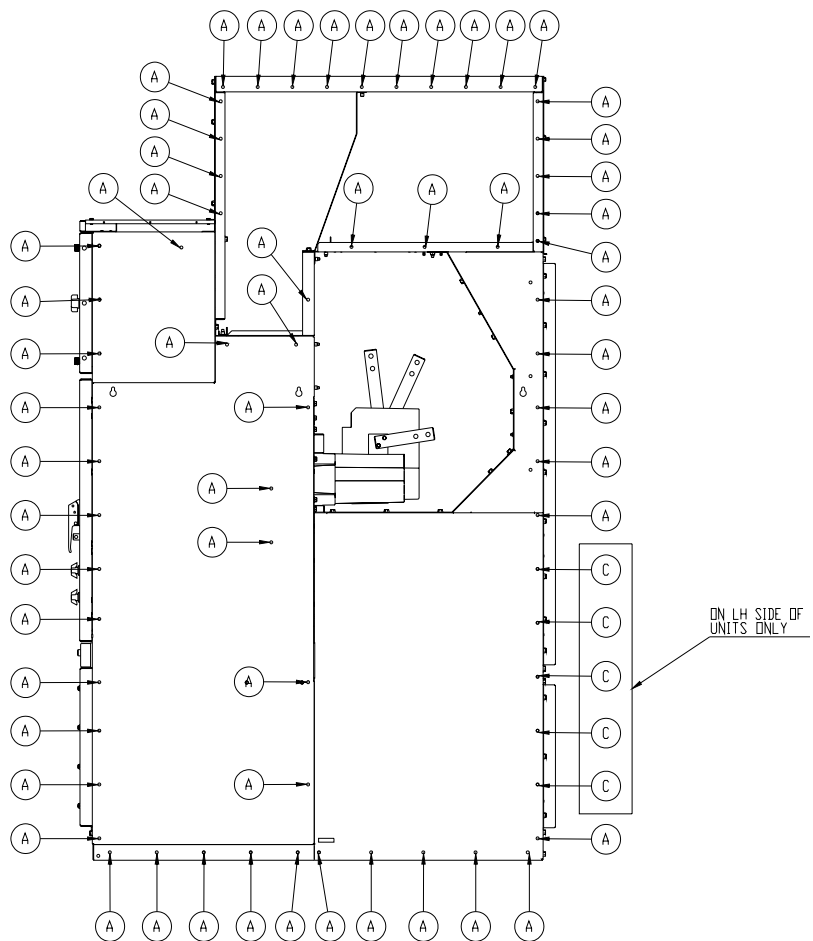
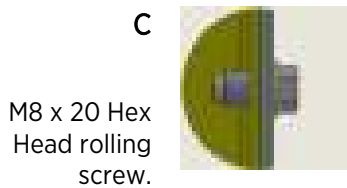
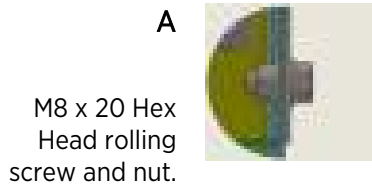

### 6.3 Main Busbar Assembly



**NOTE:** The connections are made either of bare copper or of silver-plated copper. Make sure that the connection contact surfaces are perfectly flat, without any burrs, oxidation traces or deformations.

The inter unit busbars are coupled by means of standard tools. All the necessary coupling bus bars are supplied with the equipment.

Access to the busbar compartment for making the busbar joints is via removable covers at the back of the unit.

In the case of wall mounted panels, access to the busbar Compartment is via the top of the unit prior to fitting the gas Compartment. This is achieved by removing the filter mesh panels.

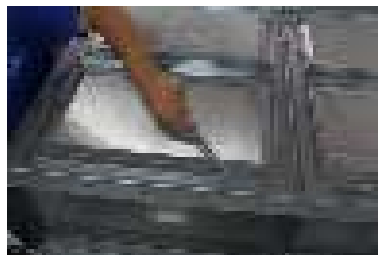

Before assembly, thoroughly clean the busbar contact area using a clean cloth with alcohol or a suitable solvent to ensure a good contact surface. Plated contact surfaces shall be cleaned using a branded liquid silver polish. After cleaning, all surfaces shall be wiped with a clean cloth to remove any metal dust, etc. Joints shall be assembled as soon as possible after preparation.



The same treatment of contact surfaces shall be carried out on all other joints, such as the tee-off to voltage transformers and main cable connections. For assembly of busbars refer to busbar layout drawings supplied with loose gear.

Hold the busbars in position as shown in the drawing for busbar joints.

Fix in place with bolts, washers and nuts as shown in the illustration.

For the time being tighten the bolts by hand only (use no tools) until all the busbars are aligned.

After alignment tighten the screw and nut to torque values as given in the table of Section 6.2.1



1250A BUSBAR RUN - (As seen from back for a typical 8 panel board)

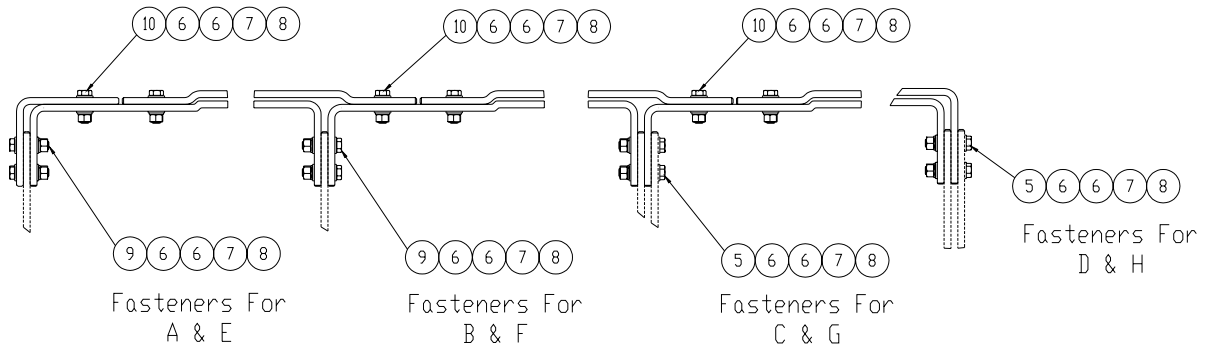
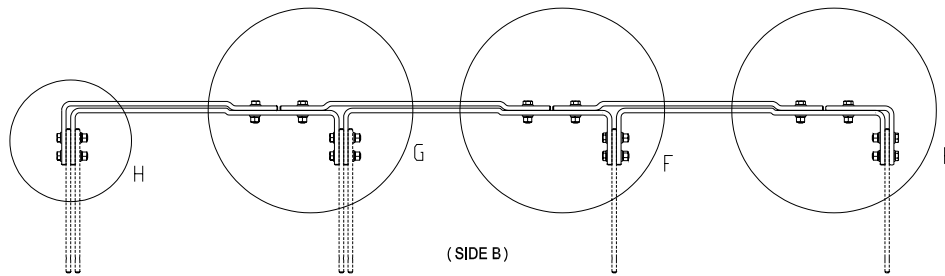
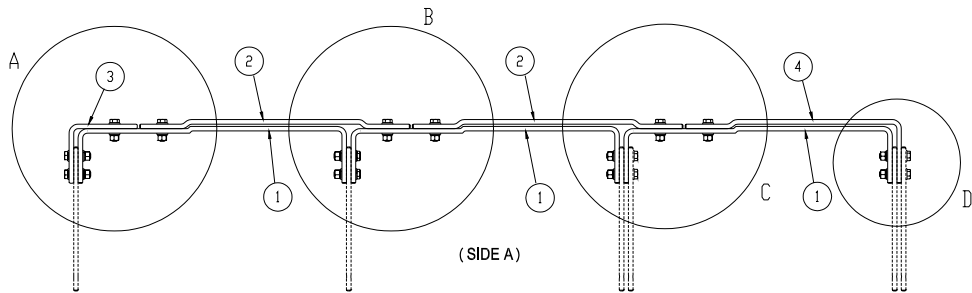
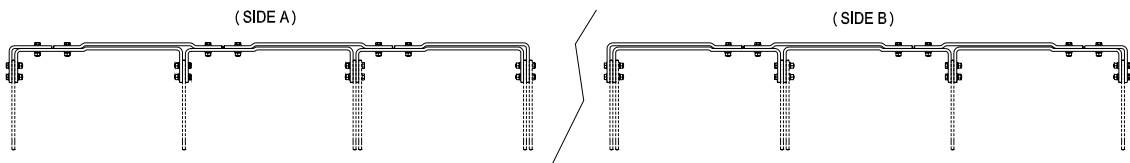

ITEM NO.	PART NUMBER	DESCRIPTION	Default/QTY.
1	NBHC0092AD	Copper Busbar	6
2	NBHC0093AD	Copper Busbar	4
3	NBHC0094AD	Copper Busbar	2
4	NBHC0091AD	Copper Busbar	2
5	IF40062HA40	M12X60 BOLT	8
6	IF2079HA18	M12 FORM A	56
7	IF2082HA118	M12 SPRING WASHER	28
8	IF0004HA13	HEX M12 NUT	28
9	IF40062HA36	M12X50 BOLT	8
10	IF40062HA32	M12X40 BOLT	12

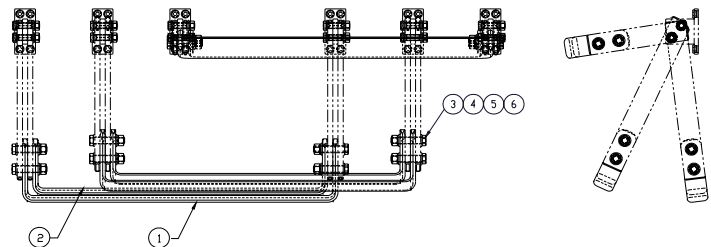

ITEM NO.	PART NUMBER	DESCRIPTION	QTY.
1	NBHC0054AD	Copper Busbar	3
2	NBHC0055AD	Copper Busbar	3
3	IF40062HA40	M12X60 BOLT	12
4	IF2079HA18	M12 FORM A	24
5	IF2082HA118	M12 SPRING WASHER	12
6	IF0004HA13	HEX M12 NUT	12

## 2000A BUSBAR RUN - (As seen from back for a typical 8 panel board)

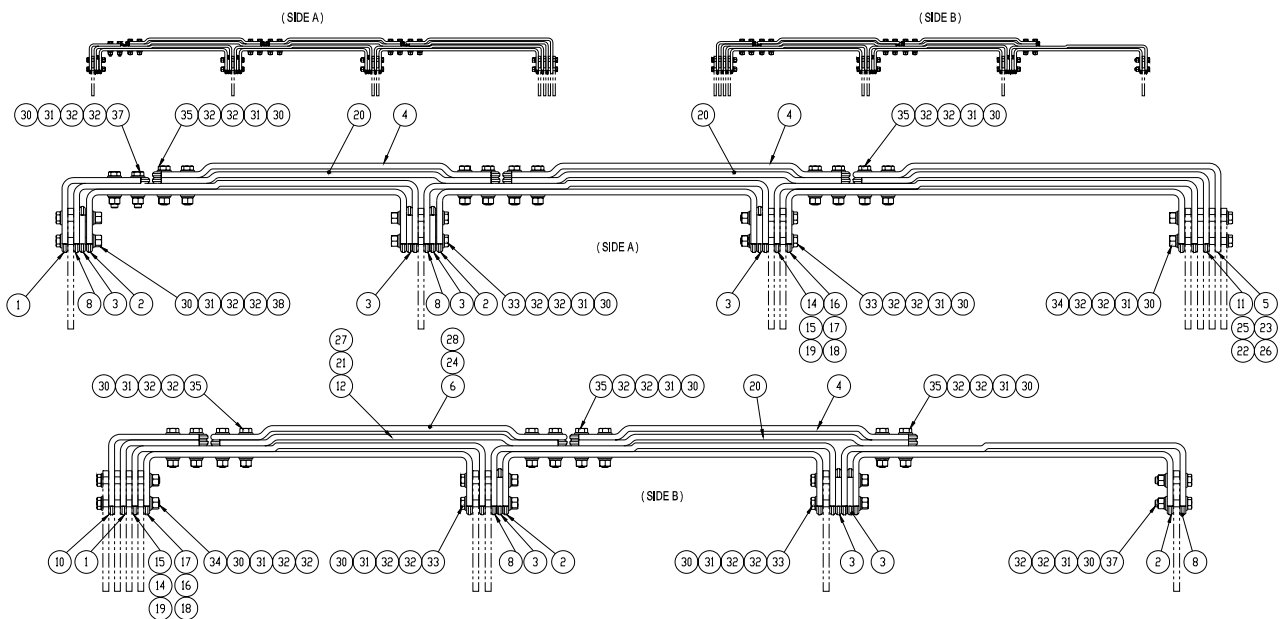

ITEM NO.	PART NUMBER	DESCRIPTION	R	Y	B	QTY.
1	NBHC0073AD	Copper Busbar	2	2	2	6
2	NBHC0058AD	Copper Busbar	4	4	4	12
3	NBHC0074AD	Copper Busbar	7	7	7	21
4	NBHC0082AD	Copper Busbar	3	3	3	9
5	NBHC0088AD	Copper Busbar	1			1
6	NBHC0085AD	Copper Busbar	1			1
8	NBHC0059AD	Copper Busbar	4	4	4	12
10	NBHC0081AD	Copper Busbar	1	1	1	3
11	NBHC0072AD	Copper Busbar	1			1
12	NBHC0067AD	Copper Busbar	1			1
14	NBHC0065AD	Copper Busbar	1		1	2
15	NBHC0063AD	Copper Busbar	1		1	2
16	NBHC0062AD	Copper Busbar	1		1	2
17	NBHC0060AD	Copper Busbar	1		1	2
18	NBHC0061AD	Copper Busbar		2		2
19	NBHC0064AD	Copper Busbar		2		2
20	NBHC0066AD	Copper Busbar	3	3	3	9
21	NBHC0068AD	Copper Busbar		1		1
22	NBHC0071AD	Copper Busbar		1		1
23	NBHC0084AD	Copper Busbar		1		1
24	NBHC0087AD	Copper Busbar		1		1
25	NBHC0070AD	Copper Busbar			1	1
26	NBHC0083AD	Copper Busbar			1	1
27	NBHC0069AD	Copper Busbar			1	1
28	NBHC0086AD	Copper Busbar			1	1
30	IF0004HA13	HEX M12 NUT	38	38	38	114
31	IF2082HA118	M12 SPRING WASHER	38	38	38	114
32	IF2079HA18	M12 FORM A	76	76	76	230
33	IF40062HA51	M12X90 BOLT	8	8	8	24
34	IF40012HA55	M12X100 BOLT	4	4	4	12
35	IF40062HA40	M12X60 BOLT	20	20	20	60
37	IF40062HA38	M12X55 BOLT	4	4	4	12
38	IF40062HA44	M12X70 BOLT	2	2	2	6

Riser panel busbar arrangement

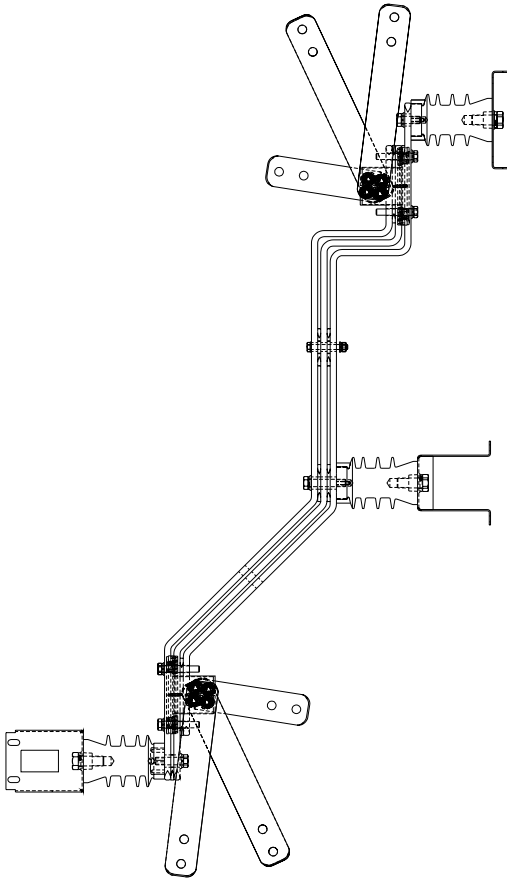

2000A

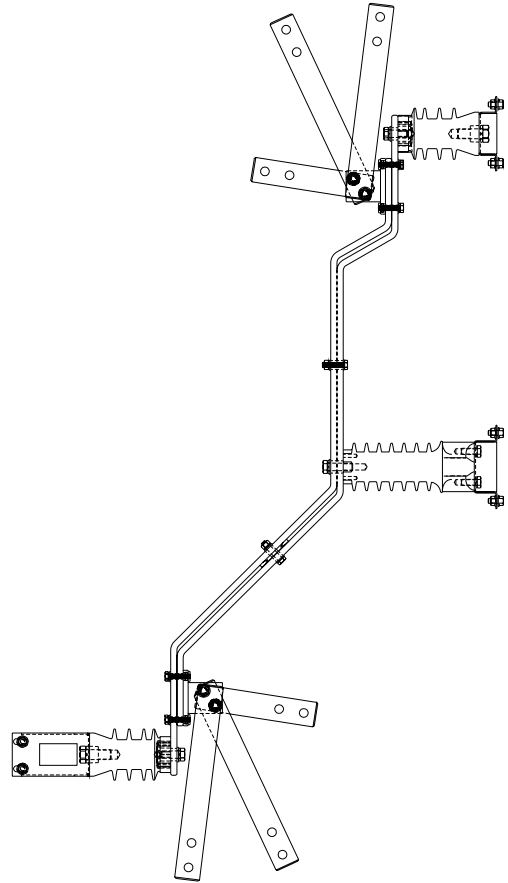

1250A

## 6.4 Unit earthing



The main earth bars of the units are preassembled within the unit. The only assembly required on site is, to connect the earth bars of adjacent units together using the interconnecting earth bar supplied with the unit. Make sure that the contact surfaces of the earthing busbar connections are perfectly flat, without any burrs, oxidation traces or deformations.

The earth bar must be terminated to the station earth system via the connection to the end unit earth protruding from the decorative end covers.

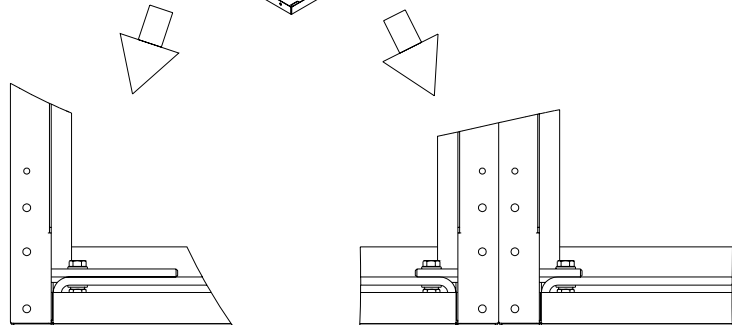
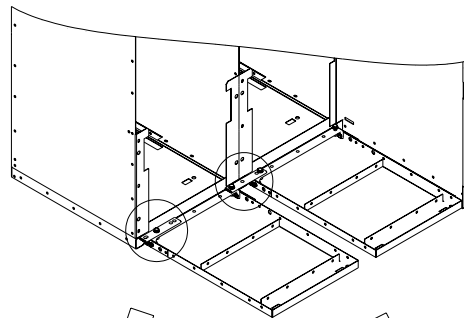
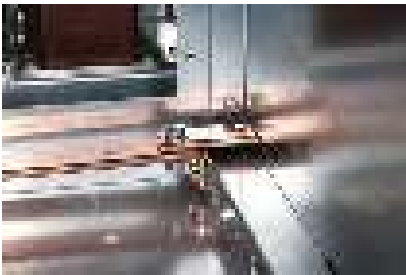

**NOTE:** The extreme unit earth bar for connection to the substation earth is supplied as loosegear.

## 6.5 Installation of Gas Compartment

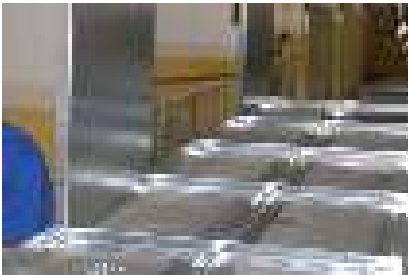

The installation room must be prepared according to the switchboard size and type and in line with the drawings supplied by Medelec Switchgear Ltd.

Compliance with the dimensions guarantees correct operation of the apparatus.

To allow for containerised shipments, the gas Compartment is flat packed and sent as loose material.

Assemble the gas Compartment for each unit starting from the central units and moving out.

- Assemble the front and rear covers. Ensure that the front and back supports are vertically aligned with the sides of the switchboard panel before tightening the screws.
- Install the top cover and fit the screws without tightening.
- Assemble the middle partition and tighten the screws.
- Install the two adjacent gas Compartments by repeating the above steps.
- Check the horizontal alignment of the three units and tighten the screws holding the top covers together and also those holding the top cover to the vertical supports.
- Continue assembly of the remaining gas Compartments as described above.
- Assemble the gas Compartment end covers according to the agreed configuration.
- Finally assemble the decorative covers on the rear and front of the gas Compartment.
- Finally fit the gas duct (not within Medelec scope of supply) to channel gases generated by an internal arc fault out of the substation building.



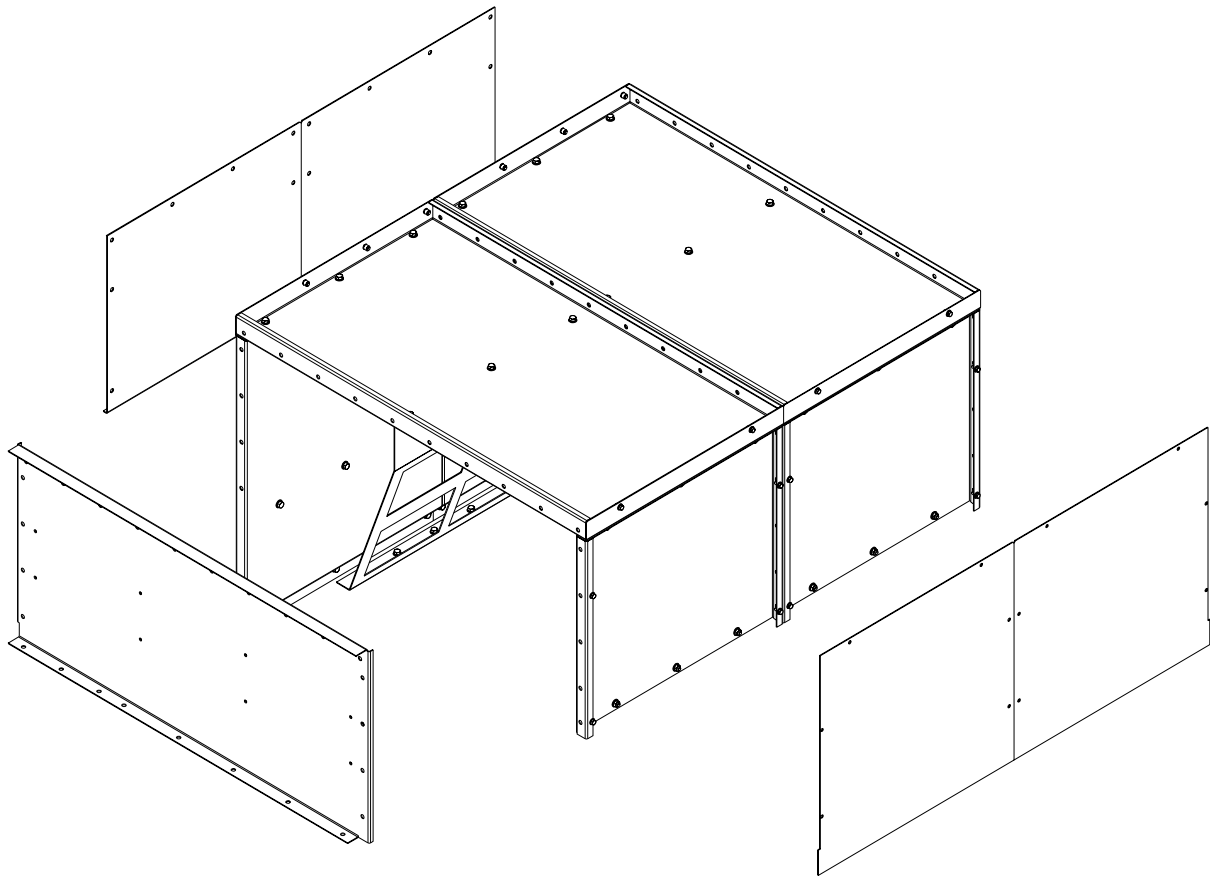

### 6.6 The gas duct

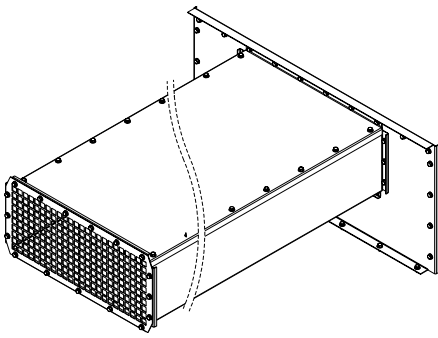

**NOTE:** All the necessary ducting to route the Internal Arc gases safely out of the substation are outside the scope of supply of Medelec Switchgear Ltd. Detailed drawings of the duct cross section and fixing holes location can be provided.

To guarantee safe operation, the duct extensions must be manufactured from galvanised sheet metal at least 2mm thick and manufactured according to the drawings provided by Medelec Switchgear Ltd.

In the case where bends cannot be avoided, these are to be constructed using the maximum radius possible. Each 1 meter section can be pre-assembled and then joined to the switchgear. Fit the units using the appropriate screws and tighten as per values given in Section 6.2.1. Once outside the switchgear room, the end has to be protected from water ingress and foreign objects. The duct outlet area must be adequately chosen to avoid risk of injury and damage to third party property. Adequate signs must also be placed at the duct exit.

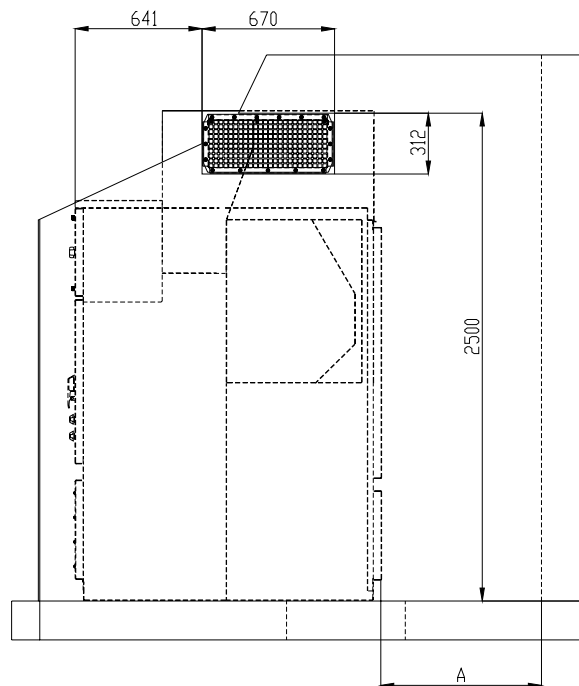
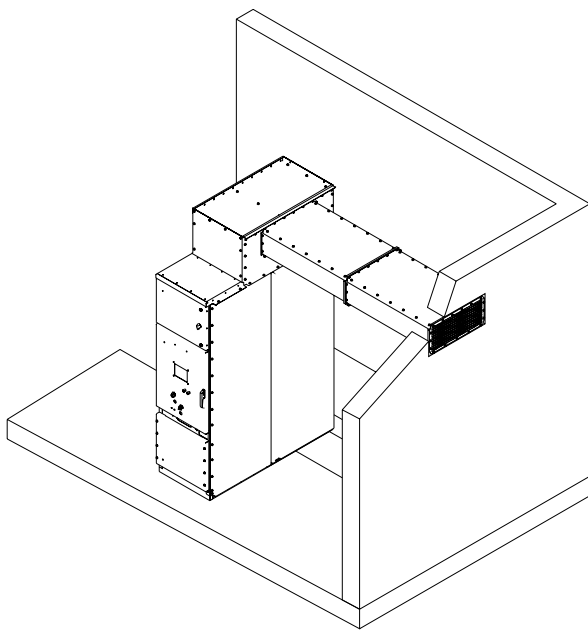

## 6.7 Connection of Inter-unit auxiliary wiring (Bus-wiring)



The only secondary wiring required on site is to run and terminate the inter-unit bus-wires in accordance with the wiring diagrams supplied. Auxiliary wiring for inter-panel connection is run from panel-to-panel through the dedicated auxiliary wiring duct on top of the Low Voltage Compartment.

Remove the auxiliary wiring duct cover and route the cables accordingly. For ease of connection, each wire is fitted with an identification ferrule, which corresponds with the markings on the terminal block. Open the doors of the low voltage compartment and terminate the wire ends in accordance with the bus wire diagram. Replace the duct cover once all wiring has been completed.

The loosegear contains a detailed wiring diagram for the secondary wiring and the inter-panel wiring (Bus wires).

## 6.8 Connecting the auxiliary multicore cables

Multicore cables can be routed either from the front bottom cutouts, from the rear bottom cutout or through the auxiliary wiring trough situated on top of the low voltage cubicle together with the bus wires.

### 6.8.1 Front bottom entry



Whenever auxiliary wiring is routed through a separate trench from the power cables, this must be located just behind the front switchgear fixing locations and underneath the auxiliary wiring entry cutouts.

Use the left entry cutout at the bottom front location. Remove the vertical wiring trough covers. Route the cables to the Low voltage cubicle tying them to the appropriate fixings to take the weight of the cable. Fit the wiring to the vertical terminal strip on the Left hand side of the Low voltage cubicle following the wiring diagrams supplied. Fit the wiring trough covers

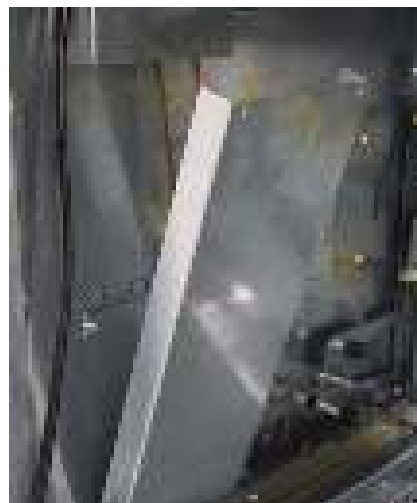

### 6.8.1 Rear bottom entry



In the case when the auxiliary cables are passed through the trench together with the power cables, use the left entry cutout at the bottom rear location. Remove the left hand horizontal wiring trough covers by loosening the front fixing screws and pulling out the trough and unscrewing the rear cover. Remove the left hand vertical wiring trough covers. Route the cables to the Low voltage cubicle tying them to the appropriate fixings of the vertical run to take the weight of the cable. Fit the wiring to the vertical terminal strip on the Left hand side of the Low voltage cubicle following the wiring diagrams supplied. Fit the wiring trough covers.

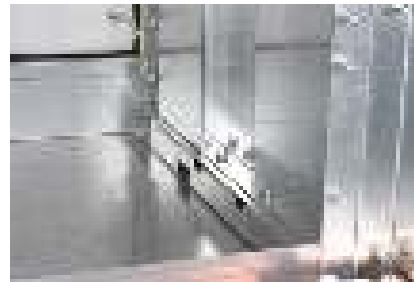

### 6.8.2 Low voltage wiring trough



If the auxiliary cables are passed inside cable trays hanging from the ceiling of the substation, these can be routed down through the auxiliary wiring duct on top of the Low Voltage Cubicle.

Open the top cover of the low voltage wiring trough on top of the low voltage cubicle. Remove the side cover of the wiring trough on the extreme end. Prepare the necessary holes for the glands/grommets according to the cable size. Feed the auxiliary cables and lay them on the low voltage cubicle to the relevant panel.

## 6.9 Power cable termination



Access to the main cable terminations is via removable covers at the rear of the housing or from the front of the panel (This is not advisable when a withdrawable VT is installed).



**Warning:** When carrying out installation or maintenance work inside the cable compartment ensure that cable is de-energised and earthed.

When rear access is possible, unscrew the bottom rear cover of the cable compartment. Access via the rear cover does not require any other disassembly. In the case where 2 sets of cables are to be terminated, start with the set towards the front of the unit and then move back.



For cable termination of wall mounted panels, access is from the front. Open the circuit breaker and VT compartment doors. Unscrew and remove the front horizontal stiffener below the circuit breaker compartment. Unscrew the clips, from this partition, holding the earth switch auxiliary wiring loom, and remove the partition. Remove the 4 screws holding the horizontal partition between the circuit breaker and VT/cable compartment.



When fixed VT's are installed, remove the wiring and the copper busbar connection. Remove the Fixed VT's (There is no need to remove the VT supporting frame) using the appropriate tools (See section 9.3.2.4). In this case start by terminating the set of cables further at the back and move forward when more than one set needs to be terminated.

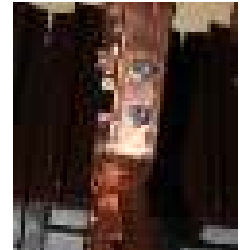
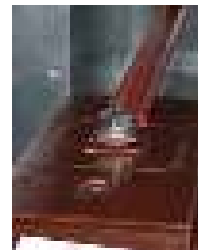

Choose the cable conductor section according to the rated normal current and to the short-circuit current of the breaker.



**NOTE:** The cables shall be terminated to the cable connection busbar using the fixing bolts which are not longer than necessary.

The **MSG™** switchgear can be supplied with the following cable entry configurations:

- up to 2 sets of 3 core 240sqmm cables
- up to 6 single core 400sqmm cables.

### 6.9.1 Cable supports and grommets for single core cables



The configuration as shown in the Figure below consists of a transversally split gland plate made from 3mm aluminium fitted with rubber grommets for vermin proofing and protection of the cable insulation. In order to relief strain from the copper busbar connections, the cables are supported and secured by cable clamps located inside the cable compartment. Terminate and connect the cable in accordance with the manufacturer's instructions.



Connect the earthing screen of the cable to the earth point provided in the cable box compartment.

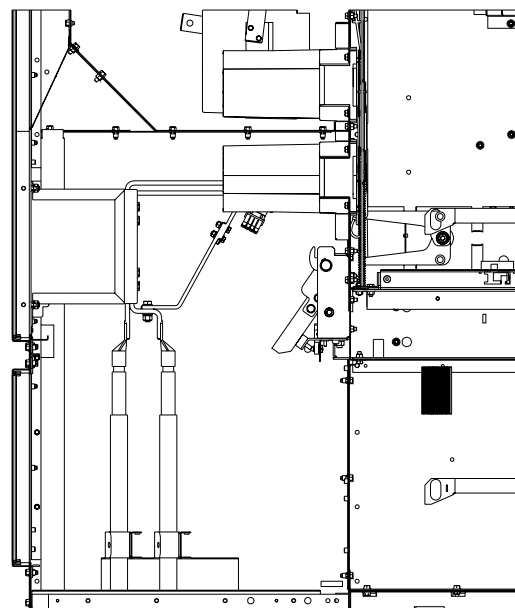
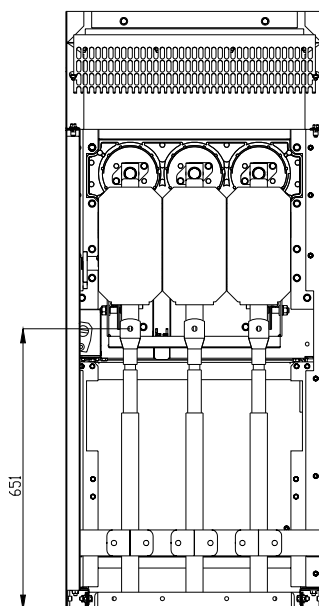

### 6.9.2 Cable gland for 3 core cables



The configuration as shown in the Figure below consists of a transversally split gland plate made from 3mm galvanized steel for fixing the cable gland. The 3 core cable is routed through the gland and terminated according to the applicable termination kit instructions.

The height of the cable box allows for the trifurcation to be located inside the same cable compartment.

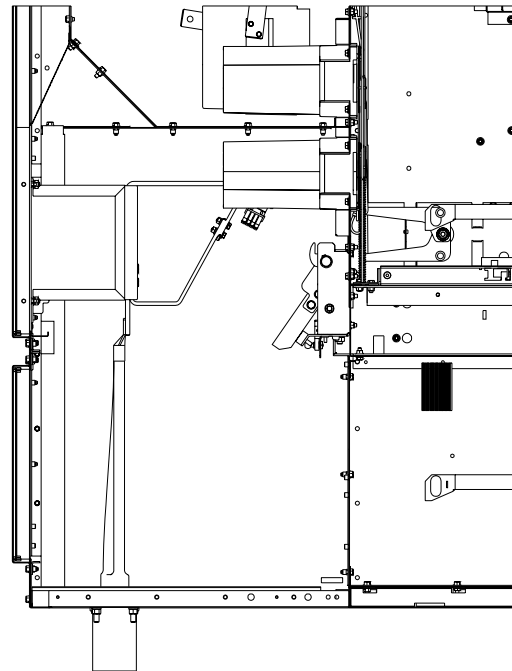
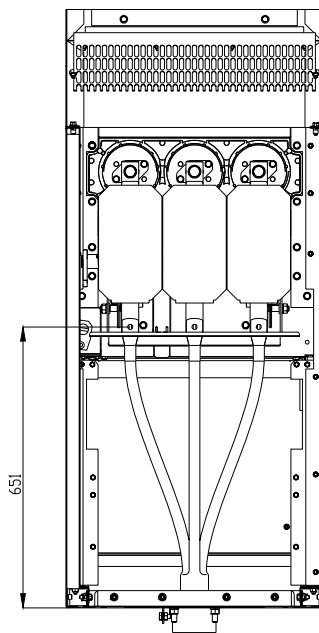

## 6.10 Installation of the decorative end covers



The decorative end covers on the **MSG** have two functions. Apart from providing an aesthetically appealing view of the switchboard, they are designed to absorb and dissipate the thermal and pressure shocks during an internal arc fault if this occurs in any one of the extreme units.



**CAUTION:** Proper assembly of the end covers is crucial to guarantee integrity of the panel during an internal arc fault.

Follow the assembly instructions below and refer to the drawing in the next pages for the fixing details.

- Assemble the busbar compartment end cover.
- Install the front flat galvanised steel sheet and fix it in position using the two central locations provided.
- Position the rear decorative end cover and fix with few screws.

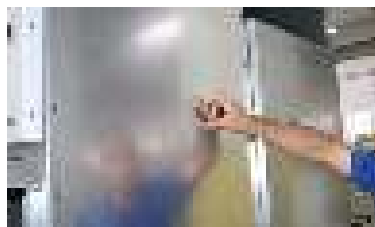



- Position the front decorative cover on top of the rear cover common fixing location and fix with few screws.
- When installing the substation earth connection, open the small shutter on the bottom of the rear decorative end cover and pass the copper bar through this opening.
- Set correct alignment of both covers and install and tighten all the screws.



**Warning:** The vertical middle row of screws is button head screws inserted from the inside. If this step is omitted and standard screws are used, the head of the screw will foul the shutter drive lever. This will prevent the shutter from closing properly and presents a safety hazard for the operators.

- Install the end exhaust gas compartment cover and fix all the screws around the top sides and bottom.
- Install the Auxiliary wiring duct top and end covers.
- Install the front and rear exhaust gas compartment decorative covers.



**A**  
 M8 x 20 Hex  
 Head rolling  
 screw and nut.  
 Inside      Outside



**B**  
 M8 x 20 Socket  
 button head  
 screw and nut.  
 Outside      Inside



**C**  
 M8 x 20 Hex  
 Head rolling  
 screw.  
 Inside      Outside

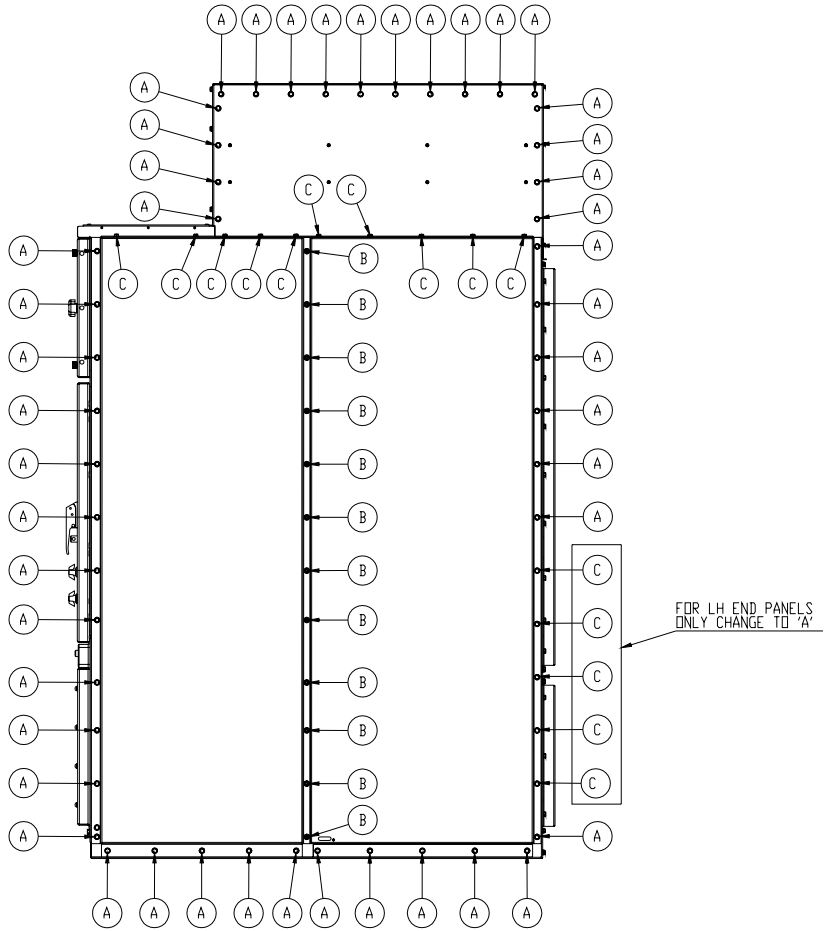
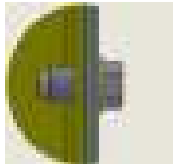

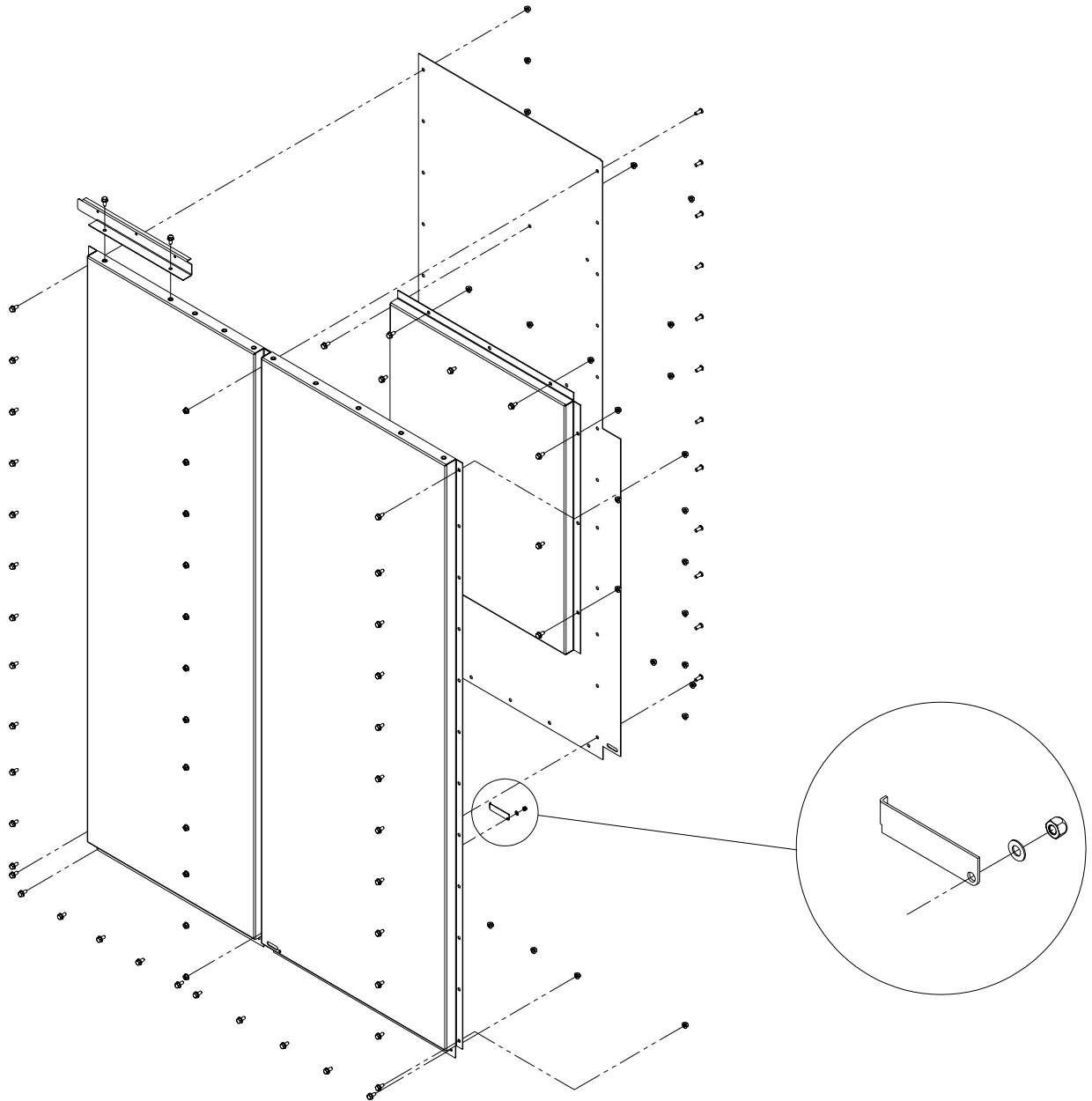

## 6.11 Installing the tool rack



The tool rack provided is used for two purposes:

- As a receptacle for the tools necessary to operate the switchgear.
- As a tool to assist removal of the fixed VT's from the lower chamber in case of maintenance.

The tool rack is installed close to the substation onto the adjacent wall by means of two hooks. Refer to adjacent photo.

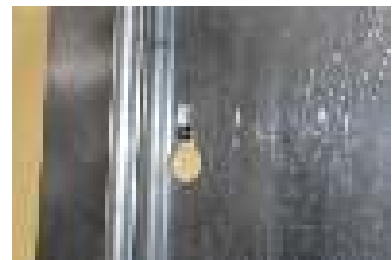
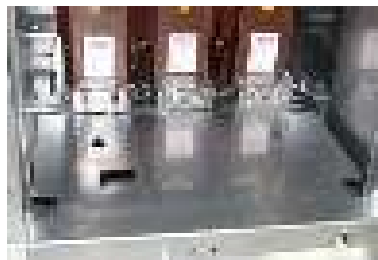

## 6.12 Aligning the door racking access hole to the circuit breaker drive

Once the panel installation is complete, the withdrawable units can be put inside the respective panels according to the relevant markings. Follow the procedures in Section 7.



During the first installation, check the alignment of the racking access hole to the circuit breaker drive. If these are not perfectly aligned, follow the instructions below:

For vertical alignment, slight variation may be adjusted by shifting the unit door vertically from the hinges. Mark the hinge - side frame position to use as reference for the necessary movement from the original position. Slacken the hinge screws and shift the door up or down accordingly. Tighten a couple of screws (ideally these should be the uppermost and lowermost screws) and check alignment. If OK, tighten all screws.

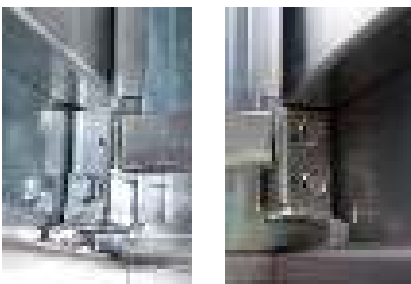

For horizontal alignment, slightly slacken the front screws of the circuit breaker guides. Shift the guides horizontally until the racking hole aligns with the circuit breaker drive. Tighten the guide screws.

### 6.13 Final check

When the installation is ready ensure that the switchboards are clean and free from any loose material such as fasteners, cable ties, loose cables, etc..

Also check that the panels have not been damaged or deformed during the installation process.

Ensure that all screws have been installed and tightened as per the recommended torque settings in section 6.2.1.

### 6.14 Circuit name label



The circuit breaker door of each unit has a blank label attached just above the viewing window. This serves to write or engrave the name of the particular circuit once connected and energised.

### 6.15 Extending the switchboard

In the case when the switchboard needs to be extended, the end covers are removed, and the last leg of the busbar run slackened. The end pieces on the busbar run are removed for subsequent use on the newly installed end unit. Follow the same procedure for unit installation as described in section 6.2. Fit the busbar as per instruction in section 6.3 using the supplied material and the busbar end piece removed previously. Install and connect the unit earthing as per Section 6.4 and complete the installation following procedures in sections 6.5 to 6.10. Carry out any necessary alterations to the substation wiring as required.

## 7 Operation



**WARNING:** Interlocks must only be removed by authorized personnel, and only if absolutely necessary for operational reasons. When removing an interlock, the operator must take special and adequate safety measures to prevent situations, which might have fatal consequences.



**CAUTION:** The switchgear must be operated only as described in this manual and instructions must be followed exactly.



**CAUTION:** Only qualified operators may operate the equipment.

### 7.1 Operating Accessories

The following operating accessories are required for the normal operation of the switchgear.

- 1 Circuit breaker spring charging-lever.
- 2 Operating rod for circuit breaker operation with door closed.
- 3 Key locks.
- 4 Circuit breaker and VT racking in/out lever.
- 5 Earthing switch operating lever.

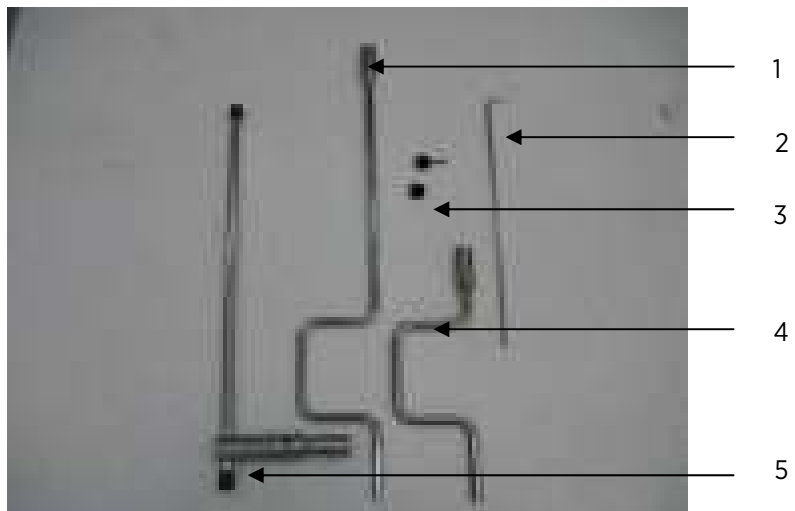

## 7.2 Circuit breaker positions

The circuit breaker can be in any one of three positions as already highlighted in section 3.2.1.



**CAUTION:** The breakers are fitted with interlocks to prevent them from being inserted or withdrawn at the wrong time or in the wrong place. A special hand crank is provided to rack the breaker inside the circuit breaker compartment.



**NOTE:** In the removed position, the breaker is handled by a dedicated transportation trolley which is also used during the insertion or complete removal of the breaker into or out of the panel.

### 7.2.1 Removed position



In the removed position the circuit breaker is outside of the panel, mounted on the transportation trolley and ready for insertion into the panel. The secondary plug is unplugged.

In this position it is possible to complete a functional test on the circuit breaker in the removed position with the use of an optional extension umbilical cable which connects the secondary plug of the circuit breaker with the stationary secondary socket inside the busbar Compartment. In this position the shutters are closed and can be padlocked for additional safety.



**NOTE:** Ensure that any padlocks that have been used to lock the shutters have been removed before the circuit breaker is inserted.

### 7.2.2 Isolated/ test position



In the isolated/test position the circuit breaker is in the circuit breaker compartment and located just behind the door of the compartment. The circuit breaker has not yet made contact with the main contacts. In this position the shutters are closed, and the secondary plug can now be connected.

The earthing switch can be operated with the door open or closed when the circuit breaker is in the isolated/test.

The circuit breaker can only be put into the Service position when the earthing switch is in the open position, the compartment door is closed, secondary plug connected and interlocked, any padlocks removed and all mechanical and electrical interlocks are satisfied.

The circuit breaker can be moved (racked in) from the isolated/test position to the Service position by means of the appropriate handle.

Any padlocks fitted to the shutter mechanisms should have been removed prior to insertion in the isolated/test position.

In the isolated/test position, the circuit breaker can be operated electrically and mechanically with the door open.



**NOTE:** If the shutter padlocks have not been removed and the circuit breaker is forcibly racked in damage may be caused to the shutters and / or the carriage mechanism.

When the breaker is Closed, it cannot be moved either into the service or out to the isolated/test position.

### 7.2.3 Service Position



In this position, the circuit breaker is fully inserted and the hand crank has been removed. Racking of the breaker into this position can only be carried out with the circuit breaker door closed.

The earthing switch cannot be operated when the breaker is in the service position.

The door of the compartment cannot be opened with the unit in the Service position.

The unit is now fully operational.

### 7.3 Inserting the Circuit breaker into the panel from the removed position



**CAUTION:** Should any operation be carried out while the circuit breaker is withdrawn from the switchboard, pay the utmost attention to the moving parts.



**NOTE:** The circuit breaker must be inserted into the unit only in the open position.



**NOTE:** The racking in/out operation must be gradual, so as to safeguard the mechanical interlocks against any deforming impacts.



1. Open the door of the circuit breaker compartment.
2. Check that there are no padlocks fitted on the shutters. Remove them if fitted.
3. If the panel has an earthing switch, make sure it is in the required position. (Open during normal operation, Closed during maintenance or testing).
4. Remove all locks in accordance with any specific operating instructions.
5. Check that the circuit breaker is Open.
6. Move the trolley up to the circuit breaker compartment. Align the interlocking tabs with the holes in the front panel and secure the trolley to the front of the panel.
7. If the panel is not flush with the substation floor, prepare wooden boards of the required thickness in front of the panel to compensate for the height difference.
8. Unlock the circuit breaker from the trolley by pressing the handles at the front of the truck towards the centre and push the circuit breaker into the panel.





9. When the front of the circuit breaker truck is aligned with the panel guides, release the handles and move the circuit breaker until the locking pins latch. The circuit breaker is now mechanically coupled to the compartment.
10. Unlock the trolley and remove.



**NOTE:** If the circuit breaker handles are not properly latched, circuit breaker racking is not possible



**NOTE:** In this position, circuit breaker racking is not possible if the secondary plug is disconnected.



11. Insert and mount the secondary plug in the enclosure fixed socket. Lock the secondary plug by pushing on the plastic handle.
12. Turn the secondary interlock lever clockwise.
13. The circuit breaker is now in the isolated/test position.
14. Close the compartment door in preparation for circuit breaker racking.
15. During the first insertion, check the vertical and horizontal alignment of the racking access hole with the circuit breaker truck drive. This is usually set during factory assembly but might require some adjustment in case of either replacement of the withdrawable part or distortion of the unit during transport or assembly. (See Section 6.12)



**NOTE:** The secondary plug interlock handle cannot be rotated with the plug disconnected.



**NOTE:** Circuit breaker racking is only possible with the secondary plug interlock handle rotated in the horizontal position.



## 7.4 Racking the circuit breaker from the isolated/test position to the service position



**CAUTION:** Do not remove the circuit breaker covers. In case of need, keep at a safe distance during apparatus opening and closing operations to avoid any contact with moving parts.



**NOTE:** Apart from the interlocks described above, other interlocks may be present depending on the options chosen.



**NOTE:** It is only possible to rack the circuit breaker from isolated/test position to service position with the circuit breaker door closed.



**NOTE:** The operations must be carried out using normal force (not more than 260 N), only using the special tools (see section 7.1). If the operation is prevented, check that the operating sequence is correct.



1. Make sure that the secondary plug interlock lever is fully turned in the horizontal position to lock the plug.
2. Check that the circuit breaker is OFF.
3. If there is an earthing switch on the panel, ensure it is switched OFF and the shutter on the earthing switch drive is completely closed (See Section 4.1.9).
4. Close the panel door of the compartment.
5. Turn the knob located in the centre bottom of the door clockwise until the operating hole is exposed. (Provided that there are no interlocks or keylocks which block the insertion of the racking handle).
6. Remove any keys from the shutter knobs.
7. Fit the short hand crank handle in the drive shaft and push to unlock the anti-racking mechanism.
8. Keep this push on the handle and rotate clockwise until the circuit breaker is fully inserted.
9. Remove the hand crank by rotating the knob clockwise whilst withdrawing the handle out of the circuit breaker door.
10. Release knob and ensure that the shutter returns to the fully closed position.
11. The circuit breaker is now locked in the Service position and is fully operational.
12. The compartment door cannot be opened.



**NOTE:** Ensure that the circuit breaker is in the fully racked position. If not, operation of the switch is not possible.



**NOTE:** Ensure that the racking handle shutter is fully closed.

## 7.5 Withdrawal from service to isolate/test position

1. Check that the circuit breaker is OFF.
2. Turn the knob located in the centre bottom of the door clockwise until the operating hole is exposed. (Provided that there are no interlocks or keylocks which block the insertion of the racking handle).
3. Fit the short hand crank in the drive shaft and push to unlock the anti-racking mechanism.
4. Keep this push on the handle and rotate anti-clockwise until the circuit breaker is fully withdrawn.
5. Remove the hand crank by rotating the knob clockwise whilst withdrawing the handle out of the circuit breaker door.
6. Release knob and ensure that the shutter returns to the fully closed position.
7. The circuit breaker is now in the isolated/test position and the door can be opened.

## 7.6 Removal of the circuit breaker from the panel

This is the reverse operation to the procedure in Section 7.3.

1. Check through the viewing window of the door that the unit is in the isolated/test position and the breaker is OFF.
2. Open the unit compartment door.
3. Release the secondary plug interlock by turning lever anticlockwise until the handle is in a vertical position.
4. Remove the secondary plug and fit it to the breaker.
5. Place the trolley in front of the panel and ensure that the trolley is fully locked to the front of the panel.
6. If the panel is not flush with the substation floor, prepare wooden boards of the required thickness in front of the panel to compensate for the height difference.
7. Push the handles on the front of the circuit breaker truck towards the centre of the breaker and pull to move the unit onto the trolley.
8. Release the handles and move the truck until the locking pins latch with the trolley.
9. Unlock the trolley and remove from the switchboard.
10. If necessary fit a padlock to the automatic shutters see Chapter 7.7.
11. Close the circuit breaker door.

## 7.7 Padlocking the shutters



It may be necessary for safety reasons to lock the shutters when the unit has been withdrawn from the panel.

To do this, the shutter mechanism can be secured with a padlock. The maximum size of the padlock hasp is 8mm diameter.

To install the padlock, proceed as follows:

1. Remove the circuit breaker from the unit by following procedure 7.6.
2. Check that the shutters are closed properly.
3. Install the padlocks in the locations shown in the photo.

## 7.8 Operating the circuit breaker in the isolated/test position with door open



All mechanical and electrical operations on the circuit breaker can safely be carried out with the circuit breaker in the isolated/test position, compartment door open and secondary plug connected. Refer to circuit breaker details in section 3.2.1



**CAUTION:** When performing mechanical operations on withdrawn circuit breakers pay the utmost attention to the moving parts.



**NOTE:** Should the operations be prevented, do not force the mechanical interlocks but check that the operation sequence is correct.

### 7.8.1 Spring charging

Spring charging can be carried out both with door open and circuit breaker in the isolated/test position or with doors closed, with the circuit breaker in the service position.

- For manual charging refer to Section 7.9.1
- For electrical charging refer to Section 7.10.1

### 7.8.2 Circuit breaker closing



The operation can only be performed when the closing springs are fully charged and any interlocks included are satisfied.

For manual closing, push the green ON button.

The circuit breaker closes and the position indicator on the breaker indicates that the breaker is in the Closed position.

### 7.8.3 Circuit breaker opening

For manual opening push the red OFF button.

The unit switches OFF and the position indicator on the breaker indicates that the breaker is in the OFF position.

## 7.9 Operating the circuit breaker in the service position with door closed



**WARNING:** Opening and closing operations with the withdrawable part in the service position should only be performed with the door closed.

When the door is closed, the circuit breaker can be manually switched ON or OFF by inserting the special rod through the special guides on the front of the compartment door.



**NOTE:** If you are not sure whether the switch is working properly, carry out the following procedure:

- Look through the window in the door and check to see if the switch is in the service or isolated/test position.
- The switch should be fully racked in the service position. Check that spring position indicator on the switch is in the 'spring charged' position.



**NOTE:** The door cannot be opened when the switch is in the service position.

The switching operation counter for the circuit breaker automatically increases by one unit with each operating cycle.

### 7.9.1 Manual spring charging



Circuit breakers are equipped with charging motors as standard supply. Electrical charging is carried out automatically if auxiliary supply is ON.

If the auxiliary supply to the motor should fail or is not available, the charging procedure can be carried out manually. Charging can be done either with the door open and the breaker in the Isolated/test position or with the door closed when the breaker is in either the isolated/test position or the Service position.

For manual spring charging, fully insert the long charging lever into the spring charging access hole after opening the applicable shutter located on the right hand side of the circuit breaker compartments door. (Omit the above step if the door is open.) Locate the handle into the circuit breaker spring charge drive and turn the handle clockwise or anticlockwise. The circuit breaker drive mechanism is cam operated therefore charging force needs to be applied over a segment of the rotation. It requires approximately 8 rotations of the handle to fully charge a breaker. The completion of the charging procedure is audible and the yellow indicator appears on the fascia of the breaker. When the charged condition is reached, the charging mechanism is locked.

The standard force to be applied to the charging lever is 160N, the maximum value is 300 N. Any further force of the lever could damage the mechanism.

If the mechanism is not fully charged, manual and electrical closing of the breaker is not possible.



### 7.9.2 Manual switching ON with door closed



The operation can only be performed when the closing springs are fully charged and any interlocks included are satisfied.

For manual closing, Insert the operating rod through the front panel guides and press firmly on the "ON" green button. The unit switches ON and the position indicator on the breaker indicates that the breaker is in the ON position.

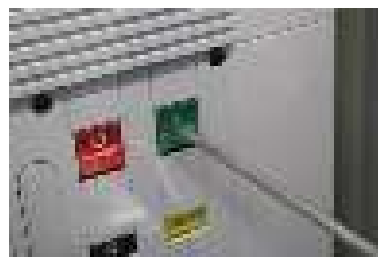

### 7.9.3 Manual switching OFF with door closed

For manual opening insert the operating rod from the front panel and press firmly on the “OFF” red button. The unit switches OFF and the position indicator on the breaker indicates that the breaker is in the OFF position.

## 7.10 Electrical Operation

The circuit breaker can be electrically operated from the Low Voltage control panel door.

The circuit breaker can also be electrically operated by remote control.

The circuit breaker can be switched ON and OFF in both the service and the isolated/test position, however the secondary plug must be connected to allow for electrical operation of the units.

Optional electro-mechanical interlocks can be fitted to ensure that the breaker cannot be operated ON or OFF or racked IN and OUT without the secondary plug connected.



### 7.10.1 Electrical spring charging

The circuit breaker is equipped with a gear motor for automatic spring charging.

The gear motor automatically charges the springs after a closing operation until the yellow indicator appears.

Should the power fail while charging, the gear motor stops and automatically restarts spring charging when the power is restored.

In any case, spring charging can be manually completed.

The circuit breaker is also equipped with a spring charged electrical indicator which will prevent remote closing if the mechanism is not fully charged.

### 7.10.2 Switching ON



**CAUTION:** Opening and closing operations with the withdrawable part in the service position should only be performed with the door closed.

- Operate the local or remote electrical control, by pressing the RED button or operate through the controls of the protective device installed.
- Observe the switch position indicator – The RED indicator lamp should light up and the mechanical indicator on the breaker should indicate that the switch is ON.
- The switching operation counter for the circuit breaker automatically increases by one unit with each operating cycle.
- The circuit breaker spring mechanism is automatically re-charged and the indicator on the switch should indicate that the mechanism springs are charged.

### 7.10.3 Switching OFF



**CAUTION:** Opening and closing operations with the withdrawable part in the service position should only be performed with the door closed.

- Operate the local or remote electrical control, by pressing the GREEN button or operate through the controls of the protective device installed.
- Observe the switch position indicator – The GREEN indicator lamp should light up and the mechanical indicator on the breaker should indicate that the switch is OFF.

## 7.11 VT Compartment

### 7.11.1 Withdrawable VT



**WARNING:** Putting the VT truck in and out of service must be carried out with the door closed.

Refer also to the Circuit breaker insertion procedure section 7.3

#### 7.11.1.1 Inserting the truck into the compartment



1. Open the lower Compartment (in case of a feeder VT) or Circuit breaker compartment (in case of busbar VT) door.
2. Move the VT truck on its trolley to the front of the panel compartment.
3. Move the trolley up to the relevant compartment. Align the interlocking tabs with the holes in the front panel and secure the trolley to the front of the panel.
4. If the panel is not flush with the substation floor, prepare wooden boards of the required thickness in front of the panel to compensate for the height difference.
5. Unlock the VT truck from the trolley by pressing the handles at the front of the VT truck towards the center and push the VT assembly into the panel.
6. When the front of the VT truck is aligned with the panel guides, release the handles and move the VT until the locking pins latch. The withdrawable VT is now mechanically coupled to the compartment.
7. Unlock the trolley and remove.
8. Insert and latch the two secondary plugs into the enclosure fixed sockets. Lock the secondary plugs by pushing on the metallic handles.
9. Close the compartment door.



**NOTE:** If the withdrawable part handles are not properly latched, racking is not possible

The removal operation is similar to steps 1 to 9 above except that the operations described in 5 and 6 are carried out in reverse and the secondary plugs are detached before removal of the VT truck.

### 7.11.1.2 Racking the VT truck to the service position



**CAUTION:** It is only possible to rack the VT truck to Service position with the VT door closed.



**NOTE:** The operations must be carried out using normal force (not more than 260 N), only using the special tools (see section 7.1). If the operation is prevented, check that the operating sequence is correct.



1. Make sure that the secondary plugs are inserted.
2. Close the panel door of the compartment.
3. Turn the knob located in the centre bottom of the door anti-clockwise until the operating hole is exposed (remove the key if inserted).
4. Fit the short hand crank handle in the drive shaft and push to unlock the anti-racking mechanism.
5. Keep this push on the handle and rotate clockwise until the VT truck is fully inserted.
6. Remove the hand crank by rotating the knob anti-clockwise whilst withdrawing the handle out of the VT compartment door.
7. Release knob and ensure that the shutter returns to the fully closed position.
8. The VT truck is now locked in the Service position and is fully operational.

Withdrawal from the service position is according to steps 1 to 8 above except that the handle has to be rotated anti-clockwise.

## 7.12 Earthing

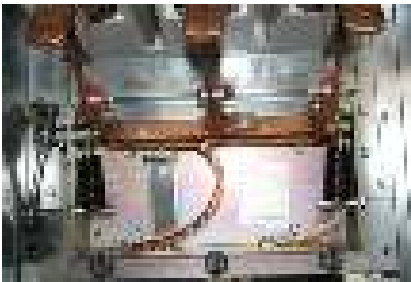

**WARNING:** Only authorized personnel may switch ON or OFF an earthing switch.



**CAUTION:** Do not attempt to operate the earthing switch when the (optional) earth switch electromechanical interlock is activated (de-energised) as the earth switch will not operate and using excessive force may damage the interlock mechanism.

The earthing switch can be used to.

- Earth a cable - When installed on feeder units.
- Earth a busbar - When installed on bustie and measurement panel.

The earthing switch can only be operated when:

- The Breaker is in the removed or isolated/test position.
- The earthing switch electro-mechanical interlock is not activated (energised).
- The earthing switch key lock is disabled. Standard supply is the earth switch key lock in ON position. Optionally panels can be ordered with key lock in OFF position.



**WARNING:** Make the necessary provisions on both sides of the cable before switching ON the earthing switch.



**WARNING:** Before removing cable cover make sure that the earthing switch is in the ON position (i.e. the cables earthed).



**WARNING:** In the case where remote feeder signal cannot be obtained or depending on client specifications, the electromechanical lock can either be supplied and permanently energised from the Low Voltage Compartment or not supplied at all. This will permit operation of the earthing switch irrespective of feeder supply status. It is therefore important that operator ensures that either cables are de-energised before switching the earthing switch or provide a signal to the electromechanical lock to control operation depending on supply status.



### 7.12.1 Switching ON the earthing switch



1. Put the breaker in the isolated/test position or completely remove the breaker.
2. Open the dust proof cover.
3. Disable the key if fitted to the earth switch operating mechanism.
4. Rotate the earthing switch interlock/shutter handle anti-clockwise to reveal the mechanism drive.
5. Insert the operating handle through the opening to engage the operating shaft of the earthing switch.
6. Turn the handle clockwise.
7. The handle will turn freely for the first quarter turn if there are no interlocks. If the handle is stiff to rotate during the first quarter turn than either the electromechanical interlock (see section 4.1.9) is engaged or the mechanism is jammed.
8. On reaching the end of the first quarter turn, the actual operating range of the handle is reached. Full operation is achieved in the next quarter turn.
9. The earthing switch switches ON.
10. The position indicator indicates "I" (ON).
11. It is not possible to put a withdrawable unit in the circuit breaker Compartment in the Service position with the earth switch ON.
12. Remove the operating handle.
13. The cover can now be closed, and if required, the mechanism can be locked in the "ON" position.



### 7.12.2 Switching OFF the earthing switch

1. Open the dust proof cover.
2. Release the key lock, if activated.
3. Insert the operating handle in the drive shaft of the earthing switch.
4. Turn the handle anti-clockwise.
5. The handle will turn freely for the first quarter turn if there are no interlocks. If the handle is stiff to rotate during the first quarter turn than either the electromechanical interlock is engaged or the mechanism is jammed.
6. On reaching the end of the first quarter turn, the actual operating range of the handle is reached. Full operation is achieved in the next quarter turn.
7. The earthing switch is switched OFF.
8. The position indicator indicates "O" (OFF).
9. Remove the operating handle.
10. Rotate the earthing switch interlock/shutter handle clockwise to cover the mechanism drive.
11. Close the dust proof cover.

The withdrawable circuit breaker can now be inserted in the service position.

### 7.12.3 Optional Voltage Detection System VDS



The low voltage control panel may be fitted with a cable voltage indicator. These may vary in functionality as follows.

#### 7.12.3.1 Voltage Indicator

This is the standard equipment installed on the  switchgear. A voltage indicator is an indicator with three LED's and three socket contacts L1, L2 and L3. It is connected via a signal cable to a voltage sensor, which is located on the current transformer or special post insulators.

Each LED monitors one phase. The LEDs light up if a voltage is present on the phases. If the phases are dead the LEDs do not light up.

#### 7.12.3.2 Live line cable interlock.

As an option, the  can be fitted with a live line cable interlock. In this case the voltage indicator will operate a relay which can be used to electrically interlock other functions such as cable earthing.

For details refer to the specific user manual for the device fitted.

## 8 Commissioning checks and test programme

After the switchgear has been installed and all connections have been completed, it is recommended to perform the following commissioning tests. The purpose of these tests is to confirm that transportation and storage have not damaged the circuit breaker or any part of the fixed portion.

The purpose of the commission tests is to confirm:

- Absence of damage.
- Compatibility of separate units.
- Correct assembly.
- Correct operation of the assembled unit.

The tests outlined in this section are to be performed after the equipment has been erected, but before energising.

### 8.1 General checks

- Check that the assembly has been performed to manufacturer's drawings and instructions.
- Check that the internal insulation components are undamaged and clean.
- Check adequacy and integrity of the earth connection up to and including the interface with the substation earthing system.
- Check all mechanical interlocks and free movement of the withdrawable units.(Circuit breakers and Withdrawable VTs)
- Check panel to panel wiring to confirm that it is according to specifications and drawings.
- Check the alignment of the racking access hole on the relevant door to withdrawable device racking drive as per procedure in section 6.12.

## 8.2 Electrical tests



**NOTE:** To check the electrical operation, auxiliary supply to the switchgear has to be provided.

Ensure that the following checks have been carried out:

- Electrical closing and opening of circuit breaker at rated auxiliary voltage.
- Operation of auxiliary contacts, relays, coils and meters.
- Perform wiring checks as per supplied drawings.
- Check the contact resistance of the primary circuit.
- Check the voltage drop on the busbar connections fitted on site.
- Perform a withstand voltage test of the secondary circuit. (Except the spring charging motors and electronic equipment).
- Perform a withstand voltage test of the primary circuit except the Voltage Transformer.

Check the integrity of the vacuum interrupters. Should a breakdown occur, the circuit breaker should be kept out of service and the matter reported without delay to Medelec Switchgear Ltd.

(The integrity of the vacuum interrupters can be checked on site by applying a test voltage of 20kV AC r m s or 30kV DC for 2 or 3 seconds across the open contacts of each phase with the other side earthed. Provided that there is no evidence of breakdown the interrupter is in a satisfactory condition).

## 8.3 Mechanical Tests

Manual operational checks should be carried out on the circuit breaker to ensure correct operation of interlocks, primary connection safety shutters, operating mechanism, trips, auxiliary switches, manual spring charging and the circuit breaker racking mechanism.

The equipment should be given a final inspection before it is put into service.

- Check that all panel-to-panel fixings have been installed and secured.
- Check that all covers are in place and fully secured.
- Check earth bars for continuity.
- Check that all fuses and links are inserted.
- Check that padlocks are fitted.
- Check all moving parts of the safety shutters, the circuit breaker racking mechanism, the isolatable voltage transformer operating mechanisms and all interlocks.
- Ensure all insulation surfaces are clean and dry.
- Touch up paint work where necessary.

## 8.4 Recording

In order that a complete history is available, records should be started immediately after erection.

Record the circuit breaker operations counter reading.

- Record the number on the operations counter at delivery.
- Record the number on the operations counter at first energisation.

Records are of value in establishing the frequency of maintenance, therefore careful notes should be taken of relevant events (such as short circuit operations) each time maintenance is carried out. These readings can be logged in the table under Section 8.6

In order that a complete history is available, records should also be taken immediately after commissioning and during particular events. These should include:

- Date of Completion.
- Details of any work carried out.
- Event log and details of repair or maintenance work carried out.

## 8.5 Check Lists

### A: COMMISIONING CHECK LIST

A 1	Equipment bolted down correctly.		
A 2	Instrument panels straight and aligned.		
A 3	All rubber gaskets and covers in place.		
A 4	Check tightness of all fastenings.		
A 5	All insulators undamaged and clean.		
A 6	Earth strap connections.		
A 7	Labelling.		
A 8	Switchgear Heaters.		
A 9	Isolating and Earthing Arrangements.		
A 10	Circuit breaker and Mechanism Alignment.		
A 11	Auxiliary Switches.		
A 12	Voltage and current transformers checked.		
A 13			

### B: Battery Checks:

B 1	Battery charged.		
B 2	DC available throughout switchboard.		
B 3	All fuses checked.		
B 4	Battery disconnection links left in open/close position.		
B 5			

### C: ELECTRICAL TESTS

C 1	High voltage tests carried out.		
C 2	Primary and secondary injection tests carried out.		
C 3	Main busbar voltage drop test carried out.		
C 4	Meters and relays checked by secondary current injection and supply voltage		
C 5			

Remarks:

.....  
 .....  
 .....

TESTS CARRIED OUT BY: ..... DATE: .....

TESTS WITNESSED BY: .....

EQUIPMENT ENERGISED: ..... DATE: .....



## 9 General Maintenance

Maintenance serves to preserve trouble-free operation and achieve the longest possible working life of the switchgear. It comprises the following closely related activities:

**Inspection:** Determination of the actual condition

**Servicing:** Measures to preserve the specified condition.

**Repair:** Measures to restore the specified condition.



**WARNING:** When carrying out all maintenance work, the regulations in the country of installation must be strictly complied with.



**WARNING:** Maintenance work may only be performed in a careful manner by trained personnel familiar with the characteristics of the individual switchgear, in accordance with all relevant IEC safety regulations and those of other technical authorities, and with other overriding instructions. It is recommended that Medelec service personnel be called in to perform the servicing and repair work detailed below.



**CAUTION:** The inspection and servicing intervals for some of the equipment/components (e.g. parts subjects to wear) are determined by fixed criteria, such as switching frequency, length of service and number of sort-circuit breaking operations. On the other hand, for other parts the length of the intervals may depend, for example, on the different modes of operation in individual cases, the degree of loading, and also environmental influences (including pollution and aggressive air).

The operating and instruction manual for Vacuum circuit breaker, type VD4, must also be followed.

## 9.1 Intervals for inspection, servicing and repairs

Time intervals for maintenance work to be carried out always depend on the operating conditions of the switchgear, and mainly on the mode of operation, the number of rated and short-circuit current switching operations, ambient temperature, pollution etc. We recommend carrying out the maintenance work at the following intervals:

Activity	According to Section	Time interval in years	According to number of switching operations
Inspection	9.2	4 <sup>(1)</sup>	
Servicing	9.3	4 <sup>(2)</sup>	10000 <sup>(3)</sup>
Repair	9.4	As required	As required

<sup>1)</sup> In more demanding service conditions, we recommend reducing this interval suitably – also see section 1.3

<sup>2)</sup> According to the results of the inspection.

<sup>3)</sup> See the instruction manuals of the circuit breakers.

## 9.2 Inspection



**WARNING:** The working area must be isolated and secured against reconnection in accordance with the Safety Regulations specified by IEC and appropriate national standards before inspection.



**CAUTION:** Under normal operating conditions, inspection should be carried out according to the above schedule by specially trained professional electricians.



**NOTE:** Under abnormal operating conditions (including adverse climatic conditions) and/or special environmental stresses (heavy pollution and aggressive atmosphere, among others), inspection may be necessary at shorter intervals.

During these inspections, the condition of the switchgear should be monitored by carrying out:

- Visual inspection of the main switchgear components for grime, corrosion and moisture.
- Visual inspection for the effects of high temperature on the main circuits.
- Visual inspection for traces of partial discharge on the insulating material parts;
- Visual inspection of the surfaces of the contact systems, both primary and secondary for signs of corrosion.

Inspection must also include correct mechanical/electrical operation of the following parts:

Switching devices, actuating, interlocking, protection and signalling devices.

### **9.3 Servicing**

When, during an inspection as per paragraph 9.2, the need to carry out cleaning operations is noted, proceed as follows:



**WARNING:** The work area must be disconnected and locked against reconnection in conformity with the safety standards specified in the IEC directive and in the relative national regulations;

Clean the surfaces by:

- Removing any dry dust deposits, which are not very adherent, using a soft dry cloth or using a low alkaline detergent or with ETHANOL F 25 M in the case of more adhering dirt.
- Clean the insulating surfaces and the conductive components with ETHANOL F 25 M.
- After cleaning, rinse with clean water and dry carefully.
- Should any partial discharges occur as a consequence of the condensation phenomenon, a temporary remedy which is often effective is application of a thin layer of silicone over the surface involved. For a permanent remedy to this type of unusual problem, contact Medelec Switchgear Ltd.



### 9.3.1 Maintenance in busbar compartment



**WARNING:** Make the plant you want to work on safe (follow the plant safety regulations).

- Remove the circuit breaker from the panel where you want to work or lock in the isolated/test position and close the earthing switch.
- Close the earthing switch relative to the main busbar section.
- After removal of the unit upper rear cover and the busbar compartment cover, the main busbars are visible.
- Check busbars for signs of corrosion and discolouration due to high temperature.
- Using a torque wrench spanner, check tightness of all the screws fixing the main busbars. Refer to the table on section 6.2.1 for the tightening values.
- Visually check that the upper insulation monoblock where the tulip isolating contact is housed are integral and do not show any deterioration or signs of partial discharge.
- Clean the insulating materials before replacing the removed covers.

### 9.3.2 Maintenance in cable compartment



**WARNING:** Before opening the cable compartment door, make sure that the incoming feed is OFF and that the earthing switch is closed.

- Make sure that the circuit breaker is in the open position.
- Rack the circuit breaker out from the service position to the isolated/test position.
- Manually close the earthing switch and lock in the closed position.
- Remove the unit lower rear cover or open the cable compartment front door in the case of a wall mounted switchboard.
- Check busbars and cable connections for signs of corrosion and discolouration due to high temperature.

#### 9.3.2.1 Checking tightening of the power cable connections

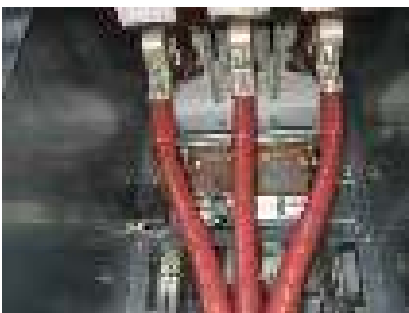

Internal view of the cable connection compartment.

Follow the procedure in Section 9.3.2. The cable connections are now visible.

- Using a torque wrench spanner, check tightness of all the screws. Refer to the table on section 6.2.1 for the tightening values.
- Visually check that the bottom monoblock where the tulip isolating contact is housed are integral and do not show any breakages or signs of partial discharge.
- Visually check that the insulating covering of the cable connections is integral and does not show any breakages.
- Clean all the insulating materials before closing the cable compartment cover.

#### 9.3.2.2 Earthing switch – type ST-E



Follow the procedure in Section 9.3.2. The earthing switch and mechanism are now visible.

- Manually carry out 5 closing/opening operations of the earthing switch.
- Carry out a visual inspection of the mechanical connections and check for any presence of dirt, humidity and signs of corrosion on the main operating shaft and on the contact parts of the blades.
- Remove any deposits of dust using a dry cloth that does not leave any deposits on the treated surfaces (do not use woolen cloths).
- If necessary, grease the moving mechanical parts by applying a thin layer of mechanical grease for moving parts.
- Close the cable compartment cover.

### 9.3.2.3 Cleaning and checking of current transformers

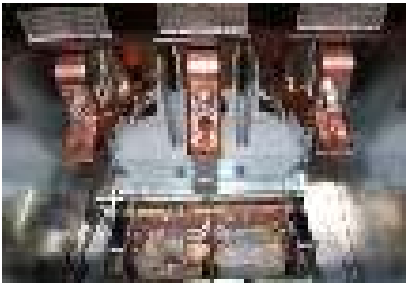

Follow the procedure in Section 9.3.2. The current transformers are now visible just above the rear cover.

- Visually check the connections of the current transformers.
- Using a torque wrench spanner, check the tightness of all the screws. Refer to the table on section 6.2.1 for the tightening values.
- Clean all the insulating materials before closing the cable compartment cover.

### 9.3.2.4 Cleaning, checking and replacement of the fixed voltage transformers



Follow the procedure in Section 9.3.2. The fixed Voltage transformers are now visible in the lower front chamber for feeder units or the rear of the cable compartment for riser and measurement units.

- Visually check the voltage transformer connections.
- Using a torque wrench spanner, check the tightness of all the screws. Refer to the table on section 6.2.1 for the tightening values.
- Carry out a visual inspection of the transformers and check for any presence of dirt or signs of partial discharge.
- Remove any deposits of dust using a dry cloth that does not leave any deposits on the treated surfaces (do not use woollen cloths).



Should it be necessary to replace the fixed voltage transformers, remove the secondary wiring and the primary connection. Unscrew the four bolts holding the VT to the supporting structure, and remove from the unit using the tool rack base plate shown in the photo to slide the voltage transformer out of the panel.

### 9.3.2.5 Cleaning and checking of the withdrawable Voltage Transformer



The withdrawable VT's are accessible either by opening the lower compartment door for feeder units or the circuit breaker compartment door for riser and measurement panels.

- Rack the withdrawable unit out from the service position to the isolated/test position.
- Open the voltage compartment door.
- Manually remove the voltage transformer from the unit onto the trolley following procedure in section 7.11.1.1.
- Carry out a visual inspection of the transformers and check for any presence of dirt, humidity and signs of corrosion on the moving parts.
- Carry out a visual inspection on the isolating and contact system and check for any traces of partial discharge on the insulating material parts.
- Carry out a visual inspection on the fuses and check for any presence of dirt.
- Remove any deposits of dust using a dry cloth that does not leave any deposits.
- Insert the unit into the applicable panel and close the compartment door.

### 9.3.2.6 Fused voltage transformer – Fuse replacement



**WARNING:** Before replacing the fuse make sure the VT is not energized!

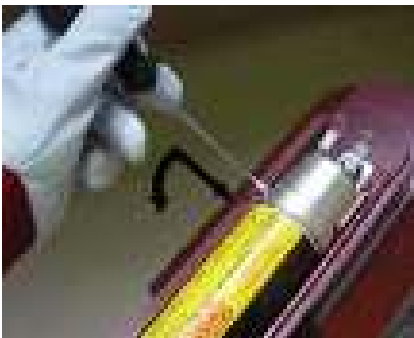
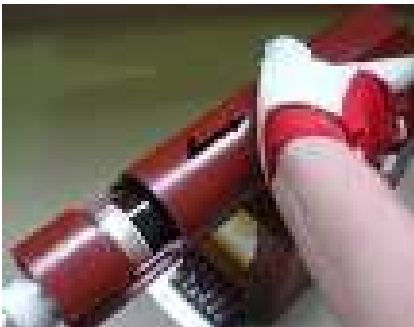

- Make sure the VT is safe to work on,
- To replace the fuse, slightly press down upper cover and move it to the back.
- Use a thin screw-driver to elevate the fuse from the point of fuse contact and remove the fuse.
- Replace with a new fuse inside the holder.
- Make sure that the fuse is positioned firmly.
- Replace the upper cover.

### 9.3.3 Maintenance in circuit breaker compartment

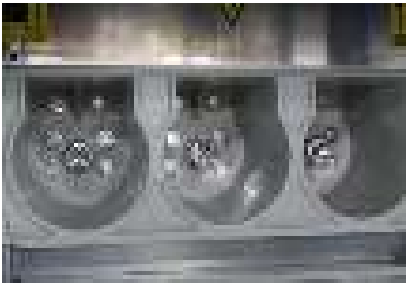

**WARNING:** Before opening the circuit breaker compartment door for inspection of the compartment, make sure that the unit is completely de-energised and that the earthing switch is closed.

- Make sure that the circuit breaker is in the open position.
- Rack the circuit breaker out from the service position to the isolated/test position.
- Remove the circuit breaker from the unit.
- De-energise the busbars.
- Manually close the earthing switch.
- Carry out a visual inspection on the top and bottom isolating contacts in the circuit breaker compartment and check for any presence of dirt, humidity and signs of corrosion on the moving parts.
- Remove any deposits of dust using a dry cloth that does not leave any deposits on the treated surfaces (do not use woolen cloths).
- Inspect the mechanical moving parts for signs of damage or wear and if necessary, grease the moving parts by applying a thin layer of mechanical grease.

#### 9.3.3.1 Checking functionality of the interlocks

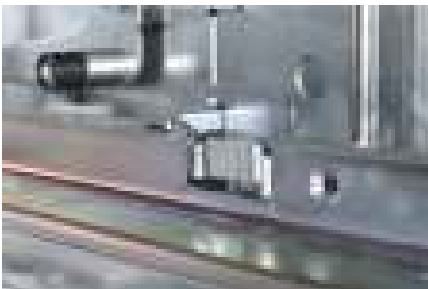

- Carry out a visual inspection of the mechanical parts of the interlocks, key locks, door interlocks, and check for any presence of humidity and signs of corrosion on the moving parts.
- Remove any deposits of dust using a dry cloth that does not leave any deposits on the treated surfaces (do not use woolen cloths).
- Check that the moving parts can slide freely. If necessary, grease the mechanical moving parts by applying a thin layer of mechanical grease for moving parts.
- Refer to the interlocks section 4.



### 9.3.4 Checking correct operation of the protection relay

- Make the plant you want to work on safe (follow the plant safety regulations).
- Make sure that the circuit breaker is in the open position.
- Rack the circuit breaker out from the service position to the isolated/test position.
- Manually close the earthing switch.
- Carry out secondary injections to check perfect operation of the protection relays.



**NOTE:** To check operation of the protection relay, refer to the manufacturing operating manual of the protection relay provided.

### 9.3.5 Cleaning and checking the auxiliary connections

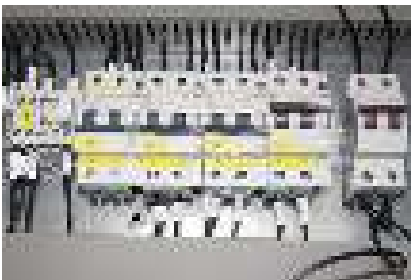

- Make the plant you want to work on safe (follow the plant safety regulations).
- Make sure that the circuit breaker is in the open position.
- Rack the circuit breaker out from the service position to the isolated/test position.
- Manually close the earthing switch.
- Open the miniature circuit breakers positioned inside the low voltage compartment to switch off the auxiliary power supply to the panel.
- Carry out a visual inspection on all the cabling, terminal boxes and check for any presence of dirt.
- Manually check correct tightness of the terminal blocks.



## 9.4 Repairs

### 9.4.1 Switchgear in general

Repair of surface damage:

- Carry out repair work immediately after a defect has been discovered.
- Carefully remove any white rust from passivated operating parts and rust formation on phosphatised parts with a wire brush or metal-free cleaning pad, e.g. Scotch-Brite, and clean with a dry cloth. Then grease evenly (with mechanical grease for moving parts).

Apparatus in general:

- Follow the maintenance instructions in the manuals for individual equipment components.
- Check that the bolt connections at the contact points in the busbar system and the earth connections are tight, and that the contact system functions correctly.
- Where necessary, grease slide plates and bearings in the panel again or thoroughly clean them. Then grease them again with mechanical grease for moving parts.
- Re-apply grease on contact areas in the contact system when corroded or otherwise as necessary, or, when lubrication is inadequate or missing, thoroughly clean the areas concerned and grease them again with mechanical grease suitable for moving parts.

## 9.5 Testing interlock conditions

Test individual interlocks following the table in Section 4.1. Each condition has to be tested individually for correct functionality.

## 9.6 Spare parts, auxiliary materials and lubricants

### 9.6.1 Spare parts

A spare parts list is available on request for procurement of spare parts. It basically includes moving parts and parts subject to wear. When parts are required, the serial number of the relative switchgear or switching device should always be quoted.

---

## 9.6.2 Accessories, Auxiliary materials and lubricants

Refer to list of accessories and tools listed in section 7.1

### Lubricant

- Vaseline as oxidation protection for busbars.
- Mechanical grease for moving parts.

### Halogen-free cleansers

- ETHANOL F 25 M (for general cleaning).

### Touch-up paint

- Standard colour RAL 7035.











**HEAD OFFICE & FACTORY**

BLB033, Bulebel Industrial Estate, Zejtun ZTN 3000  
P.O. Box 20, Paola PLA 1001, Malta.  
T. (+356) 21693750 - F. (+356) 21693754 - E. info@medelec.com.mt

**TRIPOLI OFFICE**

Madaris El Funun W Assanaqa  
Building 82, Flat 9, 24th December Street, P.O. Box 82118, Tripoli, Libya.  
T. & F. (+218) 21 4444050

**[www.medelec-switchgear.com](http://www.medelec-switchgear.com)**