

**OPERATION & MAINTENANCE MANUAL  
AIR INSULATED SWITCHGEAR -  
TYPE VHIH upto 12kV**



# CONTENTS

CI No	Sub CI No	Description	Page No
A		<b>INTRODUCTION</b> .....	01
1.0		<b>CUBICLE SPECIFICATIONS</b> .....	02
2.0		<b>PRECAUTIONS TO BE TAKEN CARE</b> .....	05
	2.1	Safety Aspects .....	05
	2.2	Unloading & Transportation .....	05
	2.3	Unpacking & Inspection .....	05
	2.4	Handling of Functional Units .....	06
	2.5	Storage Conditions .....	07
3.0		<b>PANEL OVERVIEW</b> .....	09
	3.1	Panel Structure .....	09
	3.2	VCB Construction .....	12
4.0		<b>INSTALLATION</b> .....	15
	4.1	Foundation Preparation .....	15
	4.2	Order of Installation .....	16
	4.3	Horizontal movement of Panels .....	16
	4.4	Erection of Cubicle .....	17
	4.5	Connection of Main Busbar .....	18
	4.6	Connection of Earth Busbar .....	19
	4.7	Connection of Control Wires .....	20
	4.8	Power cable termination .....	21
	4.8.1	Preparation of Cable Gland Plate .....	21
	4.8.2	Power cable termination .....	21
	4.9	Inspection after Installation .....	22
5.0		<b>OPERATING INSTRUCTIONS</b> .....	23
	5.1	Operating Instructions for VCB .....	23
	5.2	Earthing Operations .....	27
	5.3	PT Operation Sequence .....	30
	5.4	Safety Shutters .....	30
	5.5	Control Plug Arrangement .....	31
	5.6	Anti Condensation Heater .....	31
	5.7	VCB Racking Shutter Arrangement .....	32
	5.8	Interlocks .....	32
	5.8.1	General Interlocks Provided .....	32
	5.8.2	Padlocking Facility .....	32
	5.8.3	Visual Indications .....	33

# CONTENTS

CI No	Sub CI No	Description	Page No
6.0		TESTING AND COMMISSIONING .....	34
	6.1	Physical Inspection .....	34
	6.2	Alignment check .....	34
	6.3	Dielectric test .....	34
	6.3.1	Insulation test .....	34
	6.3.2	One minute power frequency test .....	35
	6.4	Relay injection test .....	35
	6.5	Operation test .....	35
	6.6	Final Check before energization .....	35
7.0		MAINTENANCE .....	36
	7.1	GENERAL .....	36
	7.2	Daily Inspection .....	36
	7.2.1	Visual Inspection .....	36
	7.2.2	Variants .....	37
	7.2.3	Check on metal parts .....	37
	7.2.4	Noise Identification .....	37
	7.3	Annual Maintenance .....	37
	7.4	Safety Precautions .....	37
	7.5	Maintenance Procedures .....	37
	7.6	VCB Maintenance & Inspection .....	39
	7.6.1	Maintenance & Inspection Schedule .....	39
	7.6.2	Check on Vacuum .....	41
8.0		TROUBLESHOOTING .....	43
9.0		DO'S AND DON'TS .....	45
10		MANDATORY SPARES .....	46
		NOTES .....	47

# A - INTRODUCTION

## IMPORTANT NOTE -

Only the Specific written Technical Instructions supplied by L&T must be used. Our products must only be commissioned, operated, serviced, repaired or decommissioned in accounts with Technical Instructions which have been supplied by the

manufacturer. Non Compliance with this instruction may result in serious damage to the product and its associated items, as well as health hazard or mortal danger.

## WARRANTY

Our products are subjected to factory inspection and testing according to the applicable standards and provisions.

The correct function and the service life of the switchgear are influenced greatly by compliance with the installation, commissioning and operating conditions stipulated in this manual.

Non-compliance with these provisions may compromise warranty claims.

Any local provision which does not contradict the specifications of this document, especially as regards safety for personnel and buildings, must be complied with.

L&T cannot be held liable for the possible consequences of:

- Non-compliance with the provisions contained in this manual,

which refer to international regulations.

- Non-compliance with the instructions of the suppliers of cables and connecting accessories as regards application and installation.
- Any aggressive climate conditions (humidity, pollution etc.) prevailing in the immediate environment of switchgear not suitable to this effect or not protected accordingly.

This manual does not contain any instructions regarding the mechanical lock-outs to be performed. The work described is performed on de-energized (on installation) or mechanically locked – out (decommissioned) switchgear.

# 1.0 CUBICLE SPECIFICATIONS

12 kV AIS with VCB

Panel Details	Standards	IEC 62271-200			
	Type Designation	VHIH			
Voltage ratings	Voltage	up to 12 kV			
	Power Frequency Withstand Voltage	75 / 95* kVrms			
	Impulse Withstand Voltage	28 / 38* kVp			
	Frequency	50 / 60 Hz			
Current ratings	Rated Current	630 / 800 A	1250 A	2000 A	3150 / 4000 <sup>^</sup> A
	Short Time Withstand Current (3s)	25 / 26.3 kA			
		40 / 50 kA			
	Short Circuit Making current	62.5 / 65.75 kAp			
100 / 125 kAp					
Dimension	Width#	600 mm	800 mm	1000 mm	
	Depth #	1570 / 1970 / 2170 / 2270 mm			
	Height	2495 mm			
Construction	Partition Class	PM			
	Loss of Service continuity	LSC-2B			
	Degree of protection	IP4X (Higher IP on request)			
	Internal Arc Classification	A (F, L,R), up to 40 / 50kA, up to 1s			
VCB	IEC Standard	IEC 62271-100			
	Type Designation	VK series			
	Operating Sequence	O-0.3sec-CO-3min-CO			
	Opening time	< 35 ms			
	Break time	< 3 cycles			
	Mechanical Operations	10,000			
	Closing /Tripping Coil	24 / 48 / 110 / 220 V DC			
	Spring charging motor	24 / 48 / 110 / 220 V DC   110 / 240 V AC			
Auxiliary Contacts	6NO+6NC / 12NO+12NC*				

\* offered on request    <sup>^</sup> with forced ventilation    # 50kA Panel width & depth starts from 800mm & 1970mm respectively

# SPECIFICATIONS

## 7.2 kV AIS with VCU

Panel Details	Standards	IEC 62271-200			
	Type Designation	VH1H			
Voltage ratings	Voltage	up to 7.2 kV*			
	Power Frequency Withstand Voltage	20 kVrms			
	Impulse Withstand Voltage	60 kVp			
	Frequency	50 / 60 Hz			
Current ratings	Rated Current	200 - 400 A			
	Short Time Withstand Current	up to 8 kA			
	Short Time Withstand Current (with Fuse)	25 / 40 / 50 kA			
Dimension	Width#	600 mm			
	Depth#	1570 / 1970 mm			
	Height#	2495 mm			
Construction	Partition Class	PM			
	Loss of Service continuity	LSC-2B			
	Degree of protection	IP4X (Higher IP on request)			
	Damage Classification	Type C			
	Internal Arc Classification	A (F, L,R), 40kA, up to 1s			
VCU	IEC Standard	IEC 62271-106			
	VCU Type	Non Latched		Latched	
	Type Designation	VCU7N200	VCU7N400	VCU7L200	VCU7L400
	Opening time	< 35 ms			
	Mechanical Endurance	up to 3 Million		up to 0.3 Million	
	Electrical Endurance	up to 0.3 Million (AC-3)			
	Rated Duties (40% on Load Factor)	Class 300			
	Closing /Tripping Coil	110 / 220 V DC			
	Auxiliary Contacts	3NO+3NC			

# 2 Tier Panel width & depth starts from 800mm & 1970mm respectively

\* 12 kV VCU offered on request

# 1.1 NORMAL SERVICE CONDITIONS

## 1.1.1 - Standards and operating conditions:

Applicable standard: IEC 62271-200, IEC 62271-100, IEC 62271-102.

## 1.1.2 - Normal service conditions for indoor - Admissible ambient temperature

The ambient temperature must be in the range of – 5°C to +40°C.

For Higher ambient, please contact L&T Sales Department.

## 1.1.3 - Installation altitude

High-voltage switchgear has been designed according to the appropriate international standards and can be installed up to an altitude of 1000m.

At higher installation altitudes, the reduced voltage endurance must be taken into account.

In special cases, please contact the L&T Sales Department.

## 1.1.4 - Air pollution

The ambient air must be free of dust, smoke, corrosive or combustible gases, steam and salts.

## 1.1.5 - Admissible air humidity

- The average air humidity measured over a period of 24 hours, must not exceed 95%.
- The average vapour pressure, measured over a period of 24 hours, must not exceed 22 mbar.
- The average air humidity measured over a period of one month, must not exceed 90%.

The average vapour pressure, measured over a period of one month, must not exceed 18 mbar. Condensate may form in case of sudden temperature fluctuations due to excessive ventilation, increased air humidity or hot air. Such condensate formation can be avoided by a suitable arrangement of the room or the building (suitable ventilation, air dehumidifier, heating etc.).

If the average air humidity exceeds 95%, we recommend that appropriate remedies are adopted. Support or any advice, please contact the L&T Service.

# 2.0 PRECAUTIONS TO BE TAKEN CARE

## 2.1 - Safety Aspects

- The Switchgear panels are designed for Indoor Application with all required safety features.
- Before carrying out any installation, operation and maintenance, the service person should be fully acquainted with the relevant safety regulations covering this equipment as well as inside of the substation.
- Check that the personnel operating the apparatus have this instruction manual with them.
- We recommend that installation and commissioning should be carried out by qualified and authorized personnel.
- Ensure compliance of local (site) legal and safety norms.

## 2.2 - Unloading & Transportation

- The switchgear panels are dispatched in appropriate packaging for the prevailing conditions, e.g. seaworthy packaging.



- Unloading of Panels shall be done as per Instruction stickers given on Panels.
- Panel shall be unloaded with sufficient capacity of crane or Hydra. If unloading is done with wire ropes, fit lifting ropes of appropriate load capacity with shackles and ensure that lifting hooks are locked properly.
- Transport switchgear panels upright only. Carry out loading operations only when it has been ensured that all precautionary measures to protect personnel and materials have been taken and using a
  - Crane,
  - Fork-lift truck and/or
  - Manual trolley jack

- Never tilt the crates over as shown below. Non Compliance with this stipulation may damage the equipment. Always keep it upright.

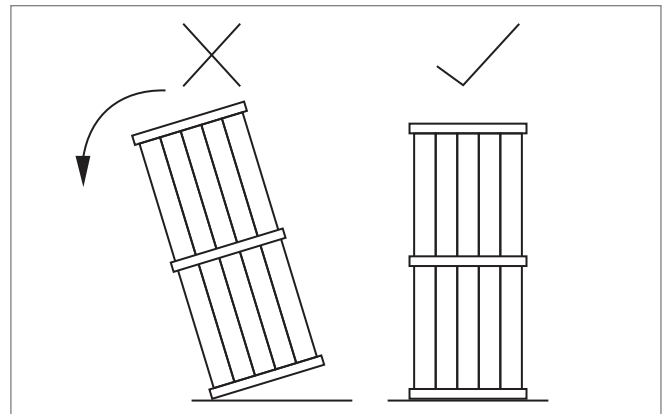

Figure 2.2 –Crate Positioning

## 2.3 - Unpacking & Inspection

- Generally, each switchboard is supplied along with complete Packing List in which major items are as follows :
  - VCB
  - Panels
  - VCB spring charging handle
  - VCB racking handle
  - Earth Switch Operating Handle
  - Emergency Trip Rod
  - Main bus bars
  - Allen Key
  - Loose Castle keys
  - VT Trolley
- Upon arrival at site, the consignment shall be unpacked within one (1) week and checked against the packing list or the delivery note.
- While unpacking wooden cases, top must be removed first.
- It is advisable to locate the switchgear at the sub-station before unpacking. (THE EQUIPMENT SHOULD BE EXAMINED IMMEDIATELY AFTER THE RECEIPT.)
- In case of shortage in supply or damage to the items, report the same within two (2) weeks, accompanied with a full description/ photographs of the missing/damaged parts. Any delay in making the claims will not be entertained.

2.4 - Handling of Functional Units

- Packaging for air and sea transport: using two slings supporting 1000kg each and lifting device.
- Minimum height given on the below diagram shall be respected.

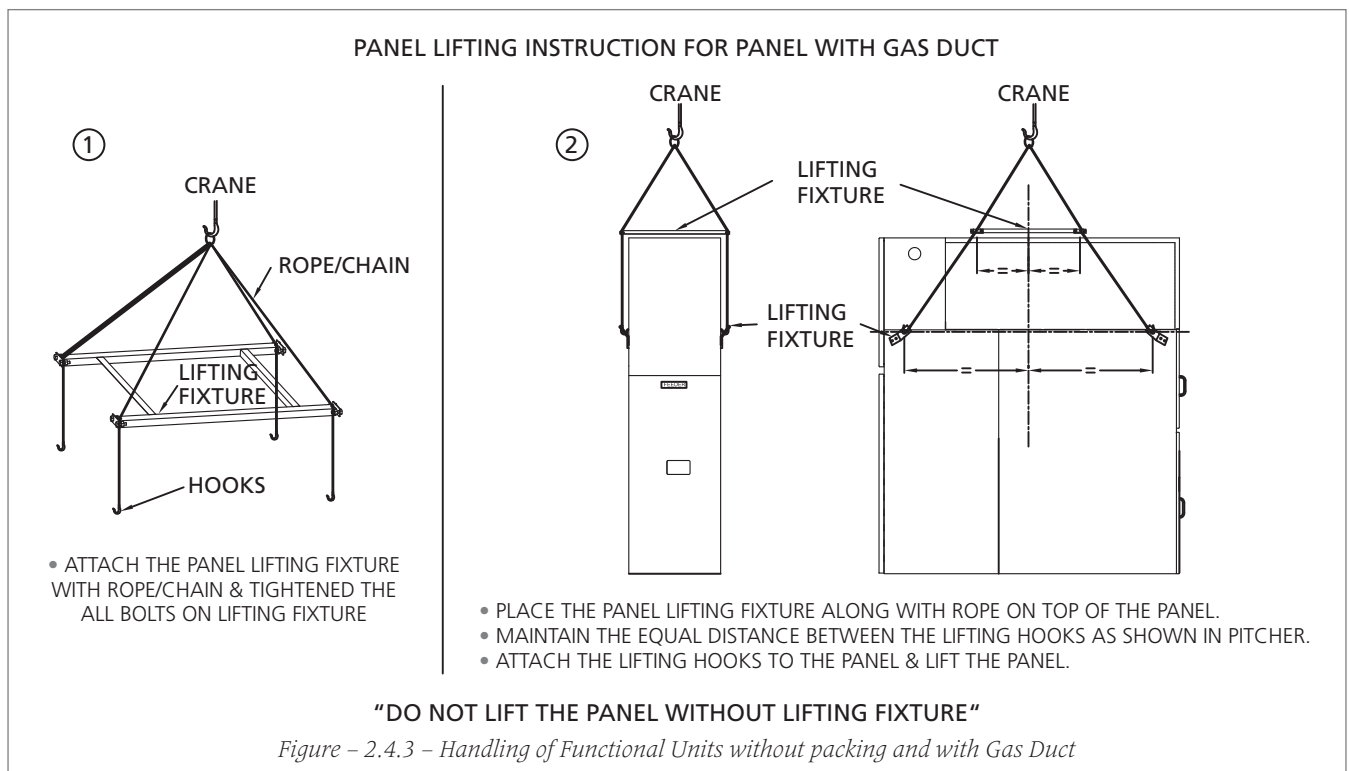
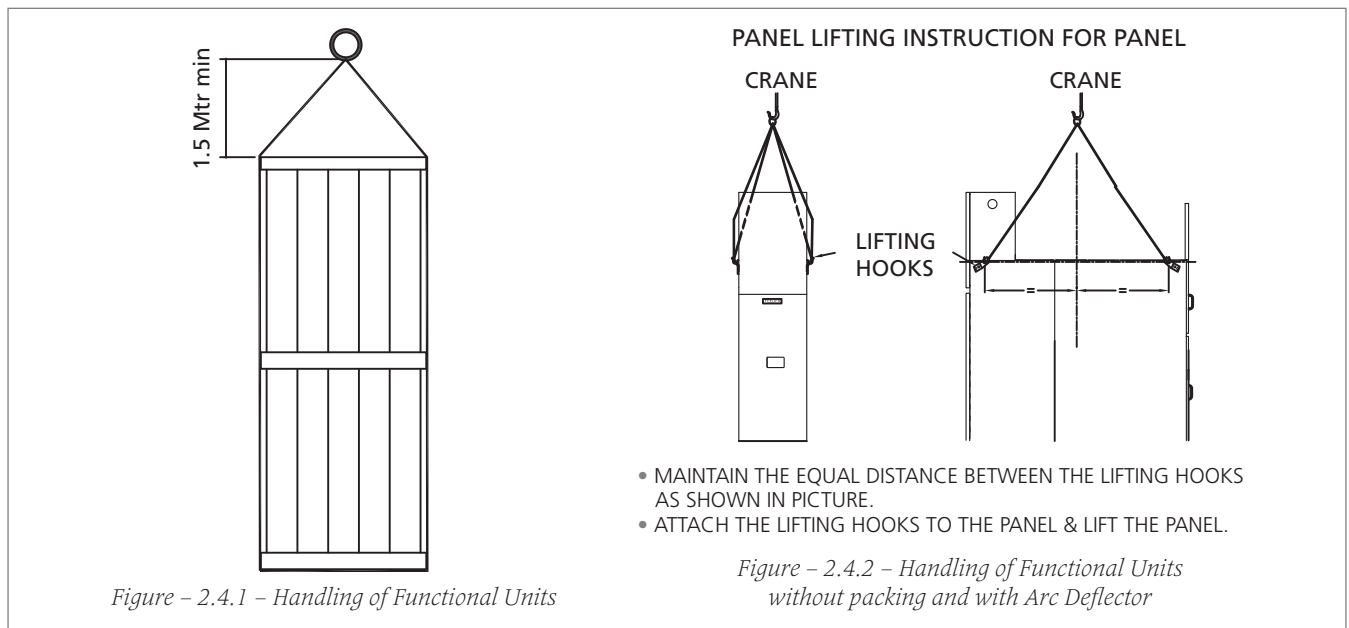

# PRECAUTIONS

## 2.5 - Storage Conditions

- The switchgear should be stored in a clean, dry and well-ventilated environment.
- The storage area must shelter the equipment from deterioration by agents like.
  - Water
  - Water Vapour
  - Salt Laden air
  - Pollution of any type
  - Micro-organisms
- Store switchgear panels standing upright.
- Do not stack switchgear panels.
- Switchgear panels are not weather-proof and should not be left outdoor where rain and moisture may cause irreparable damages.
- For temporary storage for less than two (2) weeks, cover the switchgear with plastic sheets to protect it against ingress of dust.
- Do not walk on the roof of the panels (rupture points in pressure relief devices).

## 2.6 - Intervention Levels

Definition	Level		
Operations carried out by the client	1		
Operations requiring training and which can be performed by an approved third party		2	
Work which can only be carried out by L&T			3

## 2.7 - Special Instructions for storage period between 0 to 6 months

Wrapped under plastic Film	1	2	3
Packaging should be periodically inspected	X	X	X
When the equipment is unpacked	-	X	X
10-12 times manoeuvres should be carried out in order to check the mechanical operation of the equipment	-	X	X
The minimum threshold (85% of Un) of the coil for electrical operation should be tested	-	X	X

## PRECAUTIONS

### 2.8 - Special Instructions for storage period between 6 to 12 months period

Wrapped under heat sealing cloth with desiccant bags	1	2	3
Packaging should be periodically inspected (absence of any perforation amongst others)	X	X	X
When the equipment is unpacked : - slightly dilute the dry greases with neutral paraffin oil	-	X	X
10-12 times manoeuvres should be carried out in order to check the mechanical operation of the equipment	-	X	X
The minimum threshold (85% of Un) of the coil for electrical operation should be tested	-	X	X

### 2.9 - Special Instructions for storage period between 12 to 24 months

Wrapped under heat sealing cloth with inspection doors to change the desiccant bags	1	2	3
Packaging should be periodically inspected (absence of any perforation amongst others)	X	X	X
The desiccant bags should be regularly changed	X	X	X
When the equipment is unpacked : - light maintenance operations should be performed	-	-	X
The minimum threshold (85% of Un) of the coil for electrical operation should be tested	-	-	X

# 3.0 PANEL OVERVIEW

## 3.1 - Panel Structure

Type VHIH switchgear is totally metal-clad and compartmentalized. The switchgear is completely assembled, wired-up and tested in the factory before delivery.

The VHIH panel is fabricated from high grade pickled-and-oiled steel sheets, which are chemically treated before painting to provide adequate protection against corrosion and weathering.

The Panel consists of four mutually separated compartments

- Circuit breaker compartment
- Busbar compartment
- Cable & CT compartment
- Low voltage compartment

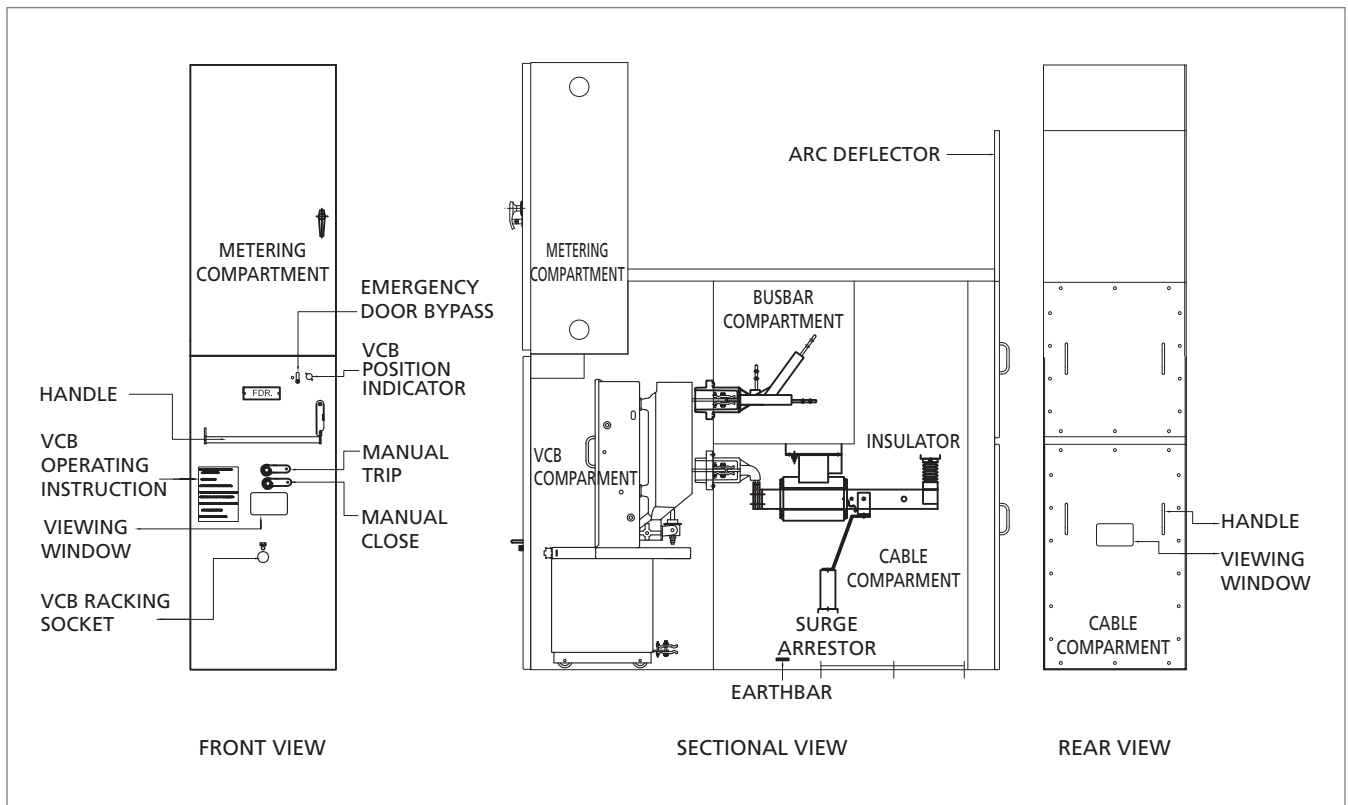

Figure – 3.1.1 Typical Panel General Arrangement

### 3.1.1 - Circuit breaker Compartment

The Circuit breaker compartment contains a withdrawable vacuum circuit breaker.

The withdrawable VCB moves on two in-built rails. It can be transferred between the Connected and Test positions using a Racking Handle with front door closed.

In the Connected /service position, the moving upper and the lower contact arms of the VCB engages with the fixed contacts connected to the bus bars and the outgoing circuit respectively.

Shutters operated by the VCB movement In the Test/

Disconnected positions, separates the contact arms and their fixed contacts. These shutters prevent access to the fixed contacts, while in isolated position.

### 3.1.2 - Busbar Compartment

The Busbar compartment holds the busbar for connectivity between the switchgear and epoxy coated connection (Busbar Bushing) that is connected to breaker. The busbar extends from one switchgear cubicle to the adjacent and so on. All the busbar joints are covered with PVC Boots.

**3.1.3 - Cable and CT compartment**

The Cable compartment contains:

- Insulating bushings with Cable connecting terminals.
- A section of the main earth busbar.
- Current transformers.

The Gland Plate is fitted at rear bottom of cable compartment. The cable is accessible from rear of the cubicle by opening the cable compartment covers.

**3.1.4 - Low Voltage Compartment**

This compartment consists of all the low voltage equipments viz. Fuses MCBs, control terminals, protective relays, Indicating

lamps/meters, push buttons, relays and control switches etc are mounted on LV compartment door and inside LV Compartment.

**3.1.5 - VT Compartment ( 2-Tier VT Panel)**

A 2-Tier arrangement for the Bus VT Trolley and the Line VT trolley in the same panel is as shown above.

Both the VT trolley can be Racked-in and Racked-out individually.

Exclusive Panel for Bus VT can also be provided with same arrangement excluding Line VT trolley and its fixed contacts.

Line VT can also be mounted below breaker and even in Riser Panel as per customer requirement.

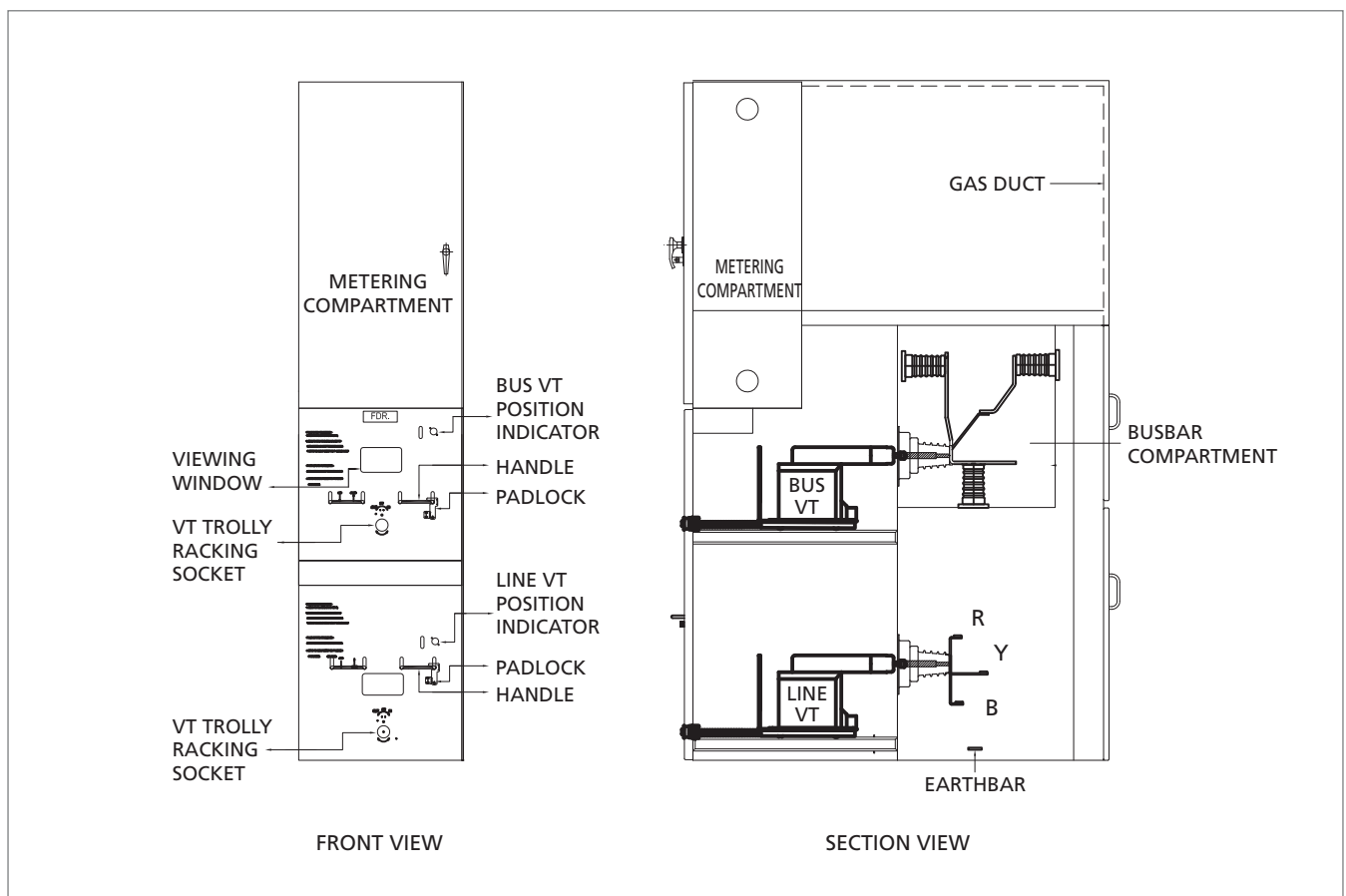

Figure : 3.1.5 Typical Bus VT & Line VT Arrangement in 2-Tier VT Panel

3.1.6 - Arc Deflector / Gas Duct

As Shown in Figure 3.1.7 Arc Deflector is used for internal arc fault of 0.1Sec and as shown in figure 3.1.5 Gas Duct is used for internal arc fault of 1Sec. It will ensure that ionised gases are safely evacuated.

3.1.7 – Vacuum Contactor

Vacuum Contactor is generally given in single Tier arrangements as shown in Figure 3.1.7. Even double Tier Arrangement is given as per customer Requirement.

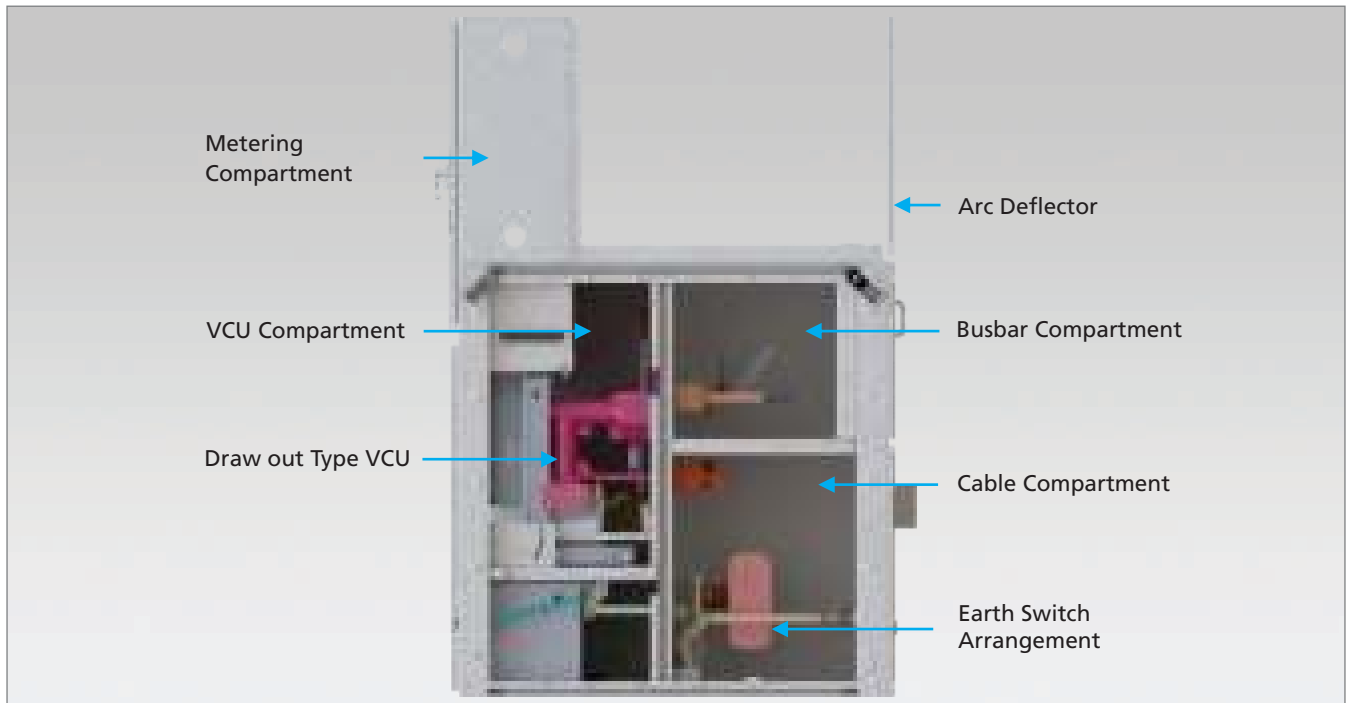

3.1.7 VCU panel

3.1.8 - Typical panel Arrangement

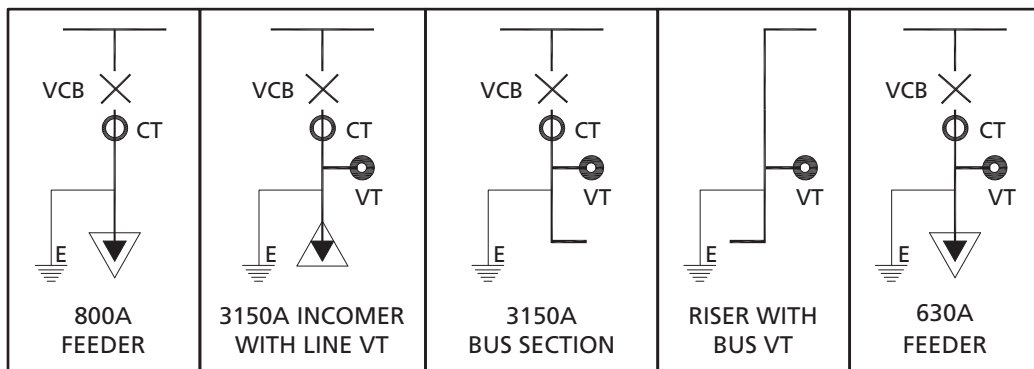

Figure 3.1.8 Typical Panel Arrangement

Typical single line diagrams such as incomer, buscoupler & Outgoing feeder is shown. For buscoupler, riser panel is given separately.

3.2 - VCB

3.2.1 - Construction

Vacuum circuit breaker consists of a moulded insulator, housing three (3) vacuum interrupters and an operating mechanism that uses the spring stored energy system. VCB mechanism is mounted on a fixed trolley. During Racking operation VCB rolls over the floor trolley by means of racking wheels. VCB front facia consists of openings for indicators and operating mechanism.

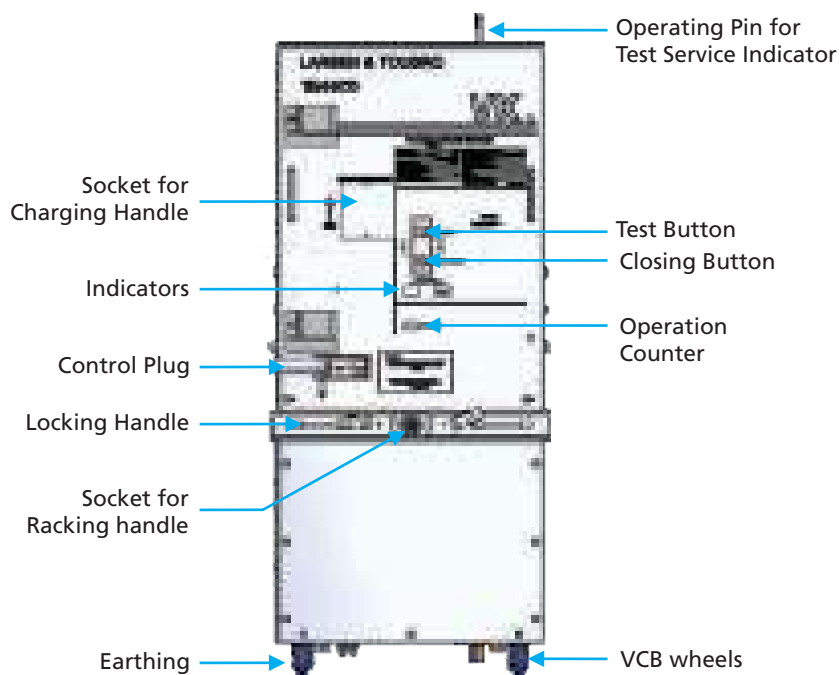

Figure 3.2.1-A - 800A VCB - FRONT VIEW

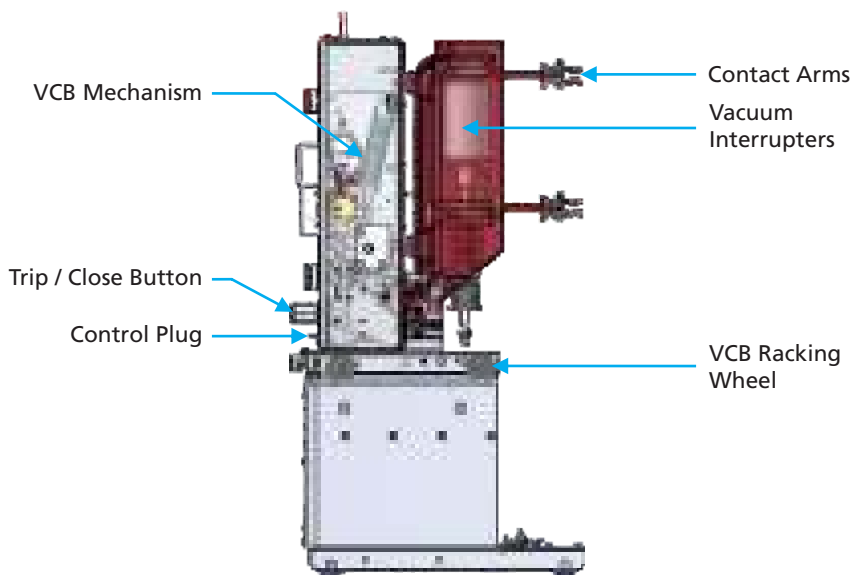

Figure 3.2.1-B - 800A VCB - SIDE VIEW

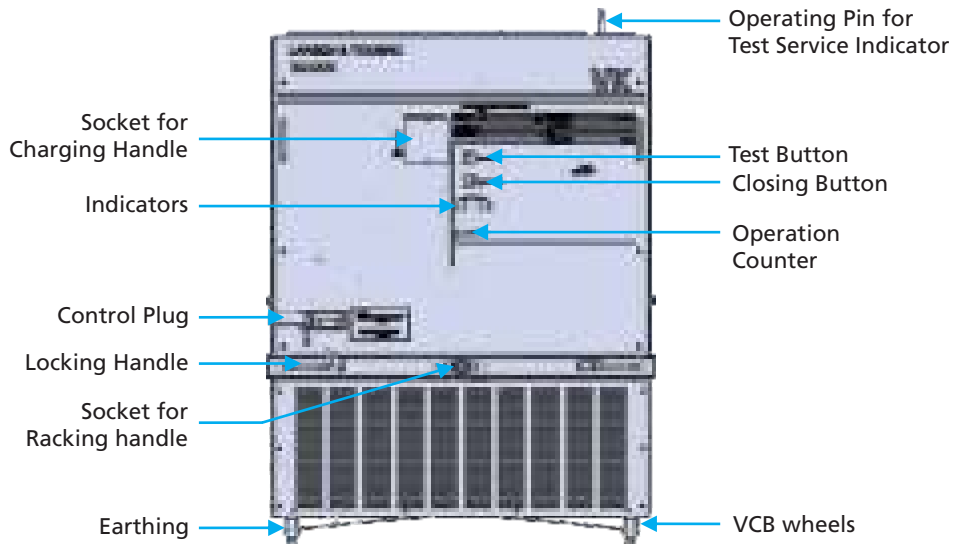

Figure 3.2.1-A - 1000A VCB - FRONT VIEW

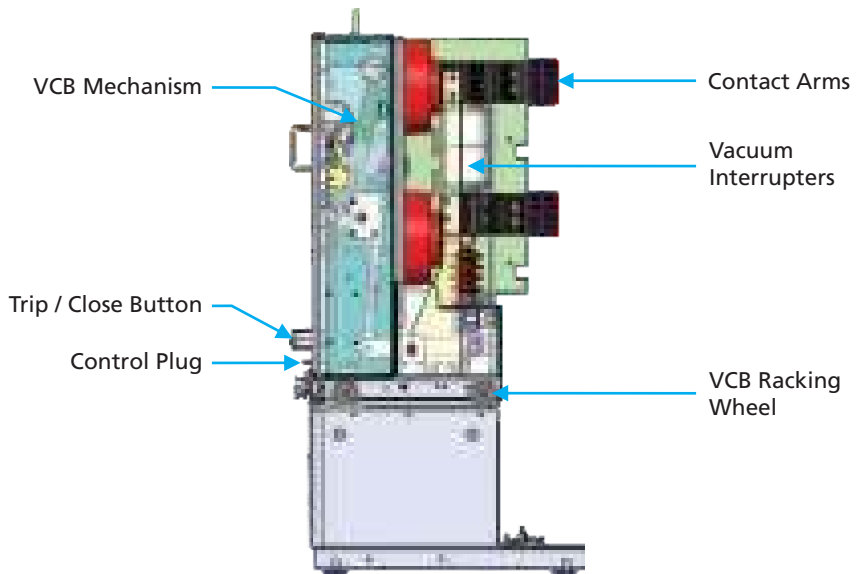

Figure 3.2.1-B - 1000A VCB - SIDE VIEW

### 3.2.2 - VCB Manual Operation

#### a) Charging Operation

**NOTE:** Manual operation can be performed while breaker is at test position and VCB door opened or during VCB outside the panel.

Confirm that the VCB is in the "DISCHARGED" state.

The CHARGED condition indicated by YELLOW colour. While DISCHARGED condition indicated by WHITE colour.

Manual charging can be performed in the event of motor malfunctions.

Note: The number of times the handle must be operated depends on the angle of handle during operations.

Insert the charging handle into the charging socket and move it up and down several times (usually 7 counts) until a 'click' sound is heard.

If the VCB is in OPENED conditioned, it is ready to be CLOSED.

#### b) Closing Operation

Push the CLOSE button to initiate the close operation. The indicators on the VCB will now read CLOSED and DISCHARGED.

#### c) Tripping Operation

Push the TRIP button to initiate the opening operation. The indicator will now read OPEN.

### 3.2.3 - VCB Electrical Operation

#### a) Charging Operation

When a control supply of the VCB is connected, the motor starts running, and the indicator changes to CHARGED status after the closing springs are charged. The motor will then stop. The charging operation is now complete.

#### b) Closing Operation

When a closing signal is given, the closing coil is energized, the indicator changes to CLOSE, confirming that the VCB is close. As soon as the closing is complete, the motor starts to run, and the closing spring is recharged.

#### c) Tripping Operation

When a tripping signal is given, the tripping coil is energized, the indicator changes to OPEN confirming that the VCB is open.

# 4.0 INSTALLATION

## 4.1 - Foundation Preparation

It is important that the finished floor area is flat, and not sloping. If the floor is not level, the switchgear may be deformed during installation, resulting in eventual malfunction of the equipment. Pay particular attention to the following requirements for correct erection:

- The panel must be placed on a flat and level foundation without any foreign materials over the openings. Foundation channels or uni-struts may be used to ensure this condition. However, ensure that the space in between is cement filled. The level of the floor should be within +/- 0.5mm/m and +/- 2mm across the entire width of the switchboard.

- Mark the allocated positions of the panels on the cement surface for easy positioning. Ensure that minimum working space is available on Front, rear, Top and on side of first and last panel once the panels are coupled.
- The area of the sub-station floor in front of the switchgears must be flat and level so that the VCB can be easily racked in and out of the panel. Special cement with "hardener" should be used in these areas to prevent the cement from cracking under the weight of the VCB.

**Note** - CARE SHOULD BE TAKEN WHEN TIGHTENING THE FOUNDATION BOLTS AS EXCESSIVE TIGHTENING WILL DISTORT THE BOTTOM PLATE.

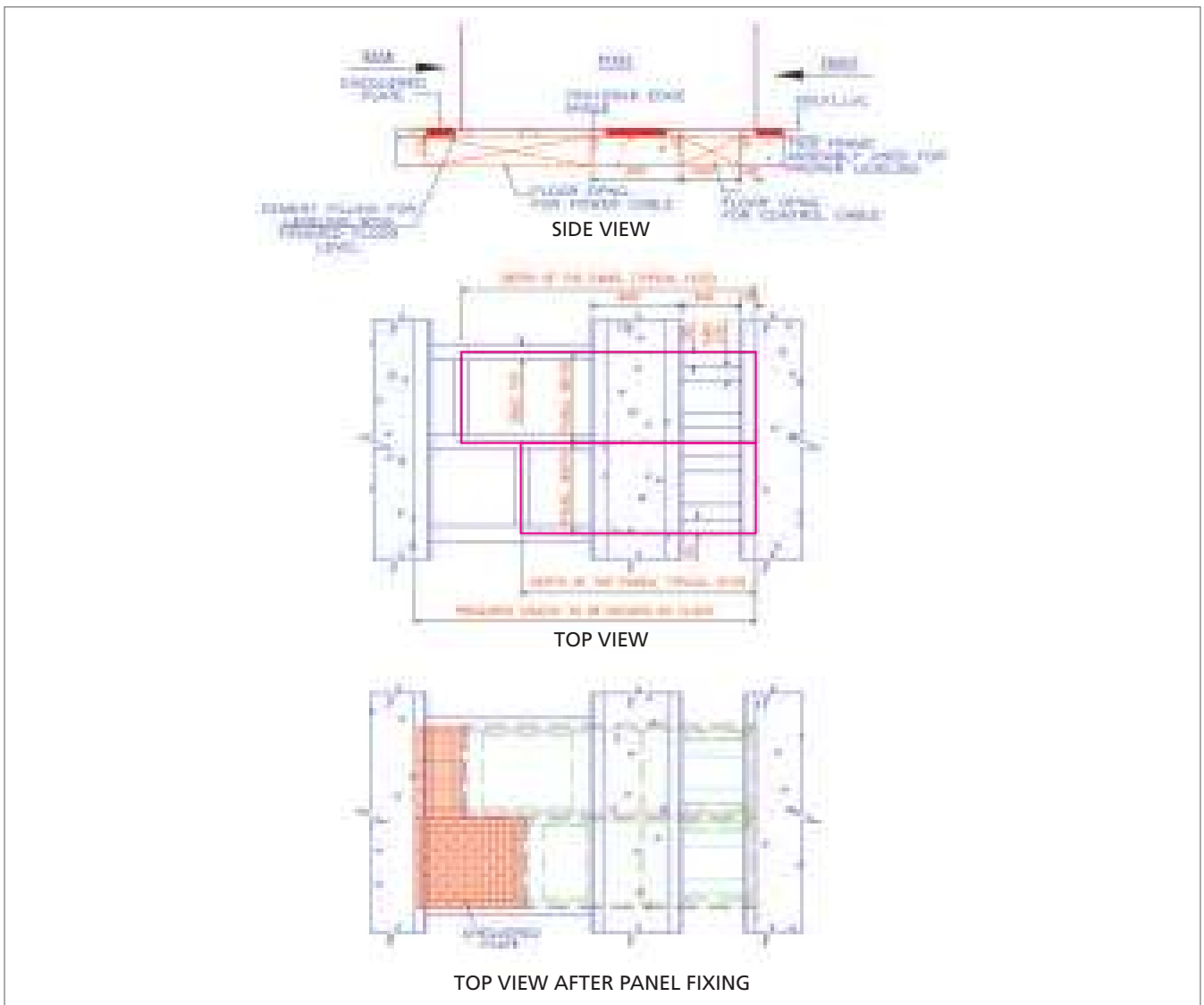

Figure 4.1 – Typical Foundation Plan

## 4.2 - Order of Installation

- 1) Draw cubicle reference line on the foundation frame. These reference lines will serve a guide for more accurate alignment of the cubicle.
- 2) Remove the transportation bolt from top of the cubicle. Ensure the Earth switch (If applicable) is in Closed position to open the rear cover.
- 3) Withdraw the VCB from the housing during the positioning of the panel to reduce weight.
- 4) Start installing the cubicle from the centre and moving outwards, toward the left and right. After the cubicle is moved to the desired centre position.
- 5) Locate the cubicle onto the centre position with the aid of a hydraulic jack, making sure that its front base channel is aligned to the reference line. If the alignment is good, the foundation bolts can be quite easily inserted into the framework holes.
- 6) Rack the VCB into the panel and check the panel's vertical alignment at its front, rear and side.
- 7) Position the second panel next to the centre panel. The sides of the panel must be vertical. This can be achieved by ensuring that the panel is compactly coupled. Line up the front and side, ensuring no interpanel gap.
- 8) Rack the VCB into the panel and check panel's alignment as per the first panel.
- 9) Couple the panels together by bolting the adjacent side frames. Also couple the Arc Deflector / Gas Duct (as applicable).
- 10) Fix the foundation bolts at the base plates of the panels.
- 11) Seal the interpanel gaps at the busbar compartment with silicon glue to prevent ingress of dust.
- 12) Remove top covers from the busbar compartments for busbar installation and refix the same after busbar installation.
- 13) Connect the copper links of the earth busbars.
- 14) Make connection of control wiring.
- 15) Clean complete panel from inside & outside.
- 16) Do Inspection after installation for complete board.
- 17) Now panel is ready for termination of Power cables & control cables.

## 4.3 - Horizontal movement of the Panel

Check that the doors are locked so that they will not open while being moved. For ease of shifting, the VCB should be removed from the panel. Use steel pipes for rolling and crow bars for positioning the panel to the desired locations. All the pipes must be of the same diameter and longer than the panel's width. A minimum of four rollers is required for transporting the panel.

Remove the rollers after use.

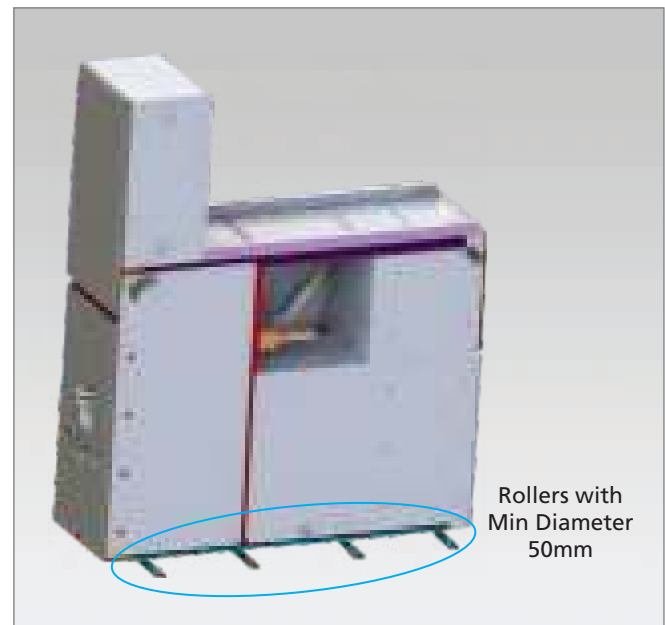

Figure 4.3 – Horizontal Movement of Panels

Apply the crowbar to the corners of the panel, not along the edges of the side frames or to the door. If possible, do not apply bar directly onto the panel; use a protective plate between plate and frame. Do not use excessive force or drop the panel by quick withdrawal of the bar. Gently slide the bar out. Alternatively, if site conditions allow, you may also use forklift, lifting truck or pallet trolley for the movement of panels.

4.4 - Erection of Cubicle

Units or sections should be erected and coupled in the following manner:

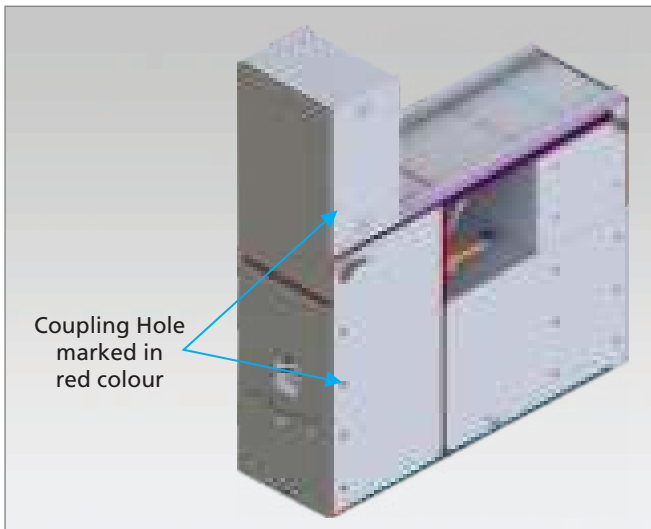

Figure 4.4.1 – Panel showing Coupling Hole Location

- After Placing One panel to other, Panel shall be coupled on the holes as shown in figure 4.4.2.
- Generally M8 Bolts are required for Panel coupling.
- Similarly all the panels shall be coupled together.

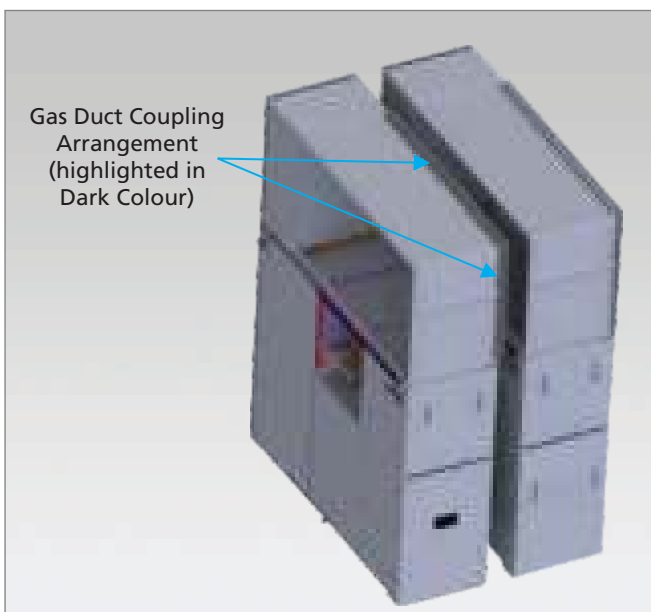

Figure – 4.4.2 A – Panel duct Coupling

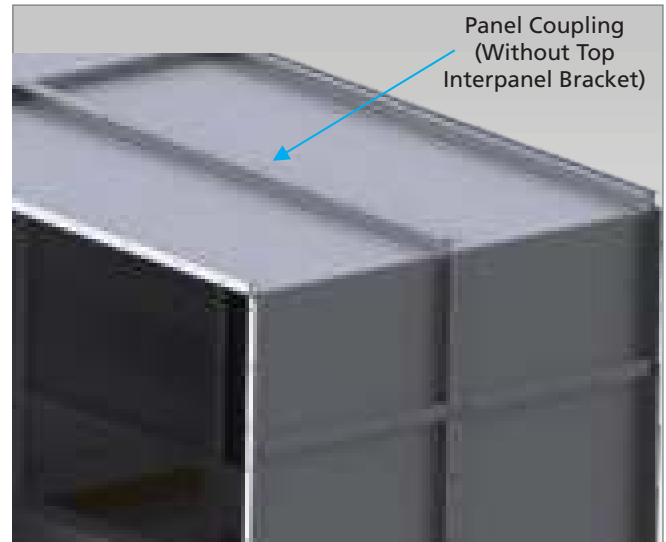

Figure 4.4.2 B – Panel Coupling without Top Interpanel Bracket

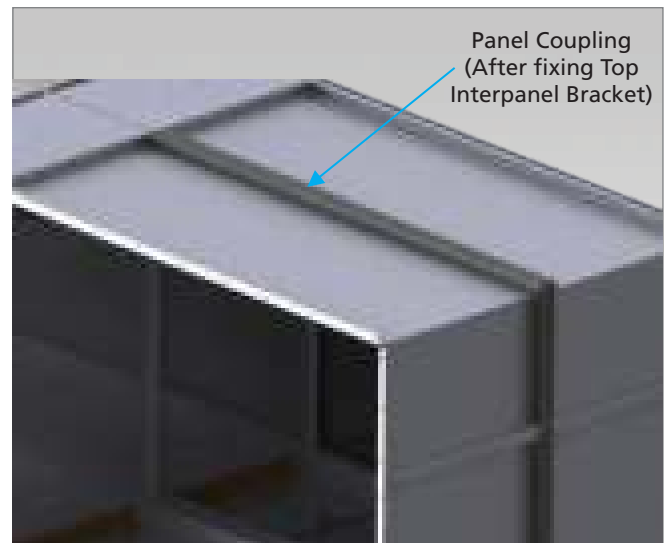

Figure 4.4.2 C – Duct coupling after fixing Top Interpanel Bracket

- After Panel Coupling Arc deflector Coupling / Gas Duct Coupling shall be done.
- In Gas Duct Coupling First remove the Top Interpanel Bracket.
- Couple the two panels gas duct with Nut Bolts (from Top & rear side). Refer Figure 4.4.2 B.
- Now Fix the Top Interpanel bracket (as highlighted in Dark grey Color) on coupling as shown in figure 4.4.2 C.

4.5 - 1 - Connection of Main Busbars

- The main busbars arrangement is as shown in Below Figure's. All Busbar are connected to Primary Disconnecting switch(PDS). The arrangement is to be strictly followed otherwise the busbar joints will be unevenly stressed.
- Ensure that busbar mating surfaces are clean and apply a thin film of contact grease for bare bar connections only. Then, install the interpanel bus bars using the correct size of bolts and nuts.

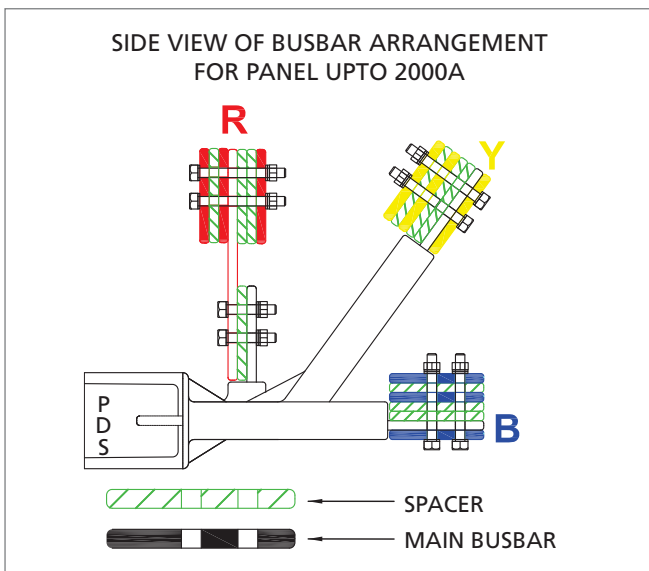

Figure 4.5.1 A – Busbar Side View Arrangement upto 2000A

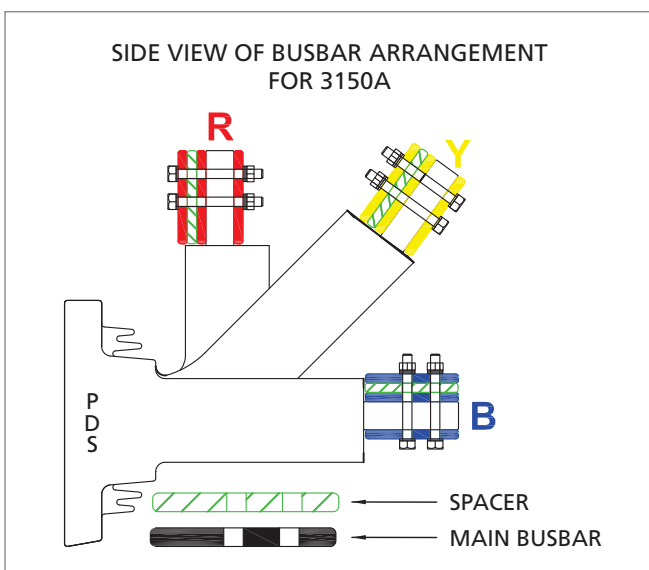

Figure 4.5.1 B – Busbar Side View Arrangement upto 3150A

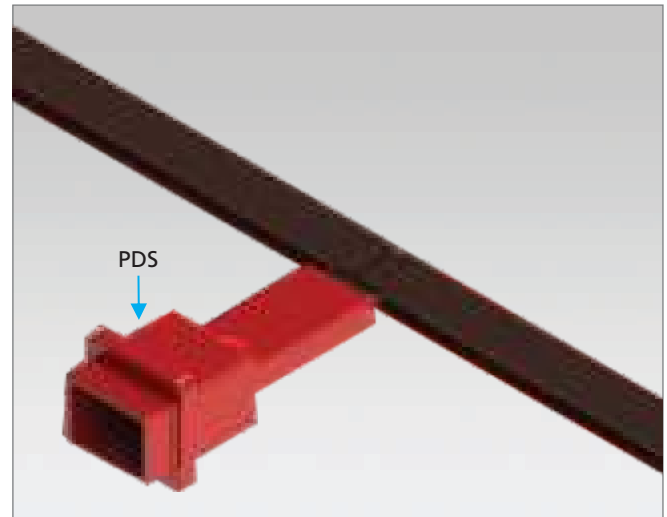

Figure 4.5.2 A – Main Busbar Arrangement Intermediate Panel

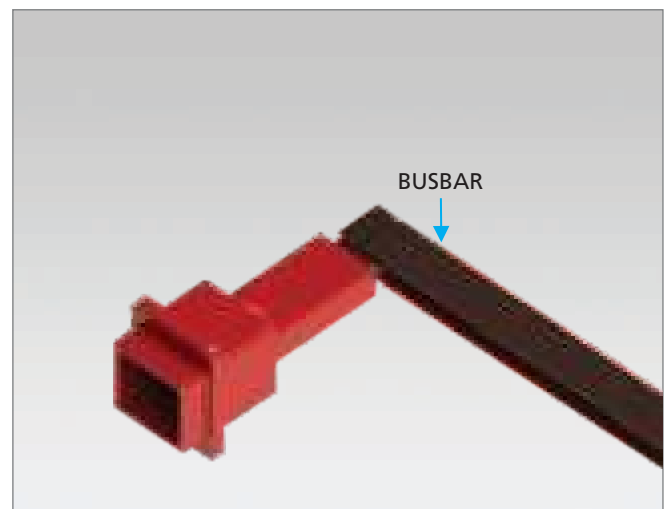

Figure 4.5.2 B – Main Busbar Arrangement End Panel

**CAUTION :** Do no stand on busbar bushing or the bottom partition plate of the busbar compartment.

- Connection of Main Busbar's shall be done as shown in figure – 4.5.2 A.
- Connection of End Busbar's shall be done as shown in figure – 4.5.2 B.
- Clean all busbar and busbar joints before bolting the same.
- Bolting at Busbar joints shall be done as shown in figure – 4.5.2 C.
- Tighten the bolts with a torque wrench as per below given table. Mark tightened bolts with a marker pen.

Sr. No.	Bolt Size (mm)	Torque Wrench (NM)
1	10	47

Table 4.5.3 Bolt size v/s Required Torque wrench for Busbar

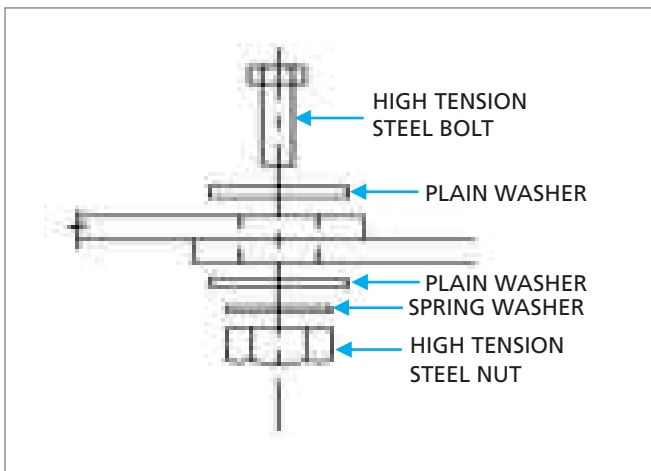

Figur - 4.5.2 C Bolting of Copper Connections

4.5.3 - Typical Insulation Boot (Optional)

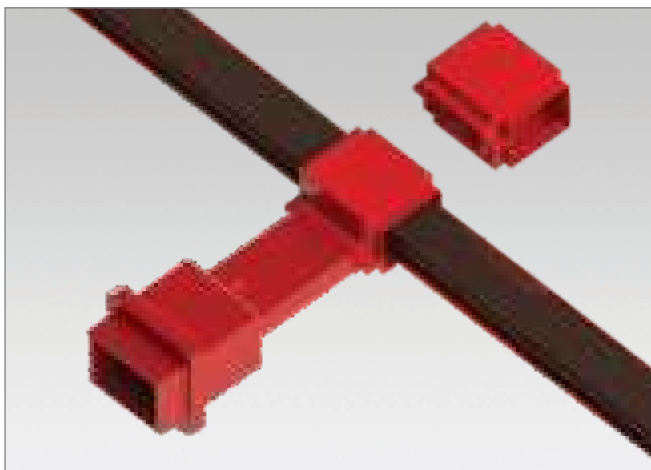

Figure – 4.5.3 A Insulating Boots on Main Busbar Intermediate Panel

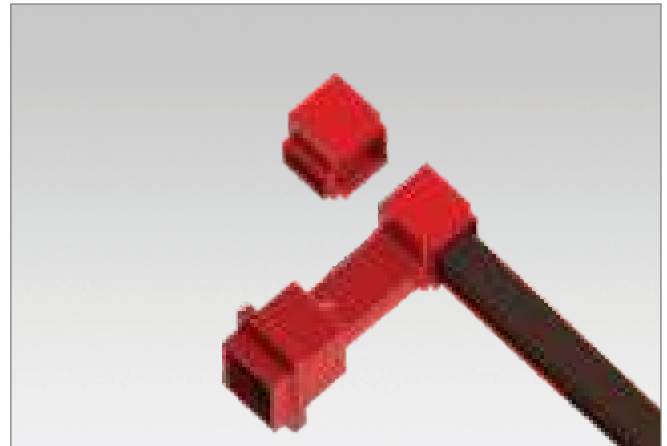

Figure – 4.5.3 B Insulating Boots on Main Busbar End

- Intermediate Busbar boots shall be connected as shown in figure 4.5.3 A.
- End Panel boots shall be connected as shown in figure 4.5.3 B.
- Sealed “end boots” should be used for busbars at both ends of the switchboard i.e. red and blue phase for the far left and right panels respectively, as viewed from the front of the panel.
- Secure the boots with the boot pins provided. All boot pins must be properly fastened to ensure that the boot will not drop off.
- For non-standard design, HV insulation tape must insulate any other exposed live parts that are not covered with the insulation boots.
- Ensure that all joint surfaces are clean and securely bolted before wrapping with the sealant.

4.6 - Connection of Earth Busbar

Earthing busbar links, supplied together with the panel are to be fixed onto the external earth bar along the middle of the panels as shown in below Figure's.

Ensure that all the joints between the earth bar sections are clean and securely bolted as per below table.

Sr. No.	Bolt Size (mm)	Torque Wrench (NM)
1	8	25

Table 4.6 A - Table 4.5.3 Bolt size v/s Required Torque wrench for Earth Bar

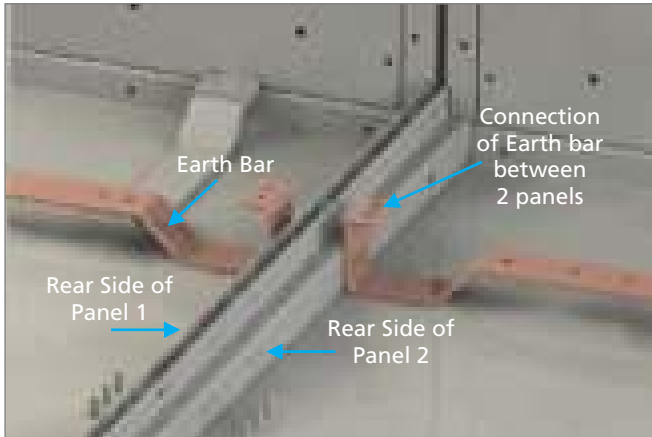

Figure 4.6 B Earth Bar View before Connection

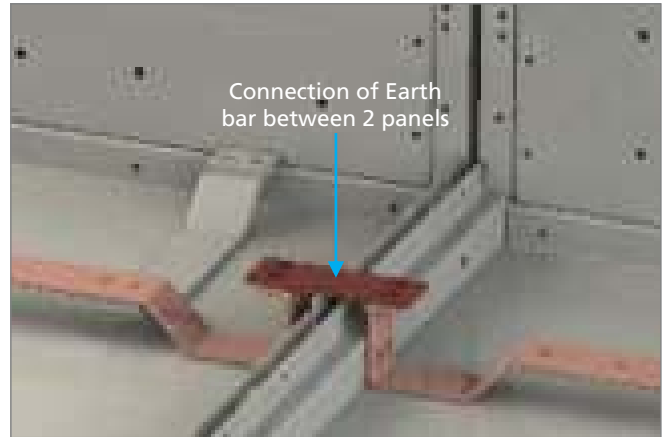

Figure 4.6 C Earth Bar View after Connection

As shown in Figure 4.6 B, Panels have been coupled and earth bar connection is to be done. After Coupling Earth bar links shall be passed from one panel to another through earth bar coupling hole. As shown in Figure 4.6 C, Panels have been coupled and earth bar connection is done. The connection to the station earthing system should have a cross section of not less than that of the earth bar mounted on the switchboard.

#### 4.7 - Connection of Control Wirings

Terminals for the connection of auxiliary control supplies and other external wirings are provided in the metering compartment.

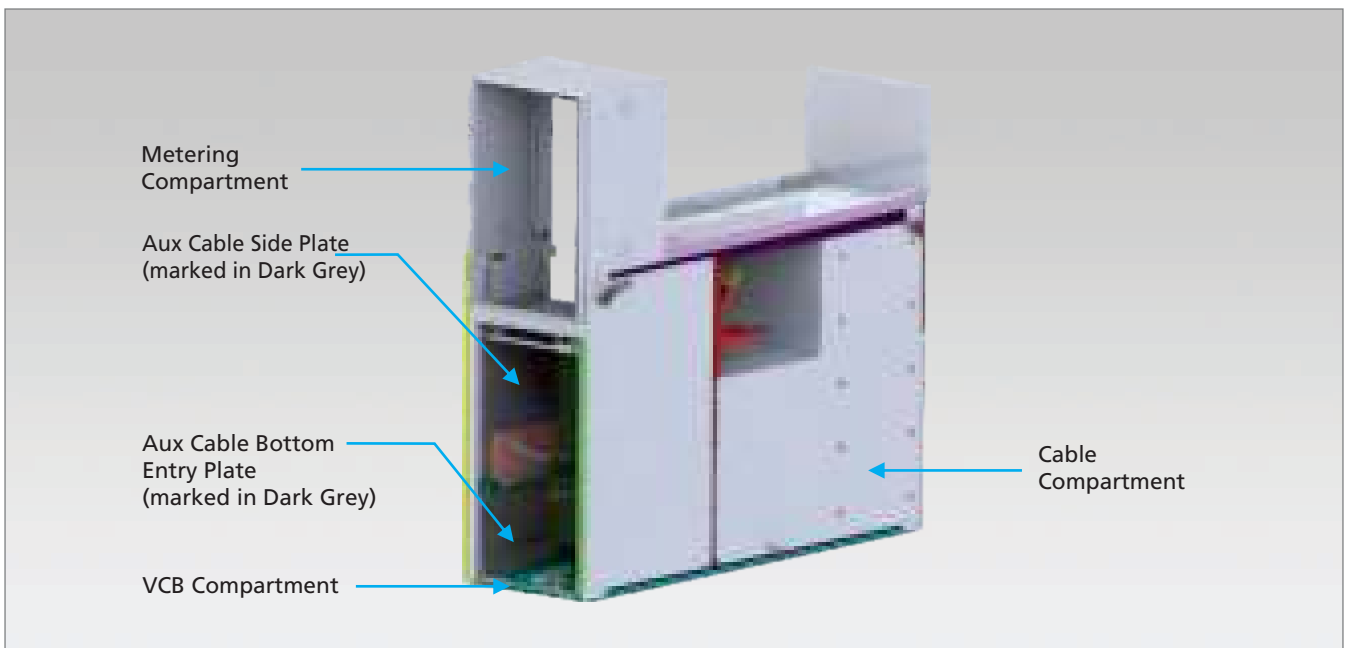

Figure 4.7 - Control Wiring Arrangement

For control wiring connection, remove the Aux Cable side plate and Aux Cable Bottom entry plate (Figure 4.7). Control cable entry is given at front and rear bottom side of the panel. After Control cable connection, refix the Aux Cable side plate & bottom plate.

## 4.8 - Power Cable Termination

The power cable entry point is provided with a removable gland plate and is located at the base of the cable compartments. Standard cable entry is from the bottom. Top entry is available if specified at the time of placing the order.

### 4.8.1 - Preparation of Cable Gland Plate

The gland plate is provided to facilitate cable entry. The procedure for fixing the gland plate is as follows.

Note: Connect only one end of the cable earth, not both.

- Measure the diameter of the cable.
- While cable termination cut a circle on the gland plate to match the cable diameter as shown in below Figure.

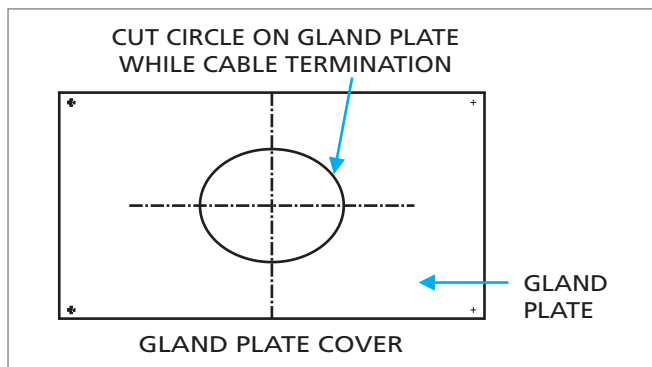

Figure - 4.8.1 A - Gland Plate Installation

- Adjust the position of the power cable and mount the cable gland plates onto the welded studs at the base plate. Tighten the nuts securely.
- If there is any gap between the power cable and the gland cover, apply sealing compound around the Cables to fill the gap as shown in Figure 4.8.1 B.

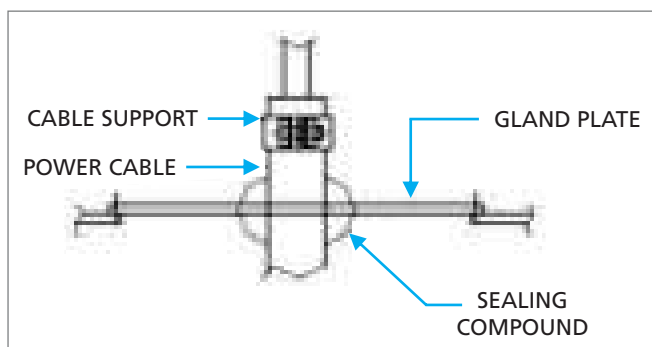

Figure 4.8.1 B - Assembly of Cable Gland Plate

- The cable earth screen should be properly connected to the panel earth.
- For Single core cables, there should be a gap between the split plates and the former sealed with the compound. This is to prevent eddy current circulation.

### 4.8.2 - Power Cable Termination

Figure 4.8.2 C the cables should be terminated vertically and exposed live parts at cable terminations are to be insulated with tape. Cable supports are provided to prevent undue stress on the bushing caused by the weight of an unsupported cable.

For top cable entry design, cable supports is an optional item. If not provided, ensure no undue stress at the cable connection by positioning the cable lug opening to the same level as the bar hole.

Refer to the instruction manuals supplied by the manufacturer of the termination kits for preparing the cable termination.

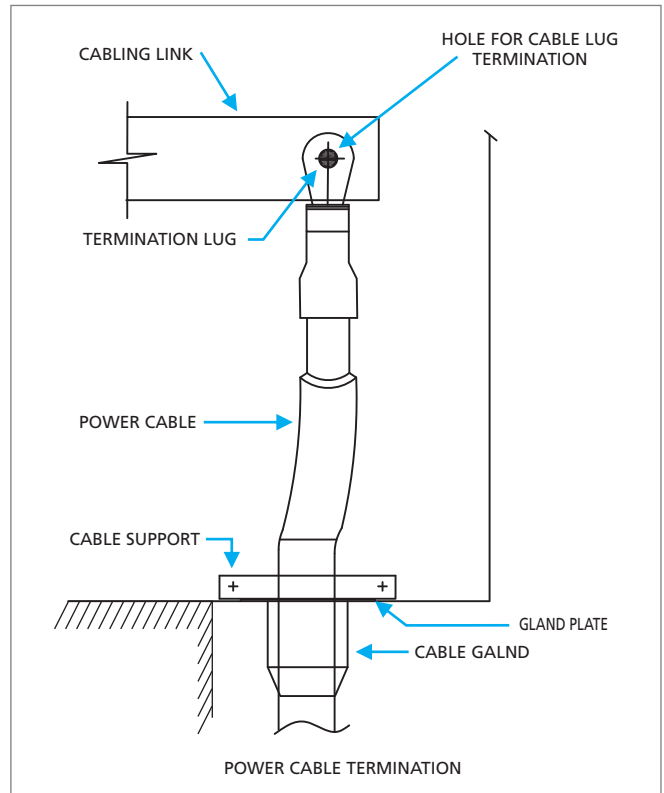

Figure 4.8.1 C - Assembly of Cable Gland Plate

Upon completion of cabling, plug the opening of the cable entry to prevent small animals from entering the switchgear.

## 4.9 - Inspection After Installation

- Check the door to ensure that it can be opened and closed smoothly.
- Check that all bolts and nuts are securely bolted.

**Note:** Bolts and nuts are marked by manufacturer to enable detection of loose connections.

If these markings are shifted, re-tighten nuts.

- Ensure that all interpanel gaps are sealed.
- Ensure that all exposed busbar connecting joints are fitted with insulation boots or taped properly.
- Ensure that no tools or loose parts are left inside any compartment.
- Clean any debris and dust inside and outside of the panels.

# 5.0 OPERATING INSTRUCTIONS

## 5.1 - Operating Instructions for VCB rack-in and Rack Out

### VCB Operation:

The breaker is of the horizontal withdrawal and horizontal isolation type of truck. It is designed with the interlocks against accidental and dangerous operations.

VCB Rack-IN or Rack-OUT operations to be carried out with VCB compartment door closed only.

It can be inserted in to *CONNECTED/SERVICE* position or withdrawn to *DISCONNECTED / TEST* position with the aid of a racking handle provided. Before starting VCB Operation please ensure that all Panel components are known.



Figure 5.1 A - VCB in Disconnected

Figure 5.1 B - VCB in Test

Figure 5.1 C - VCB in Service

- As shown in Figure 5.1 A VCB is in DISCONNECTED position.
- As shown in Figure 5.1 B VCB is in TEST Position. Indication shown on VCB door will be in Green Colour.
- As shown in Figure 5.1 C VCB is in Service Position. Indication shown on VCB door will be in Red Colour.

**Note** - For Detail view of Test Service Indicator & VCB Handle with latch please refer Figure No 5.5.

#### VCB Racking-In to TEST Position Operation Sequence.

- While racking-in VCB to test position, ensure the racking mechanism interlock handle in latched / locked position.
- Hold the Breaker handles & gently push the Breaker into panel.
- Unlatch the racking mechanism interlock handle to lock the Breaker with panel.
- Interlock plate goes into the slots provided at the side of the panel. These handle operate left to right in horizontal plane.
- Breaker is now in TEST Position.

## VCB Racking Out to Disconnected Position Operation Sequence.

- While racking out VCB to Disconnected position, Pull the Interlock Plates and latch the Handle.
- Hold the Breaker handles & gently pull the Breaker out of panel.
- Now the Breaker is in DISCONNECTED Position.

### 5.1.1 - VCB Door Operating Instructions are as follows



Figure 5.1.1 A - Door Locked

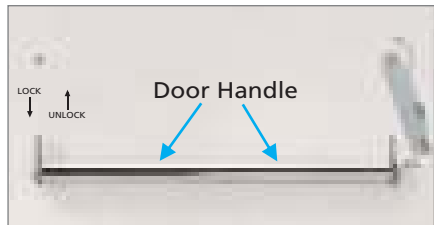

Figure 5.1.1 B - Door latch Open



Figure 5.1.1 C - Door Opening

#### A. Door Opening Sequence

- Before door opening ensure the VCB in in Open condition.
- Door is in closed position with padlocking arrangement as shown in Figure 5.1.1 A.
- For Door Opening Padlocked to be removed, latch to be opened (rotate anticlockwise) as shown in Figure 5.1.1 B.
- Door Handle shall be lifted upwards and door shall be opened as shown in Figure 5.1.1 C.

#### B. Door Closing Sequence

- Ensure the wheel bracket plates are at closed position.
- Lift the VCB Door handle (if necessary), hold it in same position and swing the door towards panel.
- Once the door flushing with the panel, push the VCB door handles downward and latch the handles (rotate clockwise).
- Padlock the latch.

### 5.1.2 - VCB Rack-In & Rack-Out Operation Sequence - Closed Door

#### **CIRCUIT BREAKER RACK-IN OPERATION SEQUENCE :-**

1. ENSURE THE FOLLOWING BEFORE RACK-IN;
  - a VCB IS IN 'TEST' POSITION.
  - b CONTROL PLUG IS PROPERLY CONNECTED TO VCB.
  - c VCB IS IN 'OPEN' CONDITION.
2. SWING THE DOOR FOR CLOSING AND LOCK IT BY MOVING HANDLE DOWN.
3. PAD LOCK DOOR HANDLE.
4. ROTATE THE KNOB OF 'SOCKET FOR VCB RACKING HANDLE' ANTICLOCKWISE AND INSERT THE VCB RACKING HANDLE.
5. ROTATE THE RACKING HANDLE CLOCKWISE UNTIL;
  - a VCB POSITION INDICATOR SHOWS 'SERVICE' AND
  - b MECHANICAL RESISTANCE IS FELT TO ROTATE THE HANDLE.
6. REMOVE THE RACKING HANDLE.
7. ROTATE THE KNOB OF 'SOCKET FOR VCB RACKING HANDLE' CLOCKWISE TO COVER RACKING HOLE.

#### **CIRCUIT BREAKER RACK-OUT OPERATION SEQUENCE :-**

1. ENSURE THE FOLLOWING BEFORE RACK-OUT;
  - a VCB IS IN 'OPEN' CONDITION.
  - b VCB POSITION INDICATOR SHOWS 'SERVICE' POSITION.
2. ROTATE THE KNOB OF 'SOCKET FOR VCB RACKING HANDLE' ANTICLOCKWISE AND INSERT THE VCB RACKING HANDLE.
3. ROTATE THE RACKING HANDLE ANTICLOCKWISE UNTIL;
  - a THE VCB POSITION INDICATOR SHOWS 'TEST' AND
  - b THE HANDLE STOPS ROTATING.
4. REMOVE THE RACKING HANDLE.
5. ROTATE THE KNOB OF 'SOCKET FOR VCB RACKING HANDLE' CLOCKWISE TO COVER RACKING HOLE.
6. RELEASE PAD LOCK FROM DOOR HANDLE.
7. UN-LOCK DOOR BY MOVING HANDLE UP & SWING IT FOR OPENING.

### 5.1.3 - VCU Operating Instructions are as follows

#### **VACUUM CONTACTOR UNIT RACK-IN OPERATION SEQUENCE :-**

1. ENSURE THE FOLLOWING BEFORE RACK-IN;
  - A VCU IS IN 'TEST' POSITION.
  - B CONTROL PLUG IS PROPERLY CONNECTED TO VCU.
  - C VCU IS IN 'OPEN' CONDITION.
2. SWING THE DOOR FOR CLOSING AND LOCK IT BY MOVING HANDLE DOWN.
3. PAD LOCK DOOR HANDLE.
4. ROTATE THE KNOB OF 'SOCKET FOR VCU RACKING HANDLE' ANTICLOCKWISE AND INSERT THE VCU RACKING HANDLE.
5. ROTATE THE RACKING HANDLE CLOCKWISE UNTIL;
  - A VCU POSITION INDICATOR SHOWS 'SERVICE' AND
  - B MECHANICAL RESISTANCE IS FELT TO ROTATE THE HANDLE.
6. REMOVE THE RACKING HANDLE.
7. ROTATE THE KNOB OF; SOCKET FOR VCU RACKING HANDLE' CLOCKWISE TO COVER RACKING HOLE.

#### **VACUUM CONTACTOR UNIT RACK-OUT OPERATION SEQUENCE :-**

1. ENSURE THE FOLLOWING BEFORE RACK-OUT;
  - A VCU IS IN 'OPEN' CONDITION.
  - B VCU POSITION INDICATOR SHOWS 'SERVICE' POSITION.
2. ROTATE THE KNOB OF 'SOCKET FOR VCU RACKING HANDLE' ANTICLOCKWISE AND INSERT THE VCU RACKING HANDLE.
3. ROTATE THE RACKING HANDLE ANTICLOCKWISE UNTIL;
  - A THE VCU POSITION INDICATOR SHOWS 'TEST' AND
  - B THE HANDLE STOPS ROTATING.
4. REMOVE THE RACKING HANDLE.
5. ROTATE THE KNOB OF 'SOCKET FOR VCU RACKING HANDLE' CLOCKWISE TO COVER RACKING HOLE.
6. RELEASE PAD LOCK FROM DOOR HANDLE.
7. UN-LOCK DOOR BY MOVING HANDLE UP & SWING IT FOR OPENING.

**VCU Fuse replacement Procedure**

Follow the following procedure to replace the fuse of the vacuum contactor. Following step to be carried out to replace and for assemble the same instruction to be carried out reverse direction.

a. Remove front top cover as shown in Figure 5.1.3 B.

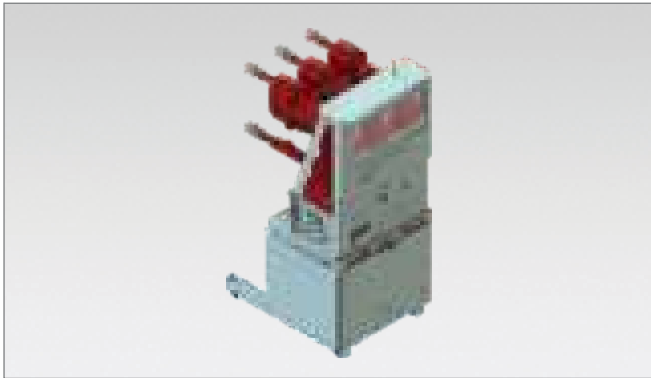

Figure 5.1.3 A - VCU with cover

c. Unfasten the front and rear fuse clam screw as shown in Figure 5.1.3 D.

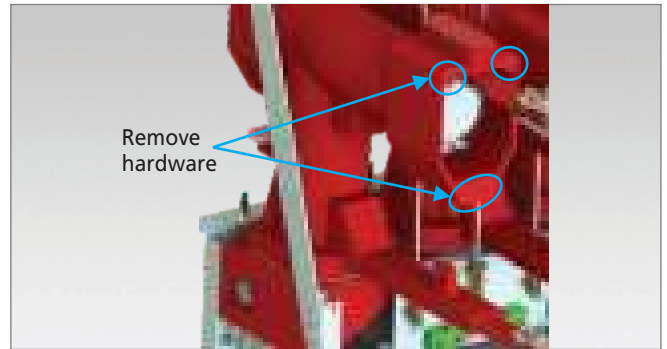

Figure 5.1.3 D

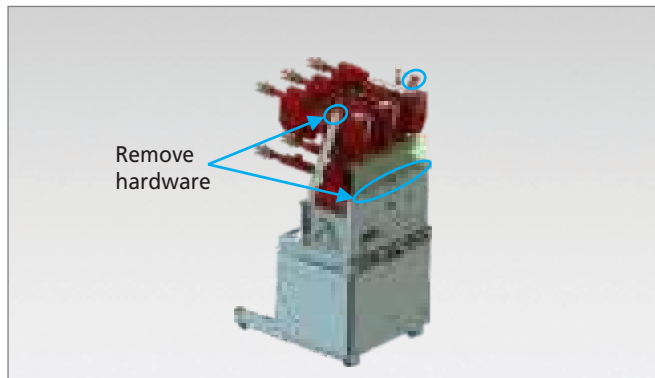

Figure 5.1.3 B - VCU without cover

d. Take out the HRC fuse as shown in Figure 5.1.3 E.



Figure 5.1.3 E

b. Remove front & rear epoxy cap as shown in Figure 5.1.3 C.

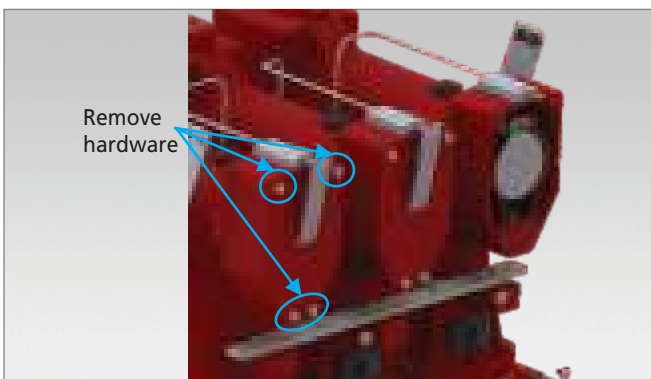

Figure 5.1.3 C

For assembly again, follow reverse path & ensure dimension as shown in Figure 5.1.3 F is 296mm.

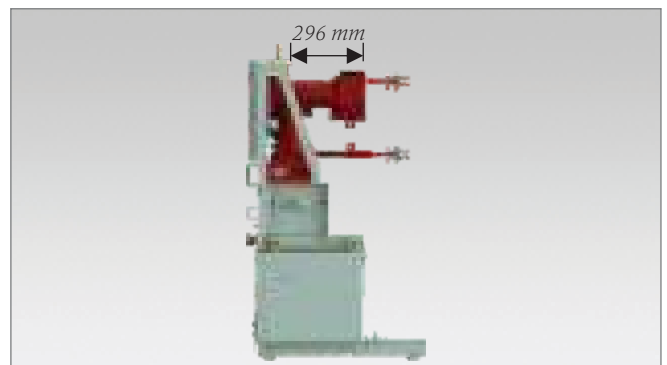

Figure 5.1.3 F

5.2 Earthing Operations

5.2.1 - Operating Procedure for Earth switch

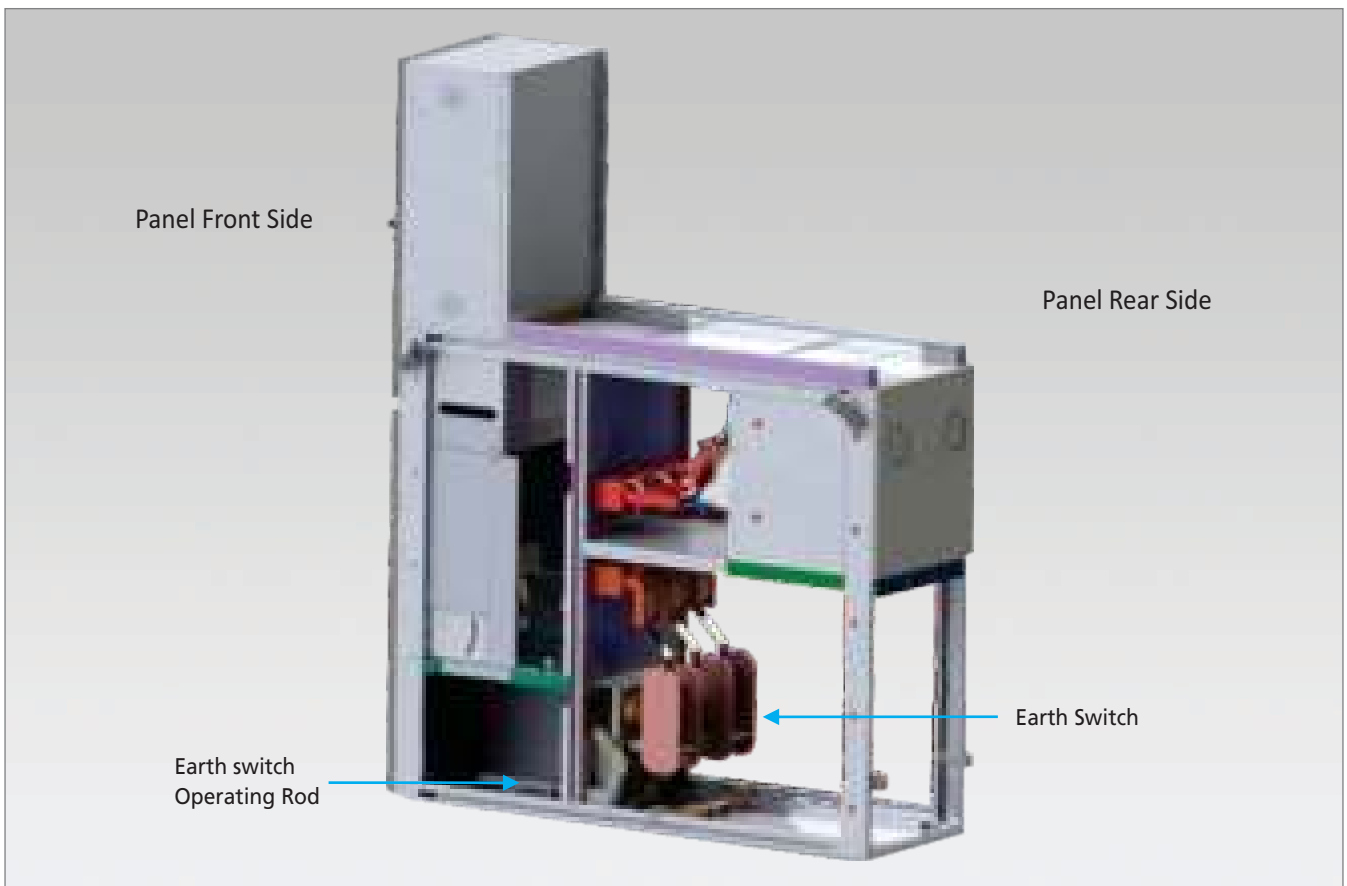

Figure 5.2.1 - Earth Switch Operation

**CABLE EARTH SWITCH OPERATING SEQUENCE**

1. ENSURE VCB AT "TEST" POSITION
2. PUSH AND HOLD BUTTON 'B', INSERT THE EARTH SWITCH EXTENSION SHAFT
3. RELEASE THE PUSH BUTTON
4. PLUG THE RATCHET TO THE EARTH SWITCH EXTENSION SHAFT
5. ADJUST THE RATCHET TO DESIRE POSITION
6. SLOT THE MAIN EARTH SWITCH HANDLE
7. ROTATE THE HANDLE ANTICLOCKWISE TO SWITCH ON THE EARTH SWITCH
8. ROTATE THE HANDLE CLOCKWISE TO SWITCH OFF THE EARTH SWITCH

5.2.2 - Earthing Truck



Figure 5.2.2 – Bus Earthing Truck

**Operating Instructions for Earthing truck**

- 1 EARTHING TRUCK TO BE INSERTED IN THE PANEL AFTER COMPLETE REMOVAL OF THE VCB. FOR LINE/BUS EARTHING TRUCK, ARM WILL BE AT BOTTOM LOCATION IF IT IS USED FOR LINE EARTHING & ARM WILL BE AT TOP LOCATION IF USED FOR BUS EARTHING.
- 2 IN LINE/BUS EARTHING TRUCK, ARMS SHOULD BE AT BOTTOM POSITION FOR LINE EARTHING AND AT TOP POSITION FOR BUS EARTHING. WHEN THE EARTHING TRUCK IS IN TEST POSITION, THE OPERATOR SHOULD CONNECT THE VCB PLUG TO THE EARTHING TRUCK FOR CONTROL SUPPLY.
- 4 CLOSE THE DOOR & INSERT RACKING HANDLE IN VCB RACKING HOLE & RACK-IN EARTHING TRUCK TO SERVICE POSITION.
- 5 OPERATOR CAN RACK IN THE TRUCK USING RACK-IN HANDLE ONLY AFTER PROPER CONNECTION OF THE CONTROL PLUG & DEAD LINE OR BUS (WHICHEVER SIDE IS BEING EARTHED).
- 6 IF LINE/BUS WHICHEVER IS TO BE EARTHED IS LIVE, THEN EARTHING TRUCK WILL GIVE AUDIO ALARM WITH HOOTER & ROTATION OF RACKING HANDLE WILL BE STOPPED SO AS TO PREVENT RACKING IN OPERATION OF EARTHING TRUCK.
- 7 IF LINE/BUS WHICHEVER IS TO BE EARTHED IS DEAD, THEN EARTHING TRUCK WILL BE RACKED IN TO SERVICE POSITION & SYSTEM WILL GET EARTHED.

## 5.3 - PT Operation Sequence

### PT RACK-IN OPERATION SEQUENCE :-

1. ENSURE THE FOLLOWING BEFORE RACK-IN;
  - (A) CONTROL PLUG IS PROPERLY CONNECTED TO PT.
2. SWING THE DOOR FOR CLOSING AND LOCK IT BY MOVING HANDLE DOWN.
3. PAD LOCK DOOR HANDLE.
4. ROTATE THE KNOB OF 'SOCKET FOR PT RACKING HANDLE' ANTICLOCKWISE AND INSERT THE RACKING HANDLE.
5. ROTATE THE RACKING HANDLE CLOCKWISE UNTIL
  - (A) MECHANICAL RESISTANCE IS FELT TO ROTATE HANDLE.
6. REMOVE THE RACKING HANDLE.
7. ROTATE THE KNOB OF 'SOCKET FOR PT RACKING HANDLE' CLOCKWISE TO COVER RACKING HOLE.

### PT RACK-OUT OPERATION SEQUENCE :-

1. ROTATE THE KNOB OF 'SOCKET FOR PT RACKING HANDLE' ANTICLOCKWISE AND INSERT THE RACKING HANDLE.
2. ROTATE THE RACKING HANDLE ANTICLOCKWISE UNTIL;
  - (A) THE HANDLE STOPS ROTATING.
3. REMOVE THE RACKING HANDLE.
4. ROTATE THE KNOB OF 'SOCKET FOR PT RACKING HANDLE' CLOCKWISE TO COVER RACKING HOLE.
5. RELEASE PAD LOCK FROM DOOR HANDLE.
6. UN-LOCK DOOR BY MOVING HANDLE UP & SWING IT FOR OPENING.

## 5.4 - Safety Shutters

Safety shutters will automatically open to uncover the fixed contact bushing spout when the VCB is inserted into its SERVICE position. Safety shutters will automatically close to cover the fixed contact bushing spout when the VCB is racked-out from its SERVICE position. Operations of these shutters are independent of each other. Independent padlocks are fitted to enable the shutters to be held open for maintenance or testing purposes.

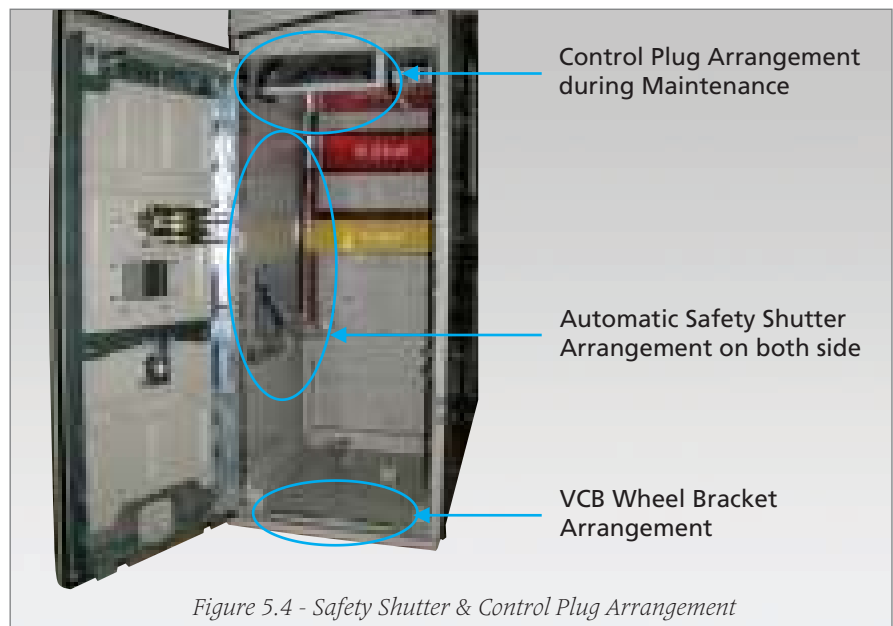

## 5.5 - Control Plug Arrangement

- A removable plug at the panel connects these control wires to the fixed wiring at the metering compartment.
- Whenever Panels are taken for Maintenance activity, please keep the control plug wire as shown in Figure 5.5 so as to avoid any disturbance & damages to Control plug wire.
- Ensure that the plug makes full connection before fastening the clasp.
- The breaker can only be racked into the SERVICE position when the secondary control plug is inserted.
- Control circuit plug can be inserted by moving the Red lever downwards.



Figure 5.5 - Control Plug Arrangement

## 5.6 - Anti Condensation Heater

- Space heater & Thermostat are located at Rear End of Panel in Cable Compartment.
- The space heater reduces humidity to prevent the formation of dews. This is achieved by circulation of air, which makes the air temperature in the switchgear uniform.
- For the indoor type switchgear, it is generally not necessary to operate the space heater while the unit is in service. Where the humidity is high, it is advisable to switch on the heater if the load is less than 50% of the panel rating.
- If the switchgear has been installed in a newly constructed building or in the basement where it may be subjected to very high humidity, the space heater must be operated immediately after installation.

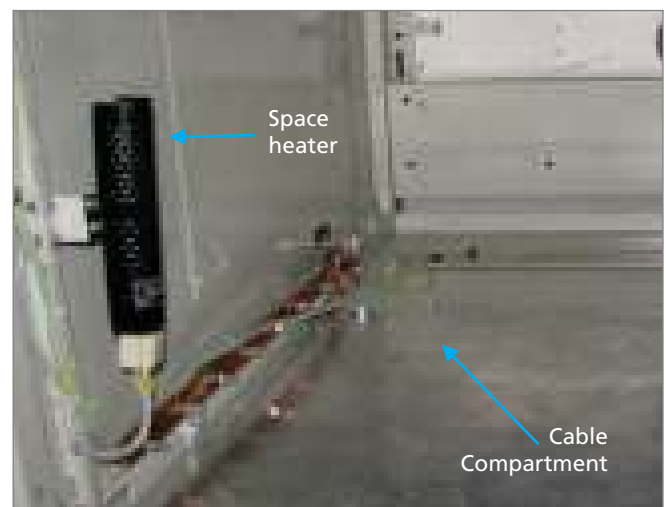

Figure 5.6 - Anti Condensation Heater

## 5.7 - VCB Racking Shutter Arrangement

- When VCB is to be inserted, manually open the VCB wheel bracket plates (both side) by sliding it to inside position.
- Insert the VCB through the wheel bracket.
- When VCB is in Test Position, Close this arrangement by sliding it to outside position. This will ensure that required IP class is maintained.

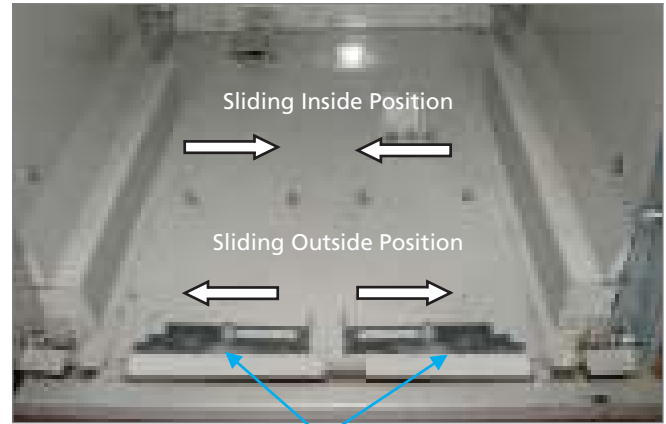

Figure 5.7 - VCB Wheel bracket Plates

## 5.8 Interlocks

### 5.8.1 - General Interlocks Provided

- A) The Racking-in & Racking-out of circuit breaker / contactor is not possible unless it is OFF.
- B) Circuit breaker / contactor can be closed only when it is in the service or test position.
- C) The operation of Circuit breaker / contactor is not possible while it is in the intermediate position.
- D) Circuit breaker / contactor cannot be racked-in unless the control plug is inserted.
- E) The operation of Circuit breaker / contactor is not possible unless control plug is inserted.
- F) It shall not be possible to remove the control plug while the Circuit breaker / contactor is in service position.
- G) It shall not be possible to remove the control plug while the Circuit breaker / contactor is in the intermediate position.
- H) It shall be possible to remove the control plug if Circuit breaker / contactor when in test disconnected position, irrespective of Circuit breaker / contactor status.
- I) Circuit breaker / contactor can be fully withdrawn out of its compartment only when the control plug is removed.
- J) It is possible to operate Circuit breaker / contactor unless earth switch is in 'open' position.
- K) It shall not be possible to move the Circuit breaker / contactor from disconnected position/test position into service position while earthing switch is closed.
- L) It is not possible to operate earth switch unless Circuit breaker / contactor is in test/disconnected position.
- M) It is not possible to close the earth switch with Circuit breaker / contactor in service or intermediate position.
- N) It is not possible for Circuit breaker / contactor to operate unless spring is fully charged.
- P) Rating error preventer is provided to prevent rack in with different rating of the Circuit breaker / contactor.
- Q) It shall not be possible to open the door while circuit breaker, switch or contactor is in service position.
- R) Door can be opened only if Circuit breaker / contactor is in Test position.
- S) Bypassing arrangement is provided to unlock the door in case of emergency.
- T) Safety shutter opens when the VCB / Contactor is racked-in to service position.
- U) Safety shutter closes automatically once the VCB / Contactor is withdrawn from the service position
- V) VCB / Contactor of same rating can be interchanged.

### 5.8.2 - Padlocking Facility

- A) VCB door key handle
- B) Safety shutter

### 5.8.3 - Visual Indications

- A) Position of earthing switch is indicated by a reliable indicating device.
- B) The status of Circuit breaker / contactor (Open or Close) is clearly indicated by a reliable indicating device.
- C) Service & test/disconnecting position of Circuit breaker / contactor is indicated by a reliable indicating device.
- D) Operation sequence instruction is clearly indicated in VCB front panel.
- E) 5 digit operation counter is provided on VCB front facia.
- F) Spring charged/discharged indicating flag is available on the VCB front facia.

# 6.0 TESTING AND COMMISSIONING

## 6.1 - Physical Inspection

- Check that the switchgears are installed in accordance to the drawings. The panel should be securely bolted to the floor and all the external controls and power cables correctly terminated.
- Remove common busbar chamber top covers and check that the interconnecting busbars are securely bolted.
- Insulation boots should cover all main busbar joints. Other exposed conducting parts should be taped with HV insulation tape.
- Check that the earthing links are correctly connected to the panel earthing bars and the latter to substation earth at one point.
- All moisture / dust must be removed / cleaned.
- Inspect all protection relays and meters. Remove shipping stops, if any.
- Check for zero setting of all indicating instruments and reset if necessary.
- All external and inter-panel control wirings should be checked for correct termination and continuity.

## 6.2 - Alignment Checks

The VCB is normally fully inserted at the SERVICE position if the panel is properly installed. Alignment checks on the VCB should include:

- The contact arms of the VCB are centre aligned against the fixed contacts at the bushing spout.
- The contact engagement of the breaker's finger contacts and fixed contacts is within 27mm for 1250A and 2000A breakers.

## 6.3 - Dielectric Tests

Insulation resistance tests are performed before and after the one-minute power frequency test.

### WARNING

- When H. V. testing is being carried out on the switchgears, it is mandatory that the area be cordoned off and safety notices clearly positioned.
- It is essential to earth the live parts of the switchgears after each test for a short duration to discharge them.
- All solid state relays must be isolated during this test.
- All current transformers are to be shorted and fuses for potential transformer removed

### 6.3.1 - Insulation test

#### i) Power circuit

- Disconnect power cables if they are connected.
- Remove all VT primary and control fuses.
- All CTs should be bridged using the CT shorting links provided.
- With all VCBs in OPEN condition, measure the insulation/ resistance of ERYB-RYB using a suitable meggar test set; normally a 5kV set.
- Close all VCBs.
- Repeat the measurement of the insulation resistance for R-E, Y-E, B-E, R-Y, Y-B and B-R. The value of the insulation resistance varies depending on the number of sections and the meggar set used. Normally, for new installations the value should exceed 500 megaohms.
- Insulation Resistance Tests should be repeated as described in 6.3.1 (d) to (f) after a one-min power frequency test. The insulation resistance readings may differ slightly from the initial ones.

#### ii) Control circuit

Insulation resistance test for control circuit is optional. If necessary, use a 500V meggar to measure the insulation resistance to earth. The insulation resistance should normally be greater than 1 mega-ohm.

## 6.3.2 - One Minute Power Frequency Test

### i) Power circuit

- Set up the same conditions as in 6.3.1 (a) to (d) and make sure that all VCBs are in the OPEN condition.
- Apply a high voltage between ERYB and RYB as per Table 6.3.2 for one minute. The test is considered to have passed if no disruptive discharges occur.
- Close all the VCBs as in 6.3.1 (e) & (f) and apply a high voltage between RYB and E as in Table 6.3.2 for one minute. The test is considered to have passed if no disruptive discharges flash-over occurs.

Rated Voltage (kV AC)	Power Frequency withstand Voltage (kV)*
3.6	10
7.2	20
12.0	28

Table 6.3.2: Rated Insulation level at rated voltage (As per IEC-60694)

**\*Note:** The power Frequency withstand voltage at site shall be 80% of the values as indicated in Table 6.3.2.

### ii) Control circuit

If the control circuit require a one-minute power frequency test, it should be performed at a voltage equal to  $(2 \times V + 1000)$  volts, where V is the rated control voltage. The test is considered to have passed if no disruptive discharge occurs within one minute of the application of the high voltage.

## 6.4 - Relay Injection Test

Secondary injection tests on protection relays are usually carried out in the factory. The relays should function satisfactorily once they are set up for commissioning.

It may be necessary to perform primary or secondary injection tests on site to establish that no CTs, relays and wirings are damaged during transportation.

- Check that all CT shorting links are at their original positions.
- Perform primary/secondary current injection tests on all relays wherever possible to establish that the tripping time corresponds to that shown on the relay manufacturer's tripping characteristic curve.

**Note:** During this test, the accuracy of the ammeter can be checked simultaneously.

## 6.5 - Operation Test

- Manually trip each VCB and withdraw it to the TEST position.
- Set all relays according to the co-ordination data.
- Select the REMOTE/LOCAL switches to LOCAL.
- Connect the control supply and test the VCB for motor charging, electrical closing and tripping operations.
- Check that all the indicating lights function normally.
- Reset all Flag Indicators.
- Check the operation of the shutters.
- Check that all interlock features function satisfactorily.
- Check all logic controls are in accordance to the Schematic drawings prepared by L&T.

## 6.6 - Final Check Before Energization

- Check and ensure that no foreign material has been left inside the switchgear. Replace all covers ensuring that all the screws are properly bolted down.
- Reconnect all external power cables.
- Insert all VT primary fuses and control fuses.
- Engage all VCBs into the CONNECTED position and ensure they are in OPEN position.
- Ensure all VCB & metering doors are tightly bolted down.
- Ensure earthing switches are disconnected from live (if inbuilt with panel).

The switchgears are now ready for energization.

# 7.0 MAINTENANCE

## 7.1 - General

Routine inspection should be conducted at regular intervals. Inspection of the switchgears should be made as soon as possible after the occurrence of a fault on the circuit. The switchgears should not be put into operation without a complete check and test after the clearance of a fault.

A maintenance program should be planned for the equipment. The frequency of the inspection and maintenance should be adjusted to take into account the environmental and operating conditions, and fault history. A recommended maintenance schedule is shown in below Table.

FREQUENCY	DESCRIPTION	WHAT TO DO
Daily	Physical appearance <ul style="list-style-type: none"> <li>Doors and covers to be bolted.</li> <li>Check for noise, smell or damage</li> </ul>	Visual inspection <ul style="list-style-type: none"> <li>Monitor meter reading</li> </ul>
Yearly	Complete switchgear	Routine maintenance

Table No – 7.1 Maintenance Schedule Table

For inspection and maintenance of other components in the switchgear panels, refer to the respective manufacturer’s manual.

## 7.2.1 - Visual Inspection

Visual inspection should best be carried out with the aid of an Inspection Check List. Table 7.2.1 provides a recommendation for such a checklist.

Service date		Weather condition	Ambient temperature		Checked by
Item	Part	Check point	Result		Remedy
			YES	NO	
Cubicle	External	Cover bolted?			
		Cover damaged?			
		Rust?			
		Discoloured?			

Table 7.2.1: Inspection Check List

Record the results of the inspection and action taken to remedy a defect on the checklist.

## 7.2.2 - Variants

Check on meters, protection relay flags etc. Record and monitor meter readings. Check if protection relays and annunciators have operated. Identify and eliminate fault. Reset and record.

## 7.2.3 - Check on metal parts

The degree of rusting and peeling of paint surfaces depends on the environment, service conditions and duration of use. Special paint finish is available on request. During the periodical checks, attention should be paid to the following points:

### a) Rust on metal parts

- Rusted moving parts that do not rotate or slide smoothly.
- Corroded spring and welded portions that suffer deterioration in their mechanical strength.

When the ambient condition is severe, the paintwork will deteriorate after a few years of service. It is recommended that those portions where the paint or coating is found to have peeled off or the surface rusty are repainted after the rust is removed.

### b) Peeling of paint or coating

- Peeling or discoloration of paintwork may be an indication of overheating. Use a temperature sensor to scan these metal surfaces. Record and monitor temperature variants.

## 7.2.4 - Noise Identification

A newly commissioned panel should function with no noise. Over the years, noise may be emitted. This may be noise from components, control and potential transformers or the panel. Identify the source of the noise for appropriate actions.

## 7.3 - Annual Maintenance

- It is done in principle with no voltage being applied and without dismantling the internal components. Devices are checked externally by visual and touch in accordance to the inspection schedule.
- If the main bus power supply is not shut down during inspection, use utmost caution for safety. A permit-to-work should be issued to the workers before the commencement of work and cancelled upon its completion.

## 7.4. SAFETY PRECAUTIONS

Routine maintenance of the switchgear should be carried out under the supervision of a competent person. Follow safety procedures during the maintenance of the switchgears.

- Ensure that the incoming high voltage supply is switched off. (Precaution should be taken to ensure that the incoming circuit cannot be re-energized).
- Trip the incoming supply VCB(s) and withdraw it from the VCB compartment.
- Earth the incoming cable.
- Issue Permit-to-work.

Carry out the following steps if the incoming supply cannot be switched off.

- Trip the incoming supply VCB(s) and withdraw it from the VCB compartment.
- Padlock the shutter labelled CABLE in its close position. The key should be in the possession of an authorized person.
- DO NOT EARTH THE INCOMING CABLE.
- Hang a warning notice and erect temporary barriers at the front and rear.

## 7.5 - Maintenance Procedures

Follow the following instructions to carry out the maintenance work.

### (a) Cleaning

All dust and dirt found on the top covers should be brushed off and cleaned prior to commencing any dismantling to minimize ingress of dirt into internal portions of the switchgear panel. Use lint-free clean cloth to clean the switchgears.

### (b) Insulation

All insulation surfaces should be cleaned and closely inspected for signs of tracking, treeing, blistering, and delaminating or mechanical damage. There should be no trace of grease on any part of the insulation surfaces especially at the spouts in the VCB compartment. Clean and dry insulators with a suitable cleaning agent.

**Caution:** Cleaning agent cannot be used on the black & grey surfaces of the bushing or on the copper bars.

## (c) Heater

The operation of all heaters, where fitted, should be verified.

## (d) Main and Earth busbars connections

Ensure that all connections are tight and that good contact is maintained.

This examination should include opening the boots for torque checks on the busbar bolt joints. There is a very slim chance for yearly shutdown of the bus, but checks should be done at least once in three years.

## (e) Secondary wiring and fuses

Ensure that the connections are tight and good contact is maintained. Verify the continuity of wiring to the fuses, instrument transformers, relays, instruments and other associated devices.

All contacts including that for the plug and socket contacts should be cleaned and lubricated sparingly with the correct lubricant. Fuses should be tested for continuity and inspected for signs of deterioration.

## (f) Auxiliary switches, indicating devices and interlocks

Auxiliary switches should be kept in a clean and operational condition because they are critical to the correct functioning of the equipment, especially the protection system.

Indicating devices such as semaphores should be tested for good operations and blown bulbs replaced. Interlocks and locking devices should receive particular attention, especially those associated with earthing and testing facilities. A strained or worn out device may result in a dangerous condition. It should be verified that any mal-operation is satisfactorily inhibited. Lubricate when necessary.

## (g) Shutters

The shutter mechanisms should be verified for correct operation and lubricated sparingly. This should normally be carried out immediately after the withdrawal of the VCB from its housing or immediately prior to re-energization.

## (h) Isolating contacts

The isolating contacts should be examined for discoloration and deformation due to overheating or environmental

contamination. Replace if necessary. Replace conductors if cause is overheating. For environmental contamination, eliminate source of contamination and clean the plating surface with appropriate cleaning agent.

## (i) Earthing switches

Earthing switches should be examined for correct operation and its contacts for good connections. The correct interlocking between the earthing switch and the VCB should be verified.

## (j) Meters, Transducers and Batteries

For the following items, refer to the relevant manufacturer's instruction manuals provided for operation checks:

- Protection relays
- Voltmeters and ammeters
- Energy meters (active or reactive)
- Transducers (voltage, current, watt, var)
- DC tripping/control supply

## (k) Protection relays

Wipe off any dust on the relay covers before removing them. Ensure that the covers are securely replaced to minimize the ingress of dust into the relays. Injection testing by primary injection is preferred. However, regular testing by secondary injection is sufficient to prove the integrity of the relays.

Tests should be made on protection relays to verify the operating and resetting times, the pick-up and drop-off values.

In the case of electro-mechanical relays, great care should be taken to avoid damage to the relay mechanisms when manipulating the induction disc of the relay.

In general, avoid subjecting protection relays to high-voltage tests. If such tests are required, ensure that the correct test voltages are applied to avoid damage to the relay, especially the solid state type.

If it is necessary to disturb any connections for testing purposes, ensure that these connections are correctly restored before returning the switchgears into service.

## (l) Current transformers (CT) and voltage transformers (VT)

Steps should be taken to ensure that voltage transformers are isolated and discharged to earth before commencing

examination. Care should be taken to ensure that the transformers are not made live inadvertently due to feedback from the secondary windings.

In the case of the CT, attention is drawn to the dangerous voltages that may result if the secondaries are open-circuited while the primaries are on load.

Any connections removed for checking/testing must be correctly replaced and securely tightened. Insulation resistance and continuity tests of the secondary windings should be carried out where possible.

Generally, check CT's and VT's for physical appearance and that all related connections are tight. The insulation material should be cleaned and closely examined for any signs of damage such as cracks, tracking marks or peeling.

In case of withdrawable VT's, the isolating contacts should be checked, cleaned and lubricated sparingly. The correct operation of safety shutters for the VT truck should also be verified. Primary and secondary fuses should be tested for continuity.

**(m) Control relays or contactors**

Inspect mechanical parts for free movement with the control and

main circuits isolated. Check the operation of the relays/contactors by energising the control circuit.

**(n) Final verification before re-energization**

A final check is to be carried out to ensure that the switchgears are restored to the original conditions and no tools are left inside the switchgears. Cancel the permit-to-work and warn all the workers of the re-energization.

**(o) Records**

Record actions taken and details of the corrective action on defect for future references.

**7.6 - VCB Maintenance And Inspection**

Check Points for Periodical Inspection.

General checks should be done one year after installation and once every 2 years thereafter, depending on severity of usage & environmental conditions. This should be done against a well documented schedule of requirements.

**7.6.1 - Maintenance and Inspection Schedule**

CHECK POINT	CHECK ITEM	CHECK METHOD	CRITERIA	WHAT TO DO	FREQUENCY
Entire VCB	Tightness of bolts and nuts	By tightening them with screw driver and wrench	No loose connections	Re-tighten loose connections	Once in 3 years
	Dust and foreign matter	Visual check	The VCB should be clear of dust and stains	Clean with a vacuum cleaner. Wipe with a clean, dry cloth and recommended cleaning agent (As66)	
	Deformation, excessive wear and damage	Visual check	No deformation, excessive wear or damage	Replace parts, if necessary	
	Lost or missing parts	Visual check	No missing parts	Replace missing parts	

CHECK POINT	CHECK ITEM	CHECK METHOD	CRITERIA	WHAT TO DO	FREQUENCY
Control Circuit	Electrical closing and tripping	Check at the "DISCONNECTED" position	The closing and tripping operations can be done smoothly	Check circuits and the closing and tripping devices.	Once in 3 years
			Motor can spring charge automatically	When the motor cannot spring charge, check if line fuse is blown. Replace if blown.	
Auxiliary switch	Terminal	Tighten with screw driver	No loose screws	Re-tighten	Once in 3 years
	Moulding and contacts	Visual check	No damage or deformation	Replace with damaged	
Operating mechanism	Dust and foreign matter	Visual check	There should be no dust and foreign matter	Remove foreign matter with pressurized air	Once in 3 years
	Smooth operation	Manual operation	Operation should be smooth	Clean off old lubricant and apply a small amount of fresh lubricant, if necessary.	
	Lubricant of bearing pins	Check by sight and touch			
	Shaft of closing and tripping portion	Visual check	Must rotate smoothly		
Main circuit disconnects/contact finger	Dis-colouration of contacts	Visual check	There should be a thin film of contact grease on the contact surface	Clean the contact surface of old grease and apply a thin film of new grease	Once in 3 years
Main barrier	Contamination and dis-colouration	Visual check	There should be no foreign matter	Clean with pressured air and then wipe with clean cloth	Once in 3 years
			There should be no tracking marks, cracks or damages	Replace when damaged	

CHECK POINT	CHECK ITEM	CHECK METHOD	CRITERIA	WHAT TO DO	FREQUENCY
Measurement of insulation resistance	Measuring location	Resistance	Tester	When the insulation resistance between the main circuit terminals is low, clean the surface of the vacuum interrupter with a dry cloth and then take the measurements again	Once in 3 years
	Main conductor-Ground/Main conductors	500M $\Omega$ or more	2000V		
	Control circuit Ground	2M $\Omega$ or more	500V		
Measurement of contact resistance	Across each set contacts	Resistance	Testing by Micro meter	Check, wipe and contact gaps	Once in 3 years
Timing Test	Across each set of contacts	Trip time & Close time		As per specs	Carried out when speed of operation is critical

7.6.2 - Checks on Vacuum

The relationship between the dielectric breakdown voltage and the vacuum pressure is shown below.

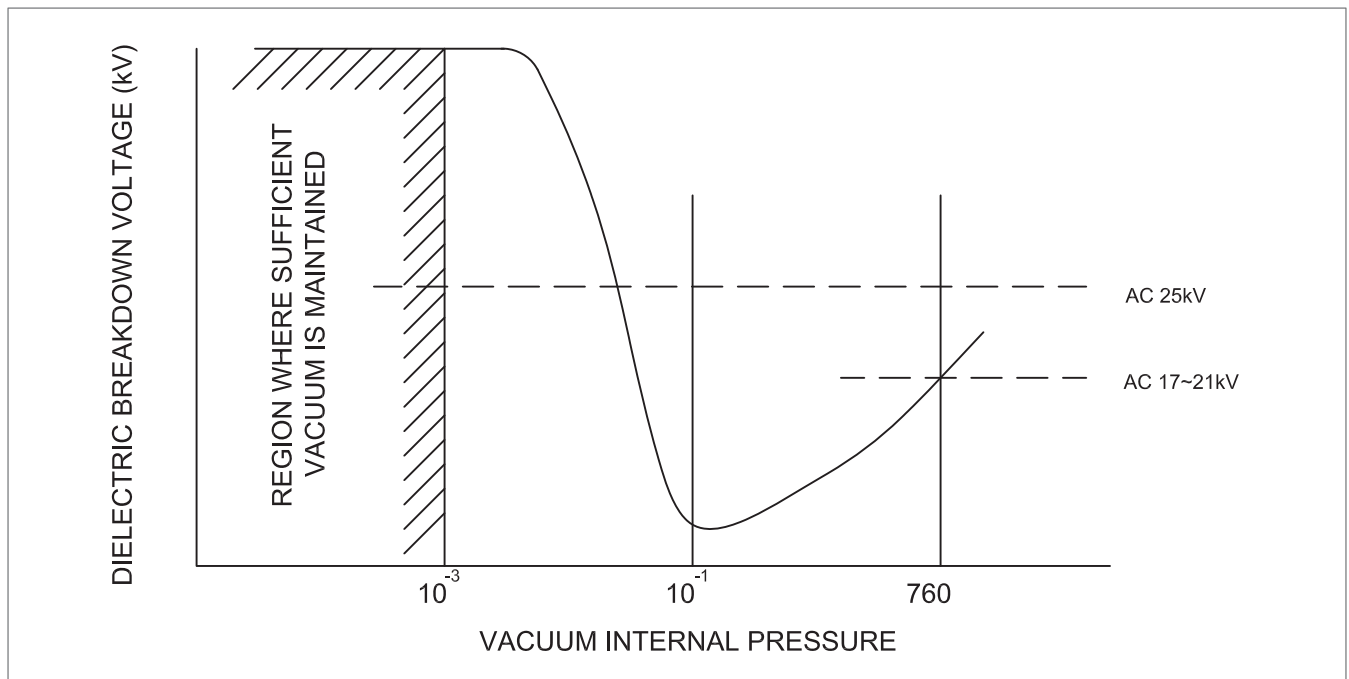

Figure 7.6.2 A – Dielectric Breakdown Voltage vs. Vacuum Internal Pressure

Breakdown will occur in the vacuum interrupter with vacuum less than 0.1mmHg when applied with a voltage of about 17 – 21kVAC. Therefore, the vacuum interrupter internal vacuum pressure can be checked by applying the voltage of 25 kV AC in this voltage withstand test.

When the internal vacuum pressure is not sufficiently high, breakdown will occur immediately. Hence 10 seconds of voltage application is sufficient.

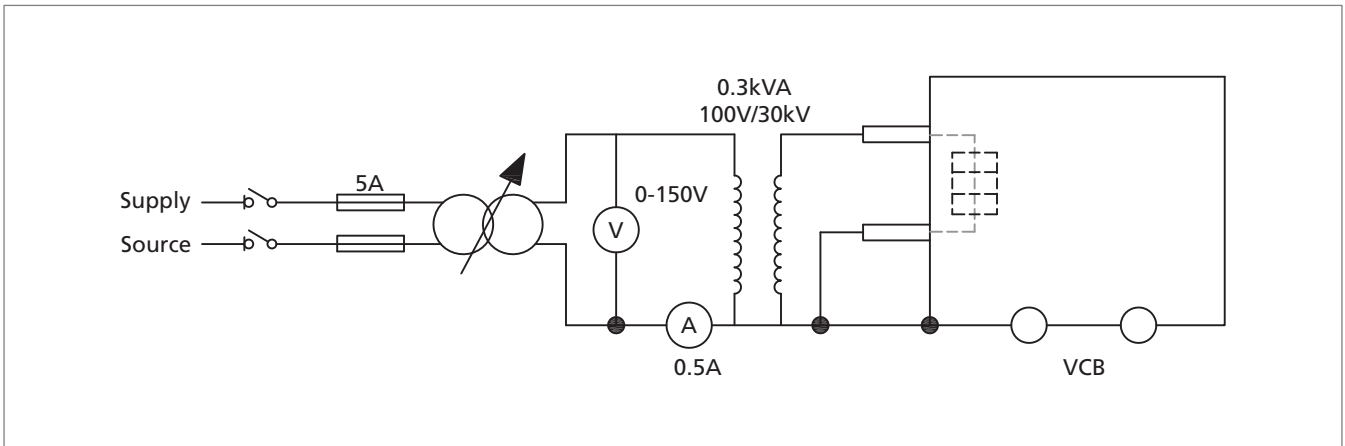

Figure 7.6.2 B – Set-up for High Voltage Withstand Test for Vacuum Interrupter

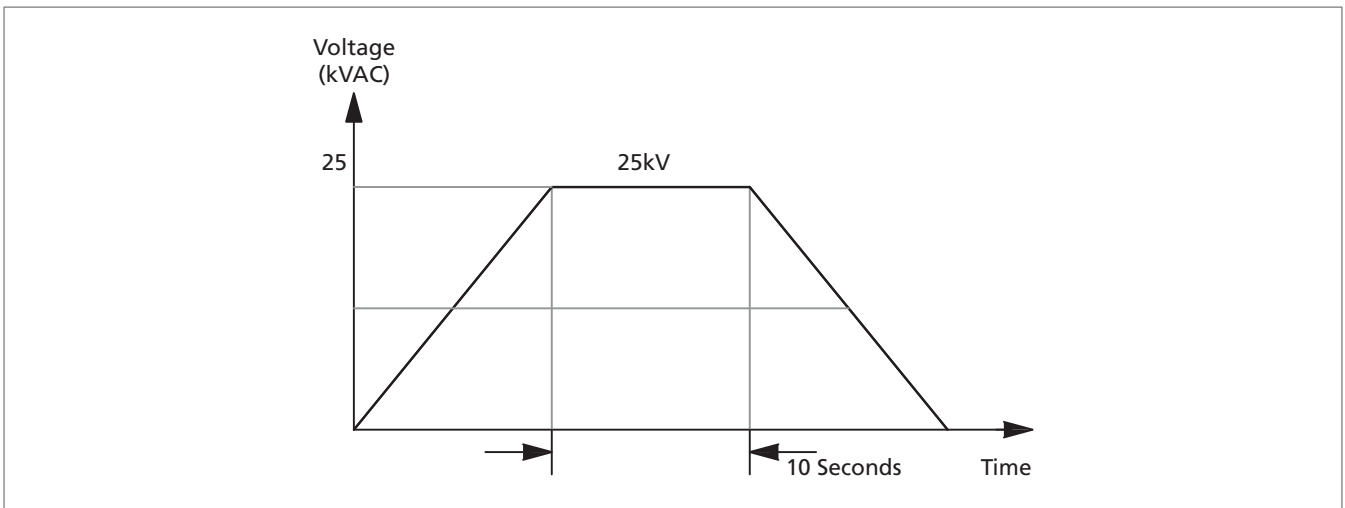

Figure 7.6.2 C – Application of High Voltage

If the ammeter indicates current flow in the process of increasing voltage, then the voltage must be reduced to zero and gradually increased again. Repeat this process 2 or 3 times. Interrupter is defective if the current increases with the voltage. The leakage current is almost zero for good interrupters.

## 8.0 TROUBLESHOOTING

The switchgears are manufactured under strict quality control and has undergone routine factory tests before dispatching from the factory. However, should any defects be found during daily or periodical inspections, investigate the cause of trouble and take the necessary action according to recommendations in Table 5 below:

Table 5: Trouble Shooting

Part	Trouble	Possible Cause	Remedy
DOOR	Handle cannot belocked	<ol style="list-style-type: none"> <li>1. Wrong key (if any)</li> <li>2. Internal mechanism rusted</li> <li>3. Internal mechanism faulty</li> </ol>	<ol style="list-style-type: none"> <li>1. Check key number</li> <li>2. Lubricate hole</li> <li>3. If in emergency, cut off the handle</li> </ol>
	Loose handle	<ol style="list-style-type: none"> <li>1. Fixing screws loose</li> <li>2. Internal mechanism worn out</li> </ol>	<ol style="list-style-type: none"> <li>1. Re-tighten the screws</li> <li>2. Replace handle</li> </ol>
STTUCTURE	Door warped and loose	<ol style="list-style-type: none"> <li>1. Loose screws at the hinges</li> <li>2. Hinge pin bent</li> <li>3. Door deformed by external force</li> </ol>	<ol style="list-style-type: none"> <li>1. Re-adjust the door and tighten the screws</li> <li>2. Rectify the hinge pin</li> <li>3. Repair the deformed portion</li> </ol>
	Internal noise	<ol style="list-style-type: none"> <li>1. Partition plates vibrating due to electromagnetic Induction/loose screws on partition plates</li> <li>2. Cable touching gland plate.</li> <li>3. Partial discharge due to stained or moist insulating material</li> </ol>	<ol style="list-style-type: none"> <li>1. For screwed on partition plates, retighten the screws.</li> <li>2. For gland plates, add sealing compound between cable and plate</li> <li>3. Shutdown power and clean the surface of the insulating material. Switch on the heaters to dry the air inside the cubicle</li> </ol>
MAIN CONDUCTORS	Connections overheated	<ol style="list-style-type: none"> <li>1. Loose bolts</li> <li>2. Overload</li> </ol>	<ol style="list-style-type: none"> <li>1. Re-tighten bolts to specified torque or replace busbar if necessary</li> <li>2. Limit current to the rated value</li> </ol>
	Ground fault or failed dielectric tests	<ol style="list-style-type: none"> <li>1. Insulators cracked</li> <li>2. Insulators stained with foreign matters and moisture</li> <li>3. Instrusion of rodents</li> </ol>	<ol style="list-style-type: none"> <li>1. Replace insulators</li> <li>2. Clean and dry insulators with suitable cleaning agent</li> <li>3. Plug gaps and openings and remove rodents</li> </ol>
CONTROL CIRCUIT	Extinction of indicating tights	<ol style="list-style-type: none"> <li>1. Bulb filament broken</li> <li>2. Fuse or resistor burnt</li> <li>3. Poor contact of auxiliary switches at the breaker</li> <li>4. Auxillary supply switches open circulated</li> <li>5. Limit switch contact shifted or faulty</li> </ol>	<ol style="list-style-type: none"> <li>1. Replace bulb</li> <li>2. Replace fuse or resistor</li> <li>3. Clean the auxiliary contacts</li> <li>4. Check MCCB of fuse and wire terminals</li> <li>5. Check limit switches contact and operation of limit switch.</li> </ol>

Part	Trouble	Possible Cause	Remedy
CONTROL CIRCUIT	Simultaneous lighting of both ON and OFF indicating lights	<ol style="list-style-type: none"> <li>Poor contact of breaker auxiliary switches</li> <li>Contact resistance increased due to dust contamination or oxidation of contacts (especially when they are not operated for prolonged period)</li> </ol>	<ol style="list-style-type: none"> <li>Clean contacts of auxiliary switch</li> <li>Operate the auxiliary switch several times</li> </ol>
	Poor operation of control circuits	<ol style="list-style-type: none"> <li>Loose screws on the terminal blocks</li> <li>Control circuit plug not properly connected</li> </ol>	<ol style="list-style-type: none"> <li>Re-tighten screws on the terminal blocks</li> <li>Re-insert the control circuit plug</li> </ol>
	Poor operation of instrument and relay	<ol style="list-style-type: none"> <li>Auxiliary switch contacts damaged by arcing</li> <li>Contact resistance increased due to oxidation or dust contamination</li> </ol>	<ol style="list-style-type: none"> <li>Clean the contact</li> <li>Replace the contacts if necessary</li> </ol>
VACUUM CIRCUIT BREAKER	VCB cannot close	<ol style="list-style-type: none"> <li>Circuit breaker not fully inserted</li> <li>REMOTE/LOCAL selector switch incorrectly selected</li> <li>Auxiliary supply MCCB open</li> <li>Control circuit plug not connected</li> <li>Control circuit voltage drop</li> <li>Closing coil burnt</li> </ol>	<ol style="list-style-type: none"> <li>Breaker to be aligned with the CONNECTED position sticker</li> <li>Switch to correct position</li> <li>Close the MCCB</li> <li>Connect the control plug</li> <li>Restore the voltage</li> <li>Replace the coil</li> </ol>
	VCB cannot open	<ol style="list-style-type: none"> <li>REMOTE/LOCAL selector switch incorrectly selected</li> <li>Auxiliary supply MCB/switch open</li> <li>Control circuit voltage drop</li> </ol>	<ol style="list-style-type: none"> <li>Switch to correct position</li> <li>Close the MCB/Switch</li> <li>Restore the voltage</li> </ol>
	VCB cannot be inserted into cubicle	<ol style="list-style-type: none"> <li>Wrong rating of breaker</li> <li>Lock lever does not lift up due to the CLOSED position of breaker</li> </ol>	<ol style="list-style-type: none"> <li>Insert the breaker of the correct rating</li> <li>Trip the breaker</li> <li>Adjust the shutter mechanism, lubricate the moving part</li> </ol>
SHUTTER	Shutters cannot close	<ol style="list-style-type: none"> <li>Shutter damaged</li> <li>Moving parts poorly adjustment and lubricating oil deteriorated</li> </ol>	<ol style="list-style-type: none"> <li>Repair damaged shutters</li> <li>Adjust moving parts and apply lubricating oil</li> <li>Clean the moving part</li> </ol>
	Shutter cannot open	<ol style="list-style-type: none"> <li>Pedlock left locked on the shutters</li> <li>Shutter deformed</li> <li>Moving parts poorly adjusted and lubricating oil deteriorated</li> </ol>	<ol style="list-style-type: none"> <li>Unlock the padlock</li> <li>Repair deformed shutters</li> <li>Adjust moving parts and apply lubricating oil</li> </ol>

# 9.0 DO'S AND DON'TS

## IN VCB AND VCB PANEL (CLOSE DOOR OPERATION PANEL)

Read Operation & Maintenance Manual carefully before doing any Operation on the Switchboard.

### DO's

- Perform all the operations in CLOSE door condition only. (Rack in, Rack out, Open and Close)
- Ensure following before racking the VCB from TEST to SERVICE position.
  1. VCB is in TEST position.
  2. VCB is in OPEN condition.
  3. Earth switch is in OFF condition if provided.
  4. Control circuit plug is fully engaged. Red lever on control plug mechanism should come upward direction when CONTROL PLUG is fully engaged.
- Ensure VCB compartment door is fully closed and all the bolts on VCB compartment door are fully Tightened.
- Earth switch should be operated when VCB is in DISCONNECTED position.
- Always cross check rating of the VCB before insertion inside the panel.
- Ensure complete switchboard is free from dust and any other foreign particles.
- Ensure all openings including hole provided for earthing connection are properly closed with seal to avoid any vermin/ reptile entry.
- Ensure that the shutter assembly is unlatched before inserting the VCB into the panel.
- Please keep the heater "ON" in all Panels including Dummy panel.

### DON'Ts

- Do not apply any flammable lubrication on the busbar joints or VCB finger contacts.
- Do not perform any operations in OPEN door condition. (Rack in, Rack out, Open and Close).
- Do not operate the interlocking lever on VCB.
- Do not try to rack in VCB when control plug is not engaged. By operating the VCB forcefully it may damage the control plug mechanism.
- Do not try to rack in VCB when VCB is in CLOSED condition.
- Do not try to operate Earth switch when VCB is in CONNECTED position if provided.
- Do not operate the VCB when castle lock is in LOCKED condition.
- Do not operate the padlock handles if door bolts are not tightened fully by Allen key.
- Do not try to insert wrong rating VCB inside the panel.
- Do not insert VCB without unlatching the shutter assemblies.
- Do not try to by pass VCB compartment door interlock when the feeder is in Live condition.

## 10. MANDATORY SPARES

1. VCB / VCU Racking Handle
2. VCB spring charging handle
3. Manual Trip Rod (if applicable)
5. Earthing Switch operating handle (if applicable)
6. Trip Coil
7. Closing coil
8. Spring Charging Motor
9. Indications Lamps
10. PT Fuse
11. VCU Fuse
12. SDS VCB Clamp
13. Electrical Contact grease (Preferred - Mosil EC-111)
14. Mechanical Grease (Preferred - Mosil GM-00)
15. Touchup Paint

**Note** - While Ordering Spares please mention "Board Drawing Number" as given in Switchboard Name Plate.  
(Other spares available on request)





## Sales Offices - India

### Bengaluru

Area office, 38, Cubbon Road  
Bengaluru 560001  
Tel: 080-25020319  
Fax: 080-25596397  
Email: ese-chn@Lntebg.com

### Chennai

L&T Construction Campus  
TC-1 Building, II Floor  
Mount-Poonamallee Road  
Manapakkam, Chennai 600 089  
Tel:+91-44-2270 6801  
Fax:+91-44-2270 6930  
Email: ese-chn@Lntebg.com

### Hyderabad

Post Bag 12, Vasantha Chambers  
2 floor, 5-10-73, Fateh Maidan Road  
Hyderabad 500 004  
Tel: +91-40-6672 0210  
Fax: +91-40-2324 2356  
Email: ese-hyd@Lntebg.com

### Kolkata

Post Bag 619  
3-B, Shakespeare Sarani  
Kolkata 700 071  
Tel. : +91-33-4400 2550 / 2558  
Fax. : +91-33-22827587 / 1025  
Email: ese-kol@Lntebg.com

### Mumbai

Gate No. 7, North Wing, Level 2  
Saki-Vihar Road, Powai  
Mumbai 400 072  
Tel:+91-22-6705 3083  
Fax:+91-22-6705 1556  
Email: ese-mum@Lntebg.com

### New Delhi

Post Bag 6223  
32, Shivaji Marg  
New Delhi 110 015  
Tel: +91-11-4141 9620/9942  
Fax: +91-11-4141 9625  
Email: ese-del@Lntebg.com

### Vadodara

Radhadaya Complex, J. P. Road  
Vadodara 390 015  
Tel: +91-265-66136 37/38  
Fax: +91-265-2336 184  
Email: ese-vad@Lntebg.com

## Sales Offices - International

### Australia

TAMCO Electrical Industries Australia Pty  
Ltd  
31 Kitchen Road, Dandenong 3175  
Melbourne, Victoria, Australia  
Tel:+613 9706 7288  
Fax:+613 9706 9112  
Email: sales@tamcoaustralia.com.au  
www.tamcoaustralia.com.au

### India

Gate No.7, Saki-Vihar Road  
North Wing, Level 1  
Mumbai 400 072  
Tel:+91-22-6705 2813  
Fax:+91-22-6705 1024  
Email: ese-intl@Lntebg.com

### Indonesia

PT. TAMCO Indonesia  
F-36, Jalan Jababeka Raya  
Jababeka Industrial Estate  
Cikarang Utara, Bekasi, 17530,Indonesia  
Tel.: +62 21 893 5070  
Fax: +62 21 893 5071  
Email: inquiries@tamco.co.id  
www.tamco.co.id

### Kenya

1A, 3rd Floor  
Westlands Business Park  
04, Chiromo Lane  
Westlands, PO Box no. 13903 - 00800  
Nairobi, Kenya  
Tel. : +254-770-412 008  
Email: ese-kenya@Lntebg.com

### Malaysia

TAMCO SWITCHGEAR (MALAYSIA) SDN  
BHD  
Sub Lot 24, Lot 16505, Jalan Keluli 1  
PO Box 2100, Bukit Raja Industrial Area,  
Section 7  
40802 ShahAlam, Selangor, Malaysia  
Tel: +603 3361 8200  
Fax: +603 3341 6200  
Email: tamco@tamco.com.my  
www.tamco.com.my

### Oman

P.O.Box 598, Ruwi, Postal Code-112  
Sultanate of Oman  
Tel:+968 98034317  
Mob:+968 98034317  
Email: ese-oman@Lntebg.com

### Qatar

2 & 3rd Floor, Building No. 209  
Zone 42, Street 230  
Najma Intersection, Opp: Doha Cinema  
C-Ring Road,P.O Box No- 24399  
Doha, Qatar  
Tel: +974-44-239 000  
Fax: +974-44-551 286  
Email: ese-qatar@Lntebg.com

### Saudi Arabia

L&T Electricals Saudi Arabia Company  
Limited - L. L. C  
MH-4, Plot: 17+19  
2nd Industrial Area, Dammam  
Kingdom of Saudi Arabia  
Tel: +966-3-8127708  
Fax: +966-3-8127780  
Email: Ltesa@Lntebg.com

### UAE

2202, 22nd floor  
Green Emirates Tower - A  
Electra Street, P.O. Box 30803  
Abu Dhabi, UAE  
Tel. : +971-2-676 5988  
Fax. : +971-2-676 6399  
Email: ese-uae@Lntebg.com



### Larsen & Toubro Limited, Electrical Systems & Equipment - Head Office

Gate No. 7, North Wing, Level 1, Saki-Vihar Road, Powai, Mumbai 400 072  
Tel: +91-22-6705 1748 Fax: +91-22-6705 1556 Email: ese-cmt@Lntebg.com  
Website: www.Lntebg.com CIN: L99999MH1946PLC004768

The information contained herein is correct at time of printing, but as the products and its manufacturing processes are being developed continuously, this information is subject to change without notice and the company cannot be held liable for any alleged misinterpretation howsoever arising.

Registered Office:  
L&T House, N. M. Marg  
Ballard Estate  
Mumbai 400 001, INDIA