

Operating Instructions
and
Maintenance Manual for
Low Voltage AC Induction Motors



Motors for the Long Run!

C O N T E N T S

Item	Pages
1. Inspection & Storage	1 – 2
2. Pre-Installation Checks	2 – 3
3. Installation	3 – 9
4. Routine Maintenance	9 – 12
5. Trouble Shooting	12 – 13
6. Renewal & Spares	13

WELCOME TO THE MARATHON ELECTRIC FAMILY

Your motor has been manufactured in one of the most modern facilities in World. Each component and complete motor assembly has been subjected to a series of strict quality checks. Our manufacturing plants are certified by BVQI for ISO9001 Quality Management system.

We are therefore able to guarantee your motor against manufacturing defects for a period of 12 months from this date subject to the following terms and conditions.

HEALTH AND SAFETY AT WORK

Electric motors manufactured by MARATHON Electric comply with all Indian/ IEC requirements, relating to such machines, and to specific customer requirements.

TEFC cage motors complying to IEC requirements additionally comply to relevant EU safety regulations as per EN60204-1. TEFC cage motors are also available complying to both IEC and NEMA specifications. Flameproof motors are manufactured complying to all certification requirements from relevant statutory authorities and have BIS marking.

The motors are carefully inspected and individually tested before despatch to ensure that they comply with the requirements of relevant specifications in respect of both electrical and mechanical features and they are safe in operation in the specified environment.

Motors must be installed as per the local electrical code / regulations, by an authorised person. Motors must be protected against overload and short circuit.

The purpose of this manual is to emphasize the importance of observing essential installation and maintenance procedure. Reasonable attention to these few points would amply be repaid by trouble free service with low maintenance expenses.

We have tried to include as much data as possible. However, it should be appreciated that in a condensed booklet of this type, it is not possible to include complete details on all different types of motors encountered in various industrial fields. However, should further information be required, it will be furnished on request. Communication should state the particulars stamped on the rating plate, including Motor Serial Number (S.O. No.).

Should any problems be encountered which are not covered by this publication, a team of experienced engineers is available to advise on correct procedures.

For any such requirement, please get in touch with our nearest branch office.

1.0 RECEIPT AND STORAGE

1.1 Receipt & Inspection

- Unpack carefully and check for transit damage which may have caused damage/ breakage of any part. The machine should be thoroughly cleaned from dust, dirt and flakes of packing material. – In case of transit damage contact local MARATHON Electric branch office/ Divisional HQ/ insurance surveyor.
- Terminal entry – Check and ensure that terminal box is properly located as per requirement.
- Ensure free rotation of motor shaft.

1.2 Handling

Motors without an eyebolt should be lifted directly by the body of the motor utilizing the terminal box and frame. The fan housing should not be used for lifting purpose.

When an eyebolt is provided, ensure that it is screwed firmly into the frame upto the eyebolt shoulder. With horizontal mounting motors, lifting should be vertical from eyebolt.

Vertical motors are provided with two lugs / eyebolts diametrically opposite to each other around the circumferential periphery. Eyebolt provided for flange mounted motors are only suitable for taking an additional load not exceeding the motor weight.

Before lifting the motor, the weight of the motor should be referred and considered.

In case of very large or special motors, sometimes special instructions/ diagrams are provided for proper handling. These should be followed to avoid damage and ensure safe handling of the machine.

1.3 Storage

- *Site* – Indoor storage is always preferable as it provides controlled atmosphere. Motors stored outdoor requires better care and more frequent check-ups.

Storage site should be free from vibration. Induced vibration due to heavy vehicles passing nearby or a heavy machine running aside is not desirable too.

- *Atmosphere* – The place must be clean, dry. Moisture can rust steel parts, cause pitting on the bearing and seriously reduce the insulation resistance.

Due to note ideal storage conditions, the winding could absorb moisture necessitating drying out operation.

- *Protection* – Protect from dust, dirt, oil, moisture, etc. Rust preventing coating applied to the exposed parts, should be checked and should be applied again as required.
Motors should be covered and should be kept on a raised platform. Seal/ Plug the cable entry hole to avoid entrapment of moisture and vermin.
- *Space heating* – Space heaters, when provided, should be left energized for the duration of storage to prevent moisture condensation.
- *Bearings* – Rotate shaft at least once per month to prevent brinelling and hardening of grease. Grease life is approximately two years on storage subject to implementation of above procedure.
- *Periodic Inspection* – The motor should be inspected at a regular interval during storage and its insulation resistance should be checked time to time.

2.0 PRE-INSTALLATION CHECKS

2.1 Measuring insulation resistance

The insulation systems used on the windings of the machines are designed to give reliable service life under the specified operating conditions. To ensure that the integrity of the insulation had been maintained during periods of storage, it is essential to check insulation resistance value for both stator and rotor (slip ring motors) windings.

Hence before installation, the stator and rotor (slip ring motors) winding insulation resistance should be checked using a 500V megger. The insulation resistance, measured between the terminal and the frame, with the machine cold, should not be less than ‘machine voltage in kV + 1’ meg ohms.

2.2 Drying out

If it is less than this recommended value, stator (Rotor for slip ring motor as applicable) winding need to be dried out by one of the following methods:

- *Space Heaters* – Electric Space Heaters if provided may be useful for drying out windings where the moisture is on or close to the surface of the outer layer of insulation. However, if the moisture has penetrated the winding, especially on old machines, then the method is unlikely to be successful on its own.
- *Oven drying* – The machine can be baked in an oven not exceeding 120 deg. C temperature.

Ensure a good circulation of air inside the baking oven.

Check the insulation resistance at regular intervals and log the reading so that rate of drying can be evaluated. Drying out would continue until the I.R. value reaches 1 Meg ohms. Drying process should be unhurried.

- *Low voltage current heating* – Where a controllable Low Voltage DC or single phase AC Supply is available, the heating effect caused by such supply can be used for drying out the windings. However, care must be taken to ensure that current value does not exceed 50% of the rated value with the voltage generally being 10% to 20% of the rated value. In the case of slipping motors care must be taken to short circuit the slipping and the rotor mechanically locked.
- *Heaters around machine* – In case of non-availability of above facilities, Carbon filament lamps / heaters / infra red lamps can be placed inside / around the machine ensuring that the hot bulbs / elements do not make contact with the windings. The winding should be suitably enclosed leaving a hole at the top of the enclosure for moisture escape.

While drying out is in progress, the insulation resistance should be checked at regular intervals and the readings logged. It will be noted that the insulation resistance will drop considerably as the machine warms up, but as drying out proceeds it will gradually increase. The drying out should be continued as long as the insulation resistance rises, or until it is above the minimum acceptable value.

The insulation resistance of heaters (if provided) can also be measured with a 500V Megger. Measurements on thermistor circuits must be made at a voltage less than 100V e.g. by use of an multimeter.

Safety Precautions

Before attempting any insulation resistance test, it is essential to earth the frame of the machine and any parts of the winding not being tested, including all auxiliary circuits.

Dry insulation with a high resistance is capable of holding on electrical charge for several hours after removal of the applied voltage. Hence, for reasons of both safety and accuracy, it must be ensured that the winding under test is adequately earthed both before and after the application of the test potential.

2.3 Bearing lubrication

The grease life is approximately 2 years during

storage. Hence in case of long storage, the condition of lubrication grease must be checked by opening the bearing covers of both driving and non-driving end. If the condition has deteriorated or quality seems insufficient, it should be removed and replaced by fresh recommended grease (lithium base Grease MP-3 grade of Bharat Petroleum or Servogem 3 of IOC or equivalent).

Grease used in motors without sealed bearings of Paharpur Works : Lithumbase Grade 2, EP Type, Brand ALIHEX 20 of Tide Water.

Caution : Overgreasing and mixing of two grades of grease is detrimental to the bearings, usually resulting to overheating.

3.0 INSTALLATION

3.1 Location and Environment

The Motor should be placed in a dry, clean and well ventilated location so that heat generated during operation can be dissipated away easily and there is no chance of re-circulation of heated air discharged from the motor. There must be an adequate, unrestricted and undisturbed supply of the cooling medium to ensure that the ambient temperature is maintained as specified in the design.

Screen Protected Motors should essentially be placed in a well-sheltered location.

There should be sufficient space around the machine so that there is no problem of movement of operating personnel for maintenance and dismantling.

Unless the motor is designed specially, it should not be allowed to come in contact with corrosive gases or acids or any fumes etc.

3.2 Installation checks

- Ensure satisfactory earth system of motor and controller. Installation must be approved by a qualified person.
- Ensure supply details correspond with motor rating plate.
- Ensure that air vents and lubricators are not choked.
- Ensure that motor drive shaft on the coupled installation is adequately protected from accidental contact by personnel.
- Clean corrosion preventative lacquer from shaft using white spirit or petrol, taking care that none enters the bearing housing.

- Ensure free rotation of the shaft.
- Check insulation resistance.
- Ascertain that air-flow is unrestricted and that adjacent sources of heat (furnace, hot blooms etc.) do not affect cooling of the motor – standard motors are designed for a maximum ambient of 40°C.
- The motor foundations must be adequate, otherwise there is a possibility of vibration (Refer Section 3.3).
- Remove drain plugs and refit after draining any condensate.

3.3 Foundation

The foundation of a machine should be sufficiently rigid to take care of vibration and to maintain proper alignment between the motor and the load. Concrete foundations are always recommended but for unavoidable circumstances, steel structure could also be used with special attention to rigidity and less vibration.

For concrete masonry foundations a mixture of cement, sharp sand and broken stones in the volume ratio of 1:2:4 respectively will prove useful. The ingredients are mixed vividly when dry and water is added slowly to make a paste, which is just sufficiently wet to pass freely into all corners and crevices. The foundation should be allowed to stand for at least 7-10 days, before the machine is put onto it.

For structural steel frame works, it should be looked upon that the difference between its natural frequency of vibration and operating speed of the machine is at least 20%.

3.3.1 Levelling and grouting

It is very important that a machine is properly leveled and solidly grouted.

- The motor and the driven apparatus is placed

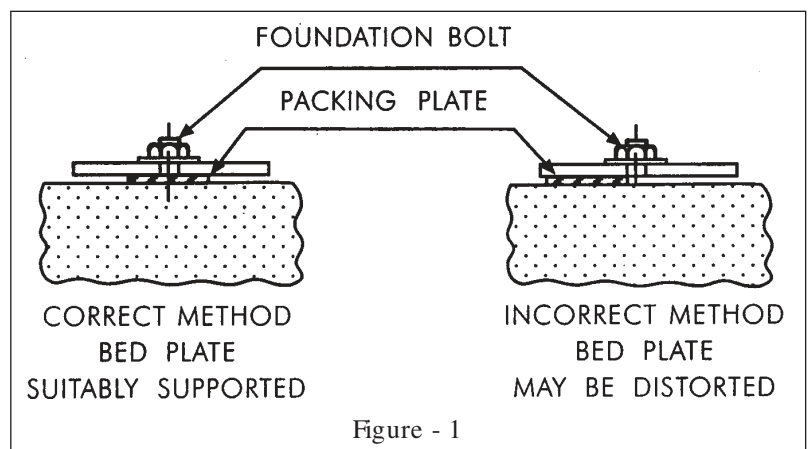

Figure - 1

on a base slide rail which in turn is placed on the foundation with steel packing plates (Shims) in between them. The shims are evenly placed 25 to 30 cm apart and are situated close to and on each side of every foundation bolt as shown in figure to protect the base plate from suffering distortion by providing mechanical support to it.

- Now the holding down bolts (provision for which are made earlier) are grouted in. When the mortar has set hard the bedplate with motor is to be leveled up and if found to have warped due to machining, it is leveled by adding or removing shims by lifting the bedplate by jacking equipment. The motor has to be aligned with sufficient accuracy with the driven apparatus. Now the foundation bolts are tightened and finally the alignment is checked again.
- For large motors extra strength is provided by using machined flanges of Steel T section, i.e. girders, which are sunk into the foundation, the uppermost machined flange projecting slightly above the concrete level. The numbers of such girders depends upon the load to be supported and are positioned to lie under the heavy load points (below).
- A 1:2 mixture of cement and sand, with sufficient water to make it thin is used to fill up any gap or space around foundation bolt upto the level of foundation.

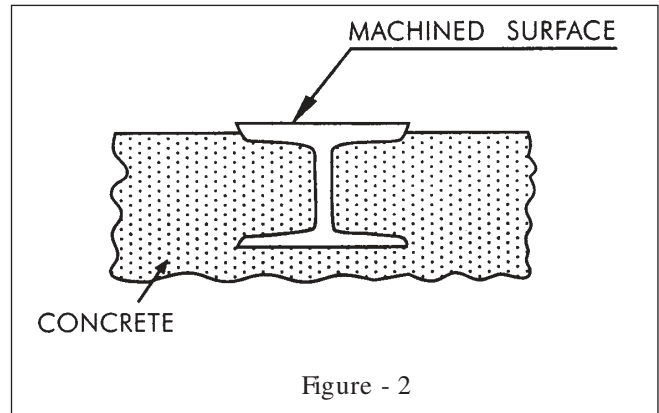

Figure - 2

- The bottom of the base plate is covered with the above mixture with the help of a temporary wooden carb, puring it from under the base plate continuously till it stands about 25 mm above the base plate. The entire process is completed within a short uninterrupted span of time to ensure free undisturbed flow of the fluid to all parts.

3.3.2 Foundation Bolt

Foot mounted must be bolted down to the baseplate or slide rails, using four correctly sized bolts each with lock washer and flat washer of diameter suited to spread the compression load. Flange mounted motors must be attached to the driven face by a correctly sized bolt with washers in each bolt hole provided for the purpose. Bolt sizes for mounting purposes for standard TEFC motors are given in the table below :

Table – 1

Frame Size		Foot Mounting Bolt Size	Flange Mounting Bolt Size		Face Mounting		
IEC	NEMA		IEC	NEMA	Bolt Size		Hole depth
63		M6	M8		M5		8
71		M6	M8		M6		8
80	56	M8	M10		M6		9
90S/L	143/ 145	M8	M10	M10	M8	3/ 8 UNC	12
100L	–	M10	M12		M8		12
112M	182/ 184	M10	M12	M10	M8	3.8 UNC	12
132S/ M	213/ 215	M10	M12	M16	M10	1/ 2 UNC	15
160M/ L	254/ 256	M12	M16	M16	M12	1/ 2 UNC	19
180M/ L	284/ 286	M12	M16	M16			
200L	324/ 326	M16	M16				
225S/ M	364/ 365	M16	M16				
250S/ M	404/ 405	M20	M16				
280S/ M	444/ 445	M20	M16				
315S/ M	504/ 505	M24	M20				
355S/ M/ L	585/ 586/ 587	M24	M20				

3.4 Recommendation on drives

3.4.1 Pulley drive (Belt Coupling)

- Belt drive is not recommended for 2 pole motors of sizes 160 and above.
- The Belt must be smooth and flexible and the Pulley should be well balanced.
- Pulley centre distances should not be less than 4 times the diameter of the larger pulley, unless on idler pulley is used.
- The belt tension should be optimum, i.e. neither too tight nor too loose.
- V-Belts may stretch during the first few hours of running. It is therefore advisable to check the tension after one hour running and again after two days of running.
- Vertical belt drive is not desirable and sliding bedplates should not be used.
- Belt size and space for belt on pulley should be properly matched. One of the following three figures, (in Fig. 3) shows the correct positioning of belt into pulley.

The diagram given below (Fig. 4) shows the recommended method of aligning a pulley drive and slide rail positioning for belt tension. The wire should touch pulleys at points marked with an arrow.

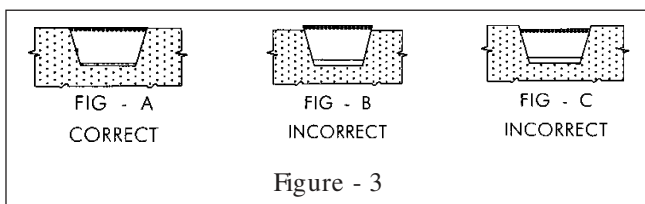

Figure - 3

3.4.1 Correct Tensioning of V and Flat Belt Drives

The high performance of modern belt drives particularly flat belts cannot be achieved without correct tensioning.

To check for correct tension proceed as follows :

- 1) Measure the span length
- 2) At the centre of the span apply a force of right angles to the belt to deflect one belt 16mm per metre of span length.
- 3) Compare this force with value in table below:

V-Belt Section	Force required to deflect Belt 16mm per metre of span	
	Kilogram force (kgf)	Newton (N)
A	1.0 to 1.5	10 to 15
B	2.0 to 3.1	20 to 30
C	4.1 to 6.1	40 to 60

3.4.2 Gear & Chain Drive

With chain or gear drive, it is essential that all wheels are fully meshed in both depth and along the width of face and the chains must run centrally on their sprockets.

For gear drives where pitch line exceeds 280M per minute, pinions made of paper or fabric are used to reduce excessive noise. If the alignment is not parallel and meshing of gear and chain drives is not good, excessive vibration or bearing trouble may occur and ultimately may result in a broken or bent shaft.

Bevel and single helical gears should be avoided for gear drive because these produce thrust which may be beyond the capacity of bearings. When these gears are to be used, it must be conveyed to the works at the time of ordering.

3.4.3 Direct Coupling

It is essential that motor and driven equipment be aligned correctly with driving and driven shafts in parallel, in order to ensure long trouble free service. Direct Coupled Motors may be coupled to the load through flexible half couplings. This reduces stresses due to slight misalignment.

Following procedures may be followed for alignment of coupling :

- Completely strip couplings of bolts, rubber bushes, or springs. Replace one bolt loosely (or a piece of wood across spring grooves) so that both half couplings will rotate together.
- Fasten a magnetic base dial gauge on one half coupling (see Fig. 5A) ensuring that the fastenings are rigid enough to have no effect on the dial gauge.
- Rotate both shafts and take readings on the periphery at four positions 90 degrees apart and record the results.
- Take readings on the faces of the couplings using a feeler gauge (see Fig. 5B) at four positions 90 degrees apart, record the readings.
- Adjust the machines laterally and adjust the shims if required, until, with the motor holding down bolts fully tightened, the arithmetical

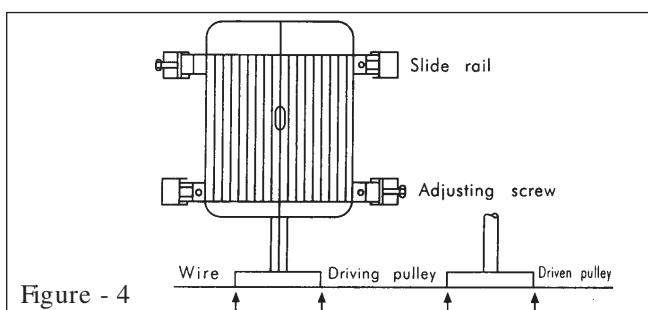

Figure - 4

difference between the readings is not greater than 0.05 mm.

- On holset type couplings, 2 dial gauges shall be used. (see Fig. 5C).

Rigid coupling requires much more accurate alignment and can cause severe stresses in the shaft in case of slight misalignment.

Since it is not easy to achieve the high level of alignment necessary for use of rigid coupling, our prior approval before installation is necessary where such coupling is used.

3.5 Shaft fittings

When fitting pulleys and half couplings, first check that bores and keyways are within their correct tolerances, are free from burrs, and that the pulley dimensions are within the recommended limits. (see Table 2). A 'tap-on' fit should be indicated for a

pulley and a 'force' fit for coupling.

The dimensions of shaft extension diameters and corresponding pulley/ coupling bores for standard TEFC motors are given below :

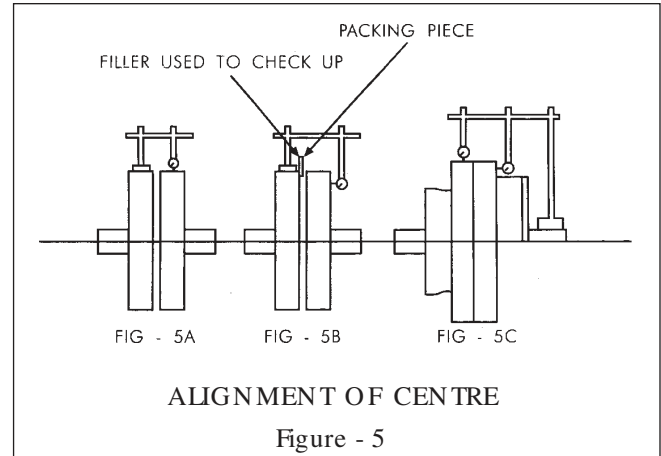

Table-2

FRAME SIZE		POLE	SHAFT DIA. NOM.	COUPLING		PULLEY		KEYWAY WIDTH		KEYSEAT DEPTH	
TEFC	SPDP			BORE	TOL	BORE	TOL	NOM.	TOL	NOM.	TOL
D63		AIL	11	10.977	+ 0.018	11.000	+ 0.018	3.985	+ 0.030	12.8	+ 0.1
D71		AIL	14	13.977	+ 0.018	14.000	+ 0.018	4.985	+ 0.030	16.3	+ 0.1
D80		AIL	19	18.977	+ 0.021	19.0	+ 0.021	5.598	+ 0.030	21.8	+ 0.1
D90		AIL	24	23.977	+ 0.021	24.0	+ 0.021	7.982	+ 0.036	27.3	+ 0.2
D100/ 112		AIL	28	27.977	+ 0.021	28.0	+ 0.021	7.982	+ 0.036	31.3	+ 0.2
D132		AIL	38	37.977	+ 0.025	38.0	+ 0.025	9.982	+ 0.036	41.3	+ 0.2
D160 KS160		AIL	42	41.977	+ 0.025	42.0	+ 0.025	11.979	+ 0.043	45.3	+ 0.2
D180	C160	AIL	48	47.977	+ 0.025	48.0	+ 0.025	13.979	+ 0.043	51.8	+ 0.2
KS180	CW160										
D200 KS200	C180 CW180	AIL	55	54.975	+ 0.030	55.0	+ 0.030	15.979	+ 0.043	59.3	+ 0.2
D225		2				Not recommended					
KS225	C200 CW200	AIL		59.975	+ 0.030	60.0	+ 0.030	17.979	+ 0.043	64.4	+ 0.2
D225		4-8				Not recommended					
D250	C225	2	60	59.977	+ 0.030	Not recommended		18.000	+ 0.021	64.4	+ 0.2
KS250	C225 CW225	4.8		64.977	+ 0.030	65.018	+ 0.030	18.000	+ 0.021	69.4	+ 0.2
D280	C250 C280	2	65	64.977	+ 0.030	Not recommended		18.000	+ 0.021	69.4	+ 0.2
D250		4-8	70	69.977	+ 0.030	70.018	+ 0.030	20.000	± 0.026	74.9	+ 0.2
D315	C315	2		69.977	+ 0.030	Not recommended		20.000	± 0.026	74.9	+ 0.2
KS280	C250 CW250	4-10	75	74.979	+ 0.030	75.018	+ 0.030	20.000	± 0.026	79.9	+ 0.2
KS315	CW280	4-10	80	79.977	+ 0.030	80.018	+ 0.030	22.000	± 0.026	85.4	+ 0.2
D315	C280	4-10	85	84.972	+ 0.035	85.022	+ 0.035	22.000	± 0.026	90.4	+ 0.2
	C315 CW315	4-10	90	94.972	+ 0.035	90.022	+ 0.035	25.000	± 0.026	95.4	+ 0.2
K355		2	75	74.977	+ 0.030			20.000	± 0.026	79.9	+ 0.2
K355		4-12	90	89.972	+ 0.035			25.000	± 0.026	95.4	+ 0.2
K400		4-12	100	99.972	+ 0.035			25.000	± 0.026	105.4	+ 0.2
K450		4-12	110	109.972	+ 0.035			28.000	± 0.026	116.4	+ 0.2

Table - 2A

FRAME SIZE	SAFET DIA.	COUPLING		PULLEY		KEYWAY WIDTH		BOTTOM OF KEYSEAT TO SHAFT SURFACE	
		NEMA	NOM.	BORE	TOL	BORE	TOL	NOM.	TOL
56	15.875	15.852	-0.013	15.873	-0.013	4.775	+0.051	13.132	-0.381
143/145	22.225	20.202	-0.013	22.225	-0.013	4.775	+0.076	19.583	-0.381
182/184	28.575	28.552	-0.013	28.575	-0.013	6.350	+0.076	25.044	-0.381
213/215	34.925	34.902	-0.013	34.925	-0.013	7.925	+0.076	30.505	-0.381
254/256	41.275	41.252	-0.025	41.275	-0.025	9.525	+0.076	35.966	-0.381
284/286	47.625	47.602	-0.025	47.625	-0.025	12.700	+0.076	40.411	-0.381
324/326	53.975	53.952	-0.025	53.975	-0.025	12.700	+0.076	46.863	-0.381
364/365	60.325	60.302	-0.025	60.325	-0.025	15.875	+0.076	51.333	-0.381
404/405	73.025	73.002	-0.025	73.025	-0.025	19.050	+0.076	62.230	-0.381
444/445	85.725	85.702	-0.025	85.725	-0.025	22.225	+0.076	73.152	-0.381
504/505	85.725	85.702	-0.025	85.725	-0.025	22.225	+0.076	73.152	-0.0381

NOTE : For 2 pole motors pulley drive not recommended.

Care should be taken to remove the rust preventive lacquer from the shaft using petrol or white spirit. The pulley/ coupling bore should be thoroughly cleaned and smeared with oil with the key in position. The non-driving end of the shaft should be supported by holding a block of wood against shaft extension. This involves removal of fan cowl/ airshield. The supporting block of wood will relieve the bearing of any strain imposed during the fitting of the coupling or pulley.

With the key in place carefully shrink, press or drive the pulley or half coupling on the shaft to the required position or shaft shoulder.

Safety Instruction

It is important that adequate guards must be provided to cover all types of drive system, and that personnel are protected against accidental contact with rotating machinery.

3.6 Electrical Connection

Motor must be connected to the electric supply strictly in accordance with the method of connection provided in motor nameplate and diagram label normally provided at the back of terminal box cover. The alternative connection schemes are shown as follows.

To reverse rotation, interchange any two leads.

Note : If the motor is externally star connected ensure that star point is properly shorted with shorting link.

Before refitting the terminal box ensure that the sealing gasket is between terminal box/ terminal box cover and terminal box/ Cable plate are in position and that the terminal box fixing screws are securely tightened down into position without trapping motor internal leads.

Safety Note

It is important that motor enclosure is soundly earthed by metallic earthed conduit run, by separate earth continuity conductor or by separate earth bonding, but in all cases the installation must be made and tested and approved for this feature by a qualified person before the supply is applied to the motor.

Ensure that supply details correspond to the data carried on motor name plate.

Check and ensure that all electrical connections, plugs, sockets are properly secured before switching the supply.

Check and ensure that all protective circuits are properly connected.

For motors using unidirectional fan (as used sometimes for 2 pole motors) it is recommended to check the direction of rotation prior to coupling with the driven machinery.

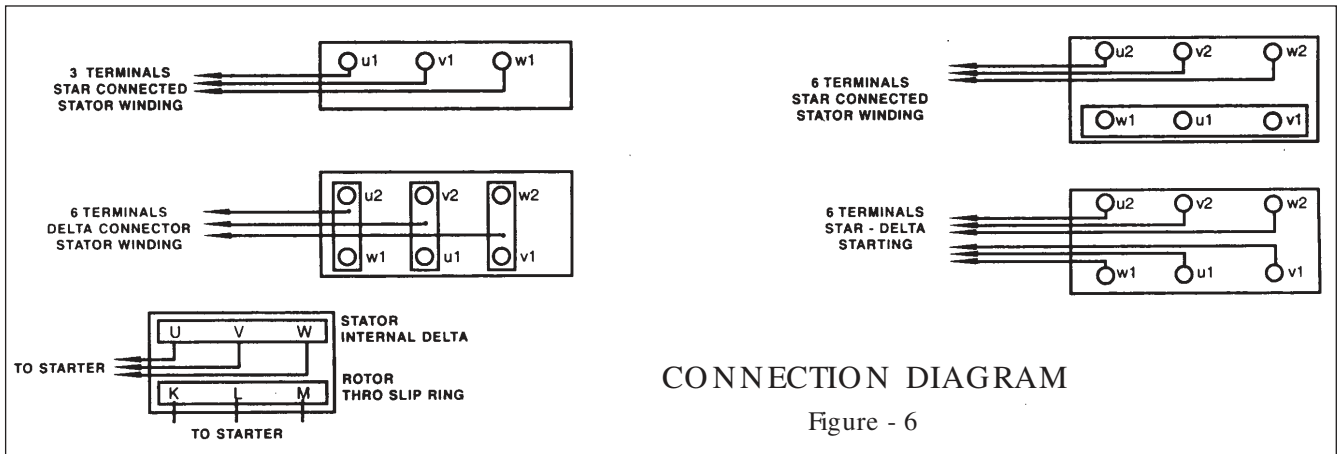

3.7 Starting up

3.7.1 Ensure all available protective devices such as RID, BID, Thermistor are connected in the circuit. MARATHON Electric does not take responsibility of failure of a product if the protection devices available in the motor remains unutilized.

3.7.1 Sq. Cage Motors

Sq. Cage motors are normally started by one of the following means.

- a. Direct On Line (D.O.L) Starting
- b. Reduced Voltage Starting (Star-Delta or Auto transformer Starting)
- c. V.V.V.F (variable voltage variable frequency) supply.

3.7.2.1 Direct-On-Line Starting

When using direct on line (DOL) starting, the motor is isolated from the 3 phase supply by means of a contactor. There may be two or three positions of the operating handle. One is simply OFF and ON or RUN. Another OFF, START and RUN. In the start position the overload is cut out – this is the difference between the two arrangements.

When using the two-position starter, the handle is simply shifted from OFF to ON position. In case of three position starter, the handle is moved from OFF to START position, given some time to accelerate and then moved to RUN position. If the Motor fails to start, the handle should be immediately returned to OFF position and never should be moved to RUN position as that may be harmful for both motor and starter.

3.7.2.2 Reduced Voltage Starting

There are basically two types of reduced voltage starting, one is Star-Delta Starting and the other is Auto Transformer Starting. The object is to reduce the starting inrush current drawn by the motor. The

starting current is reduced in proportion to the square of the voltage, i.e. $(1/3)^2 = 1/3$ for Star Delta and (per unit voltage tap) for Auto Transformer Starter. This fact must be kept in mind when using any of these methods, as the load torque at any speed during starting must be appreciably less than the effective motor torque to enable the motor to start up the rated speed.

When the equipment driven by the motor is to start on load, the motor may not attain full speed and may run at a fraction of rated speed at which the motor torque and load torque are equal. In this case, the starter has to be changed to RUN position to impress the full voltage on the stator winding to enable the motor to attain full speed. But if the motor speed has not already attained about 75% speed then the sudden increase in current due to this change over from START to RUN is considerably high. In such situation the only achievement is the reduction in duration of the high starting current. The advantage of these types of Starters is realized fully when the motor is started on reduced load.

If after starting, the motor is observed to run in wrong direction, or if the rotation of the motor is to be reversed for any reason. It is sufficient to interchange any two of the three supply leads.

Squirrel cage motors are often started with the help of a soft starter (electronic starter-variable voltage – fixed frequency type). The selection of the “ramp” of such a soft starter must be made with careful matching of the motor and the load characteristics. Wrong setting can result burning out of the motor. In the event of limitation of current of the supply source at site, please recheck the compatibility of the starter and the motor with the load. If in doubt please ask MARATHON Electric.

It may be clarified that motors for inverter fed applications are special and calls for special considerations for commissioning.

3.7.3 Slip Ring Motors

Slip ring motors are normally started and run by one of the following means.

- a. Rotor Resistance Starter
- b. Thyristor control with Rotor Resistance Starter

3.7.3.1 Rotor Resistance Starter

There are two control gears – one is switch or circuit breaker in the Stator circuit and another is variable resistance in the rotor circuit. At start, the handle of the short circuiting gear is placed in the START position if there is a start circuiting gear with the motor. Also, the rotor resistance control handle must be in the OFF or START position.

Now the starter switch or breaker is closed and the rotor slipring resistance is cut off in steps, allowing some time in each step to allow the motor to accelerate by moving the controller handle gradually from START to RUN or ON position.

At the last step the motor acquires full speed and the short circuiting gear handle (if any) is moved to the RUN position. If the Motor fails to start as soon as the rotor controller handle is operated or does not attain full speed within 30/ 35 seconds, the stator switch or breaker should be opened and the starter handle should be returned to OFF position immediately.

3.7.3.2 Thyristor Control

In this method stator voltage is controlled by phase angle control of thyristors and simultaneous adjustment of external resistance in rotor circuit. Careful adjustment of voltage of thyristor and selection of rotor resistance as per requirement of the load must be done.

4.0 ROUTINE MAINTENANCE

Preventive maintenance encompasses planning and action necessary to identify and rectify deteriorating influences or conditions before they advance to the stage where the initiative is removed from preventive maintenance and placed in repair maintenance.

Logic and experience clearly indicates that preventive maintenance, properly applied, reduces repair costs and increases production as a result of reduced downtime. By careful planning much preventive maintenance work can be done while the machine is in full production. During this period vibration, heating, current balance and temperature rise should be noted and recorded. More stress should however be placed on safety while examining motors under operating conditions. Sufficient

information must be available on the record card to serve the purpose of the card.

Moisture, oil, dirt, grease and carbon or metallic dust is the principal causes of electrical breakdown. As far as it is practicable, machines should be kept clean and dry both internally and externally. Dust and grease should be removed from ventilating ducts, cores, windings and protecting mesh cover, as accumulation of foreign matter will affect the ventilation and machine temperatures.

During the first few weeks of service a new machine should receive particular attention. New installations are likely to cause teething-trouble in this period during which the moving parts are gradually setting down to working surfaces and temperatures.

Careful attention to the following routine inspection may help prevent serious trouble developing later.

- Ensure that all external cables are adequately cleated and are properly secured.
- Check the security of all electrical connections with the motor isolated from the supply. Ensure that all terminals (Terminal block) are clean and tight.
- Check and ensure that the windings and bearings are not overheating and that the motor runs quietly and smoothly.

The windings demand frequent attention if the machines are working in damp, humid or dirty situations, or in excessive temperatures, and insulation must be kept clean, otherwise earth faults or short circuits may occur.

- Check the security of all fixing bolts, couplings, coupling guards etc.
- Check that cowl intake vents are not choked. Choked cowl intake may restrict the flow of cooling air and cause overheating. Compare the actual load current, Supply voltage with the full load current, Rated voltage given on the rating plate.
- Ensure that load current does not exceed motor name plate full load current. Ensure that supply voltage and frequency is within the tolerance band specified in the catalogue/ test certificate. The line voltages and currents are also to be checked to ensure balanced loading within specified limits.
- Check that the Carbon Brushes are sitting properly on the slipring and the tension of the holders are uniform. The brushes should not vibrate in the holders when the motor is running.

Note :

Should any fault occur which cannot be analyzed, please communicate with the nearest MARATHON Electric establishment or agent or directly with the Works. A Staff of experienced engineers is available who can assist or advise customers on the rectification of any fault or breakdown.

Lubrication :

A motor cannot run satisfactorily unless due attention is paid to its bearings. Ball and roller bearings for MARATHON Electric make motors have been designed for a minimum L10 working life of 20,000 hours and in order to meet this requirement attention should be given to the points elaborated below.

Double sealed life lubricated bearings are provided for small motors upto 180Lframe size motors. These bearings need to be replaced at the end of working life. Motors with lubrication points require regular lubrication.

Unshielded bearings are provided with Lithium Based Multipurpose Grade 3 grease, or Alithex 2.0 of Tide Water (see section 2.3) which has an operating temperature of -20C to 120C. Servogem No. 3 of I.O.C or MP3 grease of Bharat petroleum or Equivalent Grease should be used for lubrication.

Grease should preferably be added whilst the machine is running, and should be free from contamination by dirt or water. The importance of ensuring cleanliness of grease fittings before and after lubrication cannot be over emphasized. Mix-up of different types of grease should not be done, because this might lead to bearing failure. Over greasing causes leakage into the windings and overheating of bearings and hence is not at all recommended.

The regreasing interval depends on bearing size and operating R.P.M.

The details of bearings used on different motors are given separately in the Appendix.

Overhaul (Scheduled Maintenance)

Motors are simple in construction but even so every care should be exercised when dismantling or reassembling it. Damage may be caused to the winding, bearing, shaft and rotor if handled carelessly.

Dismantling Procedure :

- a) Remove motor from driven equipment.
- b) Draw the pulley or coupling from the motor shaft using withdrawal equipments.

- c) Remove shaft key.
- d) Remove fan cowl/ airshield.
- e) Remove fan fixing bolt/ pin (As applicable) and ease fan off the shaft twisting slightly to clear.
- f) Remove NDE bracket fixing screws.
- g) The rotor can now be withdrawn by tapping off the NDE bracket.
- h) Remove NDE bearing cap screws (or bearing retaining clamps) and tap end – bracket from rotor.
- i) Remove bearings using suitable drawing gear applying pressure to inner race only.
- j) In case of slipping motors disconnect rotor terminal cables from brush holders before drawing out rotor.
- k) To remove slipping, first remove brush and brush holders. Next disconnect slipping from rotor winding cables.

Then unscrew the locking nut on the shaft to loosen and draw out the slipping.

Removal & Replacement Of Bearings

Ball/ Roller Bearings should be replaced only by equivalent bearings or similar types, fits and clearances.

New bearings should not be exposed to dust and dirt, and should only be opened on a clean bench and installed immediately. It is not necessary to remove the rust preventive Oil which manufacturers use unless this has hardened in storage, in which case the bearing should be washed in warm mineral oil. When a bearing is removed for inspection or other reason and is refitted, the bearing housing and journal clamps should essentially be cleaned and filled with fresh grease.

The devices used for withdrawing bearings should where possible exert pressure on the inner race,

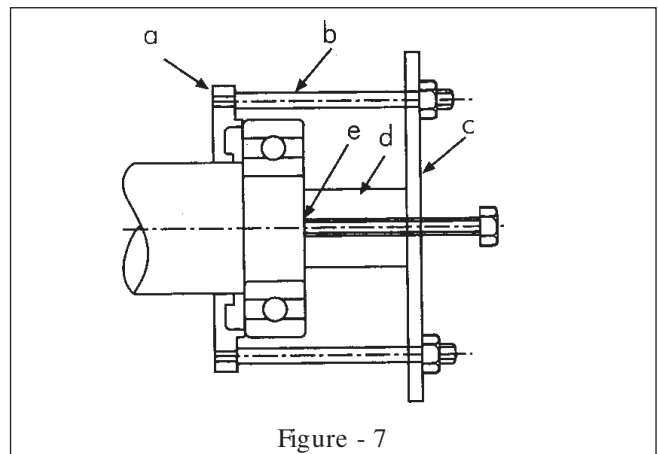

Figure - 7

and the pressure should be uniformly distributed, parallel with the shaft and at right angles to the bearings.

When a bearing is removed by means of the journal clamp, place packing between the clamp and the inner race if the clamp spigot contacts the outer race before the centre boss contacts the inner race. If the journal clamp is split, an extractor must be used (Figure 7).

The inner clamp (a) can be used to withdraw a bearing by replacing the studs by longer ones (b) or adding extensions to the existing studs with coupling nuts. The studs pass through holes in a plate (c) placed against the end of the shaft, and are tightened up evenly until the bearing is drawn off its seating. Diagonally opposite studs to be tightened a half-turn at a time to obtain a steady even pressure. Where there is no shaft beyond the bearing, packing (d) longer than the bearing width will be necessary.

Alternatively, jackscrew can be used passing through a hole in the centre of the plate, applied against the end of the shaft. Packing (e) to be placed between the jackscrew and shaft to prevent damage to tap holes or countersunk centering holes in shaft end. Failing removal by means of the clamp a bearing extractor should be used and it might be helpful to warm the inner bearing race slightly with a blowlamp.

Bearing Fitting

The inner clamp (a) should be put on first and then the bearing (b), A tube (c) to be placed over the shaft against the inner race, and gently to be driven on by means of hammer or mallet until the inner face is hard against the shaft shoulder (d) care should be taken to see that the shoulder is clean and free from burrs.

When the bearing is fitted, the alignment must be checked by means of a clock indicator.

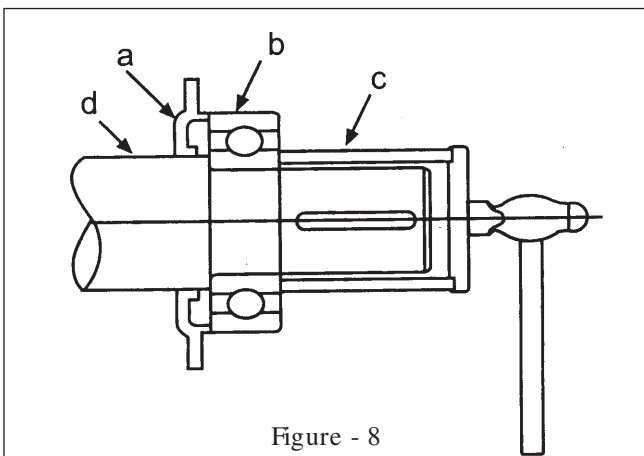

Figure - 8

Slipring Maintenance

If the sliprings have developed a smooth brown skin on their working surface, care should be taken not to interfere with the slipring in any way other than to clean away dust. The brown skin is to be left completely untouched.

Should bad flakes develop, and the rings become pitted, they should be skimmed on a lathe and made true to the bearing seating of the shaft. The ring surface should be turned and then ground or polished. All traces of metallic dust must be removed. Insulation resistance to be checked sliprings to shaft and connectors to rings, periodically.

Tightness of connection from winding to Slipring should be checked periodically.

Brushgear Maintenance

It is necessary to keep it clean and brush pressure to adjust to 0.2 Kg/ Sq. CM.

Worn out brushes should be replaced only with those of similar grade and carefully bedded to ensure good smooth contact.

Free movement of the brushes in their respective boxes, must be ensured.

To bed in brushes, wrap a sheet of coarse glass paper around the periphery of the sliprings, such that the brushes are pressing against the glass paper under their own spring pressure. Holding the glass paper firmly, rock the rotor backwards and forwards until the brushes are worn to the same contour as the sliprings. At this stage replace the coarse glass paper with a fine grade of glass paper and finish off bedding of the brushes. After bedding, blow out the brushgear with an air jet taking care not to allow carbon dust to enter the motor windings.

Excessive sparking may be caused by :

- a) The machine being overloaded excessive vibration, unequal air gaps.
- b) Brushes worn, too tight or loose in the boxes. A suitable clearance is 0.1/ 0.25 mm on short side is advisable.
- c) Brushes not bedded properly.
- d) Insufficient or unequal brush pressure.
- e) Brushes not equally spaced circumferentially.
- f) Brush rocker not in its marked position.
- g) Dirty brushgear, or sliprings.
- h) Winding faults.

Sparking may also occur, if brushes of two or more different grades are used.

Only brushes as supplied with machine should be used unless changed on the advice of MARATHON Electric. If on investigation, none of the above points effect on improvement, it may be referred back to MARATHON Electric.

Balancing

Machines are carefully balanced during manufacture, but if any unusual vibration occurs, a thorough inspection should be made to ascertain the cause. The vibration may be due, not to any want of balance of the machine itself, but to misalignment, faulty couplings, incorrect bearing clearance, distortion due to unequal heating and expansions, or winding faults.

In case of rebalancing, redistribution of the existing weights or the addition of new weights must only be done on the part to which the existing weights are attached and all weights must be fastened securely and screws locked. Before removing or altering any balance weights, the weights and their positions must be recorded so that the original setting can be restored if required. An experienced person should only do the balancing of high speed machines, hence if any out of balance is present or suspected or any advice desired on the subject, MARATHON Electric should immediately be informed.

Terminal Box

Cables should enter the terminal box through conduit or a suitable gland to prevent the entry of moisture, dust and dirt. Where gaskets are fitted to the terminal boxes they should be replaced, if broken during installation or maintenance, to ensure a continuous and tight joint.

It is necessary to ensure the security of connections. The interior of the box should be wiped with a clean lint-free cloth and vacuum-cleaned if necessary.

Reassembly

Reassembly is the reverse of dismantling procedure.

Sealant like Anaerobic Adhesive (IP55 motors) sealant is to be applied between frame and bracket spigots to give the required degree of protection.

It must be ensured that oil seals/ V seals must be refitted.

All fixing screws are to be tightened evenly making certain that no distortion of endshields occur.

On assembly, rotate the shaft by hand. If locked or stiff, loosen the cap screws or end shield screws

and retighten spinning the shaft to ensure freedom. Never tighten the screws individually and ensure that all fixing screws are evenly tightened. Before running check that the fan does not foul the housing.

5.0 TROUBLE SHOOTING

■ Failure To Start Or Accelerate

- a) Check all connections against the circuit diagram, see that there are no open circuits and that all terminals and contacts are clean and right.
- b) Check supply voltage at all the motor terminals to see if any reduction is taking place due to line drop. If on auto-transformer start is being used, select a higher tapping.
- c) Ensure that the machine is not overloaded – try to start the motor uncoupled from load.
- d) Check that any thermal, over current or over-voltage protection devices have not been tripped, and that they have been set correctly.
- e) Check that stator line currents and phase resistance is balanced and that the insulation resistance is correct.
- f) Inspect the rotor bars and endrings.
- g) In case of SR Motors, check the rotor resistance-circuit and control.
- h) If motor crawls at low speed, the motor and load torque speed curves are probably mismatched. (This is only likely to be of concern when starting STAR/ DELTA).
- i) Load inertia may be too high, thus resulting in a prolonged start-up time – consult MARATHON Electric.

■ Vibration

- a) Run the motor uncoupled to check that the load is not inducing vibration.
- b) Check the alignment between the motor and the driven equipment.
- c) Check the security of foundation bolts, base plate, bearing cartridge and stator holding-down bolts.
- d) Check bearings for excessive wear or incorrect assembly.
- e) Check that the stator line currents and phase resistance is balanced.

- f) Check the rotor bars, endrings and other rotating parts for damage.

■ Mechanical Noise

- a) Check that there is nothing rubbing or catching on the shaft or coupling.
- b) Check the lining out of the motor and driven equipment.
- c) Check for correct assembly of bearings and check grease.
- d) Measure the Stator/ Rotor air gap to ensure concentricity.
- e) Check for foreign matter in the air gap.

■ Magnetic Noise

- a) Check all connections against the circuit diagram. See that there are no open circuits and that all terminals and contacts are clean and tight.
- b) Check the value of the supply voltage at the motor terminals.
- c) Check that the stator line currents and phase resistance are balanced and that the insulation resistance is correct.
- d) Check the air gap for eccentricity.
- e) Inspect the rotor bars and endings.

■ Winding Overheating

- a) Check all connections against the circuit diagram. See that there are no open circuits and that all terminals and contacts are clean and tight.
- b) Check for the correct value of supply voltage at terminals.
- c) Check line currents and rated figure for possible overload.
- d) Measure the air inlet or ambient air temperature.
- e) Measure the stator air gap for concentricity.
- f) Check that the stator line currents and phase resistance are balanced and measure the insulation resistance.
- g) Inspect the rotor bars and endrings.
- h) Check for restricted ventilation.
- i) Check for correct starting time and duty cycle.
- j) Check for probable single phasing due to bad Stator control or blown fuse.

■ Bearing Overheating

- a) Check that the bearing is correctly greased with an approved lubricant.
- b) Check the alignment to ensure that the bearing is not being overloaded.
- c) Check that the bearing is correctly assembled – remove the bearing and check for wear.
- d) Inspect ball and roller bearings for wear or damage.

■ Brush Heating

- a) Measure and compare line current with that given on motor nameplates.
- b) Check whether brushes are not bedding or sticking in holders – carefully re-bed or clean brushes and adjust pressure, check the spring tension.
- c) Check grades of brush material – ensure grade recommended by manufacturer is being used.
- d) In case sparking of brush is noticed, polish slipping surface and apply pressure on brush.

We however, do not recommend the dismantling of machines by clients themselves during the guarantee period. In case of any trouble the matter should be immediately brought to the notice of the nearest MARATHON Electric branch.

6.0 SPARES

Spare parts are those parts, which must be replaced as a result of some accident or unusual operation.

Recommended Spares

The spares recommended to be stocked at site are

- Bearing
- Carbon Brush, Brush holder (For Slip ring motors)
- Terminal block
- External Fan and Fan Cover

Ordering Spares

When ordering for Spare Parts, the name of component and quantity required should be stated.

To minimize delay, quote details like :

Serial Number of the motor, kW, Speed, Voltage and Frame Size as given on the motor nameplate in all correspondences.

By giving this information the Spares Department can check to determine if any special features were employed in the manufacture of the motor in question.

Appendix - A

BEARING CHART FOR SQUIRREL MOTORS (HORIZONTAL FOOT MOUNTING)

TOTALLY ENCLOSED FAN COOLED TYPE

FRAME SIZE					POIE	BEARING SIZE	
NEMA	IEC					DE	NDE
	ALPOWER	CHALLENGER	KAPAK	FLAME PROOF			
	DA63				AIL	6202ZZC3	6202ZZC3
	DA71				AIL	6202ZZC3	6202ZZC3
	DA80	D80			AIL	6204ZZC3	6204ZZC3
143T, 145T	DA90	D90			AIL	6205ZZC3	6204ZZC3
				KF90	AIL	6205ZZC3	6205ZZC3
	DA100	D100			AIL	6206ZZ	6205ZZ
182T	DA112	D112			AIL	6206ZZC3	6205ZZC3
184T					AIL	6206ZZC3	6205ZZC3
				KF112	AIL	6306ZZC3	6305ZZC3
				KF132	AIL	6308ZZC3	6306ZZC3
213T	DA132	D132			AIL	6208ZZC3	6207ZZC3
215T					AIL	6208ZZ	6207ZZ
254T, 256T	DA160	D160			AIL	6309ZZC3	6209ZZC3
				KF160	AIL	6309ZZC3	6309ZZC3
284T/TS, 286T/TS	DA180	D180			AIL	6310ZC3	6210ZC3
				KF180	AIL	6310ZC3	6310ZC3
				KF200	2	6312C3	6312C3
				KF200	4-10	N312C3	6312C3
326T/TS		D200			AIL	6312C3	6310ZZC3
364T/TS		D225			AIL	6313C3	6313C3
365T/TS					AIL	6313	6313
				KF225	2	6313C3	6311C3
				KF225	4-10	N313C3	6311C3
405T/TS		D250			AIL	6314C3	6313C3
				KF250	2	6315C3	6313C3
				KF250	4-10	N315C3	6313C3
		D280			AIL	6317C3	6314C3
444TS					2	NU218	6314
445TS					2	NU218	6314
				KF280	2	6317C3	6317C3
				KF280	4-10	N317C3	6317C3
444T					4-10	NU318	6314
445T					4-10	NU318	6314
		D315S/ M			2	6317C3	6316C3
504T		D315S/ M			4-10	6319C3	6318C3
		D315M/ L			2	6317C3	6217C3
505T		D315M/ L			4-10	6319C3	6319C3
				KF315M	2	N217C3	6316C3
				KF315M	4-10	N319C3	6316C3
		D355	K355	KF355	2	N317C3	6317C3
		D355	K355	KF355	4-10	N321C3	6321C3
			K400		4-10	NU324	6324
			K450		4-10	NU324	6324

PROTECTED TYPE

FRAME SIZE		POIE	BEARING SIZE	
INTERNATIONALFRAME	CONVENTIONALFRAME		DE	NDE
C160		AIL	6310ZZC3	6309ZZC3
C180		AIL	6312C3	6311C3
C200		AIL	6313C3	6312C3
C225		AIL	6314C3	6313C3
C250		AIL	NU316C3	6314C3
C280		AIL	NU317C3	6315C3
C315		4 - 10	NU319C3	6317C3
	RS78	4 - 10	NU 317	6315
	RS89	4 - 10	NU 320	6317
	RS105	4 - 10	NU 224	6320
	RS120	4 - 10	NU 224	6320
	RS136	4 - 10	NU224	6320
	RS152	4 - 10	NU326	NU224 & 6224
	RS168L	4 - 10	NU326	NU224 & 6224

BEARING SCHEME FOR HOLLOW SHAFT MOTOR

Four-point contact ball bearings, designated as 'QJ' are single row angular contact ball bearings, desinged to enable axial loads to be accommodated in both directions.

SL NO.	FRAME SIZE	POIE	BEARING SCHEME (FLANGE END / RATCHET END)
1	CVH180	4P	6311 C3 / QJ316 N2
2	CVH200	4P	6311 C3 / QJ316 N2
3	CVH225	4P	6311 C3 / QJ 316 N2
4	CVH250	4P	6315 C3 / QJ320 N2
4	CVH280	4P	6315 C3 / QJ320 N2
5	CVH315	4P	6320 C3 / QJ 326 N2

Appendix - A

BEARING CHART FOR SLIPRING MOTORS (HORIZONTAL FOOT MOUNTING)

TOTALLY ENCLOSED FAN COOLED TYPE

FRAME SIZE	POLE	BEARING SIZE	
		DE	NDE
KS112	4	6306ZZ C3	6305ZZ C3
KS132	4	6308ZZ C3	6308ZZ C3
KS160	4	6309ZZ C3	6309ZZ C3
KS180	4	6310 C3	6310 C3
KS200	4	NU312 C3	6312 C3
KS225	4	NU314 C3	6314 C3
KS250	4	NU315 C3	6315 C3
KS280 / KSE280	4	NU317 C3	6317 C3
KS315 / KSE315	4	NU319 C3	6319 C3
KS355 / KSE355	4	NU321 C3	6321 C3
KS400	4	NU324	6324
KS450	4	NU324	6324
KS500	4	NU326	6326
KS560	4	NU332	6332

TOTALLY ENCLOSED TYPE

FRAME SIZE	POLE	BEARING SIZE	
		DE	NDE
MZ35	4	6306ZZ C3	6306ZZ C3
MZ41	4	6308ZZ C3	6308ZZ C3
MZ48	4	6308ZZ C3	6308ZZ C3
MZ56	4	6310ZZ C3	6309ZZ C3
MZ63	4	6311 C3	6310ZZ C3

PROTECTED TYPE

FRAME SIZE			POLE	BEARING SIZE	
INT. TYPE	CONV. TYPE	CONV. TYPE		DE	NDE
CW160			AIL	6310ZZ C3	6309ZZ C3
CW180			AIL	6312 C3	6311ZZ C3
	AW138		AIL	6312 C3	6312
	AW139		AIL	6312 C3	6312
	AW140		AIL	6312 C3	6312
CW200			AIL	6313 C3	6312 C3
	AW145		AIL	NU313	6312
	AW146		AIL	NU313	6312
CW225			AIL	6314 C3	6313 C3
	AW150		AIL	317	6313
	AW150		AIL	317	6313
	AW151/1		AIL	317	6313
CW250			AIL	316 C3	6314 C3
CW280		RW78	AIL	317 C3	6315 C3
CW315			AIL	319 C3	6317 C3
		RW89	AIL	NU320	6317
		RW105	AIL	NU224	6320
		RW120	AIL	NU224	6320
		RW136	AIL	NU224	6320
		RW152	AIL	NU326	NU224 & 6224
		RW168L	AIL	NU326	NU224 & 6224
		RW168 100-112	AIL	NU332	6332

Appendix - B

APPROXIMATE RELUBRICATION INTERVALS FOR BEARINGS OF MOTORS
(HORIZONTAL FOOT MOUNTING)

BEARING SIZE	APPROXIMATE RELUBRICATION INTERVAL (HOURS)				
	2 POLE	4 POLE	6 POLE	8 POLE	10 POLE
6202ZZ	<p style="text-align: center;">BEARINGS ARE SEALED FOR LIFE RELUBRICATION IS NOT REQUIRED RELUBRICATION FACILITY IS NOT PROVIDED</p>				
6204ZZ					
6205ZZ					
6305ZZ					
6206ZZ					
6306ZZ					
6208ZZ					
6308ZZ					
6309ZZ					
6310ZZ					
6310	4300	9500	18000	24400	31000
6311	2700	6500	12100	16400	20800
6312	1800	4300	8000	11000	14000
6313	1700	4100	7800	10400	13400
6314	1500	3900	7500	10000	13000
6315	1450	3700	6600	9300	12000
6316	1400	3600	6200	8900	11400
6217	1680	4200	7000	9900	12000
6317	1380	3500	5900	8400	11000
6319	1200	3200	5300	7700	10000
6320	1170	3160	5000	7200	9000
6321		3000	4800	7000	9300
6224		3360	5700	7200	9000
6324		2800	4000	6100	8200
6326		2650	3700	5500	7100
6332		2260	3200	5200	6900
NU312	1800	4300	8000	11000	14000
NU313	1700	4100	7800	10400	13400
NU314	1500	3900	7500	10000	13000
NU315	1450	3700	6600	9300	12000
NU316	1400	3600	6200	8900	11400
NU217	1680	4200	7000	9900	12000
NU317	1380	3500	5900	8400	11000
NU319	1200	3200	5300	7700	10000
NU320	1170	3160	5000	7200	9000
NU321		3000	4800	7000	9300
NU224		3360	5700	7200	9000
NU324		2800	4000	6100	8200
NU326		2650	3700	5500	7100
NU332		2260	3200	5200	6900

Appendix - C

DIMENSIONAL DETAILS OF CARBON BRUSHES FOR SLIPRING MOTORS

TOTALLY ENCLOSED FAN COOLED TYPE

Frame Size	LENGTH 'L' mm	BREADTH 'B' mm	WIDTH 'W' mm	No. of Brushes
KS112	25.5	19.0	9.5	6
KS132	25.4	19.1	9.5	6
KS160	25.4	19.1	9.5	6
KS180	31.8	25.4	9.5	6
KS200	31.8	31.8	15.9	6
KS225	31.8	31.8	15.9	6
KS250	31.8	31.8	15.9	6
KS280	35.6	31.8	22.2	6
KSE280	31.8	31.8	15.9	6
KS315	35.6	31.8	22.2	6
KSE315	31.8	31.8	15.9	6
KS355	35.6	31.8	22.2	12 or 6
KSE355	31.8	31.8	15.9	12
KS400	44.5	38.1	31.8	12
KS450	44.5	38.1	31.8	12
KS500	44.5	38.1	31.8	12
KS560	44.5	38.1	31.8	18

TOTALLY ENCLOSED TYPE

Frame Size	LENGTH 'L' mm	BREADTH 'B' mm	WIDTH 'W' mm	No. of Brushes
MZ35	25.5	19.0	9.5	6
MZ41	25.5	19.0	9.5	6
MZ48	25.5	19.0	9.5	6
MZ56	32.0	25.0	9.5	6
MZ63	32.0	25.0	9.5	6

PROTECTED TYPE

Frame Size	LENGTH 'L' mm	BREADTH 'B' mm	WIDTH 'W' mm	No. of Brushes
CW180	25.5	19.0	9.5	6
CW200	20.0	20.0	16.0	6
CW225	20.0	20.0	16.0	6
CW250	20.0	25.0	20.0	6
CW280	35.0	32.0	20.0	6
CW315	35.0	32.0	20.0	12
AW138	20.0	20.0	16.0	6
AW139	20.0	20.0	16.0	6
AW140	20.0	20.0	16.0	6
AW145	20.0	20.0	16.0	6
AW146	20.0	20.0	16.0	6
AW150	20.0	20.0	16.0	6
AW151	20.0	20.0	16.0	6
RW78	31.8	31.8	15.9	6
RW89	31.8	31.8	15.9	6
RW105	31.8	31.8	15.9	6
RW120	31.8	31.8	15.9	12
RW136	31.8	31.8	15.9	12
RW152	44.5	38.1	31.8	12
RW168	44.5	38.1	31.8	12



Specialized custom built motors • Specialists in short cycle deliveries

Marathon Electric Motors (India) Ltd. Registered & Head Office: 58, Taratala Road, Kolkata - 700024. IT Motor & Fan Factory, Paharpur Works, 58, Taratala Road, Kolkata - 700024, Tl: 2469 5369 / 8530, ~~09331059516~~, Large IT Motor & HT Motor Factory, AEI Works 1, Taratala Road, Kolkata-700024. **Marathon Regional Offices:** **New Delhi:** 708, Eros Building, 56, Nehru Place; Tl: 011 4160 7123, 09313290402. **Chandigarh:** Chamber No. 8a, 2 Floor, Sco No. 2441-42, Sector 22-C; Tl: 09316102451. **Mumbai:** 114 Navneelam, R.G. Thadani Marg, Worli; Tl: 022 3265 9844, 09322645753, Fax: 022 3040 1555. **Pune:** 41/14, Office Club Swaroop Complex Karve Road; Tl: 020 2546 3978, 09371025388. **Ahmedabad:** 415 / Platinum Plaza, Nr. Pushkar Tower, Judge-bungalow-bodakdev Road; Tl: 079 2560 2297, 09327048567. **Nagpur:** 1 Floor, Block A, Thapar Enclave, Plot No. 148, Ramdaspath; Tl: 0712 2526 220, 09373283527. **Rajpur:** 1 Floor, 141, Sundernagar, Near Adarsh Chowk; Tl: 0771 2210 240. 09329128913. **Chennai:** Door No. 9, Flat No. 7, 1 Floor, Thiru. Vi. Ka. Road, Royapettah, (opp, Sathyam Theatre), Tl: 044 4351 0152, 09382102392, Fax: 044 4351 0153. **Secunderabad:** Cabin No. 47, 303, Swapnalok Complex, 92, S. D. Road; Tl: 040 2781 2724, 09391340619. **Bangalore:** C1-101, White House, 15 Cross, 6 Main R. T. Nagar; Tl: 080 2655 8729, 09341279429. **Bhubaneswar:** C/ o. Plot No. 16-b, Engineers Colony, Old Station Bazar; Tl: 0674 231 3744, 09338212907. **Jamsbedpur:** C/ o. Mr. D. P. Ghosh, House No. 7, Bidyasagar Path, Uliyan, Kadma; Tl: 0 93346 12014. **GEMI Motors India Pvt. Ltd.,** Sec.-11 Model Town, Faridabad - 121006 (INDIA), Tl: 0129 2286421/2265340; Fax : 0129-2284855, email : gemi.sales@regalbeloit.com **GEMI Regional Offices :** **Ahmedbad :** 406, Vedant Complex, 7, Kalpana Colony, Off. C.G. Road, Navrangpura, Ahmedabad-380009, Tl: 079-26561819, 9825611502. Fax: 079-26560452. **Chennai :** 6 Arcot Road, Vadapalani, Chennai - 600092, Tl: 044-42136697, 42333353, 9840429331, Fax: 044-42082322. **Jaipur :** C/ o Flat No. 104, Block A, Rama Heritage Apartments, Central Spine, Vidhyadhar Nagar, Jaipur-302 023. Ph: 9982655661. **Kolkata :** 58, Taratala Road, Kolkata - 700024; Tl: 91 033 24695560/ 61, Fax: 033 24695369/8530. **Mumbai :** B-908/909, Sagar Tech Plaza, Andheri - Kurla Road, Saki Naka, Andheri (East), Mumbai - 400072, Tl: 022-28523106, 9833756269, Fax: 022-28528938. **Pune :** C/ o: 8, Sethu Apartments, Right Bhusari Colony, Paud Road, Kothrud, Pune-411038, Tl: 020-65224846, 9960604846. **Bangalore :** Tl:9342299995. **Hyderabad :** Tl:9393002665. **Delhi :** Flat No. 516-518, 5th Floor, Antriksh Bhawan, 22 K.G. Marg New Delhi -01 Tl: 9873184209.