

Operating functions



09

POWER GUIDE 2009 / BOOK 09

INTRO

Irrespective of the requirement for continuity of service, operation and maintenance work on installations must be carried out in maximum safety. They must be performed in accordance with strict protocols to ensure everyone's safety: those carrying out the work and others. This work requires special isolation, locking, separation (forms) and signalling devices, which are added to the basic breaking and protection functions.

Safety standards and regulations govern this field under the generic term "safety requirements". In addition, breaking devices for emergencies are generally required by specific texts: safety of workers, public buildings, etc. In modern installations, additional provisions and methods are necessary to meet the ever-increasing requirements for reliability, continuity of service, adaptability, safety and management of energy sources. Standard operational actions: switching on/off, changing power supply, measurements, resetting, are more and more often centralised or automated. For this, auxiliaries are used for remote control (coils, motor-driven controls, etc.) and for feeding back information on the status of devices.

Locking out structures and equipment

Lockout operations	03
1. Separation	03
2. Immobilisation	04
3. Dissipation (or setting to the lowest energy level)	04
4. Checking	04
5. Signalling	04
6. Identification	04
Definitions (usual terms)	05
1. Structures	05
2. Operational actions	05
3. Training and qualification	07
4. Accreditations	07
5. Authorisations	08
6. Immobilisation	08
7. Locking	08
Standard diagrams with locking procedures	09
Work on equipment	12
1. Fixed devices	12
2. Plug in devices	12
3. Draw-out devices	12
4. Busbars	13

Physical accessibility and protection provisions

Separation forms	14
1. Form 1	15
2. Forms 2a and 2b	15
3. Forms 3a and 3b	16
4. Forms 4a and 4b	17
5. Determining forms with XL PRO ² software	18

Motorisation and supply inversion

Motor-driven control	20
Supply inverters	21
Control units	22

Emergency breaking and stops, isolation

Emergency breaking	24
The emergency stop	28
Isolation	30
1. Isolation with permanent contact indication	30
2. Isolation with visible contact indication	31

Choice of products

DMX ³ ACBs and DMX ³ -I trip-free switches	32
DMX-E air circuit breakers	34
DPX circuit breakers and DPX-I trip-free switches	36
DRX circuit breakers	40
DPX-IS and Vistop isolating switches	41
XL ³ 4000 forms	42

Locking out structures and equipment

Isolation, switching, checking, testing and maintenance are all operations that must be carried out and planned with great care, in order to maintain the safety of people and property. To this end, a number of duly identified and organised actions are necessary. Together they constitute locking out.

To ensure continuity of operation and even safety, the lockout operations must as far as possible be restricted to limited parts of the installation. It is therefore necessary to have full knowledge of the entire operation of the installation before locking

out part of that installation. This applies to industrial processes, and also commercial installations (for example, data centers) especially when there are several power supplies.

Example of a power supply layout for a data centre

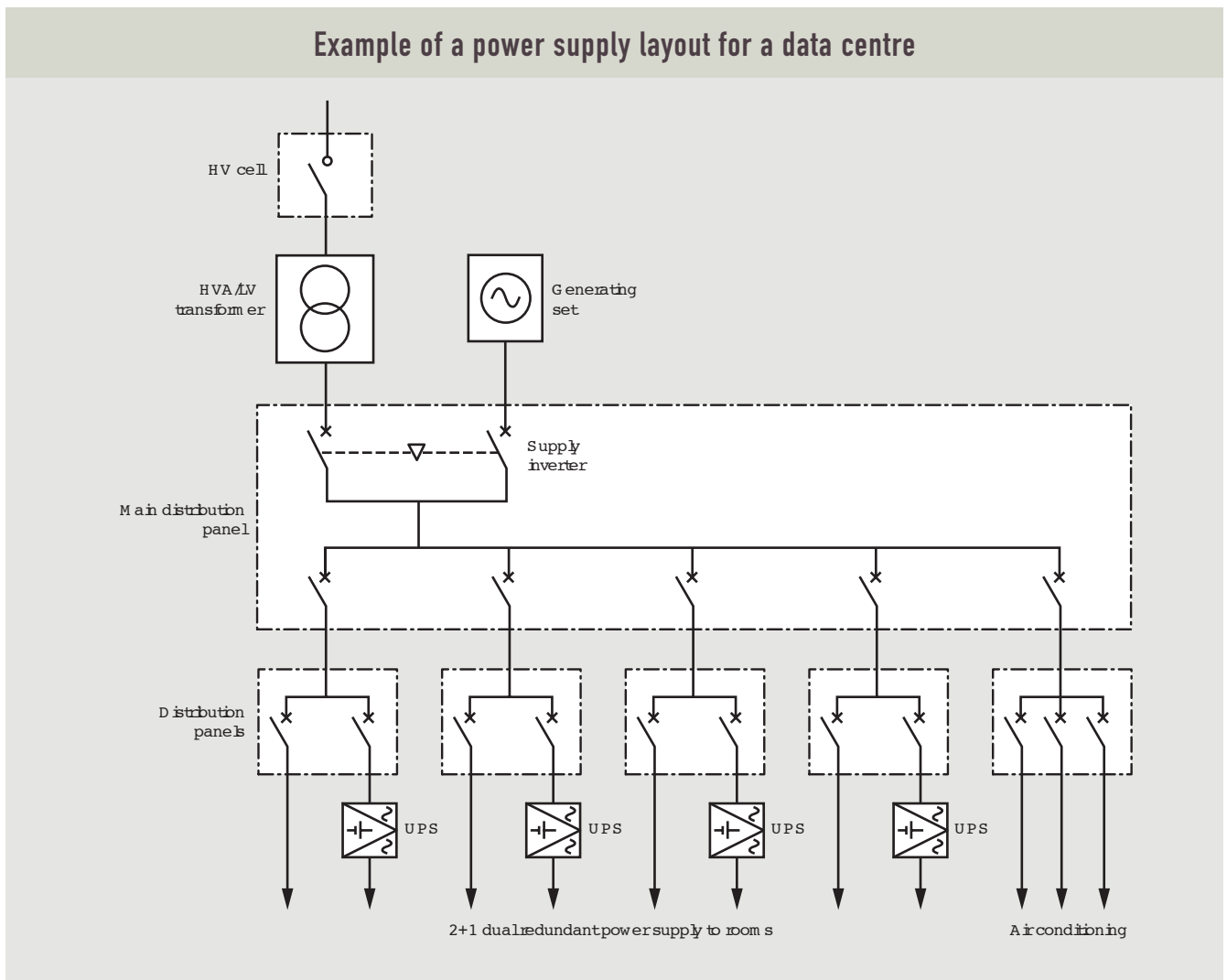

LOCKOUT OPERATIONS

The “lockout” or “safety procedure” is a precise, clearly-defined operation, the aim of which is always to ensure that situations are, and remain, safe. This will enable people to work on all or part of an installation (or a device), with return to operation (removal of lockout) only being possible by the intentional, concerted action of those responsible. Lockout consists of a number of essential steps:

separation, immobilisation, dissipation, checking, signalling and identification.

1 SEPARATION

This consists of “de-energising” all power, control and monitoring, and emergency circuits by breaking with visible or positive contact indication.

Head-end breaking

Head-end breaking can be carried out by an isolating switch or an isolating switch with visible contact indication (Vistop, DPX-IS) or by a device which has both adequate clearances and reliable control between the position of the contacts and that of the operating device (DPX).

This condition can be met by using a DPX or DMX type draw-out device or by combining an isolating switch with a DPX circuit breaker.

■ Positive contact indication



Positive contact indication ensures there is a permanent mechanical link between the contacts and the operating handle. The position of the operating handle indicates the actual position of the contacts. It cannot be set to OFF if the contacts are soldered

■ Visible contact indication



The Vistop and the DPX-IS provide isolation with visible contact indication. The operating handle can have up to 3 lockout padlocks

Locking out structures and equipment (continued)

2 IMMOBILISATION

This is carried out by mechanical means using padlocks or locks. It prevents any intentional or accidental operation of the immobilised device. It should be noted that profiled keys (triangle, square, etc.) are not permitted for this function.



^ Immobilisation of a DPX 630 with padlocking accessory and padlock

3 DISSIPATION (OR SETTING TO THE LOWEST ENERGY LEVEL)

This consists of discharging the capacitors. For maximum safety, it includes the earthing and short-circuiting of the conductors. It is compulsory above 500 V, but is not compulsory below this level (LV range) unless there is a risk of induced voltages, capacitive effects (capacitors or considerable lengths) or a risk of backfeed.

4 CHECKING

This must be carried out as close as possible to the location of the operation, with a standard device for "detecting the absence of voltage" (EN 61243-5) between all the conductors including the neutral and between those conductors and earth. Multimeter or tester type checking devices are expressly prohibited. These first four systematic steps must be accompanied by the means required for informing people "not working and working" on the equipment.

5 SIGNALLING

This consists of clear, precise and permanent information on the lockout status of the installation. It may be necessary to mark out the area.



It should be noted that in the LV range (< 500 V), it is possible to affix a sign prohibiting operation of the separation device in exceptional circumstances if the device has no means of immobilisation. This practice must not be permitted if the device cannot be seen from where it is operated.

6 IDENTIFICATION

This must enable targeted work, with no ambiguity, to be carried out on the device or part of the installation concerned. To this end, up to date wiring diagrams, geographical location maps, markings, etc., must be available.



DEFINITIONS (USUAL TERMS)

1 STRUCTURES

Although the general principles remain the same for all lockout operations, the measures to be taken may differ depending on the scope concerned: network, installations, devices and equipment.

1.1. Distribution networks

This concerns the part of the structures that is the responsibility of the energy distribution company. Rules (for example, EDF specifications), which are subject to specific decrees, are applicable to these networks.

1.2. Electrical installations

These consist of all the equipment involved in the transformation, transport, distribution and provision of energy.

The main LV distribution board is part of the installation.

Standard IEC 60364-1 establishes harmonised international rules for the design, setup and checking of electrical installations. These rules are designed to ensure the safety of people, animals and property with regard to the hazards and damage that may occur during reasonable use of electrical installations and to ensure correct operation of these installations. Standard IEC 60364-1 applies to the design, setup and checking of electrical installations such as those in: residential buildings, commercial buildings, public buildings, industrial establishments, agricultural and horticultural establishments, prefabricated buildings, caravans, campsites and similar installations, construction sites, funfairs, fairs, exhibitions and other temporary installations, marinas, external lighting and similar installations, medical premises, mobile or transportable units, photovoltaic systems, low voltage generating sets.

Numerous national standards or regulations are often added to these basic rules. In France, for example, these may include the decree of 14 November 1988

on the protection of workers in premises where electricity is used, the Safety Regulations for Public Buildings and various standards said to be for installations: NFC 13-100 (supply stations), NFC 13-200 (high voltage installations), NFC 14-100 (Connection installations), etc.

1.3. Devices and equipment

These consist of busbar systems and accessories. Secondary distribution boards and terminal boards containing controls and protection are included in devices and equipment. There are many applicable standards, specific to each item of equipment or family of devices: the EN 60439, EN 60204, EN 60947, etc. series of standards.

2 OPERATIONAL ACTIONS

Operational actions are intended for standard operations: switch on/off, connections for this purpose, measurements, resetting that can be carried out without any particular risk in the context of normal operation.



^ DMX³ 2500:
draw-out version

Locking out structures and equipment (continued)

These must not be confused with emergency operations, which arise from the need to provide optimum protection of people and property within the context of dangerous circumstances. Operational actions require basic safety precautions, taking care in particular to use personal protection devices (insulated gloves), measuring devices and appropriate test plugs, insulated pliers, etc.

The risk of short-circuits must be minimised in view of their consequences.

In principle, the steps must be taken after first carrying out an analysis which includes:

- The type of work (measurements, testing,

connection, cleaning, etc.)

- The general environmental conditions, in particular the atmospheric conditions (precipitation or risk of storms)

- The actual conditions of inaccessibility to unqualified people or possibility of contact with the earth potential

- The requirements specific to "live working" which are divided into: "insulated glove working", "safe clearance working" or "bare hand working". These are in all cases subject to specific accreditation granted by the head of the establishment. Carrying out live work is subject to the appropriate procedures and requires special protection equipment and tools.



Titles of those involved according to standards

Standard EN 50110-1 has laid the foundations of European harmonisation aimed at gradual alignment of the safety levels associated with the operation of, and work on or near installations. These minimum specifications can be supplemented by additional national requirements. In France, the collection of general electrical safety instructions UTE C 18-510 constitutes the main reference document in the field. Its presentation in the form of a booklet is aimed at making it a real everyday tool. The following definitions concerning people are taken from this book. Those marked (EN) are also used by standard EN 50110-1.

■ Employer

Person who, directly or indirectly, assumes legal responsibility in the context of the Labour Regulations. To avoid any confusion between the company which is the ordering customer and the company carrying out the work, the term head of the establishment or operator can be used for the former and company manager for the latter.

■ Operation supervisor (EN)

Person designated by the employer to carry out the operation of an electrical structure, including the performance of work and interventions.

■ Electrical lockout supervisor

Person designated by the employer or the operation supervisor to carry out all or part of the lockout and to ensure appropriate safety measures are taken.

■ Requisition supervisor

Person designated by the operation manager, responsible

for requisitioning all or part of structures, mainly networks or installations spread over wide areas. For the requisitioned part, he/she may then perform the role of lockout supervisor.

■ Works supervisor (EN)

Person who manages work. Responsible for taking, or ensuring others take, safety measures, and ensuring they are implemented. This person may work on his/her own, or be involved in the work he/she manages.

■ Test supervisor

Person who manages tests. He/she is responsible for taking the necessary measures and ensuring they are implemented.

■ Operative

Person designated by his/her employer to carry out work in accordance with a verbal or written instruction. He/she must have the appropriate qualification for the work to be performed.

■ Electrical safety supervisor

Safety specialist made responsible by his/her employer for monitoring the safety of people working on or in the vicinity of the electrical structures.

■ Qualified person (EN)

Person with the appropriate knowledge for carrying out the tasks assigned to him/her.

■ General foreman

Person carrying out on-site management of non-electrical work in the installation. If he/she carries out electrical work, he/she is called the works supervisor.

3 TRAINING AND QUALIFICATION

A special theoretical and practical training programme, representative of the work to be carried out, must be drawn up to develop and maintain the ability of qualified or well-informed people to carry out electrical work and in particular live work. At the end of the training, the participant must be awarded a certificate. The aptitude level is validated by accreditation which must be renewed if the person changes job or line manager, has a long break from work, medical restrictions, clear lack of aptitude, or if there are significant changes to work methods or installations.

4 ACCREDITATIONS

Accreditation consists of the recognition by the employer of a person's aptitude to perform the tasks assigned to him/her totally safely. A written certificate of accreditation, including the identification and approval of the parties and the code of the level of accreditation, must be given to the employee. This certificate does not however release the employer from his/her responsibilities. The accreditation level must be appropriate to the work to be carried out: it will be different for example for the painter who is working in a transformer room and the electrician working on the transformer itself. But it is essential that they have both received training appropriate to the risks incurred to themselves and to others.



Accreditation code

UTE guide C 18-510 defines a code that is widely used in France and several European countries

- **First letter:**
 - B for the LV or ELV range
 - H for the HV range
- **Second letter (optional):**
 - R for repair, connection, testing or measurement work (LV only)
 - C for the ability to perform lockouts
 - T for live working
 - N for carrying out cleaning work while live
 - V for working in the vicinity of live parts
- **Number:**
 - 0 for staff not carrying out electrical work
 - 1 for staff carrying out electrical work
 - 2 for electrical works supervisor who can manage several people
- **Some (non-limiting) examples of common accreditations in the LV range:**
 - B0: Non-electrician who can access reserved areas
 - B1: Electrician working under instruction
 - BR: Works supervisor managing work he/she carries out and its safety
 - BC: Person responsible for the lockout.





Accreditation is obviously necessary for carrying out electrical work, but it is also required for managing this work, for monitoring, for locking out an installation, for carrying out tests and taking measurements, and of course simply for unsupervised access to an area reserved for electricians. For example, the person who carries out the cleaning on a test platform must be accredited accordingly.



Locking out structures and equipment (continued)

5 AUTHORISATIONS

Whatever work is undertaken, the lockout operation itself must form the subject of written documents and above all confirmation that these documents have been safely received by the addressee. Messages sent electronically (faxes, emails) must be subject to appropriate precautions regarding the guarantee of receipt and their being understood. A reply message with the identification number of the original message is compulsory. The read receipt is not sufficient. The lockout certificate will be used for this purpose. It must be sent to the works supervisor, marked with the date and time, and must incorporate a section for notification of the end of work. Other documents may be used. The list given here is not exhaustive: work order, operation sheet, instruction, notice of requisition, certificate of separation from the public distribution network, etc. For further details, please refer to the statutory texts currently in force.

6 IMMOBILISATION

The purpose of immobilisation is to prevent the operation of the separation device. It must include the mechanical immobilisation of the device and the disabling of all controls, whether these are electrical, electronic, radio, etc. In addition an indication (display, indicator, etc.) must clearly signal the immobilised state.



^ Draw-out DPX 630 immobilised using padlocks



< Adaptable locking unit on draw-out DPX 630

7 LOCKING

Only locking can ensure the immobilised state. Several locks are often used together:

- To order the sequence of operations (order of commands)
- To make the operations interdependent and alternative (for example, supply inversion)
- To necessitate the simultaneous action of several people (increased safety).

Locking is carried out taking into account the safety of people and property, for example: prevention of access to HV cells before they are de-energised, prevention of the opening or closing of an isolating switch which is on-load, etc.

When the key is released by the first lock and thus allows a second lock to be operated, this is referred to as interlocking with key transfer.

The locking sequence may also require the release of several keys: in this case a device with multiple locks enables the first key, referred to as the "mother key", which must remain captive, to release several keys, referred to as daughter keys.



The basic locking principle is based on the uniqueness of the key. One key may operate one or more locks, but it must never be possible for one lock to be operated by two identical keys.

STANDARD DIAGRAMS WITH LOCKING PROCEDURES

In all cases the choice of locks and safety positions requires prior analysis of the locking sequence to be applied in order to correctly define the requirement and clearly identify the related risks. "Electric" locking systems are never considered to be adequate. In principle, only "mechanical" locking systems are capable of ensuring safety (as long as they themselves are reliable). There are various possible graphic representations of locking mechanisms. Some representations give the status of the lock (bolt pushed in or not pushed in) and the key (not captive or captive). Diagrammatic symbols are also used, but it is advisable to explain complex sequences in words.

Example of diagrammatic symbols (source APAVE-France)	
Lock mechanism assembly	
Lock with key never captive	
Lock with key always captive	
Lock with key captive device closed	
Lock with key captive device open	

Functional symbols			
Mechanical locking		Keys head-to-tail	
Lock mechanism assembly		Key not in lock/bolt pushed in free operation	
Key captive		Key not in lock/bolt not pushed in operation blocked	
Key not in lock		Key not captive/bolt pushed in free operation	
Key not captive		Key not captive/bolt not pushed in operation blocked	
Key operation - insertion - extraction		Key captive/bolt pushed in free operation	
Lock on door		Key captive/bolt not pushed in operation blocked	

Locking out structures and equipment (continued)

Example 1: Locking between earthing switch, HV switch and cell door

Locking sequence:

- Opening of switch I
- The key is released
- Transfer of key A to isolating switch S
- Closing of isolating switch S
- Key B is released
- Opening of the cell door with key B
- Key B remains captive

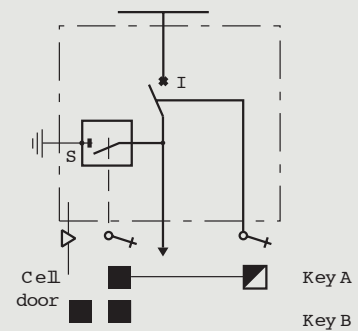

Example 2: Locking cells on HV loop system

The purpose of this procedure is to prevent the earthing switches closing when the cell is supplied upstream or downstream (loop-back).

Installation:

NB: switches I and isolating switches T are designed to be mechanically controlled.

Immobilisation sequence:

- Opening of switch I₁
- Immobilisation of switch I₁ and release of key A
- Opening of switch I₂
- Immobilisation of switch I₂ and release of key B
- Unlocking of earthing switch T₂ with key A
- Closing of earthing switch T₂
- Key A is captive
- Unlocking of earthing switch T₁ with key B
- Closing of earthing switch T₁
- Key B is captive

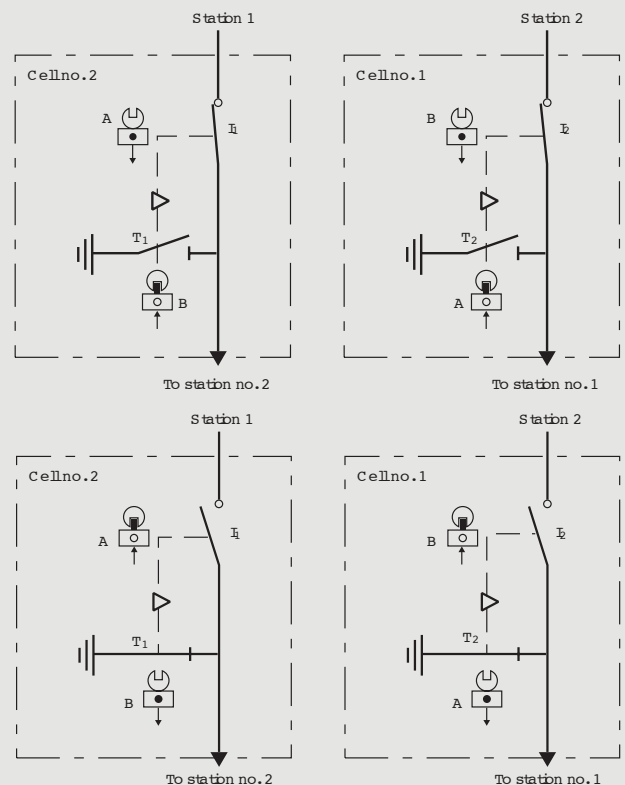

Example 3: Locking on supply inversion and on HV station

The draw-out circuit breaker is fitted with two locks.
 In normal operation, the circuit breaker I is closed, and keys A and B are captive.
 Opening the circuit breaker releases keys A and B. Key A is transferred to the HV cell upstream (see example 2).
 Key B is transferred to the standby supply (see example 4).
 Locking between the standby supply (circuit breaker G) and the HV cell may also be specified (second lock).

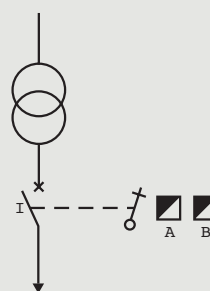

Example 4: HV/TR/LV locking (functional symbols)

Used in supply stations with LV metering, this sequence, which is one of the most common, is used to access the terminals of the transformer after:

- Opening and locking of the LV circuit breaker
- Opening and locking of the HV cell
- Earthing of the separate HV supply

Service state:

- The LV circuit breaker is closed
- Key O is captive
- The HV cell is closed
- Key S is captive
- The transformer terminals are not accessible

Locking sequence:

- Opening and drawing out of the LV circuit breaker
- Key O is released
- Transfer of key O to the lock on the HV cell
- Opening of the HV switch and closing of the earthing switch by mechanical control. Operation is possible by key transfer, as in example 1
- Key O becomes captive
- The cell panel can be opened
- Key S can be removed
- Unlocking of the immobilisation cover of the plug-in terminals
- Key S becomes captive

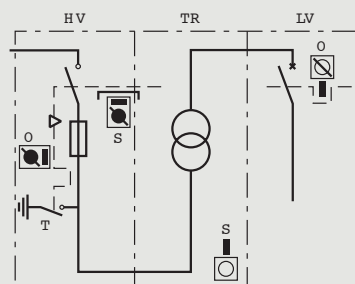
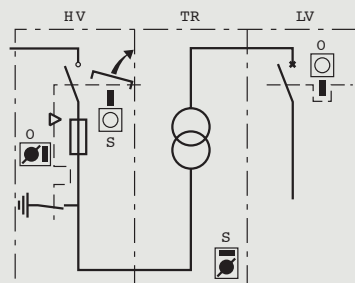
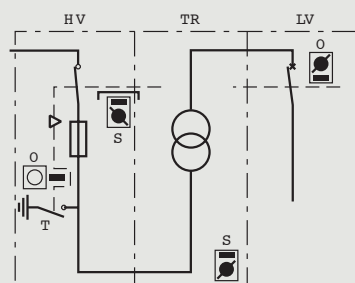

Locking out structures and equipment (continued)

Example 5: Locking on LV supply inversion

A standby power supply must only be coupled on an installation when it is certain that the main power supply is disconnected. Likewise, when devices cannot be installed side by side (supply inverter plate with integrated interlocking mechanism) or they are different types (for example, lower protected power), interlocking by key must be provided.

In normal operation: supply via transformer. Circuit breaker I is closed. Key A is captive.

In standby operation: circuit breaker I is open. The associated lock is unlocked and key A is released.

Key A is transferred to the lock on circuit breaker G, which is closed. Key A is captive.

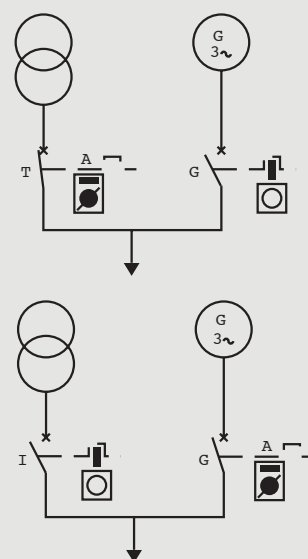

WORK ON EQUIPMENT

Power circuit breakers (devices designed to provide breaking and protection) are generally referred to using three terms: fixed, plug-in and draw-out.

1 FIXED DEVICES

Their connections can only be made or broken when their power supply is off (for example, connections on terminals or connectors). In general, it takes a certain time to fit and remove them and require a minimum number of tools. These devices are designated by the letter F ("Fixed parts"). They require an appropriate lockout upstream.

2 PLUG IN DEVICES

Plug-in (or disconnectable) devices can be inserted or removed without powering down the relevant circuit. Connection and disconnection are only possible when the device is open. Otherwise, disconnection causes mechanical breaking of the device.

Plug-in devices can, in simple situations, be used for isolation and making safe, but they are primarily used for their interchangeability, which makes maintenance much easier. They are designated by the letter D ("Disconnectable parts").

In general they do not require locking out of the installation.

3 DRAW-OUT DEVICES

In addition to the advantages of plug-in devices (interchangeability and isolation with visible contact indication), draw-out devices can be used, due to an associated mechanism, to control connection and disconnection, to enable testing and measurements while maintaining the continuity of the auxiliary circuits and breaking the main circuits, to display the status of these circuits, and by means of various systems (padlocks, locks, etc.) to lock the device for lockout operations.

Draw-out devices can be designated by the letter W ("Withdrawable parts"). Plug-in or draw-out DPX and draw-out DMX³ allow safe (IP 2x) and separate work on each circuit. DPX pre-equipped bases can take devices at a later date in the context of a scheduled extension. As long as the device is not open, a safety system prevents any removal of the faceplate.

4 BUSBARS

Work on busbars almost always requires the upstream locking out of their power supply. The use of a minimum separation form (form 2) provides protection against accidental contact if working in the vicinity. Forms 3 and 4 combined with plug-in or draw-out devices provide solutions that allow individual safe access to the various outgoing lines, without the need for total lockout of the installation.

States of the circuits for different positions of draw-out DPX

Circuits	Connected position	Test position	Isolation position	Drawn out position
Main		⌋	○	○
Auxiliary			○	○

Connected: | Open: ⌋ Isolated: ○



< DPX 250 plug-in version, mounted on its base with rear terminals

DPX 1600 > draw-out



Physical accessibility and protection provisions

The main objective is to maintain the availability of the power supply while allowing safe working (protection index xxB) and limiting the effects of any internal fault in the panel (arcs, electrodynamic forces, disconnection, etc.)

SEPARATION FORMS

Forms are used to provide a gradual, appropriate response to the accessibility and protection of the main components of a power distribution panel: busbars and breaking and protection devices (functional units).

The type of form chosen will be determined according to the qualification of those involved, the protection required and the required level of maintainability. The use of forms enables the panel to be divided into closed protected spaces in order to achieve four objectives:

- Protection against direct contact with dangerous parts of neighbouring functional units (the degree of protection must be at least IP xxB).

- Protection against the entry of solid objects. The degree of protection must be at least IP2x (degree IP 2x covers IP xxB). These two requirements assume that the assembly is equipped with faceplates.

- Limitation of the effects of the spread of electric arcs.

- Facilitation of panel maintenance operations.

Standard EN 60439-1 defines the internal separation of assemblies into 7 types of form (1, 2a, 2b, 3a, 3b, 4a and 4b).

This internal separation is achieved in XL³ 4000 enclosures using barriers or screens made of metal or insulating material.

XL³ 4000 enclosures and their accessories can be used to create all types of form.



Separation used to create forms limits the natural ventilation of the panel and can therefore result in rises in temperature. It will inevitably increase the size and cost of the panel, both in terms of labour and components.

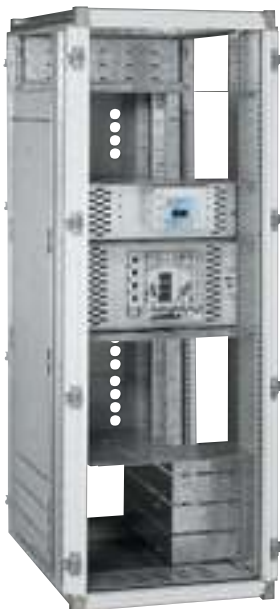

< Form 4b in the process of being set up in an XL³ enclosure

Form levels

As a general rule conformity with a higher level of form involves conformity with the lower levels of form, except for levels 3a, 2b and 2a.

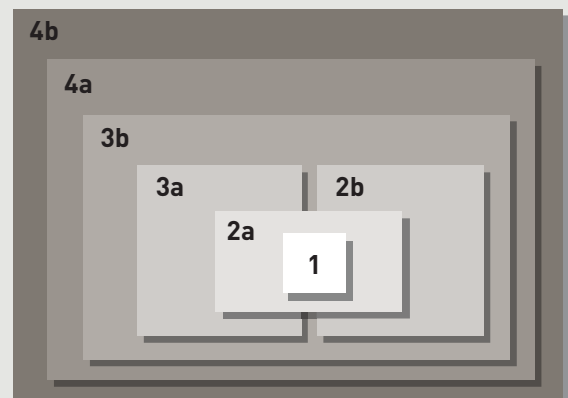

1 FORM 1

Form 1 does not require any separation between the components inside the enclosure.

2 FORMS 2a AND 2b

Form 2a is the simplest for protecting against accidental contact with the busbars, which are considered to be the most dangerous components. Form 2b includes additional separation to make it safe to work on outgoing lines.

Requirements of standards and creation in XL³ enclosures

■ Form 2a

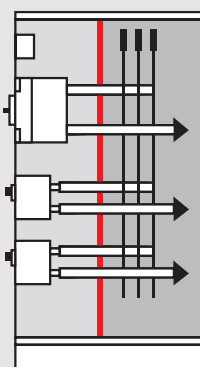

Separation of busbars from functional units.

Terminals for external conductors do not need to be separated from busbars.

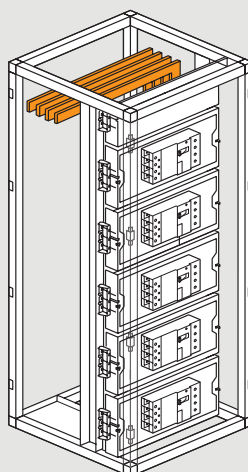

In XL³, the separation with the busbars is provided directly by the fixing plates. The devices are connected on rear terminals

■ Form 2b

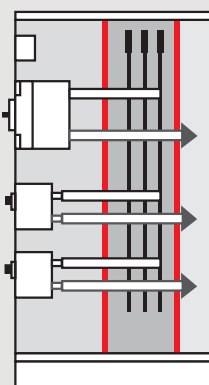

Separation of busbars from functional units.

Terminals for external conductors are separated from busbars.

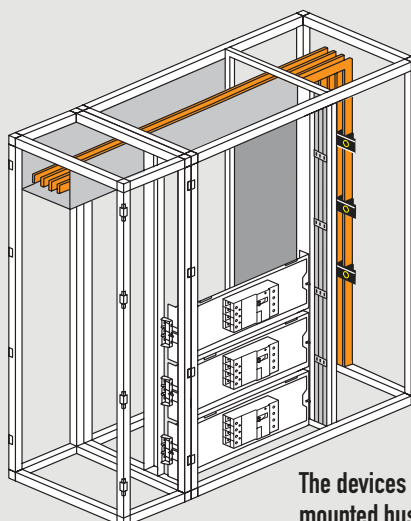

The devices are connected on the side-mounted busbar, on front terminals, through a vertical separation between the enclosure and the cable sleeve

Physical accessibility and protection provisions (continued)

3 FORMS 3a AND 3b

In form 3a, each device is isolated in a compartment which protects it from the effects of incidents which may occur on another device. Form 3b combines the advantages of form 3a and form 2b, separating the output terminals and the busbars.

Requirements of standards and creation in XL³ enclosures

■ Form 3a

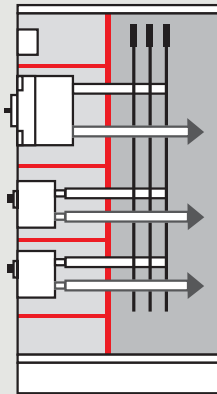

Separation of busbars from functional units and separation of all functional units from each other.

Terminals for external conductors are not separated from busbars.

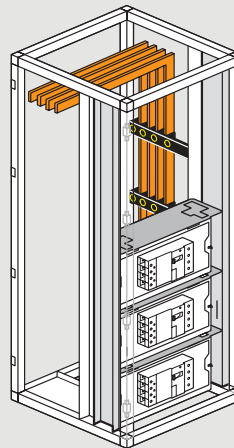

Form 3a is constructed based on form 2a with the addition of horizontal separations between the devices and vertical separations between the enclosures

■ Form 3b

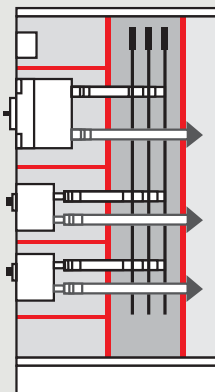

Separation of busbars from functional units and separation of all functional units from each other.

Terminals for external conductors are separated from busbars.

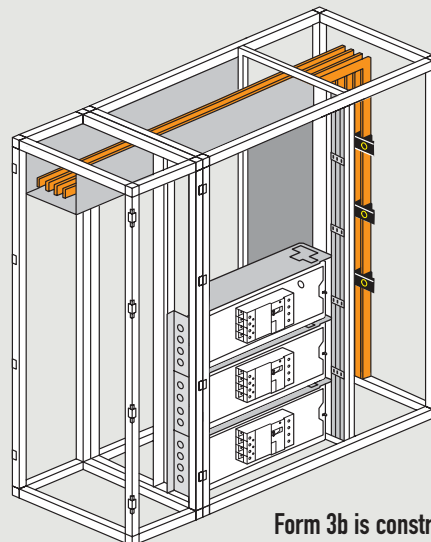

Form 3b is constructed based on form 2b with the addition of horizontal separations between the devices

4 FORMS 4a AND 4b

The requirements of form level 4a further increase the safety of working on outgoing lines by isolating the output terminals in the same compartment as the device. Form 4b provides maximum safety by separating all the functions from one another.

Requirements of standards and creation in XL³ enclosures

■ Form 4a

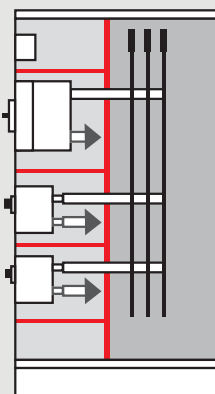

Separation of busbars from functional units and separation of all functional units from each other including the terminals for external conductors which are an integral part of the functional unit. Terminals for external conductors are in the same compartment as the functional unit.

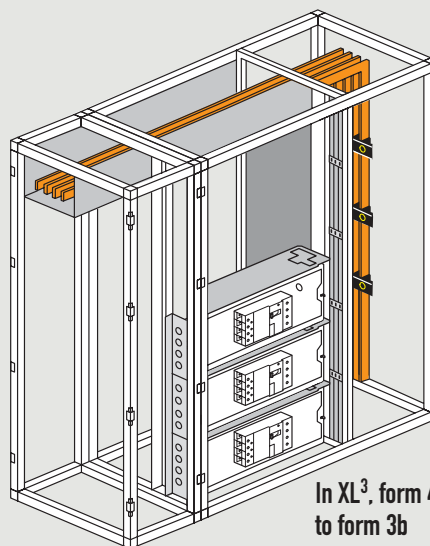

In XL³, form 4a is identical to form 3b

■ Form 4b

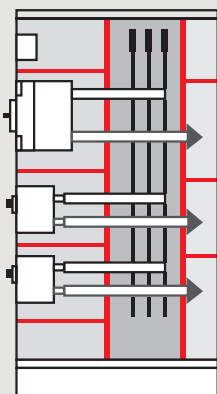

Separation of busbars from functional units and separation of all the functional units from each other including terminals for external conductors. Terminals for external conductors are not in the same compartment as the functional unit but in separate individual compartments.

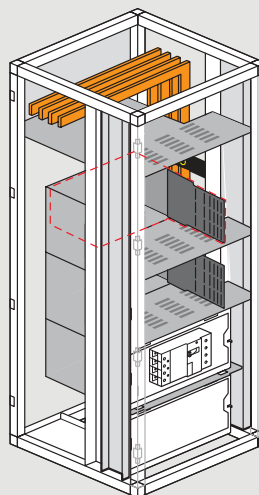

Each device is enclosed in a compartment. These compartments are stacked on top of each other and thus create the separation for the branch busbar

Physical accessibility and protection provisions (continued)

5 DETERMINING FORMS WITH XL PRO² SOFTWARE

5.1. Input data

To produce a design that includes forms, two mandatory pieces of information must be entered:

- The choice of product (DPX – DMX³ – DX)
- The associated busbar

A busbar can be associated with the main device either in the “Nomenclature” module (Cabling products > Associated busbars and distribution blocks) or in the “Arrangement” module (right-click on the circuit breaker, select “Associate with this product” and then “Associated busbars”).

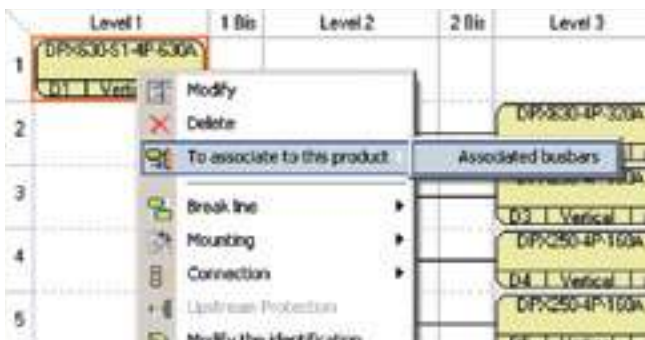

The busbar must be “top horizontal” or “side vertical” as these are the only distribution arrangements that can be partitioned in forms. If the assembly consists of more than two enclosures, the vertical busbars will be automatically connected using a top horizontal busbar. The horizontal busbar can be removed later if necessary.

XL-Pro² automatically creates branch busbars and the cable sleeves used to mount them.

5.2. Arrangement

Irrespective of the level of form required, the reference position for DPX is horizontal mounting.

In the “Arrangement” window, select all the devices then right-click to select “Mounting” then “Horizontal” (or click directly on the icon ). All the devices selected will be transformed into horizontal mounting position (if this was not already the case).

If the DPX are not positioned horizontally, XL-Pro² will do this automatically when the type of form is chosen, except in the case of supply inverters.



For horizontally mounted supply inverters, select the inverter in the “Arrangement” window and right-click to select “Inverter mounting” and then “Horizontal”.

Depending on the installation of the panel, select whether devices will be connected via front terminals or rear terminals.

In the “Arrangement” window, select all the devices then right-click to select “Connection” then “Front Terminals” or “Rear Terminals” (or click directly on the icon ).

All the devices selected will be transformed into front terminal or rear terminal connection depending on the choice made.



5.3. Selecting the enclosures

Products are selected in the same way as for a standard design.

In the “Enclosures” window click on the “Forms...” button. If the panel does not have any associated busbars, XL-Pro² suggests adding one.

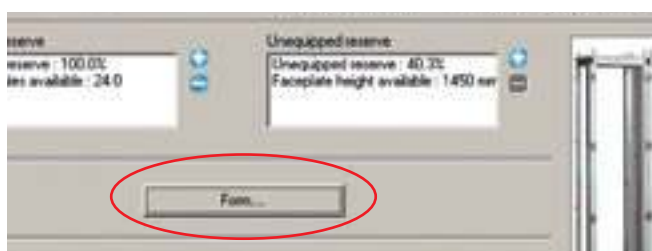

A window divided into 3 sections opens, for selecting:

1. The level of form required
2. The type of connection (front terminal or rear terminal)
3. The circuit diagram (power supply from the right, left or a “head-to-tail” power supply)

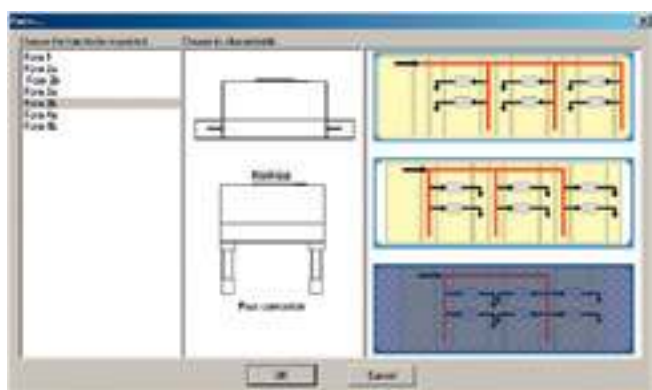

5.4. Preview

Once this information has been entered, XL-Pro² recalculates which enclosures are compatible. If the message “No family accepts the products selected” appears, this means that a product is incompatible with the enclosure configurations used to create the level of form required.

Example: technical impossibility of mounting a DPX-IS horizontally as mounting plates are only available for mounting in a vertical position. For these specific cases concerning DPX-IS, it is advisable to use special plates and faceplates for vertical mounting, with connection on the front terminals, and to partition the space between the mounting plates using adjustable solid plates.

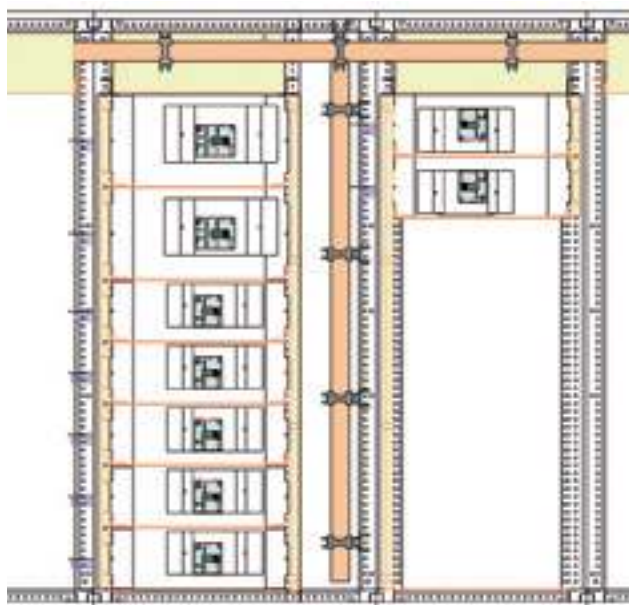

The “head-to-tail” circuit diagram is used to limit the number of branch busbars (and therefore the amount of copper used) but it requires alternate mounting of circuit breakers in the same enclosure assembly. In this case, the direction of opening must be clearly marked in order to ensure there is no ambiguity.

Motorisation and supply inversion

Motor-driven control can be used both in automated processes and safety processes (priority of service, breaking for fire, etc.). They enable remote control of supply circuits and load circuits in the context of building management. Automatic supply inversion is one of the main applications of motor-driven control.

MOTOR-DRIVEN CONTROL

Motor-driven controls enable remote control of the operation of the remote devices (on, off, reset). They are associated with appropriate electrical control layouts according to requirements.

In direct control layouts, operation is not instant and the changes of state take a few seconds. They are used more in control sequences in which this time is taken into account.

It is not advisable to use them for “emergency breaking” and their use must be prohibited for “emergency stops”.

Examples of layouts for these emergency functions are given on pages 27 and 29.

Layouts with control auxiliaries can be used in all situations. They enable multiple operations and pulse control, incorporating notions of positive safety (undervoltage releases).



^ The motor-driven controls for DPX can be installed in the factory or directly on-site on wired devices



^ Motor-driven controls for DMX³



^ Motor-driven controls for DPX

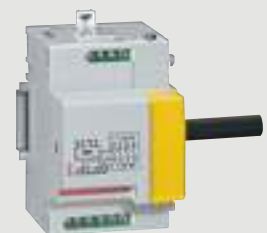

^ Motor-driven controls for DX

SUPPLY INVERTERS

Supply inversion meets the dual requirement of continuity of service and increased safety. Historically used in hospitals, public buildings, continuous production processes, airport and military applications, there is now increasing demand for supply inversion in telecommunications and data processing applications and also in the management of "renewable" energy sources.

Supply inversion performs the following functions:

- Switching from a main (or normal) supply to a standby (backup) supply in order to supply circuits that require continuity of service
- Switching from a main supply to a standby supply

(2nd supply) for managing energy sources (energy saving by using sources other than the network, which may be linked to a load-shedding function)
 - Management of the operation of the safety supply for supplying safety circuits.



The supply inversion control system must not be confused with an uninterruptible power supply (UPS).



The supply inversion device ensures continuity of operation by switching over to a standby supply if there is a fault on the main supply. This supply inversion is carried out totally safely due to the mechanical and electrical interlocking devices.

It can be classified into three categories, depending on the degree of automation of the function.

- **Manual:** The simultaneous closing of both devices is prohibited by a mechanical interlock device integrated in the devices' support plate. It is only possible to close one device if the other device is open.
- **Remote control:** The devices are equipped with "motor-driven controls". The closing and opening operations are therefore carried out remotely. The electrical layout and the control system must be created on a case by case basis depending on the requirements.
- **Automatic:** A control unit manages the inversion. The switchover to the standby supply is carried out automatically if there is a fault on the main supply, and vice versa after the restoration of this supply.



< Assembly with DMX³ supply inverter

Motorisation and supply inversion (continued)

Legrand supply inverters are available in three categories (manual, remote control and automatic) with DPX 160, 250 ER, 250, 630, 1600, DMX³ 2500, 4000 and DMX-E devices in fixed and draw-out circuit breaker or switch versions.

Like motor-driven controls, supply inversion can be carried out in accordance with two control principles:

- One, without coils, which enables simplified wiring but involves longer operating times (a few seconds)
- The other, based on the use of shunt coils mounted in the devices, which provides virtually instant changes of state.

In practice, the emergency breaking function applied to inversion devices can only be provided without adding any components with the second principle, or by adding control coils with the first principle.



^ DPX supply inverter with motor-driven controls

CONTROL UNITS

Legrand control unit Cat. No. 261 93 is used for simple control of the automatic switching of two sources. Controlled by a microprocessor, it is fully programmable. All the parameters are adjustable: voltage thresholds, switching times, startup of a generator set, etc.

The state of the inverter and the presence of voltages and their values for each source can be constantly monitored via the digital and LED display on the front panel.

Unit Cat. No. 261 94 has the same characteristics and can in addition be controlled remotely using supervision software via a link to a PC.



Supply inverter >
control panel with control unit

Front panel of control unit

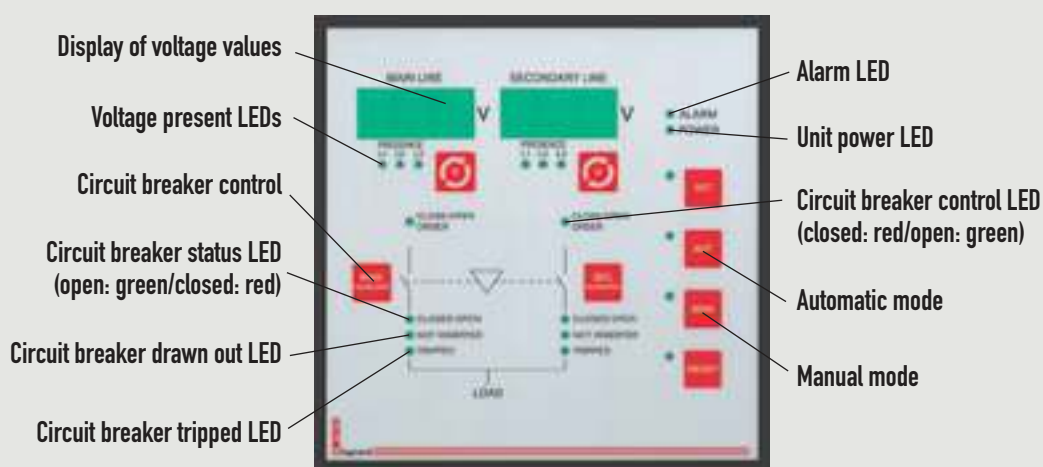

Example of logic diagram of operation for automatic supply inversion

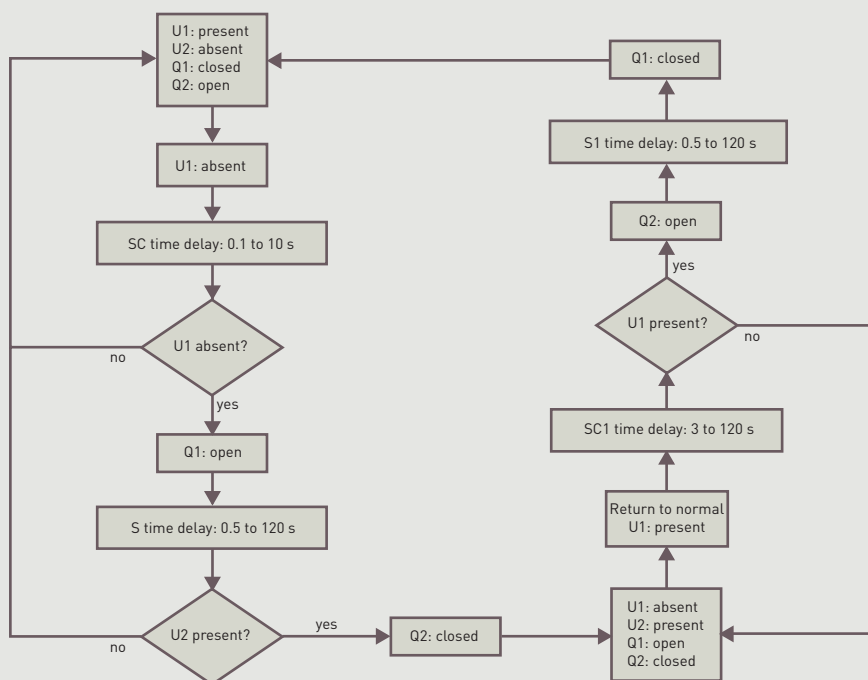

Emergency breaking and stops, isolation

As their name indicates, emergency operations are intended to eliminate, as quickly as possible, a danger which occurs unexpectedly. The emergency break is designed to cut off the electrical power, whereas the emergency stop takes account of the danger of mechanical movements.

EMERGENCY BREAKING

Emergency breaking is normally required for all installations in which there may be faults or risks of electric shocks: laboratories, boiler rooms, kitchens, illuminated signs, pumping of flammable liquids, test platforms, etc.

It must break all live conductors (including neutral, but not PE or PEN).

This must be possible on load and in a single operation.

Standard IEC 60364-5-53 defines the conditions for emergency breaking. Specific regulations can extend its application to other circuits.

In principle, the emergency breaking device should be located on or near the devices(s) to be broken, and be easily identifiable (by operating or emergency staff). On/off functional control devices (such as switches, contactors, circuit breakers) can be used for emergency breaking if they meet the above requirements. It should be noted that in this case, the breaking of single phase (ph + N) terminal circuits is possible with a single pole device. This provision applies in particular to lighting circuits.

The emergency breaking device can be located remotely in the secondary distribution board which supplies all the local circuits, as long as it is easily accessible, identifiable and installed in a location where the danger may occur or be detected.

This provision is designed to avoid accidental operation of the emergency breaking devices by limiting access

to operating staff (for example, in public buildings).

Caution: if the door of the board concerned is closed and locked with a key, a separate mechanical control or an external electrical control is necessary.

In installations in non-industrial or commercial premises, offices (or similar, measuring less than 500 m²), the main control and protection device at the origin of the installation may be used for emergency breaking, if it is easily accessible.

If there is a need for proximity of the device (in view of the dangers) and inaccessibility is required under normal conditions, emergency breaking must be via a "glass break" device with either direct control (pushbutton) or key release.

For the safety of machinery...



...the emergency stop is defined by standard IEC 60204-1 - a red button on a yellow background

For certain areas or equipment (boiler rooms, cooking equipment, large kitchens, illuminated signs, etc.) the emergency breaking must be:

- Either positive safety type (undervoltage release coils)
- Or accompanied by indication of the open/closed state (indicators, etc.) showing the position of the breaking device.

It should be noted that separate lighting devices/other circuits may also be required (for example, in boiler rooms).

It must be possible to lock the emergency break operating device in the off position.

If this is not possible, the operation to release

the emergency break and re-establish the supply must be carried out by the same person. It is therefore recommended that it must only be possible to perform these two operations from two locations that are near to one another and visible.



The requirements relating to emergency breaking, functional control, emergency stops and isolation are described in standard IEC 60364-5-53.



Emergency breaking and stops, isolation (continued)

+



Accessible direct control: all the breaking devices in the DX, DPX, DPX-IS, Vistop and SPX-D ranges can be used for emergency breaking.



Separate control (if the breaking device is inaccessible or in a panel locked with a key): Vistop, DPX-IS, DPX and SPX-D devices can be equipped with external front or side handles.

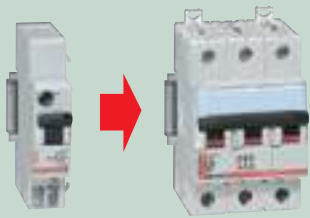

Remote control: DX, DPX and DPX-IS circuit breakers and residual current circuit breakers can be equipped with shunt trips or undervoltage releases.



It must be possible to use emergency breaking methods, other than the emergency stop (see p. 28), to eliminate an unexpected danger. Examples of this include: ventilation or pumping systems, neon signs, certain important buildings, laboratories, boiler rooms, large kitchens, etc.

The notions of positive safety (use of undervoltage releases) and locking in breaking position are required for these uses, as well as the use of clearly identified devices (red on a contrasting background). In practice, the use of undervoltage release devices must be avoided too far upstream of the installation as they lead to breaking of the main circuits when there is a drop in voltage.

However these devices are not necessary for terminal circuits that do not present any particular danger: heating, lighting, power sockets.

Examples of emergency breaking

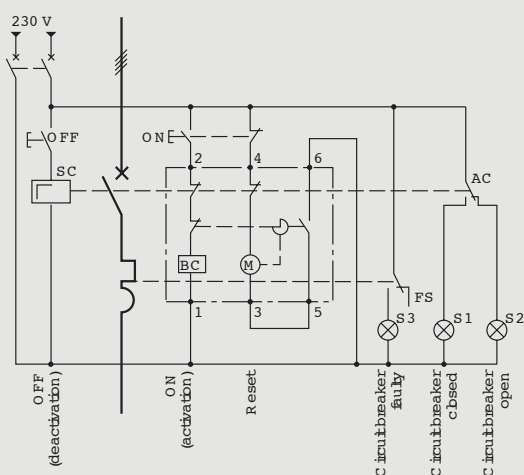

Motor-driven control of a DPX circuit breaker with emergency breaking by the off button OFF and shunt coil. Manual reset.

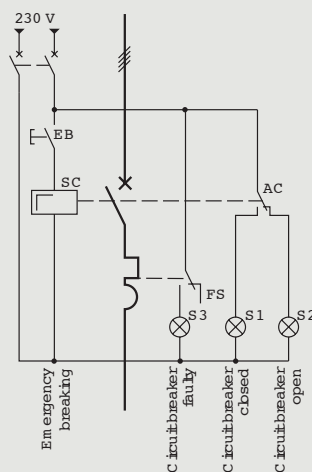

Direct control of a DPX circuit breaker. Emergency breaking is carried out by the off button EB and the shunt coil SC.

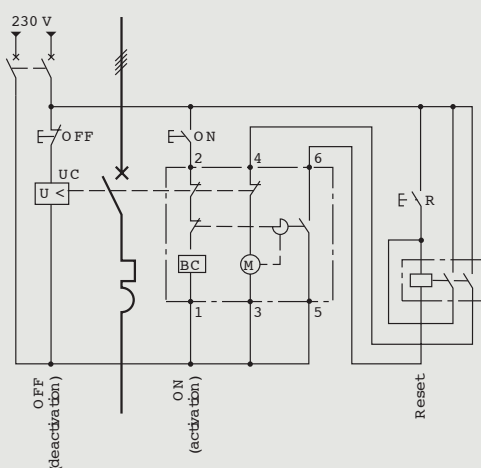

Motor-driven control for DPX circuit breaker with reset by external handle. Opening by undervoltage release.

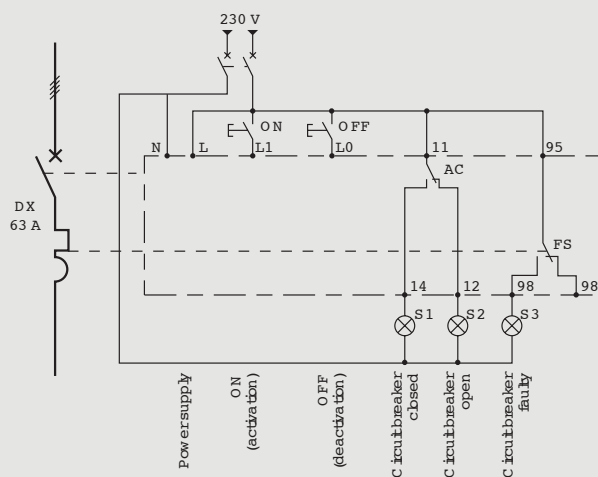

Wiring of motor-driven control Cat. No. 073 70/71/73 for DX circuit breakers. The off button OFF can be used for emergency breaking.

AC: auxiliary contact
FS: fault signal contact
SC: shunt coil
UC: undervoltage coil

EB: emergency breaking
ON: ON button
OFF: OFF button
R: reset

Emergency breaking and stops, isolation (continued)

THE EMERGENCY STOP

When movements produced by electrical devices or machines can be the source of danger, these devices or machines must be equipped with emergency stop device(s) located as close as possible to the users. Emergency stops are required for example for escalators, lifts and elevators, cranes and transporters, electrically controlled doors, car washes, etc. And of course for machines: mechanical kneading machines, handling robots, and machine tools in the broadest sense.

Each machine must be fitted with one or more emergency stop devices, which are clearly identifiable, accessible, in sufficient numbers, avoiding dangerous situations arising or continuing.

The stop can be immediate, controlled or delayed, depending on the requirements of the machine, with the power supply only being cut off when the stop takes place.

The emergency stop is not required:

- If its presence does not reduce the risk

- If the stopping time is not shorter than the emergency break

- For portable machines and manually guided machines.



The emergency stop must be activated by as direct an action as possible and with the notion of “positive safety”: direct action on the contacts opening the circuit or stop given priority in the event of a fault on the equipment or the power supply.



European directive 98/37/EC (concerning machinery) sets technical requirements with which the said machinery and work equipment must comply, including the emergency stop.

Emergency stop for the safety of machinery



Control station with yellow cover and red “push-turn” mushroom head button conforming to standard IEC 60204-1 (1/4 turn to unlock).

Emergency stop devices must be provided for any part of an installation for which it may be necessary to control the power supply in order to eliminate an unexpected danger.

The emergency stop is intended to eliminate a danger, which does not necessarily have an electrical origin, as quickly as possible.

Examples of emergency stops

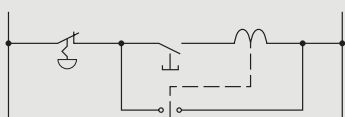

Conventional layout of supply to a relay with switch-off priority.

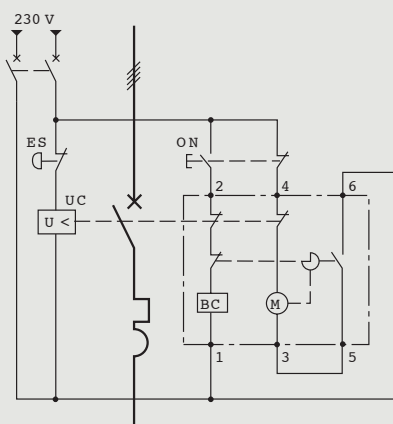

Motor-driven control for DPX circuit breaker with automatic reset after closing of the circuit breaker. Opening by undervoltage coil.

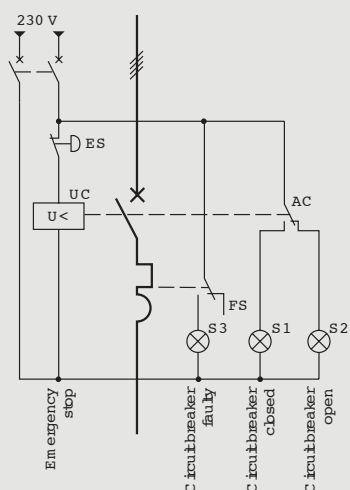

Direct on DPX circuit breaker by "mushroom head" button and undervoltage coil.

AC: auxiliary contact ON: ON button
 FS: fault signal contact ES: emergency stop
 UC: undervoltage coil



Time-lag (800 ms) undervoltage releases prevent unwanted stopping in the event of micro-breaks.

Emergency breaking and stops, isolation (continued)

ISOLATION

Used to separate an installation or part of an installation electrically, the purpose of isolation is to ensure the safety of people working on it.

A breaking device providing the isolation function must be installed:

- At the origin of all installations
 - At the origin of each circuit or group of circuits
- The isolator must break all the live conductors (including the neutral).

PE and PEN must not be broken.

Isolation does not have to be carried in a single operation (commoning links, fuse carriers), although multipole devices are preferable.

If there is a risk of backfeed, isolation upstream and downstream of the installation may be necessary. The devices which carry out isolation may be isolators, isolating switches, circuit breakers, power sockets, fuse carriers, isolating blades, disconnect terminals or any device which provides a minimum contact opening distance of:

- 4 mm for 230/400 V voltage
- 8 mm for 400/690 V voltage
- 11 mm 1000 V voltage

For double break devices, the distances must be multiplied by 1.25.

1 ISOLATION WITH PERMANENT CONTACT INDICATION

This characteristic is checked by reliable control between the position of the contacts and that of the control switch handle. The indication "I" or "O" (red or green) on the handle thus guarantees the actual contact position. Compliance with standard IEC 60947-2 is evidence of this.



Caution: isolation does not on its own ensure that the installation is made safe. Appropriate methods must be employed to prevent any unwanted re-energising (padlocking, signs, locked rooms, earthing) and lock out the installation (see p. 03).



Requirements concerning isolation are also applicable to machines and work equipment that have to be isolated from their power source(s) in order to carry out adjustment operations or maintenance work. European directive 98/37/EC details the requirements: separation, immobilisation and checking in order to lock out the machine or device.

Full load switch units...



...full load switch units carry out both emergency breaking and isolation

2 ISOLATION WITH VISIBLE CONTACT INDICATION

The actual position of the separate contacts is directly visible. Visible contact indication can be obtained by means of a display window (Vistop, DPX-IS) or by using plug-in or draw-out devices (DPX, DMX³).

It is important to clearly identify the local requirements concerning isolation. For example in France visible contact indication is required for subscriber stations whose power does not exceed 1250 kVA, supplied by a single transformer with LV metering. It is also required upstream of the supply point for monitored power connections.



Other definitions

- **Protective breaking:**
Breaking associated with a protective function (overcurrents, residual current fault, overvoltage, etc.).
- **Functional control:**
Control of operation (on, off, variation) for solely functional purposes: thermostats, dimmers and remote control switches are examples of this. Power sockets > 32 A cannot perform functional control of a device. They must be combined with a load breaking device.
- **Breaking for mechanical maintenance:**
Breaking solely intended to avoid mechanical risks (movement) during non-electrical work. If they only have this function, they cannot be used for emergency breaking purposes.



Choice of products



286 56

DMX³ ACBs and DMX³-I TRIP-FREE SWITCHES

	DMX ³ -N 2500 - 4000				DMX ³ -H 2500 - 4000				DMX ³ -L 2500 - 4000				
Icu (400 V AC)	50 kA				70 kA				100 kA				
Version	Fixed		Draw-out		Fixed		Draw-out		Fixed		Draw-out		
Poles	3P	4P	3P	4P	3P	4P	3P	4P	3P	4P	3P	4P	
In (A)	800	286 21	286 31	287 21	287 31	286 41	286 51	287 41	287 51	286 61	286 71	287 61	287 71
	1000	286 22	286 32	287 22	287 32	286 42	286 52	287 42	287 52	286 62	286 72	287 62	287 72
	1250	286 23	286 33	287 23	287 33	286 43	286 53	287 43	287 53	286 63	286 73	287 63	287 73
	1600	286 24	286 34	287 24	287 34	286 44	286 54	287 44	287 54	286 64	286 74	287 64	287 74
	2000	286 25	286 35	287 25	287 35	286 45	286 55	287 45	287 55	286 65	286 75	287 65	287 75
	2500	286 26	286 36	287 26	287 36	286 46	286 56	287 46	287 56	286 66	286 76	287 66	287 76
	3200	286 27	286 37	287 27	287 37	286 47	286 57	287 47	287 57	286 67	286 77	287 67	287 77
4000	286 28	286 38	287 28	287 38	286 48	286 58	287 48	287 58	286 68	286 78	287 68	287 78	

Electronic protection units and accessories

Electronic protection units			Communication module	12 V dc external power supply	Earth leakage module	External coil for earth leakage module	Module programmable output
MP4 LI	MP4 LSI	MP4 LSIg					
288 00	288 01	288 02	288 05	288 06	288 07	288 11	288 12

DMX³-I 2500 - 4000

Version	Fixed		Draw-out		
Poles	3P	4P	3P	4P	
In (A)	1250	286 83	286 93	287 83	287 93
	1600	286 84	286 94	287 84	287 94
	2000	286 85	286 95	287 85	287 95
	2500	286 86	286 96	287 86	287 96
	3200	286 87	286 97	287 87	287 97
	4000	286 88	286 98	287 88	287 98

Conversion of a fixed device into a draw-out device

Device	DMX ³ /DMX ³ -I 2500		DMX ³ /DMX ³ -I 4000	
Poles	3P	4P	3P	4P
Base for draw-out device	289 02	289 03	289 04	289 05
Transformation kit	289 09	289 10	289 11	289 12



287 56



288 51



288 37



288 82



288 96

Control auxiliaries

Supply	Shunt trips	Undervoltage releases	Delayed undervoltage releases	Motor operators	Closing coils
24 V AC/DC	288 48	288 55		288 34	288 41
48 V AC/DC	288 49	288 56		288 35	288 42
110 V AC/DC	288 50	288 57	288 62	288 36	288 43
230 V AC/DC	288 51	288 58	288 63	288 37	288 44
415 V AC	288 52	288 59		288 38	288 45
440 V AC	288 53	288 60		288 39	288 46
480 V AC	288 54	288 61		288 40	288 47

Locking options

	Key locking in "open" position	Key locking in "draw-out" position	Door locking	Padlocking in "open" position
Ronis lock	288 30	288 33		
Profalux lock	288 31	288 32		
2 hole support frame for above locks	288 28			
Left-hand and right-hand side mounting			288 20	
Padlocking system for ACBs				288 21
Padlocking system for safety shutters				288 26

Equipment for supply invertors

	Interlocking mechanism	Interlocking cable						Automation control unit	
		Type 1	Type 2	Type 3	Type 4	Type 5	Type 6	Standard	Communicating
DMX ³ 2500	288 64	289 20	289 21	289 21	289 21	289 21	289 21	261 93	261 94
DMX ³ 4000	288 65								

Accessories for connexion with bars

Accessories	Connexion	DMX ³ 2500				DMX ³ 4000			
		Fixed version		Draw-out version		Fixed version		Draw-out version	
		3P	4P	3P	4P	3P	4P	3P	4P
Rear terminals	Flat	288 84	288 85			288 92	288 93		
	Vertical	288 82	288 83	288 96	288 97			288 94	288 95
	Horizontal			288 96	288 97			288 94	288 95
Spreaders	Flat	288 86	288 87			288 86	288 87		
	Vertical	288 88	288 89			288 88	288 89		
	Horizontal	288 90	288 91			288 90	288 91		



6261 29



6261 17

DMX-E AIR CIRCUIT BREAKERS

		DMX-E 55				DMX-E 65			
Icu (415 V AC)		55 kA				65 kA			
Version		Fixed		Draw-out		Fixed		Draw-out	
Poles		3P	4P	3P	4P	3P	4P	3P	4P
In (A)	800	6260 02	6260 12	6260 22	6260 32	6260 42	6260 52	6260 62	6260 72
	1000	6260 03	6260 13	6260 23	6260 33	6260 43	6260 53	6260 63	6260 73
	1250	6260 04	6260 14	6260 24	6260 34	6260 44	6260 54	6260 64	6260 74
	1600	6260 05	6260 15	6260 25	6260 35	6260 45	6260 55	6260 65	6260 75
	2000					6260 46	6260 56	6260 66	6260 76
	2500					6260 47	6260 57	6260 67	6260 77

		DMX-E 80				DMX-E 100			
Icu (415 V AC)		80 kA				100 kA			
Version		Fixed		Draw-out		Fixed		Draw-out	
Poles		3P	4P	3P	4P	3P	4P	3P	4P
In (A)	2000	6260 86	6260 96	6261 06	6261 16	6261 26	6261 36	6261 46	6261 56
	2500	6260 87	6260 97	6261 07	6261 17	6261 27	6261 37	6261 47	6261 57
	3200	6260 88	6260 98	6261 08	6261 18	6261 28	6261 38	6261 48	6261 58
	4000	6260 89	6260 99	6261 09	6261 19	6261 29	6261 39	6261 49	6261 59

Conversion of a fixed device into a draw-out device

In	Bases for draw-out device								Rear terminals (supplied singly)	
	DMX-E 55		DMX-E 65		DMX-E 80		DMX-E 100		Horizontal	Vertical
	3P	4P	3P	4P	3P	4P	3P	4P		
800 to 1600 A	6263 86	6263 87	6263 86	6263 87					6263 30	6263 30
2000 and 2500 A			6263 88	6263 89	6263 88	6263 89	6263 90	6263 91	6263 31	6263 32
3200 and 4000 A					6263 90	6263 91	6263 90	6263 91	6263 30	6263 30

Interlocking mechanism for supply invertors

1 standard power supply + 1 standby power supply	3 power supplies	2 standard power supplies + 1 standby power supply	2 standard power supplies + 1 coupler
6263 80	6263 81	6263 82	6263 83

Control auxiliaries

Supply		Shunt trips	Undervoltage releases	Delayed undervoltage releases	Motor operators	Closing coils
DC	24/30 V	6262 60	6262 70		6262 91	6263 00
	48 V		6262 71	6262 81	6262 92	6263 01
	60 V				6262 92	6263 01
	110 V	6262 62	6262 74	6262 84	6262 93	6263 02
	125 V				6262 93	
	220 V	6262 64				6263 04
	250 V	6262 64			6262 95	6263 04
AC 50 Hz	400 V				6262 96	
	110 V	6262 62	6262 72	6262 82	6262 93	6263 02
	220 V	6262 64				
	240 V	6262 64	6262 77	6262 87	6262 95	6263 04
	250 V					
	380 V		6262 79	6262 89	6262 96	
AC 60 Hz	415 V	6262 65	6262 79	6262 89	6262 96	6263 05
	110 V	6262 62	6262 73	6262 83	6262 93	6263 02
	220 V	6262 64				6263 04
	240 V	6262 64	6262 78	6262 88	6262 95	6263 04
	380/415 V	6262 65	6262 80	6262 90	6262 96	6263 05

Signalling auxiliaries

Position signal contact	Fault signal contact	True "ready to close" contact	Shunt release action signal contact	Undervoltage release action signal contact
6263 11	6263 17	6263 18	6263 15	6263 16

Locking options

For lock (not supplied)	Key locking in "open" position	Key locking in "draw-out" position	Door locking
Ronis	6263 40	6263 45	
Profalux	6263 41	6263 46	
Castell	6263 42	6263 47	
Kirk	6263 43	6263 48	
None			6263 22

Accessories

Rating mis-insertion device	Operation counter	Test box
6263 20	6263 24	6263 79



250 18



250 59

DPX CIRCUIT BREAKERS AND DPX-I TRIP-FREE SWITCHES

DPX-E 125 and DPX 125

Icu (400 V)*	16 kA				25 kA		36 kA			
Poles	1P	3P	3P + ½ N	4P	3P	4P	3P	3P + ½ N	4P	
In (A)	16	250 00	250 16		250 24	250 36	250 44	250 50		250 58
	20	250 01								
	25	250 02	250 17		250 25	250 37	250 45	250 51		250 59
	32	250 03								
	40	250 04	250 18		250 26	250 38	250 46	250 52		250 60
	50	250 05								
	63	250 06	250 19		250 27	250 39	250 47	250 53		250 61
	80	250 07								
	100	250 08	250 20		250 28	250 40	250 48	250 54		250 62
	125	250 09	250 21	250 23	250 29	250 41	250 49	250 55	250 57	250 63

* 230 V for 1P devices

DPX 160

Icu (400 V)	25 kA			36 kA			50 kA		
Poles	3P	3P + ½ N	4P	3P	3P + ½ N	4P	3P	3P + ½ N	4P
In (A)	40						251 62		251 70
	63	251 23		251 31	251 49		251 57	251 63	251 71
	100	251 24		251 32	251 50		251 58	251 64	251 72
	160	251 25	251 27	251 33	251 51	251 53	251 59	251 65	251 67

DPX 250 ER

Icu (400 V)	25 kA			36 kA			50 kA			
Poles	3P	3P + ½ N	4P	3P	3P + ½ N	4P	3P	3P + ½ N	4P	
In (A)	100	252 04		252 14	252 24		252 34	252 44		252 54
	160	252 05		252 15	252 25		252 35	252 45		252 55
	250	252 06	252 09	252 16	252 26	252 29	252 36	252 46	252 49	252 56



254 23



256 32



257 32

DPX 250

Release		Thermal magnetic						Electronic			
Icu (400 V)		36 kA			70 kA			36 kA		70 kA	
Poles		3P	3P + ½ N	4P	3P	3P + ½ N	4P	3P	4P	3P	4P
In (A)	40	253 28		253 45	253 52		253 69	254 01	254 07	254 13	254 19
	63	253 29		253 46	253 53		253 70				
	100	253 30		253 47	253 54		253 71	254 03	254 09	254 15	254 21
	160	253 31	253 41	253 48	253 55		253 72	254 04	254 10	254 16	254 22
	250	253 32	253 42	253 49	253 56	253 66	253 73	254 05	254 11	254 17	254 23

DPX 630

Release		Thermal magnetic						Electronic			
Icu (400 V)		36 kA			70 kA			36 kA		70 kA	
Poles		3P	3P + ½ N	4P	3P	3P + ½ N	4P	3P	4P	3P	4P
In (A)	250	255 21		255 36				256 01	256 05		
	320	255 22	255 32	255 37	255 42	255 52	255 57				
	400	255 23	255 33	255 38	255 43	255 53	255 58	256 02	256 06	256 10	256 14
	500	255 25	255 35	255 39	255 45	255 55	255 59				
	630	255 24	255 34	255 40	255 44	255 54	255 60	256 03	256 07	256 11	256 15

DPX 1250 - 1600

Release		Thermal magnetic				Electronic S1				Electronic S2			
Icu (400 V)		50 kA		70 kA		50 kA		70 kA		50 kA		70 kA	
Poles		3P	4P	3P	4P	3P	4P	3P	4P	3P	4P	3P	4P
In (A)	800	258 02	258 09	258 16	258 23	257 02	257 06	257 10	257 14	257 26	257 30	257 34	257 38
	1000	258 03	258 10	258 17	258 24								
	1250	258 04	258 11	258 18	258 25	257 03	257 07	257 11	257 15	257 27	257 31	257 35	257 39
	1600					257 04	257 08	257 12	257 16	257 28	257 32	257 36	257 40



253 99



265 32

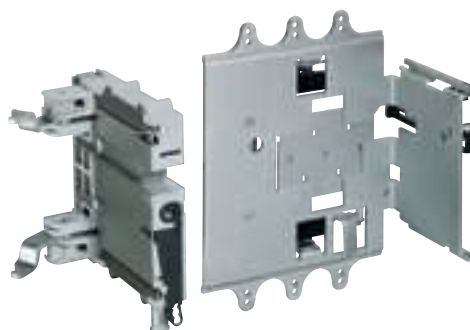

265 46

DPX-I trip-free switches

In (A)	DPX-I 125		DPX-I 160		DPX-I 250 ER		DPX-I 250		DPX-I 630		DPX-I 1600	
	3P	4P	3P	4P	3P	4P	3P	4P	3P	4P	3P	4P
125	250 98	250 99										
160			251 98	251 99								
250					252 98	252 99	253 98	253 99				
400									255 86	255 87		
630									255 88	255 89		
800											257 94	257 95
1250											257 96	257 97
1600											257 98	257 99

Equipment and accessories for plug-in and draw-out version

Devices		DPX 250 ER		DPX 250			DPX 630			DPX 1600		
		3P	4P	3P	4P	4P + earth leakage module	3P	4P	4P + earth leakage module	3P	4P	
Fixed version to plug-in version	Tulip contacts	265 12	265 13	265 29	265 30		265 50	265 51				
	Front terminal mounting base	265 14	265 15	265 31	265 32	265 37	265 52	265 53	265 58			
	Rear terminal mounting base	265 16	265 17	265 33	265 34	265 38	265 54	265 55	265 59			
	Flat rear terminal mounting base			265 35	265 36	265 39	265 56	265 57	265 60			
Fixed version to draw-out version (mounting base + tulip contacts + "Debro-lift" mechanism)	Front terminal									265 82	265 83	
	Rear terminal									265 84	265 85	
Plug-in version to draw-out version ("Debro-lift" mechanism)				265 45	265 46	265 47	265 66	265 67	265 68			
Set of connectors (6 pins)					098 19							
Set of connectors (8 pins)			263 99		263 99				263 99			
Extractor handles (set of 2)					263 43				263 68			
Isolated handle for drawing-out					265 75				265 75		265 75	
Signalling contact plugged-in/drawn-out					265 74				265 74		265 74	
Key lock for "Debro-lift" mechanism	DPX only				265 76				265 76		265 76	
	motorised DPX or rotary handle				265 78				265 78		265 80	



262 50 262 11 262 79 261 73 261 90

Accessories, rotary and motor driven handles

		DPX 125 DPX-I 125	DPX 160 DPX-I 160	DPX 250 ER	DPX 250	DPX 630	DPX 1600
Sealable terminal shields	3P	262 05	262 15	262 85	262 26/28 ⁽¹⁾	262 44	262 64
	4P	262 06	262 16	262 86	262 27/29 ⁽¹⁾	262 45	262 65
Insulated shield	set of 3				262 30	262 30	262 66
Padlocking accessory		262 00	262 10	262 10	262 21	262 40	262 60
Cage terminal		Supplied	262 18	262 88	262 35	262 50	262 69
High capacity cage terminal			262 19			262 51	262 70
Adaptator for lug					262 31	262 46	
Extended front terminals			262 17		262 32	262 47	262 67/68 ⁽²⁾
Spreaders	3P			262 90	262 33	262 48	262 73
	4P			262 91	262 34	262 49	262 74
Swivel rear terminals	3P	263 00	263 10	265 10	263 31	263 50	
	4P	263 01	263 11	265 11	263 32	263 51	
Flat rear terminals	3P				265 27	263 52	263 80/81 ⁽³⁾
	4P				265 28	263 53	263 82/83 ⁽³⁾
Direct rotary handle	standard	262 01	262 11	262 11	262 22	262 41	262 61
	for emergency use	262 03	262 13	262 13	262 24 ⁽⁴⁾	262 24 ⁽⁴⁾	
	Eurolocks locking accessory	262 25	262 25	262 25		262 25	262 25
Vari-depth handle	standard	262 75	262 77	262 77	262 79	262 81	262 83
	for emergency use	262 76	262 78	262 78	262 80 ⁽⁴⁾	262 82 ⁽⁴⁾	262 84
	Eurolocks locking accessory	262 92	262 92	262 92	262 92	262 92	262 92
	Profalux locking accessory	262 93	262 93	262 93	262 93	262 93	262 93
	Ronis locking accessory	262 94	262 94	262 94	262 94	262 94	262 94
Motor driven handle	24 V				261 30	261 40	
	230 V				261 34	261 44	261 54
	Ronis locking accessory				261 59	261 59	261 59

Auxiliaries

Supply	Auxiliary contact or fault signal	Shunt releases	Undervoltage releases		Time lag undervoltage releases		
			for DPX 125, DPX-IS 250/630	for DPX 160 to DPX 1600, DX-IS 1600, DPX-I	Time lag module	Release for DPX-IS, DPX 125/630	Releases for DPX 250 ER to DPX 1600
	261 60					261 75	261 85
24 V AC		261 64	261 70	261 80			
24 V DC		261 64	261 71	261 81			
48 V AC		261 65					
48 V DC		261 65	261 72	261 82			
110 V AC		261 66	261 76	261 86			
110 V DC		261 66					
230 V AC		261 67	261 73	261 83	261 90		
230 V DC		261 67					
400 V AC		261 68	261 74	261 84	261 91		
400 V DC		261 68					

(1) Long/short | (2) In ≤ 1250 A: Cat.No 262 67 - In = 1600 A: Cat.No 262 68 | (3) Short/long
 (4) To be fit on Cat.No 262 22



DRX CIRCUIT BREAKERS

DRX 100									
Icu (415 V)	10 kA		20 kA		25 kA	35 kA			
Poles	3P	4P	3P	4P	1P	2P	3P	4P	
In (A)	15	270 00	270 10	270 20	270 30	270 40	270 50	270 60	270 70
	20	270 01	270 11	270 21	270 31	270 41	270 51	270 61	270 71
	25	270 02	270 12	270 22	270 32	270 42	270 52	270 62	270 72
	30	270 03	270 13	270 23	270 33	270 43	270 53	270 63	270 73
	40	270 04	270 14	270 24	270 34	270 44	270 54	270 64	270 74
	50	270 05	270 15	270 25	270 35	270 45	270 55	270 65	270 75
	60	270 06	270 16	270 26	270 36	270 46	270 56	270 66	270 76
	75	270 07	270 17	270 27	270 37	270 47	270 57	270 67	270 77
100	270 08	270 18	270 28	270 38	270 48	270 58	270 68	270 78	

DRX 250							
Icu (415 V)	18 kA		25 kA		36 kA		
Poles	3P	4P	3P	4P	3P	4P	
In (A)	125	271 00	271 06	271 12	271 18	271 24	271 30
	150	271 01	271 07	271 13	271 19	271 25	271 31
	175	271 02	271 08	271 14	271 20	271 26	271 32
	200	271 03	271 09	271 15	271 21	271 27	271 33
	225	271 04	271 10	271 16	271 22	271 28	271 34

Electrical accessories					
Supply	Auxiliary contact bloc			Shunt trips	Undervoltage releases
	with 1 auxiliary	with 1 alarm	with 1 auxiliary + 1 alarm		
Up to 250 V AC/DC	271 40	271 41	271 42		
12 V AC/DC				271 50	271 60
24 V AC/DC				271 51	271 61
48 V AC/DC				271 52	271 62
110/130 V AC				271 53	271 63
200/240 V AC				271 54	271 64
277 V AC				271 54	271 67
380/415 V AC				271 55	271 65
440/480 V AC				271 55	271 66

Connection accessories, padlocking and rotary handles					
Device	DRX 100			DRX 250	
Poles	2P	3P	4P	3P	4P
Insulating shields		271 81	271 82	271 81	271 82
Seasable terminal shields	271 91	271 83	271 84	271 85	271 86
Cage terminal*	Up to 50 A	271 70	271 72		
	from 60 to 100 A	271 71	271 73		
	Up to 250 A			271 74	271 75
Padlocking system (up to 3 padlocks)		271 80		271 81	
	Direct on DRX		271 76		271 78
Rotary handle					
	Vari-depth handle		271 77		271 79

* Available by set of 60 pieces: Cat.No 271 92 (up to 50 A), Cat.No 271 93 (60 to 100 A), Cat.No 271 94 (up to 250 A)



266 70



255 98



225 15

DPX-IS AND VISTOP ISOLATING SWITCHES

DPX-IS isolating switches

Model	In (A)	With release						Without release					
		Front handle		Right-hand side handle		Left-hand side handle		Front handle		Right-hand side handle		Left-hand side handle	
		3P	4P	3P	4P	3P	4P	3P	4P	3P	4P	3P	4P
DPX-IS 250	63	266 30	266 34	266 40	266 44	266 50	266 54						
	100	266 31	266 35	266 41	266 45	266 51	266 55						
	160	266 32	266 36	266 42	266 46	266 52	266 56	266 02	266 06	266 12	266 16	266 22	266 26
	250	266 33	266 37	266 43	266 47	266 53	266 57	266 03	266 07	266 13	266 17	266 23	266 27
DPX-IS 630	400	266 72	266 74	266 76	266 78	266 80	266 82	266 60	266 62	266 64	266 66	266 68	266 70
	630	266 73	266 75	266 77	266 79	266 81	266 83	266 61	266 63	266 65	266 67	266 69	266 71
DPX-IS 1600	800	265 91	265 95										
	1000	265 92	265 96										
	1250	265 93	265 97										
	1600	265 94	265 98										

Vistop isolating switches

Mounting	In (A)	Front handle			Side handle			Auxiliary contact for on/off signalling
		2 P	3 P	4 P	2 P	3 P	4 P	
On faceplate	32	224 98	225 00	225 02	225 03	225 05	225 07	
On faceplate or rail	63		225 12	225 15		225 16	225 18	227 07
	100		225 20	225 22		225 25	225 27	
	125		225 34	225 39		225 44	225 46	
	160		225 51	225 53		225 54	225 56	

Accessories

		DPX-IS 250	DPX-IS 630	DPX-IS 1600	Vistop 63 to 160 A
Direct handle for emergency use	front and right-hand side	266 89	266 89		
	left-hand side	266 90	266 90		
Vari-depth handle	for standard handle	266 86	266 86	265 89	
	for emergency handle	266 87	266 87	265 90	
Front external handle					227 32
Palock	Ronis	266 92	266 97		
Locking accessories for vari-depth handle	Euro locks			262 92	
	Profalux			262 93	
	Ronis			262 94	
Terminal shields	2P	262 87	262 45	262 64	
	3P			262 65	
Insulation shields				262 66	



208 92

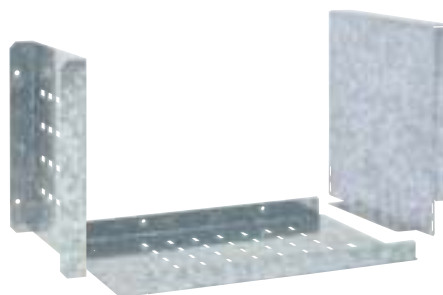

208 75

XL³ 4000 FORMS

Forms equipment selection

Designation	Complementary information	Forms of separation and type of connection (terminals)							
		2a rear terminal	2b front terminal	2b rear terminal	3a rear terminal	3b front terminal	3b rear terminal	4a front terminal	4b rear terminal
Top or bottom horizontal separation kit	width 24 modules	208 91				208 91	208 91	208 91	208 91
	width 36 modules	208 99				208 99	208 99	208 99	208 99
Front panel separation DMX ³ 2500	width 24 modules	208 08			208 08				
Front panel separation DMX ³ 4000	width 36 modules	208 09			208 09				
Front panel side separation					208 68		208 68		208 68
Horizontal separation for functional units	width 24 modules			208 92	208 92	208 92	208 92	208 92	208 92
	width 36 modules			205 92	205 92	205 92	205 92	205 92	205 92
Kit for vertical separation between enclosure and cable sleeve	depth 475 mm		208 27			208 27		208 27	
	depth 725 mm		208 28			208 28		208 28	
	depth 975 mm		208 29			208 29		208 29	
Kit for vertical separation between internal cable sleeve and external cable sleeve	depth 475 mm		208 37			208 37		208 37	
	depth 725 mm		208 38			208 38		208 38	
	depth 975 mm		208 39			208 39		208 39	
L-shaped separation kit for horizontal busbars 1600 A max.	depth 475 mm		205 36			205 36		205 36	
U-shaped separation kit for horizontal busbars 1600 A max.	depth 725 mm		205 37			205 37		205 37	
L-shaped separation kit for horizontal busbars 4000 A max.	depth 725 mm		205 38			205 38		205 38	
U-shaped separation kit for horizontal busbars 4000 A max.	depth 975 mm		205 39			205 39		205 39	
U-shaped separation kit for horizontal busbars 1600 A max.	internal cable sleeves depth 475 mm		208 70			208 70		208 70	
	internal cable sleeves depth 725 mm		208 71			208 71		208 71	
U-shaped separation kit for horizontal busbars 4000 A max.	internal cable sleeves depth 725 mm		208 72			208 72		208 72	
	internal cable sleeves depth 975 mm		208 76			208 76		208 76	

Forms equipment selection (continued)

Designation	Complementary information	Forms of separation and type of connection (terminals)							
		2a	2b		3a	3b		4a	4b
		rear terminal	front terminal	rear terminal	rear terminal	front terminal	rear terminal	front terminal	rear terminal
U-shaped separation kit for horizontal busbars 1600 A max.	external cable sleeves depth 475 mm		208 73			208 73		208 73	
	external cable sleeves depth 725 mm		208 74			208 74		208 74	
U-shaped separation kit for horizontal busbars 4000 A max.	external cable sleeves depth 725 mm		208 75			208 75		208 75	
	external cable sleeves depth 975 mm		208 86			208 86		208 86	
Side vertical divider for DPX 1600			205 96			205 96		205 96	
Side partition with and caps for functional units separation	height 200 mm					205 97		205 97	
	height 300 mm					205 98		205 98	
	height 400 mm					205 99		205 99	
Vertical separation for rear busbars	depth 725 mm			208 48			208 48		
	depth 975 mm			208 49			208 49		
Separation for rear busbars	height 200 mm			208 77			208 77		
	height 300 mm			208 78			208 78		
	height 400 mm			208 79			208 79		
Horizontal busbar separation	depth 725 mm			208 93			208 93		
	depth 975 mm			208 94			208 94		208 94
Rear vertical separation						208 69		208 69	
DPX compartment kit	height 200 mm								208 87
	height 300 mm								208 88
	height 400 mm								208 89
Separation for cell without horizontal busbars	to close last DPX compartment								208 95
Bottom busbar area closure									208 96
Rear separation divider for space compartment									208 97
DMX ³ , DMX ³ -I 2500 compartment kit	width 24 modules		208 18	208 18		208 18	208 18	208 18	208 18
DMX ³ , DMX ³ -I 4000, DMX ³ -L compartment kit	width 36 modules		208 19	208 19		208 19	208 19	208 19	208 19

POWER GUIDE: A complete set of technical documentation



01 | Sustainable development



08 | Protection against external disturbances



02 | Power balance and choice of power supply solutions



09 | Operating functions



03 | Electrical energy supply



10 | Enclosures and assembly certification



04 | Sizing conductors and selecting protection devices

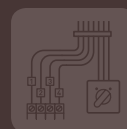

11 | Cabling components and control auxiliaries



05 | Breaking and protection devices

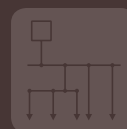

12 | Busbars and distribution



06 | Electrical hazards and protecting people



13 | Transport and distribution inside an installation



07 | Protection against lightning effects



Annexes
Glossary
Lexicon



**World Headquarters and
International Department**
87045 Limoges Cedex - France

☎ : + 33 (0) 5 55 06 87 87
Fax : + 33 (0) 5 55 06 74 55