

Power factor correction: a guide for the plant engineer

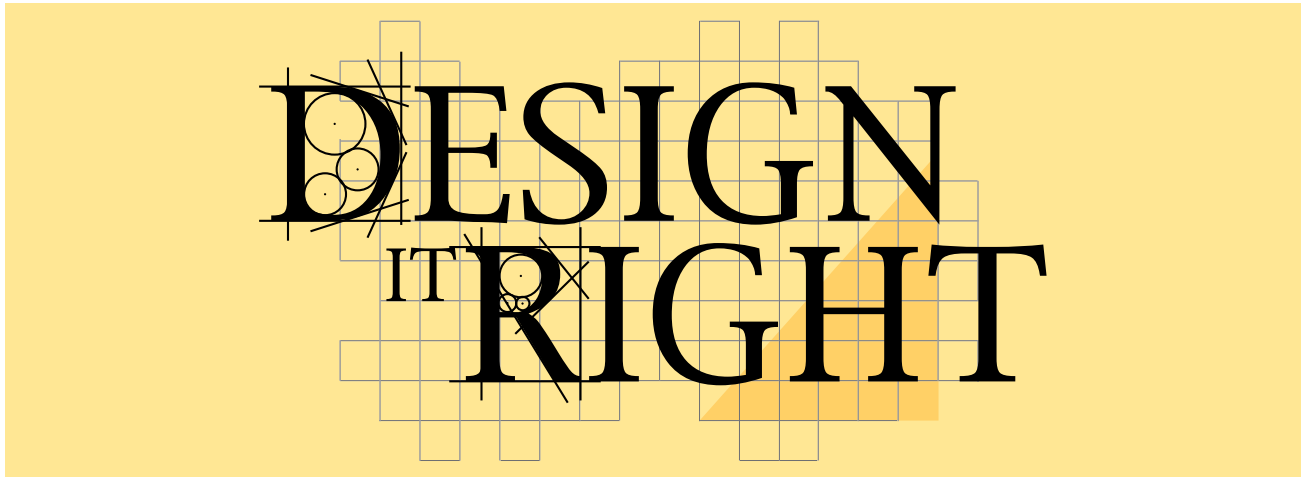

Contents

Description	Page	Description	Page
Part one: power factor		Part two: harmonics	
What is power factor?	2	Introduction	19
Should I be concerned about low power factor?	3	What are harmonics?	19
What can I do to improve power factor?	4	What are the consequences of high harmonic distortion levels?	20
How much can I save by installing power capacitors?	5	IEEE® 519	20
How can I select the right capacitors for my specific application needs?	9	How are harmonics generated?	21
How much kVAR do I need?	9	What do power factor correction capacitors have to do with harmonics?	22
Where should I install capacitors in my plant distribution system?	15	How do I diagnose a potential harmonics-related problem?	22
Can capacitors be used in nonlinear, nonsinusoidal environments?	17	How can harmonics problems be eliminated?	22
What about maintenance?	17	What is a passive harmonic filter?	22
Code requirements for capacitors	17	Do I need to perform a system analysis to correctly apply harmonic filters?	23
Useful capacitor formulas	18	What is Eaton's experience in harmonic filtering?	23



Powering Business Worldwide

Part One: power factor

What is power factor?

Special electrical requirement of inductive loads

Most loads in modern electrical distribution systems are inductive. Examples include motors, transformers, gaseous tube lighting ballasts, and induction furnaces. Inductive loads need a magnetic field to operate.

Inductive loads require two kinds of current:

- Working power (kW) to perform the actual work of creating heat, light, motion, machine output, and so on.
- Reactive power (kVAR) to sustain the magnetic field

Working power consumes watts and can be read on a wattmeter. It is measured in kilowatts (kW). Reactive power doesn't perform useful "work," but circulates between the generator and the load. It places a heavier drain on the power source, as well as on the power source's distribution system. Reactive power is measured in kilovolt-amperes-reactive (kVAR).

Working power and reactive power together make up apparent power. Apparent power is measured in kilovolt-amperes (kVA).

Note: For a discussion on power factor in nonlinear, nonsinusoidal systems, turn to **Page 17**.

Fundamentals of power factor

Power factor is the ratio of working power to apparent power. It measures how effectively electrical power is being used. A high power factor signals efficient utilization of electrical power, while a low power factor indicates poor utilization of electrical power.

To determine power factor (PF), divide working power (kW) by apparent power (kVA). In a linear or sinusoidal system, the result is also referred to as the cosine θ .

$$PF = \frac{kW}{kVA} = \cosine \theta$$

For example, if you had a boring mill that was operating at 100 kW and the apparent power consumed was 125 kVA, you would divide 100 by 125 and come up with a power factor of 0.80.

$$\frac{(kW) 100}{(kVA) 125} = (PF) 0.80$$

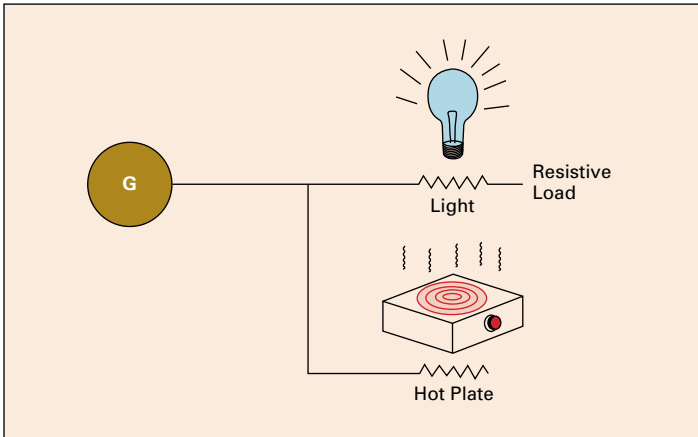

Figure 1. kW Power

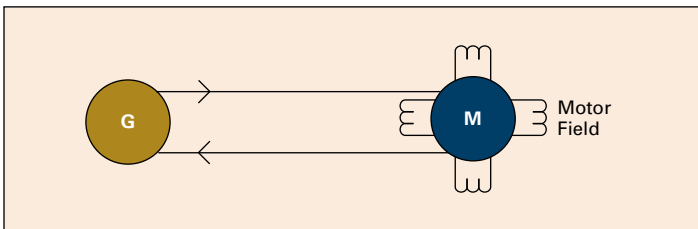

Figure 2. kVAR Power

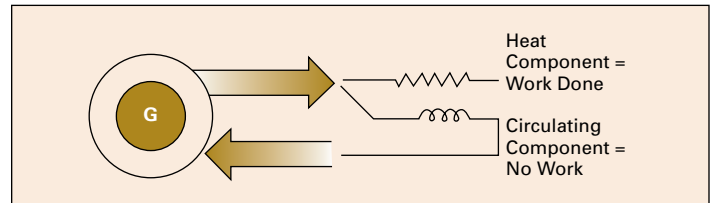

Figure 3. kVA Power

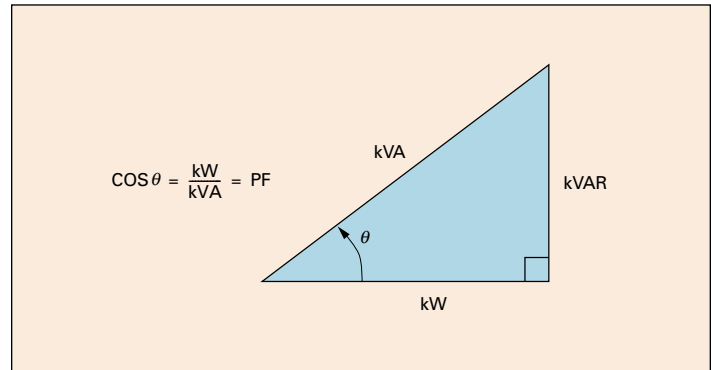

Figure 4. Power Triangle

Note: A right power triangle is often used to illustrate the relationship between kW, kVAR, and kVA.

Should I be concerned about low power factor?

Low power factor means you're not fully utilizing the electrical power you're paying for.

As the triangle relationships in **Figure 5** demonstrate, kVA decreases as power factor increases. At 70% power factor, it requires 142 kVA to produce 100 kW. At 95% power factor, it requires only 105 kVA to produce 100 kW. Another way to look at it is that at 70% power factor, it takes 35% more current to do the same work.

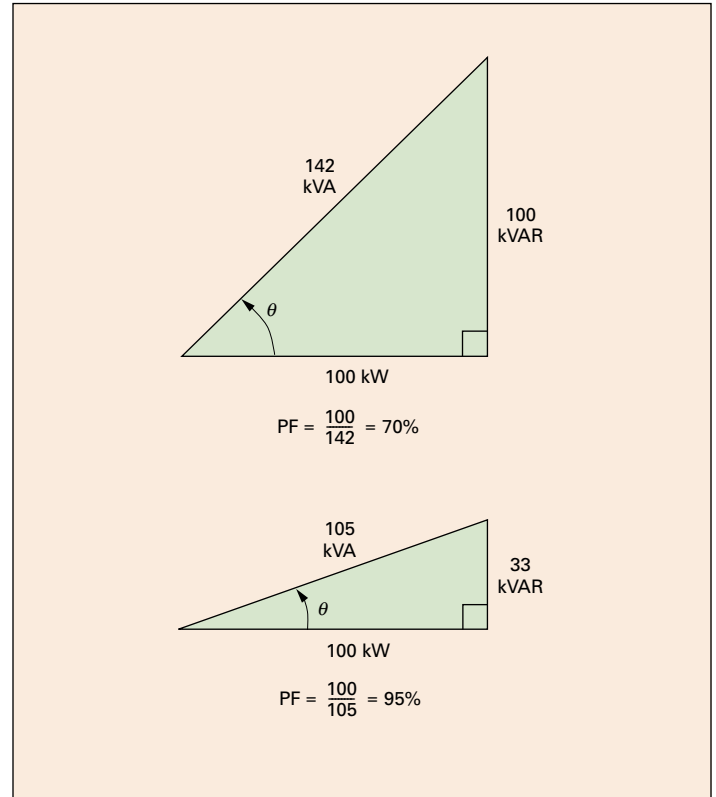

Figure 5. Typical Power Triangles

What can I do to improve power factor?

You can improve power factor by adding power factor correction capacitors to your plant distribution system.

When apparent power (kVA) is greater than working power (kW), the utility must supply the excess reactive current plus the working current. Power capacitors act as reactive current generators. (See **Figure 6.**) By providing the reactive current, they reduce the total amount of current your system must draw from the utility.

95% power factor provides maximum benefit

Theoretically, capacitors could provide 100% of needed reactive power. In practical usage, however, *power factor correction to approximately 95% provides maximum benefit.*

The power triangle in **Figure 7** shows apparent power demands on a system before and after adding capacitors. By installing power capacitors and increasing power factor to 95%, apparent power is reduced from 142 kVA to 105 kVA—a reduction of 35%.

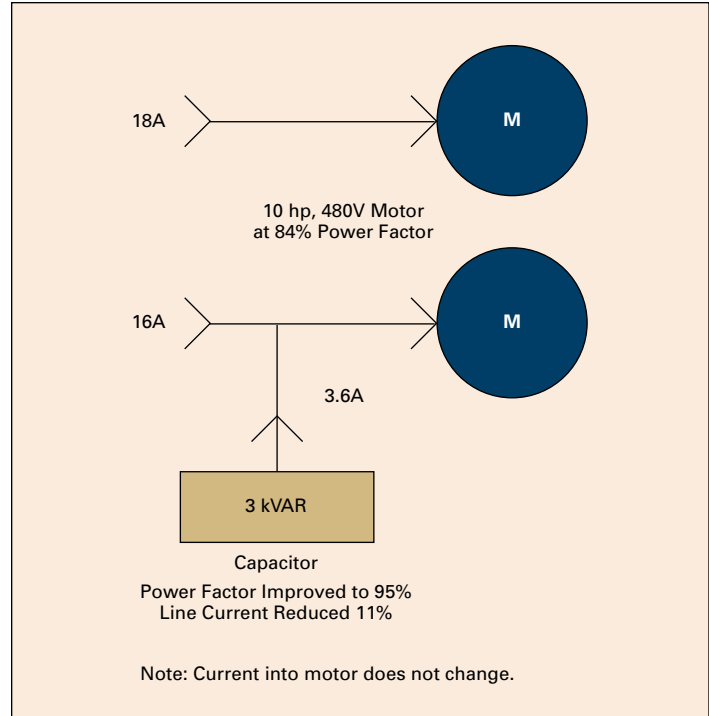

Figure 6. Capacitors as kVAR Generators

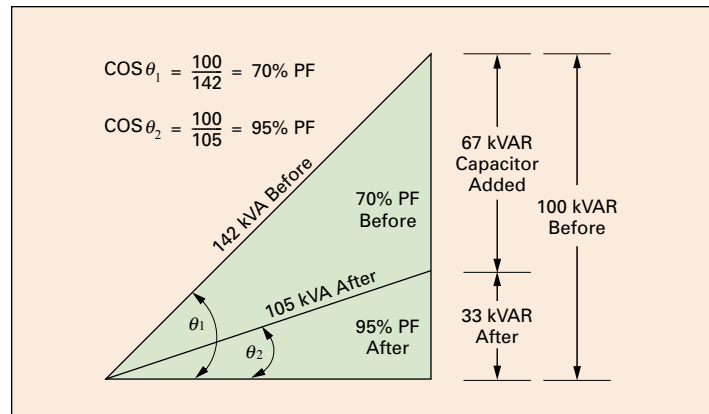

Figure 7. Required Apparent Power Before and After Adding Capacitors

How much can I save by installing power capacitors?

Power capacitors provide many benefits:

- Reduced electric utility bills
- Increased system capacity
- Improved voltage
- Reduced losses

Reduced utility bills

Your electric utility provides working (kW) and reactive power (kVAR) to your plant in the form of apparent power (kVA). While reactive power (kVAR) doesn't register on kW demand or kW hour meters, the utility's transmission and distribution system must be large enough to provide the total power. Utilities have various ways of passing the expense of larger generators, transformers, cables, switches, and the like, along to you.

As shown in the following case histories, capacitors can save you money no matter how your utility bills you for power.

kVA billing

The utility measures and bills every ampere of current, including reactive current.

Case 1

Assume an uncorrected 460 kVA demand, 480V, three-phase at 0.87 power factor (normally good).

Billing:

\$4.75/kVA demand
Correct to 0.97 power factor

Solution:

kVA × power factor = kW
460 × 0.87 = 400 kW actual demand

$$\frac{\text{kW}}{\text{PF}} = \text{kVA}$$

$$\frac{400}{0.97} = 412 \text{ corrected billing demand}$$

From **Table 6** kW multipliers, to raise the power factor from 0.87 to 0.97 requires capacitor:

Multiplier of 0.316 × kW
0.316 × 400 = 126 kVAR (use 140 kVAR)

Uncorrected original billing:

460 kVA × \$4.75 = \$2185 / month

$$\begin{array}{r} -\$1957 \\ \hline \$ 228 / \text{month savings} \times 12 \\ \$2736 \text{ annual savings} \end{array}$$

Corrected new billing:

412 kVA × \$4.75 = \$1957/month
 140 kVAR, 480V capacitor cost: \$1600 (installation extra).
 This capacitor pays for itself in less than eight months.

Case 2

Assume the same conditions except that:
 400 kW @ 87% = 460 kVA
 400 kW @ 97% = 412 kVA corrected billing

kVA demand charge:

\$1.91 / kVA / month (112,400 kWh / month energy consumed)

Energy charge:

\$0.0286 / kWh (first 200 kWh / kVA of demand)
 \$0.0243 / kWh (next 300 kWh / kVA of demand)
 \$0.021 / kWh (all over 500 kWh / kVA of demand)

Uncorrected:

460 kVA × \$1.91 = \$878.60

$$\begin{array}{r} -\$786.92 \\ \hline \$ 91.68 \text{ savings in demand charge} \end{array}$$

Corrected:

412 kVA × \$1.91 = \$786.92

Uncorrected energy:

kWh = 112,400
 460 × 200 = 92,000 kWh
 @ 0.0286 = \$2631.20

460 × 300 = 138,000
 but balance only = 20,400
 @ \$0.0243 = \$495.72

\$2631.20
 + \$ 495.72
 \$3126.92 uncorrected energy charge

Corrected energy:

kWh = 112,400
 460 × 200 = 82,400 kWh
 @ 0.0286 = \$2356.64

460 × 300 = 123,600
 but balance only = 30,000
 @ \$0.0243 = \$729.00

\$2356.64
 + \$ 729.00
 \$3085.64 corrected energy charge

\$3126.92

$$\begin{array}{r} -\$3085.64 \\ \hline \$ 41.28 \text{ savings in energy charge due to rate charge} \end{array}$$

(9600 kWh in first step reduced by \$0.0043)

This is not a reduction in energy consumed, but in billing only.

\$ 41.28 energy

$$\begin{array}{r} -\$ 91.68 \text{ demand} \\ \hline \$ 132.96 \text{ monthly total savings} \end{array}$$

 × $\frac{12}{1}$
 \$1595.52

A 130 kVAR capacitor can be paid for in less than 14 months.

kW demand billing with power factor adjustment

The utility charges according to the kW demand and adds a surcharge or adjustment for power factor. The adjustment may be a multiplier applied to kW demand. The following formula shows a billing based on 90% power factor:

$$\frac{\text{kW demand} \times 0.90}{\text{actual power factor}}$$

If power factor was 0.84, the utility would require 7% increase in billing, as shown in this formula:

$$\frac{\text{kW} \times 0.90}{0.84} = 107 \text{ (multiplier)}$$

Some utilities charge for low power factor but give a credit or bonus for power above a certain level.

Case 1

Assume a 400 kW load, 87% power factor with the following utility tariff.

Demand charges:

- First 40 kW @ \$10.00 / kW monthly billing demand
- Next 160 kW @ \$ 9.50 / kW
- Next 800 kW @ \$ 9.00 / kW
- All over 1000 kW @ \$ 8.50 / kW

Power factor clause:

Rates based on power factor of 90% or higher. When power factor is less than 85%, the demand will be increased 1% for each 1% that the power factor is below 90%. If the power factor is higher than 95%, the demand will be decreased 1% for each 1% that the power factor is above 90%.

There would be no penalty for 87% power factor. However, a bonus could be credited if the power factor were raised to 96%.

To raise an 87% power factor to 96%, refer to **Table 6**. Find 0.275 x 400 kW = 110 kVAR. (Select 120 kVAR to ensure the maintenance of the 96% level.)

To calculate savings:

Normal 400 kW billing demand	
First 40 kW @ \$10.00 = \$ 400.00	
Next 160 kW @ \$ 9.50 = \$1520.00	
Bal. 200 kW @ \$ 9.00 = \$1800.00	
Total 400 kW	\$3720.00 normal monthly billing

New billing:

$$\frac{\text{kW} \times 0.90}{\text{New power factor}} = \frac{400 \times 0.90}{0.96} = 375 \text{ kW demand}$$

First 40 kW @ \$10.00 = \$ 400.00	
Next 160 kW @ \$ 9.50 = \$1520.00	
Bal. 175 kW @ \$ 9.00 = \$1575.00	
	\$3495.00 power factor adjusted billing

Case 2

With the same 400 kW load, the power factor is only 81%. In this example, the customer will pay an adjustment on:

$$\frac{400 \times 0.90}{0.81} = 444 \text{ billing kW demand}$$

(From Case 1: When the power factor = 96%, the billing demand is 375 kW = \$3495.00 per month.)

First 40 kW @ \$10.00 = \$ 400.00	
Next 160 kW @ \$ 9.50 = \$1520.00	
Next 244 kW @ \$ 9.00 = \$2196.00	
Total 444 kW	\$4116.00 - \$3495.00 = \$621.00 x 12 = \$7452.00

Yearly savings if corrected to 96%.

\$4116.00 Charge at 81%	
- \$3720.00 Normal kW demand charge	
\$ 395.00 Power factor adjustment for 81% power factor	●

To raise 81% power factor to 96%, select the multiplier from **Table 6**. 0.432 x 400 kW = 173 kVAR. Use 180 kVAR to ensure a 96% power factor. The cost of a 180 kVAR capacitor is \$1900.00, and the payoff is less than four months.

● 55 kVAR would eliminate the penalty by correcting power factor to 85%.

kVAR reactive demand charge

The utility imposes a direct charge for the use of magnetizing power, usually a waiver of some percentage of kW demand. For example, if this charge were 60 cents per kVAR for everything over 50% of kW, and a 400 kW load existed at the time, the utility would provide 200 kVAR free.

Case 1

Assume a 400 kW load demand at 81% power factor.

Tariff structure:

Demand charge is:

\$635.00 for the first 200 kW demand
\$ 2.80 per kW for all addition

Reactive demand charge is:

\$ 0.60 per kVAR in excess of 50% of kW demand

In this example, kW demand = 400 kW,
therefore 50% = 200 kVAR which will be furnished at no cost.

$$\cos \theta = PF = \frac{kW}{kVA} \text{ or } \frac{Adj}{Hyp}$$

$$\tan \theta = \frac{kvar}{kW} \text{ or } \frac{Opp}{Adj}$$

This ratio is the basis for the table of Multipliers (See **Table 5**).

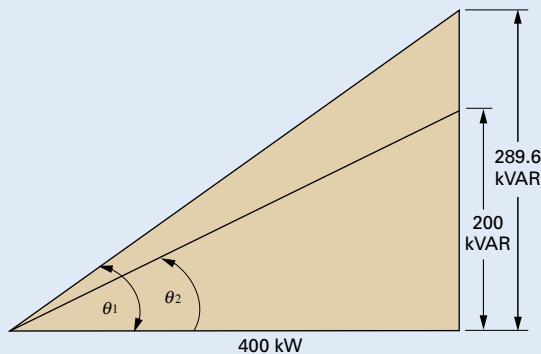

With 200 kVAR allowed at no cost, then

$$\theta_2 = \frac{200}{400} \text{ 0.5 or 50% of kW}$$

From 1.0 or unity power factor column, **Table 6**, note that 0.500 falls between 89% and 90% power factor. The billing excess kVAR is above that level 81% power factor.

$$\tan \theta_1 = 0.724 \text{ kVAR} = kW \times \tan \theta_1 = 400 \times 0.724 = 289.6 \text{ kVAR}$$

Because 200 kVAR is allowed, the excess kVAR is 89.6 (round to 90) x \$0.60 = \$54.00 per month billing for reactive demand.

Solution:

To correct 400 kW from 81% to 90% requires 400 x 0.240 (from **Table 6**) = 96 kVAR. (Use 100 kVAR.) The approximate cost for this capacitor is \$1250.00. The payoff is about 23 months.

Charges for kVAR vary from about 15 cents to a dollar, and free kVAR ranges from 25% (97% power factor) to 75% (80% power factor) of kW demand.

Increased system capacity

Power factor correction capacitors increase system current-carrying capacity. Raising the power factor on a kW load reduces kVA. Therefore, by adding capacitors, you can add additional kW load to your system without altering the kVA.

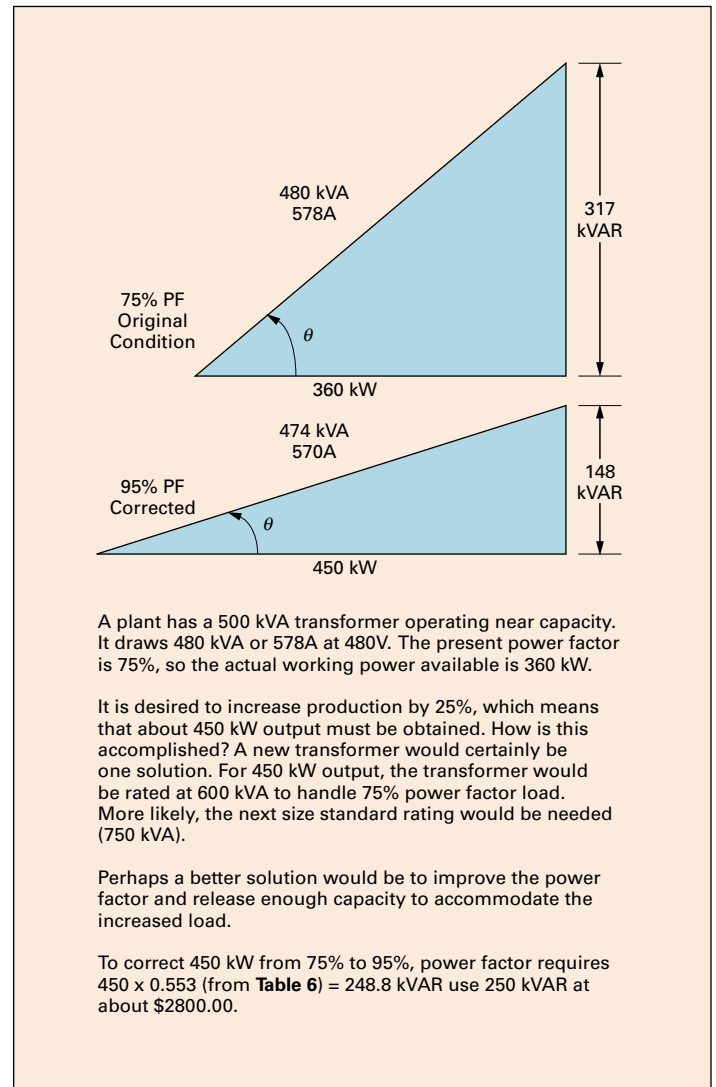

Figure 8. Correcting Power Factor Increases Transformer Output

The same principle holds true for reducing current on overloaded facilities. Increasing power factor from 75% to 95% on the same kW load results in 21% lower current flow. Put another way, it takes 26.7% more current for a load to operate at 75%, and 46.2% more current to operate at 65%.

Industries with low power factor benefit most from capacitors

Low power factor results when inactive motors are operated at less than full load. This often occurs in cycle processes—such as those using circular saws, ball mills, conveyors, compressors, grinders, punch presses, and the like—where motors are sized for the heaviest load. Examples of situations where low power factor (from 30% to 50%) occur include a surface grinder performing a light cut, an unloaded air compressor, and a circular saw spinning without cutting.

The following industries typically exhibit low power factors:

Table 1. Typical Low Power Factor Industries

Industry	Uncorrected Power Factor
Saw mills	45%–60%
Plastic (especially extruders)	55%–70%
Machine tools, stamping	60%–70%
Plating, textiles, chemicals, breweries	65%–75%
Hospitals, granaries, foundries	70%–80%

Include power capacitors in new construction and expansion plans

Including power capacitors in your new construction and expansion plans can reduce the size of transformers, bus, switches, and the like, and bring your project in at lower cost.

Figure 9 shows how much system kVA can be released by improving power factor. Raising the power factor from 70% to 90% releases 0.32 kVA per kW. On a 400 kW load, 128 kVA is released.

Improved voltage conditions

Low voltage, resulting from excessive current draw, causes motors to be sluggish and overheated. As power factor decreases, total line current increases, causing further voltage drop. By adding capacitors to your system and improving voltage, you get more efficient motor performance and longer motor life.

Reduced losses

Losses caused by poor power factor are due to reactive current flowing in the system. These are watt-related charges and can be eliminated through power factor correction. Power loss (watts) in a distribution system is calculated by squaring the current and multiplying it by the circuit resistance (12R). To calculate loss reduction:

$$\% \text{ reduction losses} = 100 - 100 \times \left(\frac{\text{original power factor}}{\text{new power factor}} \right)^2$$

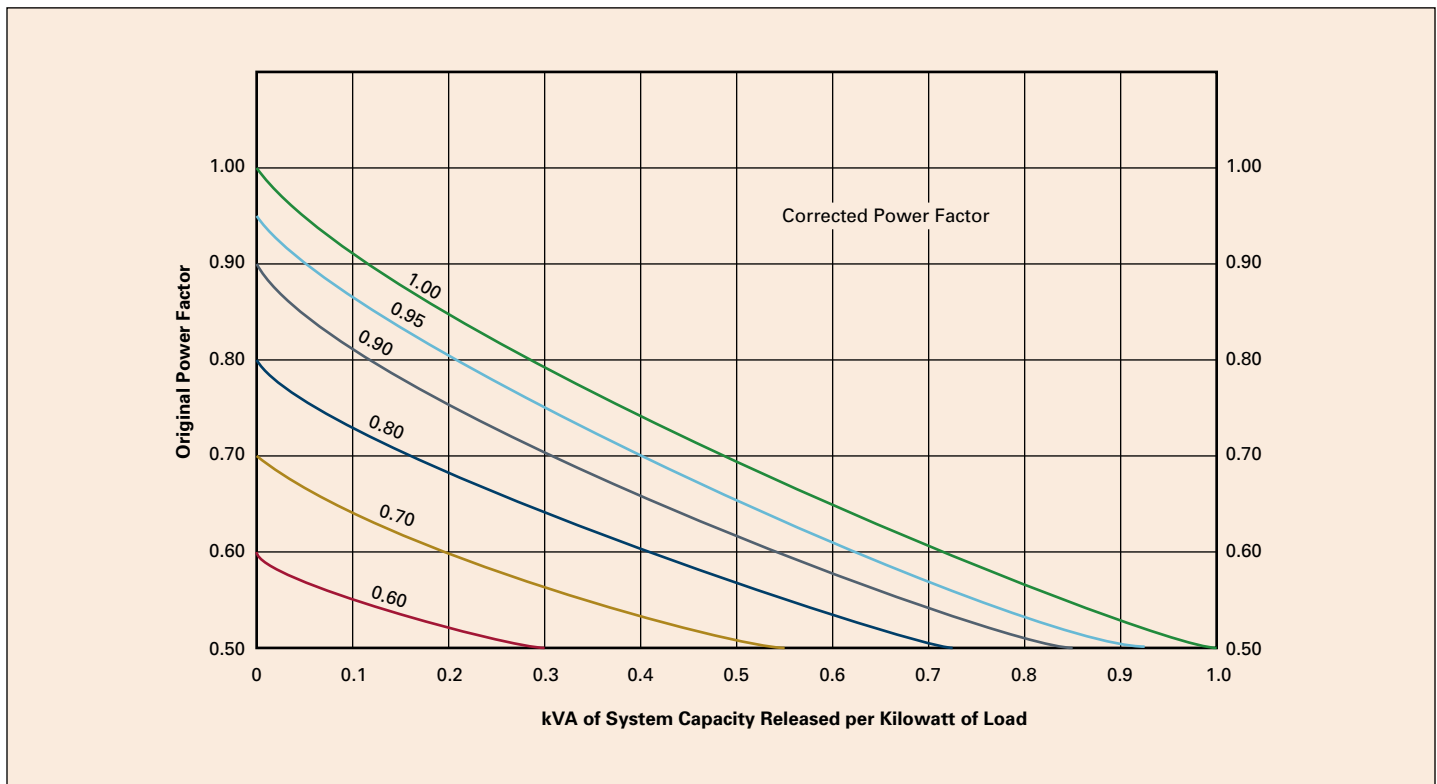

Figure 9. Corrected Power Factor Releases System kVA

How can I select the right capacitors for my specific application needs?

Once you've decided that your facility can benefit from power factor correction, you'll need to choose the optimum type, size, and number of capacitors for your plant.

There are two basic types of capacitor installations: individual capacitors on linear or sinusoidal loads, and banks of fixed or automatically switched capacitors at the feeder or substation.

Individual vs. banked installations

Advantages of individual capacitors at the load:

- Complete control; capacitors cannot cause problems on the line during light load conditions
- No need for separate switching; motor always operates with capacitor
- Improved motor performance due to more efficient power use and reduced voltage drops
- Motors and capacitors can be easily relocated together
- Easier to select the right capacitor for the load
- Reduced line losses
- Increased system capacity

Advantages of bank installations at the feeder or substation:

- Lower cost per kVAR
- Total plant power factor improved—reduces or eliminates all forms of kVAR charges
- Automatic switching ensures exact amount of power factor correction, eliminates over-capacitance and resulting overvoltages

Table 2. Summary of Advantages/Disadvantages of Individual, Fixed Banks, Automatic Banks, Combination

Method	Advantages	Disadvantages
Individual capacitors	Most technically efficient, most flexible	Higher installation and maintenance cost
Fixed bank	Most economical, fewer installations	Less flexible, requires switches and/or circuit breakers
Automatic bank	Best for variable loads, prevents overvoltages, low installation cost	Higher equipment cost
Combination	Most practical for larger numbers of motors	Least flexible

Consider the particular needs of your plant

When deciding which type of capacitor installation best meets your needs, you'll have to weigh the advantages and disadvantages of each and consider several plant variables, including load type, load size, load constancy, load capacity, motor starting methods, and manner of utility billing.

Load type

If your plant has many large motors, 50 hp and above, it is usually economical to install one capacitor per motor and switch the capacitor and motor together. If your plant consists of many small motors, 1/2 to 25 hp, you can group the motors and install one capacitor at a central point in the distribution system. Often, the best solution for plants with large and small motors is to use both types of capacitor installations.

Load size

Facilities with large loads benefit from a combination of individual load, group load, and banks of fixed and automatically-switched capacitor units. A small facility, on the other hand, may require only one capacitor at the control board.

Sometimes, only an isolated trouble spot requires power factor correction. This may be the case if your plant has welding machines, induction heaters, or DC drives. If a particular feeder serving a low power factor load is corrected, it may raise overall plant power factor enough that additional capacitors are unnecessary.

Load constancy

If your facility operates around the clock and has a constant load demand, fixed capacitors offer the greatest economy. If load is determined by eight-hour shifts five days a week, you'll want more switched units to decrease capacitance during times of reduced load.

Load capacity

If your feeders or transformers are overloaded, or if you wish to add additional load to already loaded lines, correction must be applied at the load. If your facility has surplus amperage, you can install capacitor banks at main feeders. If load varies a great deal, automatic switching is probably the answer.

Utility billing

The severity of the local electric utility tariff for power factor will affect your payback and ROI. In many areas, an optimally designed power factor correction system will pay for itself in less than two years.

How much kVAR do I need?

The unit for rating power factor capacitors is a kVAR, equal to 1000 volt-amperes of reactive power. The kVAR rating signifies how much reactive power the capacitor will provide.

Sizing capacitors for individual motor loads

To size capacitors for individual motor loads, use **Table 3** on the following page. Simply look up the type of motor frame, RPM, and horsepower. The charts indicate the kVAR rating you need to bring power factor to 95%. The charts also indicate how much current is reduced when capacitors are installed.

Sizing capacitors for entire plant loads

If you know the total kW consumption of your plant, its present power factor, and the power factor you're aiming for, you can use **Table 6**, on **Page 13** to select capacitors.

Table 3. Suggested Maximum Capacitor Ratings

Induction Motor hp Rating	Number of Poles and Nominal Motor Speed in RPM														
	2-3600 RPM			4-1800 RPM			6-1200 RPM			8-900 RPM			10-720 RPM		12-600 RPM
Capacitor kVAR	Current Reduction %	Capacitor kVAR	Current Reduction %	Capacitor kVAR	Current Reduction %	Capacitor kVAR	Current Reduction %	Capacitor kVAR	Current Reduction %	Capacitor kVAR	Current Reduction %	Capacitor kVAR	Current Reduction %		
Used for High-Efficiency Motors and Older Design (Pre "T-Frame") Motors ①															
3	1.5	14	1.5	15	1.5	20	2	27	2.5	35	3	41			
5	2	12	2	13	2	17	3	25	4	32	4	37			
7.5	2.5	11	2.5	12	3	15	4	22	5	30	6	34			
10	3	10	3	11	3	14	5	21	6	27	7.5	31			
15	4	9	4	10	5	13	6	18	8	23	9	27			
20	5	9	5	10	6	12	7.5	16	9	21	12.5	25			
25	6	9	6	10	7.5	11	9	15	10	20	15	23			
30	7	8	7	9	9	11	10	14	12.5	18	17.5	22			
40	9	8	9	9	10	10	12.5	13	15	16	20	20			
50	12.5	8	10	9	12.5	10	15	12	20	15	25	19			
60	15	8	15	8	15	10	17.5	11	22.5	15	27.5	19			
75	17.5	8	17.5	8	17.5	10	20	10	25	14	35	18			
100	22.5	8	20	8	25	9	27.5	10	35	13	40	17			
125	27.5	8	25	8	30	9	30	10	40	13	50	16			
150	30	8	30	8	35	9	37.5	10	50	12	50	15			
200	40	8	37.5	8	40	9	50	10	60	12	60	14			
250	50	8	45	7	50	8	60	9	70	11	75	13			
300	60	8	50	7	60	8	60	9	80	11	90	12			
350	60	8	60	7	75	8	75	9	90	10	95	11			
400	75	8	60	6	75	8	85	9	95	10	100	11			
450	75	8	75	6	80	8	90	9	100	9	110	11			
500	75	8	75	6	85	8	100	9	100	9	120	10			
"T-Frame" NEMA® "Design B" Motors ①															
2	1	14	1	24	1.5	30	2	42	2	40	3	50			
3	1.5	14	1.5	23	2	28	3	38	3	40	4	49			
5	2	14	2.5	22	3	26	4	31	4	40	5	49			
7.5	2.5	14	3	20	4	21	5	28	5	38	6	45			
10	4	14	4	18	5	21	6	27	7.5	36	8	38			
15	5	12	5	18	6	20	7.5	24	8	32	10	34			
20	6	12	6	17	7.5	19	9	23	10	29	12.5	30			
25	7.5	12	7.5	17	8	19	10	23	12.5	25	17.5	30			
30	8	11	8	16	10	19	15	22	15	24	20	30			
40	12.5	12	15	16	15	19	17.5	21	20	24	25	30			
50	15	12	17.5	15	20	19	22.5	21	22.5	24	30	30			
60	17.5	12	20	15	22.5	17	25	20	30	22	35	28			
75	20	12	25	14	25	15	30	17	35	21	40	19			
100	22.5	11	30	14	30	12	35	16	40	15	45	17			
125	25	10	35	12	35	12	40	14	45	15	50	17			
150	30	10	40	12	40	12	50	14	50	13	60	17			
200	35	10	50	11	50	11	70	14	70	13	90	17			
250	40	11	60	10	60	10	80	13	90	13	100	17			
300	45	11	70	10	75	12	100	14	100	13	120	17			
350	50	12	75	8	90	12	120	13	120	13	135	15			
400	75	10	80	8	100	12	130	13	140	13	150	15			
450	80	8	90	8	120	10	140	12	160	14	160	15			
500	100	8	120	9	150	12	160	12	180	13	180	15			

① For use with three-phase, 60 Hz NEMA Classification B Motors to raise full load power factor to approximately 95%.

Table 4. Suggested Capacitor Ratings, in kVARs, for NEMA Design C and D, and Wound-Rotor Motors

Induction Motor Rating (hp)	Design C Motor		Design D Motor	Wound-Rotor Motor
	1800 and 1200 r/Minimum	900 r/Minimum	1200 r/Minimum	
15	5	5	5	5.5
20	5	6	6	7
25	6	6	6	7
30	7.5	9	10	11
40	10	12	12	13
50	12	15	15	17.5
60	17.5	18	18	20
75	19	22.5	22.5	25
100	27	27	30	33
125	35	37.5	37.5	40
150	37.5	45	45	50
200	45	60	60	65
250	54	70	70	75
300	65	90	75	85

Note: Applies to three-phase, 60 Hz motors when switched with capacitors as single unit.

Note: Use motor manufacturer's recommended kVAR as published in the performance data sheets for specific motor types: drip-proof, TEFC, severe duty, high-efficiency, and NEMA design.

Table 5. Suggested Capacitor Ratings for Medium Voltage Motors

Induction Motor hp Rating	Number of Poles and Nominal Motor Speed in RPM												
	2-3600 RPM		4-1800 RPM		6-1200 RPM		8-900 RPM		10-720 RPM		12-600 RPM		
Capacitor kVAR	Current Reduction %	Capacitor kVAR	Current Reduction %	Capacitor kVAR	Current Reduction %	Capacitor kVAR	Current Reduction %	Capacitor kVAR	Current Reduction %	Capacitor kVAR	Current Reduction %	Capacitor kVAR	Current Reduction %
2400 and 4160V—Open													
100	25	8	25	10	25	11	25	11	25	12	25	15	15
125	25	7	25	9	25	10	25	10	25	11	50	15	15
150	25	7	25	8	25	9	25	9	25	11	50	14	14
200	50	7	50	8	50	9	50	9	50	10	75	14	14
250	50	7	50	7	50	8	75	9	75	10	75	14	14
300	50	7	50	7	75	8	75	9	75	9	100	13	13
350	50	6	50	6	75	8	75	9	75	9	100	12	12
400	75	6	75	6	75	7	100	9	100	9	100	11	11
450	75	6	75	6	75	6	100	9	100	9	125	10	10
500	75	5	75	6	100	6	125	9	125	9	125	9	9
600	75	5	100	6	100	6	125	8	150	9	150	9	9
700	100	5	100	6	125	6	150	8	150	8	150	8	8
800	100	5	150	6	150	6	150	7	200	8	200	8	8
900	125	5	150	6	200	6	200	7	250	8	250	8	8
1000	150	5	200	6	250	5	250	6	250	7	250	7	7
1250	200	5	200	5	250	5	300	6	300	6	300	6	6
2400 and 4160V—Totally Enclosed Fan Cooled													
100	25	7	25	8	25	9	25	11	25	11	25	13	13
125	25	7	25	7	25	8	25	11	25	11	50	13	13
150	25	6	25	7	25	8	50	11	50	11	50	13	13
200	50	6	50	7	50	8	50	11	50	11	75	13	13
250	50	6	50	7	50	8	75	11	75	11	75	13	13
300	50	6	50	7	75	8	75	10	100	11	100	13	13
350	75	6	75	7	100	8	100	10	100	11	125	13	13
400	75	6	75	7	100	8	100	10	100	11	150	13	13
450	75	6	100	7	100	8	125	10	125	11	150	13	13
500	100	5	125	7	125	7	150	10	150	11	150	13	13

Above sizes are intended to provide a corrected power factor of approximately 95% at full load. Because of the limited number of capacitor ratings available, it is not possible to raise every motor PF to 95%.

To calculate kVAR required to correct power factor to a specific target value, use the following formula:

$$kVAR_{(required)} = \frac{hp \times 0.746}{\% EFF} \left(\frac{\sqrt{1 - PFa^2}}{PFa} - \frac{\sqrt{1 - PFt^2}}{PFt} \right)$$

Where

- hp: motor nameplate horsepower
- %EFF: motor nameplate efficiency (enter the value in decimal)
- PFa: motor nameplate actual power factor
- PFt: target power factor

Note: Consult the motor manufacturer’s data sheet to verify the maximum kVAR of capacitors that can be directly connected at motor terminals. To avoid self-excitation, do not exceed the maximum kVAR rating that is specified by the motor manufacturer.

Instructions for Table 6 on Page 13:

1. Find the present power factor in column one.
2. Read across to optimum power factor column.
3. Multiply that number by kW demand.

Example:

If your plant consumes 410 kW, is currently operating at 73% power factor, and you want to correct power factor to 95%, you would:

1. Find 0.73 in column one.
2. Read across to 0.95 column.
3. Multiply 0.607 by 410 = 249 (round to 250).
4. You need 250 kVAR to bring your plant to 95% power factor.

If you don’t know the existing power factor level of your plant, you will have to calculate it before using **Table 6** on the following page. To calculate existing power factor: kW divided by kVA = power factor.

Table 6. Multipliers to Determine Capacitor Kilovars Required for Power Factor Correction

Original Power Factor	Corrected Power Factor																				
	0.8	0.81	0.82	0.83	0.84	0.85	0.86	0.87	0.88	0.89	0.9	0.91	0.92	0.93	0.94	0.95	0.96	0.97	0.98	0.99	1.0
0.50	0.982	1.008	1.034	1.060	1.086	1.112	1.139	1.165	1.192	1.220	1.248	1.276	1.306	1.337	1.369	1.403	1.440	1.481	1.529	1.589	1.732
0.51	0.937	0.962	0.989	1.015	1.041	1.067	1.094	1.120	1.147	1.175	1.203	1.231	1.261	1.292	1.324	1.358	1.395	1.436	1.484	1.544	1.687
0.52	0.893	0.919	0.945	0.971	0.997	1.023	1.050	1.076	1.103	1.131	1.159	1.187	1.217	1.248	1.280	1.314	1.351	1.392	1.440	1.500	1.643
0.53	0.850	0.876	0.902	0.928	0.954	0.980	1.007	1.033	1.060	1.088	1.116	1.144	1.174	1.205	1.237	1.271	1.308	1.349	1.397	1.457	1.600
0.54	0.809	0.835	0.861	0.887	0.913	0.939	0.966	0.992	1.019	1.047	1.075	1.103	1.133	1.164	1.196	1.230	1.267	1.308	1.356	1.416	1.559
0.55	0.769	0.795	0.821	0.847	0.873	0.899	0.926	0.952	0.979	1.007	1.035	1.063	1.093	1.124	1.156	1.190	1.227	1.268	1.316	1.376	1.519
0.56	0.730	0.756	0.782	0.808	0.834	0.860	0.887	0.913	0.940	0.968	0.996	1.024	1.054	1.085	1.117	1.151	1.188	1.229	1.277	1.337	1.480
0.57	0.692	0.718	0.744	0.770	0.796	0.822	0.849	0.875	0.902	0.930	0.958	0.986	1.016	1.047	1.079	1.113	1.150	1.191	1.239	1.299	1.442
0.58	0.655	0.681	0.707	0.733	0.759	0.785	0.812	0.838	0.865	0.893	0.921	0.949	0.979	1.010	1.042	1.076	1.113	1.154	1.202	1.262	1.405
0.59	0.619	0.645	0.671	0.697	0.723	0.749	0.776	0.802	0.829	0.857	0.885	0.913	0.943	0.974	1.006	1.040	1.077	1.118	1.166	1.226	1.369
0.60	0.583	0.609	0.635	0.661	0.687	0.713	0.740	0.766	0.793	0.821	0.849	0.877	0.907	0.938	0.970	1.004	1.041	1.082	1.130	1.190	1.333
0.61	0.549	0.575	0.601	0.627	0.653	0.679	0.706	0.732	0.759	0.787	0.815	0.843	0.873	0.904	0.936	0.970	1.007	1.048	1.096	1.156	1.299
0.62	0.516	0.542	0.568	0.594	0.620	0.646	0.673	0.699	0.726	0.754	0.782	0.810	0.840	0.871	0.903	0.937	0.974	1.015	1.063	1.123	1.266
0.63	0.483	0.509	0.535	0.561	0.587	0.613	0.640	0.666	0.693	0.721	0.749	0.777	0.807	0.838	0.870	0.904	0.941	0.982	1.030	1.090	1.233
0.64	0.451	0.474	0.503	0.529	0.555	0.581	0.608	0.634	0.661	0.689	0.717	0.745	0.775	0.806	0.838	0.872	0.909	0.950	0.998	1.068	1.201
0.65	0.419	0.445	0.471	0.497	0.523	0.549	0.576	0.602	0.629	0.657	0.685	0.713	0.743	0.774	0.806	0.840	0.877	0.918	0.966	1.026	1.169
0.66	0.388	0.414	0.440	0.466	0.492	0.518	0.545	0.571	0.598	0.626	0.654	0.682	0.712	0.743	0.775	0.809	0.846	0.887	0.935	0.995	1.138
0.67	0.358	0.384	0.410	0.436	0.462	0.488	0.515	0.541	0.568	0.596	0.624	0.652	0.682	0.713	0.745	0.779	0.816	0.857	0.905	0.965	1.108
0.68	0.328	0.354	0.380	0.406	0.432	0.458	0.485	0.511	0.538	0.566	0.594	0.622	0.652	0.683	0.715	0.749	0.786	0.827	0.875	0.935	1.078
0.69	0.299	0.325	0.351	0.377	0.403	0.429	0.456	0.482	0.509	0.537	0.565	0.593	0.623	0.654	0.686	0.720	0.757	0.798	0.846	0.906	1.049
0.70	0.270	0.296	0.322	0.348	0.374	0.400	0.427	0.453	0.480	0.508	0.536	0.564	0.594	0.625	0.657	0.691	0.728	0.769	0.817	0.877	1.020
0.71	0.242	0.268	0.294	0.320	0.346	0.372	0.399	0.425	0.452	0.480	0.508	0.536	0.566	0.597	0.629	0.663	0.700	0.741	0.789	0.849	0.992
0.72	0.214	0.240	0.266	0.292	0.318	0.344	0.371	0.397	0.424	0.452	0.480	0.508	0.538	0.569	0.601	0.635	0.672	0.713	0.761	0.821	0.964
0.73	0.186	0.212	0.238	0.264	0.290	0.316	0.343	0.369	0.396	0.424	0.452	0.480	0.510	0.541	0.573	0.607	0.644	0.685	0.733	0.793	0.936
0.74	0.159	0.185	0.211	0.237	0.263	0.289	0.316	0.342	0.369	0.397	0.425	0.453	0.483	0.514	0.546	0.580	0.617	0.658	0.706	0.766	0.909
0.75	0.132	0.158	0.184	0.210	0.236	0.262	0.289	0.315	0.342	0.370	0.398	0.426	0.456	0.487	0.519	0.553	0.590	0.631	0.679	0.739	0.882
0.76	0.105	0.131	0.157	0.183	0.209	0.235	0.262	0.288	0.315	0.343	0.371	0.399	0.429	0.460	0.492	0.526	0.563	0.604	0.652	0.712	0.855
0.77	0.079	0.105	0.131	0.157	0.183	0.209	0.236	0.262	0.289	0.317	0.345	0.373	0.403	0.434	0.466	0.500	0.537	0.578	0.626	0.685	0.829
0.78	0.052	0.078	0.104	0.130	0.156	0.182	0.209	0.235	0.262	0.290	0.318	0.346	0.376	0.407	0.439	0.473	0.510	0.551	0.599	0.659	0.802
0.79	0.026	0.052	0.078	0.104	0.130	0.156	0.183	0.209	0.236	0.264	0.292	0.320	0.350	0.381	0.413	0.447	0.484	0.525	0.573	0.633	0.776
0.80	0.000	0.026	0.052	0.078	0.104	0.130	0.157	0.183	0.210	0.238	0.266	0.294	0.324	0.355	0.387	0.421	0.458	0.499	0.547	0.609	0.750
0.81		0.000	0.026	0.052	0.078	0.104	0.131	0.157	0.184	0.212	0.240	0.268	0.298	0.329	0.361	0.395	0.432	0.473	0.521	0.581	0.724
0.82			0.000	0.026	0.052	0.078	0.105	0.131	0.158	0.186	0.214	0.242	0.272	0.303	0.335	0.369	0.406	0.447	0.495	0.555	0.698
0.83				0.000	0.026	0.052	0.079	0.105	0.132	0.160	0.188	0.216	0.246	0.277	0.309	0.343	0.380	0.421	0.469	0.529	0.672
0.84					0.000	0.026	0.053	0.079	0.106	0.134	0.162	0.190	0.220	0.251	0.283	0.317	0.354	0.395	0.443	0.503	0.646
0.85						0.000	0.027	0.053	0.080	0.108	0.136	0.164	0.194	0.225	0.257	0.291	0.328	0.369	0.417	0.477	0.620
0.86							0.000	0.026	0.053	0.081	0.109	0.137	0.167	0.198	0.230	0.264	0.301	0.342	0.390	0.450	0.593
0.87								0.000	0.027	0.055	0.083	0.111	0.141	0.172	0.204	0.238	0.275	0.316	0.364	0.424	0.567
0.88									0.000	0.028	0.056	0.084	0.114	0.145	0.177	0.211	0.248	0.289	0.337	0.397	0.540
0.89										0.000	0.028	0.056	0.086	0.117	0.149	0.183	0.220	0.261	0.309	0.369	0.512
0.90											0.000	0.028	0.058	0.089	0.121	0.155	0.192	0.233	0.281	0.341	0.484
0.91												0.000	0.030	0.061	0.093	0.127	0.164	0.205	0.253	0.313	0.456
0.92													0.000	0.031	0.063	0.097	0.134	0.175	0.223	0.283	0.426
0.93														0.000	0.032	0.066	0.103	0.144	0.192	0.252	0.395
0.94															0.000	0.034	0.071	0.112	0.160	0.220	0.363
0.95																0.000	0.037	0.079	0.126	0.186	0.329
0.96																	0.000	0.041	0.089	0.149	0.292
0.97																		0.000	0.048	0.108	0.251
0.98																			0.000	0.060	0.203
0.99																				0.000	0.143
																					0.000

Table 7. Recommended Wire Sizes, Switches, and Fuses for Three-Phase, 60 Hz Capacitors

These wire sizes are based on 135% of rated current in accordance with the National Electrical Code®, Article 460.

kVAR	240V				480V				600V			
	Current (Amperes)	Wire Size ①	Fuse (Amperes)	Switch (Amperes)	Current (Amperes)	Wire Size ①	Fuse (Amperes)	Switch (Amperes)	Current (Amperes)	Wire Size ①	Fuse (Amperes)	Switch (Amperes)
0.5	1.2	14	3	30	—	—	—	—	—	—	—	—
1	2.4	14	6	30	1.2	14	3	30	1.0	14	3	30
1.5	3.6	14	6	30	1.8	14	3	30	1.4	14	3	30
2	4.8	14	10	30	2.4	14	6	30	1.9	14	6	30
2.5	6.0	14	10	30	3.0	14	6	30	2.4	14	6	30
3	7.2	14	15	30	3.6	14	6	30	2.9	14	6	30
4	9.6	14	20	30	4.8	14	10	30	3.8	14	10	30
5	12	14	20	30	6.0	14	10	30	4.8	14	10	30
6	14	14	25	30	7.2	14	15	30	5.8	14	10	30
7.5	18	12	30	30	9.0	14	15	30	7.2	14	15	30
8	19	10	35	60	9.6	14	20	30	7.7	14	15	30
10	24	10	40	60	12	14	20	30	9.6	14	20	30
12.5	30	8	50	60	15	14	25	30	12	14	20	30
15	36	8	60	60	18	12	30	30	14	14	25	30
17.5	42	6	80	100	21	10	40	60	17	12	30	30
20	48	6	80	100	24	10	40	60	19	10	35	60
22.5	54	4	100	100	27	10	50	60	22	10	40	60
25	60	4	100	100	30	8	50	60	24	10	40	60
30	72	3	125	200	36	8	60	60	29	8	50	60
35	84	2	150	200	42	6	80	100	34	8	60	60
40	96	1	175	200	48	6	80	100	38	6	80	100
45	108	1/0	200	200	54	4	100	100	43	6	90	100
50	120	2/0	200	200	60	4	100	100	48	6	100	100
60	144	3/0	250	400	72	2	125	200	58	4	100	100
75	180	250M	300	400	90	1/0	150	200	72	3	125	200
80	192	300M	350	400	96	1/0	175	200	77	3	150	200
90	216	350M	400	400	108	1/0	200	200	86	1	150	200
100	241	400M	400	400	120	2/0	200	200	96	1	175	200
120	289	(2)3/0	500	600	144	3/0	200	200	115	2/0	200	200
125	300	(2)3/0	500	600	150	3/0	250	400	120	2/0	200	200
150	361	(2)250M	600	600	180	250M	300	400	144	3/0	250	400
180	432	(2)350M	750	800	216	350M	400	400	173	250M	300	400
200	481	(2)400M	800	800	241	400M	400	400	192	300M	350	400
240	—	—	—	—	289	(2)3/0	500	600	231	400M	400	400
250	—	—	—	—	300	(2)4/0	500	600	241	400M	400	400
300	—	—	—	—	361	(2)250M	600	600	289	(2)3/0	500	600
360	—	—	—	—	432	(2)350M	750	800	346	(2)250M	600	600
400	—	—	—	—	480	(2)500M	800	800	384	(2)300M	650	800

① 90°C Copper Type THHN, XHHW, or equivalent, applied at 75°C ampacity. Rate current based on operation at rated voltage, frequency, and kVAR. Consult National Electrical Code for other wire types. Above size based on 30°C ambient operation. (Refer to NEC Table 310.16.)

Note: Fuses furnished within capacitor assembly may be rated at higher value than shown in this table. The table is correct for field installations and reflects the manufacturer's suggested rating for overcurrent protection and disconnect means in compliance with the National Electrical Code.

Where should I install capacitors in my plant distribution system?

At the load

Because capacitors act as kVAR generators, the most efficient place to install them is directly at the motor, where kVAR is consumed. Three options exist for installing capacitors at the motor. Use **Figure 10** through **Figure 16** and the information below to determine which option is best for each motor.

Location A—motor side of overload relay

- New motor installations in which overloads can be sized in accordance with reduced current draw
- Existing motors when no overload change is required

Location B—line side of starter

- Existing motors when overload rating surpasses code

Location C—line side of starter

- Motors that are jogged, plugged, reversed
- Multi-speed motors
- Starters with open transition and starters that disconnect/reconnect capacitor during cycle
- Motors that start frequently
- Motor loads with high inertia, where disconnecting the motor with the capacitor can turn the motor into a self-excited generator

At the service feeder

When correcting entire plant loads, capacitor banks can be installed at the service entrance, if load conditions and transformer size permit. If the amount of correction is too large, some capacitors can be installed at individual motors or branch circuits.

When capacitors are connected to the bus, feeder, motor control center, or switchboard, a disconnect and overcurrent protection must be provided.

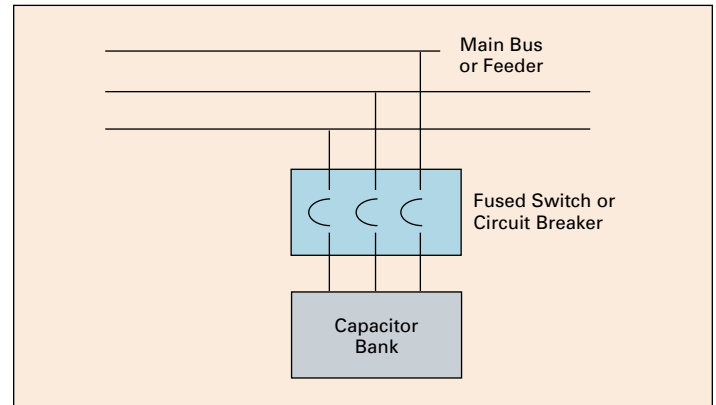

Figure 10. Installing Capacitors Online

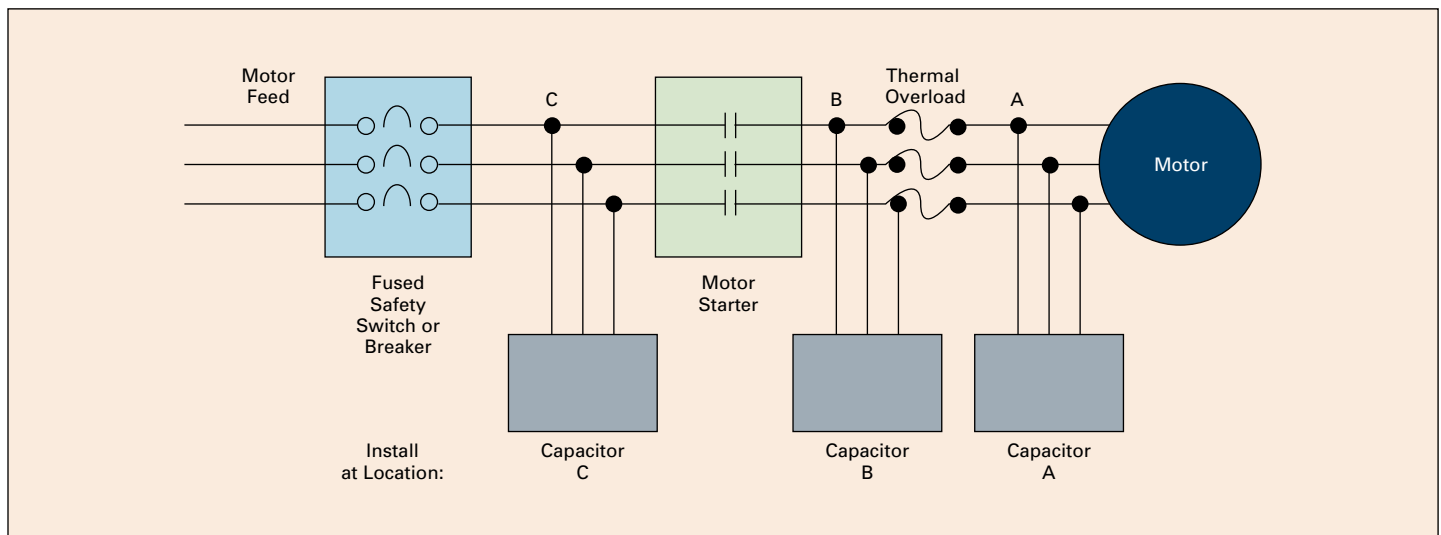

Figure 11. Locating Capacitors on Motor Circuits

Locating capacitors on reduced voltage and multi-speed motors

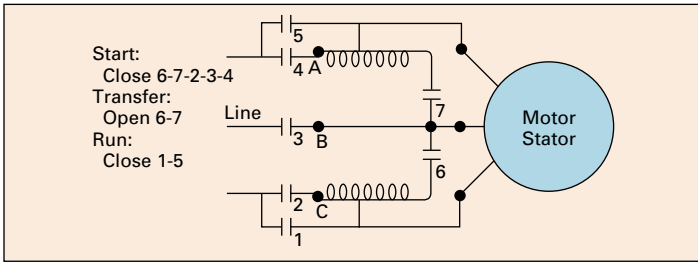

Figure 12. Autotransformer—Closed Transition

Note: Connect capacitor on motor side of starting contacts (2, 3, 4) at points A–B–C.

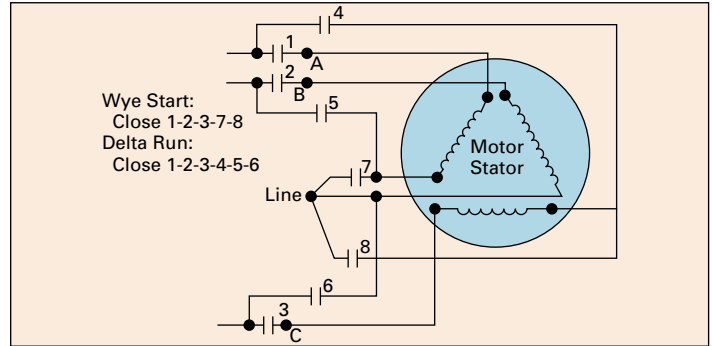

Figure 15. Wye-Delta Starting

Note: Connect capacitor on motor side of starting contacts (1, 2, 3) at points A–B–C.

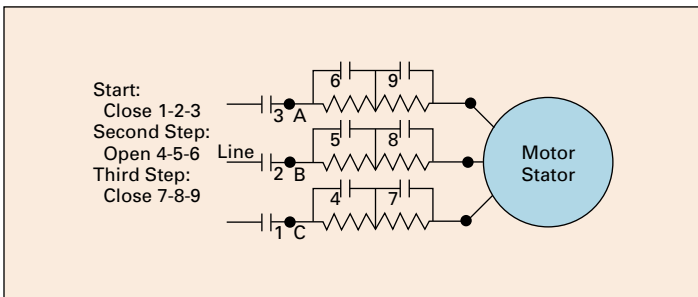

Figure 13. Series Resistance Starting

Note: Connect capacitor on motor side of starting contactor (1, 2, 3) at points A–B–C.

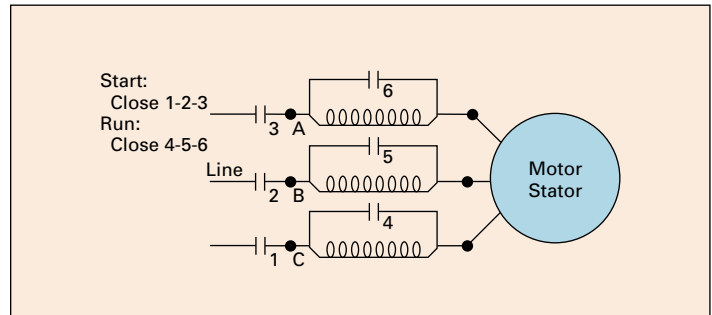

Figure 16. Reactor Starting

Note: Connect capacitor on motor side of starting contactor (1, 2, 3) at points A–B–C.

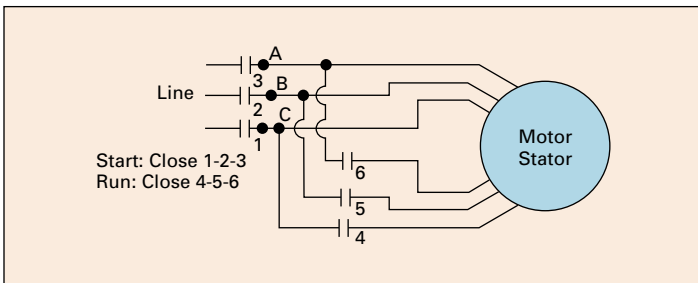

Figure 14. Part-Winding Starting

Note: Connect capacitor on motor side of starting contacts (1, 2, 3) at points A–B–C.

Can capacitors be used in nonlinear, nonsinusoidal environments?

Until recently, almost all loads were linear, with the current waveform closely matching sinusoidal voltage waveform and changing in proportion to the load. Lately, nonlinear loads—which draw current at frequencies other than 60 Hz—have increased dramatically.

Examples of linear and nonlinear devices are as follows:

Linear devices

- Motors
- Incandescent lighting
- Heating loads

Nonlinear devices

- DC drives
- Variable frequency drives
- Programmable controllers
- Induction furnaces
- Arc-type lighting
- Personal computers
- Uninterruptible power supplies (UPSs)

The increase in nonlinear loads has led to harmonic distortion in electrical distribution systems. *Although capacitors do not cause harmonics, they can aggravate existing conditions.*

Because harmonic voltages and currents are affected by all of the equipment in a facility, they are sometimes difficult to predict and model.

Capacitor banks and transformers can cause resonance

Capacitors and transformers can create dangerous resonance conditions when capacitor banks are installed at the service entrance. Under these conditions, harmonics produced by nonlinear devices can be amplified manyfold.

Problematic amplification of harmonics becomes more likely as more kVAR is added to a system that contains a significant amount of nonlinear load.

You can estimate the resonant harmonic by using this formula:

$$h = \sqrt{\frac{kVA_{sys}}{KVAR}}$$

kVA_{sys} = short-circuit capacity of the system

KVAR = amount of capacitor kVAR on the line

h = the harmonic number referred to a 60 Hz base

If h is near the values of the major harmonics generated by a nonlinear device—for example, 3, 5, 7, 11—then the resonance circuit will greatly increase harmonic distortion.

For example, if the plant has a 1500 kVA transformer with 5½% impedance, and the short-circuit rating of the utility is 48,000 kVA, then kVA_{sys} would equal 17,391 kVA.

If 350 kVAR of capacitors were used to improve power factor, h would be:

$$h = \sqrt{\frac{17,391}{350}} = \sqrt{49.7} = 7.0$$

Because h falls right on the 7th harmonic, these capacitors could create a harmful resonance condition if nonlinear devices were present in the factory. In this case, the capacitors should be applied only as harmonic filtering assemblies. For further information, see Harmonic Filter on **Page 22** of this document.

See **Page 19** (Part 2) for an additional discussion on harmonics.

What about maintenance?

Capacitors have no moving parts to wear out and require very little maintenance. Check fuses on a regular basis. If high voltages, harmonics, switching surges, or vibration exists, fuses should be checked more frequently.

Capacitors from Eaton operate warm to the touch. If the case is cold, check for blown fuses, open switches, or other power losses. Also check for bulging cases and puffed-up covers, which signal operation of the capacitor interrupter.

Code requirements for capacitors

Nameplate kVAR: Tolerance +15, –0%.

Discharge resistors: Capacitors rated at 600V and less must reduce the charge to less than 50V within 1 minute of de-energization. Capacitors rated above 600V must reduce the charge within 5 minutes.

Continuous operation: Up to 135% rated (nameplate) kVAR, including the effects of 110% rated voltage (121% kVAR), 15% capacitance tolerance, and harmonic voltages over the fundamental frequency (60 Hz).

Dielectric strength test: Twice the rated AC voltage (or a DC voltage 4.3 times the AC rating for non-metalized systems).

Overcurrent protection: Fusing between 1.65 and 2.5 times rated current to protect case from rupture. Does not preclude NEC requirement for overcurrent protection in all three ungrounded conductors.

Note: When capacitor is connected to the load side of the motor overcurrent protection, fused disconnects or breaker protection is not required. However, Eaton highly recommends fusing for all indoor applications whenever employees may be working nearby.

Useful capacitor formulas

Nomenclature:

C = Capacitance in μF
V = Voltage
A = Current
k = 1000

Additional data

Simplified voltage rise:

$$\% \text{ V.R.} = \frac{\text{kVAR (cap.)} \times \% \text{ transformer reactance}}{\text{kVA (transformer)}}$$

Losses reduction:

$$\% \text{ L.R.} = 100 - 100 \left(\frac{\text{original PF}}{\text{improved PF}} \right)^2$$

Operation at other than rated voltage and frequency:

Note: Use of voltages and frequencies above the rated values can be dangerous. Consult the factory for any unusual operating conditions.

Reduced voltage:

$$\text{Actual kVAR (output)} = \text{Rated kVAR} \left(\frac{\text{actual voltage}}{\text{rated voltage}} \right)^2$$

Reduced frequency:

$$\text{Actual kVAR} = \text{Rated kVAR} \left(\frac{\text{actual frequency}}{\text{rated frequency}} \right)$$

Examples:

Voltage reduction:

$$\text{kVAR (208)} = \text{kVAR (240)} \left(\frac{208}{240} \right)^2 = 0.75$$

(10 kVAR @ 240V = 7.5 kVAR @ 208V)

$$\text{kVAR (120)} = \text{kVAR (240)} \left(\frac{120}{240} \right)^2 = 0.25$$

(10 kVAR @ 240V = 2.5 kVAR @ 120V)

Frequency reduction:

$$\text{kVAR (50 Hz)} = \text{kVAR (60 Hz)} \left(\frac{50}{60} \right) = 0.83$$

(60 kVAR @ 480V, 60 Hz = 50 kVAR, 480V, 50 Hz)

Miscellaneous

$$\text{Power factor} = \text{Cos } \theta = \frac{\text{kW}}{\text{kVA}}$$

$$\text{Tan } \theta = \frac{\text{kVAR}}{\text{kW}} \quad (\text{See Table 6.})$$

$$\text{Single-phase kW} = \frac{V \times A \times \text{PF}}{10^3}$$

$$\text{Three-phase kW} = \frac{\sqrt{3} \times V \times A \times \text{PF}}{10^3}$$

$$\text{Single-phase kVA} = \frac{V \times A}{10^3}$$

$$\text{Three-phase kVA} = \frac{\sqrt{3} \times V \times A}{10^3}$$

$$\text{Single-phase line current (A)} = \frac{\text{kVA} \times 10^3}{V}$$

$$\text{Three-phase line current (A)} = \frac{\text{kVA} \times 10^3}{\sqrt{3} \times V}$$

$$\text{Capacitor current (A)} = (2\pi f) CV \times 10^{-6}$$

$$\text{Single-phase capacitor current} = \frac{\text{kVAR} \times 10^3}{V}$$

$$\text{Three-phase capacitor current} = \frac{\text{kVAR} \times 10^3}{\sqrt{3} \times V}$$

$$\text{kVA} = \frac{\text{kW (kW motor input)}}{\text{PF}}$$

$$\text{(kW motor input)} = \frac{\text{hp} \times 0.746}{\text{efficiency}}$$

Approximate motor kVA = motor hp (at full load)

Table 8. Standard Data

Voltage	μF / kVAR Total	Amperes / kVAR	
		Single-Phase	Three-Phase
208	61.2	4.81	2.78
240	46.0	4.17	2.41
480	11.5	2.08	1.20
600	7.37	1.67	0.96
2400	0.46	—	0.24
4160	0.153	—	0.139

Note: Above is at nominal voltage @ 60 Hz = nominal kVAR μF and current.

Part two: harmonics

Introduction

There has been much discussion and interest in recent years on the subject of power quality. Whereas in the past, power received from the electric utility and used by an industrial plant was generally a pure sinusoidal waveform—for example, clean power—more frequently today, industrial plants are finding that they have to deal with the problem of “dirty” power. Dirty power is a slang expression used to describe a variety of voltage and current contaminations on the pure sinusoidal waveform. Dirty power can come in the form of short-term transients or steady-state, continuous distortions. In addition, the sources of dirty power can be external to a plant (as might be the case if a neighboring plant is contaminating the utility’s distribution system), or the source can reside within the plant itself.

Harmonic distortion is a specific type of dirty power that is usually associated with an industrial plant’s increased use of adjustable speed drives, power supplies, and other devices that use solid-state switching. However, harmonic distortion can be generated by any of a variety of nonlinear electrical devices existing within a manufacturing plant or within nearby plants. Because harmonic distortion can cause serious operating problems in certain plant environments, it is important that the plant engineer or facilities personnel understand the fundamentals of harmonic distortion, know how to recognize the symptoms of this problem, and know what can be done to solve the problems once they are identified.

What are harmonics?

A harmonic is a component of a periodic wave having a frequency that is an integral multiple of the fundamental power line frequency of 60 Hz. For example, 300 Hz (5 x 60 Hz) is a 5th order harmonic of the fundamental frequency (**Figure 17**). **Figure 18** shows the resultant wave when the fundamental and 5th harmonic are combined. The result is harmonic distortion of the power waveform.

Harmonics typically seen on a power system can be subdivided into two distinct categories by the nature of the problems they create and the remedies they usually require.

- Those harmonic currents that are the dominant harmonic orders created by three-phase nonlinear loads—5th, 7th, 11th, 13th, and higher order odd harmonics that are not multiples of three
- Those harmonics created primarily by single-phase nonlinear loads—3rd order harmonics and higher multiples of three. These are sometimes referred to as triplen or zero-sequence harmonics and are usually accompanied by some 5th, 7th, and other higher order harmonics

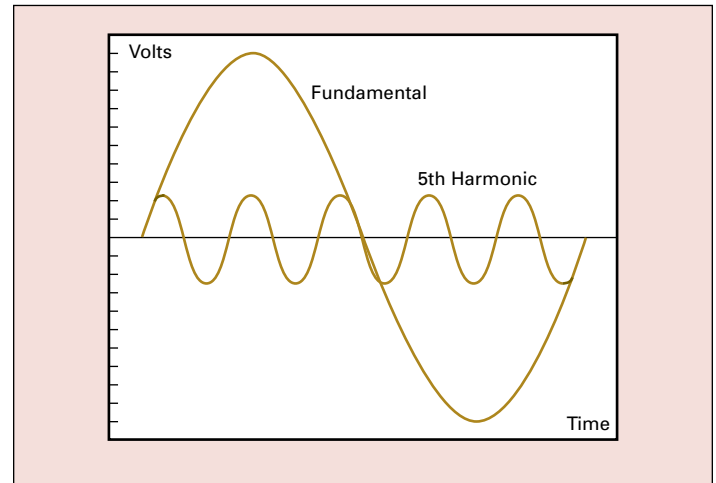

Figure 17. Fundamental and 5th Harmonic

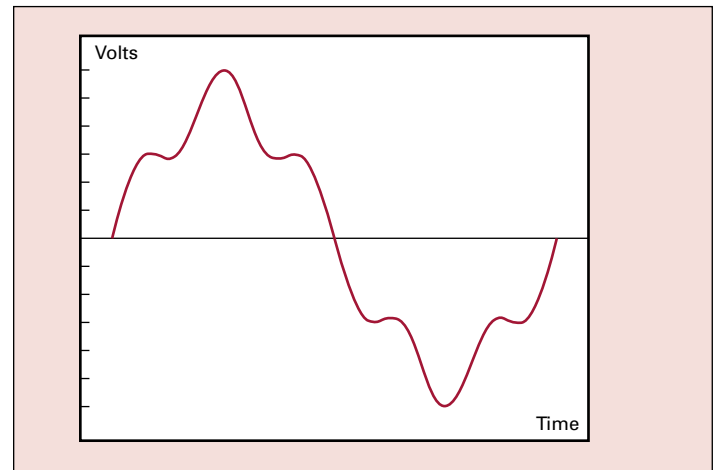

Figure 18. Fundamental and 5th Harmonic Combined

Harmonics are a steady-state phenomenon and should not be confused with short-term phenomena that last less than a few cycles. Transients, electrical disturbances, overvoltage surges, and undervoltage sags in the supplied voltage are not harmonics. Some of these short-term disturbances in voltage or current can be mitigated by transient voltage surge suppressors, line reactors, or isolation transformers. However, these devices usually have little, if any, effect on harmonic currents or voltages.

The level of voltage or current harmonic distortion existing at any one point on a power system can be expressed in terms of the total harmonic distortion (THD) of the current or voltage waveform. The THD (for a voltage waveform) is given by the following formula:

$$V_{\text{thd}} = \frac{\sqrt{V_2^2 + V_3^2 + \dots + V_n^2}}{V_1}$$

where: V_1 = fundamental voltage value
 V_n (n = 2, 3, 4, etc. ...) = harmonic voltage values

What are the consequences of high harmonic distortion levels?

Just as high blood pressure can create stress and serious problems in the human body, high levels of harmonic distortion can create stress and resultant problems for the utility's distribution system and the plant's distribution system, as well as all of the equipment that is serviced by that distribution system. The result may be the plant engineer's worst fear—the shutting down of important plant equipment ranging from a single machine to an entire line or process.

Equipment shutdown can be caused by a number of events. As an example, the higher voltage peaks that are created by harmonic distortion put extra stress on motor and wire insulation, which ultimately can result in insulation breakdown and failure. In addition, harmonics increase rms current, resulting in increased operating temperatures for many pieces of equipment, greatly reducing equipment life.

Table 9 summarizes some of the negative consequences that harmonics can have on typical equipment found in the plant environment. While these effects are categorized by problems created by current and voltage harmonics, current and voltage harmonic distortion usually exist together (current harmonic distortion causes voltage harmonic distortion).

Harmonic distortion disrupts plants. Of greatest importance is the loss of productivity, throughput, and, possibly, sales. These occur because of process shutdowns due to the unexpected tripping of motors, drives, power supplies, or just the spurious tripping of breakers. Plant engineers realize how costly downtime can be and pride themselves in maintaining low levels of plant downtime. In addition, maintenance and repair budgets can be severely stretched. For example, every 10°C rise in the operating temperatures of motors or capacitors can cut equipment life by 50%.

Table 9. Negative Consequences of Harmonics on Plant Equipment

Equipment	Consequences
Current Harmonic Distortion Problems	
Capacitors	Blown fuses, reduced capacitor life
Motors	Reduced motor life, inability to fully load motor
Fuses/breakers	False/spurious operation, damaged components
Transformers	Increased copper losses, reduced capacity
Voltage Harmonic Distortion Problems	
Transformers	Increased noise, possible insulation failure
Motors	Mechanical fatigue
Electronic loads	Misoperation

IEEE 519

IEEE® Standard 519-1992, *IEEE Recommended Practices and Requirements for Harmonic Control in Electrical Power Systems*, represents the most recent effort to establish a standard level of acceptable harmonic distortion levels on a power system.

Table 10 and **Table 11** summarize the voltage and current harmonic distortion limits.

Note: The current distortion limits are dependent upon the size of the customer's load relative to the available short-circuit capacity of the utility (stiffness). In this way, customers whose loads potentially have more effect on the utility system and neighboring customers are held to the tighter limits.

Table 10. End User Limits—Current Distortion Limits for General Distribution Systems End-User Limits (120–69,000V) Maximum Harmonic Current Distortion in % of I_L Individual Harmonic Order (Odd Harmonics)

I_{sc}/I_L	<11	11≤h<17	17≤h<23	23≤h<35	35≤h	TDD
<20 ①	4.0	2.0	1.5	0.6	0.3	5.0
20<50	7.0	3.5	2.5	1.0	0.5	8.0
50<100	10.0	4.5	4.0	1.5	0.7	12.0
100<1000	12.0	5.5	5.0	2.0	1.0	15.0
>1000	15.0	7.0	6.0	2.5	1.4	20.0

① All power generation equipment is limited to these values of current distortion, regardless of actual I_{sc}/I_L .

Notes: Even harmonics are limited to 25% of the odd harmonic limits above. Current distortions that result in a direct current offset—for example, half wave converters—are not allowed.

Where I_{sc} = maximum short-circuit current at PCC
and I_L = maximum demand load current (fundamental frequency component) at PCC.

Table 11. Utility Limits—Voltage Distortion Limits

Bus Voltage at PCC	Individual Voltage Distortion (%)	Total Voltage Distortion THD (%)
69 kV and below	3.0	5.0
69.001 kV–161 kV	1.5	2.5
161 kV and above	1.0	1.5

Note: High voltage systems can have up to 2.0% THD where the cause is an HVDC terminal that will attenuate by the time it is tapped for a user.

Two very important points must be made in reference to the above limitations:

- The customer is responsible for maintaining a current distortion to within acceptable levels, while the utility is responsible for limiting voltage distortion
- The limits are only applicable at the point of common coupling (PCC) between the utility and the customer. The PCC, while not explicitly defined, is usually regarded as the point at which the utility equipment ownership meets the customer's, or the metering point. Therefore, the above limits cannot be meaningfully applied to, say, distribution panels or individual equipment within a plant—the entire plant must be considered when complying with these limits

Electric utilities are currently considering financial penalties and/or service interruption for customers injecting excessive harmonics into the utility system. Therefore, while a customer may not be currently penalized for low power factor, a harmonic distortion-based penalty structure, in the manner of IEEE 519, may be forthcoming.

How are harmonics generated?

Harmonics are generated by nonlinear loads. A nonlinear load is a circuit element that draws current in a nonsinusoidal manner. Until recently, most factory loads were primarily linear, with current waveform closely matching the sinusoidal voltage waveform and changing in proportion to the load. More recently, however, factory loads with major nonlinear components have increased dramatically.

Table 12 gives typical examples of linear and nonlinear devices.

Table 12. Examples of Linear and Nonlinear Devices

Primarily Linear Devices	Devices with Major Nonlinear Components
Some motors	DC drives
Incandescent lighting	Variable frequency drives
Heating loads	Programmable controllers
	Induction furnaces
	Solid-state uninterruptible power supplies (UPSs)
	Arc furnaces
	Arc welders

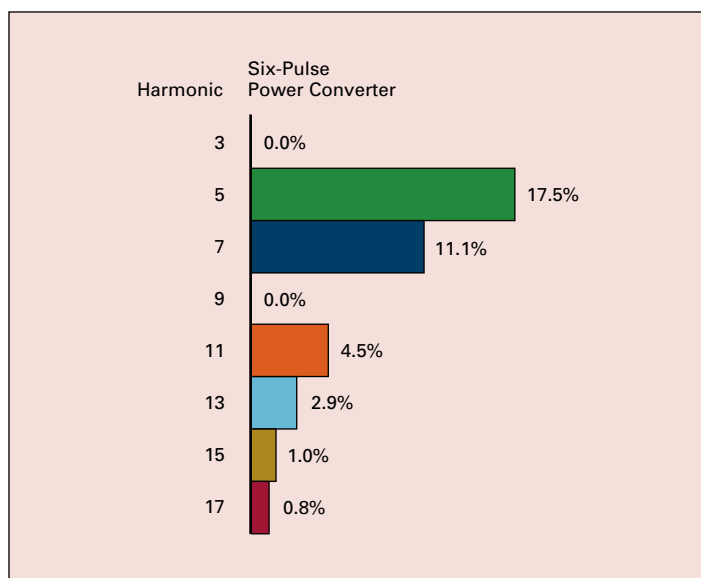

Figure 19. Harmonic Magnitude as Percentage of the Fundamental Current

Note: Harmonic currents typically injected by six-pulse VFDs.

Nonlinear devices that cause the most problems can generally be grouped into two categories—electronic power converters and arcing devices.

Electronic power converters

Electronic power converters—for example, adjustable speed drives and power supplies—are by far the largest contributors to harmonic distortion in today's plant environment. An electronic power converter changes electrical energy from one form to another, typically by rectifying the AC voltage into DC and utilizing the DC voltage directly or synthesizing a new AC voltage. This change is accomplished by using solid-state devices—silicon control rectifiers (SCRs), diodes, transistors—to periodically switch in the conducting circuits of the converter. **Figure 19** shows a typical harmonic current spectrum for a six-pulse electronic power converter. Below are some common names that are typically associated with electronic power converters.

Common names given to electronic power converters

- Adjustable speed drives
- Variable frequency drives
- SCR drives
- AC motor drives (AC/DC/AC)
- DC motor drives (AC/DC)
- Three-phase full wave rectifiers
- Three-phase full wave converters
- Six-pulse converters

As most plant engineers appreciate, there is an increased use of electronic drives due to their ability to more efficiently or precisely drive a motor or process.

Arcing devices

Arc furnaces and welders are the two types of arcing devices that cause the most harmonic distortion, although arc lighting (fluorescent, mercury vapor) will also cause small degrees of harmonic distortion.

Other equipment

Motors, generators, transformers, and arc lighting also have small nonlinear components, although the contribution of these devices to total harmonic distortion in a plant tends to be relatively small.

What do power factor correction capacitors have to do with harmonics?

A discussion of power system harmonics is incomplete without discussing the effects of power factor correction capacitors. In an industrial plant containing power factor correction capacitors, harmonic currents and voltages can be magnified considerably due to the interaction of the capacitors with the service transformer. This is referred to as *harmonic resonance* or *parallel resonance*. For a typical plant containing power factor correction capacitors, the resonant frequency (frequency at which amplification occurs) normally falls in the vicinity of the 5th to the 13th harmonic. Because nonlinear loads typically inject currents at the 5th, 7th, 11th, and 13th harmonics, a resonant or near-resonant condition will often result if drives and capacitors are installed on the same system, producing the symptoms and problems outlined in the previous section.

Note: Capacitors themselves do not cause harmonics, but only aggravate potential harmonic problems. Often, harmonic-related problems do not “show up” until capacitors are applied for power factor correction.

It is a common misconception that the problem of applying capacitors in harmonic environments is limited to problems caused for the capacitor itself—that the capacitor’s lower impedance at higher frequencies causes a current overload into the capacitor and, therefore, must be removed. However, the capacitor/harmonics problem must be viewed from a power system standpoint. The capacitor-induced increase of harmonic voltages and currents on a plant’s system may be causing problems while the capacitor itself remains within its acceptable current rating.

How do I diagnose a potential harmonics-related problem?

If a plant engineer suspects that he might have a harmonics problem, the following steps can easily be performed as an initial investigation into potential problems:

- Look for symptoms of harmonics as listed in **Table 9**. If one or more of these symptoms occurs with regularity, then the following steps should be taken
- If the plant contains power factor correction capacitors, the current into the capacitors should be measured using a “true rms” current meter. If this value is higher than the capacitor’s rated current at the system voltage (by >5% or so), the presence of harmonic voltage distortion is likely
- Conduct a paper audit of the plant’s harmonic-producing loads and system configuration. This analysis starts with the gathering of kVA or horsepower data on all the major nonlinear devices in the plant, all capacitors, and rating information on service entrance transformer(s). Eaton has specific analysis forms with instructions to guide the plant engineer in collecting this information, and engineers or sales representatives can provide assistance as needed. This data is analyzed by Eaton engineers to determine whether the conditions are present to create unfavorable levels of harmonics
- If the electrical distribution system is complex—for example, multiple service entrances, distributed capacitors—or if the paper audit is incomplete or considered to be too burdensome, the most definitive way to determine whether harmonics are causing a problem is through an on-site plant audit. This audit involves an inspection of the electrical system layout and connected loads, as well as harmonic measurements taken at strategic locations. This data can then be assembled and analyzed to obtain a clear and concise understanding of the power system. Eaton provides an engineering service to conduct these on-site plant audits

How can harmonics problems be eliminated?

When power factor correction is required in the presence of nonlinear loads, or the amount of harmonic distortion must be reduced to solve power quality problems or avoid penalties, the most reliable, lowest cost solution is often realized with the use of harmonic filters.

What is a passive harmonic filter?

A shunt harmonic filter (see **Figure 20**) is, essentially, a power factor correction capacitor combined with a series iron core reactor. A filter provides power factor correction at the fundamental frequency and becomes an inductance (like a motor) at frequencies higher than its turning point. Eaton harmonic filters are almost always tuned below the 5th harmonic. Therefore, the filter provides an inductive impedance path to those currents at harmonic frequencies created by nearly all three-phase nonlinear loads (5th, 7th, 11th, 13th, and so on). Since the filter is not capacitive at these frequencies, the plant electrical system can no longer resonate at these frequencies and cannot magnify the harmonic voltages and currents. A shunt harmonic filter therefore accomplishes three things:

- Provides power factor correction
- Prevents harmonic overvoltages due to parallel resonance
- Reduces voltage harmonic distortion and transformer harmonic loading at frequencies above its turning point

In some circumstances, a harmonic resonance condition may accrue gradually over time as capacitors and nonlinear loads are installed in a plant. In those instances, replacement of such capacitors with harmonic filters is in order to correct the problem.

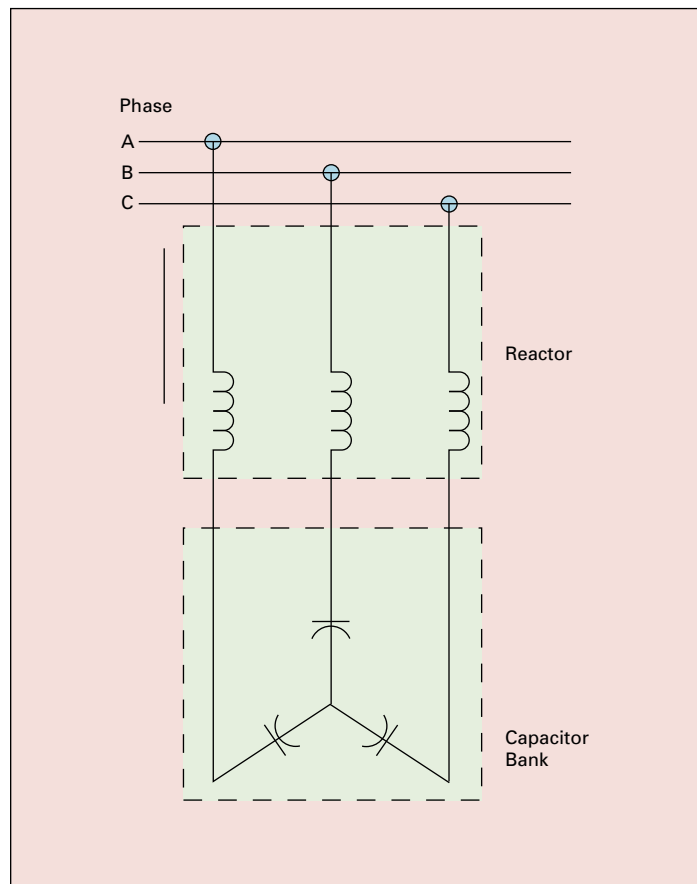

Figure 20. Shunt Harmonic Filter

Do I need to perform a system analysis to correctly apply harmonic filters?

The proper application of harmonic filters can be greatly simplified by recognizing that there are only a few pieces of pertinent information and analysis steps that need to be taken for most systems in order to correctly deal with the problem.

Eaton's approach to power system harmonic diagnosis and solutions has evolved, via years of accumulated knowledge and experience, to an approach that eliminates needless analytical complexity in the majority of circumstances. Rather, it relies on the relatively few pieces of information that are required to make the correct applications decision. If this information indicates that some type of metering and measurement is required, then only those select measurements that yield useful information will be performed, keeping the complexity and cost to a minimum without sacrificing solution correctness.

Our abilities in the area of harmonic analysis, however, extend to our state-of-the-art computerized analysis tools should the customer require the thoroughness afforded by such tools.

One of the most basic and useful pieces of information that *must* be known before attempting to correct power factor in the presence of nonlinear loads is the ratio of the total nonlinear kVA to the service transformer kVA rating. This ratio alone can often be used to determine whether harmonic filters are necessary to correct power factor or whether plain capacitors can be added without experiencing problems as follows:

- If the plant's total three-phase nonlinear load (in kVA, 1 hp = 1 kVA) is more than 25% of the main transformer capacity, harmonic filters will almost always be required for power factor correction
- If the plant's total three-phase nonlinear load is less than 15% of the main transformer capacity, capacitors can usually be applied without problems
- If the plant's total nonlinear load is between 15 and 25%, other factors should be considered

Starting with this most basic information, your Eaton sales representative will work with you to determine what additional information or measurement, if any, is required in order to recommend the correct solution to your problem.

What is Eaton's experience in harmonic filtering?

Eaton has been in the power capacitor business for 70 years, manufacturing power factor correction capacitors used in low voltage and medium voltage applications. In the 1980s, we began working with a number of customers to help resolve problems related to harmonic distortion. During that time, we developed a number of designs to incorporate harmonic filtering in both fixed and automatic capacitor banks. The success of these installations has made Eaton the leader in the field of harmonic filters.

With a fully integrated manufacturing process, we maintain the strictest quality control systems in the industry. All power capacitors are 100% tested at various stages in their manufacture and prior to shipment to ensure a long service life. In addition, Eaton provides on-site supervision and startup assistance to ensure that all capacitor and harmonic filtering assemblies are properly applied in the plant environment.

Please call **1-800-809-2772** for assistance in understanding and solving any problems that you have involving capacitors or harmonics in your facility.

Eaton is dedicated to ensuring that reliable, efficient and safe power is available when it's needed most. With unparalleled knowledge of electrical power management across industries, experts at Eaton deliver customized, integrated solutions to solve our customers' most critical challenges.

Our focus is on delivering the right solution for the application. But, decision makers demand more than just innovative products. They turn to Eaton for an unwavering commitment to personal support that makes customer success a top priority. For more information, **visit www.eaton.com/electrical**.

Eaton
1000 Eaton Boulevard
Cleveland, OH 44122
United States
Eaton.com

© 2014 Eaton
All Rights Reserved
Printed in USA
Publication No. SA02607001E / Z15663
August 2014