

Reducing Fault Stress with Zone-Selective Interlocking

Data Bulletin

0600DB0001

R11/11 04/2012



by **Schneider** Electric

Table of Contents

| | |
|---|----|
| Zone-Selective Interlocking | 3 |
| What is Zone-Selective Interlocking (ZSI) | 3 |
| Why Use Zone-Selective Interlocking? | 3 |
| Fault Stress | 3 |
| Maximizing Continuity of Service with Coordination | 3 |
| How Zone-Selective Interlocking Work | 4 |
| ZSI System Operation | 5 |
| Devices Capable of ZSI | 7 |
| Circuit Breakers with Micrologic™ Trip Units | 8 |
| Add-On Ground-fault Module | 8 |
| ZSI System Considerations | 8 |
| How Many Levels of the System Should Be Interlocked? | 8 |
| Should All Circuit Breakers at a Common Level Be Interlocked? | 9 |
| Circuit Breaker Self-restraint | 9 |
| What Can Interfere with Proper ZSI System Operation? | 10 |
| Testing for Proper ZSI Operation | 10 |
| Installation of Zone-selective Interlocking Using | |
| Square D™ Equipment | 11 |
| Verify Coordination | 11 |
| Control Wiring | 11 |
| Field Testing | 11 |
| Conclusion | 12 |
| ZSI Using PowerPact H-, J- and L-Frame Circuit Breakers | 13 |
| Zone-Selective Interlocking | 13 |
| Connecting Downstream PowerPact H, J, L Circuit Breakers to Upstream PowerPact L Circuit Breaker | 14 |
| One-to-One Connection | 14 |
| One-to-Several Connection | 15 |
| One-to-Many Connection | 16 |
| Connecting Downstream PowerPact H, J, L Circuit Breakers to Upstream Masterpact NW/NT, PowerPact P/R, or Compact NS Circuit Breaker | 17 |
| Multiple Downstream Circuit Breakers | 19 |
| Using GC200 Ground Fault Relay | 19 |
| Connecting Powerpact H, J, L to Series B Using a RIM | 20 |
| Connecting Powerpact H, J, L to Masterpact NT/NW or PowerPact P/R Using a RIM | 21 |
| Verifying ZSI Connections | 22 |
| Connecting PowerPact H-, J-, or L-Frame Circuit Breakers to Multiple Devices of Different Families | 23 |
| Field Testing | 23 |
| ZSI Using LE, PG, PJ, PL, RG, RJ, RL and Masterpact™ Circuit Breakers | 24 |
| LE Circuit Breakers with Micrologic Full-Function Trip Units | 25 |
| PG, PJ, PL, RG, RJ, RL and Masterpact™ Circuit Breakers with Micrologic 5.0A/P/H or 6.0A/P/H Trip Units | 26 |
| Ground-Fault Module (GFM) for H- and J-Frame Circuit Breakers | 27 |
| Restraint Interface Module (RIM) Usage | 28 |
| Restraint Signal Voltage Boost | 28 |
| Voltage Drop | 28 |
| Wiring ZSI Connections | 29 |
| Earth Grounding of Shielded Cables | 29 |
| Power Supply Connections/Requirements | 29 |

Zone-Selective Interlocking

What is Zone-Selective Interlocking (ZSI)

Zone-selective interlocking (ZSI), also called zone restraint, is a system designed to reduce the stress on electrical distribution equipment during short-circuit or ground-fault conditions.

ZSI works with a previously coordinated distribution system to limit fault stress on the system by reducing the time it takes to clear the fault while maintaining system coordination between overcurrent and ground-fault protective devices.

Why Use Zone-Selective Interlocking?

In today's electrical distribution systems, two major and conflicting concerns are the potential for damage from fault stress and the costs associated with power outages. The best way to limit fault stress is to clear the fault in the shortest amount of time. Unfortunately, clearing the fault in the shortest amount of time could sacrifice coordination and lead to broader power outages.

Coordination assures that continuity of service is maximized during any overcurrent or ground fault. The upstream circuit breaker nearest the fault will open to clear the fault while all other circuit breakers in the system remain closed, which provides continuity of service to the unaffected parts of the system. However, coordination does not reduce the stress on the system caused by the energy generated during a fault; in fact, it may add to it.

ZSI on a coordinated system is the best solution to reduce costs associated with both fault stress and power outages.

Fault Stress

Fault conditions can cause thermal and mechanical stresses on the electrical system. Thermal stress is a result of the energy dissipated in the system during a fault and can be expressed as let-through energy (I^2t) (the fault current squared times the length of time the fault persists). Mechanical stress is the result of peak current that causes high magnetic forces that can bend bus bars, whip conductors and break insulators.

Indications of thermal stress include the following:

- Damage to conductor insulation
- Burned or melted components
- Scorched labels, peeled paint or other evidence of high temperature

One way to minimize the fault stress is to reduce the amount of time that the fault exists on the system. This can be achieved by using overcurrent and ground-fault devices that interrupt as quickly as possible under fault conditions.

The problem with choosing devices solely on their interrupting speed is that coordination may be sacrificed. More than one device may open to clear the fault, or upstream circuit breakers may trip causing unnecessary power outages to unaffected parts of the electrical system.

Overcurrent protective devices must be coordinated to minimize how much of the system loses power during an electrical fault.

Coordination is the process of localizing an overcurrent or ground-fault condition to restrict the outage to only affected equipment. Only the upstream circuit breaker nearest the fault trips, leaving the remainder of the electrical system intact to supply power to unaffected areas.

Figure 1: Damaged Conductor

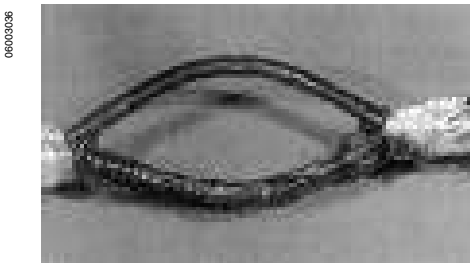

Maximizing Continuity of Service with Coordination

Figure 2: Adjustment Dials

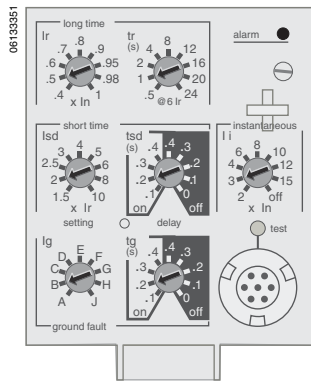

Micrologic Trip Unit Adjustment Dials

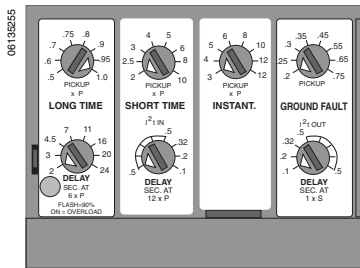

Series B Trip Unit Adjustment Dials

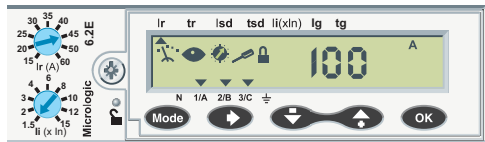

PowerPact H/J/L Trip Unit Adjustment Dials and Touchpad

In order to maximize coordination, downstream branch devices should operate very fast, with no intentional delay, and main devices should delay operation so that the downstream devices can clear the fault.

Electronic trip devices, such as circuit breakers with Micrologic™ trip units and Ground-Fault Modules (GFM), have adjustable pickup and delay settings to maximize coordination with other overcurrent and ground-fault protective devices in the system.

In a coordinated system, longer delays and higher pickups are selected on upstream devices to allow downstream devices to trip first.

Unfortunately, this results in longer tripping times because the circuit breakers wait for the selected delay time before tripping. This can expose the system to large amounts of fault stress

Figure 3: Power Distribution Systems

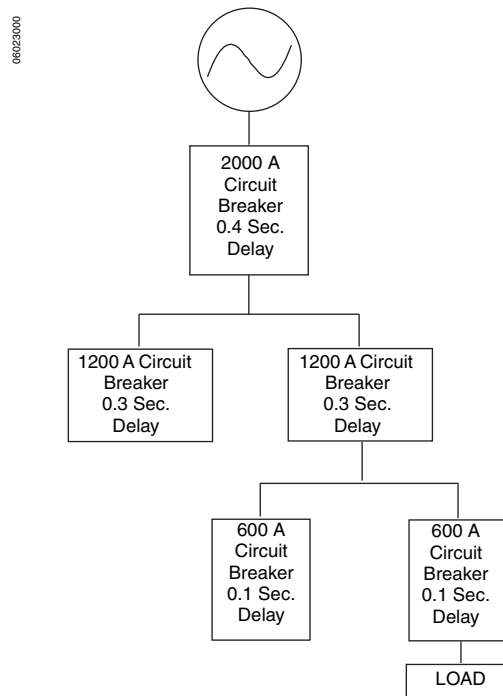

How Zone-Selective Interlocking Work

ZSI allows electronic trip devices to communicate with each other so that a short circuit or ground fault will be isolated and cleared by the nearest upstream circuit breaker with no intentional time delay. Devices in all other areas of the system (including upstream) remain closed to maintain service to unaffected loads.

Without ZSI, a coordinated system results in the circuit breaker closest to the fault clearing the fault, but usually with an intentional delay. With ZSI, the device closest to the fault will ignore its preset short-time and/or ground-fault delays and clear the fault with no intentional delay.

Zone-selective interlocking eliminates intentional delay, without sacrificing coordination, resulting in faster tripping times. This limits fault stress by reducing the amount of let-through energy the system is subjected to during an overcurrent. The reduction in let-through energy can be as much as 86%. (See Figure 4 and Table 1.)

The use of ZSI will not cause circuit breakers that are not coordinated (due to improper settings) to coordinate.

Table 1: Trip Times and Let-through Comparison

| Fault | | | Without Zone-selective Interlocking | | With Zone-selective Interlocking | | |
|-------------------------|----------|----------------------------|-------------------------------------|--|----------------------------------|--|---|
| Location (See Figure 4) | Value | Cleared By Circuit Breaker | Trip Time (Sec.) | I ² t Let-through (Amperes ² Sec.) | Trip Time Unrestrained | I ² t Let-through (Amperes ² Sec.) | Reduction in I ² t Let-through |
| A | 1000 A | 175 A JG | 0.1 | 0.1 x 10 ⁶ | 0.1 Sec. | 0.1 x 10 ⁶ | Same |
| B | 2000 A | 400 A LG | 0.2 | 0.8 x 10 ⁶ | 0.07 Sec. | 0.3 x 10 ⁶ | 63% |
| C | 25,000 A | 1200 A PG | 0.5 | 312 x 10 ⁶ | 0.07 Sec. | 43 x 10 ⁶ | 86% |

A system coordination study must be done to make sure that coordination exists. A system coordination study will establish settings and verify that pickup levels and delay times cascade downward, with the largest values at the main circuit level and the smallest values at the branch circuit level. The electrical distribution system must be coordinated for any zone-selective interlocking scheme to work properly.

Figures 4 and 5 show a coordinated system.

Figure 4: Coordinated System

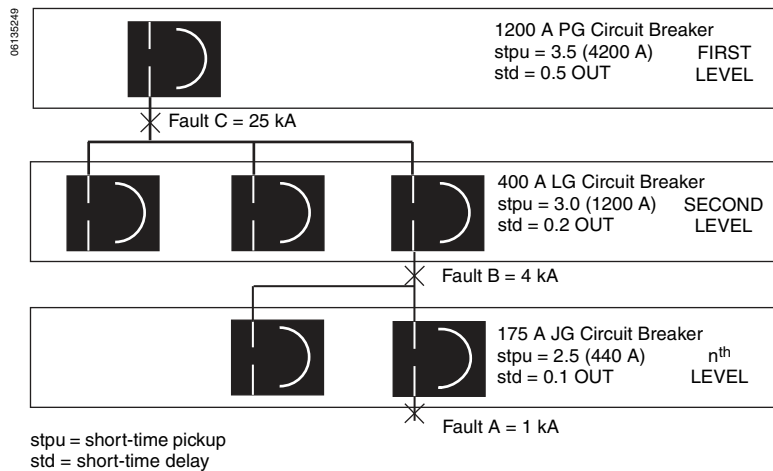
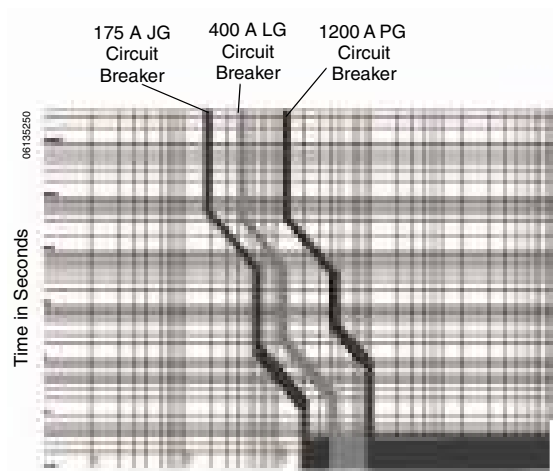

Figure 5: Coordination Study



NOTE: For more information on a system coordination study, contact your local Schneider Electric Field Office.

ZSI System Operation

For ZSI systems, a “zone” is that area downstream of an overcurrent device, yet upstream of the next overcurrent device. If a short circuit or a ground fault occurs in an overcurrent device’s zone (point A is in M1’s zone in Figure 6) the preset time delay on the device (M1) is deactivated and the device will clear the fault with no intentional delay.

If a fault occurs in the zone of a downstream overcurrent device (point B in Figure 6 is in F2’s zone), where the magnitude of the fault exceeds the ground fault and/or short-time pickup on both M1 and F2, both M1 and F2 devices detect the fault. F2 sends a restraint signal upstream to M1. M1’s preset time delay is activated. F2 does not receive a restraint signal and opens to clear the fault with no intentional delay. Since M1’s preset time delay is activated, proper selectivity and coordination is maintained while still providing backup protection for F2 and other downstream devices.

Figure 6: Overcurrent Device Zone

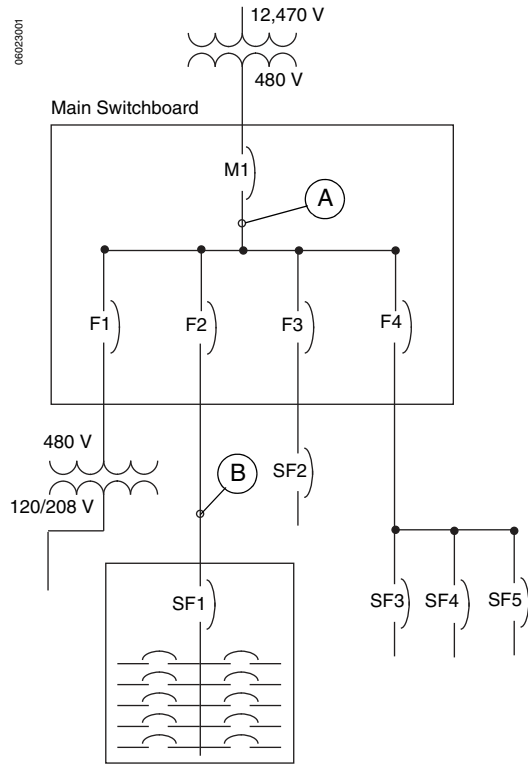

In other words, when a device equipped with ZSI senses a short circuit or ground fault, it sends a restraint signal (via the restraint wires) to the ZSI device just upstream from it. This activates the preset time delay on the upstream device.

When a device equipped with ZSI senses a short circuit or ground fault and does not receive a restraint signal, its preset time delay will not be activated and it will trip with no intentional delay.

During a fault at lower levels of the system:

- All circuit breakers (main, feeder, subfeeder, etc.) upstream of the fault will sense the fault. If the fault is above their pickup level, the feeder, subfeeder etc., will send a restraint signal upstream. The restraint signal activates the preset time delay on the upstream device.
- All circuit breakers downstream of the fault will not sense the fault and will not send a restraint signal upstream.
- Therefore, the preset time delay is activated on all circuit breakers upstream of the fault except the one closest to the fault.
- The circuit breaker closest to the fault, having received no restraint signal, will trip with no intentional delay.
- All other circuit breakers upstream of the fault, having received a restraint signal, will delay tripping for the time selected by their trip unit adjustment to maintain selectivity and coordination.

Thus, the only device that will trip in a ZSI system is the one closest to the fault, and it will do so with no intentional delay.

An example will show how this works:

Figure 7 shows a one-line diagram of a typical distribution system:

Figure 7: Typical Distribution System

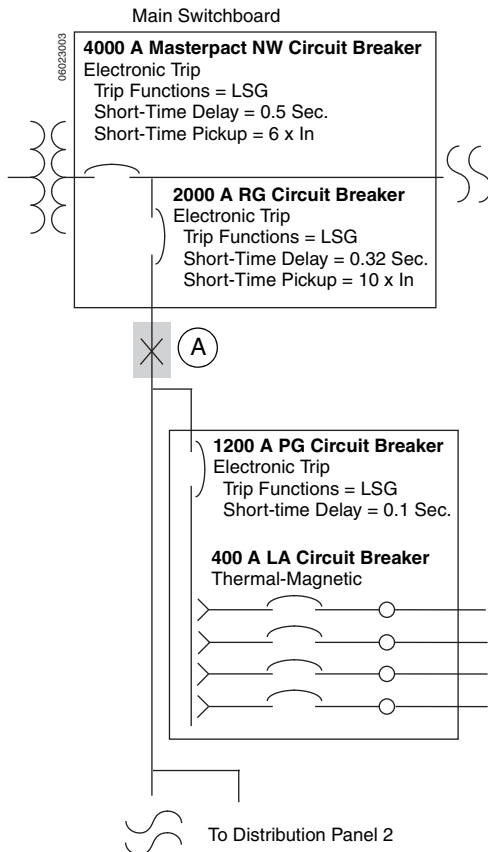

The 4000 A Masterpact NW, 2000 A PowerPact RG, and 1200 A PowerPact PG circuit breakers are coordinated on the short-time (short-circuit) function.

Assume a 25,000 ampere phase-to-phase fault occurs at point A.

- With coordination but without ZSI:
 - Both the 4000 A Masterpact NW and 2000 A PowerPact RG circuit breakers will sense the fault. The 1200 A PowerPact PG circuit breaker (downstream of the fault) will not sense the fault.
 - Both the 4000 A and 2000 A circuit breakers will begin to time out to the short-time delay selected on their trip units.
 - The 2000 A circuit breaker will wait 0.32 seconds before clearing the fault.
 - The 2000 A circuit breaker will clear the fault. The upstream (4000 A Masterpact NW) circuit breaker will remain closed because the fault was cleared before its time delay expired.
 - The outage was isolated to the nearest circuit breaker upstream of the fault. The system was coordinated but was exposed to the full stress of the fault for 0.32 seconds plus tripping time.
- With coordination and with ZSI:
 - Both the 4000 A and 2000 A circuit breakers will sense the fault. The 1200 A circuit breaker (downstream of the fault) will not sense the fault.
 - The 2000 A circuit breaker sends a restraint signal to activate the preset time delay on the 4000 A circuit breaker. The 4000 A circuit breaker begins to time out to the 0.5 second short-time delay selected on its trip unit.
 - The 2000 A circuit breaker does not receive a restraint signal, so its preset time delay is deactivated. It will trip with no intentional delay.
 - The 2000 A circuit breaker will clear the fault with no intentional delay. The upstream (4000 A Masterpact NW) circuit breaker will remain closed because the fault was cleared before its time delay expired.

The outage was isolated to the upstream circuit breaker nearest the fault. Stress on the system was minimized because the fault was cleared with no intentional delay.

Devices Capable of ZSI

Devices capable of ZSI include electronic trip devices, such as circuit breakers with Micrologic™ trip units and Ground-fault Modules (GFM).

Some devices can have ZSI on both short time and ground fault; other devices have ZSI only on short time or only on ground fault. Devices at different levels of the system communicate via control wiring between the trip units.

Circuit Breakers with Micrologic™ Trip Units

Circuit breakers with Micrologic trip units are capable of short-circuit and/or ground-fault zone-selective interlocking. Using the ZSI feature on a long-time, short-time or ground-fault (LSG) trip system means that when a short circuit or ground fault occurs, the following conditions exist:

- When the circuit breaker is not the nearest circuit breaker upstream of the fault, the trip unit preset delays allow downstream devices to clear the fault, maintaining coordination.
- When the circuit breaker is the nearest circuit breaker upstream of the fault, the electronic trip unit ignores the preset time delays and trips with no intentional delay.
- The decision to trip with or without intentional delay is made by the trip unit electronics depending on the location of the fault and the restraint signal. It does not have to be made by the system designer, contractor or maintenance electrician.

Add-On Ground-fault Module

Figure 8: Ground-Fault Modules

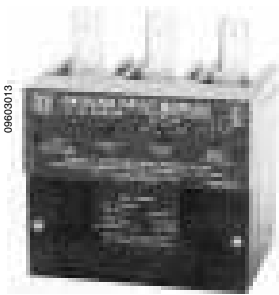

Micrologic add-on ground-fault modules provide ground-fault protection for use with Square D 100 A and 250 A frame thermal-magnetic circuit breakers. GFMs are equipped with zone-selective interlocking as a standard feature. Since these devices are capable of sensing a ground fault only (and not a short circuit), they are capable of ground-fault zone-selective interlocking only. GFMs are intended solely for branch circuit applications and have only ZSI outputs. They cannot receive restraint signals

ZSI System Considerations

When designing a ZSI system, certain questions frequently arise:

- How many levels of the system should be interlocked?
- Should all the circuit breakers at a common level be interlocked? Does it make any difference if some of the devices at a certain level are interlocked while others at the same level are not?
- What is self-restraint and where should it be used?
- Can certain devices interfere with proper ZSI system operation?
- How do I know if the ZSI system has been designed and installed properly?

How Many Levels of the System Should Be Interlocked?

ZSI is intended to protect system components from damage due to fault occurrences. The electrical distribution system can be a major investment, representing a large component of the total cost of a project. ZSI protects this investment.

Often ZSI is specified only within the main distribution board, but a more likely location for a fault occurrence is on a feeder circuit leaving the switchboard, or even lower in the system. To maximize the protection offered by using ZSI, as many levels of the system as possible need to be interlocked. This way, even devices at the lower levels of the system will trip without any intentional delay, when necessary, without sacrificing coordination. This provides true selective coordination and maximum protection against fault stress.

Should All Circuit Breakers at a Common Level Be Interlocked?

Figure 9: Feeder Circuit Breakers at a Common Level

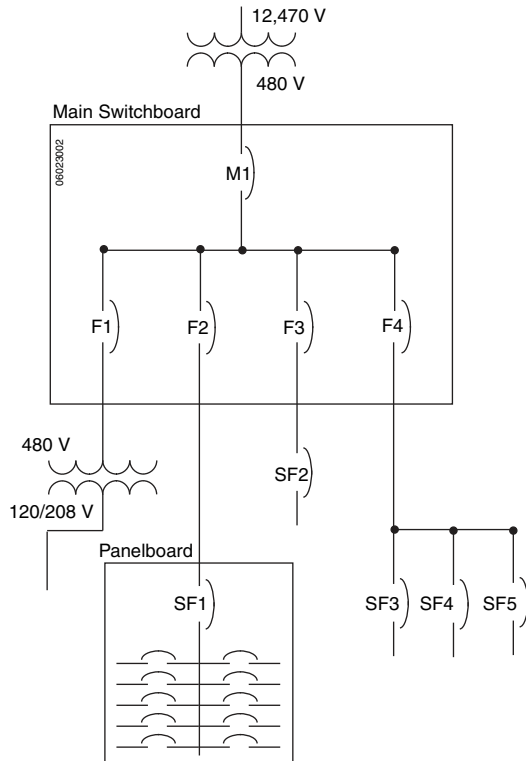

Circuit Breaker Self-restraint

ZSI is an “all or nothing” type of system. All devices at a common level should be interlocked with a common main circuit breaker. In Figure 9, feeder circuit breakers F1, F2 and F4 are all at a common level and are zone interlocked with the main circuit breaker M1, but feeder circuit breaker F3 (at the same level) is not interlocked with the main circuit breaker.

A problem occurs when a fault happens downstream of circuit breaker F3. In this case, the main circuit breaker will not receive a restraint signal, so the main circuit breaker would trip without intentional delay, taking out loads fed by circuit breakers F1, F2 and F4 (where selectivity is important), as well as circuit breaker F3. The result will be a shutdown of the total distribution system because the main circuit breaker responds as if the fault happened in its zone.

It is not necessary for all of the subfeeder devices to be interlocked in order for the ZSI system to function properly. This is because all of the devices at the subfeeder level do not have a common feeder circuit breaker—circuit breaker SF1 is fed by circuit breaker F2, but circuit breakers SF3 through SF5 are fed by circuit breaker F4. The fact that circuit breaker SF1 is interlocked but circuit breakers SF3 through SF5 are not interlocked does not prevent the ZSI system from operating correctly.

Table 2: Self-Restraint Connections

| Circuit Breaker Type/Series | Function (ST or GF) | Connect Terminal (Restraint IN) | To Terminal (Restraint OUT) |
|---------------------------------------|---------------------|---------------------------------|-----------------------------|
| LE 1B | Short-time | #5 | #6 |
| LE 1B | Ground-fault | #7 | #8 |
| PG, PJ, PL, RG, RS, RL and Masterpact | Both | Z3, Z4, Z5 | NA |

In certain areas of the system, it is necessary to self-restrain a circuit breaker to maintain the delay before tripping during a fault condition. Self-restraint is achieved by connecting jumper wires to terminal connections. This results in the circuit breaker always introducing a time delay before tripping on a short circuit or a ground fault (the time delay is always activated).

Situations where self-restraint may be appropriate include when:

- The interlocked device is feeding a non-interlocked device downstream (or a number of non-interlocked devices in a panel).
- A time delay is desired for short-circuit and/or ground-fault occurrences (usually to ride out transients and inrushes).
- Minimal tripping time would compromise coordination.

For instance, feeder circuit breaker F1 in Figure 9 must allow for transformer inrush. Therefore, feeder circuit breaker F1 is self-restrained so that the time delays are always activated and cannot be deactivated (the time delay shortened) by any ZSI communication.

Likewise, subfeeder circuit breaker SF1 in Figure 9 must delay in order to give the branch circuit breakers ample time to open the circuit. Therefore, circuit breaker SF1 is also self-restrained.

Micrologic circuit breakers with ZSI capability are shipped with self-restraint jumpers installed. Self-restraint jumpers must be in place unless zone-selective interlocking is activated. If jumpers are removed and zone-selective interlocking is not activated, the circuit breaker will ignore its programmed delay and trip with no intentional delay.

Figure 10: Typical Distribution System

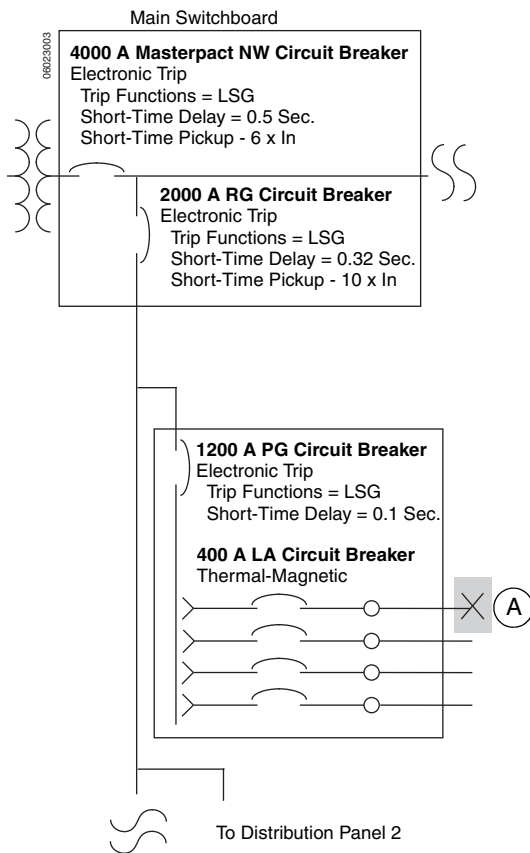

An example will show how self-restraint works (Figure 10 again shows a one-line diagram of a typical distribution system):

Assume a 25,000 ampere phase-to-phase fault occurs at point A. All upstream circuit breakers in this system will sense the fault simultaneously:

- The 1200 A PowerPact PG circuit breaker, as the lowest level interlocked device, is self-restrained and sends a restraint signal to activate its own preset time delay. The 1200 A circuit breaker begins to time out to the short-time delay selected on its trip unit.
- The 1200 A PowerPact PG circuit breaker also sends a restraint signal to activate the preset time delay on the 2000 A PowerPact RG circuit breaker. The 2000 A circuit breaker begins to time out to the short-time delay selected on its trip unit.
- The 2000 A PowerPact PG circuit breaker sends a restraint signal to activate the preset time delay on the 4000 A Masterpact NW circuit breaker. The 4000 A circuit breaker begins to time out to the short-time delay selection on its trip unit.
- The 400 A LA circuit breaker magnetic trip assembly will sense the fault and trip with no intentional delay. The 400 A LA circuit breaker clears the fault with no intentional delay. Since all upstream circuit breakers have longer delay times than the 400 A LA circuit breaker (LA circuit breaker trip time is less than 0.016 sec.), they will remain closed because the fault was cleared before the delay times had expired.
- Coordination exists because the outage was isolated to the nearest circuit breaker upstream of the fault. Stress on the system was minimized because the fault was cleared with no intentional delay. (In this case, system response would be the same with or without ZSI.)
- If the 1200 A circuit breaker were not self-restrained, it would ignore its preset short-time delay and also trip with no intentional delay (0.08 sec. maximum). Stress on the system would be minimized, but only partial coordination would exist.

There are also situations where self-restraint may be inappropriate because coordination would be compromised. Devices in the lowest level of the system (the devices closest to load) should be chosen to minimize the tripping time in order to maximize coordination. These devices should not be self-restrained—their preset time delay should be deactivated so that they trip with no intentional delay.

What Can Interfere with Proper ZSI System Operation?

Devices that interfere with coordination also interfere with proper operation of the ZSI system. Upstream devices with an instantaneous short-circuit tripping characteristic (LI or LIG trip system) interfere with coordination because they trip with no intentional delay. That means that the upstream devices may open before downstream devices have a chance to interrupt the fault. Coordination no longer exists, which results in shutting down more of the system than necessary to clear the fault.

Testing for Proper ZSI Operation

Although switchboards are factory tested, shipping, storage and installation damage may cause the system to not function as designed. Wiring connections between shipping sections and/or remote parts of the system can also cause the ZSI system to be disabled.

- Make visual and continuity checks to verify that the control wiring has been installed correctly.
- Secondary injection test units can test some electronic devices for ZSI output signals.

Installation of Zone-selective Interlocking Using Square D™ Equipment

When designing a ZSI system using Square D™ equipment, certain steps should be followed:

- Verify coordination
- Install ZSI wiring
- Test system

Verify Coordination

The most important rule to remember is to start with a coordinated system. The use of ZSI will not cause devices that are not coordinated (due to improper settings) to coordinate. The proper settings must be made with or without ZSI.

In a coordinated system, only the device closest to the fault will trip, and the rest of the system will continue to serve loads. To make sure that coordination exists, a coordination study must be performed.

A coordination study will establish settings and verify that pickup levels and delay times cascade downward—with the largest values at the main circuit breaker and the smallest values at the branch circuit level. The electrical distribution system must be coordinated in order for any zone-selective interlocking scheme to work properly.

Control Wiring

ZSI systems use control wires (called restraint wires) to provide the communication link between the electronic trip devices. The customer has the option of wiring the restraint lines or having Schneider Electric wire the function in factory-assembled equipment. Schneider Electric recommends the use of 18 AWG to 14 AWG twisted pair or shielded cable for the ZSI wiring between Square D brand devices. The shield of the cable must be grounded at ONE point only.

ZSI wiring should be run separately from power distribution conductors or bus in order to prevent interference with the ZSI restraint signal. If the length of the restraint wire exceeds 1000 feet (304.8 m), a restraint interface module (RIM) must be used to boost the restraint signal. For more information on the use of RIM modules see page 11.

Field Testing

Although switchboards are factory tested, other factors can occur once the switchboard leaves the manufacturing facility that could cause system malfunctions. To ensure that the system functions as intended, performance testing is recommended at start-up.

Visual and continuity checks should be made to verify that the control wiring has been installed correctly. Use secondary injection test units to test some electronic devices for ZSI output signals.

Conclusion

The need to act quickly to clear a fault and the need to provide coordinated protection require compromise in the selection and application of conventional overcurrent protection. However, by using electronic trip devices with zone-selective interlocking, no compromises are necessary and the fault can be cleared quickly without sacrificing coordination.

A system with zone-selective interlocking is coordinated exactly the same as any other power distribution system. By selecting longer delay times for upstream circuit breakers, downstream circuit breakers are allowed a chance to trip first. In addition, ZSI communication deactivates the preset delay on the circuit breaker closest to the fault, which then trips with no intentional delay.

Faster tripping reduces the amount of time that current flows during a fault condition. Thus, zone-selective interlocking reduces the amount of stress (I^2t energy) the system is subjected to during fault conditions, resulting in prolonged equipment life.

ZSI Using PowerPact H-, J- and L-Frame Circuit Breakers

Zone-Selective Interlocking

PowerPact H-, J-, and L-Frame circuit breakers with Micrologic trip units can be interlocked with PowerPact and Masterpact circuit breakers.

Table 3: ZSI Parameters for PowerPact H-, J-, and L-Frame Circuit Breakers

| Downstream Device | Upstream Device | Maximum upstream devices that can be direct connected to a single downstream | Maximum upstream devices that can be ZSI connected to a single downstream device if a RIM module is used | Maximum RIM modules that can be connected between the downstream device and the upstream device(s) | Maximum downstream devices that can be <u>directly</u> connected to a single upstream device without affecting <u>unrestrained</u> trip time | Maximum distance between upstream and downstream ZSI connected devices | Minimum wire size | Maximum wire | Recommended wire size |
|----------------------------------|--|--|--|--|--|--|-------------------|--------------|-----------------------|
| PowerPact H-, J-, and/or L-frame | PowerPact H-, J-, and/or L-frame circuit breakers with Micrologic trip units | 5 | 15 | 1 | 15 | 1000 ft | 24 AWG | 18 AWG | 22 AWG |
| | Masterpact NW/NT, PowerPact P/ R, Compact NS circuit breakers with Micrologic trip units | 5 | 15 | 1 | 100 | 1000 ft | 24 AWG | 18 AWG | 22 AWG |
| | GC200 | 5 | 15 | 1 | 0 | 1000 ft | 24 AWG | 14 AWG | 22 AWG |
| | LE,NE,PE,SE circuit breakers with Micrologic trip units | 0 | 15 | 1 | 1 | 1000 ft | 18 AWG | 14 AWG | 14–18 AWG |
| | RIM | 1 | 15 | 15 | 15 | 1000 ft | 24 AWG | 18 AWG | 22 AWG |

Connecting Downstream PowerPact H, J, L Circuit Breakers to Upstream PowerPact L Circuit Breaker

One-to-One Connection

A single downstream PowerPact H, J, or L circuit breaker can be directly wired to an upstream PowerPact L circuit breaker to provide ZSI restraint.

Figure 11: PowerPact H/J/L Circuit Breaker Restraining Single Upstream PowerPact L Circuit Breaker

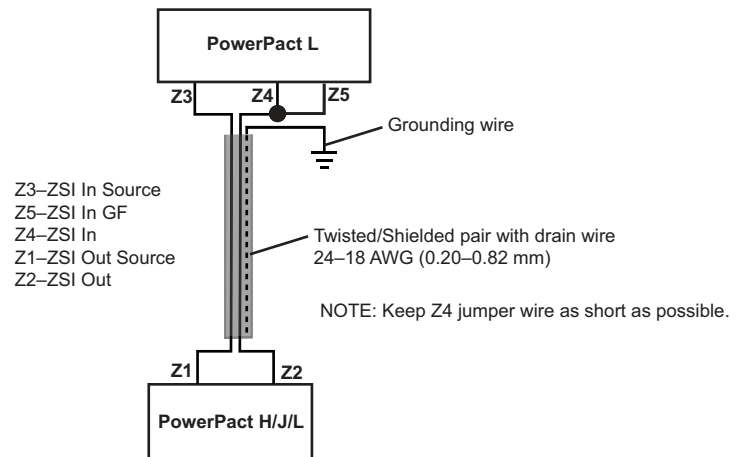

One-to-Several Connection

A single downstream PowerPact H, J, or L circuit breaker can restrain up to five upstream PowerPact L circuit breakers using terminal blocks.

Figure 12: PowerPact H/J/L Circuit Breaker Restraining Up to Five Upstream PowerPact L Circuit Breakers

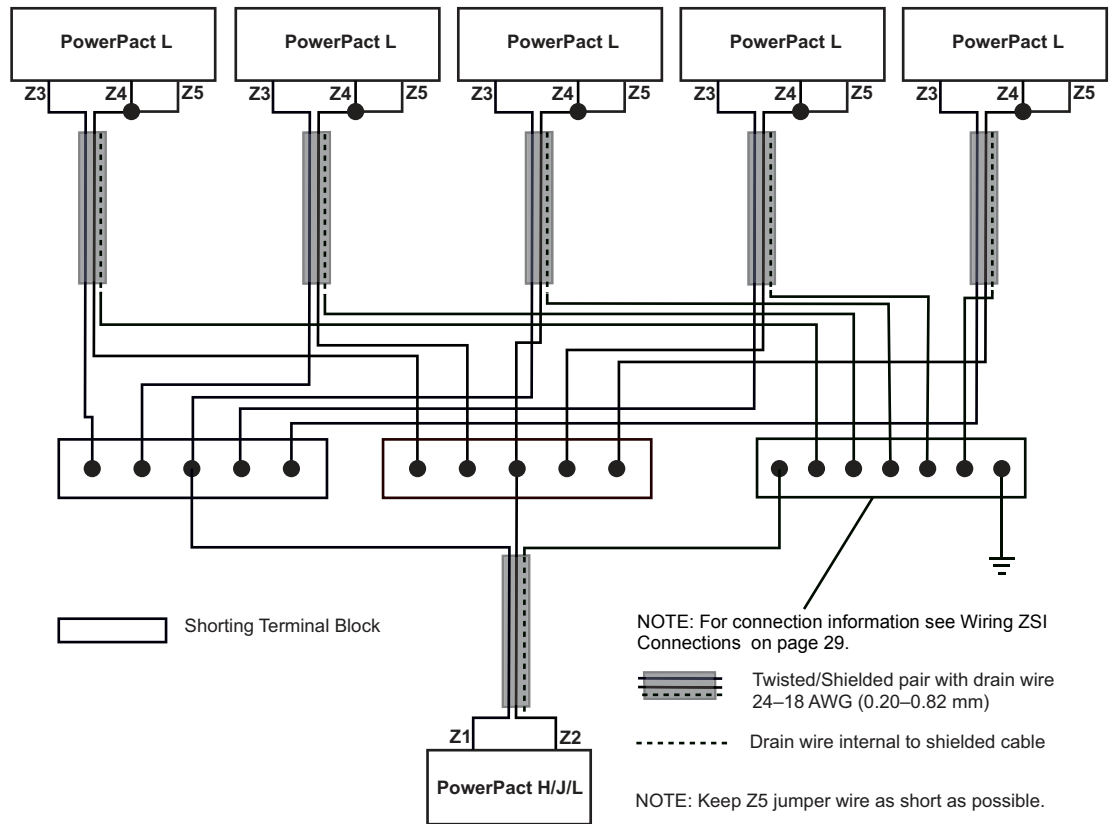

One-to-Many Connection

A Restrain Interface Module (RIM) allows up to fifteen upstream PowerPact L-frame circuit breakers to be restrained.

Figure 13: PowerPact H/J/L Circuit Breaker Restraining Up to Fifteen Upstream PowerPact L Circuit Breakers

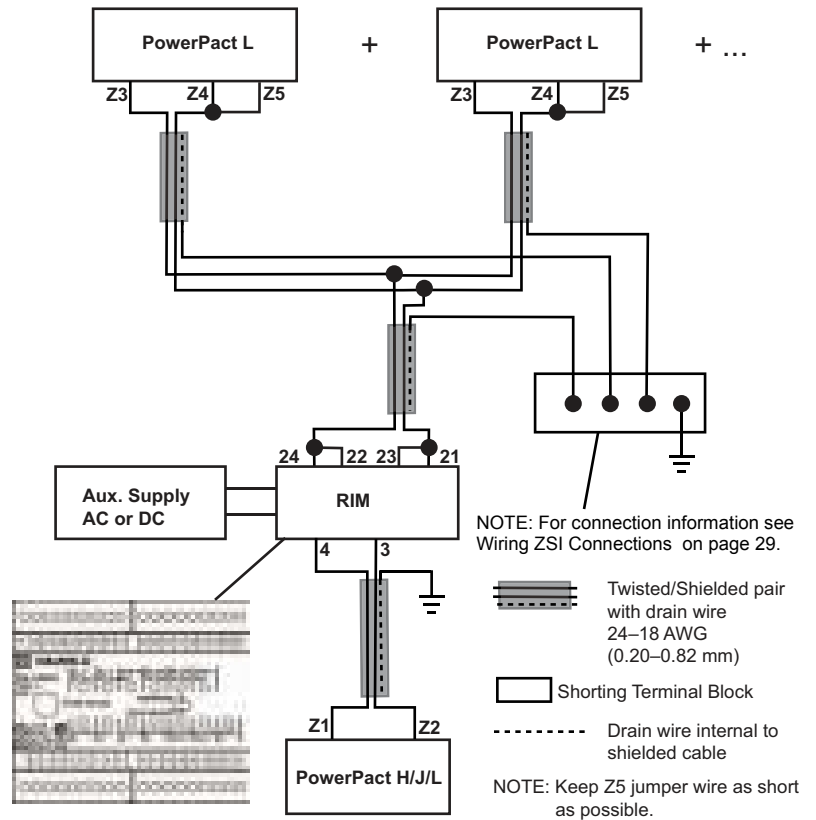

When using a RIM, proper ZSI signal integrity must be tested to ensure that the ZSI is working properly.

- Use the Local Test Utility software along with an UTA to test the ZSI wiring between the downstream Powerpact H,J, or L frame circuit breaker and the RIM. The RIM module must properly indicate the receiving of the restraint signal. See Table 4.
- Use the Push-to-Test button on the RIM module to send out a ZSI wiring test order to the multiple connected upstream Powerpact L frame circuit breakers. All upstream circuit breakers must correctly indicate the receipt of the ZSI restraint signal by displaying “zSI” on the display.

Figure 14:

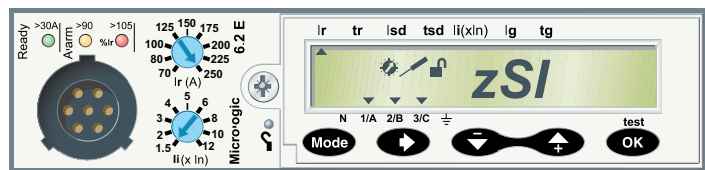

Connecting Downstream PowerPact H, J, L Circuit Breakers to Upstream Masterpact NW/NT, PowerPact P/R, or Compact NS Circuit Breaker

No more than five parallel, ZSI connected upstream Masterpact NW,NT, PowerPact P,R, and/or Compact NS circuit breakers can be used upstream from PowerPact H,J, or L frame circuit breakers without using a RIM module.

Each upstream ZSI connected circuit breaker must use a Zone Selective Interlocking (ZSI) Module (Catalog no. S434212) connected to the ZSI inputs for both ground fault and short circuit of each of the upstream circuit breakers .

Figure 15: Ground Fault and Short Circuit ZSI Connections without RIM

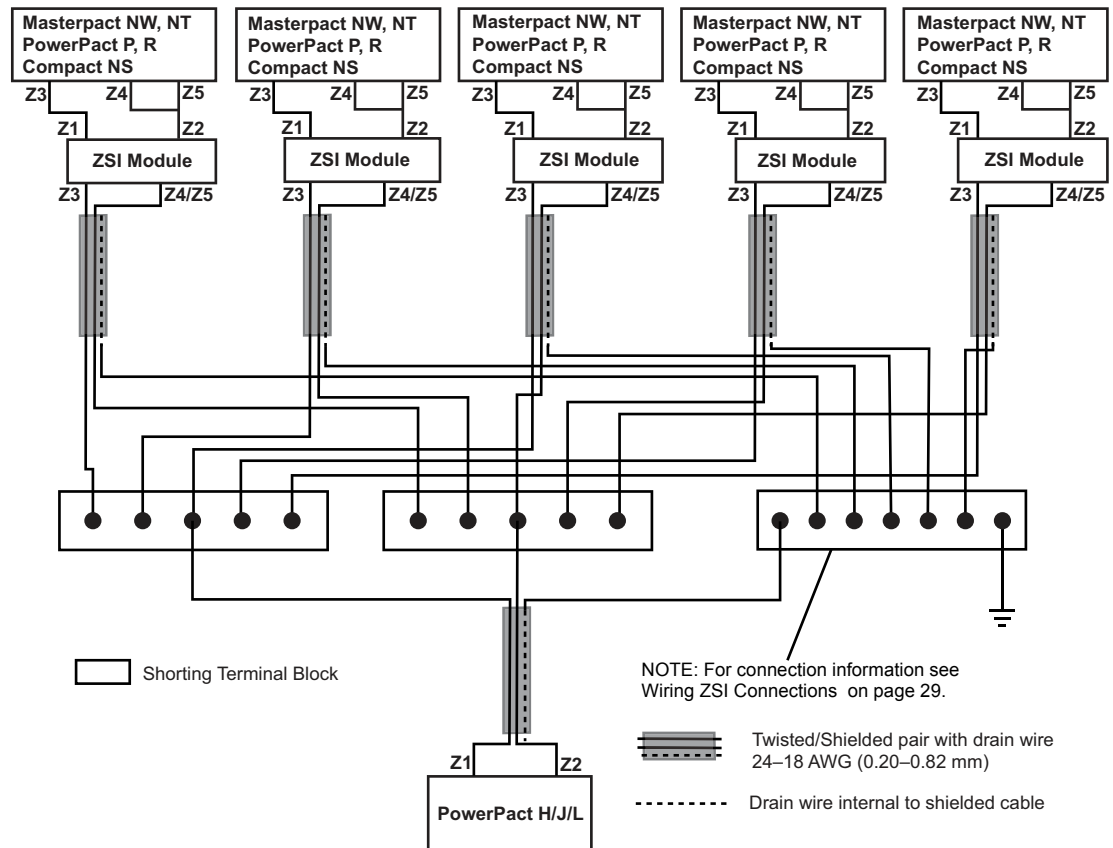

If more than 5 upstream circuit breakers are to be connected, a RIM module must be connected between the downstream Powerpact H,J, or L circuit breaker and the upstream circuit breakers. An add-on ZSI module (Catalog No. S434212) is also required.

Figure 16: Ground Fault and Short Circuit ZSI Connections with RIM

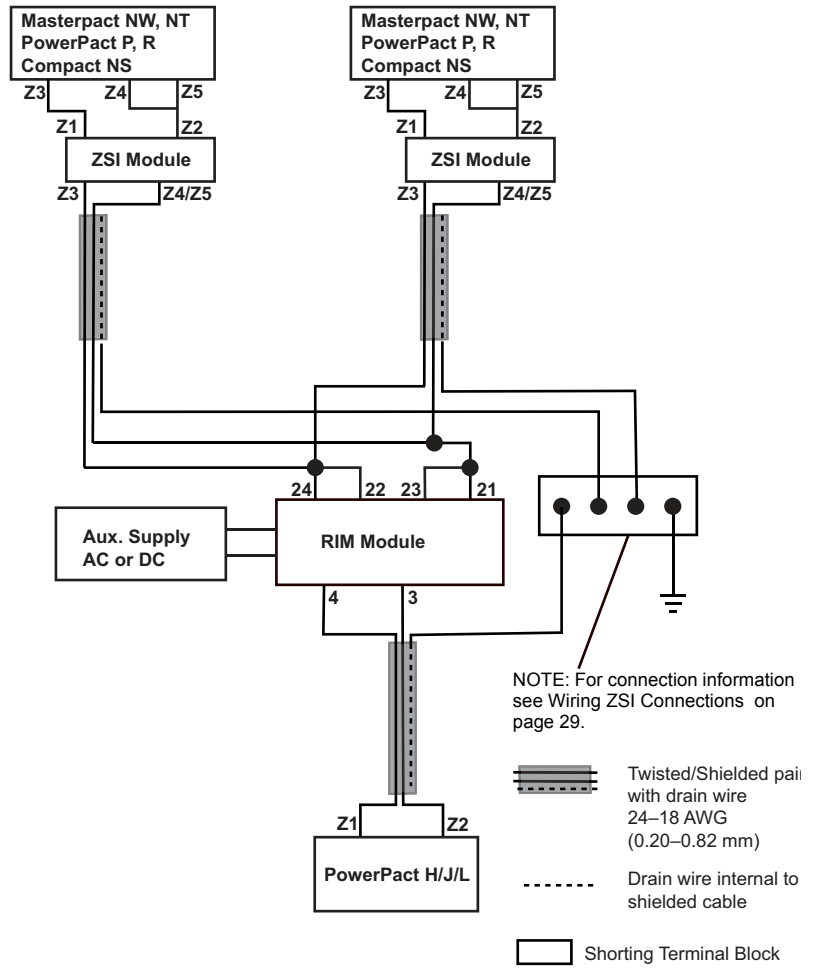

Multiple Downstream Circuit Breakers

No more than 100 parallel connected downstream PowerPact H-, J-, and/or L-frame circuit breakers can be connected to a single upstream circuit breaker.

Figure 17: Multiple Downstream Circuit Breakers

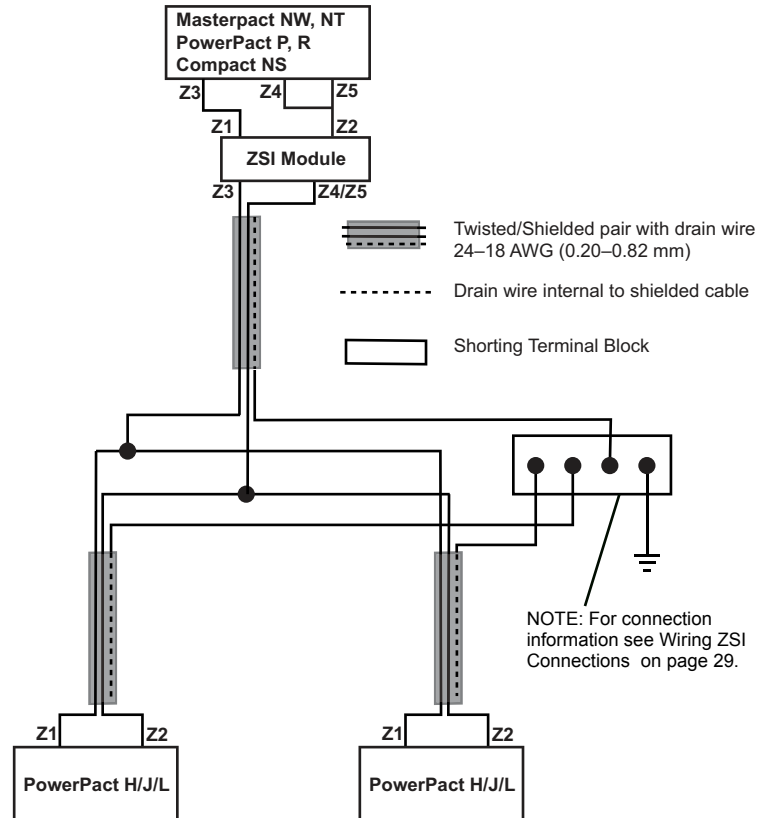

Using GC200 Ground Fault Relay

PowerPact H-, J-, and/or L-frame circuit breakers can be connected to upstream circuit breakers using the GC200 Ground Fault Relay.

- No more than 5 parallel, ZSI connected upstream circuit breakers using GC200's can be used
- Each upstream ZSI connected circuit breaker using a GC200 ground fault relay must also use a ZSI module
- If more than 5 upstream circuit breakers with GC200's are to be connected, a RIM module must be connected between the downstream Powerpact H,J, or L circuit breaker and the upstream circuit breakers using GC200's.
- The RIM module allows customer to connect up to 15 upstream circuit breakers at once.
- No more than 100 parallel connected downstream PowerPact H-, J-, and/or L-frame circuit breakers can be direct ZSI connected to a single upstream GC200 ground fault relay.

Figure 18: Ground Fault ZSI Connections using GC200 Ground Fault Relays

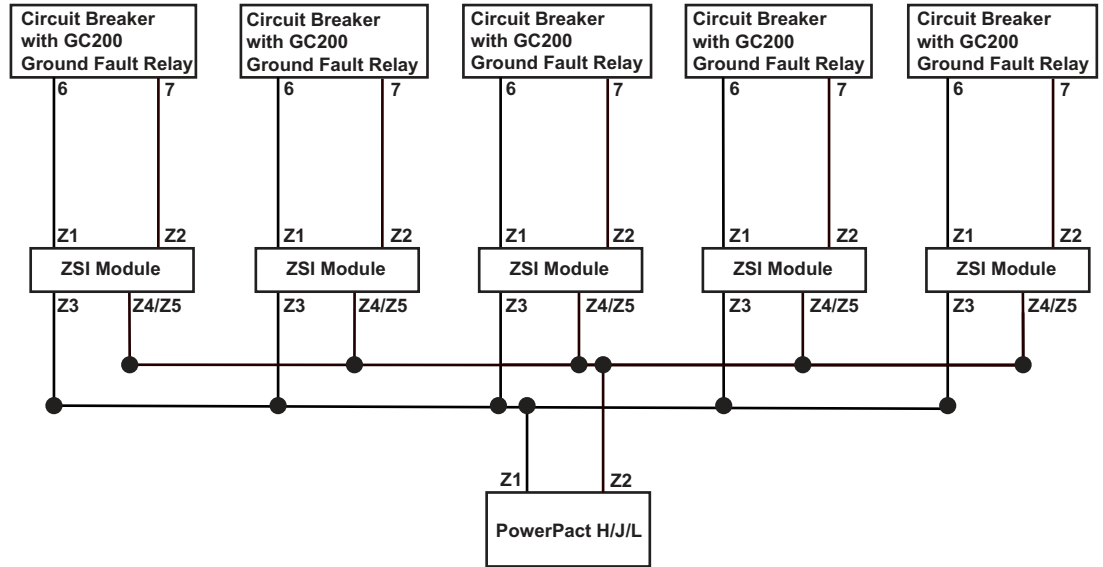

Connecting Powerpact H, J, L to Series B Using a RIM

Connecting PowerPact H-, J-, and/or L-frame circuit breakers to upstream LE, ME, NE or PE circuit breakers (which have Micrologic Series B trip units) requires the use of a Restraint Interface Module (RIM).

Figure 19:

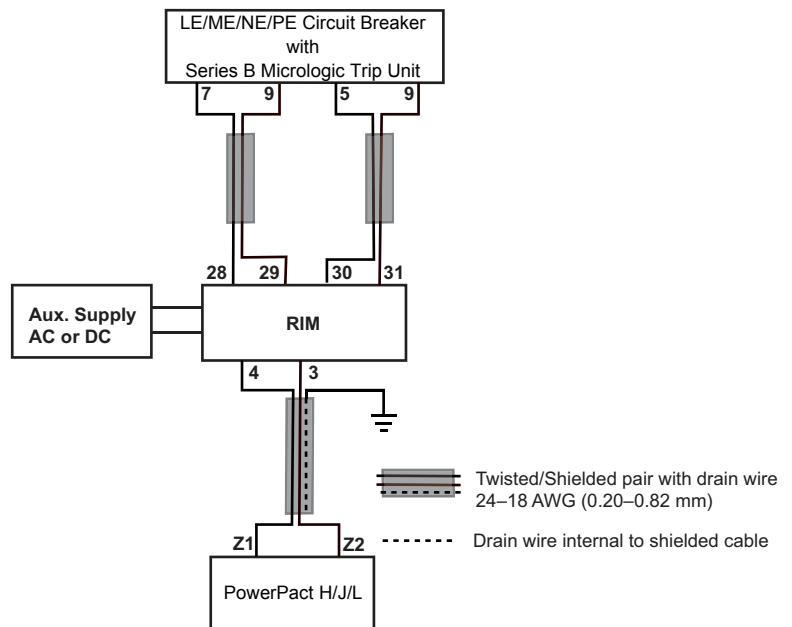

Connecting Powerpact H, J, L to Masterpact NT/NW or PowerPact P/R Using a RIM

Connecting PowerPact H/J/L circuit breakers to upstream Masterpact NT/NW or PowerPact P/R circuit breakers requires the use of a Restraint Interface Module (RIM).

Figure 20:

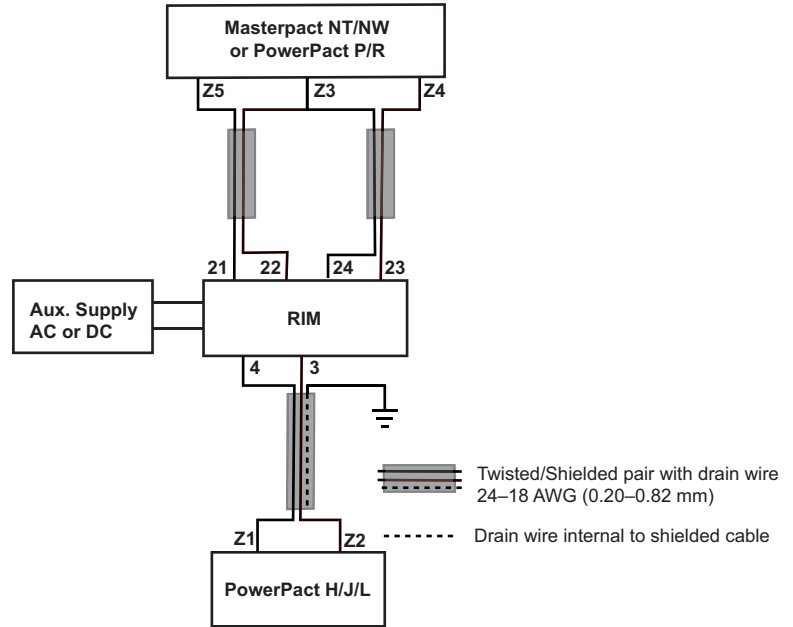

Verifying ZSI Connections

Table 4: ZSI Connections

| Downstream Device | Upstream device | Test Method | Visual indication that test is being performed | Indication on upstream device that wiring is correctly connected |
|------------------------------|---|---|--|---|
| PowerPact H-, J-, or L-Frame | Powerpact L | Test kit (UTA) connected to the test port of downstream device. Use test kit PC software utility (Local Test Utility) to test ZSI | | |
| PowerPact H-, J-, or L-Frame | Masterpact NW, NT Powerpact P,R Compact NS (630A – 6300A) | Use test kit (UTA) connected to the test port of downstream device. Using test kit PC software utility (Local Test Utility) to test ZSI | | <p>Isd will flash if short circuit protection is ZSI restrained</p> <p>Ig will flash if ground fault protection is ZSI restrained</p> |
| PowerPact H-, J-, or L-Frame | RIM module | Use test kit (UTA) connected to the test port of downstream device. Using test kit PC software utility (Local Test Utility) to test ZSI | | |
| RIM | PowerPact L | Pres the "Push to test" button on the RIM module | | |
| RIM | GC200 | Pressing the "Push to test" button on the RIM module | | <p>Yellow "Restrained" LED illuminated while test is being performed. When test is stopped, yellow indicator LED must turn off.</p> |
| RIM | Masterpact NW, NT Powerpact P,R Powerpact NS Compact NS (630A – 6300A) | Pressing the "Push to test" button on the RIM module | | <p>Isd will flash if short circuit protection is ZSI restrained</p> <p>Ig will flash if ground fault protection is ZSI restrained</p> |

Connecting PowerPact H-, J-, or L-Frame Circuit Breakers to Multiple Devices of Different Families

- PowerPact H-, J-, and/or L-frame circuit breaker trip units must be ZSI connected directly to compatible, upstream devices of the same type. For example, all upstream devices must be GC200s, the same type of Mirologic trip units, or RIM Modules
- PowerPact H-, J-, and/or L-frame circuit breaker trip units must be ZSI connected directly to compatible, downstream devices of the same type. For example, all downstream devices must be RIM modules or PowerPact H-, J-, or L-frame circuit breakers

Field Testing

Although switchboards are factory tested, other factors can occur once the switchboard leaves the manufacturing facility that could cause system malfunctions. To ensure that the system functions as intended, performance testing is recommended at start-up.

Visual and continuity checks should be made to verify that the control wiring has been installed correctly. Use secondary injection test units to test some electronic devices for ZSI output signals.

ZSI Using LE, PG, PJ, PL, RG, RJ, RL and Masterpact™ Circuit Breakers

Figure 21: Circuit Breakers with Micrologic Trip Units

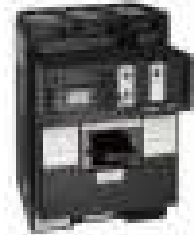

LE Circuit Breakers



PG, RG, NT and NW Circuit Breakers

LE circuit breakers with Micrologic full-function trip units are capable of short-circuit and/or ground-fault zone-selective interlocking. Full-function trip units ordered with the adjustable short-time (LS trip system) and/or the adjustable ground-fault protection (LSG or LIG trip system) are equipped with zone-selective interlocking capability as a standard feature.

PowerPact PG, PJ, PL, RG, RJ, RL and Masterpact circuit breakers with Micrologic series 5.0A/P/H or 6.0A/P/H trip units are equipped with zone-selective interlocking capability as a standard feature. The 5.0A/P/H trip units have short-time ZSI, and 6.0A/P/H trip units have both short-time and ground-fault ZSI.

Using the ZSI feature on a long-time, short-time or ground-fault (LSG) trip system means that when a short circuit or ground fault occurs, the following conditions exist:

- When the circuit breaker is not the nearest circuit breaker upstream of the fault, the trip unit preset delays allow downstream devices to clear the fault, maintaining coordination.
- When the circuit breaker is the nearest circuit breaker upstream of the fault, the electronic trip unit ignores the preset time delays and trips with no intentional delay.
- The decision to trip with or without intentional delay is made by the trip unit electronics depending on the location of the fault and the restraint signal. It does not have to be made by the system designer, contractor or maintenance electrician.

LX and LXI circuit breakers with standard function Micrologic trip units and PowerPact PG, PJ, PL, RG, RJ, RL and Masterpact circuit breakers with Micrologic trip units series 3.0 and 5.0 are not equipped with ZSI and cannot be retrofitted to have ZSI. The Micrologic trip unit for the PG, PJ, PL, RG, RJ, RL and Masterpact circuit breakers is field replaceable and can be upgraded to a 5.0A/P/H or 6.0A/P/H trip unit if ZSI is needed.

LE Circuit Breakers with Micrologic Full-Function Trip Units

ZSI wiring is run between the ZSI output terminals on downstream devices to the input terminals on upstream devices. Wiring is also run between all ZSI common terminals. Micrologic full-function trip units have short-time restraint IN and OUT, ground-fault restraint IN and OUT and a restraint common terminal. See Figures 22 and 23 for terminal identification

Figure 22: LE Circuit Breaker Terminals

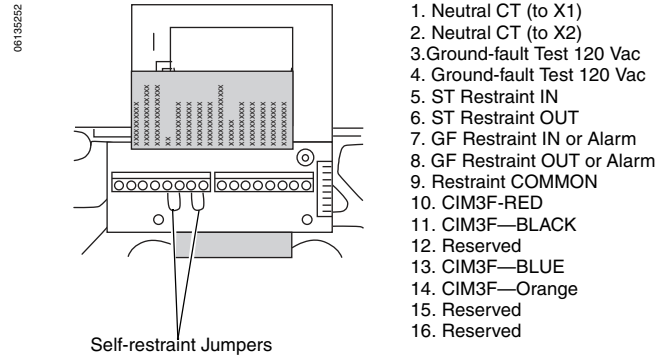

Micrologic full-function circuit breakers leave the factory with jumpers installed to restrain themselves. Generally, self-restraint jumpers should be left in place if ZSI is not used or if the application requires delay time before tripping in the event of a short circuit and/or ground fault. See Table 4 for self-restraint jumper installation.

Figure 23: LE Circuit Breaker ZSI Connections

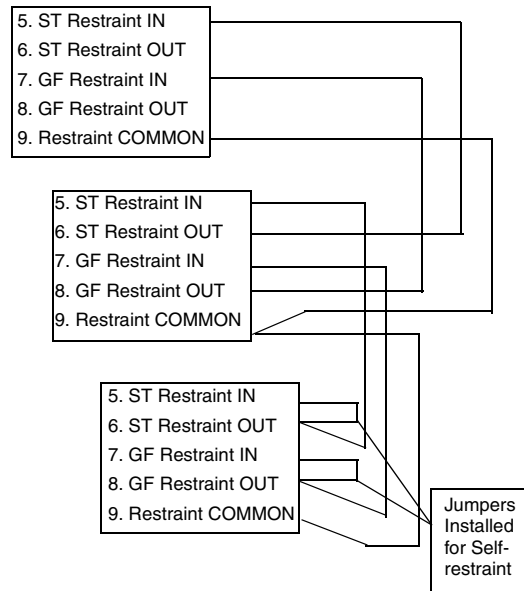

**PG, PJ, PL, RG, RJ, RL and Masterpact™
Circuit Breakers with
Micrologic 5.0A/P/H or 6.0A/P/H Trip Units**

PG, PJ, PL, RG, RJ, RL and Masterpact circuit breakers with Micrologic trip units 5.0A/P/H or 6.0A/P/H are equipped with zone-selective interlocking capability as a standard feature. 5.0A/P/H trip units have short-time ZSI and 6.0A/P/H trip units have both short-time and ground-fault ZSI.

ZSI wiring is run between the ZSI terminals on downstream devices to the ZSI terminals on upstream devices. Wiring is run from downstream ZSI OUT signal to upstream ZSI IN signal and from downstream ZSI OUT to upstream ZSI IN short-time and/or ZSI IN ground-fault terminal. See Figure 24 for details.

Figure 24: ZSI Connections

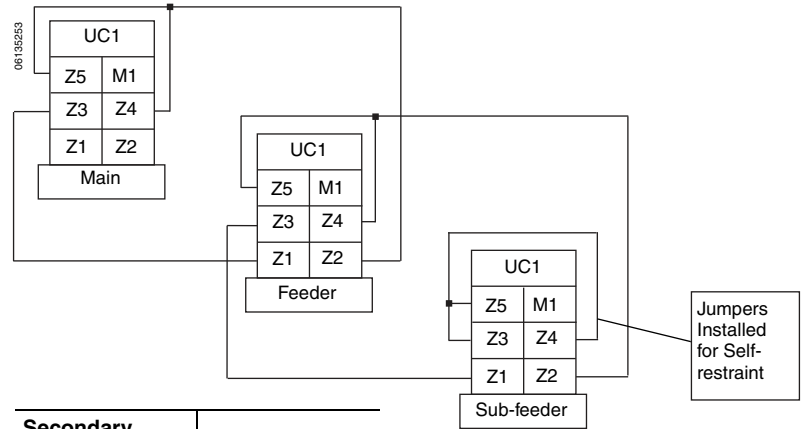

| Secondary Connector Position | Description |
|------------------------------|---------------------|
| Z1 | ZSI OUT Signal |
| Z2 | ZSI OUT |
| Z3 | ZSI IN Signal |
| Z4 | ZSI IN Short-time |
| Z5 | ZSI IN Ground-fault |

Micrologic 5.0A/P/H and 6.0 A/P/H trip units leave the factory with jumpers installed to restrain themselves. Generally, self-restraint jumpers should be left in place if ZSI is not used or if the application requires delay time before tripping in the event of a short circuit and/or ground fault. See Table 4 for self-restraint jumper installation.

Table 5: Self-Restraint Connections

| Circuit Breaker Type/Series | Function (ST or GF) | Connect Terminal (Restraint IN) | To Terminal (Restraint OUT) |
|---------------------------------------|---------------------|---------------------------------|-----------------------------|
| LE 1B | Short-time | #5 | #6 |
| LE 1B | Ground-fault | #7 | #8 |
| PG, PJ, PL, RG, RS, RL and Masterpact | Both | Z3, Z4, Z5 | NA |

Ground-Fault Module (GFM) for H- and J-Frame Circuit Breakers

Figure 25: Ground-fault Module (GFM)



1. Ground-fault Test 120 Vac
2. Ground-fault Test 120 Vac
3. Neutral CT
4. Neutral CT
5. Ground-fault Shunt Trip Coil
6. Ground-fault Shunt Trip Coil
7. GF Restraint OUT
8. GF Restraint COMMON

06003014

Micrologic ground-fault modules (GFMs) have only a ZSI output terminal and a common terminal. They do not have a standard output terminal. These devices are meant to be used as the furthest downstream devices of the system and so will never need to receive a restraint signal.

Figure 26:

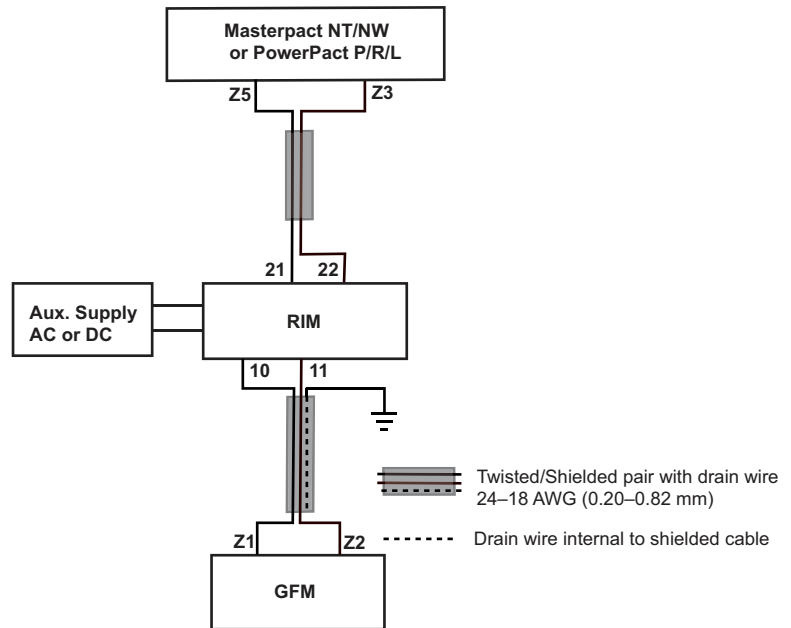

Restraint Interface Module (RIM) Usage

The Restraint Interface Module (RIM) serves two purposes in a ZSI system with Square D devices:

- It boosts the voltage level of the restraint signal.
- It converts the input and output restraint signals to allow different electronic designs to communicate with each other.

Table 6: ZSI Combinations

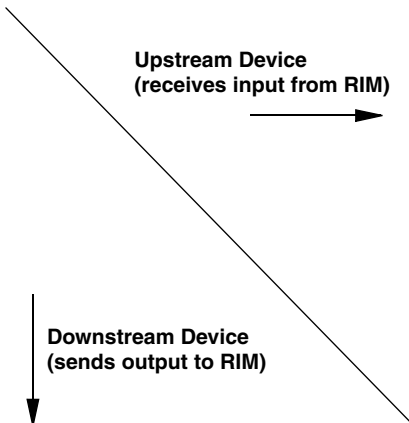
|  Upstream Device (receives input from RIM) | | | | | | |
|--|----------------------------|---|---|---|-------------------------------|---|
| | Micrologic #.0x Trip Units | Square D Micrologic Series B Trip Units | Square D GC-100 Ground-fault Relay for Equipment Protection | Square D GC-200 Ground-fault Relay for Equipment Protection | Merlin Gerin STR58 Trip Units | Federal Pioneer USRC and USRCM Trip Units |
| Micrologic #.0x Trip Units | 15 | R | R | 15 | 15 | R |
| Square D Micrologic Series B Trip Units | R | 26 | R | R | R | 15 |
| Square D GC-100 Ground-fault Relay for Equipment Protection | R | R | 7 | R | R | R |
| Square D GC-200 Ground-fault Relay for Equipment Protection | 15 | R | R | 15 | R | R |
| Merlin Gerin STR58 Trip Units | 15 | R | R | R | 15 | R |
| Merlin Gerin STR53 Trip Units | 15 | R | R | R | 15 | R |
| Federal Pioneer USRC and USRCM Trip Units | R | 15 | R | R | R | 15 |
| Square D Add-on Ground Fault Module for Equipment Protection | R | 5 | R | R | R | R |

R—RIM module is required to restrain any devices.
Numerical References—Maximum number of upstream circuit breakers which can be restrained without requiring a RIM Module.

Restraint Signal Voltage Boost

The voltage level of the restraint signal must be maintained at a certain level in order to activate the time delay on an electronic trip device. If the restraint signal is too weak to activate the time delay feature, all devices that sense the fault will trip with no intentional delay.

The voltage level of the restraint signal can be ineffective due to:

- Restraint wire length exceeding 1000 ft. (304.8 m)
- One device sending a restraint signal to too many devices
- Differing signal levels between different electronic trip systems

Voltage Drop

If the restraint wire length exceeds 1000 feet (304.8 m), the voltage drop along the control wire will weaken the signal until it can no longer activate the time delay on the upstream device. If wire length must exceed 1000 ft. (304.8 m), a RIM module must be placed in the circuit to boost the voltage level of the restraint signal.

Wiring ZSI Connections

Earth Grounding of Shielded Cables

- Maximum length of wire spliced to the drain wire of the ZSI lines and earth grounded = 10cm.
- Earth ground drain wire at only the end of the cable closest to the upstream circuit breaker.

Power Supply Connections/Requirements

When powering the RIM module with a 24Vdc power supply:

- Do not earth ground either the positive or the negative DC output of the 24 Vdc supply
- The 24 Vdc power supply can not be shared with accessories that are not galvanically connected to the RIM or circuit breaker trip units (i.e. shunt trip, shunt close, UVRs, etc.)
- The RIM module can share the same 24Vdc power supply as used to power the electronic trip units on either the upstream or downstream Powerpact H, J, or L frame circuit breakers

**Reducing Fault Stress with Zone-selective Interlocking
Data Bulletin**

Schneider Electric
3700 Sixth St. SW
Cedar Rapids, IA 52404 USA
1-888-778-2733
www.schneider-electric.us

Electrical equipment should be installed, operated, serviced, and maintained only by qualified personnel. No responsibility is assumed by Schneider Electric for any consequences arising out of the use of this material.

Square D™ and Schneider Electric™ are trademarks or registered trademarks of Schneider Electric. Other trademarks used herein are the property of their respective owners.

0600DB0001 R11/11 04/2012
Replaces 0600DB0001 11/2000
© 2000–2012 Schneider Electric All Rights Reserved