

# Transport and distribution inside an installation

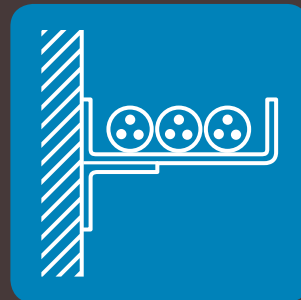

13

POWER GUIDE 2014 / BOOK 13

# INTRO

**The infrastructure for power distribution in the electrical installation is a very delicate issue. It functions exactly like the veins and arteries in the human body. A meticulous analysis of the requirements, together with a good choice of solutions, will make it possible to achieve greater versatility in the installation and will make power usage simpler. The choice of the power transport system, prefabricated busbar systems or trunking and cable trays, must guarantee the flexibility of the installation and the option for future extension.**

---

To design an electrical installation successfully, it is necessary to choose the power distribution system carefully so that it will respond best to the constraints of the installation. This involves in particular the transformer, the electrical panels and the power usage points. The advantages and disadvantages of the different solutions must be reviewed.

Choosing a power transport solution will allow the power to be directed to each installation point by a simple, functional and flexible method.

When choosing a system, the power used must of course be taken into consideration but so must other factors: ease of installation, flexibility of use and reconfiguration for all future extensions, as well as long term maintenance requirements.

Legrand solutions include an extensive range of products able to satisfy all needs for all applications.

The aim of this guide is to give all the information necessary to choose the best and most suitable solutions for your needs, to examine the different applications and to describe the characteristics and advantages of each of the solutions in the Legrand catalogue.

<b>Overall outline of the installation</b>	<b>02</b>
<b>Choosing power transport systems</b>	<b>04</b>
Power transported	06
1. High power	06
2. Medium power	07
3. Low power	07
Installation configuration	08
1. Conductor routing	08
2. Level of flexibility of the installation	10
3. Connections and junctions	12
External stresses	13
1. Business sectors and their specific stresses	13
2. Characteristics of products in light of external stress	24
<b>Further precautions and constraints</b>	<b>38</b>
Fire behaviour and construction safety precautions	38
1. Assessment of the fire risk	38
2. Fire behaviour of cables and conductors	38
3. Installation precautions	60
Electrical continuity and earthing	46
1. Cable tray	46
2. Prefabricated busbar trunking	48
Operating current and voltage drops	50
1. Prefabricated busbar trunking	50
2. Cables fitted in cable trays or ducts	52
Grouping conductors in parallel	53
Precautions for short circuits	56
1. Conductors in cable tray	56
2. Prefabricated busbar trunking	57
Precautions with respect to magnetic effects	58

Electromagnetic compatibility	59
1. Electrical continuity of cable trays	59
2. Reduction effects	62
3. Geometric separation of conductors and circuits	64
4. Electromagnetic screening of cable trays and prefabricated trunking	65
Permissible mechanical loads	69
<b>Prefabricated busbar trunking</b>	<b>70</b>
Architecture of an installation and choice of ranges	70
High power trunking	75
1. HR trunking	76
2. SCP trunking	80
Medium power trunking	90
1. MR trunking	90
2. MS trunking	94
3. TS trunking	96
Low power trunking	98
1. LB plus trunking	98
2. Easybar trunking	102
<b>Cable tray and ducting</b>	<b>104</b>
Overview	104
1. Cable ladder	104
2. Wire cable tray	104
3. Sheet metal or PVC cable tray	104
4. Ducting	105
5. Skirting trunking and mouldings	105
6. Floor ducting	105
Cablofil cable tray	106
1. General characteristics	106
2. System composition	106
3. Earthing	108
4. Partition feedthrough	108
5. Mechanical strength	108

# Overall outline of the installation

The electrical installation is a complex system which can present different constraints, according to the power to be supplied and the applications for the power. Generally, an electrical installation is a "hybrid" system with varied solutions, which allocates power transport to different systems according to type and the mechanical or electrical characteristics of the installation.

A complex electrical installation starts from the high voltage/low voltage transformer and spreads out through the building in a structured way. Its main function is to distribute electricity throughout all the spaces in the building in order to make it easily available. There are typically two types of power transport: cables and prefabricated busbar systems. According to requirements and common practice, each can use conductors in copper or aluminium. A very wide range of materials makes the installation of these two methods possible. The choice depends on the power transported, local use requirements and environmental stresses.

## INSTALLATION TREE STRUCTURE

An electrical installation must make it possible to distribute power from one or more sources to the end usage points. The levels of power transported vary according to the position in the installation:

- links upstream of the LV main distribution board
- distribution of power between the main and secondary LV distribution boards
- terminal distribution between the secondary distribution boards and the usage points.

## LINKS UPSTREAM OF THE LV MAIN DISTRIBUTION BOARD

For power connections such as the links between transformers, or between the transformers and the LV distribution board, above a certain power level, the use of prefabricated busbar systems is recommended. These busbar systems offer performance suitable for high power, together with compactness and safety.

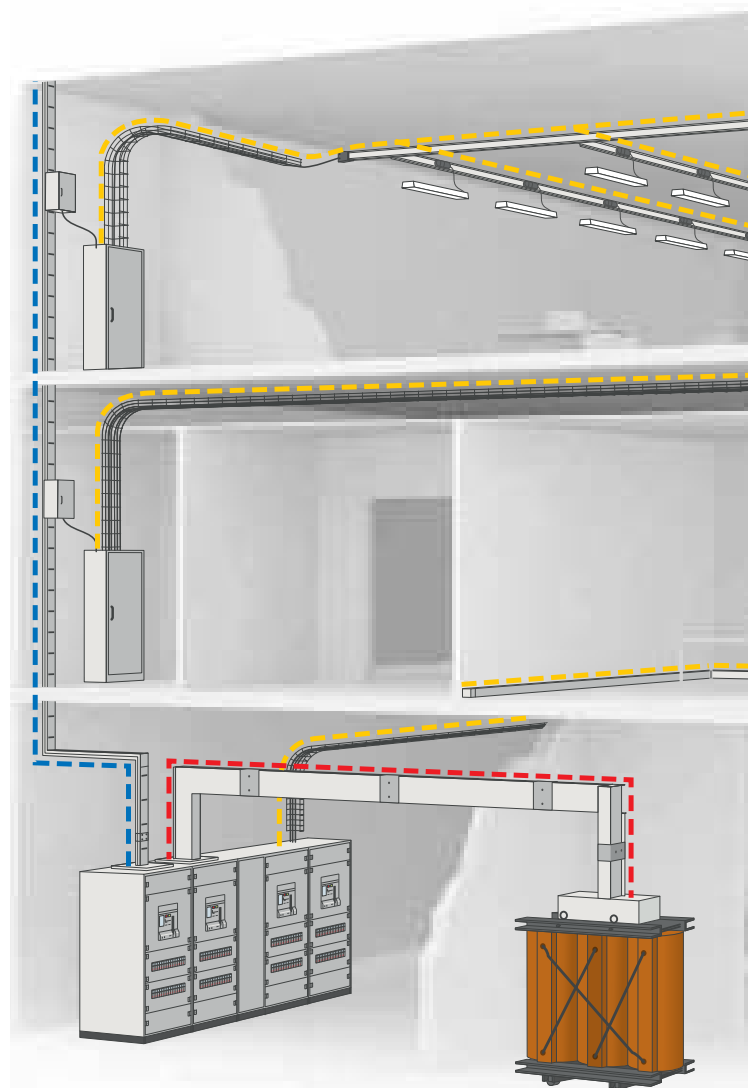

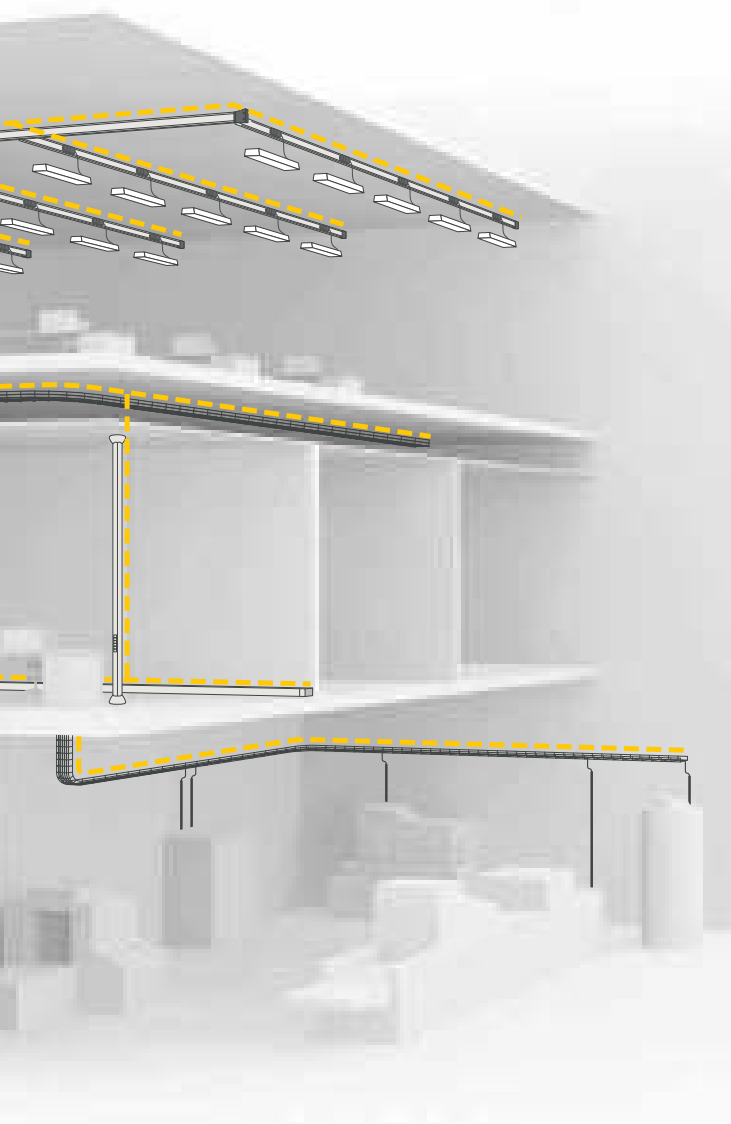

## POWER DISTRIBUTION BETWEEN MAIN AND SECONDARY DISTRIBUTION BOARDS

Power distribution between the main LV distribution board and the secondary distribution boards can be achieved by using prefabricated busbar systems or cable trays. The choice of one or other of these solutions depends on many factors. The power to be transported is the critical factor, the other selection criteria depend on the applications and the installation environment.

## TERMINAL DISTRIBUTION

Power distribution from the secondary distribution boards to the terminal boxes, or to the workstations is often achieved with trunking or cable trays which are more suitable for complex routing than prefabricated busbar systems. The same methods also allow the distribution of copper or fibre optic data cables. Trunking and cable trays are not the only transport methods suitable for terminal distribution. There is in fact a great variety of products: mini trunking, skirting, cornice trunking, columns, platform floors, low power prefabricated busbar systems, etc.

### < Example of electric tree structure:

- - - - - Transformer - main LV distribution board link (high power)
- - - - - Main LV distribution board - secondary distribution board links (medium power)
- - - - - Terminal distribution (low power)

# Choosing power transport systems

There is no single model for electricity transport within the same installation. Whether in a commercial building or at an industrial site, several systems are used and often coexist according to the power to be transported, the distribution requirements (flexibility, options for routing, joining and connecting, etc.) and the environmental conditions connected with the specific stresses in different business sectors.

Three key starting points predominate when choosing electricity transport methods.

- 1 - The power to be transported from the source to the usage point (see page 06)
- 2 - The routing and the distribution configuration, which must be tailored differently according to the application (see page 08)
- 3 - The adaptation of the system or systems selected (prefabricated busbar systems or cable trays) for the stresses of the place of use (see page 13). These stresses are for the most part specific to each business sector but it is often necessary to go further when identifying them, by knowing about the specific application.



^ Coexistence of different power transport systems in the same installation

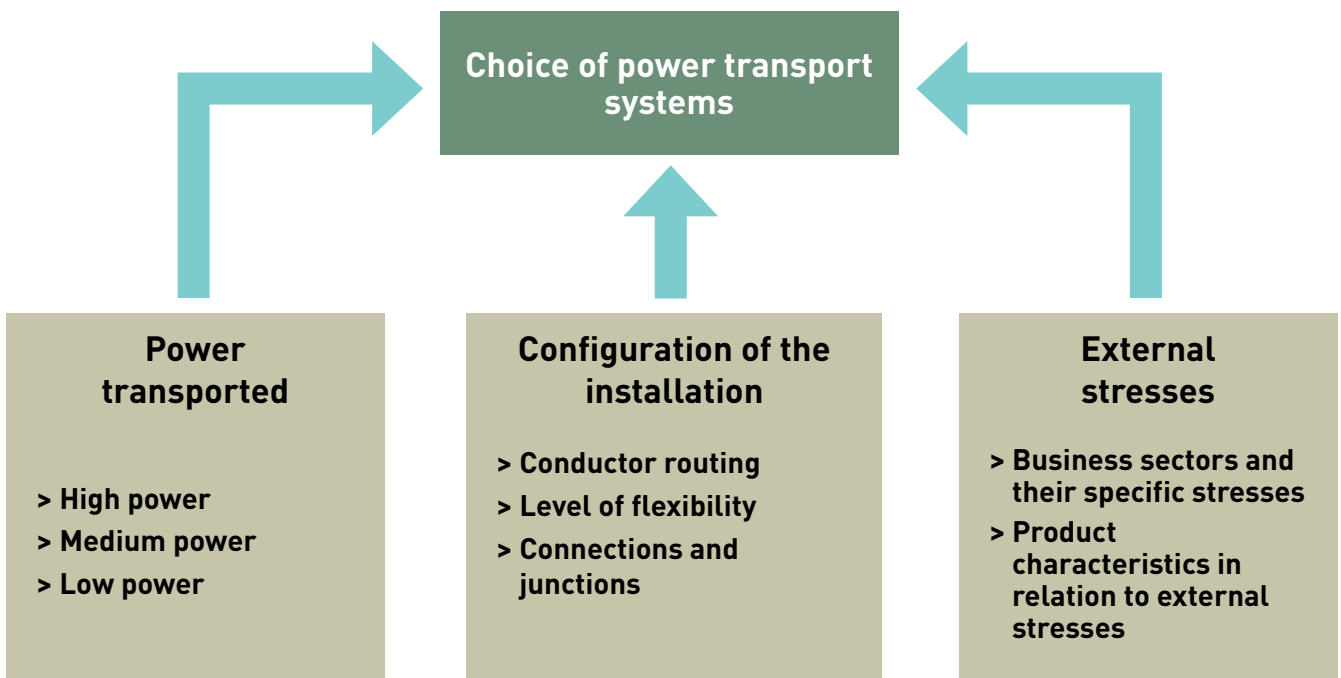

## Cable trays or prefabricated busbar systems?

These two systems are used in the infrastructure for transporting and distributing electric power, regardless of the destination: industrial or commercial sites, service sector establishments or residential buildings.

The most classic system uses insulated conductors or cables which are supported by mechanical devices: cable ladders, trunking, cable trays and ducts that can offer multiple configurations, shape and build options allowing them to be adapted to different premises and environments.

The existence of numerous types of conductors suitable for the majority of stresses (temperature, immersion, chemical substances, vegetation, fire, UV, etc.) means that cable trays can be installed in almost any environment. The limit on this system is a result of the maximum operating current (multiple conductors) or the electrical requirements (short circuit and magnetic radiation).

Prefabricated busbar systems are both an alternative and a complementary system. Conductors are grouped together and isolated in the same enclosure, which supports and protects them.

These integrated systems, perfectly calculated from an electrical and electromagnetic point of view, allow the flow of very high power and give very high levels of protection against specific stresses: IP, fire, electromagnetic radiation.

Integrating them into the infrastructure of the building requires preliminary consideration to ensure that optimum solutions are selected. Specific rules must be followed for installation and assembly.

Prefabricated busbar systems are generally classified as "high power", "medium power" and "low power". They allow all types of power transport from the power source to the end usage point (workstations, machines, lighting, etc.).

Cable trays and prefabricated busbar systems are two different systems, each with its own advantages. Of course, their use can also depend on common practice. Naturally, the two systems are complementary and can be installed at different levels, or for different usages at the same site.



## Standards and approvals

- IEC 61537: Cable management - Cable tray systems and cable ladder systems
- IEC 61439-2: Low voltage switchgear and controlgear assemblies - Part 6 : Busbar trunking systems (busways)
- EN 50085-1: Cable trunking systems and cable ducting systems for electrical installations - General requirements
  - Part 2-1: Cable trunking systems and cable ducting systems intended for mounting on walls and ceilings
  - Part 2-2: Particular requirements for cable trunking systems and cable ducting systems intended for mounting underfloor, flushfloor, or onfloor
  - Part 2-3: Particular requirements for slotted cable trunking systems intended for installation in cabinets

# Choosing power transport systems (continued)

## POWER TRANSPORTED

The choice of an energy transport system depends firstly on the power level. At each level of the installation, it is important to know the maximum current, as determined by the power balance (see Book 2). Cable trays and prefabricated busbar systems do not conflict but complement each other to create a high performance installation. Three levels can be distinguished: high power, medium power and low power.

### 1 HIGH POWER

For very high currents (above 1000 A), the use of cables can be inappropriate and not cost-effective and the use of cable trays can become complicated from a technical point of view. The use of cables with large cross-sections clearly requires trunking or large sized cable trays. Moreover, because of the weight of the cables, fixing devices must also be

suitable for the load. Curves and changes of direction must also be taken into consideration. The minimum bend radius depends on the cross-section and the number of cables installed. The use of very large cables necessitates a wide bend radius which causes a significant loss of volume. In these conditions, trunking or cable trays are therefore less easy to install but they are nevertheless commonly used. Faced with these constraints, prefabricated busbar systems are more appropriate. A busbar, by its very nature, is designed to carry a high current in a reduced space and is certain to satisfy all the technical demands required for high power transport. Usually, the links between the transformers and the main LV distribution boards are made with high power prefabricated busbar systems. But links between the main LV distribution board and the medium power secondary distribution boards can also be made by prefabricated busbar systems, according to the distance between the boards. Cable trays are more suitable for large lengths (several dozen metres).



**The nominal current values below are commonly used to choose different transport solutions.**

	Low	Medium	High
Busbar	< 160 A	160 to 1 000 A	1 000 to 5,000 A
Cables	< 63 A	63 to 630 A	630 to 2,000 A

< Link between the transformer and the main LV distribution board by Legrand high power prefabricated busbar system

## 2 MEDIUM POWER

Generally, medium power links involve distribution between the main distribution board and the secondary distribution boards, and between the secondary distribution boards and terminal boxes, according to the number of levels in the installation. Prefabricated busbar systems, trunking and cable trays are used interchangeably to transport currents of several hundred amps. The choice is made according to the configuration of the installation (routing, flexibility, etc.) and the external stresses. For example, when good mechanical resistance and dustproofing are required, closed trunking can be used.

Prefabricated busbar systems can also be used in the same conditions if there is a space problem.

## 3 LOW POWER

Currents with an intensity of around 100 A are generally distributed by cable trays or trunking, even if prefabricated low power busbar systems are used increasingly often. Low power links are usually located between secondary distribution boards and usage points. They are created with distribution systems in ceilings (suspended or not), on walls, in false floors or more often in technical areas.

Low power distribution is also involved in powering workstations. Numerous systems are available to provide solutions that are perfectly adapted to the specific requirements of each usage: aluminium columns, plastic or aluminium trunking, floor boxes, etc. Offering options for both power distribution and connection flexibility, prefabricated busbar systems are a suitable system to power lighting in industry and the service sector.



^ Metal cable trays with wall feedthroughs



^ Legrand LB low power prefabricated busbar systems in a sewing workshop

# Choosing power transport systems (continued)

## INSTALLATION CONFIGURATION

The term installation configuration, when applied to power transport and power distribution in the installation, essentially refers to the geometric requirements of the conductor routing that will have to be taken into consideration. Adaptability requirements may also be added to these considerations, particularly at the level of connection of usage points which must have the required flexibility (for example frequent disconnections or changes).

### 1 CONDUCTOR ROUTING

To design a power transport system, it is necessary to have an overall vision of the routing to be achieved, paying particular attention to changes of direction, obstructions (partitions, fire breaks, doors, etc.) or obstacles (pillars, walls, etc.), which must be avoided without any interruption in the continuity of the conductors. With this approach, it is recommended that a site inspection be carried out before the project in order to evaluate the routing problems. If this is not possible, a study will be made "on the blueprint". The choice of a cable tray or prefabricated busbar system must be compatible with the routing required, without forgetting to check that the accessories necessary for changes of direction, to avoid obstacles, for alterations of level and feedthroughs are actually available. Moreover, it is necessary to give consideration to the characteristics of the floor tiles or the walls (for example reinforced concrete), the difficulty in securing supports, as well as the size and weight of the cable trays or prefabricated busbar systems. The cross-section and number of cables to be installed can also be an important variable for consideration. The greater the number of cables and the wider their cross-section, the closer together the supports must be. The minimum bend radius must also be considered.

The same considerations also apply to prefabricated busbar systems with their own characteristics. At this stage, dimensions can be a decisive element when making choices.



^ Example of routing of prefabricated busbars and cable trays

With a global approach to conductor routing, it is also necessary to consider the other services in the building that could be an interference: water, gas, smoke conduits or ventilation, air conditioning, fire systems and other networks in general. Some sensitive sites (airports, data centres, high technology industries, etc.) require a second duct for power transport and distribution which must be separate for the safety of property and people, with the aim of ensuring continuity and/or segregation in the case of a fire risk.

### 1.1 Dimension and size of the distribution system

The height and the width of the ducting chosen must be suitable to contain the cable bundles, potentially in several layers. It is not recommended that more

than 50% of the total cross-section of the ducting be filled. It could be necessary, for example, to choose narrow cable trays or trunking with high sides for long runs, or wide cable trays or trunking with low sides to install cables in a reduced number of layers. In every case, there must be a study to facilitate the installation of trunking and laying of cables. If the space available is limited, it is interesting to examine a "prefabricated busbar system" solution which generally offers more compactness.

### 1.2. Bend radius

The minimum bend radius can be a limitation on the installation and this must be taken into account. It depends on the cross-section of the cables and the number of cables that must be installed without stress. Planning for a minimum bend radius at least equal to 6 or 8 times the exterior diameter of the largest cable is recommended. Prefabricated busbar systems have special parts (elbows) which allow less cumbersome changes of direction than are possible with trunking and cable trays.

### 1.3. Mechanical resistance

The conduit must be capable of supporting the weight of the cables it contains. It is necessary to check the maximum load certified by the manufacturer and to comply with it strictly. Ducts for heavy loads can allow a reduction in the number of supports, whereas light ducts will require numerous fixing points. The number, type and quality of supports (wall and/or ceiling supports) must be calculated when looking at the total cost of the installation. Prefabricated busbar systems are self-supporting solutions that give more rigidity to the installation. It is particularly important to check the availability of all the parts and accessories needed to create the links, down to the smallest detail.



^ The configuration of the site, obstructions, the co-existence of different networks sometimes lead to complex routing

# Choosing power transport systems (continued)

## 1.4. Specific installation requirements

In addition to the requirements of sizing, fitting shape and mechanical resistance related to conductor routing, each installation situation generally requires the study and implementation of particular precautions. In the majority, these precautions are connected with the local environmental conditions, classified in the broadest sense by the standards bodies as "external influences". These conditions, defined by standard IEC 60364-5-52, characterise mechanical stresses (impact, vibration, earthquakes, etc.), climatic stresses (temperature, humidity, etc.) to which are added a certain number of specific stresses, such as wind, sun, corrosion, fire risk, etc. All these stresses have been grouped into a classification giving them a level of severity according to business sector (see table page 14). For ease of reading, this table does not follow the organisation of the standard exactly. It has been adapted for power ducting, cable trays and prefabricated busbar systems, particularly by giving concrete examples of applications for different business sectors. As a function of this first analysis, a second table on page 16 makes it possible to determine the characteristic required for the products and/or the additional protection to respond to the stress.

## 2 LEVEL OF FLEXIBILITY OF THE INSTALLATION

The choice of a power transport system in a building must also allow for any potential modifications, developments and extensions of the installation. If these requirements exist, solutions must be chosen that offer good installation flexibility and guarantee continuity of service. The system chosen must be able to direct power where it is needed, without having to cut the power for long periods. Ease of installation is also important in order to minimise the time required to modify the system and to ensure quick and safe maintenance. With this in mind, the choice must take into consideration operations that could affect the production costs or management of the system. As the installation evolves, prefabricated busbar systems guarantee continuity of service by allowing connections and disconnections with the power on. On the other hand, it can be less costly to install trunking or cable trays in installations that do not require any particular modifications or maintenance.



**The choice of a distribution system is not limited to a single solution. According to the complexity and size of the building, the power used, the configuration of the location and the environmental conditions, prefabricated busbar systems, trunking or cable trays can be jointly used.**



## Lighting distribution

Lighting can be distributed in industrial or commercial buildings by using prefabricated busbar systems or cable trays with light fittings connected to them. Prefabricated busbar systems are an efficient and adaptive solution. The most common configuration (see illustration below) incorporates a main busbar onto which the independent lighting lines are connected. The busbar must be sized according to the number of lighting points and connections. Extending or reconfiguring the circuits, if necessary, will be much easier than with an equivalent solution created with trunking or cable trays. The use of prefabricated busbar systems is especially attractive if the installation requires adaptability and quick maintenance.

Lighting can also be powered with cables running in cable trays or trunking. In this case, each row of light fittings needs specific power cables that converge towards an electrical panel. The larger the lighting installation, the more complex its installation. In addition, if the circuits have to be reconfigured, this operation can also prove to be complex.

In small and medium sized installations, cable trays or trunking are generally used more frequently than the more expensive prefabricated busbar systems. Conversely, prefabricated busbar systems are a more suitable solution in large installations. The choice of one or other solution depends on technical and economic criteria but the two solutions must always be seen as complementary.

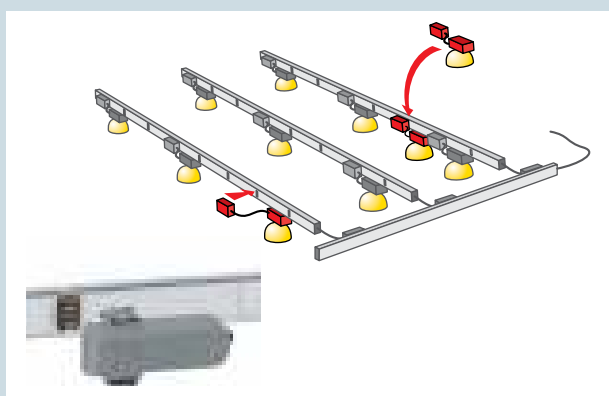

^ Lighting powered by prefabricated busbar systems

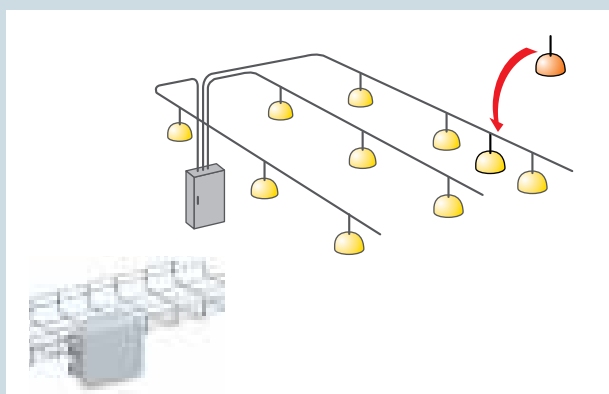

^ Lighting powered by cables in cable trays

# Choosing power transport systems (continued)

## 3 CONNECTIONS AND JUNCTIONS

The electrical installation must be designed and installed taking into account the need for modification and extension. This means that a flexible system must be installed, which must allow connections to power future uses. Cables and prefabricated busbar systems must be sized to take account of possible extensions and must allow new junctions. With a "cable" solution, connection equipment, such as distribution boxes and panels, must be installed at pre-defined points along the main line. This equipment, which could potentially be fitted with protection or isolation devices, will be able to power the starting points of the additional lines. With the "prefabricated busbar system" solution, the busbars used as main lines are fitted with connection points. In this case, to power new lines, junction boxes simply have to be fitted directly onto the busbar. If required, these junction boxes will be equipped with protection or isolation devices. Similar precautions will be taken at terminal circuit level to ensure maximum flexibility, should there be changes in the layout of workstations and/or an extension.

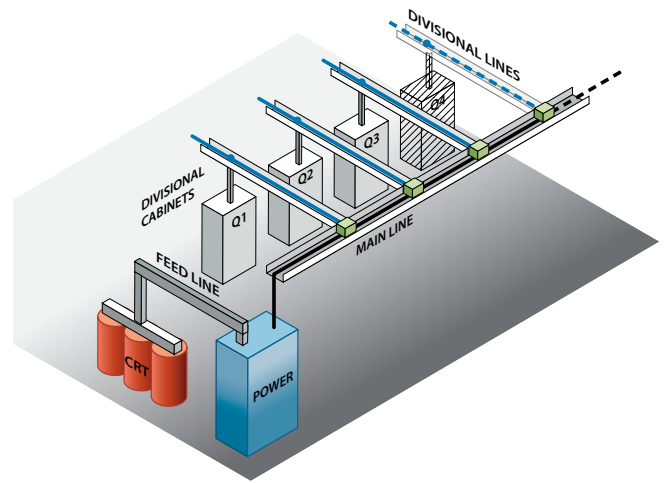

^ "Cable" solution: addition of a new distribution board to a junction box provided for this purpose

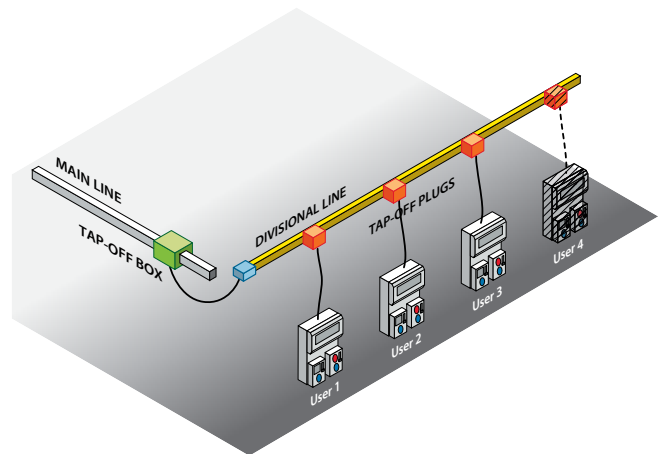

^ "Prefabricated busbar system" solution: addition of a new workstation by direct connection with the busbar system

## EXTERNAL STRESSES

Along with design requirements for transported power and the configuration of the installation, environmental conditions must be a factor in the choice of solutions for the transport and distribution of energy. They can be very different within the same installation and this can lead to tailored solutions.

### 1 BUSINESS SECTORS AND THEIR SPECIFIC STRESSES

Each specific application in a business sector can be subjected to a variety of stresses that will require a choice of different solutions and their coexistence. Taking the example of a shopping centre, the installation can originate with high power prefabricated busbar systems installed in equipment rooms. Then, distribution to different sectors of the building can be achieved with medium power prefabricated busbar systems (for example, via corridors or service trunking). Terminal distribution can be with low power busbar systems to power individual equipment and lighting. Cable trays can also be used to ensure medium and low power distribution to different usage points (cash tills, refrigerator units, preparation areas, cooking equipment, etc.) On an industrial site, the same global approach can produce totally different solutions. For example, terminal distribution can be subjected to very high stresses due to the process involved (vibration, chemical aggression, etc.) which do not exist in a shopping centre or an office situation. Beyond the overall guidelines, the majority of sites or buildings require a mixture of power transport, power distribution and terminal distribution systems with different solutions: prefabricated busbar systems, cable ladders and trays (wire, sheet metal, PVC), trunking, columns, conduits, etc. Standards bodies restrict themselves to a global consideration of the environment (see box). But in reality, this is very often insufficient and the specific stresses relative to each installation must be identified more precisely for each application. A more detailed breakdown is needed.

The tables on the following pages make it possible to take this approach in two phases. The first (page 14) is a classification where the different business sectors (agriculture, public works, services, etc.) are divided into eleven categories, with a more precise list of specific, representative applications for each of these sectors. The specific stresses (impact, temperature, presence of water, pollution, etc.) that are connected with these applications are classified with a number (and a colour) making it possible to identify the severity (low, medium or high) of each particular stress. The second phase of this approach (see table page 16) is intended to define more precisely the performance level and characteristics required, that enable the products to respond to the pre-identified stress. The choice of a suitable product then becomes a natural part of this process. NB: the classification deliberately only has three levels (low, medium, high) to correspond with the levels of stress and to make a choice easier in the vast majority of cases. The definition of more precise levels may be needed in some cases and can require a more detailed reference to the standards, particularly IEC 60721.



**Defining a medium stress level makes it possible to choose products taking into account the requirements of standard IEC 60364. This stipulates that materials must be chosen with regard to external influences, not only to ensure correct functioning but also to ensure the reliability of protective measures installed to guarantee safety. Protective measures associated with the manufacture of materials are suited for declared external stresses, provided that tests have been carried out for such conditions.**

# Choosing power transport systems (continued)

Level of stress according to business sector					
Classification of business sectors		Mechanical stresses			
		Building structure	Mechanical impacts	Vibration and acceleration	Seismic effects
Agricultural	Greenhouses	2	2	1	1
	Grain silos, flax mills	1	1	2	3
	Sugar refineries, wine cellars	1	2	1	2
	Sheds, storage	2	1	1	2
	Garages, workshops	1	2	1	1
Construction and public works	Energy supply to sites	3	3	3	1
	Quarries, cement works	2	3	3	1
Exterior services and infrastructure	Public lighting	3	3	2	2
	Railway network	3	3	3	2
	Covered markets	2	2	1	2
	Covered car parks	2	2	3	2
	Wash areas	1	3	2	1
	Stations and airport buildings	3	1	2	3
	Tunnels	2	2	3	3
Naval and ports	Cranes, transporters	3	3	3	2
	Leisure installations, marinas	2	3	1	1
Public buildings, commerce and service sector	Offices and administrative premises	1	1	1	1
	Hospitality premises, shopping centres	2	1	1	2
	Apartment blocks, hotels	2	1	1	2
	Healthcare institutions, hospitals, retirement homes	1	1	1	3
	Museums, libraries, archives	2	1	1	2
	Swimming pools	1	1	1	1
	Cinemas, entertainment halls	2	1	1	2
	Marquees	3	2	2	2
	Dance halls, basements	1	1	1	2
Agri-foodstuffs	Abattoirs, breweries, dairies, canning industry	1	2	2	1
	Fisheries, salting plants, auction markets	1	3	2	1
Chemical industry	Fertilisers, paints, solvents	1	2	2	2
	Water treatment	1	2	2	2
	Electroplating	1	3	3	2
	Oil industry, refineries, filling stations	2	2	2	3
	Pharmaceuticals, fine chemicals	1	1	1	2
Processing industry, workshops	Packaging machinery	1	2	2	1
	Assembly lines	2	2	2	1
Heavy industry	Metal work, mechanics	1	3	3	1
	Steel industry	1	3	3	2
High technology industry	Nuclear industry	1	1	1	3
	Aeronautics	1	1	1	1
	Electronics, communications	1	1	1	1
Onboard applications	Railways	1	3	3	3
	Ships	1	3	3	1

1 Low level of stress     
 2 Medium level of stress     
 3 High level of stress

	Climatic stresses			Additional stresses				Special stresses		
	Temperature	Moisture	Presence of water	Presence of corrosive and polluting substances	Presence of dust	Presence of flora or moulds	Presence of fauna	Solar radiation	Risk of fire or explosion	Electromagnetic or electrostatic fields
	3	3	3	2	1	3	2	3	1	1
	3	1	1	1	3	3	3	1	3	3
	2	2	2	2	2	3	2	1	3	1
	1	2	1	1	2	2	3	2	2	1
	1	1	1	2	2	1	1	1	2	1
	3	3	3	2	3	1	2	3	1	1
	3	3	3	3	3	1	1	3	1	1
	3	3	3	2	2	3	3	3	1	1
	3	3	3	2	3	3	2	3	1	3
	3	2	2	1	1	3	2	2	1	1
	1	2	2	1	2	2	2	2	3	2
	3	3	3	2	2	2	1	3	1	1
	1	2	2	1	3	2	2	2	2	2
	1	2	2	2	3	2	3	1	2	2
	3	3	3	1	2	1	1	3	1	2
	3	3	3	2	1	2	2	3	1	1
	1	1	1	1	1	1	1	1	1	1
	1	1	1	1	1	1	1	2	2	1
	1	1	1	1	1	1	1	1	2	1
	1	1	1	1	1	2	1	1	2	3
	1	1	1	1	1	2	1	1	2	1
	1	3	3	3	1	1	1	2	1	1
	1	1	1	1	1	2	1	1	2	1
	2	2	1	1	1	1	1	1	2	1
	1	2	1	1	1	2	1	1	2	1
	3	3	3	2	1	2	2	1	1	1
	2	3	3	3	1	2	2	2	1	1
	2	2	2	3	3	1	1	1	3	1
	2	3	3	3	1	2	2	1	1	1
	2	2	3	3	2	1	1	1	2	1
	3	3	2	3	3	1	1	3	3	2
	1	1	1	2	1	1	1	1	3	2
	1	1	1	1	2	1	1	1	1	1
	1	1	1	1	2	1	1	1	1	2
	2	1	1	2	3	1	1	1	1	1
	3	2	1	2	3	1	1	1	2	1
	2	2	1	1	1	1	1	1	2	3
	1	1	1	1	1	1	1	1	1	2
	1	1	1	1	1	1	1	1	1	3
	3	3	2	2	3	1	1	2	3	3
	2	3	3	3	2	2	1	2	3	2

# Choosing power transport systems (continued)

Required product characteristics according to the level of stress				
Risks		Level	Code IEC 60364-1	Characteristics of the installation, risks or specific stresses
Mechanical stresses	Shifting or movement of building structures	1	CB1	Limited risk, rigid structures and small installations
		2	CB3	Potential risk (long buildings, cross beams, bridges, etc.)
		3	CB4	Significant risk, flexible or unstable structures (marquees, cranes, suspended parts, etc.)
	Mechanical impacts	1	AG1	Low risk in residential, commercial installation or similar
		2	AG2	Medium risk in normal industrial conditions
		3	AG3, AG4	High (AG3) or very high (AG4) risk in harsh industrial conditions Special applications on public roads, car parks
	Vibration and acceleration	1	AH1	Negligible effects in residential, commercial installation or similar
		2	AH2	Significant effects in normal industrial conditions
		3	AH3	Severe effects in harsh industrial conditions or similar (e.g. road or railway systems)
	Seismic effects	1	AP1, AP2	Low to medium seismic risk - Zone UBC 1 and 2 (ground acceleration: 2 m/s <sup>2</sup> )
		2	AP3	Medium to high seismic risk - Zone UBC 3 (ground acceleration: 3 m/s <sup>2</sup> )
		3	AP4	Strong to very strong seismic risk - Zone UBC 4 (ground acceleration: 5 m/s <sup>2</sup> )
Climatic stresses	Temperature	1	AA4, AA5	Normal interior conditions including unoccupied buildings, sheds
		2	AA3 to AA5	Normal interior or exterior conditions in temperate areas
		3	AA3 to AA8	Extensive harsh interior or exterior conditions
	Moisture	1	AB4, AB5	Dry or moderately dry environment Interior installations with or without temperature control
		2	AB6, AB7	Humid or potentially humid environment Protected interior or exterior installations
		3	AB8	Very humid environment - Unprotected exterior installations
	Presence of water	1	AD1	No water or drops of condensation falling Interior environment
		2	AD2, AD3	Brief sprinkling of water possible, condensation and dripping water. Sheltered interior or exterior environment
		3	AD4 to AD6	Rain and washing jets - Exterior installations
Heavy seas, waves and high pressure washing Very exposed exterior installations Risk of temporary immersion, unusual tidal range, floods				

**Minimum level of product performance and installation instructions**

No specific requirement
Provide expansion joints, flexible couplings - Increase the number of supports in the vicinity of movement points
Design adapted to allow freedom of movement: flexible busbars
Impact energy max 0.2 joules, min IK02 products
Impact energy max 2 joules, min IK07 products
Impact energy max 5 joules, min IK08 products
Impact energy max 20 joules, min IK10 products
Sinusoidal vibrations peak/peak 1.5 mm - 2 to 9 Hz, 5 m/s <sup>2</sup> - 9 to 200 Hz, accelerations impacts 70 m/s <sup>2</sup> - 22 ms No specific precaution
Sinusoidal vibrations peak/peak 7 mm - 2 to 9 Hz, 20 m/s <sup>2</sup> - 9 to 200 Hz, accelerations impacts 100 m/s <sup>2</sup> - 11 ms Flexible assemblies, locking or anti-slip fixings
Sinusoidal vibrations peak/peak 15 mm - 2 to 9 Hz, 50 m/s <sup>2</sup> - 9 to 200 Hz, accelerations impacts 250 m/s <sup>2</sup> - 22 ms Specific precautions - Preliminary studies and tests recommended
Floor acceleration: 20 m/s <sup>2</sup> Clamping of conductors Adherence to fitting rules (as per CB3)
Floor acceleration: 30 m/s <sup>2</sup> Reinforced anchoring, limit loads (by a min factor of 3) and overhangs
Floor acceleration: 50 m/s <sup>2</sup> - Special anchors (seismic-rated bolts), low level installations if possible and strict load reduction (min factor of 5) - Preliminary study and tests recommended.
Ambient temperature range -5°C to +40°C - IEC 60721-3-3 Conditions 3K3, 3K4, 3K5
Ambient temperature range -25°C to +55°C - IEC 60721-3-3 Conditions 3K6
Ambient temperature range -25°C to +70°C - IEC 60721-3-3 Conditions 3K7 Avoid thermoplastic cable ducts
Absolute humidity ≤ 28 g/m <sup>3</sup> - IEC 60721-3-3 Conditions 3K3, 3K5 Normal protection against corrosion
Absolute humidity >28 g/m <sup>3</sup> ≤ 35g/m <sup>3</sup> - IEC 60721-3-3 Conditions 3K6, 3K7 Increased protection against corrosion
Absolute humidity > 35g/m <sup>3</sup> - IEC 60721-3-3 Conditions 3K7, 3K8 - Very high protection against corrosion
IP X0
IP X2/IP X3 - Away from walls, care with installation in relation to water channels
IP X4/IP X5 Installation of water drains, curved cables, additional protection if necessary
IP X6 Enhanced weatherproofing
IP X7/IP X8

# Choosing power transport systems (continued)

Required product characteristics according to the level of stress (continued)				
Risks		Level	Code IEC 60364-1	Characteristics of the installation, risks or specific stresses
Additional stresses	Presence of corrosive and polluting substances	1	AF1	Few corrosive agents - Dry or momentarily damp interior installations
		2	AF2, AF3	Significant presence of corrosive agents Damp and moderately corrosive interior installations Standard exterior installations
		3	AF4	No significant presence of dust Possible presence or fall of small objects
	Presence of dust	1	AE1 to AE4	No significant presence of dust Possible presence or fall of small objects
		2	AE5	Limited presence of dust > 35 mg/m <sup>2</sup> /day
		3	AE6	Significant presence of dust ≤ 350mg/m <sup>2</sup> /day or very significant > 350 mg/m <sup>2</sup> /day
		1	AK1	No risk
	Presence of flora and moulds	2	AK1+	Increased risk
		3	AK2	Significant risk of flora and moisture (agri-food, tropical atmosphere)
		1	AL1	No specific risk
	Presence of fauna	2	AL1+	Possible presence of rodents or insects
		3	AL2	Presence of termites
Special stresses		Solar radiation	1	AN1
	2		AN2	Sheltered exterior exposure
	3		AN3	Exterior exposure to direct sun and precipitation
	Fire or explosion risks	1	BE1	Normal risk
		2	BE2, CB2	Increased risk of fire (premises classed as at risk of fire) and of fire spread (very tall vertical ducts)
		3	AM	Risk of explosion in certain premises classified according to their activity or the nature of the materials handled or stored
	Electromagnetic or electrostatic fields	1	AM8-1	Low emission level, little electromagnetic interference, commercial or residential installation according to IEC 61000-6-3
		2	AM8-2	Medium or high emission level, potential significant interference, industrial environments according to IEC 61000-6-4
		3	AMx	Very high emission level, significant or very significant level of interference Power units, control units, level according to specification

**Minimum level of product performance and installation instructions**

Corrosion class C1 or C2 - Products in zinc-plated steel

Corrosion class C2 or C3 - Products in galvanised steel or stainless steel

Corrosion class C4, C5M, C5I - Products in stainless steel

Min IP 2X

IP 3X or IP 4X particularly on the top of ducts - Provide covers if necessary

IP 4X or IP 5X - Provide covers

IP 5X or IP 6X

IP 6X

No specific requirement

Encourage ventilation. Avoid water retention - Use of metal ducts

Use of stainless steel ducts

Normal hygiene at premises - Trapping and bait

Increased degree of protection IP 4X - Rodent-resistant cables

Degree of protection IP 5X - Resistant cables and use of metal ducts exclusively

Test method ISO 4892-2 - Method B - Min test level 250 h

Test method ISO 4892-2 - Method B - Min test level 500 h

Test method ISO 4892-2 - Method A - Min test level 2500 h.  
Materials recognised as UV resistant or metal cables. Protective covers

Category C2 conductors

Category C1 conductors according to IEC 60332-3 - Precautionary layout for conductor bundles, limited heat load, treatment of wall feedthroughs, fire retardant ducts

Separation of premises - Material for explosive atmospheres - Power ducts fully protected against risk of impact, mechanical impact, chemical action and all deterioration

Immunity level compliant with standard IEC 61000-6-1 - Compliance with electrical continuity precautions

Immunity level compliant with standard IEC 61000-6-1 - Metal cable trays and/or screened or shielded conductors

Reinforced immunity level - Closed metal cable trays and/or shielded cables, physical separation and distancing of data conductors and power conductors, interference suppression filters if necessary

# Choosing power transport systems (continued)

## Comments and further details on stresses

**Warning:** the table showing stress levels according to business sector (page 14) and the following comments clarifying this table are for guidance in order to give an indication of the stresses generally found in the different locations or premises referred to. It does not replace standards, regulations or specifications which can specify different requirements.

### > Mechanical stress

#### • Shifting or movement of building structures

The issue of rigidity links the need for structural resistance in cable trays or prefabricated busbar systems, which depends on the design of the product and its supports, with the rigidity of the building or the structure to which they are fixed. In other words, the rigidity and strength of the cable trays or busbars can be reinforced by the surrounding structure (level 1) or become distorted by it (level 3); this can necessitate specific precautions when fixing.

It is essential to follow the construction rules, that set the distances between supports, and the requirements for assembly (fish-plating), in order to achieve a flex resistance that is appropriate for the permissible load (see page 69).

Particular care is needed with cut-outs and machining which can cause a mechanical discontinuity and a weakening of the cable trays. The intrinsic structural rigidity of the prefabricated busbars makes this aspect less critical, however their significant weight can be a limit in lightweight constructions.

#### • Mechanical impacts

Mechanical impact risks are primarily connected with the activity at the location or premises. Certain locations are described in the standards as risk areas for significant impacts: vehicle traffic areas, work sites, heavy industry, pavements, exterior services, etc. But cable ducting in other premises

(e.g. warehouses) can also suffer significant accidental impacts, particularly as a result of maintenance. Installation or repair in extreme cold creates particular stresses, because cables stiffen and certain materials (rigid PVC, for example) become brittle. Closed cable trays have better impact resistance than wire cable trays, where the conductors are exposed.

#### • Vibration and mechanical impact

The level of vibration transmitted to cable trays or prefabricated busbar systems is generally quite low in the majority of power distribution installations in buildings. However, it increases in proximity to points of use: machines, travelling cranes, road or rail infrastructure. Onboard applications (ships) are also particularly exposed. Vibration can cause loosening or even cracks or breakages. Screwless assembly systems and fish-plating are well suited to vibration.

#### • Seismic effects

Consideration of seismic stresses on cable trays and prefabricated busbar systems is, above all a matter of common sense. Risk analysis can only be undertaken with knowledge of the presumed behaviour of the buildings or structures whose movements will carry along with them the conductor ducts which are fixed to them (see Book 8 for further details). Cable trays can suffer significant distortion. Wire cable trays have a more elastic performance. If the conductors are installed without excessive clamping, they will generally be able to follow movements generated without breaking. The earth for high power busbar systems is a significant inertial potential that can be shifted by seismic movements, with consequences that are all the more significant because they are at the supply end of the installation. They will require a special fixings design (type and number of supports).

## > Climatic stresses

### • Temperature

Temperature conditions have a direct influence on the power transport capacity of cable trays or prefabricated busbar systems. In an environment above 40°C, it may be necessary to apply a reduction factor to the current-carrying capacity. The cooling conditions (open or closed cable trays) must be considered, along with the arrangement of cable bundles. Prefabricated busbar systems are less dependent on this aspect, as their performance is little affected by the installation. Some conductor ducts in thermo-plastic materials (PVC, ABS, etc.) can reach their limits with higher temperatures (above 70°C), as can conductors and cables, which must therefore be chosen with this in mind (see Book 4). Low temperatures (< -25°C) are a particular issue in relation to weakening and problems with conductor installation, which can become very difficult.



### • Moisture

This is often described in terms of % relative humidity. But it is absolute humidity (actual quantity of water contained in the air and expressed in g/m<sup>3</sup>) that must be considered above all. Moisture is an important factor in ageing, which results primarily in an acceleration in the corrosion of prefabricated trunking and metal cable trays. The choice of material for these items is fundamental. Ventilation and drainage are equally critical to limit the effects of corrosion.

### • Presence of water

Although moisture is characterised by the presence of water in the form of steam, water in liquid form can also be a factor in the deterioration of power ducts. As a general rule, the presence of water does not cause problems in protected power equipment rooms but it can become a problem in terminal distribution (according to the site) and obviously also in exterior ducts. Two options are therefore possible: using a weatherproof cable tray or busbar system, or using a non-weatherproof cable tray. In the latter case, it is the resistance of the cables that determines water resistance. This is often the choice for exterior installations. Consideration must then be given to encouraging water to drain and flow away from the cable bundles. Wire cable trays are particularly suitable in this respect.

## > Additional stresses

### • Presence of corrosive and polluting substances

The stresses shown here are linked to the environment and local climatic conditions. They can be aggravated by chemical stresses connected with the activity and constitute one of the major causes of ageing. The product choices made (see page 30) are therefore critical.

- Industrial atmospheres carry pollutants (SO<sub>2</sub>, H<sub>2</sub>S, HCl...) that not only cause significant corrosion but also hydrolysis or attack the pigments of certain synthetic materials.

- Urban and peri-urban atmospheres have ozone levels ( $O_3$ ) that accelerate ageing and nitrogen oxides ( $NO_x$ ) precursors of acidity.
- Maritime atmospheres are characterised by considerable humidity and by the presence of salts (chlorides) that corrode all metals. The presence of chemical agents can also add to the local conditions. They can be classified into five broad categories whose effects are well known.
  - Acids can be present in the form of vapours or splashing. They are organic (sweat, urine, etc.) or industrial (chemical, metal treatment, etc.) in origin. Their action is destructive to many metals, in particular to galvanised surfaces. Stainless steel generally behaves very well with acids, as do synthetic products, particularly those with a PVC base.
  - The bases can be in gaseous form (ammonia) or liquid form (detergents, caustic soda, bleach) in certain operations (agri-food, metal treatment, water treatment, etc.). Their effect on the majority of ferrous metals is limited but they can damage cuprous metals, as well as rubbers or some plastics (polycarbonate).
  - Oils can be splashed onto conductors in numerous sectors (workshops, cutting, machining) but also onto machines (cranes, transporters, wind turbines, etc.). Oils are a base on which dust sticks. In addition, they can damage many insulators (polycarbonate, PVC, polyester, etc.). It is therefore sensible to choose cables and conductors that are known to be resistant.
  - Solvents, in liquid or vapour form, are present in the pharmaceutical industry, in the manufacture of paints and varnishes, even in cleaning agents. It is also advisable to check how resistant the cables and all the plastic based products are to the type of solvent (chlorinated, aliphatic, cetonic, aromatic, etc.).
  - Hydrocarbons, in particular petrol, fuel oil or equivalent are present in garages, tunnels, on work sites, in filling stations and refineries. As with solvents, they require a specific choice of cable insulation.

### • Presence of dust

Cable trays are not particularly sensitive to dust accumulation. Care must simply be taken to avoid accumulation and to provide weatherproof connection devices. The provision of covers on trays in sheet metal, as well as on those in wire, can prevent much of the dust that gets in by gravity and makes cleaning easier. For prefabricated busbar systems, the use of models with a minimum protection rating of IP5X is recommended.



### • Presence of flora and moulds

This risk is connected with certain sectors (agri-food, for example - see page 37) or with exposure (hot, damp climate). When choosing the materials for power ducts (busbar systems, cables and cable trays), the resistance of the material must be taken into consideration. Metals, particularly stainless steel, are especially suited. Synthetic materials, even those considered to be resistant, such as polyolefin (polyethylene, polypropylene), can eventually promote the development of surface flora and even feed it. The choice of materials must therefore always take into account the possibility of cleaning and disinfection.

### • Presence of fauna

Rodents and insects are a risk which must not be ignored. They can attack cable insulation and, in this case, closed cable trays or prefabricated busbar systems (IP at least equivalent to 3X) can provide protection that is theoretically sufficient, at least against rodents. But in practice, joints and other changes of direction create discontinuities and animal penetration cannot be prevented. In some extreme cases, in particular with termites, only conductors that are screened with a metal sleeve are an effective defence.

## > Special stresses

### • Solar radiation

The sun's ultraviolet rays contribute to the deterioration of organic parts, in particular paints, polymers and synthetic materials in general. Humidity and temperature are also factors in the process of photodegradation. It is essential to check the resistance of materials for any installation, especially exterior installations. PVC and network polymers are proven to provide excellent resistance in cable trays and cables. The use of cable tray covers gives a protective screen.

### • Fire or explosion risks

Cables, cable trays and busbar systems are excellent carriers for the spread of fire. Moreover, the large quantity of insulating materials used constitutes both a high fire load (because of the calorific potential of the materials) and a potential source of toxic fumes and corrosive waste: hydrochloric acid, hydrocyanic acid, halides, etc. The choice of the type of conductor and the precautions to be put in place are therefore critical in relation to this fire risk (see page 38 for further details). A great many establishments, particularly public buildings, onboard installations, tunnels and numerous industrial installations present a serious fire risk, that mean that specific regulations must be taken into account.

### • Electromagnetic or electrostatic fields

This subject groups together generically numerous phenomena with very diverse implications: ageing of materials, electromagnetic compatibility, risk of fire or explosion due to electrostatic discharges. Sectors with exposure to high frequency radiation (microwaves) are more and more common (telephony, telemetry). This directly affects the insulating properties of the materials. Knowledge of dielectric properties can prove to be vital in the choice of conductors and cables and of the insulating properties or otherwise of their supports. Electromagnetic interference runs along conductors but also along all the conducting parts, including cable trays and prefabricated busbar systems. In addition to their shielding capacity (for metal parts) which has an attenuating effect on electromagnetic fields, their electrical continuity is essential. It makes it possible to maintain a constant reference voltage for the exposed conductive parts along the entire length of a conductor duct. Finally, the accumulation of electrostatic charges, source of fire (silos) or electronic malfunctions (dielectric breakdown) is another aspect in controlling these electromagnetic phenomena.

# Choosing power transport systems (continued)

## 2 CHARACTERISTICS OF PRODUCTS IN LIGHT OF EXTERNAL STRESSES

While habits largely contribute to the choice of solutions from the point of view both of the power to be transported and of the installation configuration (see diagram on page 4), the third key aspect is more complicated. Accounting for external stresses actually involves the usage location with regard to the performance of the products which are likely to meet the stresses that are actually present.

An overview of the main types of power transport products is provided below along with their features, before each of these stresses is addressed in detail with its technical and normative aspects.

### > Non-perforated sheet metal cable tray

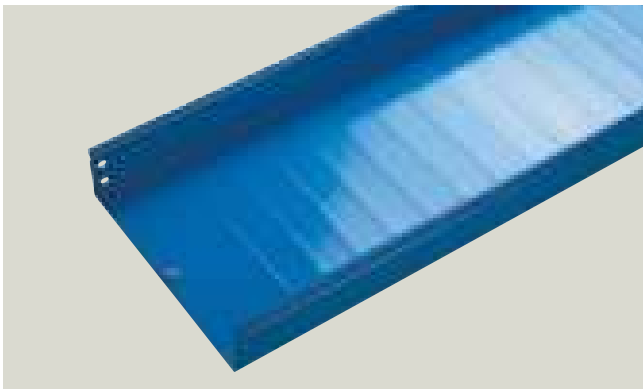

The basic product par excellence, simple, sturdy and universal. On the other hand, it does not permit effective ventilation for cables and does not provide the means to fasten them. The product offering is often a limited one and does not include any technical versions (stainless steel for example).

Rigidity improves when used with a cover. Protection is generally provided against falling drops of water and dust. In terms of fire resistance, it may offer the benefit of confinement but at the same time can also channel smoke in a vertical direction. Implementation must therefore be carefully considered in the light of this aspect.

### > Perforated sheet metal cable tray

As strong as the non-perforated model but lighter in weight, it allows cables to be fastened easily using cable ties. The perforations contribute to the ventilation and prevent water stagnation.

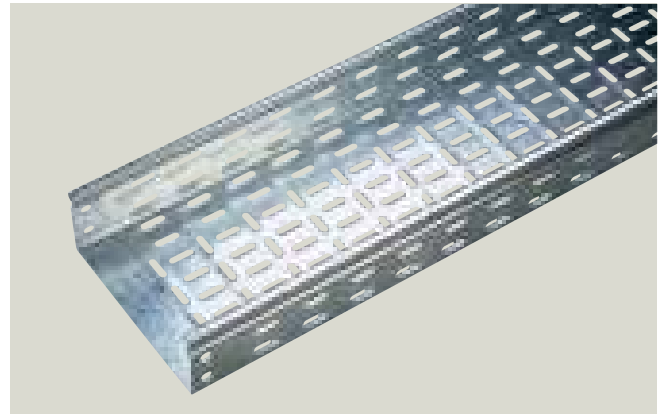

The benefits of having a cover are the same as those above: increased rigidity and protection from water drops and dust.

The covers also provide protection against impacts and falling objects (tools for example) for cable trays which are located under walkways or maintenance areas.

### > Wire cable tray

This routing method does not strictly speaking provide additional protection against external influences. It is the features of the cables which determine the IP protection class. The same is also true in relation to

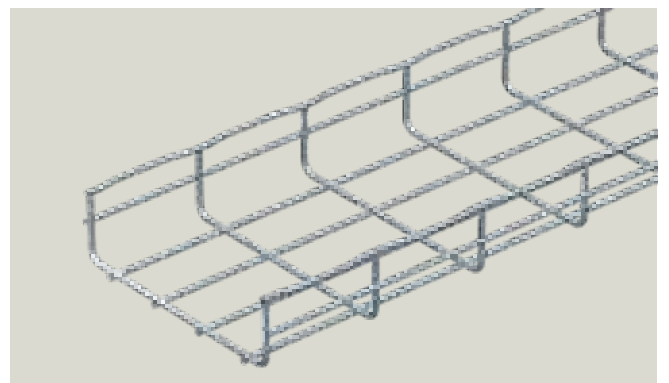

fire resistance or electromagnetic shielding. In return for these limitations, the wire cable tray is lightweight and can be implemented easily and rapidly, providing excellent mechanical support. Its increased elasticity allows it to be used in unstable environments or those subject to vibrations, particularly as the individual fastening of the cables is very simple.

Although it may be fitted with a cover, this is only useful for straight lengths or in areas which need to be protected from falling objects. The cover is not suitable for complicated routing which is precisely the special feature of the wire tray.

#### > Cable ladder



This is the "heavyweight" version of the wire cable tray. The ladder constitutes a support which is suitable for power cables and bundles of a greater weight or size. Its rigidity makes it most suitable for simple (backbone) routes. It is used as a distribution support for all types of cables in protected premises (e.g. technical areas, tunnels). Yet here again, it is the properties of the conductors and cables which determine the resistance to external influences.

#### > Cable trays made of thermoset materials (composite, polyester, etc.)

This type of routing is suitable for the harshest environments. It combines a number of qualities: resistance to high temperatures, excellent ageing, fire resistance (without halogen), no corrosion and very significant mechanical properties (IK 10 rigidity and impacts). It is also insulating (no earthing required), lighter than metal of the same dimensions and is easy to work with suitable tools. These assets are what make this type of product suitable for technical applications, which also explains its higher cost.



#### > Cable trays made of thermoplastic materials (PVC, PP)

Light to install and easy to cut and to work with, the cable tray made of thermoplastic materials is naturally insulating and does not require earthing. It is resistant to corrosion and moisture and can be classified for foodstuffs. Its limitations relate to resistance to fire, to maximum temperatures and even to cold impacts and UV radiation for the versions that are not intended for outside use.

# Choosing power transport systems (continued)

## > Terminal distribution trunking



Its appearance and performance features vary according to its intended use. Although there are models made of metal, the vast majority of terminal distribution trunking units, presented in the form of skirting trunking, columns or mini trunking, are made of extruded PVC. The protection class is limited to IP 40 or 41 and impact resistance to IK 07.

## > Prefabricated busbar systems

These devices combine the conductors and their enclosure in one product. They are able to achieve different levels of protection (IP 30/31 to IP54/55 or



even higher) and the vast majority are intended for internal use. The galvanised steel enclosure features high corrosion resistance.

## 2.1 The level of protection against external influences

As already stated, there are two ways of approaching the protection for the routing of conductors:

- the first consists in not taking account of the protection provided by the cable tray and in selecting conductors that are capable of directly resisting the stresses present, particularly in relation to the presence of dust (1<sup>st</sup> digit in the IP code), the presence of water (2<sup>nd</sup> digit in the IP code) and even in relation to the risk of mechanical impacts (IK code)

- the second consists in using routing for conductors which provides additional protection against one or other or indeed all of the stresses outlined above. In certain cases only the second option is possible where the conductors do not present an adequate level of resistance.

Industrial cables (type U1000 R2V for example) do not require any additional protection in the majority of installations; the routing is only used in these as a support: a wire cable tray which does not provide any additional protection is perfectly suitable.

By contrast the insulated conductors for terminal distribution (H07V-U/R for example) which have limited mechanical resistance must have their routing protected. This is the part played by cable trunking, among others.



**There are multiple types of conductors for all uses and all environments. Apart from the fire and EMC aspects inherent to the application, one question needs to be asked every time: what additional IP and IK protection needs to be provided to the conductors and cables via their cable routing? And if this is necessary, what is the level required?**

For outside installations, the stress of exposure to UV rays is an essential factor to be considered in synergy with the other climatic influences of temperature and moisture. Where the cables are not resistant to UV rays, the routings chosen must be completely closed or with little perforation and with a cover so that they are protected against light. Care must be taken with the discontinuities in protection which may exist in the crossbeams and changes in levels and in direction, they are all the more critical given the fact that the cables there are subject to voltages and curves which weaken the sleeves under the effect of the UV rays.



**Wire cable trays used outside in this oil installation supporting cables chosen for their suitability for outside conditions**



**The prefabricated trunking provides a different response to the requirements in the sense that it includes conductors (busbars) and their insulation (supports) which are protected from external influences by a solid enclosure that defines the protection class.**

The tables in the following pages are a reminder of the protection levels that are specific to conductors as well as the additional protection levels provided by the routing system.

# Choosing power transport systems (continued)

Protection features of the conductors and cables																
Types of stress (see page 16)		Level	Code IEC 60364-1	U-1000R2V U-1000AR2V	U-1000RVFV U-1000ARFV	U-1000R6PFV	H07 RN-F A07 RN-F	H1 XDV-AR H1 XDV-AS	H07 V-UJ V-R	H07 V-K	FR-N 05 VV-U FR_N 05 VV-R	H05 VV-F	H03 VVH2-F H05 VVH2-F H05 RR-F	H05 RR-F A05 RR-F	Cables CR1 <sup>(2)</sup>	
Mechanical stresses	Transfers or movements	1	CB1	•	•	•	•	•	•	•	•	•	•	•	•	
		2	CB3	•			•				•		•	•	•	(•)
		3	CB4				•									
	Mechanical impacts	1	AG1	•	•	•	•	•	•	•	•	•	•	•	•	•
		2	AG2	•	•	•	•	•	•	•	•	•	•	•	•	•
		3	AG3	•	•	•	•	•	•	•	•	•	•	•	•	•
			AG4		•	•	•	•	•	•	•	•	•	•	•	•
	Mechanical vibrations and impacts	1	AH1	•	•	•	•	•	•	•	•	•	•	•	•	•
		2	AH2	•	•	•	•	•	•	•	•	•	•	•	•	•
		3	AH3				•								•	•
	Seismic effects	2	AP1/AP2	•	•	•	•	•	•	•	•	•	•	•	•	•
		2	AP3	•	•	•	•	•	•	•	•	•	•	•	•	•
3		AP4		•	•	•	•	•	•	•	•	•	•	•	•	
Climatic stresses	Temperature	1	AA4/AA5	•	•	•	•	•	•	•	•	•	•	•	•	
		2	AA3 to AA5	•	•	•	•	•	•	•	•	•	•	•	•	
		3	AA3 to AA8	•	•	•	•	•	•	•	•	•	•	•	•	(•)
	Moisture	1	AB4/AB5	•	•	•	•	•	•	•	•	•	•	•	•	
		2	AB6/AB7	•	•	•	•	•	•	•	•	•	•	•	•	
		3	AB8 <sup>(1)</sup>	•	•	•	•	•	•	•	•	•	•	•	•	(•)
	Presence of water	1	AD1	•	•	•	•	•	•	•	•	•	•	•	•	
		2	AD2 to AD3	•	•	•	•	•	•	•	•	•	•	•	•	
		3	AD4 to AD7	•	•	•	•	•	•	•	•	•	•	•	•	(•)
Additional stresses	Presence of corrosive and polluting substances	1	AF1	•	•	•	•	•	•	•	•	•	•	•	•	
		2	AF2/AF3	•	•	•	•	•	•	•	•	•	•	•	•	
		3	AF4				•							•		
	Presence of dust	1	AE1 to AE3	•	•	•	•	•	•	•	•	•	•	•	•	
		2	AE4	•	•	•	•	•	•	•	•	•	•	•	•	
		3	AE5/AE6	•	•	•	•	•	•	•	•	•	•	•	•	
	Presence of flora and moulds	1	AK1	•	•		•	•	•	•	•	•	•	•	•	
		2	AK1+		•	•		•	•	•	•	•	•	•	•	
		3	AK2		•	•		•	•	•	•	•	•	•	•	(•)
	Presence of fauna	1	AL1	•	•	•	•	•	•	•	•	•	•	•	•	
		2	AL1+		•	•		•	•	•	•	•	•	•	•	
		3	AL2		•	•		•	•	•	•	•	•	•	•	
Special stresses	Solar radiation	1	AN1	•	•	•	•	•	•	•	•	•	•	•	•	
		2	AN2	•	•	•	•	•	•	•	•	•	•	•	•	
		3	AN3	•	•	•	•	•	•	•	•	•	•	•	•	
	Fire or explosion risks	1	BE1	•	•	•	•	•	•	•	•	•	•	•	•	
		2	BE2 / CB2	•	•	•	•	•	•	•	•	•	•	•	•	(•)
		3	BE3	•	•	•	•	•	•	•	•	•	•	•	•	
	Electromagnetic radiation	1	AM 1	•	•	•	•	•	•	•	•	•	•	•	•	
		2	AM2/AM3	•	•	•	•	•	•	•	•	•	•	•	•	
		3	AM4		•	•		•						•	•	

(1) This classification includes any possible temporary immersion (IP x7) but not permanent submersion which requires special conductors (U-1000 R6PFV for example)

(2) Generic values for informational purposes for fire-resistant cables (types U500 X, 1000 X or XV) You must refer (•) to the manufacturer information for more details on the exact features.

### Supplementary protection level provided by routing of conductors

Types of stress (see page 16)		Level	Code IEC 60364-1	Non-perforated sheet metal cable trays	Non-perforated sheet metal cable trays with a cover	Perforated sheet metal cable trays	Perforated sheet metal cable trays with a cover	Wire cable trays	Wire cable trays with a cover	Cable ladders	Closed cable trays made of thermoset materials	Closed cable trays made of thermoplastic	Metal terminal distribution trunking	Thermoplastic terminal distribution trunking	
Mechanical stresses	Transfers or movements <sup>(1)</sup>	1	CB1	•	•	•	•	•	•	•	•	•	•	•	
		2	CB3	•	•	•	•	•	•	•	•	•	•	•	
		3	CB4		•		•		•			•		•	
	Mechanical impacts	1	AG1	•	•	•	•					•	•		•
		2	AG2	•	•	•	•					•	•	•	
		3	AG3		•		•					•	•		
				AG4		•		•				•	•		
	Mechanical vibrations and impacts	1	AH1	•	•	•	•		•	•	•	•	•	•	•
		2	AH2	•	•	•	•		•	•	•	•	•	•	•
		3	AH3	•	•	•	•		•	•	•	•	•	•	•
	Seismic effects	2	AP1/AP2	•	•	•	•		•	•	•	•	•	•	•
		2	AP3	•	•	•	•		•	•	•	•	•	•	•
3		AP4		•		•		•	•	•	•	•	•	•	
Climatic stresses	Temperature	1	AA4/AA5	•	•	•	•	•	•	•	•	•	•	•	
		2	AA3 to AA5	•	•	•	•	•	•	•	•	•	•	•	
		3	AA3 to AA8	•	•	•	•	•	•	•	•	•	•	•	
	Moisture <sup>(2)</sup>	1	AB4/AB5	•	•	•	•	•	•	•	•	•	•	•	•
		2	AB6/AB7	•	•	•	•	•	•	•	•	•	•	•	•
		3	AB8	•	•	•	•	•	•	•	•	•	•	•	•
	Presence of water	1	AD1	•	•	•	•	•	•	•	•	•	•	•	•
		2	AD2 to AD3		•		•		•			•	•	•	•
		3	AD4 to AD7											•	•
Additional stresses	Presence of corrosive and polluting substances <sup>(2)</sup>	1	AF1	•	•	•	•	•	•	•	•	•	•	•	
		2	AF2/AF3	•	•	•	•	•	•	•	•	•	•	•	•
		3	AF4	•	•	•	•	•	•	•	•	•	•	•	•
	Presence of dust	1	AE1 to AE3	•	•	•	•	•	•	•	•	•	•	•	•
		2	AE4		•		•		•			•	•	•	•
		3	AE5/AE6		•		•		•			•	•	•	•
	Presence of flora and moulds <sup>(2)</sup>	1	AK1		•		•		•			•	•	•	•
		2	AK1 +		•		•		•			•	•	•	•
		3	AK2		•		•		•			•	•	•	•
	Presence of fauna	1	AL1	•	•	•	•	•	•	•	•	•	•	•	•
		2	AL1+		•		•		•			•	•	•	•
		3	AL2		•		•		•			•	•	•	•
Special stresses	Solar radiation	1	AN1	•	•	•	•	•	•	•	•	•	•	•	
		2	AN2		•		•		•			•	•	•	
		3	AN3				•		•			•	•	•	
	Fire or explosion risks	1	BE1	•	•	•	•	•	•	•	•	•	•	•	•
		2	BE2 / CB2	•	•	•	•	•	•	•	•	•	•	•	•
		3	BE3		•		•		•			•	•	•	•
	Electromagnetic radiation	1	AM 1	•	•	•	•	•	•	•	•	•	•	•	•
		2	AM2/AM3	•	•	•	•	•	•	•	•	•	•	•	•
		3	AM4		•		•		•			•	•	•	•

(1) This characteristic depends for a large part on the implementation: number and type of supports

(2) The nature of the constituent materials (see next chapter 2.2) determines the moisture, corrosion and flora resistance

# Choosing power transport systems (continued)

## 2.2 Protection against corrosion

Metallic routing for conductors is exposed to the stresses of atmospheric corrosion and, depending on where it is used, to the specific stresses associated with the activity sector where the routing is installed. Among other external stresses, the table on pages 14-15 summarises the corrosion conditions specific to numerous premises and sites with a generic classification at three levels (low, medium, high) which are covered in the form of typical solutions in the tables on pages 16 to 19.



< Using a product which is unsuitable for the environment may have serious consequences

Although identical or similar materials and treatments can be found all over the world for the large number of metallic routing ranges for Legrand products, the names and rules for identification may differ.



^ The technical solutions used can be marked in accordance with the products, as in the example of the routings using Cablofil® wire and involving mnemonic methods that can be found in the various documents, catalogues and technical guides.

The main technical solutions used are described below.

### > Pre-treatments

- **PG** and **GS** pre-treatments consist of a protection deposited using a continuous hot-dip process in accordance with the standards EN 10244-2 (wires) or EN 10326 and EN 10327 (sheet metals and strips). Coatings are generally zinc-based (Z) but they can also be zinc alloy-based with iron (ZF), or aluminium alloy with zinc (AZ) or with silicon (AS). In this process the edges and cut-outs are not protected following manufacture; protection is therefore limited and is more suitable for environments that are only slightly harsh (see table on page 36)
- **EZ** consists of a zinc coating deposited in a continuous electrolytic process in accordance with the standards EN 12329 (wires) and EN 10153 (sheet metals and strips). The deposit principle itself limits the possible thicknesses (< 10 µm). Resistance to corrosion is limited and is suitable for internal environments. It has a smooth appearance with a more or less bluish colour and more or less shiny look although this does not impact on the corrosion resistance. An electrostatic epoxy powder coating may be applied as a finish in all the RAL colours. Besides exhibiting excellent corrosion resistance qualities, it also allows circuits to be identified or adjustments to be made for special aesthetic requirements.



The processes designated **PG**, **GS** and **EZ** are often used in a complementary manner in the same routing system depending on the type and the geometry of the parts. This same principle of adapting the process or the material to the part to be implemented, cable tray or accessory can also be found for post-coated and stainless steels.

### > Post-treatments

In these processes the protection treatment is deposited after the cable trays or accessories are manufactured and formed. The cut-out edges, holes and welds are therefore protected with the same level of performance. Considerable thicknesses may be deposited enabling use in harsh internal or everyday external conditions.

- **[GC]** consists of a hot-dip galvanisation treatment in a molten zinc bath in accordance with the standard ISO 1461. The usual thicknesses deposited are between 45 and 55 µm and may reach 80 µm upon request. It should also be noted that Legrand galvanised products comply with the RoHS Directive and are therefore lead-free.

The appearance of the galvanised surfaces can vary widely with more or less marked spangling and whitish traces which have no impact. The essential resistance characteristic is provided through the thickness. Any use of galvanised cable trays in environments that are too acidic and which encourage dissolution of the zinc should be avoided. In such cases, stainless steel is more suitable.

- **[DC]** consists of a treatment known as lamellar zinc treatment where the parts undergo hot-dip treatment. Lamellar zinc (flZn) is known under various commercial names which have passed into everyday language. The particles with varying proportions of zinc, aluminium and other loads are dispersed within an organic matrix: the process is known as organometallic coating according to the standard ISO 10383. The resulting corrosion resistance is excellent, exceeding 1000 hours of salt spray according to the standard ISO 9227.

This post-treatment process is not suitable for large-sized parts such as cable trays but is more suited to accessories. As such the two **[GC]** and **[DC]** systems are perfectly consistent and complementary. They cover a very wide range of applications (see table on page 36)

### > Stainless steels

Cable trays made from these steels are the most successful option and provide the highest performance in terms of corrosion resistance. They can be used in the harshest of environments and meet the requirements related to compatibility and safety in the food-processing industry.

Nevertheless, caution is required as a number of products on the market may be made of less precious and lower-performance types of steel; the essential pickling and passivation processes are not always carried out and the accessories may be of inferior quality.

Austenitic steels provide a benchmark in the area of corrosion resistance with types 304 and 316 being well-known in this regard. However, caution

is required with these designations, which cover compositions which may vary and above all do not guarantee the low carbon content of these steels (letter L in the American AISI designations). This, however, is the condition of their resistance to intergranular corrosion may become evident in the welds, bends and other persistent stress areas. For this reason, the use of designations (from the German Werkstoffnummer) in accordance with the standard EN ISO 10088-2 is preferred and is unambiguous.

- **[1.4307]** which can also be referred to as **[304L]** or **[X2CrNi18-9]** is a stainless steel with a very wide range of uses in natural and corrosive environments. Its resistance is limited where it is exposed to halides (derived from chlorine or fluorine) and where there are large quantities of chlorides (sea spray). In such cases, steel **[1.4404]** is preferable.

- **[1.4404]** also known as **[316L]** or **[X2CrNiMo17-12-2]**. This molybdenum alloy steel makes up for the deficiencies in **[1.4307]** steel. It features excellent properties in a very wide range of environments, although like all stainless steels it remains sensitive to chlorinated environments.



# Choosing power transport systems (continued)

## > Pickling and passivation

Corrosion resistance in stainless steel is due to a layer of oxides rich in chrome which is formed naturally when it is exposed to a normal environment that is capable of providing enough oxygen. This is why according to the standard ISO 10088-1, a steel must contain at least 10.5% chrome in order to be called stainless. Contact with air or with aerated water creates and maintains the corrosion resistance of the passive surface which is restored automatically, including where the metal is harmed, scratched or cut. This is the so-called passive or "passivated" state: the steel protects itself.

However, under certain conditions this passive state is destroyed and it cannot be restored via natural means. These conditions can be seen in particular on surfaces which have been deprived of oxygen, such as mechanical joints, closed angles or on areas such as welds where there has been a change to the metallurgical composition.

The corrosion resistance can therefore be damaged, resulting in localised forms known as pitting or crevice corrosion.

In order to limit the risks associated with these types of discontinuity in the protection, it is absolutely essential that the products manufactured from stainless steel undergo a descaling and pickling treatment following by passivation.

Descaling consists of mechanically removing the thick layer of oxides visible on the surface of the welds.

Pickling consists of removing a fine layer aimed mainly at restoring a consistent appearance and at (re) creating the passivated state of the surface.

Mixtures of nitric and hydrofluoric acid are generally used for these operations.



## > Precautions when implementing stainless steel routing

Stainless steels may become sensitive locally to corrosion following assembly, drilling or welding operations. Restoration of the passive layer may be limited to one-off pickling (pickling paste + rinsing, brushing and cleaning) or may require more intensive methods if there is a large number of parts or if these cover a large area.

However, the major risk associated with using stainless steels relates in particular to pollution by iron particles provided by machining operations (tools also being used for the steel, metallic brushes, etc.) or even by neighbouring operations (milling for example). The area is then polluted with iron particles which will oxidise and damage the appearance considerably. Removing these particles is difficult in practice and requires chemical treatment. Therefore, taking all precautions to prevent these from occurring is preferred by protecting the parts up to the time of delivery (with film, tarpaulin, etc.).



**Legrand sheet metal or wire cable trays are manufactured solely with the finest grades of stainless steel and they systematically undergo pickling and passivation treatments which guarantee the highest level of resistance to corrosion and the absence of iron pollution.**

In the event of pollution only a decontamination treatment followed by passivation will be able to eliminate these particles and prevent the subsequent formation of spots or even larger corrosion stains. Moreover the parts will have to be cleaned before this remediation treatment if they are contaminated with grease or oil.

(See Book 8 for more detailed information)



**Traces of corrosion on the stainless steel consoles caused by discharges of iron particles due to grinding or machining assumed to be nearby. A risk that may have unacceptable aesthetic consequences...**

### > Precautions when implementing zinc-plated and galvanised steel routing

It is considered that when cutting out sheet metal or wire cable trays in **PG**, **GS** or **EZ**, zinc-plated steel, the protection against corrosion is not affected if the cutting methods used are mechanical (sheet metal cutter, bolt cutter, drill bit, etc.). The exposed part of the material is protected as a result of closeness to zinc. This is particularly the case as these products are aimed at environments with limited harshness (See table on page 35).



**Caution, cutting by grinding or chopping may lead to local melting of the zinc and to loss in protection over larger areas. The same occurs with welding operations which are sometimes carried out for fixing consoles or other accessories. All these types of work call the performance guarantee into question and require the protection to be restored. Vigorous brushing aimed at eliminating the non-adherent scaling, followed by degreasing and spraying with an aerosol which is rich in zinc (cold zinc) may provide a satisfactory solution.**

The causes of damage to the zinc layer of the **GC** galvanised-steel routing are identical to those described above (milling, welding, etc.) but may be more critical where these products happen to be used in harsher environments.

Clean cuts may be considered to remain adequately protected by galvanic effect, with the rust remaining limited to a brown line on the substantial thickness of the material. However, there is good reason to be very cautious about any operation which causes greater damage to the protection. The following are possible depending on the resistance sought:

- brushing of the surface and applying several layers of paint which is rich in zinc until an adequate thickness is obtained (approximately 100 µm)
- brushing of the surface, heating with a torch and applying an alloy strip until the desired thickness is obtained
- preparing the damaged surface by shot blasting (level Dsa 3 in accordance with ISO 8501-1). and completing metallisation of the zinc in accordance with EN 22063/ISO 2063 (projection of molten zinc or "metallisation"). It should be noted that this last operation alone can guarantee restoration of the initial protection level.

# Choosing power transport systems (continued)

## > Precautions for avoiding galvanic couples due to contact with different types of metals

Whatever their type, the Legrand Group cable routing ranges and their fixing accessories have been designed to provide consistent resistance to corrosion and to prevent the formation of galvanic couples which are unfavourable between metals.

If this precaution is not taken during the installation by juxtaposition of incompatible metals or by using

accessories with inadequate protection (standard quality zinc-plated screws), there is a high risk of the resistance to corrosion being reduced, or even of corrosion being caused to the fastening or assembly areas. The table below provides some indications of the choices available for the parts used for fixing, for the fittings and generally for the elements that come into contact with the routing for the conductors.

Type of parts for assembly or for fixing, screws	Type of routing to be assembled or fixed				
	Zinc-plated steel	Galvanised steel	Stainless steel type 1.4307	Stainless steel type 1.4404	Aluminium and alloys
Zinc-plated steel	✓	✓	✗	✗	✗
Galvanised steel <sup>1</sup>	✓	✓	✗	✗	✗
Nickel-plated brass	✓	✓	✓	✓	✗
Tinned brass	✓	✓	✗	✗	✓
Stainless steel type 1.4307	✗	✗	✓	✓	✓
Stainless steel type 1.4404	✗	✗	✓	✓	✓
Aluminium	✗	✗	✗	✗	✓

1: including the protection by lamellar zinc treatment

✓ : recommended

✓ : possible

✗ : not recommended



Legrand sheet metal or wire cable tray products along with those made of synthetic materials really do meet all needs by providing suitable resistance.

However, without making things too complicated, having a good knowledge of the different solutions is useful in order to make the right choice, the only guarantee for the durability of installations. Simple visualisation of the product does not always allow a purchaser to differentiate easily between the materials (stainless steels for example) or the actual

thicknesses applied for treatment. Likewise the consistency of accessories and routings is often forgotten with the result that the performance is not homogeneous.

Cable trays	Accessories
EZ/PG/GS	EZ/GS
GC	GC/DC
1.4307	1.4307
1.4404	1.4404



Standard IEC 61537 defines the following corrosion-resistance classes by specifying typical solutions and a corresponding period of resistance to salt spray tests. This categorisation is not necessarily easy to use and it does not cover all the possible technical solutions. Similarly, the value for the salt spray test (in hours) must be taken with caution.

The Legrand approach developed over the previous pages based on pre-treated products (categories 1 to 4), post-treated products (categories 5 to 8) and stainless steel products (category 9) covers all the cases applicable to this IEC standard.

Class	Salt spray test period (hrs)	Reference or finishing materials
1	24	Electroplated to a minimum thickness of 5 µm
2	96	Electroplated to a minimum thickness of 12 µm
3	155	Pre-galvanised to grade 275 according to EN 10326 and EN 10327
4	195	Pre-galvanised to grade 350 according to EN 10326 and EN 10327
5	450	Post-galvanised to a zinc mean coating thickness (minimum) of 45 µm according to ISO 1461 for zinc thickness only
6	550	Post-galvanised to a zinc mean coating thickness (minimum) of 55 µm according to ISO 1461 for zinc thickness only
7	700	Post-galvanised to a zinc mean coating thickness (minimum) of 70 µm according to ISO 1461 for zinc thickness only
8	850	Post-galvanised to a zinc mean coating thickness (minimum) of 85 µm according to ISO 1461 for zinc thickness only (usually high silicon steel)
9A	850	Stainless steel manufactured to ASTM: A 240/A 240M – 95a designation S30400 or EN 10088 grade 1-4301 without a post-treatment
9B	850	Stainless steel manufactured to ASTM: A 240/A 240M – 95a designation S30400 or EN 10088 grade 1-4301 with a post-treatment
9C	850	Stainless steel manufactured to ASTM: A 240/A 240M – 95a designation S31603 or EN 10088 grade 1-4404 without a post-treatment
9D	850	Stainless steel manufactured to ASTM: A 240/A 240M – 95a designation S31603 or EN 10088 grade 1-4404 with a post-treatment

# Choosing power transport systems (continued)

Selection of anti-corrosion protection depending on environment												
Designated conditions for moisture and harshness of the environment	Exposure type	ISO 12944-2 corrosivity class	Type of premises, site or usage	Cable tray	EZ	PG	GS	Epoxy	Epoxy	GC	1.4307	1.4404
				Accessories	EZ	GS	EZ	GS	GC	DC	GC	DC
Dry and non-corrosive	Internal	C1	Domestic, dwellings, residential, offices									
Momentarily moist and slightly corrosive	Internal	C2	Assembly workshops, retail shops, warehouses, theatres, restaurants, common rooms, dance halls, hospitals									
May be moist and/or corrosive	Internal	C2	Manufacturing or machining workshops, kitchens, shared bathrooms, cellars, etc.									
Moist and moderately corrosive	Internal	C3	Food-processing industry, animal husbandry buildings, abattoirs, covered sales halls, auction halls									
	External		Rural exterior moist and slightly harsh									
Moist and corrosive Mixture of urban/rural/light industrial	Internal	C3	Harsh and corrosive processes (surface treatments, foundries, ship engine rooms)									
	External		Everyday external mixture of urban/rural									
Moist and corrosive Heavy industrial	Internal	C4	Acid or solvent-type harsh processes									
	External		External heavy industrial and/or very moist, e.g. tropical									
Very moist and highly corrosive, e.g. seaside	Internal	C5M	Very harsh halogenous or chlorinated processes									
	External		External at sea, by the seaside and coast subject to spray									
Very moist and extremely corrosive Petrochemical industry	Internal	C5I	Very harsh industrial processes (petrochemical industry)									
	External		External, out at sea, offshore									

- Normally suitable for the corrosive category
- Under additional conditions for protection against direct precipitations or sprays through canopy or covered shelter
- Subject to the presence of high concentrations of aggressive agents: salt, chlorine, wine, mustard in the food-processing industry, chlorinated solvents, fluorides, ketones with high level of concentration in the chemical industry
- Not suitable for the corrosive class



## Compatibility and safety for the food processing industry

There are no special rules associated with conductor routing in the food processing industry. However, as with all fittings, devices and machines in these types of premises, a rational design must identify, evaluate and overcome the significant risks in terms of food safety. This is the HACCP (Hazard Analysis Critical Control Point) Quality system.

In Europe there are regulations governing the different aspects which are specific to the safety of foodstuffs (Directive 852/2004/EC) and the materials and items destined to come into contact with these foodstuffs (Directive 1935/2004/EC).

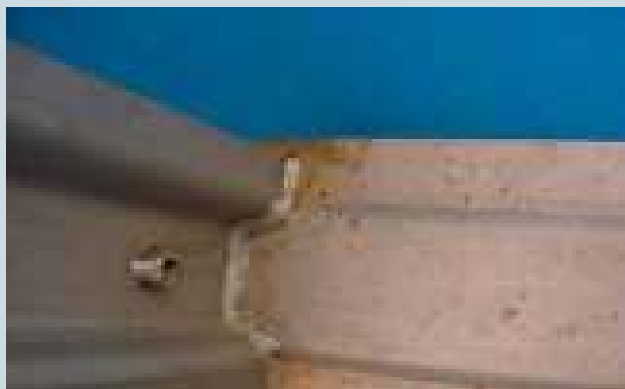

A crucial distinction must be made between the problem of materials and the contact these have with food and the problem of hygiene and cleaning of devices and installations. Cable trays are not usually destined to come into contact with foodstuffs, and where this does occur by accident, the foodstuffs affected are not reintegrated into the manufacturing process. On the other hand, the two criteria of cleanability and resistance to cleaning agents are very important in relation to hygiene. The French standard XP U 60-010 sets out a certain number of design rules in relation to the suitability of machinery and equipment for cleaning. Refer to Book 8 where necessary for resistance of materials to chemical agents and to the various cleaning products.

The open and ventilated structure of Cablofil® and the design of its secure T-welded edge minimise the areas which retain different types of dust and pollutants. It is suitable for the requirements when routing cables in clean rooms (ultra-clean rooms) in accordance with EN ISO 14644.

Wire cable trays can be blown out or vacuumed or even washed; the draining and drying processes are simple and natural.

This same feature is also noticeable with outside installations which are subject to rainfall. Stainless steel cable trays 1.4307 (304L) and 1.4404 (316L) are designed to meet the requirements for compatibility with foodstuffs and chemical resistance in the food processing industries.



A minimum distance of 100 mm is recommended between the cable trays and the surrounding partitions, walls or ceilings, allowing cleaning devices to pass through easily (source: Nestlé good Hygiene Engineering). Cleaning of cable trays is made easier by installation on consoles in brackets or on hanging fittings. It is more difficult in a sling or when suspended (see fastening methods on page 39).

# Further precautions and constraints

In addition to selecting the correct type of duct and choosing the correct type of materials from which it is composed, a number of further constraints must be taken into consideration in order to ensure compliance with all service and safety requirements ducts.

## FIRE BEHAVIOUR AND CONSTRUCTION SAFETY PRECAUTIONS

Although the type of cable and conductor is the determining factor in the fire behaviour of ducts and conduits, the choice of cable tray type and the installation of the latter in line with installation precautions are just as crucial (see page 40). Cables are very rarely the source of a fire. This would only occur if the cable was overloaded to a point at which its insulation melts and inflames materials in the vicinity, or if it short-circuited due to mechanical damage. Cable ducting is therefore not a potential source of fire. However, cables may contribute to the spread of fire if appropriate construction precautions are not taken. Routing in rooms, ceilings or service ducting and feeding through partitions promotes air flow, potentially creating chimneys for gases and smoke and representing an energy source capable of causing arcs and secondary short circuits which can encourage the spread of fire. Therefore, at this stage of a fire they constitute a fairly significant thermal load.

### 1 ASSESSMENT OF THE FIRE RISK

The potential risk of fire damage to cable ducting and the potential consequences of a resulting spread of fire can only be assessed on a case by case basis. The tables on pages 14 and 18 offer a preliminary approach. Understanding the conditions of external influences in relation to materials handled or interposed (BE1 to BE4 according to IEC 60364-5-51, which defines among other things the fire risk), enables a suitable type of cable to be selected (see Book 4, table on page 62).

### 2 FIRE BEHAVIOUR OF CABLES AND CONDUCTORS

#### 2.1 Fire response

The classification of fire behaviour is based on a number of tests which are defined in accordance with international standards (IEC 60331 and IEC 60332), European standards (EN 50200) or national standards for certain types of cables (for example French standard NF C 32-070 for category C1).

There are 3 categories of "fire response" rating.

- C3: no special characteristic
- C2: flame-resistant. The majority of cables used in installations belong to this category.
- C1: flame retardant. The use of cables in this category limits the risk of the spread of fire in cable layers and trunking. FR-N1 X1... , FR-N05 G2 (U, R or K) and FR-N07 X3 (U, R or K) cables belong to this category.

In situations where the risk of the spread of fire is high (long vertical ducts) or when the safety of the installation is essential, C1 category cables must be used.



#### Fire behaviour of vertical cable layers

The fire resistance test for cables (category C1 fire retardant) in a layer is carried out according to IEC standard 60332-3 (EN 32072) in a 4m-high test cubicle in which the cables are mounted on a vertical ladder. Three categories, A, B and C, establish the severity rating according to the volume of organic insulating material involved: respectively 7 dm<sup>3</sup>, 3.5 dm<sup>3</sup> and 1.5 dm<sup>3</sup> per metre of the layer. The burner flame is applied to the lower part for 30 minutes, after which the burnt cables must not have reached a limit fixed at 0.4m from the top end of the layer.

## > Halogen-free cables

Most cables used today are insulated partially or wholly with polyvinyl chloride or PVC (U 1000 R2 V, H07 VVH2-F, H07 VU, etc.). These conductors are naturally flame-retardant due to the presence of chlorine and offer good levels of fire resistance. They are normally classified as C2 (flame-resistant) and contribute to the intrinsic safety of installations. The disadvantage of PVC: if conductors are caught in a fire, hydrogen chloride is emitted which as a gas is an irritant, but this does have the advantage that it allows detection of the outbreak of fire due to the pungent odour that is released. It should be noted that hydrogen chloride is not classified as toxic in the ISO 9122 report (first section); the major lethal risk relates to carbon monoxide. Nevertheless, it is often prohibited in enclosed and poorly ventilated spaces (basements, railway tunnels, etc.). The restriction is in fact largely due to the risk of corrosion from the hydrochloric acid released in the vapour of this gas which when it spreads can damage, sometimes with a delayed effect, sophisticated or expensive systems: complex optical devices, medical equipment, metrology and process control devices, very high-precision machinery, aeronautical equipment, etc. The areas must therefore be decontaminated as quickly as possible. It must be remembered that the requirement to protect these systems and to expel chlorine led to the development of C1 cables, known as halogen-free cables, with flame retardant composed of aluminium trihydrate or magnesium dihydrate. These cables emit little smoke and corrosive elements. These include types FR-N1X1X2, FR-N1X1G1, FR-N07X4X5-F and more generally all conductors compliant with French standard NF C 32-310.

## 2.2 Fire resistance

"Fire response" categories assess the flammability of cables but make no indication of their capacity to maintain supply to installations in the event of fire. In order for safety circuits to continue to function, cables certified for their "fire resistance" must be used.

There are two different categories of "fire resistance".

- CR2: no special characteristics

- CR1: fire resistant.

U500 X, U500 XV, 1000 X or 1000 XV conductors with "fire resistant" mineral insulation, "Lyonotox" and "Pyrolyon", and certain power and signalling cables belong to this category.

Although the type of cable and conductor is the determining factor in the fire behaviour of ducts and conduits, the choice of cable tray type and the method of its installation in compliance with installation precautions are just as crucial.

Fire resistance test device for cables in vertical layers

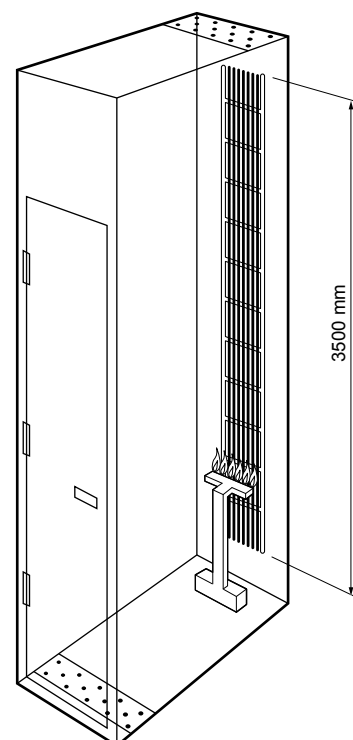

# Further precautions and constraints (continued)

## 3 INSTALLATION PRECAUTIONS

### 3.1 Routing and layout of cable layers

The layout of cable layers and groupings as well as individual cables themselves within these layers plays an important role in the development of a fire. Cables must be laid out in an orderly fashion, limiting gaps between them wherever possible in order to prevent a "kindling" effect which would intensify the fire.

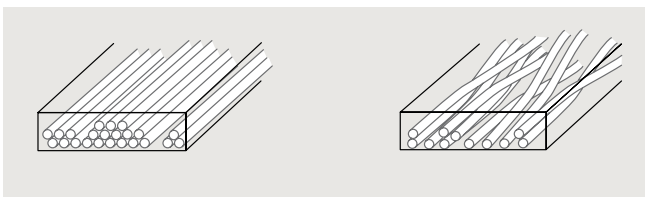

Dense, tight and compact layers are the least likely to catch fire, but in turn their capacity for heat dissipation is lower, which can lead to reduced current-carrying capacity.

Broadly speaking, layouts which create natural "chimneys" must be avoided: this principle applies not only to conductors themselves but also to cable layers and layers with elements in the surrounding environment (walls, ceilings etc).

### 3.2 The layout of vertical layers

Vertical layouts of layers create a chimney effect which is increased by proximity to a wall or a structure parallel to the layer. A distance  $d$  of at least half the width  $L$  of the layer must be maintained to reduce this effect, otherwise a perpendicular layout may be preferable.

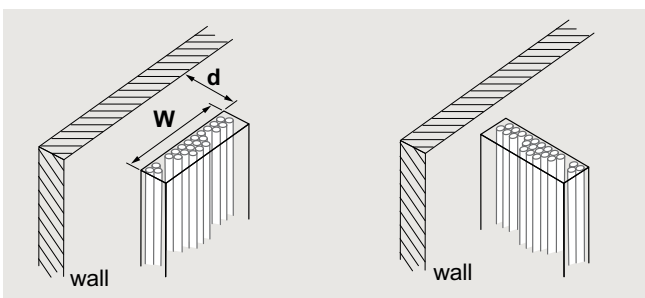

### 3.3 Layout of horizontal layers

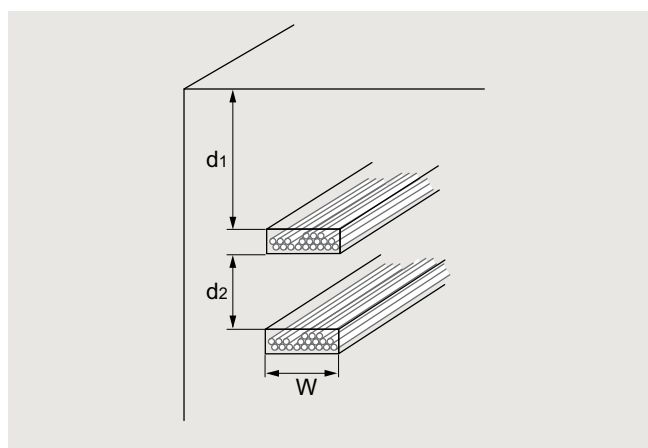

It is advisable to position layers beneath ceilings at a distance  $d_1 > 2 \times W$  (at least twice the width of the cable tray). In the event of fire, this will in part prevent a situation where the cables are positioned in the hottest of the gas layers. In order to prevent fire spreading from one layer to another, a minimum distance of  $d_2 > W$  is also advisable.

### 3.4 Specific layouts in the vicinity of ducts

Electrical ducts must not be exposed to the risk of harmful temperatures due to proximity to heat sources (air, water or smoke vents, etc). If adequate distances cannot be complied with, screens or thermal insulation must be placed between the gaps.

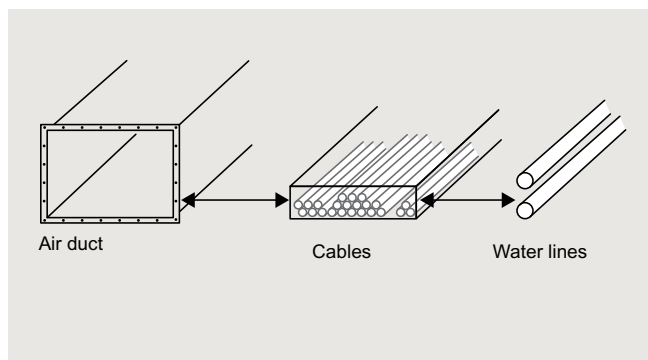

### 3.5 Cable entries into enclosures

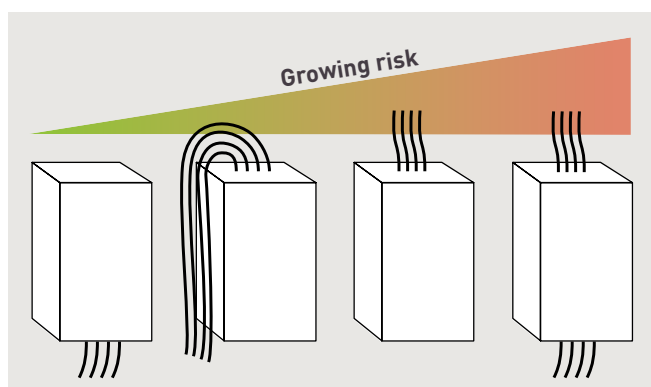

Layout of cable entries, from most suitable to least suitable

Leading cables into cabinets can create entries liable to spread fire into the cabinet (in the case of an external fire) or into the environment (in the case of an internal fire). In practice cable entries in the bottom part of the cabinets or enclosures should be preferred. Fire will be better contained within the enclosure and, in the case of an external fire, the area at ground level is typically less exposed to risk.

However, if cables do have to be led into the top, they should be carefully sealed in; cable routing must be sealed using cable clamps or similar devices (Legrand Cabstop). These precautions should be followed in particular where an enclosure has entries both at the top and the bottom, since a chimney effect could accelerate the growth of a fire.



Legrand lateral cable entry



## Safety in transport infrastructures and tunnels

Installing electrical equipment and conductor ducts in railway installations is subject to strict standards (EN 50125-X series) and regulations. Specific tunnel-related constraints (local pressure, vibrations, dusts, dynamic ground movements, spread of fire, etc.) must be very carefully reviewed. Signalling and telecommunications equipment must also meet requirements concerning ice formation, snow and hail, lightning and solar radiation.

Regulations have been tightened in road tunnels following a number of accidents. For example in France, interministerial circular no. 2000-63 of 25 August 2000 specified the requirements applicable to various equipment and particularly to conductor ducts which must be rated M1, with the cables themselves rated C1 as a minimum and CR1 when used in safety circuits. Furthermore, in order to protect emergency services from hazardous items falling, suspension devices carrying heavy items (indicator panels, ventilators, cable trays, etc.) must withstand a temperature of 450°C for 120 minutes on a standard heating curve CN 120 (or see ISO 834). Taking truck fires into account can lead to much stricter requirements, since such a fire can reach 1200°C in 10 minutes. There are therefore many elements which must be perfectly understood for use in these specific installations.





### Calorific potential of conductor ducts

Conductor ducts can present high or very high calorific loads when used for long lengths and with large-sized or multiple cable trays.

The calorific potential should be calculated accurately using manufacturer data, taking into account the number and type of cables used.

In practice these are not easy calculations and it may be sufficient to use fixed values if the customer and supplier reach an agreement to that effect.

For informational purposes only, the graph opposite shows an average value of linear calorific potential (in MegaJoules per metre of length of cable ducts) depending on cable tray width and the type of circuits used.

Note: it is worth noting that data conductors (computer and communication cables, etc.) have a high proportion of insulating material (70%) compared to the amount of copper (30%); this is almost the opposite of proportions found in electrical power conductors. These very thick cable ducts can constitute significant loads.

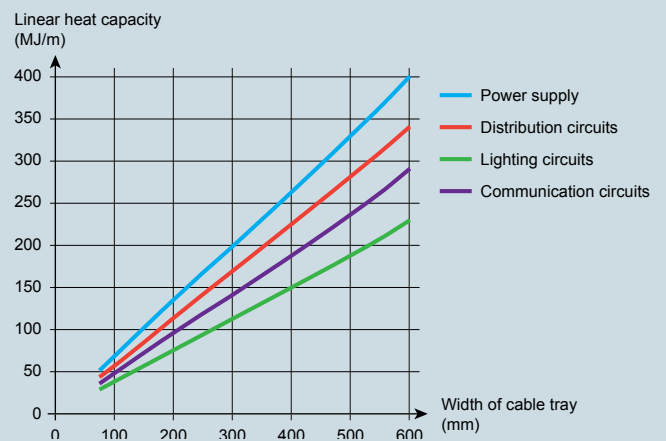

### E90 certification in accordance with the DIN 4102-12 standard

In the absence of other European or international standards of the same standing, this standard acts as a reference point and provides a means of classifying cable tray systems according to their level of fire resistance: E30, E60, E90. This figure denotes the duration of the test in the oven, the temperature reaching 1000°C at the end of the test according to a curve considered to reflect the natural development of a fire.

This fire resistance certification is unusual in that it does not apply to individual components but to a typical complete system with normal usage conditions using cable settings and loads with determined characteristics.

For example, Cablofil cable trays are E90 certified for many configurations covering the majority of assembly types: suspended, on brackets or on hanging fittings for light, medium or heavy loads.



Cablofil cable trays inside the oven before the test

### 3.6 Wall feedthroughs

Compartmentalisation is one way to obstruct the development of a fire by sealing volumes and thereby preventing it spreading. Regulations typically define the technical criteria to be followed when creating fire compartments by fire resistance duration categories known as "fire ratings" that are expressed in hours. When cables or ducts pass through walls, floors or ceilings with a prescribed fire rating (½ hr, one hour etc), it is vital that these elements maintain their original rating after they are penetrated so that the building's safety performance is not affected. Clearly the ideal solution is to review and plan conductor ducts and their wall feedthroughs during a building's planning stage. In reality, changes in usage often require multiple alterations, reconfigurations or removals to be made, requiring minor or major modifications to be implemented in the installation, from the simple feedthrough of additional conductors in existing ducts to the addition of new ducts altogether. During these alteration works priority tends to be given to the electrical aspect of the work rather than to fire safety, particularly given the fact that the constraints imposed by the existing infrastructure are coupled with the requirement to maintain operating continuity. A number of fires are caused by the lack of any upgrade following multiple works where the objectives and the original performance levels have been forgotten with the changes over time. Restoring the "fire rating" is thus a crucial operation.

#### > Cable tray feedthroughs and trunking

The underlying principle is the need to fill the cavity created by the duct, both externally and internally. The latter can be waived if the interior section does not exceed 710mm<sup>2</sup> and if the duct has at least an IP 33 rating, including at its end. Where possible, the cables should also be protected over a distance of at least 20cm on either side of the feedthrough. Although the EZ-Path system performs particularly well (see above) there are also other solutions that can be used. These are often simple measures, the efficiency of which is largely dependant on the quality of the implementation.



### The EZ-Path® system

**Cable entry through partitions, walls and ceilings must be implemented in such a way that the original levels of fire resistance and protection from gas leaks before cutting are maintained. Conventional measures may be taken (see opposite) but these do not allow easy alteration to the installation in future: it is impossible to feed through a new conductor without destroying the original firestop.**

**The EZ-path® fire module is a solution designed to meet both sets of requirements.**

**The EZ-Path® module contains an intumescent foam which reacts instantly in temperatures above 177°C or in the direct presence of flames. In less than a minute, the volume of the foam increases to 16 times its original size, creating a secure and durable barrier to fire and combustion gases.**

**EZ-Path® modules are available in three sizes and can be removed if the installation requires alteration at a later stage. The fire rating is maintained in all situations. Fire classifications are stated according to the standards used as references for testing.**

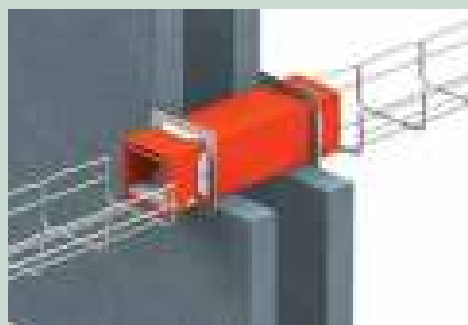

#### • Intumescent pads

These have a special feature in high temperatures, whereby they inflate to form a type of non-combustible and thermally insulating foam. They can expand to up to 8 or even 10 times their volume.

They prevent the spread of fire by blocking off the wall or partition feedthrough. The chemical reaction of intumescence is accompanied by heat absorption. Except in the case of vertical feedthroughs, the pads are simple to fit, making it easy to add further cables without making new cavities.

However, the risk remains of failing to replace the pads or fitting them incorrectly once the cables have been fed through.

It is also possible to use malleable intumescent plaster or mastics in cartridge guns, but it is important to take their maximum temperature into account.



**Filling of a fire barrier partition feedthrough with plaster and intumescent paste**

• **High density mineral wools (140 kg/m<sup>3</sup>)**

These offer good temperature resistance (around 1,000°C). However, installing panels can be problematic in irregularly shaped cavities, and their relative mechanical fragility does not always permit them to be reused properly after additional cables have been fed through.

Be sure to avoid the use of low density glass wool as insulation as this has a low melting point in relation to the temperatures reached in a fire.

• **Plasters**

These are rightly considered to be one of the best protections against fire and rising temperatures. Composed of gypsum and water, they are non-polluting and non toxic.

Plasters are used in the form of plasterboard (for fire sleeves, partitions, etc.), as a surface coating or as a filler.

The quality of the installation must be perfect in order to avoid leaving any cracks, as any further modifications will require the plaster to be broken. Filling in the cavity in direct contact with the cables is not advisable due to the risk of the filling being only partial and the grip on certain types of cable insulation being inadequate.

> **Prefabricated busbar feedthrough**

As long as the filling around the sleeves is completed correctly (for example with plaster), prefabricated busbars with a protection rating of at least IP 54 ensure wall feedthroughs do not promote the spread of flames. However, it should be noted that this type of filling is not sufficient to guarantee a compliant fire rating. Instead, thermal insulation should be placed carefully over an adequate length along the emerging sides of the busbar, so that the temperature of the metallic enclosure on the non-exposed side of the wall does not exceed the authorised limits (140°C). Without official certification from a qualified body for a layout of this kind, the best solution is to use fire-barrier elements as recommended by the manufacturer.

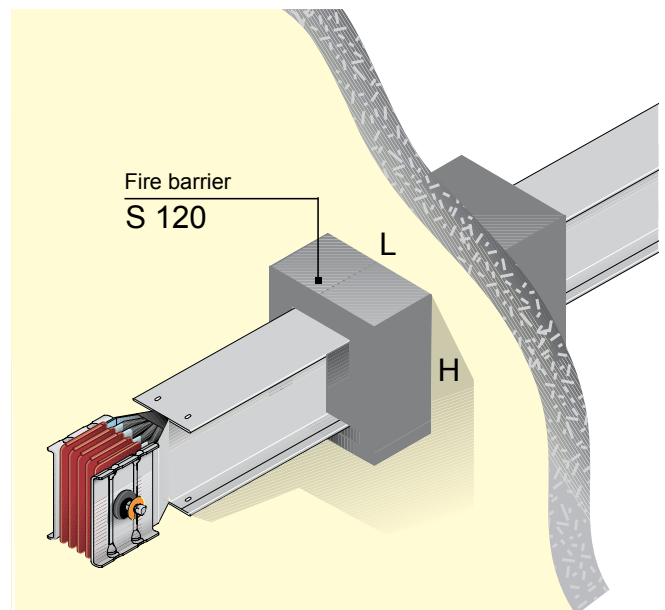

**Class S12 fire barrier for Legrand SCP busbars**

Legrand fire barriers are certified to class S 120 (in line with the DIN 4102 standard part 9), both for aluminium and copper busbars. They can be installed on all busbar elements (straight and angled lengths) as long as the instructions in the following diagrams are followed.

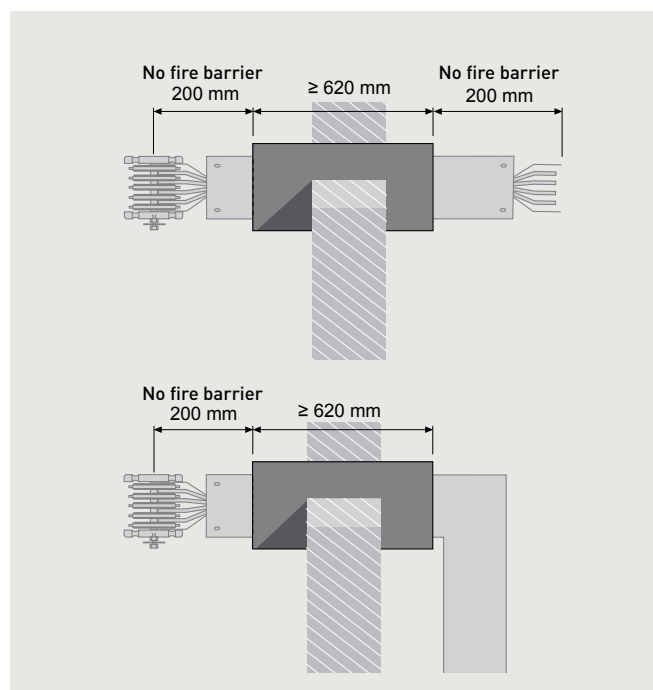

Fire barriers are a minimum of 620mm in length and must always be centred in the fire partition or flooring which is fed through. Once the fire partition or flooring is fed through, the openings must be carefully filled with material which complies with the appropriate fire safety regulations for the building.

In order to ensure the maximum fire rating, certain sizes of busbars should have an internal fire barrier installed in the factory (see table below). Therefore when placing an order it is important to indicate which elements will feed through fire walls or flooring.

Use of internal and external fire barriers					
Aluminium busbars			Copper busbars		
In (A)	Internal	External	In (A)	Internal	External
630	•	•	800	•	•
800 - 2000	-	•	1000 - 2500	-	•
2500 - 4000	•	•	3200 - 5000	•	•

Minimum sizes are recommended for the cavities formed in order to facilitate implementation of wall feedthroughs and filling operations once busbars have been installed (see table below)

Recommended sizes for wall cavities (mm)					
Aluminium busbars			Copper busbars		
In (A)	Width	Height	In (A)	Width	Height
630 - 1250	280	270	630 - 1250	280	270
1600	280	310	1600 - 2000	280	310
2000	280	360	2500	280	360
2500	280	520	3200	280	520
3200	280	580	4000	280	580
4000	280	620	5000	280	620

# Further precautions and constraints (continued)

## ELECTRICAL CONTINUITY AND EARTHING

Cable tray, ladder and all support devices for conductors and also the enclosures of prefabricated trunking constitute accessible earths with very significant dimensions. Although the cables and the conductive parts that they protect are often double insulated (cables U1000 R02 V for example), the rule is still to consider these earths as potentially dangerous and to apply class I protection rules.

Exposed conductive parts must be electrically connected to one another so that no dangerous voltage can arise between exposed conductive parts that are simultaneously accessible. The equipotential assembly thus constituted must be linked to a protection circuit as part of a linkage to earth system (TT, TN or IT).

### 1 CABLE TRAY

The continuity of cable tray may be obtained by construction or by the use of equipotential link conductors.

In practice, the two principles are often used together: short lengths are assembled by mechanical means, ensuring the continuity of one section to the next and the run is often connected to an auxiliary conductor over its whole length, using appropriate devices.

### 1.1 Electrical continuity through construction

With regard to regulatory requirements (see box), cable tray and prefabricated trunking earths can be used as a protective conductor when there is a continuous and reliable conductive structure of sufficient dimensions.

Connection devices and means must therefore be provided, including for equipment that might be installed later.

The links between the different sections must be protected against mechanical, chemical and electrodynamic deterioration. The risk of a section becoming disconnected and resulting in an interruption of the protection circuit must be prevented.

**!** Attention should again be drawn to the fact that the practice where cable tray earths are used as a protective conductor poses numerous difficulties due to uncertainties with sizing (actual cable tray sections, current used, etc.) and with regard to implementation (fitting methods, assembly, permanence, etc.).



**Standards IEC 61537 (cable tray and ladder systems) and EN 50085 (profiled conduits and ducting) classify and declare products according to their electrical continuity characteristics. The fact that a product is made of metal does not mean that it provides correct electrical continuity. It needs specific measures and tests to demonstrate the fact (cross-section of the metal, contact values, etc.). Depending on custom and practice and the country, and**

**conditional on care being taken during construction, the metal earth of cable tray, ladder and profiles may be used to constitute a continuous equipotential conductor or protective conductor.**

**This practice is not allowed in France (NF C 15-100 section 543.2.3) and an additional so-called “auxiliary” conductor is required to ensure the safety and permanence of the link between the different cable tray sections; the risk of the interruption or dismantling of a section cannot be discounted completely.**

Conductive sections joined together in this way must have sufficient conductance, equivalent to that which would result from the use of conductors. This characteristic must be verified by testing continuity and resistance to short circuits.

### > Electrical continuity

Standard IEC 61537 prescribes a continuity test at 25A with a resistance measurement which must not exceed 5mΩ per metre and 50mΩ per single connection. In practice, these tests verify a minimum level of continuity but are not sufficiently stringent to guarantee the circulation of major fault currents (phase/earth short circuits). Nor do they sufficiently meet the requirements in terms of high frequency (HF) impedance with regard to electromagnetic compatibility (see page 59).



**Cablofil coupler systems provide mechanical assembly and electrical continuity, guaranteeing a resistance of less than 1mΩ; much better than the 50mΩ demanded by the standard.**



### > Resistance to short circuit currents

#### Verification by calculation

The actual cross-section  $S$  of the cable tray must allow the conducting of any short circuit current calculated on the basis of the maximum current limited by the device protecting the maximum current circuit and the tripping time for this device.

$S$  is calculated by the formula:  $S = \sqrt{I^2 t / K}$

$S$ : cable tray cross-section in mm<sup>2</sup>

$I$ : actual fault current value in A

$t$ : operating time for the protection device in s

$K$ : coefficient depending on the permissible temperatures in the constituent metal and the insulation.

For a maximum temperature in the cable run of 200°C at the end of the short circuit, take  $K = 58$  for steel,  $K = 105$  for aluminium.

Reduce these values respectively to 50 and 90 in the event of a risk of fire (max temperature 150°C).

#### Verification by analogy

In the absence of knowledge of any fault loop, even of the protection device, it will be checked that the conductive cross-section of the cable tray's constituent material is at least equal to that of the protective copper conductor that would be required for the installed power.

By way of a practical approach, the copper equivalent of the section of the material used could be checked by the formula:  $S_{\text{material}} = n S_{\text{copper}}$  (only valid for similar temperature and installation conditions).

Where  $n = 1.5$  for aluminium,  $n = 2.8$  for iron,  $n = 5.4$  for lead,  $n = 2$  for brass (Cu Zn 36/40).

# Further precautions and constraints (continued)

## 1.2 Electrical continuity per equipotential link conductor

The installation of a cable tray auxiliary conductor ensures that there is an interconnection between the sections and electrical continuity in the system. This conductor must be connected to the general equipotential link (origin of the installation) or to a collecting terminal for the protective conductors (main distribution board) or to any other location allowing the protection conditions to be met (see Book 3: structure of protection systems).

Note that the purpose of installing an auxiliary conductor is not to produce a protective conductor associated with conductive circuits in the routing of cables but to provide, in addition to an equipotential link between the various sections, the flow of a fault current which might result from accidental detachment or damage to the insulation on a conductor. Although such a probability is low, it must nonetheless be considered for equipment supplied by a distribution network in a TN or an IT neutral system without additional residual current protection. In the event of a fault between phases and the metal part linked to the protective conductor, this situation can result in the circulation of a short circuit current limited only by over-current protection devices. In an IT system, this risk only occurs with the second fault on another phase and the short circuit current remains lower than in a TN system.

Under these conditions, it must be checked that the earths concerned, the equipotential links and their connection to the protection circuit are capable of conveying the short circuit current limited by the protection device for a value equal to 60% of the presumed 3-phase  $I_{sc}$  ( $I_{k3}$ ).

It is necessary to check the adequacy between the limited thermal constraint  $I^2t$  through the protection device and that allowed by the equipotential link conductor.

+

### Connection accessories for equipotential link conductors



**Grifequip: aluminium for the simple and economical earthing of a protective conductor with a cross-section of between 6 and 35 mm<sup>2</sup>.**



**Grifequip 2: easy to install and equipped with a double safety device for protective conductors with a cross-section of between 6 and 35 mm<sup>2</sup>.**



**Bi-metal terminal: bi-metal connector for the safe and durable earthing of protective conductors with a cross-section of 16, 35 or 50 mm<sup>2</sup>.**



**Terminal bracket + bi-metal terminal: for earthing in compliance with the most demanding specifications.**

!

**Equipotential links made by conductors are usually independent of mechanical functions. To limit the risk that they might be broken following maintenance work, if possible, connections should be located close to fixings and should be clearly identified: bare conductors or with dual green/yellow colouring or identified at each end by these colours and marking close to the connections.**

**Indicative cross-sections for equipotential link conductors depending on the highest rated current in the routing, of the corresponding protection device and the presumed short-circuit value**

Type of protection device	Max rated current (A)	Presumed short circuit current I <sub>k3</sub> (kA)	Equipotential link minimum conductor size (mm <sup>2</sup> )	
			PVC-insulated copper	Bare copper
DX <sup>3</sup> modular circuit breaker	63	3	4	2.5
	125	6	6	4
DPX <sup>3</sup> or DPX moulded case circuit breaker	400	15	10	6
	1600	20	16	16
		35	25	25
DMX <sup>3</sup> non-limiting circuit breaker	≤ 6300	≤ 10	50	35
		> 10		50

## 2 PREFABRICATED BUSBAR TRUNKING



Earth continuity in prefabricated busbar trunking and its connection to the protection circuit are provided by the construction and assembly of the different sections by following the assembly instructions. Other than when requested, there is no specific bar for use as a PE conductor. It is the trunking's steel enclosure which performs this function.

Prefabricated busbar trunking is designed for a specific current and conductors are sized appropriately. Electrical earths used as a protective conductor use this same logic and the tables of characteristics (see pp. 78 to 103) can therefore give the resistance values for the protective conductor and its reactance with accuracy, and fault loop values between a phase or phases and the protective conductor.

# Further precautions and constraints (continued)

## OPERATING CURRENT AND VOLTAGE DROPS

### 1 PREFABRICATED BUSBAR TRUNKING

To calculate the actual current that will allow the choice of the busbar trunking, a certain number of data must be known:

- the type of supply: 3-phase or single phase
- the configuration of the supply to the trunking: from one end, from both ends, from the middle, etc.
- the rated supply voltage
- the number, power and  $\cos \varphi$  of the loads that must be supplied by the trunking
- the load simultaneity factor
- the load use factor
- the presumed short circuit current at the supply point
- the ambient temperature
- the layout of the bars in the trunking (on edge, flat, vertical).

For a 3-phase supply, the actual operating current is determined by the formula:

$$I_B = \frac{P_{TOT} \cdot Kc \cdot Ku \cdot d}{\sqrt{3} \cdot Ue \cdot \cos \varphi_{moy}}$$

where:

$I_B$  = operating current (in A)

$P_{TOT}$  = total active power installed (in W)

$Kc$  = simultaneity factor

$Ku$  = usage factor

$d$  = supply factor, determined as follows :

- 1 when the trunking is supplied from one end;
- 0.5 if it is supplied from the middle or both ends

$Ue$  = operating voltage (in V)

$\cos \varphi$ : average power factor.

The trunking will be chosen using the rated current immediately above the calculated current.

The rated current applies to a specific orientation of the trunking. However, the influence of the orientation may be ignored for short vertical sections in horizontal trunking (less than 3m long, for example).

The rated current for Legrand busbar trunking is given for an ambient temperature of 40°C.

For use at different temperatures, a coefficient  $K_1$  must be applied to the rated current.

Coefficient of correction $K_1$ depending on the ambient temperature										
Temperature (°C)	15	20	25	30	35	40	45	50	55	60
Coefficient $K_1$	1.15	1.12	1.08	1.05	1.025	1	0.975	0.95	0.93	0.89

### > Losses through Joule effect

Losses through the Joule effect are essentially due to the electrical resistance of the bars. Lost energy is transformed into heat and contributes to the heating of the trunking.

For three-phase:  $P = 3 \cdot R_t \cdot I_B^2 \cdot 10^{-3}$

For single-phase:  $P = 2 \cdot R_t \cdot I_B^2 \cdot 10^{-3}$

where:

$P$  = dissipated power per unit of length (in W/m)

$R_t$  = Linear resistance of phase bars measured at thermal equilibrium (in mΩ/m)

$I_B$  = operating current (in A)

For a precise calculation, the losses through the Joule effect must be calculated for each section between tap-offs by taking into account the actual current circulating in it.



### Standard IEC 61439-6

**Standard IEC 61439-6 is applied to prefabricated busbar trunking systems whose voltage does not exceed 1,000V ac or 1,500V dc.**

**It relates to all trunking that can be used for the production, transport, distribution or conversion of electrical power.**

**This standard only describes the tests relating to trunking and should be read in conjunction with standard IEC 61439-1. Just like the previous one, it also recognises that the assembler or system manufacturer may be different from the original manufacturer (see art. 3.10.1 and 3.10.2 of part 1).**

## > Voltage drop

If the trunking is particularly long ( $\geq 100\text{m}$ ), it is necessary to check the voltage drop.

According to standard IEC 61439-6, the voltage drop in 3-phase trunking may be calculated using the following formula:

$$u = k \cdot \sqrt{3} \cdot (R \cdot \cos \varphi + X \cdot \sin \varphi) \cdot I_B \cdot L$$

where:

$u$  = system composite voltage drop (in V)

$R$  et  $X$  = averages of the resistance and the reactance, (in  $\Omega/\text{m}$ )

$I_B$  = current of the circuit considered (in A)

$L$  = length of the circuit considered (in m)

$\cos \varphi$  = power factor of the circuit considered

$k$  = load distribution factor, calculated as follows:

- to calculate the voltage drop at the end of the trunking:

$k = 1$  if the load is concentrated at the end

$k = \frac{n+1}{2n}$  if the load is uniformly distributed

between  $n$  tap-offs

- to calculate the voltage drop at a tap-off situated at a distance  $d$  from the origin point of the trunking:

$k = \frac{(2n+1) - \frac{n \cdot d}{L}}{2n}$  if the load is uniformly

distributed between  $n$  tap-offs.

To simplify the calculations, Legrand indicates in the tables the characteristics and unit voltage drop  $K$ , according to the values of  $\cos \varphi$ .

The voltage drop at the end of the trunking can then be calculated using the following formula:

$$u = b \cdot K \cdot L \cdot I_B \cdot 10^{-6}$$

where:

$u$  = the voltage drop (in V)

$b$  = the current distribution factor depending on the way in which the circuit is supplied and the distribution of electrical loads along the trunking (see table below)

$K$  = the unit voltage drop (in  $\mu\text{V}/\text{m}/\text{A}$ ) for a given  $\cos \varphi$  (see technical data table)

$I_B$  = the operating current in the trunking (in A)

$L$  = the length of the trunking (in m)

**Current distribution factor "b"**

Supply from one end and load at the other end of the trunking	$b = 2$
Supply from one end and uniformly distributed loads	$b = 1$
Supply from both ends and uniformly distributed loads	$b = 0.5$
Supply from the middle of the trunking and loads at its ends	$b = 0.5$
Supply from the middle of the trunking and uniformly distributed loads	$b = 0.25$

### Example:

- Legrand SCP aluminium trunking, 3P+N

- Rated current  $I_n = 2,000\text{A}$

- Supply from one end

- Uniformly distributed loads

- Length  $L = 100\text{ m}$

- Operating current  $I_B = 1,600\text{A}$

-  $\cos \varphi = 0.85$

According to the above table, the current distribution factor "b" equals 1

The characteristics table on page 84 gives a unit voltage drop value of  $K = 28.7\text{ (V/m/A)} \cdot 10^{-6}$

The voltage drop at the end of the trunking will therefore be:

$$u = 1 \times 28.7 \times 100 \times 1\,600 \times 10^{-6} \approx 4.6\text{V}$$

i.e. a relative voltage drop below 400V:

$$\Delta u = 100 \times \frac{4.6}{400} = 1.15\%$$



# Further precautions and constraints (continued)

## 2 CABLES FITTED IN CABLE TRAYS OR DUCTS

The use of cable tray systems for power distribution requires detailed knowledge of electrical installation characteristics. Book 4 gives all the technical information for determining the permissible current in cables depending on their installation conditions in accordance with standard IEC 60364-5-52.

For installations with long runs, it is particularly important to check voltage drops.

If the voltage drop is greater than the permitted limit, it will be necessary to increase the section of the conductors until the voltage drop is less than the prescribed value. When the main cables in the installation are longer than 100m, the permissible limit values can be increased by 0.005 % per metre above 100 m, without this addition itself exceeding 0.5%. The value of the unit voltage drop  $v$  (in volts per ampere and for 100m), can be read directly in the tables (see Book 4).



### Supplying motors

If the installation supplies motors, it is advisable to check the voltage drop under start-up conditions. To do this, simply replace current  $I_B$  in the formula opposite with the starting current of the motor and use the power factor on starting. In the absence of more accurate data, the starting current can be taken as being  $6 \times I_n$ . The voltage drop, taking into account all the motors that may start at the same time, must not exceed 15%. Apart from the fact that too high a voltage drop can hinder other users of the installation, it may also prevent the motor starting.



### Permitted voltage drop limit values in cables and trunking

Standard IEC 60364-5-52 recommends a standard maximum value of 4%.

This value applies to normal operation, and does not take account of devices, such as motors, that can generate high inrush currents and voltage drops. More restrictive values may be required (lighting circuits, link between the transformer and the main breaking or protection device).



### Calculating voltage drops

The voltage drop  $u$  (in V) in cables is calculated using the following formula:

$$= b \cdot \left( \rho_1 \frac{L}{S} \cos \varphi + \lambda \cdot L \cdot \sin \varphi \right) \cdot I_B$$

where:

$b$  : coefficient with a value of 1 for 3-phase circuits and 2 for single-phase circuits

$\rho_1$  : resistivity of conductors (in  $\Omega \text{ mm}^2/\text{m}$ )  
0.023 for copper and 0.037 for aluminium

$L$  : length of the trunking (in m)

$S$  : trunking section (in  $\text{mm}^2$ )

$\lambda$  : linear reactance of the conductors (in  $\text{m}\Omega/\text{m}$ )  
0.08 for multi or single conductor cables in a trefoil arrangement, 0.09 for single conductor cables joined in a layer and 0.13 for separate single conductors.

$\cos \varphi$  : power factor  
0.8 in the absence of information

$I_B$  : operating current in the trunking (in A)

The relative voltage drop (in %) is calculated as follows:

$$\Delta u = 100 \frac{u}{U_0}$$

$u$  : voltage drop (in V)

$U_0$  : voltage between phase and neutral (in V)

## GROUPING CONDUCTORS IN PARALLEL

Above a certain current (usually several hundred amperes), the use of several conductors in parallel allows their cross-section to be limited and thus their handling made easier.

This technique, very often used for the conductors between the transformer and the main low voltage board, is also used for high-power outgoing connections. The use of prefabricated busbar systems is, however, recommended.

The arrangement of conductors in a triangle (or in a trefoil) provides the best balance, but is generally limited to two or even three conductors per phase.

Above this, the overlapping of layers limits cooling and installation in a bundle is preferable.



Legrand prefabricated busbar systems up to 5,000A



Careful layout of the cables complying with both the grouping rules and the precautions against fire



### Basic rules

If several conductors are arranged in parallel, they must be arranged in as many groups as there are conductors in parallel, with each group containing one conductor from each phase. The groups of conductors must themselves be installed close to each other. This proximity rule also applies to single conductors (phases, neutral and protective conductor).



3-phase distribution via the conductors in parallel must comply with the strict geometrical layout rules. This also supposes that all the conductors are of the same type, same cross-section and same length and that they do not include any tap-off in their route and cannot be supplied individually. In the event of failure to comply with any one of these conditions, the overall protection of the bundle of parallel conductors by a single device would not be possible; one protection device per conductor would then be necessary. It is recommended that the number of parallel conductors is limited as far as possible. Above four cables, it is preferable to use prefabricated busbar systems, providing a better distribution of currents.

# Further precautions and constraints (continued)

Layout of the conductors in parallel and correction coefficient as per IEC 60364					
Type of installation	Number of conductors per phase	fs(1)	Without neutral	Number of neutral conductors	With neutral
In trefoil	2	1		1	
				2	
	3	1		2	
				3	
	4	1		2	
				4	
	5	1		3	
				5	
	6	0.8		3	
				6	
In a layer	2	1		1	
				2	
	3	0.8		2	
				3	
	4	1		2	
				4	
	5	0.8		3	
				5	
	6	0.7		3	
				6	



With alternating current, electrical conductors have an impedance (expressed in Ohms) which is the complex function of three factors: resistance  $R$  (also called Ohmic resistance), reactance  $L\omega$  due to the self-inductance of the conductor, and capacitance  $\frac{1}{C\omega}$  (or capacitive reactance) due to running conductors together, which creates a capacitor.

It is considered that beyond  $240 \text{ mm}^2$ , the contribution made by reactance  $L\omega$  becomes the dominant factor in the impedance. The conductor therefore behaves like a receiver, shifting the current and the voltage. The illustration opposite is given for a phase shift of  $45^\circ$  ( $\cos \varphi = 0.5$ ). Resistance and reactance equal. It should be noted that, for these currents, the capacitance component can be ignored.

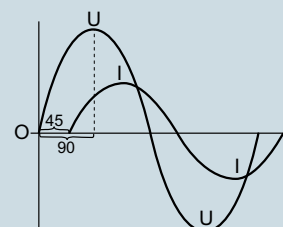

- Self-induction or own inductance coefficient ( $L$ )

It determines the electromotive force “e” circulating in a conductor following the variation in magnetic flux ( $\Phi$ ) surrounding the conductor.

The conductor’s inductance depends on the material’s magnetic characteristics, the medium and its geometry (length, number of turns):  $e = -L \frac{d\Phi}{dt}$

- Mutual inductance

For a symmetrical link, the self-induction coefficient is perceptibly identical for each conductor, this is:

$$L = (0.05 + 0.46 \log \frac{d}{r}) \text{ in mH/km.}$$

$d$  is the average distance between the axes of the conductors,  $r$  is the radius of the core of the conductor.

In an asymmetrical arrangement, since the distances are different, the mutual inductances between conductors will also be different.

From this, it follows that the distribution of the current will be asymmetrical.

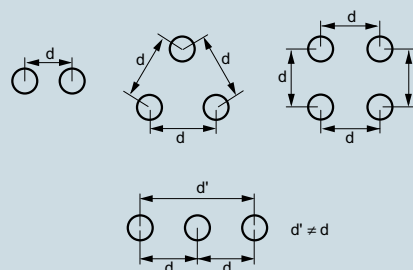

- Application to conductors in parallel

The equal distribution of currents in several identical conductors in parallel is uniquely linked to the equality of the impedances in each of the conductors. With the inductance proportion becoming dominant with the increase in section, the geometrical layout of the conductors will dominate (identical distances for each of them).

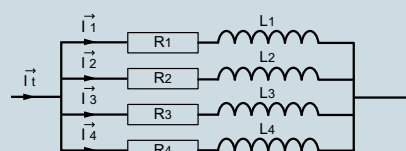

- Three-phase layout

In a cable or bundle of conductors in 3-phase (with or without neutral), the vectorial sum of the currents is nil and the resulting magnetic induction created by the conductors remains very low if they are grouped together and arranged in a regular pattern. If this is not the case, the self-induction coefficient of the conductors will be modified by the interaction of the magnetic field created. Own and mutual inductances and the distribution of the currents will then be out of balance.

# Further precautions and constraints (continued)

## PRECAUTIONS FOR SHORT CIRCUITS

There are two destructive effects which can affect conductors in the event of a short circuit:

- thermal stress, protection against which is normally provided by the limiting power of the protection devices (fuses, circuit breakers)
- electrodynamic stresses, whose forces between conductors can have destructive effects.

The indications given below, intended to draw attention to the importance of holding conductors securely, cannot by themselves guarantee that short circuit conditions will be withstood; these will require test simulation.

### 1 CONDUCTORS IN CABLE TRAY

When a short circuit between two active conductors occurs (the most probable), the conductors suffering the intense current of the short circuit will be repelled with a force proportional to the square of the intensity. If they are poorly secured, they will start to whip and could tear out of their ties and touch another conductor or an earth causing a new short circuit with a highly destructive arcing effect.

Multi-conductor cables are designed to withstand the forces that could be exerted by these conductors. It is the use of single conductor cables that requires particular precautions.



Value of presumed short circuit	Wiring precautions
$I_{sc} \leq 10 \text{ kA}$	No specific precautions.
$10 \text{ kA} < I_{sc} \leq 25 \text{ kA}$	Conductors must be attached using cable ties. Wires for a single circuit may be twisted together.
$25 \text{ kA} < I_{sc} \leq 35 \text{ kA}$	Conductors in a single circuit must be held separately and attached singly. If they are twisted together, the number of cable ties should be increased (one per 50 mm length).
$35 < I_{sc} \leq 50 \text{ kA}$	Conductors in a single circuit must be attached singly on a non-damaging rigid support (cross-piece, profile). They are physically separated. Each attachment point comprises two crossed cable ties.
$I_{sc} > 50 \text{ kA}$	At these short circuit values, forces become such that the securing means must be specially designed: machined cross pieces and threaded rods, for example. Legrand stainless steel profiles and clamps can be used under these extreme conditions.

## 2 PREFABRICATED BUSBAR TRUNKING

Even if there are few limitations in the use of prefabricated busbar trunking, it is still important to check that its short circuit resistance characteristics are actually coordinated with its upstream protection devices.

The trunking must be able to withstand the thermal stress associated with the short circuit for the entire duration of the fault, i.e. for the whole of the time necessary for the protection device (circuit breaker) to trip.

Similarly, the electrodynamic forces permitted by the busbar trunking must be compatible with the peak current limited by the upstream protection. The presumed peak value ( $I_{pk}$ ), can be determined by reading devices' limiting curves (see book 12) or in the absence of data, by applying an asymmetry factor  $n$  (see table below) at the effective value of the short circuit current ( $I_{sc}$ ).

Effective value of the short circuit	$\cos \varphi$	$n = I_{pk}/I$
$I \leq 5 \text{ kA}$	0.7	1.5
$5 \text{ kA} < I \leq 10 \text{ kA}$	0.5	1.7
$10 \text{ kA} < I < 20 \text{ kA}$	0.3	2
$20 \text{ kA} < I \leq 50 \text{ kA}$	0.25	2.1
$I > 50 \text{ kA}$	0.2	2.2

As with trunking made up of conductors and cables, presumed short circuit current calculations and the determination of protection devices must be done prior to any installation (see book 4).



**Prefabricated busbar trunking is constructed to withstand the electrodynamic stresses caused by short circuits within the limits indicated by the manufacturer.**



**Legrand Easybar, LBplus prefabricated busbar trunking and MS up to 100A, are fully protected against short circuits by the installation of a circuit breaker with a rating equal or lower than that allocated to the trunking. This protection is guaranteed up to the limits of the circuit breaker's breaking power.**

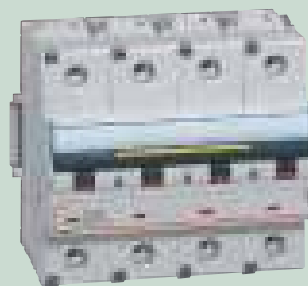

# Further precautions and constraints (continued)

## PRECAUTIONS WITH RESPECT TO MAGNETIC EFFECTS

Passing high currents through conductors induces magnetic effects in adjacent metallic masses, which can result in the unacceptable heating of the materials.  
 Few wiring precautions are therefore essential. To reduce the induction created, it is necessary to arrange the conductors so that the field is as weak as possible.  
 So far as is possible, conductors should be arranged in a trefoil to reduce induced fields. (see diagram for grouping conductors in parallel p 54).  
 To prevent significant heating in cable tray sections, it is advisable to remove the parts that create loops around a conductor.  
 Breaking the magnetic loop by removing sections is also possible.  
 In all cases, check that the mechanical strength remains acceptable.

**!** Magnetic loops

**In order to minimise the induction created in magnetic loops, it is still recommended that all the life conductors in a circuit (phases and neutral) should be positioned within the same metal (steel) compartments. Since the vectorial sum of the currents is nil, the one of the fields created is too.**

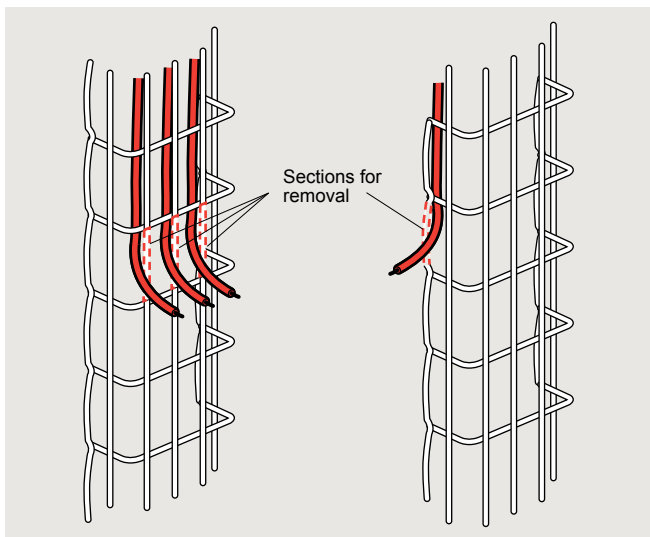

**Cutting wire cable tray in order to prevent magnetic fields likely to cause heating.**

**The circulation of a current  $\vec{I}$  in a conductor creates a proportional field  $\vec{H}$ , the effect of which is to create induction  $\vec{B}$  in the surrounding medium. The value of  $\vec{B}$  depends on the value of the field (therefore on the current) but also on the magnetic characteristics of the medium or the material; it is the magnetic permeability  $\mu$  expressed in henries per metre (H/m). The more the permeability of the material increases, the more the field lines are concentrated and the higher the induction. Above a certain value there is saturation and heating. Ferrous materials (steel) being magnetic by nature, are particularly likely to conduct fields but also to become saturated if these fields are too high.**

## ELECTROMAGNETIC COMPATIBILITY

The search for an overall optimisation of the installation with regard to electromagnetic compatibility (EMC) and its ability to function without suffering or emitting excessive interference, comes via a set of good practices, which are often simple and based on common sense. They apply to power and to communication conductors, and to both where they have to cohabit.

For a more complete approach to EMC phenomena, it is worth referring to the appropriate chapter in Book 8. Essential components in the installation, metal cable tray and prefabricated trunking contribute to the control of EMC in several ways:

- they constitute a common, continuous and distributed potential reference, by integrating into the installation's earthing system,

- they provide an interference reduction effect by reducing couplings due to proximity or the interposing of conductive elements,

- they enable the geometrical separation of circuits and functions and also compliance with minimum cohabitation distances between high and low currents and between polluting and sensitive circuits. It should be noted that insulating ducts and tray also have this advantage,

- through their screening effect, they can limit the electromagnetic radiation received by conductors or radiated into the surrounding area. This characteristic depends a great deal on the model; wire tray does not have any intrinsic screening qualities while Legrand prefabricated trunking is particularly effective on this point.



**Cable tray, trunking and more generally products intended for the transport and distribution of energy and communications in installations are considered as passive elements for EMC purposes.**

**This is undoubtedly a slightly simplistic view, given that conductors operate as aerials which radiate and receive and that they are subject to multiple couplings. But at the same time, EMC phenomena are highly complex to analyse within an overall installation; the routes taken by conductors and what they are exposed to are diverse and variable.**

**The latest European EMC directive (2004/108/EC), which came into force on 20 January 2005, identified this reality by extending its field of application to the whole installation and not just to products, even if the applicable verification tests in this area have remained insufficient until now. Powerful digital simulation tools exist but they are complex and not very accessible.**

### 1 ELECTRICAL CONTINUITY OF CABLE TRAYS

Where it is correctly inter-connected and connected to the installation's general equipotential link, metal cable tray contributes to the constitution of a common distributed potential reference, with a low impedance, which improves the quality of the installation's general earthing system.

Apart from contributing to safety (see p. 46), care taken over the continuity of runs allows the spread of (HF) interference within the installation to be limited; those travelling naturally to earth via the path of least impedance, such as metal masses and conductive trunking.

Standard IEC 61537 requires electrical continuity in cable tray which is stated as being conductive. Maximum electrical resistance values are 5mΩ per metre and 50mΩ per joining contact. Even though the first value is compatible with the right conductivity for HF interference, the second is much too high; a maximum target value of 1mΩ must be sought and a value of 5mΩ should not be exceeded under any circumstances.

# Further precautions and constraints (continued)

## 1.1 Physical continuity of cable tray

Wire joints are to be avoided due to their high impedance at high frequencies. It is recommended that continuity is produced by using appropriate items that produce much more effective wide and flat contacts.

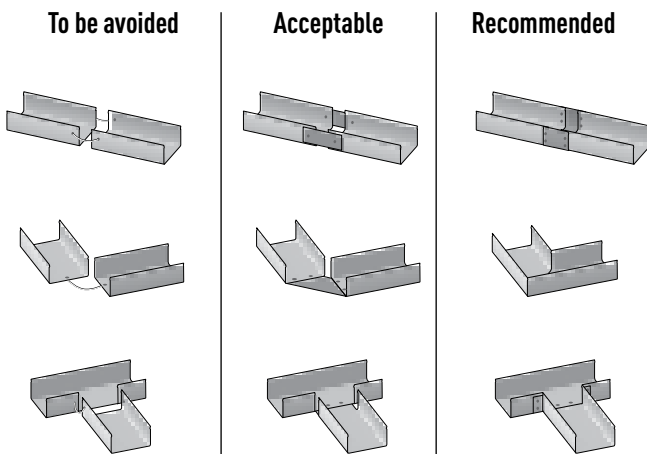

**Elbows, tees and joining or change-of-plane accessories, and similarly for the coupler systems on P31 sheet steel ducts and Cablofil cable tray, have been designed to ensure optimum equipotential continuity to provide better EMC performance.**



## 1.2 Star earthing system and common mesh system

Standard EN 50174-2 gives information on three levels for producing equipotential and earthing systems for communication installations. The search for maximum meshing reduces the impedance of the various circuits and equipment. This star earthing system is usually used in small installations. It only relates to distributed protection conductors, in a star, from the installation's origin. Equipment items do not communicate with each other or, if they do, they only do so locally; we then talk about a star multiple mesh system (see diagram on next page). In a common meshing system, it is the whole installation where conductive items, earths and protective conductors are meshed. The practical details of producing equipotential networks are described in the EMC chapter in Book 8.

### > Star earthing system structure

As a general rule, when equipment items, but this is also true for cable tray, are remote from each other and are inter-connected by protective conductors, the earth network created has a low equipotential associated with a high common impedance between the various items. The nature itself of the protective conductors and their cross-section has only limited influence. By virtue of the star structure of the installation, they are too long, which results in too high a high-frequency impedance for the equipotential to be correct.

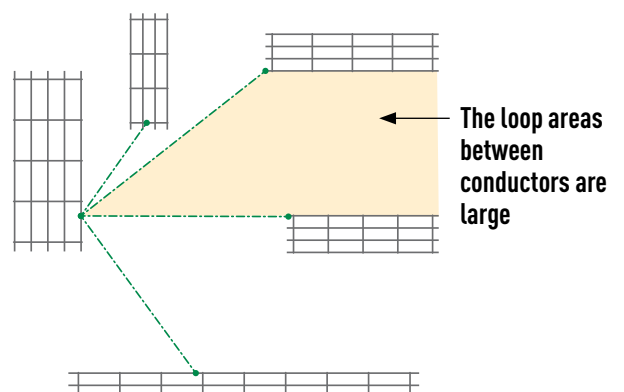

### > Structure of a common mesh earth system

In a common mesh earth system structure, metal cable trays are inter-connected to all available elements of the building's structure (frames, hangers, etc.). A search for the electrical continuity of routings must also be done by adding, if necessary, a few linking items (hangers, crossovers, cable tray sections) to provide better inter-connection.

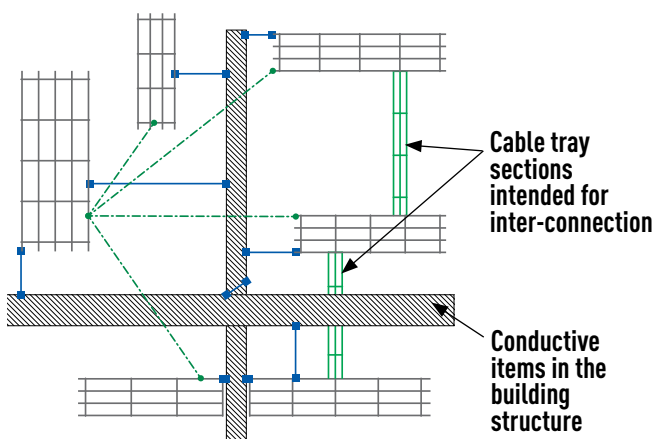

### > Star earth system structure with multiple meshes (variant of the star system)

Producing a full common meshing can be difficult (extent or complexity of the site, absence of conductive items) and it is sometimes preferable to deal with equipotential locally (unit mesh) for networks supplying certain equipment. In the example in the diagram below, the two distinct runs of power and communication systems supplying a single piece of equipment are made equipotential by a connection to accessible local earths and to the equipment itself.

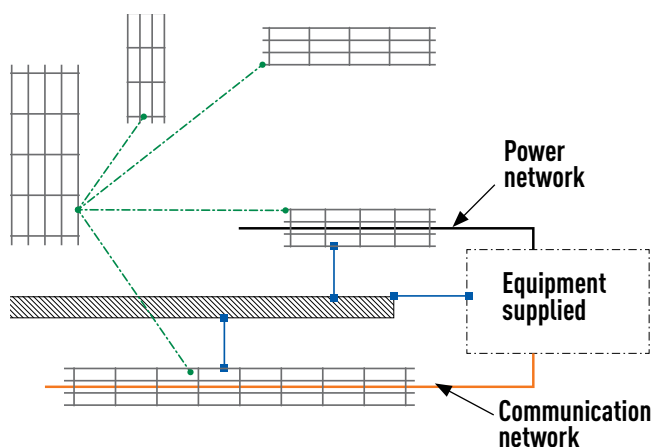

Connections between masses are preferably made by bolting on directly (paint removed, metal/metal and restoration of the protection) or by connection systems approved by manufacturers (joining components, couplers, penetrating devices, etc.). Short, wide conductors (braids, straps) may be used for shorter lengths (typically 0.5 to 1 metre) or for complex geometrical layouts. Round wire conductors should not be permitted beyond a few dozen centimetres.

In practice, any conductive element can contribute to the equipotential of the earthing network: protective conductors with their limits (high HF impedance), metal conduits, beams, frames, metal structures and door frames, ironmongery, gratings, conductive floors and of course cable tray, ducts and prefabricated trunking.

Attention is nonetheless drawn to the necessary permanence of these items, to their actual role and possible incompatibility for integration into the overall earth network. Some situations require a special analysis: presence of stray currents, return supply current, presence of lightning currents or particular interference, high immunity for hospital equipment, etc. Prior expertise is then necessary to assess the impact of the measures taken.



# Further precautions and constraints (continued)

## 2 REDUCTION EFFECTS

EMC good practice rules very often recommend positioning conductors as close as possible to masses or even pressing them against them, without however detailing the electromagnetic forces brought into play; we talk about a coupling reduction effect. In practice, it is especially communication conductors that can benefit from this effect.

This reduction effect has two aspects:

- an inductive aspect modifying the conductors' own impedance by reducing the self-induction component which increases with the frequency (see next page),
- a capacitive aspect reducing crosstalk with the other conductors by modifying the capacitive coupling; the metal element introduces a third armature in the capacitors which conductors form between each other.

Even more than for the inductive model, it is very difficult to quantify the capacitance value which these conductive elements represent which are complex impedances (both capacitor armatures and inductances).

### 2.1 Rule for grouping conductors

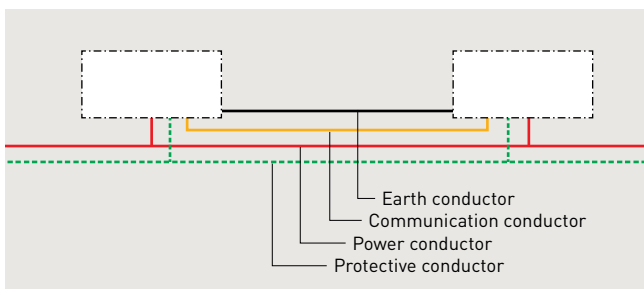

Too close cohabitation of conductors leads to couplings and the transmission of interference. Conversely, their being too far apart leads to poor equipotential and the creation of high surface loops.

As a compromise, it is preferable to route all conductors supplying a single system or devices communicating with each other relatively close together. This is particularly important for the protective conductor which participates in the capacitive coupling reduction effect. In particular, it must not be separated from the active conductors by ferromagnetic elements.

The active unit conductors must be arranged in such a way as to reduce their radiation and their mutual influence with other conductors. They themselves are also less sensitive to external interference, since they are coupled in common rather than differential mode.

To do this, the juxtaposed layouts (single-phase circuits) or trefoil (3-phase circuits) are recommended; those which are bundled for parallel conductors must follow strict rules (see pp. 53-54).

It is recommended that all types of conductor (signals, controls, power, but also equipotential links and protective conductors) are routed as close as possible to structures, frames, conduits, girders and other solid items, in order to benefit from a greater reduction effect, the more effectively these solid items are linked to the equipotential system.

If multi-conductor cables are used, non-connected conductors can be linked together and connected to the equipotential circuit. They will constitute a solid structure that will reduce capacitive couplings.



## Actual HF impedance of a conductor

This term covers two aspects: the apparent impedance of the conductor and the impedance of the field in which it is situated (whether or not it was generated by that conductor).

- The first notion is linked only to the characteristics of the conductor: its geometry (skin effect), the constituent conductor material (conductivity and magnetic permeability) but also the surrounding medium (permittivity of air) which will determine its characteristic impedance, which is a complex function of these elements but which can be simplified as:  $Z = L / C$  at HF.

For a single wire conductor, the impedance is reduced to its linear inductance and in air, this is approximately  $1\mu\text{H/m}$  (1 microHenry per metre) but it should not be forgotten that, in fact, this value is linked to the notion of the conductor's self-induction and that it only exists because a current is running through the conductor. Unlike an electrical field, magnetism only exists if there is a movement of charges (Maxwell's equations).

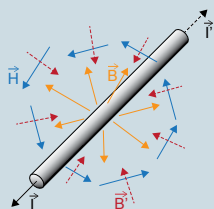

In the diagram opposite, the induction  $\vec{B}'$  generated by the field  $\vec{H}$  induces a self-induction current  $I$  which is opposed to the current  $I$  which originated it. Nothing prevents the self-induction (or own mutual induction) effect.  $L$  is approximately  $1\mu\text{H/m}$ .

NB:  $\vec{I}$  represents the current surge on breaking which makes cutting inductive circuits difficult.

The inductance phenomenon is like a brake. The field created by the conductor generates an induction in this same conductor which will conflict with the current that created it (Lenz's law), which explains clearly why inductance retards the current ( $\varphi < 0$ ).

- The second notion is linked to the propagation of electromagnetic waves in the surrounding medium which will have a direct influence on the self-induction of the conductor and therefore on its inductance. If the field is modified by the propagation medium (magnetic screen, other conductor, other field, etc.), the self-induction value will also be different from the actual inductance value. This is what happens when the return conductor is close to the outward conductor but also, and more generally, close to other conductive components, wires or earthing components.

The inductance of a conductor is therefore not an absolute value but is always a positive value; it depends largely on the reciprocal influences to which the conductor is subject.

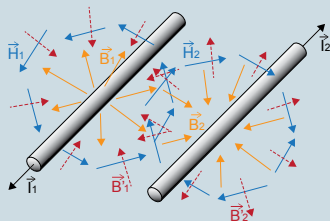

The diagram opposite shows the mutual influence of two conductors passed through by the same current but in the opposite direction. In a portion of the mutual influence space, the fields generated counteract each other, the inductions  $\vec{B}$  and  $\vec{B}'$  conflict, even cancel each other out and the self-induction of the conductor is reduced.

From what we see in this diagram, we can understand clearly that the mutual effects of induction, their own or mutual, are linked to the shape of the conductors, in particular, to their 'facing surfaces' in the case of outward/return conductors.

In single phase (two conductors) circuits, it is relatively easy to maintain this favourable arrangement, either by using cables, or by their side-by-side positioning. In multi-phase circuits, moreover, with several conductors in parallel, it is difficult to control all the mutual effects; that is why it is necessary to follow precise rules for their installation. (see pp. 53-54).

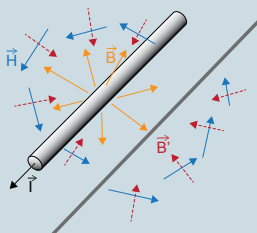

Reduction effect from the proximity of a metal mass

In the diagram opposite, the field  $\vec{H}$  must pass around the metal obstacle (in HF, the iron very quickly saturates and only the skin actually allows a field to pass). The magnetic circuit (a volume of air in this case) is lengthened and its magnetic resistance increases to the same extent. The induction value  $\vec{B}'$  which will be coupled to the conductor will be reduced. Note, however, that this does not mean that the value of the field generated  $\vec{H}$  is modified, it is simply the self-induction effect  $\vec{B}'$  which is counteracted.

# Further precautions and constraints (continued)

## 3 GEOMETRIC SEPARATION OF CONDUCTORS AND CIRCUITS

In terms of electromagnetic compatibility, a cable tray run can be compared to the routing of the tracks on a printed circuit board; a parallel which allows us to understand that there are no constant, universal rules and that most often, it is necessary to take a set of, sometimes contradictory, constraints into consideration, to determine what is the best compromise.

In the same way that the electrical separation of the supplies would be a means of limiting galvanic couplings between circuits with different intended uses, wide geometric separation would be the ideal means of avoiding capacitive and inductive couplings between conductors. But in practice, neither one nor the other is really applicable, and in all installations, there are a number of couplings or "common electromagnetic points".

### 3.1 The geometrical separation of circuits: between theory and common sense

To the extent that it is not possible to galvanically isolate circuits at their source (the power input is usually common) or at the point where they are used (in the example of communicating appliances), too systematic a separation of the conductors can lead to the creation of significant surface loops; the remedy can then be worse than the illness. Sufficient distances should be maintained between certain circuits while following

the rules for grouping together the conductors that make up these circuits (see p. 62)

Conductors on cable trays are subject to a set of interferences or are themselves the source of interference which depends on the frequency of the interference signal, the length of the common run and the distance between the conductors.

The coupling between conductors, generally referred to as crosstalk, is the result of several associated EMC phenomena (see Book 8). To this are added external phenomena such as magnetic (loop field), electrical (wire field) and mutual radiation.

Also, the nature of the conductors has a direct influence on the coupling:

- twisted pair (type UTP) to limit the inductive component of the coupling,
- screen (type FTP) to limit the capacitive component,
- shielding and screen (type SFTP) to protect from external electromagnetic radiation.

Standards EN 50174-2 recommend physical separation distances for the cohabitation of power and communication networks. These can be criticised for not taking into consideration the nature of the cable tray support, metal or insulating, or the level of pollution from the electrical circuit. The table below, based on experience, gives guide values for the principal installation and electromagnetic pollution situations.

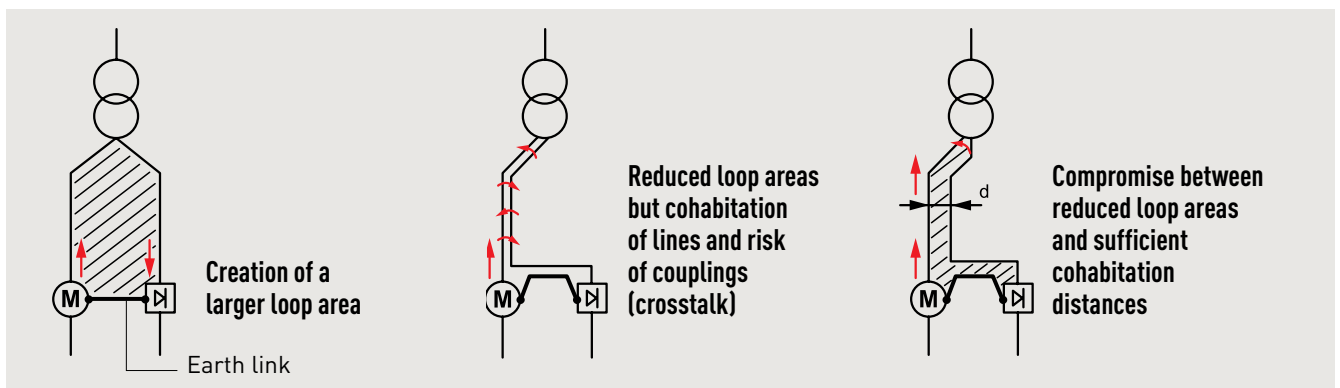

### Minimum recommended cohabitation distances d (in mm)

Power conductors		Communication conductors			
		Without screen		With screen	
Not very polluting	Without screen	<b>100</b>	50	0	0
	With screen	50	0	0	0
Polluting	Without screen	<b>300</b>	200	100	50
	With screen	150	100	50	0
Highly polluting	Without screen	<b>500</b>	300	150	100
	With screen	200	150	100	50
Nature of the support for the run		Non-metallic	Metal	Non-metallic	Metal

### 3.2 Cohabitation lengths

In practice, the minimum cohabitation distance depends on the length of the shared run. The more circuits cohabit over a long run (several dozen metres), the more it is important to comply with this distance. In fact, the frequency bandwidth that characterises the coupling between conductors is directly proportional to the wavelength of the frequencies in question and therefore to the length of the cohabitation.

For medium frequency disturbances (typically < 100MHz), the critical cohabitation length will be of the order of around ten metres; at a distance of one metre it will fall to disturbances at a frequency of one gigahertz. Also, high-frequency disturbances are predominantly electrical and attenuate far less quickly (in  $1/d^2$ ) than low frequency, predominantly magnetic disturbances (in  $1/d^3$ ).

### 3.3 Separation of certain devices

Some devices (fluorescent lighting, motors, welding sets, arc and induction furnaces, etc.) constitute local sources of pollution and cable trays and trunking should be kept away from them and vice versa. Contrary to what we read in certain publications, there is no ideal separation distance; everything depends on the level of pollution, the sensitivity of the circuits and the frequencies involved.

The values in bold in the table opposite may be used as a guide.

## 4 ELECTROMAGNETIC SCREENING OF CABLE TRAYS AND PREFABRICATED TRUNKING

By its nature cable tray does not constitute an ideal Faraday cage. And it is undoubtedly slightly ridiculous to want to guarantee electromagnetic screening performance for this type of product. For this to be the case their metal enclosure would have to be complete and continuous, with cable outlets themselves in continuity with the enclosure and joins between sections completely sealed against electromagnetic leaks.

Common sense should therefore lead to the use of shielded or screened conductors where necessary. The nature of the support for the run then has only limited importance. In all cases, the correct layout of the conductors with a view to limiting coupling does, of course, apply (see pp. 62).

# Further precautions and constraints (continued)

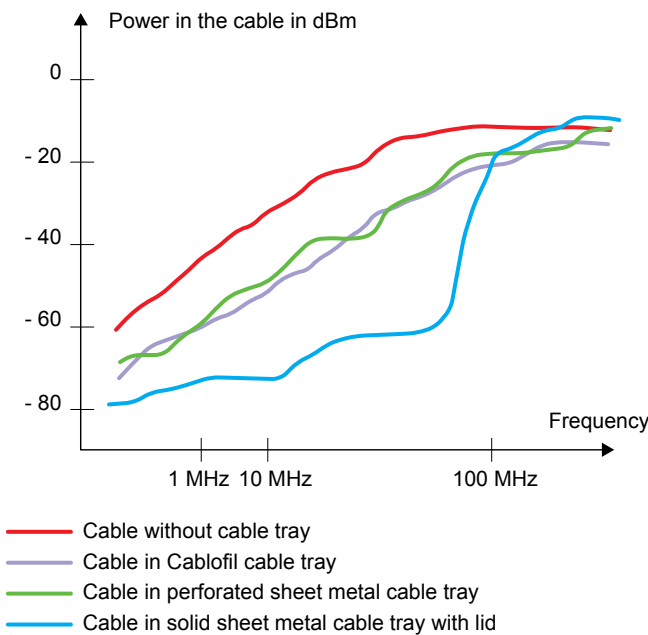

In practice, we can see that these provisions are not sufficient and that they have technical limits; the magnetic fields associated with cable tray carrying hundreds of amperes can reach several hundred microteslas. Admittedly, these values decrease rapidly with distance ( $1/d^3$ ) but they can remain above the thresholds fixed by the regulations in many countries (see inset box).

Unlike devices or machines which have a local effect and to which access can be limited to qualified personnel, power transport throughout buildings produces radiation along its length, including in areas that are unprotected, even those where the public has access. Radiated magnetic fields must now be controlled, which adds a new dimension to the choice of equipment used to convey energy. This can be a determining factor in the use of cable tray or prefabricated trunking.

Metal trunking with a lid provides some protection against radiated fields but it remains limited (approximately 40dB) and does not go beyond the area of frequencies below 100MHz.

It is nevertheless of value to use them for additional local protection (passing through a polluted zone close to a machine). Except with closed conduits or metal trunking, obtaining a constant level of screening throughout an entire installation is practically impossible.

## 4.1 Magnetic field emissions

Cable runs constitute sources of magnetic field emissions that become more and more significant as the current conveyed increases. In most installations on traditional wire or sheet metal cable tray, there is nothing that can be done to limit associated magnetic fields. In fact, they are produced by the layout of conductors that have to comply with certain positioning rules relating to electrical aspects (permissible current depending on mutual inductances) or electromagnetic aspects (couplings).



**Magnetic field values are currently expressed using two units.**

- The tesla (T) represents the magnetic induction value which, directed perpendicular to a surface of  $1m^2$ , produces a flow of 1 weber across that surface. The tesla expresses a very high value. Its sub-units are also frequently used, the millitesla (mT) and the microtesla ( $\mu T$ ).

The old unit, the gauss (G) should no longer be used ( $1T = 10,000G$ ).

- The ampere per metre (A/m), a non-SI unit and previously known as the “ampere-turn per metre”, refers to the intensity of the magnetic field created at the centre of a circular circuit 1m in diameter, carrying a constant current of 1 ampere.

The induction B (in T) and the field H (in A/m) are linked by the formula:

$B = \mu_0 \mu_r H$  where:

- $\mu_0 = 4\pi \cdot 10^{-7}$  (magnetic permeability of air or a vacuum)

- $\mu_r = 1$  (relative permeability of iron)

hence:  $1\mu T = 1.25A/m$  or  $1A/m = 0.8\mu T$



## Difficult regulations for levels of magnetic field

For a number of years Legrand has been studying electromagnetic power emission phenomena in busbar and conductor systems. In anticipation of future directives and regulations, Zucchini has been working since 1994 with the Chalmers University of Technology in Gothenburg to design and qualify prefabricated trunking whose radiated emissions are particularly low and which meet the strictest requirements.

Several documents with an international influence have guided national regulations on permissible exposure levels for persons to electromagnetic fields:

- "Guidelines for limiting exposure to time-varying electric, magnetic and electromagnetic fields (up to 300 GHz)" by the ICNIRP (International Commission on Non-Ionizing Radiation Protection),
- IEEE C95.6-2002 from the I.I.E.G.E. (Institute of Electrical and Electronics Engineers),
- Council Recommendation of 12 July 1999 on the limitation of exposure of the general public to electromagnetic fields (0 Hz to 300 GHz) (1999/519/EC) from the Council of the European Union,
- Document Reference: Directive 2004/40/EC of the European Parliament and of the Council of 29 April 2004 on the minimum health and safety requirements regarding the exposure of workers to the risks arising from physical agents (electromagnetic fields) from the Council of the European Union.

All these texts stipulate values for the workplace and public places (more restrictive) up to very high frequencies (300GHz). Magnetic field values (at 50 or 60Hz) are more consistent with maximum values of 100µT (Public) and 500µT (Workers) but it is also true that precise measurement conditions are not well defined. Some national regulations have introduced stricter requirements (Argentina: 25µT, Italy: 10µT even lower: 3µT as a target level), while others adjust values according to exposure time (Australia: 1000µT for several hours a day!). In premises where children are present, maximum levels may be reduced to 0.2µT (some regions of Italy) or 0.4µT (Netherlands). For American states, values vary greatly, with some tolerating very high maximum levels depending on the part of the body concerned and others using values close to European levels.

## 4.2 Magnetic radiation from prefabricated trunking

Legrand prefabricated trunking minimises electromagnetic emissions which are much lower than those generated by cables for an equivalent current.

The electrical field component is limited by the trunking system's metal enclosure, while the magnetic field component is very low by virtue of the arrangement of the conductors within the trunking.

In spite of possibly very high currents (up to 5,000A), the conductors are always positioned very close to each other. So, for the three bars, the current remains balanced and offset by 120°. The magnetic fields offset at the same angles cancel each other out; the magnetic emissions measured outside the busbar set remain extremely low.



It should be noted that even in difficult current-balancing conditions, the metal structure of the busbar enclosure will contribute to a large extent towards reducing any magnetic field present.

# Further precautions and constraints (continued)

The internal Legrand Zucchini laboratory certified LOVAG-ACAE (Associazione per la Certificazione delle Misure Elettriche - Association for the certification of electrical measurements) is able to carry out measurements of electromagnetic emissivity in prefabricated trunking. As laboratory tests done on the products show, the magnetic induction emitted by prefabricated SCP trunking is well below the  $3\mu\text{T}$  value measured at a distance of one metre from the bar.



Informative examples of several levels of exposure to magnetic fields at mains frequency (taken from the Italian standard CEI 211-6)		
Source	Magnetic induction ( $\mu\text{T}$ )	Distance (cm)
Electric razor	150 - 240	On contact
Hair drier	1 - 13	10 to 20
12V, 20W halogen lamp	0.5	30
Aerosol therapy device	20 - 50	20 to 30 cm
Electric blanket	2	On contact
Television set	0.3	50 cm
Washing machine	3.4	50 cm
Dishwasher	0.05	50 cm
Electric oven	0.4	20 cm
600W drill	2	On the chest
100W soldering iron	15.4	In the hand
225 W grinder	0.8	40 cm
1100 W compressor	8.2	40 cm
2150 W arc welding set	23.2	40 cm
75M W, 55-65k A, 150t arc furnace	100 - 270	Near
Electric scalpel	2.9	Near
Battery charger	22.9	Near
Ultrasound device	0.8	Near

The measurements taken at one metre from the bar and meeting standard IEC EN 61439-2, demonstrate that, under the most severe conditions (close to a connection), the magnetic induction generated by the busbar set is less than  $3\mu\text{T}$ .

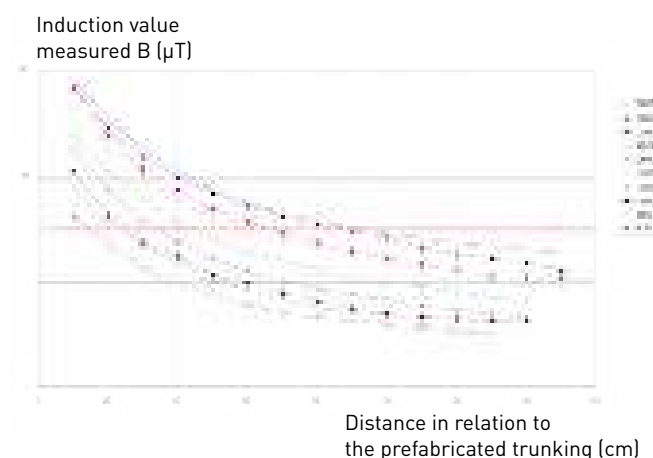

The studies conducted on the whole range show a very low level of emissions, meeting the strictest specifications, even at reduced distances: value for  $10\mu\text{T}$  (blue line) and target value of  $3\mu\text{T}$  (red line).

## PERMISSIBLE MECHANICAL LOADS

Standard IEC 61537 defines a series of obligatory tests that allow the maximum load to be determined for cable tray under normal use (SWL: safe working load). This value depends on the distance between the supports and the position of the couplers. It is the lower of the following two values:

- a uniformly distributed load causing a deflection of  $1/100^{\text{th}}$  of the span between supports
- breaking load divided by a safety factor of 1.7 if that deflection is not reached.

Manufacturers are required to advise these values to their customers. This is usually done in the form of diagrams.

**Example:** 60 x 200 mm cable tray, whose cross-section is therefore:  $6 \times 20 = 120 \text{ cm}^2$ , could be required to support a load of  $120 \times 2.5 = 300 \text{ N/m}$ . Consulting data supplied by the manufacturer will allow the maximum distance between supports to be determined which gives an SWL greater than that value.

Support accessories (brackets, hangers) are also subject to a load test in accordance with standard IEC 61537. The declared SWL of an accessory must cover the use of the maximum width of the cable tray for which it was designed. For different load conditions, the manufacturer or seller responsible must be consulted.



The permissible load in Cablofil cable tray is given for a deflection of  $1/200^{\text{th}}$  of the span, instead of the  $1/100^{\text{th}}$  required by the standard.

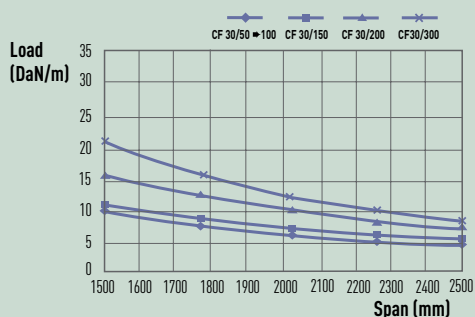

Example: diagram for 30 mm high Cablofil cable tray

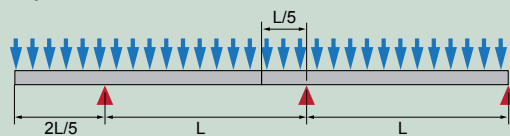

Test configuration: coupling at  $1/5^{\text{th}}$  of the span L

In practice, the final load which cable tray should support is not always known and can change as a result of changes to the installation. However, the usable volume of cable tray allows the maximum load that is likely to be placed on it to be estimated. This value is estimated at  $2.5 \text{ N/m}^2$  of cable tray section.



It is not permitted:

- for ladders, scaffolding or other objects to press against installed cable tray
- to walk on installed cable tray



Standard IEC 61537 defines four tests for fitted cable tray.

The type of test applicable depends on the installation recommendations given by the manufacturer.

- Test type I: when the manufacturer does not give any indication about any restriction relating to the end row or the position of single connections.
- Test type II: when the manufacturer states that there must be no single connection on the end row when making the installation.
- Test type III: when the manufacturer states the position of the single connection in relation to the end support for any installation.
- Test type IV: when the products have a localised zone of lower resistance.

# Prefabricated busbar trunking

Prefabricated busbar trunking is a safe solution for distributing high currents. It is also an ideal solution for supplying luminaires, when speed of installation is an important criterion. But prefabricated busbar trunking can also be used to produce the complete electrical infrastructure for commercial buildings by providing definite technical advantages over the usual method of installation.

## ARCHITECTURE OF AN INSTALLATION AND CHOICE OF RANGES

Legrand prefabricated busbars trunking are split into several ranges according to the power to be conveyed and can be used throughout the installation.

### > High power trunking

- HR (High Rating): from 1000 to 5000A
- SCP (Super Compact Painted): from 630 to 5,000A

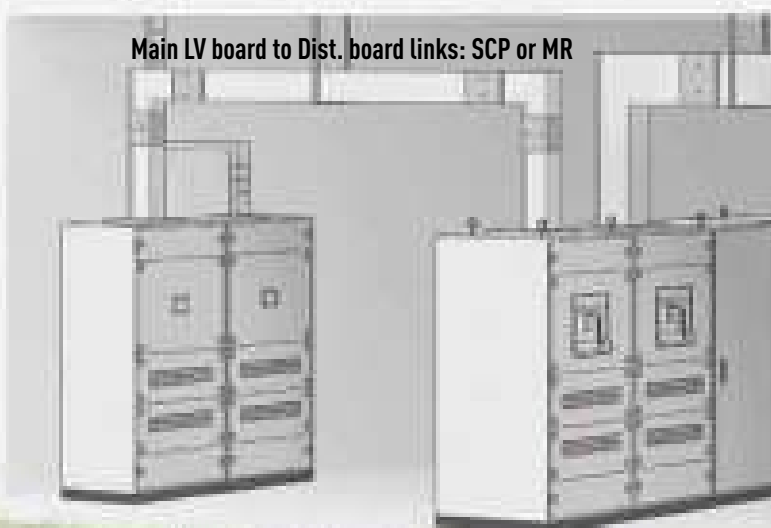

### > Medium power trunking

- MR (Medium Rating): from 160 to 1000A
- TS (Trolley System): from 63 to 250A
- MS (Mini System): from 63 to 160A

### > Low power trunking







- LBplus (Lighting Busway): from 25 to 63A
- Easybar: from 25 to 40A

Lighting: LBplus

Supply to offices: Easybar

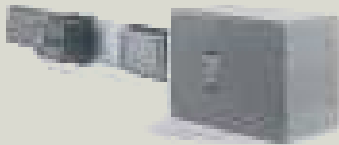
Power distribution, supply to production stations, handling: SCP, MR, MS or TS

Choice of Legrand prefabricated busbar trunking

Type of trunking	Rated current In (A)	Degree of protection	Applications						
			Transformer-main low voltage board connection	Main low voltage board-distribution board connection	Rising main	Machines	Small tools	IT work stations	Lighting
<b>HR</b> 	1000 to 5,000	IP30 IP31	●						
<b>SCP</b> 	630 to 5,000	IP55	●	●		●			
<b>MR</b> 	160 to 1000	IP40 IP52 IP55		●		●			
<b>MS</b> 	63 100 160	IP40 IP55				●	●		
<b>TS</b> 	63 125 160 250	IP20				●			
<b>LBplus</b> 	25 40 63	IP55					●	●	●
<b>Easybar</b> 	25 40	IP55						●	●

	Power supply		Junctions																
	Single phase	Three-phase	Type		Density		Current (A)							Type of protection					
			Single phase	Three-phase	High	Low	10	16	32	40	50	63	125 to 160	630 to 1,250	Without	Fuses	Modular circuit breakers	Moulded case circuit breakers	
		●		●		●								●	●		●		
		●		●	●	●								●	●	●	●		●
		●		●	●	●				●				●	●		●		●
		●		●	●	●			●	●				●	●		●		●
		●		●		●					●					●	●		
	●	●	●	●	●	●	●	●								●	●		
	●	●	●	●	●	●	●	●								●	●		



## Standard IEC 61439-6

Standard IEC 61439-6 applies to prefabricated busbar trunking systems (BTS) with a voltage not exceeding 1000V ac or 1,500V dc.

This concerns all BTS that can be used for production, transport or distribution, or electrical energy conversion purposes.

This standard only describes tests relating to BTS and must be read in conjunction with IEC 61439-1, which defines the general rules referenced in part 6.

Standard IEC 61439-1, defines the roles of the original manufacturer and the system assembler (see opposite).

The assembler may be a different organisation to the original manufacturer.

There then follows a list of verifications that can be done by testing, comparison or evaluation, by meeting the design rules under the responsibility of the original manufacturer or the assembler.

The main verifications are: heating limits, dielectric properties, resistance to short-circuit currents, effectiveness of the protection circuit, leakage lines and isolation distances, mechanical operation, degree of protection, mechanical strength, resistance to corrosion, fire resistance, electromagnetic compatibility, connections and terminals, protection circuit continuity. Also, and to obtain conformity with standard IEC 61439-6, requirements specific to BTS are added, in the form of tests aimed at defining the suitability of BTS for supporting mechanical loads, withstanding heat cycles, assessing fire resistance when passing through partitions, not spreading flames and remaining within the heating limits for BTS.

Particular attention is paid to voltage drop calculations, a penalising criterion in energy distribution. Homopolar impedance, resistance and reactance calculations are stated in the appendices to IEC 61439-6, like the determination of magnetic fields linked to BTS.

### Definitions

- **Original manufacturer:**  
entity that produced the original design and associated verification of an assembly in accordance with the standard (for example, Legrand)
- **System assembler:**  
entity that does the assembly and wiring and takes responsibility for the finished assembly (e.g. the installer or panel builder)

### Clearly defined roles

- The original manufacturer produces the various parts involved in the composition of busbar trunking systems: transport sections, feed boxes, junction boxes and/or of couplings, accessories. All these items come with product certificates of conformity.
- The assembler puts together the items that make up the distribution via busbars trunking, complying with the essential implementation rules stated in IEC 61439-6 (passing through a partition, mechanical stresses, etc.). It provides the guarantee and must certify the assembly as complete.

### Compliance

Full compliance with this approach can be certified by a declaration of conformity and the assembly be marked as a result.

## HIGH-POWER TRUNKING

Legrand offers two ranges of high-power trunking:

– **HR**: IP 30-31 trunking, used for the transport of high currents (connecting the transformer to the main board, for example)

– **SCP**: IP 55 compact trunking, used for all high current transport and distribution applications.

They both meet standards IEC 60439-1 and 60439-2 and offer speed, simplicity and flexibility, in respect of both installation design and implementation. They are available with copper or aluminium conductors.

A unit isolation test is done in the factory on each section by applying a voltage of 5kV between each conductor bar and between the bars and the trunking.

Both types of trunking use the same electrical connection system with single-piece connectors providing both speed and safety:

– silver-covered copper contact plates

– shear-head bolts (the head breaks off at a pre-determined torque)

– washers to ensure the correct distribution of the contact pressure and that it is maintained, even where there are temperature variations.



### Customised design

Legrand can carry out a free-of-charge design study for busbar trunking projects:

- complete costing for the supply of standard and custom busbar sections and any necessary accessories
- mechanical positioning drawing
- design of the connections with the transformer and with distribution board enclosures
- recommendations for types of fixing and taking measurements
- telephone assistance throughout the installation period.

• Information to be supplied for carrying out a customised design study:

- operating current
- type of application: transport or distribution
- number of junctions
- copper or aluminium bars
- degree of protection
- RAL colour for painted trunking
- neutral cross section
- ambient operating temperature
- positioning with dimensions: sketch or file

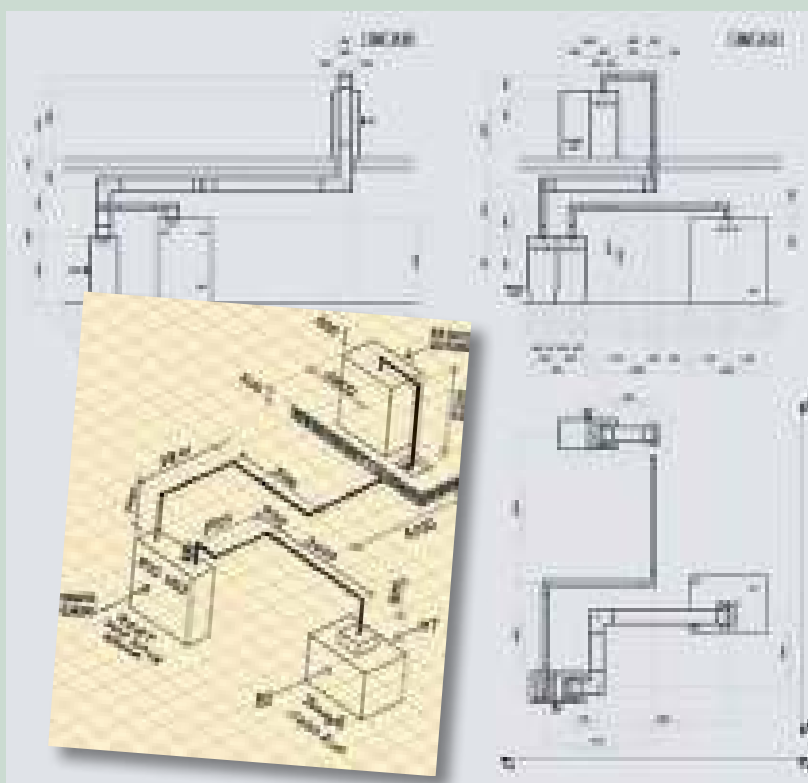

# Prefabricated busbar trunking (continued)

## 1 HR TRUNKING

### 1.1 Applications

This trunking is normally used to make the connection between the HV/LV transformer and the main low voltage board and for all high voltage connections in industrial and office buildings.

### 1.2 General characteristics

- Two versions available depending on the type of conductor bars:
  - electrolytic copper ETP 99.9 UNI EN 13601 ;
  - aluminium treated over its entire surface using galvanic processes (copper plating + tinning).
- Rated current of 1000 to 4,500A with aluminium conductors and 1000 to 5,000A with copper conductors (the rated currents are given for an average ambient temperature of 40°C).
- Enclosures made of four hot galvanised steel profiles, 2mm thick.
- Perforated enclosures to allow air circulation through the busbar set and to ensure effective heat dissipation.
- IP30 degree of protection (IP31 with special accessories). The mechanical connection between the sections is completed by lids fitted with seals to ensure the IP.
- Isolation of the bars by a double strip of insulating, non-drying film with very high dielectric rigidity.
- Holding and spacing of the bars by insulating glass-fibre reinforced resin insulating supports.
- Neutral section: 100% or 50% of the section of the phases depending on the sizes.
- Electrical connection between the sections by single-piece connectors fitted with pre-determined torque shear-head bolts.
- Protective conductor (PE) provided by the enclosure. Electrical continuity at the junctions is guaranteed.
- V1 self-extinguishing in accordance with standard UL94 and compatibility with the glow-wire test in accordance with EN 60695-2-1 for all insulating material components.

### 1.3 System composition

The wide choice of sections making up the HR trunking system allows it to be adapted to all installation configurations.

#### > Transport sections

Straight sections, vertical and horizontal elbows, double elbows (all orientations) and tees allow all, even the most complex, routings to be achieved. All these sections can be made to measure in accordance with the installation drawing.

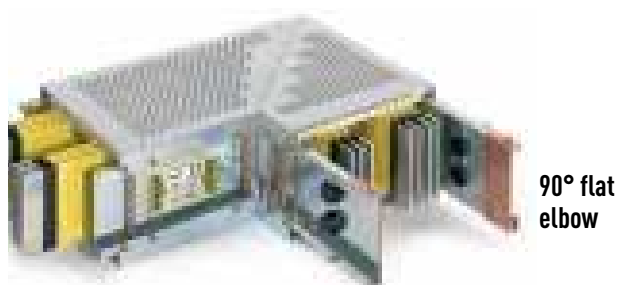

+

Integrated single-piece connectors and straight sections

**Straight sections are delivered with their single-piece connector pre-installed.**

**The standard length of straight sections is 3m.**

**Custom sections, between 500 and 2,999mm, may be fabricated to meet special installation needs.**

### > Special sections

- Sections with an S120 fire-break barrier for passing through fire-break partitions (see p. 43).
- Straight sections with expansion compensation. These have to be inserted in long runs, every 35-40m, to compensate for the thermal expansion of the building or the trunking.
- Straight sections with rotation of the phases or rotation of the neutral. These sections are useful for changing the position of the phases or the position of the neutral. They also allow the mutual reactance between the phases to be balanced and therefore currents in long trunking runs to be balanced (100 to 150m and longer).

### > Connection interfaces



Connection spreader with 90° elbow

The spreaders and feed units are fitted at the end of the trunking and allow the system to be connected to other sections in the installation.

Connection plates allow cables fitted with lugs to be connected or connection via bars in an electrical enclosure. The spacing between connection plates is 120mm.

### > Tap-off boxes (from 125 to 1,250A)

These allow supply to an occasional load or secondary circuit.

They are connected to the junction between two sections and are bolted to the trunking. They can only be installed when the trunking is not live.

They are available with an AC 23 isolating switch and fuse holder or with a moulded case circuit breaker.

### > Protective bellows and flexible braids

These allow trunking to be isolated from equipment that generates vibration (transformers, generators, etc.).

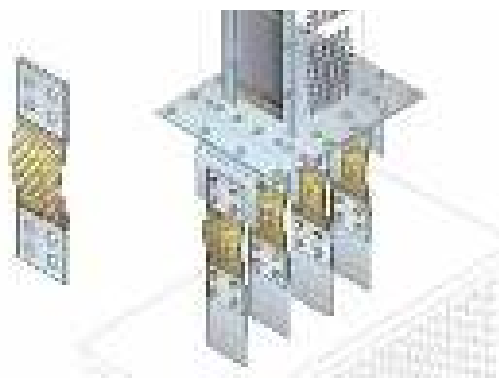

Legrand dry transformers have connection kits specially designed for HR and SCP trunking.

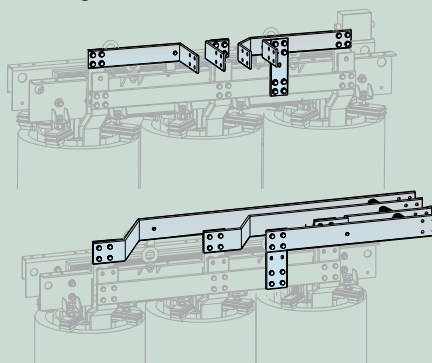

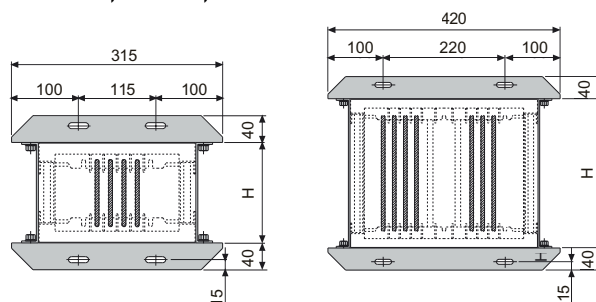

### > Fixing accessories

Fixing flanges appropriate to the size of trunking allow the installation of all types of support: suspensions, brackets, beams, etc.



# Prefabricated busbar trunking (continued)

## 1.4 Technical characteristics



Aluminium HR trunking											
Rated current (standard installation)	 In (A)	HR C1 3P + N 100% + PE (sleeved) single bars				HR C2 3P + N 50% + PE (sleeved) double bars					
		1000	1,250	1,600	2,000	2,250	2,500	3,200	4,000	4,500	
Rated current for different installation mode	  In (A)	700	875	1,120	1,400	1,575	2,100	2,240	2,800	3,500	
External dimensions	L x H (mm)	235 x 171	235 x 221	235 x 221	235 x 251	340 x 171	340 x 221	340 x 221	340 x 251	340 x 271	
Operating/isolation voltage	U <sub>e</sub> (V)	1000	1000	1000	1000	1000	1000	1000	1000	1000	
Operating frequency	f (Hz)	50/60	50/60	50/60	50/60	50/60	50/60	50/60	50/60	50/60	
Permissible short-duration current in a 3-phase fault (1s)	I <sub>CW</sub> (kA) <sub>eff</sub>	40	50	50	60	70	90	90	90	100	
Peak current permissible in a 3-phase fault	I <sub>pk</sub> (kA)	84	105	105	132	154	198	198	198	220	
Short-duration current permissible in a fault on 1 phase (1s)	I <sub>CW</sub> (kA) <sub>eff</sub>	24	30	30	36	42	54	54	54	60	
Peak current permissible in a fault on 1 phase	I <sub>pk</sub> (kA)	50	63	63	76	88	119	119	119	132	
Permissible thermal stress in a 3-phase fault	I <sup>2</sup> t (MA <sup>2</sup> s)	1,600	2,500	2,500	3,600	4,900	8,100	8,100	8,100	10,000	
Phase resistance at 20°C	R <sub>20</sub> (mΩ/m)	0.056	0.037	0.034	0.029	0.027	0.018	0.017	0.014	0.012	
Neutral resistance at 20°C	R <sub>20</sub> (mΩ/m)	0.056	0.037	0.034	0.029	0.054	0.037	0.034	0.029	0.024	
Phase reactance	X (mΩ/m)	0.087	0.066	0.066	0.053	0.049	0.034	0.034	0.024	0.024	
Neutral reactance	X <sub>n</sub> (mΩ/m)	0.087	0.066	0.066	0.053	0.098	0.068	0.068	0.048	0.048	
Phase resistance at thermal equilibrium	R <sub>t</sub> (mΩ/m)	0.076	0.050	0.046	0.038	0.036	0.025	0.023	0.019	0.016	
Protective conductor resistance	R <sub>PE</sub> (mΩ/m)	0.113	0.099	0.099	0.092	0.095	0.085	0.085	0.080	0.076	
Protective conductor reactance	X <sub>PE</sub> (mΩ/m)	0.130	0.130	0.130	0.130	0.110	0.110	0.110	0.110	0.110	
Phase-PE fault loop resistance	R <sub>o</sub> (mΩ/m)	0.189	0.149	0.145	0.131	0.031	0.110	0.107	0.099	0.093	
Phase-PE fault loop reactance (50 Hz)	X <sub>o</sub> (mΩ/m)	0.217	0.196	0.196	0.183	0.159	0.144	0.144	0.134	0.134	
Phase-neutral fault loop resistance	R <sub>o</sub> (mΩ/m)	0.132	0.087	0.080	0.067	0.090	0.062	0.057	0.048	0.040	
Phase-neutral fault loop reactance (50 Hz)	X <sub>o</sub> (mΩ/m)	0.217	0.196	0.196	0.183	0.208	0.178	0.178	0.158	0.158	
Voltage drop with uniformly distributed loads u = K · L · I <sub>B</sub> · 10 <sup>-6</sup> (V)	K (V/m/A)10 <sup>-6</sup>	cosφ = 0.70	99.9	71.1	68.5	56.1	50.3	36.2	34.9	26.5	24.6
		cosφ = 0.75	99.2	70.2	65.7	55.4	51.8	35.7	34.3	26.3	24.2
		cosφ = 0.80	97.9	68.9	65.9	54.2	50.6	35.0	34.5	25.8	23.6
		cosφ = 0.85	95.6	65.8	63.8	52.5	49.1	33.9	32.4	25.1	22.8
		cosφ = 0.90	92.0	63.7	60.6	50.0	46.7	32.8	30.7	24.1	21.6
		cosφ = 0.95	86.1	58.9	55.4	46.0	43.1	28.7	23.0	22.3	18.7
		cosφ = 1.00	65.8	43.2	39.6	33.0	31.4	21.6	18.8	16.6	13.9
Weight	(kg/m)	21.2	26.2	27.1	30.0	30.8	37.9	39.5	44.0	49.0	
Calorific power with regard to fire	(kWh/m)	4.1	4.1	4.1	4.1	6.6	6.6	6.6	6.6	6.6	
Degree of protection (IEC EN 60529)	IP	30-31	30-31	30-31	30-31	30-31	30-31	30-31	30-31	30-31	
Losses through Joule effect at rated current	P (W/m)	228	234	351	462	551	467	702	924	976	

Meets standards: IEC 60439-1 and 60439-2 [change to IEC 61439-6, see p. 74], DIN VDE 0660 parts 500 and 502  
Product can be used in a damp atmosphere (IEC 60068-2-3, IEC 60068-2-30)

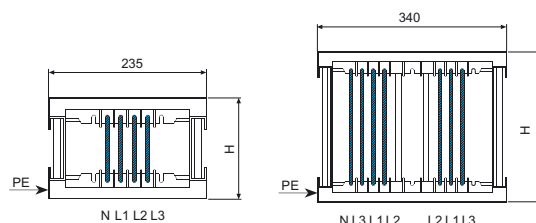
In: rated current for an ambient temperature of 40°C  
For use at a different ambient temperature, see p. 50



## Copper HR trunking

Rated current (standard installation)	 $I_n$ (A)	HR C1 3P + N 100% + PE (sleeved) single bars					HR C2 3P + N 50% + PE (sleeved) double bars				
		1000	1,250	1,600	2,000	2,500	3,000	3,200	4,000	5,000	
Rated current for different installation mode	  $I_n$ (A)	700	875	1,120	1,400	1,575	2,100	2,240	2,800	3,500	
External dimensions	L x H (mm)	235 x 151	235 x 171	235 x 181	235 x 221	235 x 251	340 x 181	340 x 181	340 x 221	340 x 271	
Operating/isolation voltage	$U_e$ (V)	1000	1000	1000	1000	1000	1000	1000	1000	1000	
Operating frequency	f (Hz)	50/60	50/60	50/60	50/60	50/60	50/60	50/60	50/60	50/60	
Permissible short-duration current in a 3-phase fault (1s)	$I_{CW}$ (kA)eff	40	50	50	60	70	90	90	90	100	
Peak current permissible in a 3-phase fault	$I_{pk}$ (kA)	84	105	105	132	154	198	198	198	220	
Short-duration current permissible in a fault on 1 phase (1s)	$I_{CW}$ (kA)eff	24	30	30	36	42	54	54	54	60	
Peak current permissible in a fault on 1 phase	$I_{pk}$ (kA)	50	63	63	76	88	119	119	119	132	
Thermal stress permissible in a 3-phase fault	$I^2t$ (MA <sup>2</sup> s)	1,600	2,500	2,500	3,600	4,900	8,100	8,100	8,100	10,000	
Phase resistance at 20°C	$R_{20}$ (mΩ/m)	0.032	0.029	0.028	0.021	0.016	0.014	0.012	0.009	0.007	
Neutral resistance at 20°C	$R_{20}$ (mΩ/m)	0.032	0.029	0.028	0.021	0.016	0.028	0.025	0.019	0.013	
Phase reactance	X (mΩ/m)	0.097	0.076	0.074	0.074	0.040	0.031	0.031	0.026	0.023	
Neutral reactance	$X_n$ (mΩ/m)	0.097	0.076	0.074	0.074	0.040	0.062	0.062	0.052	0.046	
Phase resistance at thermal equilibrium	$R_t$ (mΩ/m)	0.043	0.040	0.038	0.029	0.021	0.019	0.017	0.013	0.009	
Protective conductor resistance	$R_{PE}$ (mΩ/m)	0.119	0.112	0.109	0.098	0.078	0.091	0.091	0.084	0.075	
Protective conductor reactance	$X_{PE}$ (mΩ/m)	0.130	0.130	0.130	0.130	0.130	0.110	0.110	0.110	0.110	
Phase-PE fault loop resistance	$R_0$ (mΩ/m)	0.161	0.152	0.147	0.126	0.099	0.110	0.108	0.096	0.084	
Phase-PE fault loop reactance (50 Hz)	$X_0$ (mΩ/m)	0.227	0.206	0.204	0.204	0.170	0.141	0.141	0.136	0.133	
Phase-neutral fault loop resistance	$R_0$ (mΩ/m)	0.074	0.069	0.066	0.050	0.037	0.047	0.041	0.031	0.022	
Phase-neutral fault loop reactance (50 Hz)	$X_0$ (mΩ/m)	0.227	0.206	0.204	0.204	0.170	0.172	0.172	0.162	0.156	
Voltage drop with uniformly distributed loads $u = K \cdot L \cdot I_e \cdot 10^{-6}$ (V)	K (V/m/A)10 <sup>-6</sup>	$\cos\phi = 0.70$	85.5	71.1	68.9	63.1	37.5	30.7	29.3	23.6	19.6
		$\cos\phi = 0.75$	83.3	69.3	67.2	60.9	36.6	30.2	26.6	23.0	18.9
		$\cos\phi = 0.80$	80.0	67.0	64.9	58.3	35.4	29.3	27.7	22.2	18.0
		$\cos\phi = 0.85$	75.7	63.9	61.8	54.8	33.7	28.2	26.4	21.0	16.9
		$\cos\phi = 0.90$	68.9	59.6	57.6	50.2	31.5	26.6	24.7	18.6	15.6
		$\cos\phi = 0.95$	61.4	53.2	51.4	43.5	28.2	24.0	22.1	17.3	13.4
		$\cos\phi = 1.00$	37.0	34.4	33.0	24.7	18.2	16.5	14.5	10.8	7.6
Weight	(kg/m)	34.2	36.4	37.7	46.5	60.3	59.0	64.6	81.0	108.2	
Calorific power with regard to fire	(kWh/m)	4.1	4.1	4.1	4.1	4.1	6.6	6.6	6.6	6.6	
Degree of protection (IEC EN 60529)	IP	30-31	30-31	30-31	30-31	30-31	30-31	30-31	30-31	30-31	
Losses through Joule effect at rated current	P (W/m)	128	186	293	343	395	515	513	601	660	

Meets standards: IEC 60439-1 and 60439-2 [change to IEC 61439-6, see p. 74], DIN VDE 0660 parts 500 and 502  
Product can be used in a damp atmosphere (IEC 60068-2-3, IEC 60068-2-30)

In: rated current for an ambient temperature of 40°C  
For use at a different ambient temperature, see p. 50

Contact Legrand for the characteristics of other versions

# Prefabricated busbar trunking (continued)

## 2 SCP TRUNKING

### 2.1 Applications

Trunking is used for transporting and distributing high power and is well suited to vertical networks (rising mains). It can be used in both industrial premises and in commercial buildings (factories, banks, shopping and business centres, etc.).



The compact dimensions of SCP trunking allow it to be installed, even in confined spaces.

### 2.2 General characteristics

- Compact profile providing better resistance to short-circuit stresses and control of impedance and voltage drops.
- Two versions available depending on the nature of the conductor bars:
  - electrolytic copper ETP 99.9 UNI EN 13601;
  - aluminium alloy treated over its entire surface with galvanic processes (copper plating + tinning).

- Rated current of 630 to 4,000A with aluminium conductors and 800 to 5,000A with copper conductors (the rated currents are given for an average ambient temperature of 40°C).
- Enclosure made of hot galvanised riveted steel profiles, 1.5mm thick (2mm thickness or stainless steel upon request).
- RAL 7035 resin paint (other colours upon request) with a high resistance to chemical agents.
- Degree of protection IP 55. By using the protective shroud available as an accessory, it is possible to use SCP trunking outdoors.
- Isolation of the bars using double sleeving in class B (130°C) polyester film – class F (155°C) upon request.
- Protective conductor (PE) provided by the enclosure. Versions with a heavy-duty protective conductor, made of copper or aluminium, are available upon request.
- Version with an additional conductor for a functional earth (3P+N+PE+FE)
- Size of neutral cross section: 100% (3P+N+PE) or 200% of the cross section of the phases (3P+2N+PE).
- Electrical connection between the items by single-piece connectors fitted with predetermined torque shear-head bolts.
- V1 self-extinguishing capability to standard UL94 and compatibility with the glow-wire test to standard EN 60695-2-1 for all components made of insulating material.

The wide washers on the single-piece connector boxes ensure the distribution of contact pressure and that it is maintained.



## 2.3 Composition of the system

Legrand offers a wide variety of technical solutions to meet all installation needs.



The variety of SCP components allows for any change of direction.

### > Transport sections

All items connect to each other with single-piece connectors. Straight sections are delivered with a pre-fitted single-piece connector.

- Straight sections without a tap-off outlet, standard length 3m (from 1 to 3m made to measure).
- Straight sections with tap-off outlets every 850mm on both sides of the trunking to receive junction boxes.
- 90° horizontal and vertical elbows.
- T, X, and Z sections (double elbows with all possible direction combinations).

### > Special sections

- Straight sections with an S120 fire-break barrier for passing through fire-break partitions (see p. 43).
- Straight sections with expansion compensation, to be inserted in long runs, every 35-40m, to compensate for the thermal expansion of the building or the trunking.

- Straight sections with phase rotation or neutral rotation. These sections are useful for changing the position of the phases or the position of the neutral. They allow balancing of the mutual reactance of the phases to be reduced and therefore the balancing of currents for trunking in excess of 100 to 150m.
- Closure caps to provide the IP 55 degree of protection at the end of the trunking.

### > Connection interfaces

The spreaders and feed units are fitted at the end of the trunking and allow the system to be connected to enclosures or transformers. Connection plates allow cables fitted with lugs to be connected or connection via bars. The standard spacing between the connection plates is 100mm. It is possible to obtain configurations with different spacing upon request.

## + Connection kits for XL<sup>3</sup> enclosures

SCP trunking can be easily connected to Legrand XL<sup>3</sup> 4 000 enclosures. A reinforcing kit allows all types of spreader to be quickly and simply fixed on the roof of the enclosure. Upon request, special connections can be supplied to make the connection between the spreader and a DMX<sup>3</sup> ACB.

The system's safety and efficacy are guaranteed by certification obtained following rigorous testing conducted in major international laboratories.



# Pre-fabricated busbar trunking (continued)

## > Junction cabinets

Junction cabinets are available for SCP trunking up to 1,250A. There are two types: plug-in cabinets and fixed cabinets.

- Plug-in cabinets (from 63 to 630A)
  - they can be connected and disconnected when live, so long as they are not under load
  - they are fitted with a built-in cut-off on the door
  - the door can be locked out using a padlock in the “open-disconnected” position to ensure that maintenance operations are carried out in safety
  - the protective conductor is the first one connected when the cabinet is inserted into the trunking and the last one disconnected when it is unplugged
  - all insulating components pass the glow-wire test in IEC 60695-2-10 and are classed V1 in accordance with standard UL94
  - the IP 55 degree of protection is guaranteed without using any additional accessory
  - cabinets are available in the following versions:
    - with fuse holders
    - with isolating switch and fuse holders
    - with DPX<sup>3</sup> or DPX circuit breaker.
- Fixed cabinets bolted on to the trunking (125 to 1,250A)
  - rigid connection by using a single-piece connector identical to the other sections
  - installation and dismantling of the cabinet only when the trunking is not live
  - versions available with isolating switch and fuse holders or with DPX<sup>3</sup> or DPX circuit breaker.

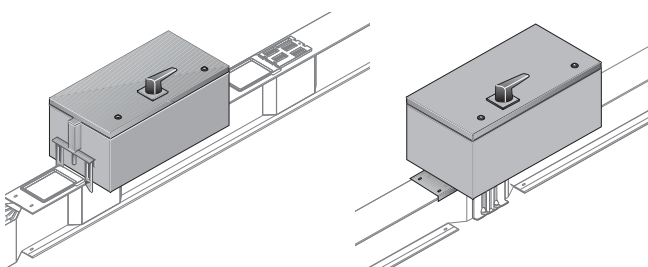

Plug-in box: mounting on a tap-off outlet

Bolted box: fitting at the junction of straight sections

## > Protective bellows and flexible braids

These allow trunking to be isolated from equipment that generates vibrations (transformers, generators, etc.).

Legrand dry transformers have connection kits specially designed for use with SCP trunking.

## > Fixing accessories

- Fixing flanges for installing all types of supports: suspensions, brackets, beams, etc.
- Special suspension brackets for rising mains.

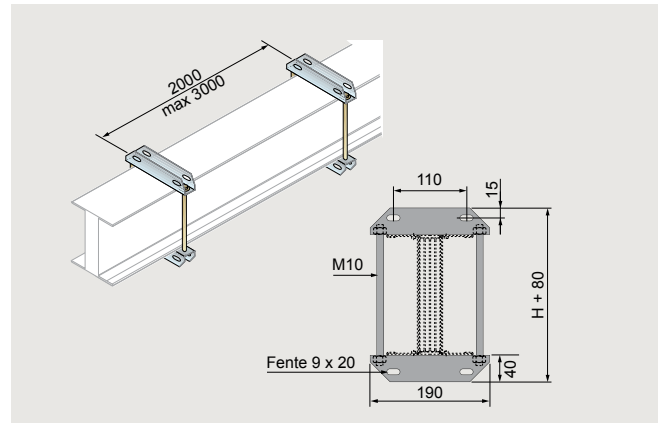

Fixing flange for angled sections

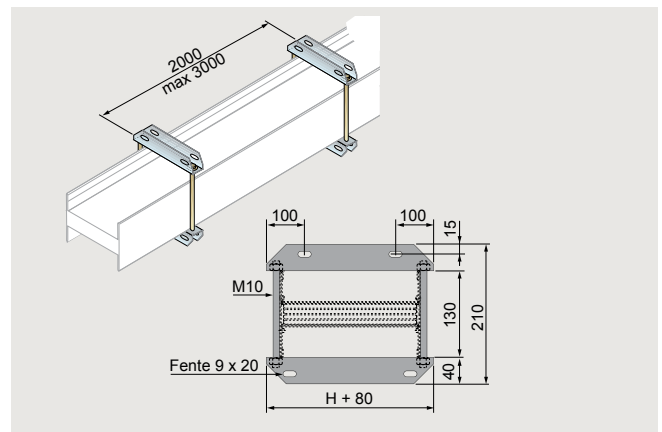

Fixing flange for flat sections



## Rising mains

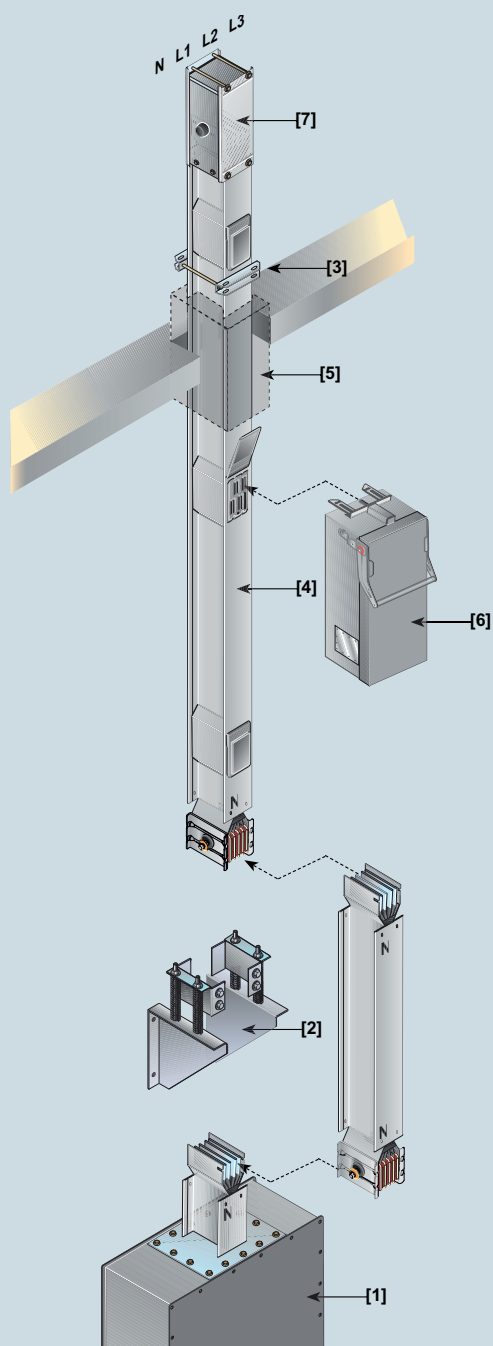

High and medium power trunking can be used in a rising main to provide vertical energy distribution in buildings.

To produce a rising main using SCP trunking, a few simple rules must be followed.

**1** – Use a feed box without a single piece connector. To position junction boxes correctly, the neutral conductor must be on the left hand side of the part.

**2** – Use one or more suspension supports for vertical sections depending on the total weight of the rising main. For rising mains longer than 4m, use a support with springs for each 300kg section (including the weight of the boxes).

**3** – Use standard fixing flanges for hanging the trunking every 2 metres.

**4** – Use straight sections with tap-off outlets.

**5** – Use an S120 fire-break barrier at each point where a separating floor crosses.

**6** – Junction boxes may be installed on tap-off outlets at the junctions between sections. In both cases, boxes are oriented downwards

**7** – Install an IP 55 closure at the end of the rising main.

# Pre-fabricated busbar trunking (continued)

## 2.4 Technical characteristics

Aluminium SCP trunking (3P + N + PE)										
Rated current	I <sub>n</sub> (A)	Single bars						Double bars		
		630	800	1000	1,250	1,600	2,000	2,500	3,200	4,000
External dimensions	L x H (mm)	130 x 130	130 x 130	130 x 130	130 x 130	130 x 170	130 x 220	130 x 380	130 x 440	130 x 480
Operating voltage	U <sub>e</sub> (V)	1000	1000	1000	1000	1000	1000	1000	1000	1000
Isolation voltage	U <sub>i</sub> (V)	1000	1000	1000	1000	1000	1000	1000	1000	1000
Operating frequency	f (Hz)	50/60	50/60	50/60	50/60	50/60	50/60	50/60	50/60	50/60
Permissible short-duration current in a 3-phase fault (1s)	I <sub>CW</sub> (kA)rms	36	42	50	75	80	80	150	160	160
Peak current permissible in a 3-phase fault	I <sub>pk</sub> (kA)	76	88	110	165	176	176	330	352	352
Short-duration current permissible in a fault on 1 phase (1s)	I <sub>CW</sub> (kA)rms	22	25	30	45	48	48	90	96	96
Peak current permissible in a fault on 1 phase	I <sub>pk</sub> (kA)	48	55	66	99	106	106	198	211	211
Permissible thermal stress in a 3-phase fault	I <sup>2</sup> t [MA <sup>2</sup> s]	1,296	1,764	2,500	5,625	6,400	6,400	22,500	25,600	25,600
Phase resistance	R <sub>20</sub> (mΩ/m)	0.077	0.058	0.058	0.047	0.035	0.027	0.022	0.017	0.014
Phase reactance (50Hz)	X (mΩ/m)	0.023	0.017	0.017	0.015	0.014	0.011	0.006	0.006	0.006
Phase impedance	Z (mΩ/m)	0.080	0.060	0.060	0.049	0.037	0.029	0.022	0.018	0.015
Phase resistance at thermal equilibrium	R <sub>t</sub> (mΩ/m)	0.084	0.064	0.069	0.056	0.041	0.032	0.025	0.020	0.017
Phase impedance at thermal equilibrium	Z (mΩ/m)	0.087	0.066	0.071	0.058	0.043	0.034	0.026	0.021	0.018
Neutral resistance	R <sub>20</sub> (mΩ/m)	0.077	0.058	0.058	0.047	0.035	0.027	0.022	0.017	0.014
Protective conductor resistance (PE 1)	R <sub>PE</sub> (mΩ/m)	0.125	0.125	0.125	0.125	0.113	0.101	0.075	0.069	0.065
Protective conductor resistance (PE 2)	R <sub>PE</sub> (mΩ/m)	0.036	0.036	0.036	0.036	0.028	0.023	0.014	0.012	0.011
Protective conductor resistance (PE 3)	R <sub>PE</sub> (mΩ/m)	0.050	0.050	0.050	0.050	0.041	0.033	0.021	0.018	0.017
Protective conductor reactance (50 Hz)	X <sub>PE</sub> (mΩ/m)	0.080	0.078	0.078	0.048	0.039	0.028	0.020	0.015	0.016
Fault loop resistance (PE 1)	R <sub>o</sub> (mΩ/m)	0.209	0.189	0.194	0.181	0.154	0.133	0.100	0.089	0.082
Fault loop resistance (PE 2)	R <sub>o</sub> (mΩ/m)	0.120	0.100	0.105	0.092	0.069	0.055	0.039	0.032	0.028
Fault loop resistance (PE 3)	R <sub>o</sub> (mΩ/m)	0.134	0.114	0.119	0.106	0.082	0.065	0.046	0.038	0.034
Fault loop reactance (50 Hz)	X <sub>o</sub> (mΩ/m)	0.10	0.10	0.10	0.06	0.05	0.04	0.03	0.02	0.02
Fault loop impedance (PE 1)	Z <sub>o</sub> (mΩ/m)	0.233	0.212	0.216	0.192	0.163	0.139	0.103	0.092	0.085
Fault loop impedance (PE 2)	Z <sub>o</sub> (mΩ/m)	0.158	0.138	0.142	0.112	0.087	0.068	0.047	0.038	0.036
Fault loop impedance (PE 3)	Z <sub>o</sub> (mΩ/m)	0.169	0.149	0.152	0.123	0.098	0.076	0.053	0.044	0.041
Phase homopolar resistance - N	R <sub>o</sub> (mΩ/m)	0.306	0.257	0.257	0.238	0.172	0.140	0.107	0.080	0.070
Phase homopolar reactance - N	X <sub>o</sub> (mΩ/m)	0.174	0.160	0.160	0.128	0.106	0.108	0.083	0.073	0.060
Phase homopolar impedance - N	Z <sub>o</sub> (mΩ/m)	0.352	0.303	0.303	0.270	0.202	0.177	0.135	0.108	0.092
Phase homopolar resistance - PE	R <sub>o</sub> (mΩ/m)	0.581	0.519	0.519	0.369	0.321	0.270	0.217	0.196	0.164
Phase homopolar reactance - PE	X <sub>o</sub> (mΩ/m)	0.263	0.229	0.229	0.191	0.175	0.212	0.155	0.148	0.146
Phase homopolar impedance - PE	Z <sub>o</sub> (mΩ/m)	0.638	0.567	0.567	0.416	0.366	0.343	0.267	0.246	0.22
Voltage drop with uniformly distributed loads u = K · L · I <sub>B</sub> · 10 <sup>-4</sup> (V)	cosφ = 0.70	65.1	49.5	52.5	43.3	33.6	26.3	18.8	15.9	14.2
	cosφ = 0.75	67.7	51.5	54.7	45.1	34.7	27.2	19.6	16.5	14.6
	cosφ = 0.80	70.1	53.3	56.8	46.7	35.7	28.0	20.4	17.1	15.1
	cosφ = 0.85	72.3	55.1	58.7	48.2	36.6	28.7	21.1	17.6	15.4
	cosφ = 0.90	74.1	56.5	60.4	49.4	37.3	29.2	21.7	18.0	15.7
	cosφ = 0.95	75.3	57.5	61.6	50.3	37.6	29.4	22.1	18.2	15.8
cosφ = 1.00	72.7	55.6	60.0	48.6	35.6	27.8	21.6	17.4	14.9	
Weight (PE 1)	p (kg/m)	17.3	17.0	17.0	18.7	20.3	30.7	43.7	52.3	62.7
Weight (PE 2)	p (kg/m)	20.8	20.5	20.5	23.2	24.9	36.7	53.9	64.3	75.7
Weight (PE 3)	p (kg/m)	18.4	18.1	18.1	20.8	21.8	32.6	46.9	56.1	66.8
Calorific power with regard to fire	(kWh/m)	4.5	5.5	5.5	6.0	8.5	10.5	16.0	19.0	21.0
Degree of protection (IEC EN 60529)	IP	55	55	55	55	55	55	55	55	55
Thermal resistance class for insulating materials	B/F*	B/F*	B/F*	B/F*	B/F*	B/F*	B/F*	B/F*	B/F*	B/F*
Losses through Joule effect at rated current	P (W/m)	100	123	208	263	315	386	468	618	827
Min/max ambient temperature	(°C)	-5/50	-5/50	-5/50	-5/50	-5/50	-5/50	-5/50	-5/50	-5/50

\* Class F (155°C) available on request



PE 1



PE 2



PE 3

Standard version    Reinforced copper earth    Reinforced aluminium earth

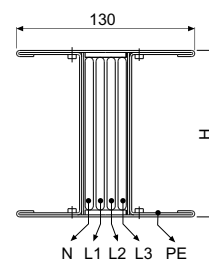

### Copper SCP trunking (3P + N + PE)

Rated current	$I_n$ (A)	Single bars						Double bars			
		800	1000	1,250	1,600	2,000	2,500	3,200	4,000	5,000	
External dimensions	L x H (mm)	130 x 130	130 x 130	130 x 130	130 x 170	130 x 170	130 x 220	130 x 380	130 x 440	130 x 480	
Operating voltage	$U_e$ (V)	1000	1000	1000	1000	1000	1000	1000	1000	1000	
Isolation voltage	$U_i$ (V)	1000	1000	1000	1000	1000	1000	1000	1000	1000	
Operating frequency	f (Hz)	50/60	50/60	50/60	50/60	50/60	50/60	50/60	50/60	50/60	
Permissible short-duration current in a 3-phase fault (1s)	$I_{CW}$ (kA)rms	45	50	60	85	88	88	170	176	176	
Peak current permissible in a 3-phase fault	$I_{pk}$ (kA)	95	110	132	187	194	194	374	387	387	
Short-duration current permissible in a fault on 1 phase (1s)	$I_{CW}$ (kA)rms	27	30	36	51	53	53	102	106	106	
Peak current permissible in a fault on 1 phase	$I_{pk}$ (kA)	57	66	79	112	116	116	224	232	232	
Permissible thermal stress in a 3-phase fault	$I^2t$ (MA <sup>2</sup> s)	2,025	2,500	3,600	7,225	7,744	7,744	28,900	30,976	30,976	
Phase resistance	$R_{20}$ (mΩ/m)	0.041	0.032	0.032	0.024	0.020	0.016	0.012	0.010	0.008	
Phase reactance (50Hz)	X (mΩ/m)	0.023	0.017	0.017	0.015	0.014	0.011	0.007	0.006	0.006	
Phase impedance	Z (mΩ/m)	0.047	0.037	0.037	0.028	0.024	0.019	0.014	0.012	0.010	
Phase resistance at thermal equilibrium	$R_t$ (mΩ/m)	0.045	0.037	0.040	0.029	0.024	0.019	0.015	0.013	0.010	
Phase impedance at thermal equilibrium	$R_{20}$ (mΩ/m)	0.023	0.017	0.017	0.015	0.014	0.011	0.007	0.006	0.006	
Neutral resistance	Z (mΩ/m)	0.050	0.041	0.043	0.033	0.028	0.022	0.016	0.014	0.012	
Protective conductor resistance (PE 1)	$R_{PE}$ (mΩ/m)	0.125	0.125	0.125	0.113	0.113	0.101	0.075	0.069	0.065	
Protective conductor resistance (PE 2)	$R_{PE}$ (mΩ/m)	0.036	0.036	0.036	0.028	0.028	0.023	0.014	0.012	0.011	
Protective conductor resistance (PE 3)	$R_{PE}$ (mΩ/m)	0.050	0.050	0.050	0.041	0.041	0.033	0.021	0.018	0.017	
Protective conductor reactance (50 Hz)	$X_{PE}$ (mΩ/m)	0.054	0.054	0.054	0.044	0.044	0.032	0.022	0.017	0.016	
Fault loop resistance (PE 1)	$R_o$ (mΩ/m)	0.170	0.162	0.165	0.142	0.137	0.120	0.090	0.082	0.075	
Fault loop resistance (PE 2)	$R_o$ (mΩ/m)	0.081	0.073	0.076	0.057	0.052	0.042	0.029	0.025	0.021	
Fault loop resistance (PE 3)	$R_o$ (mΩ/m)	0.095	0.087	0.090	0.070	0.065	0.052	0.036	0.031	0.027	
Fault loop reactance (50 Hz)	$X_o$ (mΩ/m)	0.077	0.071	0.071	0.059	0.058	0.043	0.029	0.023	0.022	
Fault loop impedance (PE 1)	$Z_o$ (mΩ/m)	0.186	0.177	0.179	0.154	0.149	0.128	0.094	0.085	0.078	
Fault loop impedance (PE 2)	$Z_o$ (mΩ/m)	0.111	0.102	0.104	0.082	0.078	0.060	0.041	0.034	0.030	
Fault loop impedance (PE 3)	$Z_o$ (mΩ/m)	0.122	0.112	0.114	0.092	0.087	0.068	0.046	0.039	0.035	
Phase homopolar resistance - N	$R_o$ (mΩ/m)	0.170	0.155	0.155	0.115	0.120	0.098	0.083	0.071	0.062	
Phase homopolar reactance - N	$X_o$ (mΩ/m)	0.159	0.151	0.151	0.114	0.098	0.065	0.056	0.055	0.042	
Phase homopolar impedance - N	$Z_o$ (mΩ/m)	0.233	0.216	0.216	0.162	0.155	0.118	0.100	0.090	0.075	
Phase homopolar resistance - PE	$R_o$ (mΩ/m)	0.507	0.429	0.429	0.331	0.283	0.221	0.177	0.178	0.144	
Phase homopolar reactance - PE	$X_o$ (mΩ/m)	0.201	0.177	0.177	0.143	0.150	0.124	0.111	0.094	0.086	
Phase homopolar impedance - PE	$Z_o$ (mΩ/m)	0.545	0.464	0.464	0.361	0.320	0.253	0.209	0.201	0.168	
Voltage drop with uniformly distributed loads $u = K \cdot L \cdot I_B \cdot 10^{-4}$ (V)	K (V/m/A)10 <sup>-6</sup>	$\cos\phi = 0.70$	41.3	33.0	34.6	27.1	23.5	18.5	13.2	11.5	9.8
		$\cos\phi = 0.75$	42.1	33.8	35.5	27.7	23.9	18.8	13.5	11.8	9.9
		$\cos\phi = 0.80$	42.8	34.5	36.3	28.1	24.2	19.1	13.8	12.1	10.0
		$\cos\phi = 0.85$	43.3	35.0	37.0	28.4	24.4	19.2	14.0	12.2	10.1
		$\cos\phi = 0.90$	43.4	35.3	37.3	28.5	24.4	19.2	14.1	12.3	10.1
		$\cos\phi = 0.95$	42.9	35.1	37.2	28.2	23.9	18.8	14.0	12.2	9.8
		$\cos\phi = 1.00$	38.6	32.1	34.4	25.4	21.2	16.7	12.7	11.2	8.7
Weight (PE 1)	p (kg/m)	31	31	31	42	46	69	84	101	126	
Weight (PE 2)	p (kg/m)	35	35	35	47	51	70	94	114	139	
Weight (PE 3)	p (kg/m)	33	32	32	44	48	66	87	105	130	
Calorific power with regard to fire	(kWh/m)	4.5	5.5	5.5	8	8.2	10.5	16	19	21	
Degree of protection (IEC EN 60529)	IP	55	55	55	55	55	55	55	55	55	
Thermal resistance class for insulating materials		B/F*	B/F*	B/F*	B/F*	B/F*	B/F*	B/F*	B/F*	B/F*	
Losses through Joule effect at rated current	P (W/m)	86	111	186	225	294	361	451	619	750	
Min/max ambient temperature	(°C)	-5/50	-5/50	-5/50	-5/50	-5/50	-5/50	-5/50	-5/50	-5/50	

\* Class F (155°C) available on request



PE 1



PE 2



PE 3

Standard version Reinforced copper earth Reinforced aluminium earth

# Pre-fabricated busbar trunking (continued)

## Aluminium SCP trunking (3P + N + PE + FE)

Rated current	In (A)	Single bars						Double bars		
		630	800	1000	1,250	1,600	2,000	2,500	3,200	4,000
External dimensions	L x H (mm)	140 x 130	140 x 130	140 x 130	140 x 130	140 x 170	140 x 220	140 x 380	140 x 440	140 x 480
Operating voltage	U <sub>e</sub> (V)	1000	1000	1000	1000	1000	1000	1000	1000	1000
Isolation voltage	U <sub>i</sub> (V)	1000	1000	1000	1000	1000	1000	1000	1000	1000
Operating frequency	f (Hz)	50/60	50/60	50/60	50/60	50/60	50/60	50/60	50/60	50/60
Permissible short-duration current in a 3-phase fault (1s)	I <sub>CW</sub> (kA)rms	36	42	50	75	80	80	150	160	160
Peak current permissible in a 3-phase fault	I <sub>pk</sub> (kA)	76	88	110	165	176	176	330	352	352
Short-duration current permissible in a fault on 1 phase (1s)	I <sub>CW</sub> (kA)rms	22	25	30	45	48	48	90	96	96
Peak current permissible in a fault on 1 phase	I <sub>pk</sub> (kA)	48	55	66	99	106	106	198	211	211
Permissible thermal stress in a 3-phase fault	I <sup>2</sup> t (MA <sup>2</sup> s)	1,296	1,764	2,500	5,625	6,400	6,400	22,500	25,600	25,600
Phase resistance	R <sub>20</sub> (mΩ/m)	0.077	0.058	0.058	0.047	0.035	0.027	0.022	0.017	0.014
Phase reactance (50 Hz)	X (mΩ/m)	0.023	0.017	0.017	0.015	0.014	0.011	0.006	0.006	0.006
Phase impedance	Z (mΩ/m)	0.080	0.060	0.060	0.049	0.037	0.029	0.022	0.018	0.015
Phase resistance at thermal equilibrium	R <sub>t</sub> (mΩ/m)	0.084	0.064	0.069	0.056	0.041	0.032	0.025	0.020	0.017
Phase impedance at thermal equilibrium	Z (mΩ/m)	0.087	0.066	0.071	0.058	0.043	0.034	0.026	0.021	0.018
Neutral resistance	R <sub>20</sub> (mΩ/m)	0.077	0.058	0.058	0.047	0.035	0.027	0.022	0.017	0.014
Functional earth resistance (FE)	R <sub>20</sub> (mΩ/m)	0.077	0.058	0.058	0.047	0.035	0.027	0.022	0.017	0.014
Functional earth reactance (FE)	X (mΩ/m)	0.023	0.017	0.017	0.015	0.014	0.011	0.006	0.006	0.006
Protective conductor resistance (PE 1)	R <sub>PE</sub> (mΩ/m)	0.121	0.121	0.121	0.121	0.110	0.098	0.074	0.068	0.064
Protective conductor resistance (PE 2)	R <sub>PE</sub> (mΩ/m)	0.035	0.035	0.035	0.035	0.028	0.023	0.014	0.012	0.011
Protective conductor resistance (PE 3)	R <sub>PE</sub> (mΩ/m)	0.050	0.050	0.050	0.050	0.040	0.033	0.020	0.018	0.017
Protective conductor reactance (50 Hz)	X <sub>PE</sub> (mΩ/m)	0.080	0.078	0.078	0.048	0.039	0.028	0.020	0.015	0.016
Fault loop resistance (PE 1)	R <sub>o</sub> (mΩ/m)	0.131	0.103	0.108	0.090	0.067	0.053	0.042	0.034	0.028
Fault loop resistance (PE 2)	R <sub>o</sub> (mΩ/m)	0.108	0.086	0.091	0.076	0.057	0.044	0.033	0.027	0.023
Fault loop resistance (PE 3)	R <sub>o</sub> (mΩ/m)	0.114	0.091	0.096	0.080	0.060	0.047	0.035	0.029	0.025
Fault loop reactance (50Hz)	X <sub>o</sub> (mΩ/m)	0.10	0.10	0.10	0.06	0.05	0.04	0.03	0.02	0.02
Fault loop impedance (PE 1)	Z <sub>o</sub> (mΩ/m)	0.167	0.140	0.144	0.110	0.086	0.066	0.049	0.040	0.036
Fault loop impedance (PE 2)	Z <sub>o</sub> (mΩ/m)	0.149	0.128	0.132	0.099	0.078	0.059	0.042	0.034	0.032
Fault loop impedance (PE 3)	Z <sub>o</sub> (mΩ/m)	0.154	0.132	0.135	0.102	0.080	0.061	0.044	0.036	0.033
Phase homopolar resistance - N	R <sub>o</sub> (mΩ/m)	0.306	0.257	0.257	0.238	0.172	0.140	0.107	0.080	0.070
Phase homopolar reactance - N	X <sub>o</sub> (mΩ/m)	0.174	0.160	0.160	0.128	0.106	0.108	0.083	0.073	0.060
Phase homopolar impedance - N	Z <sub>o</sub> (mΩ/m)	0.352	0.303	0.303	0.270	0.202	0.177	0.135	0.108	0.092
Phase homopolar resistance - PE	R <sub>o</sub> (mΩ/m)	0.468	0.387	0.387	0.246	0.213	0.173	0.113	0.107	0.070
Phase homopolar reactance - PE	X <sub>o</sub> (mΩ/m)	0.263	0.229	0.229	0.191	0.175	0.212	0.155	0.148	0.146
Phase homopolar impedance - PE	Z <sub>o</sub> (mΩ/m)	0.537	0.450	0.450	0.311	0.276	0.274	0.192	0.183	0.162
Voltage drop with uniformly distributed loads u = K · L · I <sub>B</sub> · 10 <sup>-6</sup> (V)	cosφ = 0.70	65.1	49.5	52.5	43.3	33.6	26.3	18.8	15.9	14.2
	cosφ = 0.75	67.7	51.5	54.7	45.1	34.7	27.2	19.6	16.5	14.6
	cosφ = 0.80	70.1	53.3	56.8	46.7	35.7	28.0	20.4	17.1	15.1
	cosφ = 0.85	72.3	55.1	58.7	48.2	36.6	28.7	21.1	17.6	15.4
	cosφ = 0.90	74.1	56.5	60.4	49.4	37.3	29.2	21.7	18.0	15.7
	cosφ = 0.95	75.3	57.5	61.6	50.3	37.6	29.4	22.1	18.2	15.8
	cosφ = 1.00	72.7	55.6	60.0	48.6	35.6	27.8	21.6	17.4	14.9
Weight (PE 1)	p (kg/m)	21.6	21.3	21.3	23.4	25.4	38.4	54.6	65.4	78.4
Weight (PE 2)	p (kg/m)	23.0	22.8	22.8	26.4	28.6	41.4	60.1	72.1	84.9
Weight (PE 3)	p (kg/m)	20.6	20.4	20.4	24.0	25.5	37.4	53.1	64.0	76.0
Calorific power with regard to fire	(kWh/m)	5.6	6.9	6.9	7.5	10.6	13.1	20.0	23.8	26.3
Degree of protection (IEC EN 60529)	IP	55	55	55	55	55	55	55	55	55
Thermal resistance class for insulating materials	B/F*	B/F*	B/F*	B/F*	B/F*	B/F*	B/F*	B/F*	B/F*	B/F*
Losses through Joule effect at rated current	P (W/m)	100	123	208	263	315	386	468	618	827
Min/max ambient temperature	(°C)	-5/50	-5/50	-5/50	-5/50	-5/50	-5/50	-5/50	-5/50	-5/50

\* Class F (155°C) available on request



PE 1

Standard version



PE 2

Reinforced copper earth



PE 3

Reinforced aluminium earth

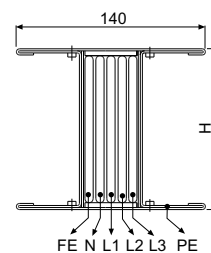

### Copper SCP trunking (3P + N + PE + FE)

Rated current	$I_n$ (A)	Single bars						Double bars		
		800	1000	1,250	1,600	2,000	2,500	3,200	4,000	5,000
External dimensions	L x H (mm)	140 x 130	140 x 130	140 x 130	140 x 170	140 x 170	140 x 220	140 x 380	140 x 480	130 x 480
Operating voltage	$U_e$ (V)	1000	1000	1000	1000	1000	1000	1000	1000	1000
Isolation voltage	$U_i$ (V)	1000	1000	1000	1000	1000	1000	1000	1000	1000
Operating frequency	f (Hz)	50/60	50/60	50/60	50/60	50/60	50/60	50/60	50/60	50/60
Permissible short-duration current in a 3-phase fault (1s)	$I_{CW}$ (kA)rms	45	50	60	85	88	88	170	176	176
Peak current permissible in a 3-phase fault	$I_{pk}$ (kA)	95	110	132	187	194	194	374	387	387
Short-duration current permissible in a fault on 1 phase (1s)	$I_{CW}$ (kA)rms	27	30	36	51	53	53	102	106	106
Peak current permissible in a fault on 1 phase	$I_{pk}$ (kA)	57	66	79	112	116	116	224	232	232
Permissible thermal stress in a 3-phase fault	$I^2t$ (MA <sup>2</sup> s)	2,025	2,500	3,600	7,225	7,744	7,744	28,900	30,976	30,976
Phase resistance	$R_{20}$ (mΩ/m)	0.041	0.032	0.032	0.024	0.020	0.016	0.012	0.010	0.008
Phase reactance [50 Hz]	X (mΩ/m)	0.023	0.017	0.017	0.015	0.014	0.011	0.007	0.006	0.006
Phase impedance	Z (mΩ/m)	0.047	0.037	0.037	0.028	0.024	0.019	0.014	0.012	0.010
Phase resistance at thermal equilibrium	$R_t$ (mΩ/m)	0.045	0.037	0.040	0.029	0.024	0.019	0.015	0.013	0.010
Phase impedance at thermal equilibrium	$R_{20}$ (mΩ/m)	0.023	0.017	0.017	0.015	0.014	0.011	0.007	0.006	0.006
Neutral resistance	Z (mΩ/m)	0.041	0.032	0.032	0.024	0.020	0.016	0.012	0.010	0.008
Functional earth resistance (FE)	$R_{20}$ (mΩ/m)	0.041	0.032	0.032	0.024	0.020	0.016	0.012	0.010	0.008
Functional earth reactance (FE)	X (mΩ/m)	0.023	0.017	0.017	0.015	0.014	0.011	0.007	0.006	0.006
Protective conductor resistance (PE 1)	$R_{PE}$ (mΩ/m)	0.125	0.125	0.125	0.113	0.113	0.101	0.075	0.069	0.065
Protective conductor resistance (PE 2)	$R_{PE}$ (mΩ/m)	0.036	0.036	0.036	0.028	0.028	0.023	0.014	0.012	0.011
Protective conductor resistance (PE 3)	$R_{PE}$ (mΩ/m)	0.050	0.050	0.050	0.041	0.041	0.033	0.021	0.018	0.017
Protective conductor reactance (50Hz)	$X_{PE}$ (mΩ/m)	0.054	0.054	0.054	0.044	0.044	0.032	0.022	0.017	0.016
Fault loop resistance (PE 1)	$R_o$ (mΩ/m)	0.170	0.162	0.165	0.142	0.137	0.120	0.090	0.082	0.075
Fault loop resistance (PE 2)	$R_o$ (mΩ/m)	0.081	0.073	0.076	0.057	0.052	0.042	0.029	0.025	0.021
Fault loop resistance (PE 3)	$R_o$ (mΩ/m)	0.095	0.087	0.090	0.070	0.065	0.052	0.036	0.031	0.027
Fault loop reactance (50Hz)	$X_o$ (mΩ/m)	0.077	0.071	0.071	0.059	0.058	0.043	0.029	0.023	0.022
Fault loop impedance (PE 1)	$Z_o$ (mΩ/m)	0.186	0.177	0.179	0.154	0.149	0.128	0.094	0.085	0.078
Fault loop impedance (PE 2)	$Z_o$ (mΩ/m)	0.111	0.102	0.104	0.082	0.078	0.060	0.041	0.034	0.030
Fault loop impedance (PE 3)	$Z_o$ (mΩ/m)	0.122	0.112	0.114	0.092	0.087	0.068	0.046	0.039	0.035
Phase homopolar resistance - N	$R_o$ (mΩ/m)	0.170	0.155	0.155	0.115	0.120	0.098	0.083	0.071	0.062
Phase homopolar reactance - N	$X_o$ (mΩ/m)	0.159	0.151	0.151	0.114	0.098	0.065	0.056	0.055	0.042
Phase homopolar impedance - N	$Z_o$ (mΩ/m)	0.233	0.216	0.216	0.162	0.155	0.118	0.100	0.090	0.075
Phase homopolar resistance - PE	$R_o$ (mΩ/m)	0.507	0.429	0.429	0.331	0.283	0.221	0.177	0.178	0.144
Phase homopolar reactance - PE	$X_o$ (mΩ/m)	0.201	0.177	0.177	0.143	0.150	0.124	0.111	0.094	0.086
Phase homopolar impedance - PE	$Z_o$ (mΩ/m)	0.545	0.464	0.464	0.361	0.320	0.253	0.209	0.201	0.168
Voltage drop with uniformly distributed loads $u = K \cdot L \cdot I_B \cdot 10^{-6}$ (V)	$\cos\phi = 0.70$	41.3	33.0	34.6	27.1	23.5	18.5	13.2	11.5	9.8
	$\cos\phi = 0.75$	42.1	33.8	35.5	27.7	23.9	18.8	13.5	11.8	9.9
	$\cos\phi = 0.80$	42.8	34.5	36.3	28.1	24.2	19.1	13.8	12.1	10.0
	$\cos\phi = 0.85$	43.3	35.0	37.0	28.4	24.4	19.2	14.0	12.2	10.1
	$\cos\phi = 0.90$	43.4	35.3	37.3	28.5	24.4	19.2	14.1	12.3	10.1
	$\cos\phi = 0.95$	42.9	35.1	37.2	28.2	23.9	18.8	14.0	12.2	9.8
$\cos\phi = 1.00$	38.6	32.1	34.4	25.4	21.2	16.7	12.7	11.2	8.7	
Weight (PE 1)	$\rho$ (kg/m)	31	31	31	42	46	69	84	101	126
Weight (PE 2)	$\rho$ (kg/m)	35	35	35	47	51	70	94	114	139
Weight (PE 3)	$\rho$ (kg/m)	33	32	32	44	48	66	87	105	130
Calorific power with regard to fire	(kWh/m)	5.6	6.9	6.9	7.5	10.6	13.1	20.0	23.8	26.3
Degree of protection (IEC EN 60529)	IP	55	55	55	55	55	55	55	55	55
Thermal resistance class for insulating materials		B/F*	B/F*	B/F*	B/F*	B/F*	B/F*	B/F*	B/F*	B/F*
Losses through Joule effect at rated current	P (W/m)	86	111	186	225	294	361	451	619	750
Min/max ambient temperature	(°C)	-5/50	-5/50	-5/50	-5/50	-5/50	-5/50	-5/50	-5/50	-5/50

\* Class F (155°C) available on request



PE 1

Standard version



PE 2

Reinforced copper earth



PE 3

Reinforced aluminium earth

# Pre-fabricated busbar trunking (continued)

“Double neutral aluminium SCP trunking (3P + 2N + PE)”

Rated current	In (A)	Single bars						Double bars		
		630	800	1000	1,250	1,600	2,000	2,500	3,200	4,000
External dimensions	L x H (mm)	140 x 130	140 x 130	140 x 130	140 x 130	140 x 170	140 x 220	140 x 380	140 x 440	140 x 480
Operating voltage	U <sub>e</sub> (V)	1000	1000	1000	1000	1000	1000	1000	1000	1000
Isolation voltage	U <sub>i</sub> (V)	1000	1000	1000	1000	1000	1000	1000	1000	1000
Operating frequency	f (Hz)	50/60	50/60	50/60	50/60	50/60	50/60	50/60	50/60	50/60
Permissible short-duration current in a 3-phase fault (1s)	I <sub>CW</sub> (kA)rms	36	42	50	75	80	80	150	160	160
Peak current permissible in a 3-phase fault	I <sub>pk</sub> (kA)	76	88	110	165	176	176	330	352	352
Short-duration current permissible in a fault on 1 phase (1s)	I <sub>CW</sub> (kA)rms	22	25	30	45	48	48	90	96	96
Peak current permissible in a fault on 1 phase	I <sub>pk</sub> (kA)	48	55	66	99	106	106	198	211	211
Permissible short-duration protection current (1s)	I <sub>CW</sub> (kA)rms	22	25	30	45	48	48	90	96	96
Permissible peak current for the protection circuit	I <sub>pk</sub> (kA)	48	55	66	99	106	106	198	211	211
Permissible thermal stress in a 3-phase fault	I <sup>2</sup> t (MA <sup>2</sup> s)	1,296	1,764	2,500	5,625	6,400	6,400	22,500	25,600	25,600
Phase resistance	R <sub>20</sub> (mΩ/m)	0.077	0.058	0.058	0.047	0.035	0.027	0.022	0.017	0.014
Phase reactance (50Hz)	X (mΩ/m)	0.023	0.017	0.017	0.015	0.014	0.011	0.006	0.006	0.006
Phase impedance	Z (mΩ/m)	0.080	0.060	0.060	0.049	0.037	0.029	0.022	0.018	0.015
Phase resistance at thermal equilibrium	R <sub>t</sub> (mΩ/m)	0.084	0.064	0.069	0.056	0.041	0.032	0.025	0.020	0.017
Phase impedance at thermal equilibrium	Z (mΩ/m)	0.087	0.066	0.071	0.058	0.043	0.034	0.026	0.021	0.018
Neutral resistance	R <sub>20</sub> (mΩ/m)	0.038	0.029	0.029	0.023	0.017	0.013	0.011	0.008	0.007
Protective conductor resistance (PE 1)	R <sub>PE</sub> (mΩ/m)	0.121	0.121	0.121	0.121	0.110	0.098	0.074	0.068	0.064
Protective conductor resistance (PE 2)	R <sub>PE</sub> (mΩ/m)	0.035	0.035	0.035	0.035	0.028	0.023	0.014	0.012	0.011
Protective conductor resistance (PE 3)	R <sub>PE</sub> (mΩ/m)	0.050	0.050	0.050	0.050	0.040	0.033	0.020	0.018	0.017
Protective conductor reactance (50 Hz)	X <sub>PE</sub> (mΩ/m)	0.080	0.078	0.078	0.048	0.039	0.028	0.020	0.015	0.016
Fault loop resistance (PE 1)	R <sub>o</sub> (mΩ/m)	0.205	0.185	0.190	0.177	0.151	0.130	0.099	0.088	0.081
Fault loop resistance (PE 2)	R <sub>o</sub> (mΩ/m)	0.119	0.099	0.104	0.091	0.069	0.055	0.039	0.032	0.028
Fault loop resistance (PE 3)	R <sub>o</sub> (mΩ/m)	0.134	0.114	0.119	0.106	0.081	0.065	0.045	0.038	0.034
Fault loop reactance (50 Hz)	X <sub>o</sub> (mΩ/m)	0.10	0.10	0.10	0.06	0.05	0.04	0.03	0.02	0.02
Fault loop impedance (PE 1)	Z <sub>o</sub> (mΩ/m)	0.229	0.208	0.213	0.188	0.160	0.136	0.102	0.091	0.084
Fault loop impedance (PE 2)	Z <sub>o</sub> (mΩ/m)	0.157	0.137	0.141	0.111	0.087	0.068	0.047	0.038	0.036
Fault loop impedance (PE 3)	Z <sub>o</sub> (mΩ/m)	0.169	0.149	0.152	0.123	0.097	0.076	0.052	0.044	0.041
Phase homopolar resistance - N	R <sub>o</sub> (mΩ/m)	0.147	0.135	0.135	0.132	0.129	0.126	0.084	0.063	0.048
Phase homopolar reactance - N	X <sub>o</sub> (mΩ/m)	0.198	0.180	0.180	0.166	0.160	0.190	0.135	0.165	0.103
Phase homopolar impedance - N	Z <sub>o</sub> (mΩ/m)	0.247	0.225	0.225	0.212	0.206	0.228	0.159	0.177	0.114
Phase homopolar resistance - PE	R <sub>o</sub> (mΩ/m)	0.581	0.519	0.519	0.369	0.321	0.270	0.217	0.196	0.164
Phase homopolar reactance - PE	X <sub>o</sub> (mΩ/m)	0.263	0.229	0.229	0.191	0.175	0.212	0.155	0.148	0.146
Phase homopolar impedance - PE	Z <sub>o</sub> (mΩ/m)	0.638	0.567	0.567	0.416	0.366	0.343	0.267	0.246	0.220
Voltage drop with uniformly distributed loads u = K · L · I <sub>B</sub> · 10 <sup>-6</sup> (V)	cos φ = 0.70	65.1	49.5	52.5	43.3	33.6	26.3	18.8	15.9	14.2
	cos φ = 0.75	67.7	51.5	54.7	45.1	34.7	27.2	19.6	16.5	14.6
	cos φ = 0.80	70.1	53.3	56.8	46.7	35.7	28.0	20.4	17.1	15.1
	cos φ = 0.85	72.3	55.1	58.7	48.2	36.6	28.7	21.1	17.6	15.4
	cos φ = 0.90	74.1	56.5	60.4	49.4	37.3	29.2	21.7	18.0	15.7
	cos φ = 0.95	75.3	57.5	61.6	50.3	37.6	29.4	22.1	18.2	15.8
cos φ = 1.00	72.7	55.6	60.0	48.6	35.6	27.8	21.6	17.4	14.9	
Weight (PE 1)	p (kg/m)	21.6	21.3	21.3	23.4	25.4	38.4	54.6	65.4	78.4
Weight (PE 2)	p (kg/m)	23.0	22.8	22.8	26.4	28.6	41.4	60.1	72.1	84.9
Weight (PE 3)	p (kg/m)	20.6	20.4	20.4	24.0	25.5	37.4	53.1	64.0	76.0
Calorific power with regard to fire	(kWh/m)	5.6	6.9	6.9	7.5	10.6	13.1	20.0	23.8	26.3
Degree of protection (IEC EN 60529)	IP	55	55	55	55	55	55	55	55	55
Thermal resistance class for insulating materials	B/F*	B/F*	B/F*	B/F*	B/F*	B/F*	B/F*	B/F*	B/F*	B/F*
Thermal losses through Joule effect at rated current	P (W/m)	100	123	208	263	315	386	468	618	827
Min/max ambient temperature	(°C)	-5/50	-5/50	-5/50	-5/50	-5/50	-5/50	-5/50	-5/50	-5/50

\* Class F (155°C) available on request



PE 1



PE 2



PE 3

Standard version    Reinforced copper earth    Reinforced aluminium earth

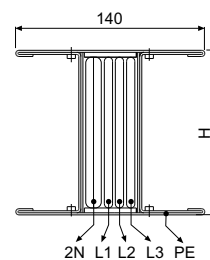

## “Double neutral” copper SCP trunking (3P + 2N + PE)

Rated current	I <sub>n</sub> (A)	Single bars						Double bars			
		800	1000	1,250	1,600	2,000	2,500	3,200	4,000	5,000	
External dimensions	L x H (mm)	140 x 130	140 x 130	140 x 130	140 x 170	140 x 170	140 x 220	140 x 380	140 x 440	140 x 480	
Operating voltage	U <sub>e</sub> (V)	1000	1000	1000	1000	1000	1000	1000	1000	1000	
Isolation voltage	U <sub>i</sub> (V)	1000	1000	1000	1000	1000	1000	1000	1000	1000	
Operating frequency	f (Hz)	50/60	50/60	50/60	50/60	50/60	50/60	50/60	50/60	50/60	
Permissible short-duration current in a 3-phase fault (1s)	I <sub>CW</sub> (kA)rms	45	50	60	85	88	88	170	176	176	
Peak current permissible in a 3-phase fault	I <sub>pk</sub> (kA)	95	110	132	187	194	194	374	387	387	
Short-duration current permissible in a fault on 1 phase (1s)	I <sub>CW</sub> (kA)rms	27	30	36	51	53	53	102	106	106	
Peak current permissible in a fault on 1 phase	I <sub>pk</sub> (kA)	57	66	79	112	116	116	224	232	232	
Permissible short-duration protection current (1 s)	I <sub>CW</sub> (kA)rms	27	30	36	51	53	53	102	106	106	
Permissible peak current for the protection circuit	I <sub>pk</sub> (kA)	57	66	79	112	116	116	224	232	232	
Permissible thermal stress in a 3-phase fault	I <sup>2</sup> t (MA <sup>2</sup> s)	2,025	2,500	3,600	7,225	7,744	7,744	28,900	30,976	30,976	
Phase resistance	R <sub>20</sub> (mΩ/m)	0.041	0.032	0.032	0.024	0.020	0.016	0.012	0.010	0.008	
Phase reactance (50 Hz)	X (mΩ/m)	0.023	0.017	0.017	0.015	0.014	0.011	0.007	0.006	0.006	
Phase impedance	Z (mΩ/m)	0.0471	0.0365	0.0365	0.0284	0.0244	0.019	0.0143	0.012	0.0101	
Phase resistance at thermal equilibrium	R <sub>t</sub> (mΩ/m)	0.0446	0.037	0.0397	0.0293	0.0245	0.0192	0.0147	0.0129	0.01	
Phase impedance at thermal equilibrium	Z (mΩ/m)	0.023	0.017	0.017	0.015	0.014	0.011	0.007	0.006	0.006	
Neutral resistance	R <sub>20</sub> (mΩ/m)	0.0205	0.0162	0.0162	0.012	0.01	0.0078	0.0062	0.0052	0.0041	
Protective conductor resistance (PE 1)	R <sub>PE</sub> (mΩ/m)	0.125	0.125	0.125	0.113	0.113	0.101	0.075	0.069	0.065	
Protective conductor resistance (PE 2)	R <sub>PE</sub> (mΩ/m)	0.036	0.036	0.036	0.028	0.028	0.023	0.014	0.012	0.011	
Protective conductor resistance (PE 3)	R <sub>PE</sub> (mΩ/m)	0.05	0.05	0.05	0.041	0.041	0.033	0.021	0.018	0.017	
Protective conductor reactance (50 Hz)	X <sub>PE</sub> (mΩ/m)	0.054	0.054	0.054	0.044	0.044	0.032	0.022	0.017	0.016	
Fault loop resistance (PE 1)	R <sub>0</sub> (mΩ/m)	0.170	0.162	0.1647	0.1423	0.1375	0.1202	0.0897	0.0819	0.075	
Fault loop resistance (PE 2)	R <sub>0</sub> (mΩ/m)	0.081	0.073	0.0757	0.0573	0.0525	0.0422	0.0287	0.0249	0.021	
Fault loop resistance (PE 3)	R <sub>0</sub> (mΩ/m)	0.946	0.087	0.0897	0.0703	0.0655	0.0522	0.0357	0.0309	0.027	
Fault loop reactance (50Hz)	X <sub>0</sub> (mΩ/m)	0.077	0.071	0.071	0.059	0.058	0.043	0.029	0.023	0.022	
Fault loop impedance (PE 1)	Z <sub>0</sub> (mΩ/m)	0.186	0.177	0.179	0.154	0.149	0.128	0.094	0.085	0.078	
Fault loop impedance (PE 2)	Z <sub>0</sub> (mΩ/m)	0.111	0.102	0.104	0.082	0.078	0.060	0.041	0.034	0.030	
Fault loop impedance (PE 3)	Z <sub>0</sub> (mΩ/m)	0.122	0.112	0.114	0.092	0.087	0.068	0.046	0.039	0.035	
Phase homopolar resistance - N	R <sub>0</sub> (mΩ/m)	0.128	0.125	0.125	0.121	0.117	0.094	0.088	0.065	0.046	
Phase homopolar reactance - N	X <sub>0</sub> (mΩ/m)	0.184	0.152	0.152	0.143	0.127	0.122	0.078	0.076	0.073	
Phase homopolar impedance - N	Z <sub>0</sub> (mΩ/m)	0.2241	0.1968	0.1968	0.1873	0.1727	0.154	0.1176	0.100	0.0863	
Phase homopolar resistance - PE	R <sub>0</sub> (mΩ/m)	0.507	0.429	0.429	0.331	0.283	0.221	0.177	0.178	0.144	
Phase homopolar reactance - PE	X <sub>0</sub> (mΩ/m)	0.201	0.177	0.177	0.143	0.15	0.124	0.111	0.094	0.086	
Phase homopolar impedance - PE	Z <sub>0</sub> (mΩ/m)	0.545	0.4641	0.4641	0.3606	0.3203	0.2534	0.2089	0.2013	0.1677	
Voltage drop with uniformly distributed loads u = K · L · I <sub>B</sub> · 10 <sup>-4</sup> (V)	K (V/m/A)10 <sup>-6</sup>	cosφ = 0.70	41.3	33.0	34.6	27.1	23.5	18.5	13.2	11.5	9.8
		cosφ = 0.75	42.1	33.8	35.5	27.7	23.9	18.8	13.5	11.8	9.9
		cosφ = 0.80	42.8	34.5	36.3	28.1	24.2	19.1	13.8	12.1	10.0
		cosφ = 0.85	43.3	35.0	37.0	28.4	24.4	19.2	14.0	12.2	10.1
		cosφ = 0.90	43.4	35.3	37.3	28.5	24.4	19.2	14.1	12.3	10.1
		cosφ = 0.95	42.9	35.1	37.2	28.2	23.9	18.8	14.0	12.2	9.8
cosφ = 1.00	38.6	32.1	34.4	25.4	21.2	16.7	12.7	11.2	8.7		
Weight (PE 1)	p (kg/m)	39	39	39	53	58	86	105	126	158	
Weight (PE 2)	p (kg/m)	41	41	41	55	60	83	111	134	165	
Weight (PE 3)	p (kg/m)	38	38	38	52	57	79	104	126	157	
Calorific power with regard to fire	(kWh/m)	5.6	6.9	6.9	10.0	10.3	13.1	20.0	23.8	26.3	
Degree of protection (IEC EN 60529)	IP	55	55	55	55	55	55	55	55	55	
Thermal resistance class for insulating materials		B/F*	B/F*	B/F*	B/F*	B/F*	B/F*	B/F*	B/F*	B/F*	
Thermal losses through Joule effect at rated current	P (W/m)	86	111	186	225	294	361	451	619	750	
Min/max ambient temperature	(°C)	-5/50	-5/50	-5/50	-5/50	-5/50	-5/50	-5/50	-5/50	-5/50	

\* Class F (155°C) available on request



PE 1

Standard version



PE 2

Reinforced copper earth



PE 3

Reinforced aluminium earth

# Prefabricated busbar trunking (continued)

## MEDIUM POWER TRUNKING

Legrand offers three ranges of medium-power trunking:

- **MR**: ideal for horizontal distribution or in a rising main in office and industrial buildings.
- **MS**: more suited to small and medium industrial sites for the supply of workshops and machines.
- **TS**: specially designed for supplying mobile equipment (travelling cranes, assembly lines, etc.)

### 1 MR TRUNKING

#### 1.1 Applications

These trunking ranges are used for transporting and distributing medium power. They are suitable for horizontal or vertical (rising mains) distribution. They can be used in both industrial premises and office buildings (factories, banks, shopping and business centres).

#### 1.2 General characteristics

- Speed, flexibility and simplicity, in both design and implementation.
- Two versions available depending on the type of conductor bars:
  - 99.9% pure electrolytic copper;
  - aluminium alloy treated over its entire surface with galvanic processes (copper plating + tinning).
- Rated current of 160 to 1,000A with aluminium conductors and 250 to 1,000A with copper conductors (the rated currents are given for an average ambient temperature of 40°C).
- Conformity with IEC 60439-1 and 60439-2.
- Hot-galvanised steel enclosure providing electrical continuity (RAL paint upon request).
- Degree of protection:
  - with installed window blanking plates: IP 55
  - without blanking plates: IP 52
  - flat trunking: IP 40.
- Holding and spacing of the bars by insulating glass-fibre reinforced resin insulating supports.

- Number of conductors (identical cross-sections): 4 (3P + N) or 5 for version MRf (3P + N + PE).
- Protective conductor (PE) function provided by the galvanised steel enclosure.
- Electrical connection between the single-piece connectors fitted with pre-determined torque shear-head bolts.
- Fire behaviour meets IEC 60332-3 and halogen-free insulating materials.

#### 1.3 Composition of the system

The MR range is a complete system meeting all energy transport and distribution needs up to 1,000 A.

##### > Transport sections

All sections are connected to each other using pre-installed single-piece connectors.



90° elbow with single-piece connector

- Straight elements without a tap-off outlet (standard 3m length).
- Straight sections (3m length) with tap-off outlets every 1 m on both sides of the trunking or every 0.5 m on a single face.
- Custom straight sections (from 0.6 to 3m) with or without tap-off outlet.
- 90° horizontal and vertical elbows, standard or custom dimensions.
- Tees, crossovers, double elbows with all possible orientation combinations.
- Closure caps to provide the IP55 degree of protection at the end of the trunking.

### > Feed and spreader units

They allow the trunking to be supplied by cables or directly from a transformer. Intermediate boxes can supply the trunking at any point.



End feed unit

### > Tap-off boxes

The MR range offers a wide choice of tap-off boxes, with DIN rail to be equipped, pre-equipped with fuse carriers, pre-equipped and pre-wired with 3P+N sockets, with an isolation device on the lid. There are two types:

- P63 to 630A plug-in boxes. They are fitted to the tap-off outlets and can be connected or disconnected live.

- Fixed boxes bolted on to the trunking (630 to 1,000A). They use the single-piece connection between the sections. They can only be fitted and dismantled while the trunking is switched off.



Plug-in tap-off box

### > Fixing accessories

- Suspension clamps enabling installation with any type of support: hangers for fixing to the ceiling, spacers, adjustable arms for wall fixing, supports with clips for fixing to girders, etc.
- Special suspension supports for rising mains.



Supports should be provided every 2 metres

# Prefabricated busbar trunking (continued)

## 1.4 Technical characteristics

### MR 4 trunking with aluminium conductors

		160	250	315	400	500	630	800
Rated current at 40°C	$I_n$ (A)	160	250	315	400	500	630	800
Operating voltage	$U_e$ (V)	1,000	1,000	1,000	1,000	1,000	1,000	1,000
Isolation voltage	$U_i$ (V)	1,000	1,000	1,000	1,000	1,000	1,000	1,000
Operating frequency	$f$ (Hz)	50/60	50/60	50/60	50/60	50/60	50/60	50/60
Permissible short-term current in a 3-phase fault (1s)	$I_{CW}$ (kA) <sub>rms</sub>	15*	25*	25*	25	30	36	36
Permissible thermal stress in a 3-phase fault	$I^2t$ (MA <sup>2</sup> s)	23	63	63	625	900	1,296	1,296
Peak current permissible in a 3-phase fault	$I_{pk}$ (kA)	30	53	53	53	63	76	76
Short duration current permissible in a phase-N fault (1s)	$I_{CW}$ (kA) <sub>rms</sub>	9*	15*	15*	15	18	22	22
Peak current permissible in a phase-N fault	$I_{pk}$ (kA)	15	30	30	30	36	45	45
Short duration current permissible in a phase-PE fault (1s)	$I_{CW}$ (kA) <sub>rms</sub>	9*	15*	15*	15	18	22	22
Peak current permissible in a phase-PE fault	$I_{pk}$ (kA)	15	30	30	30	36	45	45
Phase resistance at 20°C	$R_{20}$ (mΩ/m)	0.492	0.328	0.197	0.120	0.077	0.060	0.052
Phase resistance at thermal equilibrium (40°C)	$R_t$ (mΩ/m)	0.665	0.443	0.266	0.163	0.104	0.081	0.070
Phase reactance (50Hz)	$X$ (mΩ/m)	0.260	0.202	0.186	0.130	0.110	0.097	0.096
Neutral resistance at 20°C	$R_{N20}$ (mΩ/m)	0.492	0.328	0.197	0.120	0.077	0.060	0.052
Neutral reactance (50Hz)	$X_n$ (mΩ/m)	0.260	0.202	0.186	0.130	0.110	0.097	0.096
Protective conductor resistance	$R_{PE}$ (mΩ/m)	0.341	0.341	0.341	0.283	0.283	0.283	0.283
Protective conductor reactance (50Hz)	$X_{PE}$ (mΩ/m)	0.220	0.220	0.220	0.180	0.180	0.180	0.180
Phase-PE fault loop resistance	RPh-Pe fault loop (mΩ/m)	1.006	0.784	0.607	0.445	0.387	0.364	0.353
Phase-PE fault loop reactance (50Hz)	XRPh-Pe fault loop (mΩ/m)	0.480	0.414	0.396	0.333	0.333	0.283	0.275
Phase-neutral fault loop resistance	RPh-N fault loop (mΩ/m)	1.157	0.771	0.463	0.283	0.181	0.141	0.121
Phase-neutral fault loop reactance (50Hz)	XRPh-N fault loop (mΩ/m)	0.480	0.422	0.406	0.310	0.290	0.277	0.276
Linear voltage drop with uniformly distributed loads (K) (see p. 49)	$(V/m/A)10^{-3} \cos\phi = 0.70$	0.564	0.394	0.276	0.179	0.131	0.109	0.102
	$(V/m/A)10^{-3} \cos\phi = 0.75$	0.581	0.404	0.279	0.180	0.130	0.108	0.100
	$(V/m/A)10^{-3} \cos\phi = 0.80$	0.596	0.412	0.281	0.180	0.129	0.107	0.098
	$(V/m/A)10^{-3} \cos\phi = 0.85$	0.608	0.418	0.281	0.179	0.127	0.104	0.095
	$(V/m/A)10^{-3} \cos\phi = 0.90$	0.616	0.422	0.277	0.176	0.122	0.100	0.091
	$(V/m/A)10^{-3} \cos\phi = 0.95$	0.617	0.419	0.269	0.169	0.115	0.093	0.083
	$(V/m/A)10^{-3} \cos\phi = 1.00$	0.576	0.384	0.230	0.141	0.090	0.070	0.060
Losses through Joule effect at rated current	$L$ (W/m)	51	83	79	78	78	97	134
Calorific power with regard to fire	(kWh/m)	1.3	1.3	1.3	1.8	1.8	1.8	1.8
Weight	$w$ (kg/m)	7.4	7.7	8.4	10.7	12.3	13.8	14.7
External dimensions	$L \times H$ (mm)	76 x 195	76 x 195	76 x 195	136 x 195	136 x 195	136 x 195	136 x 195
Degree of protection	IP	52-55	52-55	52-55	52-55	52-55	52-55	52-55
Mechanical strength of the enclosure	IK	10	10	10	10	10	10	10

\* Values for 0.1s

$I_n$ : rated current for an ambient temperature of 40°C  
For use at a different ambient temperature, see p. 50

Meets standards: IEC 60439-1 and 2 (change to IEC 61439-6, see pp. 74),  
DIN VDE 0660 parts 500 and 502  
Product suitable for use in a damp atmosphere (IEC 60068-2-3,  
IEC 60068-2-30)

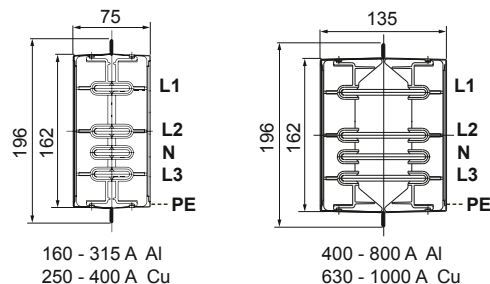

### MR trunking with four copper conductors

Rated current at 40°C	$I_n$ (A)	250	315	400	630	800	1,000
Operating voltage	$U_e$ (V)	1,000	1,000	1,000	1,000	1,000	1,000
Isolation voltage	$U_i$ (V)	1,000	1,000	1,000	1,000	1,000	1,000
Operating frequency	$f$ (Hz)	50/60	50/60	50/60	50/60	50/60	50/60
Permissible short-term current in a 3-phase fault (1s)	$I_{CW}$ (kA) <sub>rms</sub>	25*	25*	30*	36	36	36
Permissible thermal stress in a 3-phase fault	$I^2t$ (MA <sup>2</sup> s)	63	63	90	1,296	1,296	1,296
Peak current permissible in a 3-phase fault	$I_{pk}$ (kA)	53	53	63	76	76	76
Short-term current permissible in a phase-N fault (1s)	$I_{CW}$ (kA) <sub>rms</sub>	15*	15*	18*	22	22	22
Peak current permissible in a phase-N fault	$I_{pk}$ (kA)	30	30	36	45	45	45
Short-term current permissible in a phase-PE fault (1s)	$I_{CW}$ (kA) <sub>rms</sub>	15*	15*	18*	22	22	22
Peak current permissible in a phase-PE fault	$I_{pk}$ (kA)	30	30	36	45	45	45
Phase resistance at 20°C	$R_{20}$ (mΩ/m)	0.237	0.180	0.096	0.061	0.040	0.032
Phase resistance at thermal equilibrium (40°C)	$R_t$ (mΩ/m)	0.320	0.243	0.129	0.082	0.053	0.043
Phase reactance (50Hz)	$X$ (mΩ/m)	0.205	0.188	0.129	0.122	0.122	0.120
Neutral resistance at 20°C	$R_{N20}$ (mΩ/m)	0.237	0.180	0.096	0.061	0.040	0.032
Neutral reactance (50Hz)	$X_n$ (mΩ/m)	0.205	0.188	0.129	0.122	0.122	0.120
Protective conductor resistance	$R_{PE}$ (mΩ/m)	0.336	0.336	0.336	0.279	0.279	0.279
Protective conductor reactance (50Hz)	$X_{PE}$ (mΩ/m)	0.220	0.220	0.220	0.180	0.180	0.180
Phase-PE fault loop resistance	RPh-Pe fault loop (mΩ/m)	0.657	0.579	0.466	0.361	0.332	0.322
Phase-PE fault loop reactance (50Hz)	XRPh-Pe fault loop (mΩ/m)	0.425	0.408	0.349	0.302	0.302	0.300
Phase-neutral fault loop resistance	RPh-N fault loop (mΩ/m)	0.558	0.423	0.225	0.143	0.093	0.074
Phase-neutral fault loop reactance (50Hz)	XRPh-N fault loop (mΩ/m)	0.425	0.408	0.349	0.302	0.302	0.300
Linear voltage drop with uniformly distributed loads (K) (see pp. 49)	$(V/m/A)10^{-3} \cos\phi = 0.70$	0.321	0.263	0.158	0.125	0.108	0.100
	$(V/m/A)10^{-3} \cos\phi = 0.75$	0.326	0.265	0.158	0.123	0.105	0.096
	$(V/m/A)10^{-3} \cos\phi = 0.80$	0.329	0.266	0.157	0.120	0.100	0.092
	$(V/m/A)10^{-3} \cos\phi = 0.85$	0.329	0.264	0.154	0.116	0.095	0.086
	$(V/m/A)10^{-3} \cos\phi = 0.90$	0.327	0.260	0.149	0.110	0.088	0.079
	$(V/m/A)10^{-3} \cos\phi = 0.95$	0.319	0.251	0.141	0.101	0.077	0.068
	$(V/m/A)10^{-3} \cos\phi = 1.00$	0.277	0.210	0.112	0.071	0.046	0.037
Losses through Joule effect at rated current	$L$ (W/m)	60	72	62	98	103	128
Calorific power with regard to fire	(kWh/m)	1.3	1.3	1.3	1.8	1.8	1.8
Weight	$w$ (kg/m)	9.3	10.2	13.3	18.2	23.9	27.9
External dimensions	$L \times H$ (mm)	76 x 195	76 x 195	76 x 195	136 x 195	136 x 195	136 x 195
Degree of protection	IP	52-55	52-55	52-55	52-55	52-55	52-55
Mechanical strength of the enclosure	IK	10	10	10	10	10	10

\* Values for 0.1s

$I_n$ : rated current for an ambient temperature of 40°C  
For use at a different ambient temperature, see p. 50

Meets standards: IEC 60439-1 and 2 (change to IEC 61439-6, see pp. 74),  
DIN VDE 0660 parts 500 and 502  
Product suitable for use in a damp atmosphere (IEC 60068-2-3,  
IEC 60068-2-30)

# Prefabricated busbar trunking (continued)

## 2 MS TRUNKING

### 2.1 Applications

This trunking is used to distribute medium-range power. It is ideal for supplying machines in a workshop, for example.

### 2.2 General characteristics

- Speed, flexibility and simplicity, both in design and in the implementation of the system.
- Very robust construction with reduced dimensions (39 x 97 mm).
- Rated current: 63, 100 and 160A at 40°C.
- Conformity with IEC 60439-1 and 60439-2.
- Hot-galvanised steel enclosure providing electrical continuity.
- Degree of protection IP40. IP55 can easily be obtained by adding junction covers and window blanking plates.
- Bars held in place and spaced using glass-fibre reinforced resin insulated support, classed V1 (to UL94) and passing the glow-wire test in accordance with IEC 60695-2-10.
- Protective earth conductor (PE) provided by the steel casing (electrical continuity ensured with no additional accessory).
- Number of conductors: 4 (3P + N) with the same section.
- Mechanical and electrical connection between the sections in a single operation.
- Single-piece connectors with copper contacts covered with silver for the automatic connection of two active conductors and the PE conductor.

### 2.3 Composition of the system

The MS system offers all the elements necessary for producing a complete energy distribution installation up to 160A.

#### > Transport sections

All sections are connected to each other using pre-installed single-piece connectors.

- Standard straight sections (lengths 1m, 1.5m, 2m and 3m) with tap-off windows every metre on either side of the trunking.
- Custom straight element without tap-off window.
- Flexible joints allowing changes of direction at any angle, horizontally or vertically.

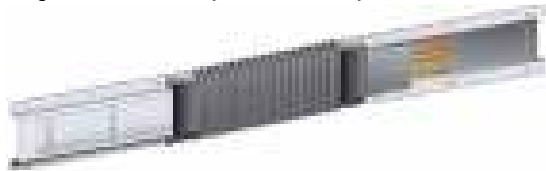

Flexible joint

#### > Feed units

These allow the trunking to be supplied from one end or from the middle. Supply cables are connected to cage terminals.

#### > Tap-off boxes

The MS range offers a large range of tap-off boxes from 16 to 63A: with DIN rail to be equipped, pre-equipped with fuse carriers, with disconnection device on the lid... They are installed in tap-off outlets and can be connected and disconnected live.

#### > Accessories

- Window blanking plates, junction lids, end caps to ensure an IP55 degree of protection
- Fixing clamps to attach the trunking to the building structure, either directly, or using supports (brackets, hangers, etc.).

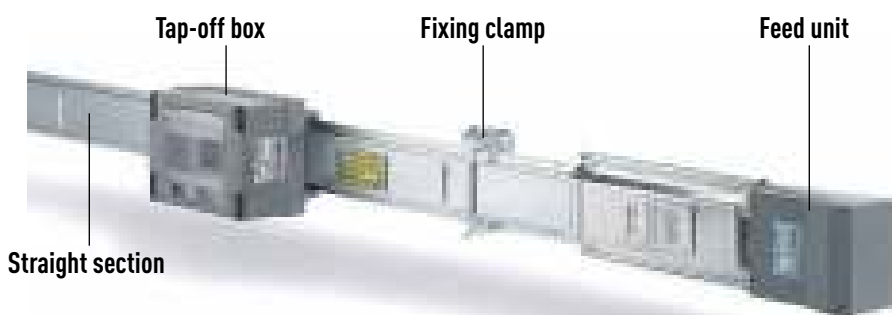

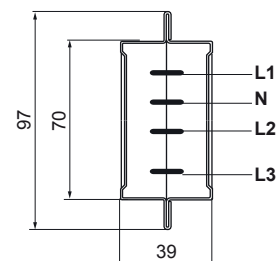

## 2.4 Technical characteristics

MS trunking (3P+N)				
Model		63	100	160
Number of active conductors	No.	4	4	4
External dimensions	L x H (mm)	39 x 97	39 x 97	39 x 97
Rated current at 40°C	$I_n$ (A)	63	100	160
Conductor cross-section (3P+N)	S (mm <sup>2</sup> )	26	39	39
PE protective conductor cross-section (eq. Cu)	$S_{PE}$ (mm <sup>2</sup> )	21	21	21
Operating voltage	$U_e$ (V)	400	400	400
Isolation voltage	$U_i$ (V)	750	750	750
Operating frequency	f (Hz)	50/60	50/60	50/60
Short duration permissible current (0.1 sec)	$I_{CW}$ (kA)rms	2.30	4.50	5.50
Permissible peak current	$I_{pk}$ (kA)	10	10	10
Permissible thermal stress	$I^2t$ (A <sup>2</sup> s x 10 <sup>6</sup> )	5.29	20.25	30.25
Phase resistance	$R_{20}$ (mΩ/m)	1.250	0.837	0.478
Phase reactance (50Hz)	X (mΩ/m)	0.366	0.247	0.247
Phase impedance	Z (mΩ/m)	1.302	0.873	0.538
Protective conductor resistance	$R_{PE}$ (mΩ/m)	0.857	0.857	0.857
Protective conductor reactance (50Hz)	$X_{PE}$ (mΩ/m)	0.090	0.102	0.102
Fault loop resistance	$R_o$ (mΩ/m)	2.11	1.69	1.34
Fault loop reactance (50Hz)	$X_o$ (mΩ/m)	0.456	0.349	0.349
Fault loop impedance	$Z_o$ (mΩ/m)	2.16	1.73	1.38
Linear voltage drop with uniformly distributed loads (K) (see pp. 49)	$[V/m/A]10^{-3} \cos\varphi = 0.70$	0.98	0.66	0.44
	$[V/m/A]10^{-3} \cos\varphi = 0.75$	1.02	0.69	0.45
	$[V/m/A]10^{-3} \cos\varphi = 0.80$	1.06	0.71	0.46
	$[V/m/A]10^{-3} \cos\varphi = 0.85$	1.09	0.73	0.46
	$[V/m/A]10^{-3} \cos\varphi = 0.90$	1.11	0.75	0.47
	$[V/m/A]10^{-3} \cos\varphi = 0.95$	1.13	0.76	0.46
	$[V/m/A]10^{-3} \cos\varphi = 1.00$	1.08	0.72	0.41
Weight of a straight section	w (kg/m)	2.0	2.5	2.8
Calorific power with regard to fire	(kWh/m)	1.64	1.64	1.64
Degree of protection	IP	40/55	40/55	40/55
Losses through Joule effect at rated current	L (W/m)	14.9	25.1	36.7
Min/max ambient temperature	t (°C)	-5/+50	-5/+50	-5/+50

$I_n$ : rated current for an ambient temperature of 40°C  
 For use at a different ambient temperature, see p. 50  
 Meets standards: IEC 60439-1 and 60439-1 and 2 (change to IEC 61439-6, see p. 74), DIN VDE 0660 parts 500 and 502  
 "Fire retardant" meets standard IEC 20-22 (IEC 332-3: 1992).  
 Product suitable for use in a damp atmosphere (IEC 60068-2-3, IEC 60068-2-30)

# Prefabricated busbar trunking (continued)

## 3 TS TRUNKING

### 3.1 Applications

This trunking is intended for supplying mobile equipment such as: travelling cranes, transverse engines, assembly lines, etc.

### 3.2 General characteristics

- Supply to the equipment provided by trolleys which can move freely along trunking while it is live.
- Rated current: 63, 70, 110, 150 and 250A at 40 °C.
- Allows straight and curved horizontal movements to be made (up to 150A).
- Conforms to standard IEC 60439-1 and 2
- Aluminium (TS 63A) or hot-galvanised steel enclosure.
- Degree of protection IP23 (TS 63A) or IP20.
- Bars held in place and spaced using GRP insulated supports, classed V1 (to UL94) and passing the glow-wire test in accordance with IEC 60695-2-10.
- Number of conductors: 5 for TS trunking up to 150A (3P + N + PE), 4 for the TS 250A (3P + PE) – 3-phase motor supply
- Electrical tap-off system providing the quick and reliable connection of active conductors and the protective conductor.

### 1.3 Composition of the system

#### > Transport elements

- Straight sections (length 1.5 and 3 m).
- Straight sections with trolley insertion device (length 3 m).
- Straight sections with expansion joint to be installed every 35 to 40m (length 3m).
- Curved sections with a curve radius of 1.5 m (length 3m). Special curve radii, greater than 1.5 m, can be made to order.

#### > Feed units

These allow trunking to be supplied by cables. The TS range offers central and end-mounting feed units.

#### > Coupling sections

These provide a mechanical connection to the electrical tap-off between the transport sections. They can also be used to suspend the trunking.

#### > Trolleys

These supply power to 3-phase loads.

They are fitted with graphite brushes, which through their spring action, provide contact with the conductors in the trunking, even when the trolley is in motion.

The maximum speed of movement of a trolley is 90 m/s (150ms for 63A TS).

Two trolleys can be linked to deliver double the current provided by a single trolley.

#### > Accessories

- End caps to ensure IP20 at the end of the trunking.
- Drive arms to ensure that trolleys slide properly and to damp sudden accelerations.
- Intermediate fixing clamps for suspending trunking between two joins. (allow one support every 2m).

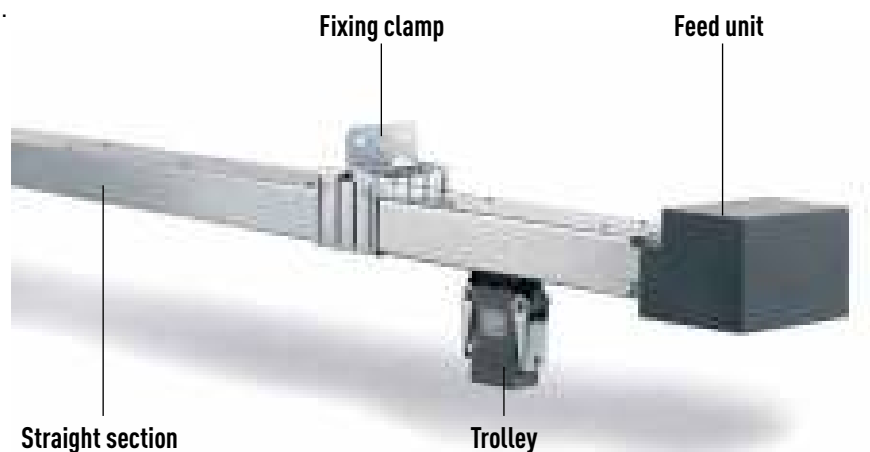

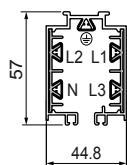

63 A

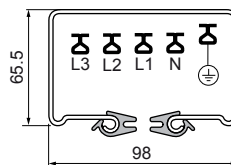

70 - 110 - 150 A

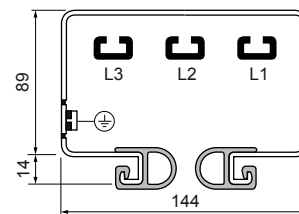

250 A

### 3.4 Technical characteristics

#### TS trunking

Model		MTS 63A	TS 5 70A	TS 5 110A	TS 150A	TS 250A
Number of active conductors	No.	3P+N+E	3P+N+E	3P+N+E	3P+N+E	3P+E
External dimensions	L x H (mm)	44.8 x 57	98 x 65.5	98 x 65.5	98 x 65.5	144 x 89
Rated current at 40°C	I <sub>n</sub> (A)	63	70	110	150	250
Conductor cross-section (3P+N)	S (mm <sup>2</sup> )	12	19	24	43	85
PE protective conductor cross-section (eq. Cu)	S <sub>PE</sub> (mm <sup>2</sup> )	12	19	24	24	120
Operating voltage	U <sub>e</sub> (V)	400	600	600	600	600
Isolation voltage	U <sub>i</sub> (V)	750	750	750	750	750
Operating frequency	f (Hz)	50/60	50/60	50/60	50/60	50/60
Short duration permissible current (0.1 sec)	I <sub>CW</sub> (kA)rms	5	9	9	9	11
Permissible peak current	I <sub>pk</sub> (kA)	7.5	15.3	15.3	15.3	18.7
Permissible thermal stress	I <sup>2</sup> t (A <sup>2</sup> s x 10 <sup>6</sup> )	25	81	81	81	121
Phase resistance	R <sub>20</sub> (mΩ/m)	1.500	0.947	0.785	0.515	0.255
Phase reactance (50Hz)	X (mΩ/m)	1.400	0.059	0.063	0.092	0.161
Phase impedance	Z (mΩ/m)	2.052	0.949	0.788	0.523	0.302
Protective conductor resistance	R <sub>PE</sub> (mΩ/m)	1.500	0.947	0.785	0.515	0.150
Protective conductor reactance (50Hz)	X <sub>PE</sub> (mΩ/m)	0.080	0.100	0.100	0.100	0.120
Fault loop resistance	R <sub>0</sub> (mΩ/m)	3.000	1.895	1.570	1.030	0.405
Fault loop reactance (50 Hz)	X <sub>0</sub> (mΩ/m)	1.480	0.159	0.163	0.192	0.281
Fault loop impedance	Z <sub>0</sub> (mΩ/m)	3.345	1.901	1.578	1.048	0.493
Linear voltage drop with uniformly distributed loads (K) (see pp. 49)	(V/m/A)10 <sup>-3</sup> cosφ = 0.70	1.775	0.611	0.515	0.369	0.254
	(V/m/A)10 <sup>-3</sup> cosφ = 0.75	1.776	0.649	0.546	0.387	0.258
	(V/m/A)10 <sup>-3</sup> cosφ = 0.80	1.767	0.687	0.577	0.405	0.260
	(V/m/A)10 <sup>-3</sup> cosφ = 0.85	1.743	0.724	0.607	0.421	0.261
	(V/m/A)10 <sup>-3</sup> cosφ = 0.90	1.698	0.761	0.636	0.436	0.260
	(V/m/A)10 <sup>-3</sup> cosφ = 0.95	1.613	0.795	0.663	0.449	0.253
(V/m/A)10 <sup>-3</sup> cosφ = 1.00	1.299	0.820	0.680	0.446	0.221	
Weight of a straight section	w (kg/m)	1.0	4.0	4.1	4.2	9.8
Calorific power with regard to fire	(m/min)	150	90	90	90	90
Degree of protection	IP	23	20	20	20	20
Losses through Joule effect at rated current	L (W/m)	17.9	13.9	28.5	34.8	47.8
Min/max ambient temperature	t (°C)	-5/+50	-5/+50	-5/+50	-5/+50	-5/+50

I<sub>n</sub>: rated current for an ambient temperature of 40°C

For use at a different ambient temperature, see p. 50

Meets standards: IEC 60439-1 and 60439-1 and 2 (change to IEC 61439-6, see p. 74), DIN VDE 0660 parts 500 and 502

"Fire retardant" meets standard IEC 20-22 (IEC 332-3: 1992).

Product suitable for use in a damp atmosphere (IEC 60068-2-3, IEC 60068-2-30)

# Prefabricated busbar trunking (continued)

## LOW-POWER TRUNKING

Legrand offers two ranges of low-power trunking:

- **LB plus**: intended mainly for lighting distribution in all types of building.
- **Easybar**: for supplying work stations in office buildings.

### 1 LB PLUS TRUNKING

#### 1.1 Applications

This trunking is suitable for distributing power in all applications up to 63A. It is usually used for lighting but is suitable for any low-power requirement.

#### 1.2 General characteristics

- Easy to install, robust product providing complete flexibility in the event of changes to premises and new system configurations.
- The trunking can take the load from added sections such as luminaires, cable tray, etc.
- Hot-galvanised steel enclosure providing electrical continuity.
- There are two types of profile available:
  - type A: standard profile - requires one fixing at least every 3 metres
  - type B: reinforced profile - the distance between fixings can be extended up to 7 metres.

Type A



Type B



- Accessories are common to both types.
- Rated current: 25, 40 or 63A.
- IP55 protection index.
- IK07 impact resistance.

- Number of conductors: 2, 4, 6 or 8 (PE conductor function provided by the metal enclosure). Suitable for the distribution of 1 or 2 single- or 3-phase circuits.

#### 1.3 Composition of the system

Sections are connected to each other simply by pushing together.

##### > Transport sections

- Straight sections
  - Lengths 1.5 m (40 and 63A) or 3m (25, 40 and 63A).
  - 2 to 12 tap-off outlets per section depending on the length, type of profile and number of conductors.
  - Tap-off outlets are fitted with captive, hinged covers.



- Flexible links
  - These allow two trunking sections to be fitted together at any angle or change of plane.

##### > Feed units

These allow the trunking to be supplied from one of its ends or from the middle. They are connected by flexible or rigid cable to screw terminals. They are supplied with a cable entry gland. End-mounting units are supplied with end caps.



### > Junction boxes

These are connected to live tap-off outlets. They lock into the trunking using a ¼ turn mechanism.

They are available in several versions:

- 10A single phase with fixed phase (a colour code provides easy identification of the phase to which they are connected), supplied with cable (1m or 3m)
- 16A single phase with phase selection, with or without fuse
- 16 and 32A 3-phase with or without fuse.

### > Accessories

- Clamps and fixing accessories for securing the trunking to the building's structure, either directly or via cables or chains.
- Hooks and rings for suspending luminaires. Bolt to fixing clamps.
- PVC ducting with cover or Cablofil cable tray for distributing wiring (data cables for example). Fix to the trunking with a special clamp.



## 1.4 Technical characteristics

Permissible additional mechanical loads <sup>(1)</sup>					
		Distance between supports (m)	△ ↓ △	△ ↓ ↓ ↓ ↓ ↓ ↓ △	
			Occasional load (kg)	Distributed loads	
LB Plus Type B	LB Plus Type A			per metre (kg/m)	total (kg)
				1.5	40
		2	30	30	60
		3	20	13	39
		5	13	5	25
		7	7	2	14

(1) Load supported in addition to the weight of the trunking itself

# Prefabricated busbar trunking (continued)

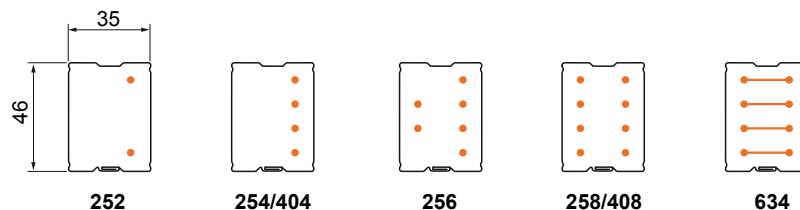

LB Plus trunking - Type A									
Version		252	254	256	258	404	408	634	
Number of active conductors	Number	2	4	6	8	4	8	4	
External dimensions	L x H (mm)	35 x 46	35 x 46	35 x 46	35 x 46	35 x 46	35 x 46	35 x 46	
Rated current at 40°C <sup>(1)</sup>	I <sub>n</sub> (A)	25	25	25	25	40	40	63	
PE protective conductor cross-section <sup>(2)</sup>	S (mm <sup>2</sup> )	91.45	91.45	91.45	91.45	91.45	91.45	91.45	
PE protective conductor cross-section <sup>(2)</sup> (eq. Cu)	S <sub>PE=Cu</sub> (mm <sup>2</sup> )	11	11	11	11	11	11	11	
Operating voltage	U <sub>e</sub> (V)	400	400	400	400	400	400	400	
Isolation voltage	U <sub>i</sub> (V)	690	690	690	690	690	690	690	
Operating frequency	f (Hz)	50/60	50/60	50/60	50/60	50/60	50/60	50/60	
Short duration permissible current (0.1 sec)	I <sub>CW</sub> (kA) <sub>rms</sub>	2.2	2.2	2.2	2.2	2.7	2.7	2.7	
Permissible peak current	I <sub>pk</sub> (kA)	4.4	4.4	4.4	4.4	5.4	5.4	5.4	
Permissible thermal stress	I <sup>2</sup> t (A <sup>2</sup> s x 10 <sup>6</sup> )	0.484	0.484	0.484	0.484	0.729	0.729	0.729	
Phase resistance at 20°C	R <sub>20</sub> (mΩ/m)	5.278	5.278	5.278	5.278	2.891	2.891	2.639	
Phase resistance at thermal equilibrium	R <sub>t</sub> (mΩ/m)	6.798	6.798	6.798	6.798	3.793	3.793	3.399	
Phase reactance (50Hz)	X (mΩ/m)	1.114	1.279	1.279	1.114	1.279	0.770	0.637	
Phase impedance	Z (mΩ/m)	5.394	5.431	5.431	5.394	5.431	2.992	2.715	
Protective conductor resistance <sup>(2)</sup>	R <sub>PE</sub> (mΩ/m)	0.203	0.203	0.203	0.203	0.203	0.203	0.203	
Protective conductor reactance (50Hz)	X <sub>PE</sub> (mΩ/m)	1.100	1.100	1.000	1.000	1.100	1.000	1.000	
Fault loop resistance	R <sub>o</sub> (mΩ/m)	5.482	5.482	5.482	5.482	3.094	3.094	2.843	
Fault loop reactance (50 Hz)	X <sub>o</sub> (mΩ/m)	2.214	2.379	2.279	2.279	1.870	1.770	1.637	
Fault loop impedance	Z <sub>o</sub> (mΩ/m)	5.912	5.976	5.936	5.936	3.615	3.565	3.280	
Linear voltage drop with uniformly distributed loads <sup>(3)</sup>	K (V/m/A)10 <sup>-3</sup> cosφ = 0.70	4.81	3.99	3.99	3.89	3.99	2.23	2.23	1.99
	K (V/m/A)10 <sup>-3</sup> cosφ = 0.75	5.05	4.16	4.16	4.07	4.16	2.32	2.32	2.08
	K (V/m/A)10 <sup>-3</sup> cosφ = 0.80	5.29	4.32	4.32	4.24	4.32	2.40	2.40	2.16
	K (V/m/A)10 <sup>-3</sup> cosφ = 0.85	5.51	4.47	4.47	4.39	4.47	2.48	2.48	2.23
	K (V/m/A)10 <sup>-3</sup> cosφ = 0.90	5.72	4.60	4.60	4.53	4.60	2.54	2.54	2.30
	K (V/m/A)10 <sup>-3</sup> cosφ = 0.95	5.89	4.69	4.69	4.64	4.69	2.59	2.59	2.34
	K (V/m/A)10 <sup>-3</sup> cosφ = 1.00	5.89	4.57	4.57	4.57	4.57	2.50	2.50	2.29
Weight	w (kg/m)	1.00	1.04	1.25	1.28	1.19	1.56	1.56	
Calorific power with regard to fire	(m/min)	1.03	1.03	1.91	1.91	1.0	1.9	1.9	
Degree of protection	IP	55	55	55	55	55	55	55	
Degree of resistance to mechanical impacts	IK	07	07	07	07	07	07	07	
Losses through Joule effect at rated current	L (W/m)	12.7	12.7	12.7	12.7	18.2	18.2	40/5	
Min/max ambient temperature	t (°C)	-5/+50	-5/+50	-5/+50	-5/+50	-5/+50	-5/+50	-5/+50	

(1) For use at a different ambient temperature, see pp. 50

(2) Metal enclosur

(3) Voltage drop calculations: see p. 51

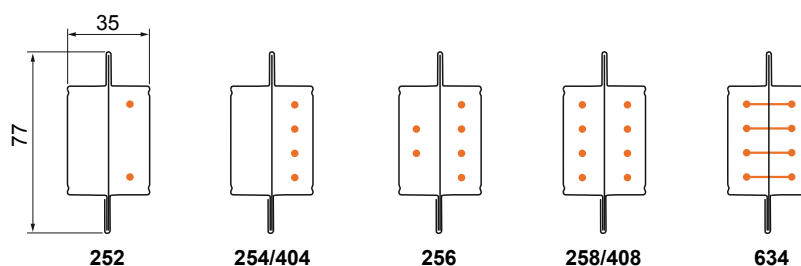

### LB Plus trunking - Type B

Version		252	254	256	258	404	408	634	
Number of live conductors	No.	2	4	6	8	4	8	4	
External dimensions	L x H (mm)	35 x 77	35 x 77	35 x 77	35 x 77	35 x 77	35 x 77	35 x 77	
Rated current at 40°C <sup>(1)</sup>	I <sub>n</sub> (A)	25	25	25	25	40	40	63	
PE protective conductor cross-section <sup>(2)</sup>	S (mm <sup>2</sup> )	195	195	195	195	195	195	195	
PE protective conductor cross-section <sup>(2)</sup> (eq. Cu)	S <sub>PE[=CU]</sub> (mm <sup>2</sup> )	24	24	24	24	24	24	24	
Operating voltage	U <sub>e</sub> (V)	400	400	400	400	400	400	400	
Isolation voltage	U <sub>i</sub> (V)	690	690	690	690	690	690	690	
Operating frequency	f (Hz)	50/60	50/60	50/60	50/60	50/60	50/60	50/60	
Short duration permissible current (0.1 sec)	I <sub>CW</sub> (kA) <sub>rms</sub>	2.5	2.5	2.5	2.5	3.2	3.2	3.2	
Permissible peak current	I <sub>pk</sub> (kA)	5	5	5	5	6.4	6.4	6.4	
Permissible thermal stress	I <sup>2</sup> t (A <sup>2</sup> s x 10 <sup>6</sup> )	0.625	0.625	0.625	0.625	1.024	1.024	1.024	
Phase resistance at 20°C	R <sub>20</sub> (mΩ/m)	5.278	5.278	5.278	5.278	2.891	2.891	2.639	
Phase resistance at thermal equilibrium	R <sub>t</sub> (mΩ/m)	6.798	6.798	6.798	6.798	3.793	3.793	3.399	
Phase reactance (50Hz)	X (mΩ/m)	1.400	1.270	1.270	1.400	1.270	0.770	0.637	
Phase impedance	Z (mΩ/m)	5.461	5.429	5.429	5.461	5.429	2.992	2.715	
Protective conductor resistance <sup>(2)</sup>	R <sub>PE</sub> (mΩ/m)	0.434	0.434	0.434	0.434	0.434	0.434	0.434	
Protective conductor reactance (50Hz)	X <sub>PE</sub> (mΩ/m)	1.100	1.100	1.000	1.000	1.100	1.000	1.000	
Fault loop resistance	R <sub>o</sub> (mΩ/m)	5.712	5.712	5.712	5.712	3.325	3.325	3.073	
Fault loop reactance (50Hz)	X <sub>o</sub> (mΩ/m)	2.500	2.370	2.270	2.270	1.870	1.770	1.637	
Fault loop impedance	Z <sub>o</sub> (mΩ/m)	6.235	6.184	6.147	6.147	3.814	3.766	3.482	
Linear voltage drop with uniformly distributed loads <sup>(3)</sup>	K (V/m/A)10 <sup>-3</sup> cosφ = 0.70	4.07	3.99	3.99	4.07	3.99	2.23	2.23	1.99
	K (V/m/A)10 <sup>-3</sup> cosφ = 0.75	4.23	4.16	4.16	4.23	4.16	2.32	2.32	2.08
	K (V/m/A)10 <sup>-3</sup> cosφ = 0.80	4.38	4.32	4.32	4.38	4.32	2.40	2.40	2.16
	K (V/m/A)10 <sup>-3</sup> cosφ = 0.85	4.52	4.46	4.46	4.52	4.46	2.48	2.48	2.23
	K (V/m/A)10 <sup>-3</sup> cosφ = 0.90	4.64	4.59	4.59	4.64	4.59	2.54	2.54	2.30
	K (V/m/A)10 <sup>-3</sup> cosφ = 0.95	4.72	4.69	4.69	4.72	4.69	2.59	2.59	2.34
	K (V/m/A)10 <sup>-3</sup> cosφ = 1.00	4.57	4.57	4.57	4.57	4.57	2.50	2.50	2.29
Weight	w (kg/m)	1.80	1.83	2.02	2.02	1.98	2.33	2.33	
Calorific power with regard to fire	(m/min)	1.1	1.1	2.1	2.1	1.1	2.1	2.1	
Degree of protection	IP	55	55	55	55	55	55	55	
Degree of resistance to mechanical impacts	IK	07	07	07	07	07	07	07	
Losses through Joule effect at rated current	L (W/m)	12.7	12.7	12.7	12.7	18.2	18.2	40.5	
Min/max ambient temperature	t (°C)	-5/+50	-5/+50	-5/+50	-5/+50	-5/+50	-5/+50	-5/+50	

(1) For use at a different ambient temperature, see p. 50

(2) Metal enclosure

(3) Voltage drop calculations: see p. 51

# Prefabricated busbar trunking (continued)

## 2 EASYBAR TRUNKING

### 1.1 Applications

This trunking is suitable for distribution up to 40A. It is specially designed for use in reduced spaces (raised access floors, suspended ceiling voids). It is often used for supplying power to workstations via the floor in office suites (open spaces) or to supply lighting in a ceiling.

### 1.2 General characteristics

- Low space requirement (trunking height: 17mm - max. height with components: 50 mm).
- Is installed flat in raised access floors and suspended ceilings.
- Hot-galvanised steel enclosure providing electrical continuity.
- Rated current: 25 or 40A.
- IP55 protection index with lid (IP xxB without lid).
- Number of conductors: 4 (PE conductor provided by the metal enclosure). Allows one 3-phase or two single-phase circuits to be distributed.

### 1.3 Composition of the system

Sections are connected to each other simply by pushing together.

#### > Transport sections

- Straight sections
- They can accept junction connectors at any point. They are supplied with a break-off lid and a joining section for connection to another straight section. 2 m and 3 m lengths.



#### • Flexible links

These allow changes of direction between sections at any angle. They allow obstacles to be avoided.

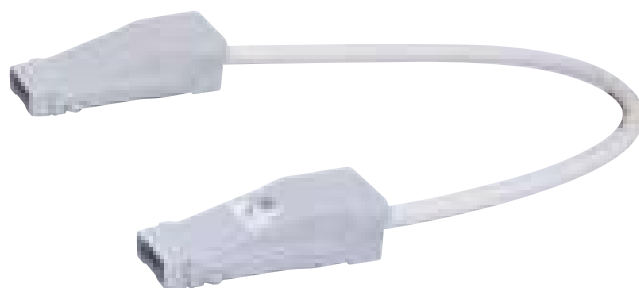

#### > Feed units

These allow the trunking to be supplied from one of its ends.

They are supplied with end covers. They are connected by flexible or rigid cable to screw terminals.



#### > Junction connector

They plug in at any point in the trunking. They can be connected and disconnected in complete safety by moving the cover out of the way.

They are available in several versions:

- 10A single phase, with or without fuse, with 1 metre of cable.
- 16A single phase, with or without fuse, with 3 or 5 metres of cable.
- 16A 3-phase with or without fuse, with 3 or 5 metres of cable.



Disconnected

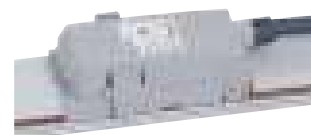

Connected

## > Accessories

- Fixing clips

They are fixed to the ground, on the side of cable tray or to the ceiling, to accept straight sections by simple snapfit.

- Safety accessory

They allow connectors to be locked off in the disconnected position by a padlock.



## 1.4 Technical characteristics

Easybar trunking			
Version		25A	40A
Number of live conductors	No.	4	4
External dimensions	L x H (mm)	51.4 x 18	51.4 x 18
Rated current at 40°C <sup>(1)</sup>	I <sub>n</sub> (A)	25	40
PE protective conductor cross-section <sup>(2)</sup> (eq. Cu)	S <sub>PE(=CU)</sub> (mm <sup>2</sup> )	6.1	6.1
Operating voltage	U <sub>e</sub> (V)	400	400
Isolation voltage	U <sub>i</sub> (V)	500	500
Operating frequency	f (Hz)	50/60	50/60
Short duration permissible current (0.1 sec)	I <sub>cw</sub> (kA)rms	2.2	2.7
Permissible peak current	I <sub>pk</sub> (kA)	10	10
Permissible thermal stress	I <sup>2</sup> t (A <sup>2</sup> s x 10 <sup>6</sup> )	0.48	0.73
Phase resistance at 20°C	R <sub>20</sub> (mΩ/m)	4.75	2.99
Phase reactance (50Hz)	X (mΩ/m)	1.279	0.77
Phase impedance	Z (mΩ/m)	4.919	3.088
Protective conductor resistance <sup>(2)</sup>	R <sub>PE</sub> (mΩ/m)	2.99	2.99
Protective conductor reactance (50Hz)	X <sub>PE</sub> (mΩ/m)	1.07	1.07
Fault loop resistance	R <sub>o</sub> (mΩ/m)	8.34	6.36
Fault loop reactance (50Hz)	X <sub>o</sub> (mΩ/m)	2.349	1.84
Fault loop impedance	Z <sub>o</sub> (mΩ/m)	8.66	6.62
Linear voltage drop with uniformly distributed loads <sup>(3)</sup>	K (V/m/A)10 <sup>-3</sup> cosφ = 0.70	4.24	2.64
	K (V/m/A)10 <sup>-3</sup> cosφ = 0.75	4.21	2.62
	K (V/m/A)10 <sup>-3</sup> cosφ = 0.80	5.73	4.26
	K (V/m/A)10 <sup>-3</sup> cosφ = 0.85	3.11	3.11
	K (V/m/A)10 <sup>-3</sup> cosφ = 0.90	4.60	3.73
	K (V/m/A)10 <sup>-3</sup> cosφ = 0.95	8.66	6.61
	K (V/m/A)10 <sup>-3</sup> cosφ = 1.00	2.35	1.84
Weight of straight sections	w (kg/m)	0.78	0.93
Calorific power with regard to fire	(m/min)	0.82	0.82
Degree of protection	IP	55	55
Losses through Joule effect at rated current	L (W/m)	8.91	14.35
Min/max ambient temperature	t (°C)	-5/+50	-5/+50

(1) For use at a different ambient temperature, see p. 50

(2) Metal enclosure

(3) Voltage drop calculations: see p. 51

# Cable tray and ducting

The technical characteristics of cable tray and ducting provide great flexibility of installation. These solutions are in widespread use and provide a good compromise between performance, ease of use and cost. There is a wide variety of products, each with its specific uses.

## OVERVIEW

### 1 CABLE LADDER

This provides discontinuous support with the cables resting on the rungs spaced at a greater or lesser distance between two side beams.

Its robustness allows it to support significant loads (large section cables) and to bridge long spans (up to 8 m). It is mainly found in industrial facilities.



### 2 WIRE CABLE TRAY

Usually made of welded steel wires, it is widely used, on account of its ease of use and great flexibility. Its completely open structure facilitates ventilation and allows permissible current calculations to be made by treating it in a similar way to cable ladder: fitting mode E and F (see Book 4).



This open structure also ensures very easy cleaning, which makes wire cable tray of great value in the food and chemical industries, purification stations and naval construction.

It also allows quick changes of direction and level without the necessity for special accessories. For both the industrial and office sectors, this is a good compromise from a cost and a technical point of view.

### 3 SHEET METAL OR PVC CABLE TRAY

In galvanised or painted sheet steel or in stainless steel or PVC, solid or perforated, it can be fitted with a lid.

It allows a large number of cables to be supported and is often used in industrial and office building environments.

The use of perforated cable tray improves ventilation while providing good protection for cables.

It can be fitted with partitions to compartment the various distribution networks. It is usually used for power distribution but can also distribute all services (telephony, data, audio, video, etc.).

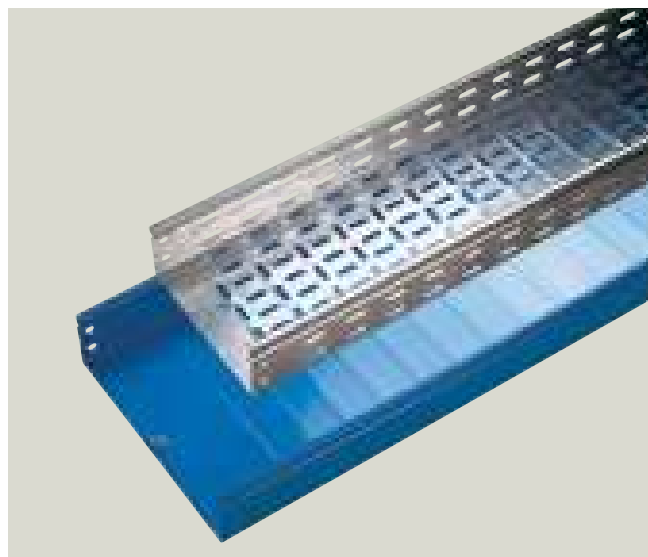

## 4 DUCTING

This is used for visible distribution along walls or ceilings as well as in industrial, office and residential sectors. Depending on its use, it can be PVC, GRP, sheet steel or aluminium. It is often used for renovations or extensions to installations. It is also used in temporary installations. Some ducting has compartments, allowing for a separation between high-current cables and low current cables (telephone, television, etc.). It is usually fitted with lids, and accessories allow all sorts of angles to be negotiated so as to adapt to all types of premises.



Terminal wiring accessories are fitted directly into the trunking: power sockets, RJ45 connectors, etc.



**Legrand anodised aluminium trunking guarantees a level of safety equivalent to double insulation, since it has an internal PVC partition and does not require earthing.**

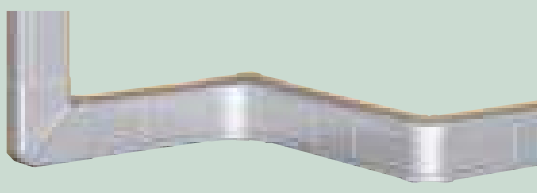

Standard EN 50085-1 for trunking and profiled ducting systems provide for a check on behaviour with regard to the fire risk in respect of outbreaks of fire and its spread. For the first aspect, verification is done using a glow-wire test in accordance with standard IEC 60695-2-11 (at 850°C for parts containing active electrical elements and at 650°C for other parts). For the second aspect, verification is effected using a spread test with a burner described in standard IEC 60695-2-4/1.

The isolation resistance should not be less than 100 MΩ and dielectric rigidity should be adapted to the declared isolation voltage ( $2U_i + 1000V$ ).

Other mechanical characteristics are defined by standard EN 50085-2. The degree of protection against impacts must be adapted to the conditions of use (see book 8). The IK07 of Legrand DLP ducting allows it to be used in the majority of multiple-occupancy premises, whether commercial or domestic.

## 5 SKIRTING TRUNKING AND MOULDINGS

This is an elegant solution for distribution along floors and around doors and windows in offices or houses. These conduits can be fitted with lids with rounded edges to facilitate cleaning. They can have several compartments to separate the different types of conductor.

## 6 FLOOR DUCTING

Used for laying cables along the ground, in particular in open-plan offices, where it can be easily fitted or moved.

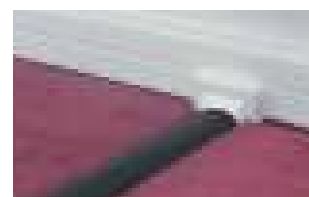

# Cable tray and trunking (continued)

## CABLOFIL® CABLE TRAY

### 1 GENERAL CHARACTERISTICS

Cablofil cable tray is made from a welded steel wire mesh.

It is available in a wide range of sizes between 30 and 150mm high and 35 to 600mm wide.

The choice of anti-corrosion protection treatment allows it to be used in all environments (see page 36).

Cablofil protective coatings:

**PG** : continuous galvanisation prior to manufacture

**EZ** : electrolytic zinc plating after manufacture

**GC** : hot-dip galvanisation after manufacture

**304L** : stainless steel 1.4307

**316L** : stainless steel 1.4404

A range of profiles provides a response to special situations: vertical fitting, raised access floor, confined space, etc.

Cablofil cable tray can be fitted with an optional lid and separating partitions.

### 2 SYSTEM COMPOSITION

The Cablofil system essentially comprises 3m-long straight sections.

Cablofil cable tray does not require any special accessories. It is not necessary, as is the case with other types of cable tray, to have tees, crossovers, elbows, bayonets, reducers, etc. All these fittings are created from standard straight product sections. Bolt cutters are the only tool required.

Simply cut and fold to form a bend. This flexibility allows it to follow the shape of the construction wherever required (walls, ceilings, roof structures, etc.), to go around obstacles or over or under them. The overall cost of the installation is reduced and the administration of which parts to order is greatly simplified.

The Cablofil system has numerous accessories - supports, brackets and hangers to adapt to any situation: depending on the cable load, the position (vertical or horizontal), depending on the number of lengths involved, depending on the fixing (suspended, lateral, on uprights or on a frame).

Supports are designed to allow cables to be fitted laterally, through the side of the cable tray. It is not necessary to pull cables with all the risks involved of them becoming caught or the insulation being damaged, not to mention the fact that it is difficult work.

This access from the side also makes working much easier, even the removal and re-fitting of a conductor without the need to take down the supports.

All support accessories are offered with the same range of finishes and the same anti-corrosion finishes as the tray itself. Most offer a choice of assembly mode, screw-together or quick screwless mode: FAS (Fast Assembling System).

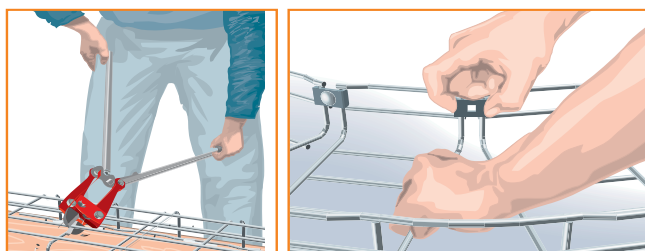

### Choice of Cablofil cable tray

Usable height (mm)	Type	Usable width (mm)										
		35	50	100	150	200	300	400	450	500	600	
30	CF30		EZ GC 304L 316L	EZ GC 304L 316L	EZ GC 304L 316L	EZ GC 304L 316L	EZ GC 304L 316L	EZ GC 304L 316L	EZ	EZ	EZ	EZ
	UF30	-	-	-	-	-	EZ	EZ	EZ	EZ	-	
35	TXT35	EZ GC 304L 316L	-	-	-	-	-	-	-	-	-	
50	G-mini	-	EZ 316L	-	-	-	-	-	-	-	-	
	CFC	-	GC 304L 316L	GC 304L 316L	-	GC 304L 316L	GC 304L 316L	GC 304L 316L	-	-	-	
	CFG	-	-	EZ GC	EZ GC	EZ GC	-	-	-	-	-	
54	FCF54	-	PG EZ 304L 316L	PG EZ 304L 316L	PG EZ 304L 316L	PG EZ 304L 316L	-	-	-	-	-	
	PCF54	-	PG EZ GC	PG EZ GC	PG EZ GC	PG EZ GC	PG EZ GC	PG EZ GC	PG EZ GC	PG EZ GC	PG EZ GC	
	CF54	-	PG EZ GC 304L 316L	PG EZ GC 304L 316L	PG EZ GC 304L 316L	PG EZ GC 304L 316L	PG EZ GC 304L 316L	PG EZ GC 304L 316L	EZ GC 304L GC	PG EZ GC	EZ GC 304L 316L	
80	CF80	-	-	EZ GC	-	EZ GC	EZ GC	EZ GC	-	EZ GC	-	
105	CF105	-	-	EZ GC 304L 316L	EZ GC 304L 316L	EZ GC 304L 316L	EZ GC 304L 316L	EZ GC 304L 316L	EZ	EZ GC 304L 316L	EZ GC 304L 316L	
	HDF	-	-	EZ GC 316L	EZ GC 316L	EZ GC 316L	EZ GC 316L	EZ GC 316L	EZ GC 316L	EZ GC 316L	EZ GC 316L	
150	CF150	-	-	-	-	EZ GC	EZ GC	EZ GC	EZ GC	EZ GC	-	

# Cable tray and trunking (continued)

## 3 EARTHING

Under normal working conditions, metal cable trays guarantee electrical continuity. To ensure the safety of persons through indirect contact, it is recommended to connect earth using a conductor with a minimum section of 16 mm<sup>2</sup>.

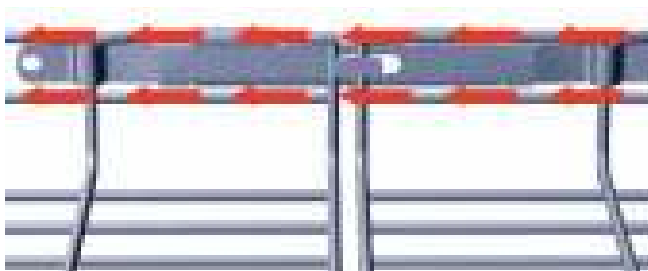

Couplers provide electrical continuity

## 4 PARTITION FEEDTHROUGH

Where cable tray has to pass through a wall, it should be stopped at a distance of approximately 100mm from the wall. The electrical continuity between the two segments on either side of the wall must be maintained by a protective conductor. If the characteristics of the rooms separated by the wall are different, humidity, gas or fire could be a source of danger. The opening in the wall must therefore be made safe, using appropriate systems (see page 43).

## 5 MECHANICAL STRENGTH

Cablofil cable tray has very good load-bearing strength. The use of drawn steel with a high elastic limit ( $R_e > 650$  MPa) and its geometric design allow beams with an optimum bending moment (vertical sides) to be put together. The result is that Cablofil is very safe in use in the event of overloading or abnormal external stresses such as vibration or even



EZ Path fire-break partition feedthrough

seismic movements. The cable tray may distort but the system will absorb the stresses without breaking. This intrinsic safety guarantee inherent to Cablofil applies to the whole system; connection devices (couplers) are not weak points and mechanical cohesion remains intact for both the screwed and screwless (FAS) accessory ranges. The mechanical performance of all products and accessories is tested in accordance with the requirements of international standard IEC 61537 (see p. 69).



If seriously overloaded, the mesh structure of Cablofil cable tray will sag but it will not break.

## Permissible load

This is the maximum load that the cable tray can support. It relates to a uniformly distributed load and is expressed in DaN/m.

The standard sets a maximum deflection of 1/100<sup>th</sup> of the span. So, for a 2 metre span, the standard allows a deflection of 20mm. Legrand, being more demanding, deliberately limits deflection to 10mm (1/200<sup>th</sup> of the span).

## The choice and location of the supports

Brackets are identified by their permissible loads (in DaN). Hangers are identified by their permissible torques (in DaN.m).

The spacing of supports must be adapted to the actual load on the cable tray.

A support must be positioned before every change in the cable tray plane. It is also recommended that a support is positioned before and after right angle bends. For large radius bends, position an additional support in the middle of the bend.



## Importance of coupling type and positioning

**To optimise the performance of the run, the choice of couplers is as important as their position in the row. Cablofil couplers are designed and tested for high mechanical and electrical performance.**

**To get the full benefit, the recommendations below, which are valid for all spans, should be followed.**

**For optimum performance the join should be positioned at one fifth of the span (L/5).**

**It is possible to position the coupler in the middle of the span (L/2) on condition that a coefficient of 0.7 is applied to the permissible load.**

**Note: never put a coupler and a support on top of each other.**



## Optimum configuration for a 2 metre span

**There is an optimum configuration for obtaining 2 metre spans without the couplers interfering with the supports or being in the middle of the span.**

**To achieve this, the first row is deliberately limited to 1.5 metres and supports are then spaced at 2 metres. Couplers are therefore always 0.5m from a support. Following this configuration, coupled with the quality and penetration of the welding of the wires, ensures optimum performance with a span of 2 metres.**

# Cable tray and trunking (continued)

## Permissible load on Cablofil cable tray

CF30 PG EZ GC

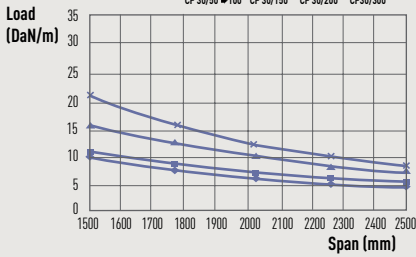

CF30 304L 316L

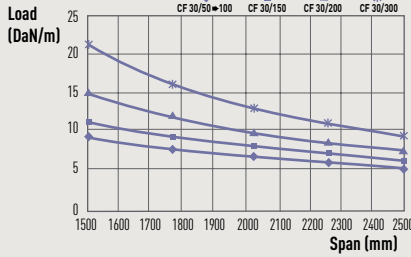

CF54 PG EZ GC

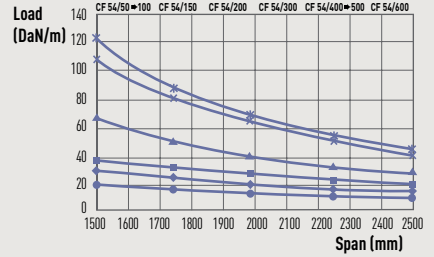

CF54 304L 316L

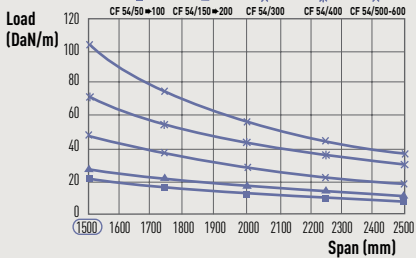

CF80 EZ GC

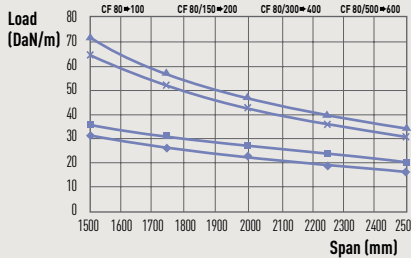

CF 105 EZ GC

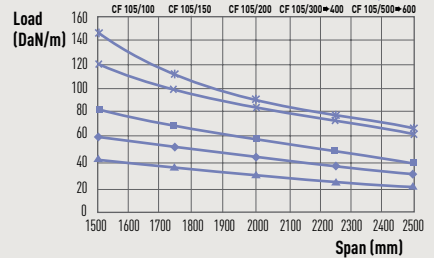

CF105 304L 316L

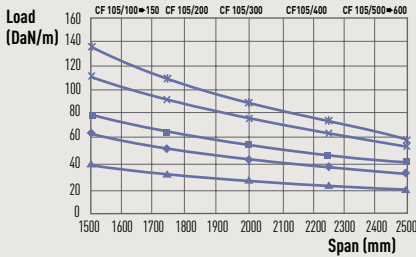

CF150 EZ GC

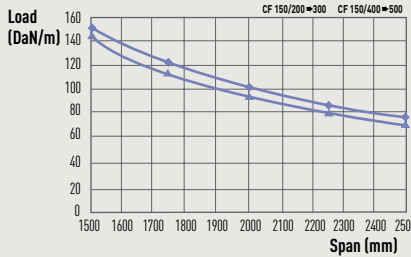

CFC GC

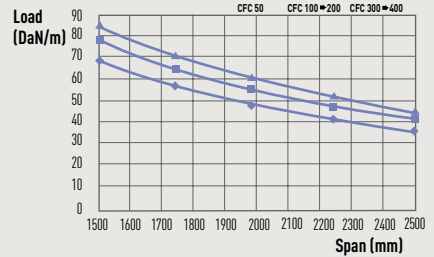

CFC 304L 316L

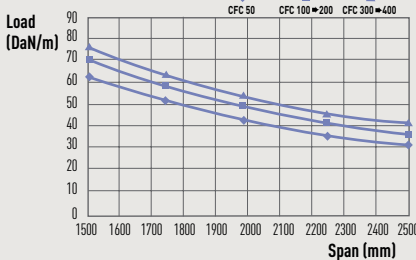

HDF EZ GC

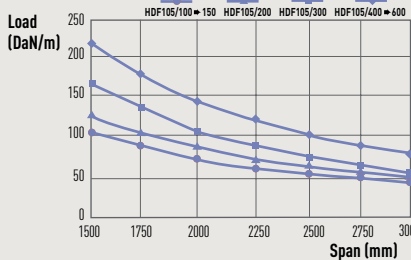

HDF 316L

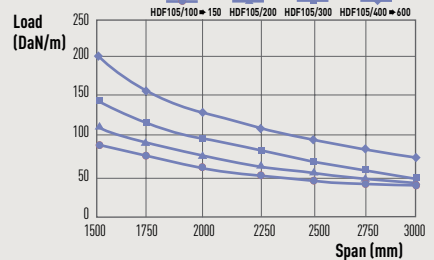

Permissible load for a deflection no greater than 1/200 with the coupling at 1/5 of the span



## POWER GUIDE: A complete set of technical documentation



01 | Sustainable development



08 | Protection against external disturbances



02 | Power balance and choice of power supply solutions



09 | Operating functions



03 | Electrical energy supply



10 | Enclosures and assembly certification



04 | Sizing conductors and selecting protection devices

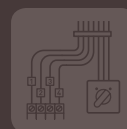

11 | Cabling components and control auxiliaries



05 | Breaking and protection devices

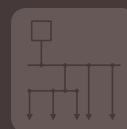

12 | Busbars and distribution



06 | Electrical hazards and protecting people



13 | Transport and distribution inside an installation



07 | Protection against lightning effects



Annexes  
Glossary  
Lexicon



**World Headquarters and  
International Department**  
87045 Limoges Cedex - France  
☎ : + 33 (0) 5 55 06 87 87  
Fax : + 33 (0) 5 55 06 74 55