

PROTECTION OF MV TRANSFORMERS AT UTILITY AND INDUSTRIAL FACILITIES

Chuck Mozina
Consultant
Beckwith Electric

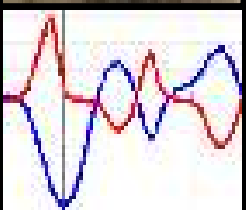

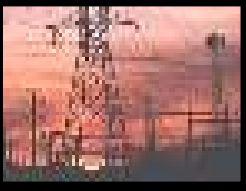
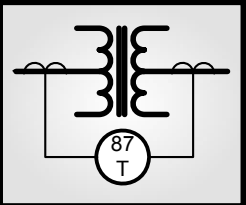
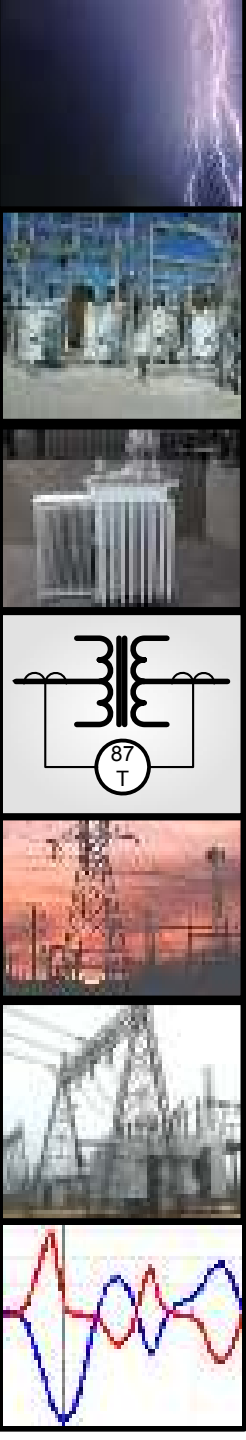

Chuck Mozina -- is a Consultant, Protection and Protection Systems for Beckwith Electric and resides in Palm Harbor (near Tampa), Florida. His consulting practice involves projects relating to protective relay applications, protection system design and coordination. He specializes in generator and power plant protection.

Chuck is an active 25-year member of the IEEE Power System Relay Committee (PSRC) and is the past chairman of the Rotating Machinery Subcommittee. He is active in the IEEE IAS I&CPS, PCIC and PPIC committees, which address industrial system protection. He is a former U.S. representative to the CIGRE Study Committee 34 on System Protection and has chaired a CIGRE working group on generator protection. He also chaired the IEEE task force that produced the tutorial "The Protection of Synchronous Generators," which won the PSRC's 1997 Outstanding Working Group Award. Chuck is the 1993 recipient of the Power System Relay Committee's Career Service Award and he recently received the 2002 IAS I&CPS Ralph Lee Prize Paper Award. His papers have been republished in the IAS Industrial Applications Magazine.

Chuck has a Bachelor of Science in Electrical Engineering from Purdue University and is a graduate of the eight month GE Power System Engineering Course. He has authored a number of papers and magazine articles on protective relaying. He has over 25 years of experience as a protection engineer at Centerior Energy, a major investor-owned utility in Cleveland, Ohio where he was the Manager of the System Protection Section. He spent 10 years as the Applications Manager for Relay Products for Beckwith Electric. He is also a former instructor in the Graduate School of Electrical Engineering at Cleveland State University as well as a registered Professional Engineer in the state of Ohio and a Life Fellow of the IEEE.

OUTLINE

- IEEE PROTECTION STANDARDS
- WHY TRANSFORMERS FAIL
- TRANSFORMER BASICS
- PHASING STANDARDS
 - + IEEE/ANSI
 - + IEC
- TRANSFORMER DIFFERENTIAL
 - + Phase (87T)
 - + Gnd (87GD)
- OVEREXCITATION PROTECTION
- DIGITAL TRANSFORMER RELAYS

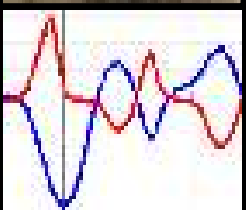
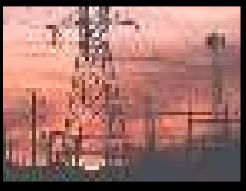
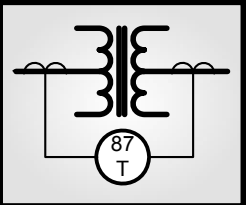

IEEE Standards

- Latest developments reflected in:
 - Std. 242: Buff Book Transformer Protection Chapter 11
 - ANSI / IEEE C37.91 “Guide for Protective Relay Applications for Power Transformers”

*These are created/maintained by the IEEE PSRC & IAS
They are updated every 5 years*

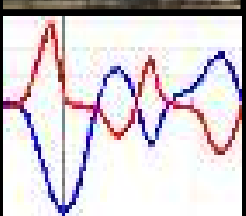
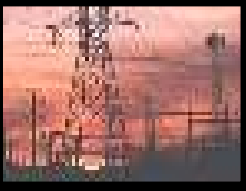
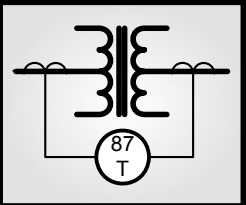

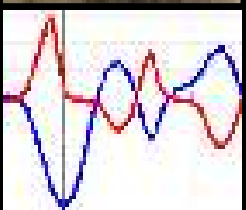
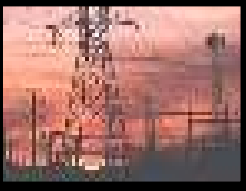
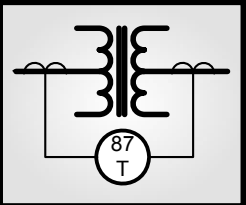

WHY TRANSFORMERS FAIL

What Fails in Transformers?

- Windings
 - Insulation deterioration from
 - Moisture
 - Overheating
 - Vibration
 - Voltage surges
 - Mechanical Stress from through-faults
- LTCs
 - Malfunction of mechanical switching mechanism
 - High resistance contacts
 - Overheating
 - Contamination of insulating oil

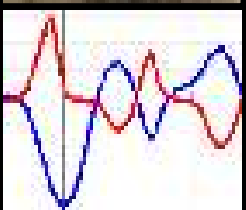
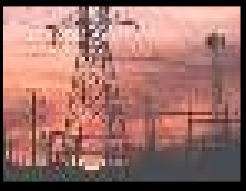
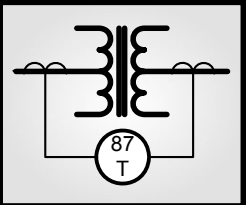

What Fails in Transformers?

HARTFORD STEAM BOILER INSPECTION & INSURANCE CO.

Cause	% of Failures
Insulation Failure	26%
Manufacturing Problems	24%
Unknown	16%
Loose Connections	7%
Through Faults	5%
Improper Maintenance	5%
Oil Contamination	4%
Overloading	4%
Fire/Explosions	3%
Lighting	3%
Floods	2%
Moisture	1%

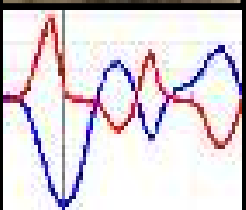
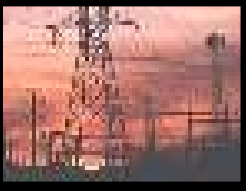
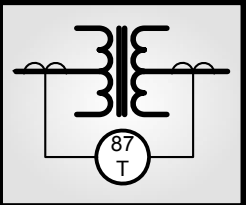

Through Fault Category 3 5-30 MVA

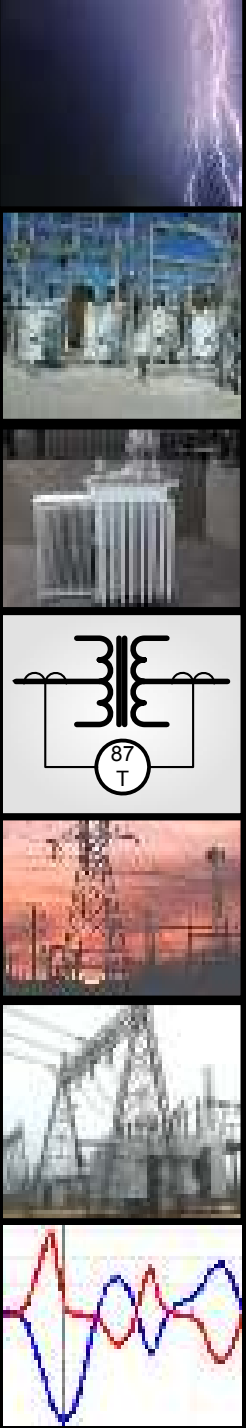
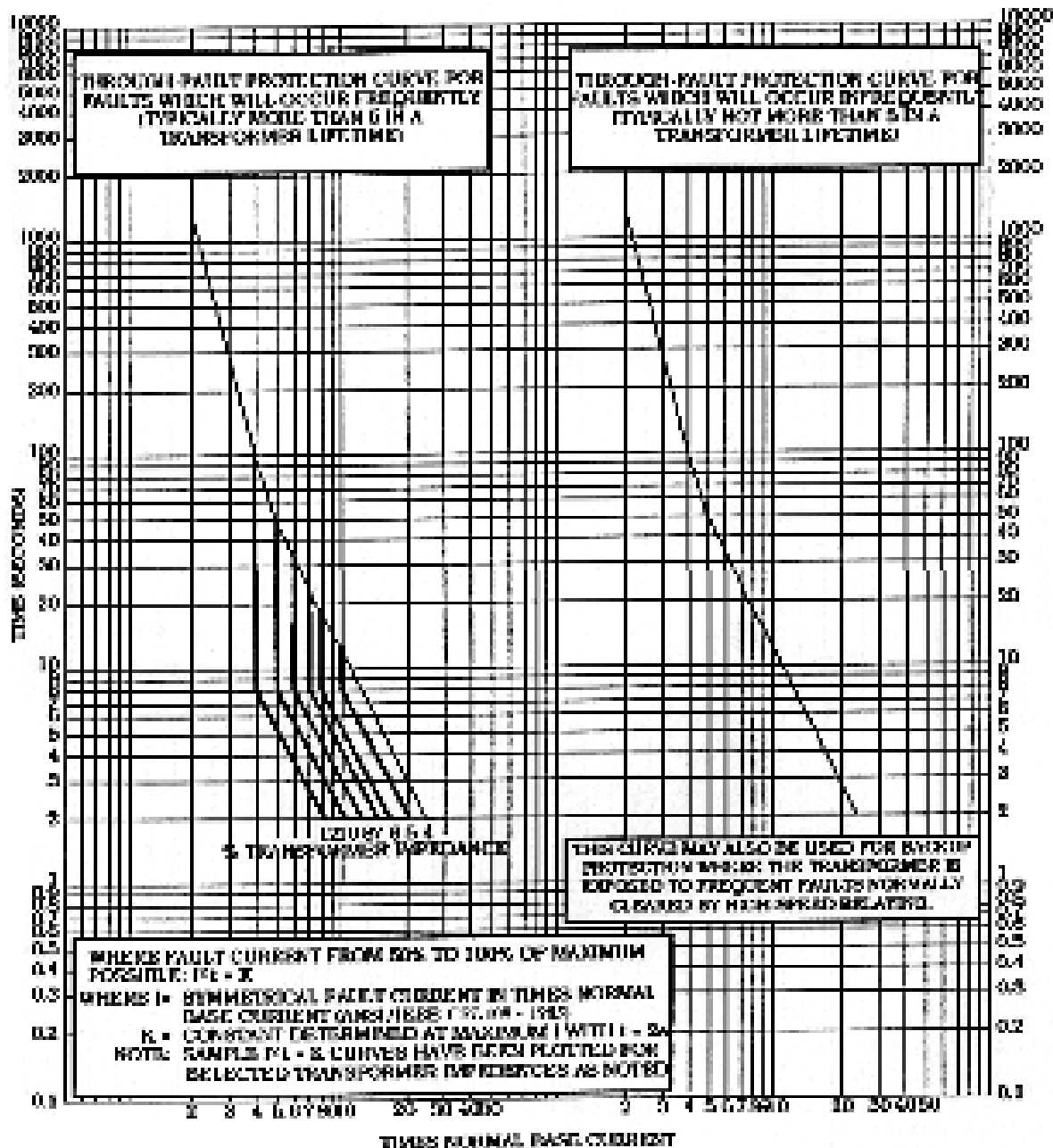

Through Fault Category 4 Larger than 30 MVA

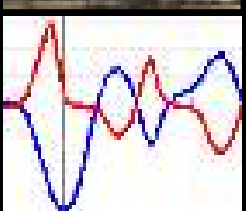
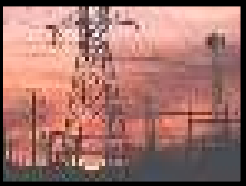
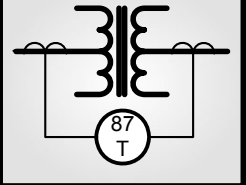
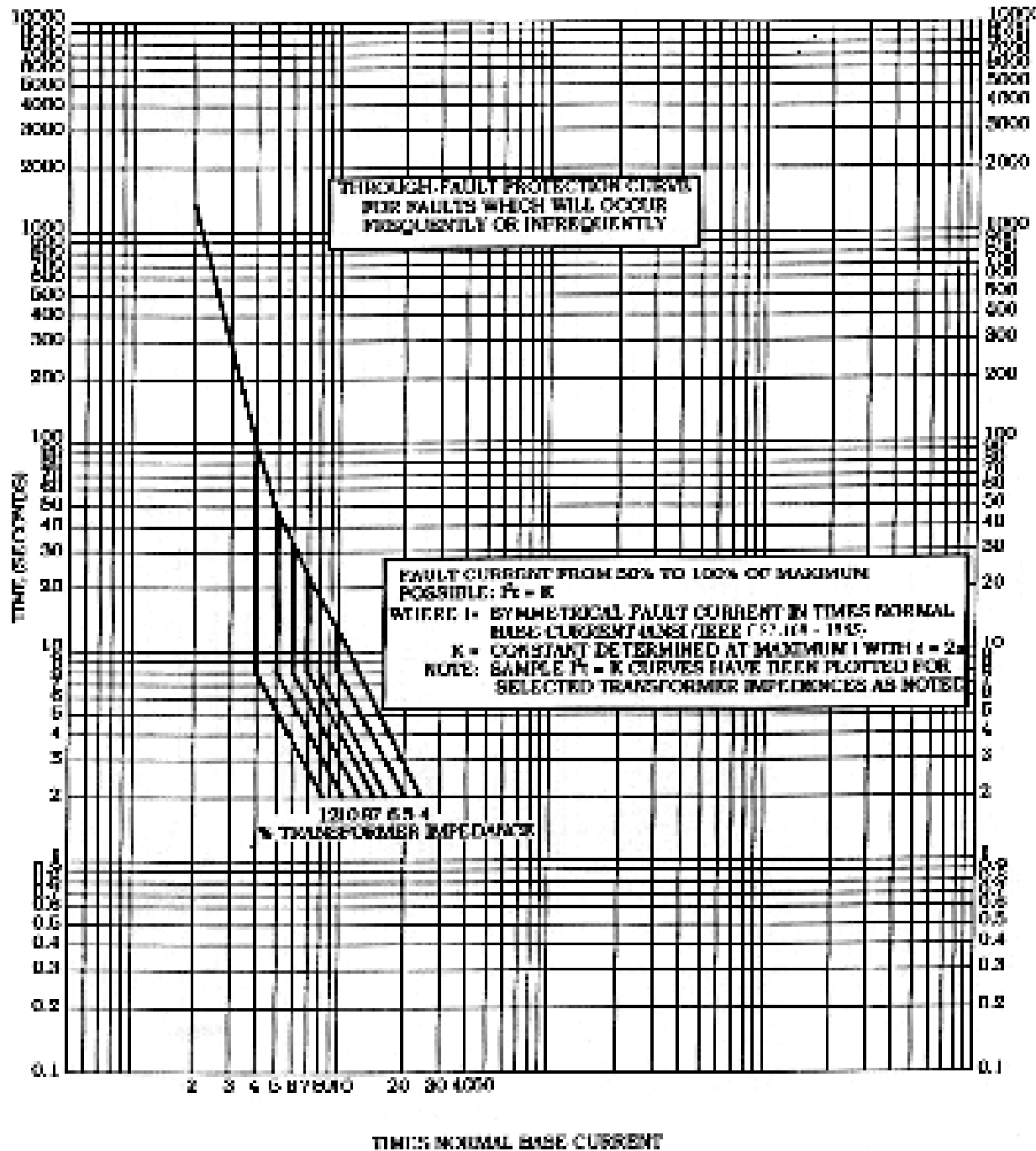

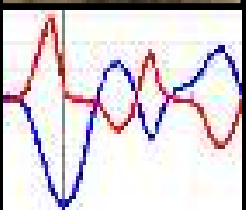
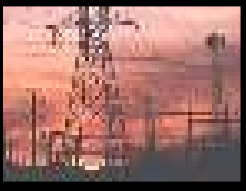
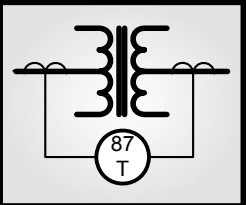

TRANSFORMER PROTECTION BASICS

Transformer Formulas

- $V_1 I_1 = V_2 I_2$
- $N_1 V_2 = N_2 V_1$
- $N_1 I_1 = N_2 I_2$

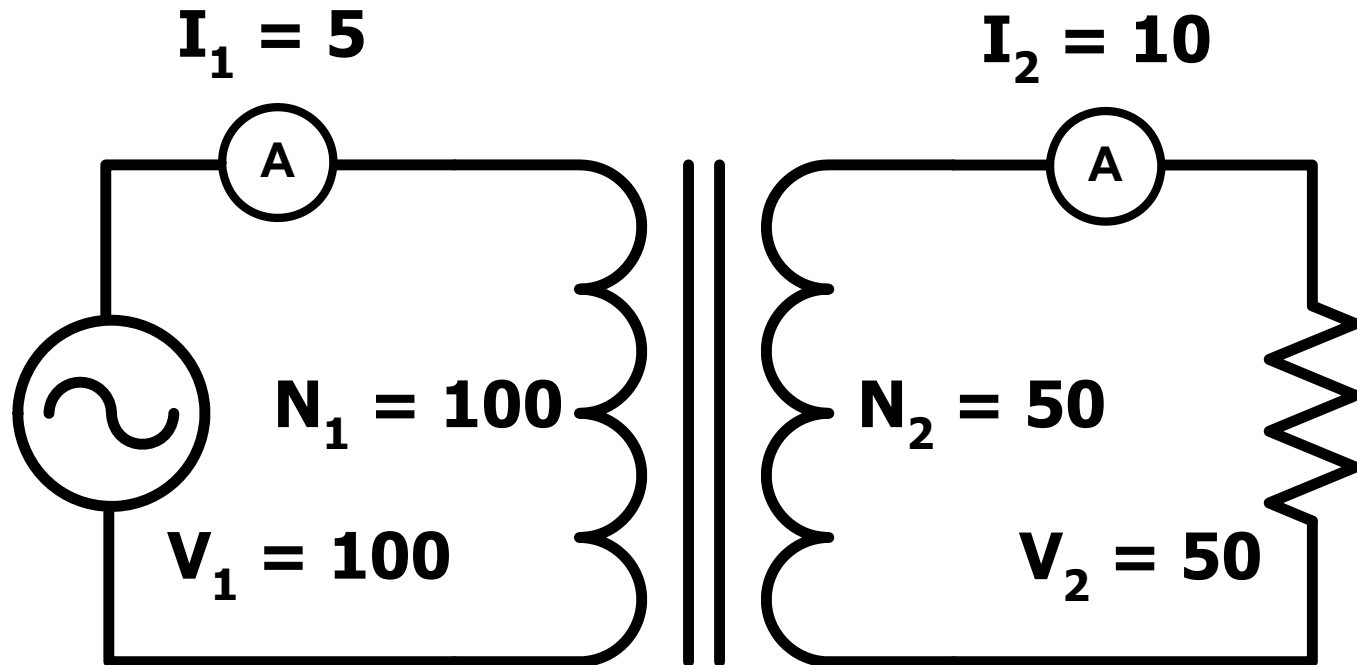

Ideal Transformer – No Losses

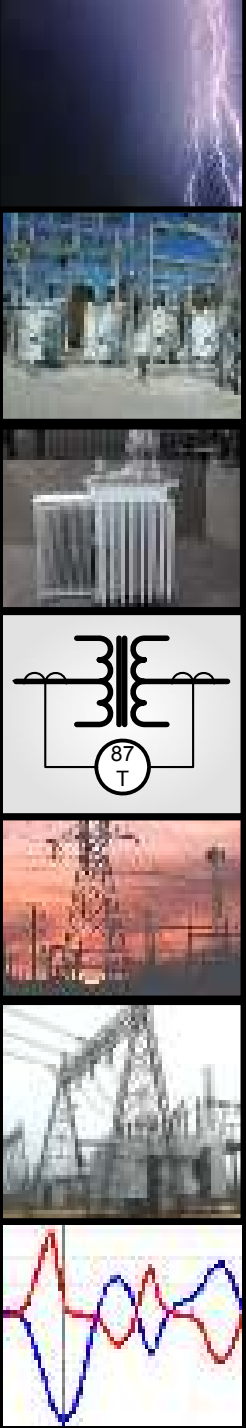

INSULATION MATERIALS

- **Dry**

- Used where liquid spills cannot be tolerated
- Small ratings, lower voltage distribution

- **Wet**

- Offers smaller size, lower cost and greater overload capacity
- Liquids have greater coefficient of heat transfer than dry insulation
- Vast majority of power transformers use wet (oil) insulation.

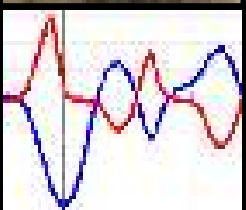
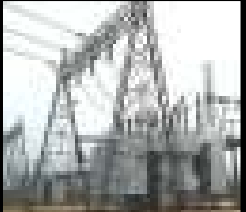
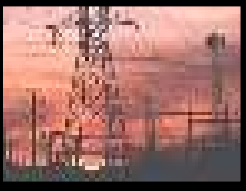
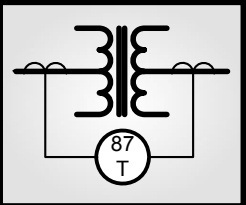

Basic Transformer Designs

Gas-Oil Sealed Transformers

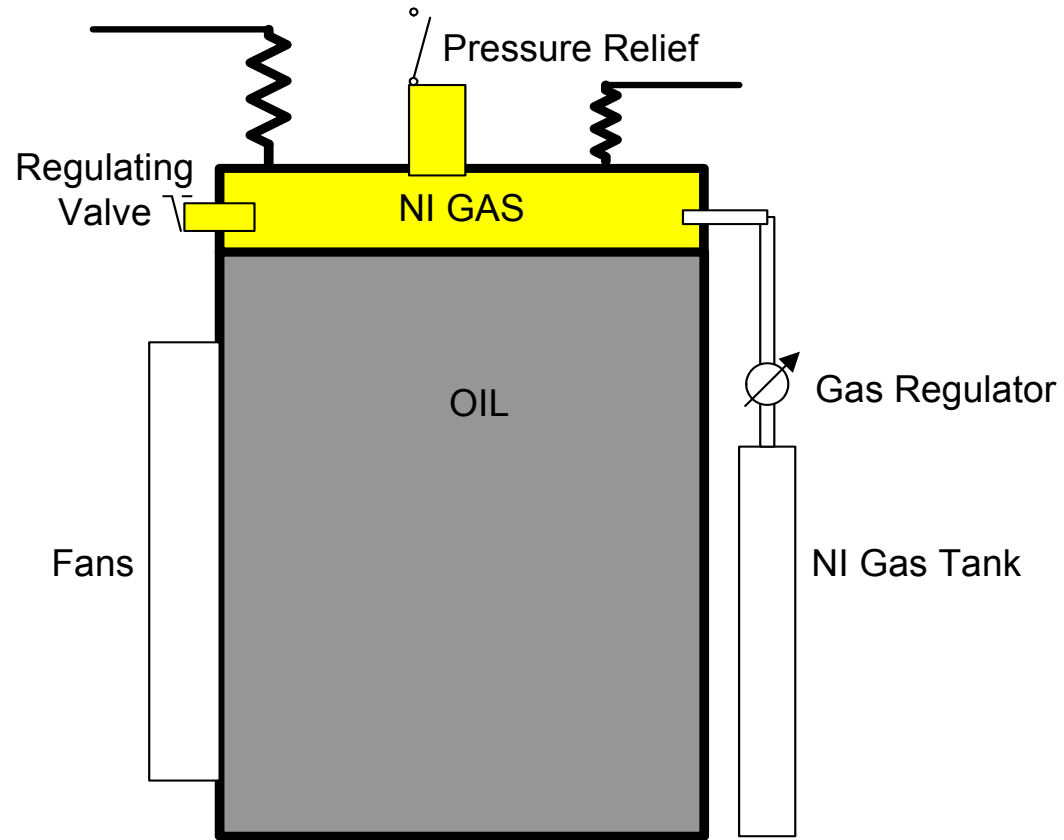
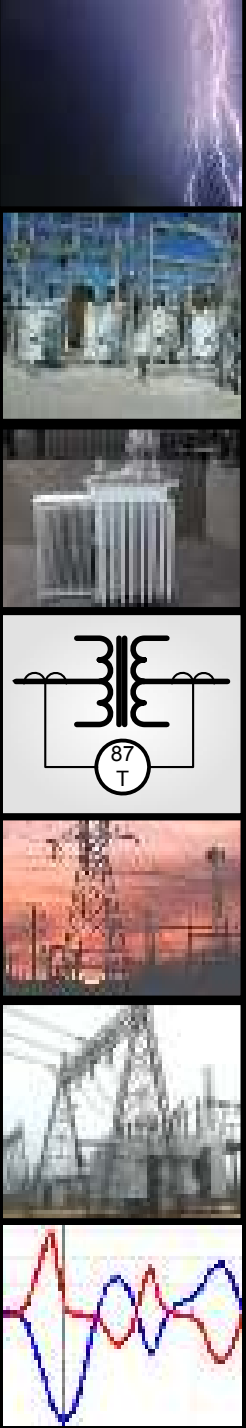

Transformer Ratings
OA/FA/FA

Basic Transformer Designs

Conservator Tank System

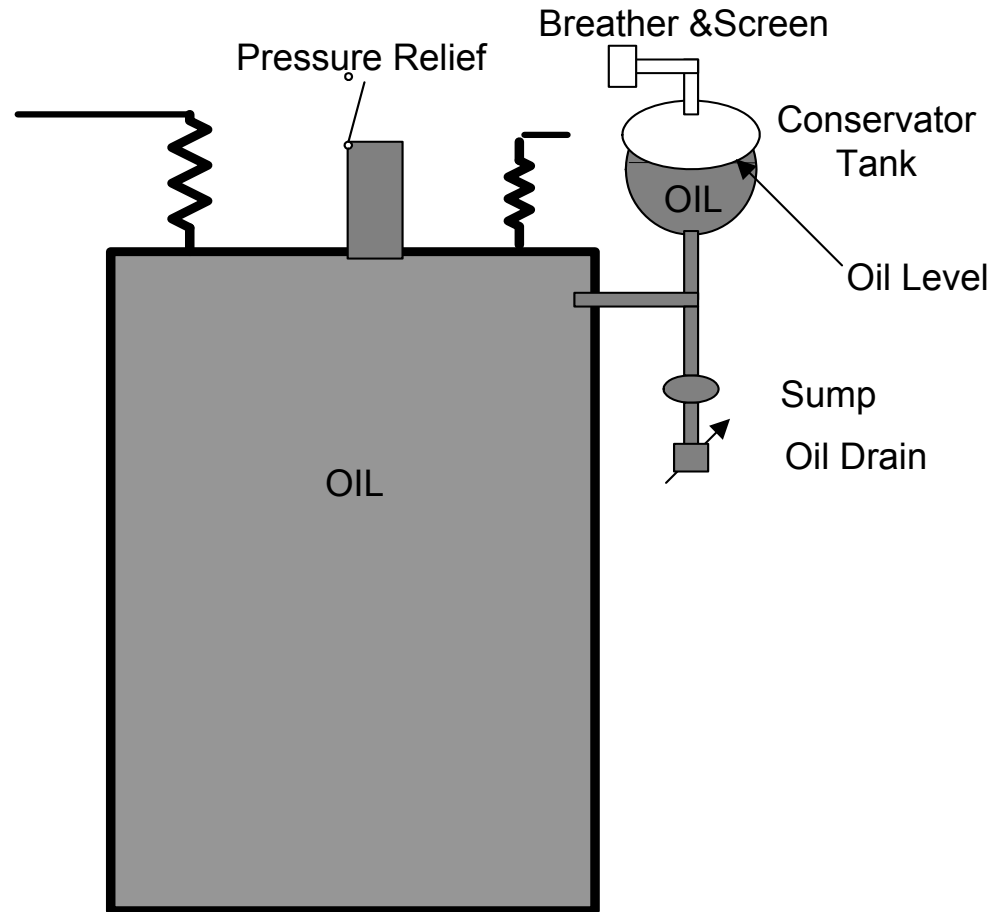

Transformer are Generally not
Forced Cooled

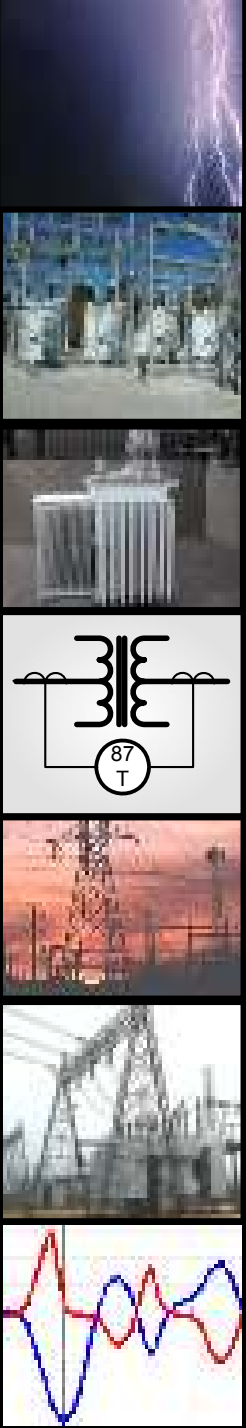

Basic Transformer Designs

Shell & Core

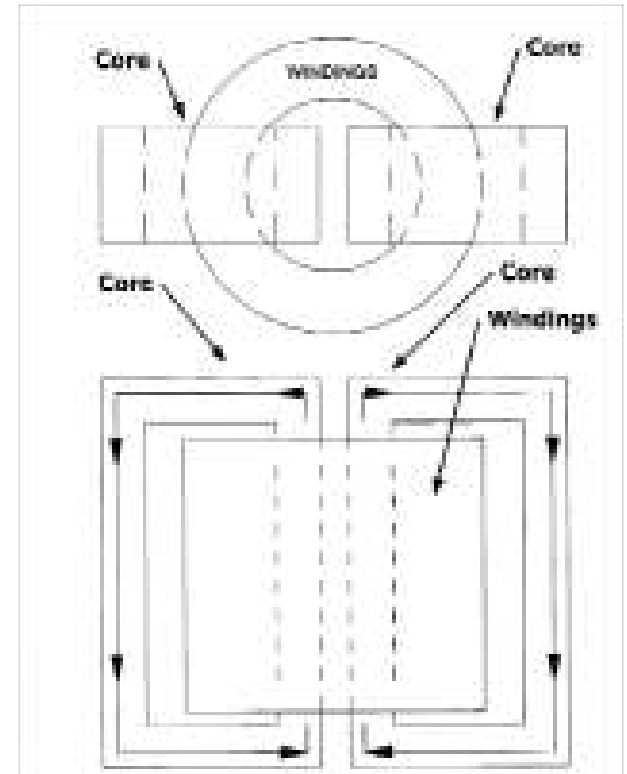
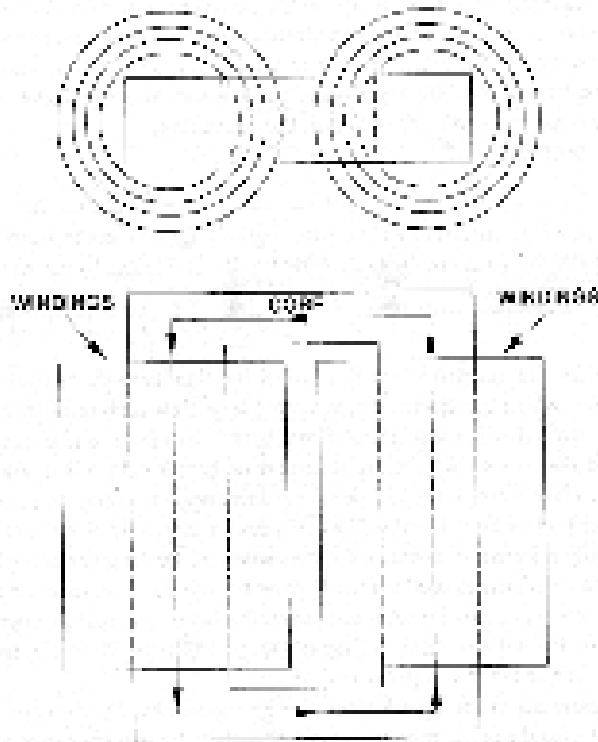

- **Core Form**

- *Single path for the magnetic circuit*
- *Less \$\$\$*

- **Shell Form**

- *Multiple paths for the magnetic circuit*
- *Better through-fault withstand*

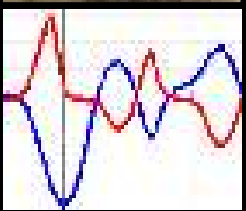
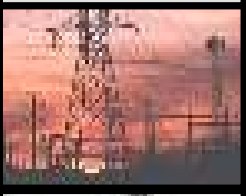
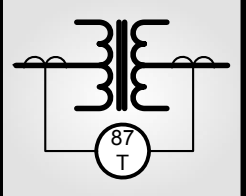

IEEE Devices used in Transformer Protection

- **24:** Overexcitation (V/Hz)
- **46:** Negative Sequence Overcurrent
- **49:** Thermal Overload
- **50:** Instantaneous Phase Overcurrent
- **50G:** Instantaneous Ground Overcurrent
- **50N:** Instantaneous Neutral Overcurrent
- **50BF:** Breaker Failure
- **51G:** Ground Inverse Time Overcurrent
- **51N:** Neutral Inverse Time Overcurrent
- **63:** Sudden Pressure Relay (Buccholtz Relay)
- **81U:** Underfrequency
- **87HS:** High-set Phase Differential (Unrestrained)
- **87T:** Transformer Phase Differential with Restraints
- **87GD:** Ground Differential (also known as “restricted earth fault”)

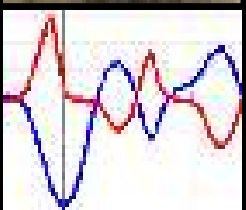
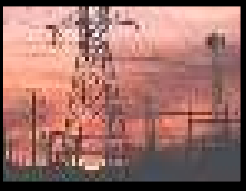
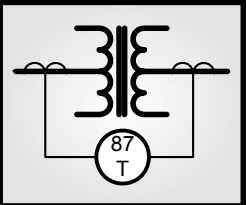

BASIC UTILITY SOLIDLY GROUND TRANSFORMER PROTECTIONS

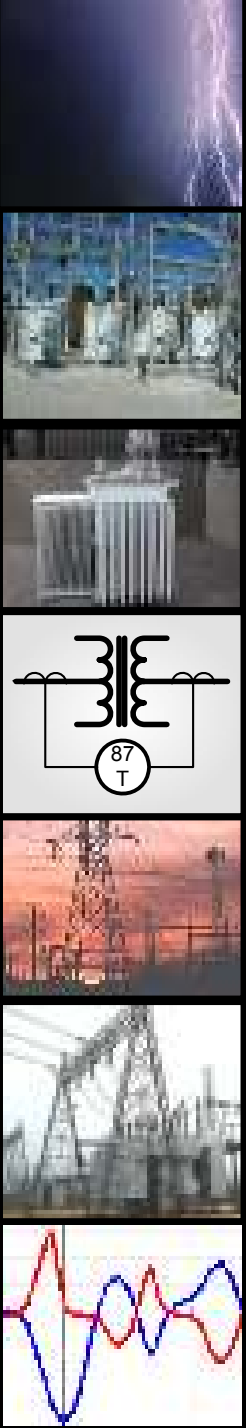
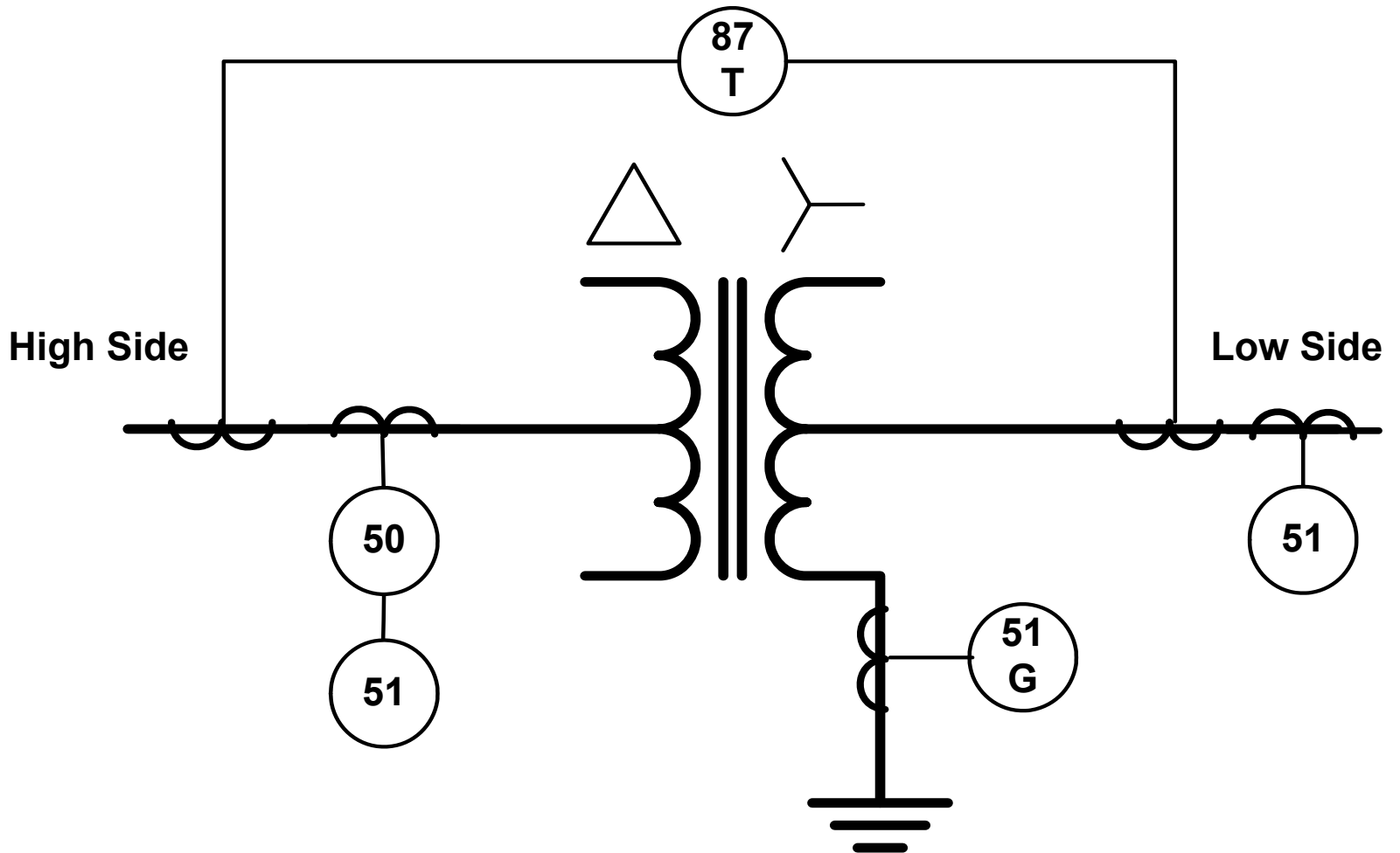

Basic Industrial Transformer Protection

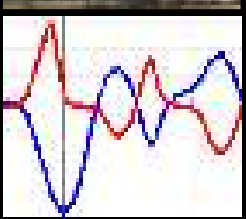
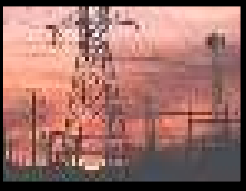
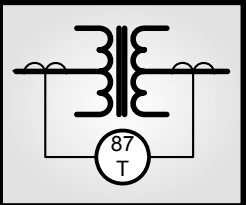
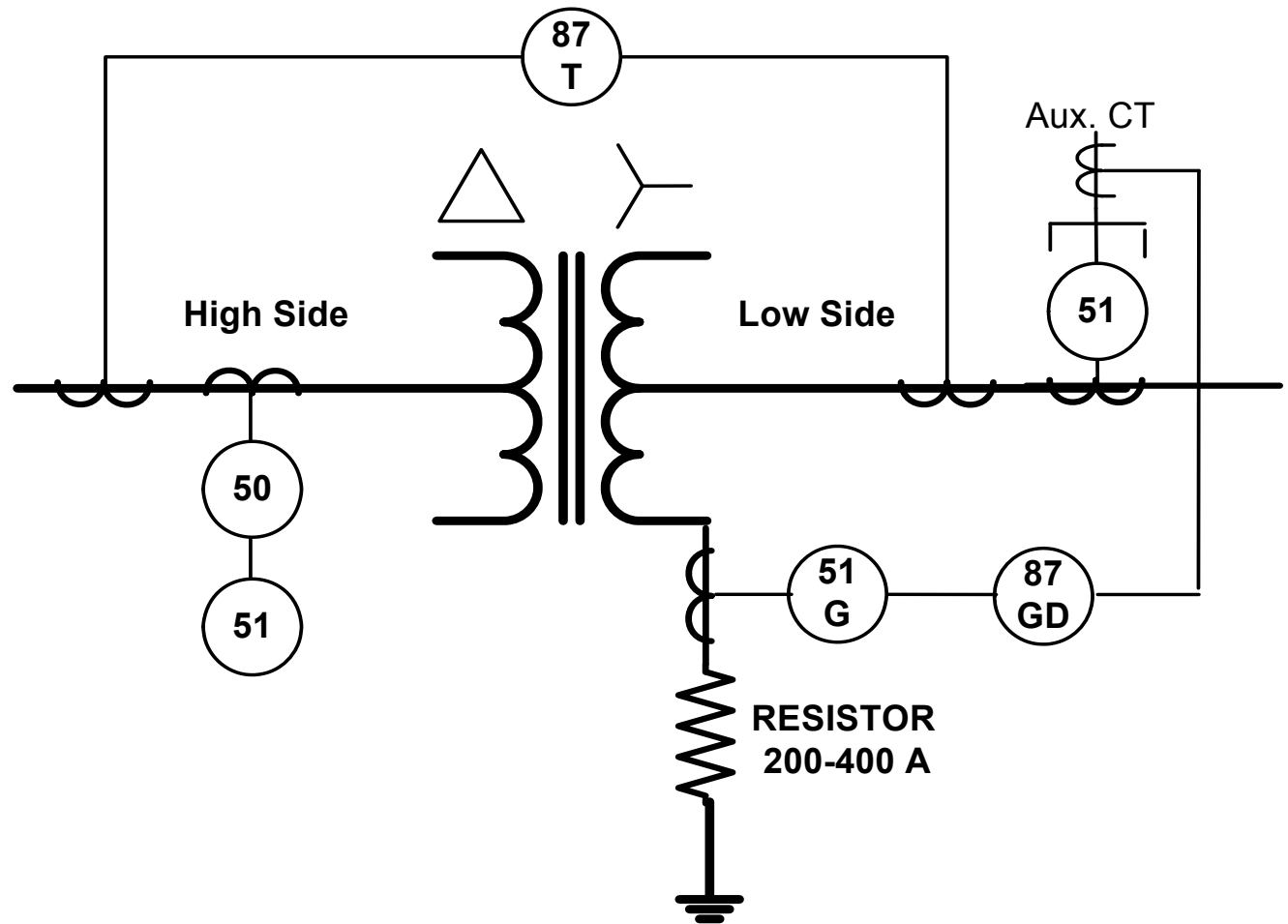

Types of Protection

Mechanical

- Accumulated Gases
 - Arcing by-products
- Pressure Relays
 - Arcing causing pressure waves in oil or gas space
- Thermal
 - Caused by overload, overexcitation, harmonics and geo magnetically induced currents
 - Hot spot temperature
 - Top Oil
 - LTC Overheating

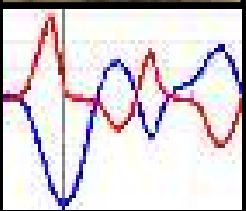
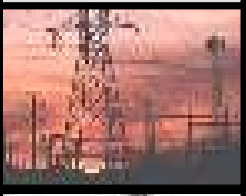
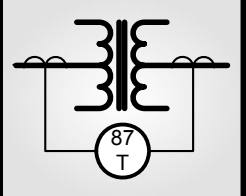

Sudden Pressure Relay (SPR) Protection

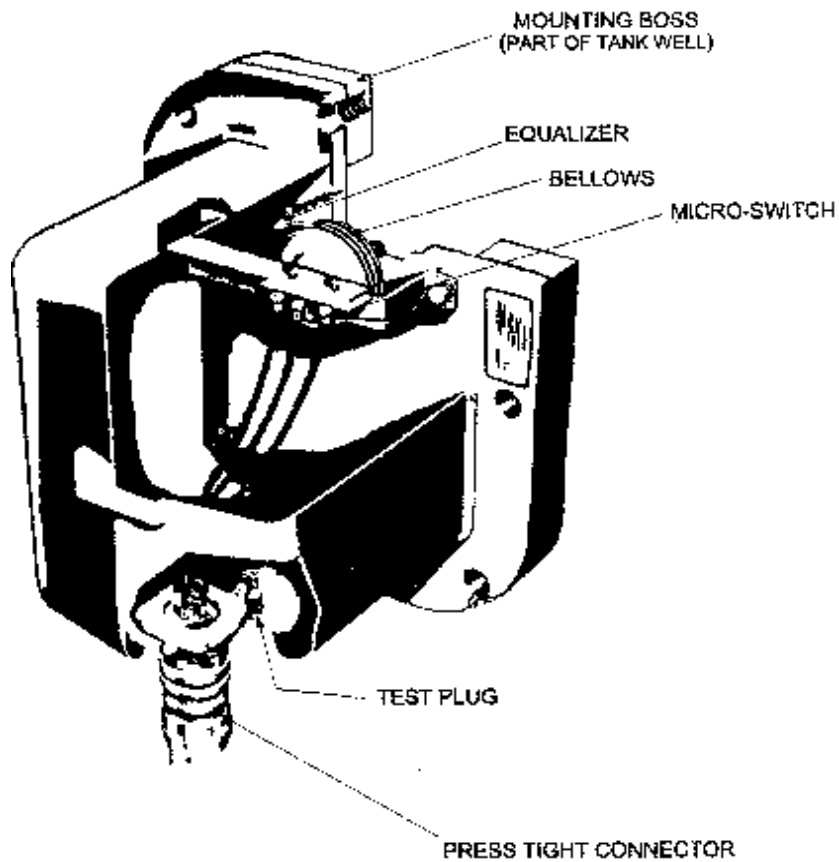

Sudden Pressure Relay

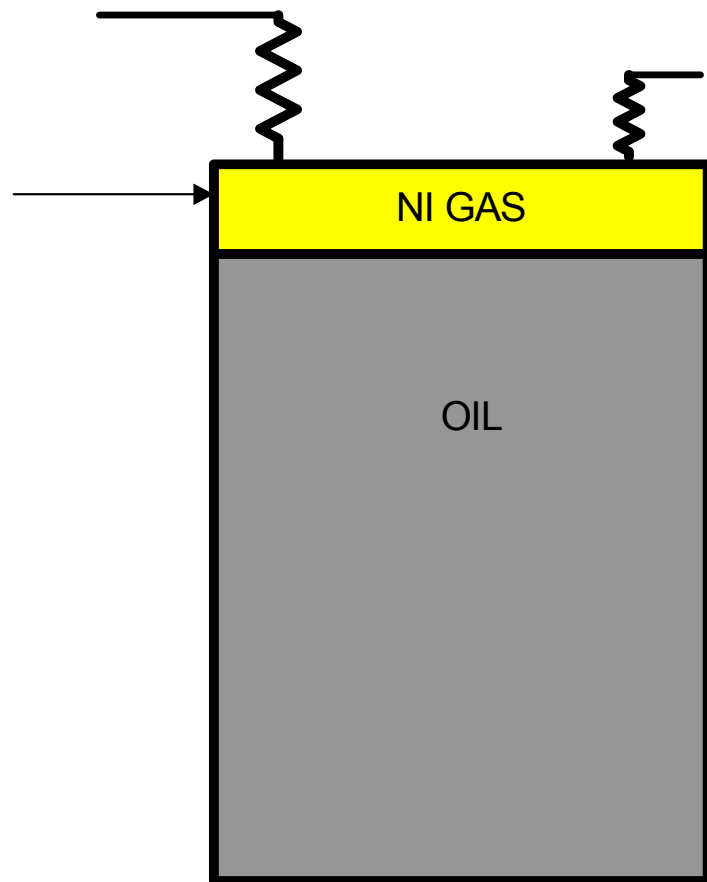

Transformer

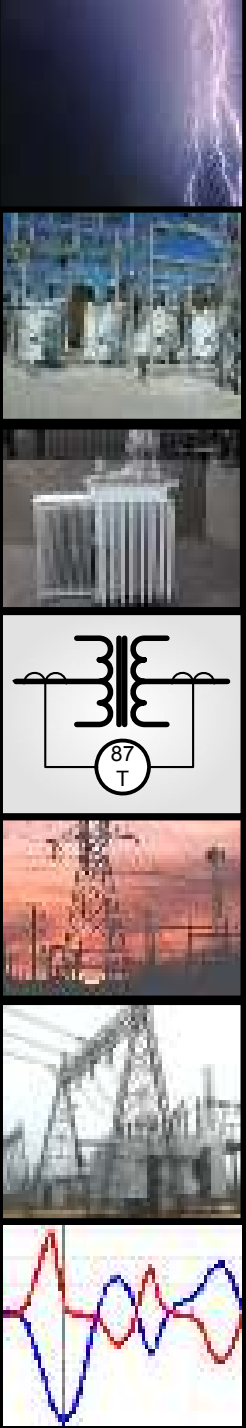

Transformer Thermal Monitoring

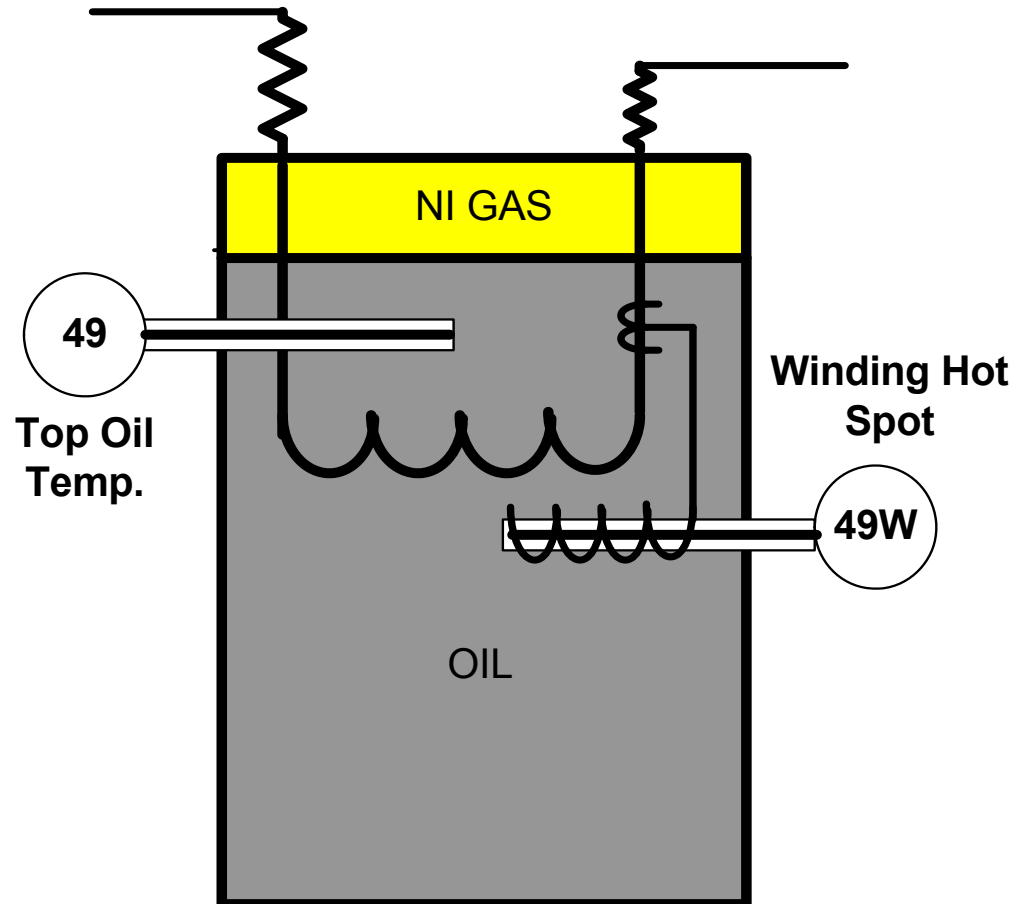
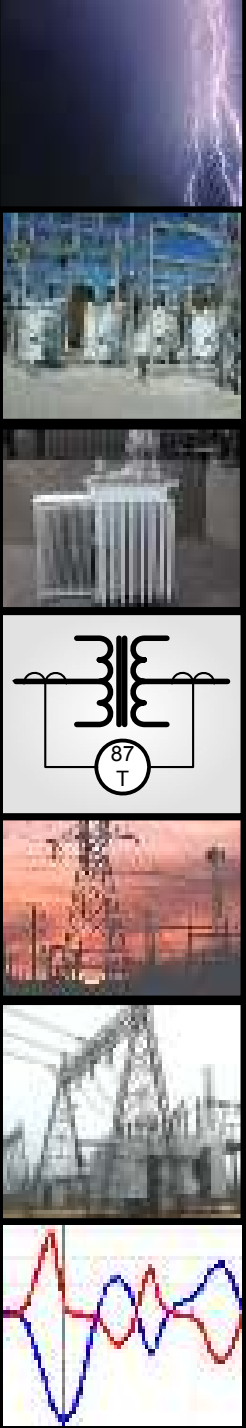

Types of Protection

Fuses

Small transformers (<10 MVA Solidly Grounded)

Short circuit protection only

Overcurrent Protection

High side

Through fault protection

Differential back-up protection for high side faults

Low side

System back up protection

Differential Protection

Phase Diff.

Ground Diff.

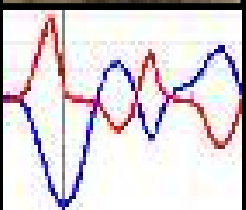
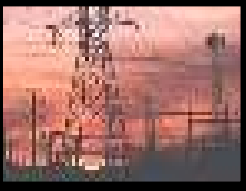
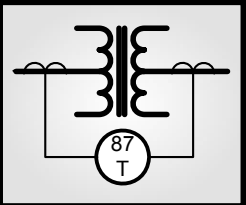

DELTA-WYE TRANSFORMERS UNDER FAULT CONDITIONS

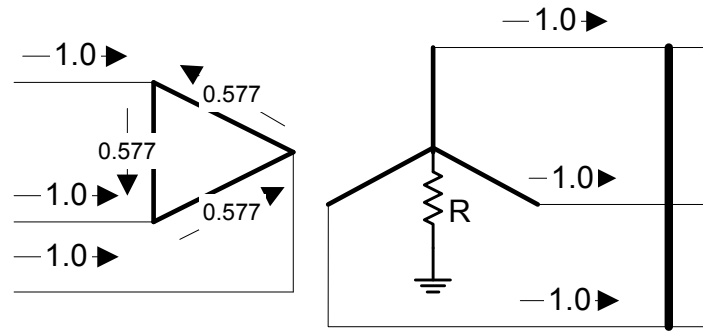

A) Three Phase Fault

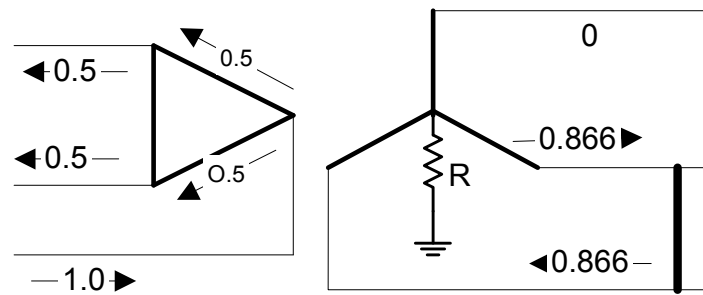

B) Phase to Phase Fault in pu of Three Phase Fault

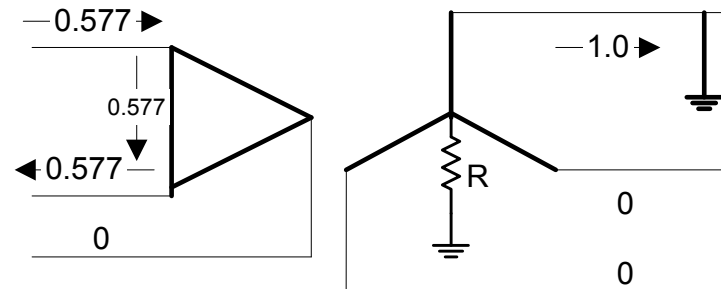

C) Line to Ground Fault

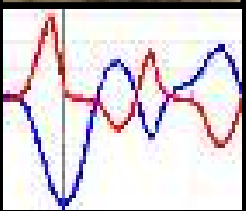
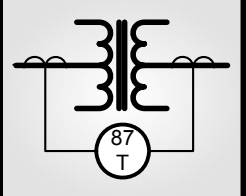

DELTA-WYE TRANSFORMERS LIMITATIONS OF FUSING

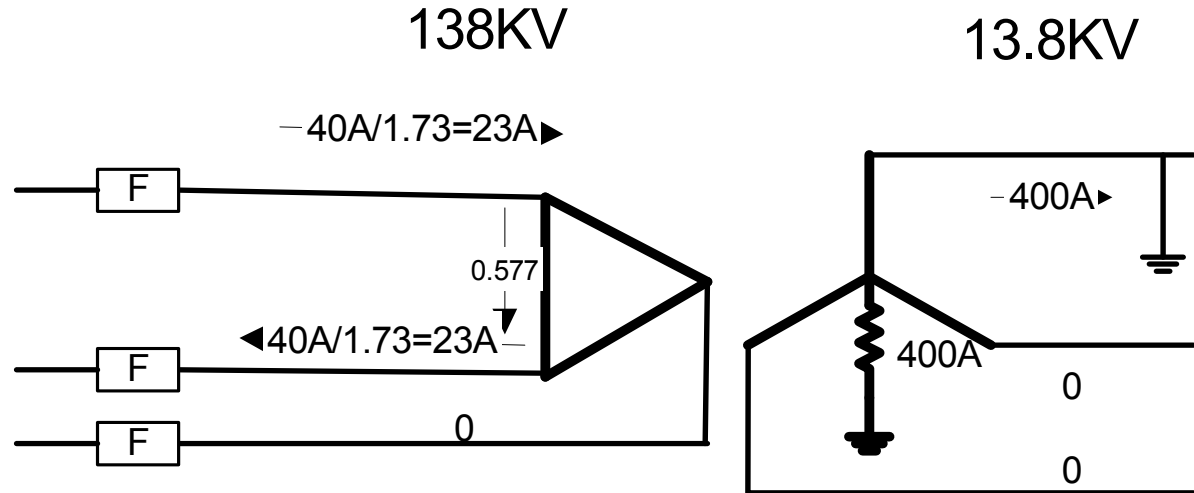

Line to Ground Fault 10 MVA 138/13.8KV

$$I_{FL} = 10,000/1.73 \times 138 = 42\text{A}$$

**WHEN FUSES ARE SIZED TO CARRY LOAD
THEY CAN'T DETECT A GROUND FAULT**

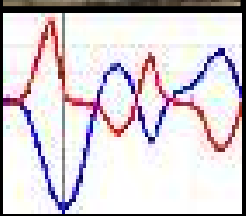
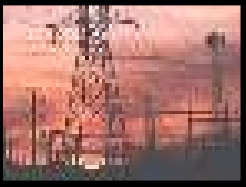
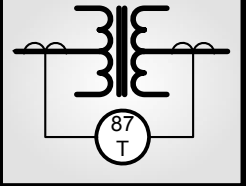

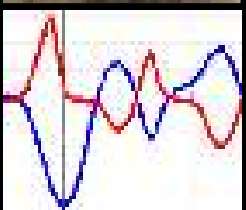
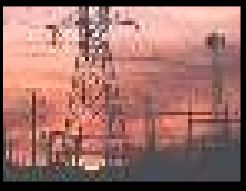
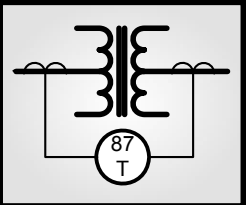

TRANSFORMER PHASING STANDARDS IEEE/ANSI & IEC

ANSI/IEEE PHASING STANDARD

- H1, H2, H3
 - Primary Bushings

- X1, X2, X3
 - Secondary Bushings



Wye-Wye	H1 and X1 at zero degrees
Delta-Delta	H1 and X1 at zero degrees
Delta-Wye	H1 lead X1 by 30 degrees
Wye-Delta	H1 lead X1 by 30 degrees

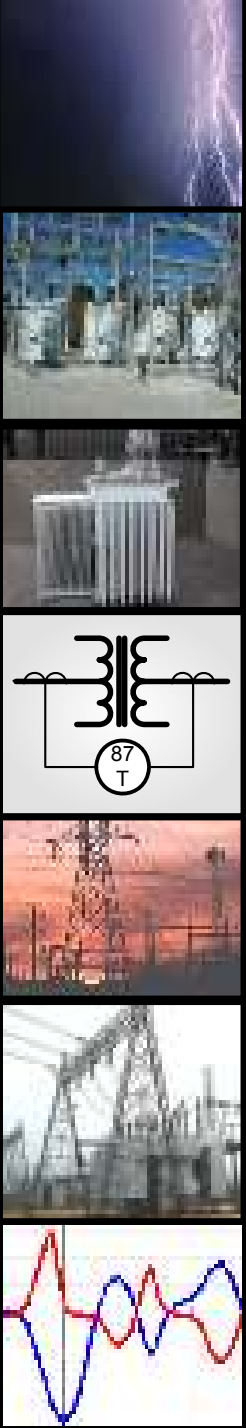

Angular Displacement - Development

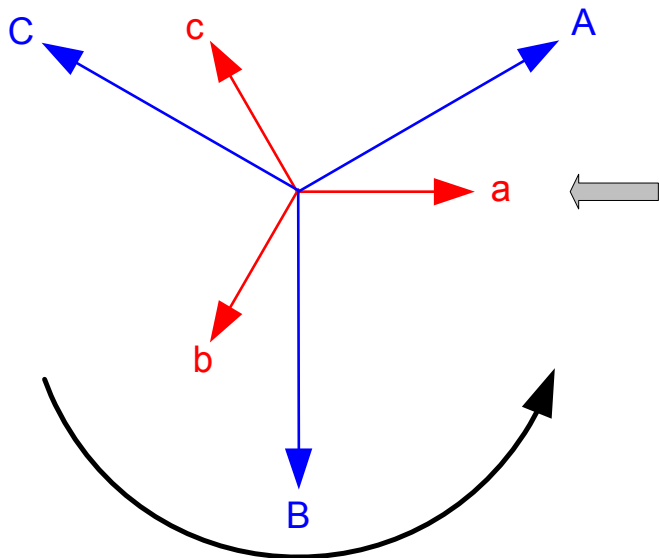
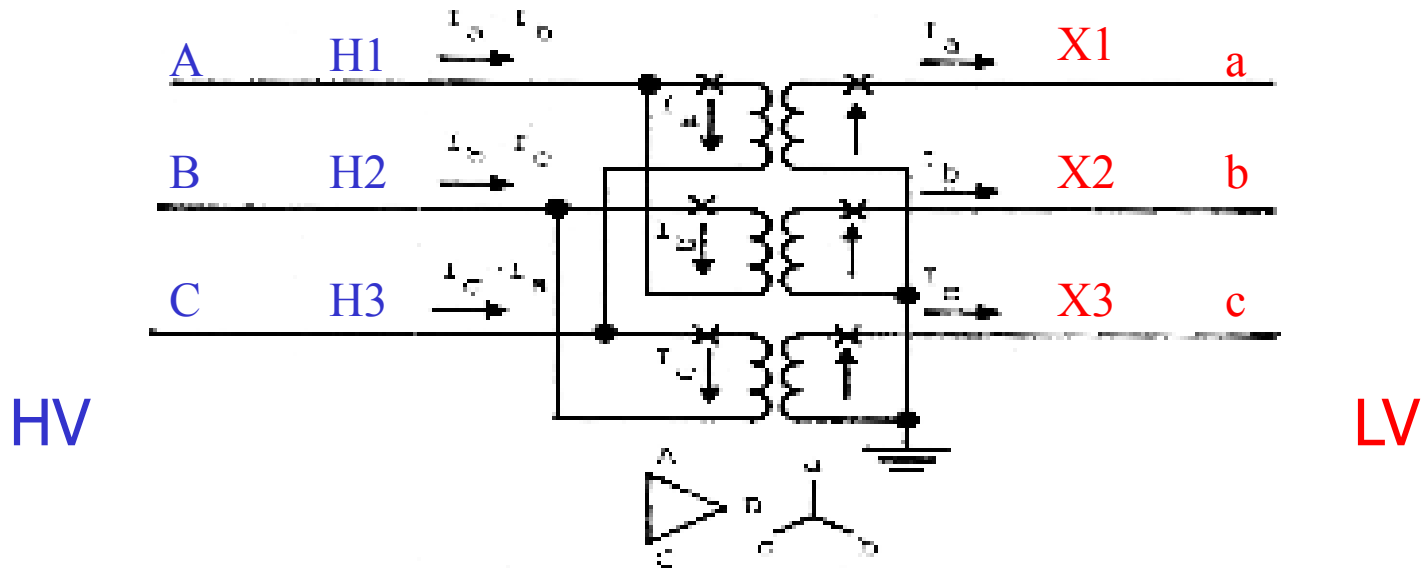

- H1 (A) leads X1 (a) by 30
- Currents on "H" bushings are delta quantities
- Can Describe as Delta AB ($I_a = I_a - I_b$)

Assume 1:1 transformer

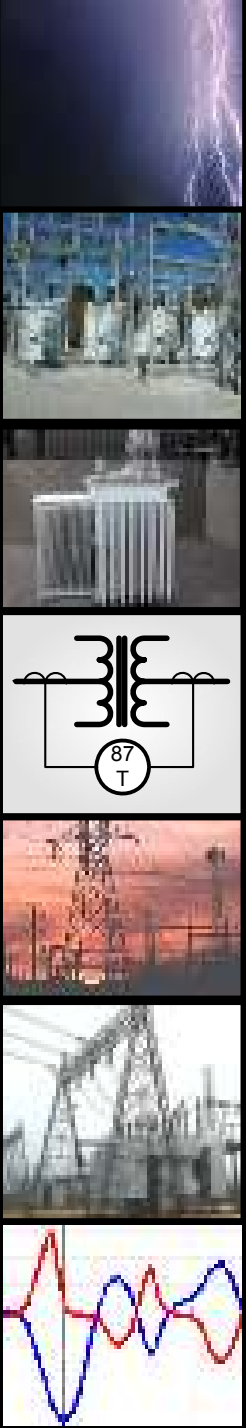

Angular Displacement - Development

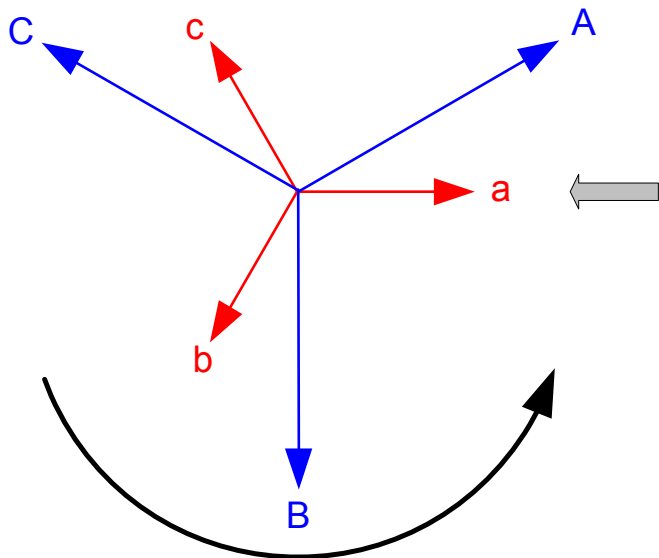
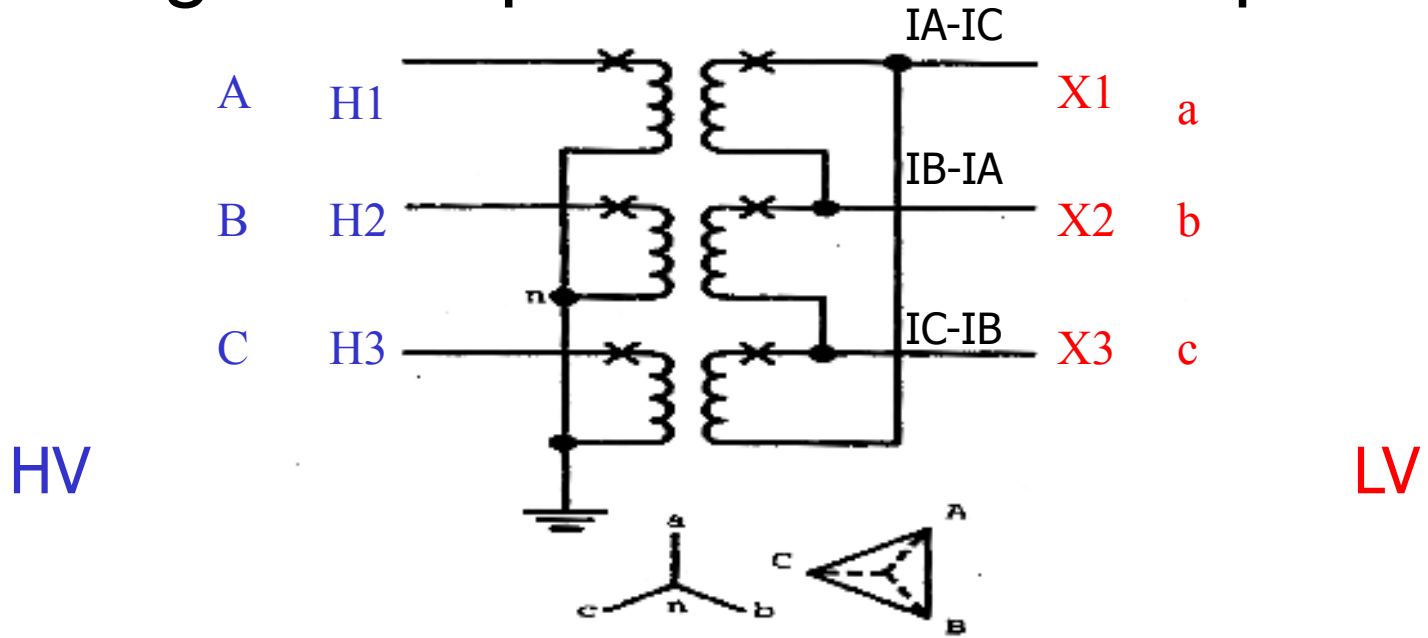

- H1 (a) leads X1 (A) by 30
- Currents on "X" bushings are delta quantities
- Can Describe as Delta AC ($I_a = I_A - I_C$)

Assume 1:1 transformer

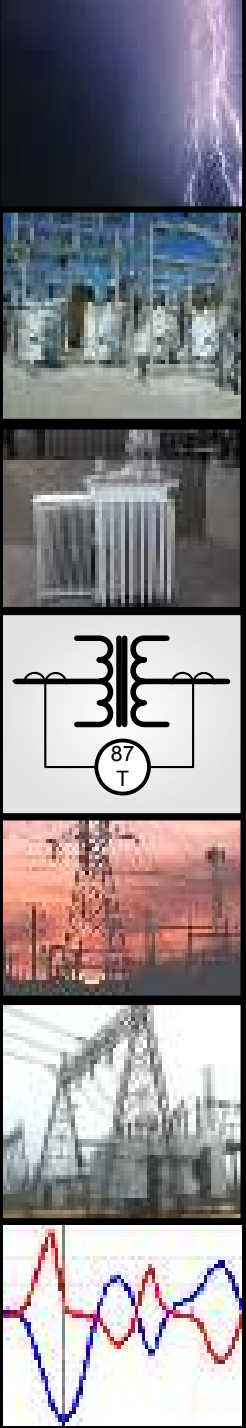

Transformer Phasing – IEC

Phasing Standard

Euro-designations use 30° increments of LAG from the X1 bushing to the H1 bushings

30° CLOCK

EXAMPLES

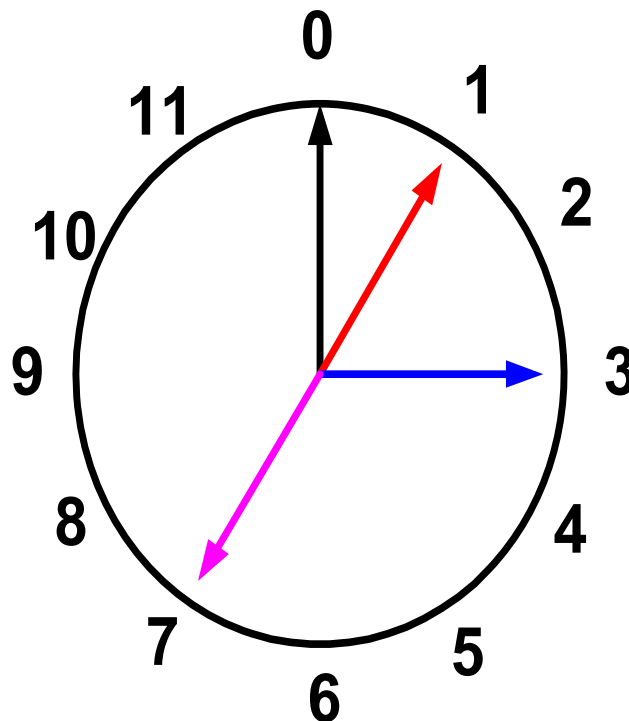

For Delta Primary Transformers:

1 = Dy1 = X lags H by 30°

3 = Dy3 = X lags H by 90°

7 = Dy 7 = X lags H by 210°

For Wye Primary Transformers:

1 = Yd1 = X lags H by 30°

3 = Yd3 = X lags H by 90°

7 = Yd7 = X lags H by 210°

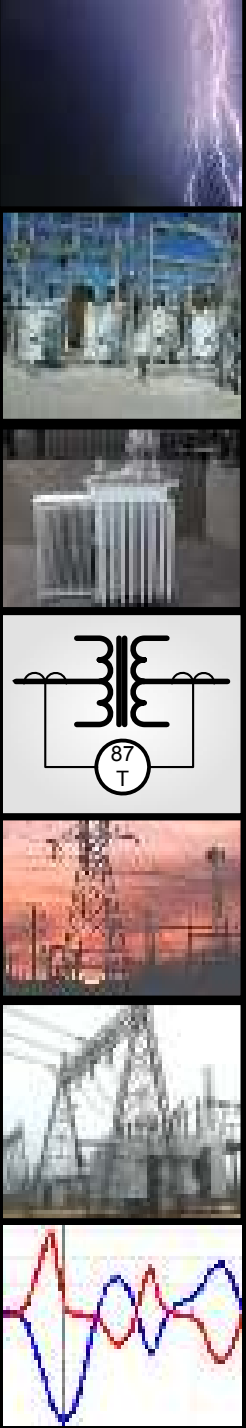

Transformer Phasing

Communicating Phasing To Digital Relays

- Major Source of Setting Error
- IEEE-ANSI – Can use Δ AB or Δ AC
- IEC – Need to Use 30° Clock
- CT's Can be Δ or Y
- **Solution: Let the Software Decide**

IEEE/ANSI Phasing Standard IEC Phasing Standard

Transformer/CT Connection: Standard Custom

Transformer Connection (W1)	Transformer Connection (W2)	Transformer Connection (W3)
Dab	Y	Y
C.T. Connection (W1)	C.T. Connection (W2)	Y
Y	Y	Dab
		Dac
		Inv. Y
		Inv. Dab

Zero Sequence Filter Enable: W1 W2 W3

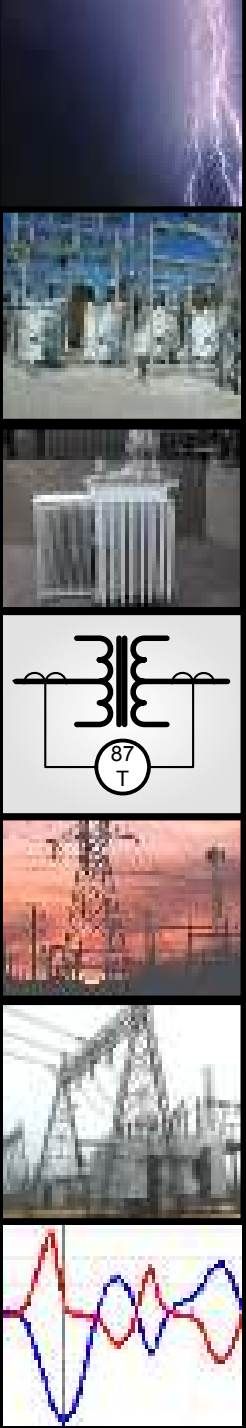

Angular Displacement

IEC Connection Description	Symbol	Backwith Standard Connection Description	Symbol
Yy0		yy	
Dd0		Dad Daa	
Yd1		Y Daa	
Yd11		Y Dab	
Dy1		Dab Y	
Dy11		Daa Y	
Ycb		Y Inverse Ccb	
Dc5		Daa Inverse Y	
Dd10		Daa Dab	
Dd2		Dab Custom	

*1

*1

*2

*2

- IEC (Euro) practice does not have a standard like ANSI
- Most common connection is Dy11 (low lead high by 30!)
- *Obviously observation of angular displacement is extremely important when paralleling transformers!*

*1 = ANSI std. @ 0°

*2 = ANSI std. @ X1 lag H1 by 30°, or "high lead low by 30 ° "

Winding Arrangements

- Wye-Wye
 - Conduct zero-sequence between circuits
 - Provides ground source for secondary circuit
- Delta-Delta
 - Blocks zero-sequence between circuits
 - Does not provide a ground source
- Delta-Wye
 - Blocks zero-sequence between circuits
 - Provides ground source for secondary circuit
- Wye-Delta
 - Blocks zero-sequence between circuits
 - Does not provide a ground source for secondary circuit

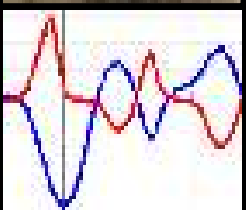
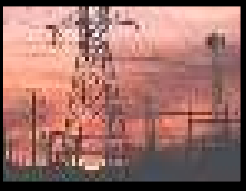
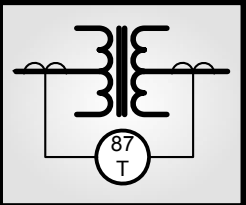

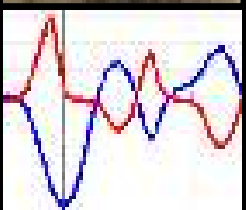
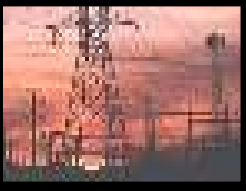
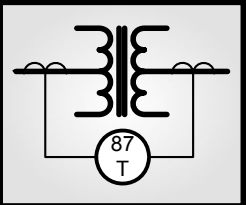

TRANSFORMER DIFFERENTIAL PROTECTION

Types of Protection

Electrical

- **Phase Differential**

- Applied with variable percentage slopes to accommodate CT saturation and CT ratio errors
- Applied with inrush and overexcitation restraints
- Set with at least a 15% pick up to accommodate CT performance
 - Class “C” CT; 10% at 20X rated
- If unit is LTC, add another 10%
- May not be sensitive enough for all faults (low level, ground faults near neutral, resistor grounded transformers)

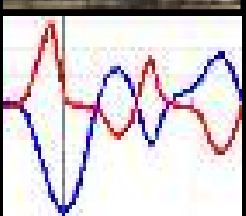
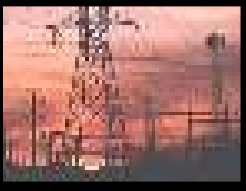
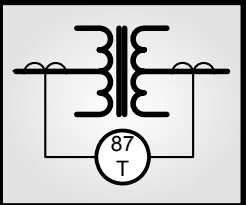

Basic Differential Relay

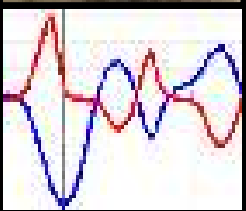
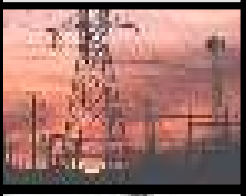
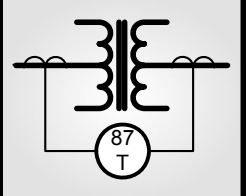
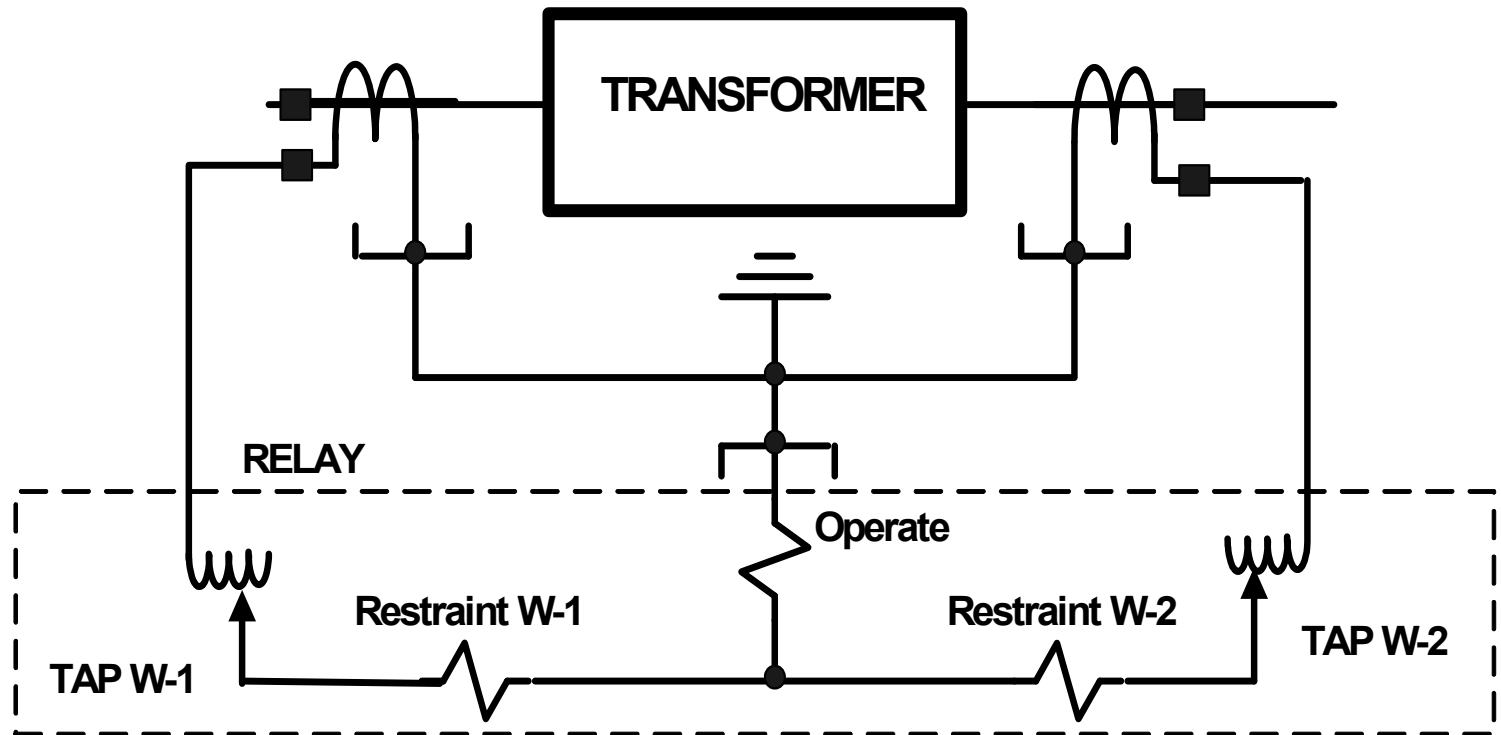

Basic Differential Relay

External Fault

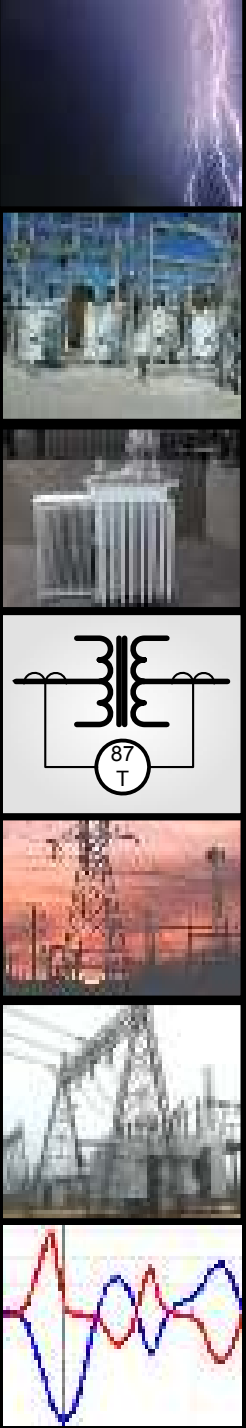
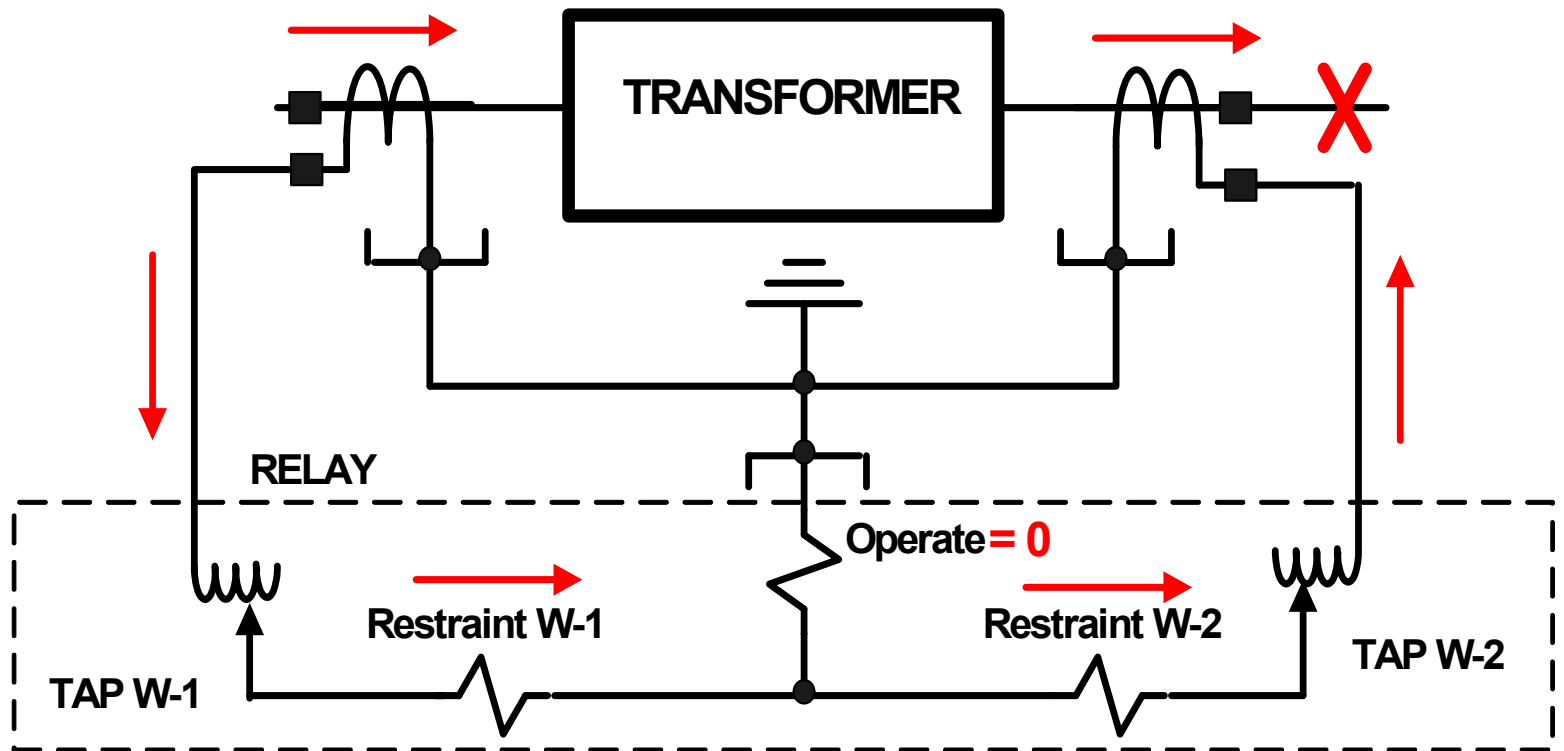

Basic Differential Relay

Internal Fault

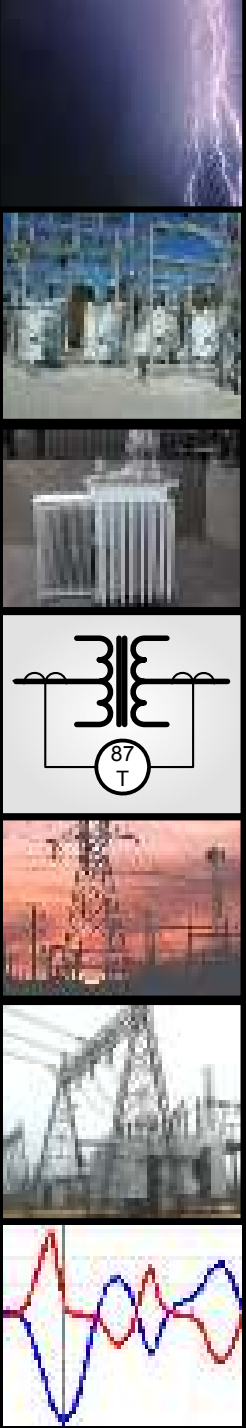
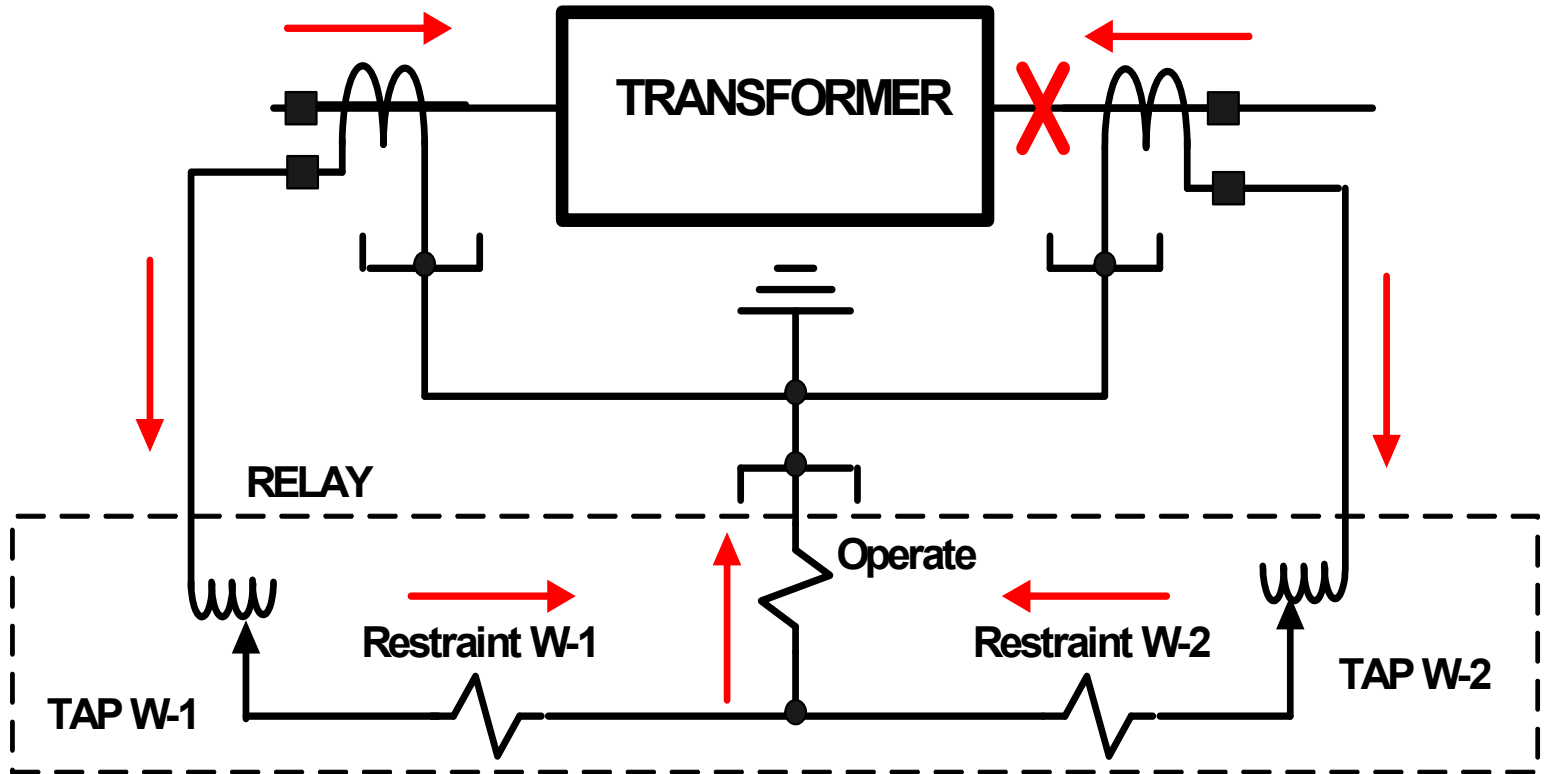

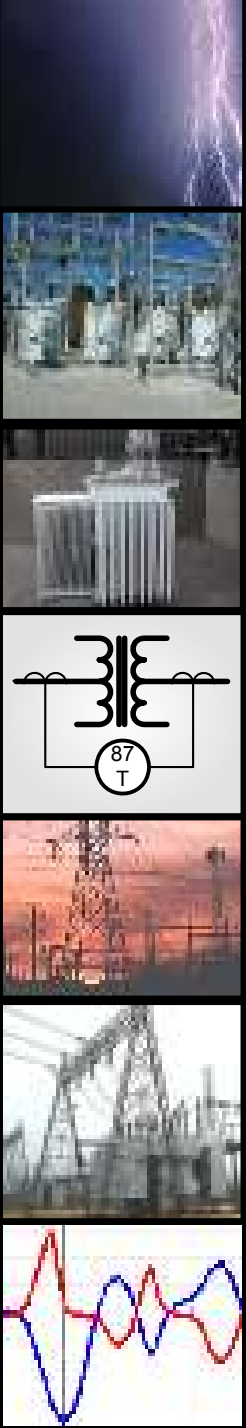

Typical Phase Differential Characteristic – Percentage Slope Concept

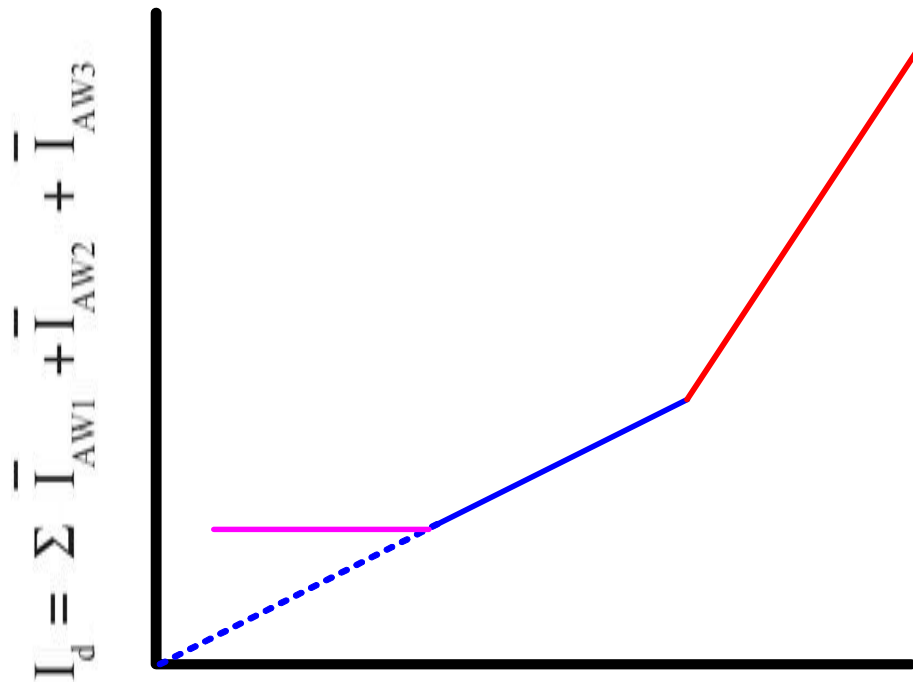
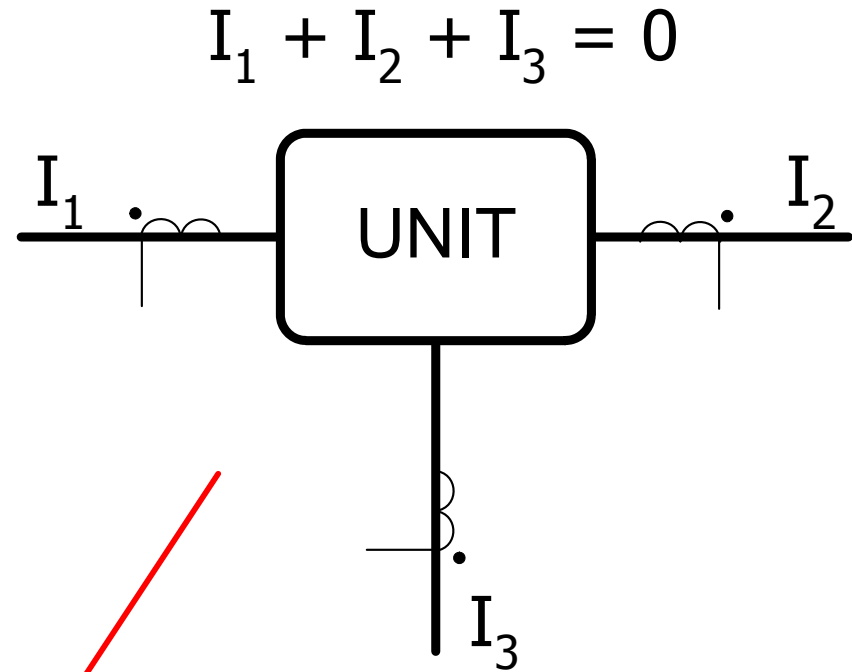

$$I_R = \frac{\sum |I_{AW1}| + |I_{AW2}| + |I_{AW3}|}{2}$$

Unique Issues Applying to Transformer Differential Protection

- ***CT ratio*** caused current mismatch
- ***Transformation ratio*** caused current mismatch (fixed taps)
- ***LTC induced current mismatch***
- ***Delta-wye transformation*** of currents
 - Vector group and current derivation issues
- ***Zero-sequence current elimination*** for external ground faults on wye windings
- ***Inrush phenomena*** and its resultant current mismatch

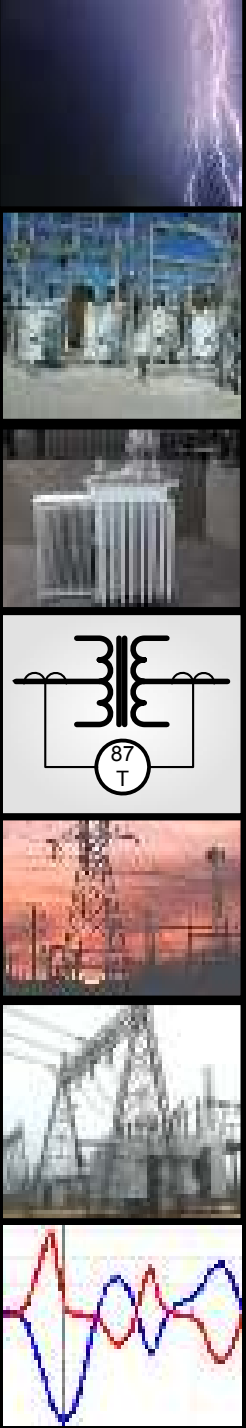

Classical Differential Compensation

- CT ratios must be selected to account for:
 - Transformer ratios
 - If delta or wye connected CTs are applied
 - Delta increases ratio by 1.73
- Delta CTs must be used to filter zero-sequence current on wye transformer windings

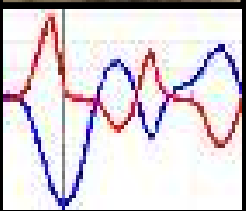
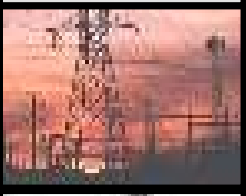
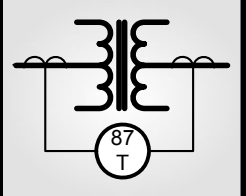

Unique Issues Applying to Transformer Differential Protection

- ***Harmonic content availability*** during inrush period due to point-on-wave switching (especially with newer transformers)
- ***Overexcitation phenomena*** and its resultant current mismatch
- ***Internal ground fault sensitivity*** concerns
- ***Switch onto fault*** concerns
- ***CT saturation, remnance and tolerance***

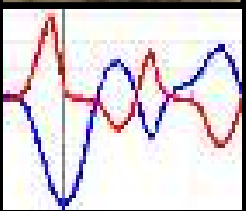
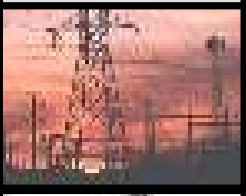
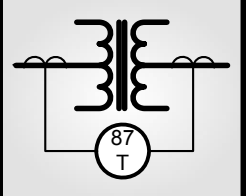

Classical Electro-Mechanical Differential Compensation

PRI. (H)

SEC. (X)

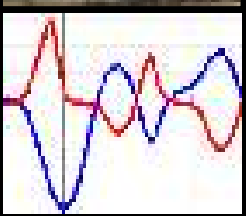
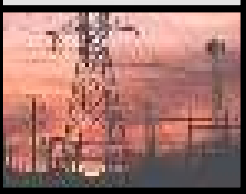
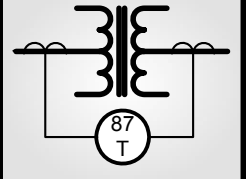
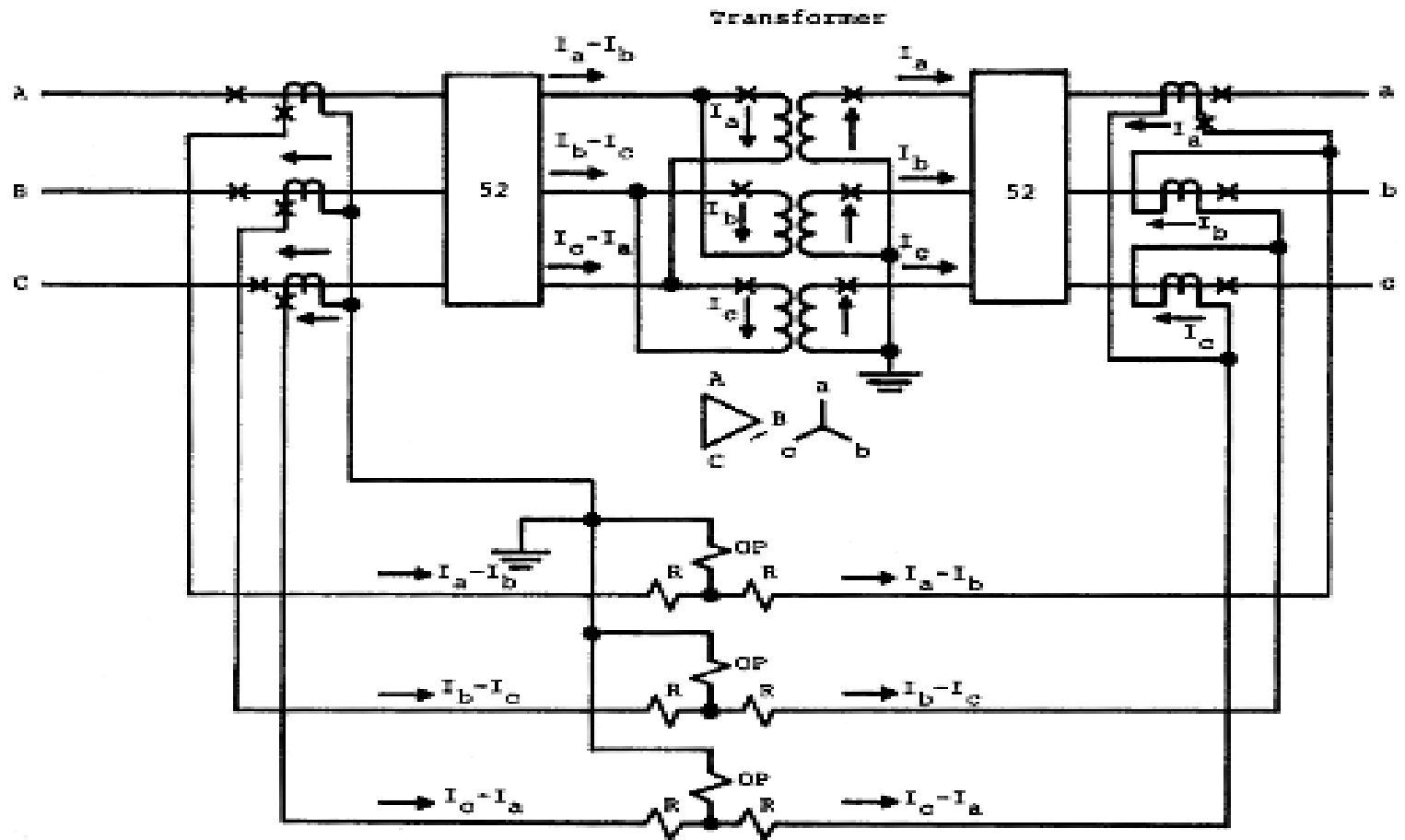

Digital Relay Application

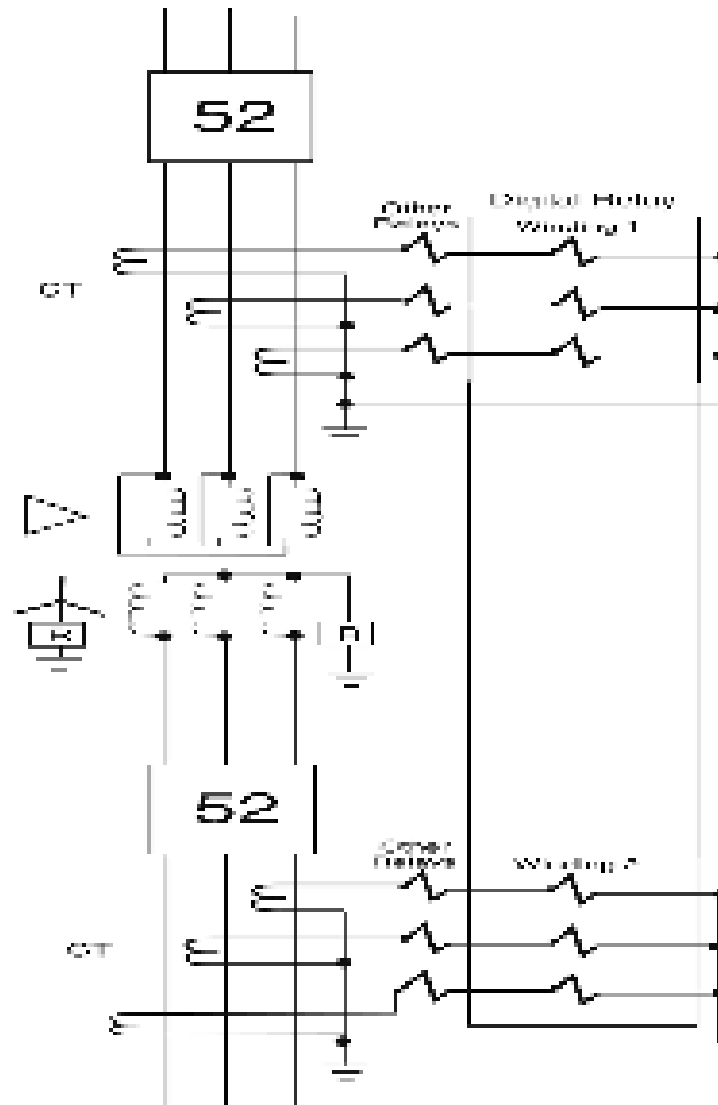
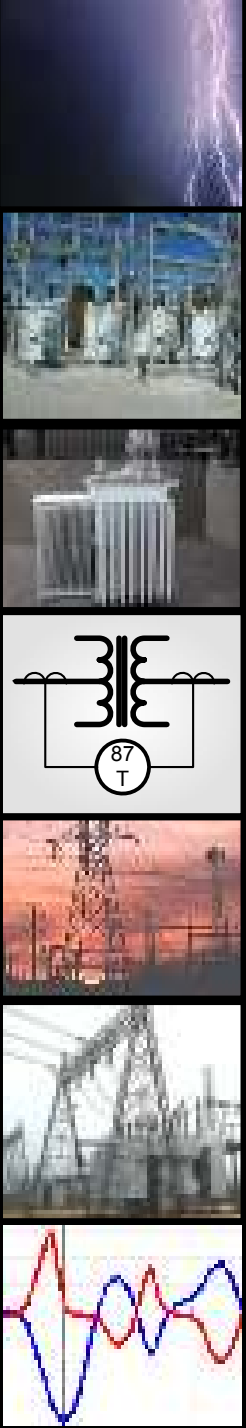

Compensation in Digital Relays

- Transformer ratio
- CT ratio
- Vector quantities
 - Which vectors are used
 - Where the 1.73 factor ($\sqrt{3}$) is applied
 - When examining line to line quantities on delta connected transformer windings and CT windings
- Zero-sequence current filtering for wye windings so the differential quantities do not occur from external ground faults

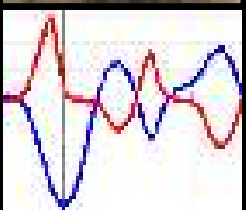
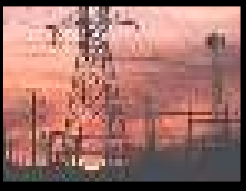
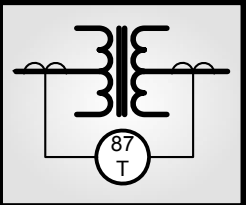

Digital Relay Application

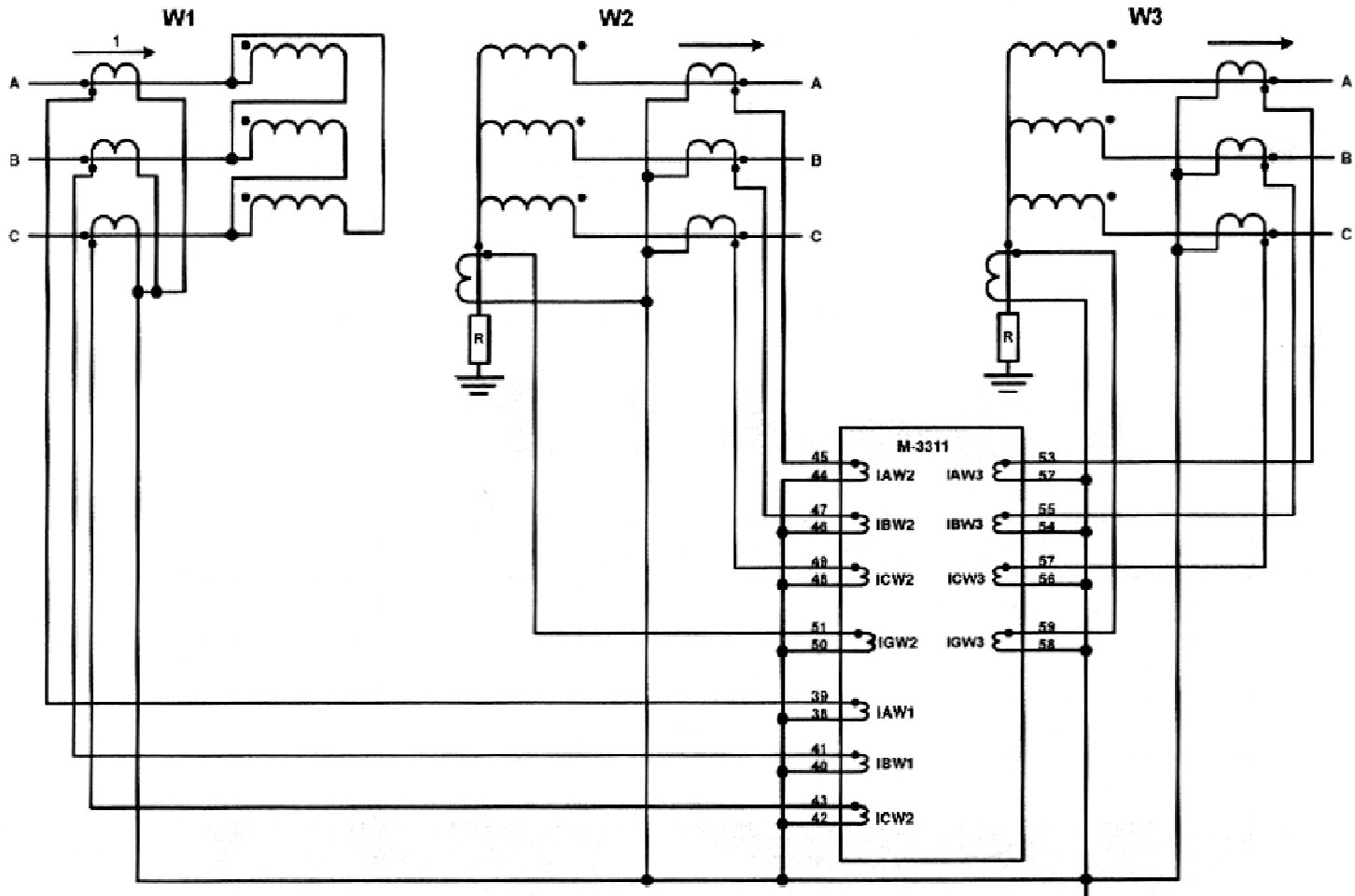

All wye CTs shown, can retrofit legacy delta CT applications

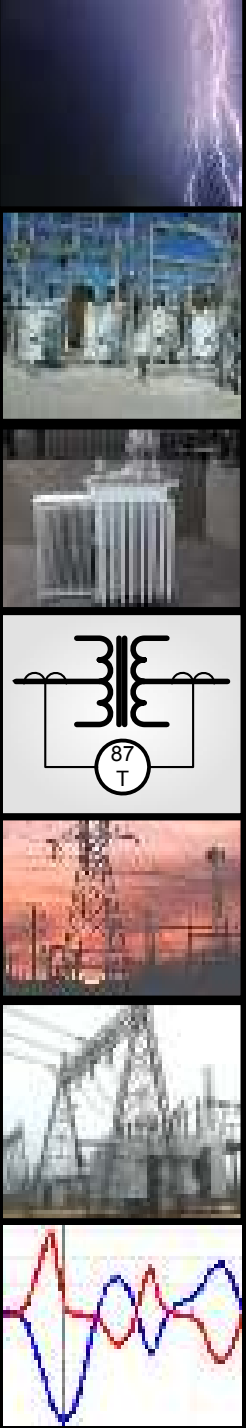

Benefits of Wye CTs

- Phase segregated line currents
 - Individual line current oscillography
 - Currents may be easily used for overcurrent protection and metering
 - Easier to commission and troubleshoot
 - Zero sequence elimination performed by calculation
 - **BUT IS IT WORTH ALL THE RE-WIRING IN RETRO-FIT APPLICATIONS ?**

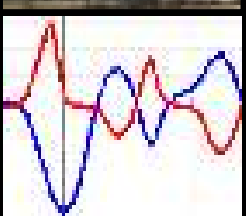
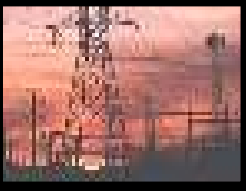
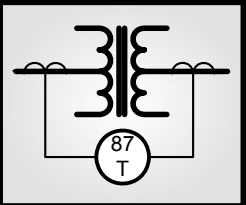

Typical Applications

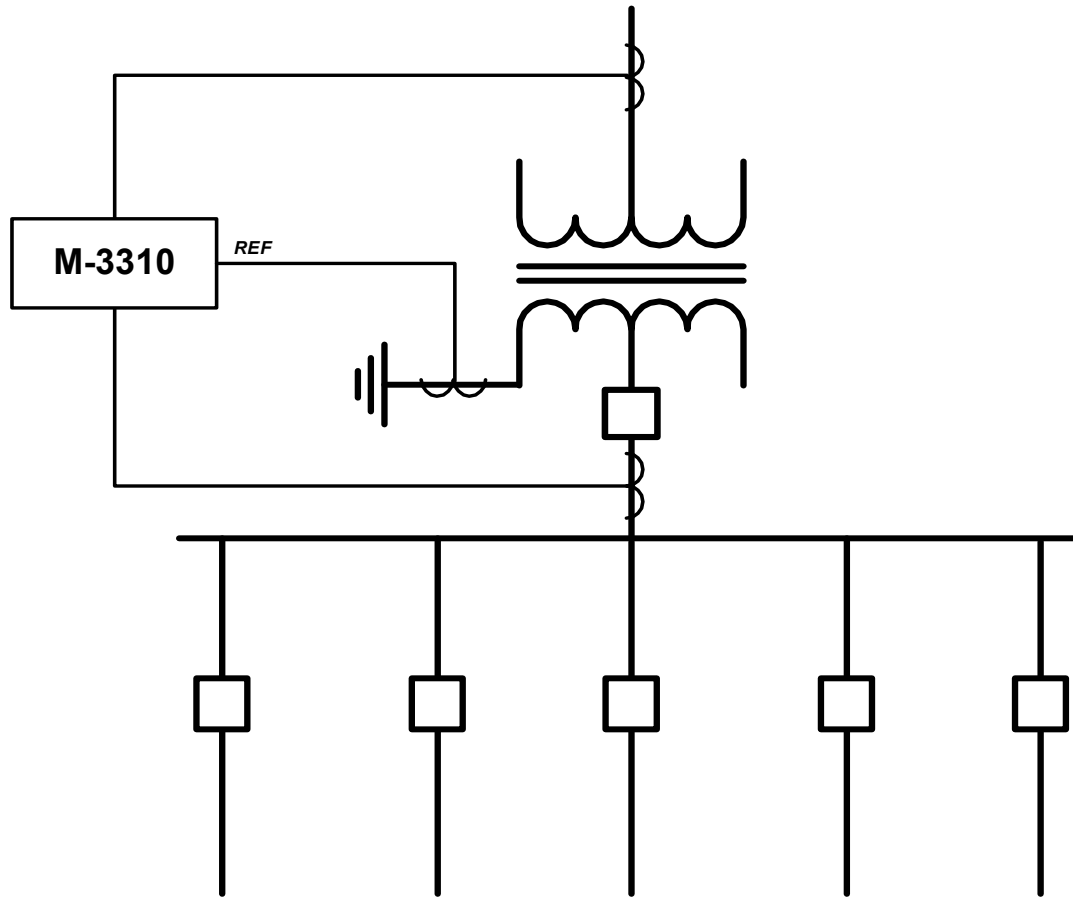

- Two winding transformer, with Neutral Input

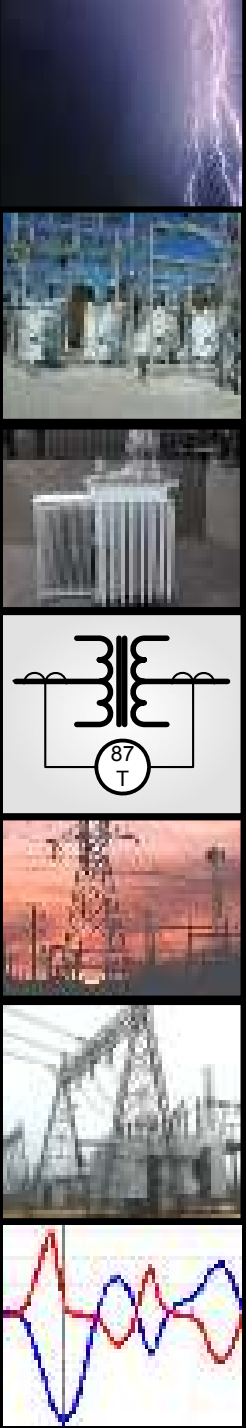

Typical Applications

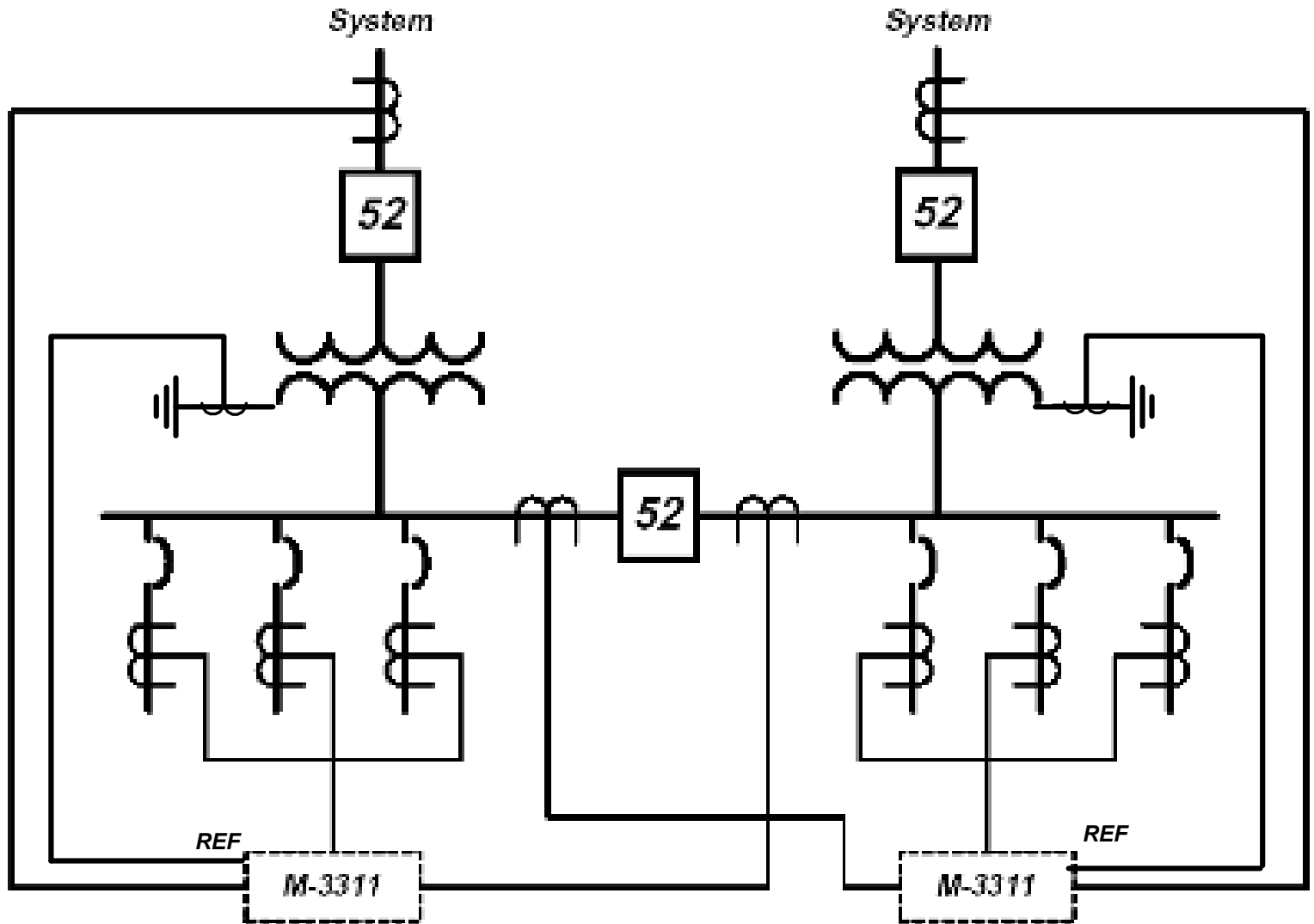

- Main-Tie-Main Substation

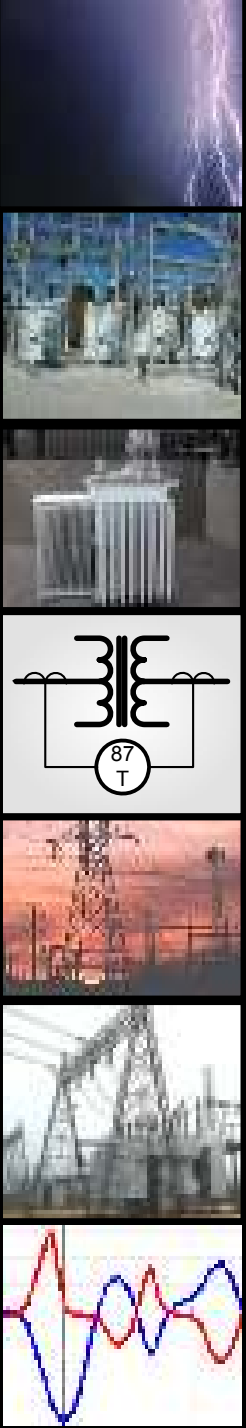

Typical Applications

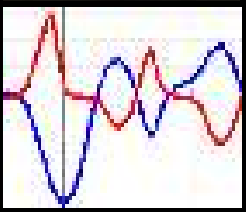
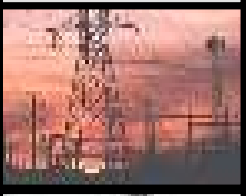
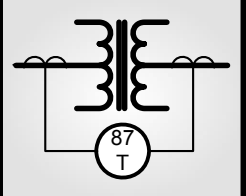

- Generator unit differential wrap

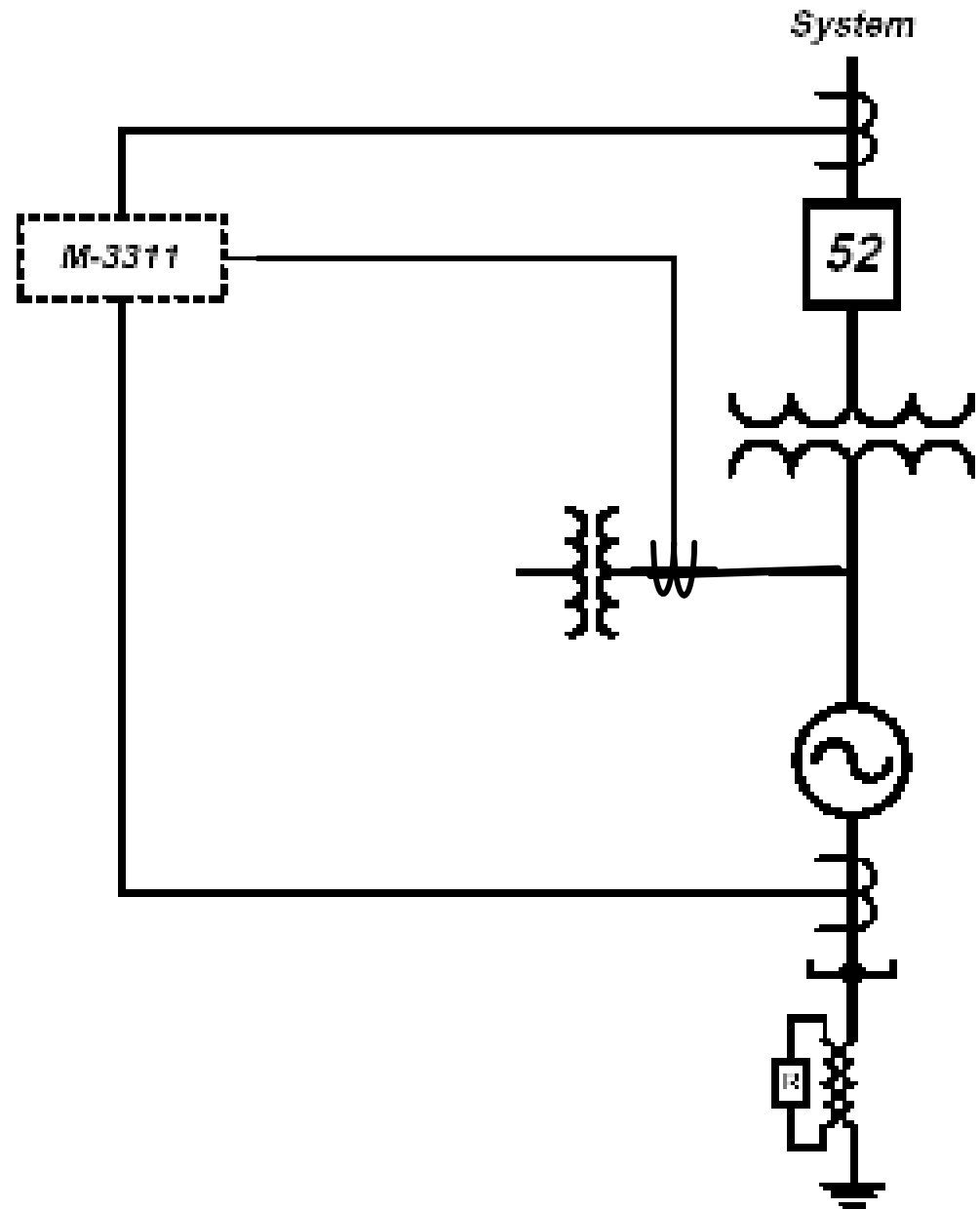

Inrush Restraint

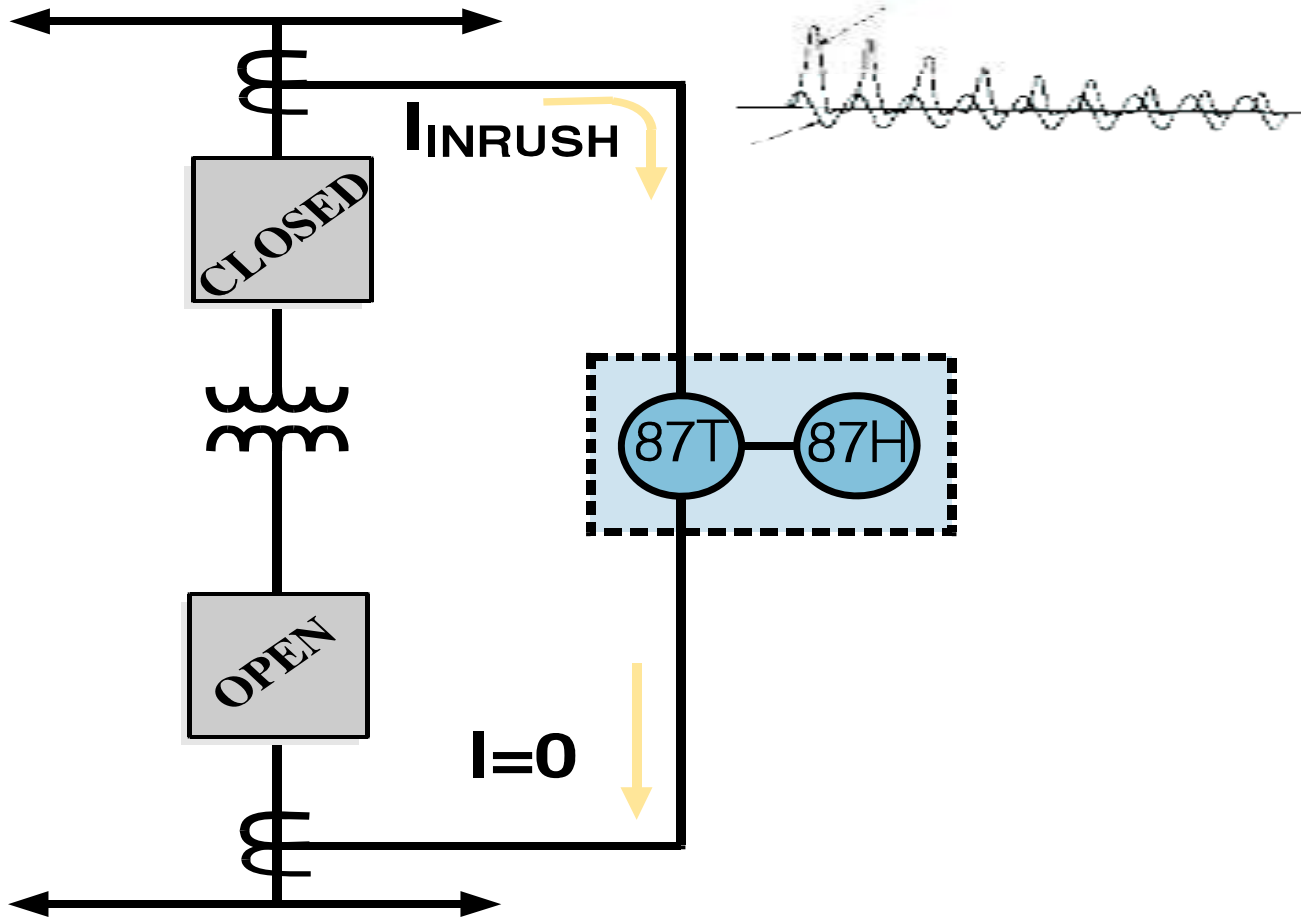
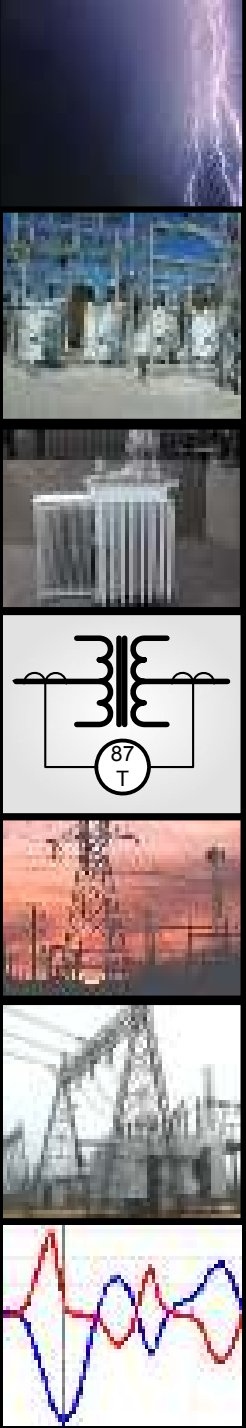

Advanced Element Design: 87T

- Inrush Detection and Restraint
 - 2nd harmonic restraint has been employed for years
 - “Gap” detection has also been employed
 - As transformers are designed to closer tolerances, both 2nd harmonic and low current gaps in waveform have decreased
 - If 2nd harmonic restraint level is set too low, differential element may be blocked for internal faults with CT saturation (with associated harmonics generated)

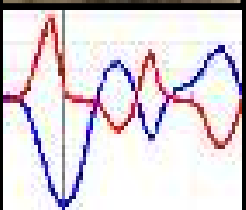
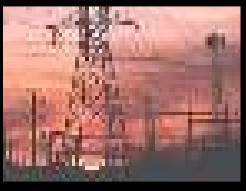
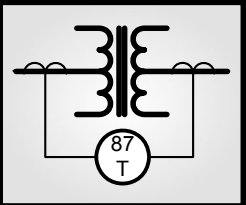

Advanced Element Design: 87T

- Inrush Detection and Restraint
 - 4th harmonic is also generated during inrush
 - Odd harmonics are not as prevalent as Even harmonics during inrush
 - Odd harmonics more prevalent during CT saturation
 - Use 4th harmonic and 2nd harmonic together
 - M-3310/M-3311 relays use RMS sum of the 2nd and 4th harmonic as inrush restraint
 - Result: Improved security while not sacrificing reliability

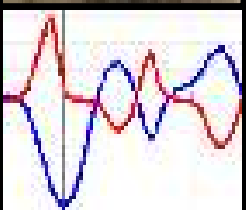
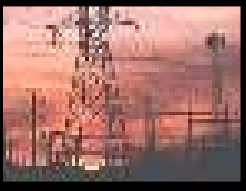
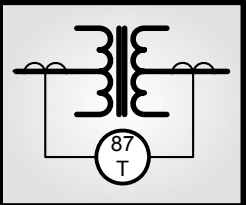

Advanced Element Design: 87T

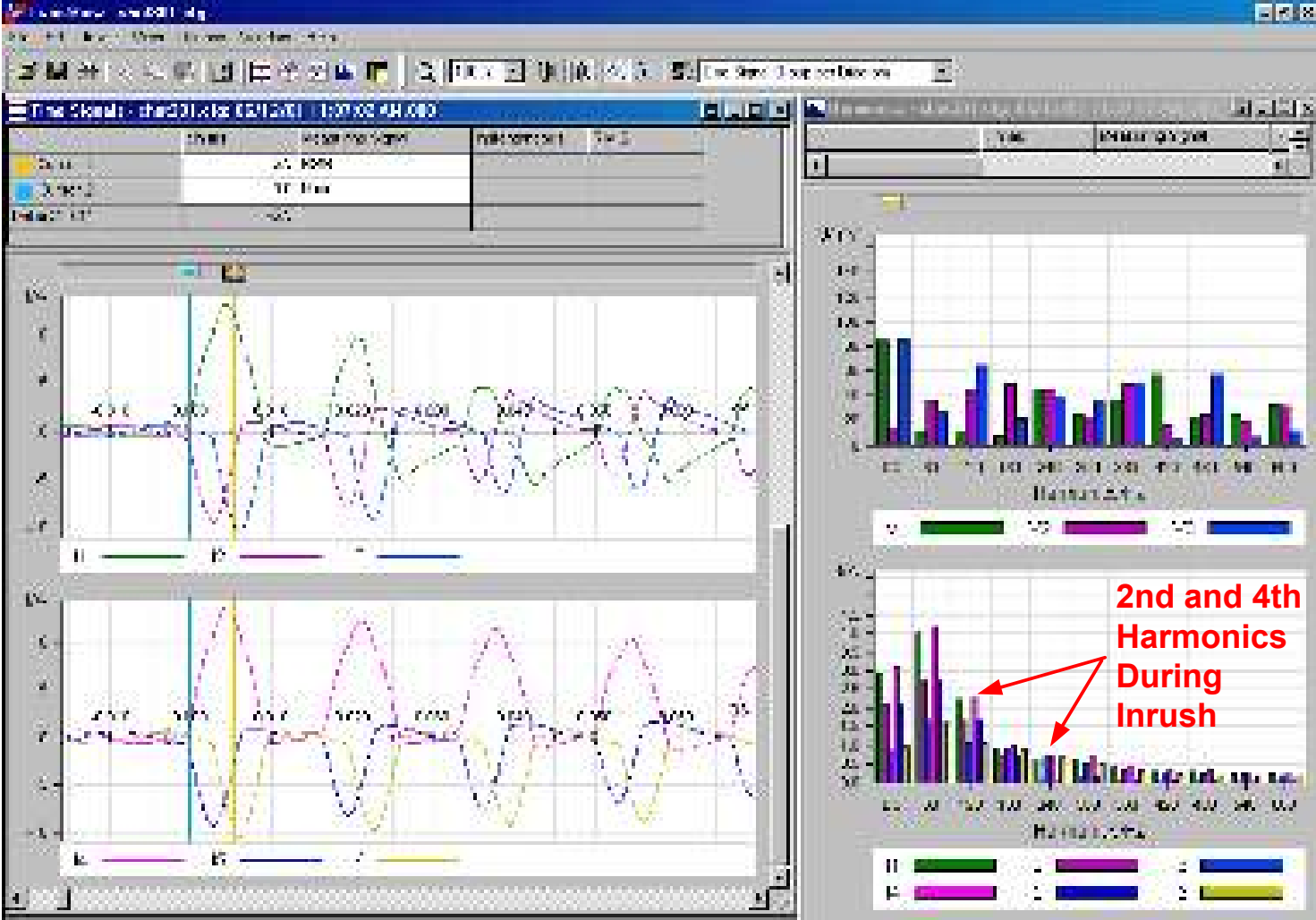
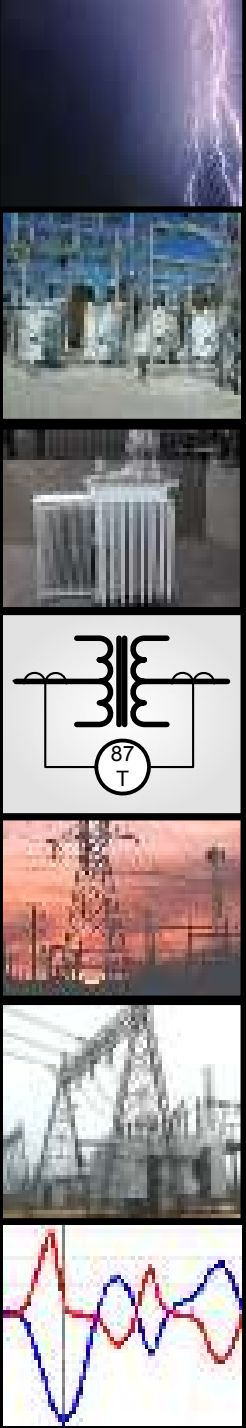

Typical Transformer Inrush Waveform

Cross Phase Averaging

$$I_{dc_{PA24}} = \sqrt{I_{A_{d24}}^2 + I_{B_{d24}}^2 + I_{C_{d24}}^2}$$

- Provides security if any phase has low harmonic content during inrush or overexcitation
- This can occur depending on the voltage point-on-wave when the transformer is energized for a given phase
- Cross phase averaging uses the average of harmonics on all three phases to determine level

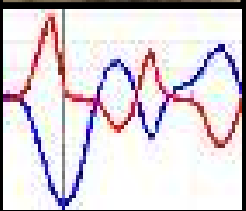
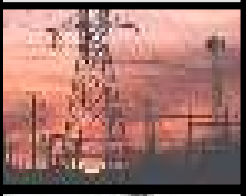
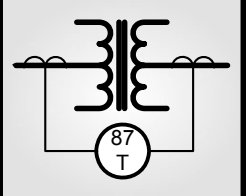

Advanced Element Design: 87T

- **Overexcitation Restraint**

- Overexcitation occurs when volts per hertz level rises (V/Hz)
- This typically occurs from load rejection and malfunctioning generation AVR's
- The voltage rise at nominal frequency causes the V/Hz to rise
- This causes 5th harmonics to be generated in the transformer as it begins to go into saturation
- The current entering the transformer is more than the current leaving due to this increase in magnetizing current
- This causes the differential element to pick-up
- Use 5th harmonic level to detect overexcitation

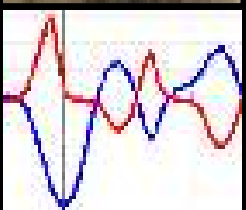
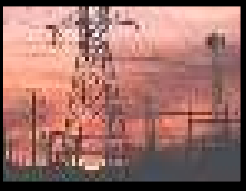
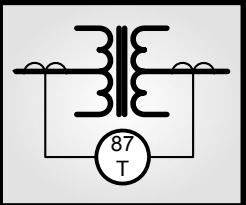

Advanced Element Design: 87T

- Overexcitation Restraint

- Most other relays block the differential element from functioning during transformer overexcitation
- M-3310/M-3311 do not block it, but rather raise the pick up level to accommodate the difference currents caused by the transformer saturation
- This allows the differential element to trip if an internal fault occurs during the overexcitation period due to increased stress level on the insulation
- Result: Improved reliability while not sacrificing security

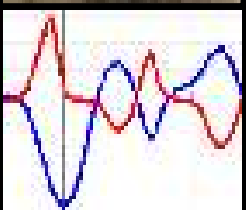
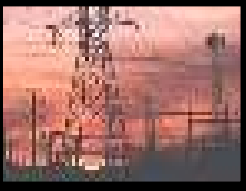
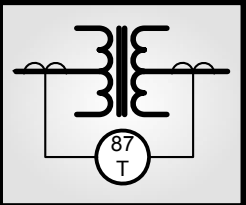

Trip Characteristic – 87T

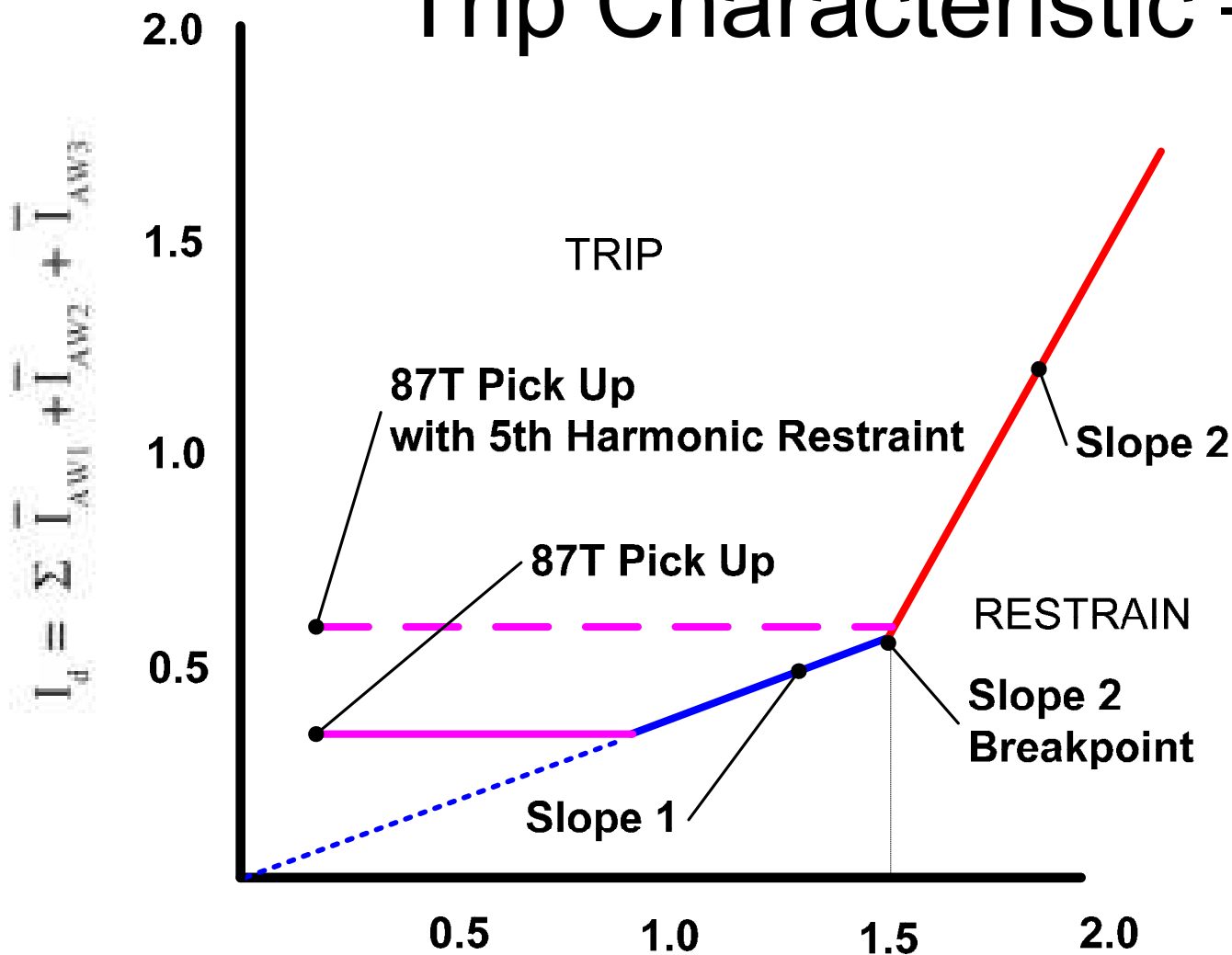

$$I_R = \frac{\sum |I_{AW1}| + |I_{AW2}| + |I_{AW3}|}{2}$$

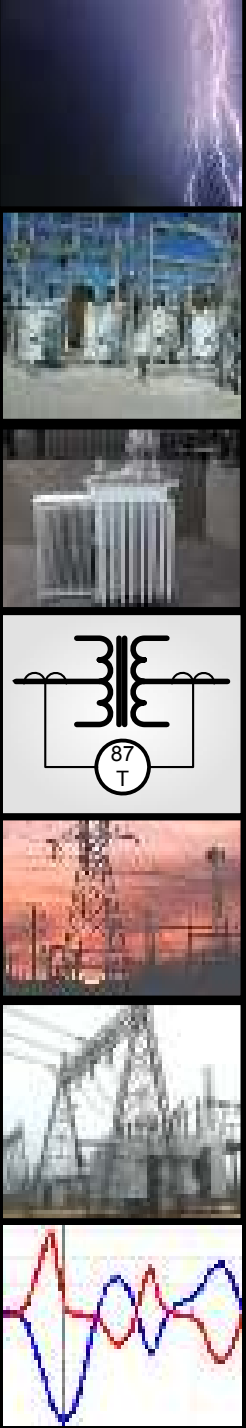

Trip Characteristic – 87T

- 87T Pick Up
 - Class C CTs, use 10%
 - 5% Margin
 - LTC, add 10%
 - Magnetizing losses, add 1%
 - 0.15 to 0.3 pu typically setting
- Slope 1
 - Used for low level currents
 - Can be set as low as 15%
 - With LTC 25-30%
- Slope 2 “breakpoint”
 - Typically set at 2X rated current
 - This setting assumes that any current over 2X rated is a through fault or internal fault, and is used to desensitize the element against unfaithful replication

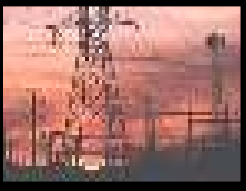
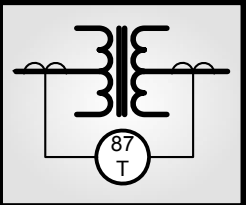

Trip Characteristic – 87T

- Slope 2
 - Typically set at 60% (double slope 1)
- Inrush Restraint (2nd and 4th harmonic)
 - Typically set from 10-15%
 - Employ cross phase averaging blocking for security– Blocks tripping for 10 cycles
- Overexcitation Restraint (5th harmonic)
 - Typically set at 30%
 - Raise 87T pick up by 200% or 0.60 pu during overexcitation
 - No cross phase averaging needed, as overexcitation is symmetric on the phases

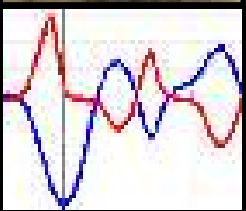
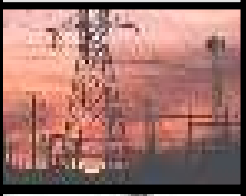
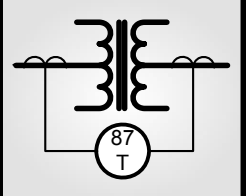

Trip Characteristic – 87H

- 87H Pick Up
 - Typically set at 10pu rated current
 - This value should be above maximum possible inrush current and lower than the CT saturation current
 - C37.91, section 5.2.3, states 10pu an acceptable value
 - Can use data captured from energizations to fine tune the setting

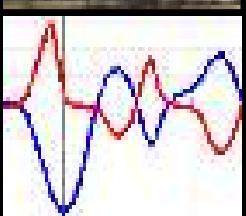
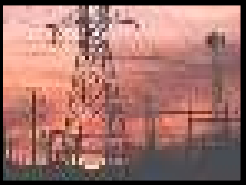
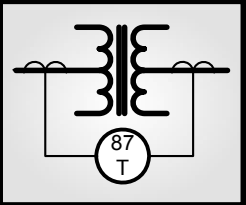

CT Issues

- **Remnance**: Residual magnetism that causes dc saturation of the CTs
- **Saturation**: Error signal resulting from too high a primary current combined with a large burden
- **Tolerance**: Class “C” CTs are rated 10% for currents x20 of nominal
 - Thru-faults and internal faults may reach those levels depending on ratio selected

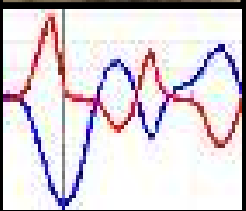
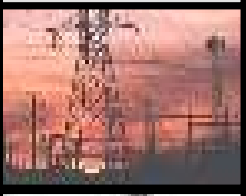
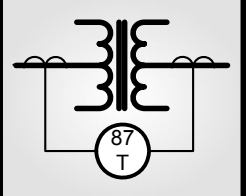

IS THE CT GOOD ENOUGH ?

- Provides security for high fault current levels outside the differential zone where CT inputs can saturate.
- Factors effecting CT saturation
 - Residual magnetism in CT core
 - CT characteristic mismatch
 - CT circuit burden
- CT Burden Check– want to operate below the knee-point voltage (V_k) for worst-case fault external to diff. Zone.

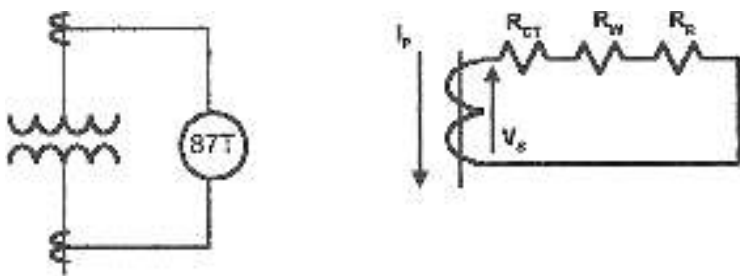

$$V_s = \frac{I_p}{N} [R_{CT} + R_w + R_R]$$

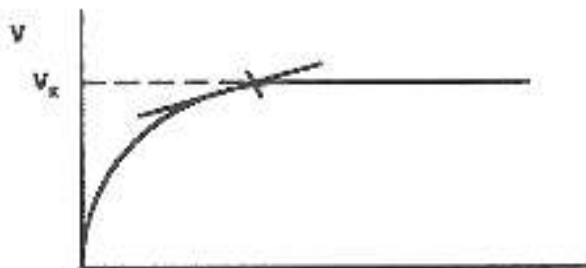

Where I_p is the maximum external fault current

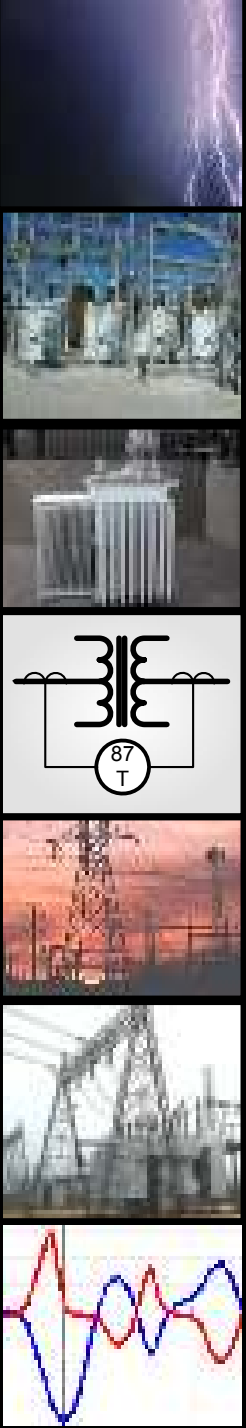

CT Issues

- Best defense is to use high “Class C” voltage levels
 - C200, C400, C800
 - These have superior characteristics against saturation and relay/wiring burden
- Use low burden relays
 - Digital systems are typically 0.020 ohms
- Use a variable percentage slope characteristic to desensitize the differential element when challenged by high currents that may cause replication errors

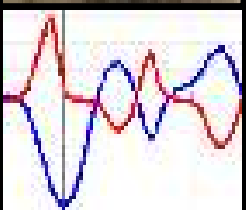
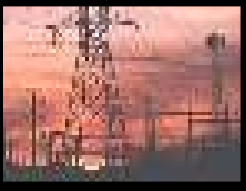
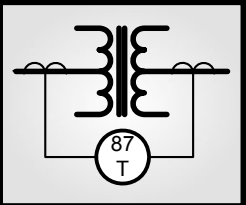

Improved Ground Fault Sensitivity Ground Differential Protection (87GD)

- 87T element is typically set with 15-30% pick up -
- This is to accommodate Class “C” CT accuracy during a fault plus the effects of LTCs
- That leaves 10-15% of the winding not covered for a ground fault (Solidly Grounded Winding)
- **When a neutral resistor limits ground current to 200-400A no ground fault protection is provided for that winding by the 87T element.**
- Employ a ground differential element to improve sensitivity (87GD)

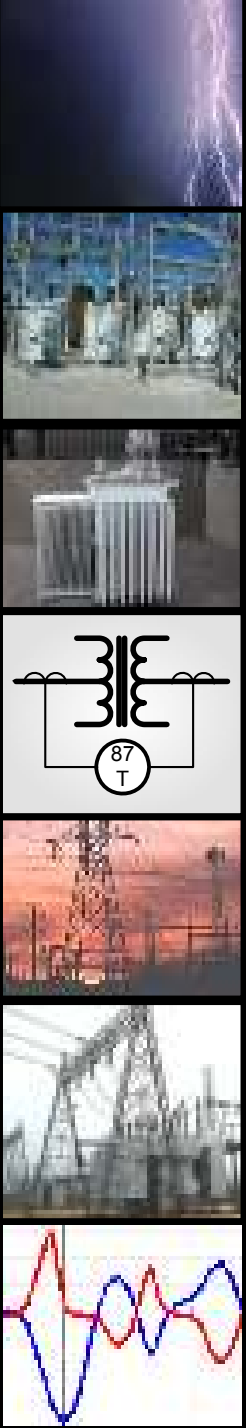

Differential Sensitivity Reduced for Ground Fault Near the Neutral

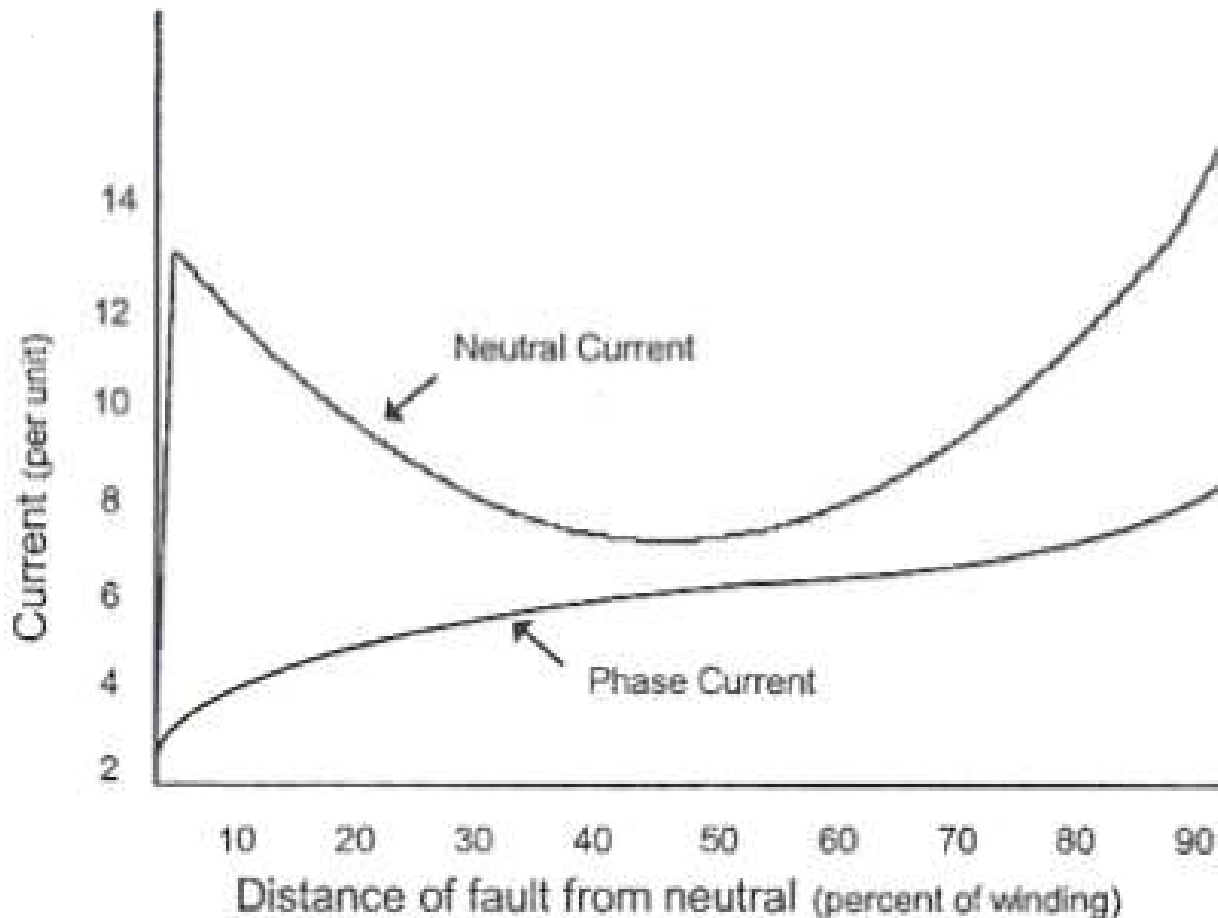
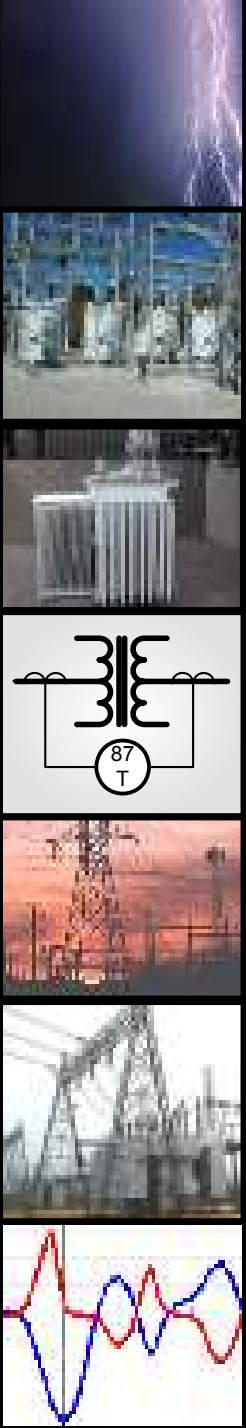

Improved Ground Fault Sensitivity

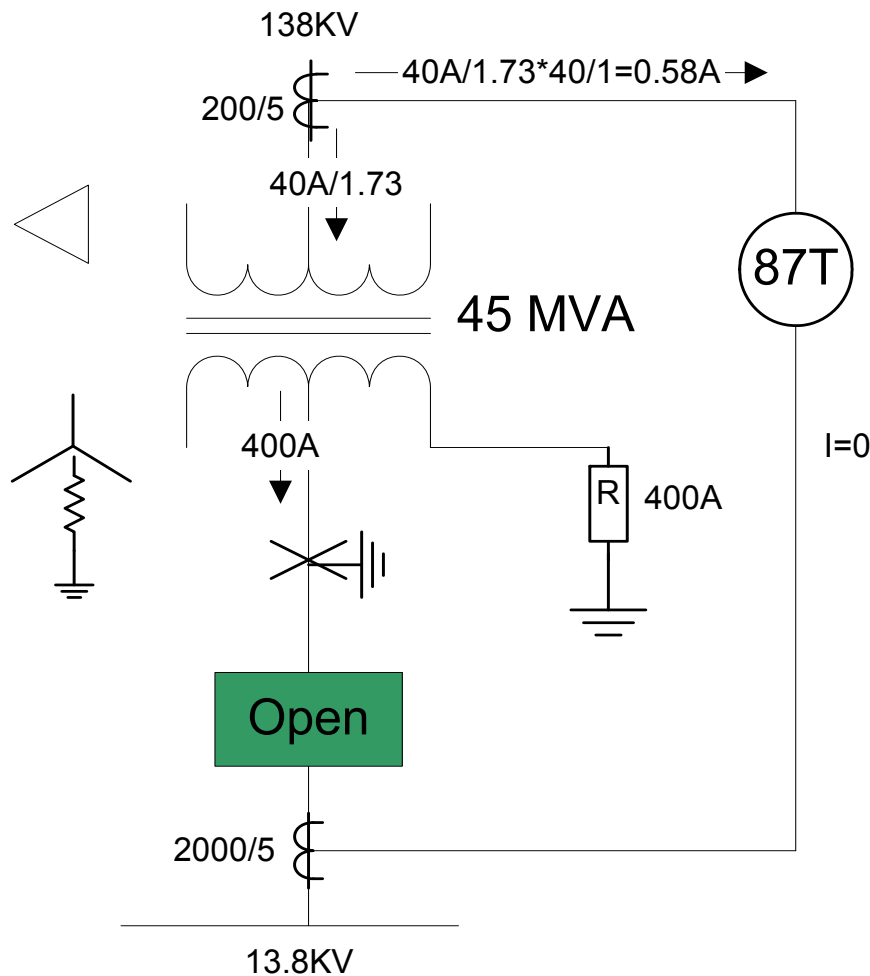

Typical Pickup of 87T:

- 0.3 pu pickup
 - Relay Tap set at Trans. Rating (45MVA)
- $I_{FL138KV} = 4.71$
Amps
- $PU = 4.71A \times 0.3 = 1.41A$

- WITHOUT GROUND DIFF. (87GD) THERE IS NO HIGHSPEED PROTECTION FOR SEC. GND FAULTS

Improved Ground Fault Sensitivity

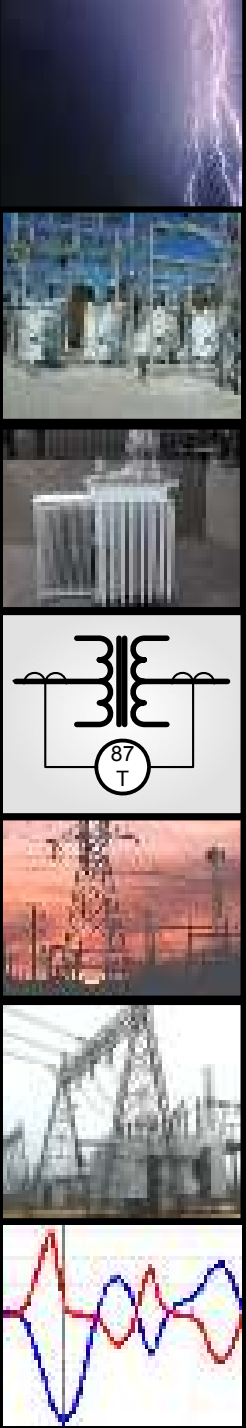

Zone of Protection

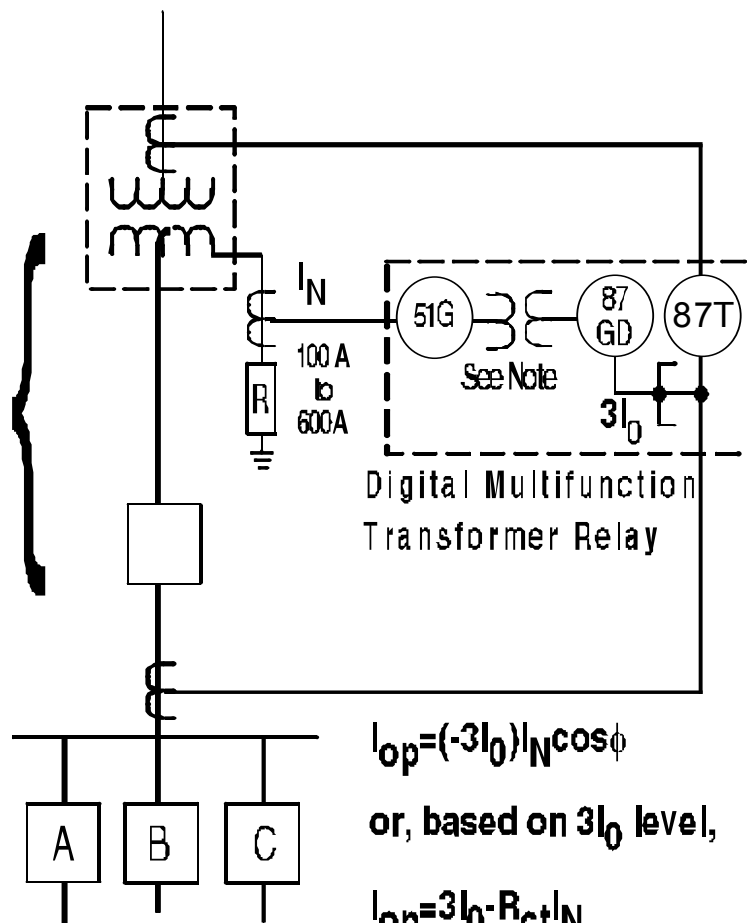

$$I_{op} = (-3I_0) I_N \cos \phi$$

or, based on $3I_0$ level,

$$I_{op} = 3I_0 \cdot R_{ct} I_N$$

■ **NOTE:** R_{ct} is the ratio-matching auxiliary ct implemented through software

Trip Characteristic – 87GD

- 87GD Pick Up

- Element normally uses directional comparison between phase residual current ($3I_0$) and measured ground current (I_G)

- No user setting

- Pick up only applicable when $3I_0$ current is below 140mA (5A nom.)

- Pick up = $3I_0 - I_G$

- If $3I_0$ greater than 140mA, element uses:

- $-3I_0 * I_G * \cos\theta$. It will trip only when the directions of the currents is opposite, indicating an internal fault

- Using direction comparison mitigates the effects of saturation on the phase and ground CTs

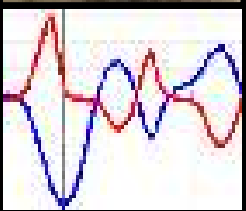
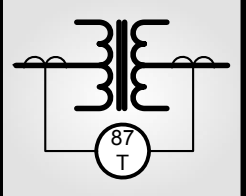

Trip Characteristic – 87GD

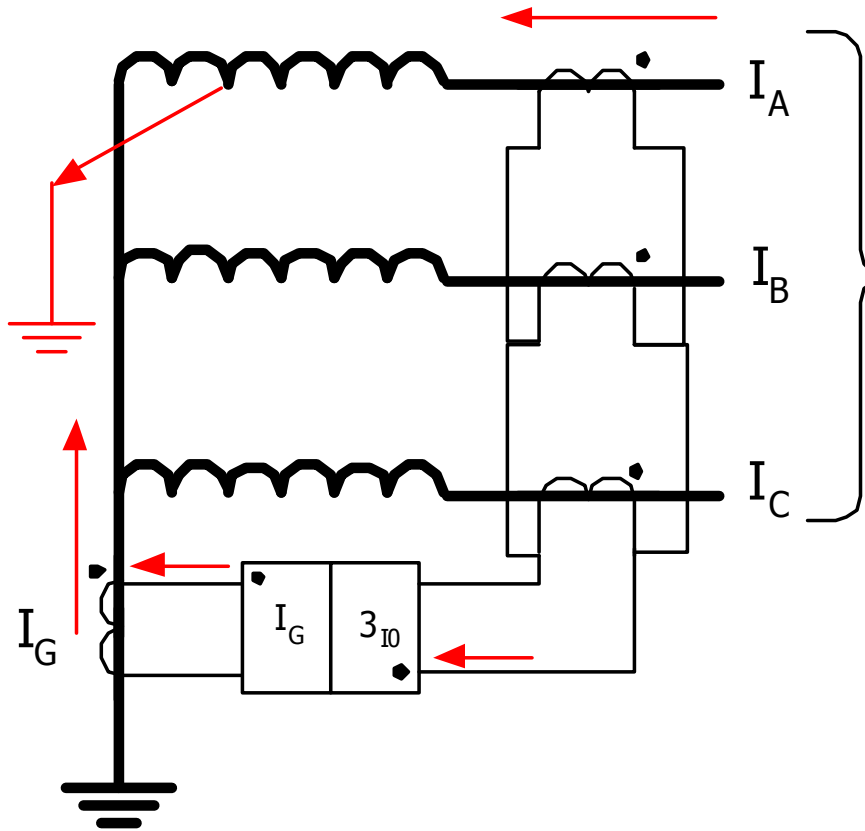

Residual current calculated from individual phase currents. Paralleled CTs shown to illustrate principle.

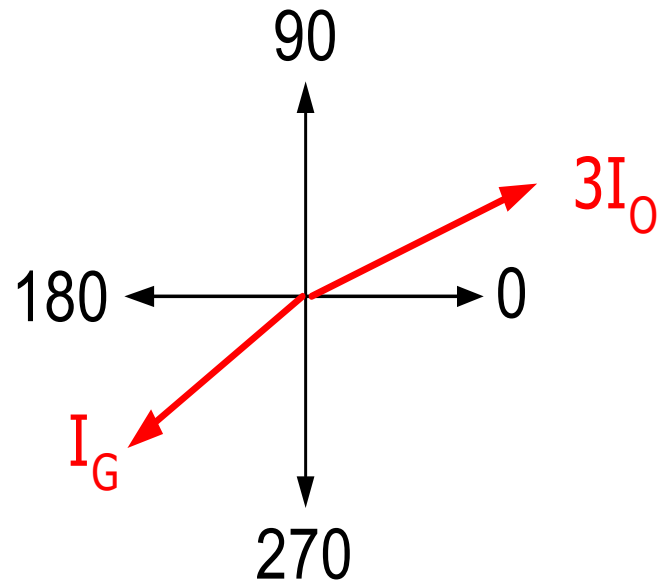

$$-3I_0 \times I_G \cos(180) = 3I_0 I_G$$

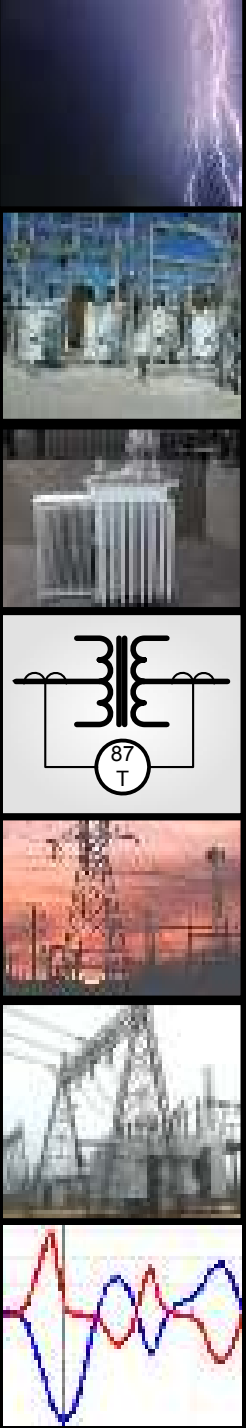

Trip Characteristic – 87GD

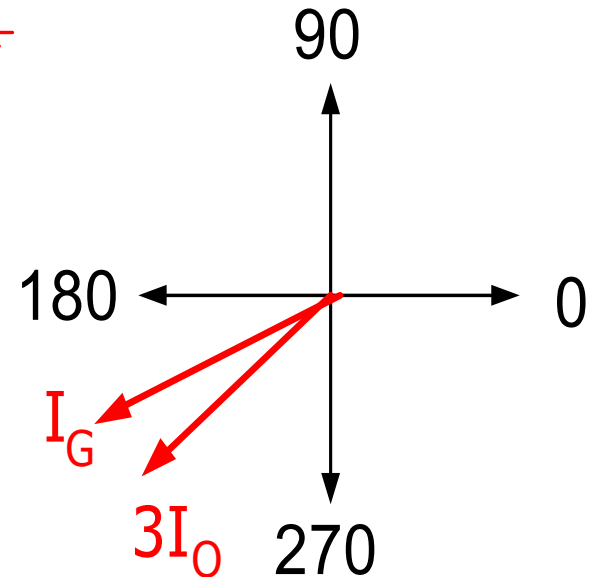
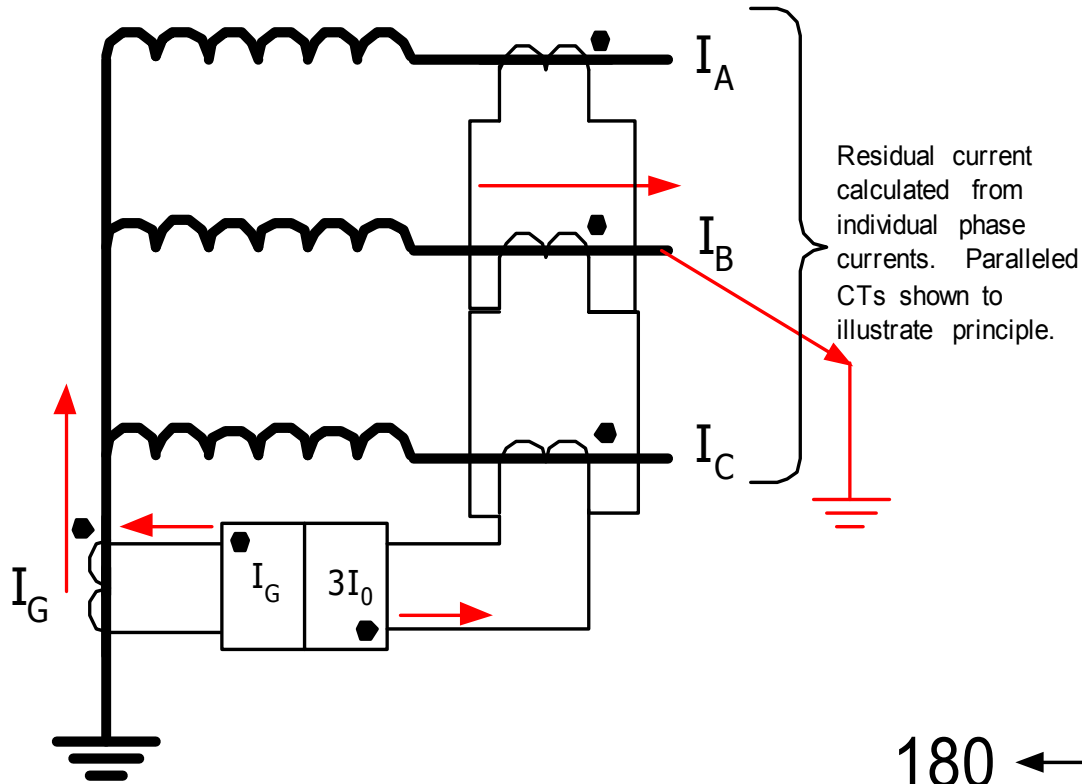

$$-3I_0 \times I_G \cos(0) = -3I_0 I_G$$

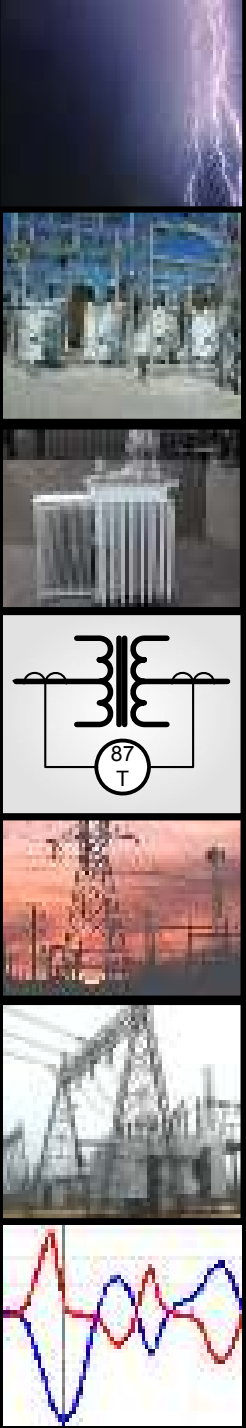

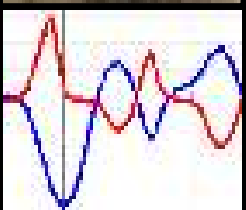
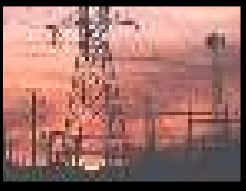
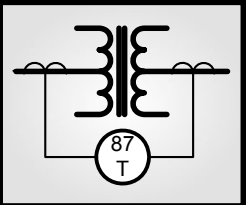

TRANSFORMER OVEREXCITATION PROTECTION

Transformer Limits

- Overexcitation
 - Responds to overfluxing; excessive V/Hz
 - Continuous operational limits
 - ANSI C37.91 & C57.12
 - 1.05 loaded, 1.10 unloaded
 - Measured at the transformer output
 - Inverse curves typically available for values over the continuous allowable maximum
 - Protection required application of V/Hz (24) protection

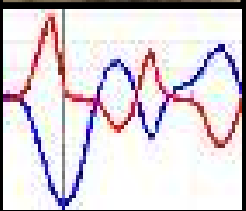
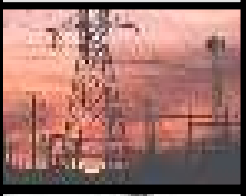
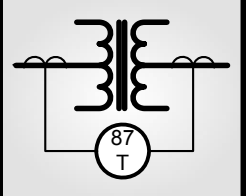

Overexcitation/ Volts per Hertz (24)

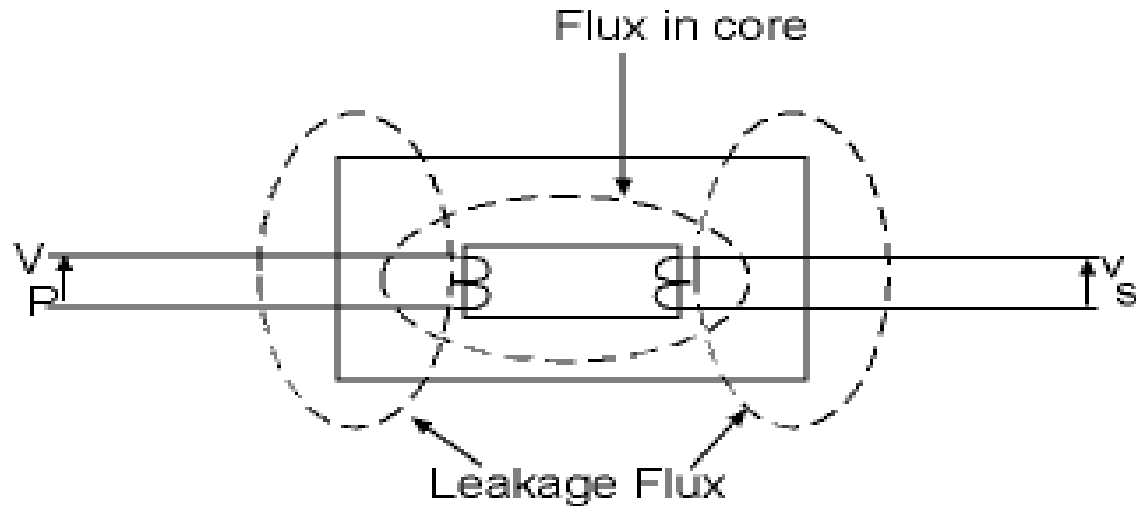

PHYSICAL INSIGHTS

- As voltage rises above rating leakage flux increases
- Leakage flux induces current in transformer support structure causing rapid localized heating

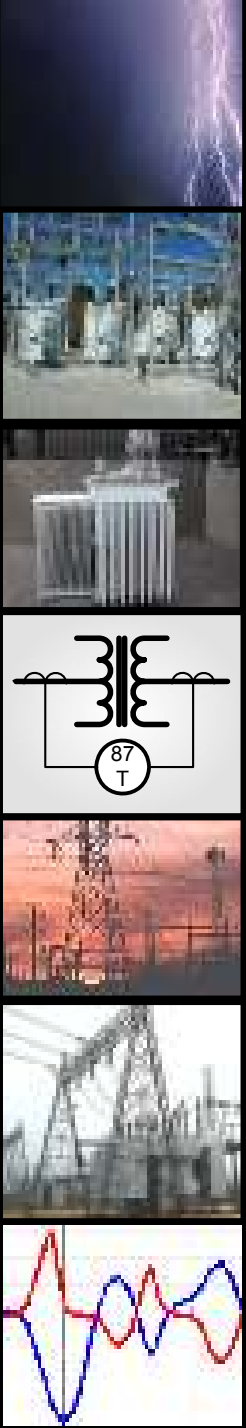

Industrial System Overexcitation

**Power System
High Voltage During Major
System Disturbance**

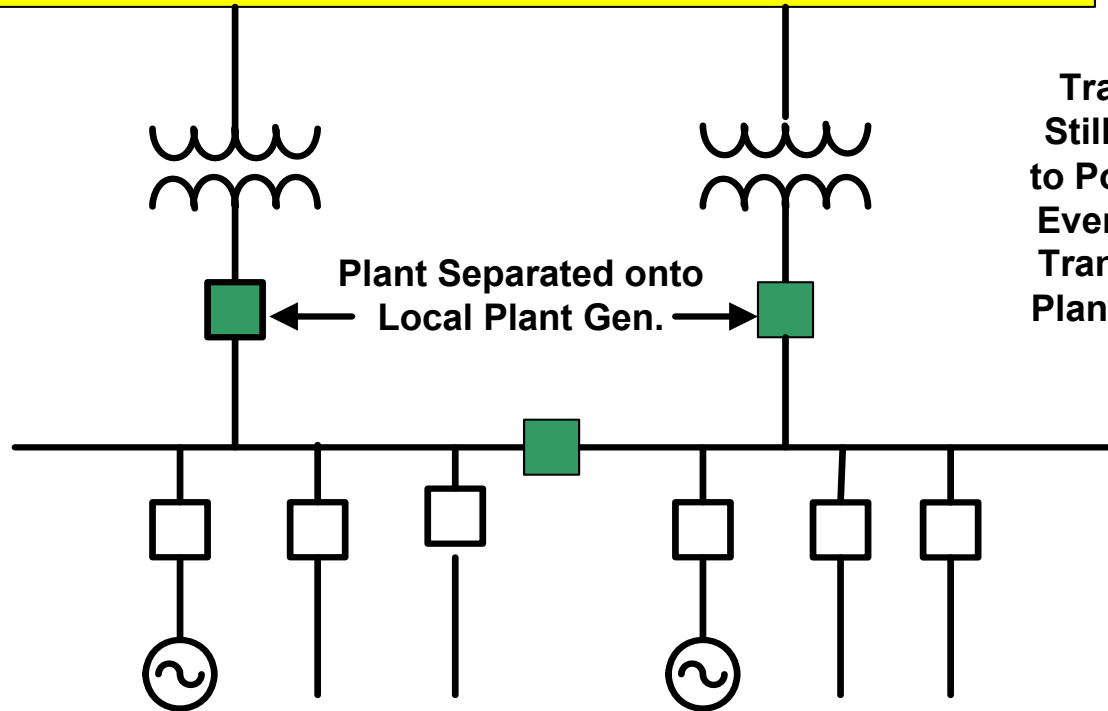

**Transformers
Still Connected
to Power System
Even After Load
Transferred onto
Plant Generation**

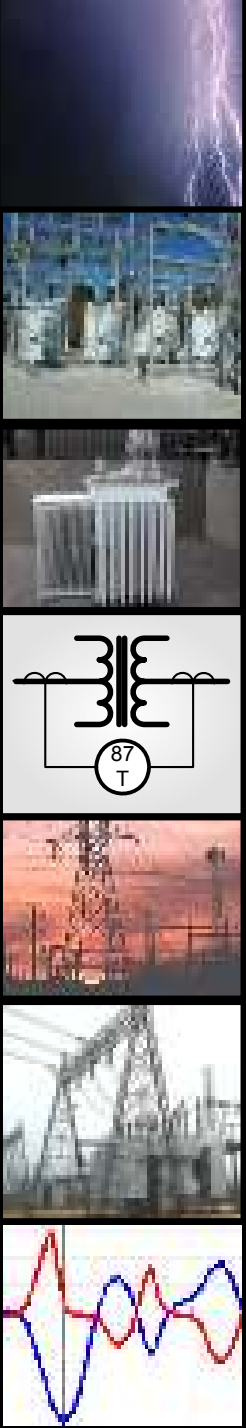

Overexcitation Event on EHV Transmission System

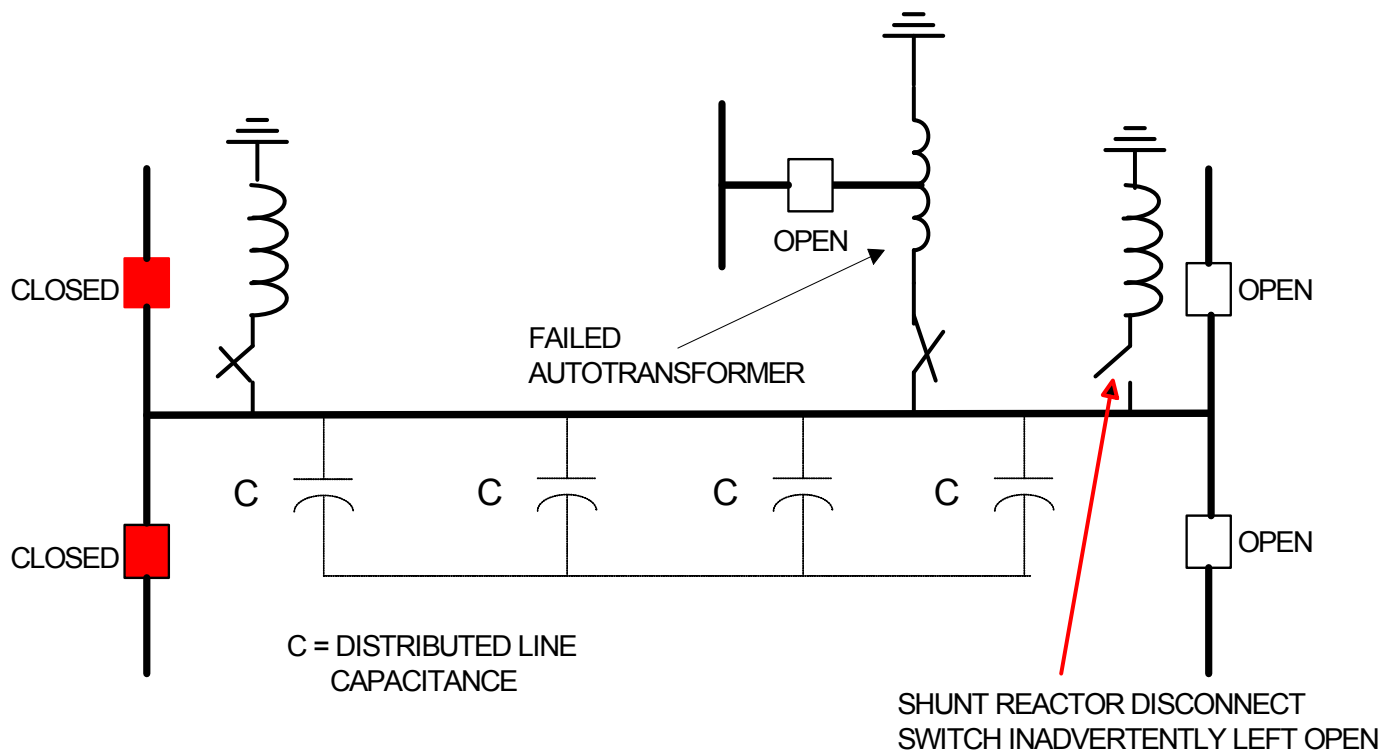
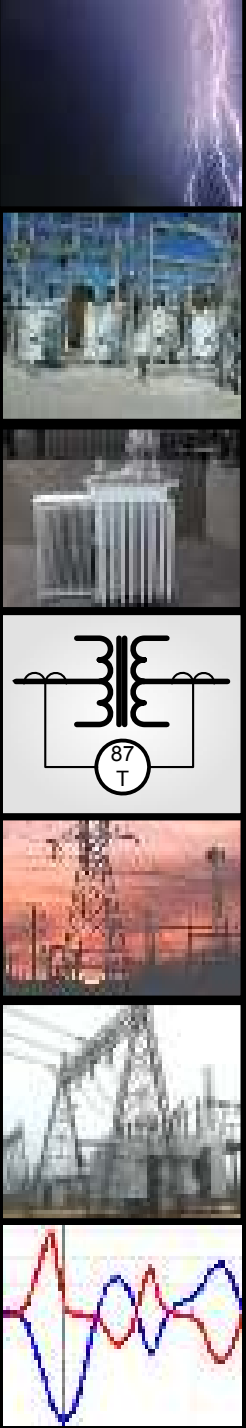
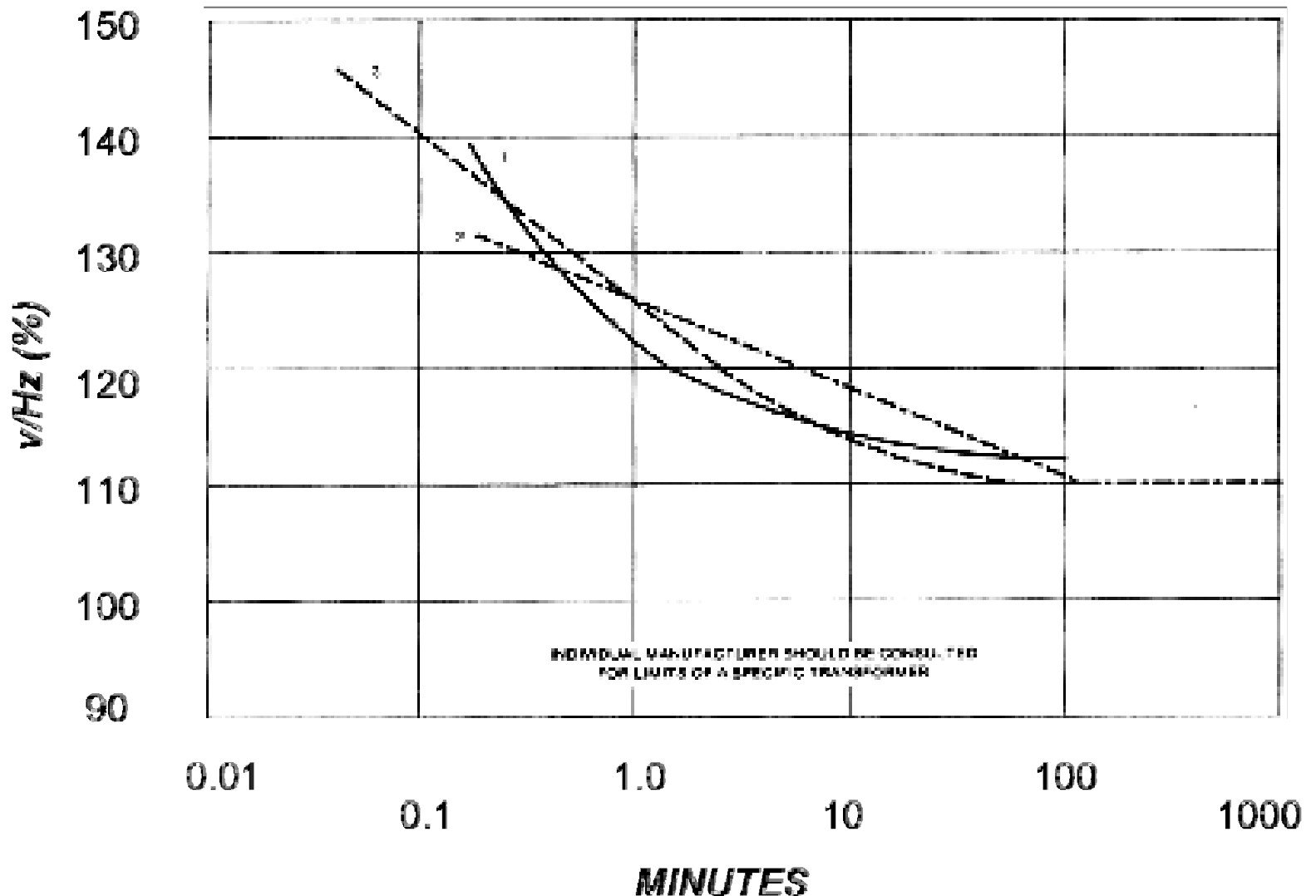

Fig. 11 Overexcitation Failure of an EHV Autotransformer



Overexcitation Curve



This is typically how the apparatus manufacturer specs it

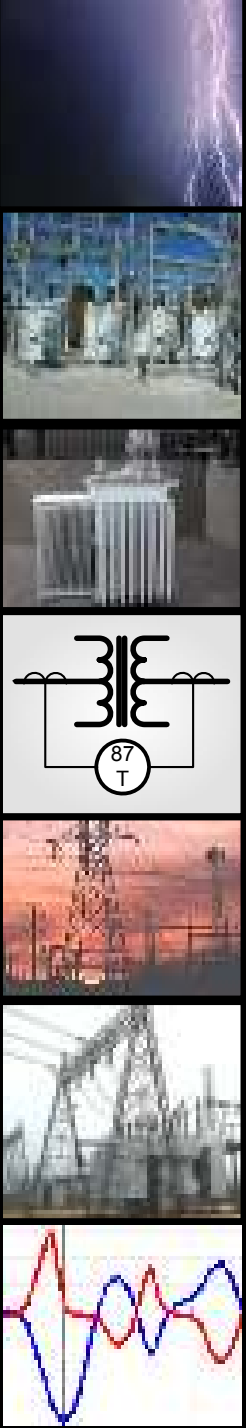

Overexcitation Digital Relay Curve

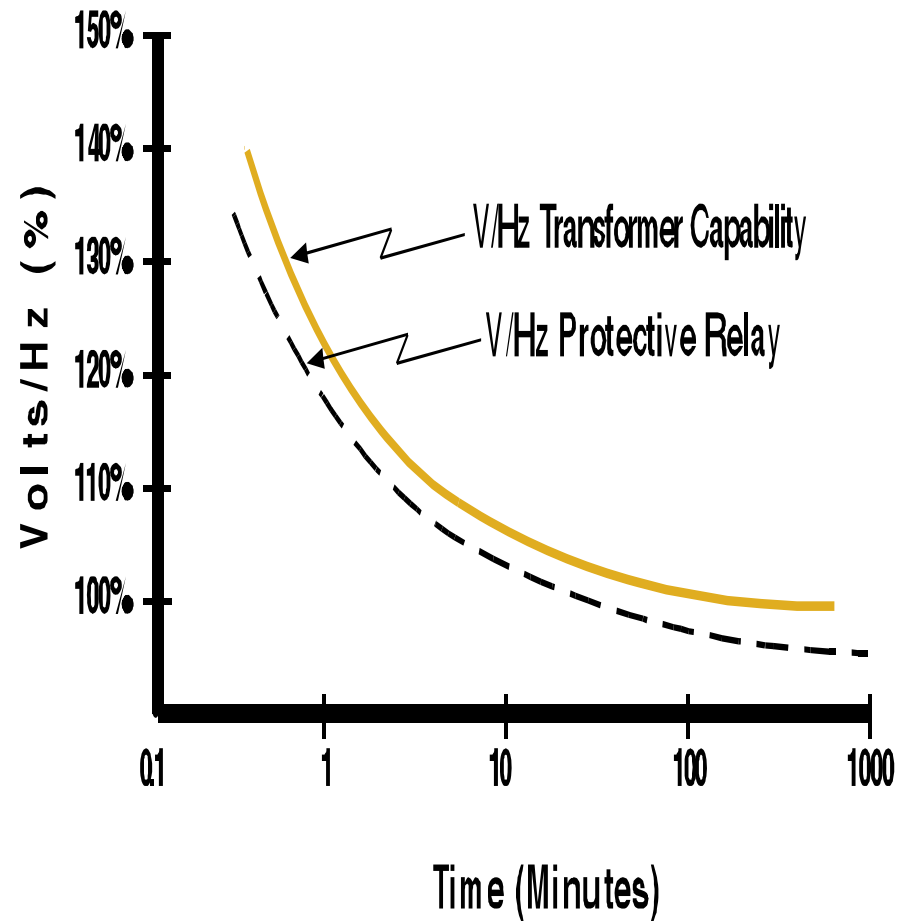
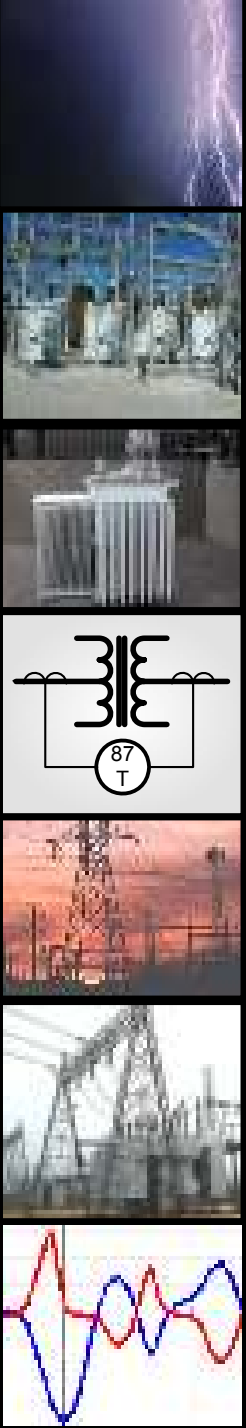

V/Hz Event

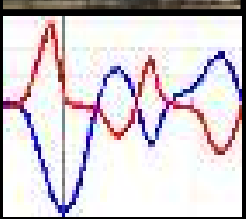
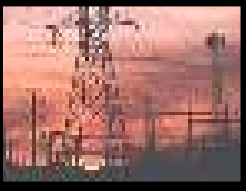
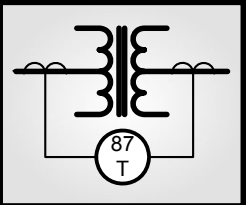
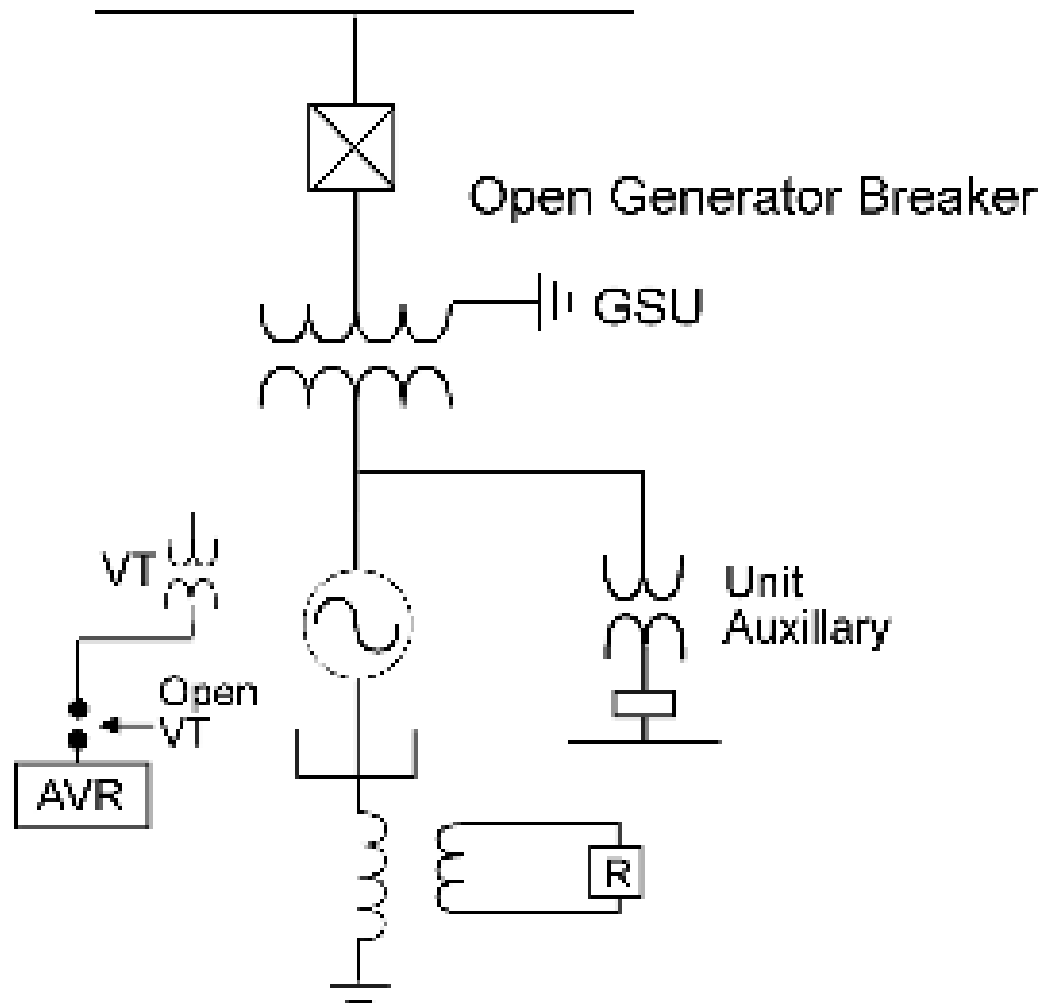

V_A & I_A

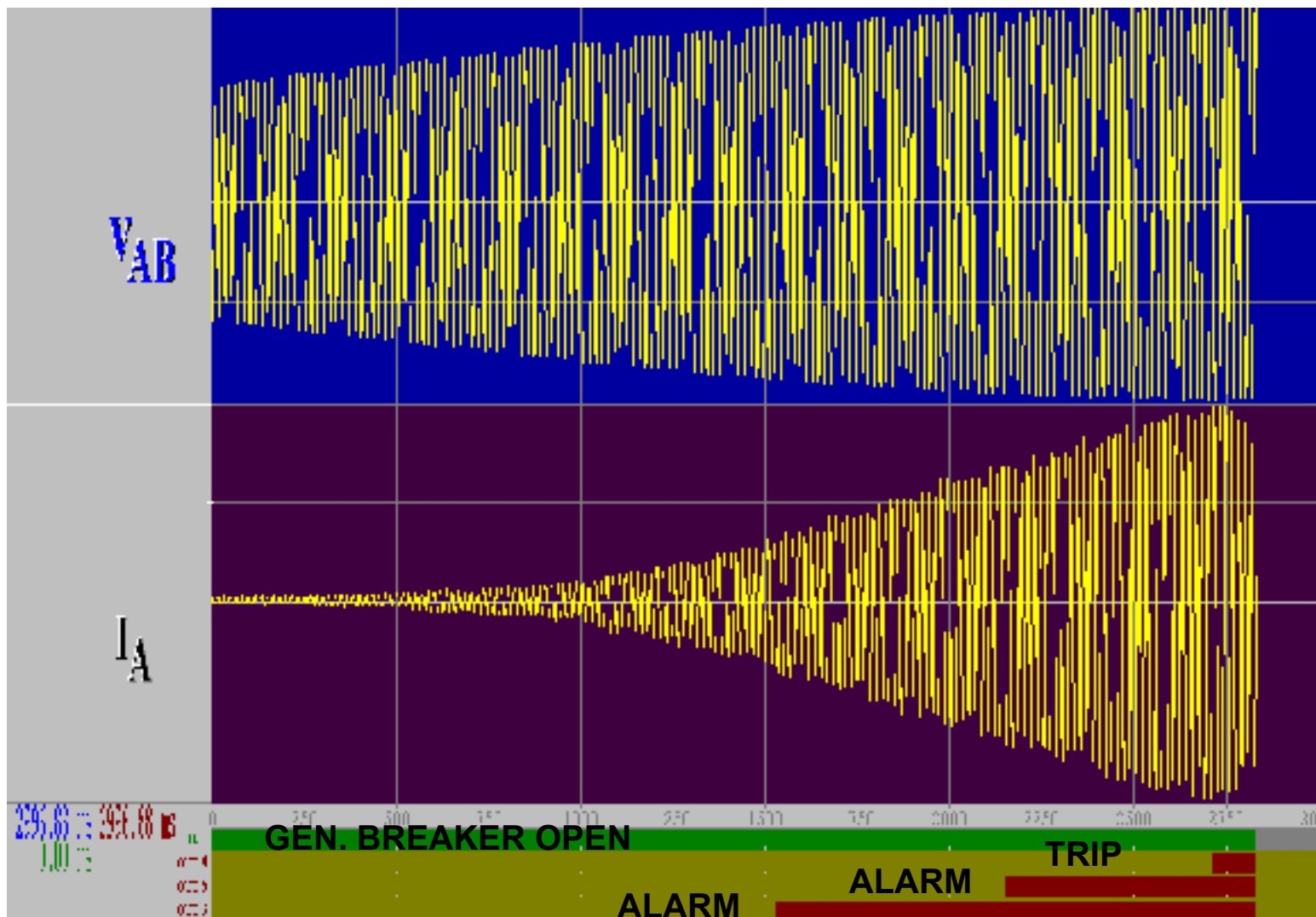
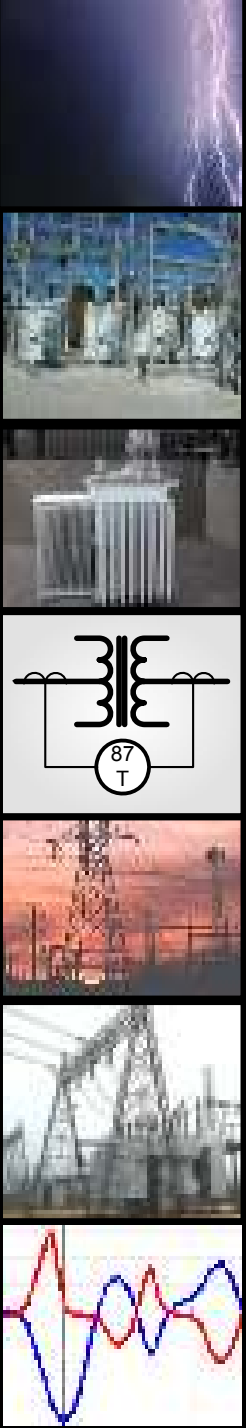

I_A

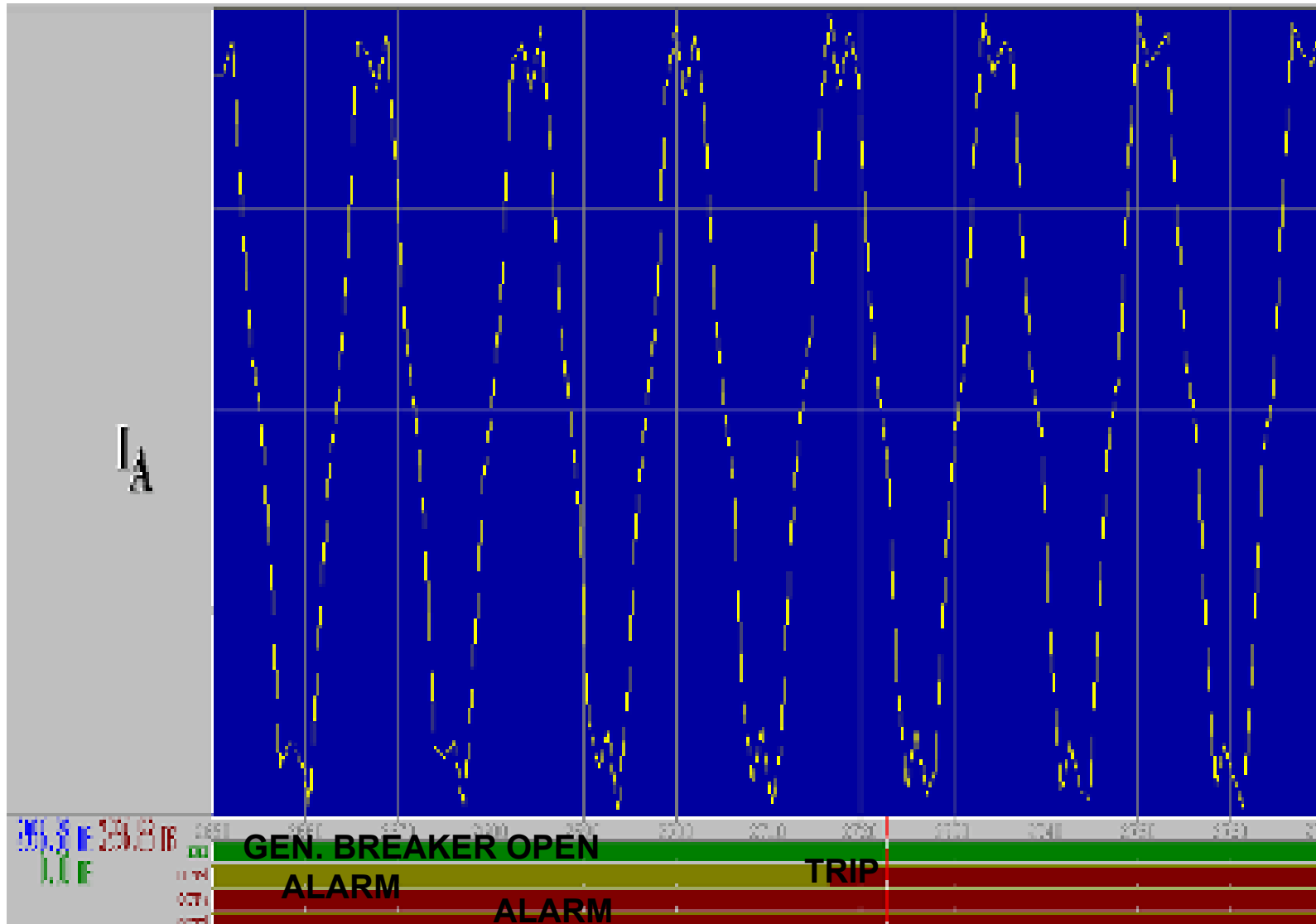
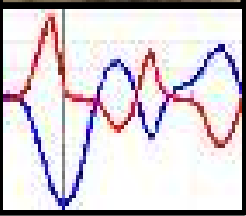
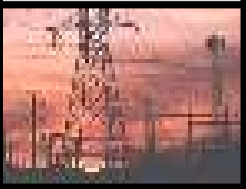
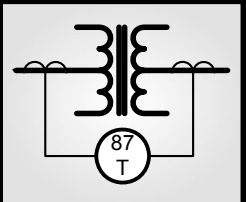

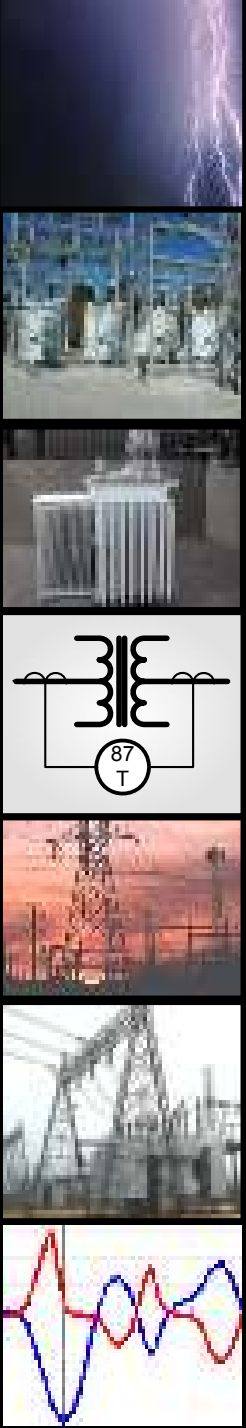

DIGITAL RELAY TRANSFORMER PROTECTION

Digital Transformer Relays

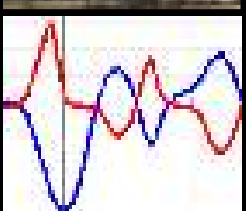
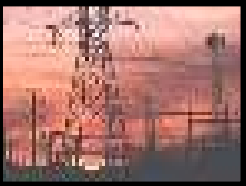
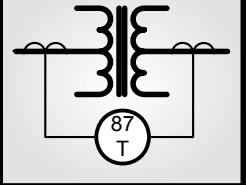
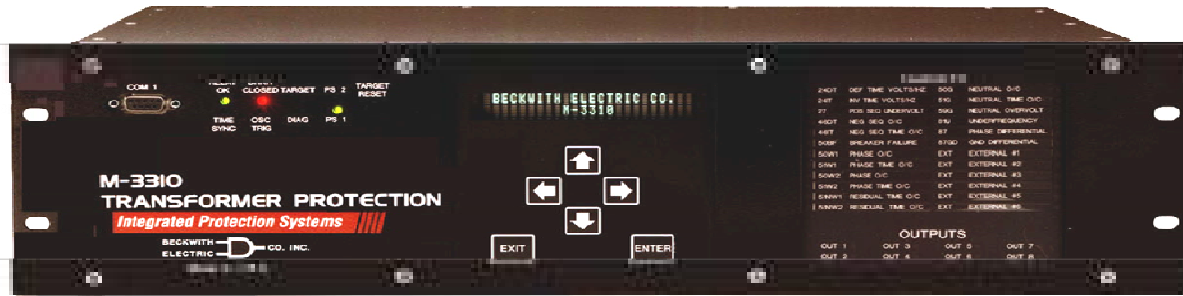

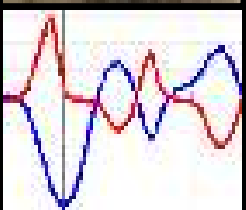
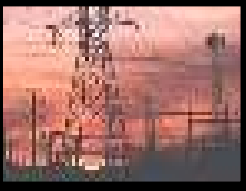
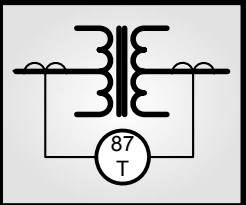

Digital Relay Features

- + Self-Monitoring and Diagnostics.
- + Some Monitoring of VT and CT Inputs.
- + Multiple Input and Output Contacts
- + Multiple Setting Groups
- + Programmable Logic
- + Metering of all Inputs
- + Oscillography and Event Recording
- + Communications

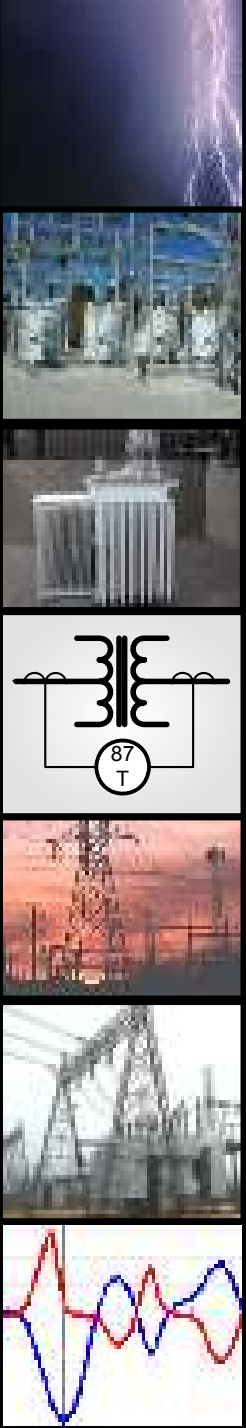



-  This function is available as a standard protective function.
-  This function is available as an optional protective function.

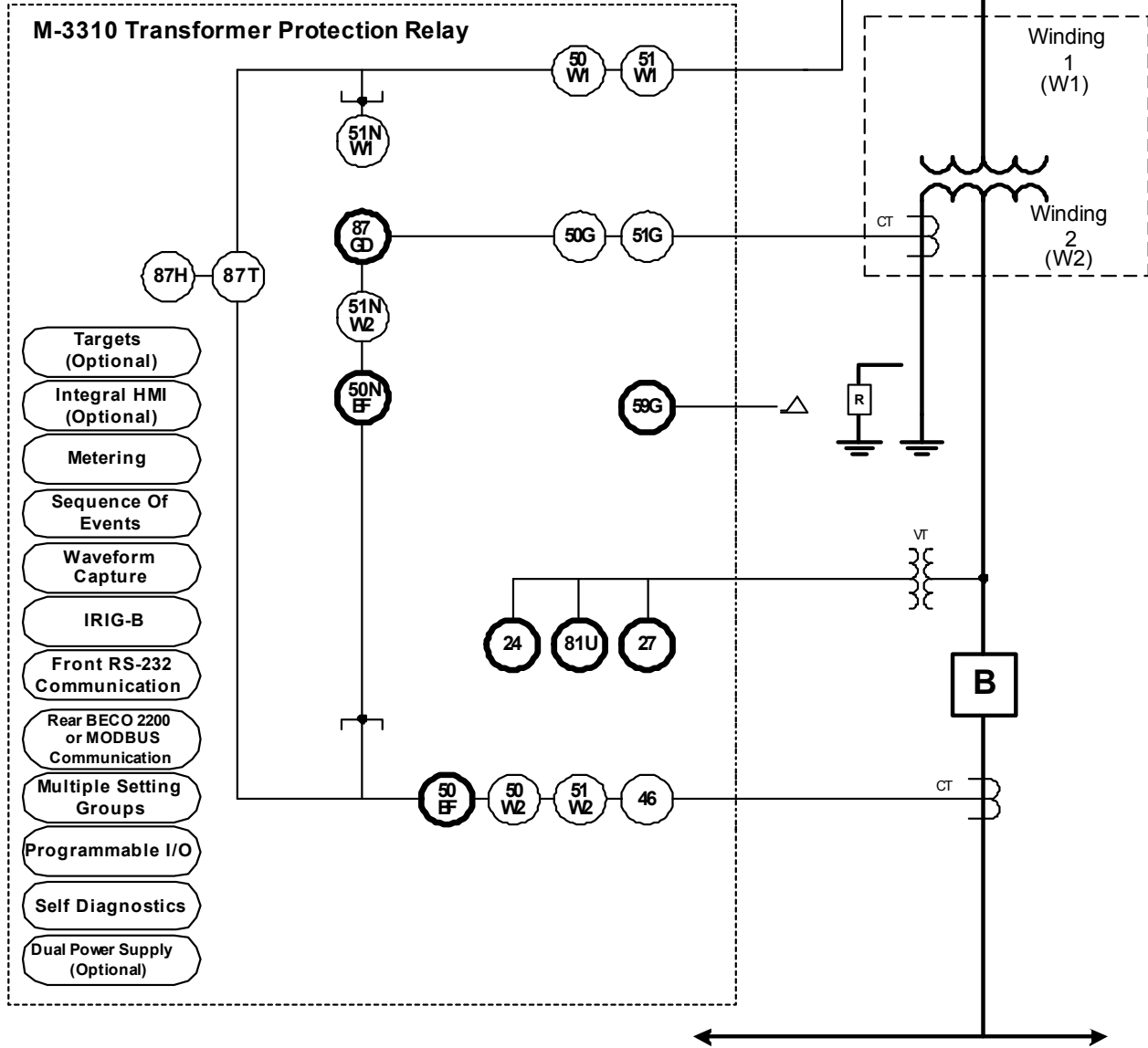

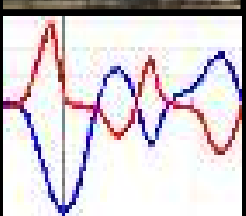
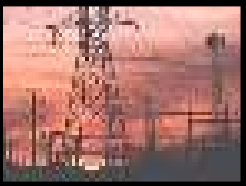
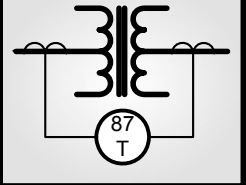

○ This function is available as a standard protective function.

● This function is available as an optional protective function.

- Targets (Optional)
- Integral HMI (Optional)
- Metering
- Sequence Of Events
- Waveform Capture
- IRIG-B
- Front RS-232 Communication
- Rear MODBUS or DNP Communication
- Multiple Setting Groups
- Programmable I/O
- Self Diagnostics
- Dual Power Supply (Optional)
- Breaker Monitoring

M-3311

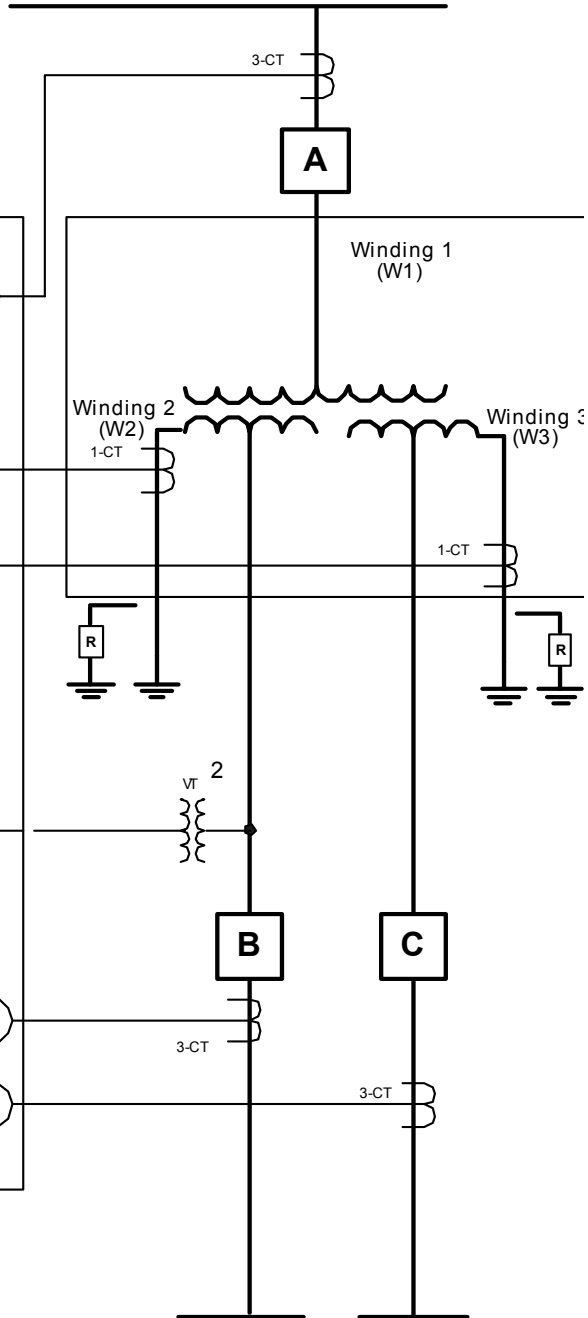
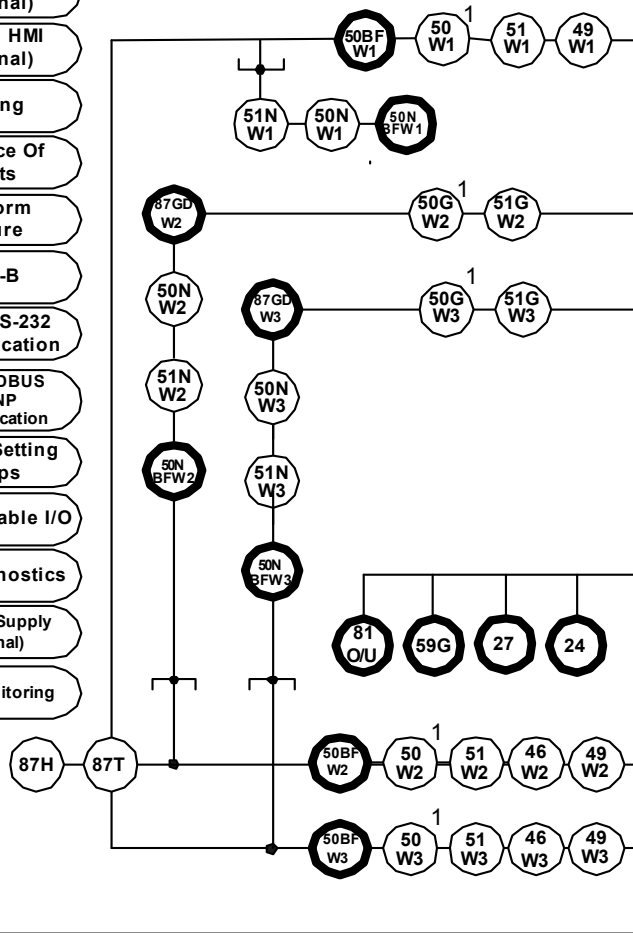

Hardware Block Diagram

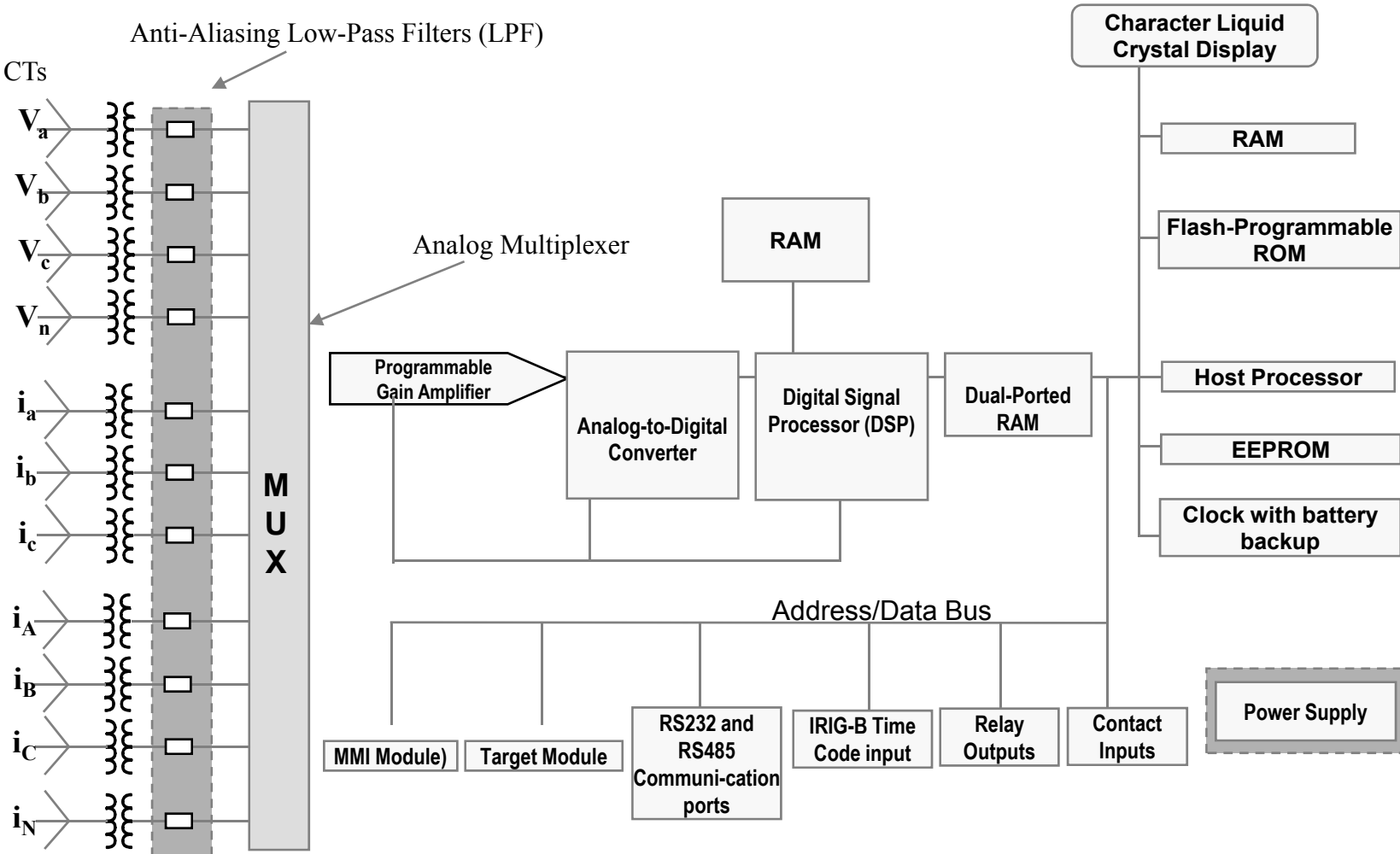
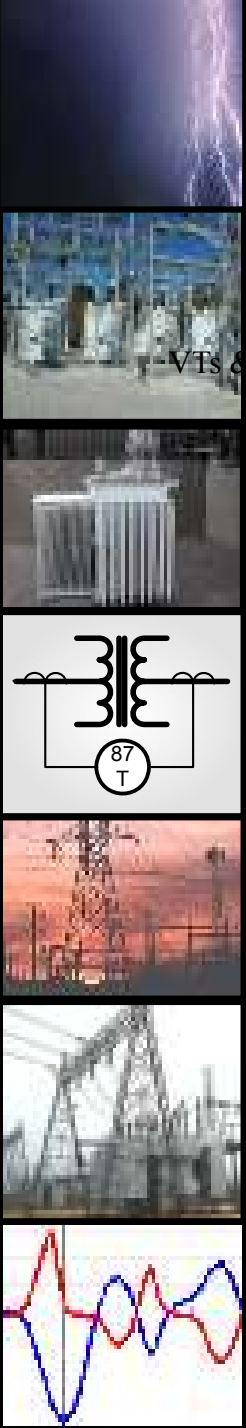

Traditional Approach

Tripping Redundancy

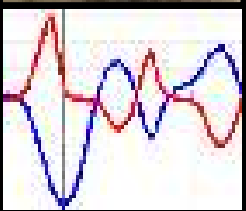
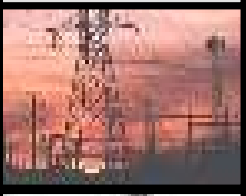
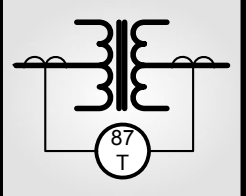
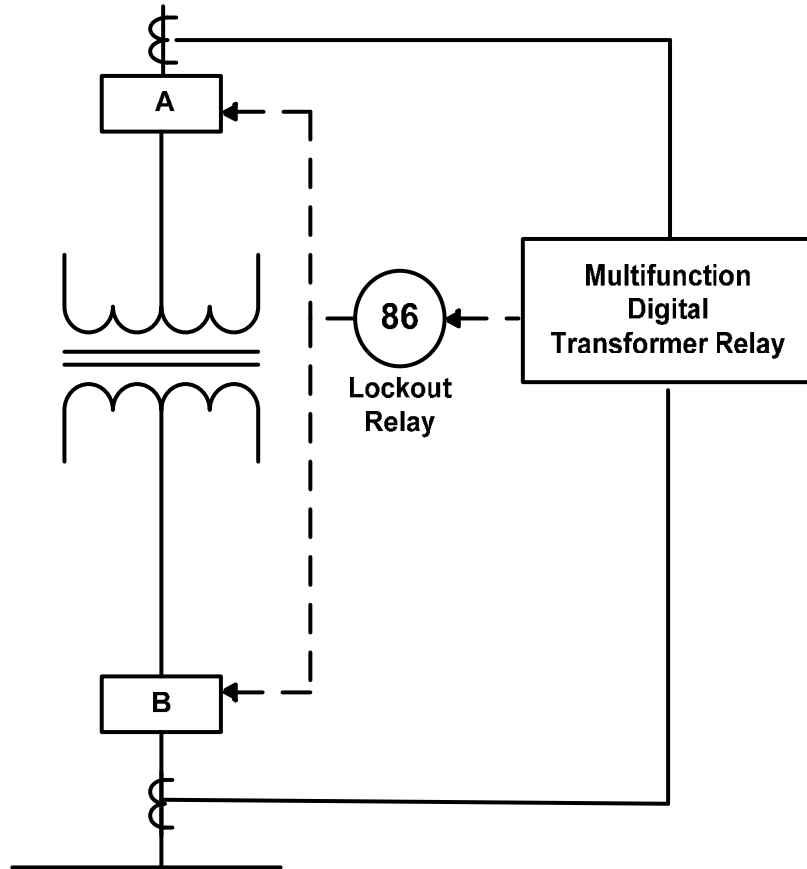

New Approach

Tripping Redundancy Improvement

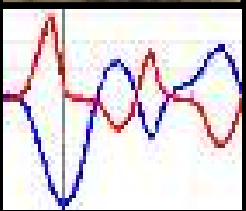
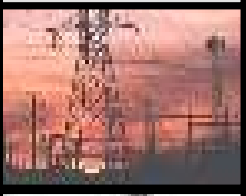
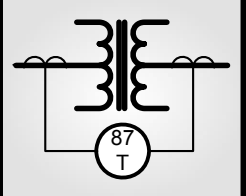
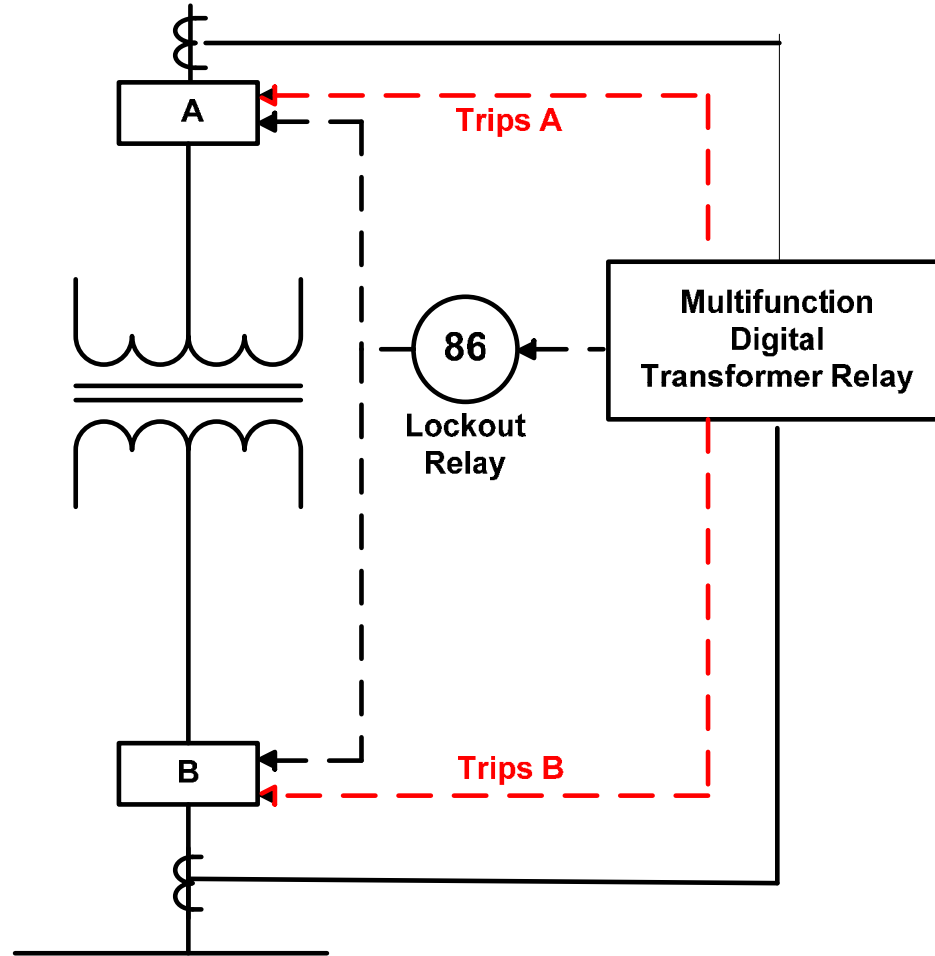

Schemes - Bus Fault Protection

- Use interlocked overcurrent to avoid long time delays
- Inexpensive solution for lower voltage distribution buses

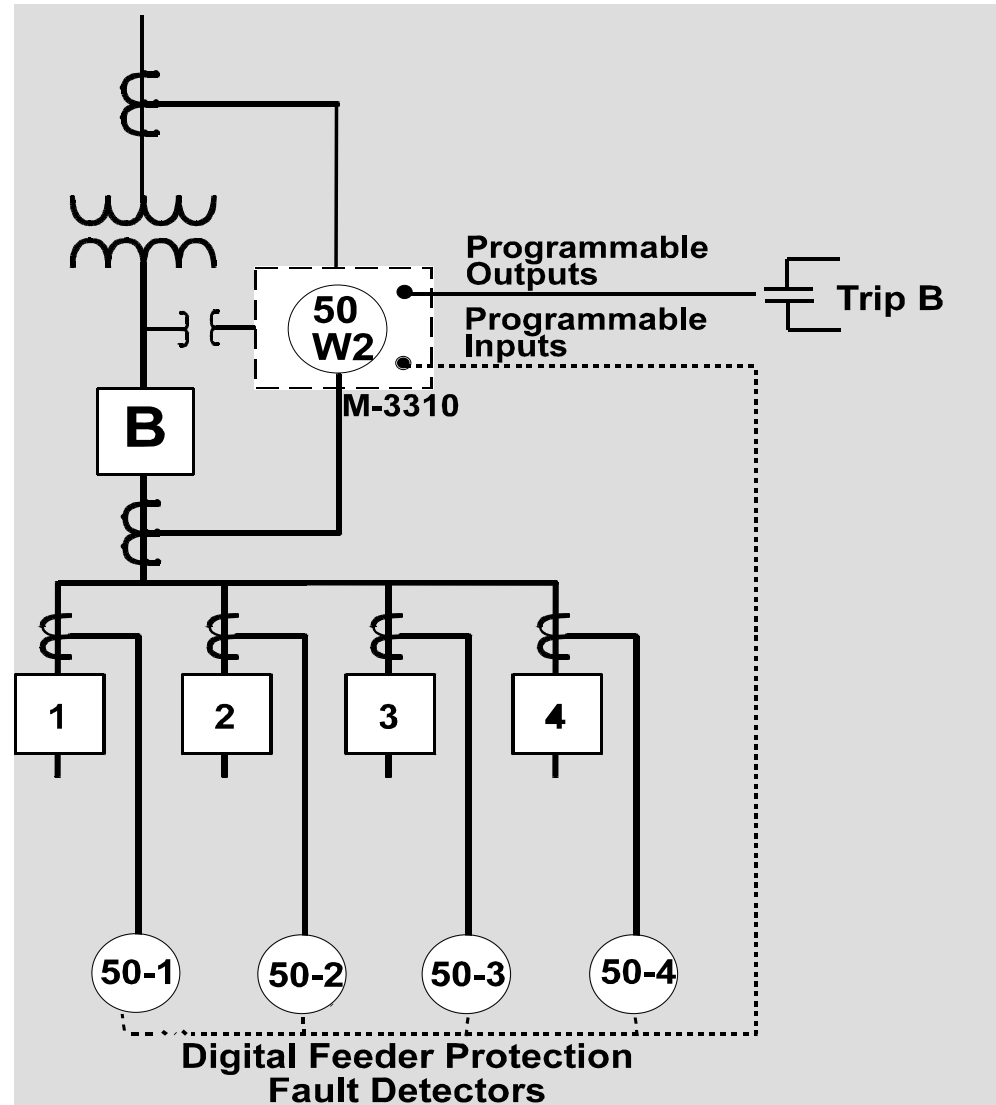

Vector Display, 87

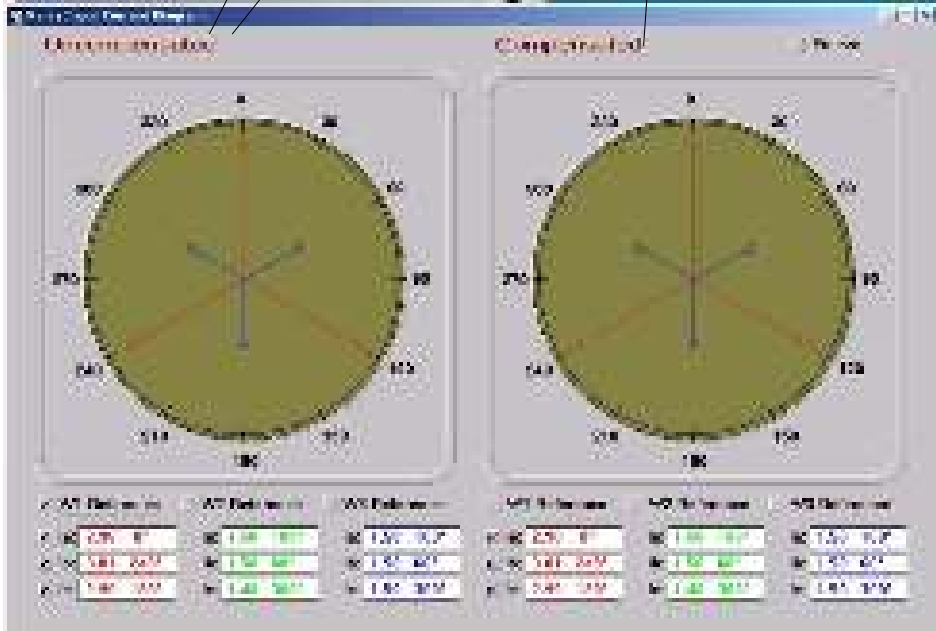
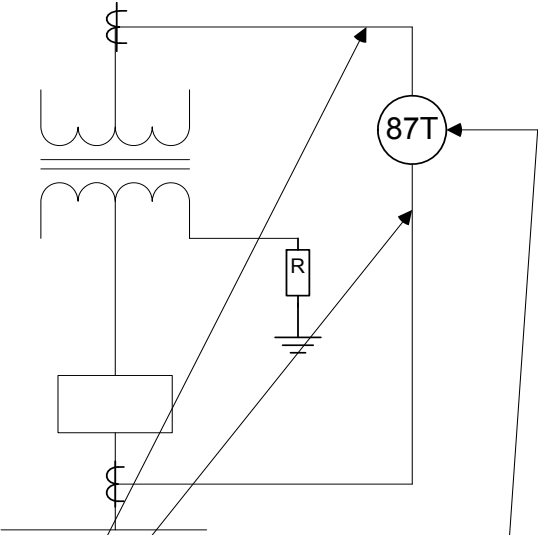
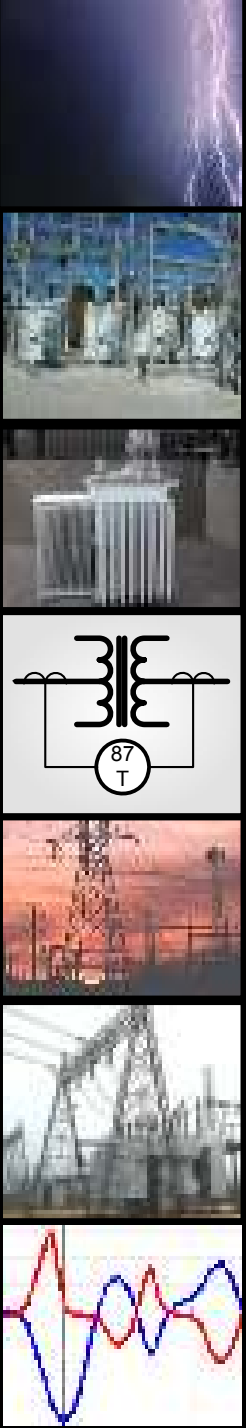

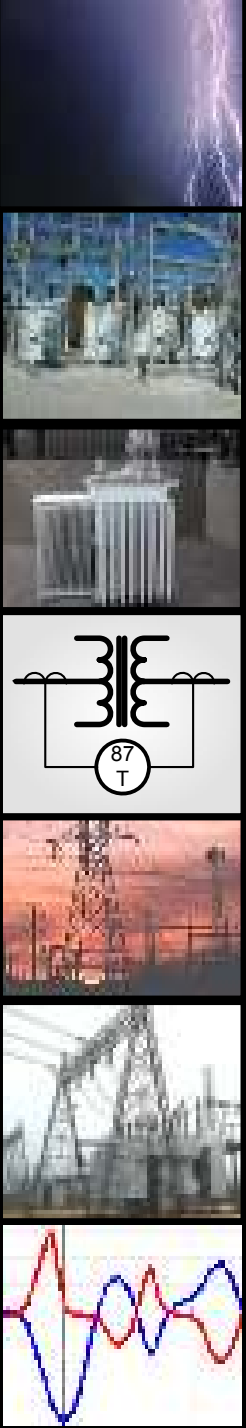

THE END

??

FINAL QUESTIONS

??