

SIEMENS



Air Circuit Breakers

Totally Integrated Power – SENTRON

Configu-
ration
Manual

Edition
10/2014

siemens.com/lowvoltage

3WL Air Circuit Breakers



2

Introduction

3WL air circuit breakers/ non-automatic air circuit breakers up to 6300 A (AC), IEC

General data

- 8 - Design
 - 14 - Function
 - 21 - Configuration
 - 27 - Technical specifications
- Project planning aids
- 37 - Characteristic curves
 - 39 - Dimensional drawings
 - 50 - Circuit diagrams
 - 52 - More information

3WL non-automatic air circuit breakers up to 4000 A (DC)

General data

- 53 - Technical specifications
- Project planning aids
- 54 - Characteristic curves
 - 54 - Dimensional drawings
 - 58 - Circuit diagrams
 - 59 - More information

© Siemens AG 2014
All dimensions in mm.

For further technical product information:

Service & Support Portal:

www.siemens.com/lowvoltage/product-support

→ Product List:
Technical specifications

→ Entry List:
Certificates / Characteristics /
Download / FAQ / Manuals /
Updates

3WL Air Circuit Breakers

Introduction

Overview



Size I



Size II

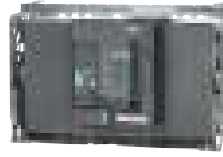

Size III

3WL Air Circuit Breakers

		3WL air circuit breakers/non-automatic air circuit breakers up to 6300 A (AC), IEC				3WL non-automatic air circuit breakers up to 4000 A (DC)	
Size		I, II, III				II	
Rated current I_n	A	630, 800, 1000, 1250, 1600, 2000, 2500, 3200, 4000, 5000, 6300				1000, 2000, 4000	
Number of poles		3-pole, 4-pole				3-pole, 4-pole	
Rated operational voltage U_e	V AC V DC	... 690/1000/1150 --				... 1000	
Rated ultimate short-circuit breaking capacity at 500 V AC	kA	Size I 55/66/85	Size II 66/80/100	Size II 130	Size III 100/150 (3-pole), 130 (4-pole)	30/25/20 (at 300/600/1000 V DC)	
Endurance	Operating cycles	Up to 20000	15000	10000	10000	15000	
Mounting position							
Degree of protection	With cover Without cover (with door sealing frame)	IP55 IP41				IP55 IP41	
Dimensions 3-/4-pole	W mm H mm D mm	320/410	460/590	460/590	704/914	460/590	
	Fixed-mounted	H mm D mm	434 291	434 291	434 291	434 291	
	Withdrawable	H mm D mm	465.5 471	465.5 471	465.5 471	465.5 471	465.5 471



Electronic Trip Units for 3WL circuit breakers

Type	ETU15B ¹⁾	ETU25B	ETU27B	ETU45B	ETU76B
Overload protection	✓	✓	✓	✓	✓
Short-time delayed short-circuit protection	--	✓	✓	✓	✓
Instantaneous short-circuit protection	✓	✓	✓	✓	✓
Neutral conductor protection	--	--	✓	✓	✓
Ground-fault protection	--	--	✓	□	□
Zone Selective Interlocking	--	--	--	□	□
LCD, 4-line	--	--	--	□	--
LCD, graphic	--	--	--	--	✓
Communication	--	--	--	□	□
Metering function <i>Plus</i>	--	--	--	□	□
Selectable parameter sets	--	--	--	--	✓
Parameters freely programmable	--	--	--	--	✓
CubicleBUS	--	--	--	✓	✓

✓ Standard
-- Not available
□ Optional

¹⁾ ETU15B cannot be used with 3WL circuit breakers, size III.

3WL air circuit breakers/non-automatic air circuit breakers according to UL 489 up to 5000 A, see [Catalog LV 16](#).

Breaking capacity

Size	I			II			III				
Type	3WL11			3WL12			3WL13				
Breaking capacity	N	S	H	N	S	H	C	H	C	C	
Rated short-circuit breaking capacity											
Rated operational voltage U_e Up to 415 V AC											
I_{cu}	kA	55	66	85	66	80	100	130	100	150	130
I_{cs}	kA	55	66	85	66	80	100	130	100	150	130
I_{cm}	kA	121	145	187	145	176	220	286	220	330	286
Rated operational voltage U_e Up to 500 V AC											
I_{cu}	kA	55	66	85	66	80	100	130	100	150	130
I_{cs}	kA	55	66	85	66	80	100	130	100	150	130
I_{cm}	kA	121	145	187	145	176	220	286	220	330	286
Rated operational voltage U_e Up to 690 V AC											
I_{cu}	kA	42	50	66	50	75	85	100	85	150	130
I_{cs}	kA	42	50	66	50	75	85	100	85	150	130
I_{cm}	kA	88	105	145	105	165	187	220	187	330	286
Rated operational voltage U_e Up to 1000 V/1150 V AC											
I_{cu}	kA	--	--	50 ⁹⁾	--	--	50	--	50	70 ⁴⁾	70 ⁴⁾
I_{cs}	kA	--	--	50 ⁹⁾	--	--	50	--	50	70 ⁴⁾	70 ⁴⁾
I_{cm}	kA	--	--	105 ⁹⁾	--	--	105	--	105	154 ⁴⁾	154 ⁴⁾
Rated short-time withstand current I_{cw} of the circuit breakers ³⁾											
0.5 s	kA	55	66	75	66	80	100	100	100	100	100
1 s	kA	42	50	66	55	66	80	100	100	100	100
2 s	kA	29.5	35	46	39	46	65 ^{1)/70²⁾}	70	80	80	80
3 s	kA	24	29	44	32	44	50 ^{1)/65²⁾}	65	65	65	65
Rated short-circuit breaking capacity I_{cc} of the non-automatic air circuit breakers											
Up to 500 V AC	kA	55	66	75	66	80	100	130	100	100	100
Up to 690 V AC	kA	42	50	66	50	75	85	100	85	100	100
Up to 1000 V /1150 V AC	kA	--	--	50 ⁹⁾	--	--	50 ⁴⁾	--	50 ⁴⁾	70 ⁴⁾	70 ⁴⁾
Size	I			II							
Type	3WL11			3WL12							
Breaking capacity	DC			DC							
Rated short-circuit breaking capacity											
Up to 220 V DC I_{cc}	kA	20	35								
Up to 300 V DC I_{cc}	kA	20	30								
Up to 600 V DC I_{cc}	kA	20	25								
Up to 1000 V DC I_{cc}	kA	20	20								
Rated short-time withstand current I_{cw}											
0.5 s	kA	--	--								
1 s	kA	20	35 ^{5)/30^{6)/25^{7)/20⁸⁾}}}								
2 s	kA	--	--								
3 s	kA	--	--								

- N** Circuit breakers with ECO breaking capacity N
- S** Circuit breakers with standard breaking capacity S
- H** Circuit breakers with high breaking capacity H
- C** Circuit breakers with very high breaking capacity C
- DC** Non-automatic air circuit breakers with DC breaking capacity

These breaking capacities are indicated in the corresponding tables by the symbols shown on orange backgrounds.

- 1) Size II with $I_{n \max} \leq 2500$ A.
- 2) Size II with $I_{n \max} = 3200$ A and $I_{n \max} = 4000$ A.
- 3) At a rated voltage of ≥ 690 V, the I_{cw} value of the circuit breaker cannot be greater than the I_{cu} or I_{cs} value at 690 V.
- 4) Rated operational voltage $U_e = 1150$ V.
- 5) At $U_e = 220$ V DC.

Abbreviations* (functions)	English long text	Explanation
L	Long Time Delay	Overload protection
S	Short Time Delay	Short-circuit protection (short-time delayed)
I	Instantaneous	Short-circuit protection (instantaneous)
N	Neutral Protection	Neutral conductor protection
G	Ground Fault	Ground-fault protection

* Designations according to IEC 60947-2, Appendix K.

- 6) At $U_e = 300$ V DC.
- 7) At $U_e = 600$ V DC.
- 8) At $U_e = 1000$ V DC.
- 9) Values also apply to 690 V + 20 % version with Z-option "A16".

3WL Air Circuit Breakers

Introduction

3WL air circuit breakers:

3WL air circuit breakers are extremely flexible in use and offer consistent communication capability. With the 3WL circuit breakers, just three sizes cover a performance range of 630 A to 6300 A. All models are characterized by the same design, the same operation and the same comprehensive accessories.

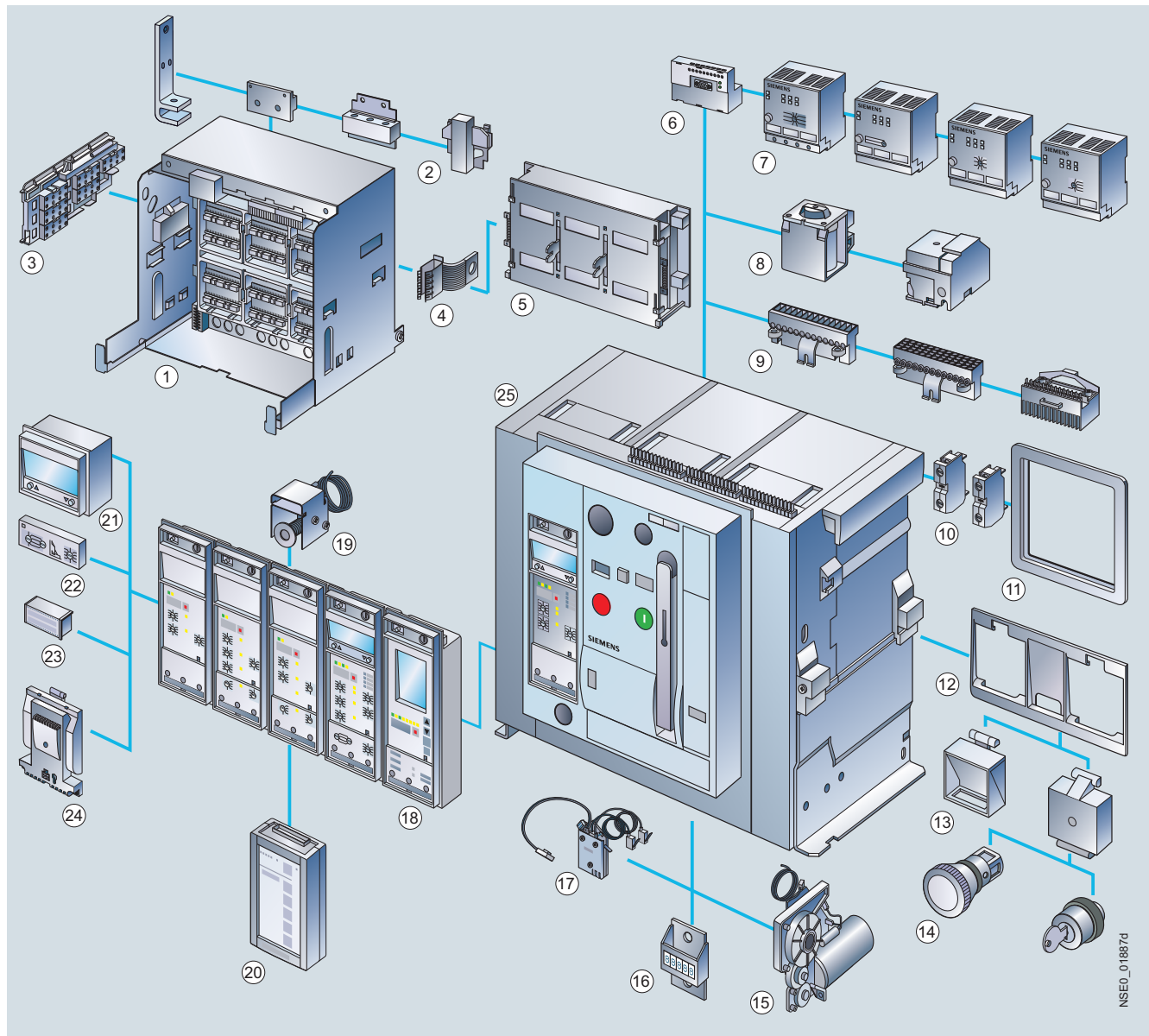

NSE0_01887d

- | | |
|---|---|
| ① Guide frame | ⑩ Auxiliary switch block |
| ② Main circuit connection, front, flange, horizontal, vertical | ⑪ Door sealing frame |
| ③ Position signaling switch | ⑫ Interlocking set for mechanical on/off |
| ④ Grounding connection, leading | ⑬ Transparent panel, function insert |
| ⑤ Shutters | ⑭ EMERGENCY-STOP pushbutton, key operated |
| ⑥ COM15 PROFIBUS module or COM16 MODBUS module | ⑮ Motorized operating mechanism |
| ⑦ External Cubicle BUS modules | ⑯ Operating cycles counter |
| ⑧ Closing coil, auxiliary release | ⑰ Breaker Status Sensor (BSS) |
| ⑨ Auxiliary conductor plug-in system | ⑱ Protective devices with device holder, Electronic Trip Unit (ETU) |
| ⑩ Auxiliary switch block | ⑲ Remote reset solenoid |
| ⑪ Door sealing frame | ⑳ Breaker Data Adapter (BDA Plus) |
| ⑫ Interlocking set for mechanical on/off | ㉑ Four-line display |
| ⑬ Transparent panel, function insert | ㉒ Ground-fault protection module |
| ⑭ EMERGENCY-STOP pushbutton, key operated | ㉓ Rating plug |
| ⑮ Motorized operating mechanism | ㉔ Metering function module |
| ⑯ Operating cycles counter | ㉕ Circuit breaker |
| ⑰ Breaker Status Sensor (BSS) | |
| ⑱ Protective devices with device holder, Electronic Trip Unit (ETU) | |
| ⑲ Remote reset solenoid | |
| ⑳ Breaker Data Adapter (BDA Plus) | |
| ㉑ Four-line display | |
| ㉒ Ground-fault protection module | |
| ㉓ Rating plug | |
| ㉔ Metering function module | |
| ㉕ Circuit breaker | |

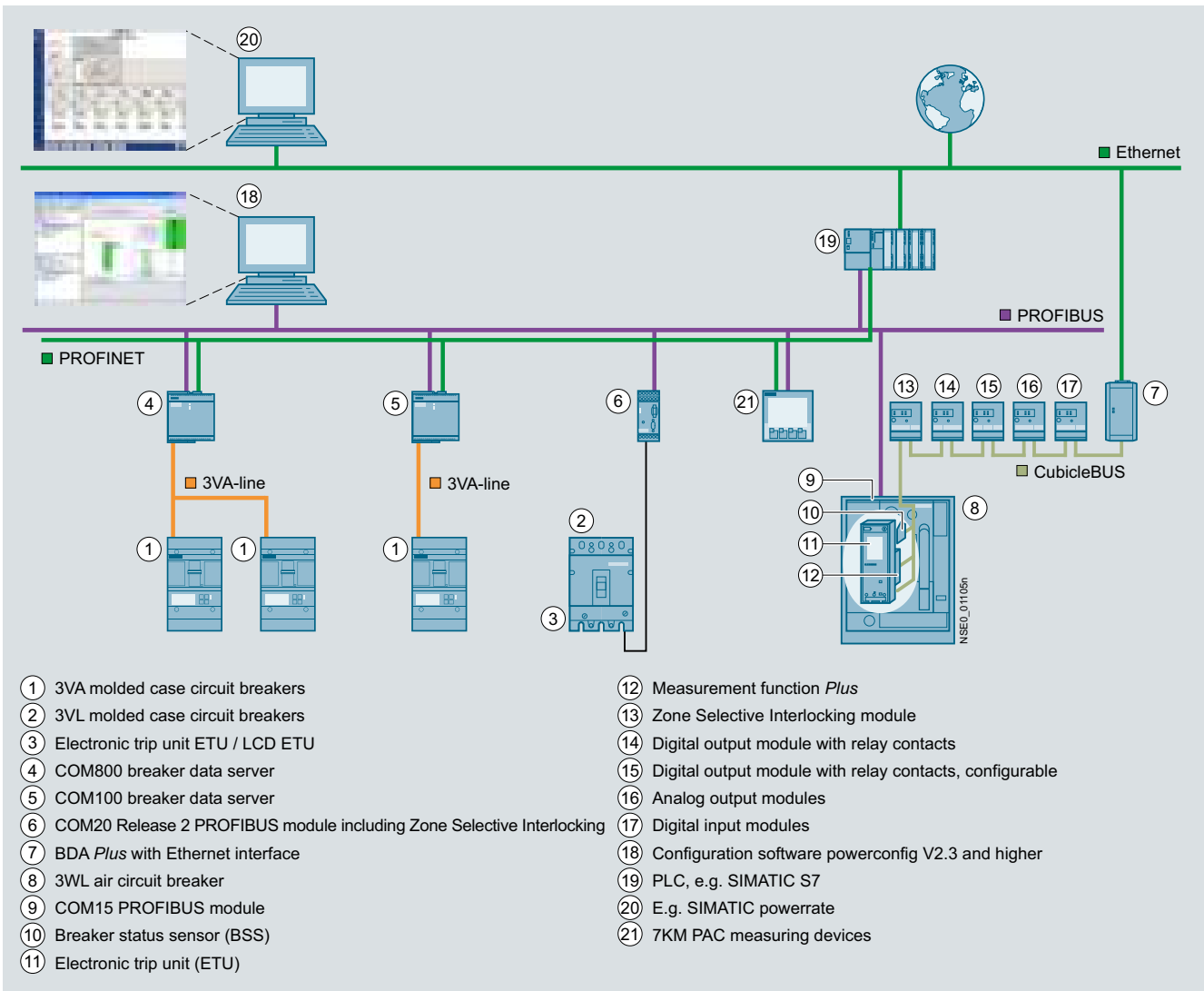
Communication-capable circuit breakers (with ETU45B or ETU76B Electronic Trip Unit)

3WL Air Circuit Breakers

Introduction

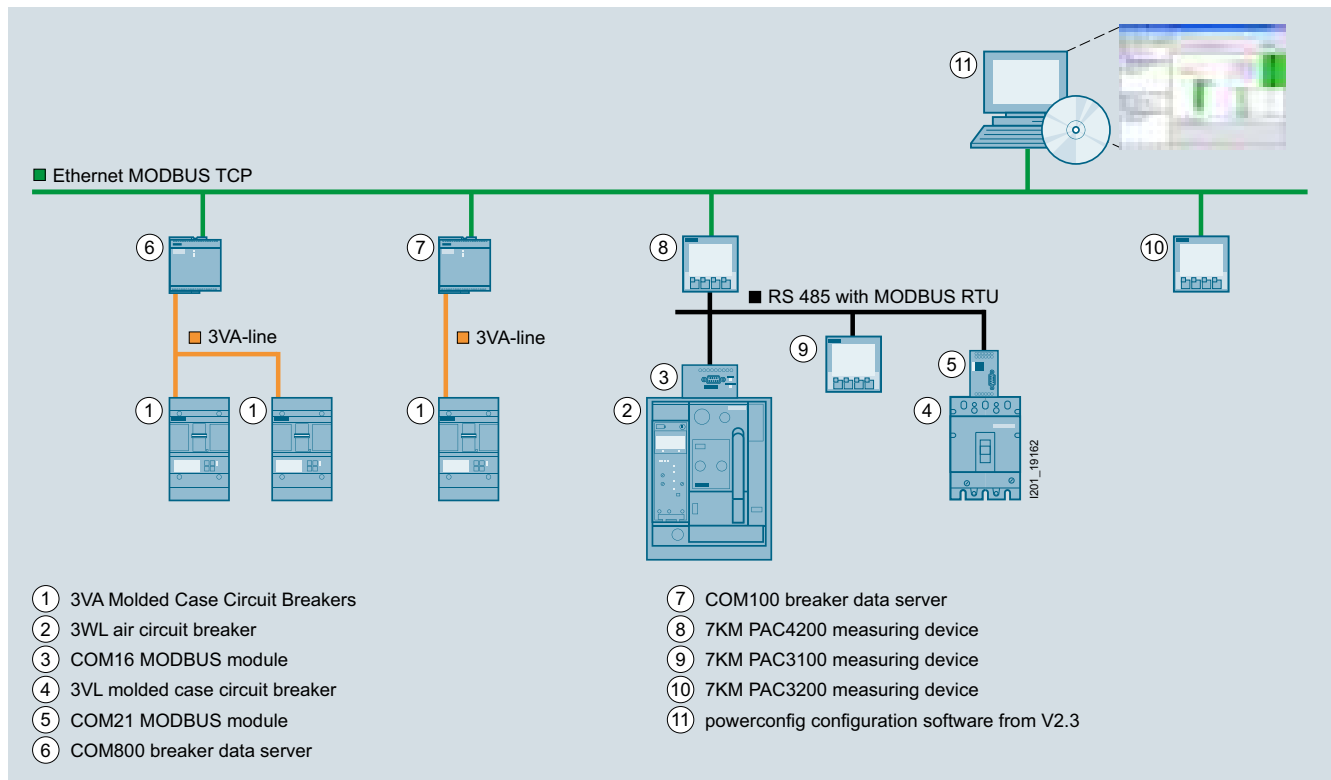

Features

- Coordinated communication concept using the PROFIBUS DP or MODBUS, ranging from 16 A to 6300 A with 3VL molded case circuit breakers and 3WL air circuit breakers
- The high level of modularity of circuit breakers and accessories allows easy retrofitting of all communication components
- Significant additional benefits for the switchgear due to the possibility of linking up external input and output modules to the circuit breaker-internal **CubicleBUS** of the 3WL air circuit breaker
- Innovative software products for parameterization, operation, monitoring, and diagnostics of circuit breakers, both locally or via PROFIBUS DP, MODBUS or Ethernet/Intranet/Internet
- Complete integration of the circuit breakers into the Totally Integrated Power and Totally Integrated Automation solutions

Communication:

- For air circuit breakers with optional communication function (ETU45B or ETU76B Electronic Trip Units), [see Catalog LV 10](#)
- For accessories, [see Catalog LV 10](#)
- For more information, [see also Catalog LV 10, chapters "Measuring Devices and Power Monitoring" and "Software"](#)

Benefits

Low space requirements

The 3WL air circuit breakers require very little space. Size I devices (up to 2000 A) fit into a 400 mm wide switchgear panel. Size III devices (up to 6300 A) are the smallest of their kind and with their construction width of 704 mm fit into an 800 mm wide switchgear panel.

Modular design

Components such as auxiliary releases, motorized operating mechanisms, overcurrent releases, current transformers, auxiliary circuit signaling switches, automatic reset devices, interlocks and engagement operating mechanisms can all be exchanged or retrofitted at a later stage, thus allowing the circuit breaker to be adapted to new, changing requirements.

The main contact elements can all be replaced in order to increase the endurance of the circuit breaker.

Retrofittable modules for overcurrent release

Modularity is one of the main features of the new 3WL air circuit breakers.

Special LCDs, ground-fault modules, rating plugs and communication modules for the overcurrent releases are available for fast and easy retrofitting and adaptation to changing requirements.

Communication/metering functions

The use of modern communication-capable circuit breakers opens up completely new possibilities in terms of start-up, parameterization, diagnostics, maintenance and operation. This allows many different ways of reducing costs and improving productivity in industrial plants, buildings and infrastructure projects:

- Fast and reliable parameterization
- Timely information and response can prevent plant stoppages
- Effective diagnostics management
- Measured values are the basis for efficient load management, for drawing up power demand profiles and for allocating power to cost centers

- Preventive maintenance reduces the risk of expensive plant downtimes
- Metering function with a very wide range of measured values, such as current, voltage, energy, power etc.
- Can be used in 690 V networks

Application

- As incoming-feeder, distribution, coupling, and outgoing-feeder circuit breakers in electrical installations
- For switching and protecting motors, capacitors, generators, transformers, busbars and cables

When connected to an electronic I&C system, the air circuit breakers offer a wide range of options for monitoring network events.

Air circuit breakers belong to the SENTRON product family of protection, switching, measuring and monitoring devices and can be used in applications between 16 A and 6300 A.

The AC devices are available as circuit breakers and non-automatic air circuit breakers. DC devices are only available as non-automatic air circuit breakers.

Standards

3WL circuit breakers comply with:

- IEC 60947-2
- IEC 60947-2 Appendix F / CISPR 11/22 Class B
- Climate-proof according to IEC 60068-2-30.

Versions with UL 489 also available, [see Catalog LV 16](#).

Conductor cross-sections

Size	I					II				
	Type	Up to 3WL11 10	3WL11 12	3WL11 16	3WL11 20	3WL12 08	3WL12 10	3WL12 12	3WL12 16	3WL12 20
Permissible load for withdrawable versions at rear horizontal main connections	• Up to 55 °C (Cu bare)	A 1000	1250	1600	2000	800	1000	1250	1600	2000
	• Up to 60 °C (Cu bare) ¹⁾	A 1000	1250	1600	1930	800	1000	1250	1600	2000
	• Up to 70 °C (Cu painted black) ¹⁾	A 1000	1210	1490 ²⁾	1780	800	1000	1250	1600	2000
Main conductor minimum cross-sections	• Copper bars, bare	Unit(s) 1 x mm ² 60 x 10	2 x 40 x 10	2 x 50 x 10	3 x 50 x 10	1 x 50 x 10	1 x 60 x 10	2 x 40 x 10	2 x 50 x 10	3 x 50 x 10
	• Copper bars, painted black	Unit(s) 1 x mm ² 60 x 10	2 x 40 x 10	2 x 50 x 10	3 x 50 x 10	1 x 50 x 10	1 x 60 x 10	2 x 40 x 10	2 x 50 x 10	3 x 50 x 10

Size	II			III			
	Type	3WL12 25	3WL12 32	3WL12 40 ³⁾	3WL13 40	3WL13 50	3WL13 63 ³⁾
Permissible load for withdrawable versions at rear horizontal main connections	• Up to 55 °C (Cu bare)	A 2500	3200	3950 ⁴⁾	4000	5000	5920
	• Up to 60 °C (Cu bare) ¹⁾	A 2500	3020	3810	4000	5000	5810
	• Up to 70 °C (Cu painted black) ¹⁾	A 2280	2870	3600	4000	5000	5500
Main conductor minimum cross-sections	• Copper bars, bare	Unit(s) 2 x mm ² 100 x 10	3 x 100 x 10	4 x 120 x 10	4 x 100 x 10	6 x 100 x 10	6 x 120 x 10
	• Copper bars, painted black	Unit(s) 2 x mm ² 100 x 10	3 x 100 x 10	4 x 100 x 10 ⁵⁾	4 x 100 x 10	6 x 100 x 10	6 x 120 x 10

¹⁾ ETU76B with graphics display can be used up to max. 55 °C.

²⁾ At breaking capacity H: 1600 A up to 70 °C.

³⁾ With rear vertical connections

⁴⁾ Size II, 3-pole, in fixed-mounted version

⁵⁾ Minimum main conductor cross-sections for 4-pole withdrawable circuit breakers: 4 x 120 mm x 10 mm

3WL Air Circuit Breakers

3WL air circuit breakers/non-automatic air circuit breakers up to 6300 A (AC), IEC

General data

Design

	Circuit breaker rated current $I_{n \max}$ (A)	Breaking capacity I_{cu} at 500 V AC (kA) or I_{cc} at 300 V DC (kA)	Dimensions		
			Fixed-mounted, 3- /4-pole	With- drawable 3- /4-pole	
Size III			704 / 914	704 / 914	Width
	434 / 434		460 / 460	Height	
	291 / 291		385 / 385	Depth	
Size II			460 / 590	460 / 590	Width
	434 / 434		460 / 460	Height	
	291 / 291		385 / 385	Depth	
	320 / 410		320 / 410	Width	
	434 / 434		460 / 460	Height	
	291 / 291		385 / 385	Depth	
Size I			320 / 410	320 / 410	Width
	434 / 434		460 / 460	Height	
	291 / 291		385 / 385	Depth	

The dimension for the depth of the circuit breaker is from the circuit breaker rear to the inner surface of the closed switchgear door.

NSE0_00887q

Overview of 3WL circuit breakers/non-automatic air circuit breakers

Versions

- Rated currents: 630 A to 6300 A
- 3 sizes for different rated current ranges (see illustration above)
- 3 and 4-pole versions
- Rated operational voltage up to 690 V AC and 1000 V DC. Special versions up to 1000 V AC and 1150 V AC available
- 4 different breaking capacities from 55 kA to 150 kA for AC applications and one breaking capacity for DC applications

The 3WL circuit breakers are supplied complete with operating mechanism (manual operating mechanism with mechanical closing), electronic trip unit and auxiliary switches (2 NO contacts + 2 NC contacts in the standard version), and can be equipped with auxiliary trip units.

Installation methods

Fixed-mounted or withdrawable versions.

Ambient temperatures

The 3WL circuit breakers are climate-proof according to IEC 60068-2-30. They are intended for use in enclosed areas where no severe operating conditions (e.g. dust, corrosive vapors, damaging gases) are present.

When installed in dusty and damp areas, suitable enclosures must be provided.

Coordinated dimensions

The dimensions of 3WL circuit breakers only differ in terms of the width of the device which depends on the number of poles and the size.

Due to the nature of the design, the dimensions of devices with a withdrawable version are determined by the dimensions of the guide frames, which are slightly larger.

Non-automatic air circuit breakers

One special version of circuit breaker is utilized as a non-automatic air circuit breaker. The non-automatic air circuit breakers are designed without an electronic trip system and do not perform any protection functions for the system.

One potential application is the use as a bus coupler in systems with parallel feed-ins.

The versions and features can be selected according to those of the circuit breakers.

Operating mechanisms

The circuit breakers are available with various optional operating mechanisms:

- Manual operating mechanism with mechanical closing (standard design)
- Manual operating mechanism with mechanical and electrical closing
- Motorized operating mechanism with mechanical and electrical closing

The operating mechanisms with electrical closing can be used for synchronization tasks.

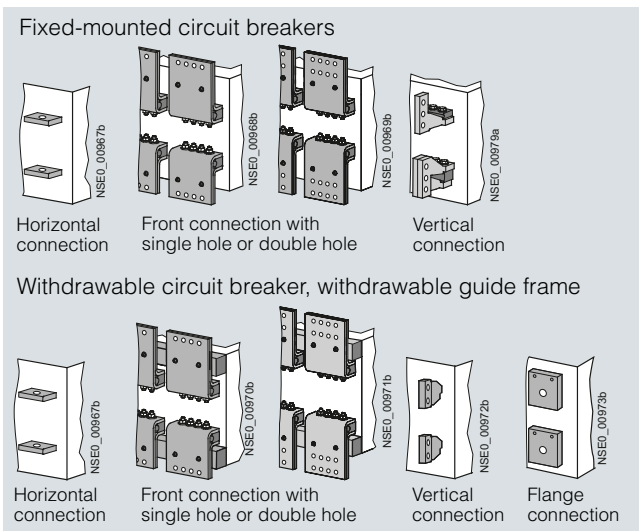

Main circuit connections – connection types

Main circuit connections

All circuit breakers are equipped with horizontal main circuit connections on the rear for up to 5000 A as standard (horizontal connection to busbars). Exception: Circuit breakers of size II with max. rated current 4000 A.

Circuit breakers with a max. rated current of 6300 A and circuit breakers of the size II with a max. rated current of 4000 A are equipped with vertical main circuit connections (for upright busbars).

The following options are available, with all combinations of top and bottom connections possible:

- Accessible from the front, single hole (for vertically installed busbars)
- Accessible from the front, double hole (holes according to DIN 43673) (for vertically installed busbars)
- At the rear, vertical (for vertically installed busbars)
- Connecting flange (for direct connection to guide frames up to 4000 A)

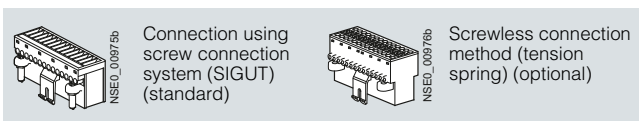

Connection options for auxiliary circuit connections

Auxiliary circuit connections

The type of connection for the auxiliary switches depends on the type of installation:

- Withdrawable version: The internal auxiliary switches are connected to the male connector on the switch side. When fully inserted, the connector makes a connection with the sliding contact module (see the graphic "Guide Frame" in "Design") in the guide frame. Various adapters can then be used to complete the wiring (see the graphic "Connection options for auxiliary circuit connections")
- Fixed-mounted version: In this case the auxiliary supply connectors are engaged directly onto the circuit breaker. The connectors are equipped with coding pins that prevent them being mistakenly interchanged

Operator panel

The operator panel is designed to protrude from a cutout in the door providing access to all control elements and displays with the control cabinet door closed. The operator panels for all circuit breakers (fixed-mounted/withdrawable versions, 3-/4-pole) are identical. The operator panel ensures degree of protection IP41.

Safety and reliability

To protect the circuit breakers and system against unauthorized switching and to protect the maintenance and operator personnel, the system contains many locking devices. Others can be retrofitted.

Other safety features include:

- Infeed from above or below, as required
- Locking of the guide frame with the circuit breaker removed, as standard
- Locking of the withdrawable circuit breaker against movement, as standard
- High degree of protection with cover IP55
- Mechanical reclosing lockout after overload or short-circuit tripping as standard
- The circuit breaker is always equipped with the required number of auxiliary supply connectors

Standard version

3WL circuit breakers are equipped with the following features as standard:

- Mechanical ON and OFF pushbutton
- Manual operating mechanism with mechanical closing
- Switching position indication
- Ready-to-close indicator
- Store status indicator
- Auxiliary switch 2 NO + 2 NC
- Rear horizontal main circuit connections for fixed-mounted and withdrawable versions up to 5000 A, and rear vertical main circuit connections for 6300 A applications and size II with 4000 A
- For 4-pole circuit breakers, the fourth pole (N) is installed on the left and is 100 % loadable with the rated current
- Contact erosion indicator for the main contacts
- Auxiliary circuit plug-in system with SIGUT screw terminals. Delivery inclusive of all auxiliary circuit connectors as per internal equipment including coding device for the prevention of incorrect installation of auxiliary supply connectors for fixed-mounted circuit breakers
- Mechanical "tripped" indicator for electronic trip system
- Mechanical reclosing lockout after tripping operation
- Operator panel cannot be taken off with the circuit breaker in the ON position

Additional features of the withdrawable version:

- Main contacts: Laminated receptacles in the guide frame, blade contacts on the withdrawable circuit breaker
- Position indicator in the operator panel of the withdrawable circuit breaker
- Captive manual crank handle for moving the withdrawable circuit breaker
- Guide frame with guide rails for easy moving of the withdrawable circuit breaker
- The withdrawable circuit breaker can be locked to prevent it being pushed out of position
- The withdrawable circuit breaker cannot be moved when it is in the ON position
- Coding of the rated current between the guide frame and the withdrawable circuit breaker.

Standards

3WL circuit breakers comply with:

- IEC 60947-2
- Climate-proof according to IEC 60068-2-30

Versions acc. to UL 489 also available, see [Catalog LV 16](#).

Further standards, see www.siemens.com/lowvoltage/product-support or www.siemens.com/lowvoltage/configurators.

3WL Air Circuit Breakers

3WL air circuit breakers/non-automatic air circuit breakers up to 6300 A (AC), IEC

General data

Withdrawable short-circuit, grounding, and bridging units

Portable positively-driven grounding and short-circuit devices are used for the disconnected system sections to verify isolation from the supply at the workplace.

Withdrawable grounding units allow simple and comfortable grounding. They are simply inserted into the guide frames in place of the corresponding withdrawable circuit breakers. This ensures that these devices are always first connected with the grounding electrode and then with the components to be grounded.

The grounding contacts are fitted to the side of the breaker enclosure and establish the connection when inserted into the guide frame.

Short-time current of the grounding contact	kA	15 (500 ms)
Rated operational voltage	V	1000 (690 for size I)
Standards		DIN VDE 0683

All withdrawable contacts are short-circuited and grounded on delivery.

Qualified electricians can easily convert them to withdrawable bridging units by following the enclosed instructions.

In addition, the withdrawable unit can be adapted to various rated currents of one size.

Withdrawable short-circuit and grounding unit

The withdrawable short-circuit and grounding unit consists of a breaker enclosure with blade contacts which are connected with the short-circuiting link.

Depending on the version, the short-circuiting links are arranged at the top or bottom. The grounding and short-circuit connections are established when the device is inserted.

It must be ensured that the side to be short-circuited and grounded is not live. For this reason it is recommended that the withdrawable unit is only cranked in when the door is closed.

Withdrawable bridging unit

The withdrawable bridging unit consists of a breaker enclosure in which all disconnection components and the operating mechanism have been replaced with simple connections between the upper and lower contacts.

Auxiliary releases

Up to two auxiliary releases can be installed at the same time. The following are available for selection:

1 shunt release
or 1 undervoltage release
or 2 shunt releases
or 1 shunt release
+ 1 undervoltage release

Signaling switch for auxiliary releases

One signaling contact is used for each auxiliary release to determine the positions of the auxiliary releases.

Shunt releases

When the operational voltage is connected to the shunt release, the circuit breaker is opened immediately. The shunt release is available in the versions 5 % OP for overexcitation and 100 % OP for permanent excitation. This means that it is also possible to block the circuit breaker against being jogged into closing.

An energy storage device for shunt releases allows the circuit breaker to be opened even if the control voltage is no longer available.

Undervoltage releases

The undervoltage release causes the circuit breaker to be opened if the operational voltage falls below a certain value or is not applied. The circuit breaker cannot be closed manually or by means of an electrical ON command if the undervoltage release is not connected to the operational voltage. The undervoltage release has no delay as standard. A delay can be set by the customer in the range between $t_d < 80$ ms and $t_d < 200$ ms.

In addition, an undervoltage release with a delay in the range from 0.2 to 3.2 s is available.

Closing solenoid

The closing solenoid is used to close the circuit breaker electrically by means of a local electrical ON command or by remote means.

Motorized operating mechanism

The operating mechanism is used to load the storage spring automatically.

The operating mechanism is activated if the storage spring has been unloaded and the control voltage is available.

It is switched off automatically after loading. This does not affect manual operation of the storage spring.

Indicators, signals, and control elements

Motor cutout switch

Control switch for switching off the motorized operating mechanism (automatic loading).

Operating cycles counter

The motorized operating mechanism can be supplied with a 5-digit operating cycles counter. The display is incremented by "1" as soon as the storage spring is fully loaded.

Resetting of the manual tripped signal

When the circuit breaker has tripped, this is indicated by the protruding red mechanical tripped indicator on the ETU. When the mechanical tripped indicator is activated, the tripping solenoid and tripped signal are reset. If this manual display is to be reset remotely, the reset button can be equipped with a reset solenoid.

This option allows the circuit breaker to be reset both manually and electrically.

Automatic resetting of reclosing lockout

When the ETU is tripped, reclosing of the circuit breaker is prevented until the trip unit is either electrically or manually reset. If the "Automatic resetting of reclosing lockout" option is used, the pre-tensioned circuit breaker is ready to close immediately after tripping. Resetting the manual "tripped" indicator is not included in this option.

Tripped signaling switch

If the circuit breaker has tripped due to an overload, short-circuit, ground fault or extended protection function, the tripped signaling switch can indicate this. This signaling switch is available as an option. If the circuit breaker is used for communication, this option is supplied as standard.

Ready-to-close signaling switch

The 3WL circuit breakers are equipped with an optical ready-to-close indicator as standard. In addition, the ready-to-close status can be transmitted by means of a signaling switch as an option. If the switch is used for communication, this signaling switch is supplied as standard.

3WL Air Circuit Breakers

3WL air circuit breakers/non-automatic air circuit breakers up to 6300 A (AC), IEC

General data

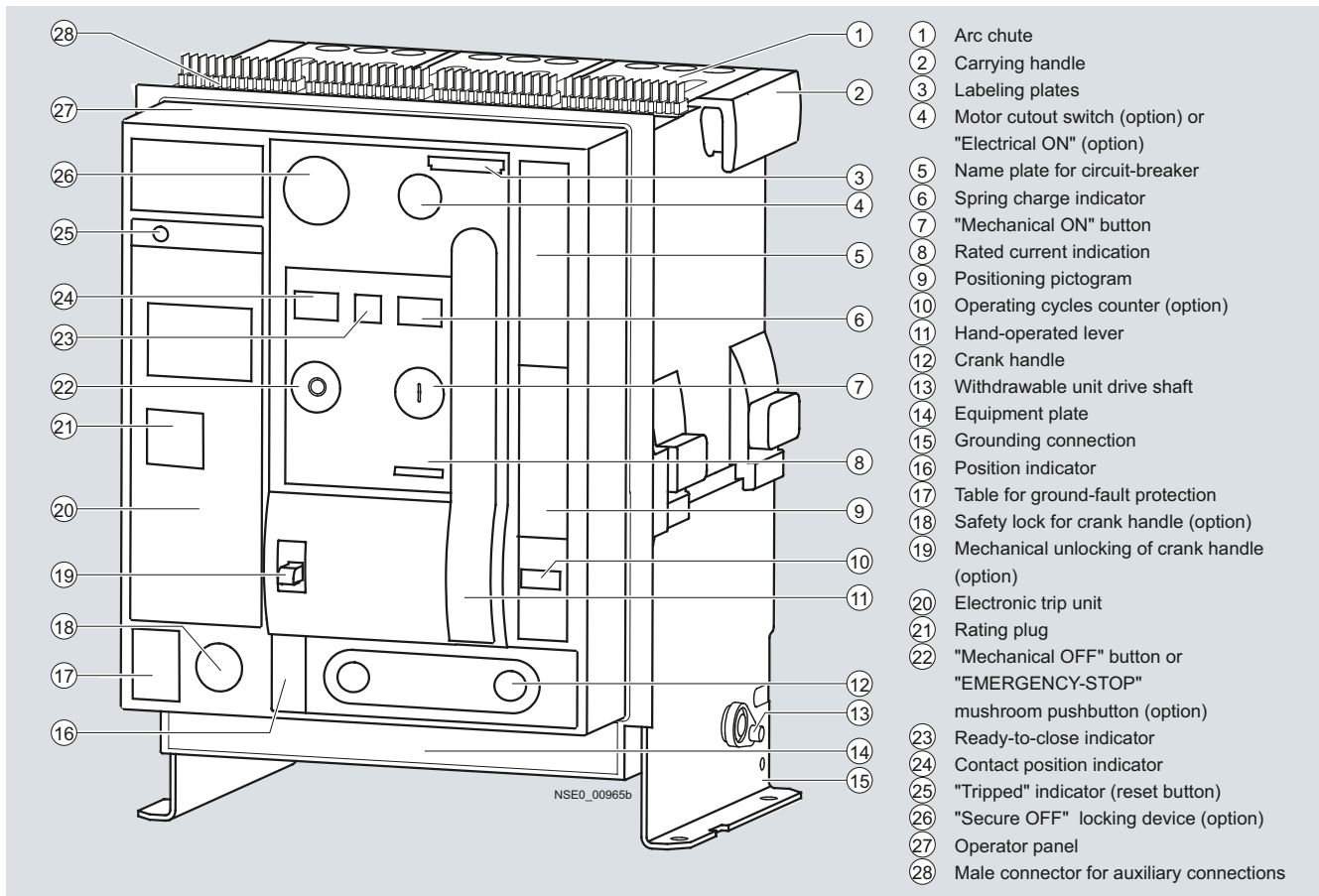
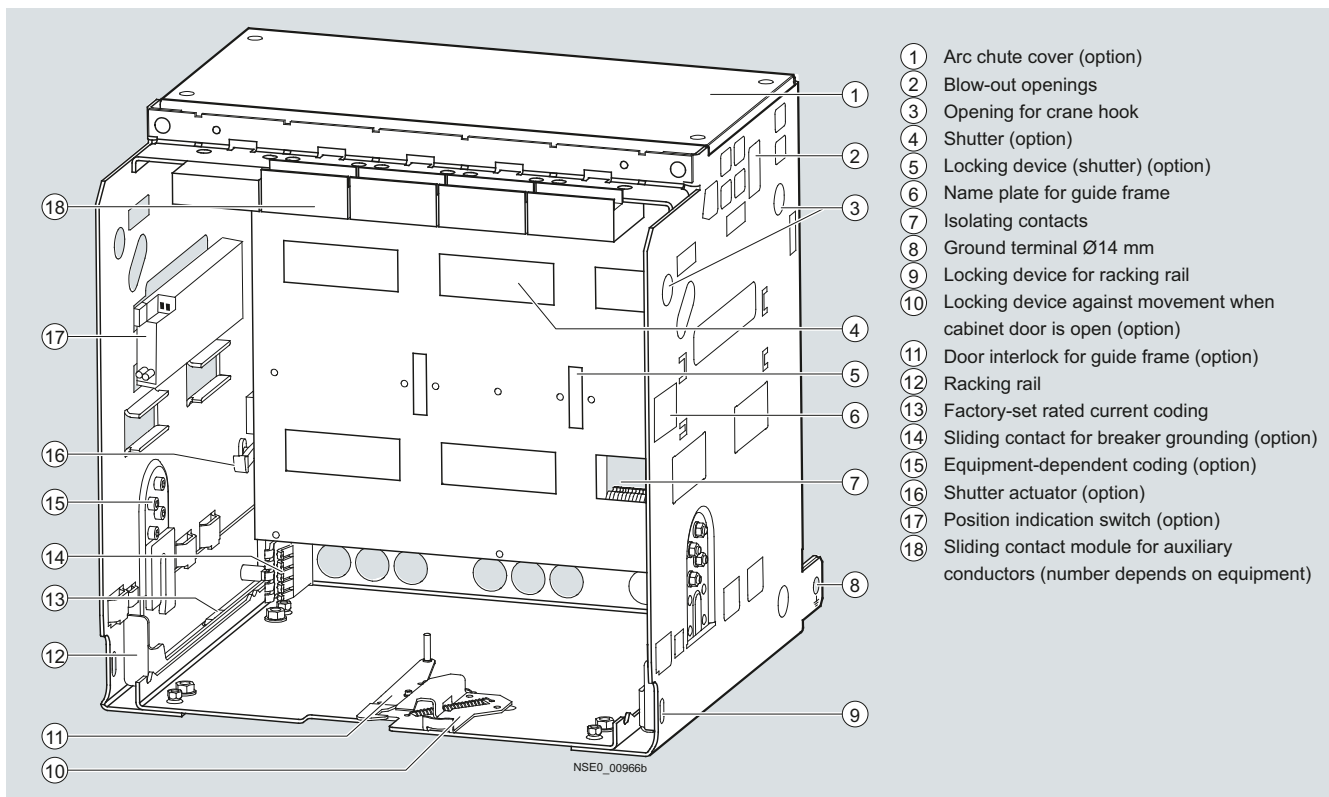
Circuit breakers**Guide frames**

3WL Air Circuit Breakers

3WL air circuit breakers/non-automatic air circuit breakers up to 6300 A (AC), IEC

General data

Locking devices

Locking device in OFF position

This function prevents closing of the circuit breaker and complies with the requirements for main switches to EN 60204 (VDE 0113) - disconnecter unit. This lockout only affects this circuit breaker.

If the circuit breaker is replaced, closing is no longer prevented unless the new circuit breaker is also protected against unauthorized closing.

To activate the locking device, the circuit breaker must be opened. The locking device is disabled when the circuit breaker is closed. The lock is only activated when the key is removed. The safety key can be removed only in the "OFF" position.

Locking device for "Electrical ON" (see graphic "Circuit breakers")

This prevents unauthorized electrical closing from the operator panel. Mechanical closing and remote closing remain possible. The lock is only activated when the key is removed.

Locking device for "Mechanical ON" (See graphic "Circuit breakers")

This prevents unauthorized mechanical closing. The mechanical ON button can only be activated if the key is inserted (key operation). Closing with the "Electrical ON" button and remote closing remain possible. The lock is only activated when the key is removed.

"Secure OFF" circuit breaker-independent locking device against unauthorized closing

This special breaker-independent function for withdrawable circuit breakers prevents closing and fulfills the requirements for main switches to EN 60204 (VDE 0113) – disconnecter unit. Unauthorized closing remains impossible even after the circuit breaker has been exchanged.

To activate the lock, the circuit breaker must be opened. The locking device is disabled when the circuit breaker is closed. The lock is only activated when the key is removed. The safety key can be removed only in the "OFF" position.

Locking device for crank handle

Prevents removal of the crank. The circuit breaker is protected against movement. The lock is only activated when the key is removed.

Locking device for "Mechanical OFF"

Prevents unauthorized mechanical opening from the operator panel. The "Mechanical OFF button" can only be activated if the key is inserted (key operation). Remote opening remains possible. The lock is only activated when the key is removed.

Locking device for hand-operated lever

The hand-operated lever can be locked with a padlock. The storage spring cannot be loaded manually.

Locking device against resetting the "tripped" indicator

A lockable cover prevents manual resetting of the "tripped" indicator after overcurrent tripping. This locking device is supplied together with the transparent cover option for electronic trip units.

Sealing devices

Sealing cap for "Electrical ON" button

The "Electrical ON button" is equipped with a sealing cap as standard.

Sealing cap for "Mechanical ON" and "OFF" button

The locking set contains covering caps which can be sealed.

Sealing device for electronic trip units

The transparent cover can be sealed. The parameter setting sections are covered to prevent unauthorized access. Openings allow access to the query and test button.

Locking mechanisms

Locking mechanism against movement for withdrawable circuit breakers when the control cabinet door is open

The crank handle is blocked when the control cabinet door is open and cannot be removed. The withdrawable circuit breaker cannot be moved. The lock only affects the inserted crank handle.

Locking of the control cabinet door

The control cabinet door cannot be opened if

- The fixed-mounted circuit breaker is closed (the blocking signal is transmitted via the Bowden cable) or
- The withdrawable circuit breaker is in the connected position

Blocking mechanism using "Mechanical ON" and "OFF" buttons

The "Mechanical ON" and "OFF" buttons are covered with a cap which only allows actuation with a tool. These covering caps are part of the interlocking set.

Optional equipment for guide frames

Shutters

The sealing strips of the shutter seal the laminated contacts of the guide frame when the withdrawable circuit breaker is removed and therefore implement touch protection.

The sealing strips can be manually opened using the strip levers.

The position of the sealing strips can be locked in various positions using padlocks for securing against tampering.

Rated current coding unit between circuit breaker and guide frame

Withdrawable circuit breakers and guide frames are equipped with a rated current coding unit as standard.

This ensures that only circuit breakers whose blade contacts are suited to the laminated contacts of the guide frame can be inserted into a guide frame (see diagram below).

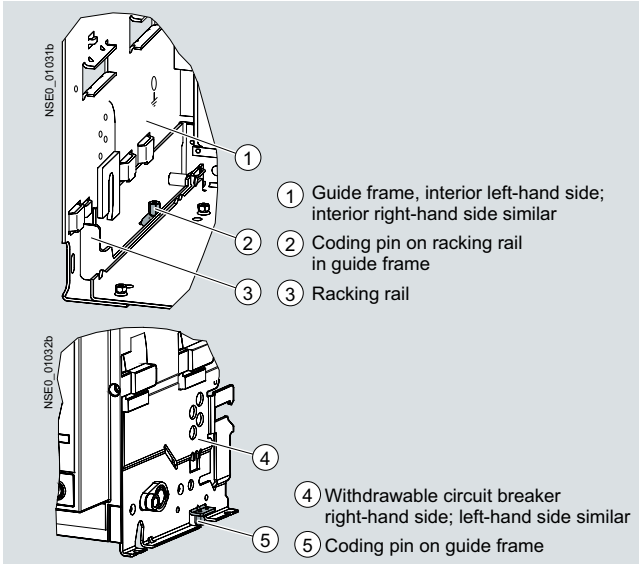

Rated current coding unit between circuit breaker and guide frame

Equipment-dependent coding

Withdrawable circuit breakers and guide frames can be retrofitted with an equipment-dependent coding unit.

This allows different designs of circuit breakers and guide frames to be uniquely assigned. If the circuit breaker and guide frame have been assigned different codes, the circuit breaker cannot be inserted.

36 different coding options can be selected.

Position signaling switches for guide frames

The guide frame can be equipped with position signaling switches. These can be used to determine the position of the circuit breaker in the guide frame.

Two versions are available:

- Option 1

Connected position	1 CO contact,
Test position	1 CO contact,
Disconnected position	1 CO contact
- Option 2

Connected position	3 CO contacts,
Test position	2 CO contacts,
Disconnected position	1 CO contact

Positions of the withdrawable circuit breaker in the guide frame

	Representation	Position indicator	Main circuit	Auxiliary circuit	Cabinet door	Shutters
Maintenance position			Disconnected	Disconnected	Open	Closed
Disconnected position			Disconnected	Disconnected	Closed	Closed
Test position			Disconnected	Connected	Closed	Closed
Connected position			Connected	Connected	Closed	Open

Phase barriers

The plant engineering company can manufacture phase barriers made of insulating material for the arcing fault barriers. The rear panel of the fixed-mounted circuit breakers or guide frames are equipped with guide grooves.

Arc chute cover

The arc chute cover is available as optional equipment for the guide frame. It protects switchgear components which are located directly above the circuit breaker.

Door sealing frame and cover

3WL circuit breakers have degree of protection IP20 as standard. However, if the switchgear is to be equipped with a higher degree of protection, a door sealing frame with IP41 and a cover with IP55 are available.

3WL Air Circuit Breakers

3WL air circuit breakers/non-automatic air circuit breakers up to 6300 A (AC), IEC

General data

Function

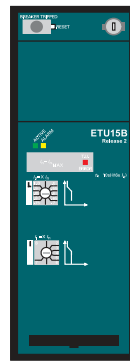

NSE0_00800b



NSE0_00811b

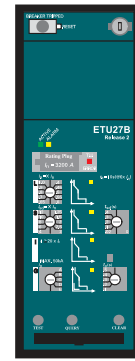

NSE0_00822b

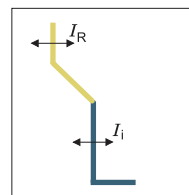

NSE0_00950c

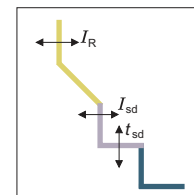

NSE0_00951b

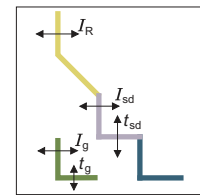

NSE0_00952b

ETU15B

ETU25B

ETU27B

Functions of the Electronic Trip Units

Basic protection functions

Function	Symbol	ETU15B	ETU25B	ETU27B
Overload protection	L	✓	✓	✓
Short-time delayed short-circuit protection	S	--	✓	✓
Instantaneous short-circuit protection	I	✓	✓	✓
Neutral conductor protection	N	--	--	✓
Ground-fault protection	G	--	--	✓

Additional functions

Neutral conductor protection (can be switched on/off)		--	--	✓
N-conductor protection adjustable		--	--	--
Short-time delay short-circuit protection (can be switched on/off)		--	--	--
Instantaneous short-circuit protection (can be switched on/off)		--	--	--
Thermal image can be switched on/off		--	--	--
Load monitoring		--	--	--
Short-time delayed short-circuit protection switchable to I^2t		--	--	--
Instantaneous short-circuit protection adjustable		✓	--	--
Overload protection switchable to I^4t		--	--	--
Overload protection can be switched on/off		--	--	--
Selectable parameter sets		--	--	--

Parameterization and display

Parameterization through rotary coding switches (10 steps)		✓	✓	✓
Parameterization through communication (absolute values)		--	--	--
Parameterization through user interface of ETU (absolute values)		--	--	--
Parameterization of the extended protection functions		--	--	--
LCD alphanumerical		--	--	--
LCD graphical		--	--	--

Metering function

Metering function <i>Plus</i>		--	--	--
-------------------------------	--	----	----	----

Communication

CubicleBUS		--	--	--
Communication through PROFIBUS DP		--	--	--
Communication through MODBUS		--	--	--
Communication via Ethernet		--	--	--

✓ Standard -- Not available □ Optional

Note

Detailed information about the functions of the Electronic Trip Units is given in the following.

3WL Air Circuit Breakers

3WL air circuit breakers/non-automatic air circuit breakers up to 6300 A (AC), IEC

General data

Electronic Trip Units (ETU)

The Electronic Trip Unit is controlled by a microprocessor and operates independently of an auxiliary voltage. It enables systems to be adapted to the different protection requirements of distribution systems, motors, transformers and generators.

Communication capability

The international standardized PROFIBUS DP or MODBUS can be used to transmit data such as current values, switching states, causes of tripping etc. to central computers.

Data acquisition and energy management are possible in conjunction with the metering function *Plus*.

An internal circuit breaker data bus allows switchboard panel communication between the circuit breaker and typical secondary devices in the circuit breaker section:

- Control of analog displays
- Facility to test the communication build-up with circuit breakers
- Display of tripping state and tripping reasons
- Input module for reading in further switchgear panel signals and for transmission of these signals to the PROFIBUS DP or MODBUS
- Various output modules for displaying measured values

This means that it is not only possible to monitor the device remotely, but also to transmit current values from the entire system and perform switching operations remotely.

I^2t and I^4t characteristic curves for overload protection

The best protection for the whole switchgear is achieved by setting the tripping characteristic curve to an optimum value. In order to achieve optimal discrimination for upstream fuses or medium voltage protection systems, the inclination of the characteristic curve can be selected for the overload range.

The overload protection L (long time protection) for the ETU45B and ETU76B Electronic Trip Units allows the curve to be switched between I^2t and I^4t characteristics.

The I^4t characteristic improves discrimination for downstream circuit breakers and fuses.

Electronic Trip Units ETU

Modularity has also been strictly emphasized during the development of the Electronic Trip Units. These are some of the modules which can be easily retrofitted at any time:

- Ground-fault protection module
- Communication
- Metering function
- Display
- Rated current module (rating plug)

This allows quick adaptation to new local mains conditions. In addition, innovative functions have been included in the ETUs.

Rated current module / rating plug

The rated current module is an exchangeable module which allows the user to reduce the rated device current so as to adapt it optimally to the plant; e.g. if a new plant section is put into operation. The rated current module must be selected to correspond to the rated current of the plant.

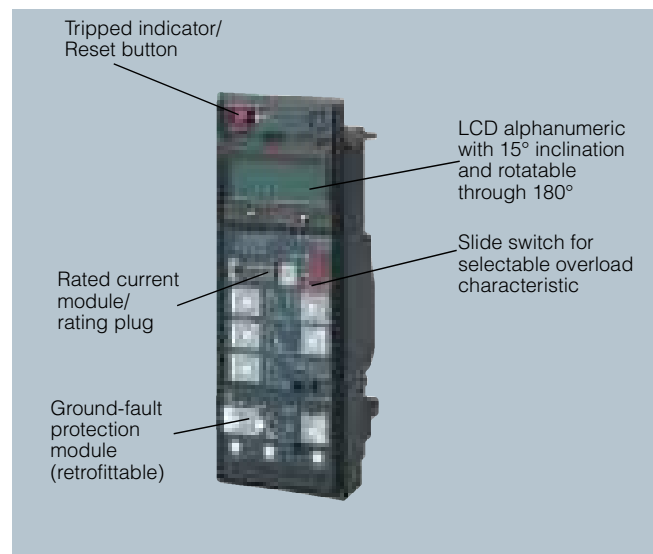

Example of configuration for ETU45B



Metering function *Plus*

Selectable parameters

In the case of quick changes of power supply conditions, e.g. for switchover from transformer to generator operation or if a section of the supply is disconnected when the shift changes, 3WL circuit breakers allow the relevant protection parameters to be quickly adapted to the new conditions. The ETU76B contains two independent tripping characteristics (parameter sets). The switchover is completed within 200 ms and is performed with the help of an external signal.

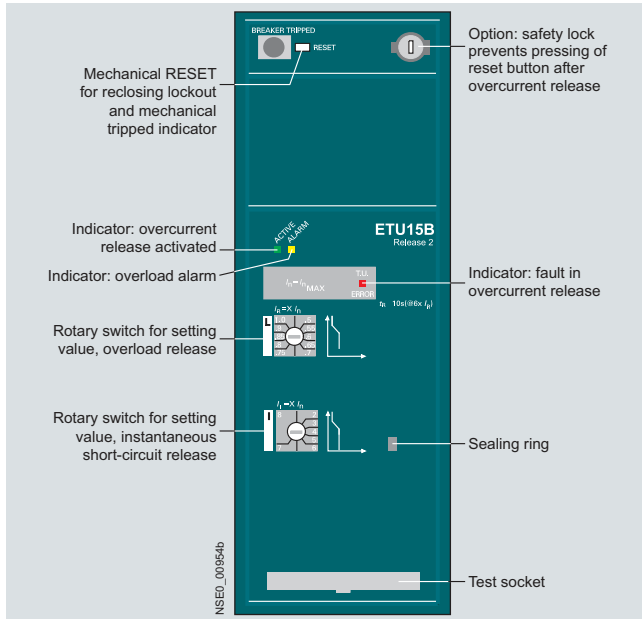
ETU15B Electronic Trip UnitApplication:

Simple building and system protection without time-selective coordination up to 4000 A.
Not to be used for size III.

Properties:

- Adjustable overload protection with I^2t characteristic with non-adjustable delay time $t_R = 10$ seconds at $6 \times I_R$
- Instantaneous short-circuit protection adjustable in the range $2 \dots 8 \times I_n$
- Overload display
- Protection function is set by means of the rotary coding switch

Technical details, see the table "Functional overview of the electronic trip system" under "Technical specifications"

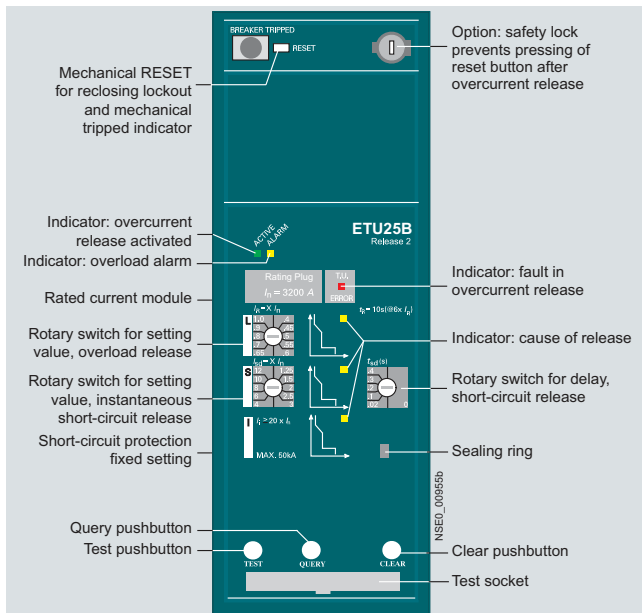
ETU25B Electronic Trip UnitApplication:

Classical building, motor and system protection with time-selective coordination for up to 6300 A

Properties:

- Adjustable overload protection with I^2t characteristic
Delay time $t_R = 10$ seconds at $6 \times I_R$
- Short-time delayable short-circuit protection adjustable in the range $1.25 \dots 12 \times I_n$ and
- Instantaneous short-circuit protection non-adjustable to $20 \times I_n$, max. 50 kA
- Can be adapted at any time to the required plant currents through exchangeable rated current module, thus ensuring overload protection in the range from 100 A to 6300 A
- Overload display
- Indicates the cause of tripping by means of an LED
- Test facility for the trip unit
- Protection function is set by means of the rotary coding switch

Technical details, see the table "Functional overview of the electronic trip system" under "Technical specifications"

3WL Air Circuit Breakers

3WL air circuit breakers/non-automatic air circuit breakers up to 6300 A (AC), IEC

General data

ETU27B Electronic Trip Unit

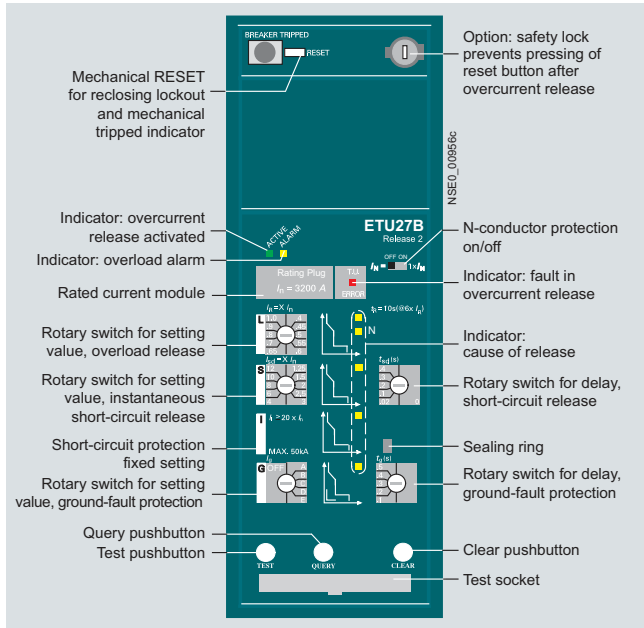

Application:

Classical building, motor and system protection with time-selective coordination for up to 6300 A.

Properties:

The same as ETU25B but also

- Connectable neutral conductor protection
- Permanently integrated ground-fault protection. Calculation of the ground-fault current through vectorial summation current formation

Technical details, see the table "Functional overview of the electronic trip system" under "Technical specifications"

ETU45B Electronic Trip Unit

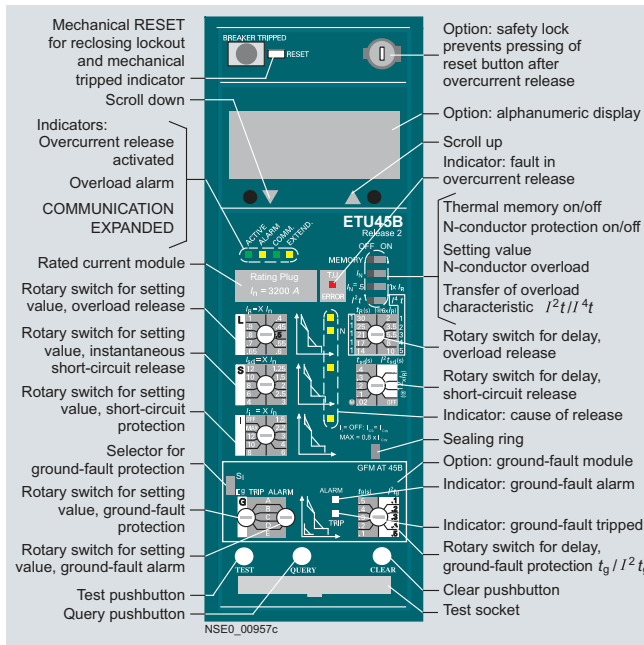

Application:

Low-cost all-round system for intelligent buildings and all types of industrial applications – **"CubicleBUS integrated"**

Properties:

The same as ETU25B but also

- Adjustable time-lag class for overload protection
- Selectable characteristic for overload and short-time delayed short-circuit range (current discrimination) for more accurate discrimination adaptation to upstream fuses and protective devices
- Thermal image as restart protection for tripped motor outgoing units
- Connectable and adjustable neutral conductor protection
- Modular ground-fault protection module with alarm and tripping functions which can be adjusted separately
- Communication interface, metering function *Plus*, optional connection of external modules or for retrofitting
- Storage of events and causes of tripping for specific fault analysis
- Extended protection functions possible with metering function
- Optional high-contrast display with viewing angle adjustment option
- The protection functions can be set by means of a rotary coding switch or slide switch

Technical details, see the table "Functional overview of the electronic trip system" under "Technical specifications"

ETU76B Electronic Trip Units

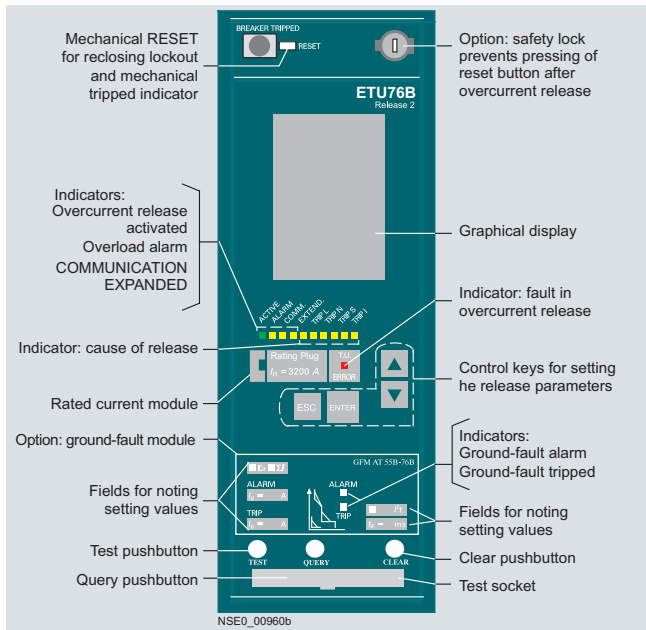

Application:

The multi-talent with graphical display for system analysis – "CubicleBUS integrated"

Properties:

The same as ETU45B but also including

- Two protection parameter sets which can be stored separately in the trip unit (switchover is performed by means of external signal)
- With overload protection which can be deactivated for use in modern drive engineering applications
- Adjustable delay of delayed short-circuit protection up to 4000 ms
- Neutral conductor protection adjustable up to I_N = 200 % I_N
- Setting of protection functions by means of Breaker Data Adapter (BDA *Plus*) or via communications interface
- Graphical display of all parameters and events/curve trends
- Graphics display with high contrast, backlit display, and sleep mode.

Technical details, see the table "Functional overview of the electronic trip system" under "Technical specifications".

Ground-fault protection

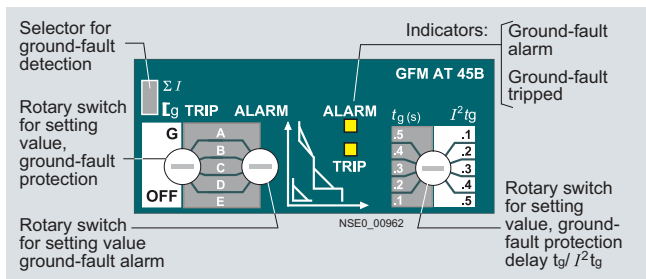

GFM AT 45B ground-fault module

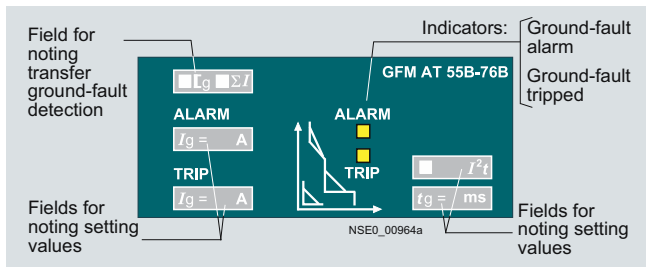

GFM AT 55B-76B ground-fault module

Ground-fault releases "G" sense fault currents that flow to ground and that can cause a fire in the plant. Multiple circuit breakers connected in series can have their delay times adjusted so as to provide graduated discrimination.

When setting the parameters for the Electronic Trip Unit it is possible to choose between "alarm" and "trip" in the event that the set current value is exceeded. The reason for tripping is indicated by means of an LED when the query button is activated.

The ETU45B and ETU76B Electronic Trip Unit versions can be retrofitted with a ground-fault protection module. This ground-fault protection function is integrated in ETU27B Electronic Trip Units.

3WL Air Circuit Breakers

3WL air circuit breakers/non-automatic air circuit breakers up to 6300 A (AC), IEC

General data

Measurement method

Vectorial summation current formation (measurement method 1)

The three phase currents and the N conductor current are measured directly.

The electronic trip unit determines the ground-fault current by means of vectorial summation current formation for the three phase currents and the N-conductor current.

Direct measurement of the ground-fault current (measurement method 2)

A standard current transformer with the following data is used for measurement of the ground-fault current: 1200 A/1 A, Class 1 (the internal load of the 3WL circuit breaker is 0.11 Ω). The current transformer can be installed directly in the grounded neutral point of a transformer.

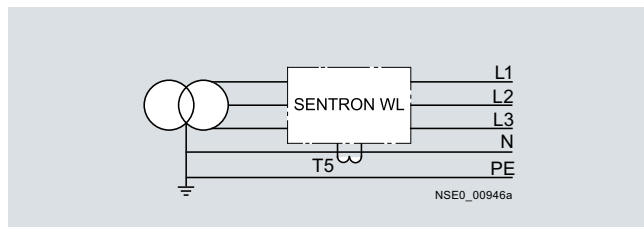

3-pole circuit breakers, current transformers in the N conductor

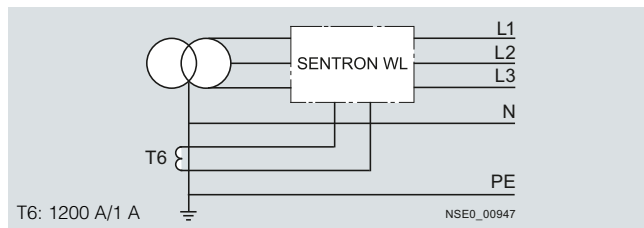

3-pole circuit breakers, current transformers in the grounded neutral point of the transformer

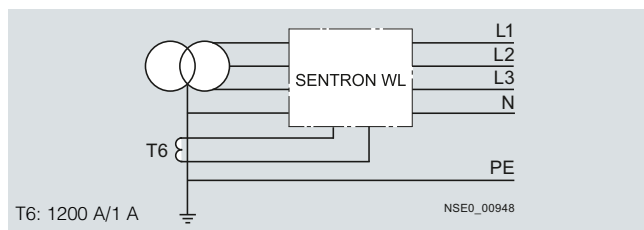

4-pole circuit breakers, current transformers in the grounded neutral point of the transformer

Setting

How the module is set depends on the measurement method used (see above):

Measurement method 1: in position ΣI

Measurement method 2: in position I_g

This setting can be implemented for the electronic trip unit version ETU76B with Menu/Comm.

Ground-fault protection with I^2t characteristic curve

With the exception of the ETU27B electronic trip unit, all versions of the ground-fault modules are supplied with an I^2t characteristic curve which can be activated.

Selection criteria for 3WL circuit breakers

Basic criteria for selecting circuit breakers are:

- **Max. short-circuit current** at place of installation of circuit breaker $I_k''_{max}$
This value determines the short-circuit breaking capacity or short-circuit current carrying capacity of the circuit breaker
- It is compared with the value I_{cu} , I_{cs} , I_{cw} of the circuit breaker and essentially determines the size of the circuit breaker. See Figure "Overview of 3WL circuit breakers/non-automatic air circuit breakers"
- **Rated current I_n** which is to flow through the branch circuit. This value must not be larger than the maximum rated current for the circuit breaker. The rated current for the 3WL circuit breaker is set with the rated current module. See Figure "Overview of 3WL circuit breakers/non-automatic air circuit breakers" in "Design"
- **Ambient temperature**
For the circuit breaker. This is usually the control cabinet internal temperature
- **Design of the circuit breaker**
- **Minimum short-circuit current**
Which flows through the switching device. The trip unit must still detect this value as a short-circuit and must respond by tripping

Protection functions of the circuit breaker.

These are defined by selection of the corresponding electronic trip unit, see the table "Functions of the electronic trip units" under "Functions"

3WL circuit breakers for DC applications

This version of the 3WL non-automatic air circuit breaker is suitable for direct current applications. The external protective device DIGmat S100 provides adjustable overload and short-circuit protection for the 3WL non-automatic air circuit breaker.

This is based on the measuring chain of a shunt resistor and the DIGmat S100 tripping unit. Shunt resistors are available for 1000 A, 2000 A and 4000 A (special ranges on request). They are in accordance with DIN 43703 and have a class accuracy of 0.5.

A measuring-circuit voltage of 60 mV DC is picked off for rated current I_n .

The measuring-circuit voltage is a linear image of the primary current.

The DIGmat S100 tripping unit monitors the image of the primary current thus supplied and compares it with the tripping characteristic curve set on the device. The parameter settings on the DIGmat S100 apply also for DC feedbacks. Reversing duty is thus possible.

The tripping characteristic curve is determined and described by the following variables:

- Overload protection:
Setting range $I_R = 0.4 \dots 1.0 I_n$
The characteristic curve has an I^2t characteristic
The tripping time t_R is selectable between 2 and 10 s, with t_R defined for $6 \times I_R$



DIGmat S100

- Short-circuit protection:
Setting range $I_i = 1.25 \times I_R$ up to max. $4 \times I_n$
If the set value is exceeded, tripping occurs in less than 50 ms

I_n = Rated current of the circuit breaker
 I_R = current setting value of the adjustable overload release
 t_R = Assigned tripping time of the overload trip
 I_i = Instantaneous tripping current of the adjustable short-circuit release

The components are available only from the company mat – Maschinen- und Anlagentechnik:

mat – Maschinen und Anlagentechnik
Dr. Becker GmbH
Rudolf-Diesel-Straße 22
22941 Bargteheide, Germany
Tel.: +49 (4532) 20-2101
Fax: +49 (4532) 20-2121
E-mail: info@m-a-t.de
Internet: www.m-a-t.de

Configuration**Mutual mechanical circuit breaker interlocks**

The module for mutual mechanical interlocking can be used for two or three 3WL circuit breakers and can be adapted easily to the corresponding versions. The fixed-mounted and withdrawable circuit breaker versions are fully compatible and can therefore be used in a mixed configuration in an installation. This also applies to 3WN6 circuit breakers.

The circuit breakers can be mounted adjacent to each other or one above the other, whereby the distance of the circuit breakers is determined solely by the length of the Bowden cable (lengths: 2 m/3 m/4.5 m). Interlock signals are looped through using the Bowden cables. Interlocking is only effective in the connected position in the case of withdrawable circuit breakers. The mechanical endurance of the Bowden cables is 10000 operating cycles.

To ensure that the interlock functions properly, the following minimum switchgear requirements must be fulfilled:

- Bowden cables must be laid so that they are as straight as possible

- The bending radii of the Bowden cable must be > 500 mm
- The total bending angle across the length of the Bowden cable must not exceed 640°
- If the circuit breakers to be interlocked are arranged vertically, the interlock mechanisms must be aligned
- Circuit breakers to be interlocked must be arranged so that Bowden cables can be optimally installed in compliance with the conditions mentioned in the above points
- The installed Bowden cable must be fixed (with cable ties or the like) before the interlock is adjusted
- Select the width of switchgear cubicle to allow enough freedom of movement for adjusting the interlock!
- Openings and cutout sections in system elements must be designed in such a way that the direction of the Bowden wires is not changed and that the wires are not obstructed when they are routed

Mutual mechanical interlocking of circuit breakers – examples

Mutual interlocking of two circuit breakers	Interlocking of three circuit breakers	Mutual interlocking of three circuit breakers	Interlocking of three circuit breakers, two of them mutual
<p>NSE0_01041</p>	<p>NSE0_01042</p>	<p>NSE0_01043</p>	<p>NSE0_01044</p>
<p>NSE0_01045</p>			

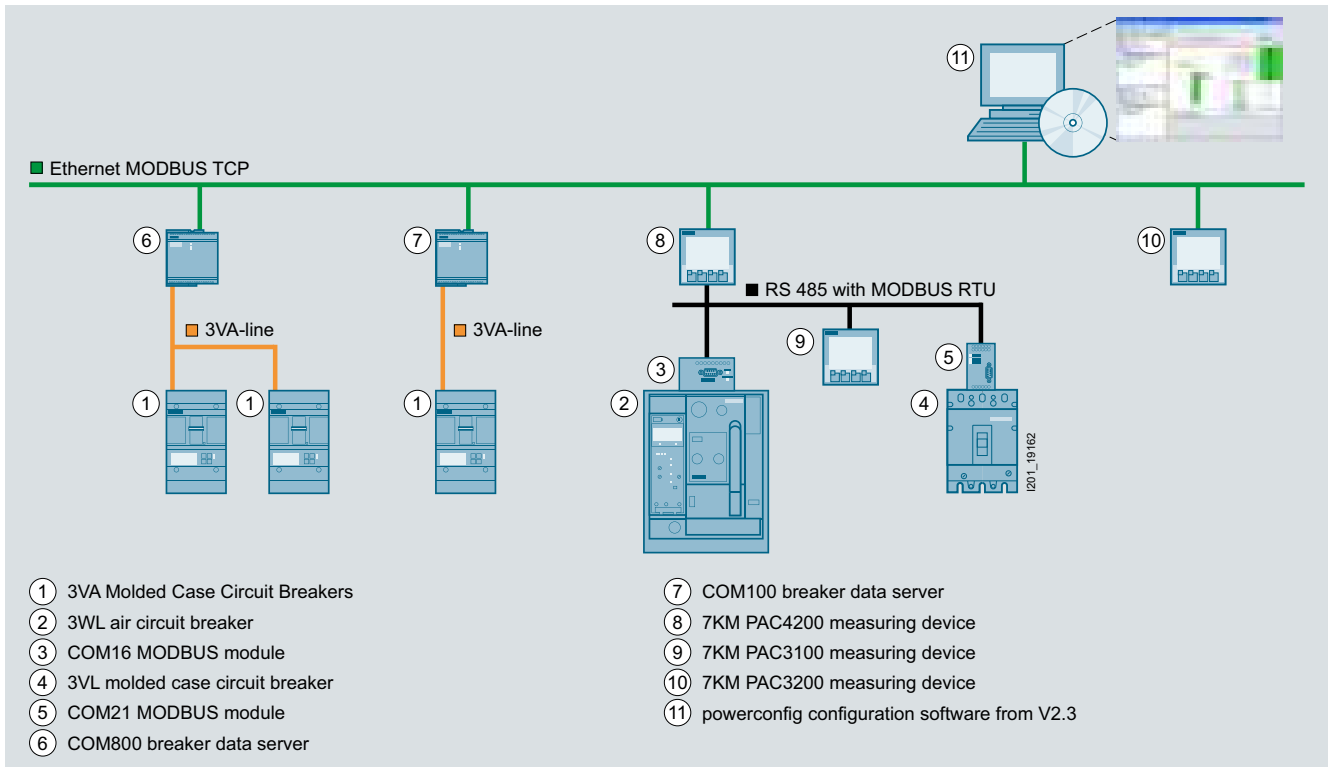

Communication with MODBUS RTU

The requirements for power distribution in terms of communication capability, data transparency, flexibility and integration are constantly increasing. An integrated and modular communication architecture was designed for the 3WL circuit breaker to ensure that it can satisfy these requirements.

The core component of this architecture is the **CubicleBUS**, which links together all of the intelligent components within the 3WL circuit breaker and enables the easy and safe connection of other additional external components to the circuit breaker. The **CubicleBUS** is already incorporated and connected in all complete circuit breakers with ETU45B and ETU76B trip units.

The high modularity of the system allows retrofitting of communication functions (e.g. metering function) at any time. Similarly, the upgrade of a non-communication-capable 3WL circuit breaker (e.g. changeover from ETU25B to ETU45B with **CubicleBUS**) can be carried out easily on site in the plant. All modules connected to the **CubicleBUS** can directly access the existing source data of the circuit breaker, which guarantees the quickest possible access to information and response to events.

Furthermore, additional external modules (including digital inputs and outputs, analog outputs) can be connected to the **CubicleBUS** to provide cost-effective solutions for the automation of additional devices in the switchboard.

3WL Air Circuit Breakers

3WL air circuit breakers/non-automatic air circuit breakers up to 6300 A (AC), IEC

General data

Communication-capable 3WL circuit breakers

Function	Electronic Trip Unit version		Breaker Status Sensor	PROFIBUS communication port	Metering function <i>Plus</i>	Analog output modules	Digital output modules	Digital input modules	ZSI modules	Breaker Data Adapter <i>Plus</i>
	ETU45B	ETU76B								
Functions of the communication-capable 3WL circuit breakers										
Indication of measured values in trip unit (current only)	✓	✓	<input type="checkbox"/>	<input type="checkbox"/>	<input type="checkbox"/>	<input type="checkbox"/>	<input type="checkbox"/>	<input type="checkbox"/>	<input type="checkbox"/>	<input type="checkbox"/>
Indication of measured values in trip unit (<i>U, I, P, S, Q, p.f.</i> , etc.)	✓	✓	<input type="checkbox"/>	<input type="checkbox"/>	✓	<input type="checkbox"/>	<input type="checkbox"/>	<input type="checkbox"/>	<input type="checkbox"/>	<input type="checkbox"/>
Indication of measured values (current only), parameters, diagnostic values etc. on display	--	✓	<input type="checkbox"/>	<input type="checkbox"/>	<input type="checkbox"/>	<input type="checkbox"/>	<input type="checkbox"/>	<input type="checkbox"/>	<input type="checkbox"/>	<input type="checkbox"/>
Indication of measured values (<i>U, I, P, S, Q, p.f.</i> , etc.), parameters, diagnostic values etc. in trip unit	--	✓	<input type="checkbox"/>	<input type="checkbox"/>	✓	<input type="checkbox"/>	<input type="checkbox"/>	<input type="checkbox"/>	<input type="checkbox"/>	<input type="checkbox"/>
Output of measured values (current only) to rotary coil instruments in control cabinet door	✓	✓	<input type="checkbox"/>	<input type="checkbox"/>	<input type="checkbox"/>	✓	<input type="checkbox"/>	<input type="checkbox"/>	<input type="checkbox"/>	<input type="checkbox"/>
Output of measured values (<i>U, I, P, S, Q, p.f.</i> , etc.) to rotary coil instruments in control cabinet door	✓	✓	<input type="checkbox"/>	<input type="checkbox"/>	✓	✓	<input type="checkbox"/>	<input type="checkbox"/>	<input type="checkbox"/>	<input type="checkbox"/>
Output of digital signals (e.g. reason for tripping, alarms, status) through contacts	✓	✓	<input type="checkbox"/>	<input type="checkbox"/>	<input type="checkbox"/>	<input type="checkbox"/>	✓	<input type="checkbox"/>	<input type="checkbox"/>	<input type="checkbox"/>
Automatic changeover between parameter sets A and B	--	✓	<input type="checkbox"/>	<input type="checkbox"/>	<input type="checkbox"/>	<input type="checkbox"/>	<input type="checkbox"/>	✓	<input type="checkbox"/>	<input type="checkbox"/>
Read-in of digital signals and forwarding to PROFIBUS/MODBUS	✓	✓	<input type="checkbox"/>	✓	<input type="checkbox"/>	<input type="checkbox"/>	<input type="checkbox"/>	✓	<input type="checkbox"/>	<input type="checkbox"/>
Transmission of breaker information on HTML basis locally to a PC	✓	✓	✓	<input type="checkbox"/>	<input type="checkbox"/>	<input type="checkbox"/>	<input type="checkbox"/>	<input type="checkbox"/>	<input type="checkbox"/>	✓
Transmission of breaker information on HTML basis through Ethernet	✓	✓	✓	<input type="checkbox"/>	<input type="checkbox"/>	<input type="checkbox"/>	<input type="checkbox"/>	<input type="checkbox"/>	<input type="checkbox"/>	✓
Short-time discrimination for S tripping and G protection	✓	✓	<input type="checkbox"/>	<input type="checkbox"/>	<input type="checkbox"/>	<input type="checkbox"/>	<input type="checkbox"/>	<input type="checkbox"/>	✓	<input type="checkbox"/>
Local display of harmonics analysis and waveform memory	--	✓	<input type="checkbox"/>	<input type="checkbox"/>	✓	<input type="checkbox"/>	<input type="checkbox"/>	<input type="checkbox"/>	<input type="checkbox"/>	<input type="checkbox"/>
Local storage of harmonics analysis and waveform memory and transmission through PROFIBUS	✓	✓	✓	✓	✓	<input type="checkbox"/>	<input type="checkbox"/>	<input type="checkbox"/>	<input type="checkbox"/>	<input type="checkbox"/>
Read-out of protection parameters through PROFIBUS	✓	✓	✓	✓	<input type="checkbox"/>	<input type="checkbox"/>	<input type="checkbox"/>	<input type="checkbox"/>	<input type="checkbox"/>	<input type="checkbox"/>
Read-out and adjustment of protection parameters through PROFIBUS	--	✓	✓	✓	<input type="checkbox"/>	<input type="checkbox"/>	<input type="checkbox"/>	<input type="checkbox"/>	<input type="checkbox"/>	<input type="checkbox"/>

✓ Required

Function can optionally be adopted by several trip units.

Function can optionally be adopted by one of these modules.

Not necessary for this function, optionally combinable

-- Function not available

Data that can be transmitted over the PROFIBUS DP/MODBUS or the Breaker Data Adapter

All 3WL circuit breakers with ETU45B, ETU76B (CubicleBUS integrated)

**Transmittable circuit breaker data**

Order code (Article No. of circuit breaker + "-Z")

Article No.

BSS F01 + "BDAPLUS" Article No.	BDAPLUS	BSS F02/F12	COM15/COM16
--	---------	----------------	-------------

Possible applications**Transmission of circuit breaker data to PROFIBUS DP or MODBUS and integration into higher-level visualization systems possible**

e.g. in PCS7, Power Management Systems, WinCC (incl. add-ons like the text message radio server)

--

✓

Transmission of circuit breaker data and software (i.e. HTML pages with data) to a local output device, or remotely through Ethernet/Intranet/Internet (without the possibility of integration into higher-level visualization systems)

e.g. for monitoring, diagnostics, maintenance and parameterization of individual circuit breakers

✓

--

Utilization of the functionality of all CubicleBUS modules

e.g. configuration of the configurable digital output module, status check of the digital input modules, diagnostics

✓

✓

Transmittable circuit breaker data without integrated metering function**Device identification**

Communication address, Article No., circuit breaker in delivery state, circuit breaker parameters (size, number of poles, rated current module etc.), identification numbers, trip unit type, free text for plant code and comments

✓

✓

Operating states

On/off status message, storage spring, tripped, readiness

✓

✓

Switching position (connected, test and disconnected position, removed)

--¹⁾

✓

for withdrawable circuit breakers, PROFIBUS/MODBUS write protection on/off, free user input

--¹⁾

✓

Control commands

Switch circuit breaker on/off, switch free user output on/off

--¹⁾

✓

Reset tripped signal

✓

✓

Delete event and history memory

--¹⁾

✓

Reset min./max. measured values, reset maintenance information

✓

✓

History

Read out event log, read out trip log

--¹⁾

✓

Maintenance information

Number of tripping operations L, S/I and in total, contact wear

✓

✓

Number of operating cycles under load and in total, number of operating hours

--¹⁾

✓

Event signals

Tripped signals with details of the tripping current

✓

✓

Alarm signals (e.g. overload) with incoming/outgoing information

--¹⁾

✓

All of the named event signals with time stamp

--¹⁾

✓

Parameterization of the protection functions

Read-out of the protection function parameters

✓

✓

Settings for the protection function parameters can be changed by means of communication

✓²⁾✓²⁾

Parameter set switchover possible (set A to set B and back)

✓²⁾✓²⁾**Measured values**

Phase currents, each with min./max. value

✓

✓

Temperature in the circuit breaker with min./max. value

--¹⁾

✓

Temperature in the control cabinet with min./max. value

--¹⁾

✓

All of the named measured values with time stamp

--¹⁾

✓



Metering function Plus

F05

Order code F01+ ... or F02+ ...

Additional transmittable circuit breaker data with integrated metering function**Additional event signals**

Threshold value alarms (e.g. over/underfrequency, over/undervoltage)

✓

Parameterization of the extended protection functions and setpoints (threshold values)

Read-out of the parameters of the extended protection functions

✓

Settings for the extended protection function parameters can be changed

✓

Read-out and adjustment of threshold values

✓

Additional measured values

Voltages, power, energy, power factor, frequency, each with min./max. value

✓

Harmonics analysis

✓

Recording of currents and voltages for configurable events in the waveform memory

✓

¹⁾ Data only available in conjunction with the COM15 module (BUS connection not required).

✓ Available

-- Not available

²⁾ Only possible with ETU76B.

3WL Air Circuit Breakers

3WL air circuit breakers/non-automatic air circuit breakers up to 6300 A (AC), IEC

General data

CubicleBUS modules

Digital output module with rotary coding switch

6 items of binary information concerning the state of the circuit breaker (reasons for tripping and warnings) can be output via this module to external signaling devices (e.g. LED, horn) or used for the selective shutdown of other system components (e.g. frequency converters).

Digital output modules are available in versions with and without a rotary coding switch. On modules with a rotary coding switch it is possible to choose between two signaling blocks each with 6 defined assignments and to set an additional response delay.

All the digital output modules are available as a version with relay outputs (CO contacts, up to 12 A). Up to two modules of this type can be connected to one 3WL circuit breaker.



Digital output module with rotary coding switch

Digital output module, configurable

The configurable output module is available for higher-performance solutions. With this module, random events on the **CubicleBUS** can be switched directly to one of six available outputs or three of these outputs can be assigned with up to six events. In other words, up to six events can be placed on one physical output with OR operation. Either *BDA Plus* or *powerconfig* are used for configuring.

A relay variant is also available here the same as for the output modules with rotary coding switch. Only one module of this type is possible per 3WL circuit breaker.



Digital output module, configurable

Analog output modules

The analog output module can be used to output the following measured values to analog indicators in the control cabinet door:

- $I_{L1}, I_{L2}, I_{L3}, I_N$ or
- $U_{L12}, U_{L23}, U_{L31}, U_{L1N}$ or
- $P_{L1}, P_{L2}, P_{L3}, S_{tot}$ or
- p.f.1, p.f.2, p.f.3, ΔI % or
- $f_{avg}, U_{LLavg}, P_{tot}, p.f. avg$

Four 4-20-mA/0-10-V interfaces are available for this. The measured values to be output are selected with a rotary coding switch. By using the analog output module it is possible to do without additional converters and their conventional installation/wiring in the main current path. Up to two modules of this type can be connected to one 3WL circuit breaker.



Analog output modules

Digital input modules

With the digital input module, up to 6 additional binary signals (24 V DC) in the circuit breaker environment can be connected to the system. It is thus possible for example to send messages concerning the state of a switch disconnector or a control cabinet door to the PROFIBUS DP/MODBUS.

With the digital input module on the **CubicleBUS** it is also possible for the two different protection parameter sets held in the ETU76B E trip unit to be switched over automatically in a few milliseconds. It is thus possible, for example, to automatically change the parameters of a coupling switch should the transformer infeed fail.

One module each of this type can be used for holding the six items of digital information and for automatically switching over the parameters.



Digital input modules

ZSI module (short-time discrimination control)

The use of ZSI modules is recommended when Siemens circuit breakers are arranged in several staggered levels but full discrimination with the smallest possible delay is to be assured nevertheless.

The circuit breakers are interconnected by these modules.

In case of a short-circuit, each affected circuit breaker interrogates the circuit breakers directly downstream whether the short-circuit has also occurred in the next, lower level. The short-circuit is exactly localized as a result, and only the next upstream circuit breaker in the energy flow direction is switched off.



ZSI module (short-time discrimination control)

Technical specifications

Breaking capacity

Size	I			II					III				
Type	3WL11			3WL12					3WL13				
Breaking capacity	N	S	H	N	S	H	C	H	C	C 3-pole	C 4-pole		
Short-circuit breaking capacity													
Rated operational voltage U_e Up to 415 V AC													
I_{cu}	kA	55	66	85	66	80	100	130	100	150	130		
I_{cs}	kA	55	66	85	66	80	100	130	100	150	130		
I_{cm}	kA	121	145	187	145	176	220	286	220	330	286		
Rated operational voltage U_e Up to 500 V AC													
I_{cu}	kA	55	66	85	66	80	100	130	100	150	130		
I_{cs}	kA	55	66	85	66	80	100	130	100	150	130		
I_{cm}	kA	121	145	187	145	176	220	286	220	330	286		
Rated operational voltage U_e Up to 690 V AC													
I_{cu}	kA	42	50	66	50	75	85	100	85	150	130		
I_{cs}	kA	42	50	66	50	75	85	100	85	150	130		
I_{cm}	kA	88	105	145	105	165	187	220	187	330	286		
Rated operational voltage U_e Up to 1000 V/1150 V AC													
I_{cu}	kA	--	--	50 ⁹⁾	--	--	50	--	50	70 ⁴⁾	70 ⁴⁾		
I_{cs}	kA	--	--	50 ⁹⁾	--	--	50	--	50	70 ⁴⁾	70 ⁴⁾		
I_{cm}	kA	--	--	105 ⁹⁾	--	--	105	--	105	154 ⁴⁾	154 ⁴⁾		
Rated short-time withstand current $I_{cw}^{3)}$													
0.5 s	kA	55	66	75	66	80	100	100	100	100	100		
1 s	kA	42	50	66	55	66	80	100	100	100	100		
2 s	kA	29.5	35	46	39	46	65 ^{1)/70²⁾}	70	80	80	80		
3 s	kA	24	29	44	32	44	50 ^{1)/65²⁾}	65	65	65	65		
Short-circuit breaking capacity I_{cc} of the non-automatic air circuit breakers													
Up to 500 V AC	kA	55	66	75	66	80	100	130	100	100	100		
Up to 690 V AC	kA	42	50	66	50	75	85	100	85	100	100		
Up to 1000 V /1150 V AC	kA	--	--	50 ⁹⁾	--	--	50 ⁴⁾	--	50 ⁴⁾	70 ⁴⁾	70 ⁴⁾		

Size	I	II	
Type	3WL11	3WL12	
Breaking capacity	DC	DC	
Short-circuit breaking capacity			
Up to 220 V DC I_{cc}	kA	20	35
Up to 300 V DC I_{cc}	kA	20	30
Up to 600 V DC I_{cc}	kA	20	25
Up to 1000 V DC I_{cc}	kA	20	20
Rated short-time withstand current I_{cw}			
0.5 s	kA	--	--
1 s	kA	20	35 ^{5)/30^{6)/25^{7)/20⁸⁾}}}
2 s	kA	--	--
3 s	kA	--	--

- (N)** Circuit breakers with ECO breaking capacity N
- (S)** Circuit breakers with standard breaking capacity S
- (H)** Circuit breakers with high breaking capacity H
- (C)** Circuit breakers with very high breaking capacity C
- (DC)** Non-automatic air circuit breakers with DC breaking capacity

These breaking capacities are indicated in the corresponding tables by the symbols shown on orange backgrounds.

- 1) Size II with $I_{n \max} \leq 2500$ A.
- 2) Size II with $I_{n \max} = 3200$ A and $I_{n \max} = 4000$ A.
- 3) At a rated voltage of ≥ 690 V, the I_{cw} value of the circuit breaker cannot be greater than the I_{cu} or I_{cs} value at 690 V.
- 4) Rated operational voltage $U_e = 1150$ V.
- 5) At $U_e = 220$ V DC.

Abbreviations* (functions)	English long text	Explanation
L	Long Time Delay	Overload protection
S	Short Time Delay	Short-circuit protection (short-time delayed)
I	Instantaneous	Short-circuit protection (instantaneous)
N	Neutral Protection	Neutral conductor protection
G	Ground Fault	Ground-fault protection

* Designations according to IEC 60947-2, Appendix K.

- 6) At $U_e = 300$ V DC.
- 7) At $U_e = 600$ V DC.
- 8) At $U_e = 1000$ V DC.
- 9) Values also apply to 690 V + 20 % version with Z-option "A16".

3WL Air Circuit Breakers

3WL air circuit breakers/non-automatic air circuit breakers up to 6300 A (AC), IEC

General data

Size	I				II				
	Type	... 3WL11 10	3WL11 12	3WL11 16	3WL11 20	3WL12 08	3WL12 10	3WL12 12	3WL12 16
Rated current I_n at 40 °C, at 50/60 Hz									
Main conductor	A	... 1000	1250	1600	2000	800	1000	1250	1600
N conductor (only on 4-pole versions)	A	... 1000	1250	1600	2000	800	1000	1250	1600
Rated operational voltage U_e at 50/60 Hz (1000 V version, see Catalog LV 10, "Options")									
	V AC	690/1000	690/1000	690/1000	690/1000	690/1000	690/1000	690/1000	690/1000
Rated insulation voltage U_i									
	V AC	1000	1000	1000	1000	1000	1000	1000	1000
Rated impulse withstand voltage U_{imp}									
• Main conducting paths	kV	12	12	12	12	12	12	12	12
• Auxiliary circuits	kV	4	4	4	4	4	4	4	4
• Control circuits	kV	2.5	2.5	2.5	2.5	2.5	2.5	2.5	2.5
Isolating function acc. to EN 60 947-2									
		Yes	Yes	Yes	Yes	Yes	Yes	Yes	Yes
Utilization category									
		B							
Permissible ambient temperature									
• During operation (in operation with LCD max. 55 °C) ¹⁾	°C	-25/+70	-25/+70	-25/+70	-25/+70	-25/+70	-25/+70	-25/+70	-25/+70
• Storage	°C	-40/+70	-40/+70	-40/+70	-40/+70	-40/+70	-40/+70	-40/+70	-40/+70
Permissible load for withdrawable versions									
• Up to 55 °C (Cu bare)	A	1000	1250	1600	2000	800	1000	1250	1600
• Up to 60 °C (Cu bare) ²⁾	A	1000	1250	1600	1930	800	1000	1250	1600
At rear horizontal main connections (Cu black painted) ²⁾	A	1000	1210	1490 ³⁾	1780	800	1000	1250	1600
Rated rotor operational voltage U_{er}									
	V	2000	2000	2000	2000	2000	2000	2000	2000
Power loss at I_n									
With 3-phase symmetrical load									
• Fixed-mounted circuit breakers	W	100	105	150	240	40	45	80	85
• Withdrawable circuit breakers	W	195	205	350	440	85	95	165	175
Switching times									
• Make time	ms	35	35	35	35	35	35	35	35
• Opening time	ms	38	38	38	38	34	34	34	34
• Electrical make time (through closing solenoid) ⁴⁾	ms	80	80	80	80	100	100	100	100
• Electrical opening time (through shunt release)	ms	73	73	73	73	73	73	73	73
• Electrical opening time (instant. undervoltage release)	ms	73	73	73	73	73	73	73	73
• Opening time due to ETU, instantaneous short-circuit release	ms	50	50	50	50	50	50	50	50
Service life: Breaking capacity N and S, 3-/4-pole									
• Mechanical (without maintenance)	Operating cycles	10 000	10 000	10 000	10 000	10 000	10 000	10 000	10 000
• Mechanical (with maintenance) ⁵⁾	Operating cycles	20 000	20 000	20 000	15 000	15 000	15 000	15 000	15 000
• Electrical (without maintenance)	Operating cycles	10 000	10 000	10 000	7 500	7 500	7 500	7 500	7 500
• 1000 V version, electrical (without maintenance)	Operating cycles	--	--	--	1 000	1 000	1 000	1 000	1 000
• 1150 V version, electrical (without maintenance)	Operating cycles	--	--	--	--	500	500	500	500
• Electrical (with maintenance) ⁵⁾	Operating cycles	20 000	20 000	20 000	15 000	15 000	15 000	15 000	15 000
Service life: Breaking capacity H, 3-pole									
• Mechanical (without maintenance)	Operating cycles	10 000	10 000	10 000	10 000	10 000	10 000	10 000	10 000
• Mechanical (with maintenance) ⁵⁾	Operating cycles	15 000	15 000	15 000	15 000	15 000	15 000	15 000	15 000
• Electrical (without maintenance)	Operating cycles	7 500	7 500	7 500	7 500	7 500	7 500	7 500	7 500
• 1000 V version, electrical (without maintenance)	Operating cycles	1 000	1 000	1 000	1 000	1 000	1 000	1 000	1 000
• 1150 V version, electrical (without maintenance)	Operating cycles	--	--	--	--	500	500	500	500
• Electrical (with maintenance) ⁵⁾⁶⁾	Operating cycles	15 000	15 000	15 000	15 000	15 000	15 000	15 000	15 000
Service life: Breaking capacity H, 4-pole									
• Mechanical (without maintenance)	Operating cycles	10 000	10 000	10 000	10 000	10 000	10 000	10 000	10 000
• Mechanical (with maintenance) ⁵⁾	Operating cycles	15 000	15 000	15 000	15 000	15 000	15 000	15 000	15 000
• Electrical (without maintenance)	Operating cycles	7 500	7 500	7 500	7 500	7 500	7 500	7 500	7 500
• 1000 V version, electrical (without maintenance)	Operating cycles	1 000	1 000	1 000	1 000	1 000	1 000	1 000	1 000
• 1150 V version, electrical (without maintenance)	Operating cycles	--	--	--	--	500	500	500	500
• Electrical (with maintenance) ⁵⁾⁶⁾	Operating cycles	10 000	10 000	10 000	10 000	15 000	15 000	15 000	15 000
Service life: Breaking capacity C									
• Mechanical (without maintenance)	Operating cycles	--	--	--	--	5 000	5 000	5 000	5 000
• Mechanical (with maintenance) ⁵⁾	Operating cycles	--	--	--	--	10 000	10 000	10 000	10 000
• Electrical (without maintenance)	Operating cycles	--	--	--	--	5 000	5 000	5 000	5 000
• Electrical (with maintenance) ⁵⁾	Operating cycles	--	--	--	--	10 000	10 000	10 000	10 000
Switching frequency⁷⁾									
• 690 V version	1/h	60 ⁸⁾	60 ⁸⁾	60 ⁸⁾	60	60 ⁸⁾	60 ⁸⁾	60 ⁸⁾	60 ⁸⁾
• 1000 V version	1/h	--	--	--	20	20	20	20	20
• 1150 V version	1/h	--	--	--	--	20	20	20	20
Minimum interval between tripping operation by electronic trip unit and next making operation of the circuit breaker (only with autom. mechanical resetting of the lockout device). Minimum interval between On-Off or Off-On switching operations.									
	ms	80	80	80	80	80	80	80	80

1) Use of trip units from -20 °C.

2) ETU76B with graphics display can be used up to max. 55 °C.

3) At breaking capacity H: 1600 A to 70 °C.

4) Make-time through closing solenoid for synchronization purposes (short-time excited) 50 ms.

5) Maintenance means: replace main contact elements and arc chutes (see Operating Manual).

6) Replacement of the main contact elements of circuit breakers size I with breaking capacity H is only possible at the factory.

7) Minimum interval time between 2 tripping operations.

8) 3-pole switching with breaking capacity N and S: 45/h.

3WL Air Circuit Breakers

3WL air circuit breakers/non-automatic air circuit breakers up to 6300 A (AC), IEC

General data

Size	I				II					
Type	... 3WL11 10	3WL11 12	3WL11 16	3WL11 20	3WL12 08	3WL12 10	3WL12 12	3WL12 16		
Mounting position										
Degree of protection	IP20 without cabinet door, IP41 with door sealing frame, IP55 with cover									
Main conductor minimum cross-sections	<ul style="list-style-type: none"> Copper bars, bare Copper bars, painted black 	Unit(s) mm ²	1 x 60 x 10	2 x 40 x 10	2 x 50 x 10	3 x 50 x 10	1 x 50 x 10	1 x 60 x 10	2 x 40 x 10	2 x 50 x 10
Auxiliary conductors (Cu)	Standard connection = strain-relief clamp	Unit(s) mm ²	2 x 0.5 mm ² (AWG 20) ... 2 x 1.5 mm ² (AWG 16); 1 x 2.5 mm ² (AWG 14)							
Max. number	• Without end sleeve		1 x 0.5 mm ² (AWG 20) ... 1 x 1.5 mm ² (AWG 16)							
Auxiliary conductors x cross-section (solid/stranded)	• With end sleeve acc. to DIN 46228 Part 2		2 x 0.5 mm ² (AWG 20) ... 2 x 1.5 mm ² (AWG 16)							
	• With twin end sleeve		2 x 0.5 mm ² (AWG 20) ... 2 x 1.5 mm ² (AWG 16)							
	Optional connection = tension spring		2 x 0.5 mm ² (AWG 20) ... 2 x 2.5 mm ² (AWG 14)							
	• Without end sleeve		2 x 0.5 mm ² (AWG 20) ... 2 x 1.5 mm ² (AWG 16)							
	• With end sleeve acc. to DIN 46228 Part 2		2 x 0.5 mm ² (AWG 20) ... 2 x 1.5 mm ² (AWG 16)							
Position signaling switches	Tension spring terminals		1 x 0.5 mm ² (AWG 20) ... 1 x 2.5 mm ² (AWG 14)							
Weights	3-pole		kg	43	43	43	43	56	56	56
		• Fixed-mounted circuit breakers	kg	45	45	45	45	60	60	60
		• Withdrawable circuit breakers	kg	25	25	25	25	31	31	31
	4-pole	• Guide frames	kg	50	50	50	50	67	67	67
		• Fixed-mounted circuit breakers	kg	54	54	54	54	72	72	72
		• Withdrawable circuit breakers	kg	30	30	30	30	37	37	37
		• Guide frames	kg	30	30	30	30	37	37	37

3WL Air Circuit Breakers

3WL air circuit breakers/non-automatic air circuit breakers up to 6300 A (AC), IEC

General data

Size	II				III			
Type	3WL12 20	3WL12 25	3WL12 32	3WL12 40	3WL13 40	3WL13 50	3WL13 63	
Rated current I_n at 40 °C, at 50/60 Hz								
Main conductor	A 2000	2500	3200	4000	4000	5000	6300	
N conductor (only on 4-pole versions)	A 2000	2500	3200	4000	4000	5000	6300	
Rated operational voltage U_e at 50/60 Hz (1000 V version, see Catalog LV 10, "Options")	V AC 690	
	690/1000	690/1000	690/1000	690/1000	690/1000	690/1000	690/1000	
Rated insulation voltage U_i	V AC 1000	1000	1000	1000	1000	1000	1000	
Rated impulse withstand voltage U_{imp}								
• Main conducting paths	kV 12	12	12	12	12	12	12	
• Auxiliary circuits	kV 4	4	4	4	4	4	4	
• Control circuits	kV 2.5	2.5	2.5	2.5	2.5	2.5	2.5	
Isolating function acc. to EN 60947-2	Yes	Yes	Yes	Yes	Yes	Yes	Yes	
Utilization category	B							
Permissible ambient temperature								
• During operation (in operation with LCD max. 55 °C) ¹⁾	°C -25/+70	-25/+70	-25/+70	-25/+70	-25/+70	-25/+70	-25/+70	
• Storage	°C -40/+70	-40/+70	-40/+70	-40/+70	-40/+70	-40/+70	-40/+70	
Permissible load for withdrawable versions²⁾								
• Up to 55 °C (Cu bare)	A 2000	2500	3200	3950 ³⁾	4000	5000	5920	
• Up to 60 °C (Cu bare) ⁴⁾	A 2000	2500	3020	3810	4000	5000	5810	
• Up to 70 °C (Cu black painted) ⁴⁾	A 2000	2280	2870	3600	4000	5000	5500	
Rated rotor operational voltage U_{er}	V 2000	2000	2000	2000	2000	2000	2000	
Power loss at I_n								
With 3-phase symmetrical load								
• Fixed-mounted circuit breakers	W 180	270	410	750	520	630	900	
• Withdrawable circuit breakers	W 320	520	710	925	810	1050	1600	
Switching times								
• Make time	ms 35	35	35	35	35	35	35	
• Opening time	ms 34	34	34	34	34	34	34	
• Electrical make time (through closing solenoid) ⁵⁾	ms 100	100	100	100	100	100	100	
• Electrical opening time (through shunt release)	ms 73	73	73	73	73	73	73	
• Electrical opening time (instantaneous undervoltage release)	ms 73	73	73	73	73	73	73	
• Opening time due to ETU, instantaneous short-circuit release	ms 50	50	50	50	50	50	50	
Service life: Breaking capacity N, S and H								
• Mechanical (without maintenance)	Operating cycles 10000	10000	10000	10000	5000	5000	5000	
• Mechanical (with maintenance) ⁶⁾	Operating cycles 15000	15000	15000	15000	10000	10000	10000	
• Electrical (without maintenance) up to 690 V	Operating cycles 7500	7500	4000	2000	2000	2000	2000	
• 1000 V version, electrical (without maintenance)	Operating cycles 1000	1000	1000	1000	1000	1000	1000	
• 1150 V version, electrical ⁷⁾ (without maintenance)	Operating cycles 500	500	500	500	500	500	500	
• Electrical (with maintenance) ⁶⁾	Operating cycles 15000	15000	15000	15000	10000	10000	10000	
Service life: Breaking capacity C								
• Mechanical (without maintenance)	Operating cycles 5000	5000	5000	--	5000	5000	5000	
• Mechanical (with maintenance) ⁶⁾	Operating cycles 10000	10000	10000	--	10000	10000	10000	
• Electrical (without maintenance) up to 690 V	Operating cycles 5000	5000	4000	--	1000	1000	1000	
• Electrical (without maintenance) up to 1150 V	Operating cycles --	--	--	--	500	500	500	
• Electrical (with maintenance) ⁶⁾	Operating cycles 10000	10000	8000	--	--	--	--	
Switching frequency⁸⁾								
• 690 V version	1/h 60 ⁹⁾	60 ⁹⁾	60 ⁹⁾	60 ⁹⁾	60	60	60	
• 1000 V version	1/h 20	20	20	20	20	20	20	
• 1150 V version ⁷⁾	1/h 20	20	20	20	20	20	20	
Minimum interval between tripping operation by electronic trip unit and next making operation of the circuit breaker (only with autom. mechanical resetting of the lockout device)	ms 80	80	80	80	80	80	80	
Minimum interval between On-Off or Off-On switching operations.								

¹⁾ Use of trip units from -20 °C.

²⁾ 4000 A, size II in fixed-mounted version, 3-pole.

³⁾ Derating factors for fixed mounting of 3WL12 40.

⁴⁾ ETU76B with graphics display can be used up to max. 55 °C.

⁵⁾ Make-time through closing solenoid for synchronization purposes (short-time excited) 50 ms.

⁶⁾ Maintenance means: replace main contact elements and arc chutes (see Operating Manual).

⁷⁾ Size II with order code "A15" and size III: data for very high breaking capacity.

⁸⁾ Minimum interval time between 2 tripping operations.

⁹⁾ 3-pole switching with breaking capacity N and S: 45/h.

3WL Air Circuit Breakers

3WL air circuit breakers/non-automatic air circuit breakers up to 6300 A (AC), IEC

General data

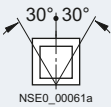
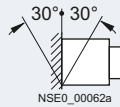
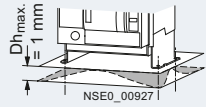
Size	II				III					
Type	3WL12 20	3WL12 25	3WL12 32	3WL12 40	3WL13 40	3WL13 50	3WL13 63			
Mounting position	 NSE0_00061a		and/or	 NSE0_00062a		 NSE0_00927 I				
Degree of protection	IP20 without cabinet door, IP41 with door sealing frame, IP55 with cover									
Main conductor minimum cross-sections	<ul style="list-style-type: none"> Copper bars, bare 	<ul style="list-style-type: none"> Copper bars, painted black 								
	Unit(s)	3 x	2 x	3 x	4 x	4 x	6 x	6 x		
	mm ²	50 x 10	100 x 10	100 x 10	120 x 10	100 x 10	100 x 10	120 x 10		
	Unit(s)	3 x	2 x	3 x	4 x	4 x	6 x	6 x		
	mm ²	50 x 10	100 x 10	100 x 10	100 x 10 ¹⁾	100 x 10	100 x 10	120 x 10		
Auxiliary conductors (Cu)	Standard connection = strain-relief clamp									
Max. number of auxiliary conductors x cross-section (solid/stranded)	<ul style="list-style-type: none"> Without end sleeve With end sleeve acc. to DIN 46228 Part 2 With twin end sleeve 									
	2 x 0.5 mm ² (AWG 20) ... 2 x 1.5 mm ² (AWG 16); 1 x 2.5 mm ² (AWG 14)									
	1 x 0.5 mm ² (AWG 20) ... 1 x 1.5 mm ² (AWG 16)									
	2 x 0.5 mm ² (AWG 20) ... 2 x 1.5 mm ² (AWG 16)									
	Optional connection = tension spring									
	<ul style="list-style-type: none"> Without end sleeve With end sleeve acc. to DIN 46228 Part 2 									
	2 x 0.5 mm ² (AWG 20) ... 2 x 2.5 mm ² (AWG 14)									
	2 x 0.5 mm ² (AWG 20) ... 2 x 1.5 mm ² (AWG 16)									
Position signaling switches	Tension spring terminals									
	1 x 0.5 mm ² (AWG 20) ... 1 x 2.5 mm ² (AWG 14)									
Weights	3-pole	<ul style="list-style-type: none"> Fixed-mounted circuit breakers Withdrawable circuit breakers Guide frames 	kg	56	59	64	85	82	82	90
			kg	60	63	68	121	88	88	96
			kg	31	39	45	52	60	60	70
	4-pole	<ul style="list-style-type: none"> Fixed-mounted circuit breakers Withdrawable circuit breakers Guide frames 	kg	67	71	77	103	99	99	108
			kg	72	76	82	146	106	106	108
			kg	37	47	54	62	84	84	119

¹⁾ Minimum main conductor cross-sections for 4-pole withdrawable circuit breakers: 4 x 120 x 10 mm.

3WL Air Circuit Breakers

3WL air circuit breakers/non-automatic air circuit breakers up to 6300 A (AC), IEC

General data

Size	I to III		
Type	3WL1		
Manual operating mechanism with mechanical closing			
Closing/charging the stored-energy spring mechanism	Max. force required to operate the hand lever Required number of strokes on the hand lever	N	≤ 230 9
Manual operating mechanism with mechanical and electrical closing			
Charging the stored-energy spring mechanism			
Closing solenoid (CC)	<ul style="list-style-type: none"> Primary operating range Extended operating range for battery operation 	At 24 V DC, 48 V DC 60 V DC, 110 V DC 220 V DC	0.85 ... 1.1 × U_s 0.7 ... 1.26 × U_s
	Rated control supply voltage U_s	50/60 Hz AC DC	V 110 ... 127; 208 ... 240 V 24; 30; 48; 60; 110 ... 125; 220 ... 250
	Power consumption	AC/DC	VA/ W 15/15
	Min. command duration at U_s for the closing solenoid		ms 60
	Short-circuit protection Smallest permissible DIAZED fuse (operational class gL)/ Miniature circuit breaker with C characteristic		1 A TDz (slow)/1 A
Manual/motorized operating mechanism with mechanical and electrical closing			
Manual operating mechanism	For data, see above.		
Motor	<ul style="list-style-type: none"> Primary operating range Extended operating range for battery operation 	At 24 V DC, 48 V DC 60 V DC, 110 V DC 220 V DC	0.85 ... 1.1 × U_s 0.7 ... 1.26 × U_s
	Power consumption of motor	AC/DC	VA/ W 135/135
	Time required to charge the stored-energy mechanism at 1 × U_s		s ≤ 10
Closing solenoid For motor and closing solenoid	<ul style="list-style-type: none"> Short-circuit protection Smallest permissible DIAZED fuse (operational class gL)/ Miniature circuit breaker with C characteristic; Motor and closing solenoid for the same rated control supply voltages Smallest permissible DIAZED fuse (operational class gL)/ Miniature circuit breaker with C characteristic (for different rated control supply voltages) 	At $U_s = 24 ... 30$ V At $U_s = 48 ... 60$ V At $U_s = 110 ... 125$ V DC/ 110 ... 127 V AC At $U_s = 220 ... 250$ V DC/ 208 ... 240 V AC	6 A 6 A 2 A 2 A
Signals of the Electronic Trip Unit			
Measuring accuracy of the Electronic Trip Unit	Protection functions acc. to EN 60947 Current indications ≤ 10 % Metering function for base quantities ≤ 1 %; metering function for derived quantities ≤ 4 %		
Auxiliary releases			
Undervoltage releases UVR (F3) and UVR-t_d (F4)	<ul style="list-style-type: none"> Response values 	Pickup Dropout	≥ 0.85 × U_s (circuit breaker can be closed) 0.35 ... 0.7 × U_s (circuit breaker is tripped)
	<ul style="list-style-type: none"> Primary operating range Extended operating range for battery operation 	At 24 V DC, 30 V DC, 48 V DC, 110 V DC, 220 V DC	0.85 ... 1.1 0.85 ... 1.26
	Rated control supply voltage U_s	Instantaneous 50/60 Hz AC DC	V 110 ... 127/208 ... 240/380 ... 415 V 24/30/48/60/110 ... 125/220 ... 250 ¹⁾
		Delayed 50/60 Hz AC DC	V 110 ... 127; 208 ... 240; 380 ... 415 V 48; 110 ... 125; 220 ... 250
	Power consumption (pickup/uninterrupted duty)	AC DC	VA 20/5 W 20/5
	Opening time of circuit breaker at $U_s = 0$		ms 200
	- Version UVR (F3)		
	Instantaneous		ms 80
	With delay		ms 200
	- Version UVR- t_d (F8)		
	With delay, $t_d = 0.2$ to 3.2 s		s 0.2 ... 3.2
	Reset through additional NC contact – direct tripping		ms ≤ 100
	Short-circuit protection Smallest permissible DIAZED fuse (operational class gL)/ Miniature circuit breaker with C characteristic		1 A TDz (slow)/1 A

¹⁾ 24 V and 30 V only with undervoltage release UVR (F3).

Size					I to III		
Type					3WL1		
Auxiliary releases							
Shunt releases (ST) (F1, F2)	<ul style="list-style-type: none"> For continuous command (100 % OP), locks out on momentary-contact commands 	- Response value	Pickup		$> 0.7 \times U_s$ (circuit breaker is tripped)		
		- Primary operating range			$0.85 \dots 1.1 \times U_s$		
		- Extended operating range for battery operation	At 24 V DC, 48 V DC 60 V DC, 110 V DC 220 V DC			$0.7 \dots 1.26 \times U_s$	
		- Rated control supply voltage U_s	50/60 Hz AC DC	V		110 ... 127; 208 ... 240 24; 30; 48; 60; 110 ... 125; 220 ... 250	
		- Power consumption	AC/DC	VA/W		15/15	
		- Min. command duration at U_s		ms		60	
		- Opening time of circuit breaker at $U_s = 100\%$	At AC/DC	ms		80	
		- Short-circuit protection Smallest permissible DIAZED fuse (operational class gL)/ Miniature circuit breaker with C characteristic				1 A TDz (slow)/1 A	
		5 % OP	- Response value	Pickup		$> 0.7 \times U_s$ (circuit breaker is tripped)	
			- Primary operating range			$0.85 \dots 1.1 \times U_s$	
			- Extended operating range for battery operation	At 24 V DC, 48 V DC 60 V DC, 110 V DC 220 V DC			$0.7 \dots 1.26 \times U_s$
			- Rated control supply voltage U_s	50/60 Hz AC DC	V		110 ... 127; 208 ... 240 24; 48; 110 ... 125; 220 ... 250
			- Power consumption	AC/DC	VA/W		15/15
			- Min. command duration at U_s		ms		25
	- Opening time of circuit breaker at $U_s = 100\%$	At AC/DC	ms		50		
	- Short-circuit protection Smallest permissible DIAZED fuse (operational class gL)/ Miniature circuit breaker with C characteristic				1 A TDz (slow)/1 A		
<ul style="list-style-type: none"> With stored energy feature consisting of shunt release and capacitor storage device 	- Rated control supply voltage U_s	50/60 Hz AC DC	V		110; 230 110; 220		
	- Primary operating range				$0.85 \dots 1.1 \times U_s$		
	- Power consumption	AC/DC	VA/W		1/1		
	- Storage time at U_s / recharging time at U_s					Max. 5 min/min. 5 s	
	- Opening time of circuit breaker, short-circuit protection					As with "for continuous command"	
Remote reset solenoid for mechanical tripped indicator (F7)							
Remote reset solenoid for mechanical tripped indicator (F7)	- Primary operating range				$0.85 \dots 1.1 \times U_s$		
	- Extended operating range for battery operation	At 24 V DC, 48 V DC 110 V DC 220 V DC			$0.7 \dots 1.26 \times U_s$		
	- Power consumption	AC/DC	VA/W		50/50		
	- Min. command duration at U_s for the remote reset solenoid		ms		60		
	- Short-circuit protection Smallest permissible DIAZED fuse (operational class gL)/ Miniature circuit breaker with C characteristic					2 A TDz (slow)/1 A at 24 V DC and 48 V DC, 1 A TDz (slow)/1 A at 110 V and 208 ... 250 V	
Contact position-driven auxiliary switches (S1, S2, S3, S4, S7, S8)							
Rated insulation voltage U_i			V		500		
			AC/DC				
Rated operational voltage U_e			V		500		
			AC/DC				
Rated impulse withstand voltage U_{imp}			kV		4		
Breaking capacity	<ul style="list-style-type: none"> Alternating current 50/60 Hz 	- Rated operational voltage U_e	V	24 ... 230	380/400	500	
		- Rated operational current I_e /AC-12	A	10	10	10	
		- Rated operational current I_e /AC-15	A	4	3	2	
		- Rated operational voltage U_e	V	24	48	110	220
		- Rated operational current I_e /DC-12	A	10	8	3.5	1
	<ul style="list-style-type: none"> Direct current 	- Rated operational current I_e /DC-13	A	8	4	1.2	0.4
		- Rated operational voltage U_e	V	24	48	110	220
		- Rated operational current I_e /DC-12	A	10	8	3.5	1
		- Rated operational current I_e /DC-13	A	8	4	1.2	0.4
		- Rated operational voltage U_e	V	24	48	110	220
Short-circuit protection	<ul style="list-style-type: none"> Largest permissible DIAZED fuse (operational class gL) Largest permissible miniature circuit breaker with C characteristic 					10 A TDz, 10 A Dz 10 A	

3WL Air Circuit Breakers

3WL air circuit breakers/non-automatic air circuit breakers up to 6300 A (AC), IEC

General data

Size	I to III			
Type	3WL1			
Ready-to-close signaling switch (S20) (acc. to DIN VDE 0630)				
Breaking capacity	• Alternating current	- Rated operational voltage U_e	V	250
		- Rated operational current I_e	A	8
• Direct current	- Rated operational voltage U_e	V	125	250
	- Rated operational current I_e	A	0.4	0.2
Short-circuit protection	Largest permissible DIAZED fuse (operational class gL)			2 A Dz (quick)
Trip alarm switch (S24) and signal switch for auxiliary releases (S22, S23) (acc. to DIN VDE 0630)				
Breaking capacity	• Alternating current	- Rated operational voltage U_e	V	250
		- Rated operational current $I_e/AC-12$	A	8
• Direct current	- Rated operational voltage U_e	V	24	125
	- Rated operational current $I_e/DC-12$	A	6	0.4
Short-circuit protection	Largest permissible DIAZED fuse (operational class gL)			6 A Dz (quick)
Trip alarm switch	Signal duration after tripping			Until manual or electrical remote reset (option)
Position signaling switch on guide frame				
Type of contact	• Message:	- "Circuit breaker in connected position"	3 CO	1 CO
		- "Circuit breaker in test position"	2 CO	1 CO
		- "Circuit breaker in disconnected position"	1 CO	1 CO
Rated insulation voltage U_i	50/60 Hz AC	V	440	
	DC	V	250	
Rated operational voltage U_e		V	250	
Rated impulse withstand voltage U_{imp}		kV	4	
Breaking capacity	• Rated operational current I_e	- $I_e/AC-12$	24 V 10 A, 110/127 V 10 A, 220/240 V 10 A, 320/440 V 10 A	
		- $I_e/AC-15$	220/240 V 4 A, 320/440 V 3 A,	
		- $I_e/DC-12$	24 V 10 A, 48 V 2.5 A, 220/240 V 0.2 A,	
		- $I_e/DC-13$	24 V 3.0 A, 220/240 V 0.1 A	
		- A 300 (AC)	120 V 6 A, 240 V 3 A	
		- R 300 (DC)	125 V 0.22 A, 250 V 0.11 A	
Short-circuit protection	• Largest permissible DIAZED fuse (operational class gL)			8 A TDz (slow)
	• Largest permissible miniature circuit breaker with C characteristic			8 A TDz (slow)

3WL Air Circuit Breakers

3WL air circuit breakers/non-automatic air circuit breakers up to 6300 A (AC), IEC

General data

Protection functions Parameterization by	ETU45B D & S	ETU76B M/K	
Function overview of the electronic trip system			
Overload protection	✓	✓	
Function can be switched on/off	--	✓	
Setting range $I_R = I_n \times \dots$	0.4-0.45-0.5-0.55-0.6- 0.65-0.7-0.8-0.9-1	0.4 ... 1	
Switchable overload protection (I^2t - or I^1t -dependent function)	✓	✓	
Setting range for time-lag class t_R at I^2t	2-3-5-5.5-8-10-14-17-21-25-30 s	2 ... 30 s	
Setting range for time-lag class t_R at I^1t	1-2-3-4-5 s	1 ... 5 s	
Thermal image can be switched on/off	✓	✓	
Phase failure sensitivity	At $t_{sd} = 20$ ms (M)	✓ (on/off)	
N-conductor protection	✓	✓	
Function can be switched on/off	✓	✓	
N conductor setting range $I_N = I_n \times \dots$	0.5 ... 1	0.2 ... 2	
Short-time delayed short-circuit protection	✓	✓	
Function can be switched on/off	✓	✓	
Setting range $I_{sd} = I_n \times \dots$	1.25-1.5-2-2.5-3-4-6-8-10-12	$1.25 \times I_n \dots 0.8 \times I_{cw}$	
Setting range for delay time t_{sd}	M-100-200-300-400 ms	M-80 ... 4000 ms	
Switchable short-time delayed short-circuit protection (I^2t -dependent function)	✓	✓	
Setting range for delay time t_{sd} at I^2t	100-200-300-400 ms	100 ... 400 ms	
ZSI function	By CubicleBUS module	By CubicleBUS module	
Instantaneous short-circuit protection	✓	✓	
Function can be switched on/off	✓	✓	
Setting range $I_1 = I_n \times \dots$	1.5-2-2.3-4-6-8-10-12-0.8 $\times I_{cs}$	$1.5 \times I_n \dots 0.8 \times I_{cs}$	
Ground-fault protection	<input type="checkbox"/> Module can be retrofitted	<input type="checkbox"/> Module can be retrofitted	
Tripping and alarm functions	✓	✓	
Tripping function can be switched on/off	✓	✓	
Alarm function can be switched on/off	--	✓	
Detection of the ground-fault current through summation current formation with int. or ext. N conductor transf.	✓	✓	
Detection of ground-fault current through external current transformer	✓	✓	
Setting range of the operating current I_g for tripping	A-B-C-D-E	A ... E	
Setting range of the operating current I_g for alarm	A-B-C-D-E	A ... E	
Setting range of the delay time t_g	100-200-300-400-500 ms	100 ... 500 ms	
Switchable ground-fault protection characteristic curve (I^2t -dependent function)	✓	✓	
Setting range for delay time t_g at I^2t	100-200-300-400-500 ms	100 ... 500 ms	
ZSI-G function	By CubicleBUS module	By CubicleBUS module	
Parameter set changeover			
Switchable between parameter set A and B	--	✓	
LCD			
Alphanumeric LCD (4-line)	<input type="checkbox"/>	--	
Graphical LCD (24 V, external power supply required)	--	✓	
Communication			
CubicleBUS integrated	✓	✓	
Communications capability via PROFIBUS DP	✓	✓	
Metering function			
Metering function capability with metering function <i>Plus</i>	✓	✓	
LED display			
Electronic trip unit active	✓	✓	
Alarm	✓	✓	
ETU fault	✓	✓	
L tripping operation	✓	✓	
S tripping operation	✓	✓	
I tripping operation	✓	✓	
N tripping operation	✓	✓	
G tripping operation	✓ (only with ground-fault prot. mod.)	✓ (only with ground-fault prot. mod.)	
G alarm	✓ (only with ground-fault prot. mod.)	✓ (only with ground-fault prot. mod.)	
Tripping operation as a result of ext. protect. functions	✓	✓	
Communication	✓	✓	
Signals from signaling switches with external CubicleBUS modules (relays)			
Overload warning	✓	✓	
Load shedding, load absorbing	✓	✓	
Leading signal overload trip 200 ms	✓	✓	
Temperature alarm	✓	✓	
Phase unbalance	✓	✓	
Instantaneous short-circuit trip	✓	✓	
Short-time delayed short-circuit trip	✓	✓	
Overload trip	✓	✓	
Neutral conductor trip	✓	✓	
Ground-fault protection trip	✓ (only with ground-fault prot. mod.)	✓ (only with ground-fault prot. mod.)	
Ground-fault alarm	✓ (only with ground-fault prot. mod.)	✓ (only with ground-fault prot. mod.)	
Auxiliary relay	✓	✓	
ETU fault	✓	✓	
Setting range of the operating current I_g			
	Size I and size II	Size III	
A	100 A	400 A	
B	300 A	600 A	
C	600 A	800 A	
D	900 A	1000 A	
E	1200 A	1200 A	
Increment size when settings are made for the ETU76B using the menu			
From ... to	Increment size	From ... to	Increment size
0 ... 1	0.1	1000 ... 1600	50
1 ... 100	1	1600 ... 10000	100
100 ... 500	5	10000 ... max.	1000
500 ... 1000	10		

Legend, see page 35.

Characteristic curves²⁾

Every electronic trip unit type and every setting has its own characteristic curve. Only a selection is shown in the following. The characteristic curves each show the largest and smallest setting range of 3WL circuit breakers with 1000 A rated current at 500 V rated voltage with various trip units. In order to obtain a complete tripping characteristic, the relevant parts of the characteristics have to be combined. The characteristic curves show the behavior of the electronic trip unit when it is activated by a current that is already flowing before the tripping operation. If the overcurrent tripping occurs immediately after closing and the electronic trip unit is therefore not yet activated, the opening time is extended, depending on the level of the overcurrent by up to 15 ms. To determine the break-times of the circuit breakers, approximately 15 ms must be added to the opening times shown for the arcing time.

Refer to the following legend for tolerances.

The characteristic curves shown apply to ambient temperatures at the circuit breaker between -5 and +55°C. The trip unit can be operated at ambient temperatures of -20 to +70°C. An extended tolerance band can apply at these temperatures.

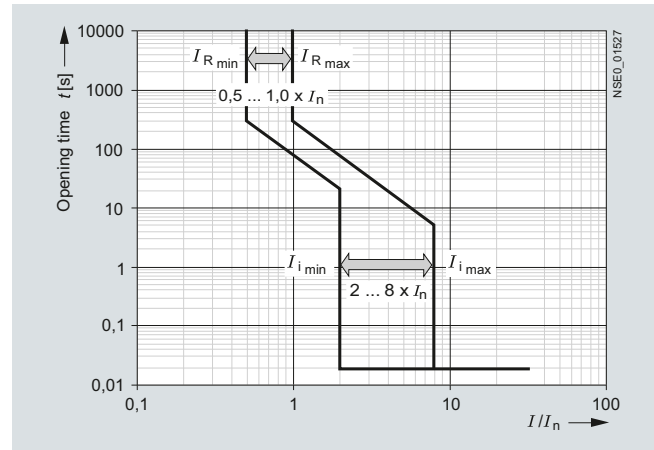

3WL circuit breaker with ETU15B electronic trip unit

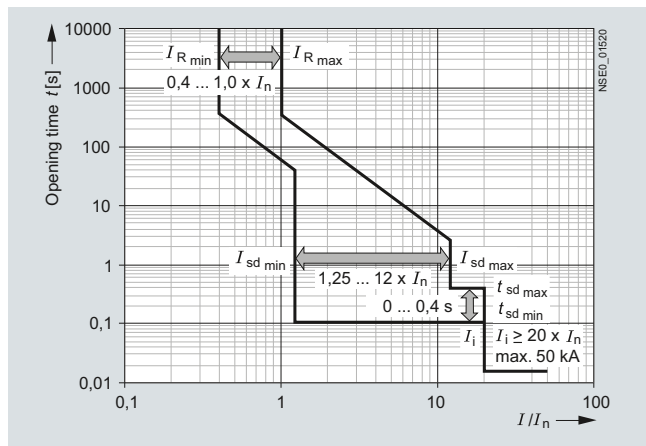

3WL circuit breaker with ETU25B electronic trip unit, LSI characteristic curve

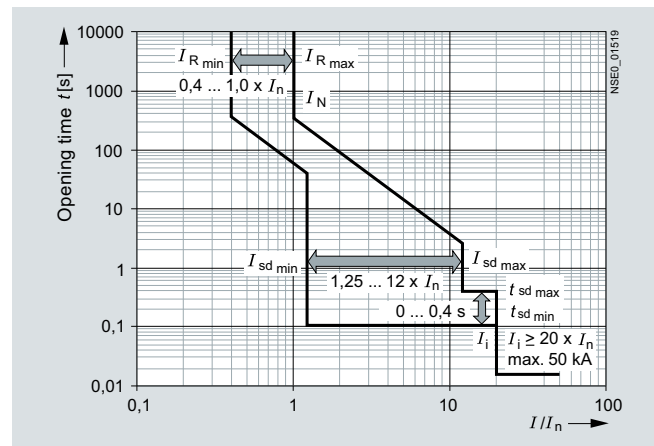

3WL circuit breaker with ETU27B electronic trip unit, LSIN characteristic curve

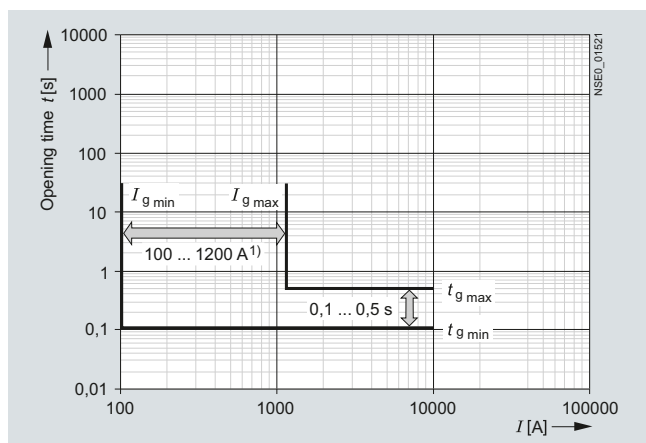

3WL circuit breaker with ETU27B electronic trip unit, G characteristic curve

Tolerances for the current settings

L: tripping operations between 1.05 and 1.2 x I_R

S: -0 %, +20 %

I: -0 %, +20 %

G: -0 %, +20 %

Tolerances for the tripping times

L: -20 %, +0 % for I²t characteristic curve

S: -0 %, +60 ms or -0 %, 10 % for tripping times greater than 600 ms

I: <50 ms

G: -0 %, +60 ms or -0 %, 10 % for tripping times greater than 600 ms

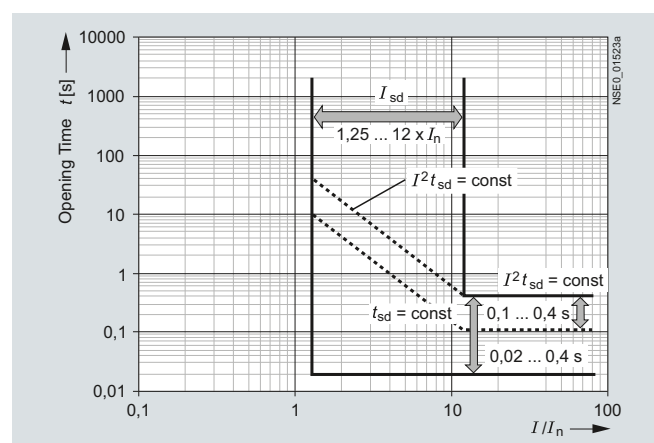

3WL circuit breaker with ETU45B electronic trip unit, S characteristic curve

¹⁾ Sizes I and II: 100 ... 1200 A

Size III: 400 ... 1200 A

²⁾ With a single-pole load in the lowest rated current range, the response times of the short-circuit trip can increase by approx. 10 % and the tripping times by approx. 15 % with respect to the characteristic curve.

3WL Air Circuit Breakers

3WL air circuit breakers/non-automatic air circuit breakers up to 6300 A (AC), IEC

Project planning aids

Every electronic trip unit type and every setting has its own characteristic curve. Only a selection is shown in the following. The characteristic curves each show the largest and smallest setting range of 3WL circuit breakers with 1000 A rated current at 500 V rated voltage with various trip units.

In order to obtain a complete tripping characteristic, the relevant parts of the characteristics have to be combined.

The characteristic curves show the behavior of the electronic trip unit when it is activated by a current that is already flowing before the tripping operation. If the overcurrent tripping occurs immediately after closing and the electronic trip unit is therefore not yet activated, the opening time is extended, depending on the level of the overcurrent by up to 15 ms. In order to determine the total break-times of the circuit breakers, approximately 15 ms must be added to the opening times shown for the arcing time.

Refer to the following legend for tolerances.

The characteristic curves shown apply to ambient temperatures at the circuit breaker between -5 and +55°C. The trip unit can be operated at ambient temperatures of -20 to +70°C (ETU76B with graphic display up to +55 °C). An extended tolerance band can apply at these temperatures.

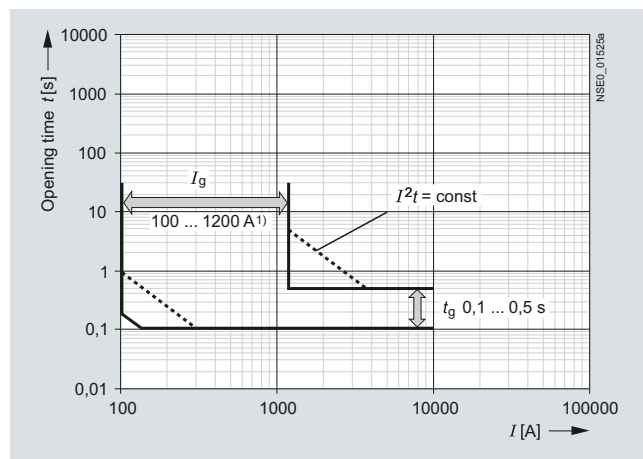

3WL circuit breaker with ETU45B and ETU76B electronic trip unit, G characteristic curve

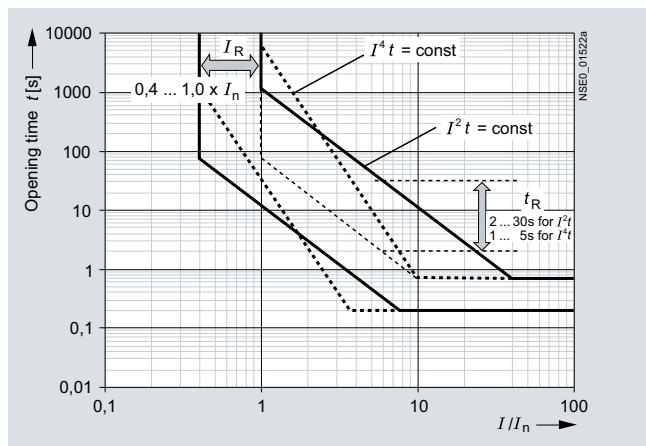

3WL circuit breaker with ETU45B and ETU76B electronic trip unit, L characteristic curve

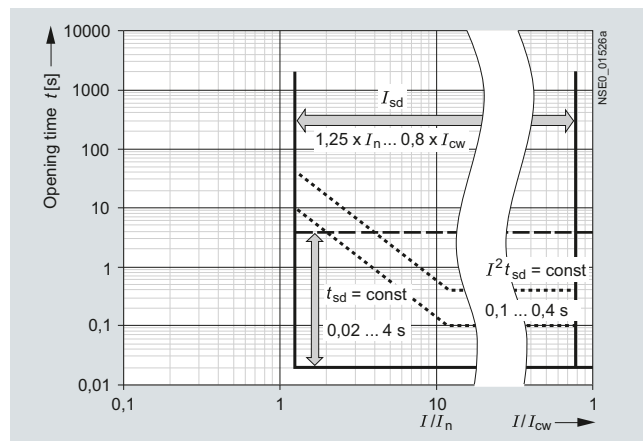

3WL circuit breaker with ETU76B electronic trip unit, S characteristic curve

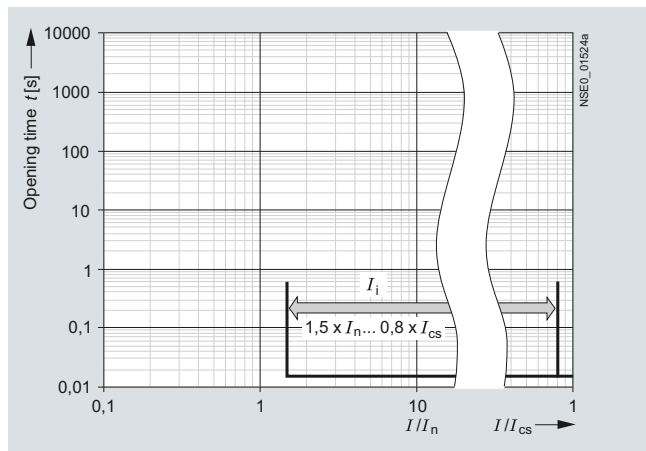

3WL circuit breaker with ETU45B and ETU76B electronic trip unit, I characteristic curve

1) Sizes I and II: 100 ... 1200 A
Size III: 400 ... 1200 A

Further characteristic curves are shown in the manual and the planning and configuring tool SIMARIS design, or ask your Siemens contact person.

- Tolerances for the current settings
- L: tripping operations between 1.05 and 1.2 × I_R
 - S: -0 %, +20 %
 - I: -0 %, +20 %
 - G: -0 %, +20 %

- Tolerances for the tripping times
- L: -20 %, +0 % for $I^2 t$ characteristic curve
 - S: -0 %, +60 ms or -0 %, 10 % for tripping times greater than 600 ms
 - I: <50 ms
 - G: -0 %, +60 ms or -0 %, 10 % for tripping times greater than 600 ms

Dimensional drawings

Voltage transformers for 3WL air circuit breakers

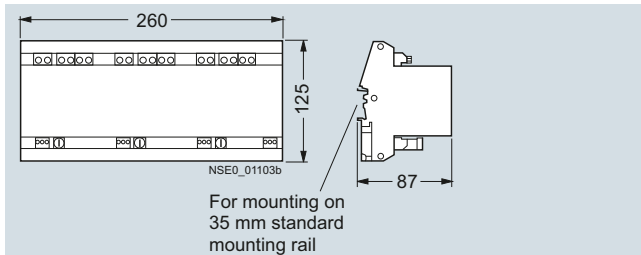

Current transformers for overload protection in the N conductor

External current transformers for N conductor with copper connection pieces

Size I, 3WL9 111-0AA31-0AA0

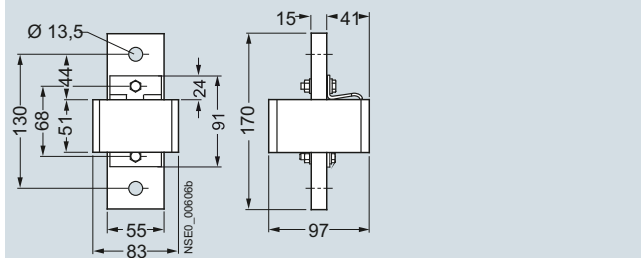

Size II, 3WL9 111-0AA32-0AA0

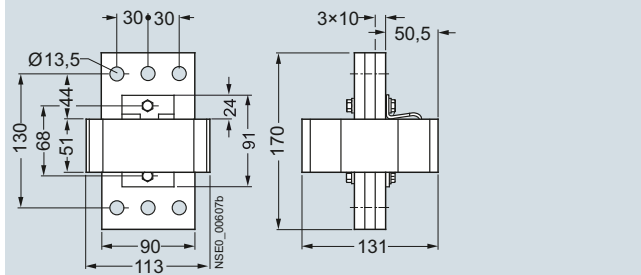

Size III, 3WL9 111-0AA33-0AA0

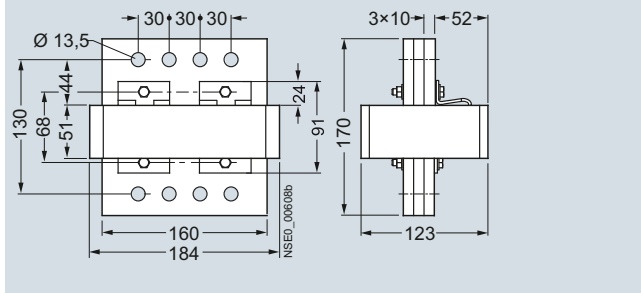

External current transformers for N conductor without copper connection pieces

Size I, 3WL9 111-0AA21-0AA0

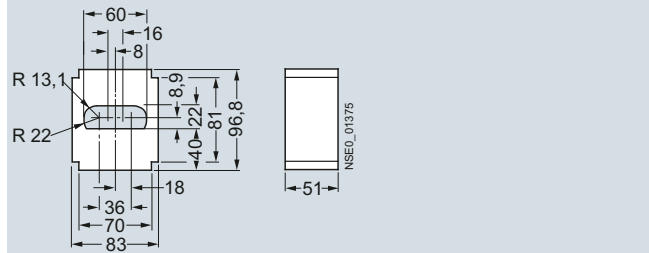

Size II, 3WL9 111-0AA22-0AA0

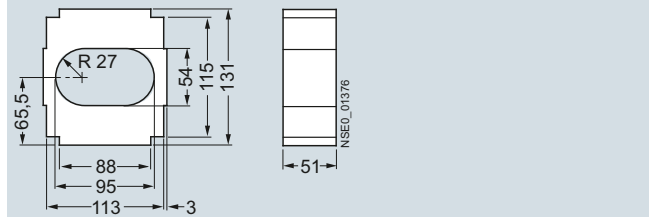

Size III, 3WL9 111-0AA23-0AA0

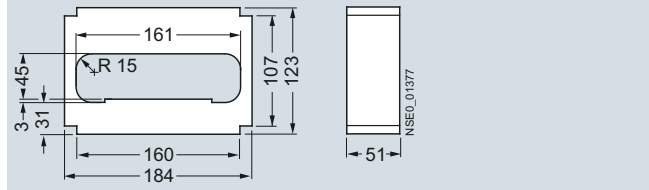

Door cutout for operator panel

Door cutout with edge protector

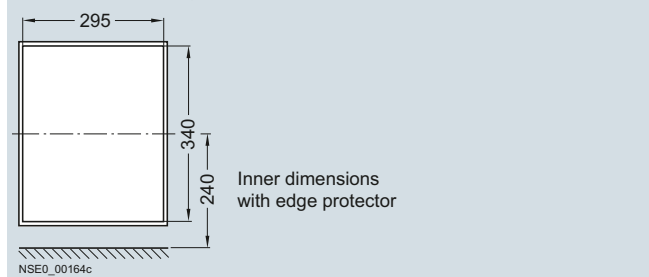

Door cutout for operator panel using the door sealing frame

Option with/without door interlocking

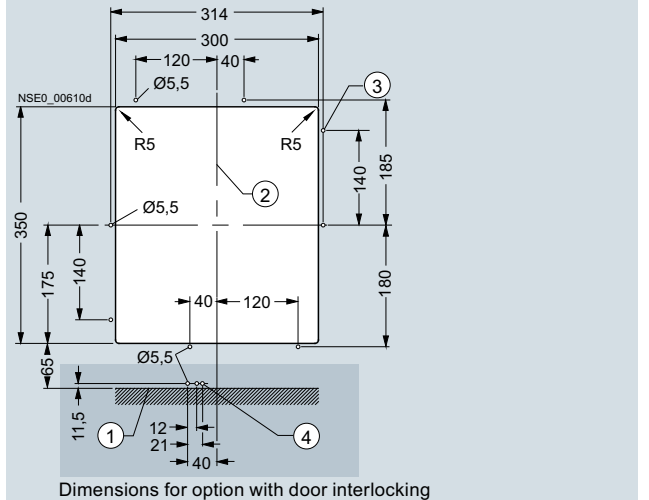

Dimensions for option with door interlocking

- 1) Mounting surface
- 2) Center 3WL circuit breaker operator panel
- 3) 8 mounting holes for door sealing frame
- 4) 3 mounting holes for door interlocking

3WL Air Circuit Breakers

3WL air circuit breakers/non-automatic air circuit breakers up to 6300 A (AC), IEC

Project planning aids

CubicleBUS modules

3WL9 111-0AT2.-0AA0

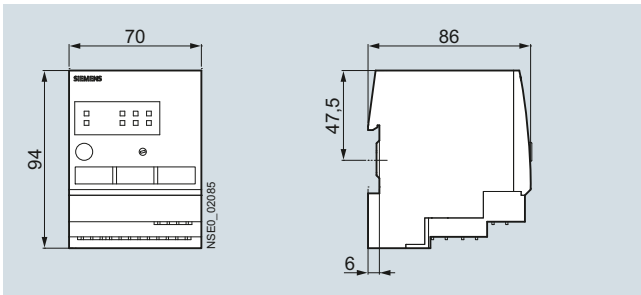

Breaker Data Adapter (BDA Plus)

3WL9 111-0AT33-0AA0

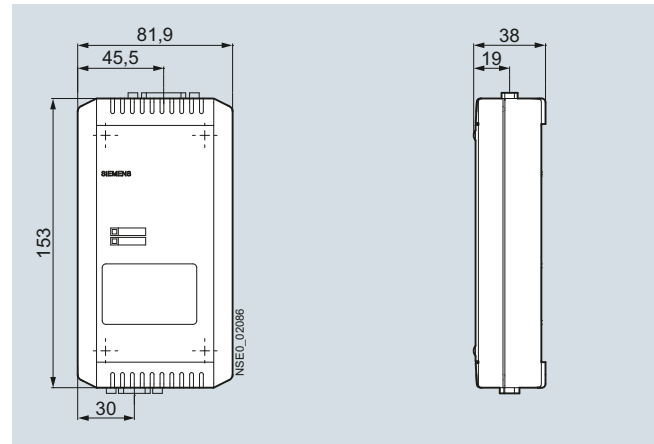

Door cutout for operator panel using protective cover IP55

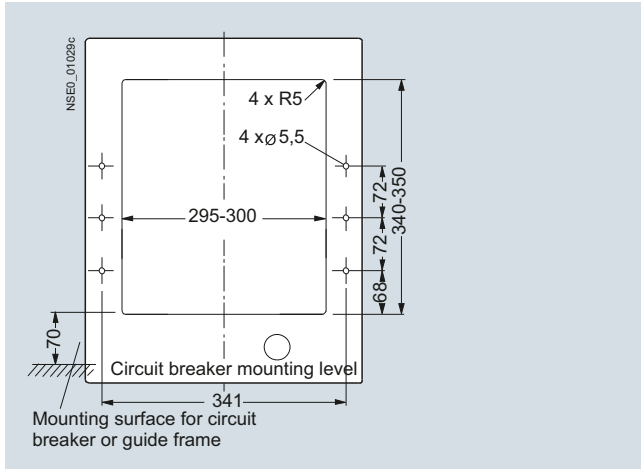

Protective cover, IP55

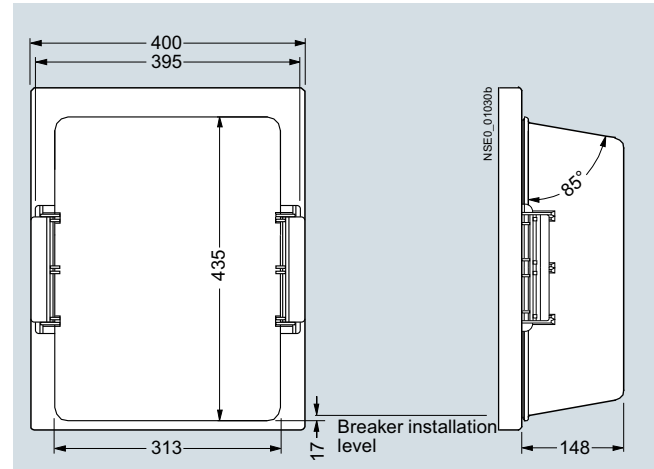

Safety clearances from grounded parts

Rated operational voltage V/AC	Above auxiliary connector mm	Lateral (each side) mm	Rear mm
Size I, fixed-mounted version			
500	75 ¹⁾	0	0
690	75 ¹⁾	0	0
Size I, withdrawable version, without arc chute cover			
500	50 ¹⁾	0	0
690	50 ¹⁾	0	0
Size I, withdrawable version, with arc chute cover			
500	0	0 ²⁾	0
690	0	0 ²⁾	0
Size II, fixed-mounted version			
500	75 ¹⁾	0	0
690	75 ¹⁾	0	0
1000	180	0	0
Size II, withdrawable version, without arc chute cover			
500	50 ¹⁾	0	0
690	50 ¹⁾	0	0
1000	100	0	0
Size II, withdrawable version, with arc chute cover			
500	0	0 ²⁾	0
690	0	0 ²⁾	0
Size III, fixed-mounted version			
500	75 ¹⁾	0	0
690	75 ¹⁾	0	0
1000	180	0	0
Size III, withdrawable version, without arc chute cover			
500	50 ¹⁾	0	0
690	50 ¹⁾	0	0
1000	100	0	0
Size III, withdrawable version, with arc chute cover			
500	0	0 ²⁾	0
690	0	0 ²⁾	0
DC non-automatic air circuit breakers			
300	45	0	0
600	200	0	0
1000	150	0	0

Please note: All safety clearances above the circuit breaker refer to the upper edge of the auxiliary connector – not to the upper edge of the arc chute, see dimensional drawings on pages 42 to 48, parts 4) and 5).

Safety clearances from live parts

Rated operational voltage V/AC	Above auxiliary connector mm	Lateral (each side) mm	Rear mm
Size I, fixed-mounted version			
500	150	20	20
690	300	50	125
1000	500 ³⁾	100 ³⁾	140 ³⁾
Size I, withdrawable version, without arc chute cover			
500	150	20	14
690	300	50	14
1000	500 ³⁾	100 ³⁾	140 ³⁾
Size I, withdrawable version, with arc chute cover			
500	14	100	14
690	14	100	14
Size II, fixed-mounted version			
500	250	50	20
690	600	100	140
1000	430	100	125
Size II, withdrawable version, without arc chute cover			
500	250	50	14
690	600	100	30
1000	350	100	14
Size II, withdrawable version, with arc chute cover			
500	14	50	14
690	14	225	14
Size III, fixed-mounted version			
500	75	20	20
690	500	100	125
1000	430	100	125
Size III, withdrawable version, without arc chute cover			
500	50	20	14
690	500	100	14
1000	350	100	14
Size III, withdrawable version, with arc chute cover			
500	14	50	14
690	14	200	14

¹⁾ Value for plate; 0 mm for struts and grids.

²⁾ 40 mm (size II: 70 mm) for plates which cover the lateral openings in the guide frame.

³⁾ Not for breaking capacity S.

3WL Air Circuit Breakers

3WL air circuit breakers/non-automatic air circuit breakers up to 6300 A (AC), IEC

Project planning aids

Size I, up to 2000 A, fixed-mounted version, 3- and 4-pole

Standard version

Horizontal connection

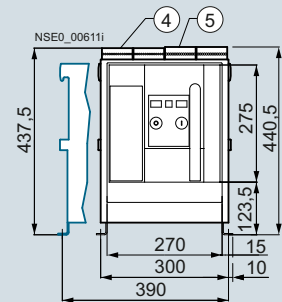

Optional connection variants

Front connection (single)

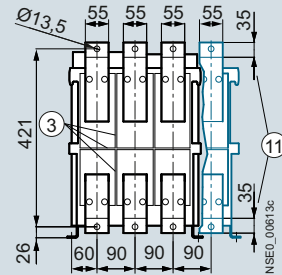
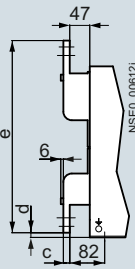

Front connection (double hole) according to DIN 43673

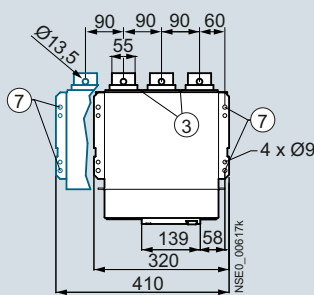
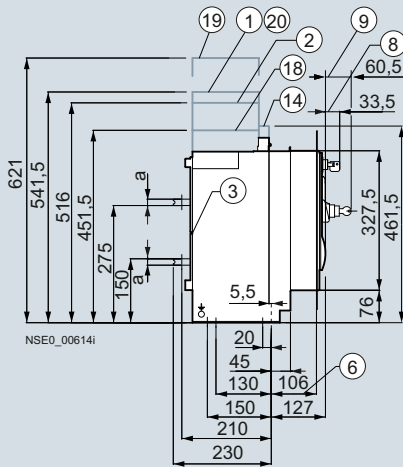
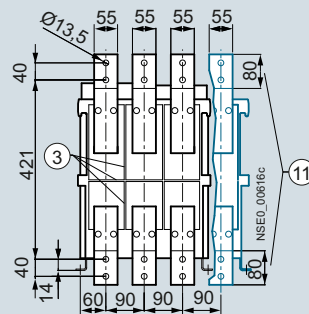
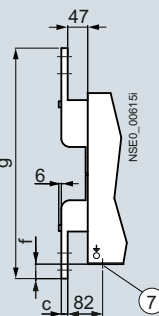

Vertical connection

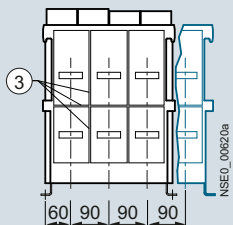
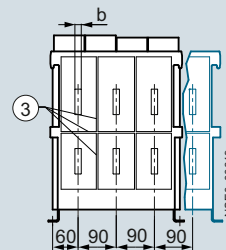
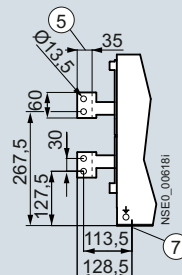

General

Rated circuit breaker current A	a	b	c	d	e	f	g
Up to is 1000 A (AC) ^⑫	10	10	10	11	451	34	541
1250 ... 2000 A (AC), DC ≤ 2000 A or breaking capacity H	15	20	15	6	461	39	551

Blue lines: 4-pole version

- ① Mounting space for removal of the arc chutes
- ② Arc quenching space, space for electrical auxiliary circuit connections
- ③ Grooves (4 mm wide, 5 mm deep) for supporting phase partitions in the system
- ④ Auxiliary connector with SIGUT screw terminals
- ⑤ Auxiliary connector with spring-type connections
- ⑥ Dimension to inside surface of the closed cabinet door
- ⑦ Fixing points for mounting the circuit breaker in the system
- ⑧ "Secure OFF" locking device
- ⑨ Key operation
- ⑩ Terminal face

- ⑪ Space for electrical auxiliary circuit connections
- ⑫ Circuit breaker upper edge, only 690 V +20 % and 1000 V circuit breaker
- ⑬ Arc quenching space facing grounded or non-conductive surfaces, only 690 V +20 % and 1000 V circuit breaker
- ⑭ Arc quenching space facing grounded or non-conductive surfaces, only circuit breakers with breaking capacity class C
- ⑮ Only for breaking capacity N and S

Safety clearances to grounded parts and to live parts, see page 41.

3WL Air Circuit Breakers

3WL air circuit breakers/non-automatic air circuit breakers up to 6300 A (AC), IEC

Project planning aids

Size I, up to 2000 A, withdrawable version, 3- and 4-pole

Standard version

Horizontal connection

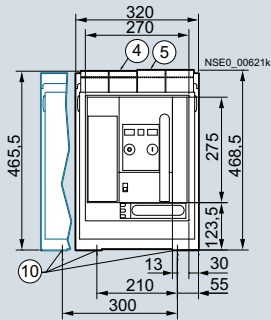

Optional connection variants

Vertical connection

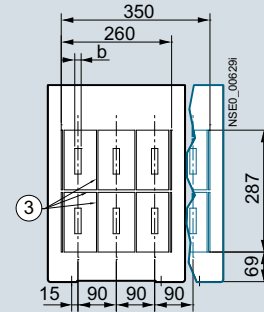
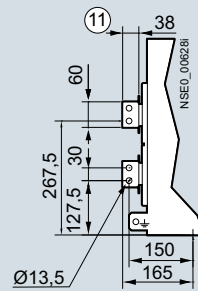

Flange connection

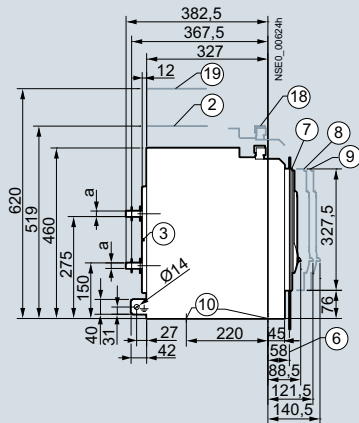
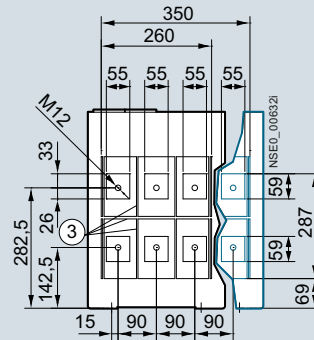
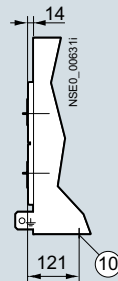

Front connection (single)

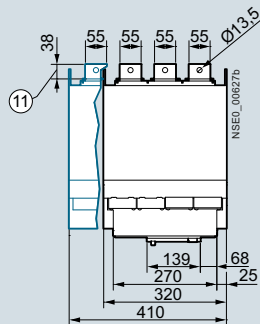
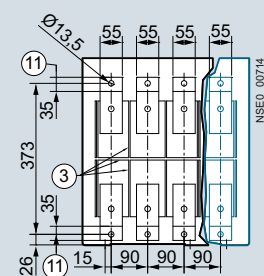
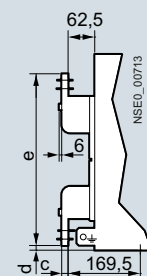

Front connection (double hole) according to DIN 43673

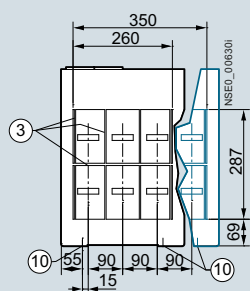
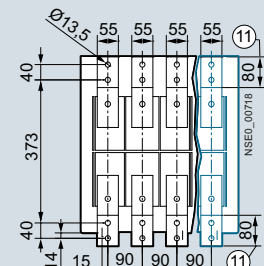
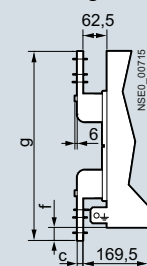

Blue lines: 4-pole version

- ③ Grooves (4 mm wide, 5 mm deep) for supporting phase partitions in the system
- ④ Auxiliary connector with SIGUT screw terminals
- ⑤ Auxiliary connector with spring-type connections
- ⑥ Dimension to inside surface of the closed cabinet door
- ⑦ 3WL5 in operating position
- ⑧ 3WL5 in test position
- ⑨ 3WL5 in disconnected position
- ⑩ Fixing holes 9 mm
- ⑪ Terminal face
- Ⓜ Circuit breaker upper edge, only 690 V +20 % and 1000 V circuit breaker

- Ⓜ Arc quenching space facing grounded or non-conductive surfaces, only 690 V +20 % and 1000 V circuit breaker
- Ⓜ Only for breaking capacity N and S

Rated circuit breaker current (A)	a	b	c	d	e	f	g
Up to 1000 A (AC) Ⓜ	10	10	10	11	403	34	493
1250 ... 2000 A (AC) or breaking capacity H	15	15	15	6	413	39	503

Safety clearances to grounded parts and to live parts, see page 41.

3WL Air Circuit Breakers

3WL air circuit breakers/non-automatic air circuit breakers up to 6300 A (AC), IEC

Project planning aids

Size II, up to 4000 A, fixed-mounted version, 3- and 4-pole

Standard version

Horizontal connection

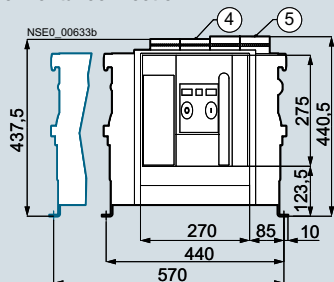

Optional connection variants

Front connection (single)

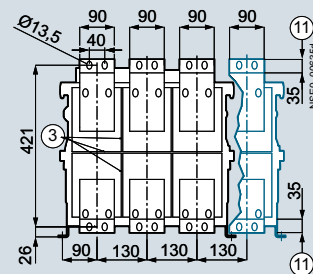
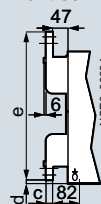

Front connection (double hole) according to DIN 43673

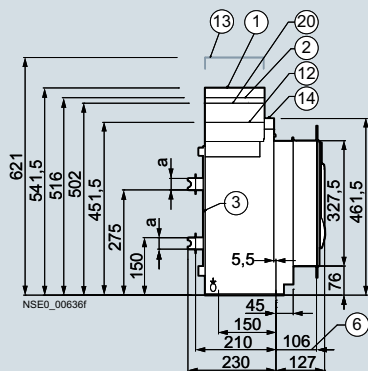
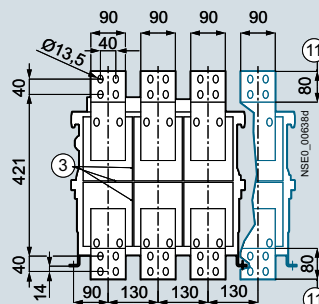
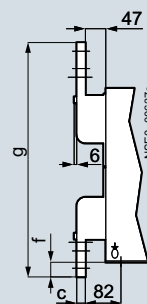

Vertical connection up to 3200 A

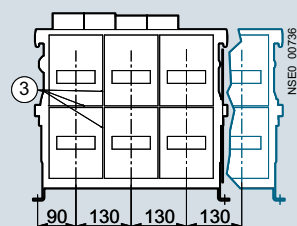
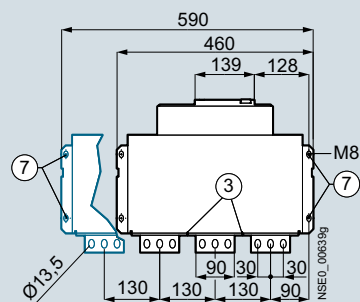
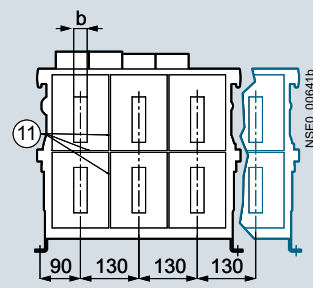
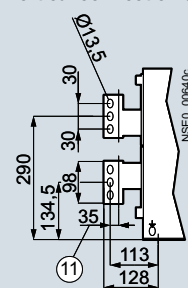

General

Rated circuit breaker current A	a	b	c	d	e	f	g
Up to 1600	10	15	10	11	451	34	541
2500	15	15	20	6	461	39	551
Up to 3200	30	30	20	6	461	39	551

Blue lines: 4-pole version

- ① Mounting space for removal of the arc chutes
- ② Arc quenching space, space for electrical auxiliary circuit connections
- ③ Grooves (4 mm wide, 5 mm deep) for supporting phase partitions in the system
- ④ Auxiliary connector with SIGUT screw terminals
- ⑤ Auxiliary connector with spring-type connections
- ⑥ Dimension to inside surface of the closed cabinet door
- ⑦ Fixing points for mounting the circuit breaker in the system
- ⑧ Terminal face
- ⑨ Circuit breaker upper edge, only 1000 V, 1150 V and circuit breakers with breaking capacity class C, 3WL1 circuit breaker only
- ⑩ Arc quenching space, 1000 V circuit breaker facing grounded or non-conductive surfaces
- ⑪ Space for electrical auxiliary circuit connections
- ⑫ Arc quenching space, 300 V circuit breaker facing grounded or non-conductive surfaces
- ⑬ Arc quenching space, 600 V circuit breaker facing grounded or non-conductive surfaces
- ⑭ Circuit breaker upper edge, only 1000 V, 1150 V and circuit breakers with breaking capacity class C
- ⑮ Arc quenching space facing grounded or non-conductive surfaces, only circuit breakers with breaking capacity class C

Safety clearances to grounded parts and to live parts, see page 41.

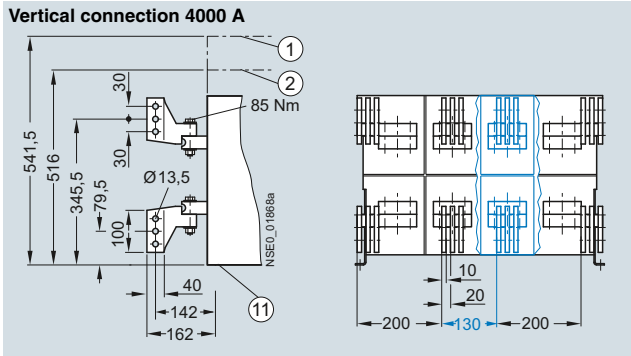
Size II, up to 4000 A, fixed-mounted version, 3- and 4-pole

- ① Mounting space for removal of the arc chutes
- ② Arc quenching space, "Ⓜ 690 V" circuit breaker facing grounded or non-conductive surfaces
- Ⓜ Terminal face

Safety clearances to grounded parts and to live parts, [see page 41](#).

More connection options, [see previous page](#).

3WL Air Circuit Breakers

3WL air circuit breakers/non-automatic air circuit breakers up to 6300 A (AC), IEC

Project planning aids

Size II, up to 4000 A, withdrawable version, 3- and 4-pole

Standard version

Horizontal connection

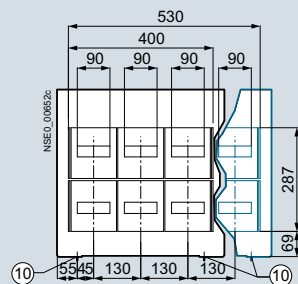
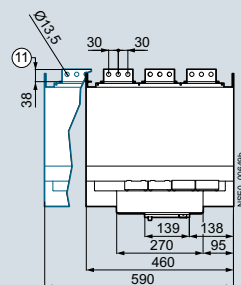
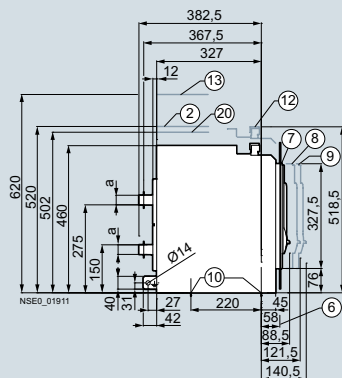
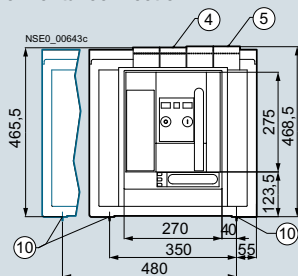

Optional connection variants

Vertical connection up to 3200 A

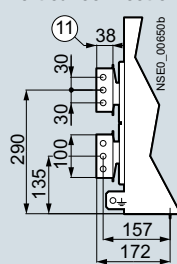

Flange connection

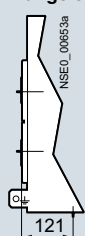

Front connection (single)

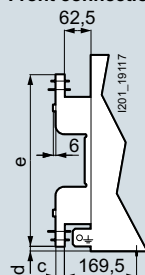

Front connection (double hole) according to DIN 43673

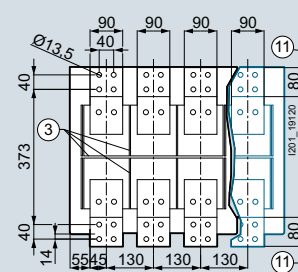
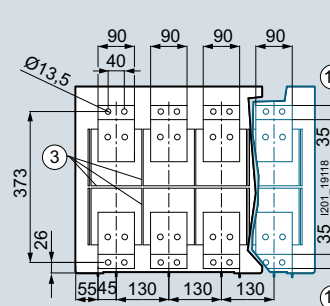
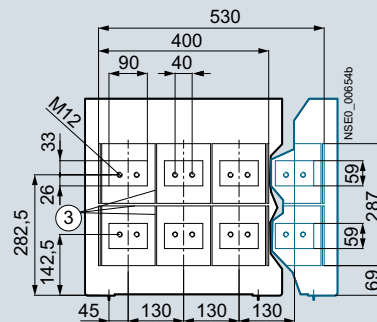
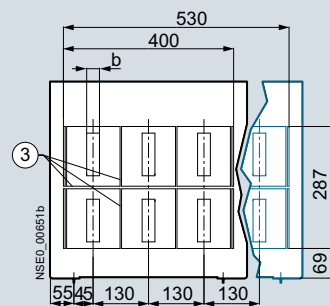
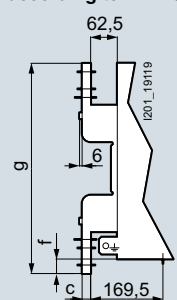

Blue lines: 4-pole version

- ③ Grooves (4 mm wide, 5 mm deep) for supporting phase partitions in the system
- ④ Auxiliary connector with SIGUT screw terminals
- ⑤ Auxiliary connector with spring-type connections
- ⑥ Dimension to inside surface of the closed cabinet door
- ⑦ 3WL in operating position
- ⑧ 3WL in test position
- ⑨ 3WL in disconnected position
- ⑩ Fixing holes, diameter 9 mm
- ⑪ Terminal face

More details, see page 41

Rated circuit breaker current (A)	a	b	c	d	e	f	g
Up to 2000	10	15	10	11	403	34	493
2500	15	15	20	6	413	39	503
3200	30	30	20	6	413	39	503

Safety clearances to grounded parts and to live parts, see page 41.

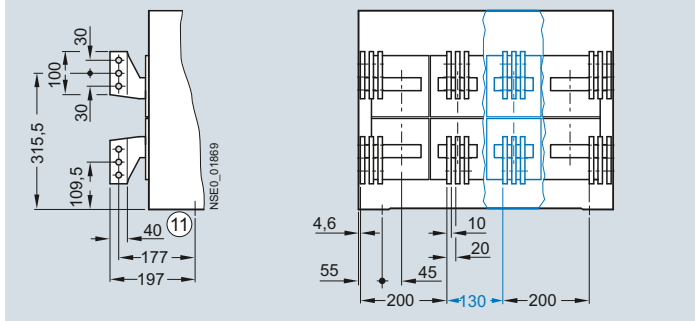
Size II, up to 4000 A, withdrawable version, 3- and 4-pole**Vertical connection 4000 A**

⑪ Terminal face

Safety clearances to grounded parts and to live parts, see [page 41](#).

More connection options, see [previous page](#).

3WL Air Circuit Breakers

3WL air circuit breakers/non-automatic air circuit breakers up to 6300 A (AC), IEC

Project planning aids

Size III, up to 6300 A, fixed-mounted version, 3- and 4-pole

Standard version

Horizontal connection

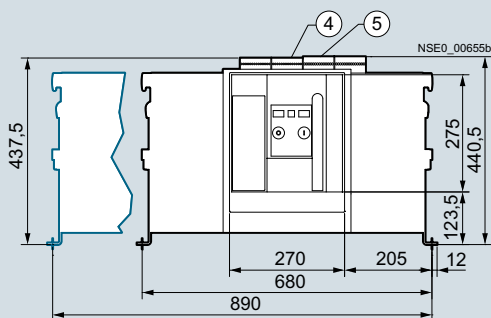

Optional connection variants

Front connection (single)

Up to 4000 A

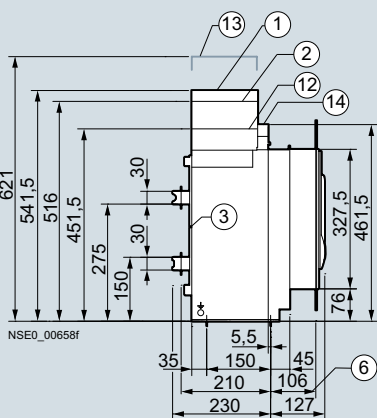
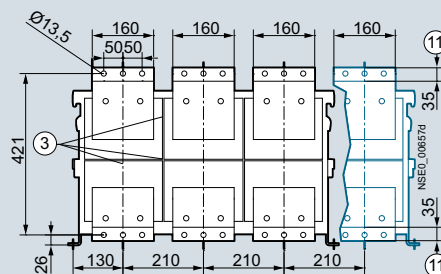
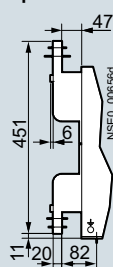

Vertical connection

Up to 6300 A

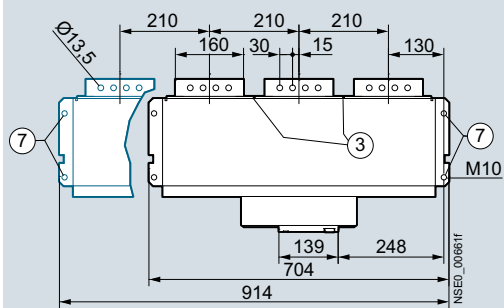
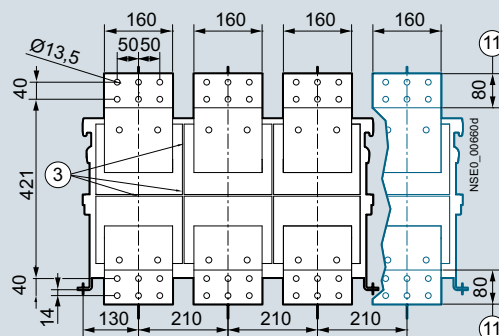
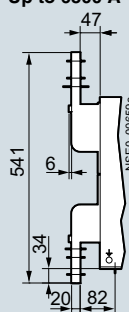

Vertical connection

Up to 6300 A

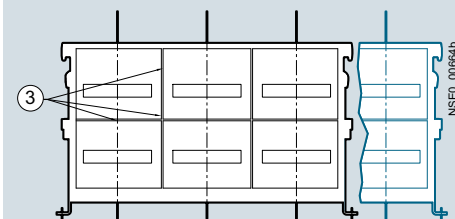
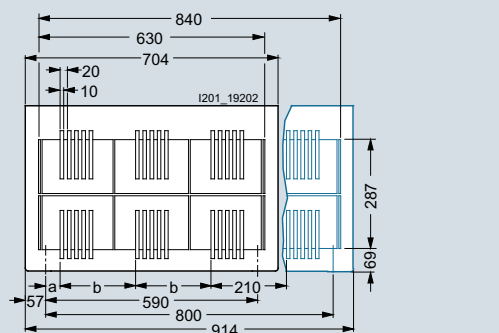
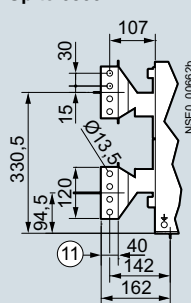

Blue lines: 4-pole version

- ① Mounting space for removal of the arc chutes
- ② Arc quenching space, space for electrical auxiliary circuit connections
- ③ Grooves (4 mm wide, 5 mm deep) for supporting phase partitions in the system
- ④ Auxiliary connector with SIGUT screw terminals
- ⑤ Auxiliary connector with spring-type connections
- ⑥ Dimension to inside surface of the closed cabinet door
- ⑦ Fixing points for mounting the circuit breaker in the system
- ⑩ Terminal face

- ⑫ Circuit breaker upper edge, only 1000 V circuit breakers and circuit breakers with breaking capacity class C
- ⑬ Arc quenching space, 1000 V circuit breaker and circuit breaker with breaking capacity C facing grounded or non-conductive surfaces
- ⑭ Space for electrical auxiliary circuit connections

Safety clearances to grounded parts and to live parts, see page 41.

3WL Air Circuit Breakers

3WL air circuit breakers/non-automatic air circuit breakers up to 6300 A (AC), IEC

Project planning aids

Size III, up to 6300 A, withdrawable version, 3- and 4-pole

Standard version

Horizontal connection, up to 5000 A

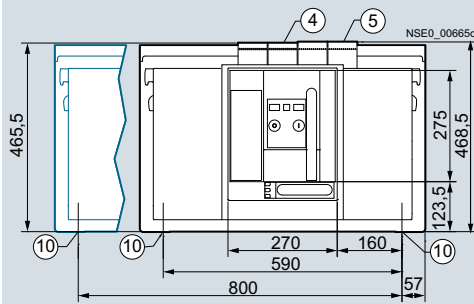

Optional connection variants

Vertical connection up to 6300 A

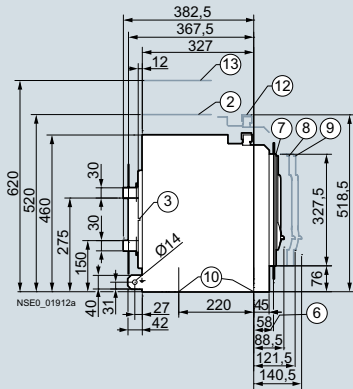
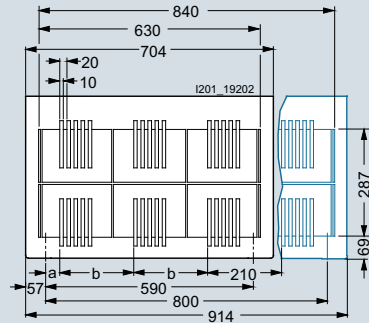
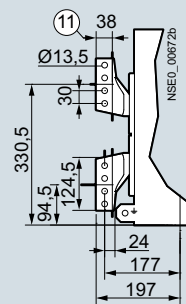

Flange connection, up to 4000 A

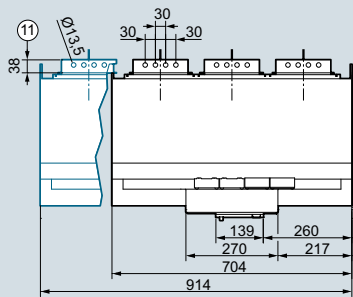
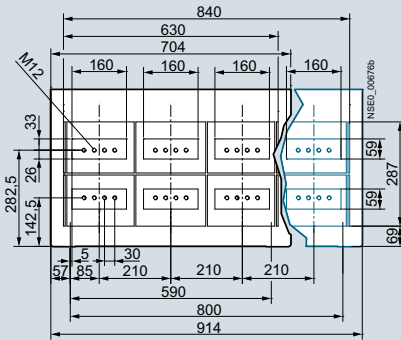
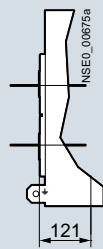

Front connection (single)

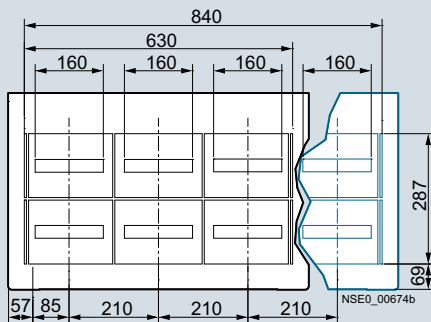
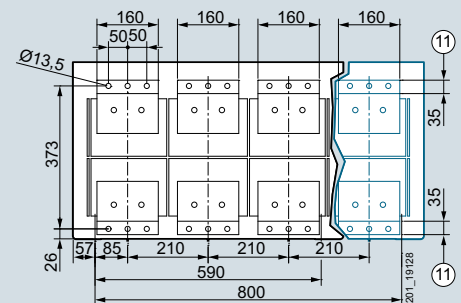
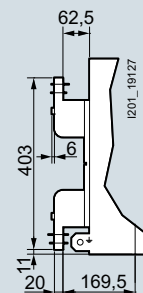

Front connection (double hole) according to DIN 43673

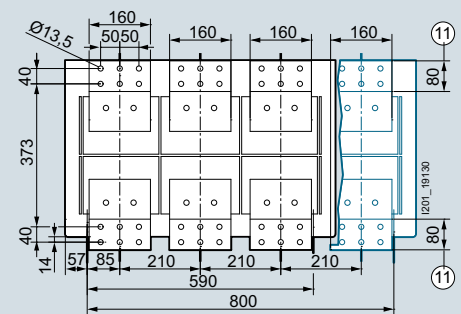
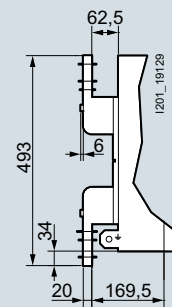

Blue lines: 4-pole version

- ③ Grooves (4 mm wide, 5 mm deep) for supporting phase partitions in the system
- ④ Auxiliary connector with SIGUT screw terminals
- ⑤ Auxiliary connector with spring-type connections
- ⑥ Dimension to inside surface of the closed cabinet door
- ⑦ 3WL in operating position
- ⑧ 3WL in test position
- ⑨ 3WL in disconnected position
- ⑩ Fixing holes, diameter 9 mm
- ⑪ Terminal face

- ⑫ Circuit breaker upper edge, only 1000 V circuit breakers and circuit breakers with breaking capacity C
- ⑬ Arc quenching space, 1000 V circuit breaker and circuit breaker with breaking capacity C facing grounded or non-conductive surfaces

Safety clearances to grounded parts and to live parts, see page 41.

Rated circuit breaker current A	a	b
4000	40	210
5000	40	210
6300	5	245

3WL Air Circuit Breakers

3WL air circuit breakers/non-automatic air circuit breakers up to 6300 A (AC), IEC

Project planning aids

Circuit diagrams

Terminal assignment diagram

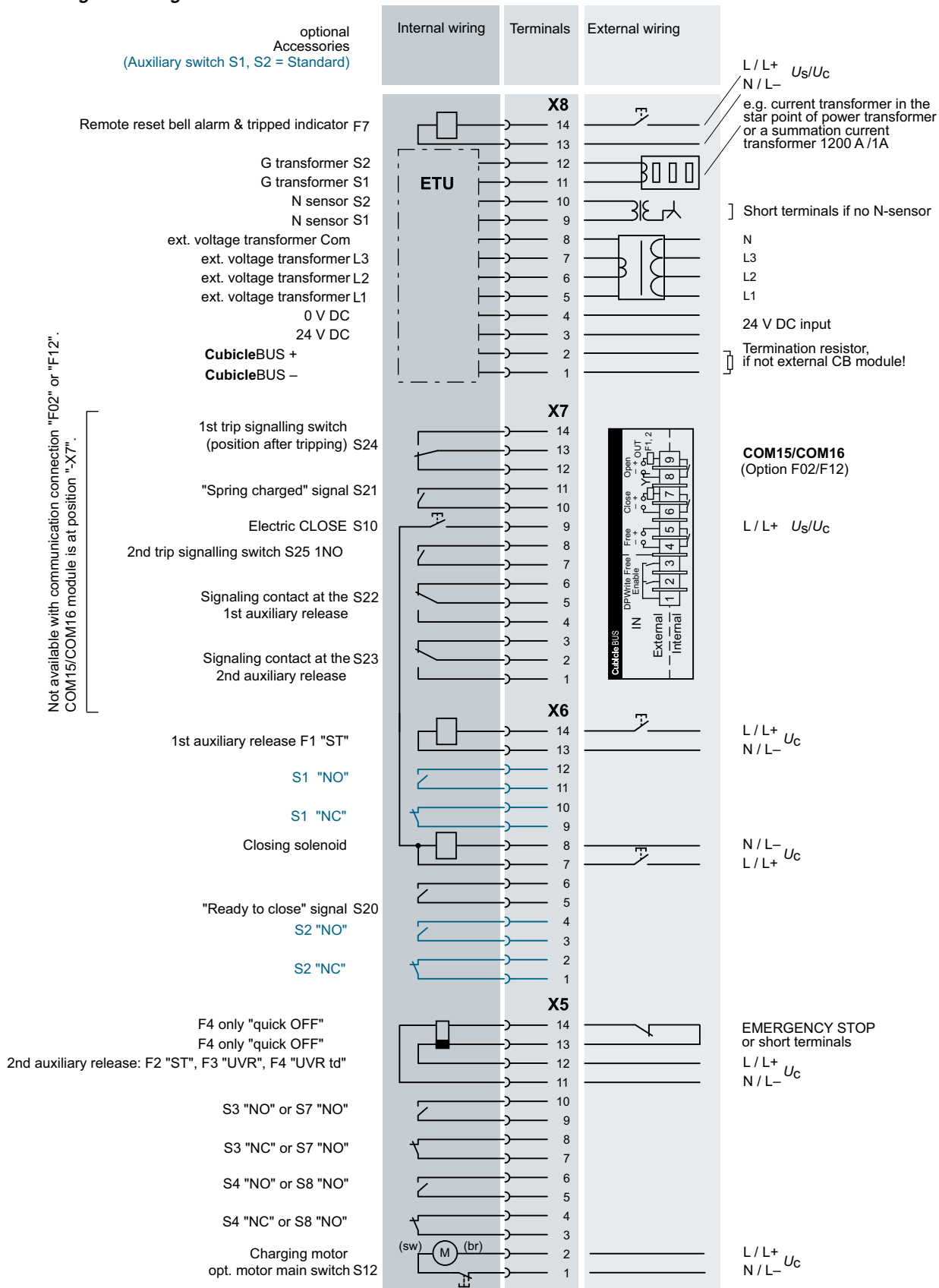

Not available with communication connection "F02" or "F12".
COM15/COM16 module is at position "-X7".

3WL Air Circuit Breakers

3WL air circuit breakers/non-automatic air circuit breakers up to 6300 A (AC), IEC

Project planning aids

Example of an overall circuit diagram for 3WL circuit breakers

(3WL1...-4GN4-Z C11+C22+K07)

Manual / motorized operating mechanism with stored-energy feature, with electric ON button (option C11), with ready-to-close

signaling switch (option C22), with electronic trip unit LSING with undervoltage release "UVR" (F3), with shunt trip "ST" (F1), with trip alarm switch (option K07), with auxiliary switch 4 NO + 4 NC.

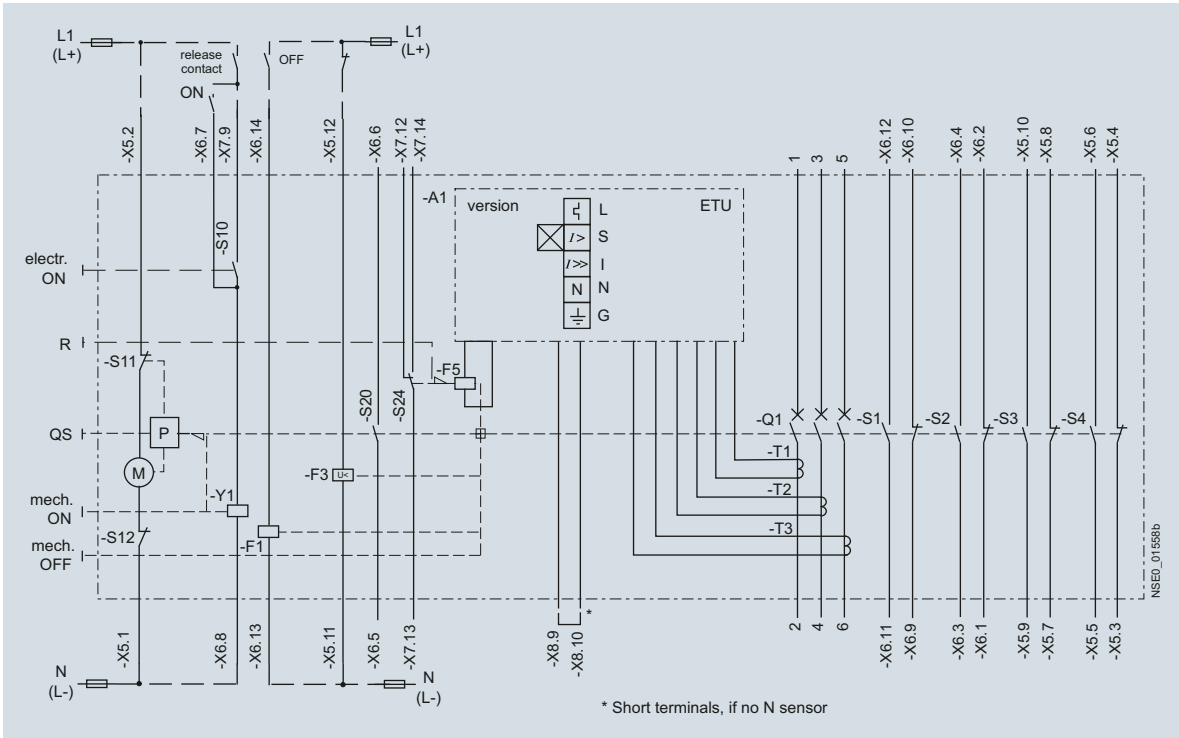

Function diagram of 3WL air circuit breaker

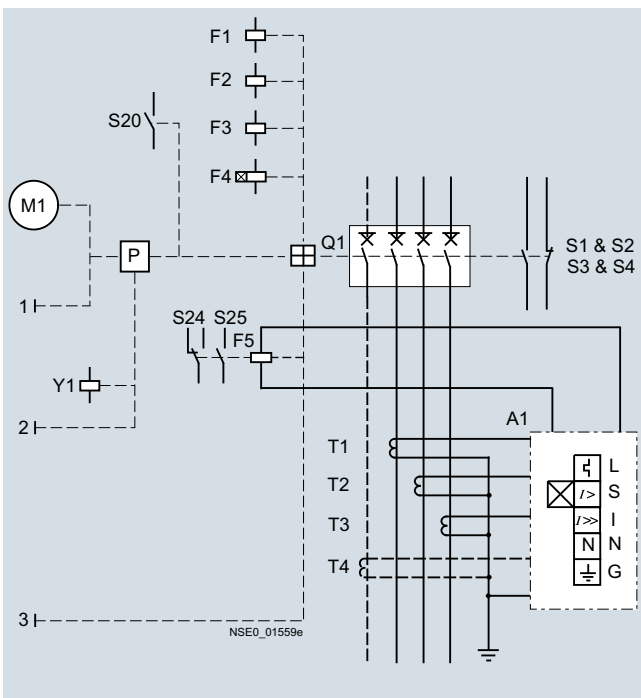

- A1 ETU electronic trip unit
- S1/-S2 1st auxiliary switch block (2 NO + 2 NC)
- S3/-S4 2nd auxiliary switch block (2 NO + 2 NC)
- S7 (optional) 2nd auxiliary switch block, S7 (2 NO) can be used if there is no S3 – S3 and S7 have the same terminal assignment/mounting location
- S8 (optional) 2nd auxiliary switch block, S8 (2 NO) can be used if there is no S4 – S4 and S8 have the same terminal assignment/mounting location
- 3WL1...-2 (2 NO + 2 NC) S1+S2
- 3WL1...-4 (4 NO + 4 NC) S1+S2+S3+S4
- 3WL1...-7 (6 NO + 2 NC) S1+S2+S7+S8
- 3WL1...-8 (5 NO + 3 NC) S1+S2+S3+S8
- S10 Electrical ON button
- S11 Internal motor shutdown switch (if spring is tensioned)
- S12 Motor shutdown switch (no automatic tensioning of spring)
- S20 Ready-to-close signaling switch
- S24 Trip alarm switch
- F1 1st auxiliary release shunt release
- F3 2nd auxiliary release undervoltage release
- F5 Tripping solenoid
- M Motor for "charging energy store"
- P Stored-energy mechanism
- QS Actuator lever for "charging energy store"
- Q1 Main contacts
- T1/-T2/-T3 Current transformers
- X5/-X6/-X7/-X8 Terminals
- Y1 Closing solenoid
- R Display and reset button for electronic trip unit
- X8.9/-X8.10 Connection option: external N transformer

3WL Air Circuit Breakers

3WL air circuit breakers/non-automatic air circuit breakers up to 6300 A (AC), IEC

Project planning aids

Example of the mode of operation of Zone Selective Interlocking functionality in power distribution

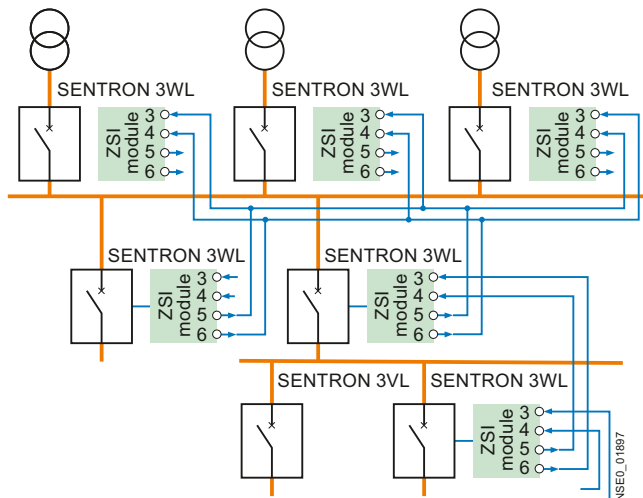

3VL and 3WL circuit breakers used in various staggered levels

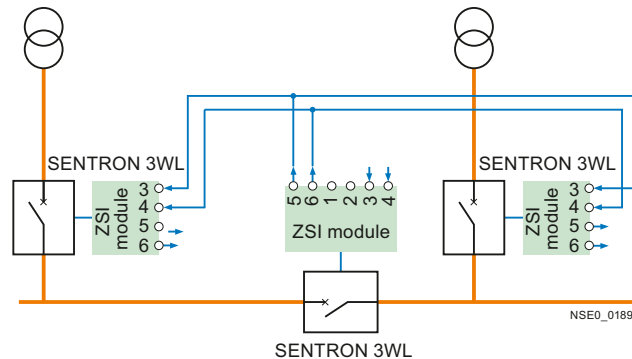

Circuit diagram for a Zone Selective Interlocking functionality with multiple infeed and several outgoing units with 3WL circuit breakers

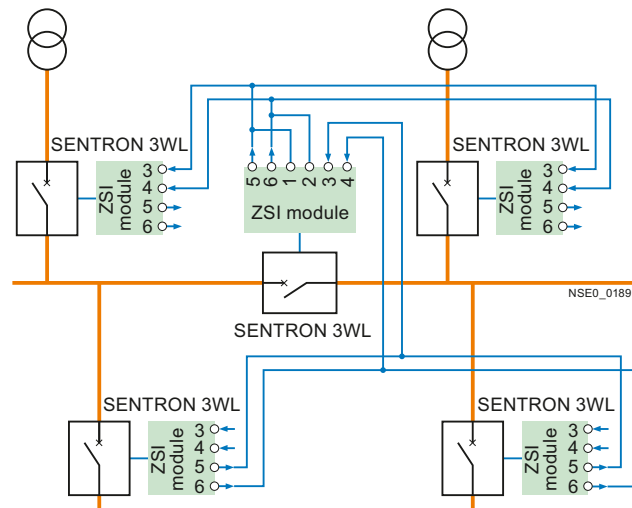

ZSI function: Connection using a coupling switch, use of 3WL circuit breakers

More information

Up-to-date information on the Internet at:
<http://www.siemens.com/sentron>

Technical specifications

Size		I	II		
Type		3WL11 20	3WL12 10	3WL12 20	3WL12 40
Rated current I_n at 40 °C					
Main conductor	A	2000	... 1000	2000	4000
Rated operational voltage U_e (1000 V version, see Catalog LV 10, order code *A05*)	V DC	1000	... 600/1000	... 600/1000	... 600/1000
Rated insulation voltage U_i	V DC	1000	1000	1000	1000
Rated impulse withstand voltage U_{imp}					
• Main conducting paths	kV	12	12	12	12
• Auxiliary circuits	kV	4	4	4	4
• Control circuits	kV	2.5	2.5	2.5	2.5
Isolating function acc. to EN 60947-2		Yes	Yes	Yes	Yes
Utilization category		B			
Permissible ambient temperature					
• Operation	°C	-25/+70	-25/+70	-25/+70	-25/+70
• Storage	°C	-40/+70	-40/+70	-40/+70	-40/+70
Permissible load					
Up to 40 °C	A	2000	1000	2000	4000
At rear horizontal main connections (Cu painted black)	A	1910	1000	2000	3640
Up to 55 °C	A	1850	1000	2000	3500
Up to 60 °C	A	1710	1000	1950	3250
Up to 70 °C	A				
Power loss at I_n for symmetrical loads					
Withdrawable circuit breakers	W	150	280	770	1640
Switching times					
• Make time	ms	35	35	35	35
• Opening time	ms	38	34	34	34
• Electrical make time (through activation solenoid) ¹⁾	ms	100	100	100	100
• Electrical opening time (through shunt release)	ms	73	73	73	73
• Electrical opening time (instantaneous undervoltage release)	ms	73	73	73	73
Endurance³⁾					
• Mechanical (without maintenance)	Operating cycles	10 000	10 000	10 000	10 000
• Mechanical (with maintenance) ²⁾	Operating cycles	15 000	15 000	15 000	15 000
• Electrical (without maintenance)	Operating cycles	1 000	6 000	6 000	4 000
• 1000 V version	Operating cycles	1 000	1 000	1 000	1 000
• Electrical (with maintenance) ²⁾	Operating cycles	2 000	15 000	15 000	15 000
Switching frequency					
• 600 V version	1/h	--	60	60	60
• 1000 V version	1/h	20	20	20	20
Mounting position					
Degree of protection		IP20 without cabinet door, IP41 with door sealing frame, IP55 with cover			
Auxiliary conductors (Cu)	Standard connection = strain-relief clamp				
Max. number	• Without end sleeve	2 × 0.5 mm ² (AWG 20) ... 2 × 1.5 mm ² (AWG 16); 1 × 2.5 mm ² (AWG 14)			
Auxiliary conductors × cross-section (solid/stranded)	• With end sleeve acc. to DIN 46228 Part 2	1 × 0.5 mm ² (AWG 20) ... 1 × 1.5 mm ² (AWG 16)			
	• With twin end sleeve	2 × 0.5 mm ² (AWG 20) ... 2 × 1.5 mm ² (AWG 16)			
	Optional connection = tension spring				
	• Without end sleeve	2 × 0.5 mm ² (AWG 20) ... 2 × 2.5 mm ² (AWG 14)			
	• With end sleeve acc. to DIN 46228 Part 2	2 × 0.5 mm ² (AWG 20) ... 2 × 1.5 mm ² (AWG 16)			
Weights					
3-pole	• Fixed-mounted circuit breakers	kg 43	56	56	64
	• Withdrawable circuit breakers	kg --	60	60	68
	• Guide frames	kg --	31	31	45
4-pole	• Fixed-mounted circuit breakers	kg 50	67	67	77
	• Withdrawable circuit breakers	kg --	72	72	82
	• Guide frames	kg --	37	37	54

¹⁾ Make-time through activation solenoid for synchronization purposes (short-time excited) 50 ms.

²⁾ Maintenance means: replace main contact elements and arc chutes (see Operating Manual).

³⁾ Further technical specifications on request.

Size		I	II	
Type		3WL11	3WL12	
Breaking capacity		DC	DC	
Rated short-circuit breaking capacity				
Up to 220 V DC	I_{cc}	kA 20	35	
Up to 300 V DC	I_{cc}	kA 20	30	
Up to 600 V DC	I_{cc}	kA 20	25	
Up to 1000 V DC	I_{cc}	kA 20	20	
Rated short-time withstand current I_{cw}				
0.5 s	kA	--	--	
1 s	kA	20	35 ¹⁾ /30 ²⁾ /25 ³⁾ /20 ⁴⁾	
2 s	kA	--	--	
3 s	kA	--	--	

¹⁾ At $U_e = 220$ V DC.

²⁾ At $U_e = 300$ V DC.

³⁾ At $U_e = 600$ V DC.

⁴⁾ At $U_e = 1000$ V DC.

3WL Air Circuit Breakers

3WL non-automatic air circuit breakers up to 4000 A (DC)

Project planning aids

Characteristic curves

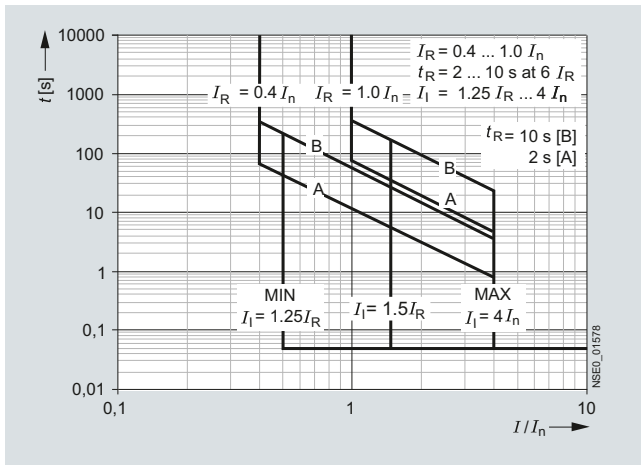

DIGmat S100 characteristic curve

Dimensional drawings

DIGmat S100

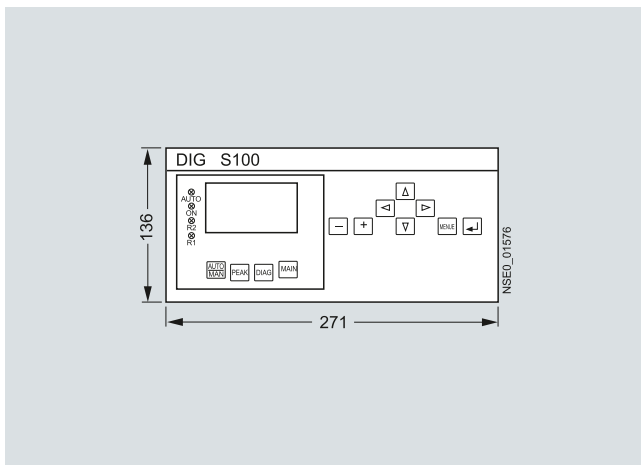

DIGmat S100

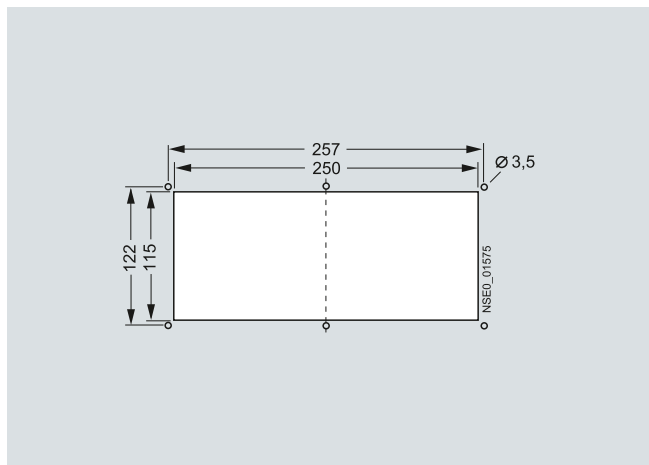

DIGmat S100 drilling pattern

3WL Air Circuit Breakers

3WL non-automatic air circuit breakers up to 4000 A (DC)

Project planning aids

Size II, up to 4000 A, fixed-mounted version, 3- and 4-pole

Standard version

Horizontal connection

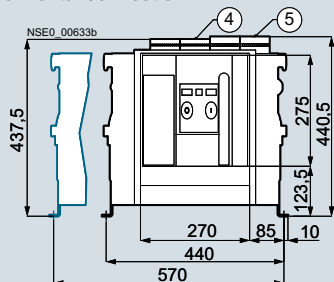

Optional connection variants

Front connection (single)

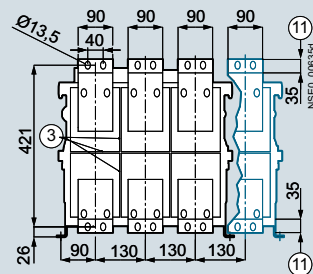

Front connection (double hole)

according to DIN 43673

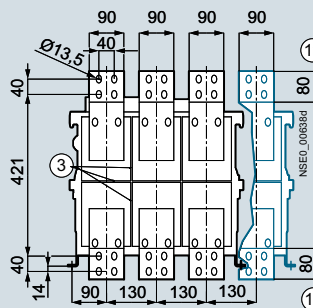
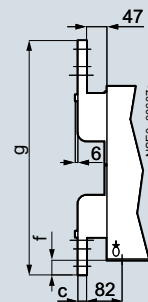
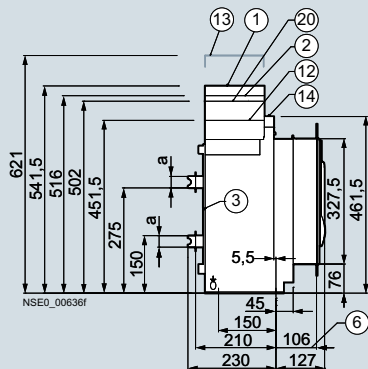

Vertical connection

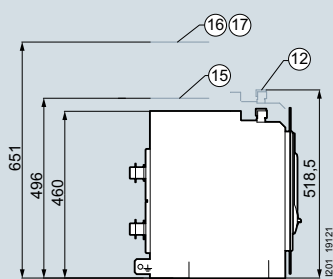
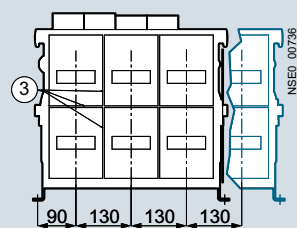
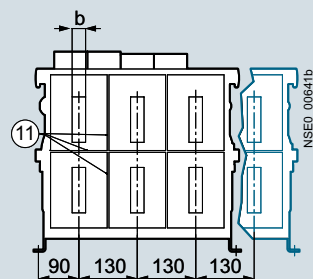
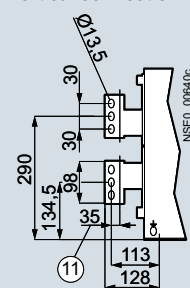
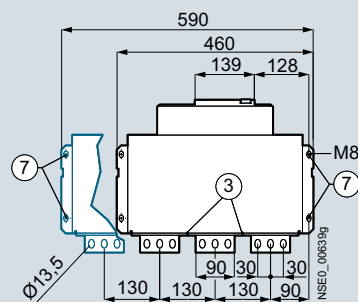

General

Rated circuit breaker current	a	b	c	d	e	f	g
A							
Up to 2000	10	15	10	11	451	34	541
4000	30	30	20	6	461	39	551

Blue lines: 4-pole version

- ① Mounting space for removal of the arc chutes
- ② Arc quenching space, space for electrical auxiliary circuit connections
- ③ Grooves (4 mm wide, 5 mm deep) for supporting phase partitions in the system
- ④ Auxiliary connector with SIGUT screw terminals
- ⑤ Auxiliary connector with spring-type connections
- ⑥ Dimension to inside surface of the closed cabinet door
- ⑦ Fixing points for mounting the circuit breaker in the system
- ⑩ Terminal face
- ⑫ Circuit breaker upper edge, only 1000 V, 1150 V and circuit breakers with breaking capacity class C, 3WL1 circuit breaker only
- ⑬ Arc quenching space, 1000 V circuit breaker facing grounded or non-conductive surfaces
- ⑭ Space for electrical auxiliary circuit connections

- ⑮ Arc quenching space, 300 V circuit breaker facing grounded or non-conductive surfaces
- ⑯ Arc quenching space, 600 V circuit breaker facing grounded or non-conductive surfaces
- ⑰ Circuit breaker upper edge, only 1000 V, 1150 V and circuit breakers with breaking capacity class C

Safety clearances to grounded parts and to live parts, see page 41.

3WL Air Circuit Breakers

3WL non-automatic air circuit breakers up to 4000 A (DC)

Project planning aids

Size II, up to 4000 A, withdrawable version, 3- and 4-pole

Standard version

Horizontal connection

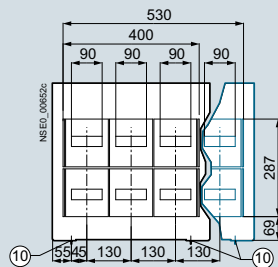
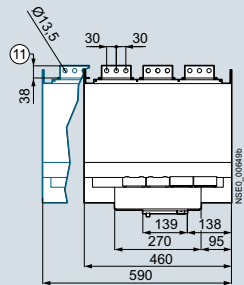
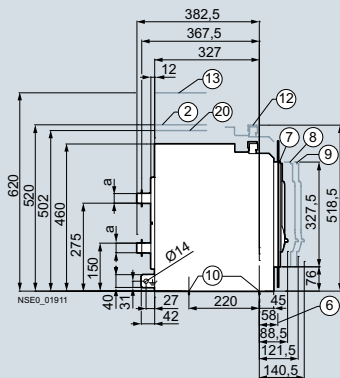
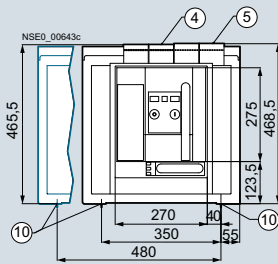

Optional connection variants Vertical connection up to 3000 A

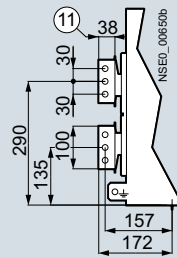

Flange connection

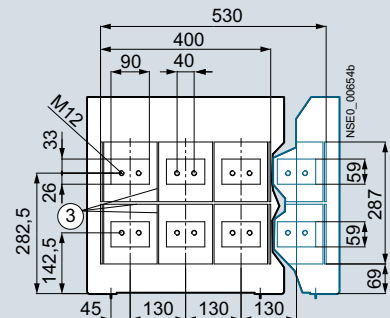
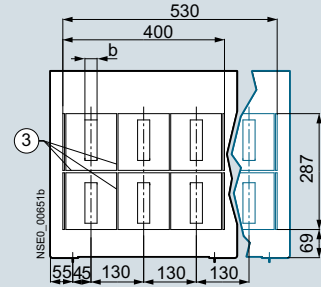
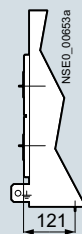

Front connection (single)

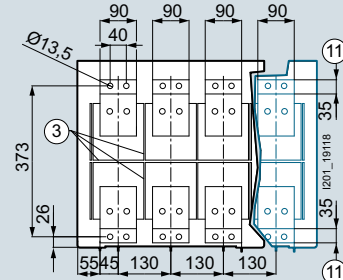
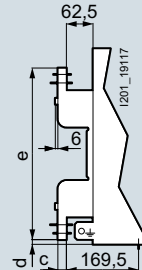

Front connection (double hole) according to DIN 43673

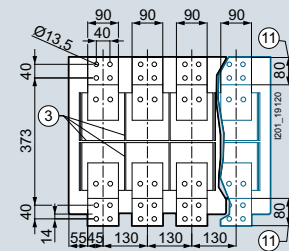
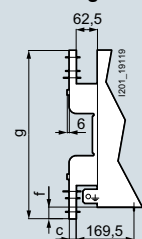

Blue lines: 4-pole version

③ Grooves (4 mm wide, 5 mm deep) for supporting phase partitions in the system

④ Auxiliary connector with SIGUT screw terminals

⑤ Auxiliary connector with spring-type connections

⑥ Dimension to inside surface of the closed cabinet door

⑦ 3WL in operating position

⑧ 3WL in test position

⑨ 3WL in disconnected position

⑩ Fixing holes, diameter 9 mm

⑪ Terminal face

⑫ Guide frame upper edge – 1000 V version only

⑬ Arc quenching space, 300 V circuit breaker facing grounded or non-conductive surfaces

⑭ Arc quenching space, 600 V circuit breaker facing grounded or non-conductive surfaces

⑮ Arc quenching space, 1000 V circuit breaker (with high arc chute) facing grounded or non-conductive surfaces

Rated circuit breaker current (A)	a	b	c	d	e	f	g
Up to 2000	10	15	10	11	403	34	493
4000	30	30	20	6	413	39	503

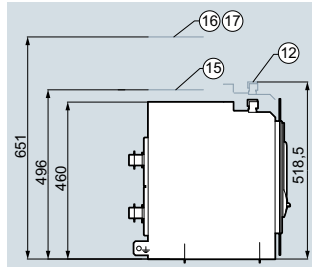

Safety clearances to grounded parts and to live parts, see page 41.

3WL Air Circuit Breakers

3WL non-automatic air circuit breakers up to 4000 A (DC)

Project planning aids

Circuit diagrams

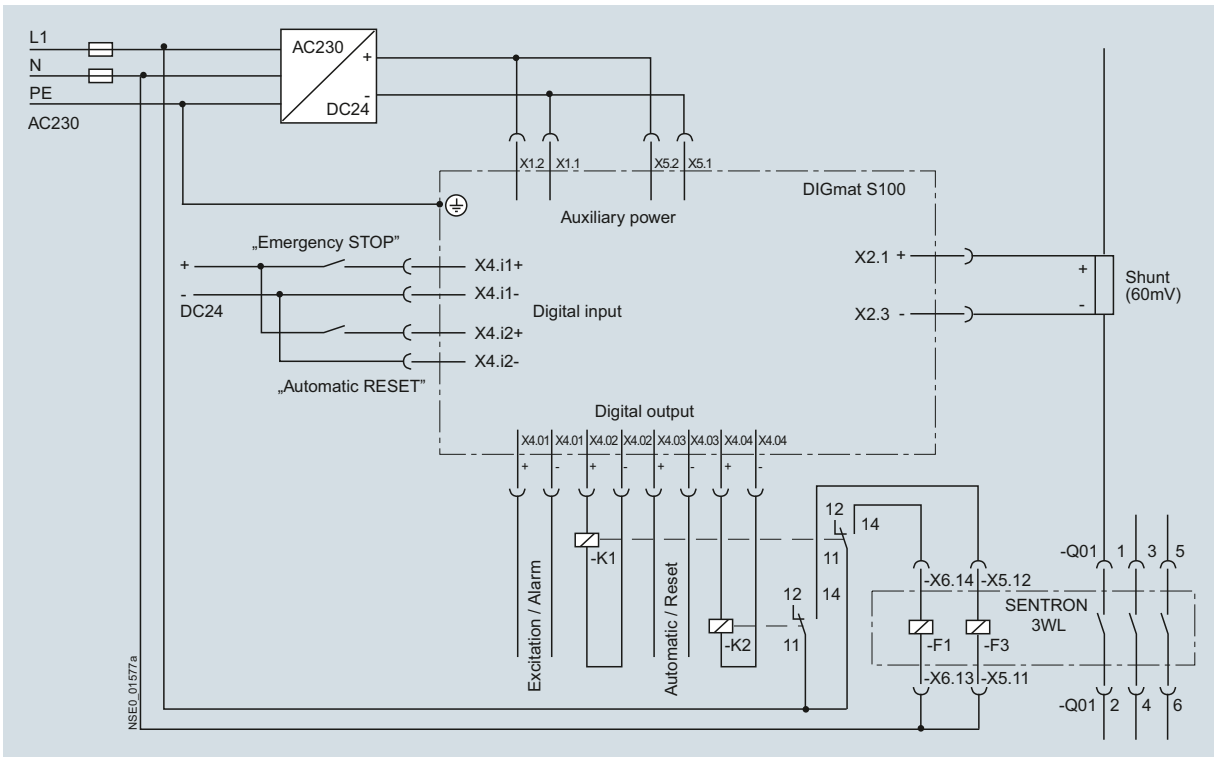

Circuit diagrams of the DIGmat S100 and the 3WL non-automatic air circuit breaker

Application examples

Rated operational voltage	Required series-connected contact gaps at rated voltage	For 3-pole non-automatic air circuit breakers (operational currents up to 4000 A/ conducting path)	For 4-pole non-automatic air circuit breakers (operational currents up to 4000 A/ conducting path)
Up to 300 V + 10 %		 NSS0_00539 1-pole, 2 parallel conducting paths, only with grounded system	 2-pole
Over 300 V + 10 % Up to 600 V + 10 %		 1-pole, 3 parallel conducting paths, only with grounded system	 2-pole, 2 parallel conducting paths
Over 600 V + 10 % Up to 1000 V + 10 % (version for 1000 V re- quired, order with "-Z" and order code A05)		 1-pole, 2 parallel conducting paths, only with grounded system	 2-pole, 1 parallel conducting path, only with grounded system

The connection to the circuit breakers is not dependent on direction and polarity; the circuit diagrams can be adapted accordingly.

If the parallel or series connections are made directly to the connecting bars, for thermal reasons the continuous load on the circuit breakers must only be 80 % of the permissible operational

current. If the parallel or series connection is made at a distance of 1 m from the connecting bars, the circuit breaker can be used at full operational current load.

- |⊥| Grounded system
- ▣ Load

More information

Up-to-date information on the Internet at:

www.siemens.com/sentron

3WL Air Circuit Breakers

3WL non-automatic air circuit breakers up to 4000 A (DC)

Notes

Siemens AG
Energy Management
Low Voltage & Products
Postfach 10 09 53
93009 REGENSBURG
GERMANY

Subject to change without prior notice
PDF (3ZW1012-3WL11-0AC1)
PH 0115 60 En
Produced in Germany
© Siemens AG 2015

The information provided in this configuration manual contains merely general descriptions or characteristics of performance which in case of actual use do not always apply as described or which may change as a result of further development of the products. An obligation to provide the respective characteristics shall only exist if expressly agreed in the terms of contract. Availability and technical specifications are subject to change without notice.
All product designations may be trademarks or product names of Siemens AG or supplier companies whose use by third parties for their own purposes could violate the rights of the owners.