

DISTRIBUTION TRANSFORMERS

OIL IMMERSED up to 6 MVA





PARTNERSHIP

SAFETY

DURABILITY

Contents

1	- General Information	4
2	- Applications	10
3	- Product Portfolio	11
4	- Product Breakdown	12
5	- Transformer Classifications	13
	A - Standard Losses Transformers.....	14
	B - High Efficiency Transformers.....	16
	C - Utility Transformer (SEC).....	17
	1 - Pad Mounted Transformers.....	17
	2 - Pole Mounted Transformers.....	19
	3 - Unit Substation.....	21
	D-Special Transformers.....	23
	1 - LV/LV Transformers.....	23
	2 - MV/MV Transformers.....	24
	3 - Dual Voltage Transformers.....	25
	• On Low Voltage.....	26
	• On Medium Voltage.....	26
	4 - Non-Mineral Oil Transformers (KNAN).....	27
6	- Accessories	28
	• Standard Accessories.....	29
	1. Bushing.....	29
	2. Cable Box.....	33
	3. Oil Level Indicator.....	33
	4. Thermometer.....	33
	5. Pressure Relief Valve.....	33
	6. Earthing Terminal on Tank.....	34
	7. Drain Valve.....	34
	8. Tap Changer.....	34
	9. Lifting Lugs.....	34
	• Optional Accessories.....	35
	1. DMCR.....	35
	2. Oil Conservator.....	35
	3. Buchholz Relay.....	35
	4. Air Breather.....	35
	5. Roller.....	35
	6. Winding Temperature Indicator.....	35
7	- Package and Unit Substation	36
	• Design and Structure.....	36
	– Ring Main Unit.....	37
	– Transformer.....	39
	– Low Voltage Panel.....	40
	• Technical Features.....	41
8	- Service	42
9	- Testing	43
10	- Inquiry Form	44

1 – General Information

A – Standards

The IEC and BS standards for transformers and their parts are the most widely applied standards in most countries where local electric authorities have either adopted one of these standards or created one that suits the needs, laws and regulations of their country.

The following list of main Standards refers to the most common electrical applications.

The Standards may have been amended, but the relevant amendments are not mentioned here.



IEC 60076 Power Transformers

IEC 62271-200 AC metal-enclosed switchgear and controlgear for rated voltage above 1 kV and up to and including 52 kV

IEC 62271-202 High-voltage/low-voltage prefabricated substation

IEC 62271-100 High-voltage alternating-current circuit breakers

IEC 62271-102 Alternating current disconnectors(isolators) and earthing switch

IEC 62271-105 High-voltage switchgear and controlgear alternating current switch-fuse combination

IEC 60296 Unused mineral insulating oils for transformers and switchgear

IEC 60137 Insulated bushings for alternating voltages above 1000 V

IEC 60529 Classification of degree of protection provided by enclosures

B – Cooling Code and Insulation Liquid

No transformer is truly an ‘ideal transformer’ as each will incur some losses which gets converted into heat. If this heat is not dissipated properly, the excess temperature in the transformer has the potential to cause serious problems like insulation failure. The transformer requires a cooling system to prevent this from occurring.

- For Oil Immersed Transformers
 - ONAN: Oil Natural Air Natural
 - ONAF: Oil Natural Air Forced

The ONAN transformers can be operated with normal rating and ONAF with an increased rating of approximately 25%.

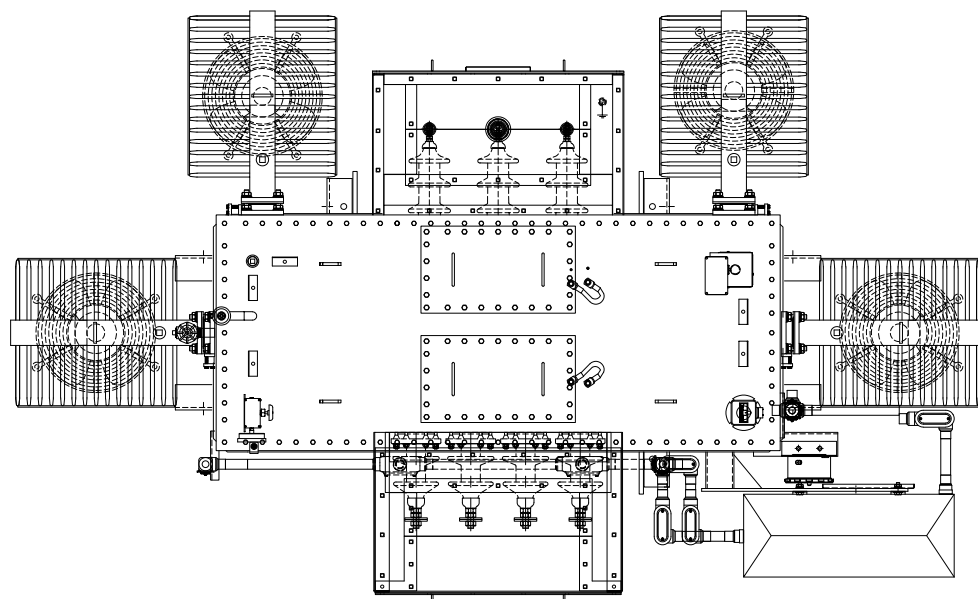

C - Technical Aspects

• Power Rating and Voltage Levels

A power rating is the rated voltage (multiplied by the phase-factor for three-phase transformers) and the rated line current at center tap when several taps are provided.



Power rating is expressed in kVA or MVA.

The rated power of the three-phase transformer is defined by the formula:

$$P = V * I * 1.73$$

“V” is the rated line to line voltage,

“I” is the rated line current of the transformer

“1.73” is the numerical value for the square root of 3.

Transformers are energized usually from a network which has a defined voltage level which is the primary (feed) voltage level. Transformers should transform the primary voltage to a new voltage, the secondary voltage level, that is required by the consumer.

Transformers can be designed to operate with two primary voltages (one at a time), therefore, if the network voltage must be changed in the future, the same unit will be used.

Transformers can be designed to generate two secondary voltages simultaneously, thus, outputting two levels for two applications.

The primary and secondary voltages define a Basic Insulation Level (BIL) of 75, 95, 110, 125, 170 and 200kV. The transformer is designed accordingly for electrical withstand of over-voltages.

1 – General Information

- **Altitude**

The transformers are suitable for operation at altitudes of up to 1000m above sea level. Site altitudes above 1000m require the use of special designs and should be mentioned in the order.



- **Short Circuit Impedance**

The short circuit impedance is the transformer's impedance, usually between 4% and 6% for distribution transformers and higher than 7% for power transformers. The short circuit impedance is the percentage of the primary rated voltage that must be applied at the transformer primary winding when the secondary winding is shorted in order to have the rated currents in the primary and secondary windings. If the short circuit impedance increases, it will result in an unnecessary voltage drop across the power transformer and will limit its ability to deliver power to the secondary-connected equipment.

- Transformers working in parallel should have identical short circuit impedance

- **Vector Group**

The vector group is the International Electrotechnical Commission (IEC) method of categorizing the high voltage (HV) windings and low voltage (LV) winding configurations of three-phase transformers. The vector group designation indicates the windings configurations and the difference in phase angle between them.

The possible connections are as follows:

- D (d) delta connection
- Y (y) star connection
- Z (z) zigzag connection
- N (n) the neutral exists for connection outside the transformer

The Vector Group determines the phase displacement between the primary and the secondary winding, and each unit in the vector group refers to 30 degrees displacement. A vector group Dyn11 is delta on primary, star on secondary, with neutral brought out and 330-degree phase displacement.

• Tank Types

The transformer tank is usually a non-rigid structure with corrugated panels, designed to withstand the mechanical stresses, absorb the oil expansion, and meet the thermal evacuation constraints.

For power rating above 3150kVA, the tank is usually designed with rigid structure, cooling radiators and conservator.



• Magnetic Circuits

The types of magnetic circuit are:

- Three legs construction
- Step lap stacking

Made from a cold rolled, grain oriented silicon steel strips, each strip (0.23, 0.27 or 0.30mm thick) is insulated on both sides by Carlite.



• Permissible Tolerances

Manufacturing tolerances are the deviations between the measured values and the guaranteed values. Unless otherwise specified in the order, the tolerances are limited to the values specified in IEC 60076-1.

1 - General Information

- **Frequency**

Frequency is the number of occurrences of a repeating event per unit of time. It is also referred to as temporal frequency, which emphasizes the contrast to spatial frequency and angular frequency. The period is the duration of time of one cycle in a repeating event, so the period is the reciprocal of the frequency.

The frequency at which the transformer is designed to operate is 50Hz or 60Hz and is set in accordance with the network frequency.



- **Ambient Temperature and Temperature Rise**

The normal ambient temperature under which the transformer will operate is defined as the Ambient temperature, where the temperature rise expresses the rise of the cooling medium and the winding temperatures when the transformer operates at full load. The maximum values are defined by applied standards.

• Winding Coils

An electromagnetic coil is an electrical conductor such as a wire in the shape of a coil, spiral or helix used in applications where electric currents interact with magnetic fields. Either an electric current is passed through the wire of the coil to generate a magnetic field, or conversely an external time-varying magnetic field through the interior of the coil generates an EMF (voltage) in the conductor.



Both the primary and secondary windings are made of copper or aluminum. The primary voltage is directly wound on the secondary voltage winding, with insulating barriers and cooling channels between the two windings. Secondary voltage coils are rectangular wires or foil conductors. Primary voltage coils are round enamel wires, or rectangular paper insulated wires for high power ratings, or paper insulated round wires.

Adequate channels for oil circulation are integrated in the windings to provide efficient cooling and to limit the hot spot temperature.

2 - Applications

The distribution transformer provides the final voltage transformation in the electric power distribution system, stepping down the networks medium voltage to low voltage, the level used by the consumer, and is considered one of the most important links in the distribution network.

Distribution transformers are used in the following applications:



3 – Product Portfolio

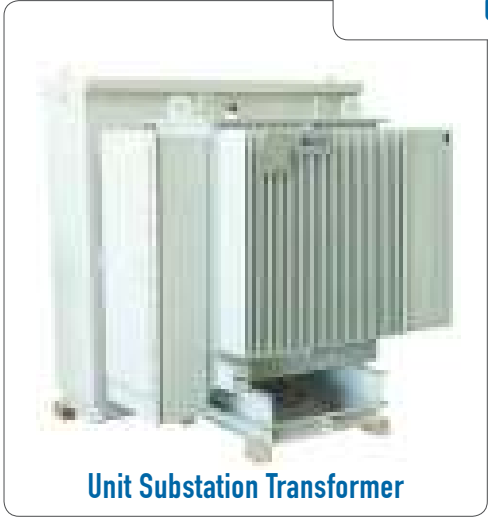

4 - Product Breakdown

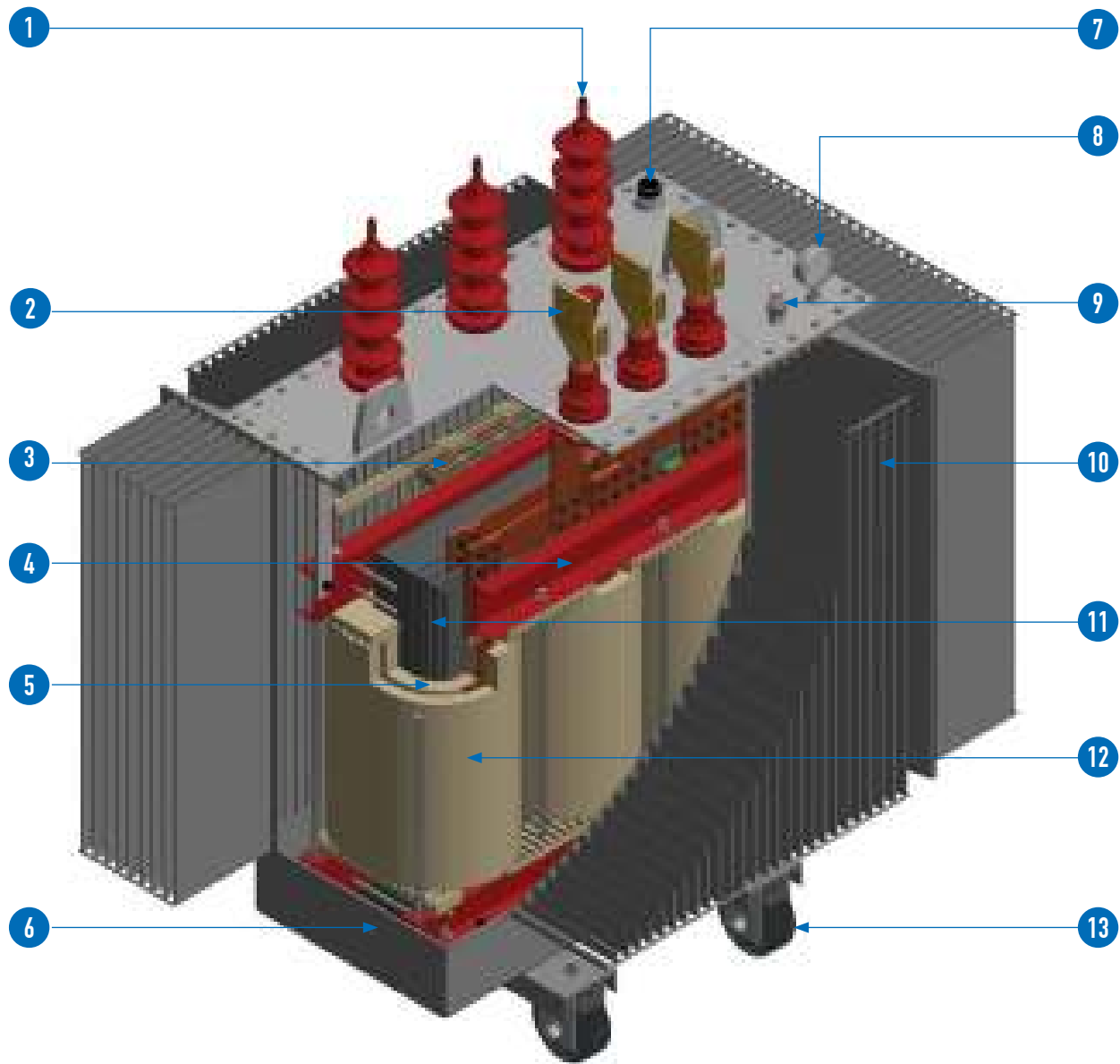

- | | |
|-----------------------|-------------------------|
| 1 HV Bushing | 7 Pressure Relief Valve |
| 2 LV Bushing | 8 Top Oil Thermometer |
| 3 No Load Tap Changer | 9 Oil Level Indicator |
| 4 Core Clamps | 10 Corrugated Fins |
| 5 LV Coil | 11 Core |
| 6 Transformer Tank | 12 HV Coil |
| | 13 Roller |

5 - Transformer Classifications

A distribution transformer or service transformer is a transformer that provides the final voltage transformation in the electric power distribution system, stepping down the voltage used in the distribution lines to the level used by the customer.

Whether the transformers are used for infrastructure systems, industry or households, **alfanar** provides the right transformer for every need – from compact distribution transformers to limited power transformers with ratings up to 6000 kVA.

Transformers can be classified based on many factors like installation or losses which is the most important factor in the transformer.

In any electrical machine, 'loss' can be defined as the difference between input power and output power.



A – Standard Losses Transformer



As per the international standards, and especially the IEC, each transformer's manufacturer should respect the losses limits and references in order to be acceptable.

Under those values a standard losses transformer is made to fulfil the customer requirements with a competitive cost and high quality.

Common Data	Three Phase, Oil Immersed Distribution Transformers (Indoor or Outdoor Installation)		
Standard	-	IEC60076	
Rated Frequency		Hz	60 or 50
Connection and Vector Group	-	Dyn11*	
Max. Temperature Rise	Top Oil	°C	50*
Average Winding		°C	55*
Type of Cooling		-	ONAN
Rated Primary Voltage	As per customer's request	kV	Up to 36 kV
Rated Secondary Voltage	As per customer's request	kV	Up to 13.8 kV
HV Tapping	Off-circuit tap changer 5 positions	%	± 2x2.5
Winding		-	Copper or Aluminum Conductors
Losses		-	As per standard

* Subject to change according to customer requirements

• Technical Specification of Standard Transformer (13.8/0.4kV)

Rated Power (kVA)	HV Taps (%)	Vector Group	Voltage Impedance (%)	As per IEC Specification		As per SEC Specification 51-SDMS-02	
				No Load Losses (W)	Load Losses at 75°C (W)	No Load Losses (W)	Load Losses at 75°C (W)
50	± 5%	Dyn11	4	210	1100	-	-
100	± 5%	Dyn11	4	300	2150	250	1500
200	± 5%	Dyn11	4	480	2950	380	2200
300	± 5%	Dyn11	4	630	4200	520	3200
500	± 5%	Dyn11	5	850	6000	750	4700
750	± 5%	Dyn11	6	1100	10100	-	-
1000	± 5%	Dyn11	6	1450	12000	1100	9000
1250	± 5%	Dyn11	6	1700	13000	-	-
1500	± 5%	Dyn11	6	1850	16500	1700	14000
2000	± 5%	Dyn11	6	2800	19500	-	-
2500	± 5%	Dyn11	6.5	3000	25500	-	-
3000	± 5%	Dyn11	7	3000	28500	-	-
3150	± 5%	Dyn11	7	3300	30000	-	-

B - High Efficiency Transformer



alfanar High Efficiency Transformers offer the best ratio between initial cost and operating cost for sensitive applications.

Lowering the energy consumption results in reduced operating costs and less harmful emissions for the customer's operations.

Common Data	Three Phase, Oil Immersed Distribution Transformers (Indoor or Outdoor Installation)		
Standard	-		IEC60076
Rated Frequency		Hz	60 or 50
Connection and Vector Group	-		Dyn11*
Max. Temperature Rise	Top Oil	°C	50*
	Average Winding	°C	55*
Type of Cooling	-		ONAN
Rated Primary Voltage	As per customer's request	kV	Up to 36 kV
Rated Secondary Voltage	As per customer's request	kV	Up to 13.8 kV
HV Tapping	Off-circuit tap changer 5 positions	%	± 2x2.5
Winding	-		Copper or Aluminum Conductors
Primary Insulation Level			LI 75 / AC 28 / Um 12
			LI 95 / AC 38 / Um 17.5
			LI 125 / AC 50 / Um 24
			LI 170 / AC 70 / Um 36
Losses	-		As per ECO design (Ao, Ak), Refer to EN (50464-1)

* Subject to change according to customer requirements

C – Utility Transformer “SEC”



1-Pad Mounted Transformers

alfanar three-phase pad-mounted transformers are compact power centers that can be used for all types of applications.

With a proper design selection, they can be located near or inside buildings for greater flexibility and savings, and are designed to withstand environmental hazards.

The transformers are designed to meet or exceed applicable local and international standards such as IEC and BS standards.

All transformers are manufactured and are produced expressly to meet a customer’s exacting specifications.

• Technical Data

Transformer Type	Pad Mounted	
Type of Breathing	Hermetically Sealed	
Standard	IEC60076 & SEC	
Rated Frequency	60 Hz	
Connection and Vector Group	Dyn11*	
Ambient Temperature	55°C	
	Top Oil	45°C
	Average Winding	50°C
Winding	Copper or Aluminum Conductors	
Type of Cooling	ONAN	
HV Tapping	Off-circuit tap changer 5 positions	± 2×2.5 *%

* Subject to change according to customer requirements

Rated Power kVA	HV V	LV V	No Load Loss W	Load Loss W	Impedance %	Width mm	Depth mm	Height mm
300	13.8	0.4	520	3200	4	1700	1400	1600
500	13.8	0.4	750	4700	5	1700	1400	1600
1000	13.8	0.4	1100	9000	6	1900	1600	1900
1500	13.8	0.4	1700	14000	6	1920	1700	2000
300	33	0.4	520	3200	4	1700	1400	1600
500	33	0.4	750	4700	5	1700	1400	1600
1000	33	0.4	1100	9000	6	1900	1600	1900
1500	33	0.4	1700	14000	6	1920	1700	2000

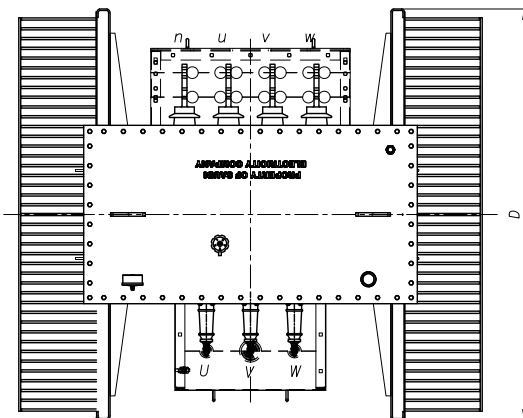
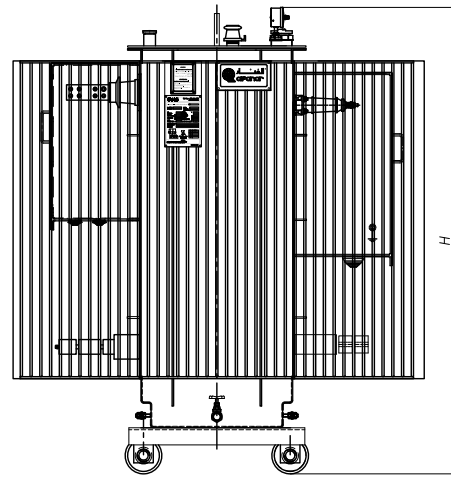
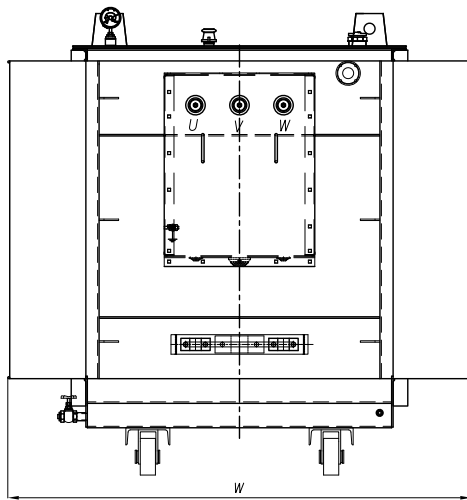

C – Utility Transformer “SEC”



2 - Pole Mounted Transformers

Pole mounted transformers are electric utility distribution transformers that are mounted on an electrical service pole (wood or concrete) and are usually at the level of the overhead cables.

These transformers typically service urban and rural residential and commercial loads. Other uses include light industrial and commercial lighting applications.

• Technical Data

Transformer Type	Pole Mounted	
Type of Breathing	Hermetically Sealed	
Standard	IEC60076 & SEC	
Rated Frequency	60 Hz	
Connection and Vector Group	Dyn11*	
Ambient Temperature	55°C	
	Top Oil	45°C
	Average Winding	50°C
Winding	Copper or Aluminum Conductors	
Type of Cooling	ONAN	
HV Tapping	Off-circuit tap changer 5 positions	± 2×2.5 *%

* Subject to change according to customer requirements

Rated Power kVA	HV V	LV V	No Load Loss W	Load Loss W	Impedance %	Width mm	Depth mm	Height mm
100	13.8	0.4	250	1500	4	1350	900	1450
200	13.8	0.4	380	2200	4	1450	1100	1700
300	13.8	0.4	520	3200	4	1450	1100	1700

Rated Power kVA	HV V	LV V	No Load Loss W	Load Loss W	Impedance %	Width mm	Depth mm	Height mm
100	33	0.4	250	1500	4	1350	900	1450
200	33	0.4	380	2200	4	1450	1100	1700
300	33	0.4	520	3200	4	1450	1100	1700

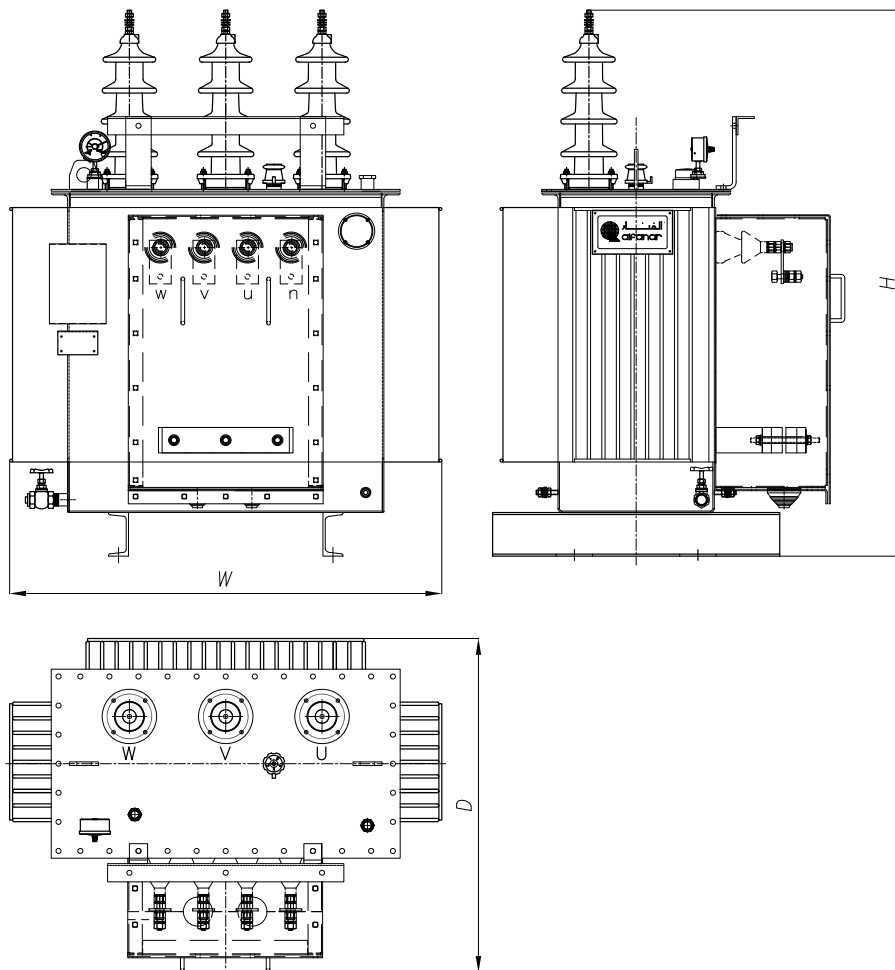

C – Utility Transformer “SEC”



3 - Unit Substation

The unit substation transformer is designed for commercial and industrial applications to convert distribution voltages to utilization voltages. They are constructed to interconnect easily with both primary and secondary switchgear.

Unit substations follow the system concept of locating transformers as close as practical to areas of load concentration at utilization voltages to minimize the lengths of secondary distribution cables and buses.

Unit Substations are a compact solution for multiple functions, and can be used in either indoor or outdoor applications.

General		
Related Specification	56-SDMS-07	USS With aluminum transformer & aluminum busbars LVDP
	56-SDMS-01	USS With copper transformer & copper Busbars LVDP
Ambient temperature		Up to 55 C
outdoor color		RAL 7035 or RAL 7033
Location of operation		Out door
Degree of protection		up to IP 54
Electrical Characteristics		
Nominal Unit S/S rating	kVA	300 , 500 ,1000 ,1500
MV Rating	kV	13.8 kV, 33 kV, 34.5-33kV (dual)
LV Rating	V	400V , 230V , 400-230V(dual)
Rated Frequency	Hz	60
Transformer		
Rated transformer	kVA	up to 1500
Vector Group		Dyn11
Low Voltage Board		
Main Incomer	A	up to 4000 A
Metering devices		Digital
Busbar		Tin plated Aluminum / Copper Busbar
L.V Panel Distribution Units		Branch MCCB/ Main Breaker

Max Dimensions (Aluminum)

kVA	300	500	1000	1500
Length (mm)	1800	1800	2200	2400
Width (mm)	1500	1500	1500	1800
Height(mm)	2200	2200	2200	2200

Max Dimensions (Copper)

kVA	300	500	1000	1500
Length (mm)	1800	1800	2000	2400
Width (mm)	1500	1500	1500	1800
Height(mm)	2200	2200	2200	2200

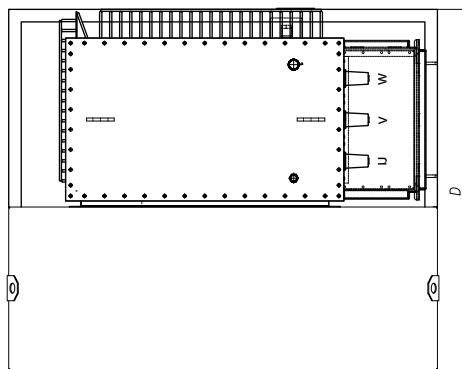
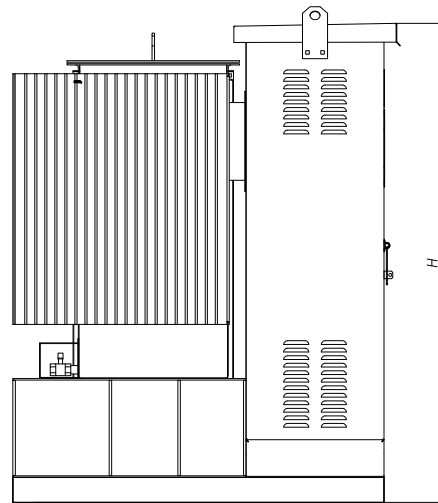
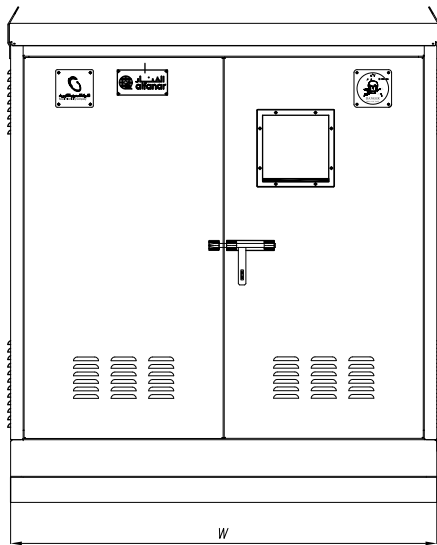

D – Special Transformer

To service a wide range of loads and market demands, **alfanar** can provide a broad spectrum of the special transformers of high quality and compact design to meet these needs.

1 - LV/LV Transformers

LV/LV transformers are generally in the range of hundreds of kVA and are frequently used for:

- Changing the low voltage level for:
 - **Auxiliary supplies to control and indication circuits**
 - **Lighting circuits (230 V created when the primary system is 400 V 3-phase 3-wires)**
- Changing the method of earthing for certain loads having a relatively high capacitive current to earth (computer equipment) or resistive leakage current (electric ovens, industrial-heating processes, mass-cooking installations, etc.).



Common Data	Three Phase, Oil Immersed Distribution Transformers (Indoor or Outdoor Installation)		
Standard	-		IEC60076
Rated Frequency		Hz	60 or 50
Connection and Vector Group	-		Dyn11*
Max. Temperature Rise	Top Oil	°C	50*
	Average Winding	°C	55*
Type of Cooling		-	ONAN
Rated Primary Voltage	As per customer's request	kV	Up to 1 KV
Rated Secondary Voltage	As per customer's request	kV	Up to 1 KV
Winding	Copper or Aluminum Conductors		
Losses		-	As per Standards

* Subject to change according to customer requirements

2 - MV/MV Transformers

MV/MV transformers are manufactured according to customer request in order to meet the technical features of the plant where they will be installed. **alfanar** provides technical engineering support from the preliminary studies of the transformer to assist the customer in the specification selection.



Common Data	Three phase, Oil Immersed Distribution Transformers (Indoor or Outdoor Installation)		
Standard	-		IEC60076
Rated Frequency		Hz	60 or 50
Connection and Vector Group	-		Dyn11*
Max. Temperature Rise	Top Oil	°C	50*
	Average Winding	°C	55*
Type of Cooling		-	ONAN
Rated Primary Voltage	As per customer's request	kV	Up to 36 kV
Rated Secondary Voltage	As per customer's request	kV	Up to 36 kV
HV Tapping	Off-circuit tap changer 5 positions	%	± 2x2.5
Winding		-	Copper or Aluminum Conductors
Primary Insulation Level			LI 75 / AC 28 / Um 12
			LI 95 / AC 38 / Um 17.5
			LI 125 / AC 50 / Um 24
			LI 170 / AC 70 / Um 36
Losses		-	As per Standards

* Subject to change according to customer requirements

3 - Dual Voltage Transformers



A Dual Voltage Transformer can be defined as the one capable of providing two types of voltages, i.e. if the two separate windings are connected in series, they will provide the sum of voltages supplied to the two coils and if the two windings are connected in parallel, then the net voltage will be decreased. These voltages can be switched within the transformer according to the type of output required by using a dual voltage switch.

Using a transformer which has reconnectable windings greatly reduces costs and saves time as many power applications require a number of voltage levels for different machines, in this case using different types of transformers is not a solution.

1 - On Low Voltage

Common Data	Three phase, Oil Immersed Distribution Transformers (Indoor or Outdoor Installation)		
Standard	-	IEC60076	
Rated Frequency		Hz	60 or 50
Connection and Vector Group	-		Dyn11*
Max. Temperature Rise	Top Oil	°C	50*
	Average Winding	°C	55*
Type of Cooling		-	ONAN
Rated Primary Voltage	As per customer's request	kV	Up to 36 kV
Rated Secondary Voltage	As per customer's request	V	500-400 or 480-400 or 400-231, etc*
HV Tapping	Off-circuit tap changer 5 positions	%	± 2x2.5
Winding		-	Copper or Aluminum Conductors
Primary insulation level	LI 75 / AC 28 / Um 12		
	LI 95 / AC 38 / Um 17.5		
	LI 125 / AC 50 / Um 24		
	LI 170 / AC 70 / Um 36		
Losses		-	As per Standards

* Subject to change according to customer requirements

2 - On Medium Voltage

Common Data	Three phase, Oil Immersed Distribution Transformers (Indoor or Outdoor Installation)		
Standard	-	IEC60076	
Rated Frequency		Hz	60 or 50
Connection and Vector Group	-		Dyn11*
Max. Temperature Rise	Top Oil	°C	50*
	Average Winding	°C	55*
Type of Cooling		-	ONAN
Rated Primary Voltage	As per customer's request	kV	22/11 or 13.8-11 or 11-6.6 , etc
Rated Secondary Voltage	As per customer's request	kV	Up to 1 kV
HV Tapping	Off-circuit tap changer 5 positions	%	± 2x2.5
Winding		-	Copper or Aluminum Conductors
Primary Insulation Level	LI 75 / AC 28 / Um 12		
	LI 95 / AC 38 / Um 17.5		
	LI 125 / AC 50 / Um 24		
	LI 170 / AC 70 / Um 36		
Losses		-	As per Standards

* Subject to change according to customer requirements

4- Non-Mineral Oil Transformers (KNAN)



The designation of cooling types of oil distribution transformers depends on the fire point of the oil being used in the transformer. Mineral oils are symbolized with “O” with minimum flash point 135°C as per IEC 60296- Ed. 4, 2012. Non-mineral oils such as silicone oil, Synthetic Ester (which is also known in the market by the brand “Midel”) and Natural Ester (vegetable oils) are designated with “K” since their fire point is above 300°C.

Each letter in KNAN transformer cooling stands for:

K - indicates a beyond 300-degree Celsius fire point

N - denotes Natural

A - is equal to Air

N - Natural

- 100% fire safety record
- High fire point >300°C
- Classified as K-class
- Renowned resistance to ignition
- Midel doesn't contribute to the fire
- Self-extinguishing (Fire extinguished in 7.5 Seconds)
- No risk of pool fires

• alfanar Silicon Oil or Midel Oil Transformers

The silicon oil transformer is characterized by its high dielectric strength, high flash point, wide service temperature range, low vapor pressure, good heat capacity values, low pour point, low viscosity change at extremely high and low temperatures, and inertness to virtually all substrates.



Features

- High dielectric strength fluid
- High fire point > 300° minimal flammability and high temperature stability
- Low viscosity change, low volatility
- High thermal oxidation resistance
- Chemically inert
- Low toxicity
- Compatible with most existing transformer insulation systems
- Longer service life than conventional transformer oils

6 - Accessories

Standard Accessories

1. Bushing

Transformer bushings connect the network cables to the primary and secondary windings through a metallic cover while electrically isolating them.

The bushing's rating is chosen depending on the voltage, current and applications.



Standard Accessories

1. Bushing

Description	Max	Max
	Voltage (kV)	Current (A)
DT 1/250	1	250
DT 1/630	1	630
DT 1/1000	1	1000
DT 1 / 2000	1	2000
DT 1/3150	1	3150
DT 3/250	3	250

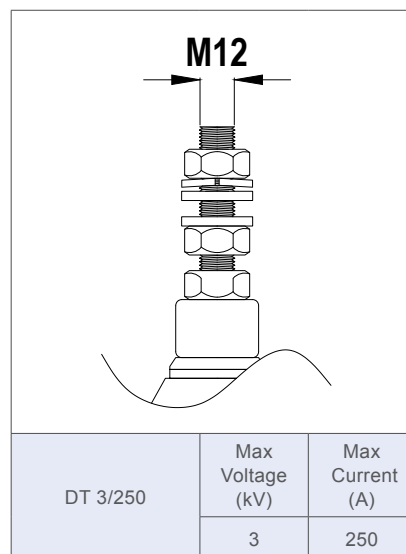
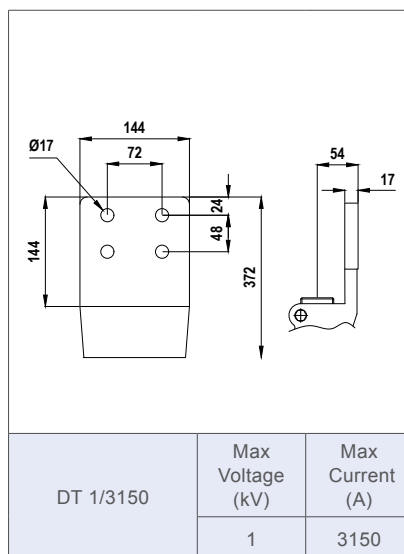
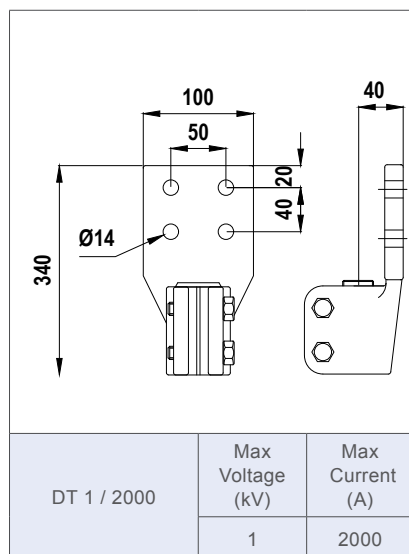
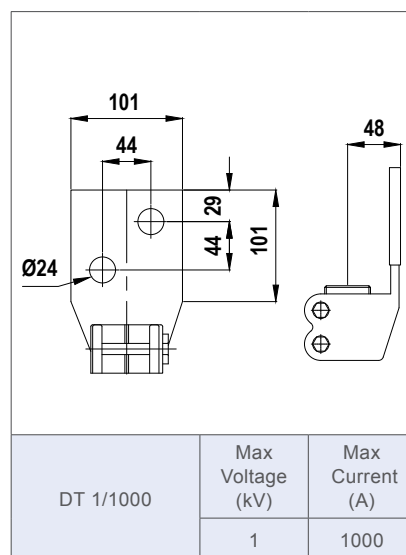
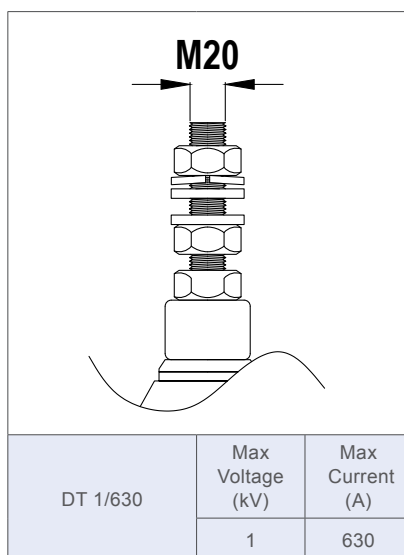
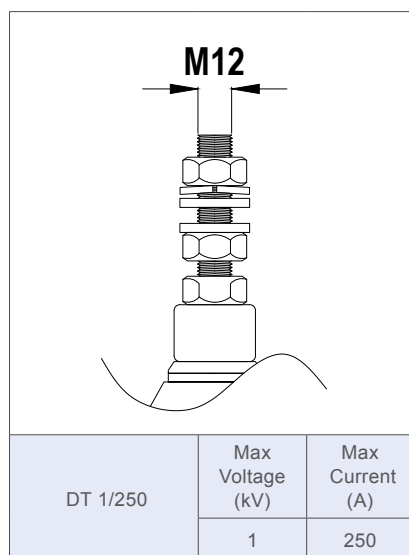

Bushing St.1 Suitable for Low Voltage Side

Standard Accessories

1. Bushing

Description	Max	Max
	Voltage (kV)	Current (A)
DT 3/630	3	630
Bar 3.6/850	3	850
Bar 3.6/1600	3	1600
Bar 3.6/2500	3	2500
DT 3/4500	3	4500
DT 3/6300	3	6300

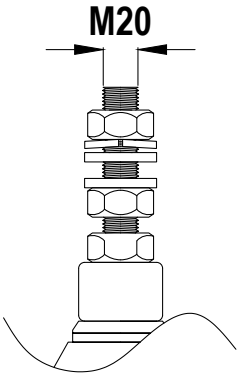
		
DT 3/630	Max Voltage (kV)	Max Current (A)
	3	630

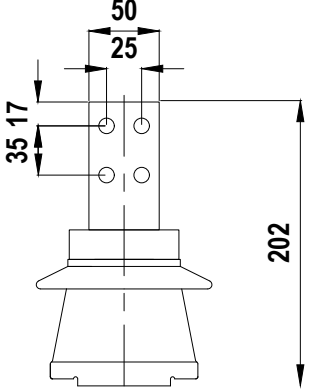
		
Bar 3.6/850	Max Voltage (kV)	Max Current (A)
	3	850

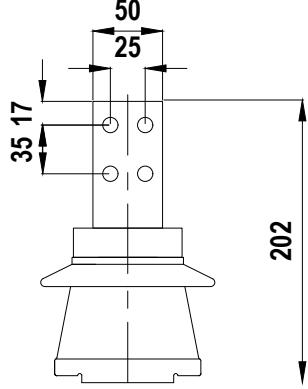
		
Bar 3.6/1600	Max Voltage (kV)	Max Current (A)
	3	1600

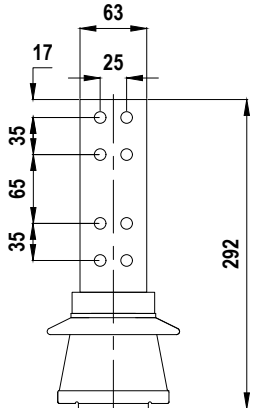
		
Bar 3.6/2500	Max Voltage (kV)	Max Current (A)
	3	2500

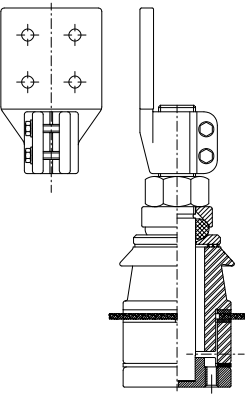
		
DT 3/4500	Max Voltage (kV)	Max Current (A)
	3	4500

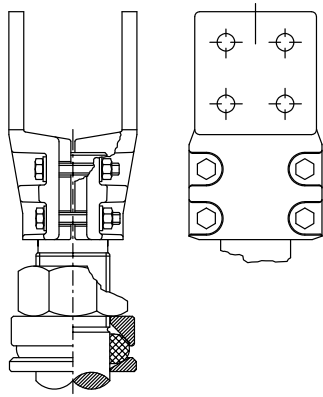
		
DT 3/6300	Max Voltage (kV)	Max Current (A)
	3	6300

Bushing St.1 Suitable for Low Voltage Side

Standard Accessories

1. Bushing

Description	Max	Max
	Voltage (kV)	Current (A)
Monoblock 1.1/800	1	800
Monoblock 1.1/1700	1	1700
Monoblock 1.1/2500	1	2500
Monoblock 1.1/4000	1	4000

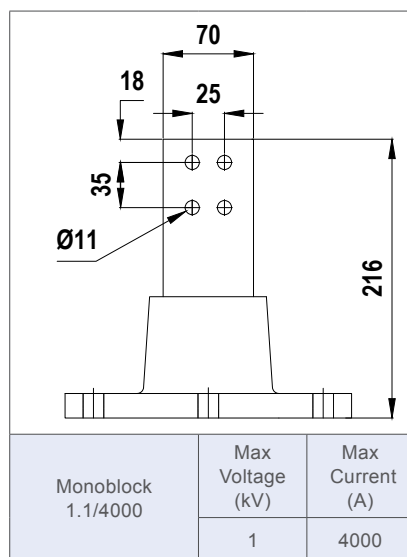
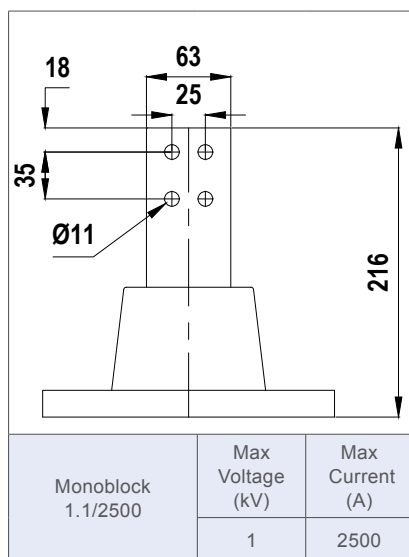
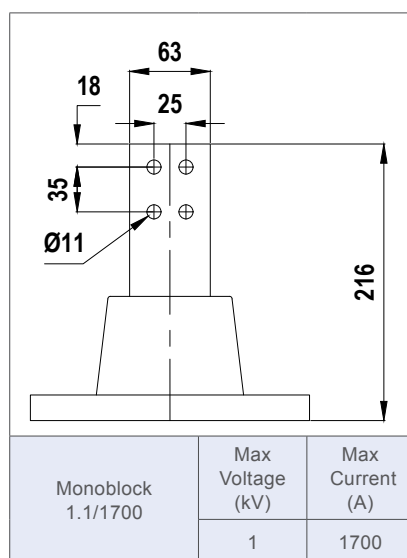
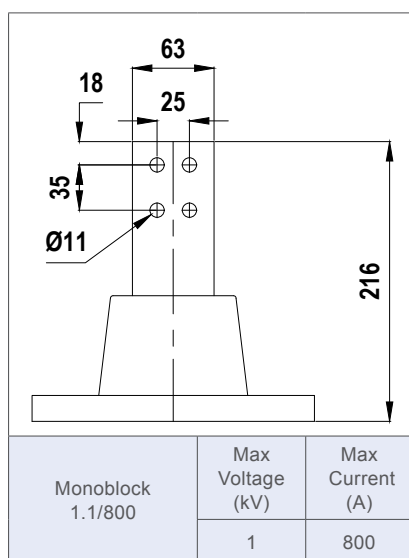

Bushing St.1 Suitable for Low Voltage Side

Standard Accessories

1. Bushing

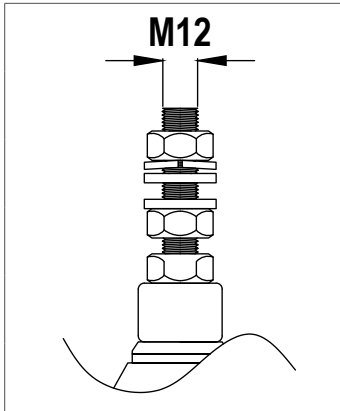

DIN Type Bushing			
Description	Max Voltage (kV)	Max Current (A)	Creepage (mm)
DT 20 NF/250 (440)	20	250	440
DT 30 NF/250(600)	30	250	600
30 / 250 - (1320)	30	250	1320
30 / 250 - (1650)	30	250	1650

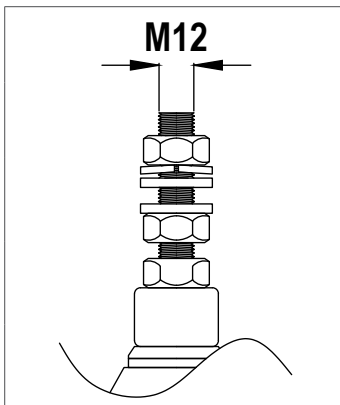

Heat Shrinkable Bushing			
Description	Max Voltage (kV)	Max Current (A)	Creepage (mm)
SH-17.5KV /250A-NI	17.5	250	170
SH-36 KV /250A	36	250	450

Shrinkable Material NOT in **alfanar** Scope of Supply

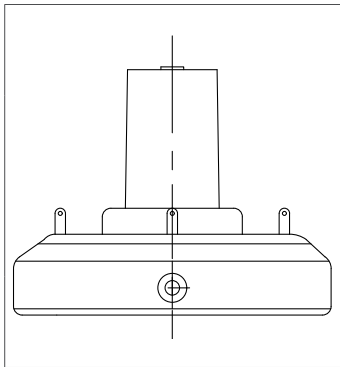

Plugin Bushing *			
Description	Max Voltage (kV)	Max Current (A)	Creepage (mm)
PL 24/250	24	250	N.A.

Suitable Elbow Connector NOT in **alfanar** Scope of Supply
MAX. Cable Size 120 mm.

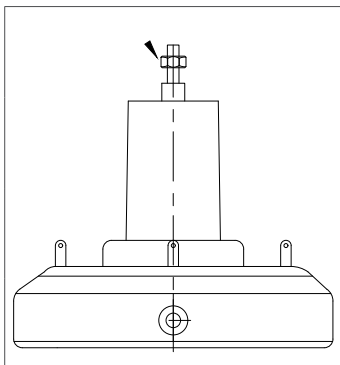

Plugin Bushing *			
Description	Max Voltage (kV)	Max Current (A)	Creepage
PL 36/630	36	630	N.A.

Suitable Elbow Connector NOT in **alfanar** Scope of Supply
MAX. Cable Size 300 mm.

Bushing St.2 Suitable for High Voltage Side

* For plugin bushing, suitable elbow connector to be used for cable connection.

Standard Accessories



٢. Cable Box

Cable boxes are enclosures for the transformer terminals. They provide protection from hazardous access to terminals, and protect the terminals from water, dust and mechanical impacts up to different degrees.

Protection degrees are described in IEC 60529. The cable box can be either top or side accessible depending on customer requirements.

The degree of protection which **alfanar** offers is IP 54 according to IEC 60529.



٣. Oil Level Indicator

Transformers can be equipped with an oil level indicator on the conservator, on the cover or on the side, depending on the design.

Magnetic and prismatic types of oil level indicators are available.



٤. Thermometer

The dial type thermometer indicates the maximum highest oil temperature reached during a certain period.

Two contacts are optional to provide an electrical signal, the first is for an alarm and the second for tripping.



٥. Pressure Relief Valve

Hermetically sealed transformers can be equipped with a pressure relief device, preset to 0.3bar/0.43bar.

When a pressure exceeding 0.3bar/0.43 bar occurs inside the transformer, the pressure relief valve opens to evacuate the overpressure.

∩. Earthing Terminal on Tank

Two earthing points are integrated in each tank, stainless stud, stainless flag with 12mm hole and stainless threaded M10 terminal are the available earthing point types.

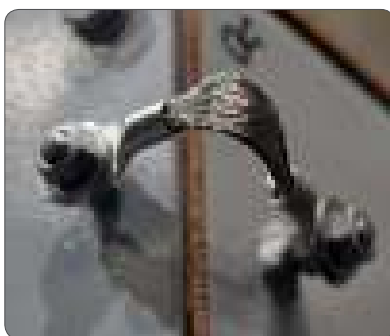

∪. Draining Valve

The drain valve is used to drain or sample the transformer oil from the transformer tank. These valves are fitted to the transformer tank by welding the pipe of the valve to the tank. These valves are 100% tested to ensure no leakages.



∧. Tap Changer

The network voltage is usually not stable and varies between different locations. To keep the secondary voltage at a nominal value, a linear tap changer is used.

The transformer by default comes with 5 position and steps $2x\pm 2.5$, other types of tap changers and number of position are available upon request. The different taps are indicated on the rating plate. The tap changer is off-circuit operated.



∩. Lifting lugs

Lifting lugs are used for untanking and lifting. 2 lugs are supplied for units weighing up to 3.5 tons, 4 lugs for heavier units.



Optional Accessories



١. DMCR Relay

A DMCR relay is a multifunctional device. It indicates the temperature and oil level and is equipped with electrical contacts for:

- Gas formation
- Pressure excess
- 2 Temperature levels: alarm and trip

٢. Oil Conservator

A cylindrical tank mounted on the supporting structure on the roof of the transformer (main tank), the main function of the oil conservator is to provide adequate space for expansion of oil inside the transformer for a breathing type tank transformer.



٣. Buchholz Relay

The Buchholz relay is used in conjunction with the conservator. Oil leakages, gases formation, and quick oil flow to the conservator are internal faults detected by the Buchholz relay. Dry contacts are provided to signal these alarms.

٤. Air Breather

The air breather is installed on the oil conservator, during normal operation the oil temperature changes resulting in an oil volume change, generating a bi-directional air flow from and to the conservator. The air breather contains silica gel which absorbs the air moisture. On delivery, the silica gel is pink, and becomes colorless when moisturized. Silica gel can be recycled by heating to 120 degrees until the color turns back to pink.

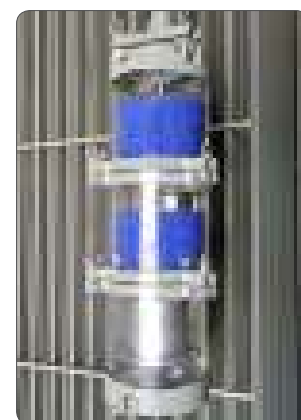

٥. Roller

Bi-directional rollers are used for ground mounted units: diameter 125mm for ratings up to 630 kVA, diameter 150/200 mm for higher ratings.

٦. Winding Temperature Indicator

This device measures the LV and HV winding temperature. A winding temperature indicator or WTI is also used as protection for the transformer.



7 – Package and Unit Substation

Design and Structure

alfanar Package and Unit Substations are completely self-contained solutions for power distribution that include outdoor duty enclosure, medium voltage switchgear, distribution transformer, low voltage panel, and accessories such as power factor improvement equipment, control and protection equipment, all providing a cost effective and efficient total installation. It can be manufactured as lighting substation also (LSS). Step Down/Step up substations, MV/MV, MV/LV, LV/:V

The solution packages are built in accordance to IEC standards and Saudi Electricity Company (SEC) specifications, where the distinguished design provides the customer with a high level of flexibility to cover a wide range of applications.

The construction of the unit substation is almost the same as the package substation but without the MV side.



MV Side (Ring Main Unit)

Each package substation contains the MV part which is in most cases the Ring Main Unit, known as the (RMU). **alfanar** has designed its own RMU under the name of SFA-RM.

SFA-RMs are designed for the supply of sustainable energy and protecting electrical equipment in secondary distribution networks up to 36kV.



SFA-RM units are the best solution for indoor/outdoor distribution substations, with their compact design they suit various network applications such as transformer substations, wind power plants, industrial zones.



The SFA-RM SF6 gas insulated units offer the following features:

- Compact design CESI type tested
- Switching units sealed in SF6 gas filled stainless steel tank
- High level of operator safety and operating reliability
- Embedded cable testing compartment, easy and safe cable testing without cable connection removal
- High quality tank welding, leakage rate of less than 0.1% per year
- Maintenance free unit with a life expectation of over 30 years
- Smart interlocking padlocking system for maximum operator safety
- Different feeder combinations with switch disconnecter and vacuum circuit breaker
- Compatible with SCADA systems for remote control and monitoring
- Motorized options for circuit breakers and switches
- High resistance to pollution and humidity

Technical Data Sheet

Rated Voltage	Up to 36kV	
Busbar Rating	Up to 630 A	
Rated Frequency	50 / 60 Hz	
Rated Nominal Current for Ring Switch	Up to 630A	
Rated Nominal Current for Tee-off Feeder	200/400 / 630 A	
Rated Short Time Withstand Current	21 KA / 1 Sec 21 KA / 3 Sec	
Internal Arc Calcification	A (FLR) 21 KA / 1 Sec (indoor & Outdoor)	
Rated Filling SF6 Gas Level for Insulation	1.2 bar (absolute)	
Minimum Functional SF6 Gas Level	1.1 bar (absolute)	
Relative Humidity	100%	
IP Class (Gas Tank / Indoor / Outdoor)	IP 67/ IP41 / IP54	
Rated Lightning Impulse Withstand Voltage	95 kV-peak	
Rated Power Frequency Withstand Voltage	38 kV-rms	
Applied Standard	IEC 62271-200	
Ring Switch Feeder (S)	Type of Switch-Disconnecter	General purpose, three-positioned (OPEN-CLOSED-EARTHED)
	Electrical Endurance Switch-Disconnecter/Earthing Switch	E3 / E0
	Mechanical Endurance	M1
	Nominal Current	Up to 630 A
	Short Circuit Making Current	21 kA (also valid for earthing switch) 54.6kA Peak
	Applied Standard	IEC 62271-103/102
TEE-OFF Feeder (B)	Type of Breaker	Vacuum
	Electrical Endurance	E3
	Mechanical Endurance	M1
	Nominal Current	Up to 630 A
	Short Circuit Breaking Current	21 kA
	Applied Standard	IEC 62271-100

Transformer

The transformer is the main part of every package and unit substation, where the type is changeable based on customer specification and application:

- Oil immersed conservator type instead of also hermetically sealed or dry type transformers can be installed
- Transformer bushings can be located on top or side of transformer as per customer needs
- Wide range of transformer capacities up to 3150 kVA
- Typical kVA's: 75, 100, 150, 160, 200, 250, 300, 315, 400, 500, 630, 750, 800, 1000, 1200, 1250, 1500, 1600, 2000, 2500, 3000, 3150
- **alfanar** package and unit substations are designed for simple and easy transformer installation on site or integrated into the PSS in the factory

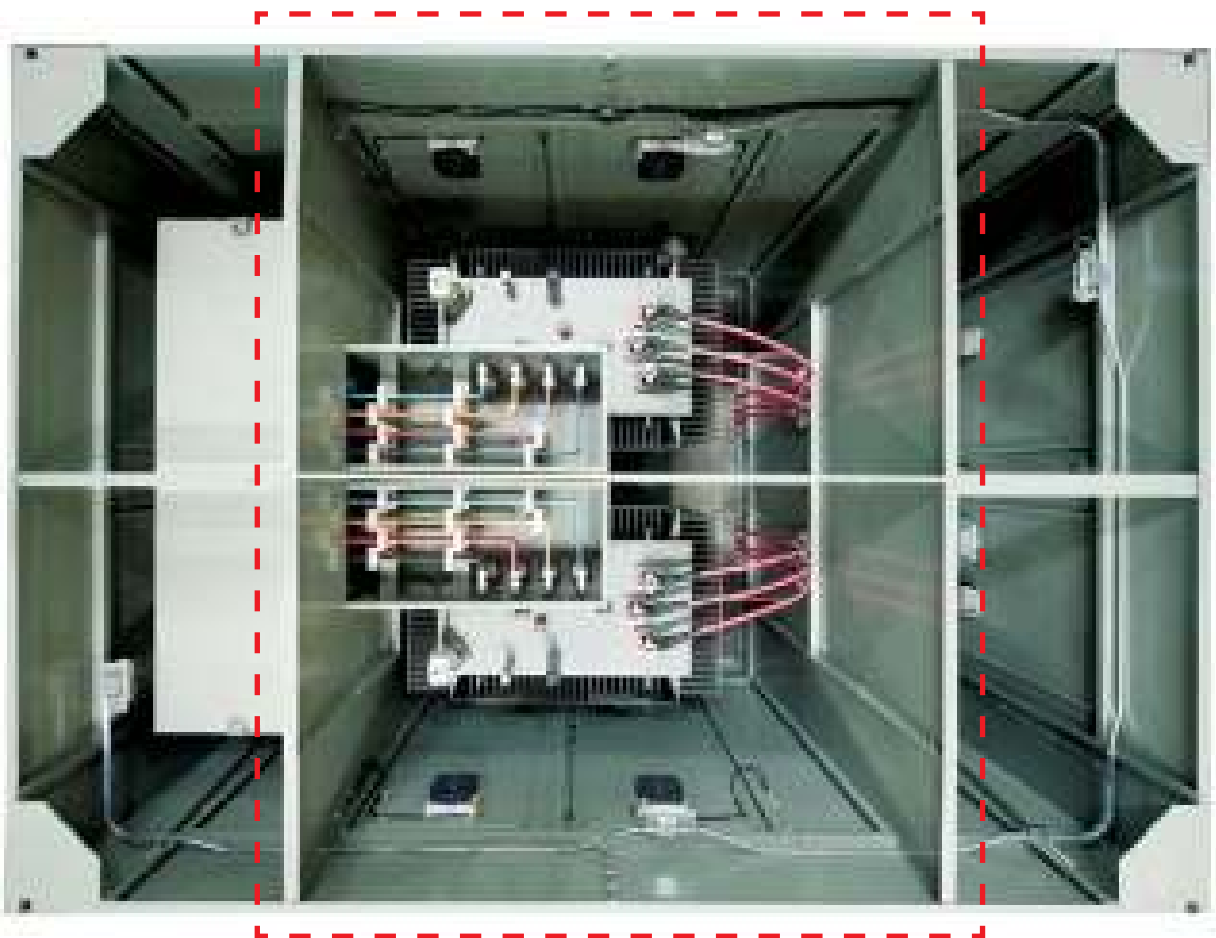

Low Voltage Panel

LV Panel is manufactured for safe distribution and efficient control of electricity in residential, commercial and industrial premises.

alfanar LV products conform to most national and international standards.



- Incoming feeder options can be direct connected, circuit breakers, busbar links
- The LV busbar rating depends on the transformer rating
- Various number and ratings of outgoing feeders depend on transformer size and customer requirements
- Equipment for metering, protection, BMS, SCADA and control is available
- Incoming breaker up to 5000 A (Drawout/Fixed, Manual/Motorized)
- Current Transformers
- Outgoing circuit breakers
- Sleeves busbar
- Special requirements-Auto transfer system (ATS), Power factor correction (PFC)

PSS Technical Features

General		
Ambient Temperature	Normal Operating	Customer requirement
Outdoor Color	RAL 7033, RAL7035	
Location of Operation	Outdoor	
Ventilation Type	Natural	
Degree of Protection	MV and LV	Up to IP 54
	Transformer	IP 23
Electrical Characteristics		
Rated Voltage (kV)	11, 13.8, 17.5, 24, 36 *	
Rated Frequency (Hz)	50, 60	
Ring Main Unit		
Load Break Switch (A)	400, 630	
Transformer Feeder	Circuit Breaker, Switch	
Transformer		
Rated Transformer Hermetically Sealed	Up to 3150 kVA	
Vector Group	Dyn 11 *	
Low Voltage Panel		
Main Incomer	Up to 5000 A	
Metering Devices	Digital, Standard	
Busbar	With Sleeves	Tin, Silver Plated
BMS	Can be interfaced with building management system for monitoring and controlling	

Standard Ratings and Dimensions

kVA	100-250	300-630	750-1250	1500-1600	2000-2500	3150
Length (mm)	2600	2962	3200	3518	3877	4200
Width (mm)	1600	1800	2200	2600	2800	3000
Height (mm)	1600	2200	2200	2225	2300	2500

Above Std. Dimensions are based on MV, Transformer and LV Sides.

8 – Service

To complement its position as a market leader of transformer manufacturing and supply, **alfanar** provides testing and commissioning services.

Our highly qualified and competent commissioning engineers undertake the complete electrical testing and commissioning of transformers and ancillary equipment.



This service is split into two groups:

- Dead Testing is performed on the circuits when the transformers are de-energized, and from the initial testing of the circuits to outline the insulation resistance of the new circuits, and the continuity for the ring circuits.
- Live testing is performed on the circuits if the result of the dead test has been recorded as unsatisfactory, and once the installation has been put back together following the dead testing.

List of tests conducted:

- 1- Visual inspection
- 2- Measurement of insulation resistance
- 3- Measurement of winding resistance
- 4- Measurement of voltage ratio and vector group
- 5- Energizing the transformer

9 - Testing

alfanar believes that quality means absolute congruity and compliance with customer's requirements and international standards.

Therefore, **alfanar** has equipped its testing lab with the most modern testing equipment and instrumentation devices to ensure conformity to the highest level of quality and safety, where every transformer produced by **alfanar** is tested according to IEC standards.



Routine Tests

- 1- Measurement of winding resistance
- 2- Measurement of voltage ratio and phase displacement
- 3- Measurement of short circuit impedance and load losses
- 4- Measurement of no-load losses and current
- 5- Dielectric routine tests
(separate source AC voltage withstand test and short duration induced over-voltage withstand test)
- 6- Measurement of insulation resistance

Type Tests

- 1- Temperature rise test according to IEC 60076-2
- 2- Lightning impulse test according to IEC 60076-3

Special Tests

- 1- Short circuit withstand test (as per IEC 60076-5)
- 2- Measurement of zero-sequence impedance(s) on three-phase transformers
- 3- Determination of sound levels (as per IEC 60076-10)
- 4- Measurement of the harmonics of the no-load current

10 - Inquiry Form

Ref No:

Customer Name :-

Project :-

CRM sub-opportunity :-

Feature of the Transformer

- | | | | |
|--|--|---------------------------------------|---|
| 1- Installation locatior | <input type="checkbox"/> Indoor | <input type="checkbox"/> Outdoor | <input type="checkbox"/> other |
| 2- Winding Material | <input type="checkbox"/> Copper | <input type="checkbox"/> Aluminum | |
| 3- Reference Standard | <input type="checkbox"/> I.E.C. 60076 | <input type="checkbox"/> SEC Standard | <input type="checkbox"/> Export <input type="checkbox"/> other |
| 4- Installation Type | <input type="checkbox"/> P.S.S | <input type="checkbox"/> U.S.S | <input type="checkbox"/> Pad <input type="checkbox"/> Pole |
| 5- Bushing | <input type="checkbox"/> Top bushing | <input type="checkbox"/> L.V. Side | <input type="checkbox"/> H.V Side <input type="checkbox"/> LV , HV Side |
| 6- Type of oil sealing | <input type="checkbox"/> Hearnatically | <input type="checkbox"/> Conservator | |
| 7- Max. altitude from sea level of operating location of transformer | <input type="checkbox"/> < = 1000 | <input type="checkbox"/> >1000 | |
| 8- Parallel operation required with another transformer | <input type="checkbox"/> Yes | <input type="checkbox"/> No | |
| 9- Transformer with tap change | <input type="checkbox"/> Yes | <input type="checkbox"/> No | |
| 10- LV . Cable box | <input type="checkbox"/> without | <input type="checkbox"/> Side | <input type="checkbox"/> Top <input type="checkbox"/> Top + Busbar |
| 11- HV . Cable box | <input type="checkbox"/> without | <input type="checkbox"/> Side | <input type="checkbox"/> Top |

Parameter of Transformer

- | | | | |
|---|----------------------|------------------------------------|--|
| 1 Quantity | Unit | <input type="text"/> | |
| 2 Rated power | kVA | <input type="text"/> | |
| 3 Rated Primary Voltage at No Load & Connection Of Widing | V | <input type="text"/> | <input type="checkbox"/> Delat <input type="checkbox"/> Star |
| 4 Rated Secondary Voltage at No Load & Connection Of Widing | V | <input type="text"/> | <input type="checkbox"/> Delat <input type="checkbox"/> Star |
| 5 Rated Secondary Voltage at Full Load @ Spcified PF | V | <input type="text"/> | |
| 6 Voltage Sequence | | <input type="checkbox"/> Step Down | <input type="checkbox"/> Step Up |
| 7 Rated frequency | | <input type="checkbox"/> 60 HZ | <input type="checkbox"/> 50 Hz |
| 8 Vector group | | <input type="checkbox"/> Dyn11 | <input type="checkbox"/> Dyn5 <input type="checkbox"/> Ynd11 |
| 9 If any another remark, Please specify in detail | <input type="text"/> | | |

Optional accessories required

Use Standard Accessories (Oil level indicator - Oil thermometer - Pressure relief valv Yes No

In Case Of No Please Choose From List And Add Your Requirement

- | | |
|--------------------------------------|------------------------------|
| Magnetic Oil Level Indicator (Side) | <input type="checkbox"/> Yes |
| Vertical Oil Level Indicator (Top) | <input type="checkbox"/> Yes |
| Dial Type Thermomter (Top) | <input type="checkbox"/> Yes |
| Dail Type Thermomter(Side) | <input type="checkbox"/> Yes |
| Oil Thermomter With 2 Contact (Top) | <input type="checkbox"/> Yes |
| Pressure Relief Valve | <input type="checkbox"/> Yes |
| Roller | <input type="checkbox"/> Yes |
| D.M.C.R Rellay | <input type="checkbox"/> Yes |
| Thermowall Class 130 (Scada RTD) | <input type="checkbox"/> Yes |

If any additional Accessories required Please Insert Here

Design Paramter If Non Standard

- | | | | | |
|-------------------|---|---------------------------|-------------------|------------------------|
| NO load Losses | : | <input type="text"/> Watt | Ambient Temp | <input type="text"/> C |
| Load Lossess | : | <input type="text"/> Watt | Oil Temp Rise | <input type="text"/> C |
| Voltage Impedance | : | <input type="text"/> % | Winding Temp Rise | <input type="text"/> |



For catalogue soft copy scan QR code

MKT_97535_TR_JAN18_01