



AN ISO 9001:2008 COMPANY

CABLE TRAYS | RACEWAYS
&
SUPPORT SYSTEMS



**Perforated Type
Ladder Type
Cable Raceways**

- **High Durability**
- **Dimensional Accuracy**
- **Corrosion Resistant**
- **Robust Construction**
- **Easy Installation**

Providing The Perfect Safety For Electrical Installations



AN ISO 9001:2008 COMPANY

I N D E X

About The Company 3

About Cable Trays 4

Manufacturing Range 5

Ladder Type Cable Trays 6

Accessories for Ladder Type 7

Perforated Cable Trays 8

Accessories for Perforated Cable Trays 9

Cable Raceways 10

Support System 11

Applications 12

Testings 15

Why BEC 15

Contact Details 16



AN ISO 9001:2008 COMPANY

ABOUT THE COMPANY

B.E.C. Conduits Pvt. Ltd, an ISO 9001: 2008 company, is India's premier organisation engaged in the manufacturing of ISI marked MS, GI Conduit Pipes, Pipe Fittings, Cable Trays, Raceways and Support Systems. The company is being managed by a team of dedicated professionals and experienced technical personnel. Competing with the pace of growth in the industry and the construction sector, the team is constantly working on innovating the products and delivering the best quality. Strategically located in Gurgaon, Haryana, the company has an excellent infrastructure. We have installed CNC hydraulic machines and other automatic machines within our infrastructure. We also have a state of the art laboratory which is equipped with latest testing equipments. Being a quality centric organisation, we strictly follow quality assurance plans.



Providing The Perfect Safety For Electrical Installations



AN ISO 9001:2008 COMPANY

ABOUT CABLE TRAYS

A cable tray is an assembly of metallic cable tray section and accessories that forms a rigid structural system to support cable.

NEED FOR CABLE TRAY SYSTEM

Today, plants and buildings are moving more towards automation there by requiring complex system of wiring and cable laying. Cable Trays have become an integral part of industrial and commercial construction by offering quick, economical and flexible solutions. Cable trays are capable of supporting all types of wiring such as high voltage power lines, power distribution cables, sensitive control wiring, telecom wiring and optical cables.

ADVANTAGES OF CABLE TRAY SYSTEM

- Cable tray system are easy to build and construct for complex routings.
- Modifying cable tray system, adding new cables or eliminating old cables is easy.
- Since cable tray system are not closed, moisture build up problems are eliminated and damage to cable insulation is also greatly reduced.
- Cable Tray systems offer under passed reliability resulting in less need for maintenance and less down time.
- Cable tray system provide more conductor ventilation which reduces cable heat.
- Cable tray designing can be highly customized as per customers requirements.

PERFORATED TYPE ●

LADDER TYPE ●

CABLE RACEWAYS ●

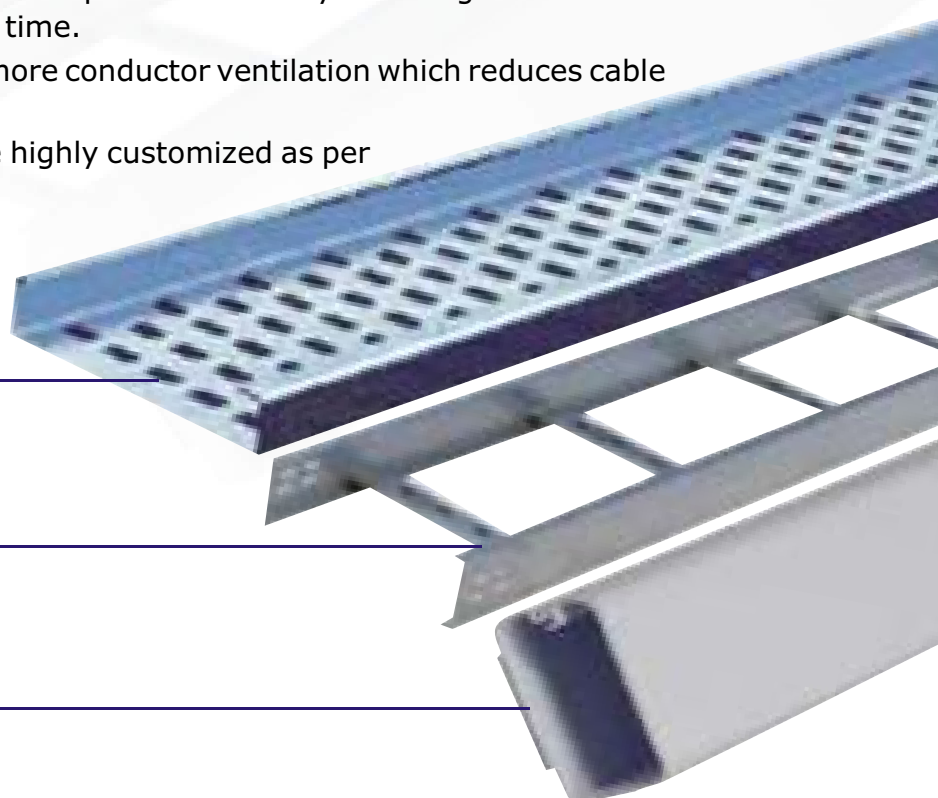

Providing The Perfect Safety For Electrical Installations



AN ISO 9001:2008 COMPANY

MANUFACTURING RANGE

LADDER TYPE CABLE TRAY

• WELDED CABLE TRAY

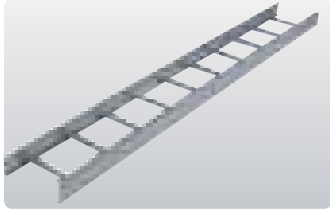

• BOLTED CABLE TRAY

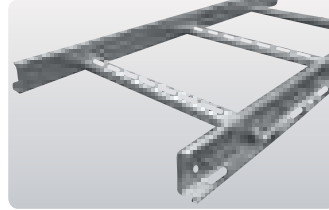

PERFORATED TYPE CABLE TRAY

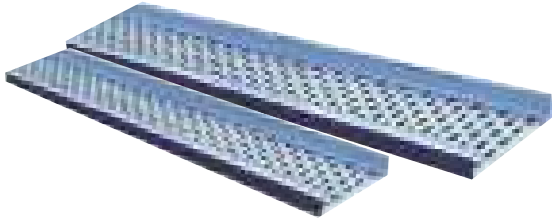

RACEWAYS

• C-TYPE

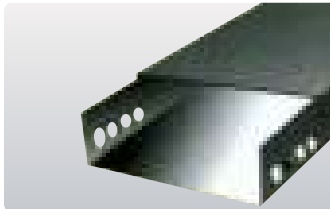

• G-TYPE

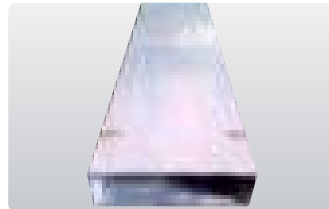

FITTINGS

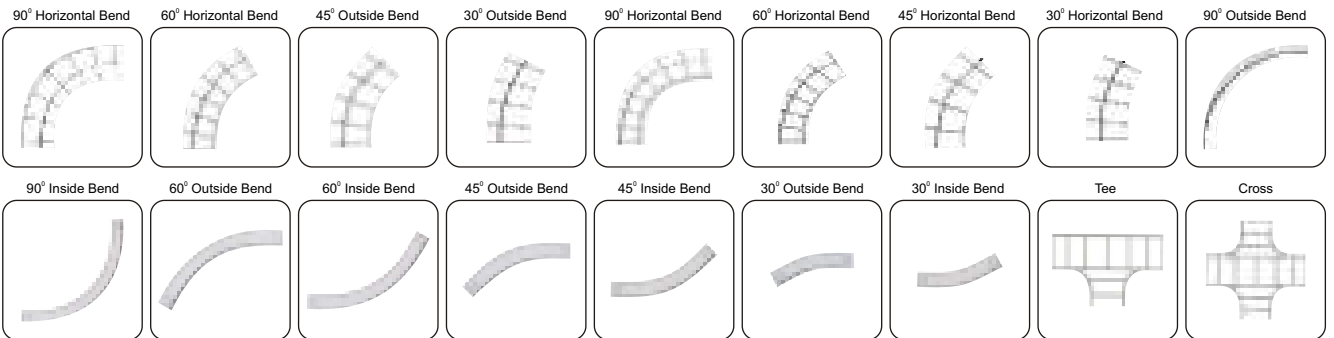

SUPPORT SYSTEMS

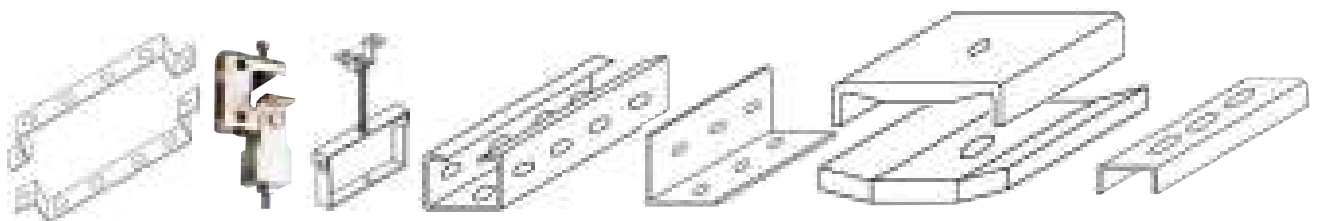

Providing The Perfect Safety For Electrical Installations



AN ISO 9001:2008 COMPANY

LADDER TYPE CABLE TRAYS

• WELDED CABLE TRAY

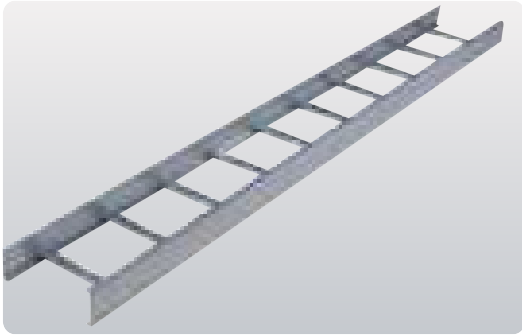

• BOLTED CABLE TRAY

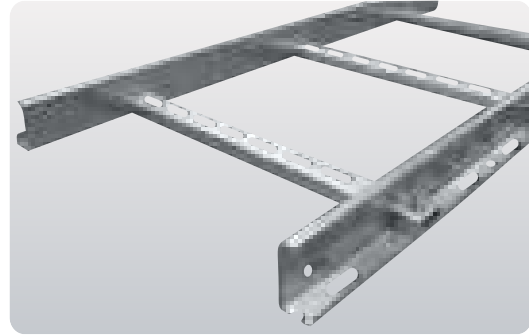

Ladder type cable trays consist of two side rails with rungs riveted to the bottom flange of the side rails. This type of cable tray provides maximum ventilation to heat producing cable such as power cables. Specific designs can be manufactured to meet special requirements.

DIMENSIONS

Width	100 to 1200mm
Height	As per requirement
Length	2.5 Metre / 3 Metre
Thickness	As per requirement

FINISHING

- PRE GALVANIZED
- M.S PAINTED
- HOT DIP GALVANIZED
- POWDER COATED

Providing The Perfect Safety For Electrical Installations



AN ISO 9001:2008 COMPANY

ACCESSORIES FOR LADDER TYPES

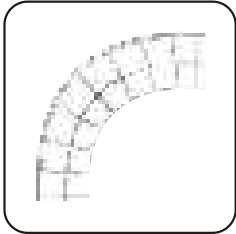

90° Horizontal Bend

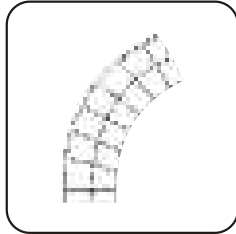

60° Horizontal Bend

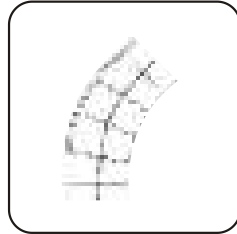

45° Outside Bend

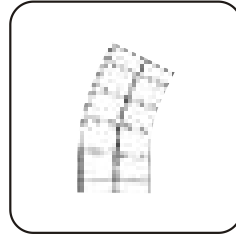

30° Outside Bend

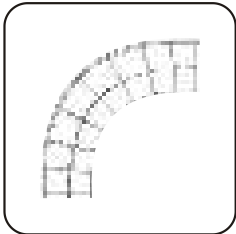

90° Horizontal Bend

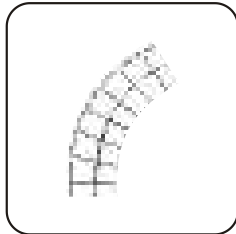

60° Horizontal Bend

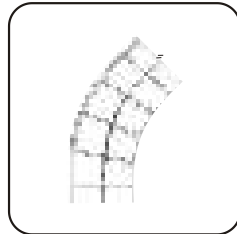

45° Horizontal Bend

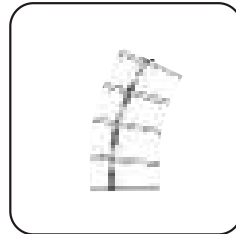

30° Horizontal Bend

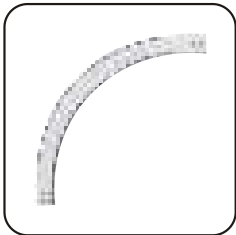

90° Outside Bend

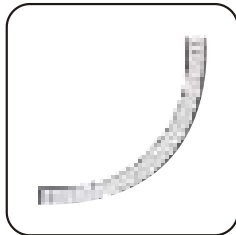

90° Inside Bend

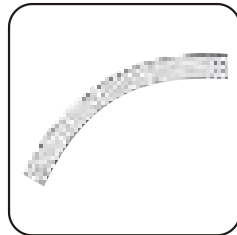

60° Outside Bend

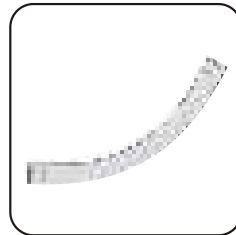

60° Inside Bend



45° Outside Bend

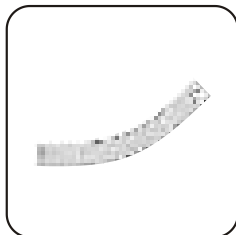

45° Inside Bend

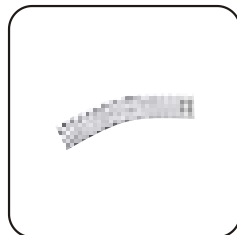

30° Outside Bend

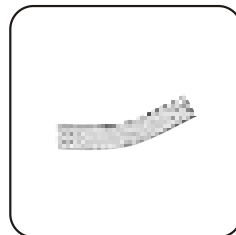

30° Inside Bend

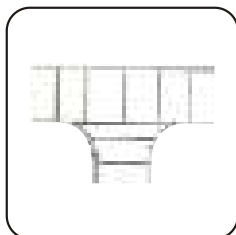

Tee

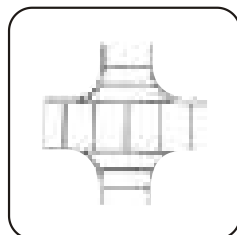

Cross

Providing The Perfect Safety For Electrical Installations



AN ISO 9001:2008 COMPANY

PERFORATED CABLE TRAYS

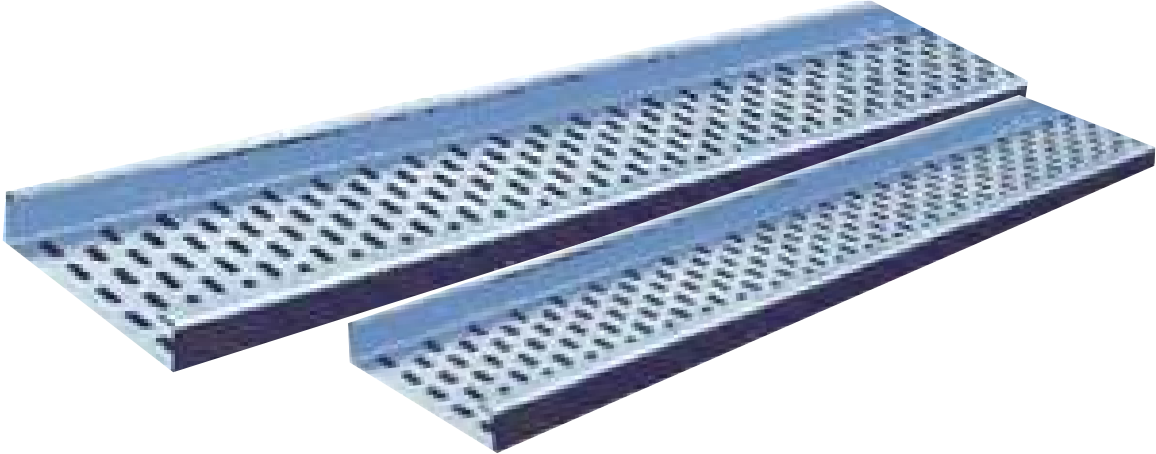

Perforated cable trays are fabricated from continuous roll formed structural quality steel. Trays are perforated from both sides of the cable tray. These cable trays are convenient for cables which requires both a degree of protection from external damage and some ventilation.

DIMENSIONS

Width	50 to 1200mm
Height	As per requirement
Length	2.5 Metre / 3 Metre
Thickness	As per requirement

FINISHING

- PRE GALVANIZED
- M.S PAINTED
- HOT DIP GALVANIZED
- POWDER COATED

Providing The Perfect Safety For Electrical Installations



AN ISO 9001:2008 COMPANY

ACCESSORIES FOR PERFORATED CABLE TRAYS

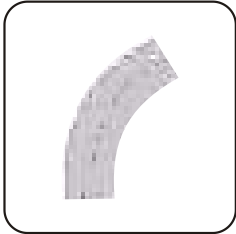

90° Horizontal Bend

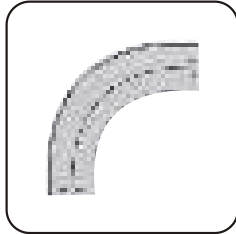

60° Horizontal Bend

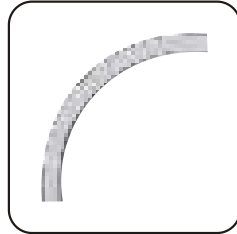

90° Outside Bend

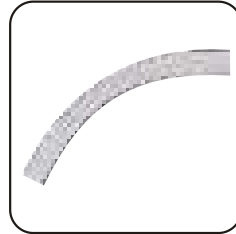

60° Outside Bend

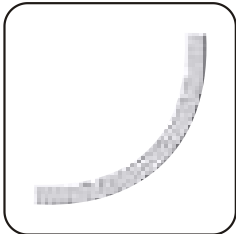

90° Inside Bend

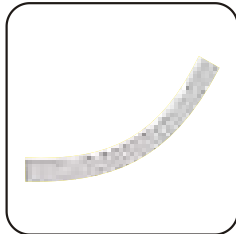

60° Inside Bend

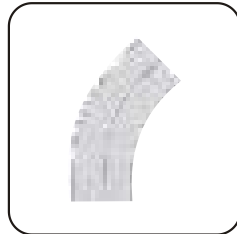

45° Horizontal Bend

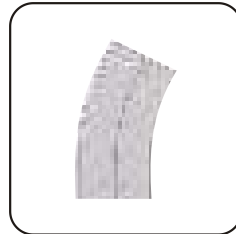

30° Horizontal Bend



45° Outside Bend

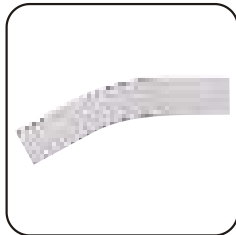

30° Outside Bend

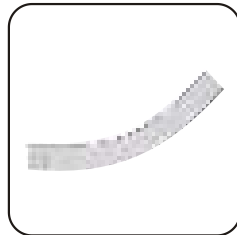

45° Inside Bend

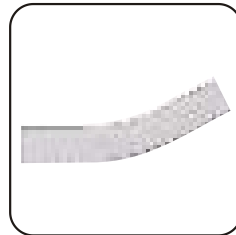

30° Inside Bend

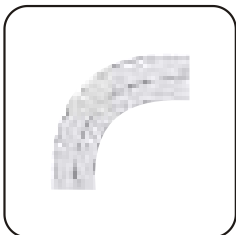

90° Horizontal Bend

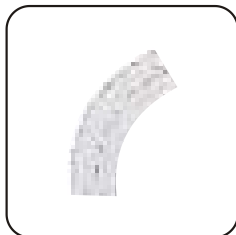

60° Horizontal Bend

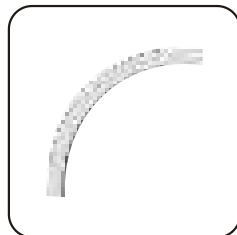

90° Outside Bend

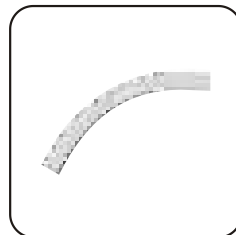

60° Outside Bend

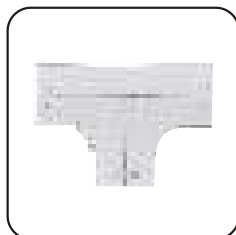

Tee

Providing The Perfect Safety For Electrical Installations



AN ISO 9001:2008 COMPANY

CABLE RACEWAYS

• C-TYPE

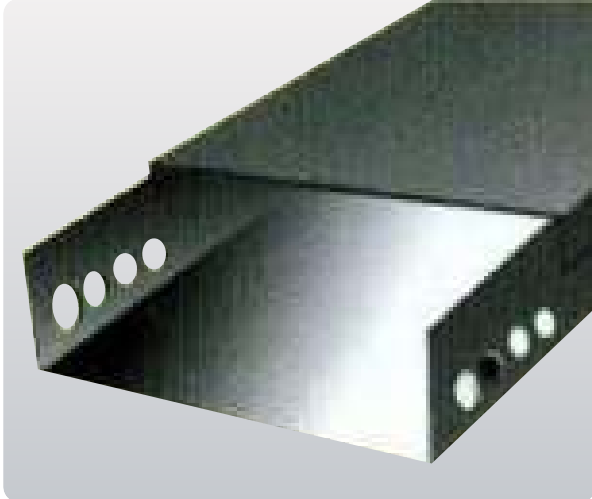

• G -TYPE

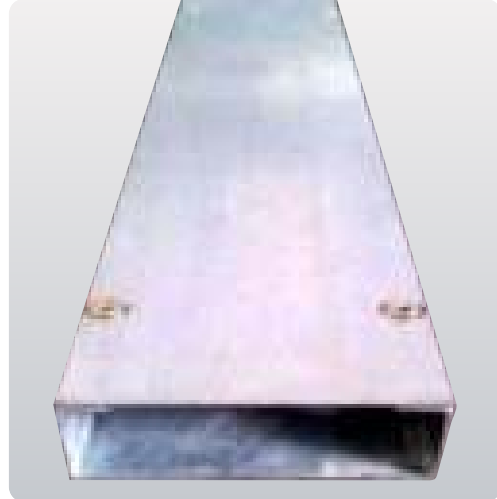

Cable Raceways are straight section of simple solid bottom cable trays constructed from single metal sheets. It is an enclosed conduit that forms the path for cable laying. Raceways protect wires and cables from heat humidity, corrosion, water intrusion and general physical threats.

DIMENSIONS

Width	100 to 1200mm
Height	As per requirement
Length	2.5 Metre/3 Metre
Thickness	As per requirement

FINISHING

- PRE GALVANIZED
- M.S PAINTED
- HOT DIP GALVANIZED
- POWDER COATED

Providing The Perfect Safety For Electrical Installations



AN ISO 9001:2008 COMPANY

SUPPORT SYSTEM



HANGING RACEWAY



BEAM CLAMP

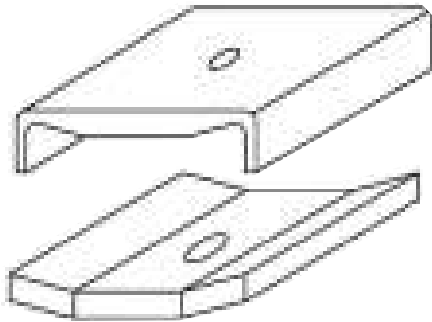

TOP & BOTTOM CLAMP

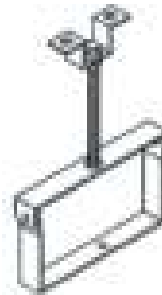

HANGING CLAMP

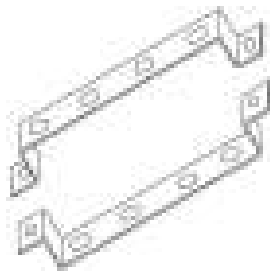

U CLAMP

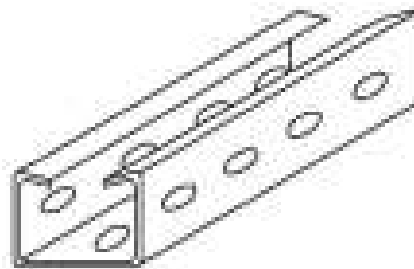

SLOTTED RACEWAY

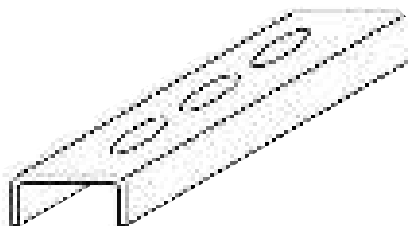

SLOTTED C CHANNEL

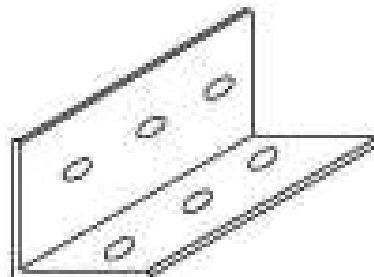

SLOTTED ANGLE

Providing The Perfect Safety For Electrical Installations



AN ISO 9001:2008 COMPANY

APPLICATIONS

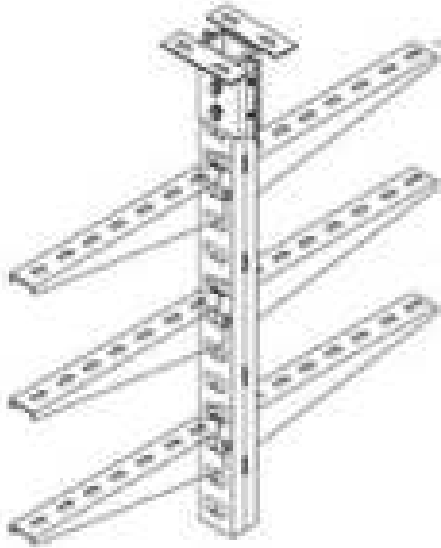

Roof Mounted Support for
Running Parallel cable tray systems



Roof Mounted Support for
Running Single or Multiple cable tray systems

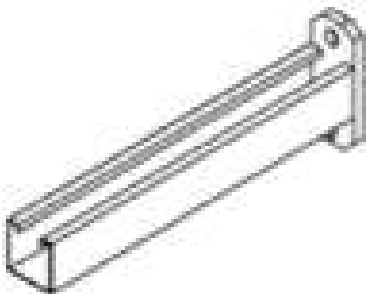

Wall Mounted Support Using Raceway

Providing The Perfect Safety For Electrical Installations



AN ISO 9001:2008 COMPANY

APPLICATIONS



Wall Mounted Support using
Channel Support & Angles

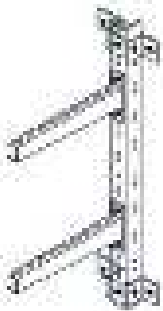

Wall Mounted Support using
Raceways & U-Clamps

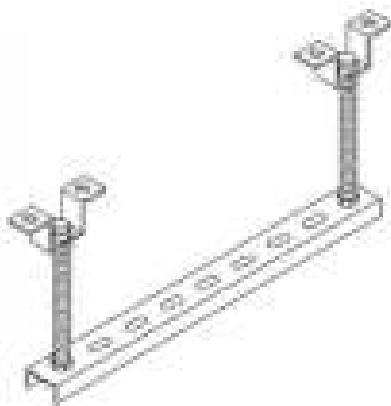

Roof Mounted Support using
Raceway/ Slotted Channel & U Clamps

Providing The Perfect Safety For Electrical Installations



AN ISO 9001:2008 COMPANY

APPLICATIONS

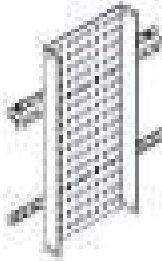

Vertical Support for Cable Tray using Raceway/ Slotted Channel with Bolts



Floor / Ceiling Mounted Support for Running Single Cable Trays

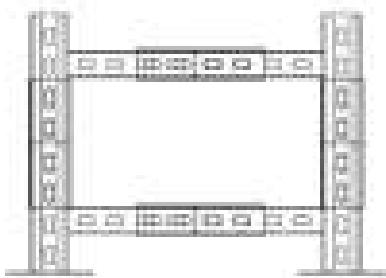

Floor / Ceiling Mounted Support for Running Multiple Cable Trays

Providing The Perfect Safety For Electrical Installations



AN ISO 9001:2008 COMPANY

TESTINGS

We are a quality centric organisation and are committed to deliver superior quality products. Our quality inspection team and quality control team test the raw materials, material in process and the finished product on daily basis. A modern testing laboratory has been designed at our works , which consists of all necessary equipment to test the quality of cable trays, raceways and support systems. We make sure that we deliver the best product to our customers in terms of dimensional accuracy, high tensile strength and better surface finishing.

WHY BEC

- Unmatched quality at competitive prices
- High dimensional accuracy
- Wide range of support systems
- Quality obsessive nature
- Wide Industrial experience
- Ethical Working
- Prompt services and execution of orders.

Providing The Perfect Safety For Electrical Installations



AN ISO 9001:2008 COMPANY

CONTACT DETAILS



B.E.C. CONDUITS PVT. LTD.

Begumpur Khatola, Gurgaon, Haryana-122001, India

Phone No.: +91 9313325777

E-mail: cabletrays@becconduits.com

Providing The Perfect Safety For Electrical Installations