

dowell's[®]

SINCE 1961

HOUSE OF DESIGNERS & MAKERS OF TERMINALS, TOOLS & CABLE GLANDS



 **dowell's[®]**
AN ISO 9001 : 2008 CERTIFIED CO.

PIONEERS IN SOLDERLESS TERMINALS, CRIMPING TOOLS & CABLE GLANDS



Dear Customer,

Dowell's Product represents accumulated experience since 1961 in wide range of terminal ends, connectors, crimping systems and cable glands. The company's Prime objective is to serve the world with updated technology in the cable termination field.

Laborious, time-taking, unreliable, soldering practice for termination is being simplified by introduction of dowell's crimping technique in the country.

Every attempt has been made to fulfil the needs of large number of electrical equipment manufacturers, engineers and electrical contractors with various specification to suit indian Industries.

Dowell's wining a proud of being leader in the crimping field, serves the country through strong dealers network, dowell's quality assured products have proven, firm standing in the international market which resulted into export to fourteen countries in Asia, Europe, New Zeland, Australia and Middle East.

Our R & D dept. welcomes your valued suggestions or problems for the constant innovation in crimping Technology.

We are very thankful to you for giving support to meet rising requirements of dowell's quality products.

Yours sincerely,

J.S. PATEL
Managing Director.

Dowell's Quality Excellence has proven it's merit again and again



Export Excellence Award Given by Hon. President of India Shri Neelam Sanjiv Reddy for the Year 1989-90



Dowell's Achievement of Export excellence award Continuously Since 1988



Export Excellence Award Given by Hon'ble State Finance Minister Mr. Ramrao Adik & Chair Person of Rajyasbha Nazma Hebtulla of the year 1990



Export Excellence Award Presented by Hon'ble State Finance Minister Shri Ramrao Adik of Maharashtra for the Year 1991-92



Best Excellence Export Award for the Year 1994-95 Presented by Mr. P.C. Alexander Governor of Maharashtra State



Export Excellence Award for the Year 1994-95 Presented by Hon'ble Governor of Reserve Bank of India Dr. Rangarajan

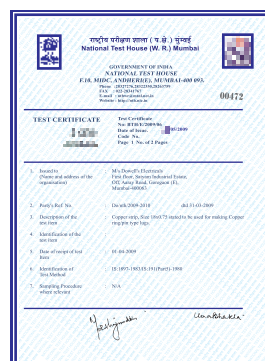
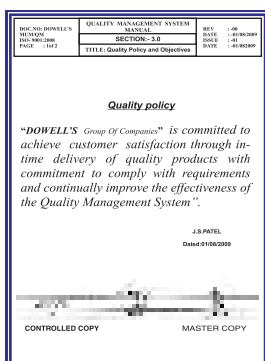
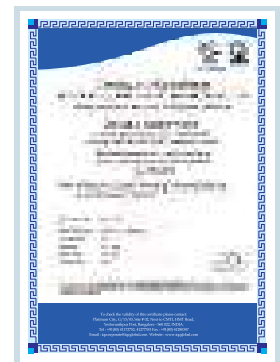
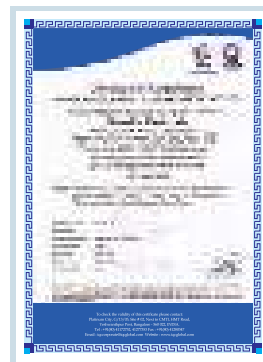
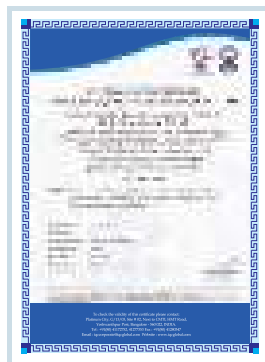
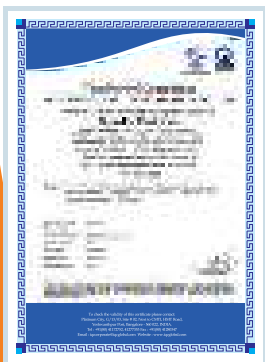



AN ISO 9001 - 2008 CERTIFIED CO.

SALES NETWORK

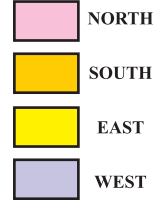
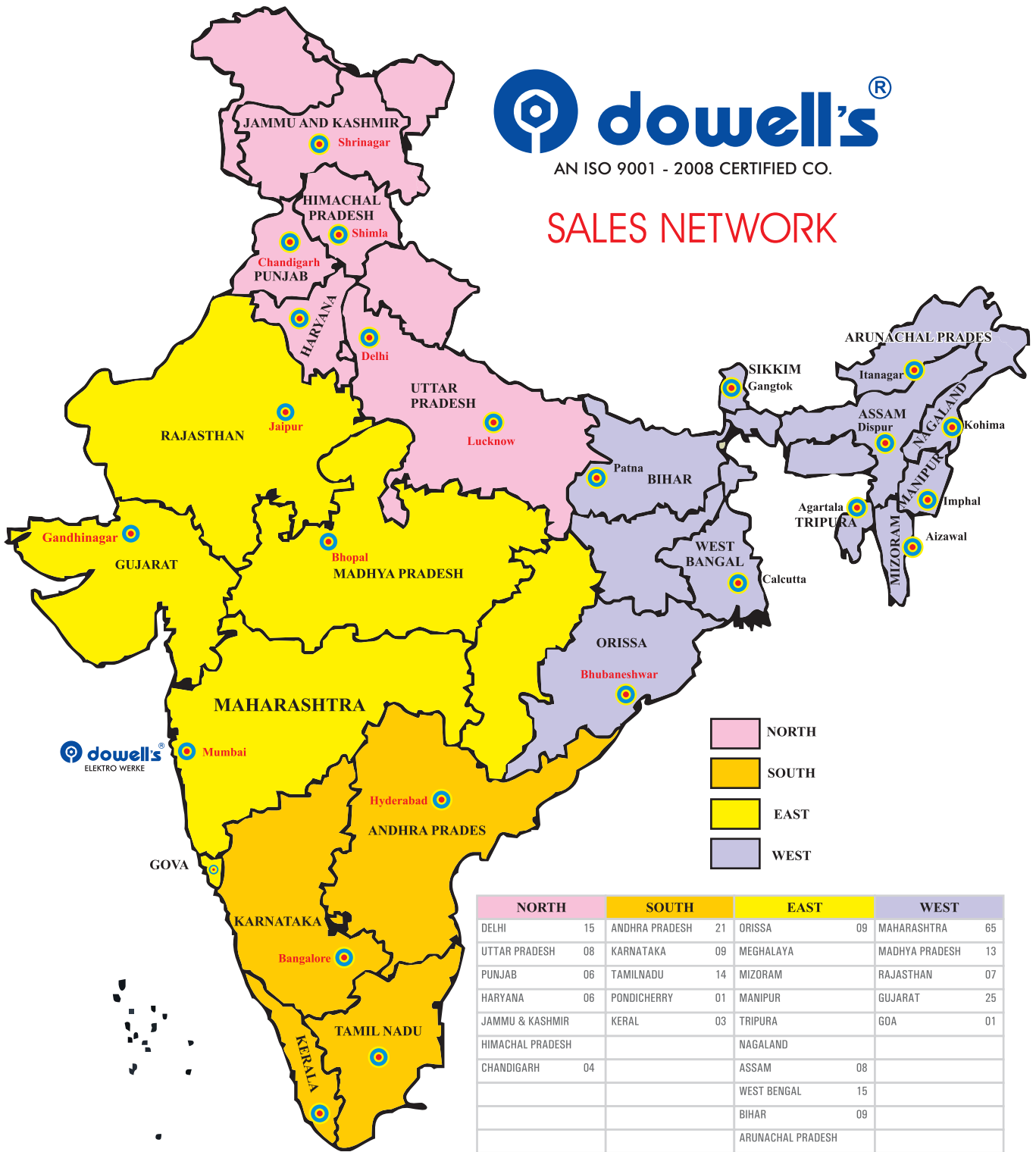

	NORTH	SOUTH	EAST	WEST			
DELHI	15	ANDHRA PRADESH	21	ORISSA	09	MAHARASHTRA	65
UTTAR PRADESH	08	KARNATAKA	09	MEGHALAYA		MADHYA PRADESH	13
PUNJAB	06	TAMILNADU	14	MIZORAM		RAJASTHAN	07
HARYANA	06	PONDICHERRY	01	MANIPUR		GUJARAT	25
JAMMU & KASHMIR		KERALA	03	TRIPURA		GOA	01
HIMACHAL PRADESH				NAGALAND			
CHANDIGARH	04			ASSAM	08		
				WEST BENGAL	15		
				BIHAR	09		
				ARUNACHAL PRADESH			
TOTAL	39	48	41	111			

TOTAL NO. OF DEALERS - 239



Admn. Office : 47/47A, Satguru Ind. Estate, 1st Floor, Off Aarey Road, Goregaon (E), Mumbai - 400 063.
 Phone : (91)-(022) - 2927 0875 / 2927 0876 / 2927 0878 Fax : (91)-(022) 2927 0877
 website: www.dowells.co.in email : dowells@sify.com, enquiry@dowells.co.in

Manufacturing Units : Goregaon (Mumbai), Silvasa-Amli & Masat (U.T), Sarigam & Jamnagar (Gujarat)



◀ Export Excellence Award for the Year 1998-99 Presented by Hon'ble Union Minister for Industry Mr. Omar Abdullah

Dowell's range of terminals & connectors Crimping tools & Cable Glands

Dowell's, a market leader in terminals connector and crimping tools, is supported by a nationwide marketing network of over 250 dealers. Its products are widely consumed mainly by power, telecommunication and automobile industries.

A Company's working efficiency and popularity is determined by the type of associates it has. Dowell's clientele includes leading companies like ABB, power stations, SEBs, BARC, BHEL, Crompton Greaves, Chitaranjan Locomotive Works Ltd., Diesel Locomotive Works, Electronics Corporation of India Ltd., GEC Alsthom (India) Ltd., Indian Railways, ISRO, Indian Telephone Industries Ltd., Larsen & Toubro, Maruti Udyog Ltd., National thermal Power, Corporation and Siemens Ltd.,

The Project is sufficiently geared to produce a vast range of terminals and crimping tools to cater to growing demand.

The solderless crimping technology is the field in which Dowell's has set superlative standards and consequently acquired a market leader status. Incorporated in 1961, the company, of the Dowell's Group, manufactures copper / aluminium terminals and hydraulic and non - hydraulic crimping tools, electronic connectors and telecommunication connector.

Dowell's Elektro Werke has many achievements to its credit. It manufactured plano type contact switches for the first time in India in 1961. It later diversified into electrical connection and development 5,000 types of terminals and joint accessories. It also exported cable terminals, connectors for copper and aluminium conductors and hand - operated hydraulic crimping tools, as well as non - ferrous metal semis like copper and aluminium flats, strips, rods, tubes etc.

In Malaysia, Australia, the US, etc., and has been the recipient of Regional Exporters Shield / Certificate of Export Excellence for years.

The main consumers of the company products are from the power and telecommunications sector. In view of the ongoing liberalisation, these industries should record a phenomenal growth in the coming years. Consequently, the prospects for the company are very bright.

Besides, the company is also expanding its base in automobile and telecommunication industries which are also going through a growth process.

A strong presence and a rewarding future is the key to success. Keeping this in mind, the company proposes to have a judicious mix of various non - ferrous terminals, connectors and crimping tools so as to achieve optimum profitability.

Everything depends on the forces which steer an organisation. The skill, the astuteness and the foresight are some factors which make the difference.

Mr. J. S. Patel, Dowell's Chairman & Managing Director, has around 50 years experience in non-ferrous metal trading and manufacturing. He has also lent his experience to several companies and is an active member of several chambers of commerce.

TABLE OF CONTENTS

Product Base	4-5
Terminals & Splices	6-7
Copper Tube Terminals Medium Duty	8
Copper Tube Terminals Heavy Duty & Long Barrel	9
Copper Tube In Line Connectors	10
Copper Reducer Terminals	10
Copper Tube Terminals Heavy Duty - XLPE Cable	11
Copper Tube In Line Connectors - XLPE Cable	12
Copper Tube In Line Connectors - Long Barrel	12
Copper Tube Terminals Long Barrel For Aluminium Conductors	13
Copper Tube Terminals DIN 46235	14-15
Copper Tube Terminals - High Voltage	16
Copper Connectors (Export Series)	16
Aluminium Tube Terminals	17
Aluminium In Line Connectors	18
Copper Tube Terminals Soldering Type	18
Aluminium Tube Terminals - Long Barrel	19
Aluminium Tube Terminals - Two Holes	20
Aluminium Ferrules For Aluminium XLPE Conductors	20
Aluminium Terminals Ends For Aluminium XLPE Conductors	21
Aluminium Reducer Terminals	22
Aluminium Tube Terminals DIN 46329	23
Aluminium In Line Connectors DIN 57295	23
Bimetallic Terminals (Copper Coated)	24-25
Copper In Line Connectors DIN 46267 Part I	26
Copper Connectors & End Sealing Ferrules	27
Copper Fork & Pin Terminals (Insulated & Non-Insulated)	28
Dowell's Corrosion Inhibiting Compound GTZ - 8785	29
Copper Ring Terminals (Insulated & Non-Insulated)	30-31
Copper Tube Terminals & Connectors For D.L.W.	32
Copper Tube Terminals & Connectors For C.L.W.	33
Copper Tube Terminals Extended Palm Blanks	34
Copper Tube Terminals For I.C.F.	34-35
Snap On Terminals	36-37
Crimping System	38-40
Cable Glands	41

Product Base

OFHC COPPER BILLET

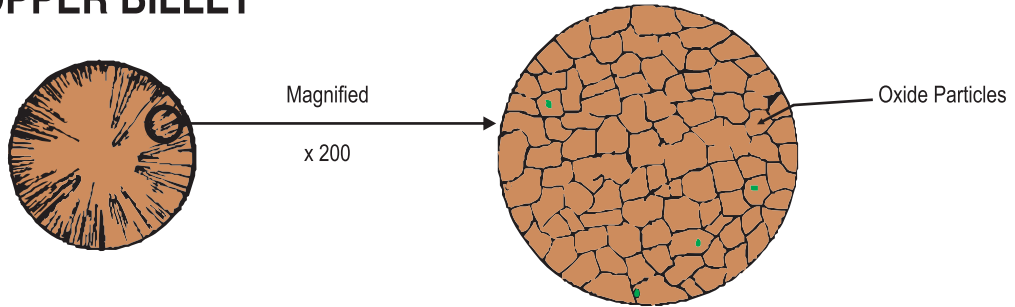

ETP COPPER WIRE BAR

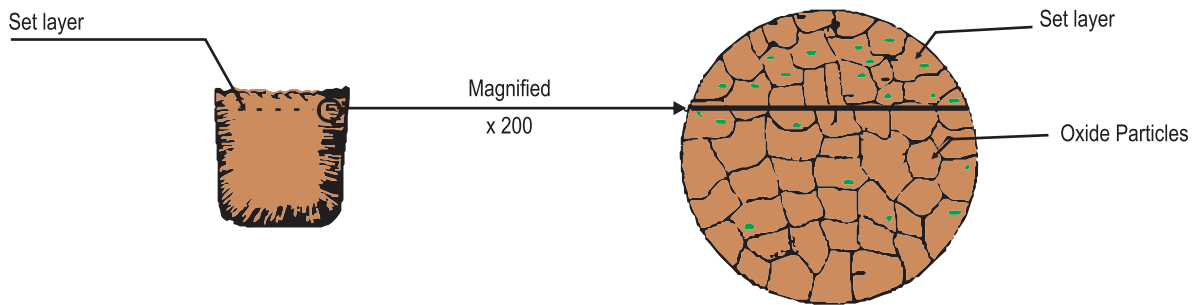

PRODUCT BASE :

Dowell's product quality starts from the raw material. Widely, Dowell's product range falls into two kinds of raw materials - Aluminium and copper designed to suit respective conductors.

O.F.H.C. COPPER

In practice electrical wires and cable terminals are made out of electrolytic tough pitch copper (ETP grade copper). This grade of copper contains 150 ppm to 400 ppm oxygen throughout the metal. In addition to that wire bars of ETP grade also have 8 to 10 mm thick set layer containing copper oxide particles.

Oxygen free high conductivity copper contains less than 30 ppm oxygen in the metal and is completely free from copper oxide particles. Lower oxygen content in oxygen free high conductivity copper has many advantages over ETP grade of copper as shown in the following table.

Use of OFHC copper in wire and cable industry is unknown in India due to its non-availability and high cost. But now the advantages of OFHC copper have been realised and **dowell's have taken the lead to manufacturer OFHC copper products.**

ELECTROLYTIC ALUMINIUM

Vast use of Aluminium conductors has inducted the ALS series of Solderless Aluminium Terminals and connector which are made out of pure electrolytic grade Aluminium conforming to IS 5082 grade TIE.

The product is generally supplied in 'O' condition.

The basic raw material used for terminals/ connectors contain minimum 99.5% Aluminium and electrical conductivity of minimum 60% IACS.

The comparison between ETP grade and OFHC grade will give firm standing to dowell's OFHC copper product at each installation

1. Contains less than .003% oxygen (30 ppm).	1. Contains .015% to .04% oxygen (150 ppm to 400 ppm).
2. Free from any set oxide layer.	2. Wire bars possess set oxide layer of 8-10mm thick on the surface through out its length.
3. Semi, and finished products such as tube, bars, strips & wires would be free from embedded oxide particles.	3. May contain embedded copper oxide particles.
4. Guarantees minimum 100% IACS conductivity, even on semis or finished products.	4. Possesses 100% conductivity but on processing semis and finished products, shows variation in conductivity to lower values.
5. Passes close bend test (hydrogen) embrittlement test.	5. Cannot pass close bend test.
6. Better thermal cycle behaviour.	6. Poor thermal cycle behaviour.
7. Consistency in brazed and welded joints can be achieved.	7. May lead to inconsistent brazed and welded joints.
8. Reliable and more durable in service against movements / jerks of electrical wires, e.g. telephone / automobile wires.	8. Conventionally used wire of this grade crack under similar conditions.
9. Most suitable for use in high vacuum devices.	9. Not at all suitable.
10. Crimping lugs never show even hair cracks after crimping with electrical cables.	10. May show cracks after crimping.
11. Gives reliability and longer service in electrical wiring, chokes, motors, dynamos, transformers, etc.	11. May give sudden failures.

TERMINALS AND SPLICES

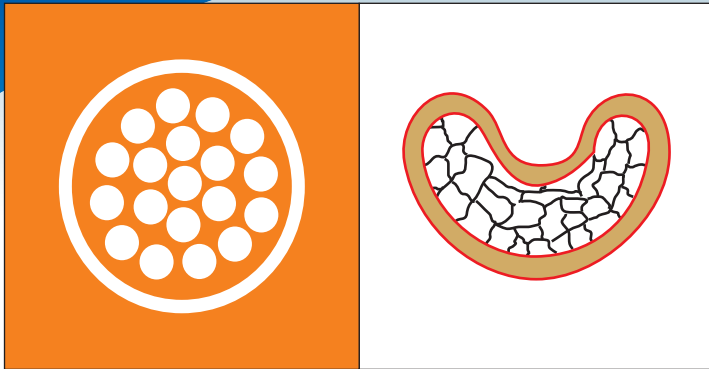

CRIMP METHOD:

Dowell's compression crimping method of terminating electrical wire is an perfect science. The technique is mechanical and uniform from first to last crimp. Which makes this process controllable. The variables common to other methods such as melting temp., flux composition, entrapped gases, heat deformation of conductors, oxidisation and the like are eliminated.

The termination from this method satisfies mechanical and electrical properties, required for 'quality' Termination.

INTRODUCTION :

Extensively designed for large power cables and leads, dowell's terminals and splices are perfectly designed for power generation and distribution. This makes electrical equipment subject to continuous operation, such as generators, motors and pannel boards, a perfect application for dowell's products. designed to support a wide range of standard copper and Aluminium wire sizes (upto 1000 mm²) with flexibility and reliability at a best quality price.

The dowell's product range is being catered in avariety of Terminals and splices to suit customers design requirements. dowell's invites the problems to solve it in the best technical and appropriate manner.

STD. PACKAGING.

RETAIL PACKING STANDARD

AMPS	BSS Ref.	Nos.	mm ²	Nos.	mm ²	Nos.
15 - 200	4E -	200	1.5 -	200	120 -	30
30 - 200	6E -	100	2.5 -	200	150 -	20
60 - 100	7E -	50	4.0 -	200	185 -	20
100 - 50	10E -	30	6 -	200	225 -	10
150 - 30	11E -	20	10 -	200	240 -	10
200 - 20	13E -	20	16 -	200	300 -	10
300 - 20	14E -	10	25 -	200	400 -	05
400 - 10	15E -	10	35 -	100	500 -	05
500/600 - 10	17E -	5	50 -	100	625 -	05
800 - 5	18E -	5	70 -	50	800 -	05
1000 - 5	20E -	5	95 -	50	1000 -	04

To expedite supplies indent your requirements as per above retail packing.

Requirements lesser than retail packing are subject to 10% surcharge.

QUALITY FINISH:

Dowell's terminals and splices are made of oxygen free high conductivity seamless tubes to ensure maximum conductivity. Special tin plating process protects from corrosion and assures trouble free service. Dowell's distinguished manufacturing process converts the copper into double thick tongue with short transfer section. This formulates best quality product with firm grip on Electrical and Mechanical properties.

STD. SIZE :

COMPARISON BETWEEN GERMAN, U.S.A. BRIT. ASSOC., STANDARD BOLT SIZE

German Din	U.S.A.	British Assorted
M2	# 1 = 9BA =	1.9 mm
	# 2 = 8BA =	2.2 mm
M2.6	# 3 = 7BA =	2.5 mm
M3	# 4 = 6BA =	2.8 mm
	# 5 = 5BA =	3.2 mm
M3.5	# 6 = 4BA =	3.5 mm
M4	# 8 = 3BA =	4.2 mm
M5	# 10 = 2BA =	4.8 mm
	# 12 = 1BA =	5 mm
M6	# 14 = 0BA =	6 mm
	# 1/4" = 1/4" =	
M8	#5/16" = 5/16" =	
M10	# 3/8" = 3/8" =	
M12	#7/16" = 7/16" =	
	# 1/2" = 1/2" =	
M16	# 5/8" = 5/8" =	
M20	# 3/4" = 3/4" =	
M26	# 1" = 1" =	

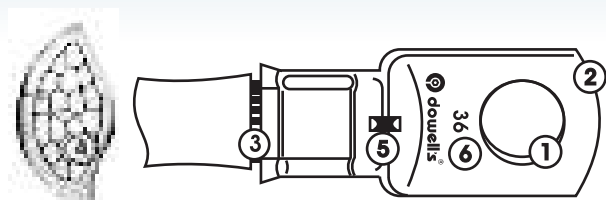

FEATURES :

1. SPECTRUM :

Stranded cables crimped with the **dowell's** tools, becomes a homogeneous mass with the **dowell's** terminals and connectors, Versatility in the stud hole available with **dowell's** helps solve any termination problem.

We specialise to supply 1,2 & 4 holes or without stud holes for specific requirements. Covering wide range from 1.5 to 1000mm² wire sizes **dowell's** terminals/ connectors provide reliability and low cost installation for power equipment wiring large cable size.

2. STRENGTH :

Dowell's terminals have formidable strength and resistance to vibration suitable for their intended use. This strength comes from the double thick tongue and short transfer section of the barrel, and is achieved without sacrificing any current carrying capacity. In addition great tensile strength is imparted to the **dowell's** terminals and connectors by means of **dowell's** perfectly designed dies and tools.

3. ECONOMY :

An important feature of **dowell's** product is low installed cost. Which is a result of perfect crimping system - a team of crimping tool and terminal.

The crimping system ensures correct crimp-each time without fail so-each installation with **dowell's** product saves your cost.

4. CONDUCTIVITY CORROSION RESISTANCE AND TEMPERATURE RISE.:

The nucleus of the **dowell's** termination method is the perfectly controlled crimping that forms terminal and connector barrel into homogeneous unit with conductor. Proper cold crimping brings the terminal into intimate contact with the conductor producing excellent resistance to corrosion.

5. INSPECTION PLUS : Standard heavy duty **dowell's** terminals are supplied with inspection slot in barrel, which facilitates operator to confirm whether conductors have been fully and properly inserted into the barrel. This check can be done before as well as after crimping. Bell mouth construction of barrel allows easy insertion of conductor into the barrel.

6. IDENTIFICATION MARKING : Standard heavy duty **dowell's** terminals are marked with respective conductor size of solid stranded wire and one size lower of flexible wire e.g. **CUS-248-630 S-500 F**. Normal compression type terminals copper and aluminium are marked with respective size of wire e.g. **CUS-29-240 mm² ALS 236-240 mm²**. Soldering terminals have current carrying capacity marking e.g. **DEW 208-400 DEW**.

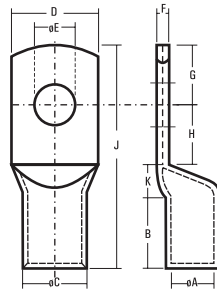

WE RESERVE THE RIGHTS AT ANY TIME TO MAKE ANY SPECIFICATION OR DIMENSIONAL CHANGES DEEMED NECESSARY TO ENSURE ADVANCEMENT IN THE DESIGN OR MANUFACTURE OF ANY PRODUCT

MM ²	E Bolt MMØ	øA	øC	D	F	B	K	H	G	J	Dowell's CAT. No.	RECOMMENDED TOOLS & DIES						
												SYB 95	SYT 185	SYT 400	SYD 20A	SYE 150A	SYT 102 R	STD PKG
2.5	M5	2.0	3.7	9	1.0	7	3	5	5	20	CUS-05							200
4.0	M6	3.1	4.8	11	1.0	7	3	6	6	22	CUS-06	SYA-427	SYT-17	SYT-2				200
6.0	M6	3.8	5.5	11	1.0	9	3	6	6	24	CUS-07							200
10	M6	4.4	6.2	11	1.3	9	3	6	6	24	CUS-08	JBR-1	R-1					200
16	M6	5.3	7.1	11	1.6	12	4	8	6	30	CUS-09	JBR-2	R-2					200
25	M6	7.0	9.0	13	2.0	12	5	12	8	37	CUS-10	JBR-3	R-3	RH-25				100
35	M6	8.0	10.0	15	2.0	12	5	12	8	37	CUS-11	JBR-4	R-4	RH-35				100
	M8	8.0	10.0	15	2.0	12	5	12	8	37	CUS-12							
50	M6	9.2	11.2	16	2.0	16	8	11	10	45	CUS-13							100
	M8	9.2	11.2	16	2.0	16	8	11	10	45	CUS-14	JBR-6	R-6	RH-50				
	M10	9.2	11.2	16	2.0	16	8	11	10	45	CUS-15							
70	M8	11.6	13.8	20	2.2	18	10	15	13	56	CUS-16							50
	M10	11.6	13.8	20	2.2	18	10	15	13	56	CUS-17	JBR-7	R-7	RH-50			HY-267	
	M12	11.6	13.8	20	2.2	18	10	15	13	56	CUS-18							
95	M10	12.8	15.6	23	2.8	20	10	15	13	58	CUS-19	JBR-9	R-9	RH-95				50
	M12	12.8	15.6	23	2.8	20	10	15	13	58	CUS-20							
120	M10	14.8	17.8	26	3.0	22	10	16	14	62	CUS-21							30
	M12	14.8	17.8	26	3.0	22	10	16	14	62	CUS-22	JBR-10	R-10	RH-120			HY-269	
	M16	14.8	17.8	26	3.0	22	10	16	14	62	CUS-23							
150	M10	16.0	19.6	28	3.6	26	11	18	15	70	CUS-24							20
	M12	16.0	19.6	28	3.6	26	11	18	15	70	CUS-25		R-11	RH-150	JDR-11	JER-11	HY-270	
	M16	16.0	19.6	28	3.6	26	11	18	15	70	CUS-26							
185	M12	18.0	22.0	32	4.0	30	11	21	21	83	CUS-27		R-12	RH-185	JDR-12	JER-12	HY-271	20
	M16	18.0	22.0	32	4.0	30	11	21	21	83	CUS-28							
225	M16	20.0	24.0	35	4.0	34	13	24	24	95	CUS-231			RH-185	JDR-13	JER-13	HY-272	10
240	M16	22.0	26.0	38	4.0	36	13	24	24	97	CUS-29			RH-240	JDR-14	JER-14	HY-272	10
	M20	22.0	26.0	38	4.0	36	13	24	24	97	CUS-30							
300	M16	24.0	28.7	42	4.7	39	13	26	25	103	CUS-31			RH-300	JDR-15	JER-15	HY-273	10
	M20	24.0	28.7	42	4.7	39	13	26	25	103	CUS-32							
400	M20	28.0	33.2	49	5.2	44	18	27	27	116	CUS-33			RH-400		JER-17	HY-274	5
500	M20	30.0	36.0	53	6.0	48	18	27	27	120	CUS-34					JER-18	JEM-279	5
630	M20	35.0	41.5	61	6.5	55	18	33	31	137	CUS-35					JER-19	JEM-280	5
800		39.0	46.3	67	7.3	65	25	38	37	165	CUS-062					JER-23		5
1000		43.0	53.8	76	10.8	90	30	45	45	210	CUS-076					JER-22		4

MATERIAL - EC GRADE COPPER IS -191

TOLERANCE=± 5%

FINISH - ELECTRO TINNED

COPPER TUBE TERMINALS HEAVY DUTY LONG BARREL

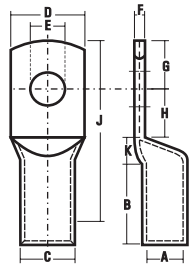

SYB - 95



SYT 102



SYE - 150

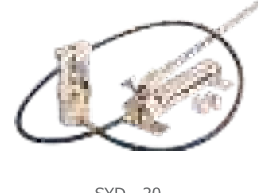

SYD - 20

MM ²	E Bolt MMø	øA	øC	D	F	B	K	H	G	J	Dowell's CAT. No.	RECOMMENDED TOOLS & DIES				
												SYB-95	SYD-20A	SYE-150A	SYT 102-R	STD PKG
25	M8	7.0	9.0	13	2.0	16	5	12	8	41	CUS-282	JBR - 3				100
35	M8	8.0	10.6	15	2.6	20	5	14	9	48	CUS-283	JBR - 4				100
50	M8	9.2	12.2	17	3.0	26	7	16	10	59	CUS-284	JBR - 6			HY - 267	100
70	M10	11.5	15.0	20	3.5	28	7	19	12	66	CUS-285	JBR - 9			HY - 268	50
95	M12	12.8	17.0	24	4.2	32	10	20	12	74	CUS-286	JBR - 10			HY - 269	50
120	M12	14.8	19.6	28	4.8	35	10	23	14	82	CUS-287		JDR - 11	JER - 11	HY - 270	30
150	M12	16.0	21.2	30	5.2	38	10	24	14	86	CUS-288		JDR - 12	JER - 12	HY - 271	20
185	M12	18.0	24.0	34	6.0	43	12	23	17	95	CUS-289		JDR - 13	JER - 13	HY - 272	20
240	M16	22.0	28.0	40	6.0	50	12	30	20	112	CUS-290		JDR - 15	JER - 15	HY - 273	10
300	M16	24.0	31.0	44	7.0	54	14	32	20	120	CUS-291				HY - 274	
400	M20	28.0	36.0	52	8.4	67	16	32	24	139	CUS-292				HY - 275	
500	M21	30.0	41.0	58	11.0	80	20	34	22	156	CUS-293				JEM - 279	
630	M21	35.0	46.0	66	11.0	93	22	38	28	181	CUS-294				JEM - 280	

MATERIAL-OFC COPPER BS - 1977 FINISH - ELECTRO TINNED

COPPER TUBE TERMINALS HEAVY DUTY - OPEN AT K



SYT - 17

SYA - 427

SYT - 2

SYB - 95



SYD-20B



SYE - 150B



SYT 102

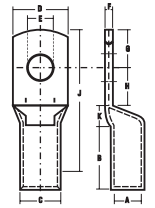

MM ²	E Bolt MMø	øA	øC	D	F	B	K	H	G	J	Dowell's CAT. No.	SYB 95	SYD 20B	SYE 150B	SYT 102-R	STD PKG
2.5	M4	2.4	4.0	8	1.0	7	2	5	4	18	CUS-388					200
4.0	M5	3.1	4.8	10	1.0	7	2	6	5	20	CUS-389	SYA-427	SYT-17	SYT-2		200
6.0	M5	3.8	5.5	10	1.2	9	3	6	5	23	CUS-390					200
10	M6	4.5	6.2	12	1.2	9	3	7	6	25	CUS-353	JBR-1				200
16	M6	5.4	7.1	12	1.4	12	4	7	7	30	CUS-354	JBR-2				200
25	M6	6.8	8.8	13	2.0	12	4	7	7	30	CUS-355	JBR-3				100
35	M8	8.2	10.6	15	2.4	12	5	9	9	35	CUS-356	JBR-4				100
50	M8	9.5	12.4	18	2.9	16	6	11	10	43	CUS-357	JBR-6	JDA-50	JEA-50	HY-267	100
70	M10	11.2	14.7	21	3.5	18	7	13	12	50	CUS-358	JBR-7	JDA-70	JEA-70	HY-268	50
95	M10	13.5	17.4	25	3.9	20	9	13	13	55	CUS-359	JBR-10	JDA-95	JEA-95	HY-269	50
120	M12	15.0	19.4	28	4.4	22	10	14	14	60	CUS-241		JDA-120	JEA-120	HY-270	30
150	M12	16.5	21.2	30	4.7	26	11	16	16	69	CUS-242		JDA-150	JEA-150	HY-271	20
185	M16	18.5	23.5	34	5.0	32	12	17	17	78	CUS-243		JDA-185	JEA-185	HY-272	20
240	M16	21.0	26.5	38	5.5	38	14	20	20	92	CUS-244		JDA-240	JEA-240	HY-273	10
300	M16	23.5	30.0	43	6.5	42	15	22	22	101	CUS-245		JDA-300	JEA-300	HY-274	10
400	M16	26.8	34.8	50	8.0	44	18	26	26	114	CUS-246		JDA-400	JEA-400	HY-275	5
500	M20	30.0	39.0	56	9.0	48	20	28	28	124	CUS-247			JEA-500	JEM-279	5
630	M20	35.0	45.0	65	10.0	56	22	33	33	144	CUS-248			JEA-630	JEM-280	5

MATERIAL - EC GRADE COPPER IS -191

TOLERANCE=± 5%

FINISH - ELECTRO TINNED

DIMENSION E, A CONFORM TO DIN 46235

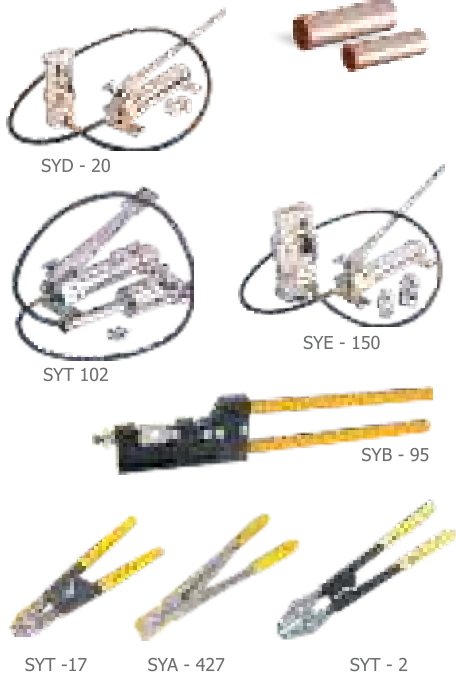
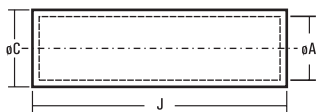

mm ²	øA	øC	J	Dowell's CAT. No.	RECOMMENDED TOOLS & DIES				
					SYB-95	SYD-20A	SYE-150A	SYT-102 R	STD PKG
1.5	1.6	3.2	15	EH-453					200
2.5	2.4	4.0	15	EH-454					200
4.0	3.1	4.8	15	CB-3	SYA-427	SYT-17	SYT-2		200
4.6	3.5	5.5	15	EH-455					200
6.0	3.8	5.5	15	CB-4					200
10	4.5	6.2	20	EH-460	JBR-1				200
16	5.4	7.1	20	CB-6	JBR-2				200
25	6.8	8.8	32	CB-24	JBR-3				100
35	8.2	10.6	36	CB-25	JBR-4				100
50	9.5	12.4	40	CB-26	JBR-5			HY-267	100
70	11.2	14.7	40	CB-51	JBR-6			HY-268	50
95	13.5	17.4	45	CB-52	JBR-9	JDR-9	JER-7	HY-269	50
120	15.0	19.4	45	CB-53		JDR-10	JER-8	HY-270	30
150	16.5	21.2	55	CB-54		JDR-11	JER-9	HY-271	20
185	18.5	23.5	65	CB-55		JDR-12	JER-10	HY-272	20
240	21.0	26.5	80	CB-56		JDR-14	JER-11	HY-273	10
300	23.5	30.0	85	CB-57		JDR-15	JER-12	HY-274	10
400	26.8	34.8	90	CB-58			JER-13	HY-275	5
500	30.0	39.0	100	CB-59			JER-14	JEM-279	5
630	35.0	45.0	110	CB-61			JER-15	JEM-280	5

COPPER REDUCER TERMINALS

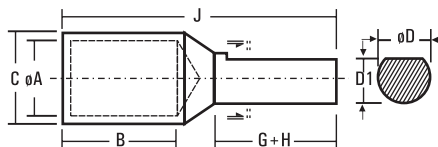

MM ²	øA	øC	øD	D-1	B	K	G-H	J	Dowell's CAT. No.	RECOMMENDED TOOLS & DIES					
										SYB-95	SYD-20A	SYT-150A	SYE-150 B	SYT-102 R	STD PKG
2.5	2.5	4.7	3.8	3.3	6	4	10	20	WPC-7	LINE CONNECTORS					200
4.0	2.8	4.7	3.8	3.3	6	4	10	20	WPC-16	SYA-427	SYT-17	SYT-2			200
6.0	3.1	4.7	3.8	3.3	6	4	10	20	WPC-18						200
10	3.8	5.5	3.8	3.3	9	4	10	23	WPC-20						200
10	4.4	6.2	3.8	3.3	9	4	10	23	WPC-22	JBR-1					200
16	5.3	7.1	3.8	3.3	13	4	13	30	WPC-2	JBR-2					200
25	7.0	9.0	6.0	5.5	12	5	15	32	WPC-25	JBR-3					100
35	8.0	10.0	7.5	6.5	12	5	20	37	WPC-4	JBR-4					100
50	9.2	11.2	7.5	6.5	16	5	20	41	WPC-26	JBR-6					100
70	11.3	13.8	7.5	6.5	18	5	20	43	WPC-27	JBR-7				HY-267	50
95	12.8	15.6	11.5	10.5	20	6	25	51	WPC-29	JBR-9				HY-268	50
120	14.8	17.8	11.5	10.5	22	6	32	60	WPC-35	JBR-10			JEA-120	HY-269	30
150	16.0	19.6	11.5	10.5	26	6	32	64	WPC-37		JDR-11	JER-11	JEA-150	HY-270	20
185	18.0	22.0	11.5	10.5	32	6	32	70	WPC-38		JDR-12	JER-12	JEA-185	HY-271	20
225	20.0	26.0	15.6	14.0	38	8	32	78	WPC-39		JDR-14	JER-14	JEA-240	HY-272	10
240	21.2	26.0	15.6	14.0	38	8	32	78	WPC-43		JDR-14	JER-14	JEA-240	HY-272	10
300	24.0	28.7	16.0	15.0	42	8	42	92	WPC-45		JDR-15	JER-15	JEA-300	HY-273	10
400	27.0	33.2	15.6	14.0	46	12	32	90	WPC-101			JER-17	JEA-400	HY-274	5

MATERIAL - EC GRADE COPPER IS -191

TOLERANCE=± 5%

FINISH - ELECTRO TINNED

WE RESERVE THE RIGHTS AT ANY TIME TO MAKE ANY SPECIFICATION OR DIMENSIONAL CHANGES DEEMED NECESSARY TO ENSURE ADVANCEMENT IN THE DESIGN OR MANUFACTURE OF ANY PRODUCT

COPPER TUBE TERMINALS HEAVY DUTY - OPEN AT K

TUBULAR TERMINAL ENDS FOR SOLDERLESS CRIMPING TO COPPER CONDUCTORS. COMPACT ALUMINIUM XLPE CABLES

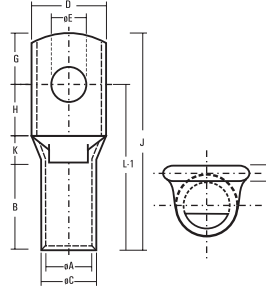

WE RESERVE THE RIGHTS AT ANY TIME TO MAKE ANY SPECIFICATION OR DIMENSIONAL CHANGES DEEMED NECESSARY TO ENSURE ADVANCEMENT IN THE DESIGN OR MANUFACTURE OF ANY PRODUCT

MM ²	øE	øA	øC	D	F	B	K	H	G	L-1	J	Dowell's CAT. No.	Retail Packing Nos.
1.5	5.2	1.8	3.7	8	1.0	5	2	5	4	12	16	CUS-538	100
1.5	6.5	1.8	3.7	10	0.8	5	2	6	5	13	18	CUS-539	100
2.5	4.2	2.4	4.0	8	1.0	7	2	5	4	14	18	CUS-388	100
2.5	5.2	2.4	4.0	10	0.8	7	2	6	5	15	20	CUS-540	100
2.5	6.5	2.4	4.0	10	0.8	7	2	6	5	15	20	CUS-541	100
4.0	5.2	3.1	4.8	10	1.0	7	2	6	5	15	20	CUS-389	100
4.0	6.5	3.1	4.8	10	1.0	7	2	6	5	15	20	CUS-543	100
6.0	5.2	3.8	5.5	10	1.2	9	3	6	5	18	23	CUS-390	100
6.0	6.5	3.8	5.5	12	1.0	9	3	9	6	21	27	CUS-544	100
6.0	8.4	3.8	5.5	12	1.0	9	3	9	6	21	27	CUS-545	100
10.0	6.5	4.5	6.2	12	1.2	9	3	7	6	19	25	CUS-353	100
10.0	8.4	4.5	6.2	12	1.2	9	3	9	6	21	27	CUS-547	100
16.0	6.5	5.4	7.1	12	1.4	12	4	7	7	23	30	CUS-354	100
16.0	8.4	5.4	7.1	12	1.4	12	4	9	7	25	32	CUS-549	100
20.0	8.4	6.0	7.7	12	1.7	12	4	9	7	25	32	CUS-550	100
25.0	6.5	6.8	8.8	13	2.0	12	4	7	7	23	30	CUS-355	100
25.0	8.4	6.8	8.8	18	1.4	12	4	11	10	27	37	CUS-551	100
25.0	10.5	6.8	8.8	18	1.4	12	4	11	10	27	37	CUS-552	100
35.0	6.5	8.2	10.6	15	2.4	12	5	9	9	26	35	CUS-542	100
35.0	8.4	8.2	10.6	15	2.4	12	5	9	9	26	35	CUS-356	100
35.0	10.5	8.2	10.6	18	2.0	12	5	11	10	28	38	CUS-554	100
50.0	8.4	9.5	12.4	18	2.9	16	6	11	10	33	43	CUS-357	100
50.0	10.5	9.5	12.4	18	2.9	16	6	11	10	33	43	CUS-556	100
70.0	8.4	11.2	14.7	21	3.5	18	7	13	12	38	50	CUS-557	50
70.0	10.5	11.2	14.7	21	3.5	18	7	13	12	38	50	CUS-358	50
70.0	13.0	11.2	14.7	21	3.5	18	7	13	12	38	50	CUS-559	50
95.0	10.5	13.5	17.4	25	3.9	20	9	13	13	42	55	CUS-359	50
95.0	13.0	13.5	17.4	25	3.9	20	9	13	13	42	55	CUS-561	50
120.0	13.0	15.0	19.4	28	4.4	22	10	14	14	46	60	CUS-241	30
120.0	17.0	15.0	19.4	28	4.4	22	10	16	16	48	64	CUS-546	30
150.0	13.0	16.5	21.2	30	4.7	26	11	16	16	53	69	CUS-242	20
150.0	17.0	16.5	21.2	30	4.7	26	11	16	16	53	69	CUS-564	20
185.0	17.0	18.5	23.5	34	5.0	32	12	17	17	61	78	CUS-243	20
240.0	17.0	21.0	26.5	38	5.5	38	14	20	20	72	92	CUS-244	10
240.0	21.0	21.0	26.5	38	5.5	38	14	20	20	72	92	CUS-567	10
300.0	17.0	23.5	30.0	43	6.5	42	15	22	22	79	101	CUS-245	10
300.0	21.0	23.5	30.0	43	6.5	42	15	22	22	79	101	CUS-569	10
400.0	17.0	26.8	34.8	50	8.0	44	18	26	26	88	114	CUS-246	5
400.0	21.0	26.8	34.8	50	8.0	44	18	26	26	88	114	CUS-571	5
500.0	21.0	30.0	39.0	56	9.0	48	20	28	28	96	124	CUS-247	5
550.0	21.0	31.7	41.4	60	9.7	52	20	30	30	102	132	CUS-573	5
630.0	21.0	35.0	45.0	65	10.0	56	22	33	33	111	144	CUS-248	5
800.0	----	39.0	50.6	73	11.6	78	17	40	35	135	170	CUS-599	5
1000.0	----	43.0	56.2	81	13.2	90	20	45	45	155	200	CUS-590	4

MATERIAL - EC GRADE COPPER IS -191

TOLERANCE=± 5%

FINISH - ELECTRO TINNED

COPPER TUBE IN - LINE CONNECTORS

CONNECTORS FOR SOLDERLESS CRIMPING TO COPPER CONDUCTORS. **COMPACT ALUMINIUM XLPE CABLE**

MM ²	øA	øC	J	Dowell's CAT. No.	Retail Packing Nos.
1.5	1.8	3.7	12	CB-41	100
2.5	2.4	4.0	15	EH-454	100
4.0	3.1	4.8	15	CB-3	100
6.0	3.8	5.5	15	CB-4	100
10	4.5	6.2	20	EH-460	100
10	5.4	7.1	20	CB-6	100
20	6.0	7.7	22	CB-47	100
25	6.8	8.8	32	CB-24	100
35	8.2	10.6	36	CB-25	100
50	9.5	12.4	40	CB-26	100
70	11.2	14.7	40	CB-51	50
95	13.5	17.4	45	CB-52	50
120	15.0	19.4	45	CB-53	30
150	16.5	21.2	55	CB-54	20
185	18.5	23.5	65	CB-55	20
240	21.0	26.5	80	CB-56	10
300	23.5	30.0	85	CB-57	10
400	26.8	34.8	90	CB-58	5
500	30.0	39.0	100	CB-59	5
550	31.7	41.4	100	CB-60	5
630	35.0	45.0	110	CB-61	5
800	39.0	50.6	150	CB-42	5
1000	43.0	56.2	170	CB-43	4

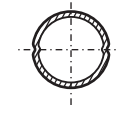
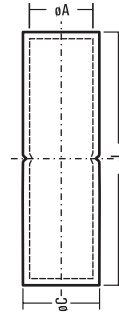

COPPER TUBE IN - LINE CONNECTORS - LONG BARREL

MM ²	øA	øC	J	Dowell's CAT. No.	RECOMMENDED TOOLS & DIES					STD PKG
					SYB-95	SYD-20A	SYD-20 B	SYE-150A	SYT-102 R	
1.5	1.6	3.2	23	CBL-453						200
2.5	2.0	3.7	23	CBL-23						200
4.0	3.1	4.8	23	CBL-3						200
6.0	3.8	5.5	23	CBL-4	SYA-427		SYT-17		SYT-2	200
10	4.4	6.2	30	CBL-460	JBR-1					200
16	5.3	7.1	30	CBL-6	JBR-2					200
25	7.0	9.0	38	CBL-7	JBR-3					100
35	8.0	10.0	45	CBL-8	JBR-4					100
50	9.2	11.2	53	CBL-9	JBR-6		JDA- 50			100
70	11.6	13.8	60	CBL-10	JBR-7		JDA- 70		HY-267	50
95	12.8	15.6	68	CBL-11	JBR-9		JDA- 95		HY-268	50
120	14.8	17.8	75	CBL-12	JBR-10		JDA- 120		HY-269	30
150	16.0	19.6	83	CBL-13		JDR-11	JDA- 150	JER-11	HY-270	20
185	18.0	22.0	90	CBL-14		JDR-12	JDA- 185	JER-12	HY-271	20
225	20.0	24.0	98	CBL-20		JDR-13	JDA- 240	JER-13	HY-272	10
240	22.0	26.0	98	CBL-15		JDR-14	JDA- 240	JER-14	HY-272	10
300	24.0	28.7	113	CBL-16		JDR-15	JDA- 300	JER-15	HY-273	10
400	28.0	33.2	135	CBL-17			JDA- 400	JER-17	HY-274	5
500	30.0	36.0	143	CBL-18				JER-18		5
630	35.0	41.5	158	CBL-19				JER-19		5
800	39.0	46.3	180	CBL-21				JER-23		5
1000	43.0	53.8	225	CBL-22				JER-22		4

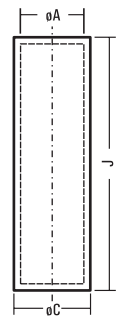
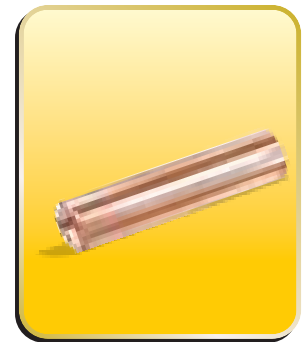

MATERIAL - EC GRADE COPPER IS -191

TOLERANCE=± 5%

FINISH - ELECTRO TINNED

WE RESERVE THE RIGHTS AT ANY TIME TO MAKE ANY SPECIFICATION OR DIMENSIONAL CHANGES DEEMED NECESSARY TO ENSURE ADVANCEMENT IN THE DESIGN OR MANUFACTURE OF ANY PRODUCT

LUGS SYSTEM

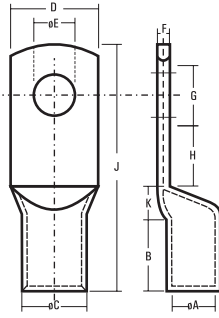

WE RESERVE THE RIGHTS AT ANY TIME TO MAKE ANY SPECIFICATION OR DIMENSIONAL CHANGES DEEMED NECESSARY TO ENSURE ADVANCEMENT IN THE DESIGN OR MANUFACTURE OF ANY PRODUCT

MM ²	E Bolt MM	øA	øC	D	F	B	K	H	G	J	Dowell's CAT. No.	RECOMMENDED TOOLS & DIES				
												SYB 95	SYD 20A	SYE 150A	SYT 102R	STD PKG
2.5	M5	2.0	3.7	9	1.0	10.5	3	5	5	23.5	CEB-05					200
4.0	M6	3.1	4.8	11	1.0	10.5	3	6	6	25.5	CEB-06	SYA-427	SYT-17	SYT-2		200
6.0	M6	3.8	5.5	11	1.0	13.5	3	6	6	28.5	CEB-07					200
10	M6	4.4	6.2	11	1.3	13.5	3	6	6	28.5	CEB-08	JBR-1				200
16	M6	5.3	7.1	11	1.6	18.0	4	8	6	36.0	CEB-09	JBR-2				200
25	M6	7.0	9.0	13	2.0	18.0	5	12	8	43.0	CEB-10	JBR-3				100
35	M6	8.0	10.0	15	2.0	18.0	5	12	8	43.0	CEB-11	JBR-4				100
	M8	8.0	10.0	15	2.0	18.0	5	12	8	43.0	CEB-12					
50	M6	9.2	11.2	16	2.0	24.0	8	11	10	53.0	CEB-13	JBR-6				100
	M8	9.2	11.2	16	2.0	24.0	8	11	10	53.0	CEB-14					
	M10	9.2	11.2	16	2.0	24.0	8	11	10	53.0	CEB-15					
70	M8	11.6	13.8	20	2.2	27.0	10	15	13	65.0	CEB-16	JBR-7				50
	M10	11.6	13.8	20	2.2	27.0	10	15	13	65.0	CEB-17					
	M12	11.6	13.8	20	2.2	27.0	10	15	13	65.0	CEB-18					
95	M10	12.8	15.6	23	2.8	30.0	10	15	13	68.0	CEB-19	JBR-9				50
	M12	12.8	15.6	23	2.8	30.0	10	15	13	68.0	CEB-20					
120	M10	14.8	17.8	26	3.0	33.0	10	16	14	73.0	CEB-21	JBR-10				30
	M12	14.8	17.8	26	3.0	33.0	10	16	14	73.0	CEB-22					
	M16	14.8	17.8	26	3.0	33.0	10	16	14	73.0	CEB-23					
150	M10	16.0	19.6	28	3.6	39.0	11	18	15	83.0	CEB-24		JDR-11	JER-11	HY-270	20
	M16	16.0	19.6	28	3.6	39.0	11	18	15	83.0	CEB-26					
185	M12	18.0	22.0	32	4.0	45.0	11	21	21	98.0	CEB-27		JDR-12	JER-12	HY-271	20
	M16	18.0	22.0	32	4.0	45.0	11	21	21	98.0	CEB-28					
225	M16	20.0	24.0	35	4.0	51.0	13	24	24	112.0	CEB-231		JDR-13	JER-13	HY-272	10
240	M16	22.0	26.0	38	4.0	54.0	13	24	24	115.0	CEB-29		JDR-14	JER-14	HY-272	10
	M20	22.0	26.0	38	4.0	54.0	13	24	24	115.0	CEB-30					
300	M16	24.0	28.7	42	4.7	58.0	13	26	25	122.0	CEB-31		JDR-15	JER-15	HY-273	10
	M20	24.0	28.7	42	4.7	58.0	13	26	25	122.0	CEB-32					
400	M20	28.0	33.2	49	5.2	66.0	18	27	27	138.0	CEB-33			JER-17	HY-274	5
500	M20	30.0	36.0	53	6.0	72.0	18	27	27	144.0	CEB-34			JER-18	JEM-279	5
630	M20	35.0	41.5	61	6.5	83.0	18	33	31	165.0	CEB-35			JER-19	JEM-280	5
800		39.0	46.3	67	7.3	98.0	25	38	37	198.0	CEB-62			JER-23		5
1000		43.0	53.8	76	10.8	135.0	30	45	45	255.0	CEB-76			JER-22		

MATERIAL - EC GRADE COPPER IS -191

TOLERANCE=± 5%

FINISH - ELECTRO TINNED

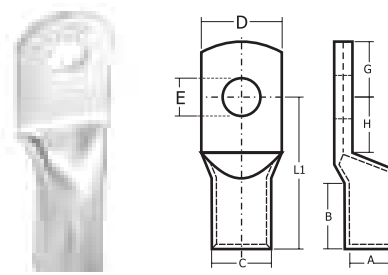

* Electrolytic High Conductivity Copper
* Electro Tinned Plated

WE RESERVE THE RIGHTS AT ANY TIME TO MAKE ANY SPECIFICATION OR DIMENSIONAL CHANGES DEEMED NECESSARY TO ENSURE ADVANCEMENT IN THE DESIGN OR MANUFACTURE OF ANY PRODUCT

Product Ref.	Conductor Size mm ²	Stud Hole	Dimensions mm							
			A	B	D	E	C	G	H	L1
DIN 6-5	6	M- 5	3.8	10	8.5	5.3	5.5	6.5	7.5	24
DIN 6-6	6	M- 6			8.5	6.4		7.5	8.0	
DIN 6-8	6	M- 8			13.0	8.4		10.0	10.0	
DIN 10-5	10	M-5	4.5	10	9.0	5.3	6.0	7.0	8.5	27
DIN 10-6	10	M-6			9.0	6.4		7.5	8.5	
DIN 10-8	10	M-8			13.0	8.4		10.0	10.0	
DIN 16-6	16	M-6	5.5	20	13.0	6.4	8.5	7.5	8.0	36
DIN 16-8	16	M-8			13.0	8.4		10.0	10.0	
DIN 16-10	16	M-10			17.0	10.5		12.0	12.0	
DIN 16-12	16	M-12			18.0	13.0		13.0	13.0	
DIN 25-6	25	M-6	7	20	14.0	6.4	10.0	7.5	8.0	38
DIN 25-8	25	M-8			16.0	8.4		10.0	10.0	
DIN 25-10	25	M-10			17.0	10.5		12.0	12.0	
DIN 25-12	25	M-12			19.0	13.0		13.0	13.0	
DIN 35-6	35	M-6	8.2	20	17.0	6.4	12.5	7.5	8.0	42
DIN 35-8	35	M-8			17.0	8.4		10.0	10.0	
DIN 35-10	35	M-10			19.0	10.5		12.0	12.0	
DIN 35-12	35	M-12			21.0	13.0		13.0	13.0	
DIN 35-14	35	M-14			21.0	15.0		14.5	14.5	
DIN 50-8	50	M-8	10	28	20.0	8.4	14.5	10.0	10.0	52
DIN 50-10	50	M-10			22.0	10.5		12.0	12.0	
DIN 50-12	50	M-12			24.0	13.0		13.0	13.0	
DIN 50-14	50	M-14			24.0	15.0		14.5	14.5	
DIN 50-16	50	M-16			28.0	17.0		16.0	16.0	
DIN 70-8	70	M-8	11.5	28	24.0	8.4	16.5	10.0	10.0	55
DIN 70-10	70	M-10			24.0	10.5		12.0	12.0	
DIN 70-12	70	M-12			24.0	13.0		13.0	13.0	
DIN 70-14	70	M-14			24.0	15.0		14.5	14.5	
DIN 70-16	70	M-16			30.0	17.0		16.0	16.0	
DIN 95-8	95	M-8	13.5	35	28.0	8.4	19.0	12.0	12.0	65
DIN 95-10	95	M-10			28.0	10.5		12.0	12.0	
DIN 95-12	95	M-12			28.0	13.0		13.0	13.0	
DIN 95-14	95	M-14			28.0	15.0		14.5	14.5	
DIN 95-16	95	M-16			32.0	17.0		16.0	16.0	
DIN 120-10	120	M-10	15.5	35	32.0	10.5	21.0	15.0	16.0	70
DIN 120-12	120	M-12			32.0	13.0		16.0	17.0	
DIN 120-14	120	M-14			32.0	15.0		18.0	18.0	
DIN 120-16	120	M-16			32.0	17.0		19.0	20.0	
DIN 120-20	120	M-20			38.0	21.0		21.0	22.0	

MATERIAL - EC GRADE COPPER IS -191

TOLERANCE=± 5%

FINISH - ELECTRO TINNED

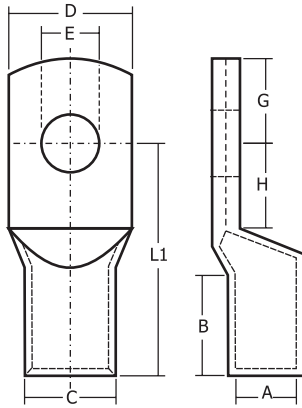

45° ANGLE TYPE

90° ANGLE TYPE

* Electrolytic High Conductivity Copper
* Electro Tinned Plated

Product Ref.	Conductor Size mm ²	Stud Hole	Dimensions mm							
			A	B	D	E	C	G	H	L1
DIN 150-10	150	M-10	17.0	35	34	10.5	23.5	15	16	78
DIN 150-12	150	M-12			34	13.0		16	17	
DIN 150-14	150	M-14			34	15.0		19	20	
DIN 150-16	150	M-16			34	17.0		19	20	
DIN 150-20	150	M-20			40	21.0		21	22	
DIN 185-10	185	M-10	19.0	40	37	10.5	25.5	15	16	82
DIN 185-12	185	M-12			37	13.0		16	17	
DIN 185-14	185	M-14			37	15.0		19	20	
DIN 185-16	185	M-16			37	17.0		19	20	
DIN 185-20	185	M-20			40	21.0		21	22	
DIN 240-12	240	M-12	21.5	40	42	13.0	29.0	16	17	92
DIN 240-14	240	M-14			42	15.0		19	20	
DIN 240-16	240	M-16			42	17.0		19	20	
DIN 240-20	240	M-20			42	21.0		21	22	
DIN 300-14	300	M-14	24.5	50	48	15.0	32	19	22	100
DIN 300-16	300	M-16			48	17.0		19	22	
DIN 300-20	300	M-20			48	21.0		22	22	
DIN 400-14	400	M-14	27.5	70	55	15.0	38.5	25	25	115
DIN 400-16	400	M-16			55	17.0		25	25	
DIN 400-20	400	M-20			55	21.0		25	25	
DIN 500-16	500	M-16	31.0	70	60	17.0	42	25	25	125
DIN 500-20	500	M-20			60	21.0		25	25	
DIN 625-16	625	M-16	34.5	80	60	17.0	44	25	25	135
DIN 625-20	625	M-20			60	21.0		25	25	
DIN 800-16	800	M-16	40.0	100	75	17.0	52	30	30	165
DIN 800-20	800	M-20			75	21.0		30	30	
DIN 1000-21	1000	M-21	44.0	100	85	21.0	58	25	20	165

MATERIAL - EC GRADE COPPER IS -191

TOLERANCE=± 5%

FINISH - ELECTRO TINNED

WE RESERVE THE RIGHTS AT ANY TIME TO MAKE ANY SPECIFICATION OR DIMENSIONAL CHANGES DEEMED NECESSARY TO ENSURE ADVANCEMENT IN THE DESIGN OR MANUFACTURE OF ANY PRODUCT

- * Electrolytic High Conductivity Copper
- * Electro Tinned Plated
- * Copper Finish on Request

Product Ref.	Stud Hole	Dimensions mm				
		I	W	C	E	L
CHVT 25	M 8	6.8	14.0	17	8.4	57
CHVT 25	M 10	6.8	18.0	21	10.5	51
CHVT 25	M 12	6.8	21.0	30	13.2	64
CHVT 35	M 12	8.2	19.0	26	13.2	53
CHVT 35	M 16	8.2	26.0	36	17.0	68
CHVT 50	M 10	9.5	20.0	26	10.5	55
CHVT 50	M 12	9.5	20.0	26	13.2	55
CHVT 50	M 16	9.5	26.0	36	17.0	68
CHVT 70	M 12	11.2	21.0	26	13.2	70
CHVT 70	M 16	11.0	30.0	36	17.0	70.2
CHVT 95	M 12	13.5	25.0	26	13.2	78
CHVT 95	M 14	12.0	29.0	34	15.0	79
CHVT 120	M 12	15.0	28.0	26	13.2	82
CHVT 120	M 14	15.0	31.0	34	15.0	85
CHVT 150	M 12	16.5	30.0	30	13.2	98
CHVT 150	M 14	16.5	32.0	34	15.0	85
CHVT 180	M 14	17.0	32.5	34	15.0	85
CHVT 240	M 14	19.2	43.0	34	15.0	91
CHVT 300	M 12	23.5	44.0	36	12.0	106
CHVT 300	M 14	23.7	44.0	34	15.0	89
CHVT 400	M 14	27.0	51.0	41	15.0	121
CHVT 400	M 16	26.5	50.1	41	17.0	140
CHVT 400	M 20	27.0	51.0	47	21.0	123
CHVT 500	M 16	30.0	56.0	41	17.0	147
CHVT 500	M 20	30.3	56.5	47	21.0	130
CHVT 630	M 16	35.0	62.0	41	17.0	159
CHVT 630	M 20	33.4	61.5	47	21.0	142

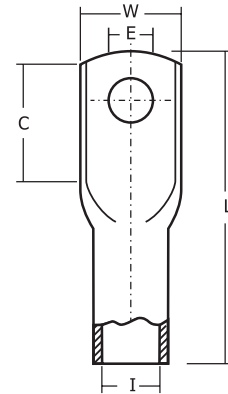

CRIMP TERMINALS Copper Connectors

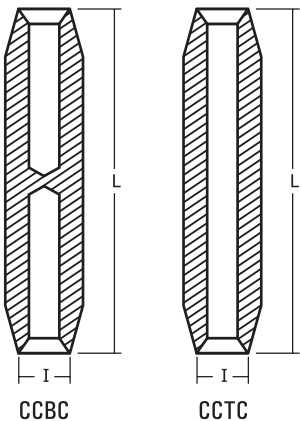

- * Electrolytic High Conductivity Copper
- * Electro Tinned Plated
- * Copper Finish on Request

Product Ref.	Dimensions mm		Product Ref.	Dimensions mm	
	I	L		I	L
CCBC/ CCTC 25	6.8	60	CCBC/ CCTC 150 L	16.5	80
CCBC/ CCTC 35	8.2	60	CCBC/ CCTC 185	17.0	100
CCBC/ CCTC 50	8.7	60	CCBC/ CCTC 240	19.2	100
CCBC/ CCTC 50 L	9.5	60	CCBC/ CCTC 300	21.5	100
CCBC/ CCTC 70	11.0	70	CCBC/ CCTC 300L	23.7	100
CCBC/ CCTC 95	12.0	80	CCBC/ CCTC 400	27.0	120
CCBC/ CCTC 95L	13.5	80	CCBC/ CCTC 500	30.3	118
CCBC/ CCTC 150	15.0	80	CCBC/ CCTC 630	33.4	130

MATERIAL-EC GRADE COPPER IS -191

TOLERANCE=± 5%

FINISH - ELECTRO TINNED

WE RESERVE THE RIGHTS AT ANY TIME TO MAKE ANY SPECIFICATION OR DIMENSIONAL CHANGES DEEMED NECESSARY TO ENSURE ADVANCEMENT IN THE DESIGN OR MANUFACTURE OF ANY PRODUCT

LUGS SYSTEM

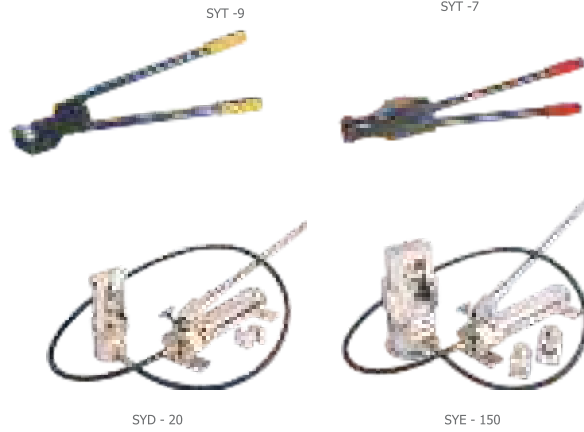
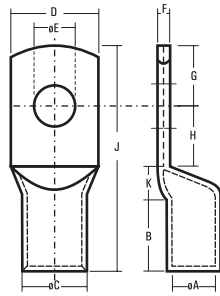

WE RESERVE THE RIGHTS AT ANY TIME TO MAKE ANY SPECIFICATION OR DIMENSIONAL CHANGES DEEMED NECESSARY TO ENSURE ADVANCEMENT IN THE DESIGN OR MANUFACTURE OF ANY PRODUCT

MM ²	E Bolt MMø	øA	øC	D	F	B	K	G-H	J	Dowell's CAT. No.	SYB 95	SYD 20A	SYE 150A	SYT-7	SYT -102 R	STD PKG
2.5	M3	2.0	5.5	7.0	3.5	7	3	8	18	ALS-151	SYT -17	SYB - 95	SYE 150A	SYT-7	SYT -102 R	200
	M3.5	2.6	5.5	7.0	2.9	7	3	8	18	ALS-309						200
4.0	M4	2.9	5.5	7.0	2.6	7	3	8	18	ALS-155	SYA - 427	SYB - 95	SYE 150A	SYT-7	SYT -102 R	200
	M5	2.9	5.5	12.0	1.2	7	4	13	24	ALS-317						200
6.0	M5	3.5	5.5	8.0	2.0	7	4	13	24	ALS-158	SYT - 2	SYB - 95	SYE 150A	SYT-7	SYT -102 R	200
	M6	3.5	5.5	12.0	1.1	7	4	13	24	ALS-313						200
10	M6	4.4	7.4	10.0	2.8	9	4	17	30	ALS-214	JBR-1					200
	M8	4.4	7.4	15.0	1.8	9	4	17	30	ALS-215	JBR-1					200
16	M6	5.4	8.3	11.0	2.9	13	4	20	37	ALS-252	JBR-2					200
	M8	5.4	8.3	11.0	2.9	13	4	20	37	ALS-216	JBR-2					200
25	M10	7.0	10.0	18.0	1.8	16	7	21	44	ALS-217	JBR-4					100
	M8	7.0	10.0	14.0	3.0	16	7	21	44	ALS-218	JBR-4					100
35	M10	8.0	10.8	15.0	2.8	18	7	22	47	ALS-219	JBR-5					100
	M12	8.0	10.8	20.0	2.1	18	7	22	47	ALS-222	JBR-5					100
50	M8	9.3	13.0	18.0	3.7	22	8	24	54	ALS-255	JBR-7				HY-267	100
	M10	9.3	13.0	23.0	2.8	22	8	24	54	ALS-312	JBR-7				HY-267	100
70	M12	11.6	16.0	23.0	2.8	26	8	26	60	ALS-224	JBR-9				HY-268	50
	M8	11.6	16.0	22.0	4.4	26	8	26	60	ALS-256	JBR-9				HY-268	50
95	M10	12.9	17.1	25.0	4.2	28	8	28	64	ALS-225	JBR-10				HY-269	50
	M12	12.9	17.1	25.0	4.2	28	8	28	64	ALS-228	JBR-10				HY-269	50
120	M16	14.8	19.6	28.0	4.8	32	11	30	73	ALS-229	JBR-11	JDR-11	JER-11	JEK-402	HY-270	30
	M10	14.8	19.6	28.0	4.8	32	11	30	73	ALS-257	JBR-11	JDR-11	JER-11	JEK-402	HY-270	30
150	M12	16.1	21.2	31.0	5.1	34	11	34	79	ALS-230	JBR-11	JDR-12	JER-12	JEK- 403	HY-271	20
	M16	16.1	21.2	31.0	5.1	34	11	34	79	ALS-231	JBR-11	JDR-12	JER-12	JEK- 403	HY-271	20
185	M10	18.0	23.7	34.0	5.7	36	12	36	84	ALS-232	JBR-11	JDR-13	JER-13	JEK-404	HY-272	10
	M12	18.0	23.7	34.0	5.7	36	12	36	84	ALS-311	JBR-11	JDR-13	JER-13	JEK-404	HY-272	10
225	M16	20.6	27.0	39.0	6.4	40	14	40	94	ALS-234	JBR-11	JDR-13	JER-14	JEK-405	HY-273	10
	M12	20.6	27.0	39.0	6.4	40	14	40	94	ALS-235	JBR-11	JDR-13	JER-14	JEK-405	HY-273	10
240	M16	22.0	28.0	40.0	6.0	44	14	44	102	ALS-236	JBR-11	JDR-14	JER-15	JEK-406	HY-273	10
	M12	22.0	28.0	40.0	6.0	44	14	44	102	ALS-237	JBR-11	JDR-14	JER-15	JEK-406	HY-273	10
300	M16	24.0	31.0	45.7	7.0	47	14	54	115	ALS-300	JBR-11	JDR-150	JER-16	JEK-407	HY-274	10
	M20	24.0	31.0	45.7	7.0	47	14	54	115	ALS-259	JBR-11	JDR-150	JER-16	JEK-407	HY-274	10
400	M20	28.0	36.0	51.0	8.0	56	13	61	130	ALS-260			JER-18	JEK-277	HY-275	5
500	M20	30.0	41.0	58.0	11.0	60	15	65	140	ALS-296			JER-20		HY-279	5
630	M20	35.0	46.0	66.0	11.0	69	16	69	154	ALS-261			JER-21		HY-280	5
800	M20	39.0	51.0	73.0	12.0	77	25	78	180	ALS-318			JER-27			5
1000	M20	43.5	57.0	81.0	13.5	100	30	90	220	ALS-319			JER-29			4

MATERIAL-ELECTROLYTIC ALUMINIUM IS 5082/IS 8309

TOLERANCE=± 5%

FINISH : NATURAL

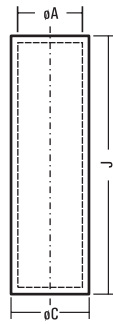

WE RESERVE THE RIGHTS AT ANY TIME TO MAKE ANY SPECIFICATION OR DIMENSIONAL CHANGES DEEMED NECESSARY TO ENSURE ADVANCEMENT IN THE DESIGN OR MANUFACTURE OF ANY PRODUCT

MM ²	øA	øC	J	Dowell's CAT. No.	SYB 95	SYD 20A	SYE 150A	SYT 7	SYT 9	SYT 102 R	STD PKG
2.5	2.6	5.5	16	ALS-6	SYA-427						200
4.0	2.9	5.5	16	ALS-5	SYT-17						200
6.0	3.5	5.5	16	ALS-13	SYT-2				6		200
10	4.4	7.4	20	ALS-14	JBR-1				10		200
16	5.4	8.3	26	ALS-4	JBR-2				16		200
25	7.0	10.0	35	ALS-3	JBR-4				25		100
35	8.0	10.8	40	ALS-2	JBR-5				35		100
50	9.3	13.0	45	ALS-12	JBR-7				50	HY-267	100
70	11.6	16.0	55	ALS-1	JBR-9					HY-268	50
95	12.9	17.1	60	ALS-15	JBR-10					HY-269	50
120	14.8	19.6	65	ALS-9	JBR-11	JDR-11	JER-11	JEK-402		HY-270	30
150	16.1	21.2	70	ALS-10		JDR-12	JER-12	JEK-403		HY-271	20
185	18.0	23.7	75	ALS-11		JDR-13	JER-13	JEK-404		HY-272	20
225	20.6	27.0	85	ALS-147		JDR-14	JER-14	JEK-405		HY-273	10
240	22.0	28.0	90	ALS-16		JDR-15	JER-15	JEK-406		HY-273	10
300	24.0	31.0	100	ALS-17		JDR-16	JER-16	JEK-407		HY-274	10
400	28.0	36.0	115	ALS-18			JER-18	JEK-277		HY-275	5
500	30.0	41.0	125	ALS-19			JER-20			JEM-279	5
630	35.0	46.0	140	ALS-20			JER-21				5
800	39.0	51.0	160	ALS-148			JER-27				5
1000	43.5	57.0	210	ALS-149			JER-29				4

MATERIAL-ELECTROLYTIC ALUMINIUM IS 5082

TOLERANCE=± 5%

FINISH : NATURAL

SOLDERING TYPE TUBE TERMINALS

AMPS	øE	øA	øC	D	F	B	K	H	G	J	Dowell's CAT. No.	STD. PKG.
60	6.4	8.1	9.5	14	1.4	14	4	9	9	36	DEW-203	100
100	9.5	10.9	12.7	19	1.8	19	8	11	11	49	DEW-204	50
150	9.5	13.9	15.9	24	2.0	23	8	13	13	57	DEW-205	30
200	12.7	16.6	19.0	28	2.4	27	11	14	14	66	DEW-206	20
300	12.7	19.0	22.2	33	3.2	28	13	20	19	80	DEW-207	20
400	15.9	22.2	25.4	38	3.2	32	15	21	21	89	DEW-208	10
500	19.0	25.4	28.6	43	3.2	38	17	25	25	105	DEW-209	10
600	19.0	27.8	31.8	47	4.0	44	17	27	27	115	DEW-210	10

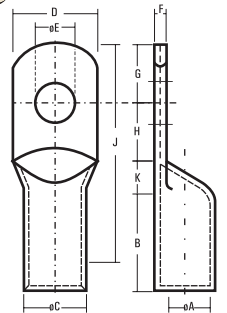

FINISH - ELECTRO TINNED

1) Terminals and splices covered in this catalogue are of standard series only. Please refer us for your tailor made requirements such a specific stud holes, Palm and Barrel lengths.

2) Dowell's products available for Railways duly approved by R.D.S.O., C.L.W., D.L.W., I.C.F. etc

MATERIAL-EC GRADE COPPER IS -191

TOLERANCE=± 5%

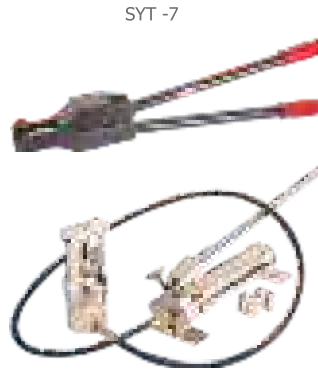
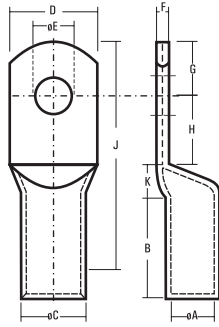

WE RESERVE THE RIGHTS AT ANY TIME TO MAKE ANY SPECIFICATION OR DIMENSIONAL CHANGES DEEMED NECESSARY TO ENSURE ADVANCEMENT IN THE DESIGN OR MANUFACTURE OF ANY PRODUCT

MM ²	E Bolt MMø	øA	øC	D	F	B	K	G-H	J	Dowell's CAT. No.	SYB 95	SYD 20A	SYE 150A	SYT 7	SYT 9	SYT-102 R	STD PKG
2.5	M3	2.0	5.5	7.0	3.5	10.5	3	8	21.5	ALS-551	SYT-17	SYB-95	SYA-427	SYT-2	SYT 102 R		200
	M3.5	2.6			2.9					ALS-509							
4.0	M4	2.9	5.5	7.0	2.6	10.5	3	8	21.5	ALS-555	SYB-95	SYA-427	SYT-2	SYT 102 R		200	
	M5	5.5	12.0	1.2	10.5	4	13	27.5	ALS-517								
6.0	M5	3.5	5.5	8.0	2.0	10.5	4	13	27.5	ALS-558	SYB-95	SYA-427	SYT-2	SYT 102 R		200	
	M6	12.0	1.1	10.5	4	13	27.5	ALS-513									
10	M6	4.4	7.4	10.0	2.8	13.5	4	17	34.5	ALS-514	JBR-1			10		200	
	M8	15.0	1.8	13.5	4	17	34.5	ALS-515									
16	M6			11.0	2.9					ALS-552	JBR-2			16		200	
	M8	5.4	8.3	11.0	2.9	19.5	4	20	43.5	ALS-516							
25	M10			18.0	1.8					ALS-617	JBR-4			25		100	
	M8	7.0	10.0	20.0	1.7	24	7	21	52	ALS-518							
35	M10	7.0	10.0	20.0	1.7	24	7	21	52	ALS-519	JBR-5			35		100	
	M12	20.0	1.7	24	7	21	52	ALS-520									
50	M8	8.0	10.8	15.0	2.8	27	7	22	56	ALS-521	JBR-7			50	HY-267	100	
	M10	9.3	13.0	23.0	2.8	33	8	24	65	ALS-512							
70	M12			23.0	2.8					ALS-524	JBR-9				HY-268	50	
	M8	11.6	16.0	22.0	4.4	39	8	26	73	ALS-556							
95	M10									ALS-525	JBR-10				HY-269	50	
	M12	12.9	17.1	25.0	4.2	42	8	28	78	ALS-526							
120	M16									ALS-527	JBR-11	JDR-11	JER-11	JEK-402	HY-270	30	
	M10	14.8	19.6	28.0	4.8	48	11	30	89	ALS-530							
150	M12	16.1	21.2	31.0	5.1	51	11	34	96	ALS-531	JDR-12	JER-12	JEK-403	HY-271	20		
	M16	21.2	31.0	5.1	51	11	34	96	ALS-532								
185	M10									ALS-533	JDR-13	JER-13	JEK-404	HY-272	10		
	M12	18.0	23.7	34.0	5.7	54	12	36	102	ALS-511							
225	M16									ALS-534	JDR-14	JER-14	JEK-405	HY-273	10		
	M12	20.6	27.0	39.0	6.4	60	14	40	114	ALS-535							
240	M16									ALS-536	JDR-15	JER-15	JEK-406	HY-273	10		
	M12	22.0	28.0	40.0	6.0	66	14	44	124	ALS-537							
300	M16									ALS-500	JDR-16	JER-16	JEK-407	HY-274	10		
	M20	24.0	31.0	45.7	7.0	70.5	14	54	138.5	ALS-559							
400	M20	28.0	36.0	51.0	8.0	84	13	61	158	ALS-560		JER-18	JEK-277	HY-275	5		
500	M20	30.0	41.0	58.0	11.0	90	15	65	170	ALS-596		JER-20		JEM-279	5		
630	M20	35.0	46.0	66.0	11.0	103.5	16	69	188.5	ALS-561		JER-21			5		
800		39.0	51.0	73.0	12.0	115.5	25	78	218.5	ALS-618		JER-27			5		
1000		43.5	57.0	81.0	13.5	150	30	90	270	ALS-619		JER-29			4		

MATERIAL-ELECTROLYTIC ALUMINIUM IS 5082/IS 8309

TOLERANCE=± 5%

FINISH : NATURAL

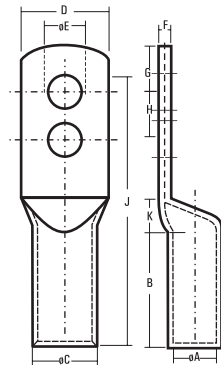

SYT - 7

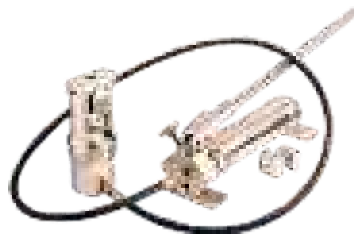

SYD - 20A

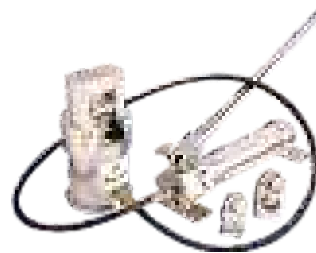

SYE - 150A

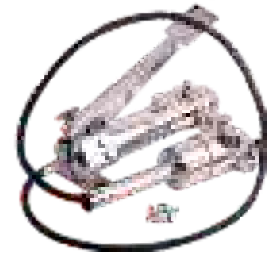

SYT 102 R

MM ²	E Bolt MMø	øA	øC	D	F	B	K	G-H	J	Dowell's CAT. No.	SYD 20A	SYE 150 A	SYE 150 B	SYT 7	SYT-102 R
150	M16	16.1	21.2	30.5	5.2	70.5	10.0	55.4	151.5	ALS-701	JDR-12	JER-12	JEA-150	JEK-403	JEM-271
240	M12	21.5	28	41.0	6.0	64.0	14.0	62.3	164.8	ALS-702	JDR-15	JER-15	JEA-240	JEK-406	JEM-273
300	M16	24	31	45.0	7.0	99.5	16.2	77.6	211.5	ALS-703	JDR-16	JER-16	JEA-300	JEK-407	JEM-274
300	M20	24	31	45.0	7.0	99.5	16.2	77.6	211.5	ALS-704					
300	M16	25	32	46.3	7.0	105	14.0	70.0	218.0	ALS-705					
630	M20	36	46	65.9	10.0	100	16.0	104	255.0	ALS-706		JER-21	JEA-630		

ALUMINIUM FERRULES FOR ALUMINIUM XLPE CONDUCTORS

dowells cat No	Conductor Size mm ²	øA	øC	J
ALS-XL1	25	7.2	9.6	82
ALS-XL2	35	8.3	11.1	90
ALS-XL3	50	10.1	13.5	100
ALS-XL4	70	10.2	14.5	104
ALS-XL5	95	12.0	16.9	108
ALS-XL6	120	13.7	19.0	112
ALS-XL7	150	15.1	21.2	116
ALS-XL8	185	16.6	23.9	128
ALS-XL9	225	18.6	26.1	136
ALS-XL10	240	19.3	27.2	148
ALS-XL11	300	21.8	30.2	160
ALS-XL12	400	25.0	34.8	182
ALS-XL13	500	28.2	39.1	190
ALS-XL14	630	31.7	44.4	200
ALS-XL15	800	35.7	49.5	225
ALS-XL16	1000	41.0	56.0	250

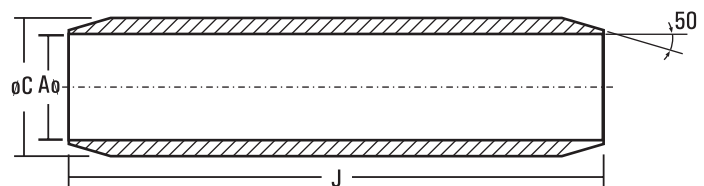

MATERIAL-ELECTROLYTIC ALUMINIUM IS 5082

TOLERANCE=± 5%

FINISH : NATURAL

WE RESERVE THE RIGHTS AT ANY TIME TO MAKE ANY SPECIFICATION OR DIMENSIONAL CHANGES DEEMED NECESSARY TO ENSURE ADVANCEMENT IN THE DESIGN OR MANUFACTURE OF ANY PRODUCT

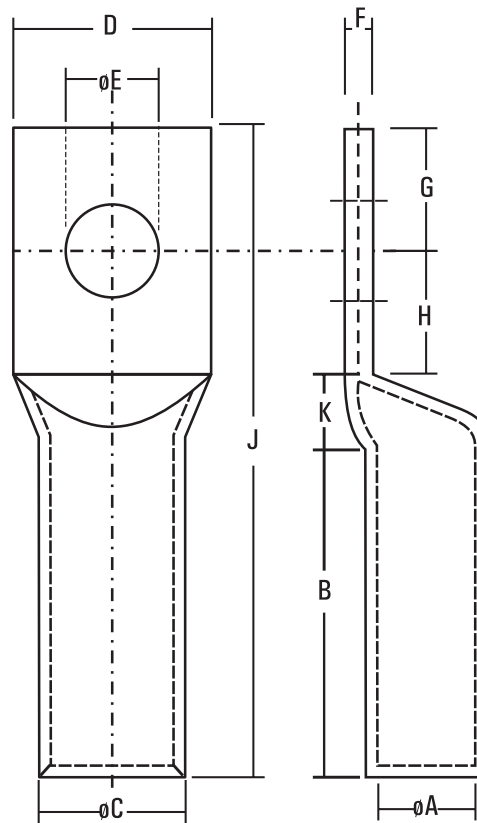

WE RESERVE THE RIGHTS AT ANY TIME TO MAKE ANY SPECIFICATION OR DIMENSIONAL CHANGES DEEMED NECESSARY TO ENSURE ADVANCEMENT IN THE DESIGN OR MANUFACTURE OF ANY PRODUCT

Dowell's Cat No.	Size mm ²	ø E	ø A	ø C	D	F	B	K	H	G	J
ALS-XL17	25	8.2	7.2	9.6	14.0	2.4	41	7	12	9	69
ALS-XL18	35	8.2	8.3	11.1	16.0	2.8	50	7	11	11	79
ALS-XL19	50	10.2	10.1	13.5	19.5	3.4	49	8	13	11	81
ALS-XL20	70	10.2	10.2	14.5	20.5	4.3	62	8	13	13	96
ALS-XL21	95	12.7	12.0	16.9	23.5	4.9	73	8	14	14	109
ALS-XL22	120	12.7	13.7	19.0	26.5	5.3	73	11	15	15	114
ALS-XL23	150	12.7	15.1	21.1	29.5	6.1	83	11	17	17	128
ALS-XL24	185	12.7	16.6	23.9	33.0	7.3	83	12	18	18	131
ALS-XL25	225	12.7	18.6	26.1	36.0	7.5	86	14	20	20	140
ALS-XL26	240	12.7	19.3	27.2	37.5	7.9	86	14	22	22	144
ALS-XL27	300	20.3	21.8	30.2	42.0	8.4	89	14	27	27	157
ALS-XL28	400	20.3	25.0	34.8	48.0	9.8	113	13	30	30	187
ALS-XL29	500	20.3	28.2	39.1	54.0	10.9	125	15	32	32	205
ALS-XL30	630	20.3	31.7	44.4	61.0	12.7	140	16	34	34	225
ALS-XL31	800	20.3	35.7	49.5	68.0	13.8	147	25	39	39	250
ALS-XL32	1000	20.3	41.0	56.0	77.5	15.0	160	30	45	45	280

MATERIAL-ELECTROLYTIC ALUMINIUM IS 5082

TOLERANCE=± 5%

FINISH : NATURAL

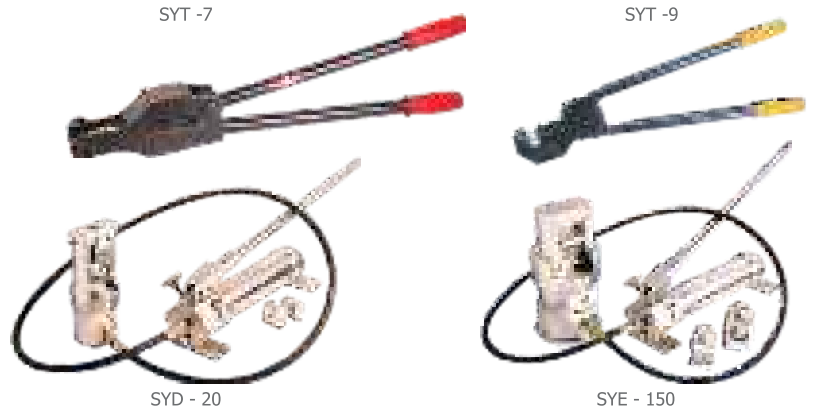
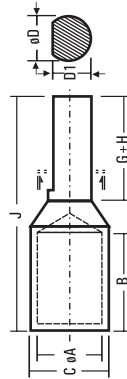

WE RESERVE THE RIGHTS AT ANY TIME TO MAKE ANY SPECIFICATION OR DIMENSIONAL CHANGES DEEMED NECESSARY TO ENSURE ADVANCEMENT IN THE DESIGN OR MANUFACTURE OF ANY PRODUCT

mm ²	Ø A	Ø C	Ø D	D-1	B	K	G+H	J	Dowell's Cat No.	RECOMMENDED TOOLS & DIES						STD PKG	
										SYB 95	SYD 20A	SYE 150A	SYT 7	SYT 9	SYT-102 R		
2.5	2.0	5.5	4.5	4.0	7	4	10	21	AWP-1	SYT -17					200		
	2.6		3.8	3.3		4	10		AWP-7								
4.0	2.9	5.5	4.5	4.0	7	4	10	21	AWP-15	SYA - 427					200		
			3.8	3.3		4	10		AWP-16								
6.0	3.5	5.5	4.5	4.0	7	4	10	21	AWP-17	SYT - 2					200		
			3.8	3.3		4	10		AWP-18								
10	3.8	7.4	4.5	4.0	9	4	10	23	AWP-19	JBR-1					10		
	3.8		3.8	3.3		9	4		10							23	AWP-20
	4.4		4.5	4.0		9	4		10							23	AWP-21
	4.4		3.8	3.3		9	4		10							23	AWP-22
16	5.4	8.3	6.0	5.5	13	5	15	33	AWP-23	JBR-2					16		
			6.0	5.5		13	5		20							38	AWP-24
			3.8	3.3		13	5		13							31	AWP-2
25	7.0	10.0	6.0	5.5	16	5	15	36	AWP-25	JBR-4					25		
			7.5	6.5		16	5		20							41	AWP-3
35	8.0	10.8	7.5	6.5	18	5	20	43	AWP-4	JBR-5					35		
			7.5	6.5		22	5		20							47	AWP-26
50	9.3	13.0	7.5	6.5	22	5	20	47	AWP-26	JBR-7					50		
	10.4		14.0	14		13	22		7							24	53
70	11.6	16.0	7.5	6.5	26	5	20	51	AWP-27	JBR-9					50		
			11.5	10.5		5	25		56							AWP-6	HY-268
			11.5	10.5		5	32		63							AWP-28	
			11.5	10.5		6	25		59							AWP-29	
95	12.9	17.1	15.6	14.0	28	6	27	61	AWP-8	JBR-10					50		
			7.5	6.5		6	22		56							AWP-31	HY-269
			12.8	11.8		6	32		66							AWP-32	
			11.5	10.5		6	25		63							AWP-33	
120	14.8	19.6	7.5	6.5	32	6	22	60	AWP-34	JBR-11					30		
			11.5	10.5		6	32		70							AWP-35	HY-270
			15.6	14		6	32		70							AWP-36	
			11.5	10.5		6	25		63							AWP-33	
150	16.1	21.2	15.6	14	34	6	32	72	AWP-10	JBR-12					20		
			11.5	10.5		6	32		72							AWP-37	HY-271
185	18.0	23.7	15.6	14	36	6	32	74	AWP-30	JBR-13					10		
			11.5	10.5		6	32		74							AWP-38	HY-272
225	20.6	27.0	15.6	14	40	8	32	80	AWP-39	JBR-14					10		
			21	18		8	42		90							AWP-46	HY-273
			16	15		8	42		90							AWP-42	
240	22.0	28.0	16	15	44	8	42	94	AWP-44	JBR-15					10		
			15.6	14		8	32		84							AWP-43	HY-273
300	24.0	31.0	16	15	47	8	42	97	AWP-45	JBR-16					10		
			15.6	14		8	32		87							AWP-47	HY-274

MATERIAL-ELECTROLYTIC ALUMINIUM IS 5082

TOLERANCE=± 5%

FINISH : NATURAL

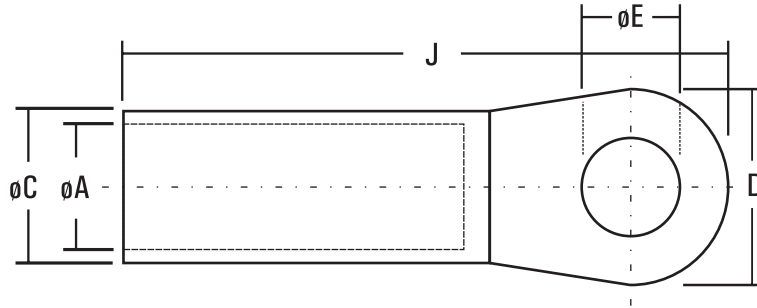

WE RESERVE THE RIGHTS AT ANY TIME TO MAKE ANY SPECIFICATION OR DIMENSIONAL CHANGES DEEMED NECESSARY TO ENSURE ADVANCEMENT IN THE DESIGN OR MANUFACTURE OF ANY PRODUCT

mm ²		Dowell's Cat No.	Ø E	Ø A	Ø C	D	J
S	F						
16	----	ALS-D-01	8.5				
		ALS-D-02	10.5	5.6	12	20	63
25	16	ALS-D-03	8.5	6.0	12	20	63
		ALS-D-04	10.5	6.0	12	20	63
		ALS-D-05	8.5				
35	25	ALS-D-06	10.5	6.8	12	25	65.5
		ALS-D-07	13.0				
		ALS-D-08	8.5				
50	35	ALS-D-09	10.5	8.3	14	25	74.5
		ALS-D-10	13.0				
		ALS-D-11	8.5				
70	50	ALS-D-12	10.5	10.0	16	25	74.5
		ALS-D-13	13.0				
		ALS-D-14	10.5				
95	70	ALS-D-15	13.0	11.5	18	25	84.5
		ALS-D-16	10.5				
120	95	ALS-D-17	13.0	13.2	22	25	87.5
		ALS-D-18	17.0				
150	120	ALS-D-19	13.0	14.7	22	30	95
		ALS-D-20	17.0				

mm ²		Dowell's Cat No.	Ø E	Ø A	Ø C	D	J
S	F						
		ALS-D-21	13.0			30	105
185	150	ALS-D-22	17.0	16.3	25	30	105
		ALS-D-23	21.0			38	109
		ALS-D-24	10.5			30	106
240	185	ALS-D-25	13.0	18.3	28	30	106
		ALS-D-26	17.0			30	106
		ALS-D-27	21.0			38	110
		ALS-D-28	10.5				
300	240	ALS-D-29	13.0	21.0	32	38	122
		ALS-D-30	17.0				
		ALS-D-31	21.0				
		ALS-D-32	17.0	23.3	34	38	122
--	300	ALS-D-33	21.0				
		ALS-D-34	17.0	26.0	38	38	135
--	400	ALS-D-35	21.0				
		ALS-D-36	17.0	29.0	44	44	144
		ALS-D-37	21.0				
400	400	ALS-D-38	17.0	28.0	38	38	135
		ALS-D-39	21.0				
500	500	ALS-D-40	17.0	31.0	44	44	144
		ALS-D-41	21.0				

COMPRESSION TYPE ALUMINIUM CONNECTORS TO DIN 57295

mm ²		Dowell's Cat No.	Ø A	Ø C	Ø C
S	F				
35	25	ALSD-D-51	7.0	12	90
50	35	ALSD-D-52	8.3	14	90
70	50	ALSD-D-53	10.0	16	90
95	70	ALSD-D-54	11.3	18	95
120	95	ALSD-D-55	13.5	22	100
150	120	ALSD-D-56	14.8	22	105
185	150	ALSD-D-57	16.5	25	105
240	185	ALSD-D-58	18.3	28	125
300	240	ALSD-D-59	21.0	32	125
--	300	ALSD-D-60	23.4	34	125
--	400	ALSD-D-61	26.0	38	150
--	500	ALSD-D-62	29.0	44	170

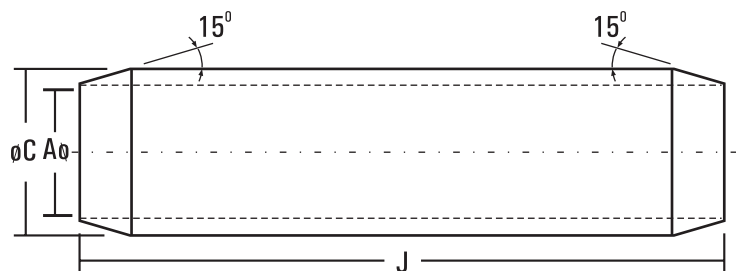

MATERIAL-ELECTROLYTIC ALUMINIUM IS 5082

TOLERANCE=± 5%

FINISH : NATURAL

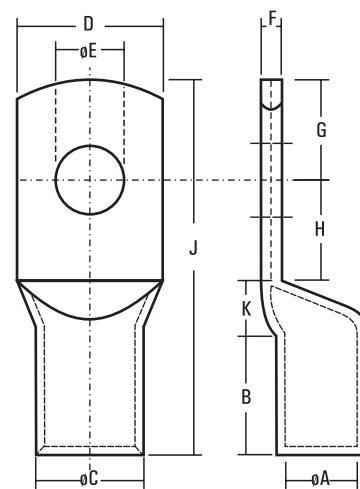

Dowell's Compression type Bi-metallic tubular terminal ends are basically made out of electrolytic grade aluminium conforming to IS 5082 Grade T1E. These aluminium terminals are first plated with copper and then electro-tinned.

The Bi-metallic terminal end barrel is filled with Dowell's corrosion inhibiting compound duly factory sealed with caps. This corrosion inhibiting compound is a mixture of fine metallic zinc particles suspended in a high temperature grease, which is conductive and acts as electrical bridge between conductor strands. This compound plays main role in breaking the oxide film which can form quickly on the surface of aluminium when exposed to atmosphere.

These Bi-metallic terminals are mainly used to terminate on copper bus-bars. Whenever aluminium links terminated on to copper or copper based alloy terminals without suitable plating, results in the corrosion of the joint over a period leading to higher joint resistance. BI-METALLIC terminals are found most reliable and suitable for such connections.

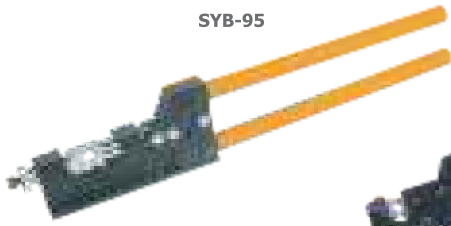

SYB-95



SYT-9



SYT-7

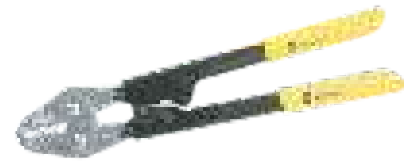

SYT-2

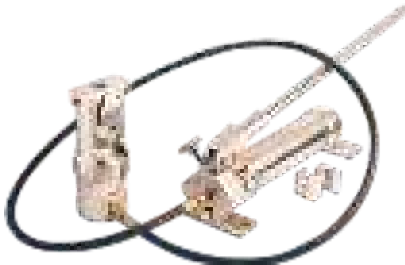

SYD-20



SYE-150

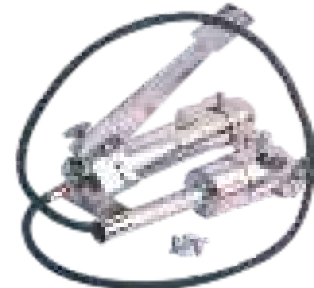

SYT-102

WE RESERVE THE RIGHTS AT ANY TIME TO MAKE ANY SPECIFICATION OR DIMENSIONAL CHANGES DEEMED NECESSARY TO ENSURE ADVANCEMENT IN THE DESIGN OR MANUFACTURE OF ANY PRODUCT

MM ²	E Bolt MMØ	øA	øC	D	F	B	K	G+H	J	Dowell's CAT. No.	SYB 95	SYD 20A	SYE 150A	SYT 7	SYT 9	SYT - 102 R	STD PKG
10	M 6	4.4	7.4	10.0	2.8	9	4	17	30	BL-1	JBR-1				10		200
	M 8			15.0	1.8					BL-2							
16	M 6	5.4	8.3	11.0	2.9	13	4	20	37	BL-3	JBR-2				16		200
	M 8			11.0	2.9					BL-4							
25	M8	7.0	10.0	14.0	3.0	16	7	21	44	BL-5	JBR-4				25		100
	M10			20.0	1.7					BL-6							
35	M8	8.0	10.8	15.0	2.8	18	7	22	47	BL-7	JBR-5				35		100
	M10			20.0	2.1					BL-8							
50	M8	9.3	13.0	18.0	3.7	22	8	24	54	BL-9	JBR-7				50	HY-267	100
	M10			23.0	2.8					BL-10							
70	M10	11.6	16.0	22.0	4.4	26	8	26	60	BL-11	JBR-9					HY-268	50
	M12			22.0	4.4					BL-12							
95	M10	12.9	17.1	25.0	4.2	28	8	28	64	BL-13	JBR-10					HY-269	50
	M12			25.0	4.2					BL-14							
120	M10	14.8	19.6	28.0	4.8	32	11	30	73	BL-15	JBR-11	JDR-11	JER-11	JEK-402		HY-270	30
	M12			28.0	4.8					BL-16							
150	M12	16.1	21.2	31.0	5.1	34	11	34	79	BL-17	JDR-12	JER-12	JEK-403			HY-271	20
	M16			31.0	5.1					BL-18							
185	M12	18.0	23.7	34.0	5.7	36	12	36	84	BL-19	JDR-13	JER-13	JEK-404			HY-272	10
	M16			34.0	5.7					BL-20							
225	M12	20.6	27.0	39.0	6.4	40	14	40	94	BL-21	JDR-14	JER-14	JEK-405			HY-273	10
	M16			39.0	6.4					BL-22							
240	M12	22.0	28.0	40.0	6.0	44	14	44	102	BL-22	JDR-15	JER-15	JEK-406			HY-273	10
	M16			40.0	6.0					BL-23							
300	M16	24.0	31.0	45.7	7.0	47	14	54	115	BL-24	JDR-16	JER-16	JEK-407			HY-274	10
	M20			45.7	7.0					BL-25							
400	M20	28.0	36.0	51.0	8.0	56	13	61	130	BL-26			JER-18	JEK-277		HY-275	5
500	M20	30.0	41.0	58.0	11.0	60	15	65	140	BL-27			JER-20			JEM-279	5
630	M20	35.0	46.0	66.0	11.0	69	16	69	154	BL-28			JER-21				5
800		39.0	51.0	73.0	12.0	77	25	78	180	BL-29			JER-27				5
1000		43.5	57.0	81.0	13.5	100	30	90	220	BL-30			JER-29				4

MATERIAL-ELECTROLYTIC ALUMINIUM IS 5082 CU COATED

TOLERANCE=± 5%

FINISH : ELECTRO TINNED

* Electrolytic High Conductivity Copper

* Electro Tinned Plated

Product Ref.	Conductor Size mm ²	Dimensions mm		
		I	O	L
DIN 6	6	3.8	5.5	30
DIN 10	10	4.5	6.0	30
DIN 16	16	5.5	8.5	50
DIN 25	25	7	10.0	50
DIN 35	35	8.2	12.5	50
DIN 50	50	10	14.5	56
DIN 70	70	11.5	16.5	56
DIN 95	95	13.5	19.0	70
DIN 120	120	15.5	21.0	70
DIN 150	150	17	23.5	80
DIN 185	185	19	25.5	85
DIN 240	240	21.5	29.0	90
DIN 300	300	24.5	32.0	100
DIN 400	400	27.5	38.5	150
DIN 500	500	31	42.0	160
DIN 625	625	34.5	44.0	160
DIN 800	800	40	52.0	200
DIN 1000	1000	44	58.0	200

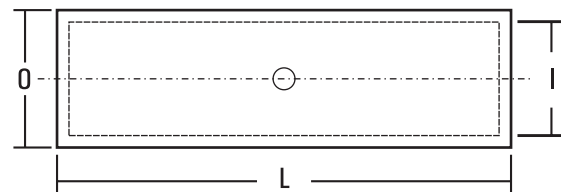

CRIMP TERMINALS

Butt Connectors Non Tension with Barrier : DIN 46267 TUBE DIMENSION IN ACCORDANCE WITH DIN 46267

* Electrolytic High Conductivity Copper

* Electro Tinned Plated

LEAKPROOF AGAINST OIL

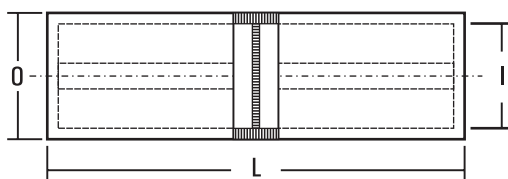

Product Ref.	Conductor Size mm ²	Dimensions mm		
		I	O	L
CB 16 S	16	5.5	8.5	50
CB 25 S	25	7	10.0	50
CB 35 S	35	8.2	12.5	50
CB 50 S	50	10	14.5	56
CB 70 S	70	11.5	16.5	56
CB 95 S	95	13.5	19.0	70
CB 120 S	120	15.5	21.0	70
CB 150 S	150	17	23.5	80
CB 185 S	185	19	25.5	85
CB 240 S	240	21.5	29.0	90
CB 300 S	300	24.5	32.0	100
CB 400 S	400	27.5	38.5	150
CB 500 S	500	31	42.0	160
CB 625 S	625	34.5	44.0	160

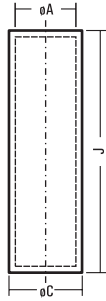

SYA - 427

SYT -17

SYT - 2



MM ²	øA	øC	J	Dowell's CAT. No.	RECOMM TOOLS	STD PKG
1.5	1.6	3.2	15	EH-453	SYA-427	200
2.5	2.4	4.0	15	EH-454	SYT-17	200
4.6	3.5	5.5	15	EH-455	SYT-2	200

COPPER INSULATED IN-LINE CONNECTORS

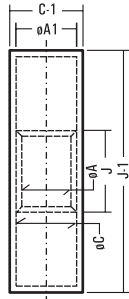

SYH-1614/ SYG-2216

SYI -1210/ SYO-1210



MM ²	øA	øC	øA-1	øC-1	J-1	J	Dowell's CAT. No.	RECOMM TOOLS	STD PKG
1.5	1.6	3.2	3.3	4.9	25	15	EH-463	SYG-2216/SYT-1546	200
2.5	2.4	4.0	4.1	5.5	25	15	EH-464	SYH-1614/SYT-1546	200
4.6	3.5	5.5	5.6	7.2	27	15	EH-465	SYI-1210/SYT-1546	200

END SEALING FERRULES

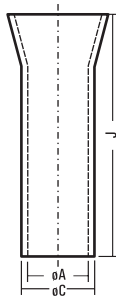
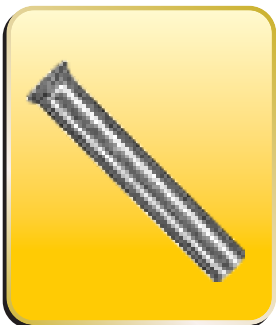

SYT- 52 M (0.5-6mm²)

SYT- 53 M (10- 35mm²)

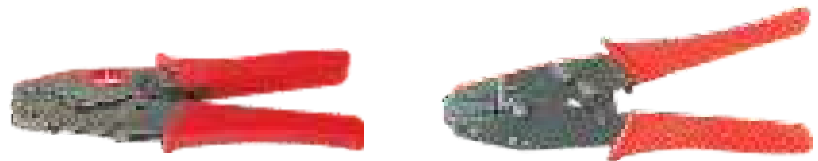

Area Mm ²	øA	øC	J	Dowell's CAT. No.	STD PKG	Area Mm ²	øA	øC	J	Dowell's CAT. No.	STD PKG			
0.5	1.0-1.1	1.4-1.5	6	EH-508	200	6.0	3.7-3.8	4.1-4.2	10	EH-518	200			
0.75	1.4-1.5	1.8-1.9	6	EH-509	200				12	EH-519				
1.0	1.6-1.7	2.0-2.1	6	EH-510	200	10	4.6-4.7	5.0-5.1	15	EH-520	200			
			10	EH-511					12	EH-521				
1.5	1.8-1.9	2.2-2.3	7	EH-512	200				12	EH-522		15	EH-522	200
			10	EH-513								18	EH-523	
2.5	2.3-2.4	2.7-2.8	7	EH-514	200				12	EH-524		12	EH-524	200
			12	EH-515								15	EH-525	
4.0	2.8-2.9	3.2-3.3	9	EH-516	200	16	5.9-6.0	6.3-6.4	15	EH-525	200			
			12	EH-517					18	EH-526				

MATERIAL -EC GRADE COPPER IS -191

TOLERANCE=± 5%

FINISH : ELECTRO TINNED

WE RESERVE THE RIGHTS AT ANY TIME TO MAKE ANY SPECIFICATION OR DIMENSIONAL CHANGES DEEMED NECESSARY TO ENSURE ADVANCEMENT IN THE DESIGN OR MANUFACTURE OF ANY PRODUCT

NON-INSULATED

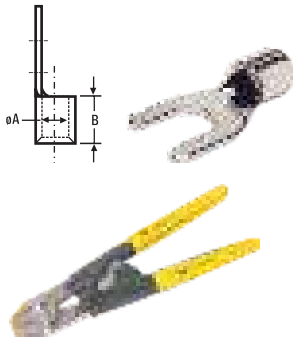

SYT-1546

INSULATED

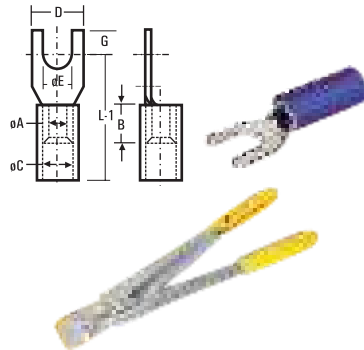

SYA - 427

PRE-INSULATED

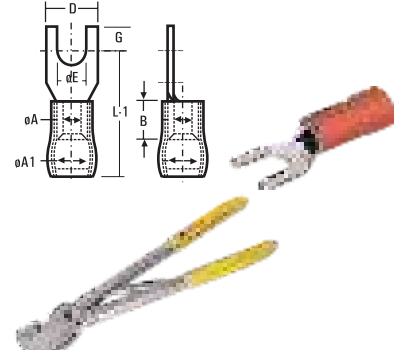

SYI -1210/ SYO-1210

Recomm Tools For RS	MM ²	E Bolt MMø	øA	D	B	G	L-1	Dowell's CAT. No.	øC	L-1	Dowell's CAT. No.	øA-1	L-1	Dowell's CAT. No.	Recommended Tools For RSI & PSD
SYT-17	1.5	M3.5	1.6	6.8	5	3.4	11.1	RS-7249	3.2	16.1	RSI-7926	3.6	16.1	PSD-7935	SYG-2216/SYT-1546
SYA-427	2.5	M 3.5	2.3	6.5	5	3.2	11.8	RS-7251	3.9	21.8	RSI-7928	4.4	16.8	PSD-7937	SYH-1614/SYT-1546
SYT-2	4-6	M 3	3.5	6.0	6	3.5	11.5	RS-7252	5.5	27.5	RSI-7930	6.4	20.5	PSD-7939	SYI-1210/SYT-1546
	4-6	M 3.5	3.5	6.0	6	4.0	11.0	RS-7253	5.5	27.0	RSI-7931	6.4	20.0	PSD-7940	
	2.5	M 5	2.6	10.6	6.2	6.2	12.4	RS-7280	4.6	20.0	RSI-7929	4.4	16.2	PSD-7938	

PIN TERMINALS

NON-INSULATED

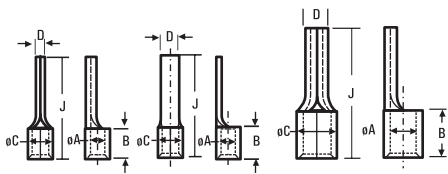

SYT -17

INSULATED

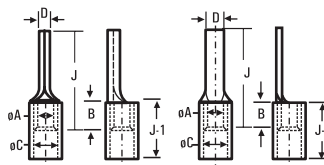

SYT - 2

PRE-INSULATED

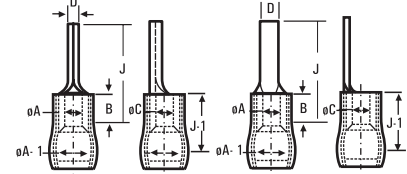

SYG - 2216 / SYH - 1614



SYI -1210/ SYO-1210



SYA - 427



SYB - 95

Tools Recomm For CP	MM ²	øA	øC	D	B	J	Type	Dowell's CAT. No.	J-1	Dowell's CAT. No.	øA-1	Dowell's CAT. No.	STD PKG	Recommended Tools For CPI & CPD
SYT-17	1.5	1.6	3.2	1.9	5	17	I	CP-9	10	CPI-17	3.6	CPD-26	200	SYG-2216
SYT-17	1.5	1.6	3.2	3.1	5	17	II	CP-35	10	CPI-40			200	
SYA-427	2.5	2.3	3.9	1.9	5	17	I	CP-1	10	CPI-18	4.4	CPD-27	200	SYH-1614
SYT-2	2.5	2.3	3.9	3.1	5	17	II	CP-2	10	CPI-19	4.4	CPD-28	200	SYI-1210
	4.0	2.9	4.9	2.7	6	20	I	CP-3	14	CPI-20	6.4	CPD-29	200	
SYT-2	6.0	3.6	5.6	2.7	6	20	I	CP-5					200	
	10	4.5	6.7	4.3	8	22	III	CP-7					200	SYB-95 JBR-1
	16	5.8	8.2	5.5	10	26	III	CP-8					200	SYB-95 JBR-2
SYB-95	25	7.5	11.1	7.0	11	32	III	CP-86					100	
	35	9.0	12.6	7.5	12	37.8	III	CP-87					100	
	50	10.5	14.1	9.0	16	42	III	CP-88					100	
	70	12.0	16.0	9.0	18	47	III	CP-89					50	
	95	13.5	18.1	9.0	20	52	III	CP-90					50	

MATERIAL - EC GRADE COPPER IS -191

TOLERANCE=± 5%

FINISH : ELECTRO TINNED

WE RESERVE THE RIGHTS AT ANY TIME TO MAKE ANY SPECIFICATION OR DIMENSIONAL CHANGES DEEMED NECESSARY TO ENSURE ADVANCEMENT IN THE DESIGN OR MANUFACTURE OF ANY PRODUCT

LUGS SYSTEM

RECOMMENDED PRACTICE FOR RESISTANCE TO CORROSION.

1. Whilst aluminium withstands weathering without protection during many years service the use of a corrosion inhibiting compound is recommended where conditions are particularly aggressive, such as chemical or salt-laden atmospheres, or where inspection and cleaning are likely to be irregular.

such as inhibitor must :

- a) not affect electrical properties of the compression joint
- b) be non-corrosive to aluminium copper, steel, tin zinc and combinations of these :
- c) not deteriorate on exposure to atmosphere at conductor operating temperatures :
- d) have good sealing properties against moisture and contaminating substances in the atmosphere.
- e) have a high temperature drop point.

2. The following compound is recommended for application over the prepared end of the conductor and inside the ferrule :

"DOWELL'S" CORROSION INHIBITING COMPOUND" GTZ-8785

3. It is a useful procedure to fill the lug with compound. To prevent dirt getting into the corrosion-inhibiting compound and to give added protection to the joint.

We are marketing the above compound.

Packing :

- i) Collapsible Tubes wt. 50 gms.
- ii) 15 Tubes in a Cartoon wt. 800 gms.
- iii) 60 Collapsible Tubes in one Jacket



Demonstration for application of inhibiting compound to clamping & crimping connections.

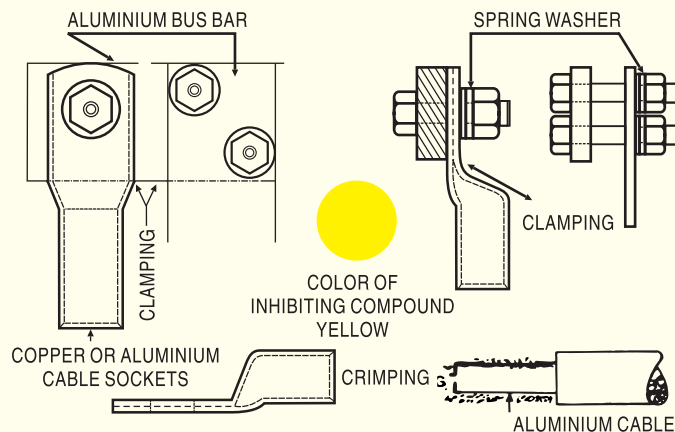

WE RESERVE THE RIGHTS AT ANY TIME TO MAKE ANY SPECIFICATION OR DIMENSIONAL CHANGES DEEMED NECESSARY TO ENSURE ADVANCEMENT IN THE DESIGN OR MANUFACTURE OF ANY PRODUCT

SYT- 2



SYT- 17



SYI-1210/ SYO -1210

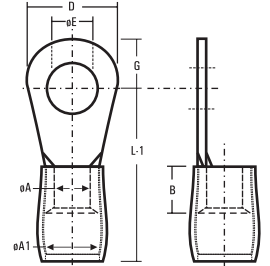
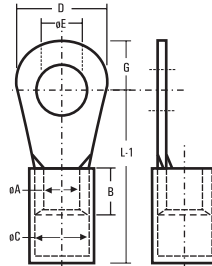
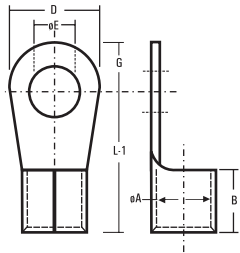

WE RESERVE THE RIGHTS AT ANY TIME TO MAKE ANY SPECIFICATION OR DIMENSIONAL CHANGES DEEMED NECESSARY TO ENSURE ADVANCEMENT IN THE DESIGN OR MANUFACTURE OF ANY PRODUCT

MM ²	E Bolt MMø	øA	D	B	G	L-1	Dowell's CAT. No.	Recomm. Tools Rs	øC	L-1	Dowell's CAT. No.	Recomm. Tools Rs	øA-1	L-1	Dowell's CAT. No.	Recomm. Tools Rs		
1.5	M3	1.6	6.0	5	3.0	11	RS-7001	SYT-2	3.2	16	RSI-7054	SYG-2216	3.6	16	PSD-7437	SYG-2216		
	M3.5						RS-7002										RSI-7055	PSD-7438
	M4						RS-7003										RSI-7056	PSD-7439
	M3.5	1.6	6.8	5	3.4	9.6	RS-7048										RSI-7058	PSD-7441
	M4						RS-7049										RSI-7059	PSD-7442
	M4	1.6	8.0	5	4.0	12.0	RS-7004										RSI-7061	PSD-7444
	M5						RS-7005										RSI-7062	PSD-7445
	M4	1.6	7.0	5	3.5	11.0	RS-7154										RSI-7063	PSD-7446
	M5	1.6	10	5	5.0	13.0	RS-7006										RSI-7065	PSD-7448
	M6						RS-7007										RSI-7066	PSD-7449
M6	1.6	12	5	6.0	12.0	RS-7106	RSI-7067	PSD-7450										
2.5	M3	2.3	6.5	5	3.2	9.5	RS-7107	SYA-427	3.9	14.5	RSI-7068	SYH-1614	4.4	17.7	PSD-7451	SYH-1614		
	M3.5						RS-7008										RSI-7069	PSD-7452
	M3.5	2.3	8.0	5	4.0	12.0	RS-7108										RSI-7070	PSD-7453
	M4						RS-7009										RSI-7071	PSD-7454
	M5						RS-7010										RSI-7072	PSD-7455
	M5	2.3	10	5	5.0	13.0	RS-7109										RSI-7073	PSD-7456
	M6						RS-7011										RSI-7074	PSD-7457
	M5	2.3	12	5	6.0	16.0	RS-7110										RSI-7075	PSD-7458
	M6						RS-7012										RSI-7076	PSD-7459
	M8						RS-7013										RSI-7077	PSD-7460
M8	2.3	16	5	8.0	17.0	RS-7014	RSI-7079	PSD-7462										
M10	2.3	18	5	9.0	20.0	RS-7151	RSI-7081	PSD-7464										
4.6	M4	3.5	8.0	6	4.0	13.0	RS-7155	SYT-17	5.5	21.0	RSI-7083	SYI-1210	6.4	22.0	PSD-7466	S SYI-1210		
	M5						RS-7050										RSI-7084	PSD-7467
	M5	3.5	10	6	5.0	14.0	RS-7016										RSI-7086	PSD-7469
	M6	3.5	12	6	6.0	14.0	RS-7017										RSI-7089	PSD-7472
	M8						RS-7018										RSI-7090	PSD-7473
	M6	3.5	12	6	6.0	16.0	RS-7019										RSI-7092	PSD-7475
	M6	3.5	14	6	7.0	18.5	RS-7115										RSI-7093	PSD-7476
	M8						RS-7020										RSI-7094	PSD-7477
	M8	3.5	16	6	8.0	22.0	RS-7116										RSI-7096	PSD-7479
	M10	3.5	18	6	9.0	21.0	RS-7023										RSI-7099	PSD-7482
M12						RS-7024	RSI-7100	PSD-7483										

MATERIAL - EC GRADE COPPER IS -191

TOLERANCE=± 5%

FINISH : ELECTRO TINNED

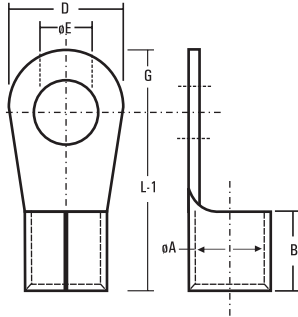

SYT- 2

SYT- 50

SYT- 9

WE RESERVE THE RIGHTS AT ANY TIME TO MAKE ANY SPECIFICATION OR DIMENSIONAL CHANGES DEEMED NECESSARY TO ENSURE ADVANCEMENT IN THE DESIGN OR MANUFACTURE OF ANY PRODUCT

MM ²	E Bolt MMØ	øA	D	B	G	L-1	Dowell's CAT. No.	RECOMMENDED TOOLS & DIES				STD PKG
								SYB 95	SYD 20A	SYE 150A	SYT 185	
10	M5	4.3	10	8	5	17	RS-7025					
10	M5	4.3	10	8	5	15	RS-7026	SYT-2				
10	M6	4.3	12	8	6	17	RS-7120	JBR-1				200
10	M8	4.3	16	8	8	19	RS-7121					
10	M10	4.3	22	8	11	23	RS-7123					
10	M12	4.3	22	8	11	23	RS-7028					
16	M5	5.6	10	10	5	19	RS-7124					
16	M6	5.6	12	10	6	20	RS-7029	SYT-2				
16	M8	5.6	16	10	8	22	RS-7030	JBR-2				200
16	M10	5.6	22	10	11	24	RS-7128					
16	M12	5.6	22	10	11	24	RS-7033					
25	M6	7.5	12	11	6	25	RS-7156					
25	M8	7.5	16	11	8	22	RS-7034					
25	M10	7.5	22	11	11	31	RS-7132	JBR-5				100
25	M12	7.5	22	11	11	31	RS-7037					
35	M6	9.0	16	12	8	23	RS-7133					
35	M8	9.0	16	12	8	23	RS-7038					
35	M10	9.0	22	12	11	31	RS-7135	JBR-6			R-6	100
35	M12	9.0	22	12	11	31	RS-7040					
50	M8	10.5	18	16	9	34	RS-7136					
50	M10	10.5	22	16	11	32	RS-7137					
50	M12	10.5	24	16	12	36	RS-7042	JBR-7			R-7	100
50	M16	10.5	32	16	16	38	RS-7139					
70	M10	12.0	22	18	11	36	RS-7140					
70	M12	12.0	24	18	12	36	RS-7141	JBR-9			R-9	50
70	M16	12.0	28	18	14	40	RS-7142					
95	M10	13.5	24	20	12	38	RS-7144					
95	M12	13.5	24	20	12	38	RS-7044	JBR-10			R-10	50
95	M16	13.5	28	20	14	44	RS-7145					
120	M12	15.0	26	22	13	39	RS-7146					
120	M16	15.0	32	22	16	48	RS-7147	JBR-11	JDR-11	JER-11	R-11	30
120	M20	15.0	40	22	20	52	RS-7148					
150	M12	16.5	34	24	17	49	RS-7149					
150	M16	16.5	34	24	17	49	RS-7045		JDR-13	JER-13		20
150	M20	16.5	40	24	20	54	RS-7046					

MATERIAL - EC GRADE COPPER IS -191

TOLERANCE=± 5%

FINISH : ELECTRO TINNED

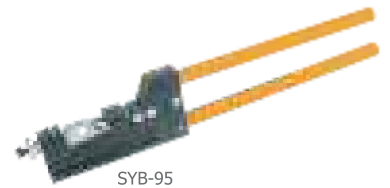

SYB-95

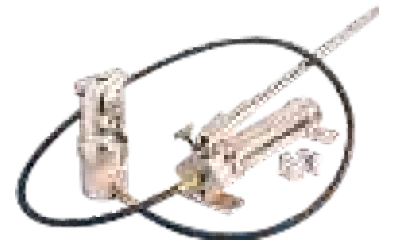

SYD-20

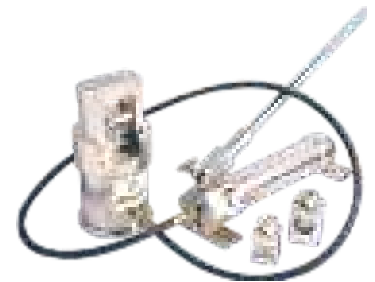

SYE- 150

COPPER TUBULAR TERMINAL ENDS FOR SOLDERLESS CRIMPING TO COPPER CONDUCTORS REF : D.L.W.

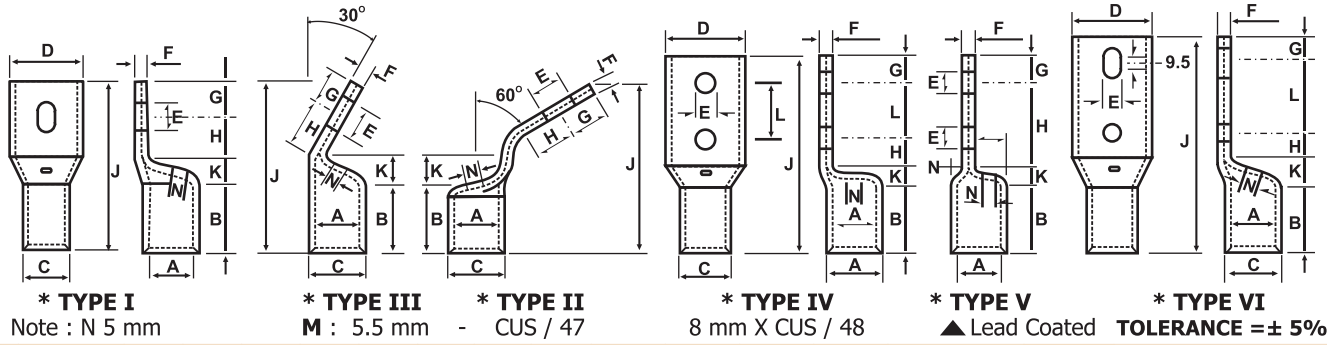

WE RESERVE THE RIGHTS AT ANY TIME TO MAKE ANY SPECIFICATION OR DIMENSIONAL CHANGES DEEMED NECESSARY TO ENSURE ADVANCEMENT IN THE DESIGN OR MANUFACTURE OF ANY PRODUCT

Area mm ²	Cable Size	E	A	C	D	F	B	K	H	G	J	L	Type	Dowell's Cat No.	Retail Packing	Recommendation forming crimping		
																Tool	Die	Die
133	650/0.5	10.3	17.0	22.2	32	5.2	27	8	28	19	82	-	I	CUS / 36	20	D, E	F-150	RH-17-2
133	650/0.5	10.3	17.0	22.2	32	5.2	27	8	28	19	82	-	I	CUS / 37	20	D, E	F-150	RH-17-2
133	650/0.5	10.3	17.0	22.2	32	5.2	27	7	19	14	67	-	I	CUS / 38	20	D, E	F-150	RH-17-2
133	650/0.5	10.3	17.0	22.2	32	5.2	27	7	19	14	67	-	I	CUS / 39	20	D, E	F-150	RH-17-2
133	650/0.5	10.3	17.0	22.2	32	5.2	27	12	19	14	62	-	II	CUS / 40	20	D, E	F-150	RH-17-2
133	650/0.5	10.3	17.0	22.2	32	5.2	27	12	19	14	67	-	III	CUS / 41	20	D, E	F-150	RH-17-2
133	650/0.5	8.7	17.0	22.2	32	5.2	27	8	11	11	79	22.2	V	CUS / 47	20	D, E	F-150	RH-17-2
133	650/0.5	8.7	17.0	22.2	32	5.2	27	11	14	13	109	44.4	VI	CUS / 51 ▲	20	D, E	F-150	RH-17-2
270	1325/0.5	16.6	24.6	31.7	46	7.1	40	11	22	21	94	-	I	CUS / 42	10	D, E	F-270	RH-24-4
270	1325/0.5	13.5	24.6	31.7	46	7.1	40	11	22	21	94	-	I	CUS / 43	10	D, E	F-270	RH-24-4
270	1325/0.5	13.5	24.6	31.7	46	7.1	35	15	22	21	86	-	III	CUS / 44	10	D, E	F-270	RH-24-4
270	1325/0.5	10.3	24.6	31.7	46	7.1	40	8	13	12	97	25.4	V	CUS / 48	10	D, E	F-270	RH-24-4
270	1325/0.5	13.5	24.6	31.7	46	7.1	40	8	13	12	105	31.7	IV	CUS / 49	10	D, E	F-270	RH-24-4
400	1925/0.5	17.4	29.3	37.2	53	7.9	47	10	29	22	108	-	I	CUS / 45	5	E	F-500	RH-29
400	1925/0.5	13.5	29.3	37.2	53	7.9	47	10	29	22	108	-	I	CUS / 46	5	E	F-500	RH-29
400	1925/0.5	14.3	29.3	37.2	53	7.9	51	7	27	13	130	31.7	IV	CUS / 50	5	E	F-500	RH-29

COPPER TUBULAR TERMINAL ENDS FOR SOLDERLESS CRIMPING TO COPPER CONDUCTORS REF : D.L.W.

mm ²	'C-1' Cable Size	mm ²	'C-1' Cable Size	A	C	J	Dowell's Cat No.	Retail Packing	Recommendation		
									Crimping Tool	Forming Die	Crimping Die
1.5	1/1.4	1.5	1/1.4	1.6	3.2	15	EH-453	200	A	-	-
2.5	1/1.8	2.5	1/1.8	2.0	3.7	15	CB-23	200	A	-	-
4	1/2.8	4	1/2.8	3.1	4.8	15	CB-3	200	A	-	-
6	1/3.55	6	1/3.55	3.8	5.5	15	CB-4	200	A	-	-
10	7/1.4	10	7/1.4	4.4	6.2	20	EH-460	200	B,D	-	R-1
16	7/1.7	16	7/1.7	5.3	7.1	20	CB-6	200	B,D	-	R-2
25	7/2.24	25	7/2.24	7.0	9.0	25	CB-7	200	B,D	F-25	R-3
35	7/2.5	35	7/2.5	8.0	10.0	30	CB-8	100	B,D	F-35	R-4
50	19/1.8	50	19/1.8	9.2	11.2	35	CB-9	100	B,D,E	F-50	R-6
70	19/2.24	70	19/2.24	11.5	13.8	40	CB-10	50	B,D,E	F-70	R-7
95	19/2.5	95	19/2.5	12.8	15.6	45	CB-11	50	B,D,E	F-95	R-9
120	37/2.06	120	37/2.06	14.8	17.8	50	CB-12	30	B,D,E	F-120	R-10
150	37/2.24	150	37/2.24	16.0	19.6	55	CB-13	20	D,E	F-150	R-11
185	37/2.5	185	37/2.5	18	22	60	CB-14	20	D,E	F-185	R-12
225	37/2.8	225	37/2.8	20	24	65	CB-20	10	D,E	F-225	R-13
240	61/2.24	240	61/2.24	22	26	65	CB-15	10	D,E	F-240	R-14
300	61/2.5	300	61/2.5	24	28.7	75	CB-16	10	D,E	F-300	R-15
400	61/3.00	400	61/3.00	28	33.2	90	CB-17	5	D,E	F-400	R-17
500	91/2.65	500	91/2.65	30	36	95	CB-18	5	E	F-500	R-18
625	91/3.0	625	91/3.0	35	41.5	105	CB-19	5	E	F-625	R-19
800	91/3.35	800	91/3.35	39	46.3	120	CB-21	5	E	-	R-23
1000	91/3.65	1000	91/3.65	43	53.8	150	CB-22	4	E	-	R-22



MATERIAL - COPPER IS : 191
Finish - Electro Tinned

Crimping tool abbreviation
 A = KOP E=SYE 150A
 B=BRD D=SYD 20A

MATERIAL - EC GRADE COPPER IS -191

TOLERANCE=± 5%

FINISH : ELECTRO TINNED

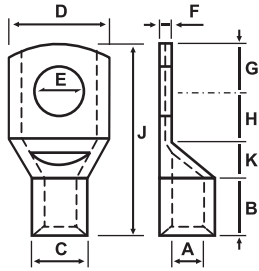

* TYPE I

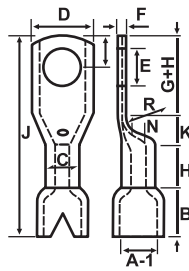

* TYPE III

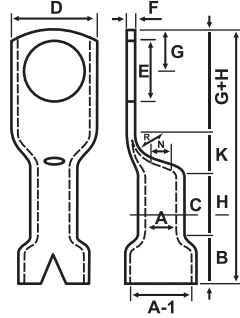

* TYPE VII

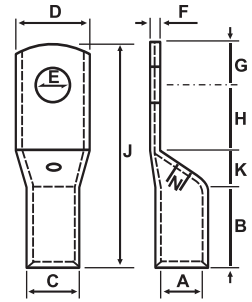

* TYPE IV

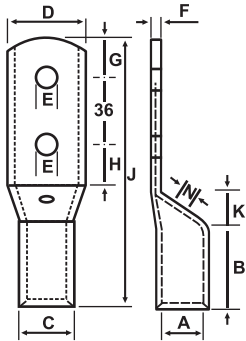

* TYPE V

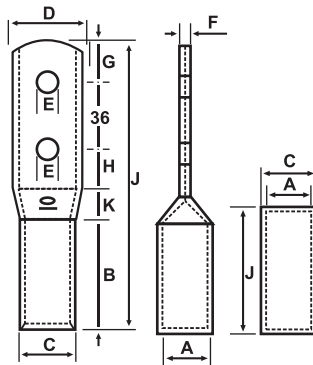

* TYPE VIII

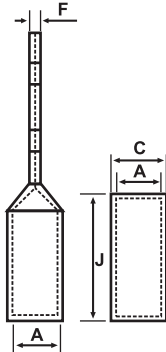

* TYPE VI

TOLERANCE = ± 5%

MATERIAL - COPPER IS : 191
Finish - Electro Tinned

Note : N = 5 mm

Crimping tool abbreviation

A = KOP E=SYE 150A

B=BRD D=SYD 20A

Area mm ²	Cable Size	E	A	C	D	F	B	K	H	G	J	N	Type of Fig.	Dowell's Cat No.	Retail Packing	Recommendation		
																Tool	Forming Die	Crimping Die
3	45/0.3	3.2	2.6	4.6	7.0	1.6	5.5	-	6.5	3.5	15.5	-	I	CUS / 66	200	A	-	2
3	45/0.3	3.2	2.6	4.6	5.0	2.0	5.5	-	6.5	2.5	14.5	-	I	CUS / 67	200	A	-	2
3	45/0.3	4.2	2.6	4.6	7.3	1.5	5.5	-	6.5	4	16	-	I	CUS / 65	200	A	-	2
3	45/0.3	4.2	2.6	4.6	8	1.4	5.5	-	6	4	16	-	I	CUS/ 209	200	A	-	2
3	45/0.3	5.2	2.6	4.6	8	1.4	5.5	-	5	4	16	-	I	CUS/ 210	200	A	-	2
3	45/0.3	6.2	2.6	5.0	10	1.4	8	3	6.5	5	34	1.5	III	CUS/ 211	200	A	-	2
10	144/0.3	6.2	5	7	10	2	10	4	11	7	40	3	VII	CUS/ 228	200	B,D	-	W-1
10	144/0.3	8.2	5	7	12	1.6	10	4	11	7	40	3	VII	CUS/ 68	200	B,D	-	W-1
10	144/0.3	10.2	5	7	14	1.4	10	4	11	7	40	3	VII	CUS/ 69	200	B,D	-	W-1
25	127/0.5	6.2	8	10	15	2	16	5	14	10	45	3	IV	CUS/ 212	100	B,D	F-35	W-13
25	127/0.5	8.2	8	10	15	2	16	5	14	10	45	3	IV	CUS/ 56	100	B,D	F-35	W-13
35	-	8.2	9.6	12	17	2.4	20	5	21	14	60	3	IV	CUS/ 187	100	B,D	F-50	W-6
50	175/0.5	10.5	10.8	14	20	3.2	20	6	20	14	60	3	IV	CUS/ 87	100	B,D	FSD-70	W-7
50	175/0.6	15	10.8	14	20	3.2	20	6	20	14	60	3	IV	CUS/ 230	100	B,D	FSD-70	W-7
70	-	11	12.8	17	24	4.2	25	10	18	12	65	4	IV	CUS/ 229	50	D,E	F-95	W-9
120	427/0.6	14	17	22.2	32	5.2	30	13	27	18	88	4	IV	CUS/ 55	30	D,E	F-150	W-11
120	427/0.6	21	17	22.2	32	5.2	30	13	27	18	88	4	IV	CUS / 70	30	D,E	F-150	W-11
150	525/0.6	16	18	24	34	6	35	12	25	18	90	5	IV	CUS / 54	20	D,E	F-185	W-12
225	760/0.6	16	22	28	40	6	45	12	25	18	100	5	IV	CUS / 213	10	D,E	F-240	W-16
225	760/0.6	11	22	28	40	6	45	12	22	15	130	5	V	CUS / 214	10	D,E	F-240	W-16
225	760/0.6	11	22	28	40	6	45	12	25	18	100	5	IV	CUS / 71	10	D,E	F-240	W-16
270	950/0.6	11	26	32	40	6	55	12	24	15	142	5	VIII	CUS / 215	10	E	F-270	W-17
270	950/0.6	-	26	30	-	-	-	-	-	-	70	-	VI	CUS / 72	10	E	F-270	W-16
475	1680/0.6	11	36.5	46.1	50	9.6	75	15	24	15	165	5	VIII	CUS / 74	5	E	F-475	W-18
475	1680/0.6	22	36.5	46.1	50	9.6	75	15	33	22	145	5	IV	CUS / 73	5	E	F-475	W-18
475	1680/0.6	11	36.5	46.1	50	9.6	75	15	33	22	145	5	IV	CUS / 75	5	E	F-475	W-18

MATERIAL - EC GRADE COPPER IS -191

TOLERANCE=± 5%

FINISH : ELECTRO TINNED

WE RESERVE THE RIGHTS AT ANY TIME TO MAKE ANY SPECIFICATION OR DIMENSIONAL CHANGES DEEMED NECESSARY TO ENSURE ADVANCEMENT IN THE DESIGN OR MANUFACTURE OF ANY PRODUCT

COPPER TUBULAR EXTENDED PALM BLANKS FOR SOLDERLESS CRIMPING TO COPPER / ALUMINIUM CONDUTORS

MATERIAL : E. C GRADE COPPER IS -191 TOLERANCE : ± 5%

MATERIAL : ELECTROLYTTIC ALUMINIUM IS -5082 TOLERANC

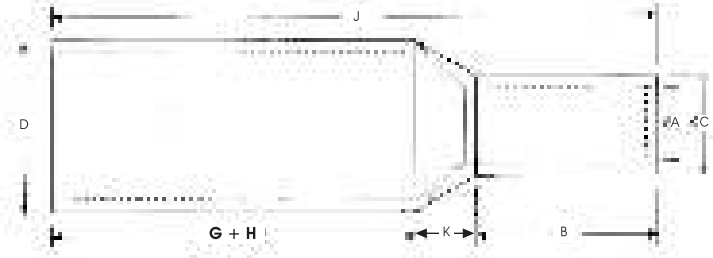

Area mm ²	A	C	D	F	B	K	G+H	J	Marking Dowell's	Dowell's Cat No.	Retail Packing	Recommendation		
												Crimping Tool	Forming Die	Crimping Die
50	9.5	12.4	18	2.9	18	6	42	64	50 S, 35 F	CUS 466	100	B, D, E	F-50	D-5
70	11.2	14.7	21	3.5	16	7	50	75	70 S, 50 F	CUS 467	50	B, D, E	F-70	D-6
95	13.5	17.4	25	3.9	20	9	52	81	95 S, 70 F	CUS 468	50	B, D, E	F-95	D-7
120	15.0	19.4	28	4.4	22	10	56	88	120 S, 95 F	CUS 469	30	D, E	F-120	D-8
150	16.5	21.2	30	4.7	26	11	64	101	150 S, 120 F	CUS 470	20	D, E	F-150	D-9
185	18.5	23.5	34	5.0	32	12	68	112	185 S, 150 F	CUS 471	20	D, E	F-185	D-10
240	21.0	26.5	38	5.5	38	14	80	132	240 S, 185 F	CUS 472	10	D, E	F-240	D-11
300	23.5	30.0	43	6.5	42	15	88	145	300 S, 240 F	CUS 473	10	D, E	F-300	D-12
400	28.5	36.5	53	8.0	44	18	104	166	400 S, 300 F	CUS 474	5	E	F-400	D-13
500	30.0	39.0	56	9.0	48	20	112	180	500 S, 400 F	CUS 475	5	E	F-500	D-14
625	35.0	45.0	65	10.0	56	22	132	210	625 S, 500 F	CUS 476	5	E	F-625	D-15

FOR SOLDERLESS CRIMPING TO COPPER CONDUCTORS REF : I.C.F.

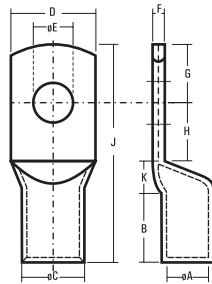

MATERIAL - COPPER IS : 191
Finish - Electro Tinned

Crimping tool abbreviation
A = KOP E=SYE 150A
B=BRD D=SYD 20A

TOLERANCE = ± 5%

Area mm ²	E	A	C	D	F	B	K	H	G	J	Dowell's Cat No.	Retail Packing	Recommendation		
													Crimping Tool	Forming Die	Crimping Die
11-17	5.2	6.0	8.5	11.9	2.5	14	3	10	6	33	CUS 106	200	B, D	FSD-25	W -13
11-17	6.5	6.0	8.5	11.9	2.5	14	3	10	6	33	CUS 145	200	B, D	FSD-25	W -13
11-17	8.2	6.0	8.5	16.0	1.7	14	3	11	9	37	CUS 146	200	B, D	FSD-25	W -13
11-17	10.2	6.0	8.5	16.0	1.7	14	3	11	9	37	CUS 109	200	B, D	FSD-25	W -13
11-23	5.2	7.1	10.2	14.3	3.1	18	4	10	7	39	CUS 107	100	B, D	F-25	W -5
11-23	6.5	7.1	10.2	14.3	3.1	18	4	10	7	39	CUS 147	100	B, D	F-25	W -5
17-23	8.2	7.1	10.2	14.3	3.1	18	4	10	7	39	CUS 148	100	B, D	F-25	W -5
17-23	10.2	7.1	10.2	19.0	2.2	18	4	12	10	44	CUS 108	100	B, D	F-25	W -5
23-29	5.2	8.0	11.7	16.3	3.7	18	4	11	8	41	CUS 110	100	B, D	F-35	W -6
23-29	6.5	8.0	11.7	16.3	3.7	18	4	11	8	41	CUS 149	100	B, D	F-35	W -6
23-29	8.2	8.0	11.7	16.3	3.7	18	4	11	8	41	CUS 150	100	B, D	F-35	W -6
23-29	10.2	8.0	11.7	20.0	2.8	18	4	14	11	47	CUS 151	100	B, D	F-35	W -6
23-29	13.0	8.0	11.7	20.0	2.8	18	4	14	11	47	CUS 111	100	B, D	F-35	W -6
29-45	5.2	9.8	13.7	19.3	3.9	18	5	10	10	43	CUS 116	100	B, D	F-50	W -14
29-45	6.5	9.8	13.7	19.3	3.9	18	5	10	10	43	CUS 152	100	B, D	F-50	W -14
29-45	8.2	9.8	13.7	19.3	3.9	18	5	10	10	43	CUS 153	100	B, D	F-50	W -14
29-45	10.2	9.8	13.7	19.3	3.9	18	5	10	10	43	CUS 154	100	B, D	F-50	W -14
29-45	10.2	9.8	13.7	22.0	3.2	18	5	14	11	48	CUS 113	100	B, D	F-50	W -14

MATERIAL -EC GRADE COPPER IS -191

TOLERANCE=± 5%

FINISH : ELECTRO TINNED

WE RESERVE THE RIGHTS AT ANY TIME TO MAKE ANY SPECIFICATION OR DIMENSIONAL CHANGES DEEMED NECESSARY TO ENSURE ADVANCEMENT IN THE DESIGN OR MANUFACTURE OF ANY PRODUCT

LUGS SYSTEM

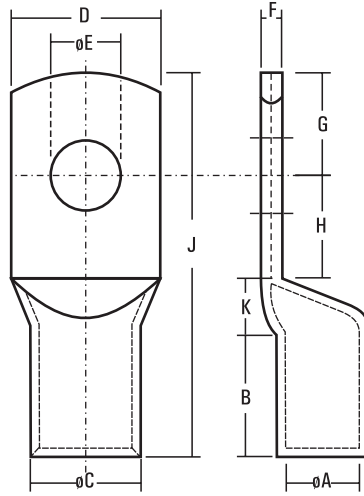

MATERIAL - COPPER IS : 191
Finish - Electro Tinned

Crimping tool abbreviation
 A = KOP E=SYE 150A
 B=BRD D=SYD 20A

TOLERANCE = ± 5%

WE RESERVE THE RIGHTS AT ANY TIME TO MAKE ANY SPECIFICATION OR DIMENSIONAL CHANGES DEEMED NECESSARY TO ENSURE ADVANCEMENT IN THE DESIGN OR MANUFACTURE OF ANY PRODUCT

Area mm ²	E	A	C	D	F	B	K	H	G	J	Dowell's Cat No.	Retail Packing	Recommendation		
													Crimping Tool	Forming Die	Crimping Die
45-57	6.5	11.1	15.8	22.2	4.7	24	6	15	11	56	CUS 112	50	B, D	F-70	W -19
45-57	8.2	11.1	15.8	22.2	4.7	24	6	15	11	56	CUS 155	50	B, D	F-70	W -19
45-57	10.2	11.1	15.8	22.2	4.7	24	6	15	11	56	CUS 156	50	B, D	F-70	W -19
45-57	13.0	11.1	15.8	22.2	4.7	24	6	15	11	56	CUS 157	50	B, D	F-70	W -19
57-75	6.5	12.6	17.8	25.0	5.2	24	6	15	13	58	CUS 114	50	D, E	F-95	W -15
57-75	8.2	12.6	17.8	25.0	5.2	24	6	15	13	58	CUS 158	50	D, E	F-95	W -15
57-75	10.2	12.6	17.8	25.0	5.2	24	6	15	13	58	CUS 159	50	D, E	F-95	W -15
57-75	13.0	12.6	17.8	25.0	5.2	24	6	15	13	58	CUS 160	50	D, E	F-95	W -15
75-90	6.5	13.7	19.1	26.9	5.4	24	6	16	13	59	CUS 137	50	D, E	F-95	W -10
75-90	8.2	13.7	19.1	26.9	5.4	24	6	16	13	59	CUS 161	50	D, E	F-95	W -10
75-90	10.2	13.7	19.1	26.9	5.4	24	6	16	13	59	CUS 162	50	D, E	F-95	W -10
75-90	13.0	13.7	19.1	26.9	5.4	24	6	16	13	59	CUS 163	50	D, E	F-95	W -10
90-110	6.5	15.3	20.9	29.6	5.6	24	6	17	15	62	CUS 115	30	D, E	F-150	W -11
90-110	8.2	15.3	20.9	29.6	5.6	24	6	17	15	62	CUS 164	30	D, E	F-150	W -11
90-110	10.2	15.3	20.9	29.6	5.6	24	6	17	15	62	CUS 165	30	D, E	F-150	W -11
90-110	13.0	15.3	20.9	29.6	5.6	24	6	17	15	62	CUS 166	30	D, E	F-150	W -11
110-146	8.2	17.5	24	34	6.5	29	7	18	17	71	CUS 138	20	D, E	F-185	W -12
110-146	10.2	17.5	24	34	6.5	29	7	18	17	71	CUS 167	20	D, E	F-185	W -12
110-146	13.0	17.5	24	34	6.5	29	7	18	17	71	CUS 168	20	D, E	F-185	W -12
110-146	17.0	17.5	24	34	6.5	29	7	18	17	71	CUS 169	20	D, E	F-185	W -12
146-183	10.2	19.8	26.9	38.2	7.1	29	8	21	18	76	CUS 128	20	D, E	F-225	W -16
146-183	13.0	19.8	26.9	38.2	7.1	29	8	21	18	76	CUS 170	20	D, E	F-225	W -16
146-183	17.0	19.8	26.9	38.2	7.1	29	8	21	18	76	CUS 171	20	D, E	F-225	W -16
183-225	10.2	21.9	29.7	42.2	7.8	29	9	24	21	83	CUS 139	10	D, E	F-240	W -17
183-225	13.0	21.9	29.7	42.2	7.8	29	9	24	21	83	CUS 172	10	D, E	F-240	W -17
183-225	17.0	21.9	29.7	42.2	7.8	29	9	24	21	83	CUS 173	10	D, E	F-240	W -17
183-225	21.0	21.9	29.7	42.2	7.8	29	9	24	21	83	CUS 174	10	D, E	F-240	W -17
225-299	13.0	25.4	34	48.5	8.6	29	10	26	24	89	CUS 140	10	E	F-270	W -20
225-299	17.0	25.4	34	48.5	8.6	29	10	26	24	89	CUS 175	10	E	F-270	W -20
225-299	21.0	25.4	34	48.5	8.6	29	10	26	24	89	CUS 176	10	E	F-270	W -20
299-366	13.0	28.0	37.6	53.6	9.6	38	11	29	26	105	CUS 141	5	E	F-400	W -18
299-366	17.0	28.0	37.6	53.6	9.6	38	11	29	26	105	CUS 177	5	E	F-400	W -18
299-366	21.0	28.0	37.6	53.6	9.6	38	11	29	26	105	CUS 178	5	E	F-400	W -18
366-437	13.0	30.5	41.7	59.1	11.2	38	12	32	29	111	CUS 142	5	E	F-500	W -21
366-437	17.0	30.5	41.7	59.1	11.2	38	12	32	29	111	CUS 179	5	E	F-500	W -21
366-437	21.0	30.5	41.7	59.1	11.2	38	12	32	29	111	CUS 180	5	E	F-500	W -21

MATERIAL - EC GRADE COPPER IS -191

TOLERANCE=± 5%

FINISH : ELECTRO TINNED

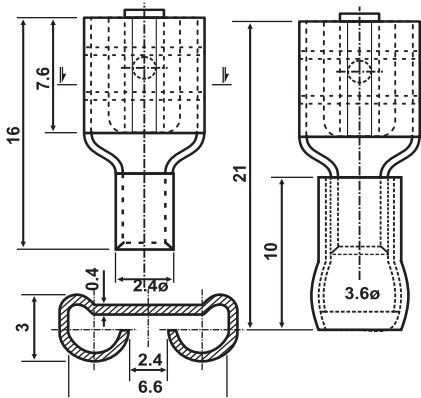
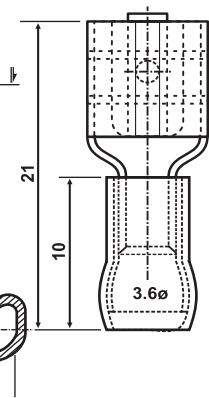
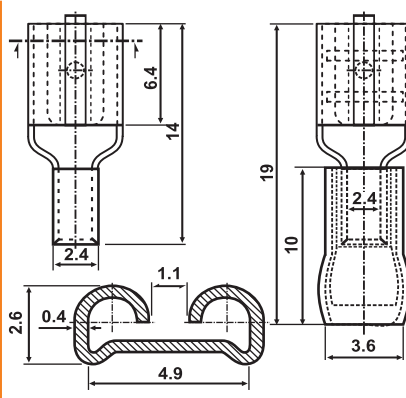
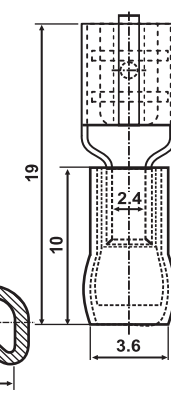
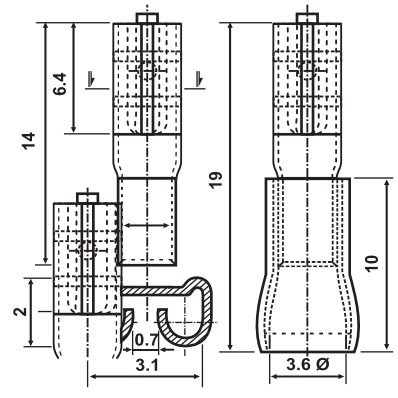
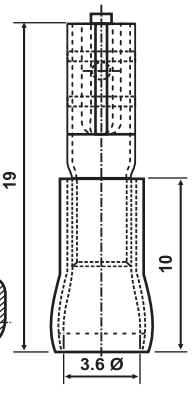
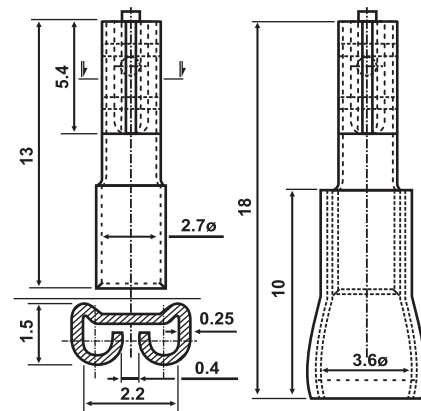
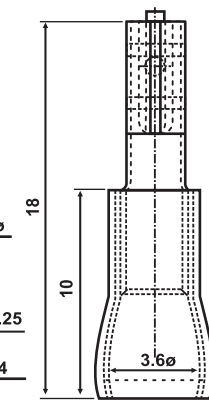
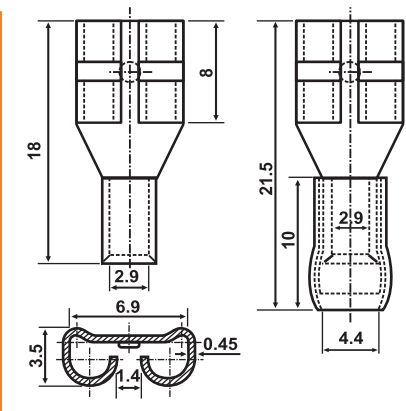
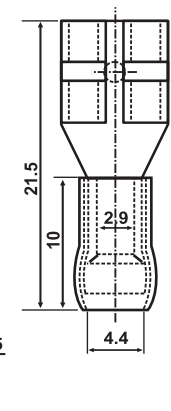
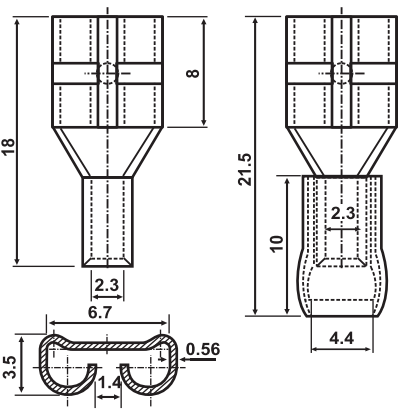
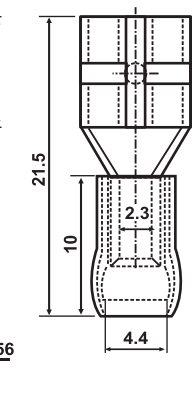
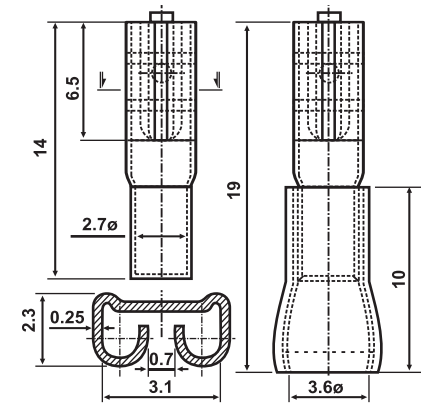
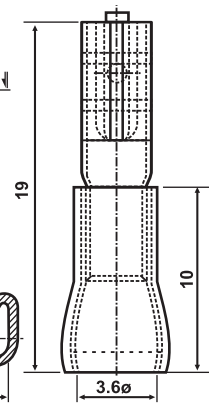
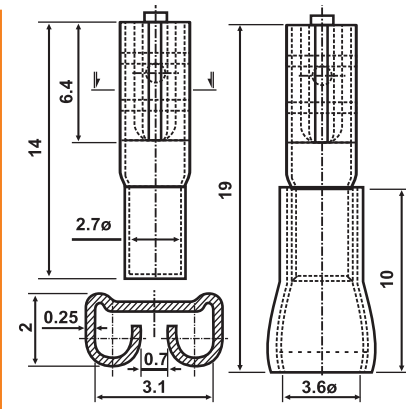
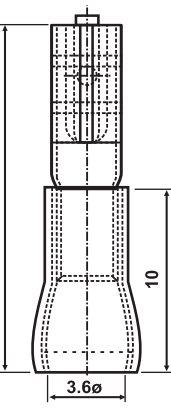
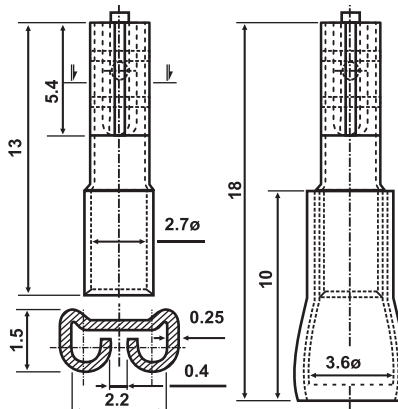
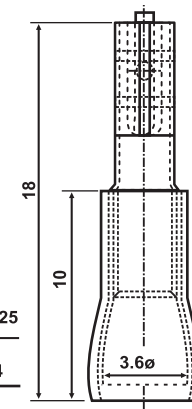
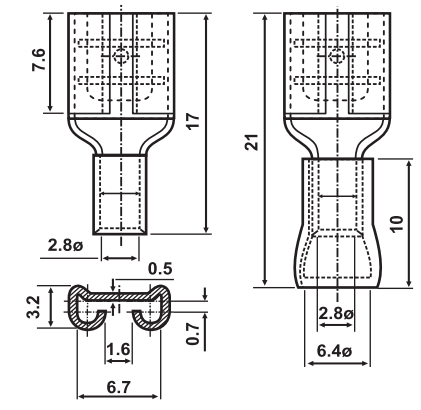
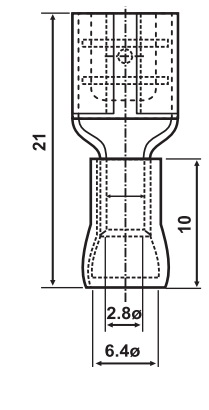
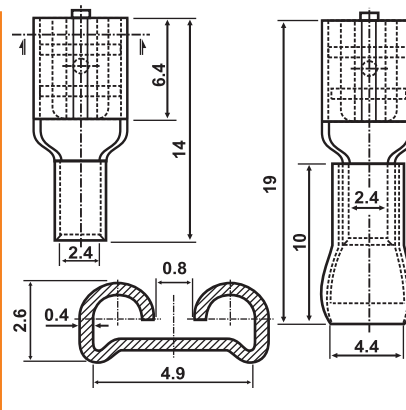
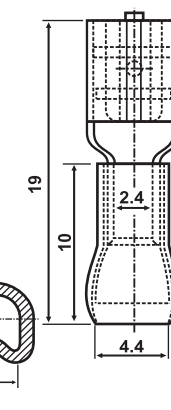
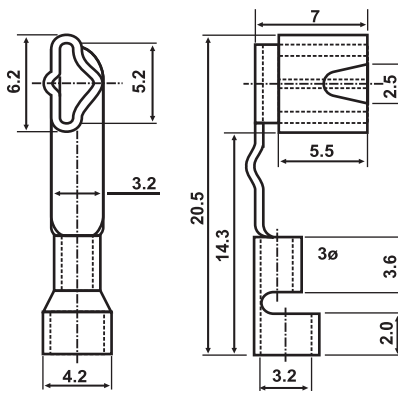

Cat. No. 8351

Cat. No. 8352

Cat. No. 8358

Cat. No. 8359

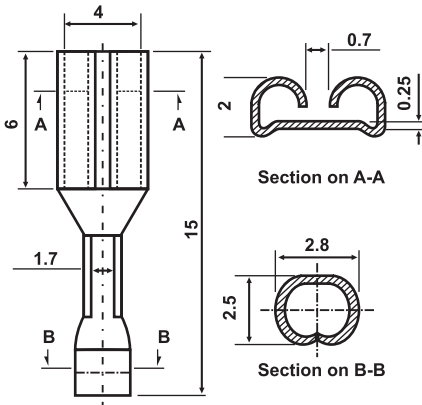
Cat. No. 8324

Cat. No. 8325

Cat. No. 8354

Cat. No. 8355

Cat. No. 8366

Cat. No. 8474

Cat. No. 8365

Cat. No. 8475

Cat. No. 8245

Cat. No. 8331

Cat. No. 8336

Cat. No. 8362

Cat. No. 8356

Cat. No. 8357

Cat. No. 8347

Cat. No. 8476

Cat. No. 8197

Cat. No. 8353

Cat. No. 8477

MATERIAL -BRASS

TOLERANCE=± 5%

WE RESERVE THE RIGHTS AT ANY TIME TO MAKE ANY SPECIFICATION OR DIMENSIONAL CHANGES DEEMED NECESSARY TO ENSURE ADVANCEMENT IN THE DESIGN OR MANUFACTURE OF ANY PRODUCT

LUGS SYSTEM



Cat. No. 8368

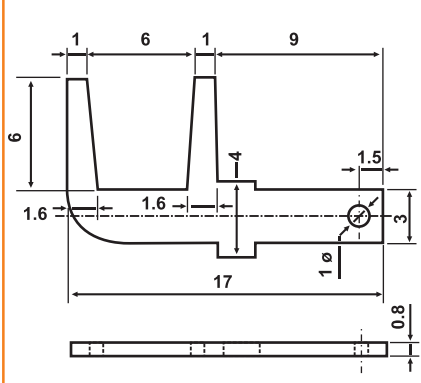

Cat. No. 8370

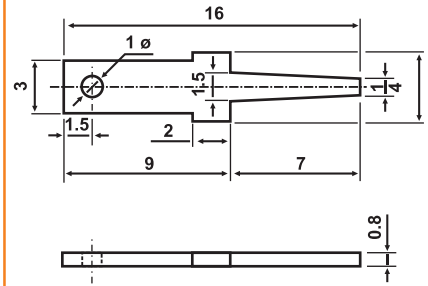

Cat. No. 8369

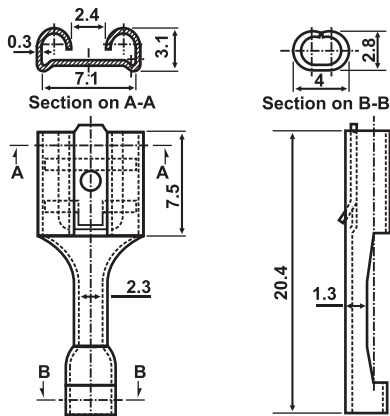

Cat. No. 8364

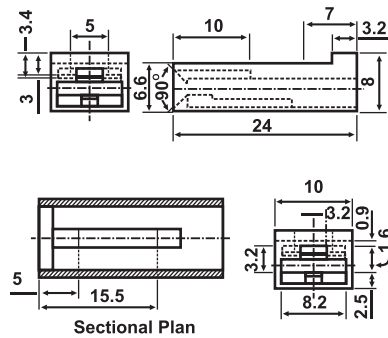

Cat. No. 8367

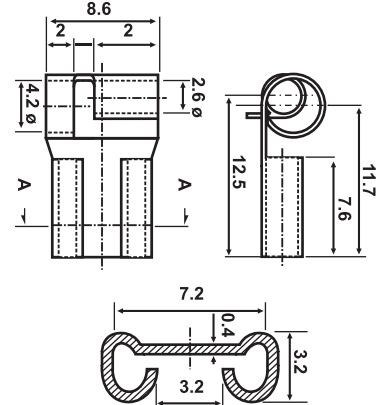

Cat. No. 8178

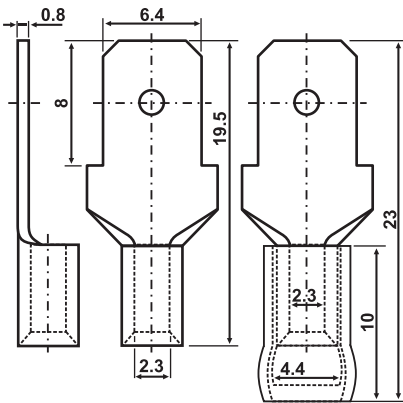

Cat. No. 8363 / Cat No. 8473

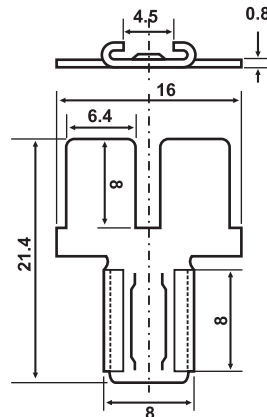

Cat. No. 8346

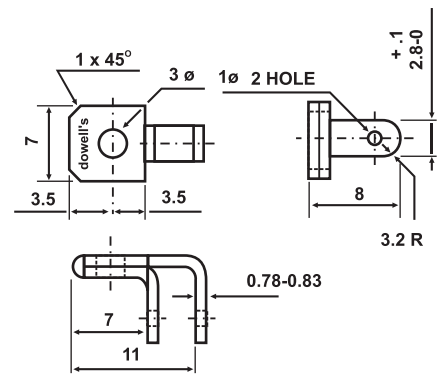

Cat. No. 8214

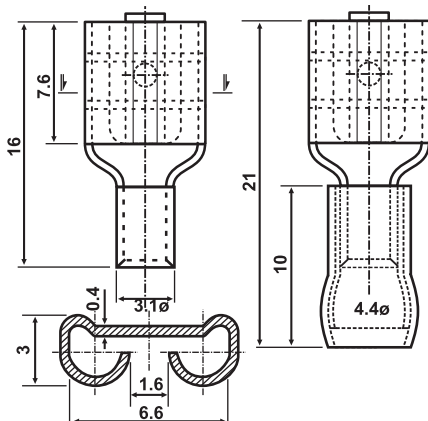

Cat. No. 8349 / Cat No. 8350

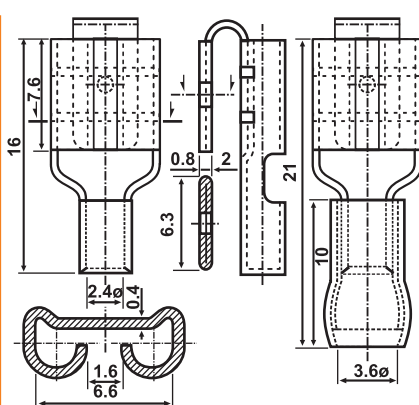

Cat. No. 8360 / Cat No. 8361

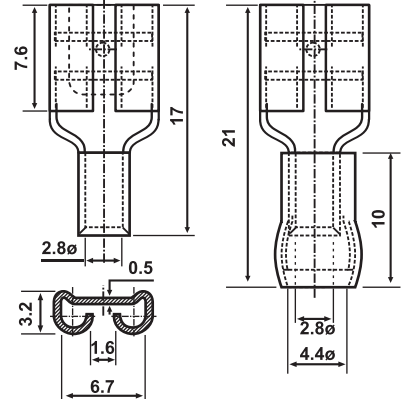

Cat. No. 8347 / Cat No. 8348

WE RESERVE THE RIGHTS AT ANY TIME TO MAKE ANY SPECIFICATION OR DIMENSIONAL CHANGES DEEMED NECESSARY TO ENSURE ADVANCEMENT IN THE DESIGN OR MANUFACTURE OF ANY PRODUCT

MATERIAL -BRASS

TOLERANCE=± 5%

SYT-17

Capacity : 1.5mm² to 4-6mm²
Special Features : Non-Insulated terminations with inter locking arrangement and releasing system.
SYT-427

Capacity : 1.5mm² to 10mm²
Special Features : Non-insulated terminations with inter locking, arrangement and releasing system.
SYT-2

Capacity : 0.5mm² to 16mm²
Special Features : Non-Insulated terminations with inter locking arrangement and releasing system.
SYT-185
(12 set of ring dies)

Capacity : 10mm² to 185mm²
Special Features : Changeable ring types of dies from R1 to R13.

SYG - 2622 - 0.75 mm²
SYG - 2216 - 1.5 mm²
SYG - 1614 - 2.5 mm²
(Insulated/ Pre-Insulated)
SYT-400

Capacity : 25mm² to 400mm²
Special Features : Hand operated crimping system with hexagonal dies.
SYI-1210/ SYO-1210
(Insulated/ Pre- Insulated)

Capacity : 4mm² - 6mm²
SYT-52M
(For end sealing ferrules)

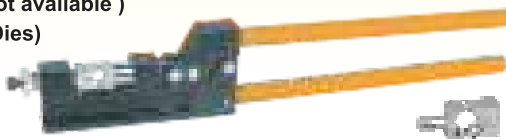
Capacity : 0.5mm² to 6mm²
Special Features : Insulated terminations with inter locking arrangement and releasing system.
SYB-95 (R-1 to R-10)
(R-8 Die is not available)
(9 Set Ring Dies)

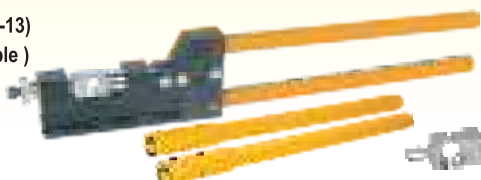
Capacity : 10mm² to 95mm²
SYT-1546
(Insulated)

Capacity : 1.5mm² to 4-6mm²
Special Features : Insulated terminations with inter locking arrangement and releasing system.
SYB-9502 (R-1 to R-13)
(R-8 Die is not available)
(12 Set Ring Dies)

Capacity : 10mm² to 185mm²
SYT-9
(Dieless)





Capacity : 6mm² to 50mm²
Special Features : Manual dieless (HEX-profile) rotating range for aluminium terminations.
SYB-9502 H
(RH-1 to RH-13 Hex Dies)

Capacity : 10mm² to 185mm²
SYT-50
(Dieless)

Capacity : 16mm² to 50mm²
Special Features : Hand operated crimping tool

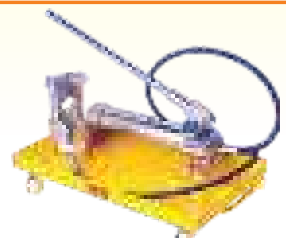
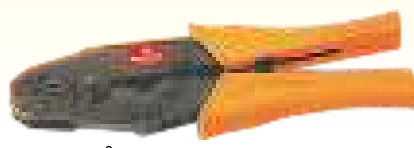
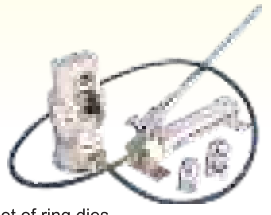
* In the View of Continuous Developments We Reserve the right to modify the Design & Dimensions without Notice

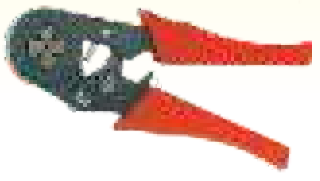
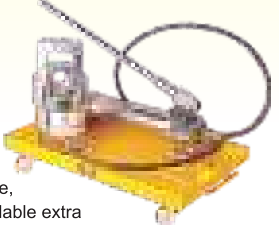
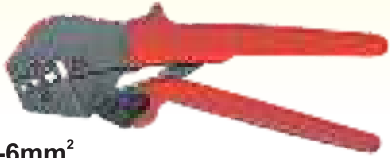
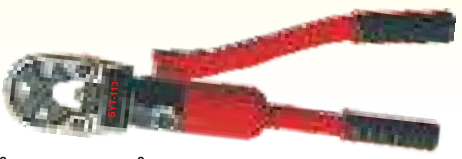
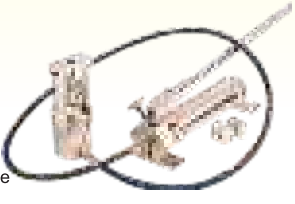
* We Design Specific Crimping tools and Dies as per Job Specifications.

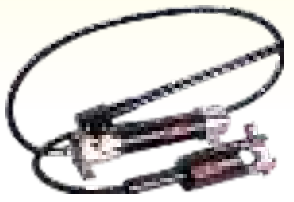
<p>SYT-53 M (End sealing terminal)</p>  <p>Capacity : 10mm² to 35mm² Special Features : For End Sealing Ferrules Insulated & Non- Insulated</p>	<p>SYD-20C</p>  <p>Capacity : 10mm² to 300mm² Special Features : Hand operated hydraulic tool with trolley arrangement</p>
<p>SYT-11 (Snap on terminal)</p>  <p>Capacity : 1.5mm² to 4.6mm² Special Features : Self Locking & releasing Mechanism, Suitable for Non-Insulated Snap on Terminals.</p>	<p>SYE-150A (R11 to R18)</p>  <p>Capacity : 10mm² to 1000mm² Special Features : Hand operated hydraulic crimping system with 8 set of ring dies</p>
<p>SYT- 6-6 (End sealing ferrules)</p>  <p>Capacity : 0.25mm² to 6mm² Special Features : Self adjusting Crimping tools For end sealing ferrules</p>	<p>SYE-150B (10 set of Hex Dies)</p>  <p>Capacity : 10mm² to 1000mm² Special Features : Hand operated hydraulic tools 120mm² to 1000mm² cable with 10 to 95 dies shall be charges extra.</p>
<p>SYT- 16-4 (End sealing ferrules)</p>  <p>Capacity : 6mm² to 16mm² Special Features : Self adjusting crimping tools For end sealing ferrules</p>	<p>SYE-150C (R 11 to R-16)</p>  <p>Capacity : 10mm² to 1000mm² Special Features : Hand operated hydraulic changeable ring dies forming dies, W-type, D- type, P- type, T- type, H/RH- type dies also available extra</p>
<p>SYT-1547 (Insulated terminal)</p>  <p>Capacity : 1.5mm² to 4-6mm² Special Features : Crimping machine for pre-insulated type terminals</p>	<p>SYT- 102 R (Foot Operated) (11 set of Hex Dies)</p>  <p>Capacity : 50mm² to 630mm² Special Features : Easy carry light weight crimping modified head with foot operated hydraulic pump. flip Head (Hexagonal Dies)</p>
<p>SYT-113</p>  <p>Capacity : 25mm² to 240mm² Special Features : Flip type head</p>	<p>SYD-20 A (R 11 to R-16)</p>  <p>Capacity : 10mm² to 300mm² Special Features : Hand operated hydraulic changeable ring dies forming dies, W-type, D- type, P- type, T- type, H/RH- type dies also available extra</p>
<p>SYT-7</p>  <p>Capacity : 25mm² to 400mm² Special Features : Gearpowered Changeable Regular hex dies with interlocking releasing system</p>	<p>SYD-20 B (8 Set of Hex Dies)</p>  <p>Capacity : 50mm² to 400mm² Special Features : Hand operated hydraulic changeable Changeable hexagonal dies</p>

* In the View of Continuous Developments We Reserve the right to modify the Design & Dimensions without Notice
* We Design Specific Crimping tools and Dies as per Job Specifications.

SYM-300



Capacity : 16mm² to 300mm²

Special Features : Mechanical crimping tool for tubular cable lug & connector crimping hexagonal crimping with telescopical handle

SYHX-150 (Dieless)

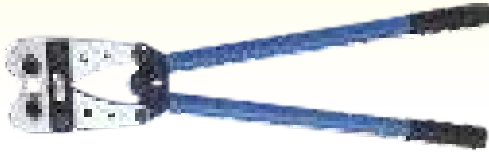

Capacity : 10mm² to 150mm²
Hand Crimping Tool

SYB-120 (Dieless)



Capacity : 10mm² to 120mm²

Special Features : For non - Insulated Terminal from 10-120 mm² with Moveable and Revolving Die Non-Insulated Ring Terminal Range - 10-120 Copper Tube Terminal Range 10-120 mm²

SYHX-120

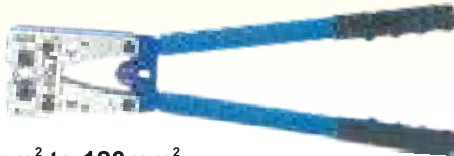

Capacity : 10mm² to 120mm²

Special Features : Rotating Dies

SYT-107 / SYT - 108 (with hexagonal dies) (10 to 120mm²) (16 to 300mm²)



Special Features : New versatile head, light weight faster perfect crimping

SYT-109 (with hexagonal dies)



Capacity : 50mm² to 400mm²

Special Features : Hand operated hydraulic crimping tool

SYT-106 (with hexagonal dies)



Capacity : 16mm² to 300mm²

Special Features : Hand operated hydraulic crimping tool

SYT-104

(with hexagonal dies)



Capacity : 50mm² to 400mm²

Special Features : Flip type head

SYO- 510H

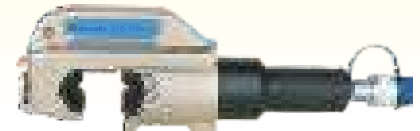

Capacity : 50mm² to 400mm²

Special Features : Hydraulic crimping head, ram stroke 38mm with hexagonal die set

SPO-400H



Capacity : 50mm² to 400mm²

Special Features : Hydraulic Crimping Head Flip type head

SYT-110

(Dieless)

16mm²-400mm²



Flip Type / Portable / Hand Operated Hydraulic Crimping Tools
Slim Design, Light Weight, Faster Lighter Tools

CTE-25 AS

Capacity :
Max pressure 700 kg. / cm²

Special Features : Electrically Operated Pump
Voltage 220 & 50/ Hz storage oil 4 ltr. wt. 15.2 kg.

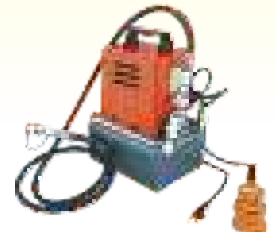

SYT - 120 - (Cutter) SYT - 240 - (Cutter) SYT - 500 - (Cutter)



Capacity : 120mm² to 240mm² to 500mm²

Special Features : Mechanical cable cutter for cutting copper & aluminium cable

SYXL-240

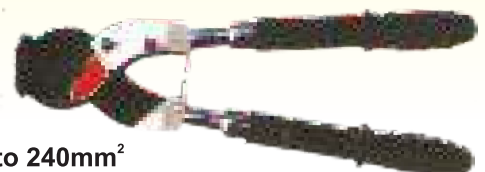

Capacity : Upto 240mm²

Special Features : Mechanical cable cutter for XLPE Cables

Suitable For Cable Overall Diameter		Double Compression Brass Cable Glands			
		Weather proof (DBW)		Flame Proof (DBF)	
Description OD (mm)	Nipple ET Thread	Code	Box Pkg.	Code	Box Pkg.
6.0 - 12.0	3/4"	DBW01SS	35	DBF01SS	35
12.0 - 16.5	3/4"	DBW01S	35	DBF01S	35
16.5 - 18.5	3/4"	DBW01	25	DBF01	25
16.5 - 18.5	1"	DBW01A	20	DBF01A	20
18.5 - 20.0	1"	DBW02	18	DBF02	18
18.5 - 20.0	3/4"	DBW02A	18	DBF02A	18
20.0 - 23.0	1"	DBW03	18	DBF03	18
23.0 - 26.0	1"	DBW04	12	DBF04	12
23.0 - 26.0	1 1/4"	DBW04A	12	DBF04A	12
26.0 - 30.0	1 1/4"	DBW05	10	DBF05	10
26.0 - 30.0	1 1/2"	DBW05A	10	DBF05A	10
30.0 - 33.0	1 1/2"	DBW06	8	DBF06	8
30.0 - 33.0	1 1/4"	DBW06A	8	DBF06A	8
33.0 - 37.0	1 1/2"	DBW07	6	DBF07	6
37.0 - 41.0	2"	DBW08	5	DBF08	5
41.0 - 46.0	2"	DBW09	5	DBF09	5
46.0 - 52.0	2"	DBW010	3	DBF010	3
46.0 - 52.0	2 1/2"	DBW010A	3	DBF010A	3
52.0 - 61.0	2 1/2"	DBW011	2	DBF011	2
61.0 - 66.0	3"	DBW012	2	DBF012	2
66.0 - 72.0	3"	DBW013A	1	DBF013A	1
72.0 - 78.0	3 1/4"	DBW013	1	DBF013	1
78.0 - 84.0	3 1/2"	DBW014	1	DBF014	1
84.0 - 94.0	4"	DBW015	1	DBF015	1
94.0 - 104.0	4 1/2"	DBW016	1	DBF016	1



DOWELL'S SINGLE COMPRESSION TYPE BRASS CABLE GLAND DULY NICKLE PLATED

HEAVY DUTY SERIES			SIBG SERIES	
Gland Size		Box Packing	Gland Size	Box Packing
Inch	mm.			
1/2"	12	128	1616	96
5/8"	16	135	1619	96
3/4"	19	105	2119	54
7/8"	22	84	2125	54
1"	25	54	2925	24
1 1/8"	28	30	2932	24
1 1/4"	32	24	2938	12
1 3/8"	35	24	3638	12
1 1/2"	38	16	4251	8
1 3/4"	45	12	5451	6
2"	50	10	5463	5
2 1/4"	57	6	6063	4
2 1/2"	63	4	6675	4
2 3/4"	70	4	7882	3
3"	75	4		
3 1/4"	82	3		
3 1/2"	88	3		
4"	100	1		
4 1/2"	110	1		

