



CONNECT AND PROTECT

Surge Protection Solutions

Product Selection Guide

nvent

ERICO

NOTE: Product application information given in this document is of a general nature. Installers of the product are cautioned to ensure product is always installed in accordance with any applicable National Standards, Codes, and Practices.

The Need for Coordinated Protection



CRITICAL FACTORS

Critical factors need to be considered when determining the need for facility protection. Many factors can be determined by answering the following questions:

- What is the risk to personnel?
- What is the risk of equipment damage?
- What are the consequences of equipment failure?
- Is the equipment associated with an essential service?
- How will equipment failure affect overall facility operation and revenue generation?
- What are the legal implications of providing inadequate protection?

The statistical nature of lightning and the broad spectrum of energy delivered by a lightning flash, the problems created by various power generation and distribution systems, and the continued trend to more sensitive and specialized electronics, requires careful selection of available technologies if adequate protection is to be provided.

WHAT ARE THE COSTS OF INADEQUATE PROTECTION?

The costs that can result from inadequate protection are many and varied. The type of equipment within a facility will have a direct impact on the damage that can occur. Robust equipment, such as lighting and air-conditioning systems, are often able to withstand impulses as high as 1500 volts and are not as sensitive to the rapid rate-of-rise exhibited by the pre-clamped surge waveform as are electronics.

These systems are often not critical to the continuing operation of the site and therefore usually do not require the premium level of protection that is essential for more sensitive equipment.

However, significant damage can occur, even to the more robust systems, as a result of lightning induced surges resulting within a radius of several kilometers, or from switching induced surges. Costs can range from degradation of electrical or electronic systems to data loss, equipment destruction or injury to personnel. Some of these costs can appear relatively minor but the loss of an essential service or revenues associated with a facility or plant shut down can be enormous.

SOURCES OF TRANSIENTS AND SURGES

Although lightning is the most spectacular form of externally generated surges, it is only one source of over-voltage. Other sources include the switching of power circuits, the operation of electrical equipment by neighboring industries, the operation of power factor correction devices, and the switching and clearing of faults on transmission lines. It is important to note that lightning does not need to directly strike a power line for such damage to occur; a strike several hundred meters away can induce large damaging transients, even to underground cables.

It is estimated that 70 to 85% of all transients are generated internally within one's own facility by the switching of electrical loads such as lights, heating systems, motors and the operation of office equipment.

Modern industry is highly reliant on electronic equipment and automation to increase productivity and safety. The economic benefits of such devices are well accepted. Computers are commonplace and microprocessor-based controllers are used in most manufacturing facilities. Microprocessors can also be found embedded in many industrial machines, security & fire alarms, time clocks and inventory tracking tools. Given the wide range of transient sources and the potential cost of disruption, the

initial installed cost of surge protection can readily be justified for any facility.

As a guide, the cost of protection should be approximately 10% of the cost of the facility's economic risk.



Damage to vital equipment caused by destructive surges and transients.

The Need for Coordinated Protection

Reliable protection of structures, industrial and commercial operations and personnel, demands a systematic and comprehensive approach to minimize the threats caused by transient over-voltages. Grounding, bonding, lightning protection and surge protection all need to be considered for comprehensive facility electrical protection. Each of these are interdependent disciplines that need a holistic design approach to ensure the facility is not left with a vulnerable “blind spot”. The investment in surge protection can be wasted if “blind spots” exist. For example, installing a surge protection device on the power supply to a programmable logic controller is of little value if the I/O lines are not also protected. In addition, an air terminal on the facility may capture the lightning energy but without a dependable ground system, this energy

cannot be safely dissipated. Equally, even the most expensive Surge Protection Devices (SPDs) are poor performers if a low impedance equipotential ground is not provided. These interdependent disciplines are best applied when looking at a total facility rather than at an individual piece of equipment or portion of the facility.

It is for these reasons that nVent ERICO developed the Six Point Plan of Protection. The plan prompts the consideration of a coordinated approach to lightning protection, surge and transient protection and grounding, an approach that embraces all aspects of potential damage, from the more obvious direct strike to the more subtle mechanisms of differential earth potential rises and voltage induction at service entry points.

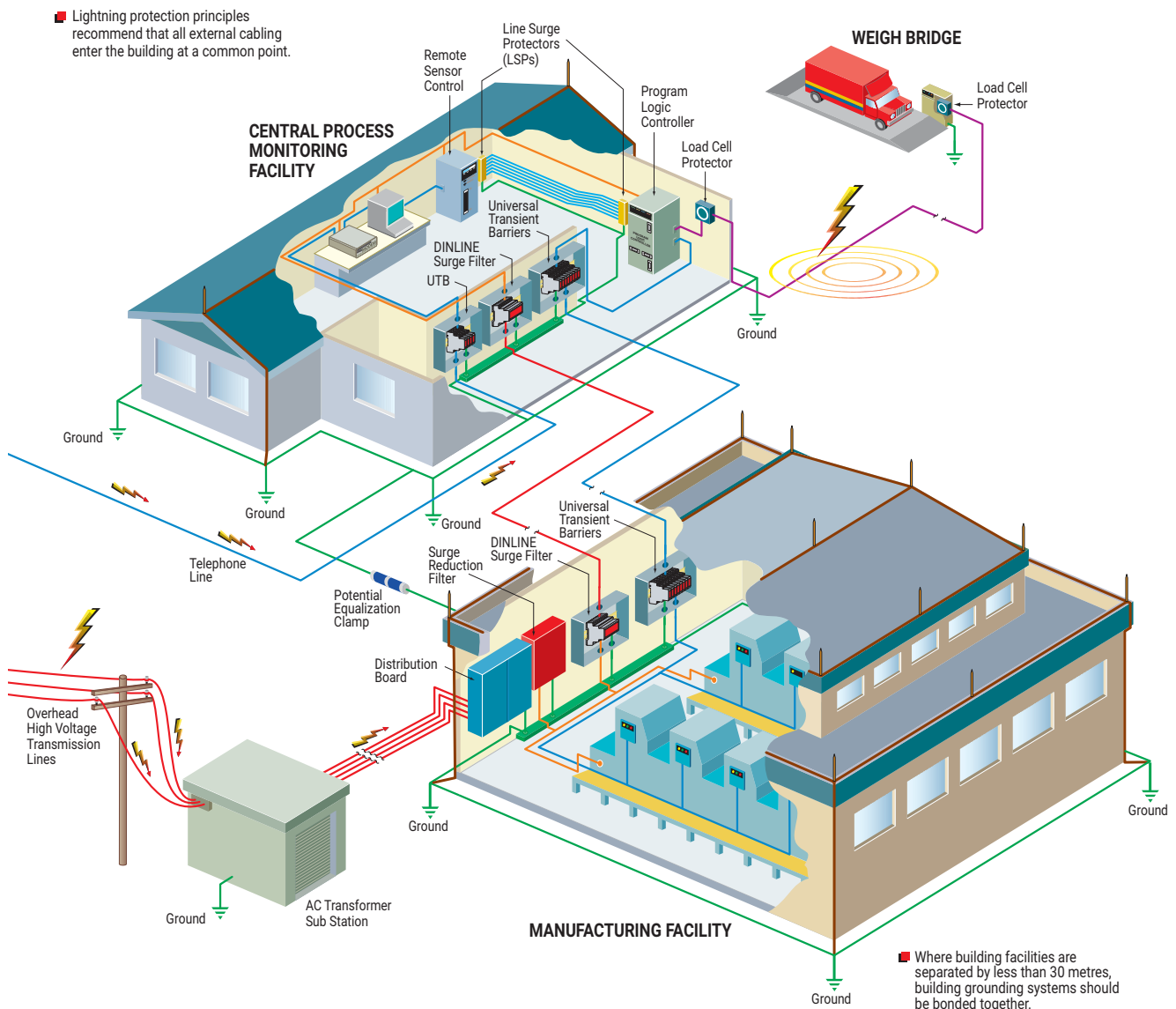

The Six Point Plan applied to a manufacturing facility. Surge and transient protection principles applied to a total facility rather than individual pieces of equipment.

Six Point Plan of Protection

By following the Six Point Plan of Protection, nVent ERICO customers are able to implement the most effective solutions to individual lightning, grounding and surge problems while retaining an integrated protection philosophy.

Point 5 of the Six Point Plan advocates protection of AC power services, advocating a coordinated approach to surge protection, where the first stage of defense is the installation of primary protection devices at the mains supply service entrance, followed by secondary protection at distribution branch panels and where necessary, at point-of-use applications.

Point 6 recognizes the need to provide effective surge protection on cables supplying telecommunications, signal and data management equipment.

The Six Point Plan of Protection from nVent ERICO

- 1 Capture the lightning strike.**
Capture the lightning strike to a known and preferred attachment point using a purpose-designed air terminal system.
- 2 Convey this energy to ground.**
Conduct the energy to the ground via a purpose-designed downconductor.
- 3 Dissipate energy into the grounding system.**
Dissipate energy into a low impedance grounding system.
- 4 Bond all ground points together.**
Bond all ground points to eliminate ground loops and create an equipotential plane.
- 5 Protect incoming AC power feeders.**
Protect equipment from surges and transients on incoming power lines to prevent equipment damage and costly operational downtime.
- 6 Protect low voltage data/telecommunications circuits.**
Protect equipment from surges and transients on incoming telecommunications and signal lines to prevent equipment damage and costly operational downtime.

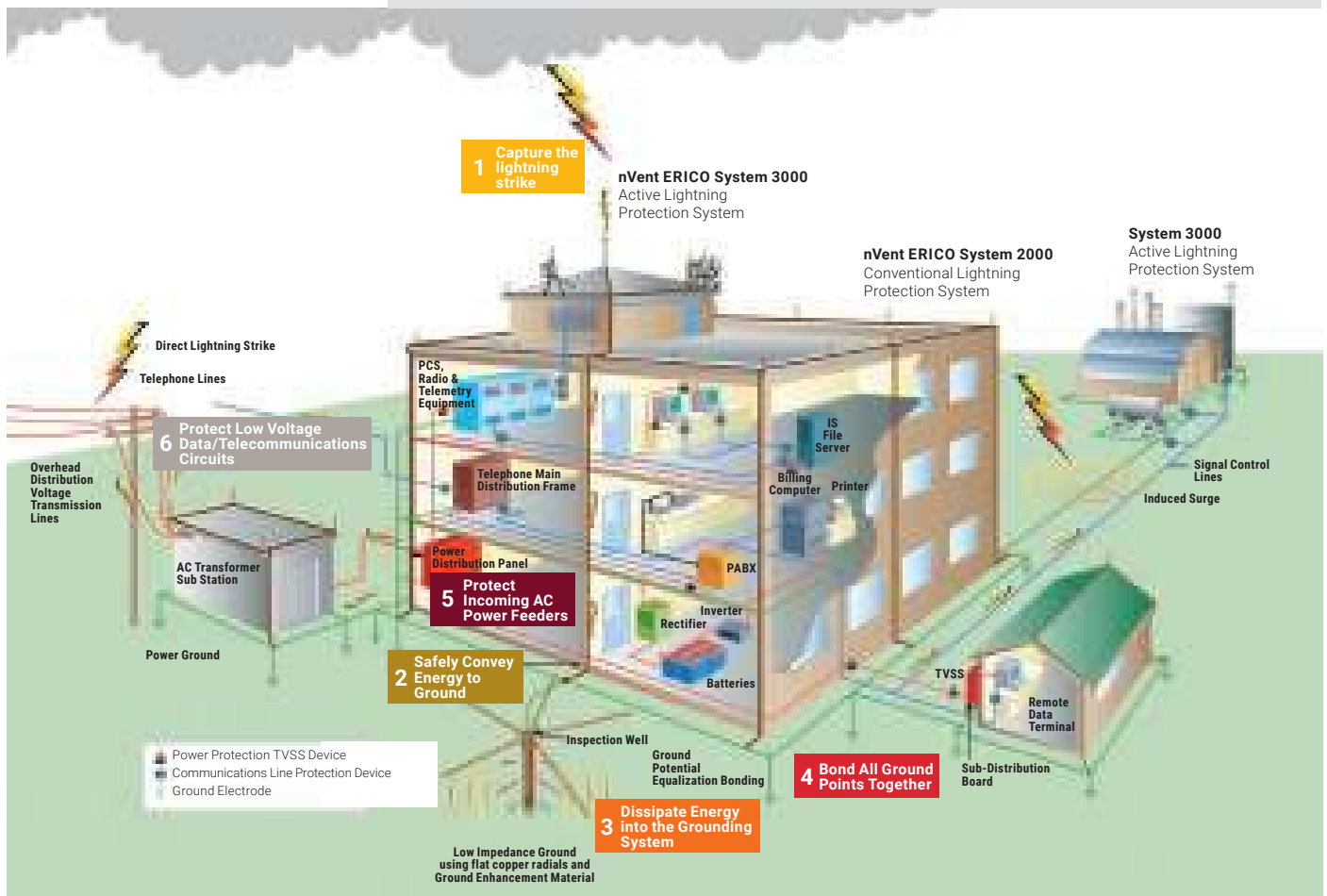

nVent ERICO Expertise

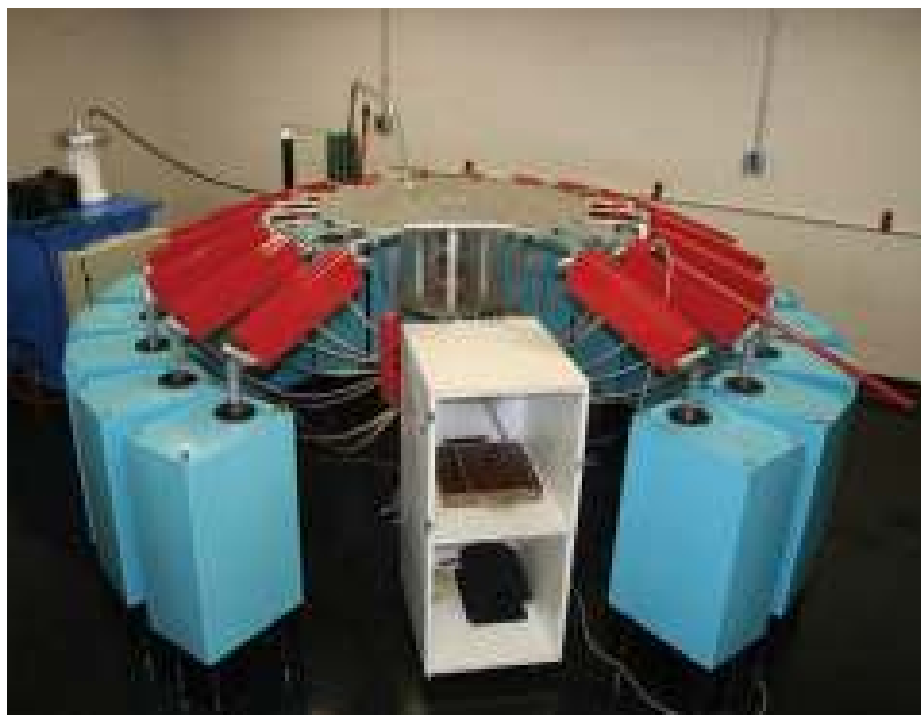

The nVent ERICO advantage is our approach to the complete Facility Electrical Protection Solution. Well designed and high quality Surge Protection is critical to a facility equipment's reliable operation, however it is only part of the solution.

nVent ERICO therefore offers the complete range and expertise in grounding, bonding, surge and lightning protection, providing the complete solution worldwide and across applications including Commercial, Industrial, Telecom, Utility and Railway. Our service and expertise encompasses more than just the product.

PRODUCT TESTING

To effectively meet market requirements and ensure our products are designed and tested to the highest of performance standards, nVent ERICO has invested in state of the art testing equipment that is able to:

- Support application testing for clients – to ensure your equipment is adequately protected.
- Participate in the UL Client Test Data Program.
- Support competitive product testing.
- Test and evaluate to a range of mechanical, electrical and environmental requirements.

HISTORY

nVent ERICO continues to be a pioneer in the low voltage Surge Protection industry, having been involved in grounding and bonding applications for over 100 years, and as a manufacturer of SPDs for over thirty years.

Our involvement in the industry predates the creation of the initial IEC and UL low voltage surge protection standards. We've been on the journey since the early days of Low Voltage AC surge protection, with the issuing of the IEEE587 standard in 1980, and we have been active on all major worldwide SPD standards committees and industry bodies (including IEEE, IEC, and UL) since.



SEMINARS AND SITE AUDITS

Each year nVent ERICO conducts hundreds of seminars in numerous countries around the world, educating specifiers, engineers, and installers on Facility Electrical Protection, of which surge protection plays a key role.

Certified Surge Protection Devices



nVent ERICO surge protective devices (SPDs) provide the option for traditional construction or TD technology. For example, the DT product line features traditional construction, while the EDT product line features with TD technology. These product lines have been designed and independently tested and certified to the latest editions of both IEC61643-11 and UL1449 Ed4.

This provides the user of the product peace of mind that the products will perform safely in application, and also perform to the claimed ratings provided. Both these standards have stringent tests that are not easy to pass, but essential to ensure the product is designed well for safe behavior, and for effective protection performance to the product ratings.

Compliance to these standards are required by code in many countries, however still many countries around the world do not require compliance, leaving those countries vulnerable to poorly performing products.

An informed buyer will avoid non-compliant product, instead demanding compliance to one or both of these standards, factually verified by an independent third party test laboratory certificate. Compliance to these standards alone however should be



considered a benchmark or minimum requirement, as there are certain enhanced performance requirements that may be advantageous for some applications.

One example of this is how the SPD performs during an AC overvoltage event.

In both standards referenced above, the requirement is for the SPD to safely disconnect from service during these events, however a better solution is for the SPD to survive such an event, thereby continuing to provide protection to your valuable equipment being protected.

nVent ERICO's TD technology delivers just that, a true step-up in performance for SPDs. Our SPDs with TD technology have been designed to be unaffected by the AC overvoltages applied during testing, while not compromising the clamping performance. This provides them with the ability to survive extreme overvoltage conditions and still be operational afterwards to protect your valuable equipment from subsequent surges and transients.

This extends greatly the life expectancy of the SPD within the most extreme environments, saving maintenance work and reducing operational downtime.

Transient Discriminating Technology

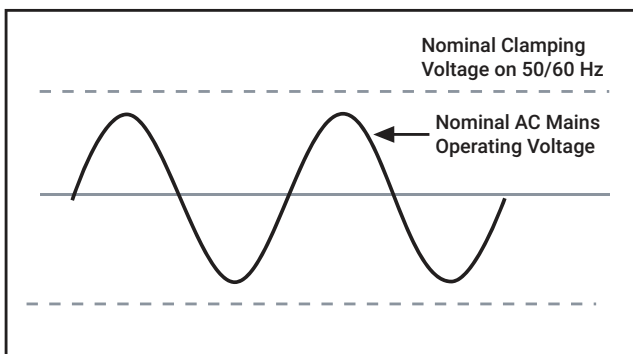

To meet the fundamental requirements of performance, longer service life and greater safety under real world conditions, nVent ERICO has developed Transient Discriminating (TD) Technology.

This quantum leap in technology adds a level of “intelligence” to the Surge Protection Device enabling it to discriminate between sustained abnormal overvoltage conditions (Temporary Over Voltages – TOVs) and true transient or surge events. Not only does this help ensure safe operation under practical application, but it also prolongs the life of the protector since permanent disconnects are not required as a means of achieving internal over-voltage protection.

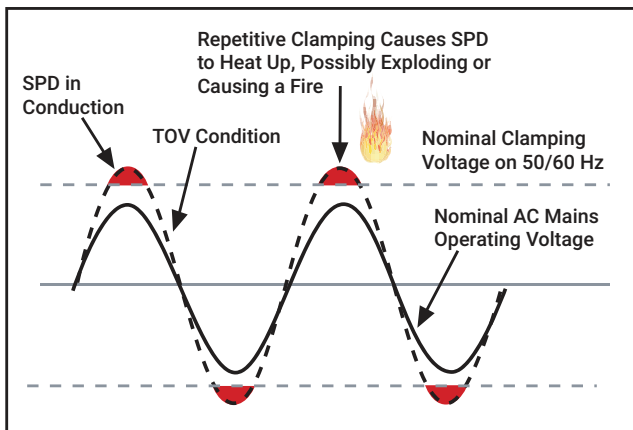

TRADITIONAL TECHNOLOGIES

Conventional SPD technologies utilizing metal oxide varistors and/or silicon avalanche diodes to clamp or limit transient events are susceptible to sustained 50/60 Hz mains over-voltage conditions (TOVs) which often occur during faults to the utility system. Such occurrences present a significant safety hazard when the suppression device attempts to clamp the peak of each half cycle on the mains overvoltage.

This condition can cause the device to rapidly accumulate heat and in turn fail with the possibility of inducing a fire hazard. The diagram shows how a traditional SPD is chosen to have a nominal clamping voltage that is above the peak of the nominal AC mains voltage. However, in the lower diagram, it can be seen that when the AC mains experiences a Temporary Over-Voltage (TOV), the SPD attempts to clamp the over-voltage, and rapidly heats up, resulting in failure, potentially accompanied by fire or explosion.

The Core of TD Technology



The secret to nVent ERICO's Transient Discriminating Technology is its active frequency discrimination circuit. This patented device can discriminate between a temporary over-voltage (TOV) condition and a very fast transient, which is associated with lightning or switching-induced surges. When the transient frequencies are detected, the patented Quick-Switch within TD activates to allow the robust protection to limit the incoming transient. The frequency discriminating circuit that controls the Quick-Switch helps ensure that the SPD device is immune to the effects of a sustained 50 or 60 Hz TOV. This allows the device to keep operating, in order to help provide safe and reliable transient protection, even after an abnormal over-voltage condition has occurred.

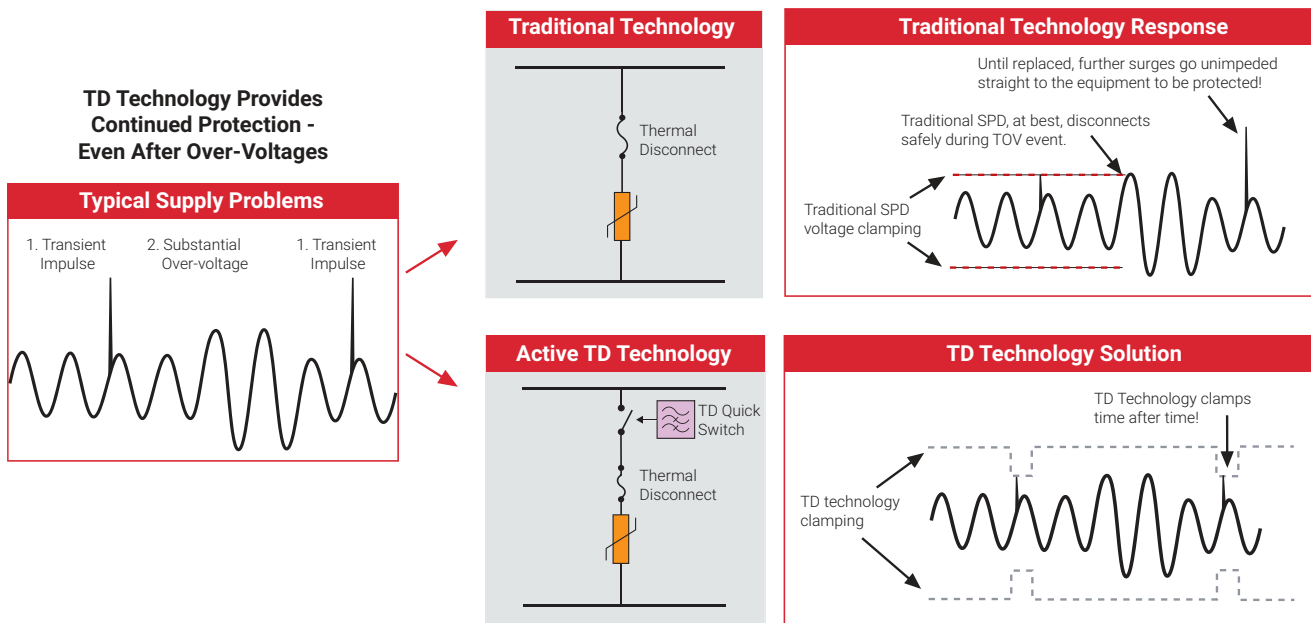

Effectively, TD Technology allows the SPD to have two clamping levels – one well above the peak of a TOV (up to twice its nominal AC voltage!), and the other much lower, to effectively and swiftly clamp lightning transients.

As the explanatory illustration shows, this allows the TD circuit to still remain operational after TOV events, thus continuing to clamp transients and providing a much longer operational life. For example, the IEC 61643-11 standard applies a test of 442 Vac for two hours from Line to Neutral for SPDs intended to operate at 230 Vac. While most SPDs fail safely during this test, nVent ERICO's EDT2 Series SPDs are unaffected by this stringent test, and remain completely operational. The IEC 61643-11 standard calls this Withstand mode, as opposed to Safe Failure mode.

nVent ERICO SPDs that incorporate TD Technology are especially recommended for any site where sustained over-voltages are known to occur, and where failure of traditional SPD technologies cannot be tolerated.

Selection and Application of AC Power System SPDs (IEC System)

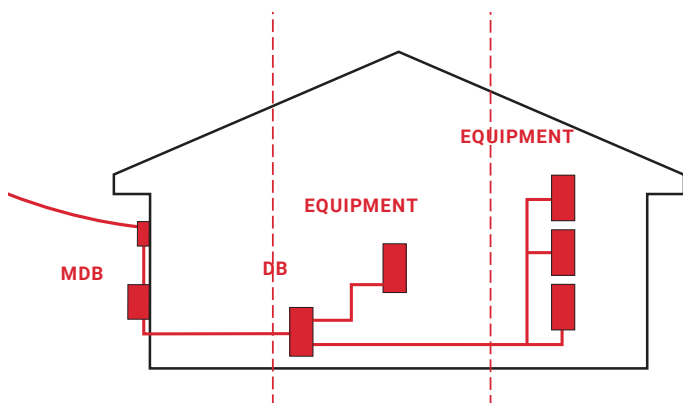

CLASS OF SPD

In the IEC system, SPDs are tested to various Test Classes, intended to assess and assure their suitability for use in different locations and circumstances. Strictly speaking, the Class refers to the type of test, not to the SPD. However, in common usage, SPDs are referred to by their Class. For example, a Class I SPD is an SPD that has been tested to Class I requirements (of a specified severity), and so on.

The Test Classes are as follows:

Class I – Tested with simulated partial conducted lightning current impulses. These SPDs would be used at points of high exposure, such as where the line close to the SPD might be directly struck by lightning, or at the point of entry to a building fitted with a direct strike Lightning Protection System (LPS).

Class II – Tested with shorter duration current impulses. These SPDs would be installed where the surge currents are expected to be less. This could be at the main power entry point of a building in a non-exposed location (surrounded by taller buildings, for example), or at sub-panels within the building.

Class III – Tested with voltage impulses. These SPDs would be installed at equipment to be protected, and are only expected to handle residual voltages surges that “got past” upstream Class I or II SPDs, and the associated small surge currents. Often, for convenience, Class II protectors are used at these locations as well.

In the illustration above, the type of SPDs installed at the Main Distribution Board, Distribution Boards, and the Equipment to be protected would be as follows:

Building Situation	MDB	DB	Equipment
Highly exposed, or fitted with LPS	Class I	Class II	Class III (or II)
Less exposed, no LPS	Class II	Class II	Class III (or II)

There are a number of IEC standards that work together to provide a system of classifying the power system, the over-voltages that can occur at different points in the system, the performance and application of SPDs, and the relative susceptibility of end use equipment to lightning surges. The most directly relevant are the IEC 62305 series standards dealing with both lightning protection and surge protection, and the IEC 61643 series standards covering testing, selection, and application of SPDs.

Fitting SPDs at all three locations may not be necessary, depending on the building size, and wiring length. Generally, SPDs are always fitted at the point of entry, and in smaller equipment rooms may just be, additionally, at the equipment. In larger buildings, spread over multiple floors or large areas, SPDs would usually be provided at the distribution boards, and additionally at sensitive or critical equipment.

SPDs are primarily rated according to how large a surge current magnitude they can handle, and how well they limit the voltage while conducting that surge current. These parameters are

Test Class	Parameter	Description
Class I	Impulse Current, I_{imp}	This current impulse has a 10/350 μs waveform.
Class II	Nominal Discharge Current, I_n	This current impulse has a waveform of 8/20 μs , and is nominal because the SPD has to successfully handle a sequence of 15 of these impulses.
	Maximum Discharge Current, I_{max}	This current impulse has a waveform of 8/20 μs , and is the maximum 8/20 μs impulse the SPD can handle. It is an optional parameter.
Class III	Open circuit voltage of the combination wave generator, U_{oc}	
All Classes	Voltage Protection Level, U_p	

It is possible to test one SPD type at more than one Test Class. SPDs are marked and specified with the parameters they have been successfully tested to.

Selection and Application of AC Power System SPDs (IEC System)

SPD CLASSES AND CATEGORIES

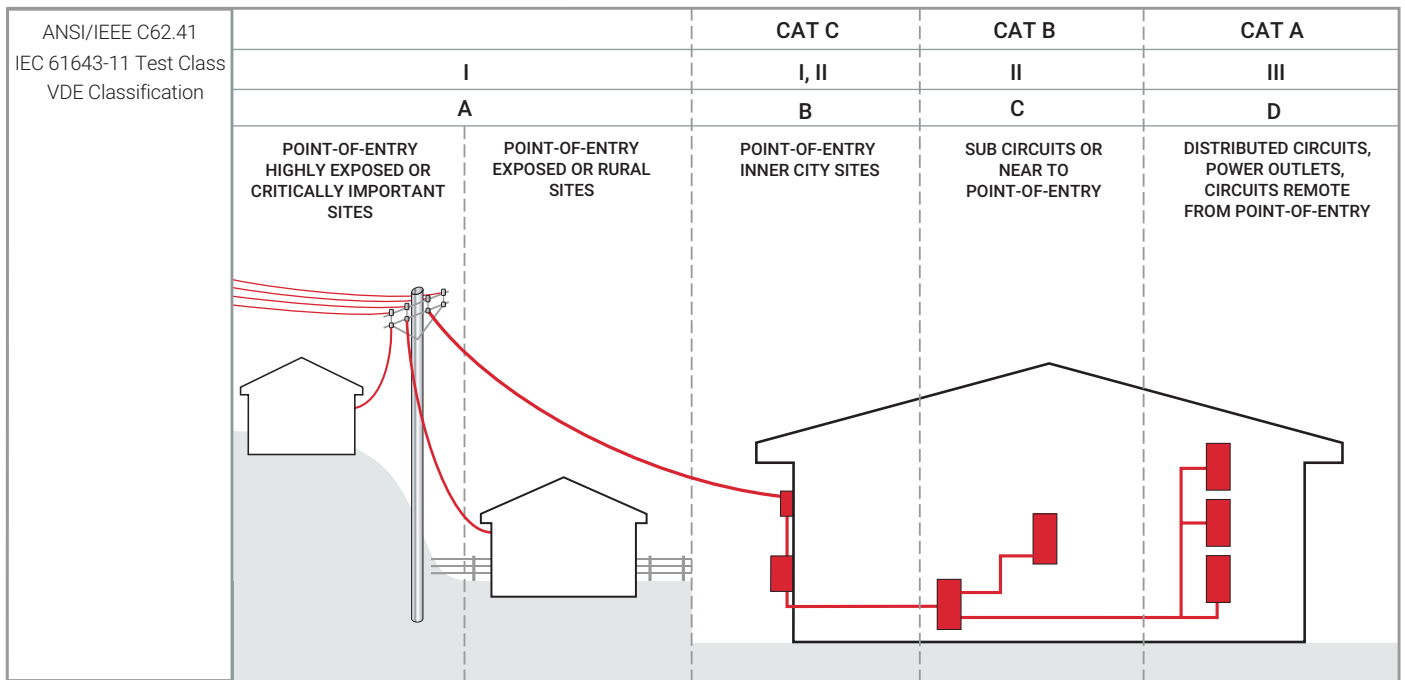

RECOMMENDED PRODUCTS

PRODUCT SERIES	SRF N SERIES			
	DT1 SERIES			
	DT2 SERIES			
	EDT2 SERIES			
	TSF SERIES			

Selection and Application of AC Power System SPDs (IEC System)

Having determined the Class of SPD required, the correct voltage and configuration needs to be determined. The standard IEC 60364-1 details the following system configurations. In the descriptions that follow, U_0 is used for the nominal systems voltage, and U_c is used for the maximum continuous operating voltage (this is a parameter of an SPD).

TN-C System

In this system, the neutral and protective earth conductor are combined in a single conductor throughout the system. This conductor is referred to as a PEN, a "Protective Earth & Neutral". All exposed conductive equipment parts are connected to the PEN.

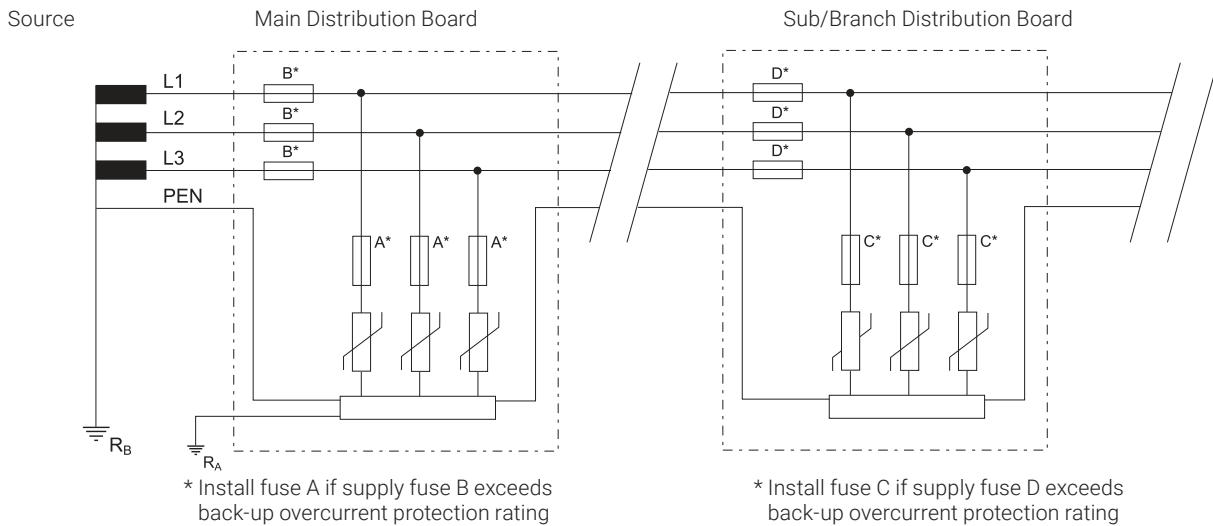

SPDs installed	Description	Example product
Phase to PEN ("3+0")	At least 1.1 x U_0	DT230030R

For example, on a 230 V Ph-N system, Ph-PEN protection should have a U_c rating of at least 255 V. Generally an SPD with a U_c rating of at least 275 V would be selected for 220 to 240 V systems. Often, to allow for power supply voltage fluctuations, a U_c of at least 1.3 x U_0 is recommended, such as a U_c of 300 V for a 230 V system, or nVent ERICO's TD technology would be chosen.

TN-S System

In this system, a separate neutral and protective earth conductor are run throughout. The Protective Earth (PE) conductor is normally a separate conductor, but can also be the metallic sheath of the power cable. All exposed conductive equipment parts are connected to the PE conductor.

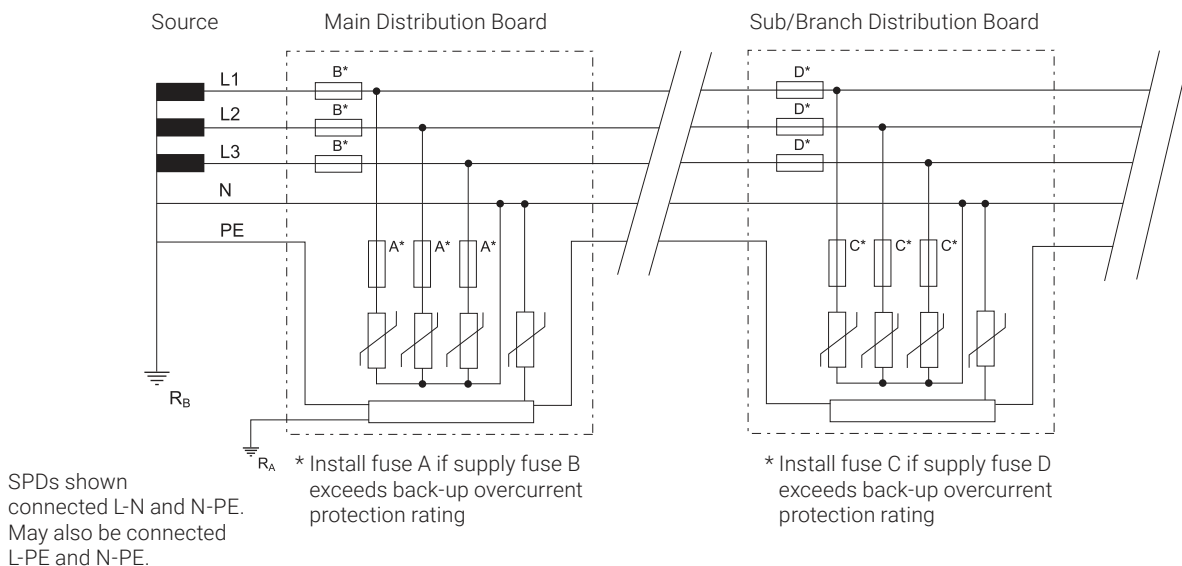

Selection and Application of AC Power System SPDs (IEC System)

SPDs installed	Description	Example product
Phase to PE ("4+0"), or	At least 1.1 x Uoc	DT230040R
Phase-N, and N-PE ("3+1")		DT230031R

For example, on a 230 V Ph-N system, Ph-PE (or Ph-N) protection should have a Uc rating of at least 255 V. Generally an SPD with a Uc rating of at least 275 V would be selected for 220 to 240 V systems. Often, to allow for power supply voltage fluctuations, a Uc of at least 1.3 x Uo is recommended, such as a Uc of 300 V for a 230 V system, or nVent ERICO's TD technology would be chosen.

TN-C-S System

In this system, the supply is configured as per TN-C, while the downstream installation is configured as per TN-S. The combined PEN conductor typically occurs between the substation and the entry point into the building, and earth and neutral are separated in the Main Distribution Board. This system is also known as Protective Multiple Earthing (PME) or Multiple Earthed Neutral (MEN). The supply PEN conductor is earthed at a number of points throughout the network and generally as close to the consumer's point-of-entry as possible.

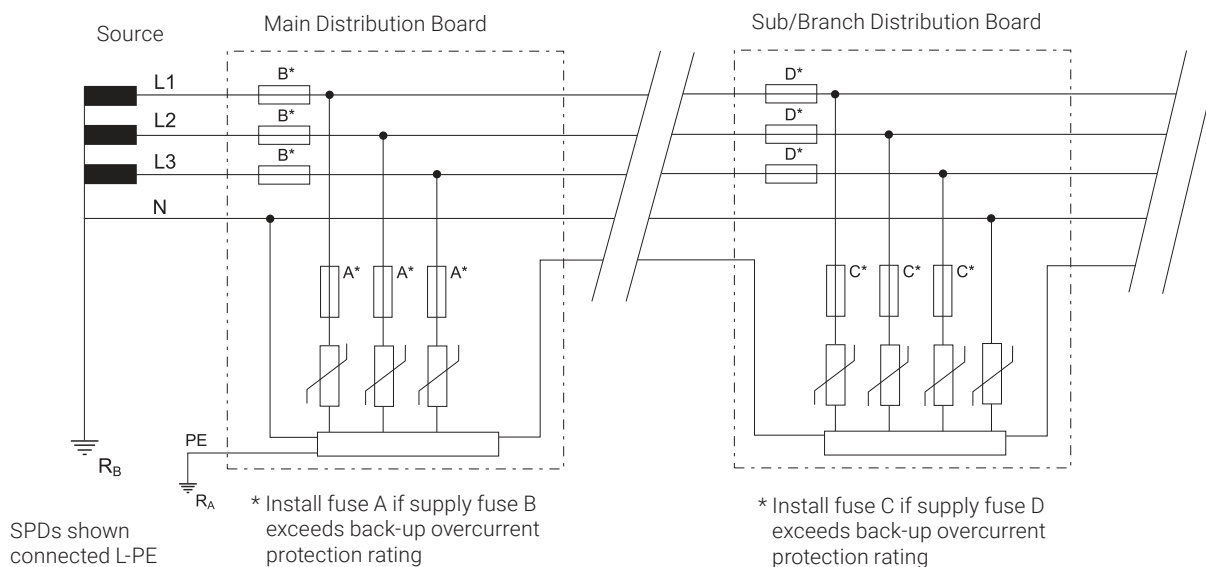

SPDs shown connected L-PE and N-PE.

May also be connected L-N and N-PE.

SPDs INSTALLED	Description	Example product
MDB: Phase to PEN ("3+0")		
DB: Phase to PEN ("4+0"), or	At least 1.1 x Uo	DT130030R, DT230040R, DT230031R
Phase-N, and N-PE ("3+1")		

For example, on a 230 V Ph-N system, Ph-PE (or Ph-N) protection should have a Uc rating of at least 255 V. Generally an SPD with a Uc rating of at least 275 V would be selected for 220 to 240 V systems. Often, to allow for power supply voltage fluctuations, a Uc of at least 1.3 x Uo is recommended, such as a Uc of 300 V for a 230 V system, or nVent ERICO's TD technology would be chosen.

Selection and Application of AC Power System SPDs (IEC System)

TT SYSTEM

A system having one point of the source of energy earthed and the exposed conductive parts of the installation connected to independent earthed electrodes. The incoming supply neutral is not earthed at the main distribution board.

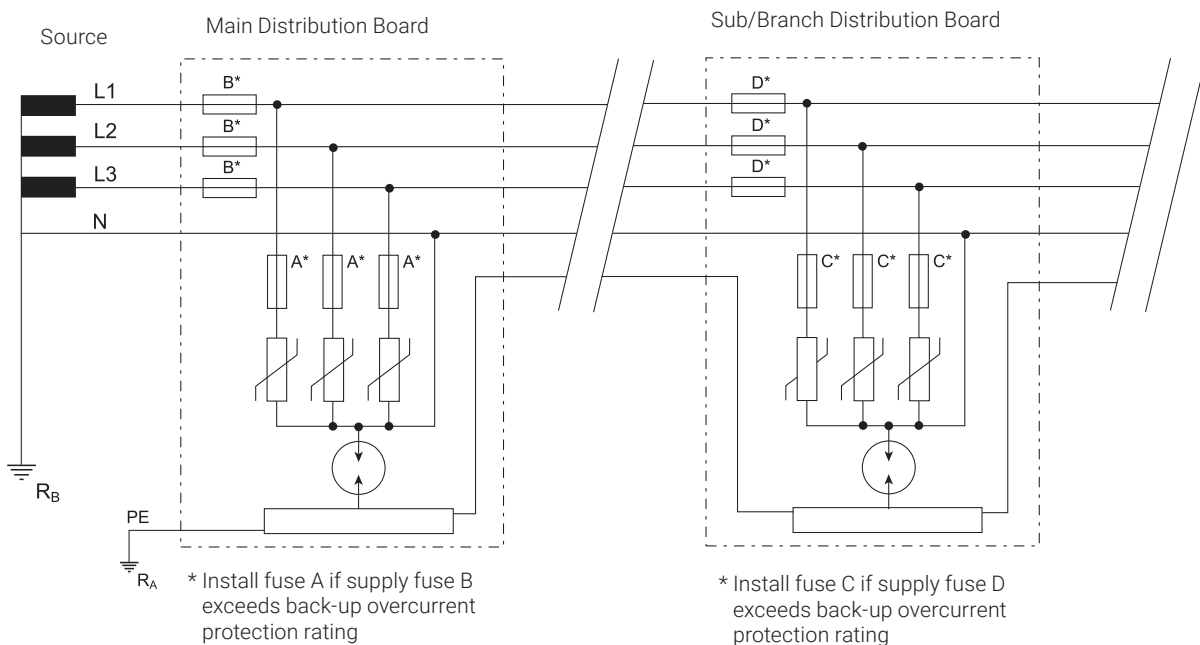

SPDs installed	Description	Example product
Phase to N, N-PE ("3+1")	At least 1.1 x U_{oc}	DT130031R, DT230031R

For example, on a 230 V Ph-N system, Ph-N protection should have a U_c rating of at least 255 V. Generally an SPD with a U_c rating of at least 275 V would be selected for 220 to 240 V systems. Often, to allow for power supply voltage fluctuations, a U_c of at least 1.3 x U_o is recommended, such as a U_c of 300 V for a 230V system, or nVent ERICO's TD technology would be chosen.

In the TT system, in order for overcurrent protective devices (fuses and circuit breakers) to operate in the intended manner, it is important that SPDs must not connect directly from phase to protective ground, but from phase to neutral and neutral to ground. Therefore, the Neutral-to-PE SPD carries both the PE to neutral impulse current and the PE to phase impulse currents. This SPD is recommended to be a GDT (Gas Discharge Tube) due to their generally superior energy handling characteristics.

Selection and Application of AC Power System SPDs (IEC System)

IT SYSTEM

A system having no direct connection between live parts and earth, but all exposed conductive parts of the installation being connected to independent earthed electrodes. The source is either floating or earthed through a high impedance (to limit fault currents). This means that during a Phase to Earth fault, the systems continues to operate. This is detected, and maintenance efforts commenced to rectify the fault. However, during this time, the Phase to Earth voltage rises to the usual Line to Line voltage, and installed SPDs must withstand this during this time. Most installed IT systems do not utilise a neutral conductor - equipment is powered from line to line. The IT system is typically used in older installations in countries such as Norway and France. It is also used in special applications, such as intensive care wards of hospitals and special industrial applications.

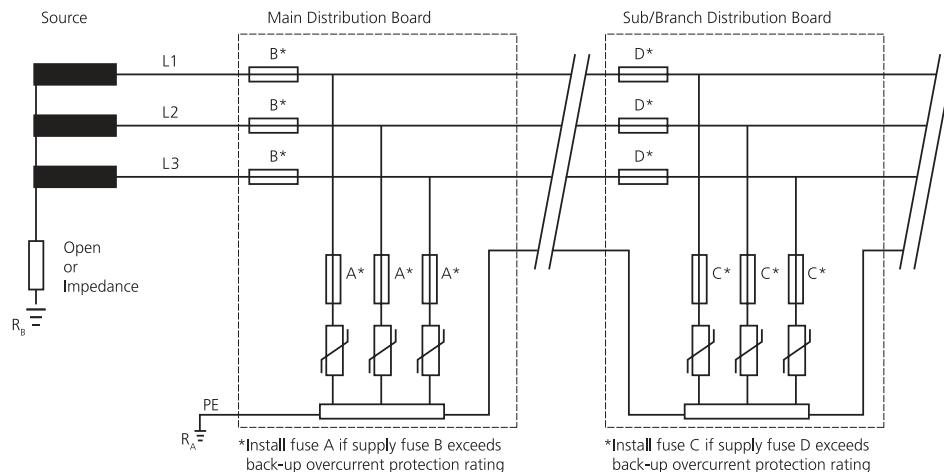

SPDs installed	Description	Example product
Phase to PEN ("3+0")	At least 1.73 x U _o	DT230030R

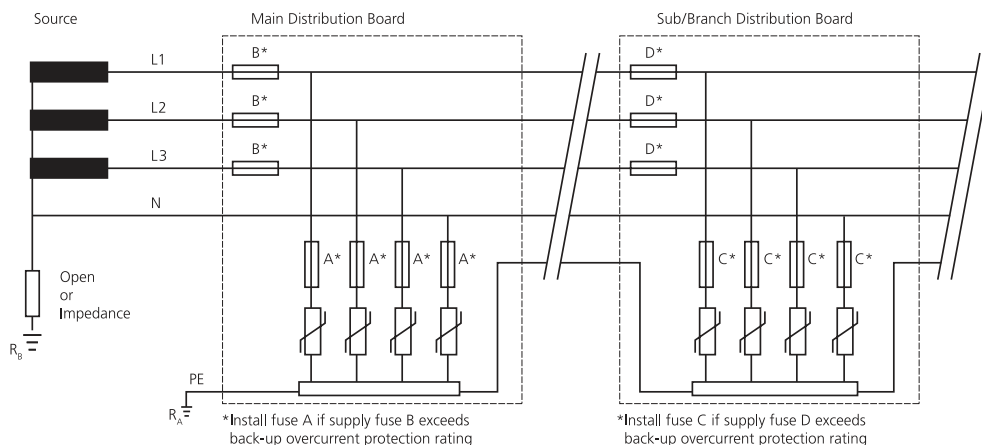

SPDs installed	Description	Example product
Phase to PEN ("4+0")	At least 1.73 x U _o	DT130040R, DT230040R

For example, on a 230 V Ph-N system, Ph-PE and N-PE protection should have a U_c rating of 440 V (allowing for the L-L voltage and a 10% tolerance). Often an additional safety margin is applied, to allow for instabilities that can occur in the ungrounded IT system, such as a U_c of 480 V.

Products

CLASS I / CLASS II SURGE PROTECTION

DT1

The DIN Rail mounted DT1 family of SPDs provide reliable and efficient protection against voltage transients within the IEC Class I & II and UL Type 1 & 2 environments. Tested and independently certified to the IEC (via VDE) and UL standards, the DT1 Series provides a range of safety and performance features for the harshest environments and suitable for protection within a wide range of applications.

DT2

The DIN Rail mounted DT2 family provides many of the same benefits as the DT1 Series but is specifically designed to fit within the parameters of IEC Class II and UL Type 2 environments. Targeting the Class II / Type 2 classification allows the system designer to effectively select the correct coordinated protection while keeping total project costs in check.

EDT2

The DIN Rail mounted EDT2 family of SPDs provide reliable protection against voltage transients within the IEC Class II and UL Type 2 environments. In addition, nVent ERICO's Transient Discriminating (TD) technology ensures continued operation during and after sustained and abnormal over-voltage events. Tested and independently certified to the IEC (via VDE) and UL standards, the EDT2 Series provides a range of safety and performance features for the harshest environments and suitable for protection within a wide range of applications. The EDT2 Series provides extended service life in the harshest of environments, ensuring your equipment and systems are kept safe and operational through extreme abnormal voltage conditions.



Products

SURGE FILTERS



SRF

The SRF (Surge Reduction Filters) product family combines high-energy surge diversion with surge filtering, making them ideal for primary service protection applications. Their efficient low pass filtering stage dramatically reduces the rate-of-voltage rise and the let-through voltage thereby substantially reducing the risk of physical equipment damage. They incorporate TD technology making them robust against AC power system temporary overvoltages, and their standards compliance to IEC 61643-11 Class I & Class II ensure maximum product performance with maximum product safety.

TSF

The Transient Surge Filter (TSF) product family combines nVent ERICO's Transient Discriminating (TD) technology with a low pass filter to protect against transient events and attenuate small signal RFI/EMI noise problems. Perfect for PLC controllers, SCADA systems, motor control centers, and other similar applications, the TSF also features serviceable surge modules and a compact form factor. The TSF range of products are certified to UL 1449 4th Edition, UL 1283 5th Edition (EMI Filtering), and IEC 61643-11 Class II.

DATA / SIGNAL PROTECTION

Lightning or induced surges can destroy or compromise signal communications systems and data. nVent ERICO offers multiple series of data and signal surge protection devices designed to provide transient protection for equipment from induced surges. These are also well-suited to the protection of industrial equipment and are compact in size, while offering high surge carrying capacity. nVent ERICO data and signal surge protection offers a complete solution to eliminate damage, downtime, and power disruption..



Surge Protection Product Selection

The various product solutions available are listed below. The basic division is into power protection and signal protection. Power protectors are further divided into shunt protection and series (filtering) protection. Signal protectors are generally divided by connector types and application.

Power Protection - Dinrail Test Class 1 and 2 Protectors

Shunt protection for power circuits

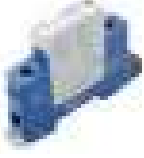
(E)DTX YYZ (R) 	(E)DTX = PRODUCT FAMILY DT1 = Dinrail Test Class 1 DT2 = Dinrail Test Class 2 EDT2 = Enhanced Dinrail Test Class 2	YYY = VOLTAGE 75 = 75 V 150 = 150 V 300 = 300 V 350 = 350 V 480 = 480 V 550 = 550 V (EDT2 only) 750 = 750 V 880 = 880 V (EDT2 only)	ZZ = MODE 10 = 1 + 0 20 = 2 + 0 30 = 3 + 0 40 = 4 + 0 11 = 1 + 1 31 = 3 + 1	R = REMOTE CONTACTS
SGTX YY (R) 	SGTX = PRODUCT FAMILY SGT1 = Spark Gap Test Class 1 SGT2 = Spark Gap Test Class 2	YY = SURGE RATING 40 = 40 kA In [T2] 50 = 50kA Iimp [T1]	R = REMOTE CONTACTS (SGT240R only)	

Power Protection – Transient Surge Filters

Series protection for power circuits (6 A to 20 A)

TSF XXA YYYV 	TSF = PRODUCT FAMILY	XX = LINE CURRENT 6 = 6 A 20 = 20 A	YYY = VOLTAGE 24 = 24 V (6 A only) 120 = 120 V 240 = 240 V
---	-----------------------------	--	--

Power Protection – Surge Reduction Filters

Series protection for power circuits (63 A to 800 A)

SRF XXXA N 	SRF = PRODUCT FAMILY	XXX = LINE CURRENT 63 = 63 A 125 = 125 A 250 = 250 A 500 = 500 A 800 = 800 A	N = N SERIES
--	-----------------------------	--	---------------------

Signal Protection – Universal Transient Barriers

General purpose signal protection

UTB XXX SP 	UTB = PRODUCT FAMILY	XXX = VOLTAGE 5 = 5 V 15 = 15 V 30 = 30 V 60 = 60 V 110 = 110 V	S = SINGLE PAIR
--	-----------------------------	---	------------------------

Telephone line protection

UTBSA 	UTB = PRODUCT FAMILY	SA = TELEPHONE
---	-----------------------------	-----------------------

Surge Protection Product Selection

Signal Protection – Coaxial Surge Protection

General purpose coaxial cable protection

CSP1 XXX YYY 	CSP1 = PRODUCT FAMILY	XXX = CONNECTOR NB =N type, F-F bulkhead NMF =N type, male-female BNC = BNC type, male-female SMA = SMA type, male-female	YYY = MODE 90 =90 V 600 = 600 V
--	------------------------------	--	--



Signal Protection – High Speed Protection

High Speed twisted pair Krone block protection

HSP 10 K XXX 	HSP = PRODUCT FAMILY	10 = 10 PAIR	K = KRONE BLOCK	XXX = VOLTAGE 12 = 12 V 36 = 36 V 72 = 72 V 230 = 230 V
--	-----------------------------	---------------------	------------------------	--

Signal Protection – Subscriber Line Protection

General twisted pair Krone block protection

SLP 1 RJ11 A 	SLP = PRODUCT FAMILY	1 = 1 PAIR	RJ11A = RJ11 CONNECTOR	
SLP 10 K1F 	SLP = product family	10 = 10 pair	K = Krone block	1F = Fail Safe

Signal Protection – Closed Circuit TV

Coaxial Cable CCTV

CCTV 12 	CCTV = PRODUCT FAMILY	12 = voltage
---	------------------------------	---------------------

Signal Protection – Local Area Network

General Purpose RJ45 protection

LAN RJ45 C6P 	LAN = PRODUCT FAMILY	RJ45 = connector	C6P = Category 6 Protection
--	-----------------------------	-------------------------	------------------------------------

DT and EDT SPD Features

Packed with features and benefits for the user, the DT and EDT line from nVent ERICO represents the latest in product design, development and testing.



ADVANCED DESIGN AVOIDS FUSING IN MANY INSTALLATIONS

SPD STATUS INDICATION

ALARM CONTACTS ALLOW REMOTE STATUS MONITORING



CLIP LOCKS MODULE IN PLACE FOR VIBRATION RESISTANCE



CONVENIENT MODULE AND BASE DESIGN



LOCK BACK CLIP MAKES FOR EASY INSTALLATION



KEYING MECHANISM ENSURES CORRECT MODULE



RUGGED CONNECTION TO BASE HANDLES HIGH SURGE CURRENT

DT1 Din Rail Surge Protection Class I+II, 1+0 Mode

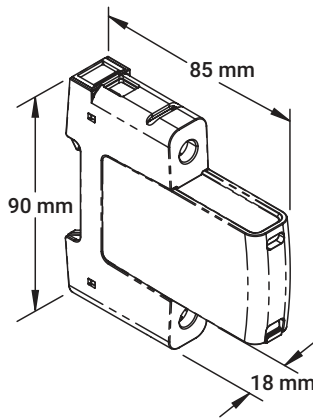

Features

- Compact, yet high surge rated pluggable design, using minimum DIN rail width
- External back-up fuse is not required up to 315 A
- Retaining clip ensures enhanced vibration and shock resistance performance
- Red/Green status indication and change-over contacts standard for remote monitoring

Certification Details: IEC 61643-11 Class I+II, EN 61643-11 Type 1+2, UL 1449, 4th Edition Type 1CA

Complies with: IEC 61643-11:2011, EN 61643-11:2012, UL 1449, 4th Edition, CSA C22.2 No. 269-4

Protection Modes: L-PE, N-PE (only TN-S), L-PEN, L-N



Part Number	DT17510R	DT130010R	DT148010R
IEC Electrical			
Nominal AC Voltage (50/60Hz) U_o / U_n	60V	240V	400V
Maximum Continuous Operating Voltage (AC) U_c	75V	300V	480V
Nominal Discharge Current (8/20 μ s) I_n	12.5 kA	12.5 kA	10 kA
Maximum Discharge Current (8/20 μ s) I_{max}	50 kA	50 kA	50 kA
Impulse Discharge Current (10/350 μ s) I_{imp}	12.5 kA	12.5 kA	10 kA
Specific Energy W/R	39 kJ/ Ω	39 kJ/ Ω	25 kJ/ Ω
Voltage Protection Level Up	700V	1400V	2000V
Response Time tA	< 25 ns		
Back-Up Fuse (max)	315A / 250A gG		
Short-Circuit Current Rating (AC) ISCCR	25 kA / 50 kA		
TOV Withstand 5s U_T	114V	337V	581V
TOV 120 min U_T /mode	114V/withstand	442V/safe fail	762V/safe fail
Number of Ports	1		
UL Electrical			
Maximum Continuous Operating Voltage (AC) MCOV	75V	300V	480V
Voltage Protection Rating VPR	400V	900V	1500V
Nominal Discharge Current (8/20 μ s) I_n	20 kA	20 kA	20 kA
Short-Circuit Current Rating (AC) SCCR	100 kA	150 kA	200 kA
Mechanical			
Operating Temperature Range T_a	-40° C to +70° C [-40° F to +158° F]		
Terminal Screw Torque M_{max}	39.9 lbf-in [4.5 Nm]		
Conductor Cross Section (max)	35mm ² (Solid) / 25mm ² (Stranded) 2 AWG (Solid) / 4 AWG (Stranded)		
Mounting	35 mm DIN Rail, EN 60715		
Housing Material	Thermoplastic: Extinguishing Degree UL 94 V-0		
Thermal Protection	Yes		
Operating State / Fault Indication	Green Flag / Not Green Flag		
Remote Contacts (RC)	Yes		
RC Switching Capacity	AC: 250V/1A, 125V/1A; DC: 48V/0.5A, 24V/0.5A, 12V/0.5A		
RC Conductor Cross Section (max)	1.5mm ² (Solid) / 16 AWG (Solid)		
Single Unit Weight pounds	0.371	0.402	0.446
Single Unit Weight grams	168	182	202

DT1 DIN Rail Surge Protection Class I+II, 2+0 Mode

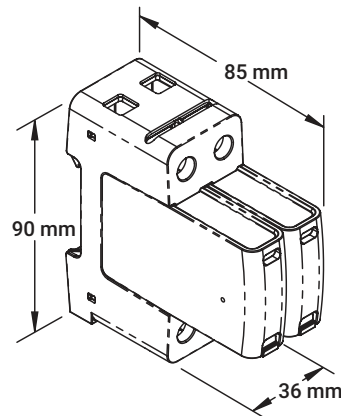

Features

- Compact, yet high surge rated pluggable design, using minimum DIN rail width
- External back-up fuse is not required up to 315 A
- Retaining clip ensures enhanced vibration and shock resistance performance
- Red/Green status indication and change-over contacts standard for remote monitoring

Certification Details: IEC 61643-11 Class I+II
EN 61643-11 Type 1+2
UL 1449, 4th Edition Type 1CA

Complies with: IEC 61643-11:2011
EN 61643-11:2012
UL 1449, 4th Edition
CSA C22.2 No. 269-4

Protection Modes: L-PE, N-PE



Part Number	DT130020R
IEC Electrical	
Nominal AC Voltage (50/60Hz) U_o / U_n	240V
Maximum Continuous Operating Voltage (AC) U_c	300V
Nominal Discharge Current (8/20 μ s) I_n	12.5 kA
Maximum Discharge Current (8/20 μ s) I_{max}	50 kA
Impulse Discharge Current (10/350 μ s) I_{imp}	12.5 kA
Specific Energy W/R	39 kJ/ Ω
Voltage Protection Level Up	1400V
Response Time t_A	< 25 ns
Back-Up Fuse (max)	315A / 250A gG
Short-Circuit Current Rating (AC) ISCCR	25 kA / 50 kA
TOV Withstand 5s U_T	337V
TOV 120 min U_T /mode	442V/safe fail
Number of Ports	1
UL Electrical	
Maximum Continuous Operating Voltage (AC) MCOV	300V
Voltage Protection Rating VPR	900V
Nominal Discharge Current (8/20 μ s) I_n	20 kA
Short-Circuit Current Rating (AC) SCCR	150 kA
Mechanical	
Operating Temperature Range T_a	-40° F to +158° F [-40° C to +70° C]
Terminal Screw Torque M_{max}	39.9 lbf-in [4.5 Nm]
Conductor Cross Section (max)	35mm ² (Solid) / 25mm ² (Stranded) 2 AWG (Solid) / 4 AWG (Stranded)
Mounting	35 mm DIN Rail, EN 60715
Housing Material	Thermoplastic: Extinguishing Degree UL 94 V-0
Thermal Protection	Yes
Operating State / Fault Indication	Green Flag / Not Green Flag
Remote Contacts (RC)	Yes
RC Switching Capacity	AC: 250V/1A, 125V/1A; DC: 48V/0.5A, 24V/0.5A, 12V/0.5A
RC Conductor Cross Section (max)	1.5mm ² (Solid) / 16 AWG (Solid)
Single Unit Weight pounds	0.779
Single Unit Weight grams	353

DT1 DIN Rail Surge Protection Class I+II, 3+0 Mode

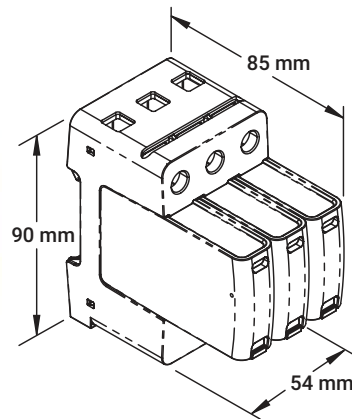

Features

- Compact, yet high surge rated pluggable design, using minimum DIN rail width
- External back-up fuse is not required up to 315 A
- Retaining clip ensures enhanced vibration and shock resistance performance
- Red/Green status indication and change-over contacts standard for remote monitoring

Certification Details: IEC 61643-11 Class I+II
EN 61643-11 Type 1+2
UL 1449, 4th Edition Type 1CA

Complies with: IEC 61643-11:2011
EN 61643-11:2012
UL 1449, 4th Edition
CSA C22.2 No. 269-4

Protection Modes: L-PE, N-PE



Part Number	DT130030R	DT148030R
IEC Electrical		
Nominal AC Voltage (50/60Hz) U_o / U_n	240V	400V
Maximum Continuous Operating Voltage (AC) U_c	300V	480V
Nominal Discharge Current (8/20 μ s) I_n	12.5 kA	10 kA
Maximum Discharge Current (8/20 μ s) I_{max}	50 kA	50 kA
Impulse Discharge Current (10/350 μ s) I_{imp}	12.5 kA	10 kA
Specific Energy W/R	39 kJ/ Ω	25 kJ/ Ω
Voltage Protection Level Up	1400V	2000V
Response Time t_A	< 25 ns	
Back-Up Fuse (max)	315A / 250A gG	
Short-Circuit Current Rating (AC) ISCCR	25 kA / 50 kA	
TOV Withstand 5s U_T	337V	581V
TOV 120 min U_T /mode	442V/safe fail	762V/safe fail
Number of Ports	1	
UL Electrical		
Maximum Continuous Operating Voltage (AC) MCOV	300V	480V
Voltage Protection Rating VPR	900V	1500V
Nominal Discharge Current (8/20 μ s) I_n	20 kA	20 kA
Short-Circuit Current Rating (AC) SCCR	150 kA	200 kA
Mechanical		
Operating Temperature Range T_a	-40° F to +158° F [-40° C to +70° C]	
Terminal Screw Torque M_{max}	39.9 lbf·in [4.5 Nm]	
Conductor Cross Section (max)	35mm ² (Solid) / 25mm ² (Stranded) 2 AWG (Solid) / 4 AWG (Stranded)	
Mounting	35 mm DIN Rail, EN 60715	
Housing Material	Thermoplastic: Extinguishing Degree UL 94 V-0	
Thermal Protection	Yes	
Operating State / Fault Indication	Green Flag / Not Green Flag	
Remote Contacts (RC)	Yes	
RC Switching Capacity	AC: 250V/1A, 125V/1A; DC: 48V/0.5A, 24V/0.5A, 12V/0.5A	
RC Conductor Cross Section (max)	1.5mm ² (Solid) / 16 AWG (Solid)	
Single Unit Weight pounds	1.133	1.266
Single Unit Weight grams	514	574

DT1 DIN Rail Surge Protection Class I+II, 4+0 Mode

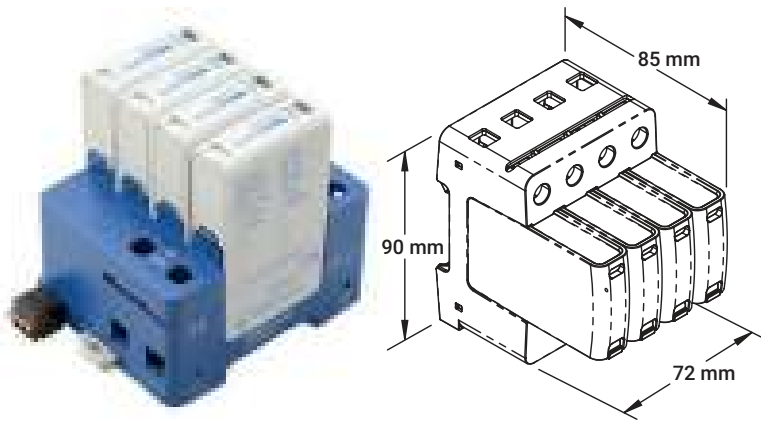

Features

- Compact, yet high surge rated pluggable design, using minimum DIN rail width
- External back-up fuse is not required up to 315 A
- Retaining clip ensures enhanced vibration and shock resistance performance
- Red/Green status indication and change-over contacts standard for remote monitoring

Certification Details: IEC 61643-11 Class I+II
EN 61643-11 Type 1+2
UL 1449, 4th Edition Type 1CA

Complies with: IEC 61643-11:2011
EN 61643-11:2012
UL 1449, 4th Edition
CSA C22.2 No. 269-4

Protection Modes: L-PE, N-PE



Part Number	DT130040R	DT148040R
IEC Electrical		
Nominal AC Voltage (50/60Hz) U_o / U_n	240V	400V
Maximum Continuous Operating Voltage (AC) U_c	300V	480V
Nominal Discharge Current (8/20 μ s) I_n	12.5 kA	10 kA
Maximum Discharge Current (8/20 μ s) I_{max}	50 kA	50 kA
Impulse Discharge Current (10/350 μ s) I_{imp}	12.5 kA	10 kA
Specific Energy W/R	39 kJ/ Ω	25 kJ/ Ω
Voltage Protection Level U_p	1400V	2000V
Response Time t_A	< 25 ns	
Back-Up Fuse (max)	315A / 250A gG	
Short-Circuit Current Rating (AC) ISCCR	25 kA / 50 kA	
TOV Withstand 5s U_T	337V	581V
TOV 120 min U_T /mode	442V/safe fail	762V/safe fail
Number of Ports	1	
UL Electrical		
Maximum Continuous Operating Voltage (AC) MCOV	300V	480V
Voltage Protection Rating VPR	900V	1500V
Nominal Discharge Current (8/20 μ s) I_n	20 kA	20 kA
Short-Circuit Current Rating (AC) SCCR	150 kA	200 kA
Mechanical		
Operating Temperature Range T_a	-40° F to +158° F [-40° C to +70° C]	
Terminal Screw Torque M_{max}	39.9 lbf-in [4.5 Nm]	
Conductor Cross Section (max)	35mm ² (Solid) / 25mm ² (Stranded) 2 AWG (Solid) / 4 AWG (Stranded)	
Mounting	35 mm DIN Rail, EN 60715	
Housing Material	Thermoplastic: Extinguishing Degree UL 94 V-0	
Thermal Protection	Yes	
Operating State / Fault Indication	Green Flag / Not Green Flag	
Remote Contacts (RC)	Yes	
RC Switching Capacity	AC: 250V/1A, 125V/1A; DC: 48V/0.5A, 24V/0.5A, 12V/0.5A	
RC Conductor Cross Section (max)	1.5mm ² (Solid) / 16 AWG (Solid)	
Single Unit Weight pounds	1.519	1.696
Single Unit Weight grams	689	769

DT1 DIN Rail Surge Protection Class I+II, 1+1 Mode

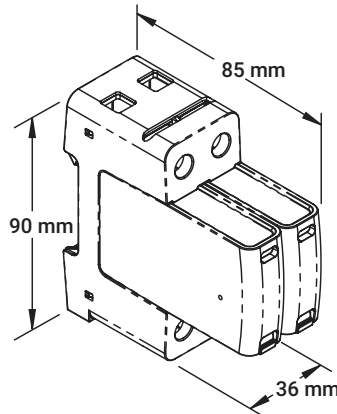

Features

- Compact, yet high surge rated pluggable design, using minimum DIN rail width
- External back-up fuse is not required up to 315 A
- Retaining clip ensures enhanced vibration and shock resistance performance
- Red/Green status indication and change-over contacts standard for remote monitoring

Certification Details:

IEC 61643-11 Class I+II
EN 61643-11 Type 1+2
UL 1449, 4th Edition Type 1CA
IEC 61643-11:2011
EN 61643-11:2012
UL 1449, 4th Edition
CSA C22.2 No. 269-4
L-N, N-PE

Complies with:

Protection Modes:

Part Number	DT17511R	DT130011R
IEC Electrical		
Nominal AC Voltage (50/60Hz) U_o / U_n	60V	240V
Maximum Continuous Operating Voltage (AC) L-N U_c	75V	300V
Maximum Continuous Operating Voltage (AC) N-PE U_{c0}	305V	305V
Nominal Discharge Current (8/20 μ s) L-N / N-PE I_n	12.5 kA / 50 kA	
Maximum Discharge Current (8/20 μ s) L-N / N-PE I_{max}	50 kA / 100 kA	
Impulse Discharge Current (10/350 μ s) L-N / N-PE I_{imp}	12.5 kA / 50 kA	
Specific Energy L-N / N-PE W/R	39 kJ/ Ω / 625 kJ/ Ω	
Voltage Protection Level L-N / N-PE U_p	700V / 1500V	1400V / 1500V
Follow Current Interrupt Rating (N-PE) I_{fi}	100 ARMS	
Response Time L-N / N-PE t_A	< 25 ns / < 100 ns	
Back-Up Fuse (max)	315A / 250A gG	
Short-Circuit Current Rating (AC) ISCCR	25 kA / 50 kA	
TOV Withstand 5s L-N U_T	114V	337V
TOV 120 min L-N UT/mode	114V/withstand	442V/safe fail
TOV Withstand 200 ms N-PE U_T	1200V	
Number of Ports	1	
UL Electrical		
Maximum Continuous Operating Voltage (AC) L-N / N-PE MCOV	75V / 305V	300V / 305V
Voltage Protection Rating L-N / N-PE VPR	400V / 1500V	900V / 1500V
Nominal Discharge Current (8/20 μ s) L-N / N-PE I_n	20 kA / 20 kA	
Short-Circuit Current Rating (AC) L-N SCCR	100 kA	150 kA
Mechanical		
Operating Temperature Range T_a	-40° F to +158° F [-40° C to +70° C]	
Terminal Screw Torque M_{max}	39.9 lbf·in [4.5 Nm]	
Conductor Cross Section (max)	35mm ² (Solid) / 25mm ² (Stranded) 2 AWG (Solid) / 4 AWG (Stranded)	
Mounting	35 mm DIN Rail, EN 60715	
Housing Material	Thermoplastic: Extinguishing Degree UL 94 V-0	
Thermal Protection	Yes	
Operating State / Fault Indication	Green Flag / Not Green Flag	
Remote Contacts (RC)	Yes	
RC Switching Capacity	AC: 250V/1A, 125V/1A; DC: 48V/0.5A, 24V/0.5A, 12V/0.5A	
RC Conductor Cross Section (max)	1.5mm ² (Solid) / 16 AWG (Solid)	
Single Unit Weight pounds	0.715	0.746
Single Unit Weight grams	324	338

DT1 DIN Rail Surge Protection Class I+II, 3+1 Mode

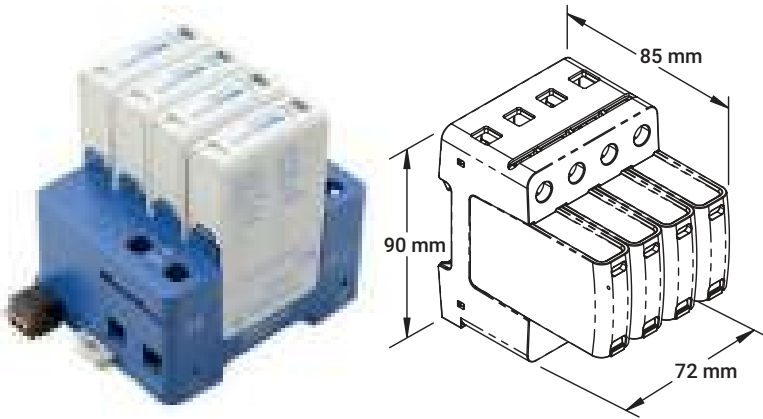

Features

- Compact, yet high surge rated pluggable design, using minimum DIN rail width
- External back-up fuse is not required up to 315 A
- Retaining clip ensures enhanced vibration and shock resistance performance
- Red/Green status indication and change-over contacts standard for remote monitoring

Certification Details:	IEC 61643-11 Class I+II EN 61643-11 Type 1+2 UL 1449, 4th Edition Type 1CA
Complies with:	IEC 61643-11:2011 EN 61643-11:2012 UL 1449, 4th Edition CSA C22.2 No. 269-4
Protection Modes:	L-N, N-PE



Part Number	DT130031R
IEC Electrical	
Nominal AC Voltage (50/60Hz) U_o / U_n	240V
Maximum Continuous Operating Voltage (AC) L-N U_c	300V
Maximum Continuous Operating Voltage (AC) N-PE U_c	305V
Nominal Discharge Current (8/20 μ s) L-N / N-PE I_n	12.5 kA / 50 kA
Maximum Discharge Current (8/20 μ s) L-N / N-PE I_{max}	50 kA / 100 kA
Impulse Discharge Current (10/350 μ s) L-N / N-PE I_{imp}	12.5 kA / 50 kA
Specific Energy L-N / N-PE W/R	39 kJ/ Ω / 625 kJ/ Ω
Voltage Protection Level L-N / N-PE U_p	1400V / 1500V
Follow Current Interrupt Rating (N-PE) I_{fi}	100 ARMS
Response Time L-N / N-PE tA	< 25 ns / < 100 ns
Back-Up Fuse (max)	315A / 250A gG
Short-Circuit Current Rating (AC) ISCCR	25 kA / 50 kA
TOV Withstand 5s L-N U_T	337V
TOV 120 min L-N U_T /mode	442V/safe fail
TOV Withstand 200 ms N-PE U_T	1200V
Number of Ports	1
UL Electrical	
Maximum Continuous Operating Voltage (AC) L-N / N-PE MCOV	300V / 305V
Voltage Protection Rating L-N / N-PE VPR	900V / 1500V
Nominal Discharge Current (8/20 μ s) L-N / N-PE I_n	20 kA / 20 kA
Short-Circuit Current Rating (AC) L-N SCCR	150 kA
Mechanical	
Operating Temperature Range T_a	-40° F to +158° F [-40° C to +70° C]
Terminal Screw Torque M_{max}	39.9 lbf-in [4.5 Nm]
Conductor Cross Section (max)	35mm ² (Solid) / 25mm ² (Stranded) 2 AWG (Solid) / 4 AWG (Stranded)
Mounting	35 mm DIN Rail, EN 60715
Housing Material	Thermoplastic: Extinguishing Degree UL 94 V-0
Thermal Protection	Yes
Operating State / Fault Indication	Green Flag / Not Green Flag
Remote Contacts (RC)	Yes
RC Switching Capacity	AC: 250V/1A, 125V/1A; DC: 48V/0.5A, 24V/0.5A, 12V/0.5A
RC Conductor Cross Section (max)	1.5mm ² (Solid) / 16 AWG (Solid)
Single Unit Weight pounds	1.491
Single Unit Weight grams	676

DT2 DIN Rail Surge Protection Class II, 1+0 Mode

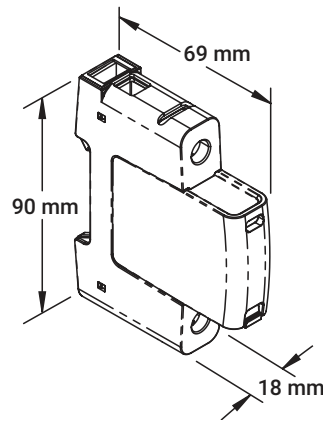

Features

- Compact, yet high surge rated pluggable design, using minimum DIN rail width
- External back-up fuse is not required up to 315 A
- Retaining clip ensures enhanced vibration and shock resistance performance
- Red/Green status indication and change-over contacts standard for remote monitoring

Certification Details: IEC 61643-11 Class I+II
EN 61643-11 Type 1+2
UL 1449, 4th Edition Type 1CA

Complies with: IEC 61643-11:2011
EN 61643-11:2012
UL 1449, 4th Edition
CSA C22.2 No. 269-4

Protection Modes: L-N, N-PE



Part Number	DT27510R	DT215010R	DT230010R	DT248010R
IEC Electrical				
Nominal AC Voltage (50/60Hz) U_o / U_n	60V	120V	240V	400V
Maximum Continuous Operating Voltage (AC) U_c	75V	150V	300V	480V
Nominal Discharge Current (8/20 μ s) I_n	20 kA			
Maximum Discharge Current (8/20 μ s) I_{max}	50 kA			
Voltage Protection Level U_p	800V	1250V	1500V	2300V
Response Time t_a	< 25 ns			
Back-Up Fuse (max)	315A / 250A gG			
Short-Circuit Current Rating (AC) ISCCR	25 kA / 50 kA			
TOV Withstand 5s U_T	114V	229V	337V	581V
TOV 120 min UT/mode	114V/withstand	229V/safe fail	442V/safe fail	762V/safe fail
Number of Ports	1			
UL Electrical				
Maximum Continuous Operating Voltage (AC) MCOV	75V	150V	300V	480V
Voltage Protection Rating VPR	500V	700V	1200V	1500V
Nominal Discharge Current (8/20 μ s) I_n	20 kA			
Short-Circuit Current Rating (AC) SCCR	100 kA	200 kA	150 kA	200 kA
Mechanical				
Operating Temperature Range T_a	-40° F to +158° F [-40° C to +70° C]			
Terminal Screw Torque M_{max}	39.9 lbf-in [4.5 Nm]			
Conductor Cross Section (max)	35mm ² (Solid) / 25mm ² (Stranded) 2 AWG (Solid) / 4 AWG (Stranded)			
Mounting	35 mm DIN Rail, EN 60715			
Housing Material	Thermoplastic: Extinguishing Degree UL 94 V-0			
Thermal Protection	Yes			
Operating State / Fault Indication	Green Flag / Not Green Flag			
Remote Contacts (RC)	Yes			
RC Switching Capacity	AC: 250V/1A, 125V/1A; DC: 48V/0.5A, 24V/0.5A, 12V/0.5A			
RC Conductor Cross Section (max)	1.5mm ² (Solid) / 16 AWG (Solid)			
Single Unit Weight pounds	0.274	0.283	0.298	0.320
Single Unit Weight grams	124	128	135	145

DT2 DIN Rail Surge Protection Class II, 2+0 Mode

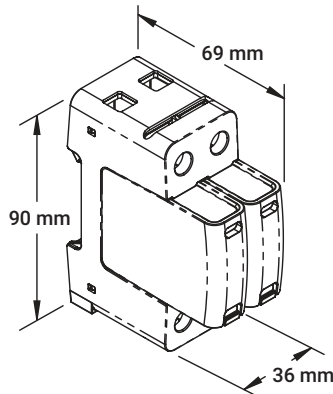

Features

- Compact, yet high surge rated pluggable design, using minimum DIN rail width
- External back-up fuse is not required up to 315 A
- Retaining clip ensures enhanced vibration and shock resistance performance
- Red/Green status indication and change-over contacts standard for remote monitoring

Certification Details: IEC 61643-11 Class II
EN 61643-11 Type 2
UL 1449, 4th Edition Type 1CA

Complies with: IEC 61643-11:2011
EN 61643-11:2012
UL 1449, 4th Edition
CSA C22.2 No. 269-4

Protection Modes: L-PE, N-PE



Part Number	DT230020R
IEC Electrical	
Nominal AC Voltage (50/60Hz) U_o / U_n	240V
Maximum Continuous Operating Voltage (AC) U_c	300V
Nominal Discharge Current (8/20 μ s) I_n	20 kA
Maximum Discharge Current (8/20 μ s) I_{max}	50 kA
Voltage Protection Level U_p	1500V
Response Time t_a	< 25 ns
Back-Up Fuse (max)	315A / 250A gG
Short-Circuit Current Rating (AC) ISCCR	25 kA / 50 kA
TOV Withstand 5s U_T	337V
TOV 120 min U_T /mode	442V/safe fail
Number of Ports	1
UL Electrical	
Maximum Continuous Operating Voltage (AC) MCOV	300V
Voltage Protection Rating VPR	1200V
Nominal Discharge Current (8/20 μ s) I_n	20 kA
Short-Circuit Current Rating (AC) SCCR	150 kA
Mechanical	
Operating Temperature Range T_a	-40° F to +158° F [-40° C to +70° C]
Terminal Screw Torque M_{max}	39.9 lbf-in [4.5 Nm]
Conductor Cross Section (max)	35mm ² (Solid) / 25mm ² (Stranded) 2 AWG (Solid) / 4 AWG (Stranded)
Mounting	35 mm DIN Rail, EN 60715
Housing Material	Thermoplastic: Extinguishing Degree UL 94 V-0
Thermal Protection	Yes
Operating State / Fault Indication	Green Flag / Not Green Flag
Remote Contacts (RC)	Yes
RC Switching Capacity	AC: 250V/1A, 125V/1A; DC: 48V/0.5A, 24V/0.5A, 12V/0.5A
RC Conductor Cross Section (max)	1.5mm ² (Solid) / 16 AWG (Solid)
Single Unit Weight pounds	0.587
Single Unit Weight grams	266

DT2 DIN Rail Surge Protection Class II, 3+0 Mode

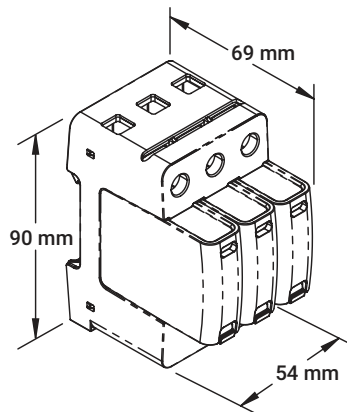

Features

- Compact, yet high surge rated pluggable design, using minimum DIN rail width
- External back-up fuse is not required up to 315 A
- Retaining clip ensures enhanced vibration and shock resistance performance
- Red/Green status indication and change-over contacts standard for remote monitoring

Certification Details: IEC 61643-11 Class II
EN 61643-11 Type 2
UL 1449, 4th Edition Type 1CA

Complies with: IEC 61643-11:2011
EN 61643-11:2012
UL 1449, 4th Edition
CSA C22.2 No. 269-4

Protection Modes: L-PEN



Part Number	DT230030R	DT248030R
IEC Electrical		
Nominal AC Voltage (50/60Hz) U_o / U_n	240V	400V
Maximum Continuous Operating Voltage (AC) U_c	300V	480V
Nominal Discharge Current (8/20 μ s) I_n	20 kA	
Maximum Discharge Current (8/20 μ s) I_{max}	50 kA	
Voltage Protection Level U_p	1500V	2300V
Response Time t_A	< 25 ns	
Back-Up Fuse (max)	315A / 250A gG	
Short-Circuit Current Rating (AC) ISCCR	25 kA / 50 kA	
TOV Withstand 5s U_T	337V	581V
TOV 120 min U_T /mode	442V/safe fail	762V/safe fail
Number of Ports	1	
UL Electrical		
Maximum Continuous Operating Voltage (AC) MCOV	300V	480V
Voltage Protection Rating VPR	1200V	1500V
Nominal Discharge Current (8/20 μ s) I_n	20 kA	
Short-Circuit Current Rating (AC) SCCR	150 kA	200 kA
Mechanical		
Operating Temperature Range T_a	-40° F to +158° F [-40° C to +70° C]	
Terminal Screw Torque M_{max}	39.9 lbf-in [4.5 Nm]	
Conductor Cross Section (max)	35mm ² (Solid) / 25mm ² (Stranded) 2 AWG (Solid) / 4 AWG (Stranded)	
Mounting	35 mm DIN Rail, EN 60715	
Housing Material	Thermoplastic: Extinguishing Degree UL 94 V-0	
Thermal Protection	Yes	
Operating State / Fault Indication	Green Flag / Not Green Flag	
Remote Contacts (RC)	Yes	
RC Switching Capacity	AC: 250V/1A, 125V/1A; DC: 48V/0.5A, 24V/0.5A, 12V/0.5A	
RC Conductor Cross Section (max)	1.5mm ² (Solid) / 16 AWG (Solid)	
Single Unit Weight pounds	0.829	0.896
Single Unit Weight grams	376	406

DT2 DIN Rail Surge Protection Class II, 4+0 Mode

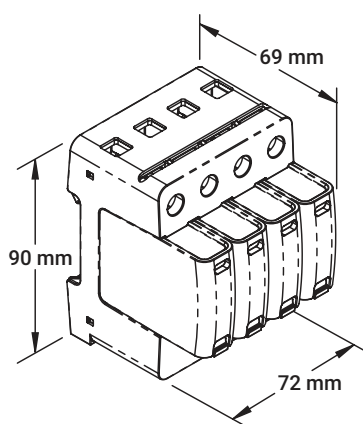

Features

- Compact, yet high surge rated pluggable design, using minimum DIN rail width
- External back-up fuse is not required up to 315 A
- Retaining clip ensures enhanced vibration and shock resistance performance
- Red/Green status indication and change-over contacts standard for remote monitoring

Certification Details: IEC 61643-11 Class I+II
EN 61643-11 Type 1+2
UL 1449, 4th Edition Type 1CA

Complies with: IEC 61643-11:2011
EN 61643-11:2012
UL 1449, 4th Edition
CSA C22.2 No. 269-4

Protection Modes: L-PE, N-PE



Part Number	DT230040R	DT248040R
IEC Electrical		
Nominal AC Voltage (50/60Hz) U_o / U_n	240V	400V
Maximum Continuous Operating Voltage (AC) U_c	300V	480V
Nominal Discharge Current (8/20 μ s) I_n	20 kA	
Maximum Discharge Current (8/20 μ s) I_{max}	50 kA	
Voltage Protection Level Up	1500V	2300V
Response Time t_a	< 25 ns	
Back-Up Fuse (max)	315A / 250A gG	
Short-Circuit Current Rating (AC) ISCCR	25 kA / 50 kA	
TOV Withstand 5s U_T	337V	581V
TOV 120 min U_T /mode	442V/safe fail	762V/safe fail
Number of Ports	1	
UL Electrical		
Maximum Continuous Operating Voltage (AC) MCOV	300V	480V
Voltage Protection Rating VPR	1200V	1500V
Nominal Discharge Current (8/20 μ s) I_n	20 kA	
Short-Circuit Current Rating (AC) SCCR	150 kA	200 kA
Mechanical		
Operating Temperature Range T_a	-40° F to +158° F [-40° C to +70° C]	
Terminal Screw Torque M_{max}	39.9 lbf·in [4.5 Nm]	
Conductor Cross Section (max)	35mm ² (Solid) / 25mm ² (Stranded) 2 AWG (Solid) / 4 AWGa (Stranded)	
Mounting	35 mm DIN Rail, EN 60715	
Housing Material	Thermoplastic: Extinguishing Degree UL 94 V-0	
Thermal Protection	Yes	
Operating State / Fault Indication	Green Flag / Not Green Flag	
Remote Contacts (RC)	Yes	
RC Switching Capacity	AC: 250V/1A, 125V/1A; DC: 48V/0.5A, 24V/0.5A, 12V/0.5A	
RC Conductor Cross Section (max)	1.5mm ² (Solid) / 16 AWG (Solid)	
Single Unit Weight pounds	1.114	1.202
Single Unit Weight grams	505	545

DT2 DIN Rail Surge Protection Class II, 1+1 Mode

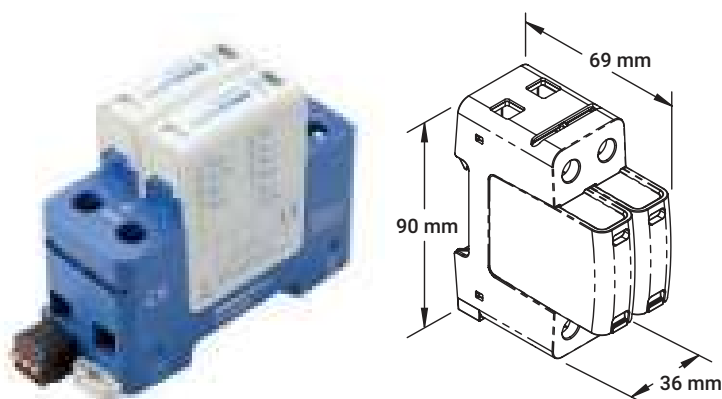

Features

- Compact, yet high surge rated pluggable design, using minimum DIN rail width
- External back-up fuse is not required up to 315 A
- Retaining clip ensures enhanced vibration and shock resistance performance
- Red/Green status indication and change-over contacts standard for remote monitoring

Certification Details:	IEC 61643-11 Class I+II EN 61643-11 Type 1+2 UL 1449, 4th Edition Type 1CA
Complies with:	IEC 61643-11:2011 EN 61643-11:2012 UL 1449, 4th Edition CSA C22.2 No. 269-4
Protection Modes:	L-N, N-PE

Part Number	DT27511R	DT230011R
IEC Electrical		
Nominal AC Voltage (50/60Hz) U_o / U_n	60V	240V
Maximum Continuous Operating Voltage (AC) L-N U_c	75V	300V
Maximum Continuous Operating Voltage (AC) N-PE U_c	305V	305V
Nominal Discharge Current (8/20 μ s) L-N / N-PE I_n	20 kA / 40 kA	
Maximum Discharge Current (8/20 μ s) L-N / N-PE I_{max}	50 kA / 65 kA	
Voltage Protection Level L-N / N-PE U_p	800V / 1500V	1500V / 1500V
Follow Current Interrupt Rating N-PE I_{fi}	100 ARMS	
Response Time L-N / N-PE t_A	< 25 ns / < 100 ns	
Back-Up Fuse (max)	315A / 250A gG	
Short-Circuit Current Rating (AC) ISCCR	25 kA / 50 kA	
TOV Withstand 5s L-N U_T	114V	337V
TOV 120 min L-N U_T /mode	114V/withstand	442V/safe fail
TOV Withstand 200 ms N-PE U_T	1200V	
Number of Ports	1	
UL Electrical		
Maximum Continuous Operating Voltage (AC) L-N / N-PE MCOV	75V / 305V	300V / 305V
Voltage Protection Rating L-N / N-PE VPR	500V / 1000V	1200V / 1000V
Nominal Discharge Current (8/20 μ s) L-N / N-PE I_n	20 kA / 20 kA	
Short-Circuit Current Rating (AC) L-N SCCR	100 kA	150 kA
Mechanical		
Operating Temperature Range T_a	-40° F to +158° F [-40° C to +70° C]	
Terminal Screw Torque M_{max}	39.9 lbf-in [4.5 Nm]	
Conductor Cross Section (max)	35mm ² (Solid) / 25mm ² (Stranded) 2 AWG (Solid) / 4 AWG (Stranded)	
Mounting	35 mm DIN Rail, EN 60715	
Degree of Protection	IP 20	
Housing Material	Thermoplastic: Extinguishing Degree UL 94 V-0	
Thermal Protection	Yes	
Operating State / Fault Indication	Green Flag / Not Green Flag	
Remote Contacts (RC)	Yes	
RC Switching Capacity	AC: 250V/1A, 125V/1A; DC: 48V/0.5A, 24V/0.5A, 12V/0.5A	
RC Conductor Cross Section (max)	1.5mm ² (Solid) / 16 AWG (Solid)	
Single Unit Weight pounds	0.505	0.530
Single Unit Weight grams	229	240

DT2 DIN Rail Surge Protection Class II, 3+1 Mode

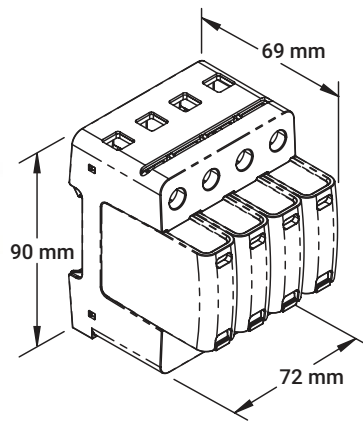

Features

- Compact, yet high surge rated pluggable design, using minimum DIN rail width
- External back-up fuse is not required up to 315 A
- Retaining clip ensures enhanced vibration and shock resistance performance
- Red/Green status indication and change-over contacts standard for remote monitoring

Certification Details: IEC 61643-11 Class II
EN 61643-11 Type 2
UL 1449, 4th Edition Type 1CA

Complies with: IEC 61643-11:2011
EN 61643-11:2012
UL 1449, 4th Edition
CSA C22.2 No. 269-4

Protection Modes: L-N, N-PE



Part Number	DT230031R
IEC Electrical	
Nominal AC Voltage (50/60Hz) U_o / U_n	240V
Maximum Continuous Operating Voltage (AC) L-N U_c	300V
Maximum Continuous Operating Voltage (AC) N-PE U_c	305V
Nominal Discharge Current (8/20 μ s) L-N / N-PE I_n	20 kA / 40 kA
Maximum Discharge Current (8/20 μ s) L-N / N-PE I_{max}	50 kA / 65 kA
Voltage Protection Level L-N / N-PE U_p	1500V / 1500V
Follow Current Interrupt Rating N-PE I_{fi}	100 ARMS
Response Time L-N / N-PE t_A	< 25 ns / < 100 ns
Back-Up Fuse (max)	315A / 250A gG
Short-Circuit Current Rating (AC) ISCCR	25 kA / 50 kA
TOV Withstand 5s L-N U_T	337V
TOV 120 min L-N U_T /mode	442V/safe fail
TOV Withstand 200 ms N-PE U_T	1200V / 300A
Number of Ports	1
UL Electrical	
Maximum Continuous Operating Voltage (AC) L-N / N-PE MCOV	300V / 305V
Voltage Protection Rating L-N / N-PE VPR	1200V / 1000V
Nominal Discharge Current (8/20 μ s) L-N / N-PE I_n	20 kA / 20 kA
Short-Circuit Current Rating (AC) L-N SCCR	150 kA
Mechanical	
Operating Temperature Range T_a	-40° F to +158° F [-40° C to +70° C]
Terminal Screw Torque M_{max}	39.9 lbf-in [4.5 Nm]
Conductor Cross Section (max)	35mm ² (Solid) / 25mm ² (Stranded) 2 AWG (Solid) / 4 AWG (Stranded)
Mounting	35 mm DIN Rail, EN 60715
Housing Material	Thermoplastic: Extinguishing Degree UL 94 V-0
Thermal Protection	Yes
Operating State / Fault Indication	Green Flag / Not Green Flag
Remote Contacts (RC)	Yes
RC Switching Capacity	AC: 250V/1A, 125V/1A; DC: 48V/0.5A, 24V/0.5A, 12V/0.5A
RC Conductor Cross Section (max)	1.5mm ² (Solid) / 16 AWG (Solid)
Single Unit Weight pounds	1.072
Single Unit Weight grams	486

EDT2 Enhanced Din Rail Surge Protection Class II, 1+0 Mode

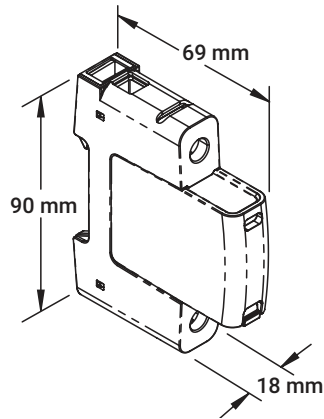

Features

- Compact, yet high surge rated pluggable design, using minimum DIN rail width
- External back-up fuse is not required up to 315 A
- Retaining clip ensures enhanced vibration and shock resistance performance
- Red/Green status indication and change-over contacts standard for remote monitoring

Certification Details:	IEC 61643-11 Class I+II EN 61643-11 Type 1+2 UL 1449, 4th Edition Type 1CA
Complies with:	IEC 61643-11:2011 EN 61643-11:2012 UL 1449, 4th Edition CSA C22.2 No. 269-4
Protection Modes:	L-N, N-PE



Part Number	EDT27510R	EDT215010R	EDT230010R	EDT248010R	EDT255010R	EDT275010R
IEC Electrical						
Nominal AC Voltage (50/60Hz) U_o / U_n	60V	120V	240V	400V	400V	600V
Maximum Continuous Operating Voltage (AC) U_c	75V	150V	300V	480V	550V	750V
Nominal Discharge Current (8/20 μ s) I_n	20 kA					
Maximum Discharge Current (8/20 μ s) I_{max}	50 kA					35 kA
Voltage Protection Level U_p	800V	1250V	1650V	2300V	2500V	3500V
Response Time t_a	< 25 ns					
Back-Up Fuse (max)	315A / 250A gG					
Short-Circuit Current Rating (AC) ISCCR	25 kA / 50 kA					
TOV Withstand 120 min U_T	150V	300V	442V	762V	918V	1200V
Number of Ports	1					
UL Electrical						
Maximum Continuous Operating Voltage (AC) MCOV	75V	150V	300V	480V	550V	750V
Voltage Protection Rating VPR	500V	700V	1200V	1800V	1800V	3000V
Nominal Discharge Current (8/20 μ s) I_n	20 kA					
Short-Circuit Current Rating (AC) SCCR	85 kA	200 kA	150 kA	200 kA	200 kA	200 kA
Mechanical						
Operating Temperature Range T_a	-40° F to +158° F [-40° C to +70° C]					
Terminal Screw Torque M_{max}	39.9 lbf-in [4.5 Nm]					
Conductor Cross Section (max)	35mm ² (Solid) / 25mm ² (Stranded) 2 AWG (Solid) / 4 AWG (Stranded)					
Mounting	35 mm DIN Rail, EN 60715					
Housing Material	Thermoplastic: Extinguishing Degree UL 94 V-0					
Thermal Protection	Yes					
Operating State / Fault Indication	Mechanical flag	Green Flag / Not Green Flag				
Remote Contacts (RC)	Yes					
RC Switching Capacity	AC: 250V/1A, 125V/1A; DC: 48V/0.5A, 24V/0.5A, 12V/0.5A					
RC Conductor Cross Section (max)	1.5mm ² (Solid) / 16 AWG (Solid)					
Single Unit Weight pounds	0.287	0.296	0.307	0.331	0.342	0.364
Single Unit Weight grams	130	134	139	150	155	165

EDT2 Enhanced DIN Rail Surge Protection Class II, 2+0 Mode

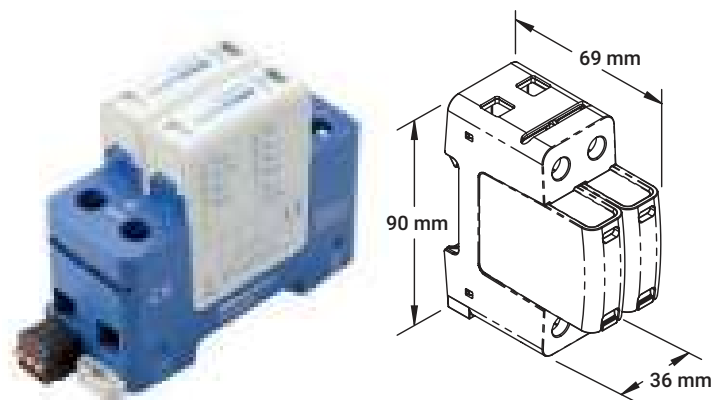

Features

- Includes nVent ERICO TD Technology to ensure reliability throughout adverse voltage conditions
- Enhanced temporary over voltage (TOV) withstand capability
- External back-up fuse is not required up to 315 A
- Compact, yet high surge rated pluggable design, using minimum DIN rail width
- Retaining clip ensures enhanced vibration and shock resistance performance
- Red/Green status indication and change-over contacts standard for remote monitoring

Certification Details:	UL® 1449 Edition 4 Type 1CA
Complies with:	EN 61643-11 Type 2 IEC® 61643-11 Class II
Protection Modes:	L-N, N-PE



Part Number	EDT230020R
IEC Electrical	
Nominal AC Voltage (50/60Hz) U _o / U _n	240V
Maximum Continuous Operating Voltage (AC) U _c	300V
Nominal Discharge Current (8/20 μs) I _n	20 kA 8/20 μs
Maximum Discharge Current (8/20 μs) I _{max}	50 kA 8/20 μs
Voltage Protection Level (Up)	1650V
Response Time t _A	25 ns Max
Back-Up Fuse (max)	250 A @ 50 kA, 315 A @ 25 kA
Short-Circuit Current Rating (AC) ISCCR	25 kA / 50 kA
TOV Withstand 120 min UT	442V Withstand
Number of Ports	1
UL Electrical	
Technology	Thermal Disconnect
Voltage Protection Rating (VPR)	1200V
Nominal Discharge Current (8/20 μs) I _n	20 kA 8/20 μs
Short-Circuit Current Rating (AC) SCCR	150 kA
Mechanical	
Connection, Solid	35 mm ² Max
Connection, Stranded	25 mm ² Max
Torque (TQ)	4.5 N-m
Humidity	5 – 95 % RH
Temperature	-40 to 70 °C
Enclosure Material	UL® 94V-0 Thermoplastic
Enclosure Rating	IP 20
Mounting	35 mm top hat DIN rail
Remote Contact Switching Capacity	1.0 A @ 250 VAC, 1.0 A @ 125 VAC, 0.5 A @ 48 VDC, 0.5 A @ 24 VDC, 0.5 A @ 12 VDC
Remote Contacts	Yes
Status Indication	Mechanical flag
Depth (D)	69 mm
Height (H)	90 mm
Width (W)	36 mm
Unit Weight	0.274 kg

EDT2 Enhanced DIN Rail Surge Protection Class II, 3+0 Mode

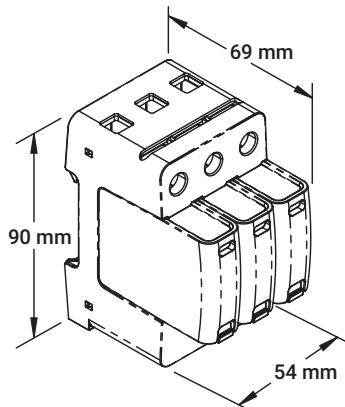

Features

- Compact, yet high surge rated pluggable design, using minimum DIN rail width
- External back-up fuse is not required up to 315 A
- Retaining clip ensures enhanced vibration and shock resistance performance
- Red/Green status indication and change-over contacts standard for remote monitoring

Certification Details:	IEC 61643-11 Class II EN 61643-11 Type 2 UL 1449, 4th Edition Type 1CA
Complies with:	IEC 61643-11:2011 EN 61643-11:2012 UL 1449, 4th Edition CSA C22.2 No. 269-4
Protection Modes:	L-PEN



Part Number	EDT230030R	EDT248030R
IEC Electrical		
Nominal AC Voltage (50/60Hz) U _o / U _n	240V	400V
Maximum Continuous Operating Voltage (AC) U _c	300V	480V
Nominal Discharge Current (8/20 μs) I _n	20 kA	
Maximum Discharge Current (8/20 μs) I _{max}	50 kA	
Voltage Protection Level Up	1650V	2300V
Response Time t _A	< 25 ns	
Back-Up Fuse (max)	315A / 250A gG	
Short-Circuit Current Rating (AC) ISCCR	25 kA / 50 kA	
TOV Withstand 120 min UT	442V	762V
Number of Ports	1	
UL Electrical		
Maximum Continuous Operating Voltage (AC) MCOV	300V	480V
Voltage Protection Rating VPR	1200V	1800V
Nominal Discharge Current (8/20 μs) I _n	20 kA	
Short-Circuit Current Rating (AC) SCCR	150 kA	200 kA
Mechanical		
Operating Temperature Range T _a	-40° F to +158° F [-40° C to +70° C]	
Terminal Screw Torque M _{max}	39.9 lbf-in [4.5 Nm]	
Conductor Cross Section (max)	35mm ² (Solid) / 25mm ² (Stranded) 2 AWG (Solid) / 4 AWG (Stranded)	
Mounting	35 mm DIN Rail, EN 60715	
Housing Material	Thermoplastic: Extinguishing Degree UL 94 V-0	
Thermal Protection	Yes	
Operating State / Fault Indication	Green Flag / Not Green Flag	Mechanical flag
Remote Contacts (RC)	Yes	
RC Switching Capacity	AC: 250V/1A, 125V/1A; DC: 48V/0.5A, 24V/0.5A, 12V/0.5A	
RC Conductor Cross Section (max)	1.5mm ² (Solid) / 16 AWG (Solid)	
Single Unit Weight pounds	0.856	0.928
Single Unit Weight grams	388	421

EDT2 Enhanced DIN Rail Surge Protection Class II, 4+0 Mode

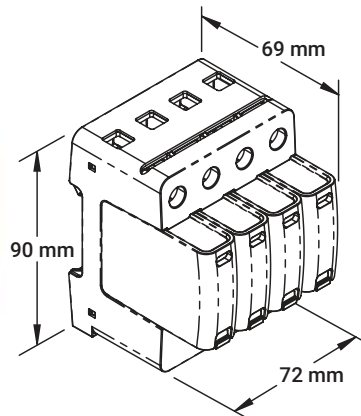

Features

- Compact, yet high surge rated pluggable design, using minimum DIN rail width
- External back-up fuse is not required up to 315 A
- Retaining clip ensures enhanced vibration and shock resistance performance
- Red/Green status indication and change-over contacts standard for remote monitoring

Certification Details:	IEC 61643-11 Class II EN 61643-11 Type 2 UL 1449, 4th Edition Type 1CA
Complies with:	IEC 61643-11:2011 EN 61643-11:2012 UL 1449, 4th Edition CSA C22.2 No. 269-4
Protection Modes:	L-PE, N-PE



Part Number	EDT230040R	EDT248040R
IEC Electrical		
Nominal AC Voltage (50/60Hz) U_o / U_n	240V	400V
Maximum Continuous Operating Voltage (AC) U_c	300V	480V
Nominal Discharge Current (8/20 μ s) I_n	20 kA	
Maximum Discharge Current (8/20 μ s) I_{max}	50 kA	
Voltage Protection Level U_p	1650V	2300V
Response Time t_a	< 25 ns	
Back-Up Fuse (max)	315A / 250A gG	
Short-Circuit Current Rating (AC) ISCCR	25 kA / 50 kA	
TOV Withstand 120 min U_T	442V	762V
Number of Ports	1	
UL Electrical		
Maximum Continuous Operating Voltage (AC) MCOV	300V	480V
Voltage Protection Rating VPR	1200V	1800V
Nominal Discharge Current (8/20 μ s) I_n	20 kA	
Short-Circuit Current Rating (AC) SCCR	150 kA	200 kA
Mechanical		
Operating Temperature Range T_a	-40° F to +158° F [-40° C to +70° C]	
Terminal Screw Torque M_{max}	39.9 lbf-in [4.5 Nm]	
Conductor Cross Section (max)	35mm ² (Solid) / 25mm ² (Stranded) 2 AWG (Solid) / 4 AWG (Stranded)	
Mounting	35 mm DIN Rail, EN 60715	
Housing Material	Thermoplastic: Extinguishing Degree UL 94 V-0	
Thermal Protection	Yes	
Operating State / Fault Indication	Green Flag / Not Green Flag	Mechanical flag
Remote Contacts (RC)	Yes	
RC Switching Capacity	AC: 250V/1A, 125V/1A; DC: 48V/0.5A, 24V/0.5A, 12V/0.5A	
RC Conductor Cross Section (max)	1.5mm ² (Solid) / 16 AWG (Solid)	
Single Unit Weight pounds	1.149	1.246
Single Unit Weight grams	521	565

EDT2 Enhanced DIN Rail Surge Protection Class II, 1+1 Mode

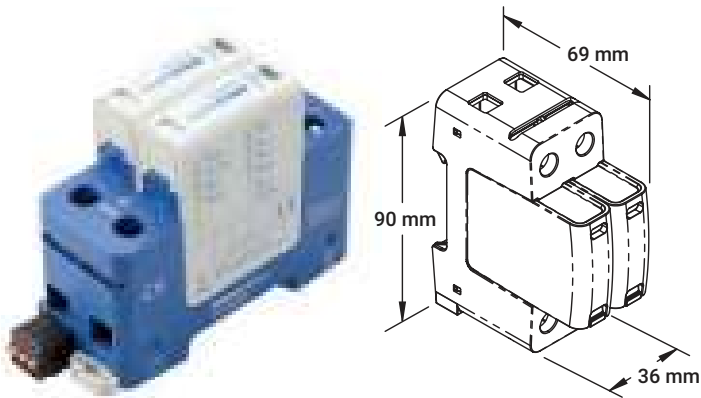

Features

- Compact, yet high surge rated pluggable design, using minimum DIN rail width
- External back-up fuse is not required up to 315 A
- Retaining clip ensures enhanced vibration and shock resistance performance
- Red/Green status indication and change-over contacts standard for remote monitoring

Certification Details:	IEC 61643-11 Class II EN 61643-11 Type 2 UL 1449, 4th Edition Type 1CA
Complies with:	IEC 61643-11:2011 EN 61643-11:2012 UL 1449, 4th Edition CSA C22.2 No. 269-4
Protection Modes:	L-N, N-PE



Part Number	EDT27511R	EDT230011R
IEC Electrical		
Nominal AC Voltage (50/60Hz) U_o / U_n	60V	240V
Maximum Continuous Operating Voltage (AC) L-N U_c	75V	300V
Maximum Continuous Operating Voltage (AC) N-PE U_c	305V	
Nominal Discharge Current (8/20 μ s) L-N / N-PE I_n	20 kA / 40 kA	
Maximum Discharge Current (8/20 μ s) L-N / N-PE I_{max}	50 kA / 65 kA	
Voltage Protection Level L-N / N-PE U_p	800V / 1500V	1650V / 1500V
Follow Current Interrupt Rating N-PE I_{fi}	100 ARMS	
Response Time L-N / N-PE t_A	< 25 ns / < 100 ns	
Back-Up Fuse (max)	315A / 250A gG	
Short-Circuit Current Rating (AC) ISCCR	25 kA / 50 kA	
TOV Withstand 120 min L-N U_T /mode	150V	442V
TOV Withstand 200 ms N-PE U_T	1200V	
Number of Ports	1	
UL Electrical		
Maximum Continuous Operating Voltage (AC) L-N / N-PE MCOV	75V / 305V	300V / 305V
Voltage Protection Rating L-N / N-PE VPR	500V / 1000V	1200V / 1000V
Nominal Discharge Current (8/20 μ s) L-N / N-PE I_n	20 kA / 20 kA	
Short-Circuit Current Rating (AC) L-N SCCR	85 kA	150 kA
Mechanical		
Operating Temperature Range T_a	-40° F to +158° F [-40° C to +70° C]	
Terminal Screw Torque M_{max}	39.9 lbf-in [4.5 Nm]	
Conductor Cross Section (max)	35mm ² (Solid) / 25mm ² (Stranded) 2 AWG (Solid) / 4 AWG (Stranded)	
Mounting	35 mm DIN Rail, EN 60715	
Housing Material	Thermoplastic: Extinguishing Degree UL 94 V-0	
Thermal Protection	Yes	
Operating State / Fault Indication	Mechanical Flag	Green Flag / Not Green Flag
Remote Contacts (RC)	Yes	
RC Switching Capacity	AC: 250V/1A, 125V/1A; DC: 48V/0.5A, 24V/0.5A, 12V/0.5A	
RC Conductor Cross Section (max)	1.5mm ² (Solid) / 16 AWG (Solid)	
Single Unit Weight pounds	0.519	0.538
Single Unit Weight grams	235	244

EDT2 Enhanced DIN Rail Surge Protection Class II, 3+1 Mode

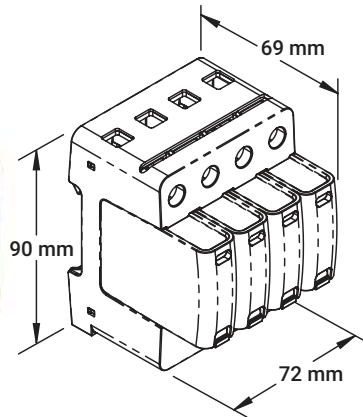

Features

- Compact, yet high surge rated pluggable design, using minimum DIN rail width
- External back-up fuse is not required up to 315 A
- Retaining clip ensures enhanced vibration and shock resistance performance
- Red/Green status indication and change-over contacts standard for remote monitoring

Certification Details:

IEC 61643-11 Class II
EN 61643-11 Type 2
UL 1449, 4th Edition Type 1CA

Complies with:

IEC 61643-11:2011
EN 61643-11:2012
UL 1449, 4th Edition
CSA C22.2 No. 269-4

Protection Modes:

L-N, N-PE



Part Number	EDT230031R
IEC Electrical	
Nominal AC Voltage (50/60Hz) U_o / U_n	240V
Maximum Continuous Operating Voltage (AC) L-N U_c	300V
Maximum Continuous Operating Voltage (AC) N-PE U_c	305V
Nominal Discharge Current (8/20 μ s) L-N / N-PE I_n	20 kA / 40 kA
Maximum Discharge Current (8/20 μ s) L-N / N-PE I_{max}	50 kA / 65 kA
Voltage Protection Level L-N / N-PE U_p	1650V / 1500V
Follow Current Interrupt Rating N-PE I_{fi}	100 ARMS
Response Time L-N / N-PE t_A	< 25 ns / < 100 ns
Back-Up Fuse (max)	315A / 250A gG
Short-Circuit Current Rating (AC) ISCCR	25 kA / 50 kA
TOV Withstand 120 min L-N U_T /mode	442V
TOV Withstand 200 ms N-PE U_T	1200V
Number of Ports	1
UL Electrical	
Maximum Continuous Operating Voltage (AC) L-N / N-PE MCOV	300V / 305V
Voltage Protection Rating L-N / N-PE VPR	1200V / 1000V
Nominal Discharge Current (8/20 μ s) L-N / N-PE I_n	20 kA / 20 kA
Short-Circuit Current Rating (AC) L-N SCCR	150 kA
Mechanical	
Operating Temperature Range T_a	-40° F to +158° F [-40° C to +70° C]
Terminal Screw Torque M_{max}	39.9 lbf-in [4.5 Nm]
Conductor Cross Section (max)	35mm ² (Solid) / 25mm ² (Stranded) 2 AWG (Solid) / 4 AWG (Stranded)
Mounting	35 mm DIN Rail, EN 60715
Housing Material	Thermoplastic: Extinguishing Degree UL 94 V-0
Thermal Protection	Yes
Operating State / Fault Indication	Green Flag / Not Green Flag
Remote Contacts (RC)	Yes
RC Switching Capacity	AC: 250V/1A, 125V/1A; DC: 48V/0.5A, 24V/0.5A, 12V/0.5A
RC Conductor Cross Section (max)	1.5mm ² (Solid) / 16 AWG (Solid)
Single Unit Weight pounds	0.812
Single Unit Weight grams	368

Transient Surge Filter

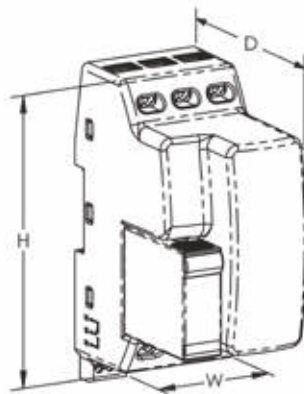

SPECIFICATIONS

Frequency: 0 – 100 Hz
 Max Discharge Current (Imax), L-N: 20 kA 8/20 μ s
 Max Discharge Current (Imax), L-PE: 20 kA 8/20 μ s
 Max Discharge Current (Imax), N-PE: 20 kA 8/20 μ s
 Distribution System: 1Ph 2W+G
 Connection, Solid: 2.5 mm² - 6.0 mm²; #14 - #10
 Connection, Stranded: 2.5 mm² - 6.0 mm²; #14 - #10
 Mounting: 35 mm top hat DIN rail
 Status Indication: Mechanical flag
 Enclosure Material: UL[®] 94V-0 Thermoplastic
 Enclosure Rating: IP 20
 Temperature: -5 to 40 °C
 Module Width: 3 M
 Depth (D): 95 mm
 Height (H): 123 mm
 Width (W): 54 mm
 Unit Weight: 508 grams

FEATURES

- Compact, space saving design
- Replaceable surge module reduces down time and unprotected time during maintenance
- Compliance to the latest UL 1449 Edition 4 and IEC 61643-11 surge standards and UL 1283 Electromagnetic Interference Filters (EMI) standard
- Low let-through voltages on the critical line to neutral mode
- Transient Discriminating (TD) Technology provides increased service life



SPECIFICATION	TSF6A24V	TSF6A120V	TSF20A120V	TSF6A240V	TSF20A240V
Nominal System Voltage (Un)	24 V	120 V		240 V	
Rated Load Current (IL)	6 A		20 A	6 A	20 A
Max Continuous Operating Voltage (Uc)	30 VAC/38 VDC	170 V		275 V	
Stand-off Voltage	–	230		440	
Filtering	-65 dB @ 100 kHz		-50 dB @ 100 kHz	-65 dB @ 100 kHz	-50 dB @ 100 kHz
Replacement Module	TSF24MDS	TSF120MTDS		TSF240MTDS	
Certifications	CE	CE cURus			

Surge Reduction Filter N-Series, Single Phase

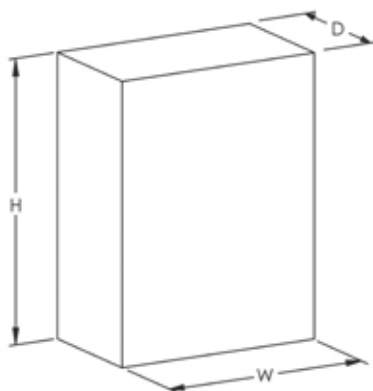

SPECIFICATIONS

Nominal System Voltage (Un): 220 - 240 VAC
 Distribution System: 1Ph 2W+G
 System Compatibility: TN-C, TN-C-S, TN-S, TT
 Frequency: 50 – 60 Hz
 Short Circuit Current Rating (SCCR): 43 kA
 Heat Dissipation: 25 W
 Filtering: -40 dB @ 100 kHz
 Protection Modes: All modes protected
 Technology: Spark Gap, In-line series low pass sine wave filter, TD technology with thermal disconnect (50 kA 8/20us secondary stage)
 Enclosure Material: Metal
 Enclosure Rating: IP 65
 Mounting: Wall mount
 Status Indication: Front panel LED, Internal diagnostic primary and secondary protection LEDs, Change-over contact (Form C dry), 250 VAC/30 VDC/5 A, 4 kV isolation

FEATURES

- High-performance protection incorporating Spark Gap and Transient Discriminating (TD) technologies
- High surge rating ideal for exposed critical service entrance applications
- Reduces let-through voltages and rate-of-voltage rise (dv/dt) and helps provide optimum protection for electronic equipment
- Extreme reliability and simplified design with direct connection from input to output
- Comprehensive front panel status and internal diagnostic LEDs



SPECIFICATION	SRF163N	SRF1125N
Rated Load Current (IL)	63 A	125 A
Rate of Voltage Rise (dv/dt)	3 V/μs Max	8 V/μs Max
Input Connection	10 - 35 mm ²	25 - 120 mm ²
Output Connection	25 - 120 mm ²	
Depth (D)	200 mm	
Height (H)	300 mm	
Width (W)	400 mm	
Unit Weight	10.3 kg	12.3 kg
Complies With	IEC® 61643-11 Class I, Class II ANSI®/IEEE® C62.41.2-2002 Cat A, Cat B, Cat C ANSI®/IEEE® C62.41.2-2002 Scenario II, Exposure 3, 100 kA 8/20 μs, 10 kA 10/350 μs	

Surge Reduction Filter N-Series, Three Phase

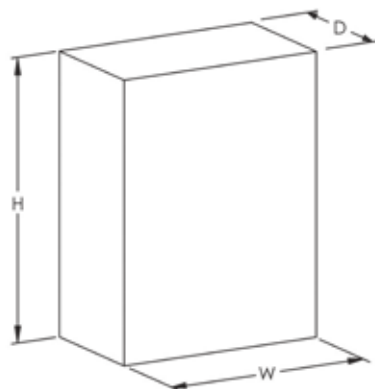

SPECIFICATIONS

Nominal System Voltage (Un): 220/380 - 240/415 VAC

Distribution System: 3Ph Y 4W+G

System Compatibility: TN-C, TN-C-S, TN-S, TT

Frequency: 50 – 60 Hz

Short Circuit Current Rating (SCCR): 43 kA

Filtering: -40 dB @ 100 kHz

Protection Modes: All modes protected

Technology: Spark Gap, In-line series low pass sine wave filter, TD technology with thermal disconnect (50 kA 8/20us secondary stage)

Enclosure Material: Metal

Mounting: Wall mount

Status Indication: Front panel LED, Internal diagnostic primary and secondary protection LEDs, Change-over contact (Form C dry), 250 VAC/30 VDC/5 A, 4 kV isolation

FEATURES

- High-performance protection incorporating Spark Gap and Transient Discriminating (TD) technologies
- High surge rating ideal for exposed critical service entrance applications
- Reduces let-through voltages and rate-of-voltage rise (dv/dt) and helps provide optimum protection for electronic equipment
- Extreme reliability and simplified design with direct connection from input to output
- Comprehensive front panel status and internal diagnostic LEDs



SPECIFICATION	SRF363N	SRF3125N	SRF3250N	SRF3500N	SRF3800N
Rated Load Current (IL)	63 A	125 A	250 A	500 A	800 A
Heat Dissipation	34 W	56 W	98 W	215 W	260 W
Rate of Voltage Rise (dV/dt)	5 V/μs Max	10 V/μs Max	11 V/μs Max	10 V/μs Max	
Input Connection	10 - 35 mm ²	25 - 120 mm ²		10 mm Stud	(2) 10 mm studs
Output Connection	10 - 35 mm ²	25 - 120 mm ²		10 mm Stud	(2) 10 mm studs
Enclosure Rating	IP 65			IP 32	
Depth (D)	200 mm			300 mm	
Height (H)	500 mm		800 mm	1000 mm	1200 mm
Width (W)	400 mm		600 mm	800 mm	
Unit Weight	17.7 kg	21.6 kg	41.7 kg	76.6 kg	97.2 kg
Complies With	IEC® 61643-11 Class I, Class II ANSI®/IEEE® C62.41.2-2002 Cat A, Cat B, Cat C ANSI®/IEEE® C62.41.2-2002 Scenario II, Exposure 3, 100 kA 8/20 μs, 10 kA 10/350 μs				

Coaxial Surge Protector

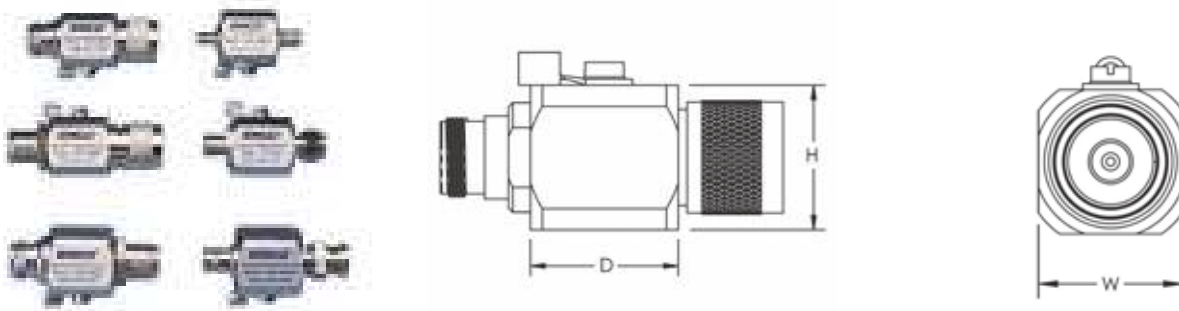

SPECIFICATIONS

Max Discharge Current (Imax), Per Mode: 20 kA 8/20 μ s

Frequency: 0 – 3 GHz

Capacitance: 1.5 pF

Insulation Resistance: 10 G Ω

Impulse Life: 400 @
500 A 10/1000 μ s

Enclosure Material: Metal

Enclosure Rating: IP 20; NEMA[®]-1

Temperature: -40 to 90 °C

FEATURES

- Simple plug-in installation
- Supplied with mounting bracket and flying lead ground
- Low insertion and return loss
- Wide operating frequency spectrum



Part Number	Connection Type	Spark-Over Voltage @ 100 V/ μ s	Spark-Over Voltage @ 100 V/s	Depth D	Height H	Width W	Unit Weight
CSP1NB90	N-Type, Female/Female	450 V	72 – 108 V	25.4 mm	25 mm	25 mm	133.4 g
CSP1NMF90	N-Type, Male/Female	450 V	72 – 108 V	25.4 mm	25 mm	25 mm	133.4 g
CSP1BNC90	BNC, Male/Female	450 V	72 – 108 V	25.4 mm	25 mm	25 mm	133.4 g
CSP1BNC600	BNC, Male/Female	1,100 V	480 – 720 V	25.4 mm	25 mm	25 mm	133.4 g
CSP1SMA90	SMA, Male/Female	450 V	72 – 108 V	25.4 mm	25 mm	25 mm	133.4 g
CSP1NB600	N-Type, Female/Female	1,100 V	480 – 720 V	25.4 mm	25 mm	25 mm	133.4 g

High Speed Data Line Protector

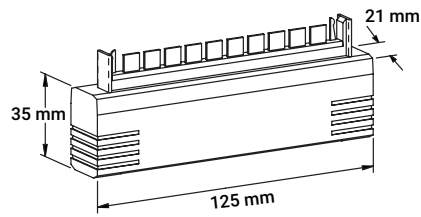

FEATURES

- Multi-stage protection with primary or combination primary/secondary protectors
- 10 pair protector
- Provides both L-L and L-PE protection modes for comprehensive protection Simple installation into Krone® LSA disconnect block
- Data Line Terminator (DLT) available where screw terminal connections are required



SPECIFICATION	HSP10K12	HSP10K36	HSP10K72	HSP10K230
Max Continuous Operating Voltage (Uc)	13 VDC	40 VDC	65 VDC	190 VDC
Max Discharge Current (Imax), L+L-PE	20 kA 8/20 μ s			
Rated Load Current (IL)	150 mA			
Frequency	12 MHz Max			
Transmission Rate	8 Mb/s			
Protection Modes	L-L L-PE			
Technology	Multi-stage			
Connection Type	Krone® LSA-PLUS			
Impedance Balance	55 dB Max			
Insertion Loss	.4 dB Max			
Return Loss	20 dB Max			

Universal Transient Barrier, Single Pair

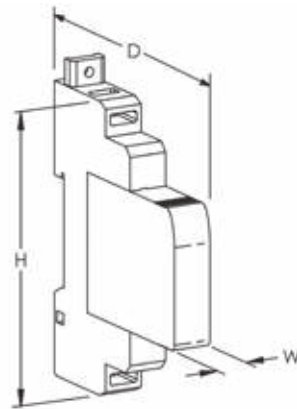

SPECIFICATIONS

Rated Load Current (IL): 2A
 Loop Resistance: 1 Ω
 Max Discharge Current (Imax), L+L-PE: 20 kA 8/20 μs
 Protection Modes: Common, Differential
 Technology: Gas Discharge Tube (GDT), Metal Oxide Varistor (MOV), Silicon Avalanche Diode (SAD)
 Connection, Stranded: 1.0 mm² - 4.0 mm²; #18 - #12
 Mounting: 35 mm top hat DIN rail
 Temperature: -20 to 65 °C
 Enclosure Material: UL® 94V-0 Thermoplastic
 Enclosure Rating: IP 20, NEMA®-1
 Depth (D): 72 mm
 Height (H): 90 mm
 Width (W): 12 mm
 Unit Weight: 68 g
 Certification Details: UL® 497B
 Complies With: ANSI®/IEEE® C62.41.2-2002 Cat A, Cat B, Cat C

FEATURES

- Compact design universal transient barrier provides protection of low-voltage circuits and transducers
- Separate plug and base design allows hot swappable module replacement
- Multi-stage protection and fine over-voltage protection helps ensure lowest residual surge voltages reach sensitive equipment
- Common-mode and differential-mode protection protects against both possible surge conditions
- Surge rating to 20 kA 8/20 μs is ideal for exposed wiring
- Allows for protection of 25 analog signals or 50 digital signals per linear foot (0,3 m) of DIN rail space



SPECIFICATION	UTB5SP	UTB15SP	UTB30SP	UTB60SP	UTB110SP
Nominal System Voltage (Un)	0 - 3 VAC 0 - 5 VDC	3 - 10 VAC 5 - 15 VDC	10 - 21 VAC 15 - 30 VDC	21 - 42 VAC 30 - 60 VDC	100 - 120 VAC 60 - 154 VDC
Max Continuous Operating Voltage (Uc)	5 VAC 7 VDC	12 VAC 18 VDC	23 VAC 33 VDC	45 VAC 64 VDC	150 VAC 170 VDC
Frequency	0.5 MHz	1.0 MHz	2.0 MHz	3.0 MHz	3.0 MHz
Voltage Protection Level (Up), L-L	10 V @ 3 kA	25 V @ 3 kA	44 V @ 3 kA	85 V @ 3 kA	220 V @ 3 kA
Replacement Module	UTB5SPM	UTB15SPM	UTB30SPM	UTB60SPM	UTB110SPM
Certifications	CE NOM UR	CE UR	CE NOM UR	CE UR	CE NOM UR

Universal Transient Barrier, Modem/Telephone

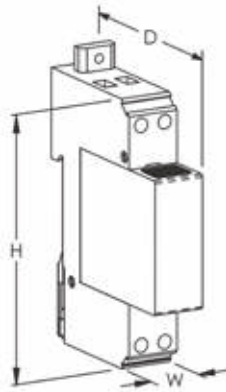

SPECIFICATIONS

Rated Load Current (IL): 160 mA
 Loop Resistance: 1 Ω
 Max Discharge Current (Imax), L+L-PE: 20 kA 8/20 μ s
 Protection Modes: Common, Differential
 Technology: Gas Discharge Tube (GDT), PTC
 Connection, Stranded: 1.0 mm² - 4.0 mm²; #18 - #12
 Mounting: 35 mm top hat DIN rail
 Temperature: -20 to 65 °C
 Enclosure Material: UL[®] 94V-0 Thermoplastic
 Enclosure Rating: IP 20, NEMA[®]-1
 Depth (D): 68 mm
 Height (H): 90 mm
 Width (W): 17.8 mm
 Unit Weight: 99.8 g
 Certification Details: UL[®] 497B
 Complies With: ANSI[®]/IEEE[®] C62.41.2-2002 Cat A, Cat B, Cat C

FEATURES

- General purpose barrier provides protection of low-voltage circuits and transducers
- Separate plug and base design allows hot swappable module replacement
- Multi-stage protection and fine over-voltage protection helps ensure lowest residual surge voltages reach sensitive equipment



SPECIFICATION	UTBSA
Max Continuous Operating Voltage (Uc)	5 VAC 7 VDC
Frequency	15 MHz
Voltage Protection Level (Up), L-L	340 V @ 3 kA
Replacement Module	UTBSM
Certifications	CE NOM

Closed Circuit Television Protector

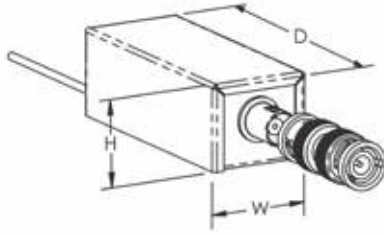

FEATURES

- Robust high energy protection
- Compact package for limited space requirements
- Isolated ground prevents introduction of unwanted noise

SPECIFICATION	CCTV12
Nominal System Voltage (Un)	+/- 12 VDC
Max Continuous Operating Voltage (Uc)	+/- 14 VDC
Voltage Protection Level (Up)	60 V @ 5 kA
Nominal Discharge Current (In)	10 kA 8/20 μ s
Frequency	100 MHz Max
Transmission Rate	16 Mb/s
Impedance	50 – 75 Ω
Connection Type	BNC, Female
Mounting	In-line insertion
Temperature	-25 to 70 °C
Enclosure Material	Metal
Enclosure Rating	IP 20 NEMA®-1
Depth (D)	27.9 mm
Height (H)	90 mm
Width (W)	22.1 mm
Unit Weight	60 g
Standard Packaging Quantity	1 pc
UPC	78285647021
EAN-13	8711893014204

Subscriber Line Protector, Single Stage

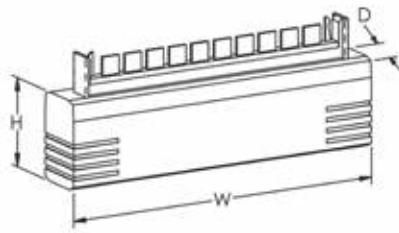

FEATURES

- Single stage protection with primary or combination primary/secondary protectors
- 10 pair protector
- Simple installation into Krone® LSA disconnect block
- Data Line Terminator (DLT) available where screw terminal connections are required



SPECIFICATION	SLP10K1F
Max Continuous Operating Voltage (Uc)	190 VDC
Max Discharge Current (Imax), L+L-PE	20 kA 8/20 μs
Rated Load Current (IL)	1,000 mA
Frequency	12 Hz Max
Transmission Rate	8 Mb/s
Protection Modes	L-L
Technology	Single-stage
Connection Type	Krone® LSA-PLUS
Impedance Balance	48 dB Max
Insertion Loss	.75 dB Max
Return Loss	22 dB Max
Loop Resistance	0.2 Ω
Temperature	-20 to 60 °C
Enclosure Material	UL® 94V-0 Thermoplastic
Depth (D)	21 mm
Height (H)	34.5 mm
Width (W)	125 mm
Unit Weight	22.7 g
Certification Details	UL 497
Certifications	RCM, CE, cULus
Standard Packaging Quantity	1 pc
UPC	78285647508
EAN-13	9321098000460

Telephone Line Protector

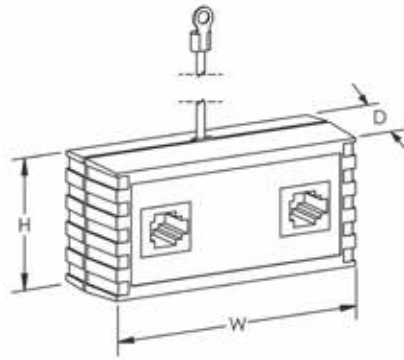

FEATURES

- RJ11 sockets provide simple plug-in connection for 4 or 6 position RJ plugs
- Includes patch cord and adhesive mounting strips
- Provides both L-L and L-PE protection modes for comprehensive protection
- Automatic over-current protection



SPECIFICATION	SLP1RJ11A
Max Continuous Operating Voltage (Uc)	280 V
Max Discharge Current (Imax), Per Mode	20 kA 8/20 μs
Voltage Protection Level (Up), T-R	110 V
Voltage Protection Level (Up), T/R-G	500 V @ 125 A
Rated Load Current (IL)	120 mA
Connection Type	RJ11
Ground Lead Length	152 mm
Lead Size	1.0 mm ² ; #18
Temperature	-40 to 65 °C
Depth (D)	27.9 mm
Height (H)	38.1 mm
Width (W)	77.7 mm
Unit Weight	49.9 g
Enclosure Material	UL® 94V-0 Thermoplastic
Certifications	RCM, NOM, UL

Lan Surge Protector

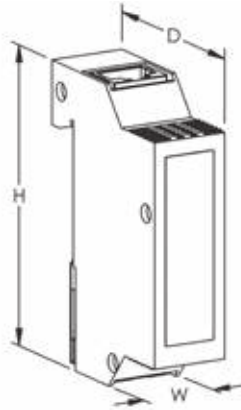

FEATURES

- Rugged, metallic enclosure provides both environmental and electrical shielding
- Up to CAT6 and POE (Power Over Ethernet) protection in one product
- Simple, bi-directional installation

SPECIFICATION	LANRJ45C6P
Nominal System Voltage (Un)	48 VDC
Max Continuous Operating Voltage (Uc)	50 VDC
Voltage Protection Rating (VPR), L-L	150 V
Voltage Protection Rating (VPR), L-PE	550 V
Nominal Discharge Current (In), L-L	150 A 8/20 μ s
Max Discharge Current (Imax), L-PE	10 kA 8/20 μ s
Impulse Current (Iimp)	1 kA 10/350 μ s
Rated Load Current (IL)	1 A
Frequency	250 MHz Max
Temperature	-40 to 80 °C
Connection Type	RJ45
Enclosure Material	Metal
Enclosure Rating	IP 20
Depth (D)	45.5 mm
Height (H)	75 mm
Width (W)	19 mm
Complies With	IEC® 61643-21
Standard Packaging Quantity	1 pc
UPC	78285693008
EAN-13	0782856930082

Glossary of Terminology

8/20MS CURRENT WAVESHAVE

A current impulse with a virtual front time of $8\mu\text{s}$ and a time to half-value of $20\mu\text{s}$.

AGGREGATE SURGE RATING

The sum of the surge ratings of individual voltage limiting components, connected in parallel, in the device.

Note: This figure does not indicate the maximum discharge current (I_{max}) of the device. It does however provide an indication of the expected SPD life. Users should be aware that certain manufacturers may incorrectly claim the aggregate surge rating of MOV material used in their device as its I_{max} . Non-perfect current sharing between parallel MOVs, and the inability of series over-current or thermal disconnects to carry the full surge current, generally means that the maximum discharge current which the SPD can withstand is less than its aggregate surge rating.

ATTENUATION

The ability of an SPD to reduce electrical noise interference, measured in decibels. Attenuation varies with frequency, so it is usual to specify the attenuation of the SPD at a particular frequency; commonly 100kHz.

BACKUP OVERCURRENT PROTECTION

An external overcurrent protective device installed prior to the SPD. Such a device may be required if the overcurrent limiting device on the service is larger than that required by the SPD or connecting wiring.

Class I test

SPD tested with maximum impulse current (I_{imp}) and nominal discharge current (I_n).

Class II test

SPD tested with maximum discharge current (I_{max}) and nominal discharge current (I_n).

Class III test

SPD tested with combination wave.

DISTRIBUTION SYSTEM

Defines the electrical power distribution system. The distribution system is usually described by configuration of the phases, neutral and ground conductor configuration on the secondary side of the supply transformer. Refer to pages 10-12 for further information.

FOLLOW CURRENT (I_f)

The current supplied by the electrical power distribution system which flows through the SPD after a discharge current impulse. The follow current is significantly higher than the operating current, and is normally high for voltage switching type SPDs (e.g. spark gaps) since the arc voltage falls below the AC supply voltage after firing.

IMPULSE CURRENT (I_{imp})

Peak impulse current withstand with a 10/350 μs current waveshape. This is often used for the classification of SPDs tested to Test Class I, but is not the only acceptable waveshape.

INSERTION LOSS

The insertion loss of an SPD is usually only stated for two port devices for use on low voltage data systems. It is a measure of the ratio of voltage at the output to the input at the device under test. The insertion loss is usually stated for a given frequency and measured in decibels.

LEAKAGE CURRENT

The current flowing to the ground conductor when the SPD is connected to the nominal supply voltage U_n .

LET-THROUGH VOLTAGE

Another term often used to describe the measured limiting voltage.

Note: This measurement may be carried out with, or without, the presence of the nominal AC power (U_n) being applied to the SPD. As such, the results may be different and the user should take cognizance of this in making any comparative assessments.

LOCATION CATEGORIES

Various standards attempt to define the electrical environment at which an SPD may be installed, into location categories or zones.

Note: The user should be aware that international consensus has not been reached on these classifications, nor on the size of expected surge activity, which may occur. Further, the user should note that the demarcation of these zones do not form literal boundaries, but are rather a gradual transition.

MAXIMUM CONTINUOUS OPERATING VOLTAGE (U_c)

The maximum r.m.s. or d.c. voltage which may be continuously applied to the SPD's mode of protection without degradation or inhibiting its correct operation.

Note: Specifications given in the catalog generally are phase (L-N) voltages.

MAXIMUM DISCHARGE CURRENT (I_{max})

The maximum single shot current, having an 8/20 μs waveshape, which the SPD can safely divert.

MEASURED LIMITING VOLTAGE

The maximum voltage measured across the SPD's terminals during the application of an impulse of specified waveshape and amplitude.

MODES OF PROTECTION

SPDs may provide protection line-to-ground, line-to-neutral, neutral-to-ground or in combinations thereof. These paths are referred to as the modes of protection.

Note: The user is advised that not all modes require protection, and more is not necessarily better when selecting an SPD. As an example, the N-G mode is not required when the SPD is installed at the primary service entrance of a TN-C-S electrical distribution system, due to the Neutral-Ground bond at this point. The L-L mode is generally not provided for systems with neutral conductors since the L-N modes also protect the L-L modes. Similarly, the L-G mode can be protected via the L-N and N-G modes.

NOMINAL DISCHARGE CURRENT (I_n)

The peak value of the current flowing through the SPD during the application an 8/20 μs waveshape.

Note: IEC 61643-1 requires SPDs tested to Test Class II, to withstand 15 impulses at I_n followed by 0.1, 0.25, 0.5, 0.75 and 1.0 times I_{max} .

NOMINAL (SYSTEM) VOLTAGE (U_n)

The L-N voltage by which an electrical power system is designated. Under normal system conditions, the voltage at the supply terminals may differ from the nominal voltage as determined by the tolerance of the supply system (normally +/- 10%).

ONE-PORT SPD

An SPD connected in shunt (parallel) with the circuit to be protected. A one port device may have separate input and output terminals, but without a specific series impedance between these terminals. This type of connection is also known as a Kelvin connection.

Glossary of Terminology

OPERATING CURRENT

The current drawn (per phase) by the SPD when energized at the nominal operating voltage U_n .

Note: For SPDs with integral series filtering, the total current drawn may be greater than the real rms current consumption (i.e. VA may be greater than Watts). This is due to the presence of the internal filtering capacitance.

OVER-CURRENT PROTECTION

An over-current device, such as a fuse or circuit-breaker, which could be part of the electrical distribution system located externally and upstream of the SPD. May provide protection to the SPD, the connecting wiring and provide a means of externally isolating the SPD.

PROTECTIVE EARTH (PE)

The IEC® 60364 series characterizes low-voltage distribution systems by their grounding methods and the configuration of the neutral and protective conductors. The Protective Earth is commonly referred to as "ground", or "earth", in many regions.

RATED LOAD CURRENT (I_L)

Maximum continuous rated current that can be supplied to a load connected to the protected output of an SPD. Normally only stated for two port, series connected, SPDs.

RESIDUAL VOLTAGE

In IEC terminology this refers to the peak value of the voltage that appears between the terminals of an SPD due to the passage of discharge current I_n . NZS/AS 1768 refers to this as the let-through voltage, a measurement obtained when the stated test impulse is superimposed on top of the nominal system voltage U_n .

SECONDARY SURGE ARRESTER

A loosely used term given to SPDs intended for operation on medium voltage systems (>1kV). Within the USA, a secondary surge arrester defines an SPD Listed by Underwriters Laboratories Inc. for use on LV and MV systems at locations prior to the main overcurrent disconnect to the facility.

Note: Secondary Surge Arrester Listing is generally considered to have less demanding safety requirements than those for UL® 1449 Transient Voltage Surge Arrester Listing.

SHORT CIRCUIT CURRENT RATING (SCCR)

The short-circuit current rating of the SPD. Required by USA National Electric Code (NEC®) for TVSS devices.

SPD DISCONNECTOR

An IEC term used to describe a device (internal and/or external) for disconnecting an SPD from the electrical power system.

Note: This disconnecting device is not required to have isolating capability. It is to prevent a persistent fault on the system and is used to give an indication of the SPD failure. There may be more than one disconnecter function, for example an over-current protection function and a thermal protection function. These functions may be integrated into one unit or performed in separate units.

SPARK-OVER VOLTAGE

The voltage at which a switching type SPD (generally of the spark gap type) will initiate conduction. This value is normally specified for a voltage increasing at 1kV/s.

STATUS INDICATOR

A device(s) that indicates the operational status of the SPD, or of a particular mode of its protection.

Note: Such indicators may be local with visual and/or audible alarms and/or may have remote signaling and/or output contact capability.

SUPPRESSED VOLTAGE RATING (SVR)

A special case of the measured limiting voltage specific to the UL 1449 Listing of an SPD.

Note: This test is performed using a small 500A 8/20µs current limited impulse, and the clamping voltage recorded at the ends of 6" connecting leads. The result obtained is rounded up to the nearest value given in a table.

SURGE PROTECTION DEVICE (SPD)

An IEC term used to describe a device intended to limit transient over-voltages and divert surge currents. It contains at least one non-linear component.

SURGE (REDUCTION) FILTER

A two-port series filtering type of SPD specifically designed to reduce the rate-of-rise of voltage (dv/dt) of the pre-clamped waveform. Such a device normally contains a filter with low-pass performance.

TRANSIENT VOLTAGE SURGE SUPPRESSOR (TVSS)

An SPD tested to meet the safety requirements of UL 1449 - Standard for Transient Voltage Surge Suppressors. UL 1449 defines the basic safety requirements for TVSS devices installed on electrical circuits up to 600V. The United States National Electric Code (NEC) only permits TVSS devices to be installed after (downstream of) the main over-current disconnect to a facility.

TWO-PORT SPD

An SPD with two sets of terminals, input and output (line and equipment), and with a specific impedance inserted between these terminals. These are often referred to as series (in-line) connected SPDs and generally contain wave-shaping filters in addition to simple shunt-only protection.

VOLTAGE PROTECTION LEVEL (U_p)

Similar to the measured limiting voltage, the voltage protection level characterizes the performance of an SPD in limiting the voltage across its terminals.

Note: The voltage protection level is the measured limiting voltage recorded under a specified current magnitude and waveshape, and rounded up to the next highest voltage selected from a list of preferred values found in IEC 61643-1 Standard for surge protective devices connected to low-voltage power distribution systems. For SPDs tested to Test Class I, U_p is generally stated using a 10/350 I_{imp} and for SPDs tested to Test Class II, using an 8/20µs I_{max} .

VOLTAGE PROTECTION RATING (VPR)

A rating selected from a list of preferred values as given in Table 63.1 of ANSI®/UL 1449 and assigned to each mode of protection. The value of the VPR is determined as the nearest highest value taken from Table 63.1 to the measured limiting voltage determined during the transient-voltage surge suppression test using the combination wave generator at a setting of 6 kV, 3 kA.

Our powerful portfolio of brands:

CADDY ERICO HOFFMAN RAYCHEM SCHROFF TRACER



[nVent.com/ERICO](https://www.nvent.com/ERICO)

©2018 nVent. All nVent marks and logos are owned or licensed by nVent Services GmbH or its affiliates. All other trademarks are the property of their respective owners. nVent reserves the right to change specifications without notice.

ERICO-CAT-E1330C-UKEN-P15501SURGEPROTECTIONSOLUTIONS-EN-1807