

# AGM VRLA EP Series



**EXIDE**

INDUSTRIAL  
SOLUTION  
**POWER**



- + Headquartered in **Kolkata**, India
- + Products : **Lead Acid Storage Batteries** : 2.5Ah to 20,000 Ah  
**Home UPS**  
**DC Power Solution**  
**Standby Products & Solutions**
- + **9 Manufacturing units** in India
- + **1 R&D Center** in India
- + **5 Wholly owned Subsidiaries** in India
- + Turnover of **USD 1.3 Billion**
- + An Integrated Manufacturing Unit for **Standby Systems and DC Power solutions** in Kolkata, India.

# WHY EXIDE ( INDIA)



## FEATURES



**Sealed Maintenance Free** : No need for checking Electrolyte level and topping throughout its life. Sealed Construction ensures no leakage or seepage of electrolyte from terminal or casing.



**Free From Orientation Constraints** : The sealed construction with immobilised electrolyte allows the battery to be installed in any position, horizontal vertical sideways – without any effect on its performance.



**Eco Friendly** : The unique gas recombination technology effectively nullifies generation of gas during normal use, It is totally eco – friendly, ensuring clean and safe environment.



**Minimal Voltage Drop** : Since battery emits no gasses or fumes .It can be placed adjacent to the UPS system or other electronic equipment , ensuring minimal voltage drop between battery and equipment.



**Easy Handling –Easy Installation** : Lightweight and compact and commission.



**Ready To Use** : Available in fully (factory ) charged condition.



**Good Service Life** : Between 3 to 5 Years life for small and medium monoblock range (EP RANGE ) depending on cyclic / float applications.



**Low self Discharge** : Self discharge very low as compared to conventional flooded batteries.



**Charge Retention & Recovery** : Excellent charge retention and recovery ability due to special design of plates and separations with an absolutely balanced electrolyte



**Superior High Rate Discharge** : Very Low internal resistance and very high electrolyte – active material reactive interface – allows very high currents for short and medium duration.



**High Reliability** : Tough construction and heavy duty design with superior corrosion resistant lead calcium In alloy.



## BENEFITS

- **Saving of hundred of distilled demineralised water** throughout its lifetime as compared to conventional batteries
- **Saving of manpower** for regular topping up and cleaning corroded terminals as in conventional batteries.
- **No damage of Flooring** by spillage of battery acid or water during maintenance .
- **No need of separate battery room.** Can be installed by stacking together in any convenient orientation or position ,thereby saving huge floor space as compared to conventional batteries.  
Saving of Hundred square feet of costly floor space in metropolitan areas.
- Battery can be installed inside offices and working areas – no need for separate battery rooms , costly acid proof flooring etc. **Battery can be installed in a cabinet also.**
- **No need for elaborate air exhaust systems** as in conventional battery installation.
- **Saving from transmission loss** – Higher efficiency – Lower electricity consumption - Lower cost cabling

- **Does not require specially trained technical manpower** for elaborate installation and commissioning procedures.
- No delay between receipt and use .**Instant power source.**
- **Compatible with the best international makes** in the same capacity range.
- **Can be stored for 3 to 6 Months** , depending upon ambient temperature before recharge and without any loss of efficiency or performance .
- **Lower consumption** of electricity during use.
- **Very long shelf life**
- Leads to **greatly improved ability** to recover from deep discharge
- **Required smaller capacity** (as compared to flooded batteries) for high rate discharges up to 15mins/30mins/60mins duration
- **Lower size, lower space** requirement.
- **Can deliver the rated performance** throughout its service life.



## ADVANTAGE



**Technology** : Manufactured in technical collaboration with Shin-Kobe Electric Machinery Co. Japan, maker of world-renowned Hitachi batteries, Exide (India) Industries Ltd. is an ISO 9001 Organisation.



**Experience** : Over 60 years accumulated Experience of Research & Development, field operation & feedback.



**Manufacturing Base** : The only company having multilocational manufacturing units spread across the country with ultra large manufacturing capacities.



**Result** : Factory fresh batteries, whenever and whenever you need them. VRLA batteries come in factory charged condition and thus, the fresher they are, the better.



**Eco - friendly Company** : ISO 14001, TS 16949, OHSAS 18001 certifications. Ensuring eco-friendly production process. The only company having own smelting house and large network to collect and recycle used batteries to avoid environmental damage.



**Recycle Symbol** : The batteries manufactured both for domestic and export are labelled with the recycle symbol.



**Safety Conscious** : Underwriters Laboratories Inc., USA certification for the products are available as an option.



## APPLICATIONS

### FOR STANDBY POWER



UPS System



Telecommunication System



Office Automation System



Fire Alarm & Security System



Electronic PABX System



Power Plants & substations



Railway Signalling



Electronic Attendance & cash Register



Cable Television Equipment



Geophysical Equipment



PCO Monitors (Electronic)



Process Instrumentation & Control



Cellular Phone & pagers (Base Stations & Transmitters)

### FOR PORTABLE POWER



Search Light



Portable communication Sets



Portable Testing & Measuring Instrument



Solar Lanterns



Medical Electronics



Marine & Offshore Equipment



Vending Machine & Weighing Scales

## General Application

Type of battery	Nominal voltage (V)	Rated capacity (Ah) at 27°C						Dimension				Weight ±5% (KG)	Energy Density (Wh/l)	Specific Energy (Wh/kg) Charged Condition	Internal Resistance (mili-ohm) Max at fully (5 secs)	Maximum Discharge current (Amps.)	Container / Lid Material	Layout	Terminal
		20hrs 1.75V/Cell	10hrs 1.75V/Cell	3hrs 1.7V/Cell	1.5hrs 1.7V/Cell	1hrs 1.6V/Cell	30Mins. 1.6V/Cell	Overall Height(±2)	Height upto lid Top (±2)	Length (±1)	Width (±1)								
EP 7.5-12	12	7.5	6.9	5.5	5.3	4.5	3.7	100.0	94.0	151.0	65.0	2.40	92.00	37.50	22.00	105.00	ABS	b	F2
EP 9-12	12	9	8.1	6.8	6.4	5.4	4.5	100.0	94.0	151.0	65.0	2.60	110.00	42.00	18.00	135.00	ABS	b	F2
EP 12-12	12	12	11.2	9.0	8.6	7.2	6.0	100.0	94.0	151.0	98.0	3.8	98.0	38.0	16.0	180.0	ABS	c	F2
EP 17-12	12	17	16.0	12.9	12.2	10.2	8.5	167.0	167.0	181.0	76.0	5.0	88.0	41.0	15.0	255.0	ABS	d2	F3
EP 26-12 (TP)	12	26	24.0	19.5	18.7	15.6	13.0	175.0	175.0	166.0	125.0	8.8	86.0	35.0	10.0	390.0	TP10	d	F4
EP 26-12 (ABS)	12	26	24.0	19.5	18.7	15.6	13.0	179.0	179.0	178.0	124.0	9.2	79.0	34.0	10.0	390.0	ABS	e	F5
EP 32-12	12	32	29.1	24.0	23.0	19.2	16.0	179.0	179.0	178.0	124.0	9.9	97.0	39.0	10.0	480.0	ABS	e	F5
EP 42-12	12	42	38.5	31.5	30.2	25.2	21.0	181.0	181.0	199.0	165.0	13.9	85.0	36.3	8.0	420.0	TP10	f	F6
EP 65-12	12	65	60.0	48.6	46.8	39.0	32.5	181.0	181.0	350.0	166.0	20.2	75.0	38.6	6.0	500.0	TP10	h	F7
EP 75-12	12	75	69.0	56.2	54.0	45.0	37.5	174.0	174.0	391.0	166.0	23.0	80.0	39.0	6.0	500.0	TP10	h	F7
EP 84-12	12	100	91.0	75.0	72.0	60.0	50.0	235.0	235.0	407.0	173.0	32.5	72.0	36.0	6.0	600.0	TP10	h	F8
EP 100-12	12	100	91.0	75.0	72.0	60.0	50.0	235.0	235.0	407.0	173.0	32.5	73.0	37.0	6.0	600.0	TP10	h	F8
EP 120-12	12	120	109.0	90.0	86.4	72.0	60.0	239.0	239.0	452.0	172.0	38.0	77.0	38.0	6.0	600.0	TP10	i	F9
EP 150-12	12	150	136.5	112.5	108.0	90.0	75.0	240.0	240.0	557.0	172.0	48.30	78.00	38.00	5.00	900.00	TP10	i	F9
EP 200-12	12	200	182.0	150.0	144.0	120.0	100.0	240.0	240.0	533.0	250.0	67.20	75.00	36.00	5.00	1200.00	TP10	j	F9

Table 1

EP RANGE

Advantage : International size - Matches dimension of any International equipment.  
High Rate performance - matches or betters High Rate performance of equivalent international types.



LAYOUT FOR BATTERY OUTLINE

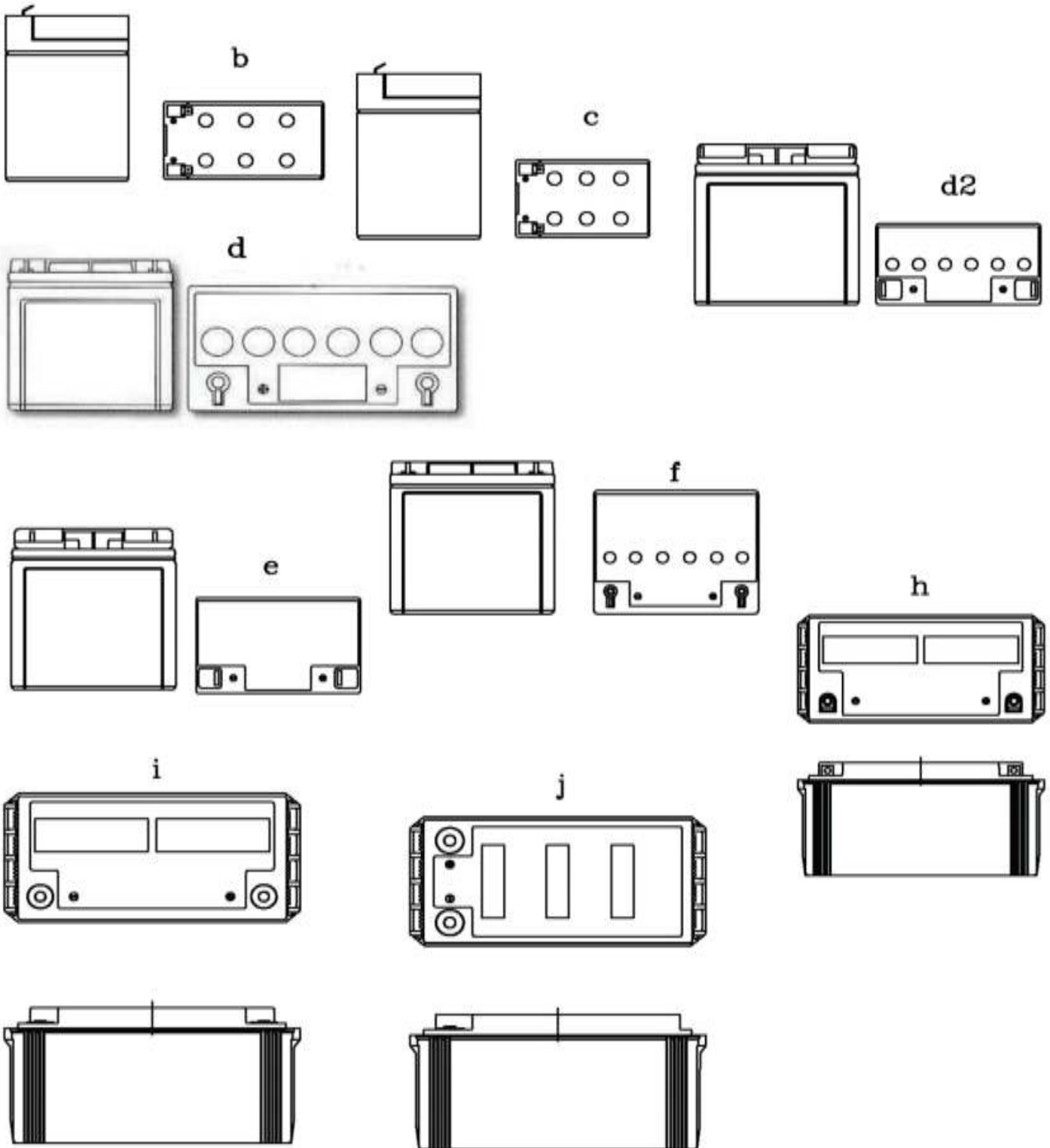



LAYOUT FOR TERMINAL.

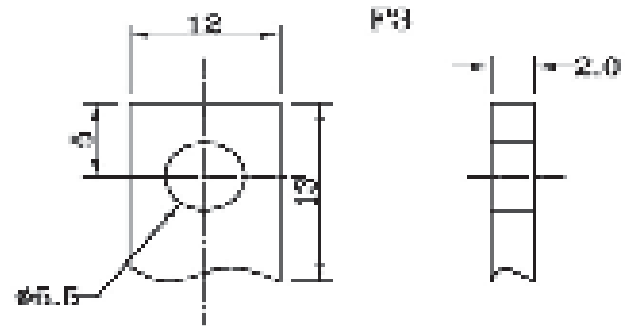
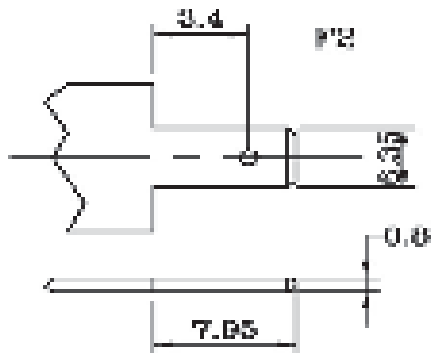

[M5 BOLT & NUT]

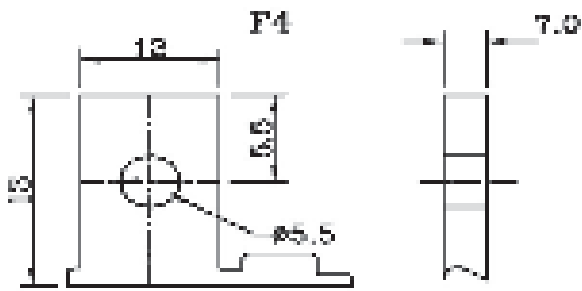

[M5 BOLT & NUT]

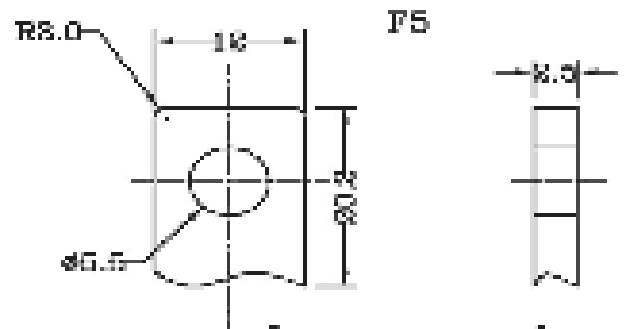

[M5 BOLT & NUT]

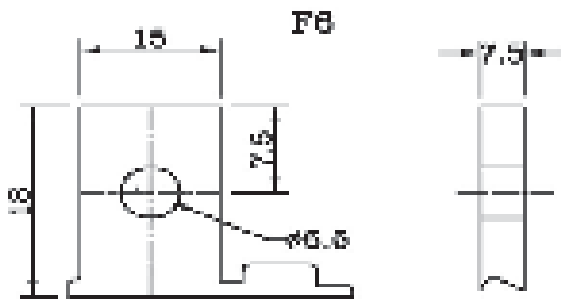

[M5 BOLT & NUT]

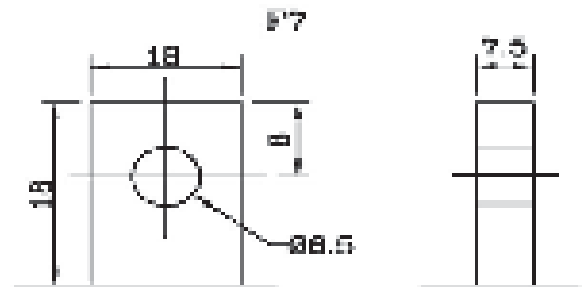

[M5 BOLT & NUT]

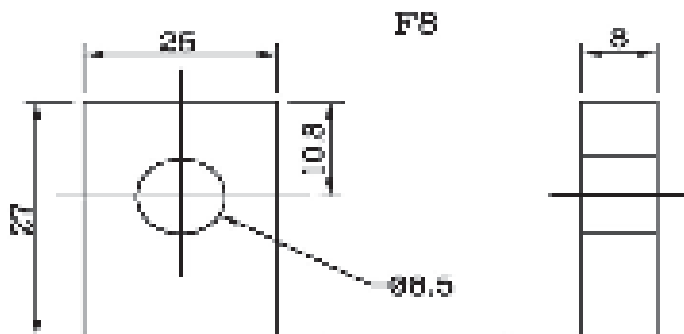

[M8 BOLT & NUT]

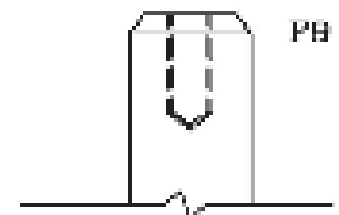

[M8 BOLT]



## BATTERY CHARGING FOR EP SERIES



### CHARGER

'Constant Potential' charges with current limit facility only, are recommended for normal continuous operation.



### CHARGE LIMITS

Table (2) shows the charge voltage and limit current . The charge voltage of the battery has to be reduced with increasing temperature and increased with decreasing temperature. Accordingly, charging with a given voltage requires increased charge current when the temperature is high and reduced charge current at a lower temperature.

- a) Even under high temperature, a charging voltage of 2.2V/cell is required.
- b) Even under low temperature, the charging voltage must be set at less than 245V/cell so as to prevent gas generation from the battery.
- c) The battery life will be shortened as service temperature rises.



### CHARGE PARAMETERS

Recharge Voltages : Batteries to be recharged in CC-CV mode only.

Mode Of Operation	Voltage setting per 12 V unit for ambient temperature 20 -30°C	Current Setting
Float	13.7V +/- 0.1V	Maximum : 0.3CA Minimum : 0.1CA
Cyclic	14.7V +/- 0.1V	
Temperature Compensation : (Reference 25°C) Float : -18mV/°C /12V Unit Cyclic : -30mV/°C/12V Unit		

Table(2)





# CHARGE CHARACTERISTICS

Charge under constant potential charging mode at 27°C

## CYCLIC USE

Recharge at 2.45 V/Cell

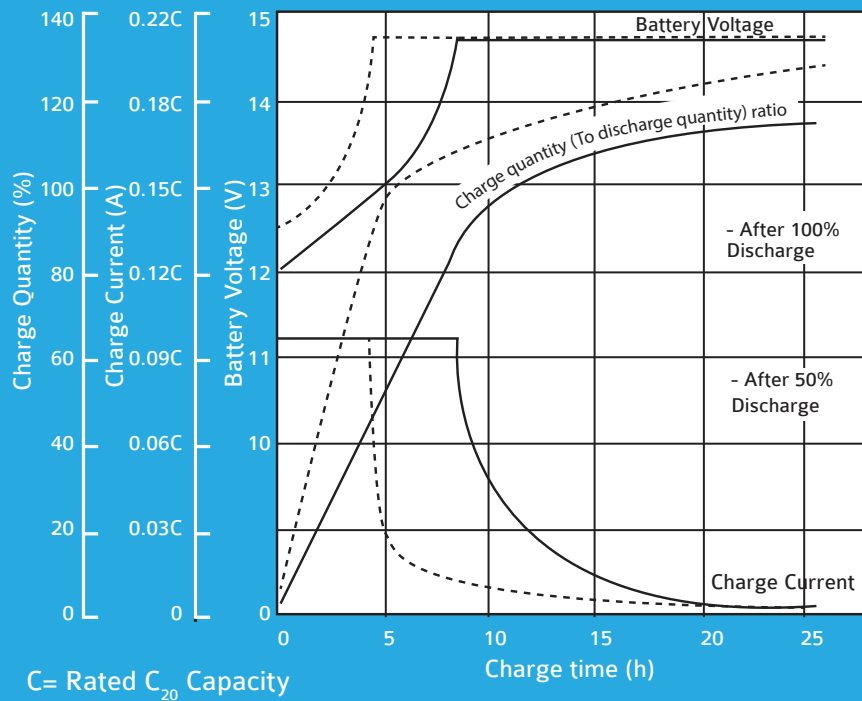

Figure (3)

## STAND BY USE

Recharge at 2.275 V/cell

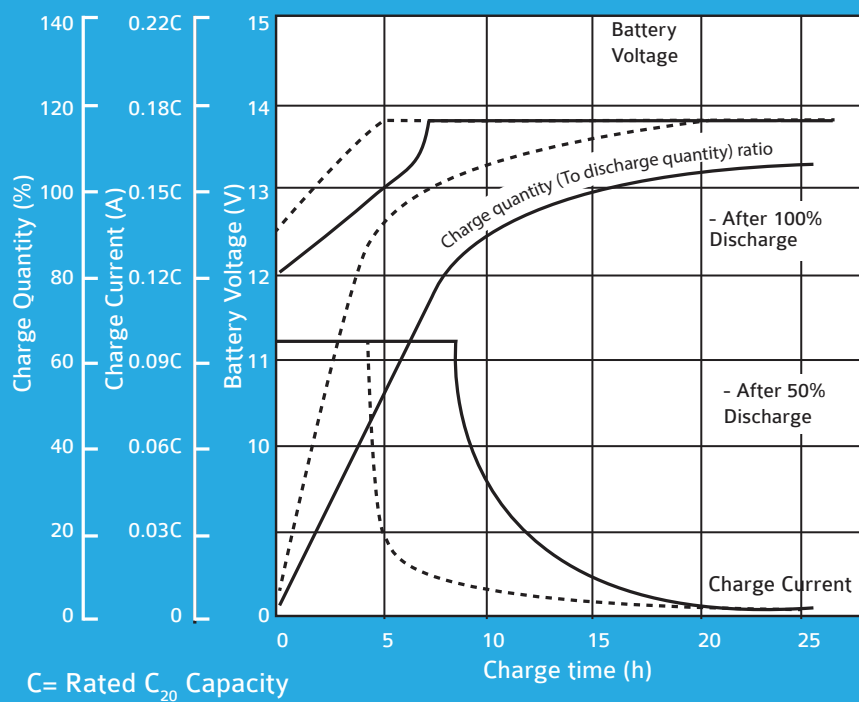

Figure (4)



## SERVICE LIFE

The trend of Service life of EP batteries under different operating conditions

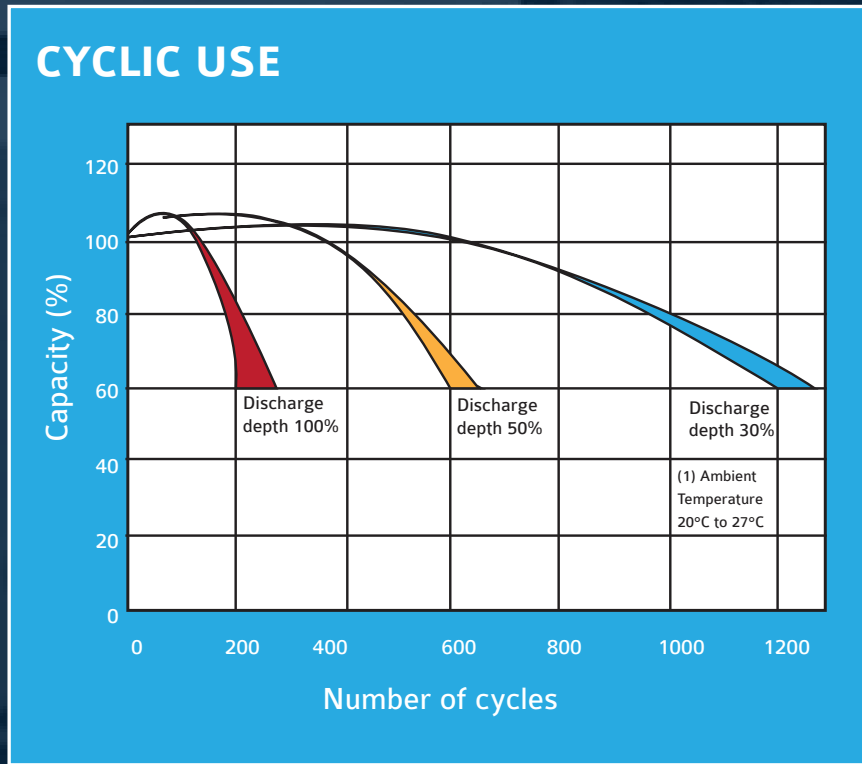

Figure (5)

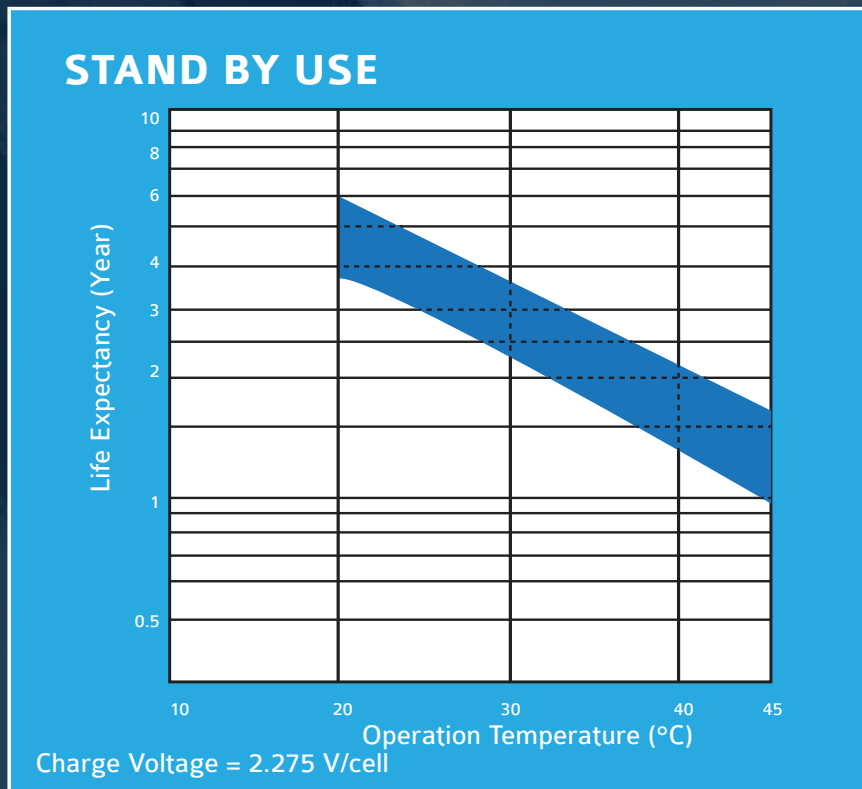
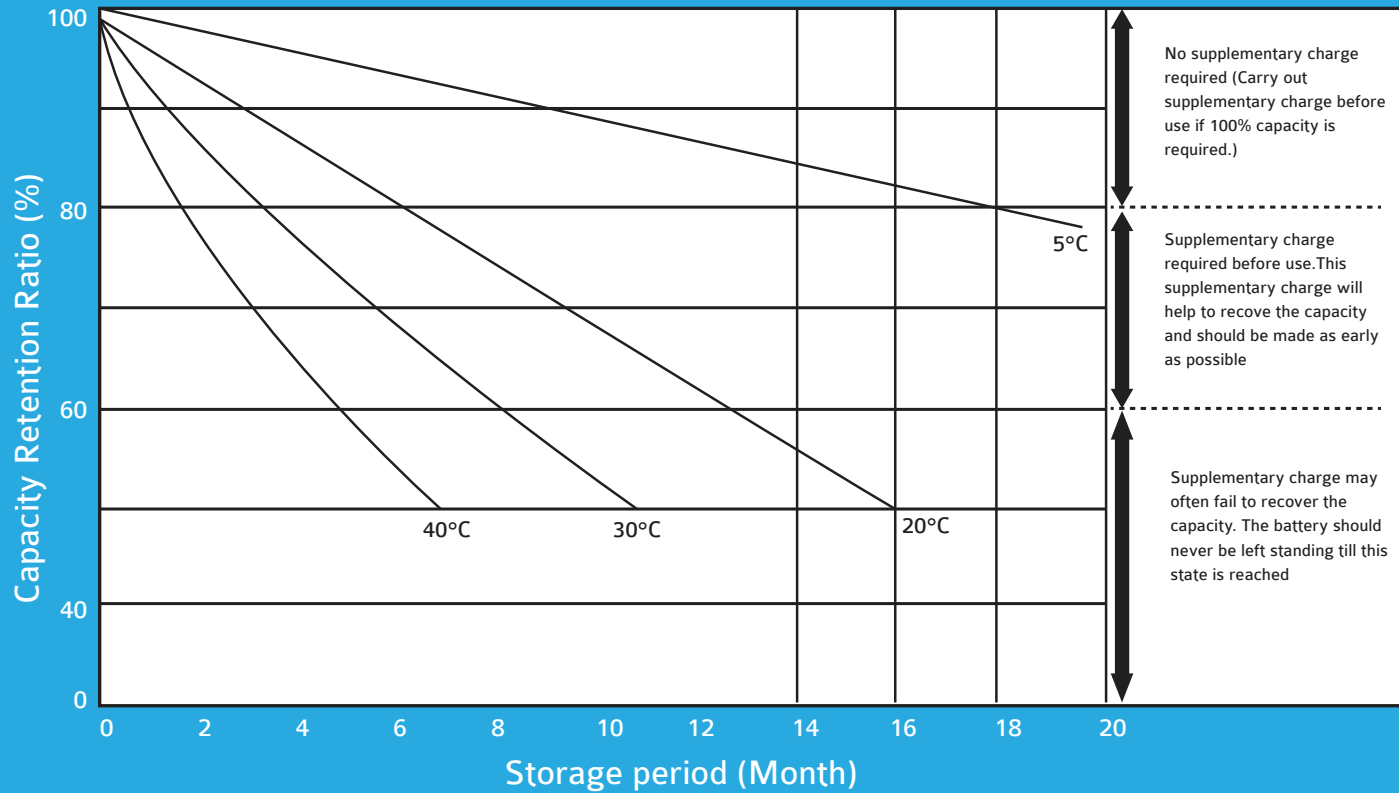

Figure (6)



### Retention of Charges of EP Series under ideal storage conditions



Capacity retention characteristics and the supplementary charge and storage guideline

Figure (7)



Maximum discharge current for various duration and cut off voltage  
Discharge current in ampere to each voltage on EP type sealed lead acid battery

End Voltage /Cell	Temp °C	DISCHARGE TIME																			
		0.5min.	1min.	2min.	3min.	4min.	5min.	7min.	10min.	15min.	20min.	30min.	1hrs.	1.5 hrs.	2hrs.	3hrs.	4hrs.	5hrs.	6hrs.	8hrs.	10hrs.
1.80	25	4.0C (3.2C)	3.9C (3.15C)	3.8C (3.1C)	3.7C (3.0C)	3.5C (2.8C)	3.2C (2.6C)	2.8C (2.3C)	2.3C (2.0C)	1.8C (1.65C)	1.5C (1.4C)	1.1C	0.64C	0.42C	0.36C	0.270C	0.210C	0.170C	0.145C	0.110C	0.090C
	5	3.2C (2.55C)	3.0C (2.4C)	2.7C (2.35C)	2.5C (2.3C)	2.3C (2.15C)	2.2C (2.0C)	1.9C (1.8C)	1.75C (1.65C)	1.4C (1.3C)	1.2C (1.1C)	0.95C	0.59C	0.34C	0.29C	0.230C	0.182C	0.147C	0.129C	0.098C	0.080C
	-5	2.5C (2.1C)	2.4C (2.05C)	2.2C (2.0C)	2.1C (1.95C)	1.9C (1.8C)	1.8C (1.6C)	1.6C (1.5C)	1.4C (1.3C)	1.1C (1.0C)	0.96C (0.86C)	0.76C	0.48C	0.28C	0.24C	0.198C	0.154C	0.125C	0.115C	0.087C	0.071C
1.70	25	5.6C (4.3C)	5.1C (4.2C)	4.9C (4.0C)	4.3C (3.7C)	4.0C (3.4C)	3.6C (3.2C)	3.0C (2.75C)	2.5C (2.3C)	1.9C (1.8C)	1.6C (1.5C)	1.15C	0.67C	0.48C	0.40C	0.290C	0.230C	0.190C	0.165C	0.130C	0.108C
	5	5.1C (3.8C)	4.6C (3.65C)	3.9C (3.4C)	3.4C (3.15C)	3.0C (2.8C)	2.8C (2.5C)	2.4C (2.1C)	2.0C (1.8C)	1.6C (1.5C)	1.3C (1.2C)	1.0C	0.62C	0.39C	0.32C	0.250C	0.199C	0.164C	0.143C	0.116C	0.096C
	-5	3.6C (2.9C)	3.4C (2.7C)	3.0C (2.65C)	2.8C (2.6C)	2.5C (2.6C)	2.3C (2.0C)	2.0C (1.85C)	1.7C (1.6C)	1.3C (1.2C)	1.1C (1.0C)	0.86C	0.53C	0.32C	0.27C	0.213C	0.168C	0.139C	0.123C	0.103C	0.086C
1.65	25	6.6C (4.85C)	5.9C (4.7C)	5.2C (4.45C)	4.6C (4.05C)	4.2C (3.65C)	3.8C (3.35C)	3.2C (2.85C)	2.7C (2.35C)	2.0C (1.85C)	1.65C (1.55C)	1.2C	0.69C	0.50C	0.41C	0.300C	0.240C	0.200C	0.170C	0.135C	0.110C
	5	5.6C (3.9C)	4.9C (3.8C)	4.1C (3.6C)	3.6C (3.3C)	3.15C (2.9C)	2.95C (2.6C)	2.5C (2.2C)	2.1C (1.9C)	1.7C (1.6C)	1.4C (1.3C)	1.05C	0.64C	0.40C	0.33C	0.260C	0.208C	0.173C	0.147C	0.120C	0.098C
	-5	4.4C (3.1C)	3.9C (3.0C)	3.3C (2.9C)	2.9C (2.7C)	2.6C (2.35C)	2.4C (2.1C)	2.1C (1.9C)	1.7C (1.6C)	1.35C (1.25C)	1.15C (1.05C)	1.88C	0.54C	0.34C	0.27C	0.220C	0.176C	0.147C	0.125C	0.107C	0.087C
1.60	25	7.6C (5.4C)	6.7C (5.2C)	5.6C (4.9C)	4.9C (4.4C)	4.4C (3.9C)	3.9C (3.5C)	3.3C (3.0C)	2.8C (2.4C)	2.1C (1.9C)	1.7C (1.6C)	1.25C	0.7C	0.51C	0.42C	0.310C	0.250C	0.210C	0.180C	0.140C	0.115C
	5	6.1C (4.0C)	5.2C (3.9C)	4.3C (3.75C)	3.8C (3.5C)	3.3C (3.1C)	3.1C (2.75C)	2.6C (2.3C)	2.2C (2.0C)	1.8C (1.7C)	1.5C (1.4C)	1.10C	0.66C	0.41C	0.34C	0.270C	0.216C	0.182C	0.156C	0.125C	0.102C
	-5	5.1 (3.3C)	4.4C (3.2C)	3.5C (3.1C)	3.0C (2.75C)	2.7C (2.4C)	2.5C (2.2C)	2.2C (2.0C)	1.75C (1.65C)	1.4C (1.3C)	1.2C (1.1C)	0.9C	0.55C	0.34C	0.28C	0.227C	0.183C	0.154C	0.132C	0.111C	0.091C

\*The number in bracket shows the discharge current of rated capacity above 17Ah. C is rated capacity at 20 hrs.

Table (3)



## DISCHARGE CURRENT AND RECOMMENDED FINAL DISCHARGE VOLTAGE

Discharge current (A)	Final Discharge Voltage (V/Cell)
0.2 C > (A) or intermittent discharge	1.75
0.2 C < or = (A) < 0.5 C	1.70
0.5 C < or = (A) < 1.0 C	1.55
1.0 C < or = (A)	1.30

Table (4)



## EFFECT OF TEMPERATURE ON CAPACITY

This figure represents the relation between the temperature and discharge capacity

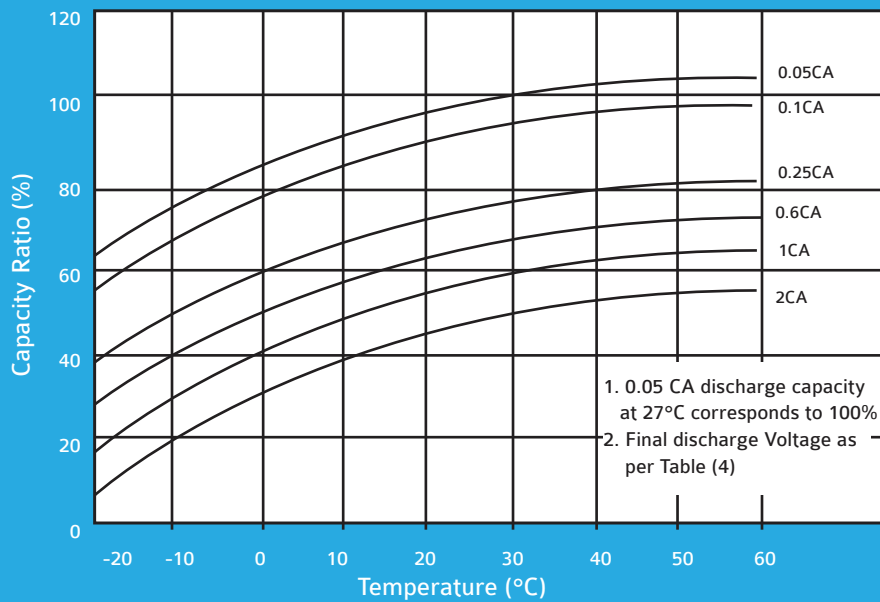

Figure (8)

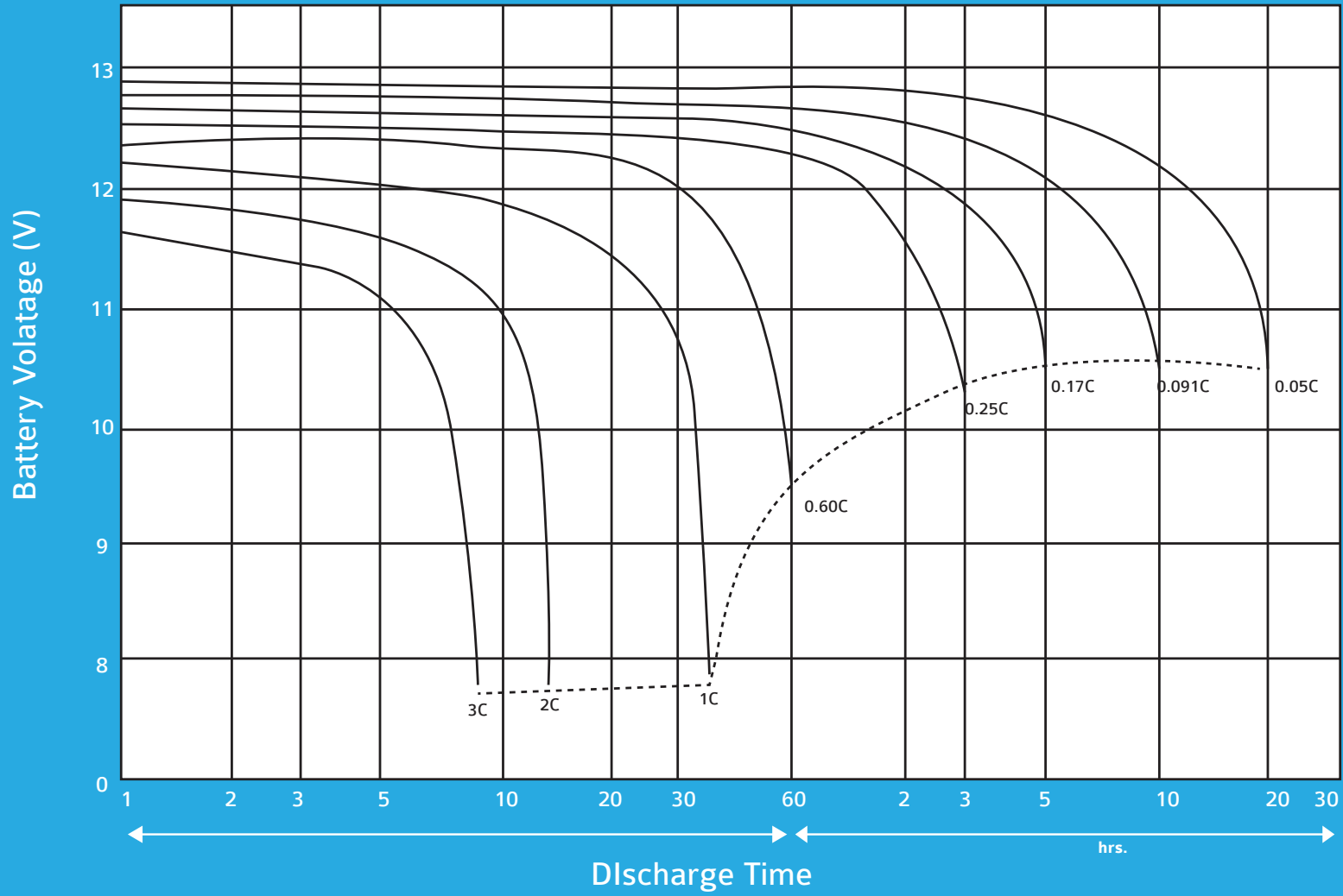

Figure (9)

C = rated  $C_{20}$  Capacity

# CONSTANT POWER DISCHARGE RATING IN WATTS PER BATTERY FOR EP RANGE AT 27°C

END VOLTAGE/CELL	BATTERY TYPE	DISCHARGE TIME												
		5 min	10 min	15 min	20 min	30 min	60 min	120 min	180 min	240 min	300 min	360 min	480 min	600 min
1.80	EP 7-12	284	200	155	128	95	55	33	20.5	16.8	14.0	12.1	9.6	8.0
	EP 9-12/ EP 1234W	297.6	209.1	162.9	134.2	101.3	61.4	38.1	26.5	21.6	18.0	15.7	12.4	10.3
	EP 12-12	486	342	265	219	162	94	56	35	28.8	24.0	20.9	16.5	13.7
	EP17-12	541	376	299	249	184	220	71	50	40.8	34.0	29.9	23.4	19.4
	EP 26-12W	905	637	497	408	293	185	114	76.4	62.4	52.0	45.2	35.6	29.6
	EP 42-12	1393	980	763	629	475	293	180	123.5	100.8	84.0	73.0	58.0	47.9
	EP 65-12	2263	1590	1240	1022	772	470	292	191.1	156.0	130.0	113.1	89.7	74.1
	EP 75-12	2534	1788	1389	1150	864	526	328	216.0	178.0	150.0	130.5	103.5	83.5
	EP 100-12	3307	2323	1810	1491	1125	682	423	294.0	240.0	200.0	174.0	138.0	114.0
	EP 120-12	3968.4	2787.6	2172	1789.2	1350	818.4	507.6	352.8	288	240	208.8	165.6	136.8
	EP 150-12	4960.5	3484.5	2715	2236.5	1687.5	1023	634.5	441	360	300	261	207	171
EP 200-12	6614	4646	3620	2982	2250	1364	846	588	480	400	348	276	228	
1.70	EP 7-12	315	221	168	137	101	57	34	22.2	18.0	14.7	13.0	10.0	8.4
	EP 9-12/ EP 1234W	329.4	231.2	175.3	142.5	108.0	65.2	75.4	28.6	23.2	18.9	16.7	13.0	10.8
	EP 12-12	539	378	287	234	173	97	58	38.1	31.0	25.2	22.3	17.3	14.4
	EP17-12	600	421	321	262	194	117	73	54.0	43.9	35.7	31.6	24.5	20.4
	EP 26-12W	1006	705	536	436	313	193	117	82.7	67.1	54.6	48.3	37.4	31.2
	EP 42-12	1548	1084	825	671	507	305	185	133.5	108.3	88.2	78.1	60.5	50.4
	EP 65-12	2510	1761	1340	1090	823	496	300	206.7	167.7	136.5	120.9	93.6	78.0
	EP 75-12	2816	1988	1500	1220	921	555	337	238.5	193.5	157.5	139.5	108.0	90.0
	EP 100-12	3660	2569	1948	1583	1200	724	438	318.0	258.0	210.0	186.0	144.0	120.0
	EP 120-12	4392	3082.8	2337.6	1899.6	1440	868.8	525.6	381.6	309.6	252	223.2	172.8	144
	EP 150-12	5490	3853.5	2922	2374.5	1800	1086	1257	477	387	315	279	216	180
EP 200-12	7320	5138	3896	3166	2400	1448	1676	636	516	420	372	288	240	
1.60	EP 7-12	332	227	174	141	103	59	35	23.1	18.5	15.4	13.4	10.5	8.4
	EP 9-12/ EP 1234W	345.1	217.4	181.4	145.6	108.6	67.4	40.5	29.7	23.8	19.8	17.3	13.5	10.8
	EP 12-12	569	389	298	241	176	101	59	39.6	31.7	26.4	23.0	18.0	14.4
	EP17-12	632	434	334	270	200	123	77	56.1	44.5	37.4	32.6	25.5	20.4
	EP 26-12W	1059	716	556	449	320	200	119	85.8	68.6	57.2	50.0	39.0	31.2
	EP 42-12	1630	1022	857	690	517	316	190	138.6	110.9	92.4	80.6	63.0	50.4
	EP 65-12	2644	1660	1393	1121	840	513	308	214.5	171.6	143.0	124.8	97.5	78.0
	EP 75-12	2961	1867	1560	1255	940	577	345	244.5	196.0	165.0	141.0	112.5	90.0
	EP 100-12	3834	2416	2015	1618	1207	749	450	330.0	264.0	220.0	192.0	150.0	120.0
	EP 120-12	4600.8	2899.2	2418	1941.6	1448.4	898.8	540	396	316.8	264	230.4	180.0	144.0
	EP 150-12	5751	3624	3022.5	2427	1810.5	1123.5	675	495	396	330	288	225	180
EP 200-12	7668	4832	4030	3236	2414	1498	900	660	528	440	384	300	240	

Table (5)



## ADDITIONAL INFORMATION REGARDING CEIL POWERSAFE

### Heat Dissipation:

A VRLA battery under normal float condition shall dissipate heat into the atmosphere. For the overall heat load calculation, taking into account a worst case operation, the rate of heat dissipation may be taken as 0.45 Watts/100 Ah C20 capacity/cell.

### Hydrogen Evolution:

Hydrogen gas evolved by a lead acid battery may be estimated from the following formula:

Hydrogen gas evolved per hour =  $0.45 \times 10^{-3} \times n \times I \times C$  m<sup>3</sup>  
at N.T.P.

where, n = number of 2V cells

I = Float current, 0.2 A/100 AH for a VRLA cell

C = C20 capacity of cell

To design for the ventilation (air flow) requirement so that the hydrogen percentage in the air is always below 4% (lower explosive limit), the air flow rate may be estimated as:

$Q = d \times s \times 0.45 \times 10^{-3} \times n \times I \times C$  m<sup>3</sup> /hr

Where, d = dilution ratio  $(100 - 4)/4 = 24$

S = factor of safety, eg. 5

For a VRLA, the above may be simplified as:

$Q = 0.0108 \times n \times C$

### Ripple Current:

VRLA batteries should be charged by pure D.C. source only. For optimum life the A.C. ripple content should not exceed 5A per 100Ah C20 capacity.

### Overdischarge:

Compared to the alkaline battery, the sealed lead acid battery is very sensitive to overdischarge. And overdischarge results in failure to recover normal capacity, reduced capacity or shortened service life. Overdischarge also occurs by leaving the battery in a discharge state. The EP type sealed lead acid battery overcomes this, if this battery is overdischarged and left standing in a discharged state for several days, it can recover its original capacity when recharged.

However, it is necessary to avoid overdischarge situations as much as possible. Also check the following points when charging.

### Precautions:

- The original capacity can be recovered after two to three consecutive overdischarges or leaving the battery in discharge state. Beyond this limit, the battery may not recover to its original capacity.
- Always perform constant voltage charging with a 2.45V/cell or constant current charging with 0.05 CA. The charge voltage of 2.275V/cell may not be enough to recover to the capacity above. In this case repeat charge and discharge two or three times.

Figure 10 shows an example of the charge characteristic after overdischarge and leaving the battery in a discharge state. As this figure shows, the charge current may not flow in the initial period of charge. This is not abnormal since the charge flows as charging continues.

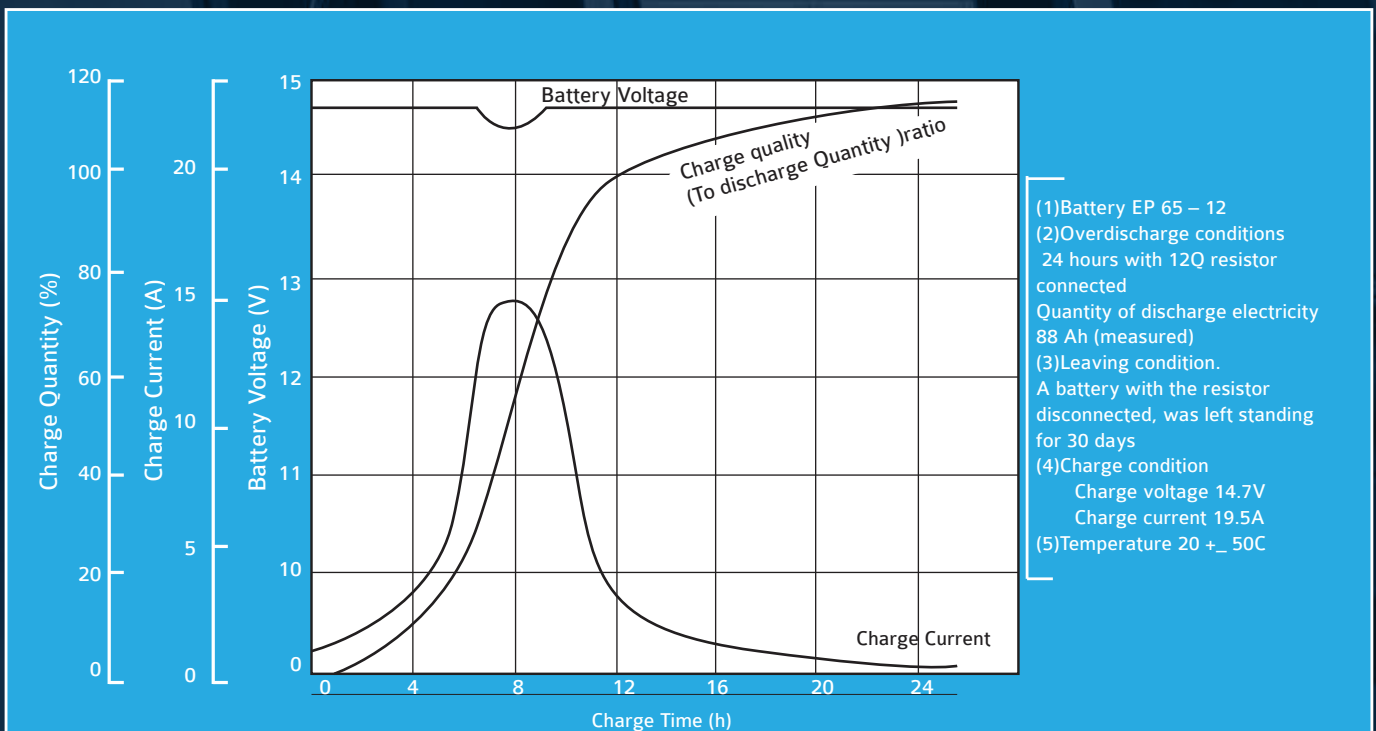

Figure (10)



## OPERATING MANUAL FOR THE EP TYPE SEALED MAINTENANCE FREE BATTERY

This manual describes precautions to be observed when operating the EP sealed lead acid battery (henceforth called the “batter”) which requires no water addition.

### General Handling Precautions Before Usert

#### A. Storage and Supplementary Charging

- During storage, the capacity of the battery decreases due to self discharging. Store the battery in a cool dry place, where the monthly average temperature exceeds 27oC(below 30oC), carry out supplementary charging every 3 to 6 months. Where the monthly average temperature falls below 27oC, carry out supplementary charging every 12 months.
- When using a stored battery, always carry out supplementary charging before use.
- For supplementary charging, refer to Table 6.

#### B. Transporting

- When transporting the battery, never allow excessive vibration or jolting.
- We recommend transporting the battery in an upright position.
- When transporting a battery connected to equipment, secure it firmly and keep the circuit open.

### Supplementary Charge parameters

Charging Method	Charge time (h)	Ambient Temperature (°C)
Constant charge Voltage at 2.45 V/cell	6 -12	5 - 35
Constant Charge current at 0.05 CA	6 - 12	

Table (6)

## Precautions for Design of Power Supply Unit

### ● CHARGING

#### A. For Standby Use (Trickle Charge or Float Charge)

- Charge the battery at a constant voltage of 2.275 V/cell (20°C). When charging at an ambient temperature of 5°C or below or 35°C or above, it is necessary to adjust the charge voltage in relation with temperature. The temperature coefficient should be  $-3.3\text{mV}/\text{oC}/\text{cell}$ .
- Initial charge current should be 0.3CA (where C is the nominal capacity value and A is amperes) or less.
- We recommend charging the battery at an ambient temperature between 5 to 35°C to prevent any adverse effects on its service life.

#### B. For Cyclic Life

- Maintain a constant voltage charge at a voltage of 2.45 V/cell (27°C). When charging at an ambient temperature of 5°C or below or 35°C or above, it is necessary to adjust the charge voltage in relation with the temperature. The temperature coefficient should be  $-5\text{mV}/\text{oC}/\text{cell}$ .
- The maximum charge current should be 0.3CA or less.
- To avoid overcharging, on completion of charge we recommend charging to stopped or the constant voltage to be reduced to 2.275V/cell (27°C).
- We also recommend charging the battery at an ambient temperature between 5 to 35°C to prevent any adverse effects on its effective life.
- In case the battery has to be discharged deeply and frequently during use, to avoid poor charging, we recommend the charging time to be extended to as much as 1.5 to 2 times that of usual charging, once every five cycles of discharge & recharge.
- If higher than recommended/faster charge is required, please consult us.

### ● DISCHARGE

- The maximum discharge currents (for 5 seconds) should never exceed the values shown in Table 1.
- Find discharge voltage and discharge current should be as shown Table 3. For a particular discharge rate, never discharge the battery to voltage less than the values shown in this table. Repeated excessive discharging will shorten the battery's life.
- After discharging, immediately recharge the battery. Never leave it discharged. The capacity to hold charge may not be fully recovered if the battery is left discharged for a long period.

## ● INSTALLATION AND CONNECTION

- Secure the battery firmly to protect it from excessive vibration or impact.
- When placing the battery in equipment, keep it away from heat generating parts (e.g. transformer) and install it in an upright position and as low a position in the equipment as possible. We recommend providing adequate ventilation in the cubicle.
- The battery may release a combustible gas under overcharge/high ambient. Avoid installation in closed equipment or near equipment which may produce sparks (i.e. near a switch or fuse).
- Using vinyl chloride sheathed wire or vinyl chloride sheet may crack the battery container and cover. Either keep it away from the battery or use a non plasticizing vinyl chloride material.
- Never bend the battery terminal nor solder directly.
- Avoid using the battery in the following places :
  - a) Areas exposed to direct sunlight.
  - b) Areas where there is excessive radioactivity, infrared radiation or ultraviolet radiation.
  - c) Areas filled with organic solvent vapour, dust, salt or corrosive gases.
  - d) Areas of abnormal vibration.
- When connecting the battery to a charger or a load, keep the circuit switch OFF and connect the battery (+) pole to the (+) pole of the charger or the load and the battery's (-) pole to the (-) pole of the charger or the load.
- Never use batteries of different capacities, batteries of different performances or new and old batteries together.
- When batteries are to be used in parallel, please consult us.

## Precautions during the application with the UPS systems

### Ambient temperature and installation place

- (1) Use the battery in an environment where the ambient temperature is within the range of 0 to 45°C.
- (2) In case where more than one battery is used, the difference in temperature between batteries must be within 3°C.
- (3) The battery must be kept away from the heat source of equipment.
- (4) Install the battery at the lowest level of the equipment.
- (5) Install the battery at a well-ventilated place in the structure. The ventilation ports must be provided at upper and lower levels with enough distance.
- (6) The battery case is made of plastic resin (ABS or PP resin). Ensure that it is not affected by organic solvent, oil, plasticizer etc. When fixing the battery, care must be exercised not to expose it to uneven load of screws etc.

### Miscellaneous

- (1) New and old batteries must not be used together in series. The time difference in product lots between batteries in a battery bank, must be within one month.
- (2) Store batteries under as low a temperature as possible. Even when batteries are kept under normal temperature, supplementary charging must be done at least once every six months.

## Daily Inspection and Servicing

- When the following abnormalities are observed, discover the cause and replace any defective batteries :
  - a) Any voltage abnormalities
  - b) Any physical defects (e.g. a cracked or deformed container or cover)
  - c) Any electrolyte leakage
  - d) Any abnormal temperatures
- Clean any dust deposition with a wet cloth. Never use organic solvents (e.g. gasoline or thinners). Otherwise the container or cover may develop cracks.
- When installing the battery as an emergency power supply for fire-fighting equipment, inspect it according to the Fire-fighting Equipment Emergency Power Supply Inspection Standard or Inspection Procedure.

## Other Precautions

- The battery may produce a combustible gas. To prevent a rupture never place the battery near or in fire.
- Never short circuit the terminals. Shorting may cause the battery to burn.
- Never disassemble or reassemble the battery.
- If the battery cracks and dilute sulphuric acid comes in contact with skin or clothing, wash it off immediately with water. If dilute sulphuric acid comes in contact with one's eyes, wash them with a lot of water and see a doctor.
- Never attempt to reverse charge the battery. This not only fails to charge the battery, but also diminishes its performance and may cause the electrolyte to leak.

## Life of Battery

Generally the EP battery's effective life is 3 to 5 years for standby use and 200-250 cycles (100% depth of discharge) or more for cyclic use. The effective life may be shortened when the proper conditions are not maintained (i.e. for charging, discharging, working temperature and storage).

## Fastening Bolts and Nuts

In fastening bolts and nuts, the specified torque values be observed to prevent any damage to the terminals.

BOLT AND NUTS SIZE	FASTENING TORQUE
Diameter	N -m
M5	2.5
M6	4.9
M8	12.3

## Disposal of Batteries

Lead acid batteries contain lead, acid and chemicals which are hazardous to the environment. This means that a lead acid battery needs to be disposed of carefully after its useful life is over. However, the hazardous contents are recyclable. Therefore, please return these batteries after use to our dealers or any authorized smelter for careful disposal. This is also as per rules given by Ministry of Environment, Government of India. For further clarifications contact our nearest branch.

## Statutory Notice:

All batteries contain lead, which is harmful for human beings and environment. As per statutory requirements, the used battery must be returned to the authorized dealer, manufacturer or at the designated collection centers.



QUICK  
NOTES

A series of horizontal dashed lines for writing notes.



QUICK  
NOTES

A series of horizontal dashed lines for writing notes.

- Norway
- UK
- Canada
- Croatia
- Poland
- Greece
- Malta
- Israel
- Jordan
- Egypt
- Bahrain
- Qatar
- Peru
- Argentina
- Mali
- Nigeria
- Botswana
- South Africa
- Zambia
- Tanzania
- Mozambique
- Kenya
- Mauritius
- UAE
- Sri Lanka
- Malaysia
- New Zealand
- Australia
- Singapore
- Indonesia
- Brunei
- Philippines
- Thailand
- Cambodia
- Vietnam
- Hong Kong
- Taiwan
- Bangladesh
- China
- Japan
- Korea
- Afghanistan
- Oman
- Kuwait
- Armenia
- Finland
- Germany
- Scotland



\* Wherever we own the brand

# EXIDE

**Exide Industries Limited, India**

**Head Office:** Kolkata: 'Exide House', 59E Chowringhee Road, Kolkata- 700 020  
**Phone:** +91 33 2283 2120 / 2133, **Fax:** +91 33 2283 2637/ 2283 2632

**Corporate Marketing Office:** Kolkata: 6A, Hatibagan Road, Entally, Kolkata- 700 014  
**Phone:** +91 33 2286 6158 / 59, **Fax:** +91 33 2286 6186

**Visit Us at:** [www.exideindustrialbatteries.com/](http://www.exideindustrialbatteries.com/) [www.exide.ind.com](http://www.exide.ind.com)

**Rajib Saha, Mobile:** +91 9903359779

**E-mail:** [RajibS@exide.co.in](mailto:RajibS@exide.co.in)

All data subject to change without notice. No part of this document may be copied or reproduced, electronically or mechanically, without written permission from the company.

DESIGN BY TAXI | TAXICREATIVE.IN