

**Busbar Trunking  
System**  
For every application



**HENIKWON S-Line**  
Busduct System & Solution

## Two companies, one great solution



L&T Electrical & Automation (E&A) is a market leader for electrical distribution, monitoring and control solutions in the low voltage category.

With a wide range of low and medium voltage switchgear, electrical systems, industrial automation, building electrical solutions, energy management solutions, electrical modernization solutions and metering solutions, E&A cater to key sectors of economy like industries, utilities, infrastructure, building and agriculture.

E&A operates five manufacturing facilities - Navi Mumbai, Ahmednagar, Vadodara, Coimbatore and Mysuru in India and another four - Malaysia, Indonesia, UAE and Kuwait outside India. Its manufacturing operations receive support by a well-equipped in-house design and development centres as well as tooling facilities that contribute to precision in manufacturing.



Henikwon Corporation, a unit of E&A in Malaysia, has been producing high-performance low, medium and high-voltage busduct systems for the last three decades. High level of compliance to international standards and skilled pool of engineers and technicians enable it to offer the best-in-class solutions, ideally configured to its customer application.

A continual focus on innovation and customer-driven R&D make Henikwon a leading busduct system manufacturer, and the partner of choice for discerning users.

## Continual R&D, international recognition



Even before our products are subjected to a series of rigorous tests, our state-of-the-art factory ensures consistently high quality.

Busducts are fully type-tested at various independent laboratories, and conforms to international standards. This ensures complete integrity of the entire busduct system.

Our international accreditations affirm our quality standards:

- IEC 61439 - 6 : 2012
- IEC 60529 : 1989/AMD2 : 2013
- IEC 60331 - 21 : 1999
- IEC 60332 - 3 - 10 : 2000
- ISO 834 - 1 : 1999



Manufacturing facility at Ahmednagar



S-Line Busbar Trunking System certified by international agencies and NABL-accredited laboratories like ASTA (Intertek), ERDA, CPRI, SIRIM.

All our manufacturing facilities are compliant to ISO 9001, ISO 14001, OHSAS 18001

## Give your project the S-Line Busduct advantage



Give your prestigious project the advantage of Henikwon S-Line Busduct system – trusted by discerning electrical engineers in 30 countries.

**Longer life:** Each Henikwon S-Line busbar is insulated with Class-F insulation of uniform thickness, which matches metallic expansion and contraction, ensuring that it does not crack or allow moisture to seep in. This means reduced corrosion, and a longer life for your system.

**Higher savings:** A higher joint overlapping area ensures less power loss. More savings – in terms of not just money, but also power, which is becoming scarcer by the day.

**Enhanced safety:** To ensure the highest degree of safety, Henikwon S-Line busduct systems are totally enclosed and well-insulated.



**Greater reliability:** Comprehensive manufacturing processes, strict compliance and selection of inputs give you the assurance of reliability. The Henikwon S-Line busduct system is certified by an independent third party.

Across the years, the Henikwon Busduct system has been installed in several locations in over 30 countries.

## Busduct systems for every need



To meet your entire range of power delivery needs, we offer busduct systems from 250A to 6300A.

Whatever your project, whatever its size, you can rely on us to provide a busduct system that precisely meets your requirements.

### **Residential Apartments**

Reliable power supply in minimum space

### **Hotels, Shopping Centres**

Reliable, safe and flexible design of the power supply system

### **Commercial Complexes, Business Premises**

Low-operating cost and unproblematic retrofitting

### **Airports, Ports, Terminals**

High levels of safety and reliability

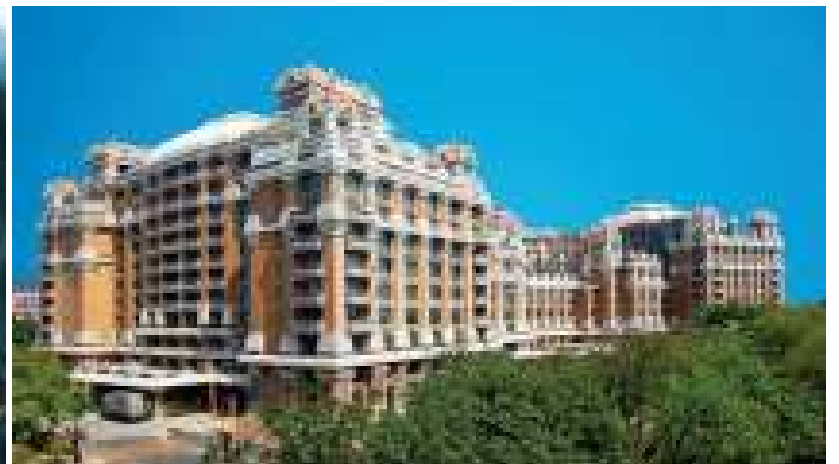

**IT, ITes, Data Centres**

Capable of handling harmonics current effect

**Educational Institutes, Labs**

Simple planning, installation and clear network

**Hospitals**

Maximum supply reliability and consistency

**Power Generation Plants**

Can withstand extreme environmental conditions

**Industries, Assembly Lines**

Rationalised, scope for expansion, flexible

**Metro Rail Station**

Safety and reliability are extremely high

## A legacy of perfect solutions



Your power delivery needs are paramount. E&A and Henikwon's vast experience gives it an insight into them all.

Having undertaken more than 2000 installations in a spectrum of applications across 30 countries, Henikwon's busducts would be the partner of choice for discerning global customers.



**Seismic Zone-5 Test**



**Flame Propagation Test**

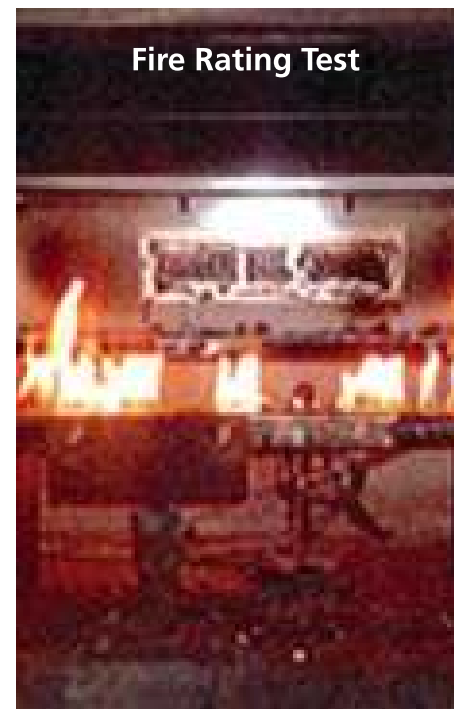

**Fire Rating Test**

Busduct are tested for compliance with Seismic Zone-5, in accordance to IEEE:693-2005 (High Seismic Qualification Level) and IS:1893-2002 standards.

Assembly is tested with combination of Horizontal and Vertical orientation with mounting Plug-in Box in live condition.

Earthquakes occur in almost every region around the world. To restore function of emergency management facilities as quickly as possible. This includes not only buildings, but also the electrical

and mechanical equipment contained therein, as well as machinery necessary for safe occupancy and normal operation.

Busducts also comply for Flame Propagation & Fire Resistance in Building Penetration tests as per requirement of IEC standard.

Fire rated busduct with Fire rating of 1000 degree Celsius for 2 hours available on request. Fire rated busduct are used to connect with emergency load services or places where chances of fire are high.

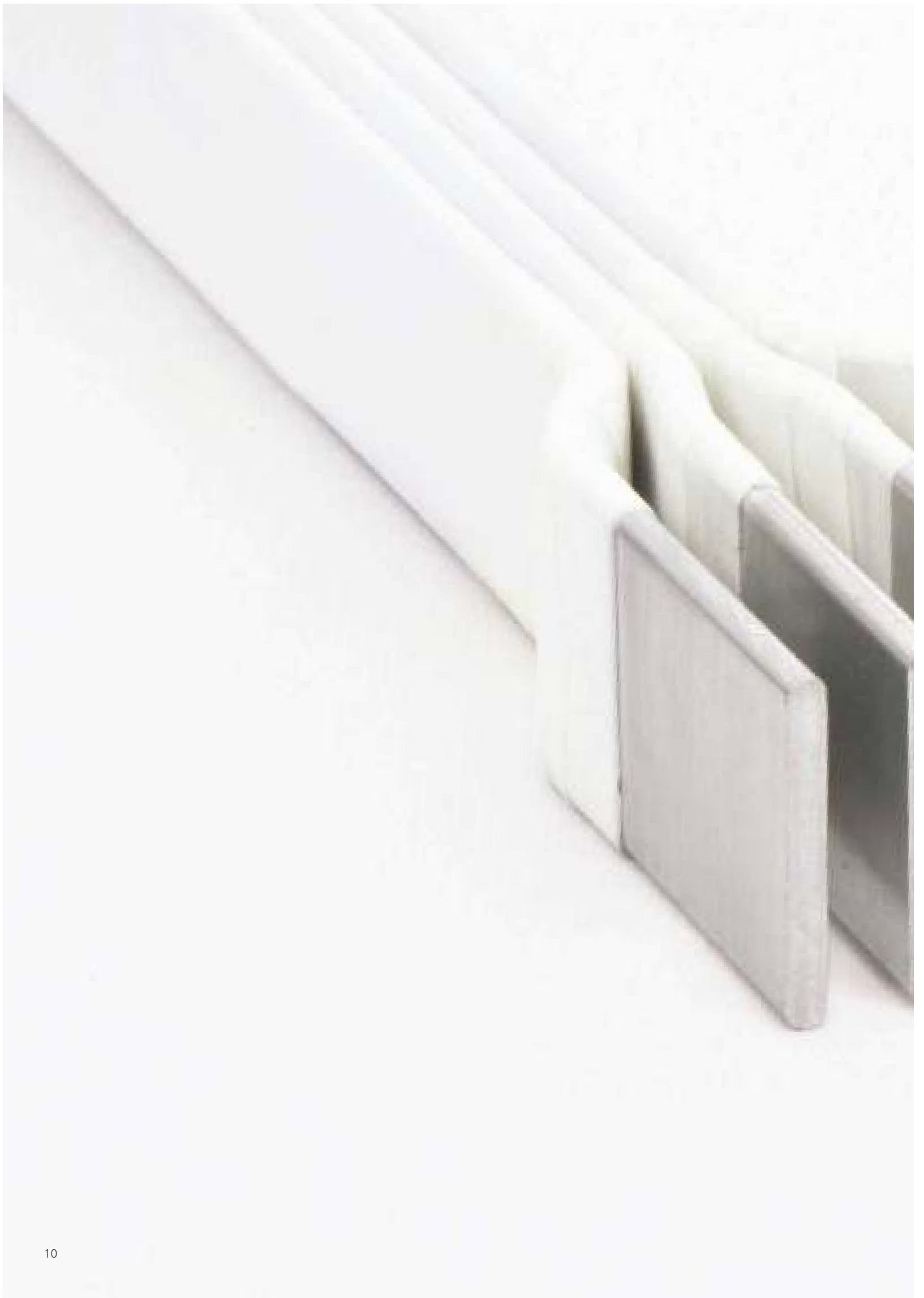



# Index

Busbar Trunking System & Overview	12 - 13
Benefits of Sandwich Busduct System	14
Technical Specifications	15
Electrical Characteristics of Busducts	16 - 18
System Components	19 - 49
Termination Guidelines	50 - 54
Standardisation guidelines	55 - 61
Design Factors for busduct layout	62 - 66
Busduct Mounting Accessories	67 - 69
Installation Guidelines	70 - 86
APPENDIX 1 - Insulation Test Report (Before Installation)	87
APPENDIX 2 - Final Insulation Test Report (Before Energisation)	88
APPENDIX 3 - Pre-commissioning Checklist (Before Energization)	89

## Busbar Trunking System & Overview

A Busduct System is an assembly comprising a system of conductors with one or more bars separated or / and supported by insulating material and contained in a conduit or similar casing.

There are mainly two types of busduct systems based on the type of construction: Air-insulated and Sandwich.

An air-insulated busduct construction has air as an insulation between conductors, hence the overall size of this type of busduct is greater compared to a sandwich busduct. Sandwich construction means that the conductors are individually insulated and mounted so as to resemble a sandwich of conductors and insulation within the busduct casing.

A busduct is manufactured into totally enclosed, pre-fabricated sections consisting of copper or aluminium busbars. Power is simply tapped off by plug-in points positioned at required intervals. Typically, a busduct system will consist of straight lengths, flanged ends, elbows, end feed boxes, end covers, plug-in boxes and other accessories.

The busduct system has several key advantages over conventional forms of power distribution:

- Reduced on-site installation time when compared to a cable system, leading to cost savings.
- Increased flexibility in design and versatility for future modifications.
- Increased safety features brought about by the use of high-quality manufactured components, which provide greater safety.

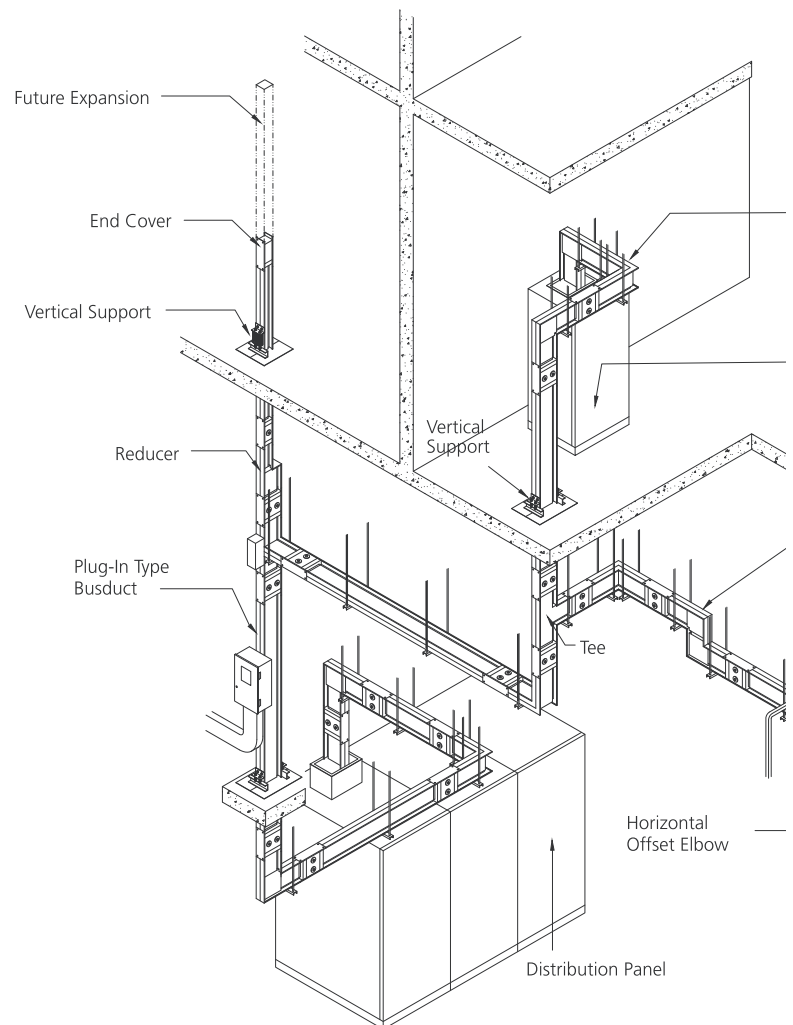

# Busbar Trunking System & Overview

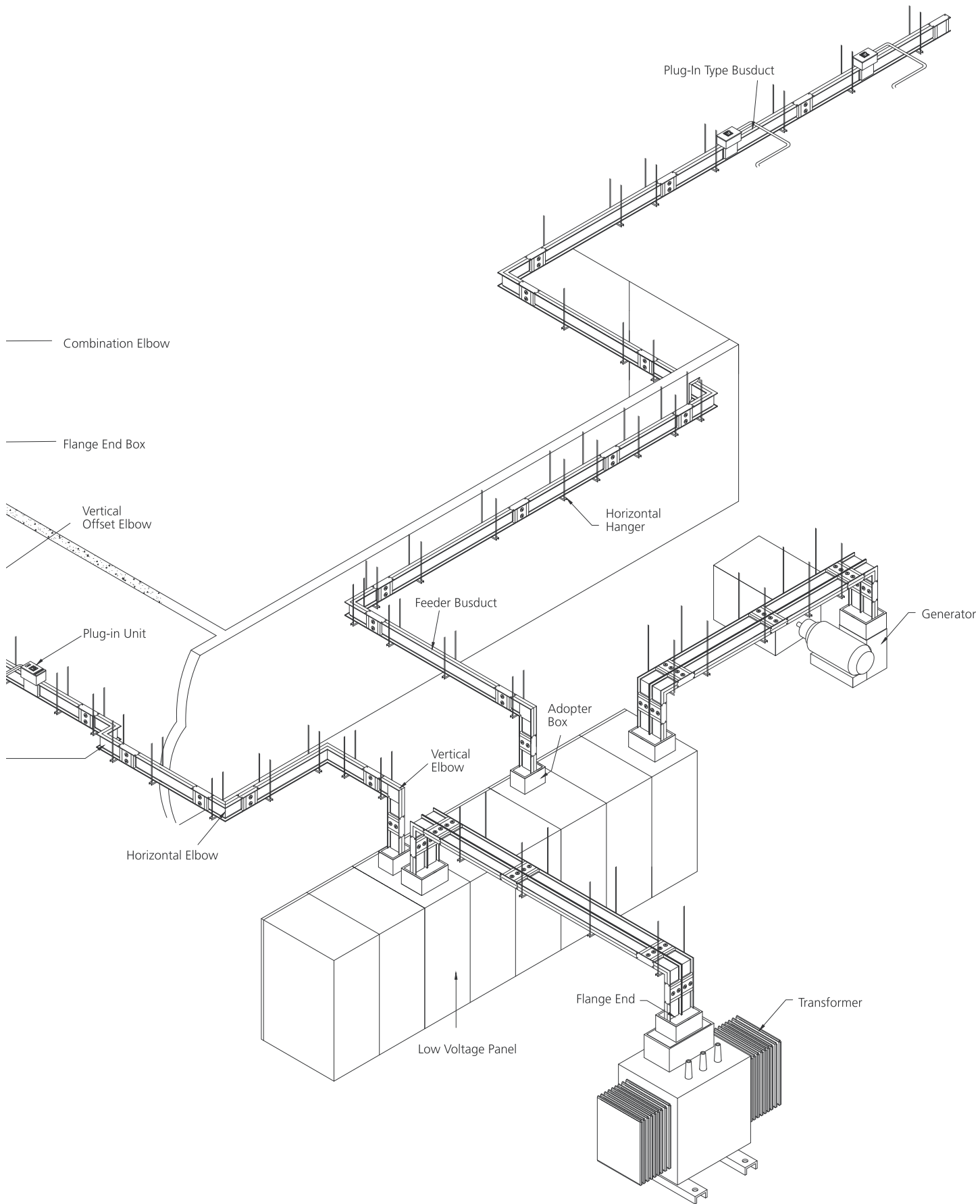

## Benefits of Sandwich Busduct System

---

- Lower impedance of the busduct system results in lower voltage drop as compared to cable and air insulated busduct systems.
- The busduct system is compact in size, resulting in big savings on electrical shaft size, and more usable floor area on every floor.
- Fewer joints in the sandwich busduct system result in savings on installation costs as compared to air insulated busducts.
- The system is simple, compact and adds a touch of elegance to the ambience.
- The sturdy and robust metal enclosure gives it high mechanical strength.
- In a cable system, if the load on any section exceeds the limits, an additional cable has to be run from a spare feeder on the main board to that section; in a busduct system, each plug-in box can normally be added to or removed with the busduct in live condition, eliminating production downtime.
- When used for rising main application or a wall / crossing, the sandwich busduct system negates the need for internal fire barriers, because there is no air gap in the casing to give the chimney effect which would allow the passage of smoke and fire. Better protection against ingress makes sandwich construction more secure against flashover because of ingress.
- Any section of busduct system can be removed without disturbing the adjacent sections.
- Flexible and safe distribution system increases the ease and speed of installation. The system can be dismantled and re-used.
- Sandwich busduct systems have high mechanical strength because of the metal enclosure, and therefore have higher short-circuit withstand capacity compared to cables.

## Technical Specifications

Applicable Standard	IEC 61439 - 6 : 2012
Busduct Construction	Sandwich Type
Busduct Rating	Aluminium - 250A to 6300A Copper - 400A to 6300A
Rated Operational Voltage (Ue)	415V / 690V and maximum up to 1000V
Rated Insulation Voltage (Ui)	1000 V
Rated Impulse Voltage (Uimp)	8kV / 12kV (1.2/50 $\mu$ s)
Rated Dielectric Voltage	2.5kV for 5 sec
Rated Frequency	50Hz / 60Hz
Pole Configurations	3P3W / 3P4W (50%N) / 3P4W (100%N) / 3P5W (200%N) with or without 50% internal earth and provision for mounting external earth
Insulation Class	Class-F (155 degree C)
Insulation Material	Multilayer Polyethylene Terephthalate (UL listed)
Enclosure Material	Aluminium Busduct - 1.6mm GI or 2.5mm AL Copper Busduct - 2.5mm AL
Surface Coating on Enclosure	Epoxy Powder Coating
Paint Shade	RAL 7032
Degree of Protection	IP54 / IP55 for Indoor and IP66 for Outdoor
Plug-in Box	16A to 630A
Tap-off Box	125A to 1250A
Joint Block	Uniblock joint with twin-headed maintenance-free nut
Seismic Compliance	Zone 5, as per IS 1893 (Part 1) - 2002 and IEEE 693 - 2005 Tested with Vertical+Horizontal busduct and Plug-in Box assembly
Fire Resistance in Building Penetration	Verified for Integrity: 240 minutes
Resistance to Flame Propagation	Verified

# Electrical Characteristics of Busducts

## Dimensions (Aluminium Busduct)

Rating (A)	Dimensions (mm) <sup>#</sup>			Weight (kg/m) <sup>*</sup>		
	Conductor Size	Height (H)	Width (W)	Indoor Busduct		
				3W	4W	5W
250A	1-6x30	135	70	7	7	8
400A	1-6x40	135	80	8	9	9
630A	1-6x60	135	100	10	11	12
800A	1-6x80	135	120	11	13	14
1000A	1-6x100	135	140	13	15	16
1250A	1-6x125	135	165	15	17	19
1600A	1-6x150	135	190	17	19	22
2000A	1-6x200	135	240	21	25	28
2500A	1-6x250	135	290	25	29	33
3200A	2-6x150	135	380	34	38	44
4000A	2-6x200	135	480	42	50	56
5000A	3-6x200	135	720	63	75	84
6300A	3-6x250	135	870	75	87	99

#:All dimensions are with tolerances of +/-5 mm  
 \*:Weight is for straight feeder and is with tolerance of +/-5%

## Dimensions (Copper Busduct)

Rating (A)	Dimensions (mm) <sup>#</sup>			Weight (kg/m) <sup>*</sup>		
	Conductor Size	Height (H)	Width (W)	Indoor Busduct		
				3W	4W	5W
400A	1-4x40	135	78	8	10	11
630A	1-6x40	135	78	10	12	14
800A	1-6x50	135	88	12	15	18
1000A	1-6x55	135	93	13	16	19
1250A	1-6x75	135	113	17	21	25
1600A	1-6x102	135	140	23	28	33
2000A	1-6x140	135	178	30	37	45
2500A	1-6x175	135	213	37	46	55
3200A	2-6x102	135	280	49	56	70
4000A	2-6x140	135	356	60	75	89
5000A	2-6x175	135	426	74	92	111
6300A	3-6x160	135	594	102	127	152

#:All dimensions are with tolerances of +/-5 mm  
 \*:Weight is for straight feeder and is with tolerance of +/-5%

## Short Circuit Withstand Capacity

Rating (A)	Short Circuit Rating (kA for 1 Sec)	
	Aluminium	Copper
250A	18	-
400A	25	25
630A	40	40
800A	50	50
1000A	50	50
1250A	65	65
1600A	80	80

Rating (A)	Short Circuit Rating (kA for 1 Sec)	
	Aluminium	Copper
2000A	80	80
2500A	80	100
3200A	100	100
4000A	100	100
5000A	100	100
6300A	100	100

## Electrical Characteristics of Busducts

### Impedance at 50Hz (Aluminium Busduct)

Ampere(A)	Conductor(mm)	(Unit: $\mu\Omega/m$ )		
		Resistance(Rac)	Reactance(X)	Impedance(Z)
250A	1-6x30	197.61	30.51	199.95
400A	1-6x40	149.68	25.01	151.76
630A	1-6x60	100.78	18.84	102.53
800A	1-6x80	76.33	15.46	77.88
1000A	1-6x100	61.65	13.34	63.08
1250A	1-6x125	49.79	11.57	51.12
1600A	1-6x150	42.29	10.36	43.54
2000A	1-6x200	32.60	8.82	33.77
2500A	1-6x250	26.79	7.88	27.92
3200A	2-6x150	21.15	5.18	21.78
4000A	2-6x200	16.30	4.41	16.89
5000A	3-6x200	10.87	2.94	11.26
6300A	3-6x250	8.93	2.63	9.31

### Impedance at 50Hz (Copper Busduct)

Ampere(A)	Conductor(mm)	(Unit: $\mu\Omega/m$ )		
		Resistance(Rac)	Reactance(X)	Impedance(Z)
400A	1-4x40	137.81	19.49	139.18
630A	1-6x40	92.79	25.01	96.10
800A	1-6x50	74.95	21.39	77.94
1000A	1-6x55	68.14	20.01	71.02
1250A	1-6x75	50.95	16.16	53.45
1600A	1-6x102	38.53	13.16	40.72
2000A	1-6x140	28.84	10.80	30.80
2500A	1-6x175	23.91	9.48	25.72
3200A	2-6x102	19.27	6.58	20.36
4000A	2-6x140	14.42	5.40	15.40
5000A	2-6x175	11.96	4.74	12.86
6300A	3-6x160	8.57	3.33	9.19

# Electrical Characteristics of Busducts

## Line-to-Line Voltage Drop at 50Hz (Aluminium Busduct)

Ampere(A)	Conductor(mm)	(Unit : V/m)		
		1.00*	0.90*	0.80*
250A	1-6x30	0.0856	0.0828	0.0764
400A	1-6x40	0.1037	0.1009	0.0934
630A	1-6x60	0.1100	0.1079	0.1003
800A	1-6x80	0.1058	0.1045	0.0975
1000A	1-6x100	0.1068	0.1062	0.0993
1250A	1-6x125	0.1078	0.1079	0.1013
1600A	1-6x150	0.1172	0.1180	0.1110
2000A	1-6x200	0.1129	0.1150	0.1087
2500A	1-6x250	0.1160	0.1193	0.1133
3200A	2-6x150	0.1172	0.1180	0.1110
4000A	2-6x200	0.1129	0.1150	0.1087
5000A	3-6x200	0.0941	0.0958	0.0906
6300A	3-6x250	0.0974	0.1002	0.0952

\*Power Factor

## Line-to-Line Voltage Drop at 50Hz (Copper Busduct)

Ampere(A)	Conductor(mm)	(Unit : V/m)		
		1.00*	0.90*	0.80*
400A	1-4x40	0.0955	0.0918	0.0845
630A	1-6x40	0.1012	0.1030	0.0974
800A	1-6x50	0.1039	0.1064	0.1009
1000A	1-6x55	0.1180	0.1213	0.1152
1250A	1-6x75	0.1103	0.1145	0.1092
1600A	1-6x102	0.1068	0.1120	0.1073
2000A	1-6x140	0.0999	0.1062	0.1024
2500A	1-6x175	0.1035	0.1111	0.1075
3200A	2-6x102	0.1068	0.1120	0.1073
4000A	2-6x140	0.0999	0.1062	0.1024
5000A	2-6x175	0.1035	0.1111	0.1075
6300A	3-6x160	0.0935	0.1000	0.0966

\*Power Factor

### Voltage Drop Calculation Formula

$$\Delta V = \sqrt{3} \times I_L \{R(AC) \cos\theta + X \sin\theta\}$$

Where:  $\Delta V$ : Line-to-line Voltage Drop

$I_L$ : Rated Current

$R(AC)$ : AC Resistance at Rated Current ( $\mu\Omega/m$ )

$X$ : Reactance ( $\mu\Omega/m$ )

$\sin\theta$ :  $\sqrt{1 - \cos^2\theta}$

$\cos\theta$ : Load Power Factor

# System Components

## Feeder

Feeder busduct takes power directly from A to B, usually from power transformer / DG set to switchboard, or from switchboard to switchboard

Ampere (A)	Standard Length (mm) S	Minimum Length (mm) S
Aluminium 250A to 2500A	3000	500
Copper 400A to 2500A		

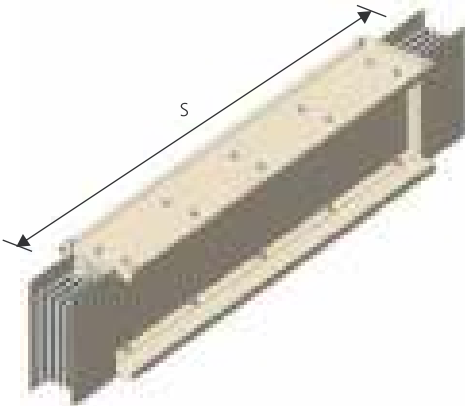

Ampere (A)	Standard Length (mm) S	Minimum Length (mm) S
Aluminium 3200A to 4000A	3000	500
Copper 3200A to 5000A		

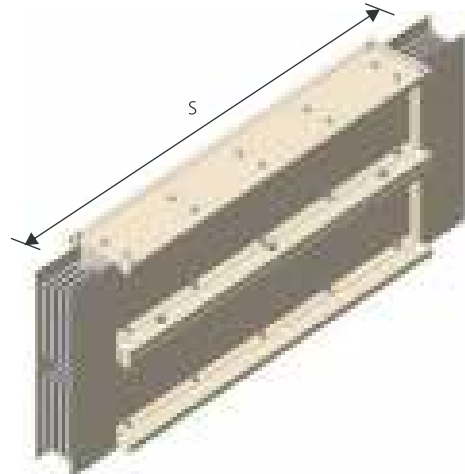

Ampere (A)	Standard Length (mm) S	Minimum Length (mm) S
Aluminium 5000A to 6300A	3000	500
Copper 6300A		

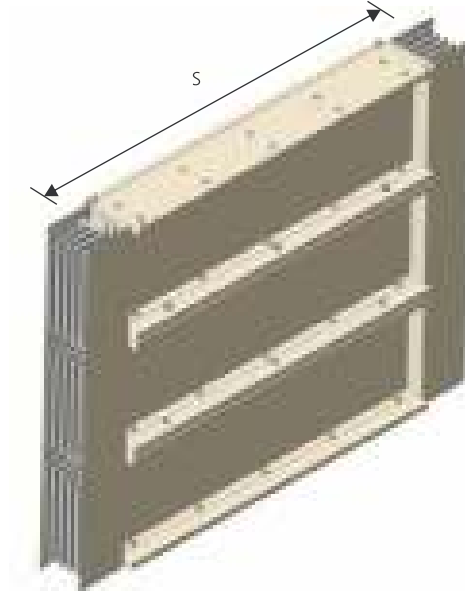

# System Components

## Plug-in Feeder

- Plug-in feeders are used for power distribution
- Power is distributed through plug-in boxes (up to 400A) from plug-in feeder
- Plug-in points shall be as per site requirement (up to a maximum of 5 on either side per 3-metre plug-in feeder)
- The hole positions are determined by the space between the plug-in boxes and the length between the boxes and joint point.

Ampere (A)	Standard Length (mm) S	Minimum Length (mm) S
Aluminium 250A to 2500A	3000	1200
Copper 400A to 2500A		

Ampere (A)	Standard Length (mm) S	Minimum Length (mm) S
Aluminium 3200A to 4000A	3000	1200
Copper 3200A to 5000A		

Ampere (A)	Standard Length (mm) S	Minimum Length (mm) S
Aluminium 5000A to 6300A	3000	1200
Copper 6300A		

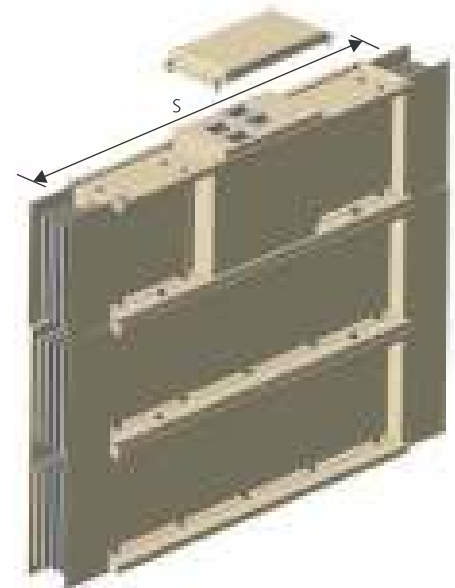
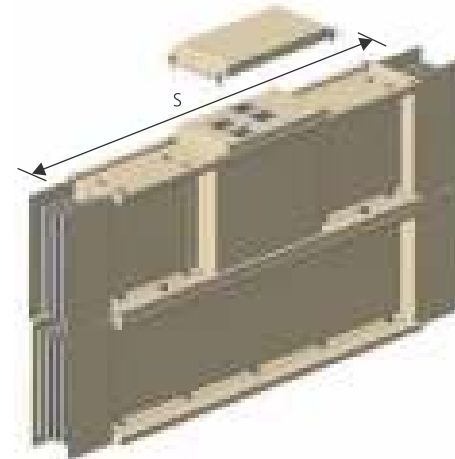
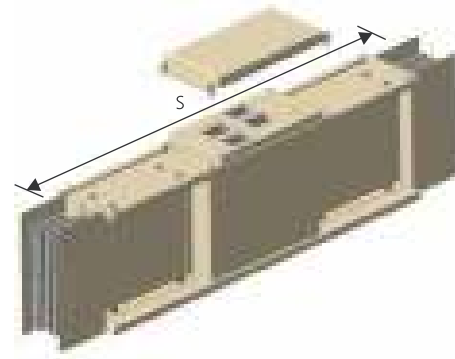

# System Components

## Tap-off Feeder

- Tap-off feeders are used for power distribution
- Power is distributed through tap-off boxes wherever the required power output is between 630A and 1250A
- Tap-off points shall be as per site requirement (up to a maximum of 2 on either side per 3-metre tap-off feeder)

Ampere (A)	Standard Length (mm) S	Minimum Length (mm) S
Aluminium 250A to 2500A	3000	1200
Copper 400A to 2500A		

Ampere (A)	Standard Length (mm) S	Minimum Length (mm) S
Aluminium 3200A to 4000A	3000	1200
Copper 3200A to 5000A		

Ampere (A)	Standard Length (mm) S	Minimum Length (mm) S
Aluminium 5000A to 6300A	3000	1200
Copper 6300A		

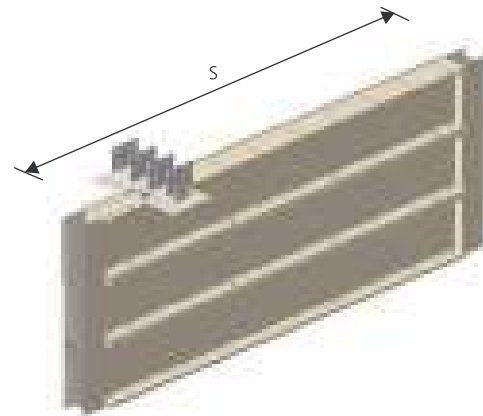
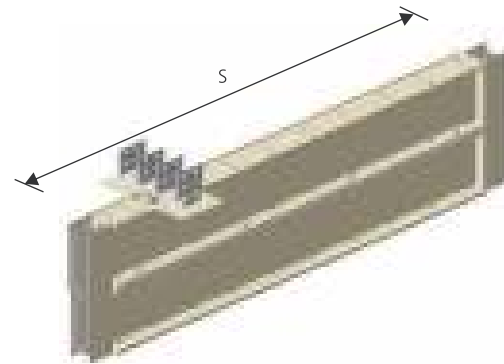
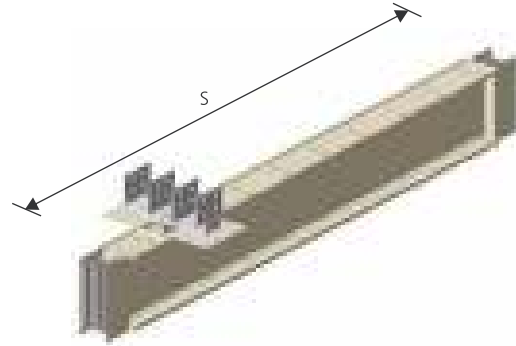

# System Components

## Joint block with Maintenance-free Nut

The Henikwon S-Line busduct system provides a reliable and complete fastening of joint bolts, with a maintenance-free nut system which, as shown in the diagram below, consists of an inner thread and torque limited neck.

An MF nut is fastened by the torque wrench with the required torque. Next, the outer nut head has to be tightened with torque wrench until the neck is twisted off and reaches the locked nut.

Upon fastening and locking of joint bolts, the outer nut will tilt, indicating the safety of the fastened locked nut.

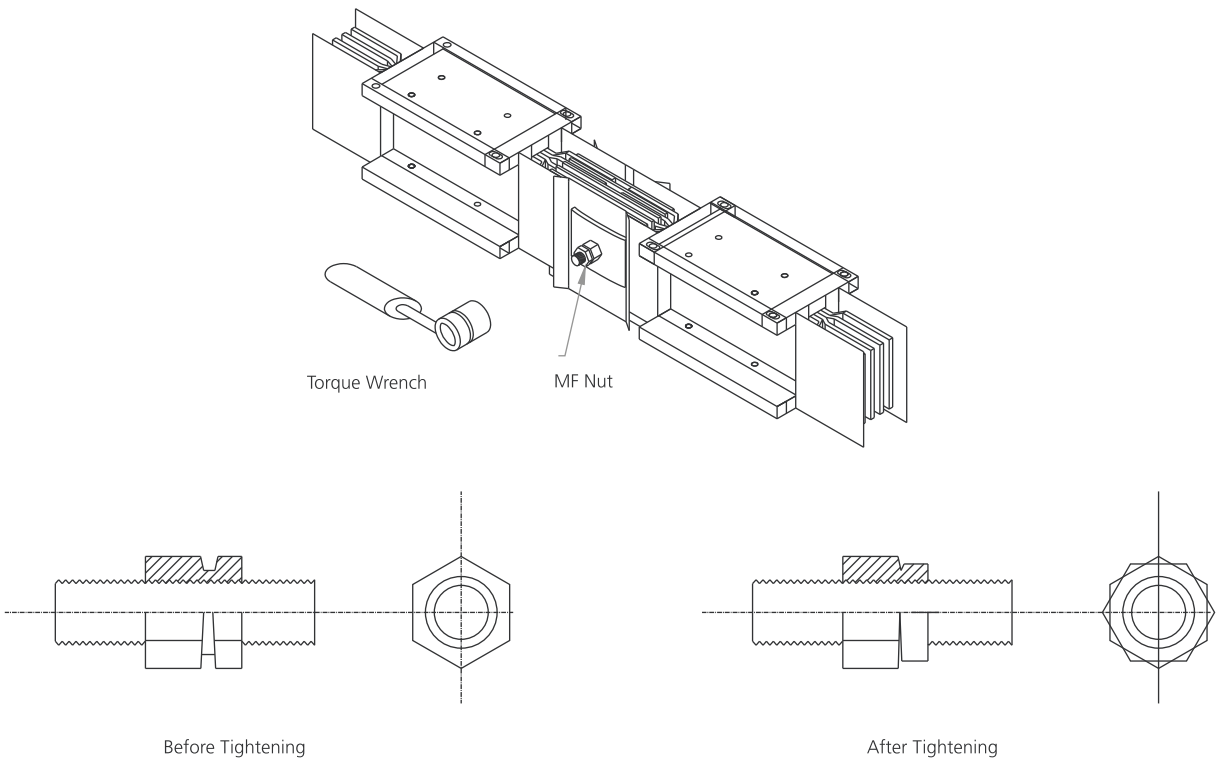

# System Components

## Vertical Elbow

Vertical elbows are used to turn the busduct route up and down if it is running on its edge (when the busbars are vertical) .

Aluminium Busduct			Copper Busduct		
Ampere (A)	Standard Length (mm) S x L	Minimum Length (mm) S x L	Ampere (A)	Standard Length (mm) S x L	Minimum Length (mm) S x L
250A	500 x 500	325 x 325	-	500 x 500	-
400A		330 x 330	400A		330 x 330
630A		340 x 340	630A		330 x 330
800A		350 x 350	800A		335 x 335
1000A		360 x 360	1000A		340 x 340
1250A		370 x 370	1250A		350 x 350
1600A		390 x 390	1600A		365 x 365
2000A		410 x 410	2000A		380 x 380
2500A		440 x 440	2500A		400 x 400

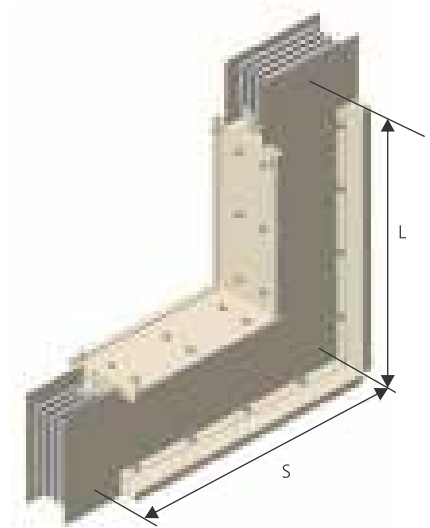

Aluminium Busduct			Copper Busduct		
Ampere (A)	Standard Length (mm) S x L	Minimum Length (mm) S x L	Ampere (A)	Standard Length (mm) S x L	Minimum Length (mm) S x L
3200A	700 x 700	480 x 480	3200A	700 x 700	435 x 435
4000A		530 x 530	4000A		470 x 470
-		-	5000A		505 x 505

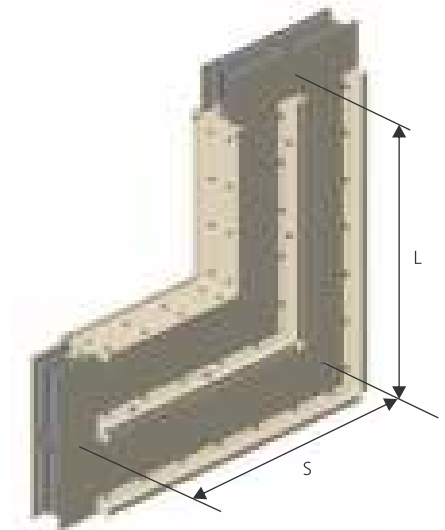

Aluminium Busduct			Copper Busduct		
Ampere (A)	Standard Length (mm) S x L	Minimum Length (mm) S x L	Ampere (A)	Standard Length (mm) S x L	Minimum Length (mm) S x L
5000A	700 x 700	650 x 650	-	-	-
6300A	750 x 750	725 x 725	6300A	700 x 700	590 x 590

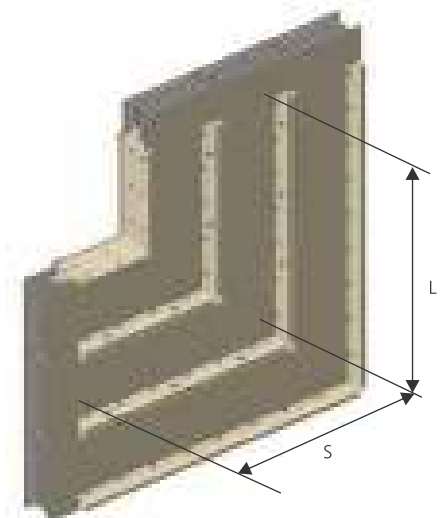

# System Components

## Horizontal Elbow

Horizontal elbows are used to turn the busduct route up and down if it is running when it is flat (when the busbars are horizontal).

Aluminium Busduct			Copper Busduct		
Ampere (A)	Standard Length (mm) S x L	Minimum Length (mm) S x L	Ampere (A)	Standard Length (mm) S x L	Minimum Length (mm) S x L
250A	500 x 500	300 x 300	-	500 x 500	300 x 300
400A			400A		
630A			630A		
800A			800A		
1000A			1000A		
1250A			1250A		
1600A			1600A		
2000A			2000A		
2500A			2500A		

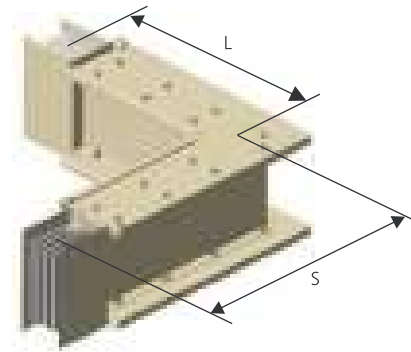

Aluminium Busduct			Copper Busduct		
Ampere (A)	Standard Length (mm) S x L	Minimum Length (mm) S x L	Ampere (A)	Standard Length (mm) S x L	Minimum Length (mm) S x L
3200A	500 x 500	300 x 300	3200A	500 x 500	300 x 300
4000A			4000A		
-			5000A		

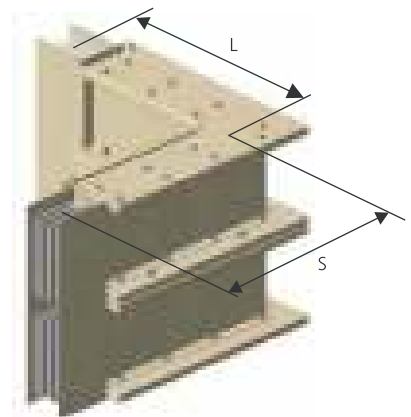

Aluminium Busduct			Copper Busduct		
Ampere (A)	Standard Length (mm) S x L	Minimum Length (mm) S x L	Ampere (A)	Standard Length (mm) S x L	Minimum Length (mm) S x L
5000A	500 x 500	300 x 300	-	-	-
6300A			6300A	500 x 500	300 x 300

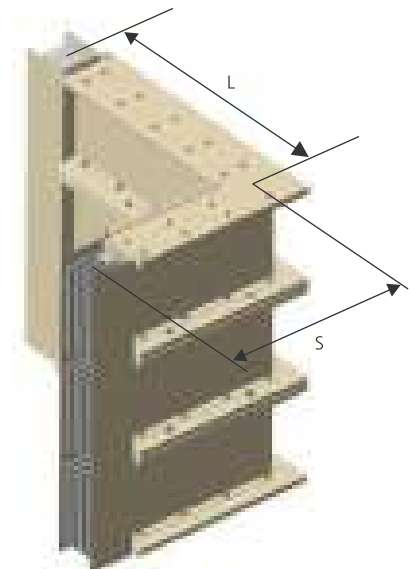

# System Components

## Vertical Offset Elbows

Vertical offset elbows are a combination of two vertical elbows, and are used to avoid vertical obstacles such as pipes, columns and beams.

Aluminium Busduct			Copper Busduct		
Ampere (A)	Standard Length (mm) S x C x L	Minimum Length (mm) S x C x L	Ampere (A)	Standard Length (mm) S x C x L	Minimum Length (mm) S x C x L
250A	500 x 500 x 500	325 x 280 x 325	-	500 x 500 x 500	-
400A		330 x 280 x 330	400A		330 x 275 x 330
630A		340 x 280 x 340	630A		330 x 275 x 330
800A		350 x 290 x 350	800A		335 x 280 x 335
1000A		360 x 310 x 360	1000A		340 x 285 x 340
1250A		370 x 320 x 370	1250A		350 x 295 x 350
1600A		390 x 330 x 390	1600A		365 x 310 x 365
2000A		410 x 360 x 410	2000A		380 x 325 x 380
2500A		440 x 380 x 440	2500A		400 x 345 x 400

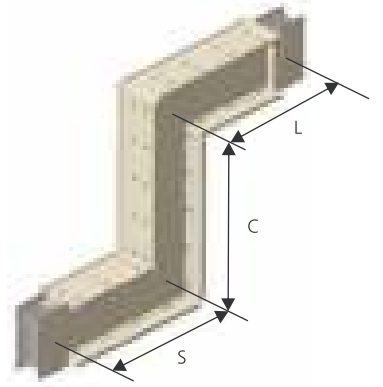

Aluminium Busduct			Copper Busduct		
Ampere (A)	Standard Length (mm) S x C x L	Minimum Length (mm) S x C x L	Ampere (A)	Standard Length (mm) S x C x L	Minimum Length (mm) S x C x L
3200A	750 x 750 x 750	480 x 330 x 480	3200A	750 x 750 x 750	435 x 285 x 435
4000A		530 x 380 x 530	4000A		470 x 320 x 470
-		-	5000A		505 x 355 x 505

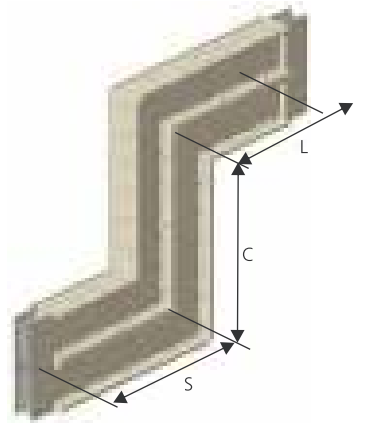

Aluminium Busduct			Copper Busduct		
Ampere (A)	Standard Length (mm) S x C x L	Minimum Length (mm) S x C x L	Ampere (A)	Standard Length (mm) S x C x L	Minimum Length (mm) S x C x L
5000A	750 x 750 x 750	650 x 500 x 650	-	-	-
6300A		725 x 650 x 725		750 x 750 x 750	590 x 440 x 590

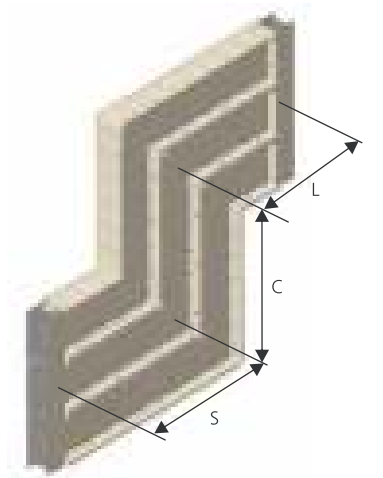

# System Components

## Horizontal Offset Elbows

Horizontal offset elbows are a combination of two horizontal elbows, and are used to avoid horizontal obstacles such as pipes, columns and beams.

Aluminium Busduct			Copper Busduct		
Ampere (A)	Standard Length (mm) S x C x L	Minimum Length (mm) S x C x L	Ampere (A)	Standard Length (mm) S x C x L	Minimum Length (mm) S x C x L
250A	500 x 500 x 500	300 x 250 x 300	-	500 x 500 x 500	300 x 250 x 300
400A			400A		
630A			630A		
800A			800A		
1000A			1000A		
1250A			1250A		
1600A			1600A		
2000A			2000A		
2500A			2500A		

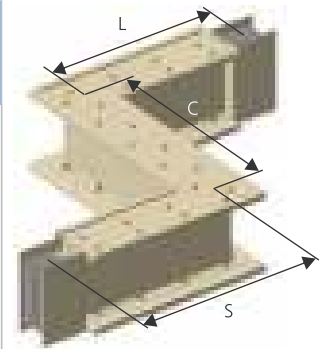

Aluminium Busduct			Copper Busduct		
Ampere (A)	Standard Length (mm) S x C x L	Minimum Length (mm) S x C x L	Ampere (A)	Standard Length (mm) S x C x L	Minimum Length (mm) S x C x L
3200A	500 x 500 x 500	300 x 250 x 300	3200A	500 x 500 x 500	300 x 250 x 300
4000A			4000A		
-			5000A		

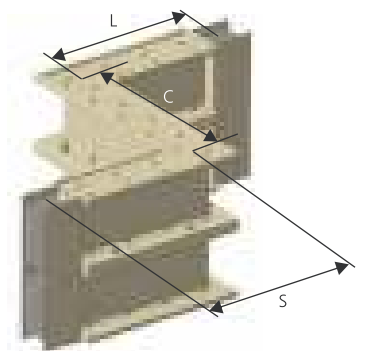

Aluminium Busduct			Copper Busduct		
Ampere (A)	Standard Length (mm) S x C x L	Minimum Length (mm) S x C x L	Ampere (A)	Standard Length (mm) S x C x L	Minimum Length (mm) S x C x L
5000A	500 x 500 x 500	300 x 250 x 300	-	-	-
6300A			6300A	500 x 500 x 500	300 x 250 x 300

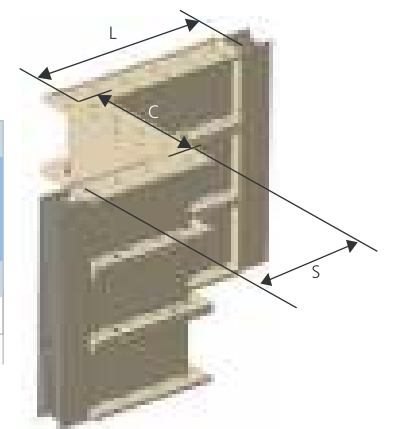

# System Components

## Combination Elbows

Combination elbows are a combination of horizontal and vertical elbows. They are used to avoid obstacles such as pipes, columns and beams, as well as to change the plane of the busbars horizontally or vertically.

Aluminium Busduct			Copper Busduct		
Ampere (A)	Standard Length (mm) S x C x L	Minimum Length (mm) S x C x L	Ampere (A)	Standard Length (mm) S x C x L	Minimum Length (mm) S x C x L
250A	500 x 500 x 500	325 x 325 x 300	-	500 x 500 x 500	-
400A		330 x 330 x 300	400A		330 x 330 x 300
630A		340 x 340 x 300	630A		330 x 330 x 300
800A		350 x 350 x 300	800A		335 x 335 x 300
1000A		360 x 360 x 300	1000A		340 x 340 x 300
1250A		370 x 370 x 300	1250A		350 x 350 x 300
1600A		390 x 390 x 300	1600A		365 x 365 x 300
2000A		410 x 410 x 300	2000A		380 x 380 x 300
2500A		440 x 440 x 300	2500A		400 x 400 x 300

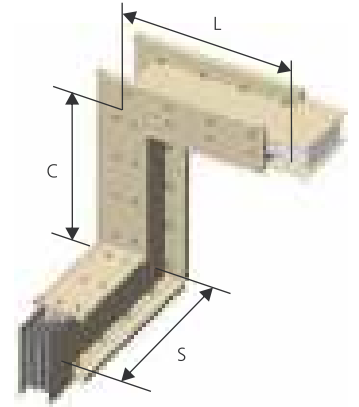

Aluminium Busduct			Copper Busduct		
Ampere (A)	Standard Length (mm) S x C x L	Minimum Length (mm) S x C x L	Ampere (A)	Standard Length (mm) S x C x L	Minimum Length (mm) S x C x L
3200A	700 x 700 x 700	480 x 480 x 300	3200A	700 x 700 x 700	435 x 435 x 300
4000A		530 x 530 x 300	4000A		470 x 470 x 300
-		-	5000A		505 x 505 x 300

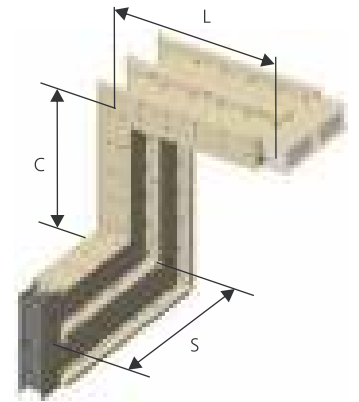

Aluminium Busduct			Copper Busduct		
Ampere (A)	Standard Length (mm) S x C x L	Minimum Length (mm) S x C x L	Ampere (A)	Standard Length (mm) S x C x L	Minimum Length (mm) S x C x L
5000A	700 x 700 x 700	650 x 650 x 300	-	-	-
6300A	750 x 750 x 500	725 x 725 x 300	6300A	700 x 700 x 700	590 x 590 x 300

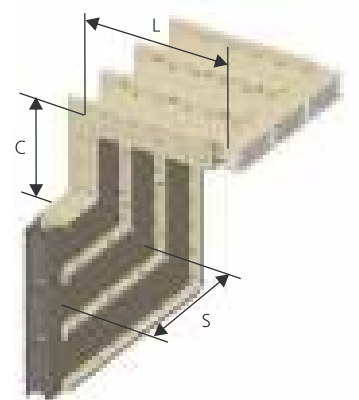

# System Components

## Vertical Tee Elbows

Vertical tee elbows are used to split one busduct run into two runs going in different direction. They are used largely in places where a horizontal power distribution system is required, e.g. factories, malls and data centres.

Aluminium Busduct			Copper Busduct		
Ampere (A)	Standard Length (mm) S x C x L	Minimum Length (mm) S x C x L	Ampere (A)	Standard Length (mm) S x C x L	Minimum Length (mm) S x C x L
250A	500 x 500 x 500	325 x 325 x 325	-	500 x 500 x 500	-
400A		330 x 330 x 330	400A		330 x 330 x 330
630A		340 x 340 x 340	630A		340 x 340 x 340
800A		350 x 350 x 350	800A		340 x 340 x 340
1000A		360 x 360 x 360	1000A		340 x 340 x 340
1250A		370 x 370 x 370	1250A		345 x 345 x 345
1600A		390 x 390 x 390	1600A		365 x 365 x 365
2000A		410 x 410 x 410	2000A		380 x 380 x 380
2500A		440 x 440 x 440	2500A		400 x 400 x 400

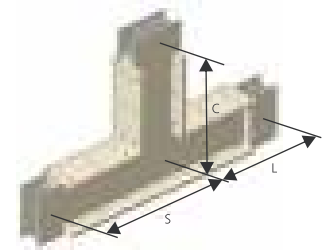

Aluminium Busduct			Copper Busduct		
Ampere (A)	Standard Length (mm) S x C x L	Minimum Length (mm) S x C x L	Ampere (A)	Standard Length (mm) S x C x L	Minimum Length (mm) S x C x L
3200A	750 x 750 x 750	480 x 480 x 480	3200A	500 x 500 x 500	430 x 430 x 430
4000A		530 x 530 x 530	4000A		470 x 470 x 470
-		-	5000A		505 x 505 x 505

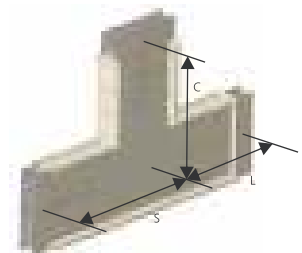

Aluminium Busduct			Copper Busduct		
Ampere (A)	Standard Length (mm) S x C x L	Minimum Length (mm) S x C x L	Ampere (A)	Standard Length (mm) S x C x L	Minimum Length (mm) S x C x L
5000A	750 x 750 x 750	650 x 650 x 650	-	-	-
6300A		725 x 725 x 725	6300A	500 x 500 x 500	590 x 590 x 590

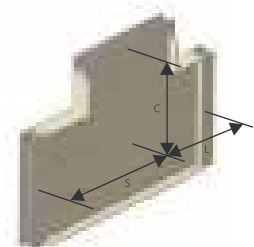

# System Components

## Reducers

Reducers are used to decrease the current-carrying capacity of busducts in the same route. Reducers can be used in vertical as well as horizontal power distribution systems.

Aluminium Busduct			Copper Busduct		
Ampere (A)	Standard Length (mm) S x L	Minimum Length (mm) S x L	Ampere (A)	Standard Length (mm) S x L	Minimum Length (mm) S x L
250A	500 x 500	300 x 300	-	500 x 500	300 x 300
400A			400A		
630A			630A		
800A			800A		
1000A			1000A		
1250A			1250A		
1600A			1600A		
2000A			2000A		
2500A			2500A		

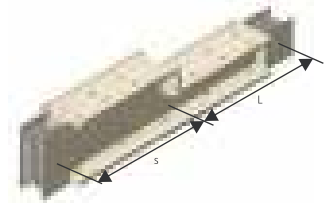

Aluminium Busduct			Copper Busduct		
Ampere (A)	Standard Length (mm) S x L	Minimum Length (mm) S x L	Ampere (A)	Standard Length (mm) S x L	Minimum Length (mm) S x L
3200A	700 x 700	500 x 500	3200A	700 x 700	500 x 500
4000A			4000A		
-			5000A		

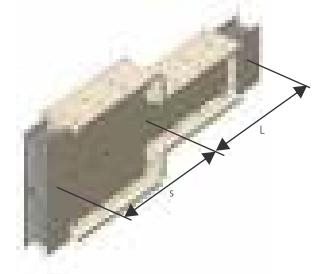

Aluminium Busduct			Copper Busduct		
Ampere (A)	Standard Length (mm) S x L	Minimum Length (mm) S x L	Ampere (A)	Standard Length (mm) S x L	Minimum Length (mm) S x L
5000A	700 x 700	500 x 500	-	-	-
6300A	750 x 750		6300A	700 x 700	500 x 500

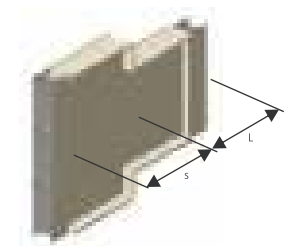

# System Components

## Flanged End

Flanged ends provide a direct connection between the busduct system and transformer / DG set / switchboard / end feed unit through flexibles / links / direct connections.

Aluminium Busduct			Copper Busduct		
Ampere (A)	Standard Length (mm) S	Minimum Length (mm) S	Ampere (A)	Standard Length (mm) S	Minimum Length (mm) S
250A	500	250	-	500	250
400A			400A		
630A			630A		
800A			800A		
1000A			1000A		
1250A			1250A		
1600A			1600A		
2000A			2000A		
2500A			2500A		

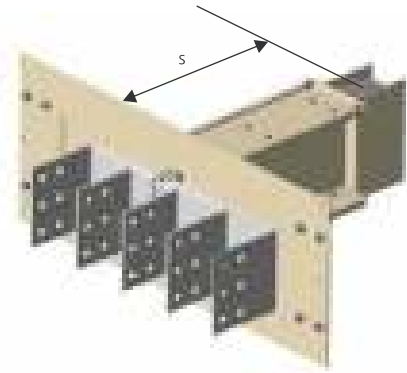

Aluminium Busduct			Copper Busduct		
Ampere (A)	Standard Length (mm) S	Minimum Length (mm) S	Ampere (A)	Standard Length (mm) S	Minimum Length (mm) S
3200A	500	250	3200A	500	250
4000A			4000A		
-	-	-	5000A	-	-

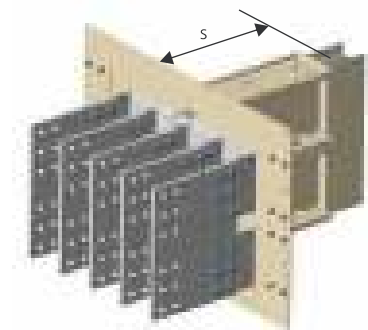

Aluminium Busduct			Copper Busduct		
Ampere (A)	Standard Length (mm) S	Minimum Length (mm) S	Ampere (A)	Standard Length (mm) S	Minimum Length (mm) S
5000A	500	250	-	-	-
6300A			6300A	500	250

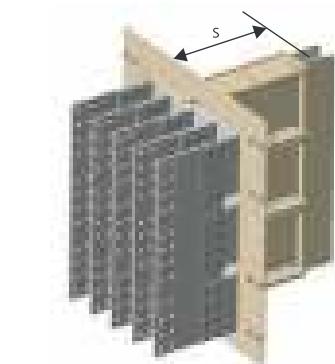

# System Components

## Vertical Elbow with Flanged End

The combined vertical elbow and flanged end is used when standard dimensions of either cannot be individually used.

Aluminium Busduct			Copper Busduct		
Ampere (A)	Standard Length (mm) S x L	Minimum Length (mm) S x L	Ampere (A)	Standard Length (mm) S x L	Minimum Length (mm) S x L
250A	500 x 500	180 x 325	-	500 x 500	-
400A		180 x 330	400A		175 x 330
630A		180 x 340	630A		175 x 330
800A		190 x 350	800A		180 x 335
1000A		210 x 360	1000A		185 x 340
1250A		220 x 370	1250A		195 x 350
1600A		230 x 390	1600A		210 x 365
2000A		260 x 410	2000A		225 x 380
2500A		280 x 440	2500A		245 x 400

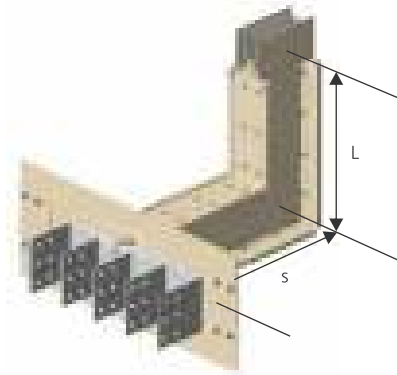

Aluminium Busduct			Copper Busduct		
Ampere (A)	Standard Length (mm) S x L	Minimum Length (mm) S x L	Ampere (A)	Standard Length (mm) S x L	Minimum Length (mm) S x L
3200A	700 x 700	330 x 480	3200A	700 x 700	285 x 435
4000A		380 x 530	4000A		320 x 470
-	-	-	5000A		355 x 505

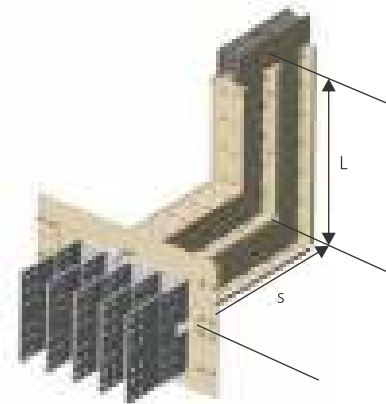

Aluminium Busduct			Copper Busduct		
Ampere (A)	Standard Length (mm) S x L	Minimum Length (mm) S x L	Ampere (A)	Standard Length (mm) S x L	Minimum Length (mm) S x L
5000A	700 x 700	500 x 650	-	-	-
6300A	750 x 750	650 x 725	6300A	700 x 700	440x 590

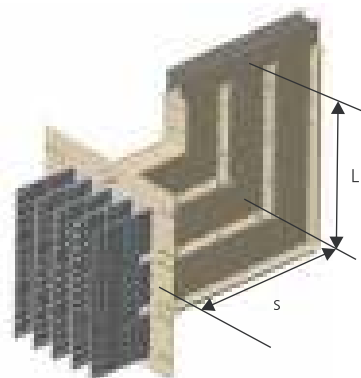

# System Components

## Horizontal Elbow with Flanged End

The combined horizontal elbow and flanged end is used when standard dimensions of either cannot be individually used.

Aluminium Busduct			Copper Busduct		
Ampere (A)	Standard Length (mm) S x L	Minimum Length (mm) S x L	Ampere (A)	Standard Length (mm) S x L	Minimum Length (mm) S x L
250A	500 x 500	350 x 300	-	500 x 500	350 x 300
400A			400A		
630A			630A		
800A			800A		
1000A			1000A		
1250A			1250A		
1600A			1600A		
2000A			2000A		
2500A			2500A		

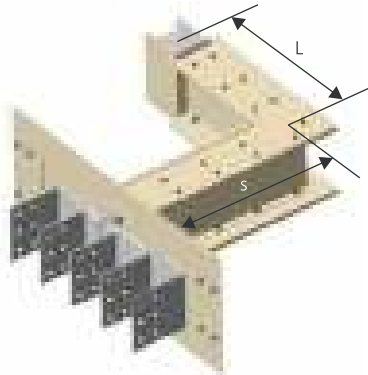

Aluminium Busduct			Copper Busduct		
Ampere (A)	Standard Length (mm) S x L	Minimum Length (mm) S x L	Ampere (A)	Standard Length (mm) S x L	Minimum Length (mm) S x L
3200A	500 x 500	350 x 300	3200A	500 x 500	350 x 300
4000A			4000A		
-			5000A		

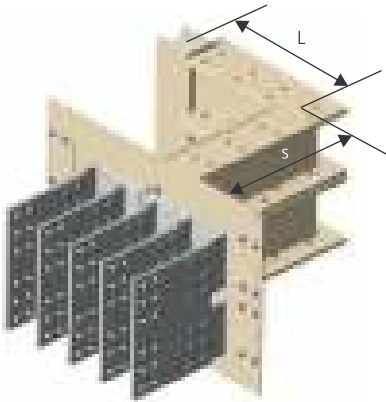

Aluminium Busduct			Copper Busduct		
Ampere (A)	Standard Length (mm) S x L	Minimum Length (mm) S x L	Ampere (A)	Standard Length (mm) S x L	Minimum Length (mm) S x L
5000A	500 x 500	350 x 300	-	-	-
6300A			6300A	500 x 500	350 x 300

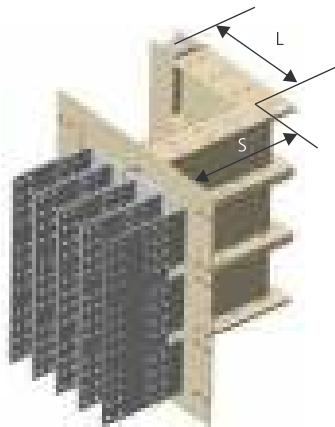

# System Components

## Vertical Offset Elbow with Flanged End

The combined vertical offset elbow and flanged end is used when standard dimensions of either cannot be individually used.

Aluminium Busduct			Copper Busduct		
Ampere (A)	Standard Length (mm) S x C x L	Minimum Length (mm) S x C x L	Ampere (A)	Standard Length (mm) S x C x L	Minimum Length (mm) S x C x L
250A	500 x 500 x 500	180 x 280 x 325	-	500 x 500 x 500	-
400A		180 x 280 x 330	400A		175 x 275 x 330
630A		180 x 280 x 340	630A		175 x 275 x 330
800A		190 x 290 x 350	800A		180 x 280 x 335
1000A		210 x 310 x 360	1000A		185 x 285 x 340
1250A		220 x 320 x 370	1250A		195 x 295 x 350
1600A		230 x 330 x 390	1600A		210 x 310 x 365
2000A		260 x 360 x 410	2000A		225 x 325 x 380
2500A		280 x 380 x 440	2500A		245 x 345 x 400

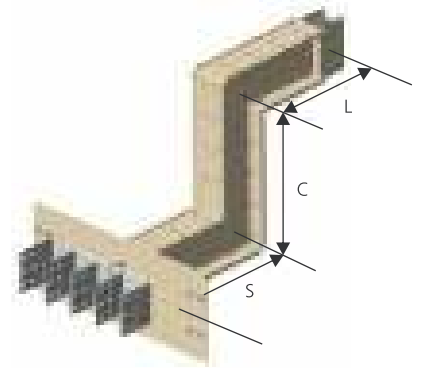

Aluminium Busduct			Copper Busduct		
Ampere (A)	Standard Length (mm) S x C x L	Minimum Length (mm) S x C x L	Ampere (A)	Standard Length (mm) S x C x L	Minimum Length (mm) S x C x L
3200A	750 x 750 x 750	330 x 330 x 480	3200A	750 x 750 x 750	285 x 285 x 435
4000A		380 x 380 x 530	4000A		320 x 320 x 470
-		-	5000A		355 x 355 x 505

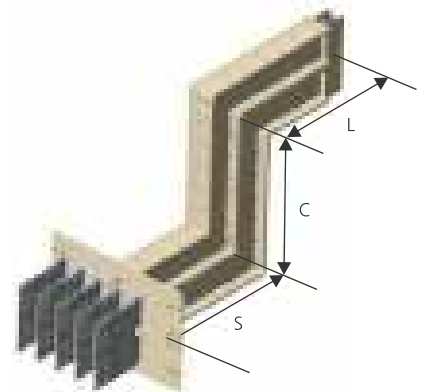

Aluminium Busduct			Copper Busduct		
Ampere (A)	Standard Length (mm) S x C x L	Minimum Length (mm) S x C x L	Ampere (A)	Standard Length (mm) S x C x L	Minimum Length (mm) S x C x L
5000A	750 x 750 x 750	500 x 500 x 650	-	-	-
6300A		650 x 650 x 725	6300A	750 x 750 x 750	440 x 440 x 590

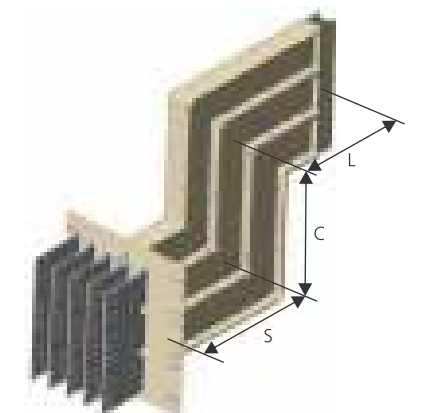

# System Components

## Horizontal Offset Elbow with Flanged End

The combined horizontal offset elbow and flanged end is used when standard dimensions of either cannot be individually used.

Aluminium Busduct			Copper Busduct		
Ampere (A)	Standard Length (mm) S x C x L	Minimum Length (mm) S x C x L	Ampere (A)	Standard Length (mm) S x C x L	Minimum Length (mm) S x C x L
250A	500 x 500 x 500	350 x 350 x 300	-	500 x 500 x 500	350 x 350 x 300
400A			400A		
630A			630A		
800A			800A		
1000A			1000A		
1250A			1250A		
1600A			1600A		
2000A			2000A		
2500A			2500A		

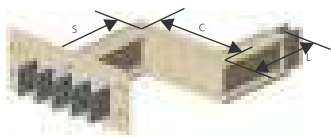

Aluminium Busduct			Copper Busduct		
Ampere (A)	Standard Length (mm) S x C x L	Minimum Length (mm) S x C x L	Ampere (A)	Standard Length (mm) S x C x L	Minimum Length (mm) S x C x L
3200A	500 x 500 x 500	350 x 350 x 300	3200A	500 x 500 x 500	350 x 350 x 300
4000A			4000A		
-			5000A		

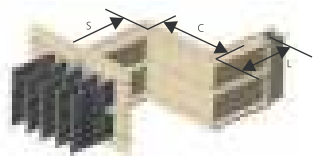

Aluminium Busduct			Copper Busduct		
Ampere (A)	Standard Length (mm) S x C x L	Minimum Length (mm) S x C x L	Ampere (A)	Standard Length (mm) S x C x L	Minimum Length (mm) S x C x L
5000A	500 x 500 x 500	350 x 350 x 300	-	-	-
6300A			500 x 500 x 500	350 x 350 x 300	

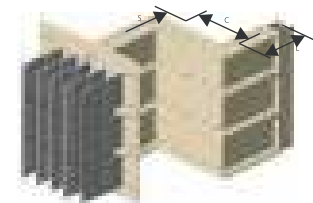

# System Components

## Combination Elbow with Flanged End

The combined combination elbow and flanged end is used when standard dimensions of either cannot be individually used.

Aluminium Busduct			Copper Busduct		
Ampere (A)	Standard Length (mm) S x C x L	Minimum Length (mm) S x C x L	Ampere (A)	Standard Length (mm) S x C x L	Minimum Length (mm) S x C x L
250A	500 x 500 x 500	180 x 325 x 300	-	500 x 500 x 500	-
400A		180 x 330 x 300	400A		175 x 330 x 300
630A		180 x 340 x 300	630A		175 x 330 x 300
800A		190 x 350 x 300	800A		180 x 335 x 300
1000A		210 x 360 x 300	1000A		185 x 340 x 300
1250A		220 x 370 x 300	1250A		195 x 350 x 300
1600A		230 x 390 x 300	1600A		210 x 365 x 300
2000A		260 x 410 x 300	2000A		225 x 380 x 300
2500A		280 x 440 x 300	2500A		245 x 400 x 300

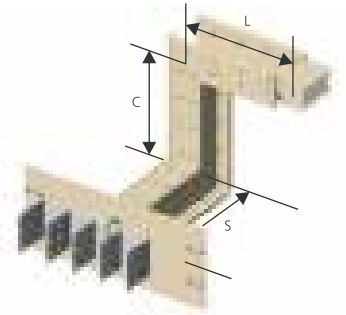

Aluminium Busduct			Copper Busduct		
Ampere (A)	Standard Length (mm) S x C x L	Minimum Length (mm) S x C x L	Ampere (A)	Standard Length (mm) S x C x L	Minimum Length (mm) S x C x L
3200A	700 x 700 x 700	330 x 480 x 300	3200A	700 x 700 x 700	285 x 435 x 300
4000A		380 x 530 x 300	4000A		320 x 470 x 300
-		-	5000A		355 x 505 x 300

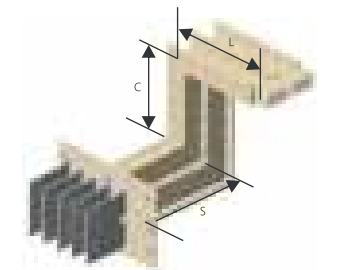

Aluminium Busduct			Copper Busduct		
Ampere (A)	Standard Length (mm) S x C x L	Minimum Length (mm) S x C x L	Ampere (A)	Standard Length (mm) S x C x L	Minimum Length (mm) S x C x L
5000A	700 x 700 x 700	500 x 650 x 300	-	-	-
6300A	750 x 750 x 500	650 x 725 x 300	6300A	700 x 700 x 700	440 x 590 x 300

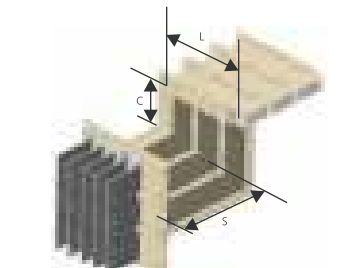

# System Components

## Compact Expansion Joint

Expansion Joint is used in the system to accommodate the expansion and contraction of busbars happens due to heat by current loading and the ambient temperature.

Aluminium Busduct					
Ampere (A)	W (mm)			H (mm)	L (mm)
	3P3W+50%E	3P4W+50%E	3P5W+50%E		
250				340	1500
400				350	
630				370	
800				390	
1000				410	
1250				435	
1600	391	441	491	460	
2000				510	
2500				560	
3200				650	
4000				750	
5000				990	
6300				1140	

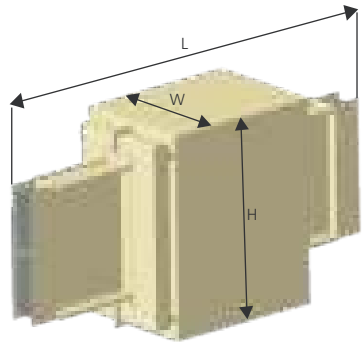
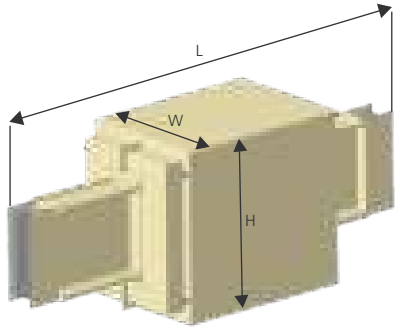

Copper Busduct					
Ampere (A)	W (mm)			H (mm)	L (mm)
	3P3W+50%E	3P4W+50%E	3P5W+50%E		
400				368	1500
630				368	
800				378	
1000				383	
1250				403	
1600				430	
2000	391	441	491	468	
2500				503	
3200				570	
4000				646	
5000				716	
6300				884	

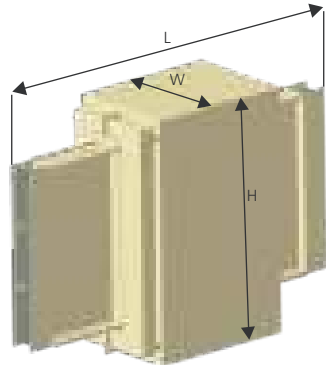

- Note:
1. It is recommended to use expansion joint in the route when any Busduct installation is crossing the building expansion joint to accommodate Busduct's Enclosure's physical movement

# System Components

## Necessity of Expansion

The busduct expands and contracts due to the heat by current loading and the ambient temperature. The elongation of the busduct is approximately  $1.8 \times 10^{-2} \text{mm/m/}^\circ\text{C}$ . For example, when the ambient temperature is  $30^\circ\text{C}$  and the temperature rise of busduct is  $40^\circ\text{C}$ , we have the below result of elongation for the busduct as follows.

$$1.8 \times 10^{-2} \times (30 + 40) = 1.26 \text{mm/m}$$

Moreover, there is a substance in respect to the busduct elongation by temperature rise, where the difference in the elongation between the conductor and the housing will result from a difference in their coefficients of expansion and temperature.

\* This fitting is designed to absorb 25mm longitudinal expansion

Note:

1. For horizontal run, it is recommended that an expansion joint be installed every 40 metres.
2. For vertical run, please refer to the chart below.

Supporting Condition	Branching	Fig.	Length (L) which needs no expansion unit
Both ends free	Branched at each storey	1	120 (m)
One end free	Branched at each storey	2	90 (m)
One end fixed	Not branched	3	60 (m)
Both ends fixed	Branched at each storey	4	60 (m)

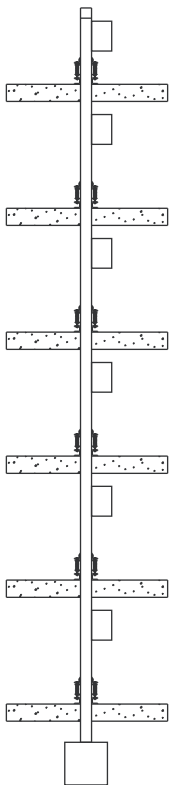

Fig. 1.  $L \leq 120\text{m}$

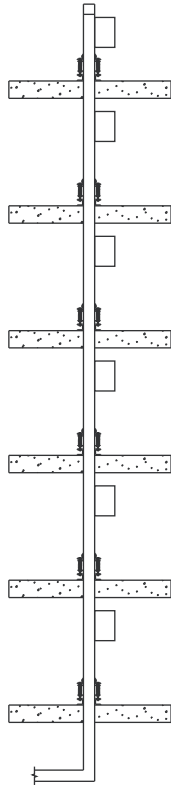

Fig. 2.  $L \leq 90\text{m}$

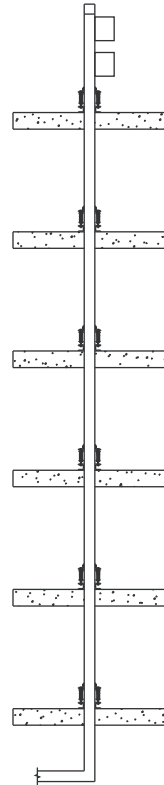

Fig. 3.  $L \leq 60\text{m}$

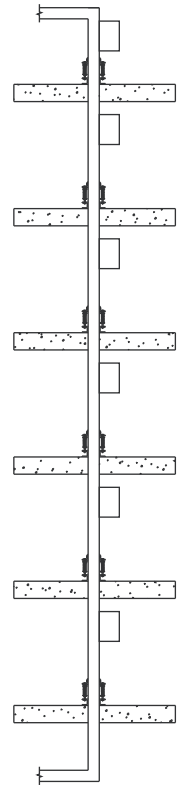

Fig. 4.  $L \leq 60\text{m}$

Note:

1. Expansion joints are used in the case of installation deviating from the above condition.
2. Expansion joints are designed and come in between the vertical hangers.

# System Components

## Plug-in Box with Mechanical Interlocking

Introducing new Plug-in Box with Mechanical interlocking.

Plug-in boxes are designed with Busbar & Door interlocks, it also give features for ease of handling & safety.

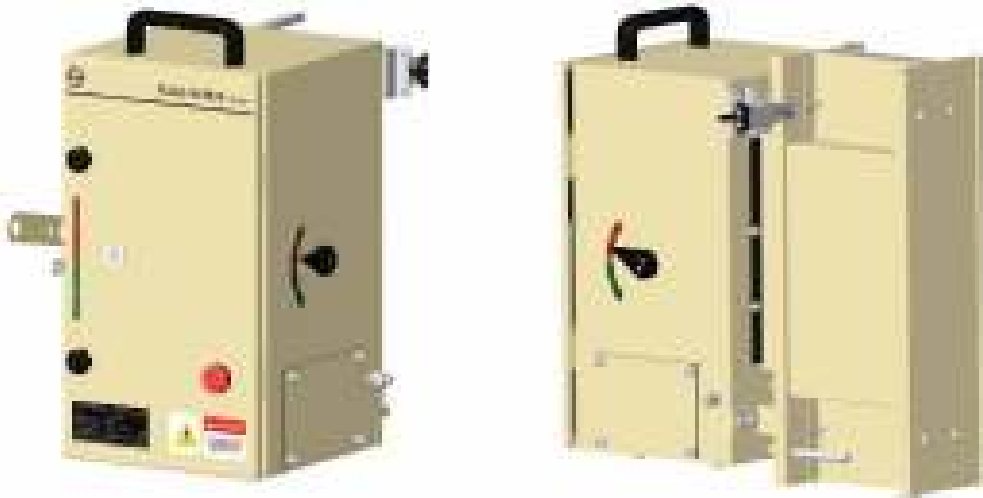

Frame Size	Rating	W	D	H
Frame -1	16A to 100A	230	236	415.5
Frame -2	125A to 250A	250	251	512
Frame -3	250A to 400A	300	257	600

- Plug-in box can be equipped with MCCB
- Plug-in boxes are suitable for copper cable termination
- For Aluminium cable termination, required separate cable entry box (refer clause no. 13 of installation guidelines)

## Busbar Interlock

- Plug-in Box can't be removed from Busduct when MCCB in ON
- MCCB can't be switched ON even when Plug-in Box is mounted on Busduct; it is possible only if interlock plate is engaged with feeder

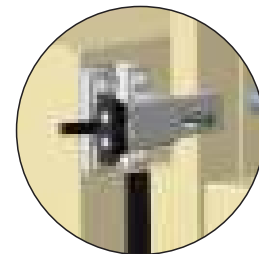

## Door Interlocks

- Door can't be opened when MCCB is ON
- MCCB can't be switched ON until door is completely closed
- Door defeat feature available to use in case of emergency

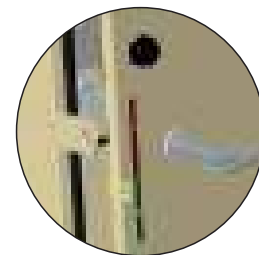

# System Components

## Ease of Handling & Installation

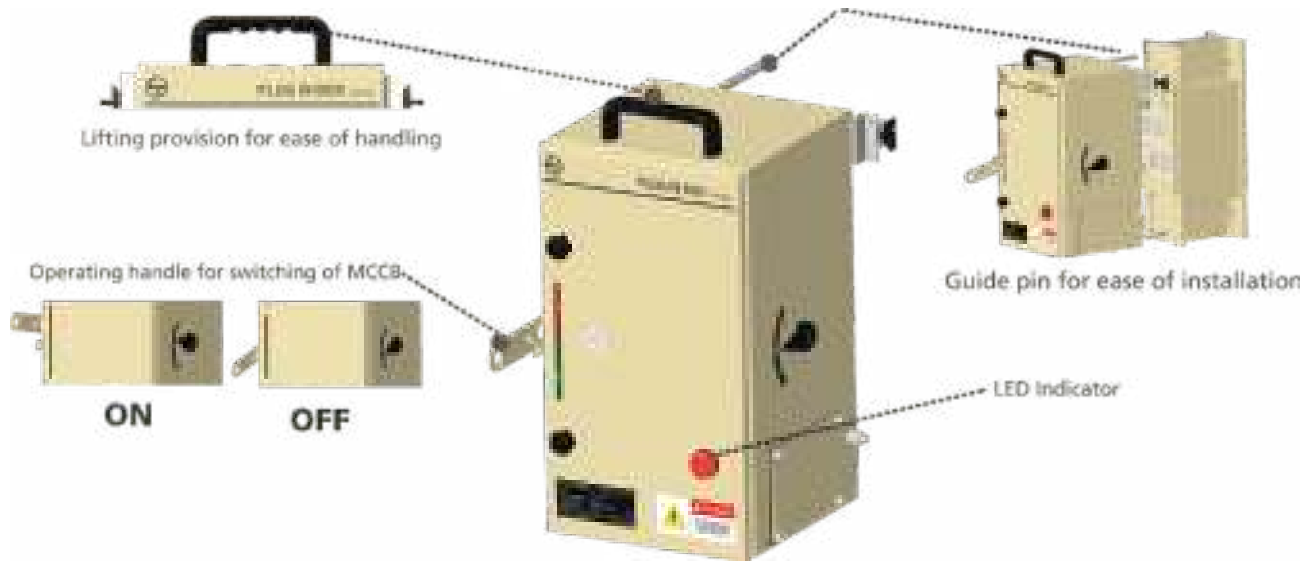

## Earth Terminal

- Earth contact of Plug-in box makes contact with Earth bar of Busduct before Phase conductors of Plug-in box & Busduct comes in contact
- In case of emergency, Plug-in box can be mounted on live Busduct
- In case of without internal earth configuration; Plug-in box can be earthed with external earth conductor

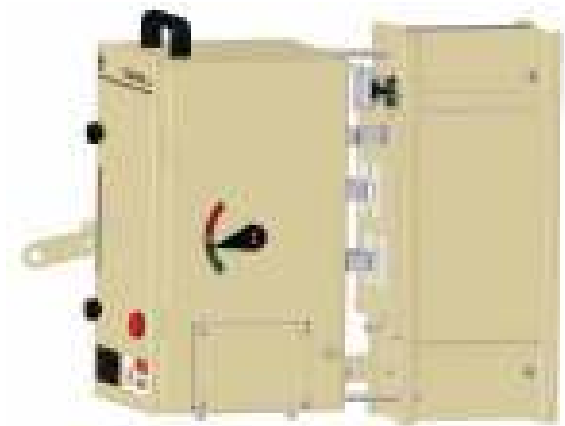

## Padlock Provision

- Can be used in OFF position of MCCB
- Ensure human safety during maintenance work

# System Components

## Plug-in Box with Rotary Operating Mechanism

- Plug-in box can be equipped with MCCB, MCB
- With door interlock using ROM
- Earth contact of plug-in box 'makes first and breaks last'
- Gland plates provided on bottom and both sides of the box for cable entry
- Plug-in boxes are suitable for copper cable termination
- For Aluminum cable termination required separate cable entry box (refer clause no-13 of installation Guidelines)

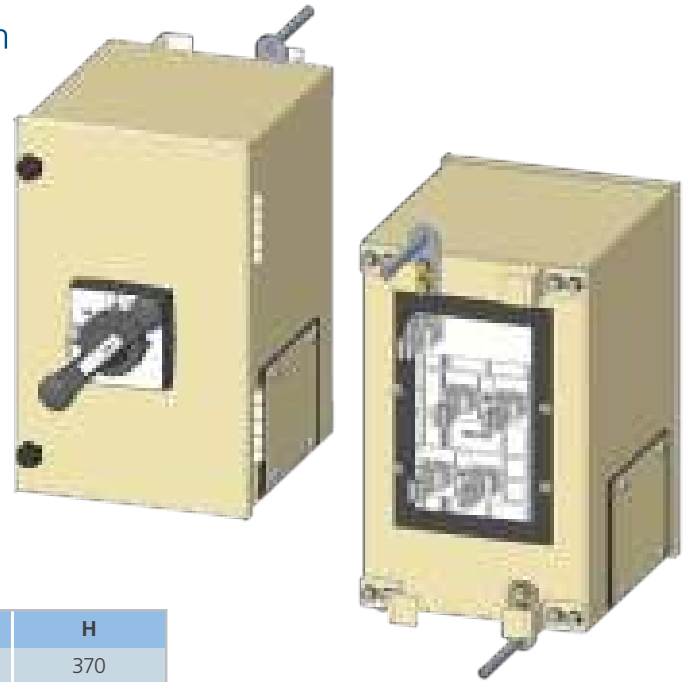

Frame size	Rating	W	D	H
Frame - 1	16A to 100A	230	250	370
Frame - 2	125A to 250A	250	270	450
Frame - 3	250A to 400A	300	300	540
Frame - 4	500A to 630A	370	338	805

New

## New Plug-in Box with Switch Disconnecter Fuse

- Plug-In Box available with Door interlock feature
- Earth contact of plug-In box "makes first and breaks last"
- Bottom and side Gland plates for cable entry
- Guide Pin for plug-in box mounting
- Suitable for Copper cable termination

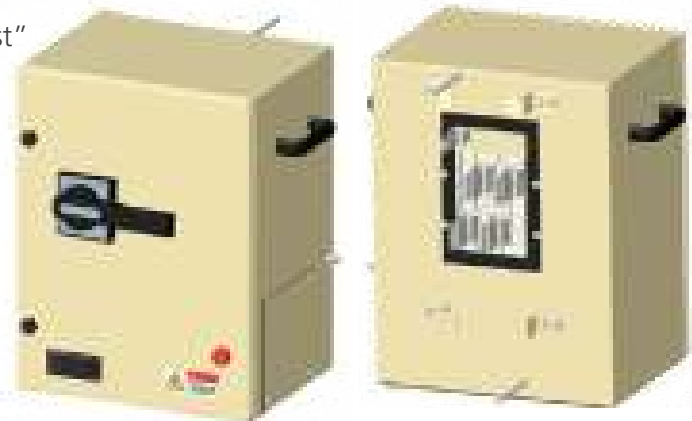

Frame size	Rating	W	D	H
Frame - 0	32A to 63A	260	237	415.5
Frame - 1	100A to 160A	355	267	415.5
Frame - 2	200A to 250A	390	303	512
Frame - 3	315A to 400A	440	363	600

# System Components

## Tap-off Box

- The tap-off box is provided with fixed contacts from the busduct
- The tap-off box can be equipped with MCCB
- With door interlock using ROM
- The tap-off box enclosure is made of G. I.
- Gland plates are provided on the bottom and on both sides of the box for cable entry
- Tap-off boxes are suitable for copper cable termination



Frame - 2	W	D	H
125A to 250A	385	250	620

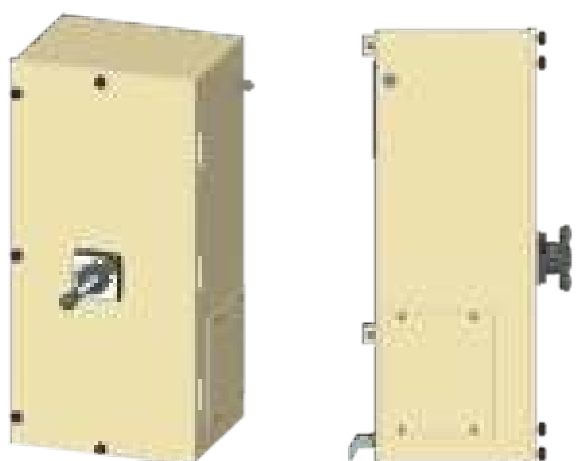

Frame - 3	W	D	H
300A to 630A	400	310	840



Frame - 4	W	D	H
800A to 1250A	450	400	1000

# System Components

## Joint Block Assembly

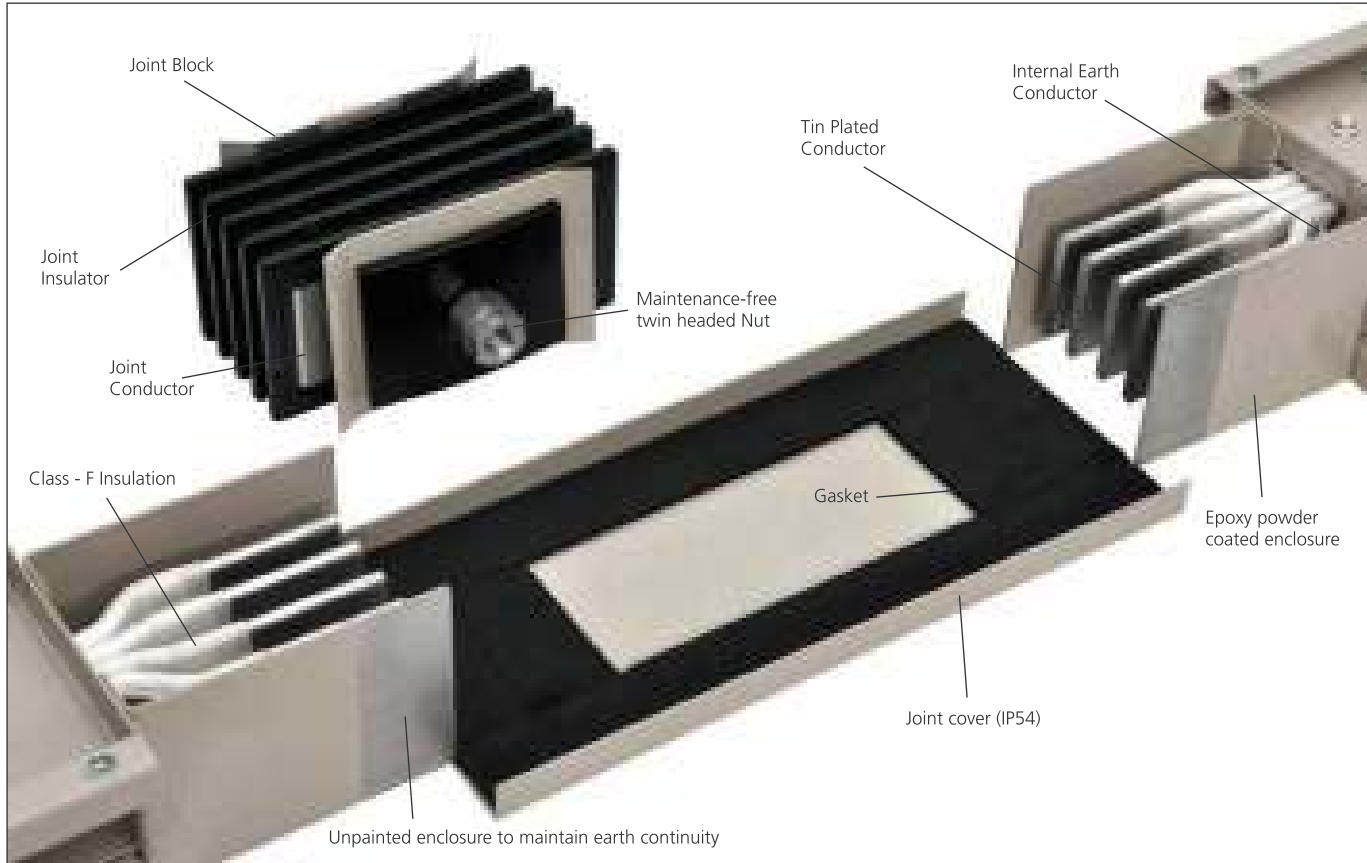

## Joint Connection Process



# System Components

## Details of Flanged End Support Plate for Aluminum & Copper Busduct

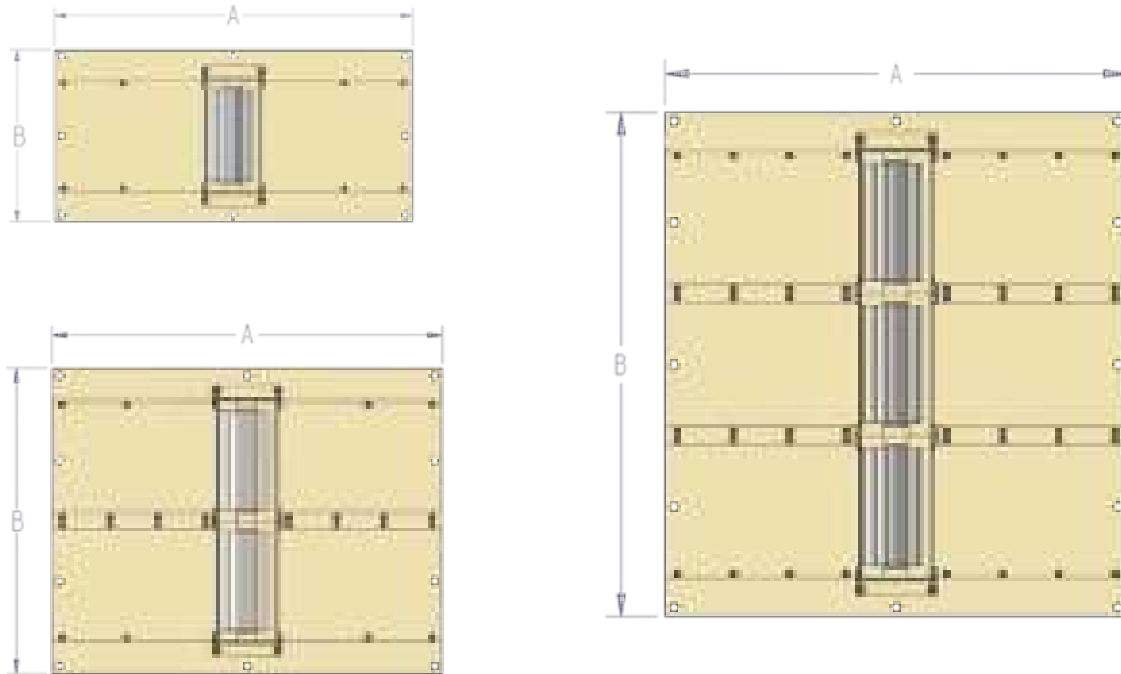

Note:

A: Support plate length

B: Support plate width depending on current rating

### End Termination Pitch: 110mm

Aluminium Busduct (A)	Stack	Copper Busduct (A)	Stack	3P3W	3P3W+50%E	3P4W	3P4W+50%E	3P5W	3P5W+50%E	Aluminium Busduct	Copper Busduct
				A	A	A	A	A	A	B	B
250A	1	-	-	370	550	460	650	550	760	200	-
400A	1	400A	1	370	550	460	650	550	760	210	210
630A	1	630A	1	370	550	460	650	550	760	230	210
800A	1	800A	1	370	550	460	650	550	760	250	220
1000A	1	1000A	1	370	550	460	650	550	760	270	225
1250A	1	1250A	1	370	550	460	650	550	760	295	245
1600A	1	1600A	1	370	550	460	650	550	760	320	272
2000A	1	2000A	1	370	550	460	650	550	760	370	310
2500A	1	2500A	1	370	550	460	650	550	760	420	345
3200A	2	3200A	2	370	550	460	650	550	760	510	412
4000A	2	4000A	2	370	550	460	650	550	760	610	488
5000A	3	5000A	2	370	550	460	650	550	760	850	558
6300A	3	6300A	3	370	560	460	650	560	760	1000	726

# System Components

## End Termination Pitch: 130mm

Aluminium Busduct (A)	Stack	Copper Busduct (A)	Stack	3P3W	3P3W+50%E	3P4W	3P4W+50%E	3P5W	3P5W+50%E	Aluminium Busduct	Copper Busduct
				A	A	A	A	A	A	B	B
250A	1	-	-	370	650	510	760	650	910	200	-
400A	1	400A	1	370	650	510	760	650	910	210	210
630A	1	630A	1	370	650	510	760	650	910	230	210
800A	1	800A	1	370	650	510	760	650	910	250	220
1000A	1	1000A	1	370	650	510	760	650	910	270	225
1250A	1	1250A	1	370	650	510	760	650	910	295	245
1600A	1	1600A	1	370	650	510	760	650	910	320	272
2000A	1	2000A	1	370	650	510	760	650	910	370	310
2500A	1	2500A	1	370	650	510	760	650	910	420	345
3200A	2	3200A	2	370	650	510	760	650	910	510	412
4000A	2	4000A	2	370	650	510	760	650	910	610	488
5000A	3	5000A	2	370	650	510	760	650	910	850	558
6300A	3	6300A	3	370	650	510	760	650	910	1000	726

## End Termination Pitch: 150mm

Aluminium Busduct (A)	Stack	Copper Busduct (A)	Stack	3P3W	3P3W+50%E	3P4W	3P4W+50%E	3P5W	3P5W+50%E	Aluminium Busduct	Copper Busduct
				A	A	A	A	A	A	B	B
250A	1	-	-	460	710	560	850	710	1000	200	-
400A	1	400A	1	460	710	560	850	710	1000	210	210
630A	1	630A	1	460	710	560	850	710	1000	230	210
800A	1	800A	1	460	710	560	850	710	1000	250	220
1000A	1	1000A	1	460	710	560	850	710	1000	270	225
1250A	1	1250A	1	460	710	560	850	710	1000	295	245
1600A	1	1600A	1	460	710	560	850	710	1000	320	272
2000A	1	2000A	1	460	710	560	850	710	1000	370	310
2500A	1	2500A	1	460	710	560	850	710	1000	420	345
3200A	2	3200A	2	460	710	560	850	710	1000	510	412
4000A	2	4000A	2	460	710	560	850	710	1000	610	488
5000A	3	5000A	2	460	710	560	850	710	1000	850	558
6300A	3	6300A	3	460	710	560	850	710	1000	1000	726

# System Components

## End Termination Pitch: 175mm

Aluminium Busduct (A)	Stack	Copper Busduct (A)	Stack	3P3W	3P3W+50%E	3P4W	3P4W+50%E	3P5W	3P5W+50%E	Aluminium Busduct	Copper Busduct
				A	A	A	A	A	A	B	B
250A	1	-	-	460	810	650	1000	810	1150	200	-
400A	1	400A	1	460	810	650	1000	810	1150	210	210
630A	1	630A	1	460	810	650	1000	810	1150	230	210
800A	1	800A	1	460	810	650	1000	810	1150	250	220
1000A	1	1000A	1	460	810	650	1000	810	1150	270	225
1250A	1	1250A	1	460	810	650	1000	810	1150	295	245
1600A	1	1600A	1	460	810	650	1000	810	1150	320	272
2000A	1	2000A	1	460	810	650	1000	810	1150	370	310
2500A	1	2500A	1	460	810	650	1000	810	1150	420	345
3200A	2	3200A	2	460	810	650	1000	810	1150	510	412
4000A	2	4000A	2	460	810	650	1000	810	1150	610	488
5000A	3	5000A	2	460	810	650	1000	810	1150	850	558
6300A	3	6300A	3	460	810	650	1000	810	1150	1000	726

## End Termination Pitch: 200mm

Aluminium Busduct (A)	Stack	Copper Busduct (A)	Stack	3P3W	3P3W+50%E	3P4W	3P4W+50%E	3P5W	3P5W+50%E	Aluminium Busduct	Copper Busduct
				A	A	A	A	A	A	B	B
250A	1	-	-	510	910	710	1100	910	1300	200	-
400A	1	400A	1	510	910	710	1100	910	1300	210	210
630A	1	630A	1	510	910	710	1100	910	1300	230	210
800A	1	800A	1	510	910	710	1100	910	1300	250	220
1000A	1	1000A	1	510	910	710	1100	910	1300	270	225
1250A	1	1250A	1	510	910	710	1100	910	1300	295	245
1600A	1	1600A	1	510	910	710	1100	910	1300	320	272
2000A	1	2000A	1	510	910	710	1100	910	1300	370	310
2500A	1	2500A	1	510	910	710	1100	910	1300	420	345
3200A	2	3200A	2	510	910	710	1100	910	1300	510	412
4000A	2	4000A	2	510	910	710	1100	910	1300	610	488
5000A	3	5000A	2	510	910	710	1100	910	1300	850	558
6300A	3	6300A	3	510	910	710	1100	910	1300	1000	726

# System Components

## Details of End Termination

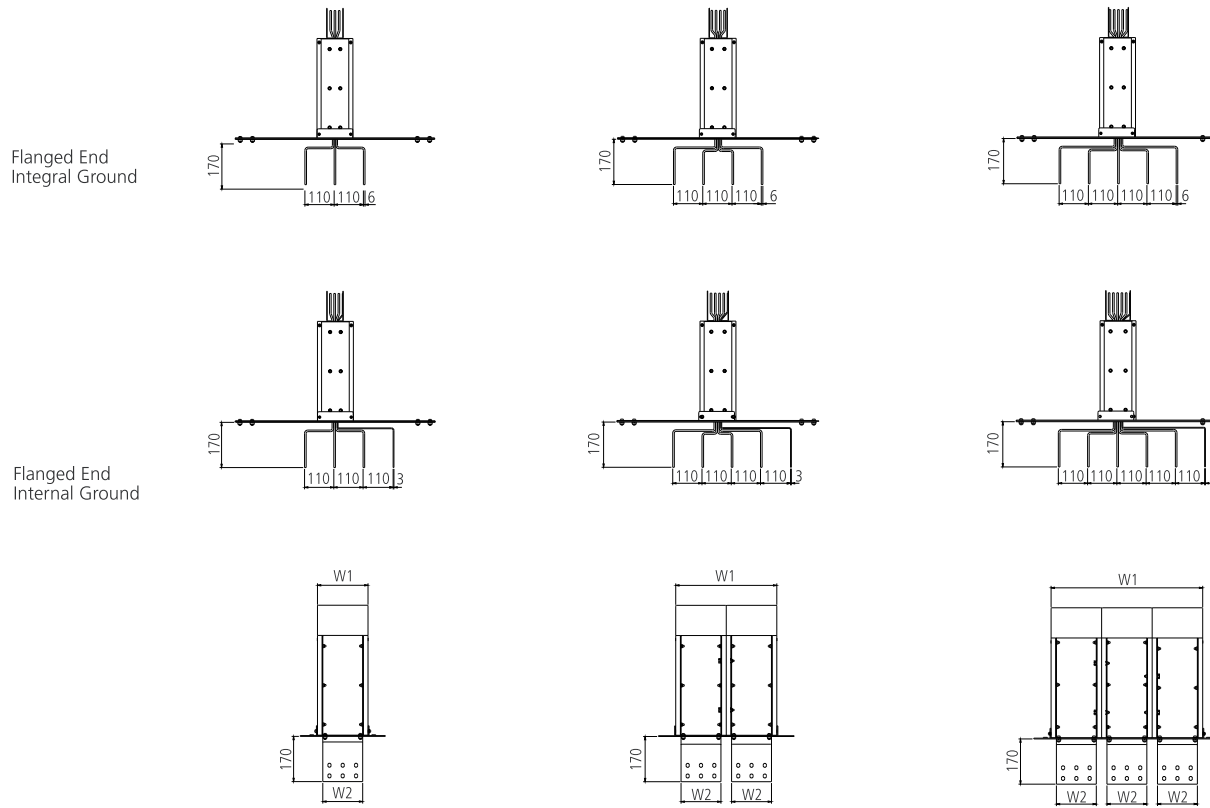

Busbar Hole Pattern

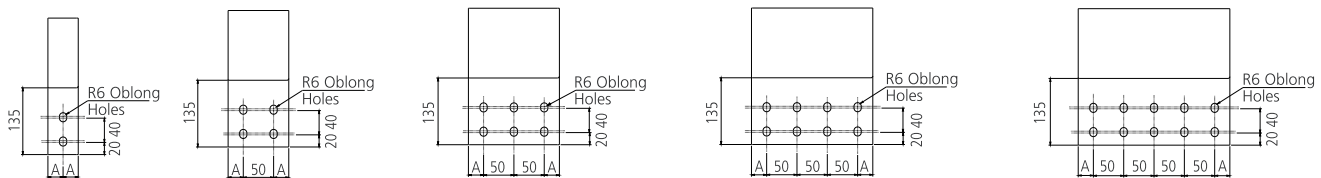

Ampere (A)	Aluminium Busduct Dimensions (mm)		Copper Busduct Dimensions (mm)	
	W1	W2	W1	W2
250A	70	30x1	-	-
400A	80	40x1	78	40x1
630A	95	60x1	78	40x1
800A	115	80x1	88	50x1
1000A	140	100x1	93	55x1
1250A	165	125x1	113	75x1
1600A	190	150x1	140	102x1
2000A	240	200x1	178	140x1
2500A	290	250x1	213	175x1
3200A	380	150x2	280	102x2
4000A	480	200x2	356	140x2
5000A	720	200x3	426	175x2
6300A	870	250x3	594	160x3

# System Components

## Horizontal Supports

Vertical Orientation

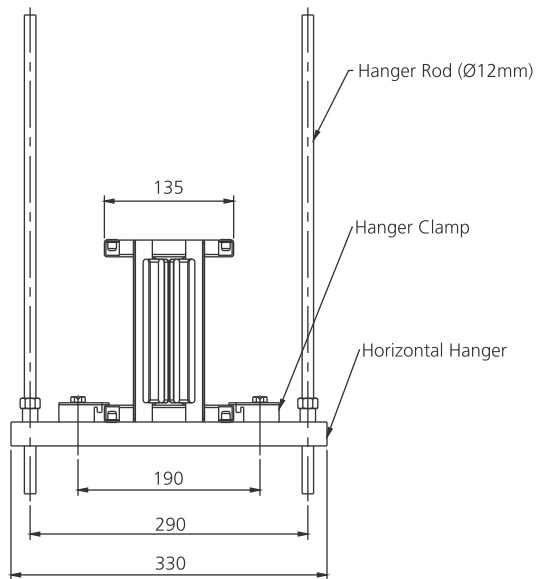

Horizontal Orientation

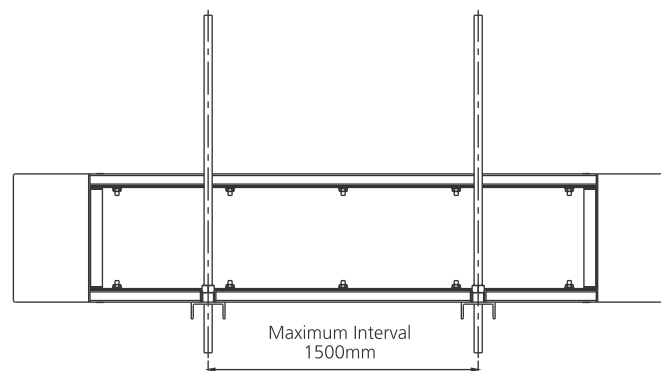
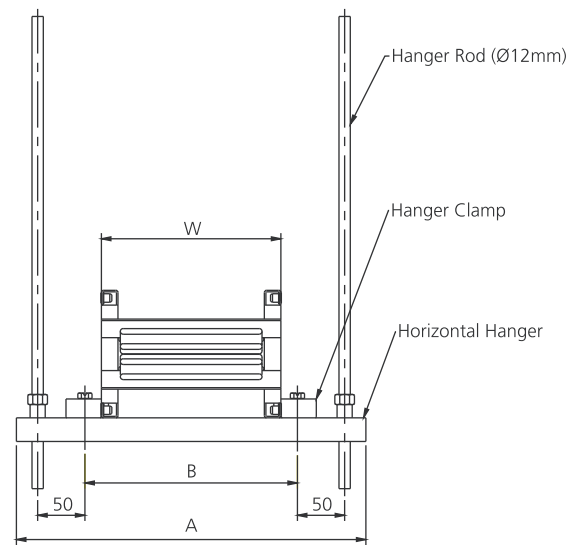

Aluminium Busduct (A)	Stack	Dimensions (mm)			Copper Busduct (A)	Stack	Dimensions (mm)		
		W	A	B			W	A	B
250A	1	70	250	105	-	-	-	-	-
400A	1	80	260	115	400A	1	78	258	106
630A	1	100	280	135	630A	1	78	258	106
800A	1	120	300	155	800A	1	88	268	116
1000A	1	140	320	175	1000A	1	93	273	121
1250A	1	165	345	200	1250A	1	113	293	141
1600A	1	190	370	225	1600A	1	140	320	168
2000A	1	240	420	275	2000A	1	178	358	206
2500A	1	290	470	325	2500A	1	213	393	241
3200A	2	380	560	415	3200A	2	280	460	308
4000A	2	480	660	515	4000A	2	356	536	384
5000A	3	720	900	755	5000A	2	426	606	454
6300A	3	870	1050	905	6300A	3	594	774	622

# System Components

## Vertical Supports

### Vertical Fix Hanger

### Vertical Spring Hanger

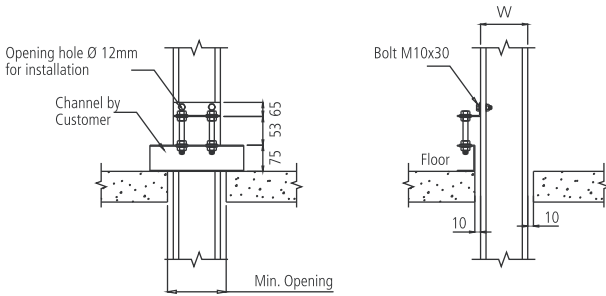

Fig 1.1

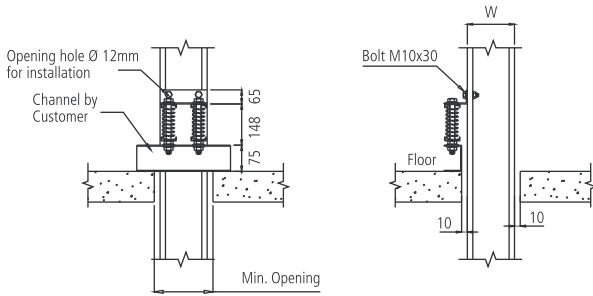

Fig 1.2

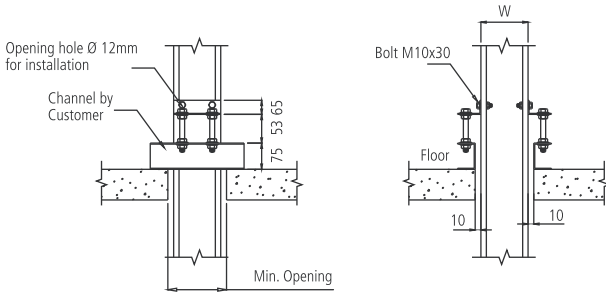

Fig 2.1

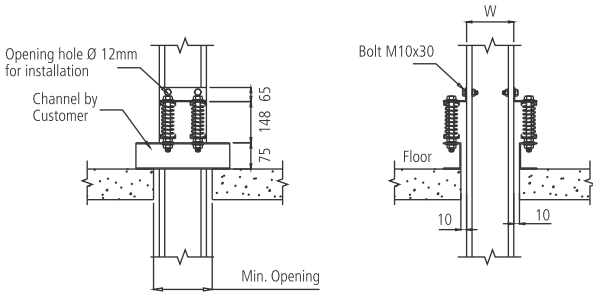

Fig 2.2

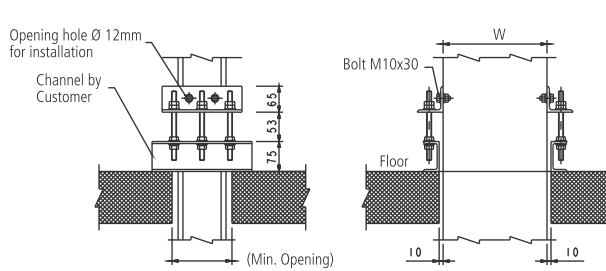

Fig 3.1

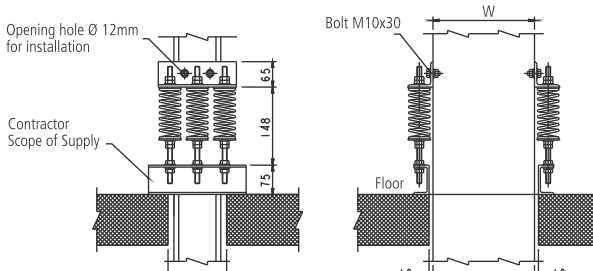

Fig 3.2

Figure No	Aluminium Busduct	Copper Busduct
Fig 1.1 & Fig 1.2	250A to 1600A	400A to 1250A
Fig 2.1 & Fig 2.2	2000A to 6300A	1600A to 4000A
Fig 3.1 & Fig 3.2	-	5000A to 6300A

# System Components

## Wall Flange / Floor Flange

Aluminium Busduct (A)	Dimensions (mm)		Copper Busduct (A)	Dimensions (mm)	
	W (mm)	A (mm)		W (mm)	A (mm)
250A	70	190	-	-	-
400A	80	200	400	78	198
630A	100	220	630	78	198
800A	120	240	800	88	208
1000A	140	260	1000	93	213
1250A	165	285	1250	113	233
1600A	190	310	1600	140	260
2000A	240	360	2000	178	298
2500A	290	410	2500	213	333
3200A	380	500	3200	280	400
4000A	480	600	4000	356	476
5000A	720	840	5000	426	546
6300A	870	990	6300	594	714

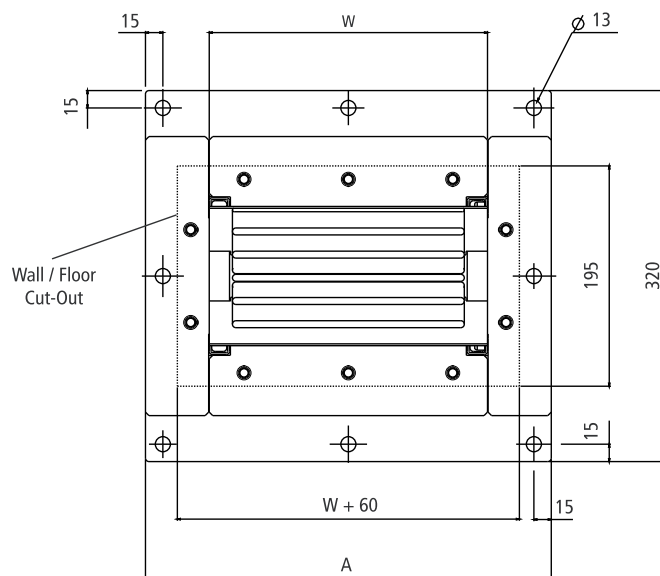

# Termination Guidelines

## General Guidelines

- Ensure that terminal surfaces of Braid, Intermediate Links, BBT terminals, Transformer/Panel terminals are burr free and cleaned with dry cloth before termination.
- Ensure that termination bolt M12 is of class 6.8 and higher, use M12 plain and spring washers both sides of the termination, tightening torque is 50N-m
- Orientation of bolt heads of all phases/neutral is in the same direction.
- It is recommended to use interface barriers of suitable material (Polycarbonate, nylon, Epoxy sheet etc.) in case interface clearance is lower than 40mm.

Termination Guidelines(for Aluminium busduct)									
Current rating(A)	Fig No	W (mm)	A (mm)	No. of holes	No. of braid conductors	Copper braid cross section area(mm2)	Intermediate links (cu) (mm2)	Intermediate links (AL)(mm2)	Equalizer links(AL) (mm2)
250	1	35	17.5	2	1	120	120	250	-
400	1	35	17.5	2	2	240	240	400	-
630	4	80	40	2	1	400	400	640	-
800	3	60	30	2	1	500	500	800	-
1000	2	50	25	2	2	600	600	1000	-
1250	3	60	30	2	2	800	800	1300	-
1600	6	125	37.5	4	2	1000	1000	1600	-
2000	7	150	25	6	2	1500	1500	2400	-
2500	6	125	37.5	4	4	2000	2000	3200	-
3200	8	160	30	6	4	2400	2400	3900	4080
4000	4	80	40	2	8	3200	3200	5200	5280
5000	7	150	25	6	5	4000	4000	6400	8160
6300	7	150	25	6	5	5000	5000	8000	9960

Termination Guidelines(for Copper busduct)								
Current Rating (A)	Fig. No	W (mm)	A (mm)	No. of Holes	No. of braid conductors	Copper braid cross - sec area (mm <sup>2</sup> )	Intermediate Links (Cu) (mm <sup>2</sup> )	Equalizer Links (Cu) (mm <sup>2</sup> )
400	1	35	17.5	2	2	240	240	-
630	3	60	30	2	1	400	400	-
800	3	60	30	2	1	500	500	-
1000	2	50	25	2	2	600	600	-
1250	3	60	30	2	2	800	800	-
1600	6	125	37.5	4	2	1000	1000	-
2000	7	150	25	6	2	1500	1500	-
2500	7	150	25	6	2	2000	2000	-
3200	5	100	25	4	4	2400	2400	3000
4000	7	150	25	6	4	3200	3200	3960
5000	7	150	25	6	4	4000	4000	4800
6300	7	150	25	6	5	5000	5000	6600

# Termination Guidelines

## Flexible Copper Braid Details

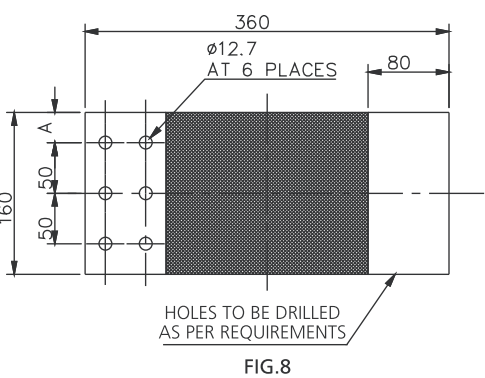
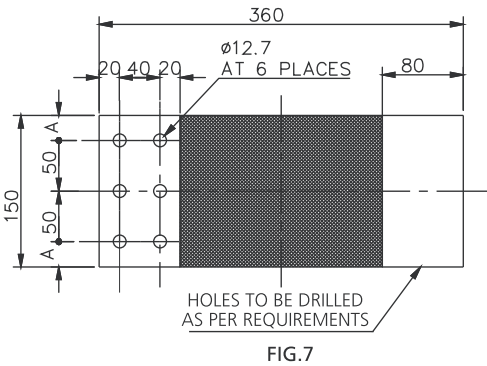
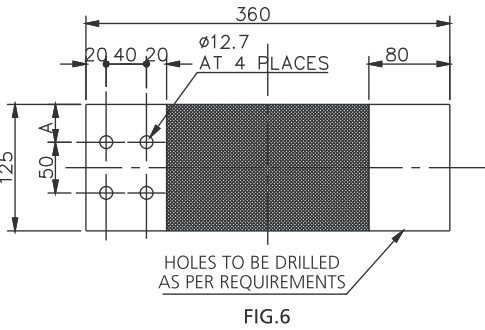
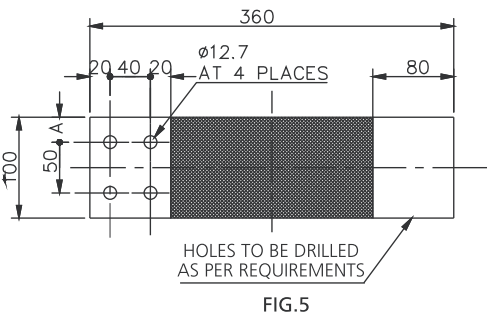
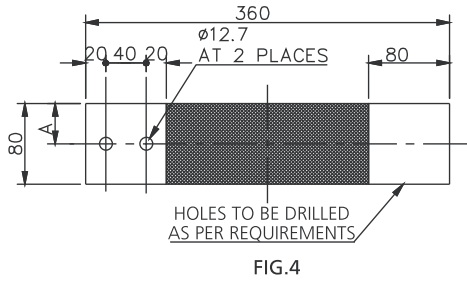
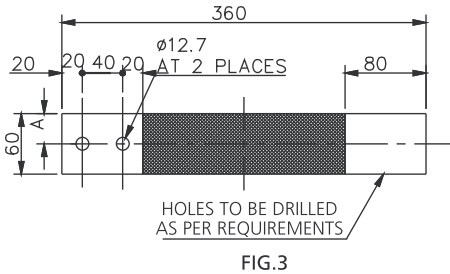
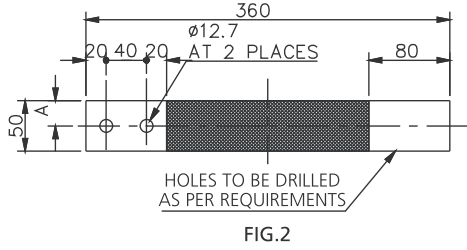
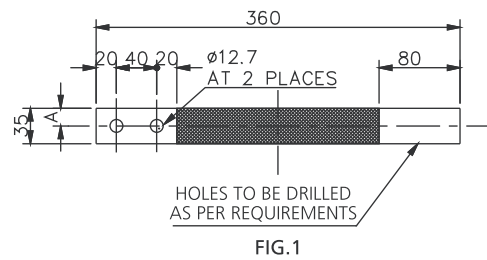

### Braid Material:

Copper Strand: 0.102 mm. diameter (38 SWG) (conforming to IS:4800 part-1)  
 Flat termination: ETP Copper 1/2h; Surface treatment: Tin Plating (12 microns)

# Termination Guidelines

## Single Stack Termination

General arrangement of FE terminal, copper flexible braid, intermediate link, panel/transformer link is shown as below:

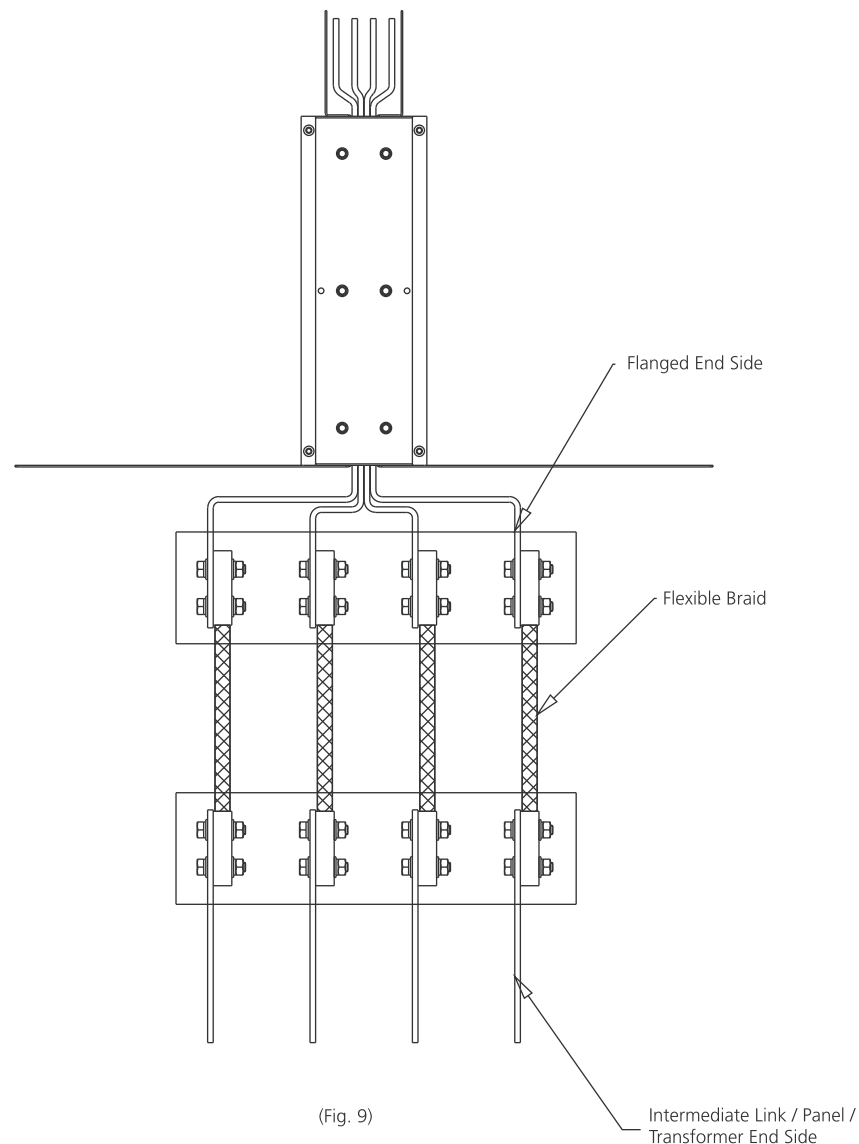

(Fig. 9)

- Select the braid of required cross section and quantity as per the table on page - 50,
- Use the Braid connection to FE side and intermediate link/panel/transformer side as shown in fig. 9/10.
- In case intermediate link is required to be connected between braid and panel/transformer terminal, the material and cross section of intermediate link to be selected as per table on page-50
- Preferred arrange for connecting multiple braids to the FE end/equalizer plate is shown in fig. 11 depending upon no. of braids to be connected.
- Min. phase clearance between phases to be measured as per fig.12

# Termination Guidelines

## Double Stack and Triple Stack Termination

The general arrangement of double and triple stack FE terminals, equaliser plates\*, flexible copper braids, intermediate links and panel/transformer links is shown below.

(\*Equaliser plates are provided by manufacturer for Flange End side termination)

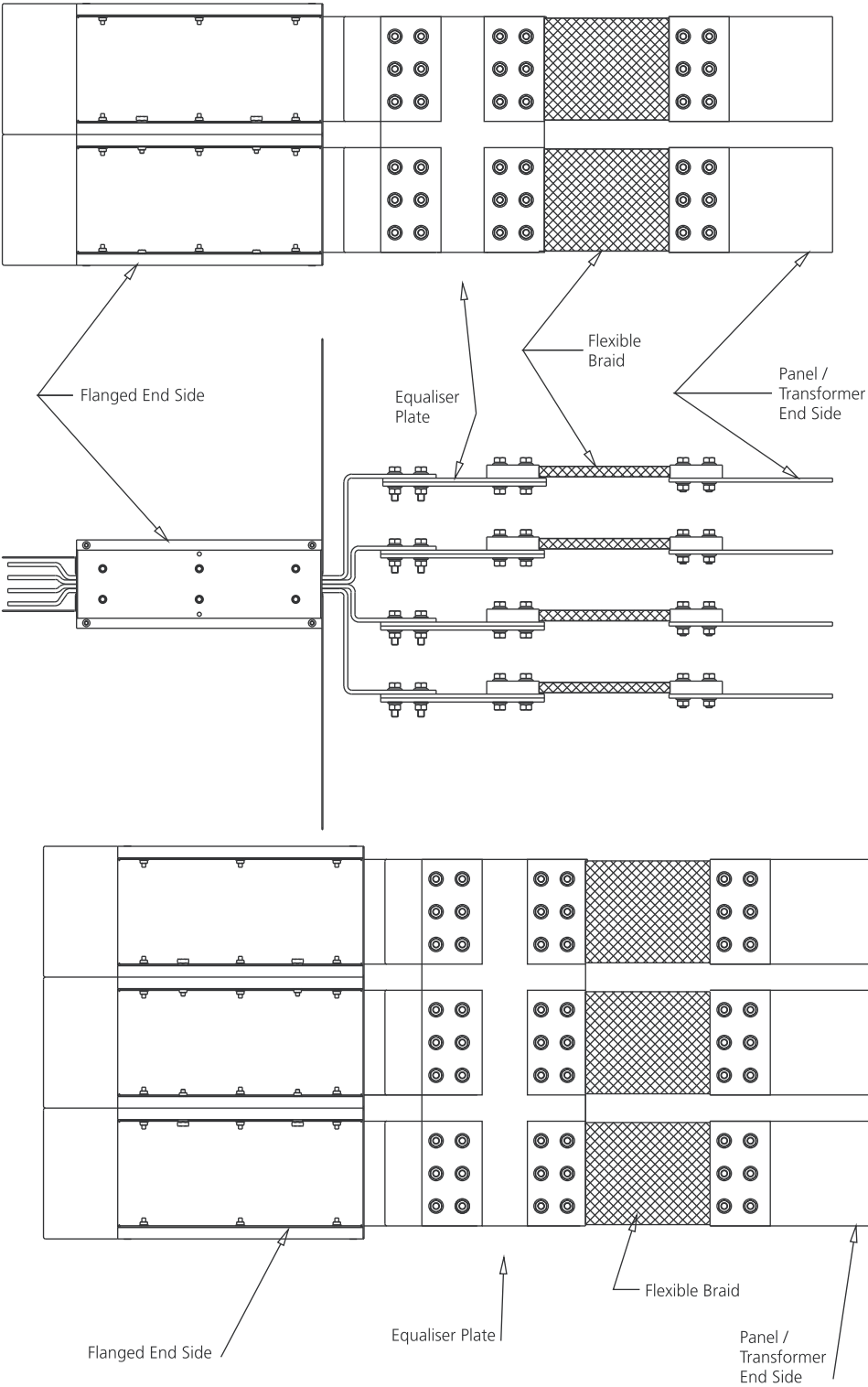

Fig 10

# Termination Guidelines

## Termination Sequence

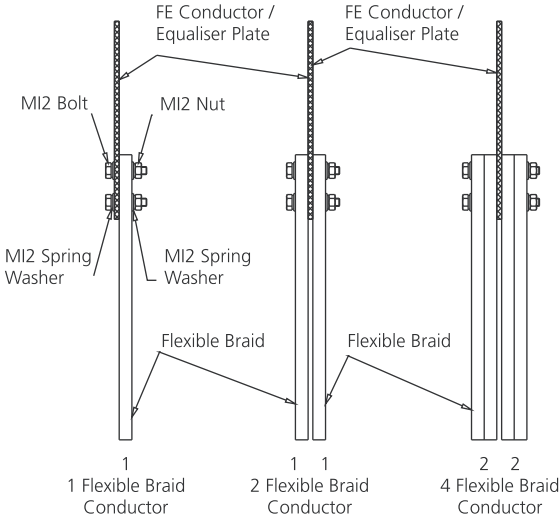

Fig 11

The termination sequence of braid conductors depending upon the number of braid conductors (refer to the Table on page 50) on flanged-end conductors / equaliser plates is to be followed as per the figure above.

## Minimum phase clearance

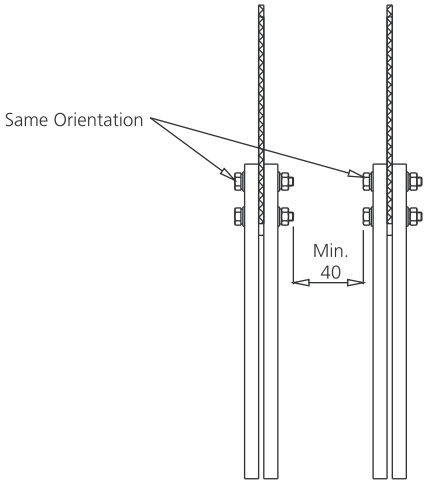
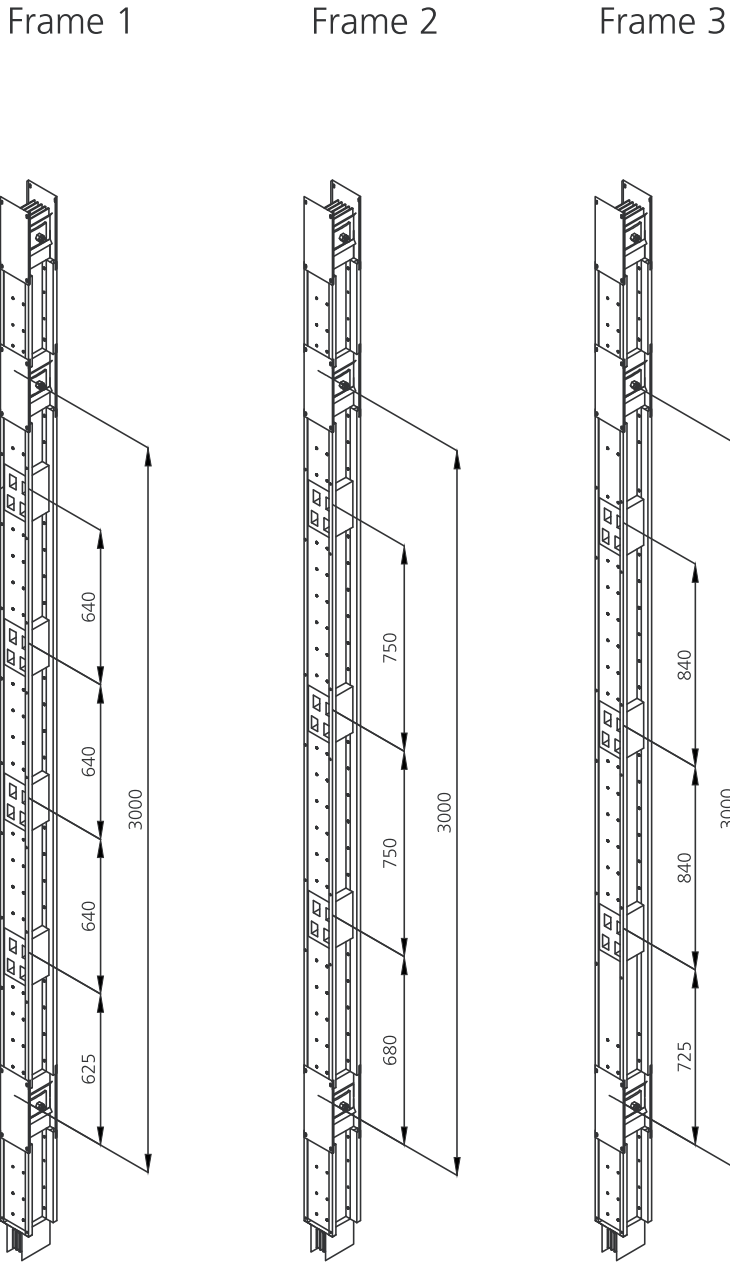

Fig 12

The minimum phase clearance between two phases after braid termination should be 40mm.

# Standardisation guidelines

## Plug in feeder dimensions



The dimensions above are based on a minimum clearance of 300mm between plug-in boxes, and from the joint.  
 Note: For rising mains with vertical spring hanger or fix hanger assembly, please refer to the dimensions below.

	Fr-1	Fr-2	Fr-3
1st PIB location from floor level (mm)	670	725	770

# Standardisation guidelines

## Basic Guidelines

Use standard dimensions on Elbows

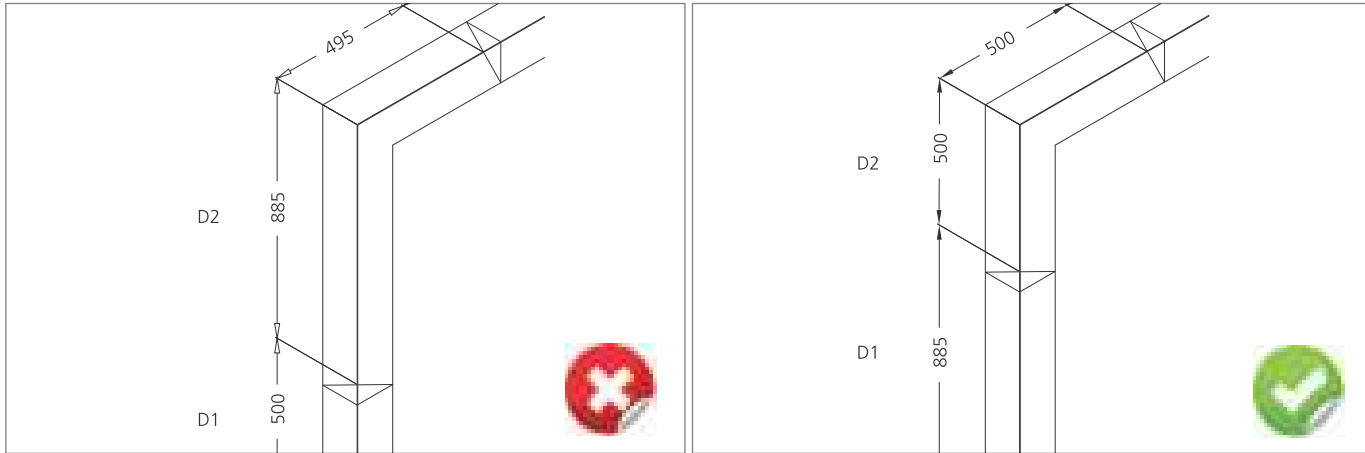

Fig 1 (avoidable practice)

Fig 2 (Best Practice)

Use standard dimensions on elbows (500x500 or 700x700) as per section 4.

Non-standard dimensions should be in feeders or flanged ends.

Fig.1 shows an avoidable practice: a flanged end of 500mm + HE 885x485. The best practices are shown in Figs.2 and 3, i.e. flanged end of 885mm + HE 500x500.

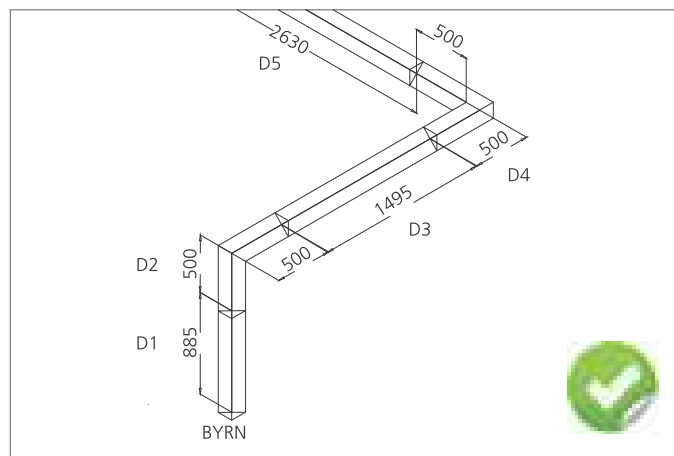

Fig 3 (Best Practice)

# Standardisation guidelines

## Basic Guidelines

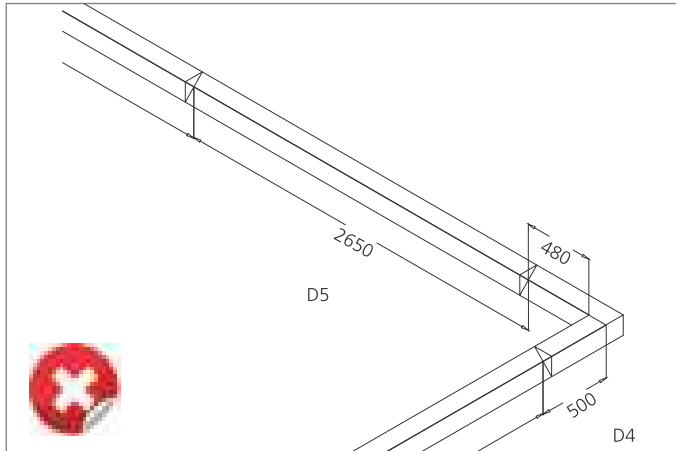

Fig 4 (avoidable practice)

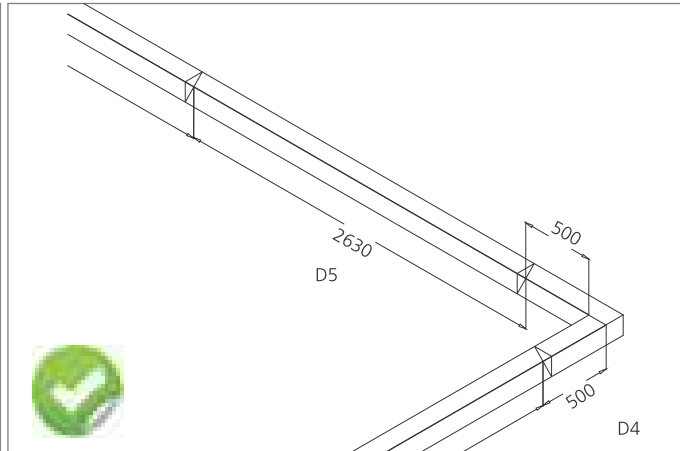

Fig 5 (Best Practice)

- Fig.4 shows an avoidable practice: two non-standard dimensions – feeder 2650 + HE 480x500.
- Fig.5 shows the best practice: feeder 2630 + HE 500x500.

## Dimension least count of 10mm

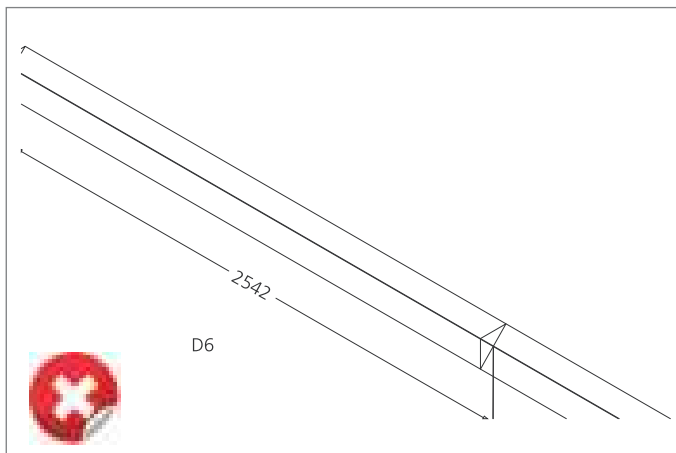

Fig 6 (avoidable practice)

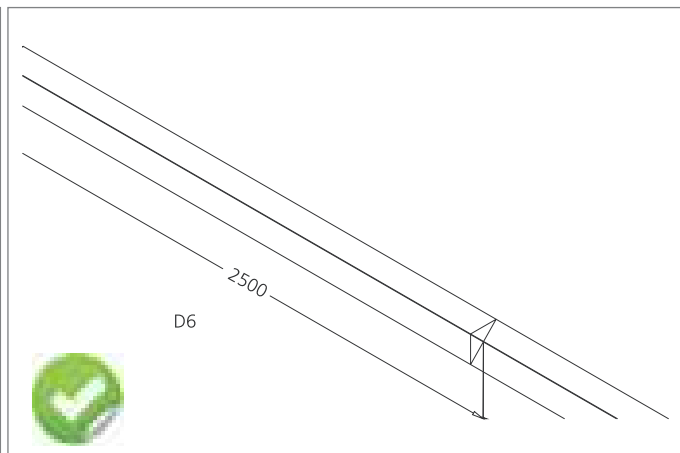

Fig 7 (Best Practice)

The dimensional least count is 10mm. Therefore, the dimensions of the feeder or accessories should be rounded off to the nearest 10mm.

- Example:
  - Feeder/flanged end 2542 should be changed to 2540.
  - HE/VE 452x450 should be changed to 450x450 (if standard dimensions are not possible).

# Standardisation guidelines

## Reduced number of units

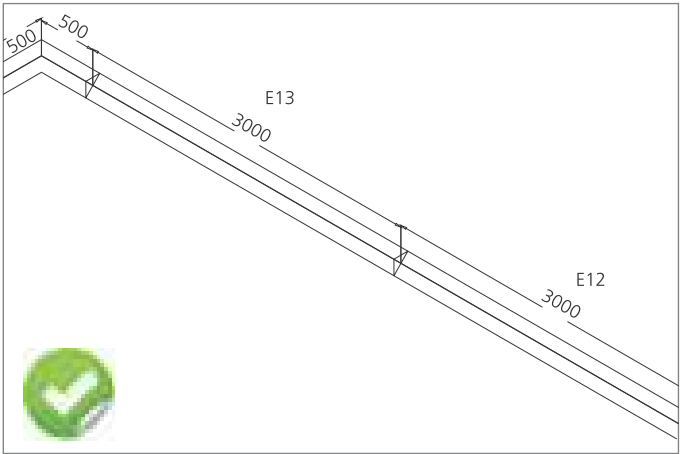
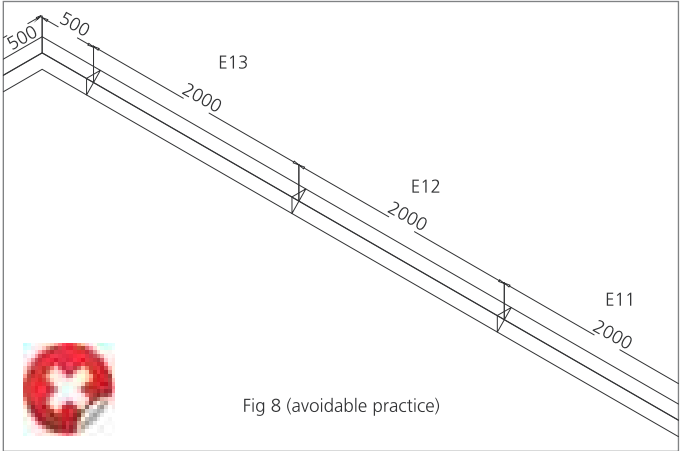

At the design stage itself, we reduce the number of units.  
For example, instead of three 2-metre feeders, we use two 3-metre feeders.

# Standardisation guidelines

## Plug-in Feeder Standardisation

Plug-in feeder plug-in locations should be maintained in the same places. Fig.10A below shows an avoidable practice: in one location it is 2100mm and in another, 1300mm. Instead, it should be 1500mm in both PIFs. In raising mains to maintain PIB locations, shorter additional straight feeders can be added to minimise PIF feeder varieties.

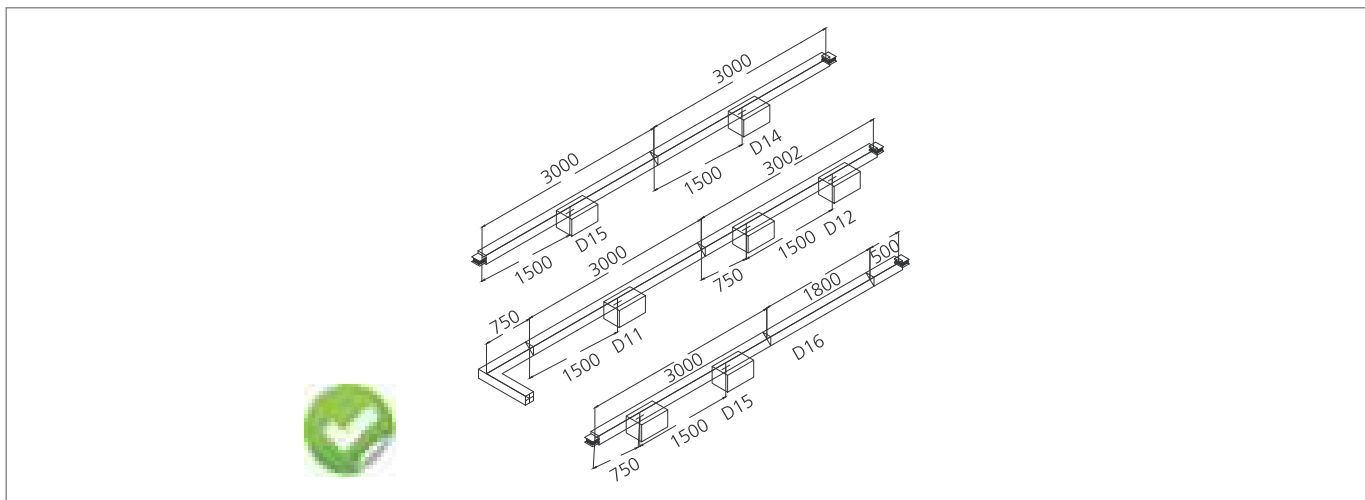
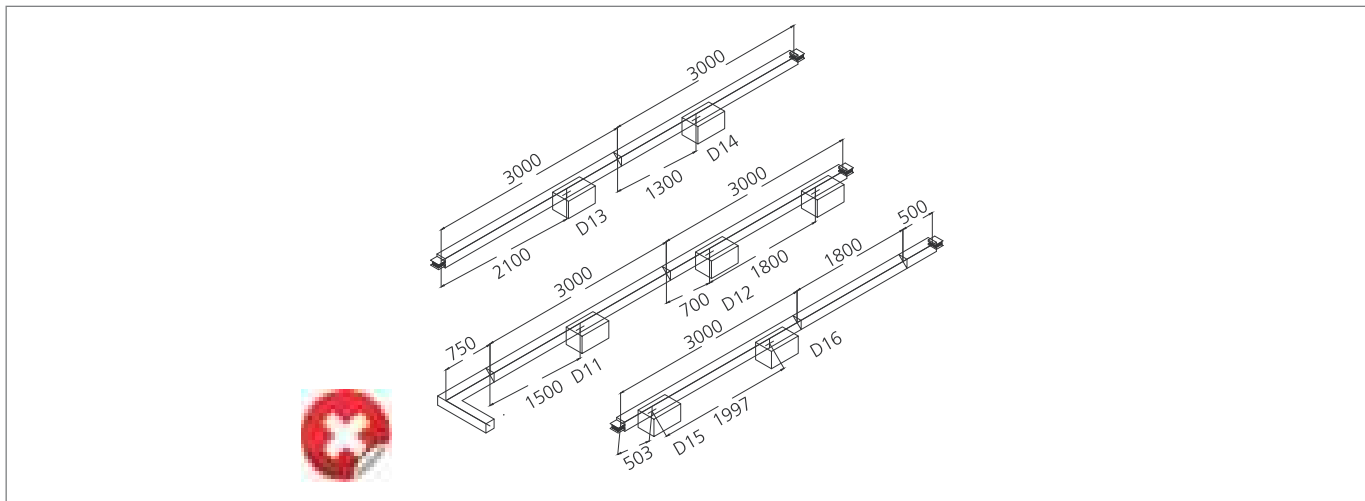

Fig 10

- Fig.11 shows the two varieties of Plug-in Feeders. It can be changed to a single variety.
- Fig.12 shows the best practice: merging the two varieties into a single variety.
- Always follow the standard dimensions in Plug-in Feeder and Plug-in point locations.

# Standardisation guidelines

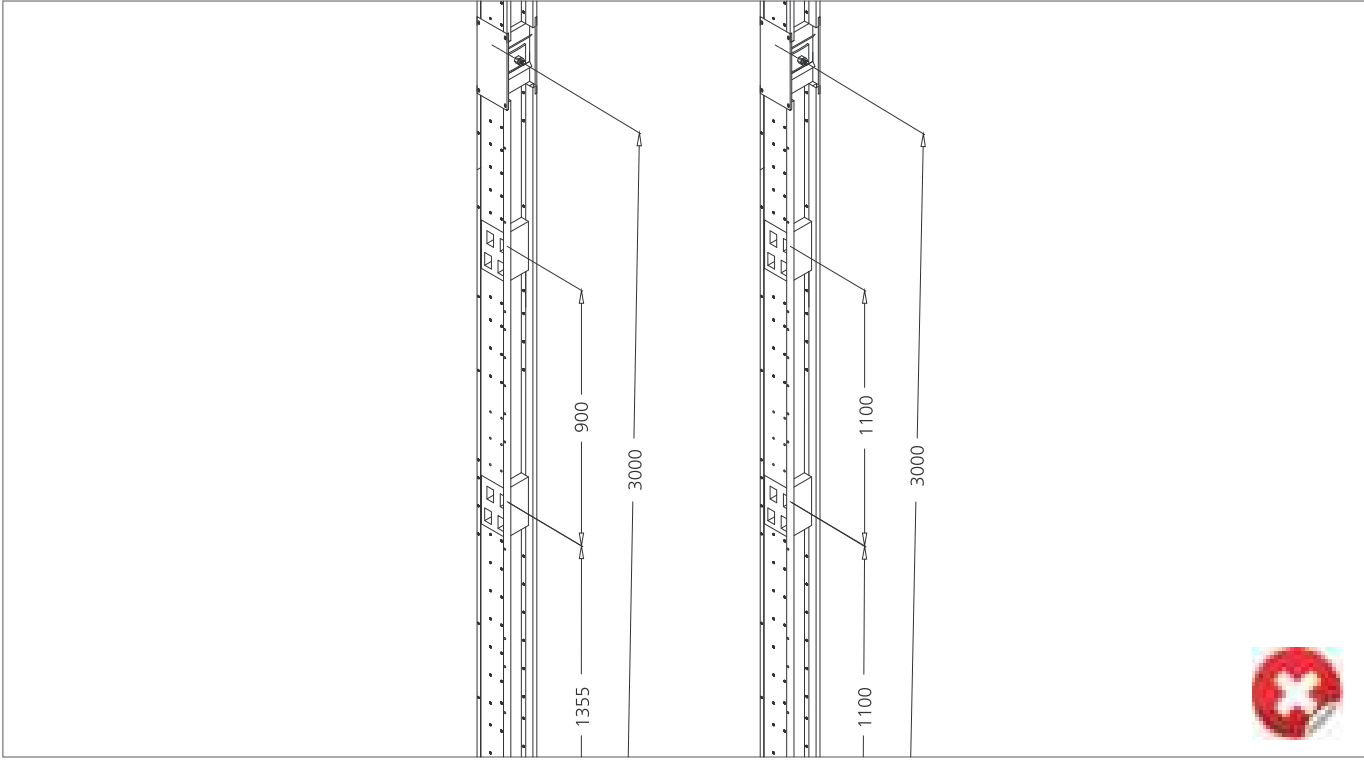

Fig 11 (avoidable practice)

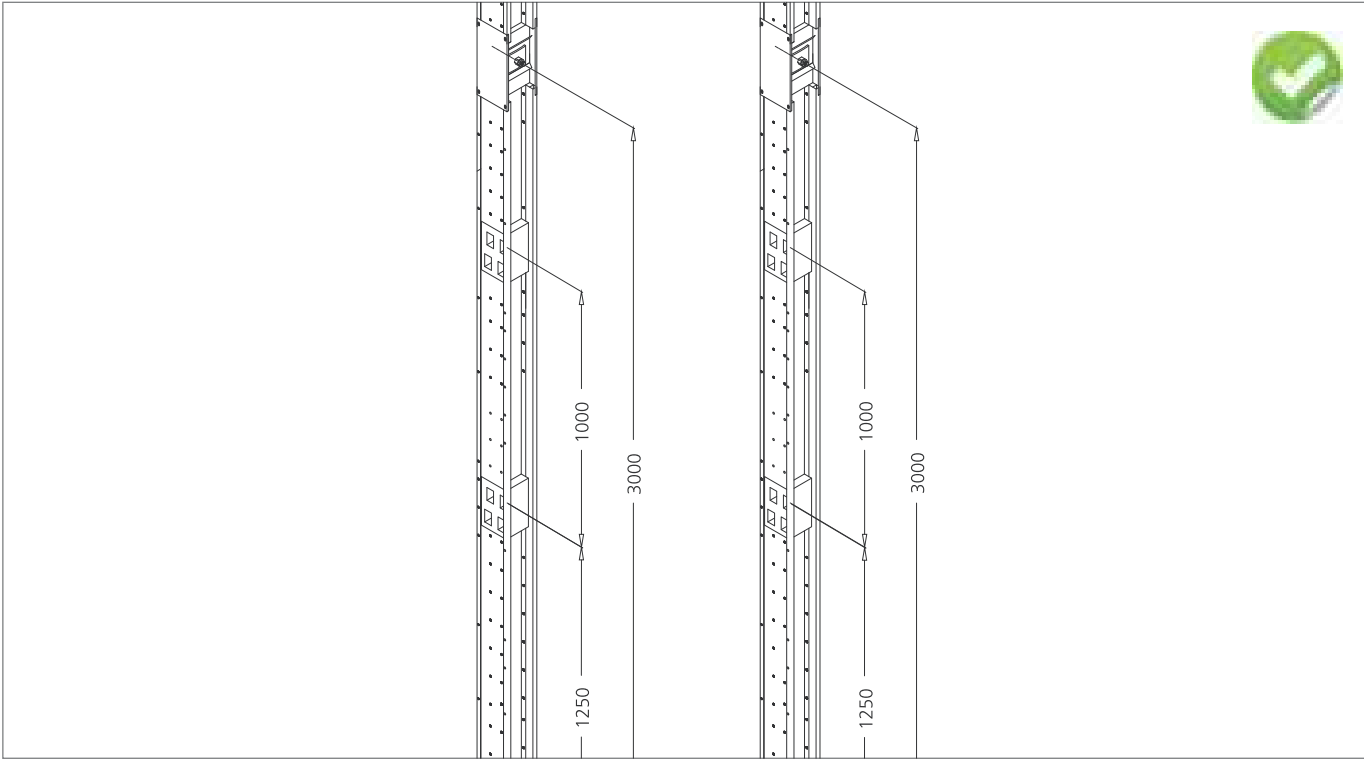

Fig 12 (Best practice)

# Standardisation guidelines

---

## Standardisation priority within accessories

Use the following sequence for prioritising standardisation between modules

	Feeder
	Flanged End
	Plug-in Hole Feeder
	Horizontal Elbow
	Horizontal Elbow with Flanged End
	Vertical Elbow
	Vertical Elbow with Flanged End
	Horizontal Offset Elbow
	Horizontal Offset with Flanged End
	Vertical Offset Elbow
	Vertical Offset with Flanged End
	Combination Elbow
	Combination Elbow with Flanged End
	Vertical Tee Elbow

Examples:

- If there is a choice between a Feeder and a Horizontal Elbow, standardise the Horizontal Elbow.
- If there is a choice between a Horizontal Elbow and a Vertical Elbow, standardise the Vertical Elbow.
- If there is a choice between a Vertical Elbow and a Vertical Tee Elbow, standardise the Vertical Tee Elbow.

# Design factors for busduct layout

## Minimum distance between parallel installed busduct

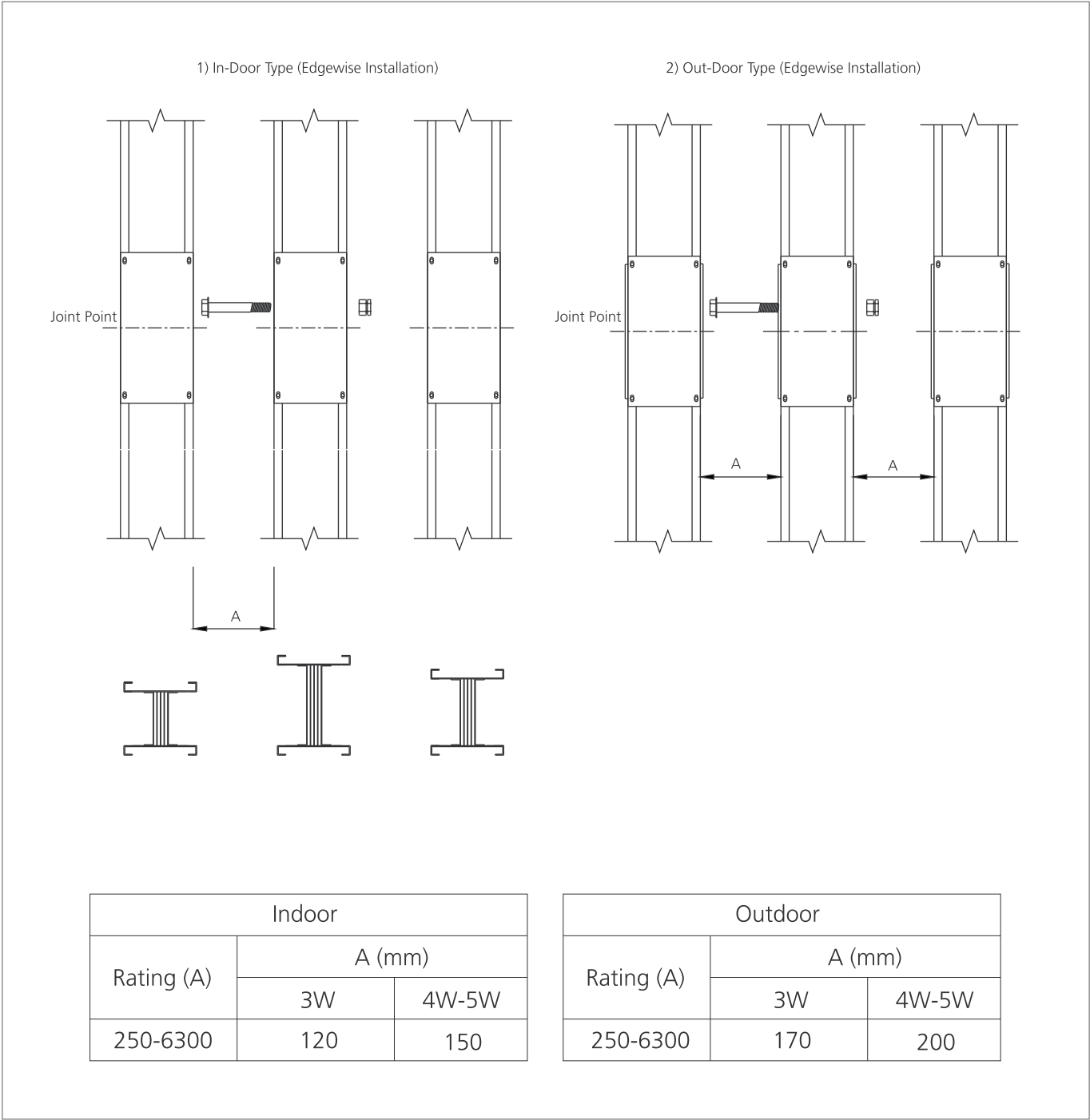

# Design factors for busduct layout

## In-door/Out-door type (flatwise installation)

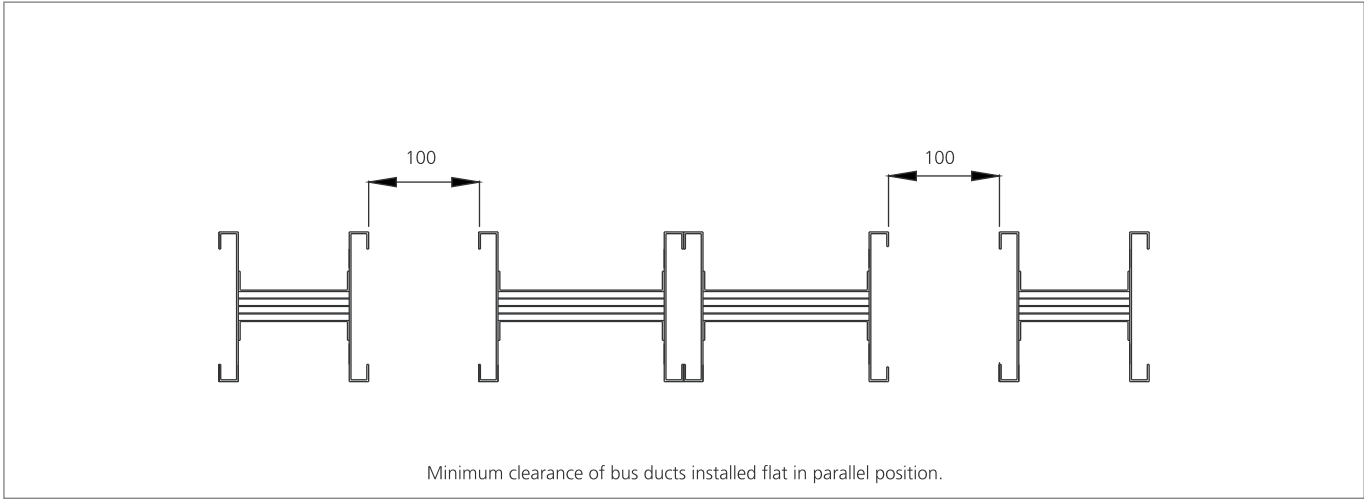

## Plug-In Type

### Minimum clearance of bus ducts installed flat in parallel position

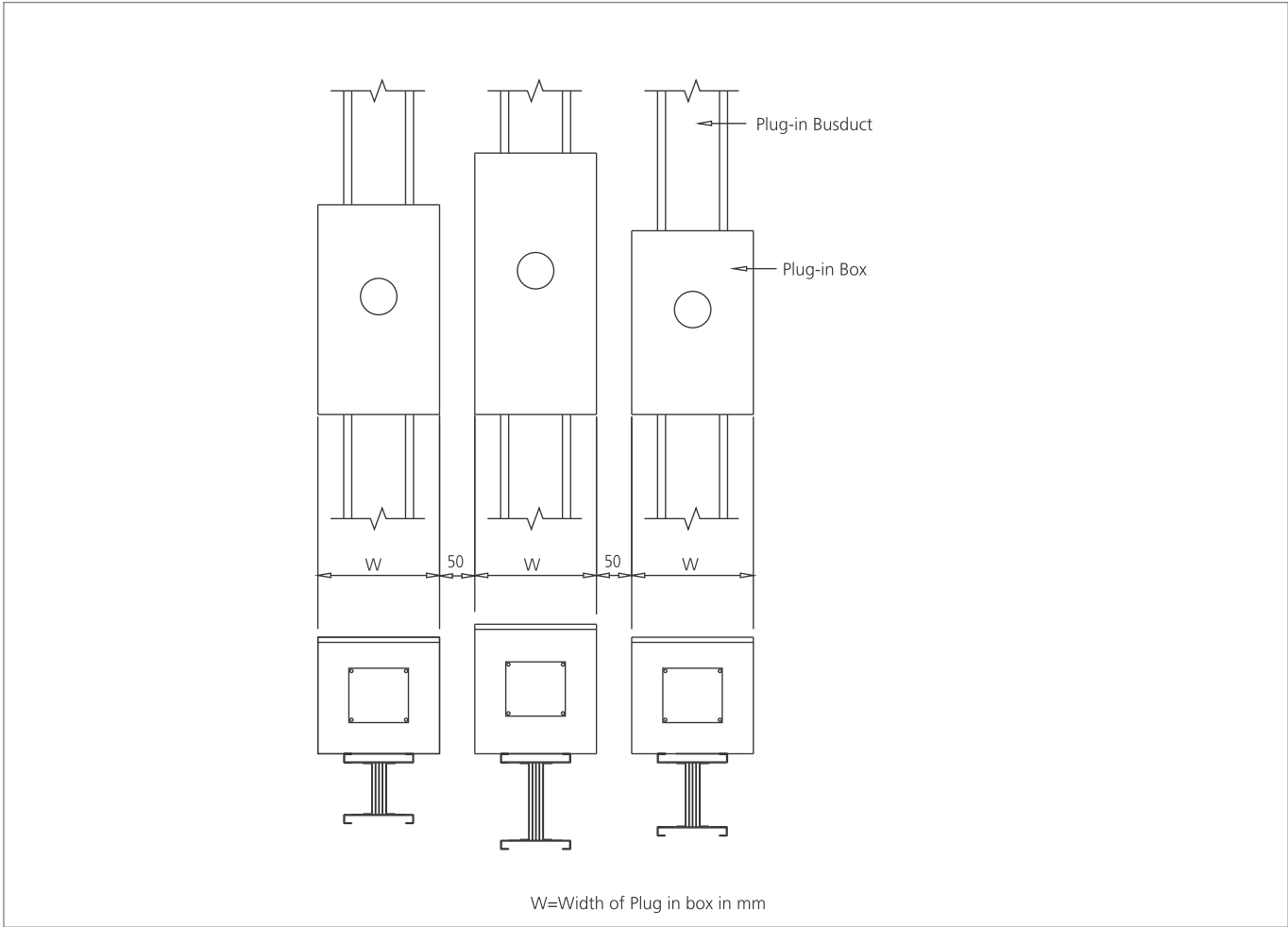

# Design factors for busduct layout

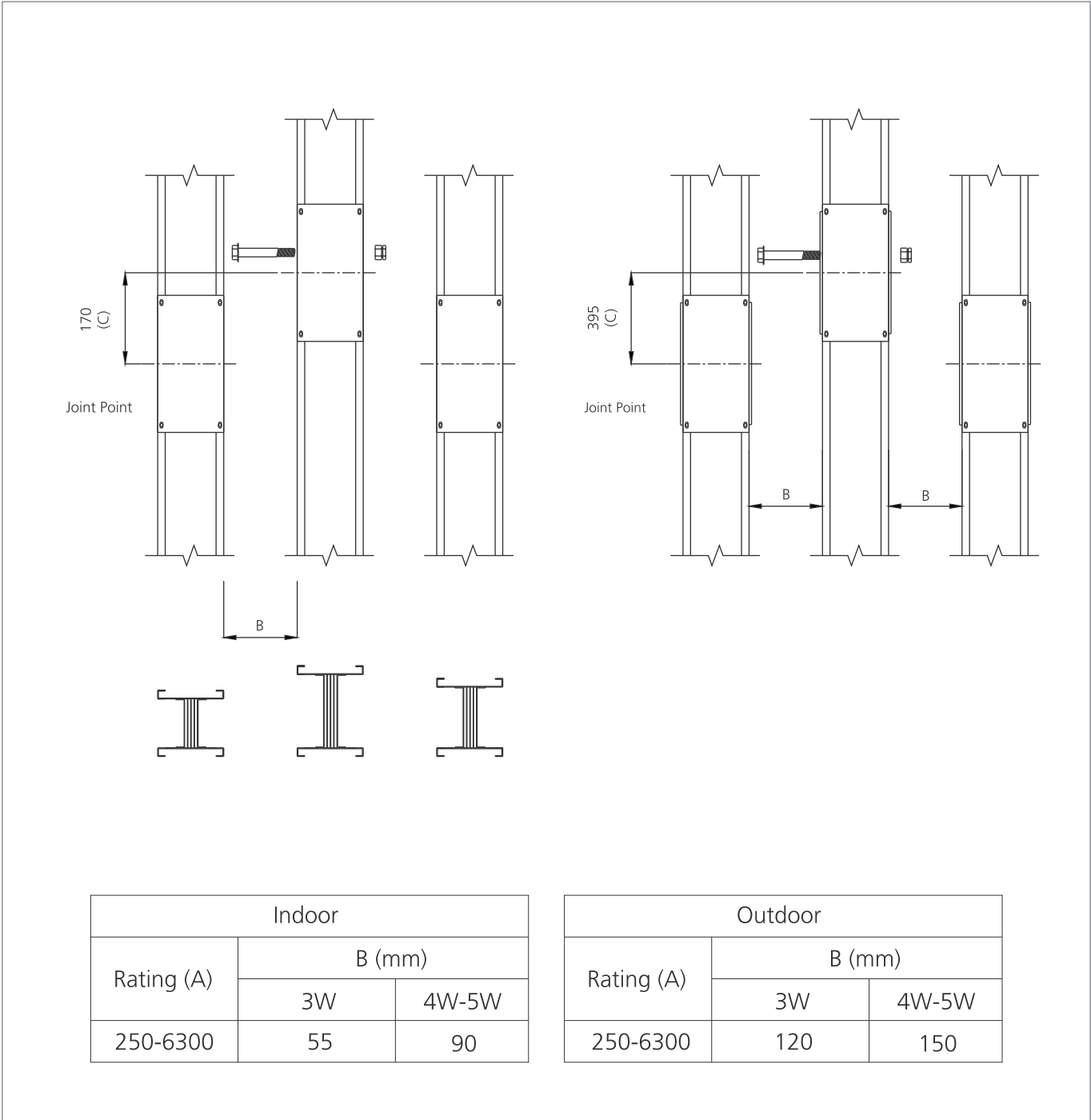

# Design factors for busduct layout

## Minimum Clearance Between Busduct, Wall, Floor, etc.

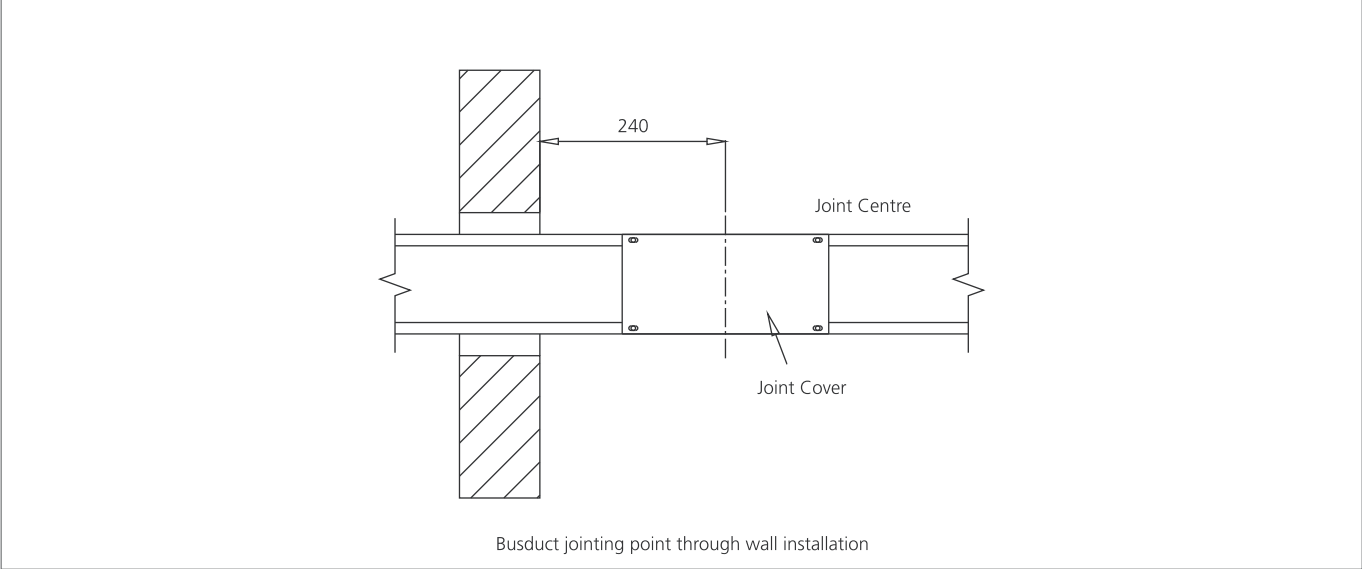
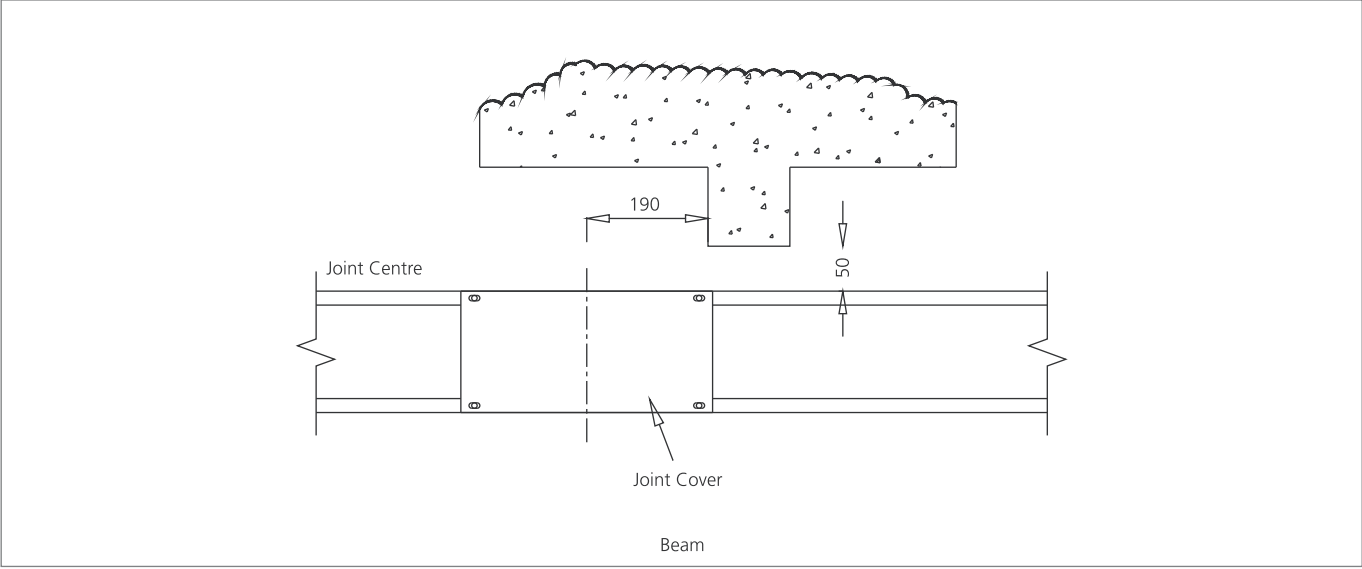
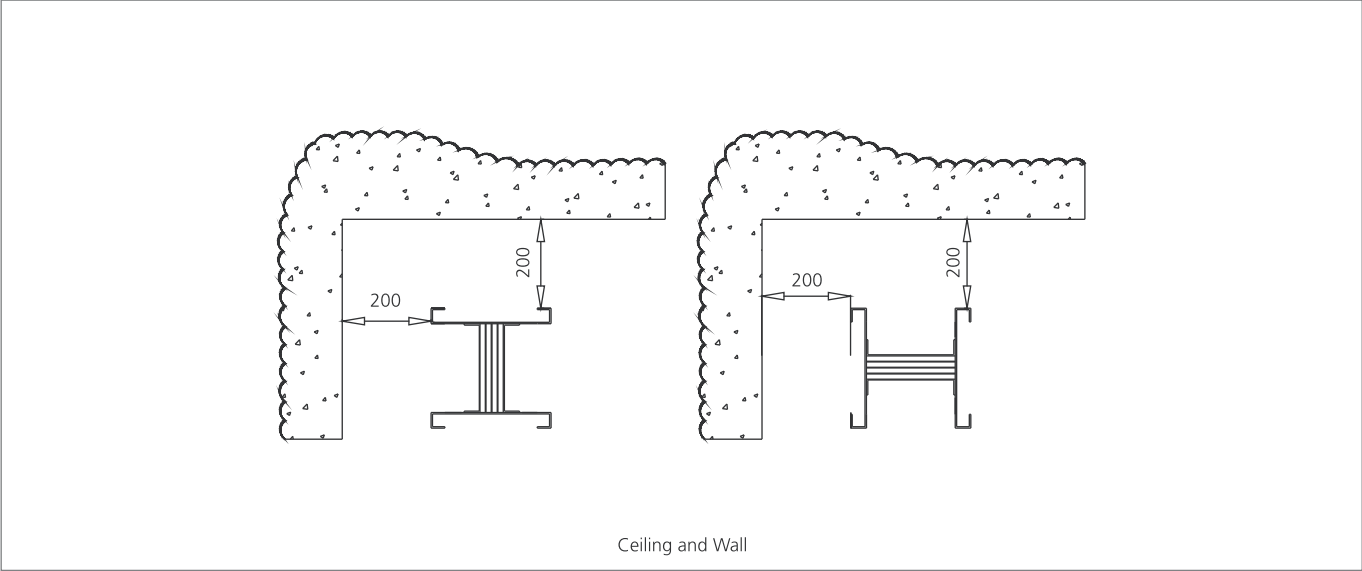

## Design factors for busduct layout

---

### Busduct jointing point and the floor/ceiling surface through floor installation

- Joint should not be installed in between walls or floors.
- Jointing point must be more than 200mm (B) from the surface of a ceiling
- If a vertical spring hanger is to be used on the floor, the distance must be more than 500mm (A).

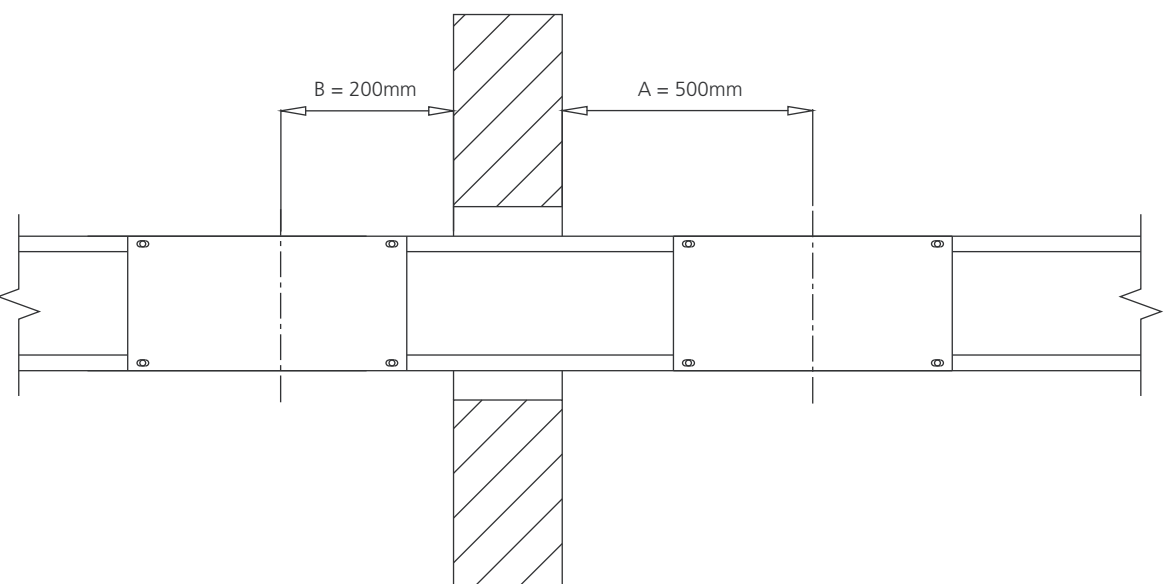

# Busduct Mounting Accessories

## Horizontal hanger assembly

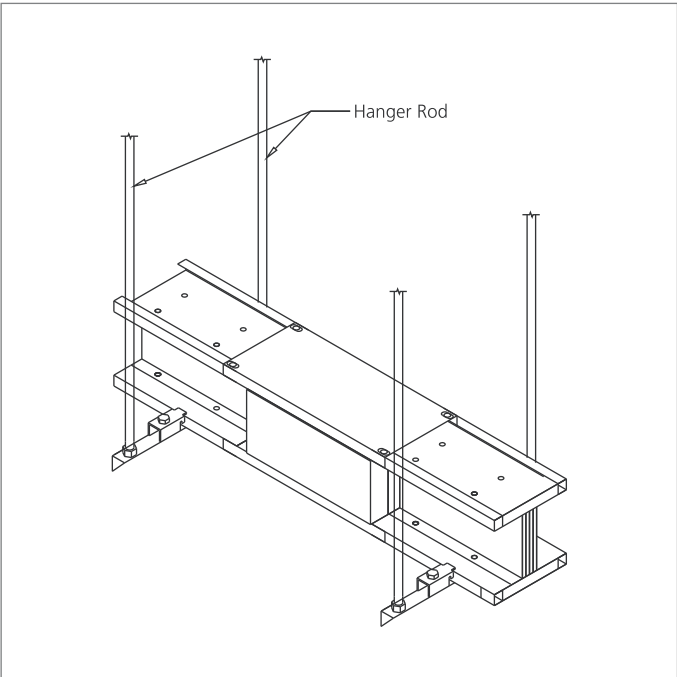
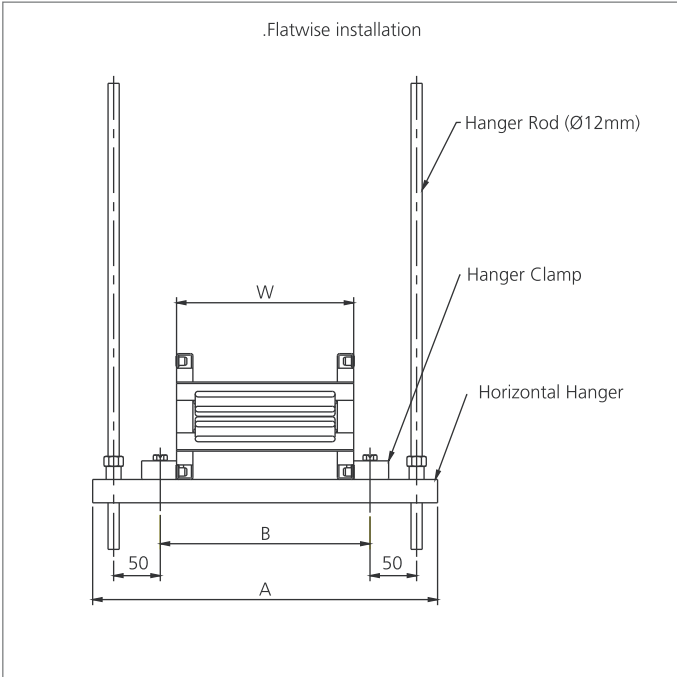
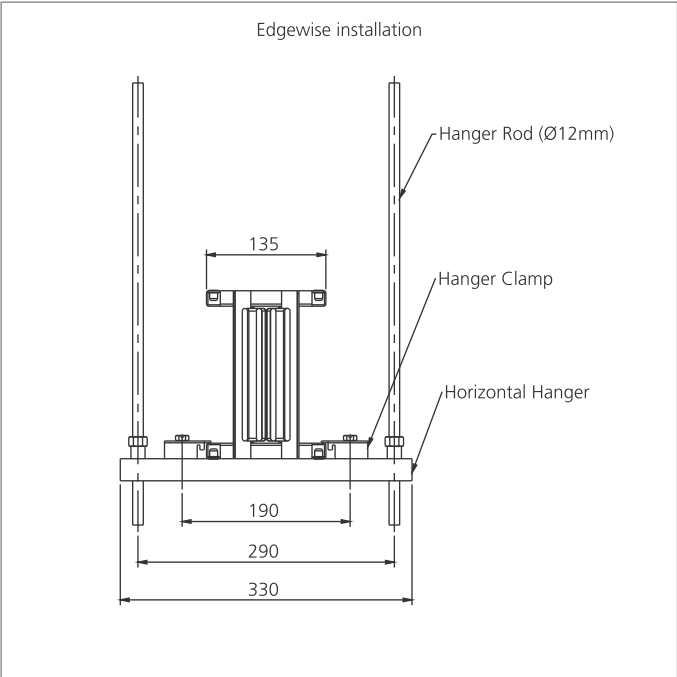

Aluminium Busduct (A)	W (mm)	Copper Busduct (A)	W (mm)
250	70	-	-
400	80	400	78
630	100	630	78
800	120	800	88
1000	140	1000	93
1250	165	1250	113
1600	190	1600	140
2000	240	2000	178
2500	290	2500	213
3200	380	3200	280
4000	480	4000	356
5000	720	5000	426
6300	870	6300	594

# Busduct Mounting Accessories

## Vertical fix hanger & spring hanger assembly

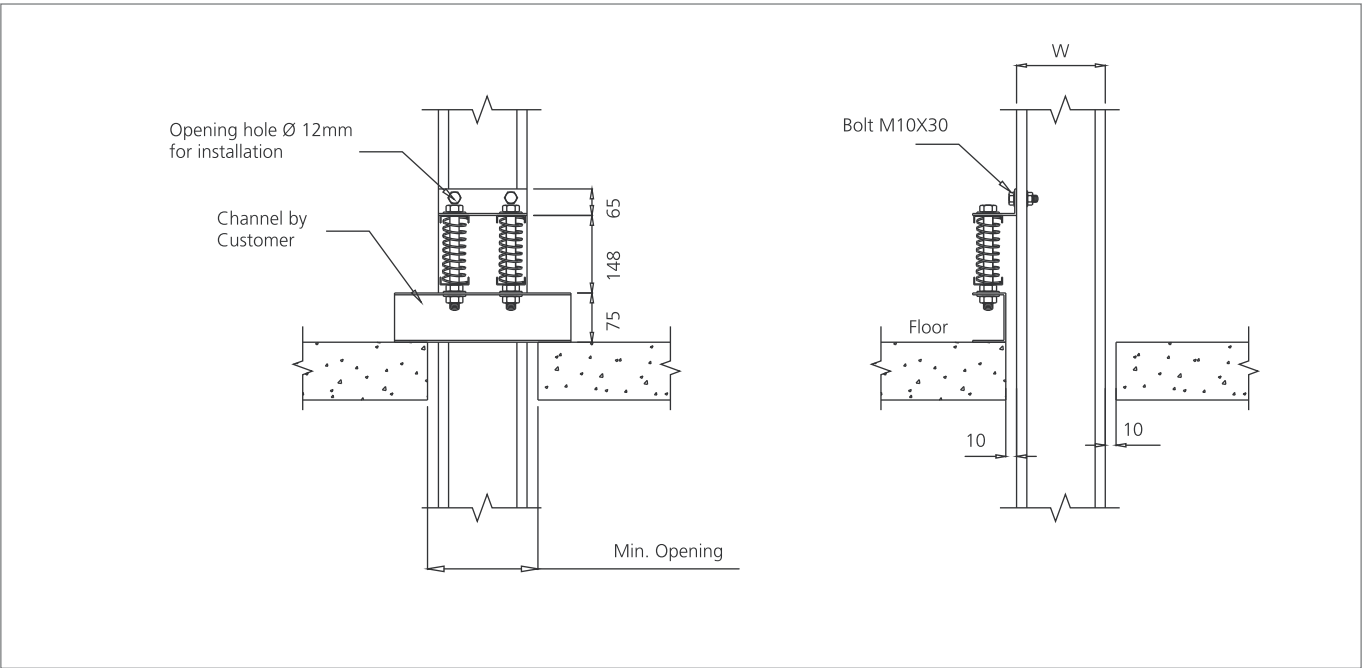
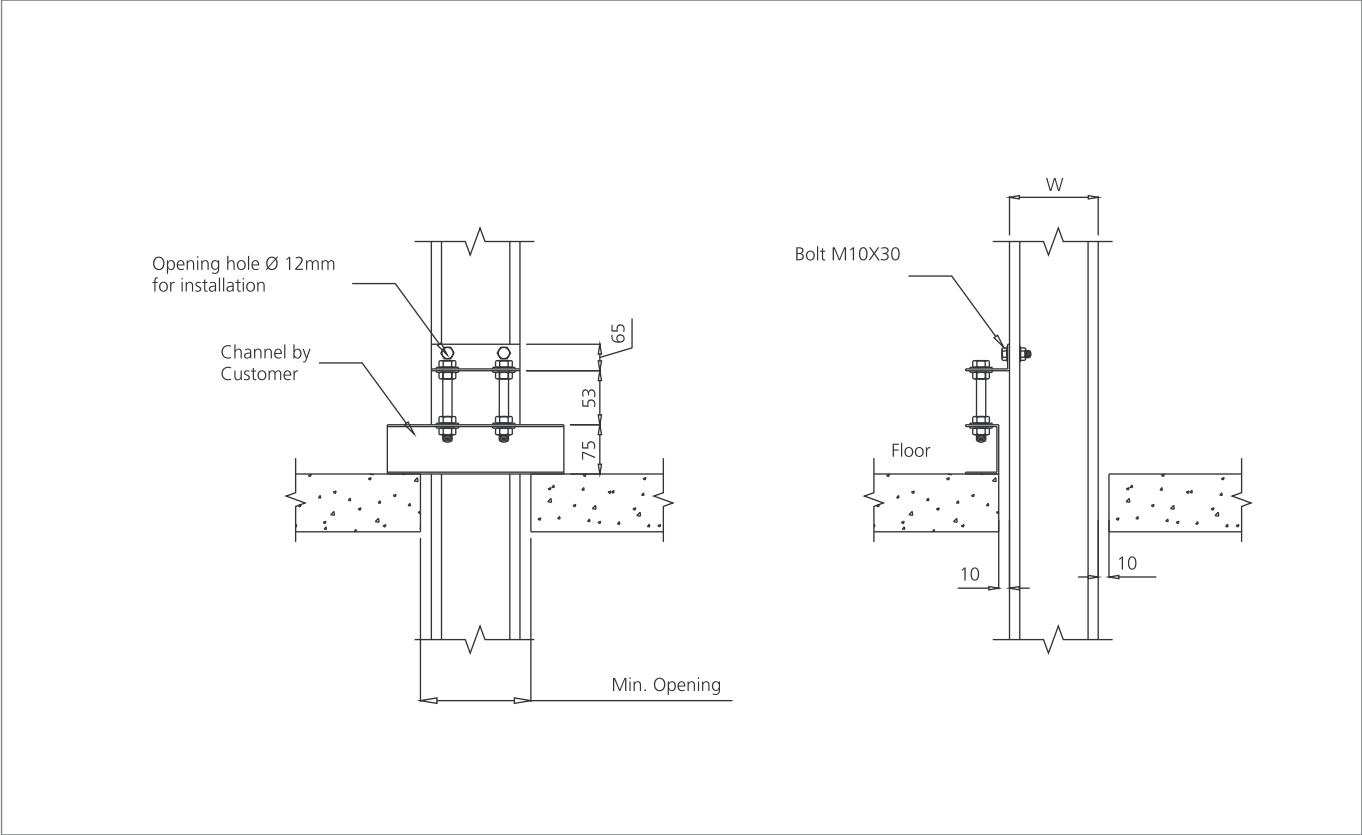

One assembly is required, and it is to be installed for one side.

# Busduct Mounting Accessories

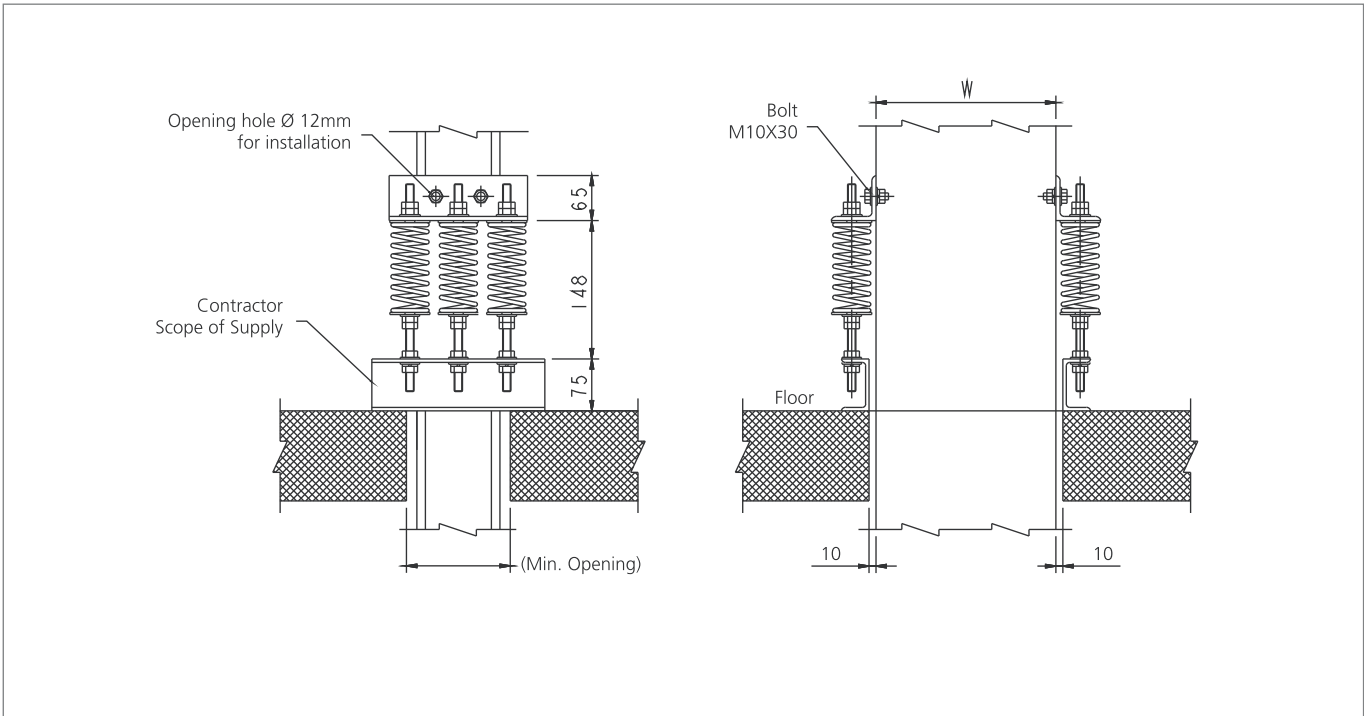
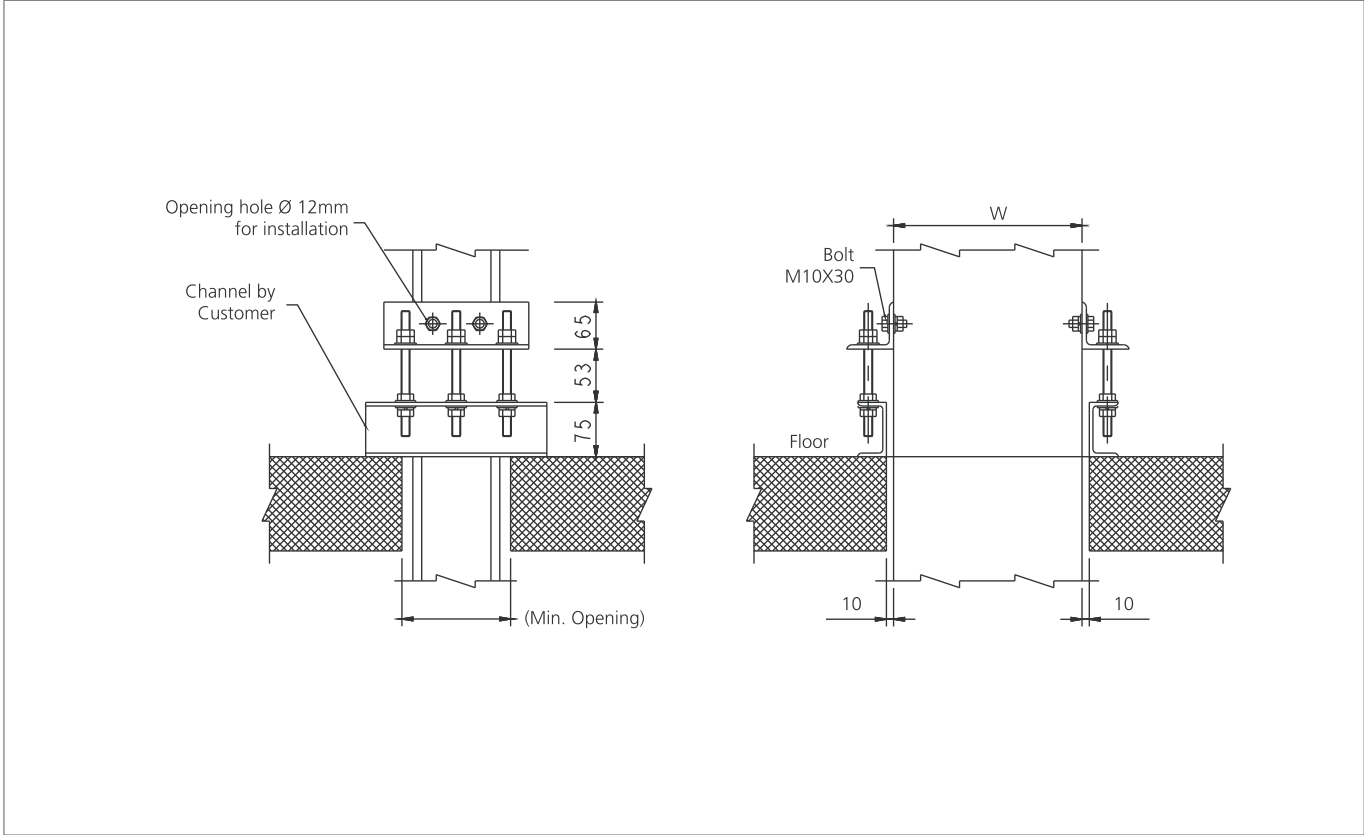

Quantity of assemblies required is 2 and they are to be installed on both sides.

# Installation Guidelines

---



## 1. General

- 1.1 Proper planning and coordination between contractors, suppliers and project managers is important for a good busduct system layout.
- 1.2 The successful operation of a busduct system depends upon proper handling, installation, operation and maintenance, as well as upon proper design and manufacture. Neglecting certain fundamental installation and maintenance requirements may lead to personal injury and damage to electrical equipment or other property.
- 1.3 Installation, operation, and maintenance of a busduct system should be undertaken and supervised only by qualified personnel.
- 1.4 For the purpose of these guidelines, a qualified person is one who is familiar with the installation, construction and operation of the equipment and the hazards involved. In addition, s/he has to be:
  - Trained and authorised to test, energise, clear, ground, tag, and lockout circuits and equipment in accordance with established safety practices,
  - Trained in the proper care and use of protective equipment such as rubber gloves, helmet, safety glasses or face shields, and flash-resistant clothing in accordance with established safety practices,
  - Trained in rendering first aid.

## Installation Guidelines

### 2. Unpacking

- 2.1 Care must be taken while unpacking. Band cutters should be used to cut all steel straps securing the package
- 2.2 Nail pullers should be used for unpacking wooden crates to avoid damage.
- 2.3 Carefully remove any support blocks which may have been used for shipping.
- 2.4 When the Bus duct system received at site, unpack temporarily to inspect its physical condition. Also check and ensure that the consignment is complete and correct as per order, packing list, drawings.
- 2.5 Restore the materials in original packing condition, if it is required to be stored for longer period prior to installation.
- 2.6 It is recommended to remove polythene sheet (covering the ends of busduct accessories) only at the time of installation, in order to protect it from water, slurry, etc.



## Installation Guidelines

### 3. Handling

- 3.1 Handle busduct with care to avoid damage to internal components and enclosure or its finish
- 3.2 Avoid subjecting busduct to twisting, denting, impact and, in general, rough handling.
- 3.3 Do not use busbar ends for lifting Busduct system sections or fittings.
- 3.4 If the busduct system is to be stored prior to installation, restore packing for protection during that period (See Fig. 1). When conditions permit, leave the packing intact until the sections or fittings are at their final installation location.
- 3.5 Verify that the weights of any busduct sections or fittings are within the rated capacity of the handling equipment to be used.
- 3.6 Platform dollies provide a simple method of moving busduct on one floor level if there is little or no incline. Balance the load carefully.
- 3.7 A fork-lift truck may offer a more convenient method of handling busduct and has the added advantage of permitting it to be hoisted between levels. Balance the load carefully.
- 3.8 Platform lifts or elevators, either manually or power operated, can be used advantageously in moving loads of busduct between elevations.

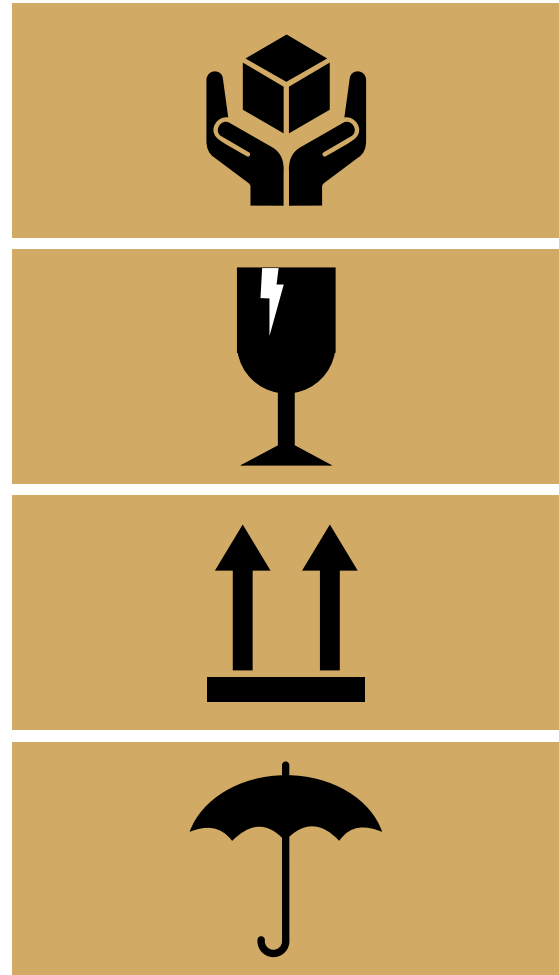

# Installation Guidelines

## 4. Storage

- 4.1 Busduct sections and fittings which are not to be installed and energised immediately should be stored in a clean dry space having a uniform temperature to prevent condensation. Preferably, store them in a heated building with adequate air circulation, protected from dirt, fumes, water, and physical damage.
- 4.2 Avoid storing the busduct outdoors. Protect busduct from dust and water by covering it with the waterproof sheet. (Fig. 1)

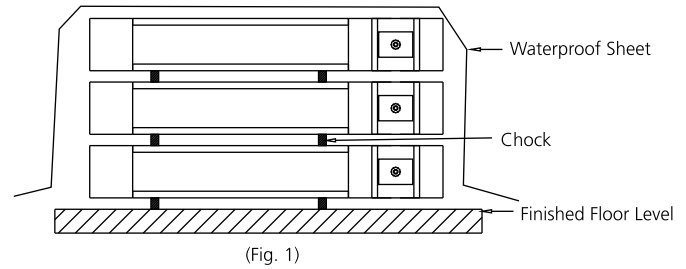

- 4.3 If it must be stored outdoors, cover the busduct securely to protect it from weather and dirt. Temporary electrical heating should be installed beneath the cover to prevent condensation.
- 4.4 Outdoor busducts are not weather-resistant until completely and properly installed and should, therefore, be treated exactly the same as indoor busducts until after installation.
- 4.5 Busducts should always be placed on the floor horizontally, with the chocks or forms placed underneath the busducts. (Fig. 2)

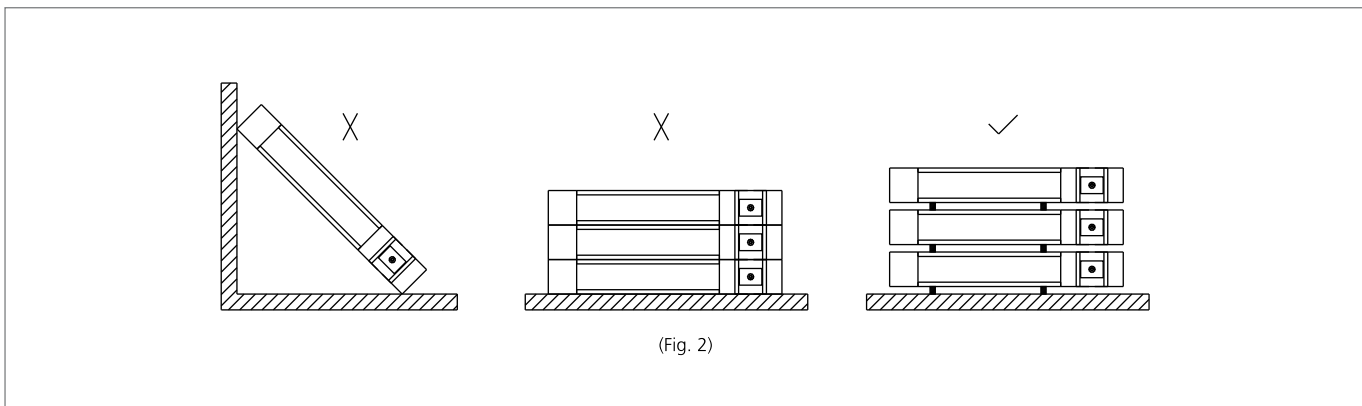

Recommended Number of Stacks for Storage

Busduct Rating (A)	Number of Stacks
250A – 1000A	Max. 5
1250A – 2500A	4
3200A – 5000A	2
6300A	1

- 4.6 A busduct system which is in an idle state, even if installed, needs to be protected adequately by suitable means.

# Installation Guidelines

## 5. Operation

5.1 Provide sufficient horizontal and vertical clearance from walls and ceilings to provide easy access to joints, both for the original installation and possible removal of a section when required.

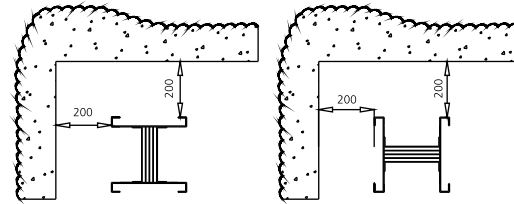

(Fig. 3)

5.2 Table 1 shows the approximate weight of a busduct. However, the weight of special busducts (e.g. flanged end, expansion joint, etc.) should be considered during transporting the units as it is heavier than the weight calculated.

(Table 1)

Aluminium Rating (A)	Weight(kg/m)*			Copper Rating (A)	Weight(kg/m)*		
	Indoor Busduct				Indoor Busduct		
	3W	4W	5W		3W	4W	5W
250A	7	7	8	-	-	-	-
400A	8	9	9	400A	8	10	11
630A	10	11	12	630A	10	12	14
800A	11	13	14	800A	12	15	18
1000A	13	15	16	1000A	13	16	19
1250A	15	17	19	1250A	17	21	25
1600A	17	19	22	1600A	23	28	33
2000A	21	25	28	2000A	30	37	45
2500A	25	29	33	2500A	37	46	55
3200A	34	38	44	3200A	49	56	70
4000A	42	50	56	4000A	60	75	89
5000A	63	75	84	5000A	74	92	111
6300A	75	87	99	6300A	102	127	152

\*:Weight is for straight feeder and is with tolerance of +-5%

5.3 Avoid subjecting the busduct to twisting, denting, and impact and, in general, rough handling. Especially ensure that the busduct ends are not hit against the structures or equipment. Do not allow the busduct to stand against the walls or other structures.

5.4 Suitable and certified hoisting wire or chain pulley should be used to hoist the busduct for easy installation and also to avoid damage to the busduct housing and earthing clamp.

5.5 Ensure that the busduct weight is properly distributed. A careful approach is a must to ensure avoiding any damage to the housing that could pinch the busduct insulation and result in a failure.

5.6 Do not directly fix the hoisting wire to the joint cover hole on the housing, instead, use a lifting jig for both horizontal and vertical busduct installation

5.7 The joint block hole should not be used for hoisting as it cannot withstand the weight of the busduct which would result in dismantling the joint block from busduct or any damages.

5.8 Do not drag the busduct across the floor.

5.9 When installing the vertical riser, it is easier to lower the busduct from the floor above where it will be installed. Vertical sections are often stored on the floor above their final location to facilitate lowering them into position. Ensure that the weight of the feeder on the opposite side of the hoisting rests on the support in order to prevent any damage to the joint.

5.10 Hang one busduct unit with two hangers in principle.

5.11 Depending on site conditions, it is preferable to first install the flanged end, the flanged end box and the cable feed box, followed by the subsequent unit numbers.

## 6. Protection against Ingress of dust and water

The ingress of dust and water into the busduct will decrease electrical and physical properties and cause dielectric damage. To prevent this, take precautions against the ingress of dust and water during storage and installation. Common sources of such contaminants include:

- During construction – Indoor busducts must be protected from moisture and water during and after installation. Special attention should be given to riser busducts during construction to protect them from moisture and water from uncompleted roofs, walls, etc.
- Outdoor busducts are not weather-resistant until completely and properly installed and should be treated exactly the same as indoor busducts until after they are constructed. They are not weather resistant until completely and properly installed. It is recommended to use canopy over outdoor busduct installation.
- Floor-level liquids – Bund wall of at least four inches high should be installed around all floor openings for riser busducts to prevent floor-level liquids from entering the opening.

## Installation Guidelines

---

- Leaking Roof – Protect indoor busduct with a temporary sheet metal shield or other protective cover to prevent water from falling onto the busduct until the roof is repaired.
- Pipes – Protect indoor busduct with a temporary sheet metal shield or other protective cover to prevent water from falling on to the busduct until leaking pipes are repaired. Where pipes (especially cold water pipes) pass directly above an indoor busduct, the busduct should be protected from dripping condensate by insulating the pipe or permanently shielding the busduct with sheet metal or plastic.
- Sprinklers – Protect indoor busduct from direct spray of sprinklers.
- Snow – Outdoor busduct should be mounted sufficiently above the ground or roof so that snow build-up does not surround the busduct and result in water being forced into the busduct through the weep holes.

### 7. Summary

- 7.1 Review final approved drawing as per actual site condition along with drawing of equipments (Transformer, Panel etc.)
- 7.2 Check the bill of material.
- 7.3 Check description, tag no and identify each piece before installing it.
- 7.4 Follow the manufacturer's joint assembly instruction drawing and video for both indoor and outdoor procedures.
- 7.5 Conduct an insulation resistance test on each section of the busduct before it is installed.
- 7.6 Conduct an insulation resistance test on the portion of each run already installed on a daily basis.
- 7.7 Check for possible sources of water that may fall on indoor busducts, and take corrective action to prevent this.

### 8. Flange End Termination

- Flange end is starting point of busduct system routing. Installation must be started from flange end of busduct route.
- 8.1 Place the flange end support plate on the end feed box or panel or adaptor box kept on transformer/ DG set/ panel.
  - 8.2 Securely tightened the hardware if flange end support plate to fix the flange end on transformer/ DG set/ panel.
  - 8.3 Ensure that phase sequence of flange end is matching with phase sequence of transformer/ DG set/ panel.
  - 8.4 Ensure that all the contact surfaces of flange end conductors and transformer/ DG set/ panel are free of contaminants.
  - 8.5 Select the flexible braid of required cross-section and quantity as per guidelines. Make the flexible connection at flange end side and transformer/ DG set/ panel side as shown in fig no 4.
  - 8.6 In case of multi stack busduct, flange end terminal to be started using equalizer plate (R1 & R2, Y1 & Y2, etc.). Then flexible between equalizer plate and transformer/ DG set/ panel terminals to be connected.
  - 8.7 Minimum clearance between two phases after braid termination should be as per standards.

# Installation Guidelines

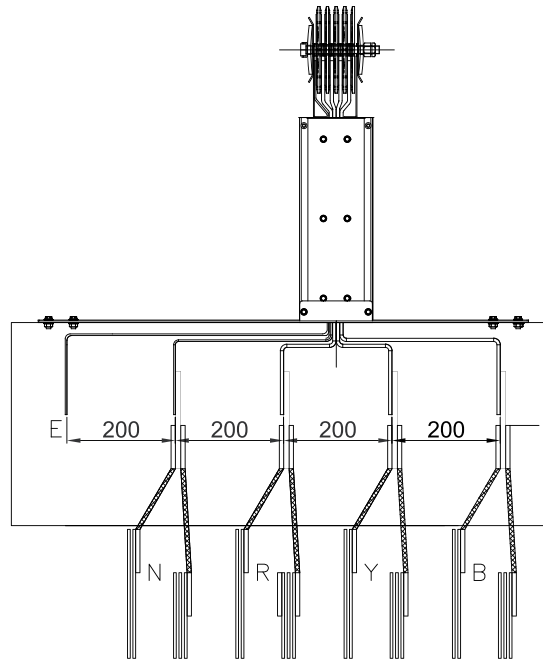

(Fig. 4)

## 9. Joint Assembly

The joint section is the heart of the busduct system during its operation, so proper tightening of the joint bolt is important to ensure its continuous satisfactory operation.

- 9.1 Ensure that all contact surfaces are clean and free of contaminants by using a dry cloth.
- 9.2 Align the busduct ends of adjoining sections, verifying proper phase alignment, and slide the sections together as illustrated in Fig. 5
- 9.3 For easier connection of 'supply' and 'load' side and less impact of the busduct weight during vertical installation, a certain interval has to be kept. Use the joint cover by screwing the bolt on the lower part of the joint cover then follow by screwing the upper part of the joint cover. This enables easy jointing and accurate jointing interval (Figs. 6 and 7).
- 9.4 Install the joint cover on the bottom of the jointing section.
- 9.5 Join the two sections until the joints have adequate and proper contact surfaces, phase by phase.
- 9.6 Ensure that load and supply sides are aligned correctly. And the gap between enclosure of two elements must be 250mm
- 9.7 Insert the joint bolt through the joint hole and tighten it along with plate spring and MF nut with the torque wrench. Ensure tightening of the joint bolts as per Torque values mentioned in below table,

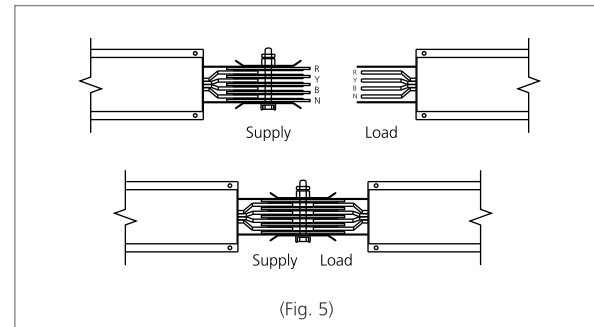

(Fig. 5)

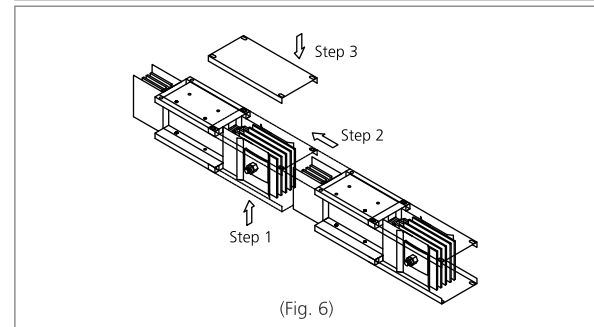

(Fig. 6)

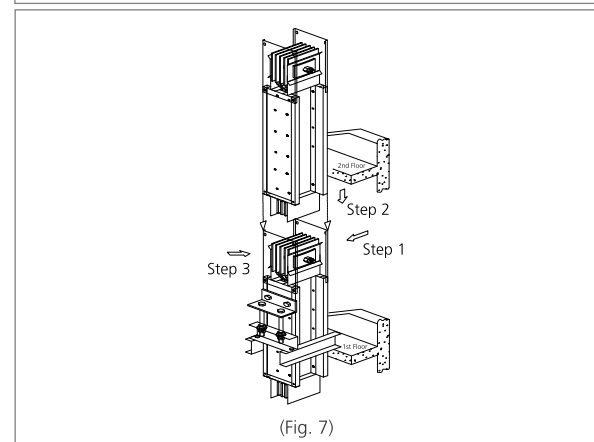

(Fig. 7)

# Installation Guidelines

Conductor	Rating	Tightening Torque
Aluminium	250A to 800A	90 N-m
	1000A to 6300A	150 N-m
Copper	400A to 1250A	90 N-m
	1600A to 6300A	150 N-m

The outer nut of the lock nut should tilt at the stated torque values.

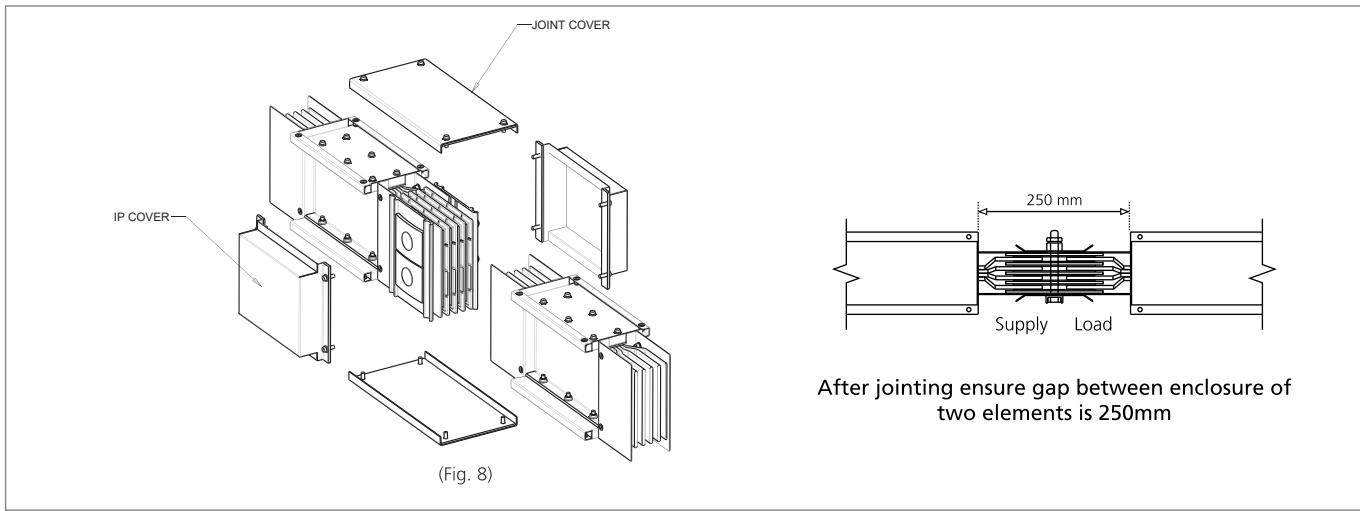

- 9.8 For IP66, install the side cover with gaskets on both sides.
- 9.9 Install the joint cover with the gasket on the top of the jointing section.
- 9.10 Apply the sealant provided by the manufacturer for IP66 busducts on all joint blocks.

- 9.11 Ensure that the busduct installation is in straight alignment, whether horizontally or vertically, in order to obtain a proper jointing system. (Fig. 10)
- 9.12 It is also recommended to install Canopy on outdoor installed busduct

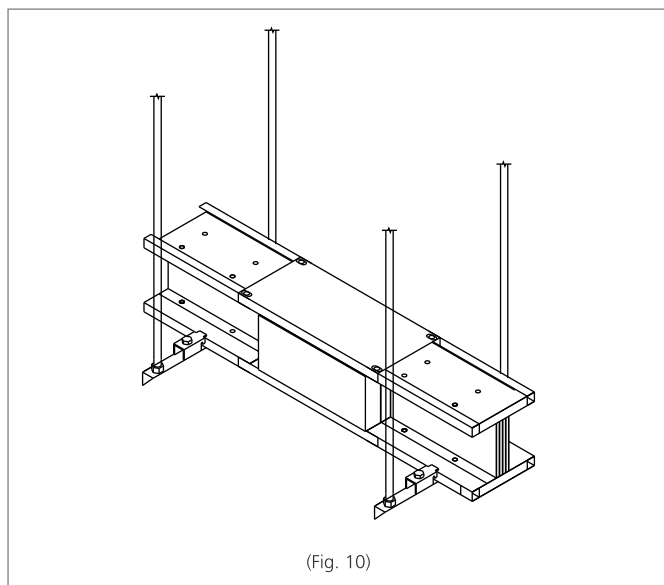
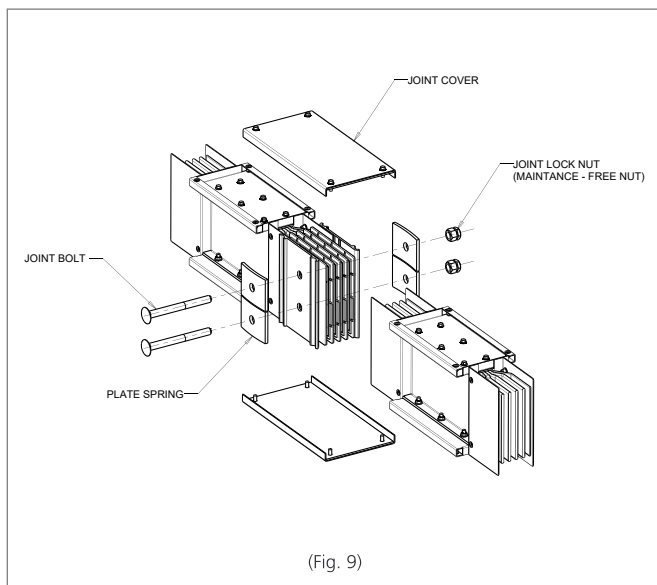

# Installation Guidelines

## 10 Horizontal hanger installation

- 10.1 Fix horizontal hanger to the hanger rod and adjust it for correct elevation of the busduct as per site conditions. Ensure that length of hanger rod should not be more than 1.5 meters. There should not be any welding in rod.
- 10.2 Lay the busduct on the horizontal hanger.
- 10.3 Ensure the busduct is aligned in a straight line, and no support should be given below joint block. as shown in fig 11
- 10.4 Install the hanger clamp on both side of the busduct for fixture.
- 10.5 Additional horizontal hangers should be used for flanged end, elbows, such as vertical/ horizontal elbows, offset elbows, combination elbows, etc.
- 10.6 Supporting interval of horizontal hanger should not exceed 1.5 meters. and ensure one support for each element to avoid stress on joints.
- 10.7 Adjust the nut of horizontal hanger to ensure that there is no gap between horizontal channel and busduct element.

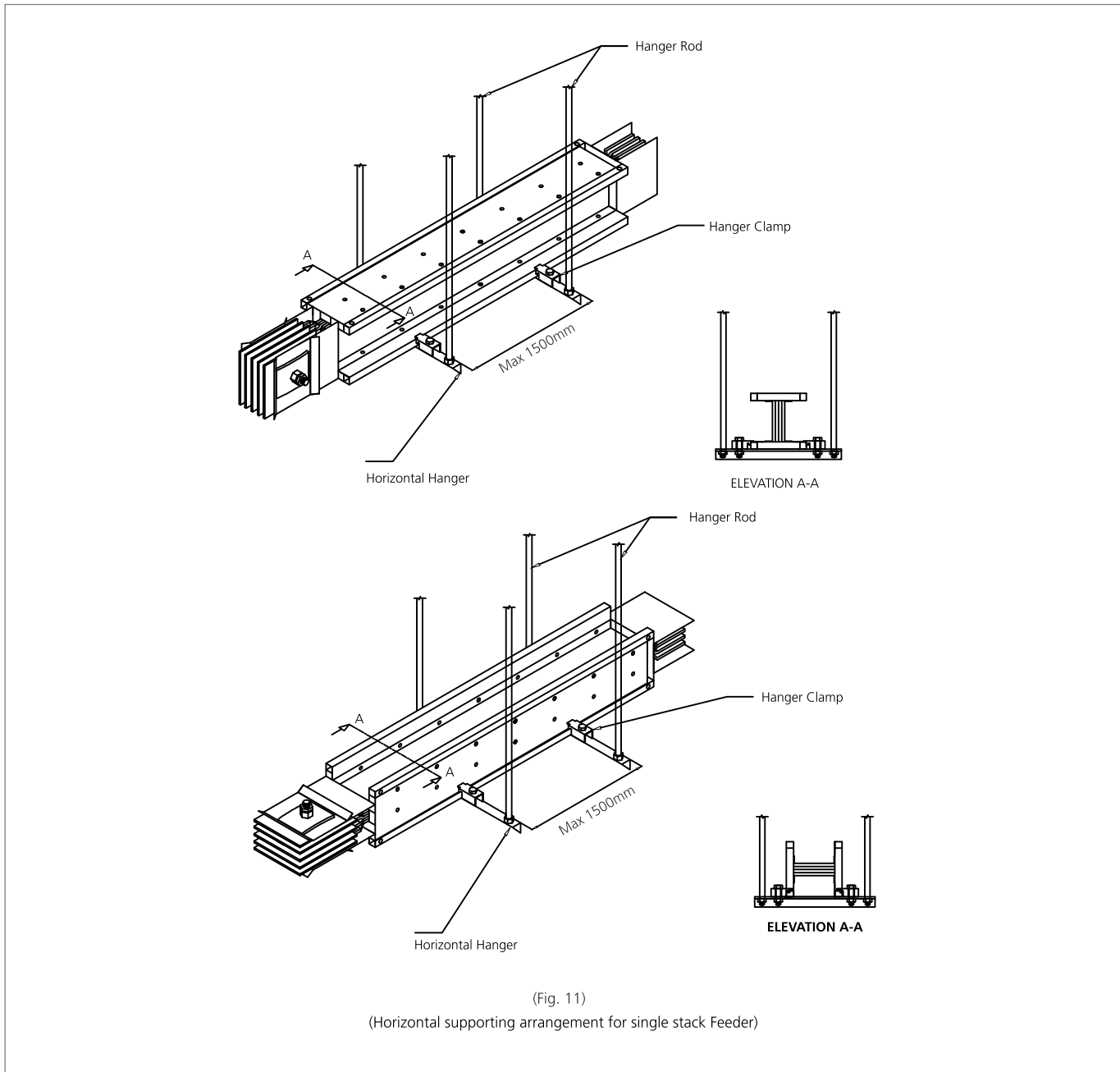

# Installation Guidelines

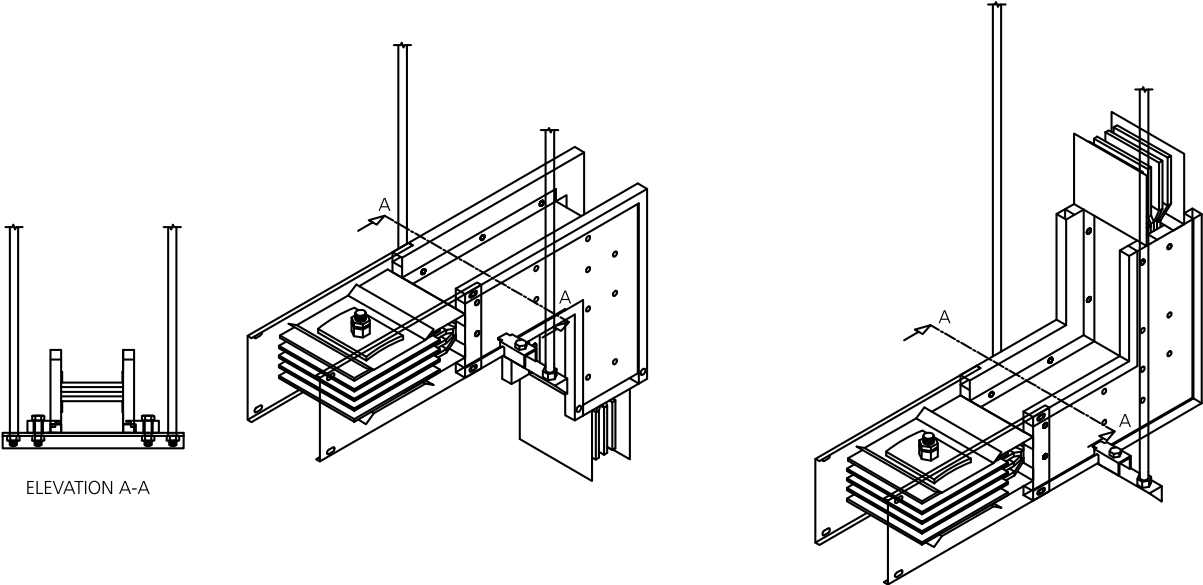

(Fig. 12)  
(Horizontal supporting arrangement for Horizontal Elbow Flatwise installation)

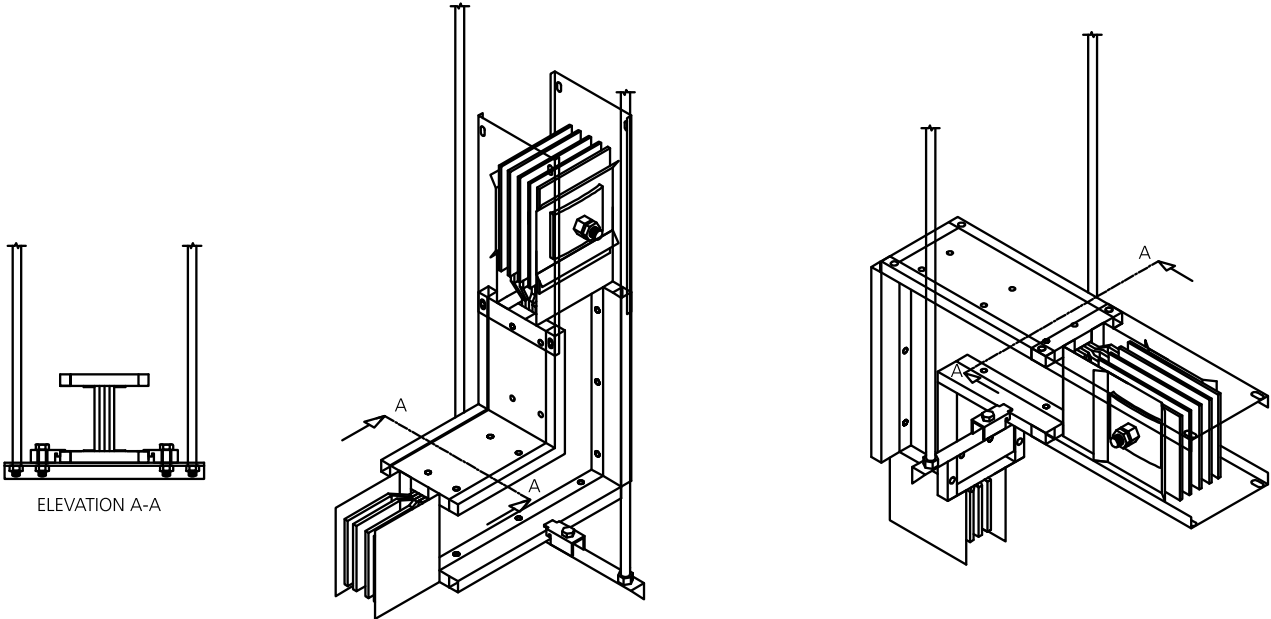

(Fig. 13)  
(Horizontal supporting arrangement for Vertical Elbow Edgewise installation)

## Installation Guidelines

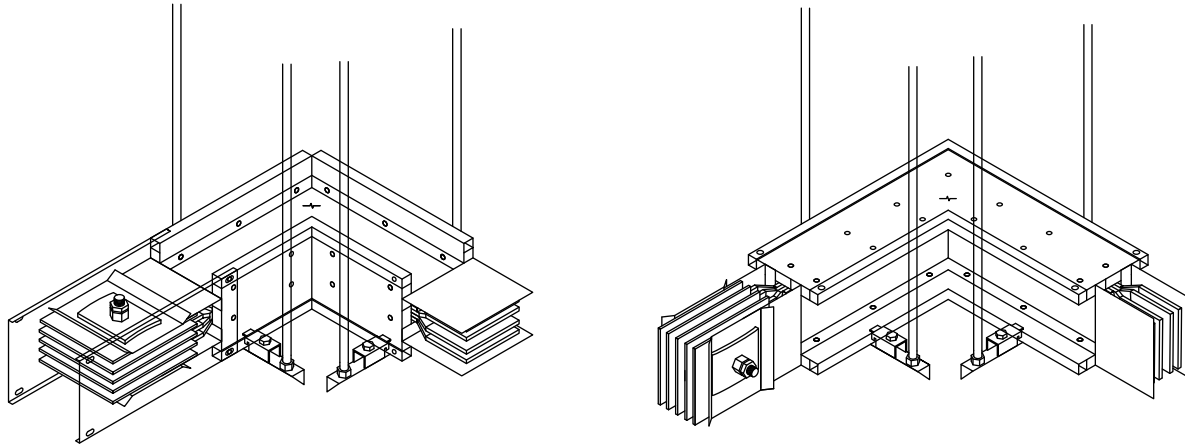

(Fig. 14)

(Horizontal supporting arrangement for Horizontal Elbow Edgewise installation & Vertical Elbow Flatwise installation)

### Wrong Installation Practice

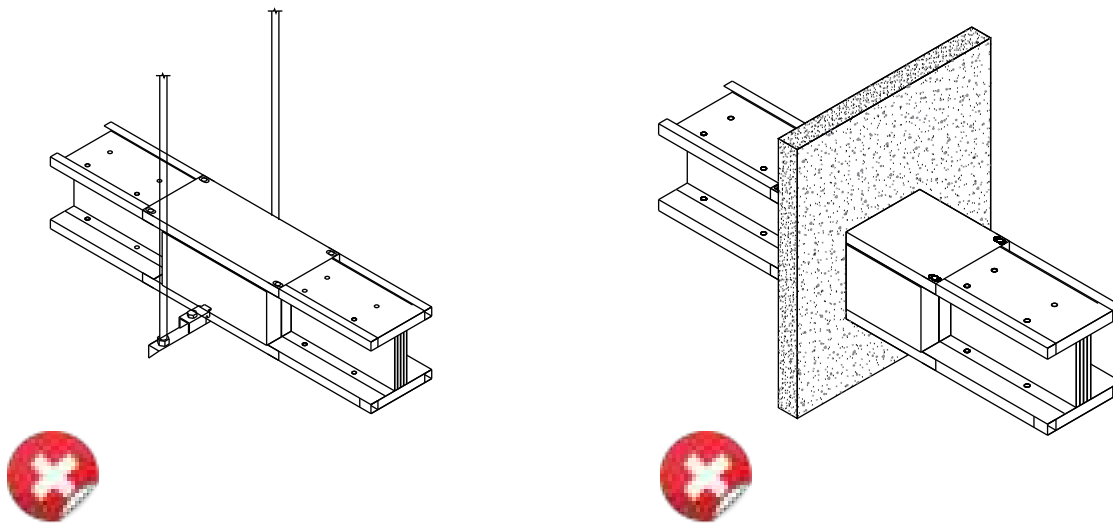

(Fig. 15)

(Hanger support below joint block and wall crossing through joint block)

## 11. Vertical Fix Hanger Installation

Vertical fix hanger should be installed to fix the first feeder, elbows or flanged end unit, on the lowest floor, for firm hold of the busduct.

- 11.1 Temporarily support the busduct section in place. Fit the C-channel onto the floor flange. Fix the bolts onto the slab in order to hold the C-channel firmly to the slab.
- 11.2 Drill the C-channel with an opening hole of  $\text{Ø}14\text{mm}$  to accommodate the fixed support rod. Align the hole with the center line of the side of the busduct housing. The distance in between these two holes from center to center is 90mm [A]. Then drill the busduct housing with an opening hole of  $\text{Ø}12\text{mm}$  with a height of around 190mm [B] from the top of the C-channel to install the L-channel bracket using the M10 bolts supplied. The distance in between these two holes from center to center is 90mm [C].

## Installation Guidelines

11.3 Fix the rod to the top of the C-channel together with the nuts as shown in (1) Try to adjust the top nut on both sides until the height from the top of the C-channel to the base of the L-channel is around 50mm as shown in [D] and it is aligned with the opening hole  $\varnothing 12\text{mm}$  on the busduct housing. Then fix the L-channel together with the nuts. The process of installing the vertical fix hanger is complete.

11.4 Busduct of 2000A or more should have vertical fix hanger support from both front and rear sides.

### 12. Vertical spring hanger installation

Vertical spring hangers are used on subsequent floors to absorb any expansion of the busduct. Moreover, the immediate support should be provided if the floor-to-floor distance exceeds 3 meters.

The following instructions are for fitting of vertical spring hanger for the Henikwon S-Line busduct system.

12.1 Temporarily support the busduct section in place. Fit the C-channel onto the floor flange. Fix the bolts onto the slab in order to hold the C-channel firmly to the slab.

12.2 Drill the C-channel with opening hole of  $\varnothing 14\text{mm}$  to accommodate the fixed support rod. Align the hole with the centerline of the side of the busduct housing. The distance in between these two holes from center to center is 90mm [E]. Then, drill the busduct housing with opening hole of  $\varnothing 12\text{mm}$  with the height around 190mm [F] from the top of the C-channel to install the L-Channel Bracket by using the M10 bolts supplied. The distance in between these two holes from center to center is 90mm [G].

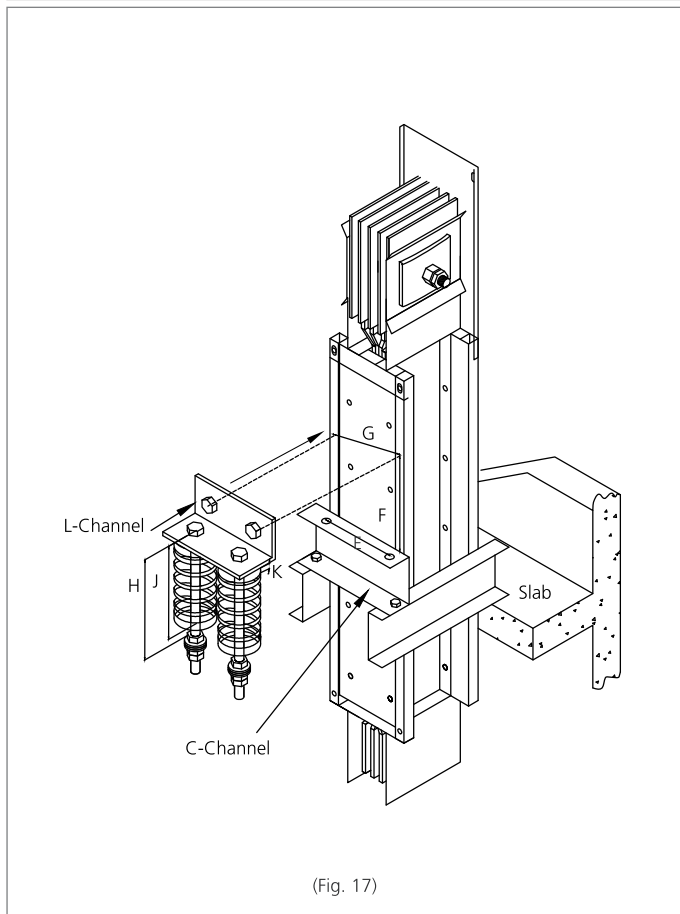
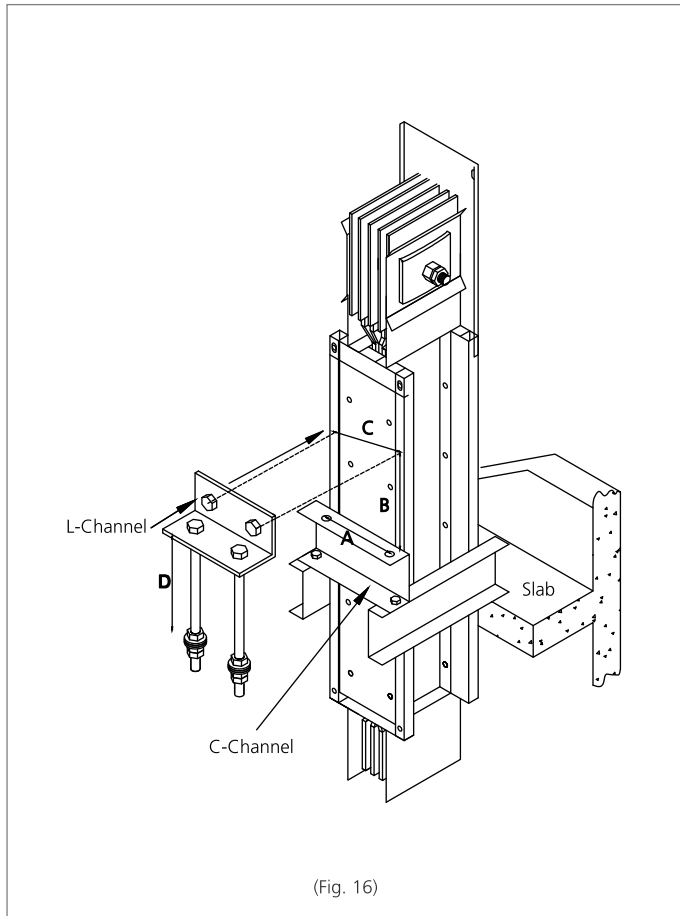

## Installation Guidelines

- 12.3 Fix the rod to the top of the C-Channel together with the nuts. Try to adjust the Top Nut on both sides until the height from the bottom of the L-Channel to the top of the C-Channel is around 155mm as shown in [H] while the height from the bottom of L-Channel to the bracket of the Vertical Spring Hanger is 100mm as shown in [J]. Then, fix the L-Channel together with the nuts as
- 12.4 Unscrew the top nut, 15mm [K] above the top of the L-Channel. The process of installing Vertical Spring Hanger is completed.
- 12.5 Busduct of 2000A or more should have Vertical Spring Hanger support from both front and rear.

### 13. Fixing Plug-in Box

- 13.1 This work shall only be carried out by suitably qualified persons.
- 13.2 Remove the plug-in hole outer cover. (Fig. 18)
- 13.3 Do not remove the plug-in hole mould as removal could expose live busbars.
- 13.4 The orientation of the plug-in hole plate can be verified by visual inspection. The earth bar must be visible through the earth connection opening.
- 13.5 Ensure that the plug-in box isolator is switched off. Remove one bolt from each Z-clamp and rotate 90°.
- 13.6 Align the plug-in box jaw contacts with the plug-in hole plate and push it in fully.
- 13.7 Tighten the plug-in box in position with the four Z-clamps located on the back of the box. Note that the incoming side of the isolator may be live and care should be taken not to displace any internal screens or shrouds.
- 13.8 When the box is secured in place, verify the phasing of the plug-in box before energising the equipment.
- 13.9 For Aluminium Cable termination need to use separate cable entry box as shown in Fig. 19  
Cable box can be mounted at bottom or on side of Plug-in Box
- 13.10 Plug in Box should not be tilted or bent on one side. Ensure wiring is done between PIF and PIB, after installation of PIB with PIF. Continuity of same should be verified after wiring.

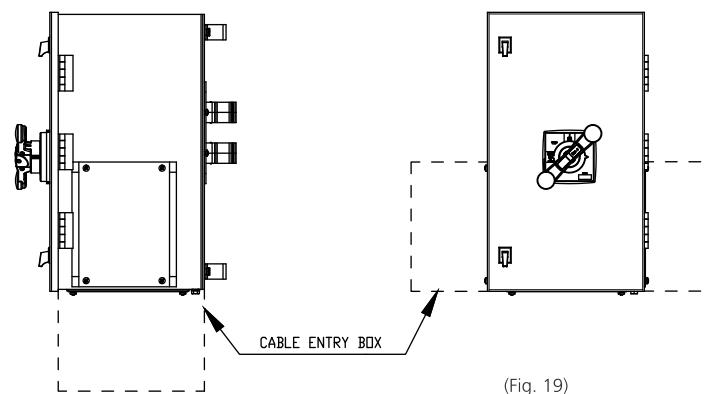
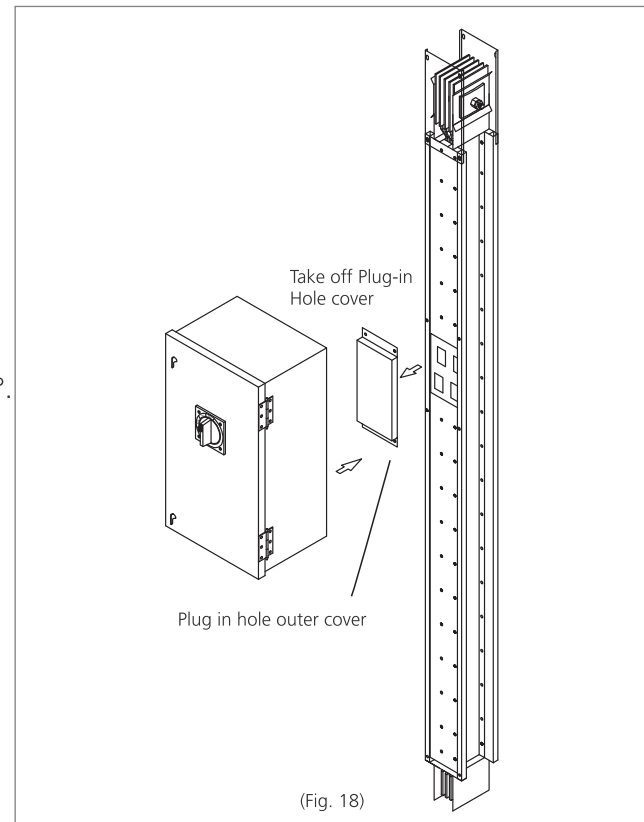

## Installation Guidelines

### 14. Inspection of Joint Bolt

Henikwon S-Line Busduct system uses MF (Maintenance-free) Nut at the jointing section which ensures the proper tightening of the bolt.

- 14.1 Tighten the MF nut with torque wrench
- 14.2 Ensure the tightness of the MF nut until the neck part of MF nuts is broken. If the MF nut is not tightened properly, an overheating of the busduct may occur.
- 14.3 The torque values of tightening of the nuts are as shown below

Conductor	Rating	Tightening Torque
Aluminium	250A to 800A	90 N-m
	1000A to 6300A	150 N-m
Copper	400A to 1250A	90 N-m
	1600A to 6300A	150 N-m

### 15. Energising

#### Before Energising

- 15.1 Recheck all joint connections for tightness by following on the recommended torque value given as Table-2. Ensure that outer head of MF nut is broken. If not, then retighten the nut until it is broken, before installing side cover.
- 15.2 Ensure that upper nut is unscrewed 15mm above the upper part of spring hanger.
- 15.3 Isolate the busduct run by disconnecting all connections to transformers, switchboards, meters and so forth.
- 15.4 Conduct an insulation resistance test on the whole busduct connection after installation. The insulation resistance value cannot be specified due to the difference of the length of the route and the environmental factors. In a dry atmosphere, it would give a value of approximately 100 M $\Omega$  (500V Megger). If the value is less than 10 M $\Omega$ , it has to be checked due to some factors that can reduce the insulation and the other factors can be as follows;
  - a) Whether the busduct is damaged,
  - b) Whether the connecting parts are fixed precisely,
  - c) Whether the bolts for connecting the equipment are securely fastened,
  - d) Whether the hangers are supporting the busduct securely

#### After Energising

When the equipment is energised for the first time, qualified electrical personnel should be present. If short circuits and ground faults caused by damage or poor installation practices have not been detected in the check-out procedure, serious damage can result when the power is turned on.

- 15.5 There should be no electrical load on the busduct when it is energised. Since a busduct typically extends through several rooms and floor levels, care should be taken to see that all devices fed from the busduct are in the OFF position.
- 15.6 The equipment should be energised in sequence by starting at the source end of the system and working toward the load end. In other words, energize the main devices, then the feeder devices and then the branch-circuit devices. Turn the devices to the ON position with a firm positive motion.
- 15.7 After all overcurrent devices have been turned on, loads such as lighting circuits, contractors, heaters, and motors may be turned ON.
- 15.8 When operating properly, the busduct will give off a moderate hum. Excessive noise may be an indication of hardware that has not been tightened or of metal parts that have been improperly assembled.
- 15.9 Occurrence of sparking at any point along the busduct is abnormal. The busduct must be de-energised immediately, and remain de-energised until the sparking condition has been corrected.

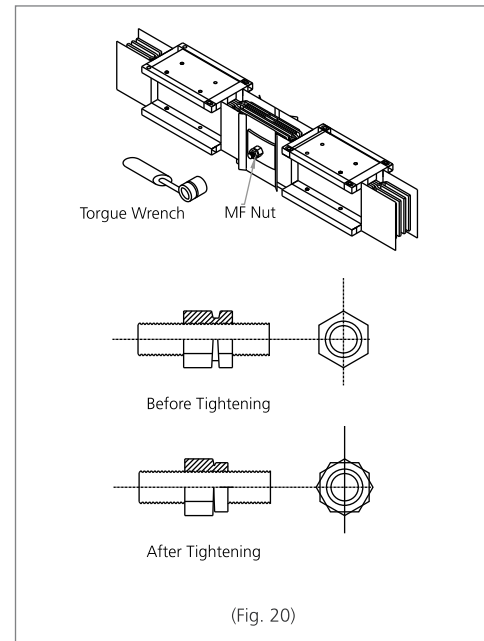

## Installation Guidelines

---

### 16. Care and Maintenance

WARNING: HAZARDOUS VOLTAGES IN ELECTRICAL EQUIPMENT CAN CAUSE SEVERE PERSONAL INJURY OR DEATH. UNLESS OTHERWISE SPECIFIED, INSTALLATION, INSPECTION AND MAINTENANCE SHOULD ONLY BE PERFORMED ON BUSDUCT AND EQUIPMENT TO WHICH **POWER HAS BEEN TURNED OFF, DISCONNECTED AND ELECTRICALLY ISOLATED** SO THAT NO ACCIDENTAL CONTACT CAN BE MADE WITH ENERGISED PARTS. FOLLOW ALL MANUFACTURER'S WARNINGS AND INSTRUCTIONS.

#### Outdoor Busduct

- 16.1 Inspect the busduct once in six months or after any severe electrical short circuit or ground fault.
- 16.2 Perform an infra-red temperature scan on all electrical connections and busduct enclosure while busduct is energized and operating under maximum load conditions. A permanent record should be kept. If readings change with time, deterioration may be taking place and must be corrected.
- 16.3 Turn off power to the busduct
- 16.4 If there is appreciable accumulation of dust and dirt, clean it off by using a brush, vacuum cleaner, or clean lint-free rags. In order to avoid blowing dust into busduct joints, circuit breakers, or other equipment, do not use a blower or compressed air. Ensure that all drain holes are operating properly.
- 16.5 Check the insulation resistance prior to re-energising the busduct. A permanent record should be kept of resistance readings. If readings decrease appreciably with time, deterioration is taking place and must be corrected. (Contact the manufacturer)

#### Indoor Busduct

- 16.6 Inspect the busduct once in six months or after any severe electrical short circuit or ground fault.
- 16.7 Perform an infra-red temperature scan on all electrical connections and busduct enclosure while busduct is energized and operating under maximum load conditions. A permanent record should be kept. If readings change with time, deterioration may be taking place and must be corrected.
- 16.8 Turn off power to the busduct.
- 16.9 Look for any moisture or signs of previous wetness or dripping onto the busduct or onto connection boxes from leaky roofs, pipes, sprinklers or other sources of moisture. Look for any recent changes in sprinklers or other plumbing that might now be a source of trouble to the busduct.
- 16.10 Seal off any cracks or openings which have allowed moisture to enter the busduct or its connection boxes. Eliminate source of any dripping onto the busduct and any other source of moisture. See SECTION 6 for more specific details on preventing liquid from getting onto the busduct.
- 16.11 Replace or thoroughly dry and clean any insulating material which is damp or wet or shows accumulation of deposited material from previous wettings.
- 16.12 If there is appreciable accumulation of dust, clean it off by using a brush, vacuum cleaner, or clean lint-free rags. In order to avoid blowing dust into busduct joints, circuit breakers, or other equipment, do not use a blower or compressed air.
- 16.13 Carefully inspect all visible electrical joints and terminals.
- 16.14 Visually check connections to be certain that they are clean and secure. Loose and/or contaminated connections increase electrical resistance which can cause overheating. Such overheating is indicated by discoloration or flaking of insulation and/or metal parts. Pitting or melting of connecting surfaces is a sign of arcing due to a loose or otherwise poor connection. Parts which show evidence of overheating or looseness should be cleaned or replaced if damaged, contact manufacturer before re-torquing joint bolts.
- 16.15 Check the insulation resistance prior to re-energizing the busduct. A permanent record should be kept of resistance readings. If readings decrease appreciably with time, deterioration is taking place and must be corrected. (Contact the manufacturer). Also, refer to Section 14.4.
- 16.16 Indication should be provided to prohibit entry of unauthorized people in electrical shaft. Furthermore, All Shaft should be closed by door and locked to avoid entry of unauthorized people.

# Installation Guidelines

## 17. Final Site Measurement

### 17.1 Method for Feeder Busduct

Formula as below,

$$a = A - 125\text{mm} - 125\text{mm}$$

Example, A = 800mm

$$a = 800\text{mm} - 125\text{mm} - 125\text{mm}$$

$$a = 550\text{mm}$$

The Order should be, Feeder Busduct of 550mm

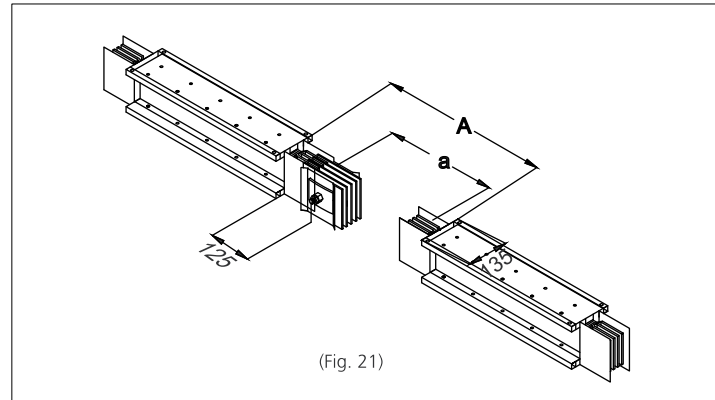

### 17.2 Method for Horizontal Elbow

Formula as below,

$$a = A - 125\text{mm} - 67.5\text{mm}$$

$$b = B - 125\text{mm} - 67.5\text{mm}$$

Example, A = 500mm, B = 600mm

$$a = 500\text{mm} - 125\text{mm} - 67.5\text{mm}$$

$$a = 307.5\text{mm}$$

$$b = 600\text{mm} - 125\text{mm} - 67.5\text{mm}$$

$$b = 407.5\text{mm}$$

The Order should be, Horizontal Elbow of 308 x 408mm

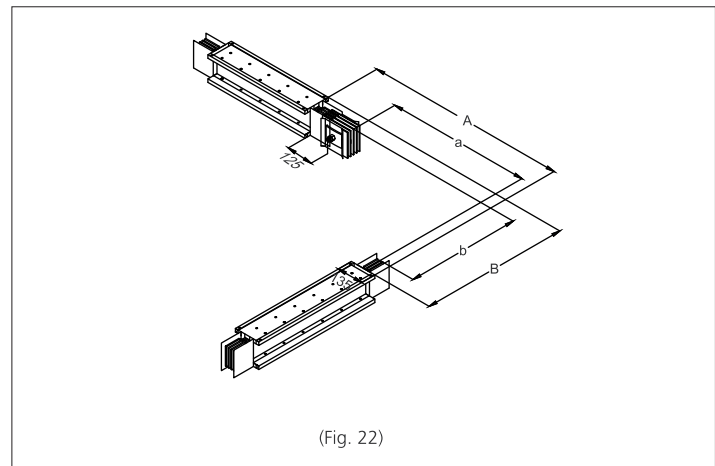

### 17.3 Method for Vertical Elbow

Formula as below,

$$a = A - 125 - C/2$$

$$b = B - 125 - C/2$$

Example:

A=800mm, B=1000mm, C=180mm

$$a = 800 - 125 - 180/2$$

$$a = 585\text{mm}$$

$$b = 1000 - 125 - 180/2$$

$$b = 785\text{mm}$$

The order should be, Vertical elbow of 585 x 785mm

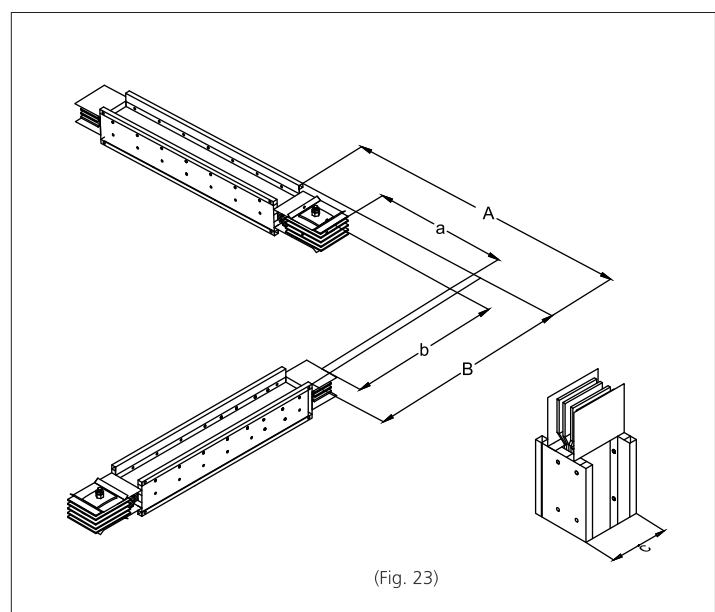

# Installation Guidelines

## 18. Fault Finding

Item	Symptom	Possible Causes	Possible Remedies
1	Busduct temperature rise is more than 95°C	<ol style="list-style-type: none"> <li>1. The torque level at busduct joint is not sufficient</li> <li>2. Alignment of busduct route is not proper</li> <li>3. Insufficient supporting arrangement</li> </ol>	<ol style="list-style-type: none"> <li>1. Re-tighten all the busduct joints at required torque setting</li> <li>2. Check alignment with Level gauge / Spirit level and ensure complete Busduct length is aligned</li> <li>3. Provide the supports as per manufacturer guideline</li> </ol>
2	Humming sound	The earth bar not properly tightened to the busduct housing	Re-tighten a bolt & nut for the earth bars.
3	Megger test failed	<ol style="list-style-type: none"> <li>1. There might be dripping of water or foreign particles trapped in the joints / insulation material</li> <li>2. The joint insulator was not properly installed.</li> <li>3. Insulation got damaged during installation</li> </ol>	<ol style="list-style-type: none"> <li>1. Re-tighten a bolt &amp; nut for the earth bars.</li> <li>2. Check the joint assembly and torque level.</li> <li>3. Contact E&amp;A representative</li> </ol>

**Caution:**

Always remember to isolate the electrical power supply and/or disconnect with other electrical equipment if necessary before conducting the repairing work.



**HENIKWON S-LINE BUSDUCT SYSTEM**  
 Final Insulation Test Report  
 (Before Energisation)

**APPENDIX 2**

Project Name: \_\_\_\_\_ Date: \_\_\_\_\_  
 Busduct Rating: \_\_\_\_\_ Route Name: \_\_\_\_\_  
 Total Length of Route: \_\_\_\_\_ Meters Busduct Type: AL / Cu Enclosure: GI / AL  
 Configuration: 3P3W / 3P3W+50%E / 3P4W / 3P4W+50%E / 3P4W(50%N) / 3P4W(50%N)+50%E

Phase	Insulation Resistance (M-Ohm)
R-E	
Y-E	
B-E	
N-E	
R-Y	
R-B	
R-N	
Y-B	
Y-N	
B-N	

Tested By: \_\_\_\_\_ Date: \_\_\_\_\_

Witnessed By: \_\_\_\_\_

**HENIKWON S-LINE BUSDUCT SYSTEM**  
Pre-commissioning Checklist  
(Before Energization)

**APPENDIX 3**

Project Name: \_\_\_\_\_ Date: \_\_\_\_\_

Sr. No.	Description	Result / Observation
1	Check the physical appearance of Wooden Box, there should be no damage visible outside	<input type="checkbox"/> OK <input type="checkbox"/> Not OK
2	Check and record the physical appearance of busduct (stickers, paint, shape), there should be no damage visible outside	<input type="checkbox"/> OK <input type="checkbox"/> Not OK
3	If any unit is kept unused, ensure the proper storage of the same	<input type="checkbox"/> Yes <input type="checkbox"/> No
4	Megger value of each element found more than 500M-Ohm @500V megger before installation	<input type="checkbox"/> Yes <input type="checkbox"/> No
5	Busduct are installed as per approved drawings and direction labels are strictly followed for installation	<input type="checkbox"/> Yes <input type="checkbox"/> No
6	Busduct distances from beams, ceiling and other ducts is maintained as per guidelines	<input type="checkbox"/> Yes <input type="checkbox"/> No
7	Busduct are installed above the water splashing system	<input type="checkbox"/> Yes <input type="checkbox"/> No
8	Distance between two adjacent hangers/clips is maximum 1.5Mtr. Extra hangers in between are acceptable however ensure Hanger is not coming in the joint section	<input type="checkbox"/> Yes <input type="checkbox"/> No <input type="checkbox"/> NA
9	Additional supports are given at each Bend irrespective of the above mentioned supports	<input type="checkbox"/> Yes <input type="checkbox"/> No <input type="checkbox"/> NA
10	Sufficient fixed support/hangers are located along the riser busduct based on the standard distance of 3 Metre each	<input type="checkbox"/> Yes <input type="checkbox"/> No <input type="checkbox"/> NA
11	No joints are installed inside the wall or floor slab and minimum distance from Wall/Ceiling is maintained as per guidelines	<input type="checkbox"/> Yes <input type="checkbox"/> No <input type="checkbox"/> NA
12	All the bolts (of Joint block, Joint Covers, Termination) are tightened to recommended torque values (Joint tightness value should be 90Nm for 250A & 800A in AL Busduct & 400A to 1250A Cu Busduct; and 150Nm for 1000A to 6300A in AL Busduct & 1600A to 6300A in Cu Busduct)	<input type="checkbox"/> Yes <input type="checkbox"/> No
13	Maintenance Free Nut is broken, Lock Nut is formed and Red marking done at Nut Side	<input type="checkbox"/> Yes <input type="checkbox"/> No
14	All the Joint Covers are tightened to recommended torque values with M6 hardware	<input type="checkbox"/> Yes <input type="checkbox"/> No
15	Flange End is not disturbed or extra bend is not done at site	<input type="checkbox"/> Yes <input type="checkbox"/> No
16	All the hardware's are fixed at Support plate of terminal end	<input type="checkbox"/> Yes <input type="checkbox"/> No
17	Plug-in boxes / Tap-off boxes are as per approved drawings, switchgear rating & makes	<input type="checkbox"/> Yes <input type="checkbox"/> No <input type="checkbox"/> NA
18	There is no gap between PIB and PIF after assembly and PIB Z-bracket is engaged with PIB and hardware's are tightened	<input type="checkbox"/> Yes <input type="checkbox"/> No <input type="checkbox"/> NA
19	Ensure wiring is done between PIF and PIB, after installation of PIB with PIF. Continuity of same should be verified after wiring	<input type="checkbox"/> Yes <input type="checkbox"/> No
20	Alignment of Busduct routes is verified using Water level or Thread line or Level indicator and Riser routes by using Plumb line	<input type="checkbox"/> Yes <input type="checkbox"/> No
21	Sealant supplied by manufacturer is applied alongside joint area for all IP66 joint blocks	<input type="checkbox"/> Yes <input type="checkbox"/> No
22	Entire busduct route is covered with Canopy for outdoor installation	<input type="checkbox"/> Yes <input type="checkbox"/> No
23	Ensure that there is no water spilled on the busduct	
24	All the shorting links/Equaliser link (at Flange End) removed for Megger. If PIB/TOB is installed, keep Circuit breaker in Off position	<input type="checkbox"/> Yes <input type="checkbox"/> No
25	Minimum megger value of each route found more than 10M-Ohm @500V megger before charging	<input type="checkbox"/> Yes <input type="checkbox"/> No

Tested By: \_\_\_\_\_ Date: \_\_\_\_\_

Witnessed By: \_\_\_\_\_

## Electrical Standard Products (ESP) Offices:

### HEAD OFFICE

L&T Electrical & Automation  
TC-II, Tower B, Prima Bay,  
Gate No. 5, Saki Vihar Road, Powai,  
**MUMBAI - 400072.**  
Tel: 022-67052874 / 2737 / 1156  
e-mail: cic@Lntebg.com

### BRANCH OFFICES

L&T Electrical & Automation  
C-201, The First Commercial Complex,  
B/S Keshavbaug Party Plot, Vastrapur,  
**Ahmedabad - 380015**  
Toll Free: 1800 233 5858 / 1800 200 5858  
e-mail: CIC@Lntebg.com

L&T Electrical & Automation  
Wework Central, #36 Infantry Road,  
**Bengaluru - 560 001**  
Toll Free: 1800 233 5858 / 1800 200 5858  
e-mail: CIC@Lntebg.com

L&T Electrical & Automation  
Under O Launchpad, 4th floor,  
Unit-434, Esplanade 1, Rasulgurh,  
**Bhubaneswar - 751010**  
Toll Free: 1800 233 5858 / 1800 200 5858  
e-mail: CIC@Lntebg.com

L&T Electrical & Automation  
4th floor, SCO-54,55,56,  
Sector -17A  
**Chandigarh - 160017**  
Toll Free: 1800 233 5858 / 1800 200 5858  
e-mail: CIC@Lntebg.com

L&T Electrical & Automation  
Olympia Technology Park,  
10th Floor, CITIUS A Block,  
Plot No. 1, Phase 1, Guindy,  
**Chennai - 600032**  
Toll Free: 1800 233 5858 / 1800 200 5858  
e-mail: CIC@Lntebg.com

L&T Electrical & Automation  
Playworkz Coworking Space  
43 & 44, 3rd Cross,  
Bharathy Colony, Peelamedu,  
**Coimbatore - 641004**  
Toll Free: 1800 233 5858 / 1800 200 5858  
e-mail: CIC@Lntebg.com

L&T Electrical & Automation  
3rd Floor, 1&2 Vijay Park,  
Main Chakrata Road, Opp. Anandam  
Near Ballapur chowk,  
**Dehradun - 248001**  
Toll Free: 1800 233 5858 / 1800 200 5858  
e-mail: CIC@Lntebg.com

L&T Electrical & Automation  
Ground Floor, B-27, Biplab Rashbihari Sarani,  
Sector 2A, Bidhan Nagar,  
**Durgapur - 713212**  
Toll Free: 1800 233 5858 / 1800 200 5858  
e-mail: CIC@Lntebg.com

L&T Electrical & Automation  
6th floor, Exotica Greens, A Block, 191,  
R G Baruah Road, Guwahati Central,  
**Guwahati - 781005**  
Toll Free: 1800 233 5858 / 1800 200 5858  
e-mail: CIC@Lntebg.com

L&T Electrical & Automation  
Shri Daneshwari, 1st Floor,  
Plot No. 17, 2nd Cross,  
Near Old Income Tax Office Road,  
Vidyanagar,  
**Hubballi - 580021**  
Toll Free: 1800 233 5858 / 1800 200 5858  
e-mail: CIC@Lntebg.com

L&T Electrical & Automation  
AWFIS space solutions, Prestige Phoenix,  
4th floor, 1405, Umanagar, Begumpet,  
**Hyderabad - 500016**  
Toll Free: 1800 233 5858 / 1800 200 5858  
e-mail: CIC@Lntebg.com

L&T Electrical & Automation  
Workie, 214 - 2nd Floor,  
Apollo Premier, PU-4,  
Scheme No. 54,  
Vijay Nagar Square,  
**Indore - 452010**  
Toll Free: 1800 233 5858 / 1800 200 5858  
e-mail: CIC@Lntebg.com

L&T Electrical & Automation  
Office No 430, 4th floor,  
Jaipur Electronic Market  
Riddhi Siddhi,  
Gopalpura Bypass,  
**Jaipur - 302018**  
Toll Free: 1800 233 5858 / 1800 200 5858  
e-mail: CIC@Lntebg.com

L&T Electrical & Automation  
GDR Siddha, Ground Floor, N Road  
Bistupur, Opposite St. Mary's Church,  
**Jamshedpur - 831001**  
Toll Free: 1800 233 5858 / 1800 200 5858  
e-mail: CIC@Lntebg.com

L&T Electrical & Automation  
Business Communication Centre  
2nd Floor, Chiramel Chambers,  
Kurisipally Road,  
Ravipuram,  
**Kochi - 682 015**  
Toll Free: 1800 233 5858 / 1800 200 5858  
e-mail: CIC@Lntebg.com

L&T Electrical & Automation  
2nd Floor, BN3, Salt Lake, Sector-V,  
**Kolkata - 700091**  
Toll Free: 1800 233 5858 / 1800 200 5858  
e-mail: CIC@Lntebg.com

L&T Electrical & Automation  
No. 10, Fortuna Towers, 2nd floor,  
Rana Pratap Marg, Near NBRI  
**Lucknow - 226001**  
Toll Free: 1800 233 5858 / 1800 200 5858  
e-mail: CIC@Lntebg.com

L&T Electrical & Automation  
El Dorado Building 3rd Floor,  
6, Venkatraman Street,  
Chinna Chokkikulam  
**Madurai - 625 002**  
Toll Free: 1800 233 5858 / 1800 200 5858  
e-mail: CIC@Lntebg.com

L&T Electrical & Automation  
TC II, Tower B, PRIMA BAY  
Gate no. 5, Saki Vihar Road Powai,  
**Mumbai - 400072**  
Toll Free: 1800 233 5858 / 1800 200 5858  
e-mail: CIC@Lntebg.com

L&T Electrical & Automation  
Unnati Building, 2nd floor,  
Automation Campus, A-600, TTC Industrial area  
Shil-Mahape road, Mahape  
**Navi Mumbai - 400710**  
Toll Free: 1800 233 5858 / 1800 200 5858  
e-mail: CIC@Lntebg.com

L&T Electrical & Automation  
M1 & M2, Mezzanine Floor,  
Himalaya Excellency, Plot No- C - 47,  
Pratap Nagar Square,  
**Nagpur - 440022**  
Toll Free: 1800 233 5858 / 1800 200 5858  
e-mail: CIC@Lntebg.com

L&T Electrical & Automation  
A-25, 1st Floor, Imperia Complex,  
Moham Corporate Industrial Estate,  
Near Sarita Vihar Metro Station,  
Mathura Road,  
**New Delhi - 110044**  
Toll Free: 1800 233 5858 / 1800 200 5858  
e-mail: CIC@Lntebg.com

L&T Electrical & Automation  
A06/A07, Second Floor,  
Grand Chandra complex, Frazer road  
**Patna - 800001**  
Toll Free: 1800 233 5858 / 1800 200 5858  
e-mail: CIC@Lntebg.com

L&T Electrical & Automation  
UrbanWrk, 5th Floor, Sai Radhe,  
Raja Bahadur Mill road, Behind Hotel  
Grand Sheraton, Sangamwadi  
**Pune - 411001**  
Toll Free: 1800 233 5858 / 1800 200 5858  
e-mail: CIC@Lntebg.com

L&T Electrical & Automation  
Unit No. 207, 2nd Floor, Wallfort Ozone,  
Raipur Road, Near Fafadih Chowk,  
**Raipur - 492001**  
Toll Free: 1800 233 5858 / 1800 200 5858  
e-mail: CIC@Lntebg.com

L&T Electrical & Automation  
10th Floor, Titaanium Business,  
Bhimrad Road, Althan  
**Surat - 395017**  
Toll Free: 1800 233 5858 / 1800 200 5858  
e-mail: CIC@Lntebg.com

L&T Electrical & Automation  
11th Floor, Block-D, Notus IT Park,  
Sarabhai Campus, Bhailal Amin Marg,  
**Vadodara - 390023**  
Toll Free: 1800 233 5858 / 1800 200 5858  
e-mail: CIC@Lntebg.com

L&T Electrical & Automation  
414, 4th Floor, Naga Chambers,  
Opposite HDFC Bank  
Ram Nagar, Waltair Main Road  
**Visakhapatnam - 530002**  
Toll Free: 1800 233 5858 / 1800 200 5858  
e-mail: CIC@Lntebg.com

Product improvement is a continuous process, For the latest information and special application, please contact any of our offices listed here.  
Product photographs shown for representative purpose only.



L&T Electrical & Automation, Electrical Standard Products  
TC-II, Tower B, Prima Bay, 3rd Floor, Gate No. 5, Saki Vihar Road, Powai,  
Mumbai - 400 072, INDIA. Web: www.Lntebg.com

Customer Interaction Centre (CIC)  
BSNL/MTNL (toll-free): 1800 233 5858 Reliance (toll-free): 1800 200 5858  
Tel: 022 6774 5858 Email:cic@Lntebg.com Web: www.Lntebg.com