



PASSION FOR POWER.

 made in **GERMANY**  
since 1931



# INTERNATIONAL CATALOGUE No. 17

## Highest quality for the highest requirements

Since 1931 HENSEL has been developing and manufacturing innovative solutions for electrical equipment in buildings. Electrical installation and distribution systems made of high quality thermoplastic are used today because of their special properties in areas where dust and humidity place high demands on the electrical installation.



Headquarters in Germany

## Subsidiaries abroad

### Czech Republic

Hensel s.r.o.  
[www.hensel.cz](http://www.hensel.cz)

### Hungary

Hensel Hungaria Villamosági Kft.  
[www.hensel.hu](http://www.hensel.hu)

### Poland

Hensel Polska Sp. z o. o.  
[www.hensel-electric.pl](http://www.hensel-electric.pl)

### Russia

OOO Hensel + Mennekes Elektro  
[www.hensel-electric.ru](http://www.hensel-electric.ru)

### India

Hensel Electric India Pvt. Ltd  
[www.hensel.in](http://www.hensel.in)

### Turkey

Hensel Electric Turkey Ltd.  
[www.hensel-electric.com.tr](http://www.hensel-electric.com.tr)

### People's Republic of China

Hensel (Qingdao)  
Electrical Installation and  
Distribution Systems Co. Ltd  
[www.hensel-electric.cn](http://www.hensel-electric.cn)

### United Arab Emirates

Hensel Electric FZE  
[www.hensel-electric.ae](http://www.hensel-electric.ae)

## Representations abroad

### Africa

Angola  
Egypt  
Mozambique  
Republic of Mauritius  
South Africa

### America

USA

### Asia

Bangladesh  
Bhutan  
China  
India  
Indonesia  
Japan  
Kazakhstan  
Malaysia  
Maldives  
Myanmar  
Pakistan  
Philippines  
Singapore  
Sri Lanka  
Taiwan

Thailand  
Vietnam

### Europe

Albania  
Austria  
Belgium  
Bosnia-Herzegovina  
Bulgaria  
Croatia  
Czech Republic  
Denmark  
Estonia  
Finland  
France  
Great Britain  
Hungary  
Iceland  
Ireland  
Israel  
Italy  
Latvia  
Lithuania  
Luxembourg  
Macedonia  
Montenegro

Netherlands  
Norway  
Poland  
Portugal  
Romania  
Russia  
Serbia  
Slovakia  
Slovenia  
Spain  
Sweden  
Switzerland  
Turkey  
Ukraine

### Middle East

United Arab Emirates  
Bahrain  
Iran  
Kuwait  
Oman  
Qatar  
Saudi Arabia

### Oceania

Australia  
New Zealand

# Contents

## ENYCASE®

**DK Cable junction boxes**  
1.5 up to 240 mm<sup>2</sup>



8 - 141

## ENYBOARD

**KV Small-type distribution boards**  
3 - 54 modules



142 - 223

## ENYSTAR®

**Distribution boards with door**  
up to 250 A



224 - 297

## ENYMOD

**Mi Power distribution boards**  
up to 630 A



298 - 373

## ENYFLEX

**Empty enclosures**  
in accordance with IEC 62208  
for customized solutions and individual applications



374 - 397

## ENYFIT

**Cable entry systems**



398 - 421

**Technical details**

422 - 439

**Types**

440 - 448

# Leading through innovation and quality



The Gustav Hensel GmbH & Co. KG is a leading company specialising in the manufacture of innovative electrical installation and power distribution systems for facility equipment of buildings. Founded in 1931, Hensel today represents a company group which is active worldwide and has about 820 employees, 550 of which are in Germany.

In addition to the parent company in Lennestadt, Germany, subsidiaries and representatives in important foreign markets ensure a continually strong international presence.



Wherever environmental influences, dust and humidity require a particularly sophisticated installation technology, Hensel with its innovative solutions enables the reliable and safe distribution of energy.

The range of modern electrical installation and power distribution systems for national and international applications has made Hensel into one of the market leaders in the distribution of electrical energy in the low voltage sector.

## State of the art technology, clever logistics

- State-of-the-art and automated plastic injection-molding machinery at two sites
- Advanced manufacturing processes used in metal processing and surface coating
- Highly qualified employees and a modern machinery guarantee state-of-the-art injection mould and metal working tools
- Coordination and control of all logistics and storage processes, shipping all over the world

## Internationally represented

### Subsidiaries abroad:

- Czech Republic, Hungary, Poland, People's Republic of China, India, Turkey, Russia, United Arab Emirates
- Partners in more than 60 countries

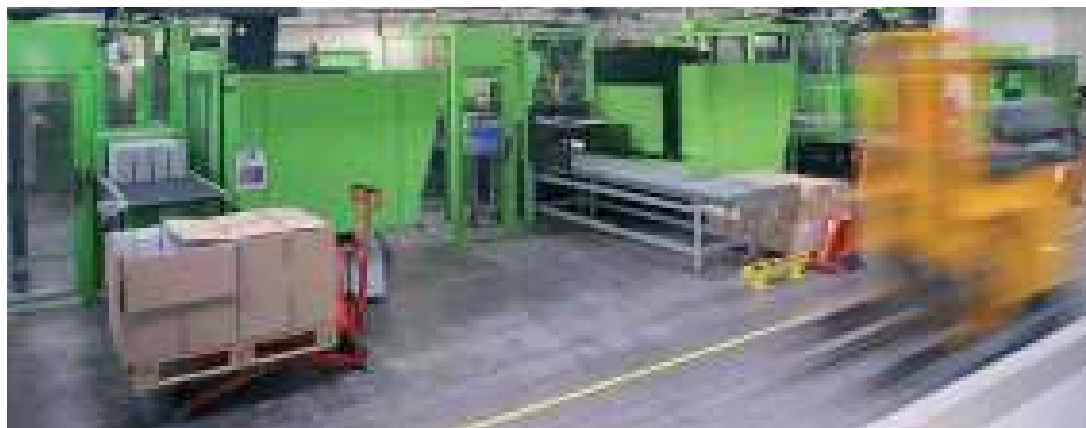

# Electrotechnical products of highest quality and reliability

Wherever dusty and humid environmental conditions place high demands on the electrical installation, products of highest quality conforming to standards are required for a reliable and safe distribution of electrical energy in the low voltage sector.



High quality standards guarantee our customers' competitive advantage in the future.

All Hensel production facilities are certified and meet the requirements of **DIN EN ISO 9001:2008**

Internal quality management

- Advanced test methods

## Hensel stands for tested quality

- Durability of plastic materials
- Short-circuit withstand capability
- Tests on electromagnetic susceptibility (EMC tests)
- Fire behaviour
- Limits of temperature rise
- Functional tests
- IP degree of protection (dust and water protection)
- Impact resistance
- Temperature resistance
- Corrosion-proof
- Dimensions check via structured light projection



## Areas of application

Hensel products guarantee safety in

- Agriculture and farming
- Automotive industries
- Banks and insurance offices
- Cement factories
- Coldstorage facilities
- Gas stations and pipelines
- Hospitals and clinics
- Hotels and cinema complexes
- Industrial, commercial and company buildings
- Leisure and commercial centres (Malls)
- Marine environments
- Metal, wood and paper processors
- Mining
- Photovoltaic plants
- Power stations
- Residential and non-residential buildings
- Schools and universities
- Stadia and sport centres
- Telecommunications
- Traffic infrastructure buildings
- Tunnels and road construction
- Water and waste water treatment plants



 made in **GERMANY**  
since 1931

## Hensel APP

Download our free Hensel APP and be always up to date.  
Available in the Google Play Store and the official Apple iTunes store .

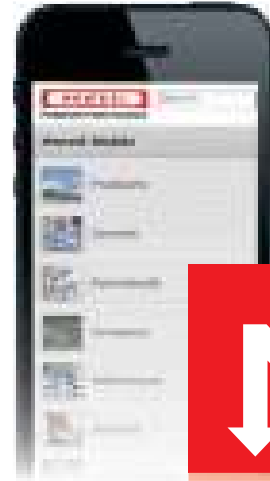

## Videos

Discover our mounting videos, product benefits and manuals for our products in brief, informative spots on [youtube.com/henselectric](https://www.youtube.com/henselectric)

Learn more about our company  
at our promotional video!



## Downloads

On our download portal we offer various catalogs,  
product information and informational materials.

## Social Media



Hensel News on Facebook!  
[facebook.com/henselectric](https://www.facebook.com/henselectric)



Follow us on Twitter!  
[twitter.com/henselectric](https://www.twitter.com/henselectric)



Hensel videos on YouTube!  
[youtube.com/henselectric](https://www.youtube.com/henselectric)



# www.hensel-electric.de

## Exhibitions

International and national



## Planning aids

- Planning software

**ENYGUIDE**

[www.enyguide.eu](http://www.enyguide.eu)

- **Portal I61439**

Support platform for distribution technology keeps new IEC 61439 standard under control at [www.hensel-electric.de/61439](http://www.hensel-electric.de/61439)

- Guide for design and assembly of distribution boards up to 630 A according to IEC 61439 / EN 61439

## Your specialist partner

Quick support for acute problems on-site



## Trainings

Highly qualified lecturers, modern seminar and training rooms and the latest presentation techniques.



## Customized solutions

- Enclosures on customer request for individual applications
- Individual solutions that comply to standards



## Mobile exhibitions

Mobile exhibitions on system solutions and new developments internationally and nationally



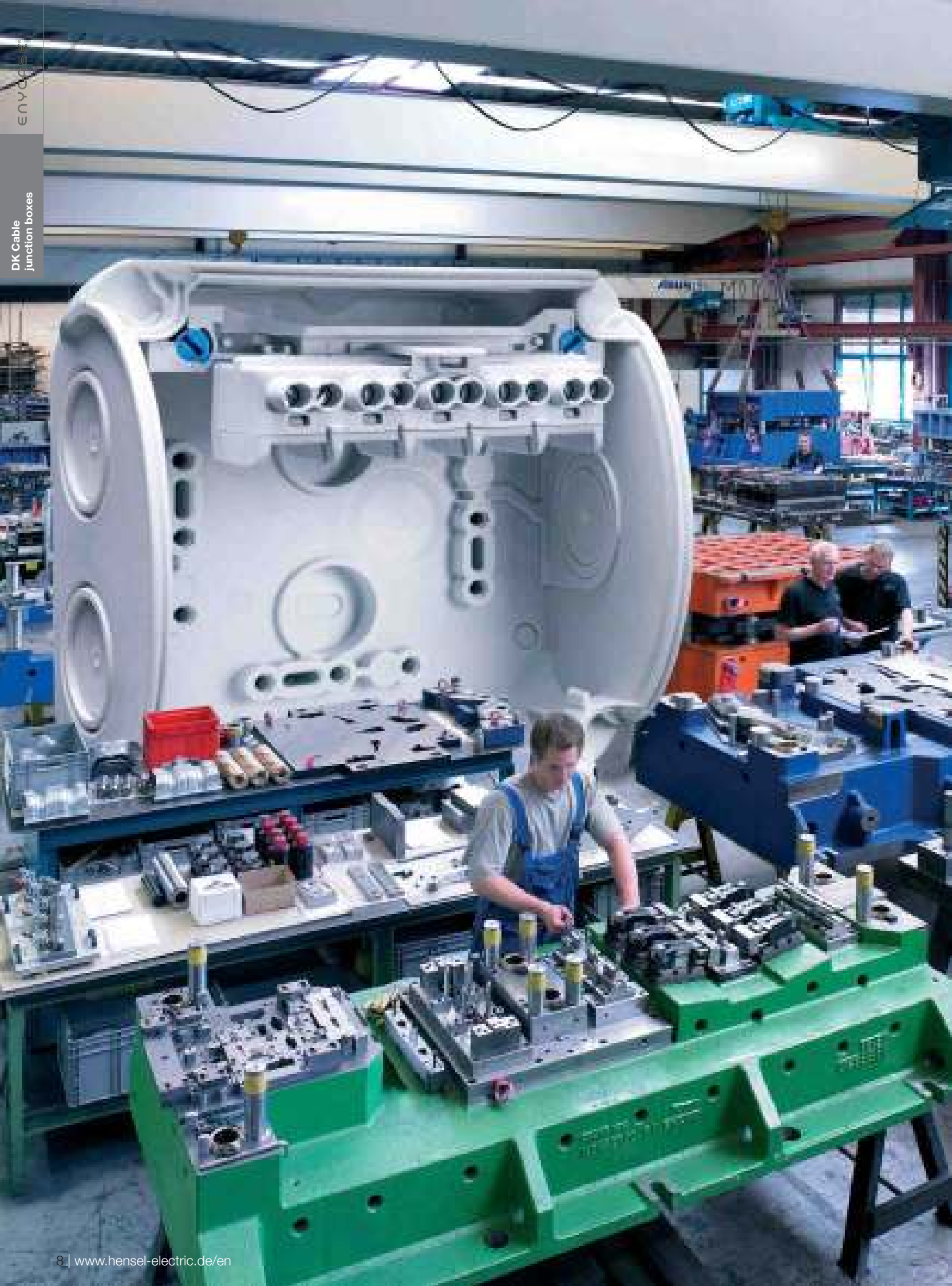



## DK Cable junction boxes

- 1.5 mm<sup>2</sup> up to 240 mm<sup>2</sup>
- degree of protection IP 54-69
- in accordance with IEC 60670-22

Product benefits and reference tables	10-15
Selection table for cable junction boxes	16-17
<b>For normal environment and protected outdoor</b>	
With terminals	18-26
Without terminals	27-28
With terminals for aluminum and copper conductors	29-35
For safety lighting circuits	36-39
For equipotential bonding conductors	40
With main line branch terminals for copper conductors	41-43
With terminal blocks for aluminum- and copper conductors	44-48
<b>"Weatherproof", for outdoor installation</b>	49-74
Cable entry via metric knockouts, with or without terminals	49-67
Box walls without knockouts	68-74
<b>"Waterproof", for encapsulating</b>	75-85
<b>Approved for intrinsic fire resistance and insulation integrity</b>	86-102
For cable trunking and conduit installation	103 -106
Cable entry via elastic membranes in the box walls	107-112
Cable entry via elastic membranes in bottom and box walls	113-116
Accessories	117-126
Technical details cable junction boxes	127-141

Further technical information can be found on the Internet  
[www.hensel-electric.de](http://www.hensel-electric.de) -> Products

# Setting new standards. Every day.



[www.enycase.eu](http://www.enycase.eu)



## Various cable entry push-in and it's done



- cable entry via integrated elastic membranes in box walls for fast cable entry up to degree of protection IP 66



- alternatively, a cable gland can be set after removing the elastic membrane and extension ring



- cable entry through the bottom of the box via integrated elastic membrane

## Modern terminal technology innovative und flexibel



- different terminal positions and mounting options
- up to enclosure size 10 mm<sup>2</sup> two terminal bars can be mounted in one box, even different terminal sizes are possible



- High-positioned terminals offer more space for wiring - as well when connecting the maximum number of conductors
- protected against accidental loosening



- all terminals with two clamping units per pole
- all terminals with two clamping units per pole
- every pole allows the connection of various conductor cross sections and conductor types

## Lots of accessories perfectly included



- external brackets for fastening are always included



- retaining strap prevents the lid from falling or losing and makes daily installation work easier

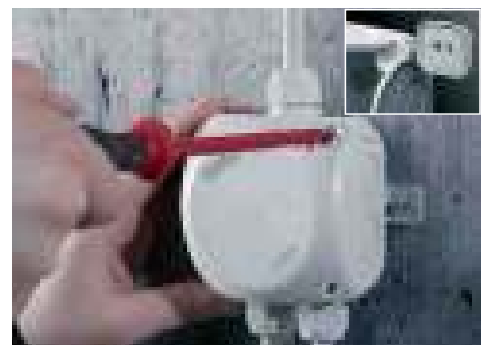

- closes quickly by a quarter turn, closed position is easily visible
- Easy identification using label as accessories



Model	Present types	New types
1.5-2.5 mm <sup>2</sup>	D 9025. D 9125	DK 0202 G
		DK 0402 G (larger enclosure)
1.5-4 mm <sup>2</sup>	D 9045	DK 0404 G
		DK 0604 G (larger enclosure)
2.5-6 mm <sup>2</sup>	K 9065	DK 0606 G
		DK 1006 G (larger enclosure)
4-10 mm <sup>2</sup>	K 9105	DK 1010 G
		DK 1610 G (larger enclosure)
10-16 mm <sup>2</sup>	---	DK 1616 G
10-25 mm <sup>2</sup>	K 9255	DK 2525 G
16-35 mm <sup>2</sup>	K 9355	DK 3535 G
16-50 mm <sup>2</sup>	K 9502	entfällt
	K 9504	DK 5054 G
	K 9505	DK 5055 G
without terminals	D 9020 D 9120	DK 0200 G
	D 9040	DK 0400 G
	K 9060	DK 0600 G
	K 9100	DK 1000 G
	---	DK 1600 G
	K 9250	DK 2500 G
	K 9350	DK 3500 G
	K 9500	DK 5000 G



for copper conductors



Model	Present types	New types
without terminals	D 9220	DK 0200 R
1.5-2.5 mm <sup>2</sup>	D 9225	DK 0202 R
		DK 0402 R (larger enclosure)
without terminals	D 9240	DK 0400 R
1.5-4 mm <sup>2</sup>	D 9245	DK 0404 R
		DK 0604 R (larger enclosure)

for safety  
lighting  
circuits



Model	Present types	New types
1.5-2.5 mm <sup>2</sup>	D 9041	DK 0402 A
1.5-4 mm <sup>2</sup>	K 9061	DK 0604 A
6-16 mm <sup>2</sup>	K 9351	DK 2516 A
1.5-50 mm <sup>2</sup>	KF 9251	KF 3550 A
1.5-50 mm <sup>2</sup>	KF 9501	KF 5050 A

for  
aluminum  
conductors

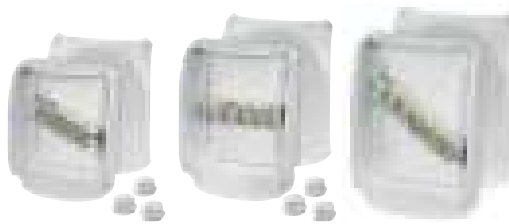

Model	Present types	New types
6-25 mm <sup>2</sup>	K 9259	DK 2524 S
6-25 mm <sup>2</sup>	K 9258	DK 3525 S
6-35 mm <sup>2</sup>	K 9509	DK 3534 S
6-35 mm <sup>2</sup>	K 9507	DK 5035 S
6-25 mm <sup>2</sup>	K 9508	omitted
6-25 mm <sup>2</sup>	K 9503	omitted

with main line  
branch  
terminals



Model	Present types	New types
1.5-2.5 mm <sup>2</sup>	RD 9123	RK 0203 T
	RD 9125	RK 0205 T
	RD 9127	RK 0207 T
1.5-4 mm <sup>2</sup>	RD 9045	RK 0405 T
	RD 9041	RK 0610 T
	RK 9062	RK 0612 T
	RK 9064	RK 0614 T
	RK 9109	RK 1019 T
	RK 9104	RK 1024 T

with  
terminal  
locks

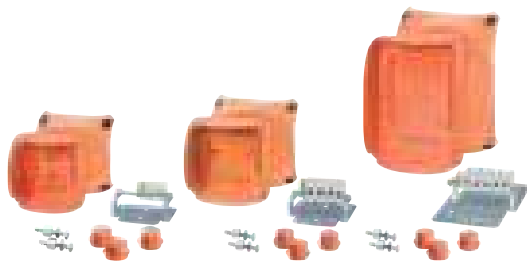

Model	Present types	New types
1.5-2.5 mm <sup>2</sup>	FK 7045	FK 0402
1.5-4 mm <sup>2</sup>		FK 0404
1.5-6 mm <sup>2</sup>	FK 7105	FK 0604
1.5-6 mm <sup>2</sup>		FK 0606
1.5-10 mm <sup>2</sup>		FK 1610
1.5-16 mm <sup>2</sup>	FK 7165	FK 1616
1.5-6 mm <sup>2</sup>	---	FK 1606
1.5-2.5 mm <sup>2</sup>	---	FK 1608

tested for insula-  
tion integrity  
and intrinsic fire  
resistance





Model	Present types	New types
1.5-2.5 mm <sup>2</sup>	KF 9025	KF 0202 G
		KF 0402 G (larger enclosure)
1.5-4 mm <sup>2</sup>	KF 9045	KF 0404 G
		KF 0604 G (larger enclosure)
2.5-6 mm <sup>2</sup>	KF 9065	KF 0606 G
		KF 1006 G (larger enclosure)
4-10 mm <sup>2</sup>	KF 9105	KF 1010 G
		KF 1610 G (larger enclosure)
6-16 mm <sup>2</sup>	---	KF 1616 G
10-25 mm <sup>2</sup>	KF 9255	KF 2525 G
16-35 mm <sup>2</sup>	KF 9355	KF 3535 G
16-50 mm <sup>2</sup>	KF 9505	KF 5050 G
without terminal	KF 9020	KF 0200 G
	KF 9040	KF 0400 G
	KF 9060	KF 0600 G
	KF 9100	KF 1000 G
	---	KF 1600 G
	KF 9250	KF 2500 G
	KF 9350	KF 3500 G
	KF 9500	KF 5000 G
1.5-2.5 mm <sup>2</sup>	KF 5025 KD 5025	KF 0202 B
		KF 0402 B (larger enclosure)
1.5-4 mm <sup>2</sup>	KF 5045 KD 5045	KF 0404 B
		KF 0604 B (larger enclosure)
2.5-6 mm <sup>2</sup>	KF 5065 KD 5065	KF 0606 B
		KF 1006 B (larger enclosure)
4-10 mm <sup>2</sup>	KF 5105 KD 5105	KF 1010 B
		KF 1610 B (larger enclosure)
6-16 mm <sup>2</sup>	---	KF 1616 B
10-25 mm <sup>2</sup>	KF 5255 KD 5255	KF 2525 B
16-35 mm <sup>2</sup>	KF 5355 KD 5355	KF 3535 B
16-50 mm <sup>2</sup>	KF 5505	KF 5050 B
without terminal	KF 5020 KD 5020	KF 0200 B
	KF 5040 KD 5040	KF 0400 B
	KF 5060 KD 5060	KF 0600 B
	KF 5100 KD 5100	KF 1000 B
	---	KF 1600 B
	KF 5250 KD 5250	KF 2500 B
	KF 5350 KD 5350	KF 3500 B
	KF 5500	KF 5000 B

**weatherproof,  
for outdoor installation**



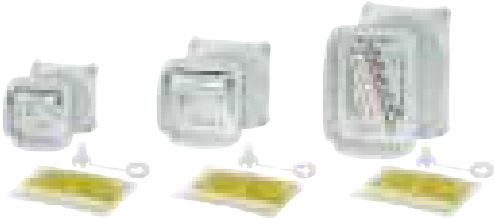



	Model	Present types	New types
	without knockouts	KF 8020	<b>KF 0200 H</b>
		KF 8040	<b>KF 0400 H</b>
		KF 8060	<b>KF 0600 H</b>
		KF 8100	<b>KF 1000 H</b>
		---	<b>KF 1600 H</b>
		KF 8250	<b>KF 2500 H</b>
		KF 8350	<b>KF 3500 H</b>
		KF 8500	<b>KF 5000 H</b>
	without knockouts	KF 4020	<b>KF 0200 C</b>
		KD 4020	
		KF 4040	<b>KF 0400 C</b>
		KD 4040	
		KF 4060	<b>KF 0600 C</b>
		KD 4060	
		KF 4100	<b>KF 1000 C</b>
		KD 4100	
		---	<b>KF 1600 C</b>
		KF 4250	<b>KF 2500 C</b>
		KD 4250	
		KF 4350	<b>KF 3500 C</b>
KD 4350			
KF 4500	<b>KF 5000 C</b>		

**weatherproof,  
for outdoor installation**

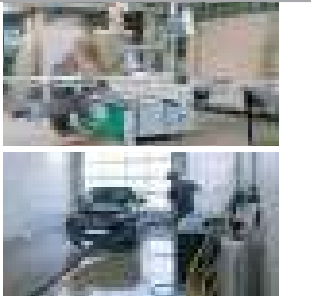
	Model	Present types	New types
	1.5-2.5 mm <sup>2</sup>	KF WP 3025	<b>WP 0202 G</b> <b>WP 0402 G</b> (larger enclosure)
	1.5-4 mm <sup>2</sup>	KF WP 3045	<b>WP 0404 G</b> <b>WP 0604 G</b> (larger enclosure)
	2.5-6 mm <sup>2</sup>	KF WP 3065	<b>WP 0606 G</b> <b>WP 1006 G</b> (larger enclosure)
	4-10 mm <sup>2</sup>	KF WP 3105	<b>WP 1010 G</b>
	1.5-2.5 mm <sup>2</sup>	KF WP 2025	<b>WP 0202 B</b> <b>WP 0402 B</b> (larger enclosure)
	1.5-4 mm <sup>2</sup>	KF WP 2045	<b>WP 0404 B</b> <b>WP 0604 B</b> (larger enclosure)
	2.5-6 mm <sup>2</sup>	KF WP 2065	<b>WP 0606 B</b> <b>WP 1006 B</b> (larger enclosure)
	4-10 mm <sup>2</sup>	KF WP 2105	<b>WP 1010 B</b>

**waterproof,  
for encapsulating**

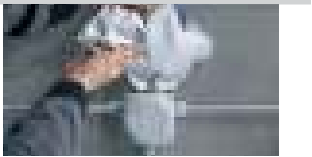
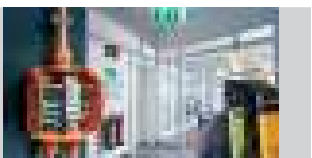
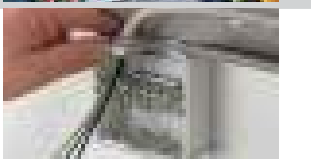
\*larger enclosure with more space for wiring

Applications	Electrical functions		
	Branching and connecting of copper conductors	Branching and connecting of aluminium and copper conductors	
<ul style="list-style-type: none"> <li>▪ In rooms with dry climate</li> <li>▪ In damp and wet environments</li> <li>▪ Protected outdoors (refer to technical details)</li> <li>▪ On flameable parts of buildings</li> <li>▪ In buildings with mainly inflammable materials</li> <li>▪ In areas with a high risk of fire</li> </ul>		<p>Pages 19-28 Pages 104-115</p>	<p>Pages 30-35</p>
<ul style="list-style-type: none"> <li>▪ <b>Safety lighting circuits</b> DIN VDE 0100 E DIN VDE 0108-100</li> </ul>		<p>Pages 37-39</p>	
<ul style="list-style-type: none"> <li>▪ <b>Equipotential bonding</b></li> </ul>		<p>Page 40</p>	
<ul style="list-style-type: none"> <li>▪ <b>Weatherproof, unprotected outdoors</b> (DIN VDE 0100 Part 737 German Standard)</li> <li>▪ <b>Improved behaviour in case of fire</b> "flame-resistant" and "halogenfree"</li> </ul>		<p>Pages 50-74</p>	
<ul style="list-style-type: none"> <li>▪ <b>Waterproof for encapsulation, unprotected outdoors</b></li> </ul>		<p>Pages 77-84</p>	
<ul style="list-style-type: none"> <li>▪ <b>Intrinsic fire resistance and insulation integrity</b> E30 / E60 / E 90 PH120</li> </ul>		<p>Pages 90-99</p>	
<ul style="list-style-type: none"> <li>▪ <b>Cable trunking installation</b></li> </ul>		<p>Pages 104-105</p>	
<ul style="list-style-type: none"> <li>▪ <b>Cable entry via elastic membranes</b> Three entries in one box wall Cable entry from the rear</li> </ul>		<p>Pages 108-111 Pages 114-115</p>	

Connecting of solid conductors and stranded conductors	Combining multiple control wires to one control cable	2 circuits in one cable junction box	Main line branch terminals	Without terminals	Box walls without knockouts
Pages 19-22 Page 30 Page 31 DK 2516 A Pages 37-38 Pages 45-48	Pages 45-48	Pages 104-105	Page 42-43	Pages 27-28 Page 39 Pages 56-58 Pages 65-67 Pages 69-74 Page 105 Page 109 Page 110 DE 9321, DE 9341, Page 111	Pages 69-74
Pages 37-39				Page 39	
Pages 50-53 Page 54 KF 2525 G Pages 59-62 Page 63 KF 2525 B  Pages 77-84				Pages 56-58 Pages 65-67 Pages 69-74	Pages 69-74
		Pages 103-104 DP 9220, DP 9221, DP 9222		Page 104	

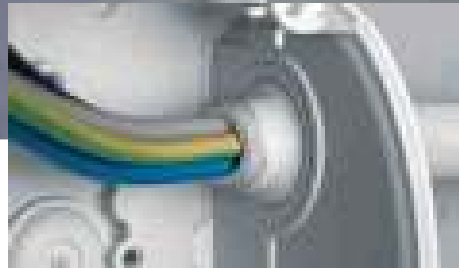

Reference table	
Present types	New types
D 9025	<b>DK 0202 G</b>
D 9125	<b>DK 0402 G</b>
D 9045	<b>DK 0404 G</b>
	<b>DK 0604 G</b>
K 9065	<b>DK 0606 G</b>
	<b>DK 1006 G</b>
K 9105	<b>DK 1010 G</b>
	<b>DK 1610 G</b>
---	<b>DK 1616 G</b>
K 9255	<b>DK 2525 G</b>
K 9355	<b>DK 3535 G</b>
K 9502	omitted
K 9504	<b>DK 5054 G</b>
K 9505	<b>DK 5055 G</b>
D 9020	<b>DK 0200 G</b>
D 9120	<b>DK 0400 G</b>
D 9040	<b>DK 0600 G</b>
K 9060	<b>DK 1000 G</b>
K 9100	<b>DK 1600 G</b>
---	<b>DK 1600 G</b>
K 9250	<b>DK 2500 G</b>
K 9350	<b>DK 3500 G</b>
K 9500	<b>DK 5000 G</b>

### DK Cable junction boxes

**For normal environment and protected outdoor**  
**Cable entry via integrated elastic membranes or**

- With elastic membrane, which can be removed for cable entry via cable glands
- Multi-level knockouts for cable glands in different sizes
- Cable entry through the bottom of the box via integrated elastic membrane
- Closes quickly by a quarter turn - locked position well visible (open - locked)
- Lid fasteners sealable without accessories
- External brackets for wall fixing included
- Retaining strap, details see product description
- Labelling system for circuit description
- High-position terminals with more space for wiring
- All terminals with two clamping units per pole
- Every pole allows the connection of various conductor cross sections and conductor types
- Terminals prevent damage of conductors, also with flexible conductors without ferrule
- Different terminal positions and fastening options
- Material: polypropylene or polycarbonate
- Burning behaviour: glow wire test in accordance with IEC 60695-2-11: 750 °C, flame-retardant, self-extinguishing
- Colour: grey, RAL 7035

**DK Cable junction boxes**  
**For normal environment and protected outdoor**  
**Cable entry via integrated elastic membranes or metric knockouts**



**DK 0202 G** NEW  
**1.5-2.5 mm<sup>2</sup>, Cu 3~**

- terminal with 2 clamping units per pole
- 5-pole per pole 8 x 0,75 mm<sup>2</sup> f, 6 x 1,5 mm<sup>2</sup> sol / f, 4 x 2,5 mm<sup>2</sup> sol / f, 2 x 4 mm<sup>2</sup> sol / f
- with integrated elastic membranes, which can be removed for cable entry via cable glands, sealing range 6.0-15.0 mm
- with one cable entry in the bottom, sealing range Ø 6.0-13.0 mm
- lid fasteners sealable without accessories
- retaining strap and external brackets for wall fixing included

rated insulation voltage	U <sub>i</sub> = 690 V a.c./d.c.
current carrying capacity	20 A
tightening torque for terminal	0.5 Nm
material	PP (polypropylene)

IP  
66

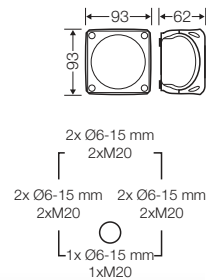

**DK 0402 G** NEW  
**1.5-2.5 mm<sup>2</sup>, Cu 3~**

- terminal with 2 clamping units per pole
- 5-pole per pole 8 x 0,75 mm<sup>2</sup> f, 6 x 1,5 mm<sup>2</sup> sol / f, 4 x 2,5 mm<sup>2</sup> sol / f, 2 x 4 mm<sup>2</sup> sol / f
- with elastic membranes, which can be removed for cable entry via cable glands, sealing range 9.0-17.0 mm
- with one cable entry in the bottom, sealing range Ø 6.0-15.0 mm
- lid fasteners sealable without accessories
- retaining strap and external brackets for wall fixing included

rated insulation voltage	U <sub>i</sub> = 690 V a.c./d.c.
current carrying capacity	20 A
tightening torque for terminal	0.5 Nm
material	PP (polypropylene)

IP  
66

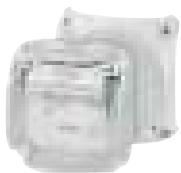
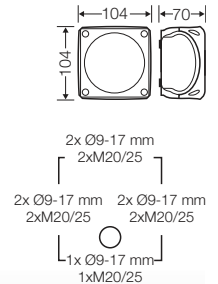

**DK 0404 G** NEW  
**1.5-4 mm<sup>2</sup>, Cu 3~**

- terminal with 2 clamping units per pole
- 5-pole per pole 8 x 1,5 mm<sup>2</sup> sol / f, 6 x 2,5 mm<sup>2</sup> sol / f, 4 x 4 mm<sup>2</sup> sol / f, 2 x 6 mm<sup>2</sup> sol / f
- with elastic membranes, which can be removed for cable entry via cable glands, sealing range 9.0-17.0 mm
- with one cable entry in the bottom, sealing range Ø 6.0-15.0 mm
- lid fasteners sealable without accessories
- retaining strap and external brackets for wall fixing included

rated insulation voltage	U <sub>i</sub> = 690 V a.c./d.c.
current carrying capacity	32 A
tightening torque for terminal	0.7 Nm
material	PP (polypropylene)

IP  
66

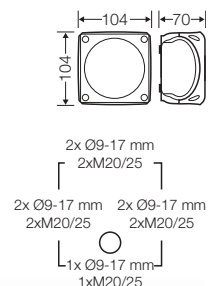

**DK Cable junction boxes**  
**For normal environment and protected outdoor**  
**Cable entry via integrated elastic membranes or metric knockouts**



**DK 0604 G** NEW

**1.5-4 mm<sup>2</sup>, Cu 3~**

- terminal with 2 clamping units per pole
- 5-pole per pole 8 x 1,5 mm<sup>2</sup> sol / f, 6 x 2,5 mm<sup>2</sup> sol / f, 4 x 4 mm<sup>2</sup> sol / f, 2 x 6 mm<sup>2</sup> sol / f
- with elastic membranes, which can be removed for cable entry via cable glands, sealing range 9.0-21.0 mm
- with one cable entry in the bottom, sealing range Ø 9.0-20.0 mm
- lid fasteners sealable without accessories
- retaining strap and external brackets for wall fixing included

rated insulation voltage	U <sub>i</sub> = 690 V a.c./d.c.
current carrying capacity	32 A
tightening torque for terminal	0.7 Nm
material	PP (polypropylene)

IP  
66

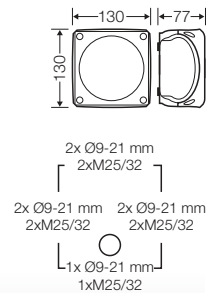

**DK 0606 G** NEW

**2.5-6 mm<sup>2</sup>, Cu 3~**

- terminal with 2 clamping units per pole
- 5-pole per pole 6 x 1,5 mm<sup>2</sup> sol / f, 4 x 2,5 mm<sup>2</sup> sol / f, 4 x 4 mm<sup>2</sup> sol / f, 4 x 6 mm<sup>2</sup> sol / f, 2 x 10 mm<sup>2</sup> sol / f
- with elastic membranes, which can be removed for cable entry via cable glands, sealing range 9.0-21.0 mm
- with one cable entry in the bottom, sealing range Ø 9.0-20.0 mm
- lid fasteners sealable without accessories
- retaining strap and external brackets for wall fixing included

rated insulation voltage	U <sub>i</sub> = 690 V a.c./d.c.
current carrying capacity	40 A
tightening torque for terminal	1.5 Nm
material	PP (polypropylene)

IP  
66

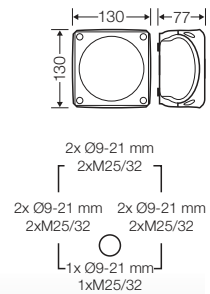

**DK 1006 G** NEW

**2.5-6 mm<sup>2</sup>, Cu 3~**

- terminal with 2 clamping units per pole
- 5-pole per pole 6 x 1,5 mm<sup>2</sup> sol / f, 4 x 2,5 mm<sup>2</sup> sol / f, 4 x 4 mm<sup>2</sup> sol / f, 4 x 6 mm<sup>2</sup> sol / f, 2 x 10 mm<sup>2</sup> sol / f
- with elastic membranes, which can be removed for cable entry via cable glands, sealing range 9.0-21.0 mm
- with two cable entries in the bottom, sealing range Ø 9.0-20.0 mm
- lid fasteners sealable without accessories
- retaining strap and external brackets for wall fixing included

rated insulation voltage	U <sub>i</sub> = 690 V a.c./d.c.
current carrying capacity	40 A
tightening torque for terminal	1.5 Nm
material	PP (polypropylene)

IP  
66

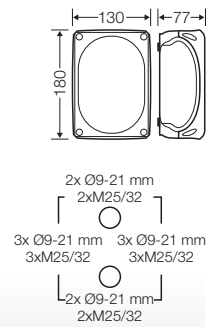

**DK Cable junction boxes**

For normal environment and protected outdoor

Cable entry via integrated elastic membranes or metric knockouts



**DK 1010 G** NEW

**4-10 mm<sup>2</sup>, Cu 3~**

- terminal with 2 clamping units per pole
- 5-pole per pole 6 x 2.5 mm<sup>2</sup> sol, 4 x 4 mm<sup>2</sup> sol, 4 x 6 mm<sup>2</sup> sol, 4 x 10 mm<sup>2</sup> sol, 2 x 16 mm<sup>2</sup> s
- with elastic membranes, which can be removed for cable entry via cable glands, sealing range 9.0-21.0 mm
- with two cable entries in the bottom, sealing range Ø 9.0-20.0 mm
- lid fasteners sealable without accessories
- retaining strap and external brackets for wall fixing included

rated insulation voltage	U <sub>i</sub> = 690 V a.c./d.c.
current carrying capacity	63 A
tightening torque for terminal	2.0 Nm
material	PP (polypropylene)

IP  
66

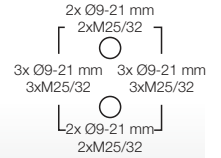
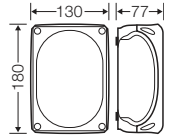

**DK Cable junction boxes**

For normal environment and protected outdoor installation  
Cable entry via metric knockouts



**DK 1610 G** NEW

**4-10 mm<sup>2</sup>, Cu 3~**

- terminal with 2 clamping units per pole
- 5-pole per pole 6 x 2.5 mm<sup>2</sup> sol, 4 x 4 mm<sup>2</sup> sol, 4 x 6 mm<sup>2</sup> sol, 4 x 10 mm<sup>2</sup> sol, 2 x 16 mm<sup>2</sup> s
- included cable entry: 3 ESM 40, sealing range Ø 17-30 mm
- with two cable entries M 32 from the rear side
- lid fasteners sealable without accessories
- external brackets for wall fixing included

rated insulation voltage	U <sub>i</sub> = 690 V a.c./d.c.
current carrying capacity	63 A
tightening torque for terminal	2.0 Nm
material	PC (polycarbonate)

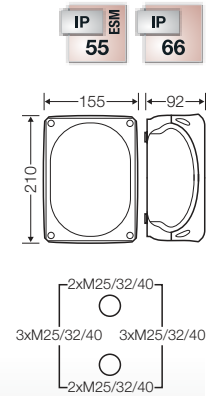

**DK 1616 G** NEW

**10-16 mm<sup>2</sup>, Cu 3~**

- terminal with 2 clamping units per pole
- 5-pole per pole 6 x 6 mm<sup>2</sup> sol, 6 x 10 mm<sup>2</sup> sol/ f\*, 4 x 16 mm<sup>2</sup> s/ f\*, 4 x 25 mm<sup>2</sup> s/ f\*, 2 x 35 mm<sup>2</sup> s/ f\*  
f\* = with gas-tight end ferrule
- included cable entry: 3 ESM 40, sealing range Ø 17-30 mm
- with two cable entries M 32 from the rear side
- lid fasteners sealable without accessories
- external brackets for wall fixing included

rated insulation voltage	U <sub>i</sub> = 690 V a.c./d.c.
current carrying capacity	102 A
tightening torque for terminal	3.0 Nm
material	PC (polycarbonate)

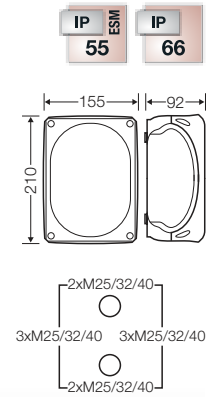

**DK 2525 G** NEW

**10-25 mm<sup>2</sup>, Cu 3~**

- terminal with 2 clamping units per pole
- 5-pole per pole 6 x 6 mm<sup>2</sup> sol, 6 x 10 mm<sup>2</sup> sol/ f\*, 4 x 16 mm<sup>2</sup> s/ f\*, 4 x 25 mm<sup>2</sup> s/ f\*, 2 x 35 mm<sup>2</sup> s/ f\*  
f\* = with gas-tight end ferrule
- included cable entry: 3 ESM 40, sealing range Ø 17-30 mm
- with two cable entries M 32 from the rear side
- lid fasteners sealable without accessories
- external brackets for wall fixing included

rated insulation voltage	U <sub>i</sub> = 690 V a.c./d.c.
current carrying capacity	102 A
tightening torque for terminal	3.0 Nm
material	PC (polycarbonate)

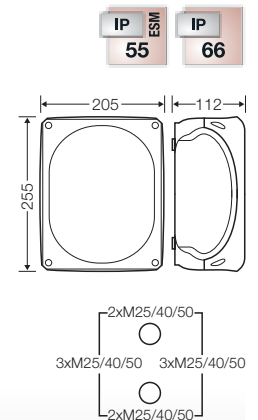

**DK Cable junction boxes**  
**For normal environment and protected outdoor installation**  
**Cable entry via metric knockouts**



**DK 3535 G** NEW  
**16-35 mm<sup>2</sup>, Cu 3~**

- terminal with 2 clamping units per pole
- 5-pole per pole 6 x 16 mm<sup>2</sup> s, 4 x 25 mm<sup>2</sup> s, 4 x 35 mm<sup>2</sup> s, 2 x 50 mm<sup>2</sup> s
- included cable entry: 3 ESM 40, sealing range Ø 17-30 mm
- with two cable entries M 32 from the rear side
- lid fasteners sealable without accessories
- external brackets for wall fixing included

rated insulation voltage	U <sub>i</sub> = 690 V a.c./d.c.
current carrying capacity	125 A
tightening torque for terminal material	12.0 Nm PC (polycarbonate)

IP ESM  
55 66

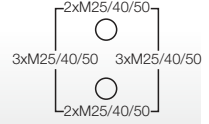
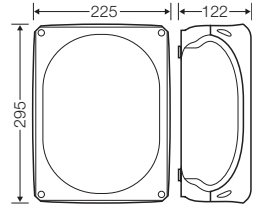

**DK 5054 G** NEW  
**16-50 mm<sup>2</sup>, Cu 3~**

- terminal with 2 clamping units per pole
- 4-pole per pole 6 x 16 mm<sup>2</sup> s, 4 x 25 mm<sup>2</sup> s, 4 x 35 mm<sup>2</sup> s, 4 x 50 mm<sup>2</sup> s
- with two cable entries M 32 from the rear side
- cable entries via knockouts, order AKM separately (see cable entry systems LES)
- lid fasteners sealable without accessories
- external brackets for wall fixing included

rated insulation voltage	U <sub>i</sub> = 690 V a.c./d.c.
current carrying capacity	150 A
tightening torque for terminal material	12.0 Nm PC (polycarbonate)

IP  
66

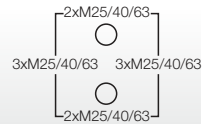
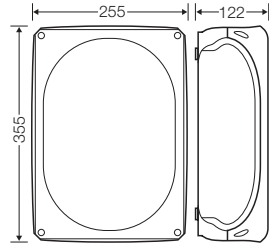

**DK 5055 G** NEW  
**16-50 mm<sup>2</sup>, Cu 3~**

- terminal with 2 clamping units per pole
- 5-pole per pole 6 x 16 mm<sup>2</sup> s, 4 x 25 mm<sup>2</sup> s, 4 x 35 mm<sup>2</sup> s, 4 x 50 mm<sup>2</sup> s
- with two cable entries M 32 from the rear side
- cable entries via knockouts, order AKM separately (see cable entry systems LES)
- lid fasteners sealable without accessories
- external brackets for wall fixing included

rated insulation voltage	U <sub>i</sub> = 690 V a.c./d.c.
current carrying capacity	150 A
tightening torque for terminal material	12.0 Nm PC (polycarbonate)

IP  
66

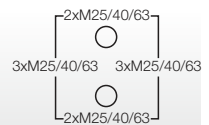
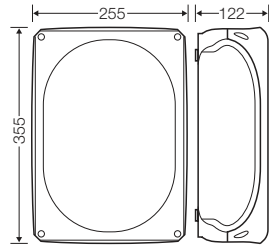

**DK Cable junction boxes**

For normal environment and protected outdoor installation  
Cable entry via metric knockouts



**K 7055**

**16-50 mm<sup>2</sup>, Cu 3~**

- with terminals
- 5-pole per pole 6 x 16 mm<sup>2</sup> s, 4 x 25 mm<sup>2</sup> s, 4 x 35 mm<sup>2</sup> s, 4 x 50 mm<sup>2</sup> s
- sealable
- order cable glands, flanges and other accessories separately as required
- for normal environment and protected outdoor

rated insulation voltage	$U_i = 690 \text{ V a.c./d.c.}$
current carrying capacity	150 A
tightening torque for terminal	12.0 Nm
material	PC (polycarbonate)

IP  
65

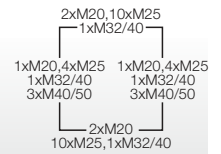
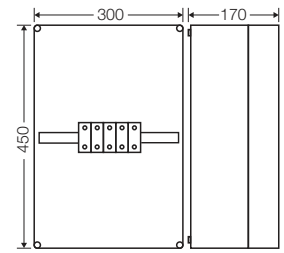

**K 7004**

**16-70 mm<sup>2</sup>, Cu 3~**

- with terminals
- 4-pole per pole 4 x 16-70 mm<sup>2</sup> s
- sealable
- order cable glands, flanges and other accessories separately as required
- for normal environment and protected outdoor

rated insulation voltage	$U_i = 690 \text{ V a.c./d.c.}$
current carrying capacity	216 A
tightening torque for terminal	10.0 Nm
material	PC (polycarbonate)

IP  
65

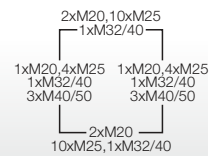
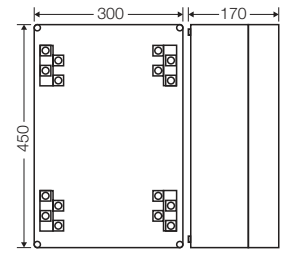

**K 7005**

**16-70 mm<sup>2</sup>, Cu 3~**

- with terminals
- 5-pole per pole 4 x 16-70 mm<sup>2</sup> s
- sealable
- order cable glands, flanges and other accessories separately as required
- for normal environment and protected outdoor

rated insulation voltage	$U_i = 690 \text{ V a.c./d.c.}$
current carrying capacity	216 A
tightening torque for terminal	10.0 Nm
material	PC (polycarbonate)

IP  
65

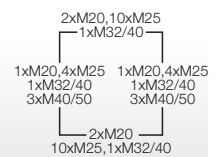
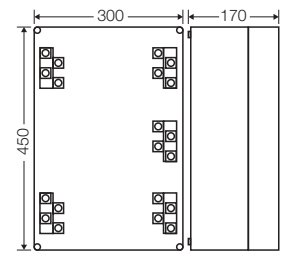



**K 1204**

**16-150 mm<sup>2</sup>, Cu/Alu 3~**

- with terminals
- 4-pole per pole 2 x 16-150 mm<sup>2</sup>, 4 x 16-70 mm<sup>2</sup>, conductors can be inserted from the front into the clamping unit, terminal technology, see annex DK Cable junction boxes
- sealable
- order cable glands, flanges and other accessories separately as required
- before connecting, aluminum conductors must be pre-treated according to the appropriate technical recommendations, see technical information aluminum conductors
- for normal environment and protected outdoor

rated insulation voltage	$U_i = 690 \text{ V a.c./d.c.}$
current carrying capacity	250 A
tightening torque for terminal material	20.0 Nm PC (polycarbonate)

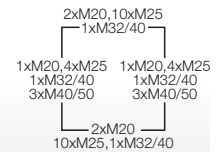
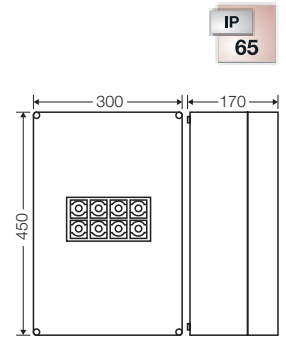

**K 1205**

**16-150 mm<sup>2</sup>, Cu/Alu 3~**

- with terminals
- 5-pole per pole 2 x 16-150 mm<sup>2</sup>, 4 x 16-70 mm<sup>2</sup>, conductors can be inserted from the front into the clamping unit, terminal technology, see annex DK Cable junction boxes
- sealable
- order cable glands, flanges and other accessories separately as required
- before connecting, aluminum conductors must be pre-treated according to the appropriate technical recommendations, see technical information aluminum conductors
- for normal environment and protected outdoor

rated insulation voltage	$U_i = 690 \text{ V a.c./d.c.}$
current carrying capacity	250 A
tightening torque for terminal material	20.0 Nm PC (polycarbonate)

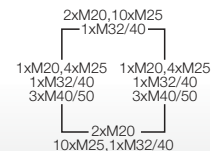
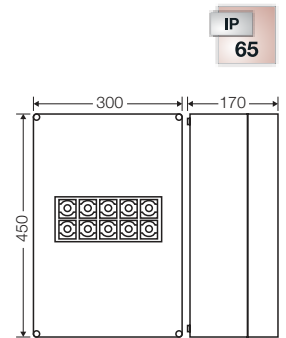

**K 2404**

**25-240 mm<sup>2</sup>, Cu/Alu 3~**

- with terminals
- 4-pole per pole 2 x 25-185/240 mm<sup>2</sup>, 4 x 25-120 mm<sup>2</sup>, conductors can be inserted from the front into the clamping unit, terminal technology, see annex DK Cable junction boxes
- sealable
- order cable glands, flanges and other accessories separately as required
- before connecting, aluminum conductors must be pre-treated according to the appropriate technical recommendations, see technical information aluminum conductors
- for normal environment and protected outdoor

rated insulation voltage	$U_i = 690 \text{ V a.c./d.c.}$
current carrying capacity	400 A
tightening torque for terminal material	40.0 Nm PC (polycarbonate)

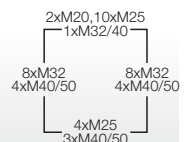
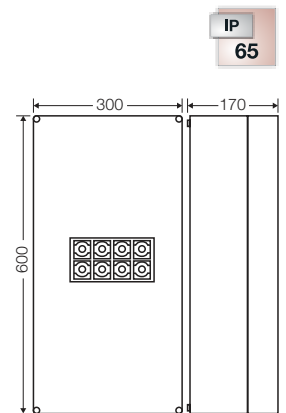

**DK Cable junction boxes**

For normal environment and protected outdoor installation  
Cable entry via metric knockouts



**K 2405**

**25-240 mm<sup>2</sup>, Cu/Alu 3~**

- with terminals
- 5-pole per pole 2 x 25-185/240 mm<sup>2</sup>, 4 x 25-120 mm<sup>2</sup>, conductors can be inserted from the front into the clamping unit, terminal technology, see annex DK Cable junction boxes
- sealable
- order cable glands, flanges and other accessories separately as required
- before connecting, aluminum conductors must be pre-treated according to the appropriate technical recommendations, see technical information aluminum conductors
- for normal environment and protected outdoor

IP  
65

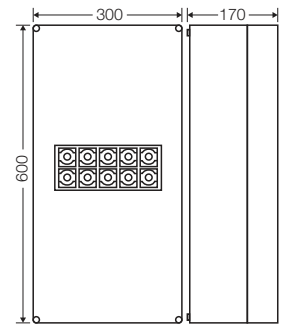

rated insulation voltage	$U_i = 690 \text{ V a.c./d.c.}$
current carrying capacity	400 A
tightening torque for terminal	40.0 Nm
material	PC (polycarbonate)

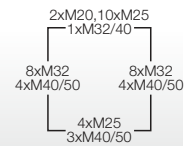

**DK Cable junction boxes**  
**For normal environment and protected outdoor**  
**Cable entry via integrated elastic membranes or metric knockouts**



**DK 0200 G** **NEW**

- without terminals
- with integrated elastic membranes, which can be removed for cable entry via cable glands, sealing range 6.0-15.0 mm
- with one cable entry in the bottom, sealing range Ø 6.0-13.0 mm
- lid fasteners sealable without accessories
- retaining strap and external brackets for wall fixing included

material	PP (polypropylene)
----------	--------------------

IP  
66

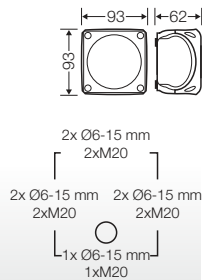

**DK 0400 G** **NEW**

- without terminals
- with elastic membranes, which can be removed for cable entry via cable glands, sealing range 9.0-17.0 mm
- with one cable entry in the bottom, sealing range Ø 6.0-15.0 mm
- lid fasteners sealable without accessories
- retaining strap and external brackets for wall fixing included

material	PP (polypropylene)
----------	--------------------

IP  
66

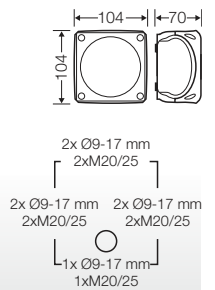

**DK 0600 G** **NEW**

- without terminals
- with elastic membranes, which can be removed for cable entry via cable glands, sealing range 9.0-21.0 mm
- with one cable entry in the bottom, sealing range Ø 9.0-20.0 mm
- lid fasteners sealable without accessories
- retaining strap and external brackets for wall fixing included

material	PP (polypropylene)
----------	--------------------

IP  
66

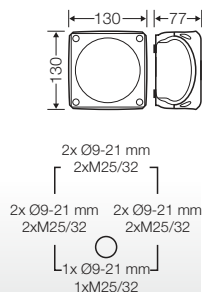

**DK 1000 G** **NEW**

- without terminals
- with elastic membranes, which can be removed for cable entry via cable glands, sealing range 9.0-21.0 mm
- with two cable entries in the bottom, sealing range Ø 9.0-20.0 mm
- lid fasteners sealable without accessories
- retaining strap and external brackets for wall fixing included

material	PP (polypropylene)
----------	--------------------

IP  
66

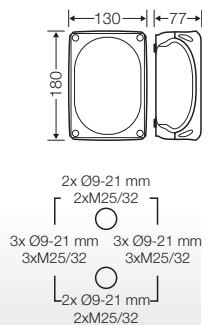

**DK Cable junction boxes**

For normal environment and protected outdoor installation  
Cable entry via metric knockouts



**DK 1600 G** NEW

- without terminals
- included cable entry: 3 ESM 40, sealing range Ø 17-30 mm
- with two cable entries M 32 from the rear side
- lid fasteners sealable without accessories
- external brackets for wall fixing included

material	PC (polycarbonate)
----------	--------------------

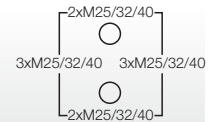
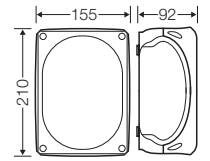

**DK 2500 G** NEW

- without terminals
- included cable entry: 3 ESM 40, sealing range Ø 17-30 mm
- with two cable entries M 32 from the rear side
- lid fasteners sealable without accessories
- external brackets for wall fixing included

material	PC (polycarbonate)
----------	--------------------

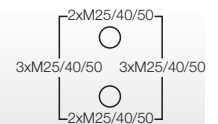
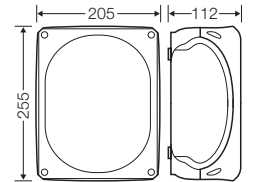

**DK 3500 G** NEW

- without terminals
- included cable entry: 3 ESM 40, sealing range Ø 17-30 mm
- with two cable entries M 32 from the rear side
- lid fasteners sealable without accessories
- external brackets for wall fixing included

material	PC (polycarbonate)
----------	--------------------

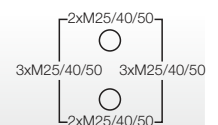
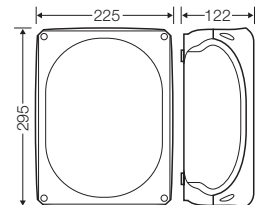

**DK 5000 G** NEW

- without terminals
- with two cable entries M 32 from the rear side
- cable entries via knockouts, order AKM separately (see cable entry systems LES)
- lid fasteners sealable without accessories
- external brackets for wall fixing included

material	PC (polycarbonate)
----------	--------------------

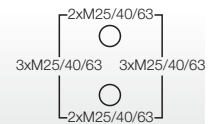
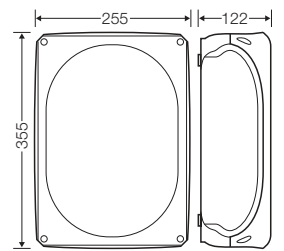



Reference table	
Present types	New types
D 9041	<b>DK 0402 A</b>
K 9061	<b>DK 0604 A</b>
K 9351	<b>DK 2516 A</b>
KF 9251	<b>KF 3550 A</b>
KF 9501	<b>KF 5050 A</b>



### DK Cable junction boxes

**For normal environment and protected outdoor  
With terminals for aluminum and copper conductors**

- Separate clamping units for aluminum and copper conductors
- Degree of protection IP 66, In the case of twisted cables IP 54 using cable glands
- Labelling system: label template in the Internet at [www.hensel-electric.de](http://www.hensel-electric.de) - downloads
- Material: polypropylene or polycarbonate
- Burning behaviour:  
Glow wire test in accordance with IEC 60695-2-11: 750 °C / 960 °C, flame-retardant, self-extinguishing
- Colour: grey, RAL 7035
- Before connecting, aluminum conductors must be pre-treated according to the appropriate technical recommendations, see technical information aluminum conductors

**DK Cable junction boxes**

With terminal blocks for aluminum and copper conductors

Cable entry via integrated elastic membranes or metric knockouts



**DK 0402 A** NEW

**1.5-2.5 mm<sup>2</sup>, Cu/Alu 3~**

- with terminals
- 5-pole per pole 4 x 1.5 mm<sup>2</sup> sol/f, 4 x 2.5 mm<sup>2</sup> sol/f, conductors are inserted into the screw-type terminal, terminal technology, see annex DK Cable junction boxes
- with elastic membranes, which can be removed for cable entry via cable glands, sealing range 9.0-17.0 mm
- to achieve the degree IP 54 with twisted cables, it is absolutely necessary to use cable glands
- with one cable entry in the bottom, sealing range Ø 6.0-15.0 mm
- lid fasteners sealable without accessories
- before connecting, aluminum conductors must be pre-treated according to the appropriate technical recommendations, see technical information aluminum conductors
- retaining strap and external brackets for wall fixing included

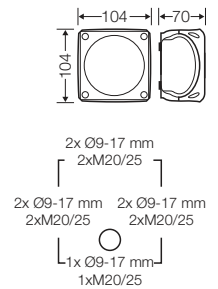

rated insulation voltage	$U_i = 250 \text{ V a.c./d.c.}$
current carrying capacity	20 A
tightening torque for terminal	0.5 Nm
material	PP (polypropylene)



**DK 0604 A** NEW

**1.5-4 mm<sup>2</sup>, Cu/Alu 3~**

- with terminals
- 5-pole per pole 4 x 1.5 mm<sup>2</sup> sol/f, 4 x 2.5 mm<sup>2</sup> sol/f, 4 x 4 mm<sup>2</sup> sol/f, conductors are inserted into the screw-type terminal, terminal technology, see annex DK Cable junction boxes
- with elastic membranes, which can be removed for cable entry via cable glands, sealing range 9.0-21.0 mm
- to achieve the degree IP 54 with twisted cables, it is absolutely necessary to use cable glands
- with one cable entry in the bottom, sealing range Ø 9.0-20.0 mm
- lid fasteners sealable without accessories
- before connecting, aluminum conductors must be pre-treated according to the appropriate technical recommendations, see technical information aluminum conductors
- retaining strap and external brackets for wall fixing included

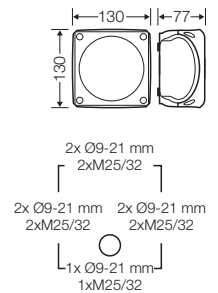

rated insulation voltage	$U_i = 400 \text{ V a.c./d.c.}$
current carrying capacity	20 A
tightening torque for terminal	0.7 Nm
material	PP (polypropylene)

**DK Cable junction boxes**  
**With terminals for aluminum and copper conductors**  
**Cable entry via metric knockouts**



**DK 2516 A** NEW  
**6-16 mm<sup>2</sup>, Cu/Alu 3~**

- with terminals
- 5-pole per pole 4 x 6 mm<sup>2</sup> sol/f, 4 x 10 mm<sup>2</sup> sol/f, 4 x 16 mm<sup>2</sup> sol/s/f, conductors are inserted into the screw-type terminal, terminal technology, see annex DK Cable junction boxes
- included cable entry: 3 ESM 40, sealing range Ø 17-30 mm
- with two cable entries M 32 from the rear side
- lid fasteners sealable without accessories
- before connecting, aluminum conductors must be pre-treated according to the appropriate technical recommendations, see technical information aluminum conductors
- external brackets for wall fixing included

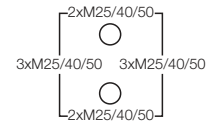
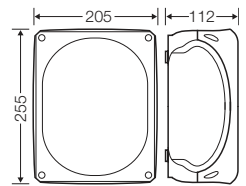

rated insulation voltage	$U_i = 690 \text{ V a.c./d.c.}$
current carrying capacity	76 A
tightening torque for terminal material	3.0 Nm
	PC (polycarbonate)



**KF 3550 A** NEW  
**1.5-50 mm<sup>2</sup>, Cu/Alu 3~**

- with connecting terminal
- 5-pole per pole 2 x 1 x 1.5-50 mm<sup>2</sup>, conductors are inserted into the screw-type terminal, terminal technology, see annex DK Cable junction boxes
- included cable entry: 2 EDK 40, sealing range Ø 11-30 mm, IP 65
- degree of protection IP 66 / IP 67 / IP 69, order cable glands AKM separately (see cable entry systems LES)
- with two cable entries M 32 from the rear side
- before connecting, aluminum conductors must be pre-treated according to the appropriate technical recommendations, see technical information aluminum conductors
- lid fasteners sealable without accessories
- external brackets for wall fixing included

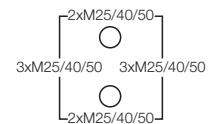
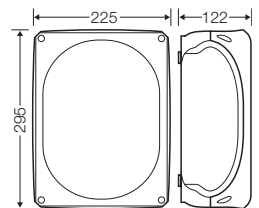

rated insulation voltage	$U_i = 690 \text{ V a.c./d.c.}$
current carrying capacity	
tightening torque for terminal	1.5 Nm 1.5-2.5 mm <sup>2</sup> 5.0 Nm 4-10 mm <sup>2</sup>
material	PC-GFS (polycarbonate)

Before connecting, aluminum conductors must be pre-treated according to the appropriate technical recommendations

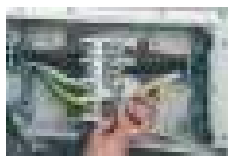

Conductor ends need to have the oxide layer carefully scraped clean.

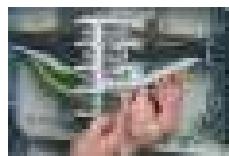

Conductor ends need to be rubbed with an acid and alkali free grease and immediately connected



The terminals need to be tightened with the appropriate torque

**DK Cable junction boxes**

With terminals for aluminum and copper conductors  
Cable entry via metric knockouts



**KF 5050 A** NEW

**1.5-50 mm<sup>2</sup>, Cu/Alu 3~**

- with connecting terminal
- 5-pole per pole 2 x 1 x 1.5-50 mm<sup>2</sup>, conductors are inserted into the screw-type terminal, terminal technology, see annex DK Cable junction boxes
- included cable entry: 2 EDK 40, sealing range Ø 11-30 mm, IP 65
- degree of protection IP 66 / IP 67 / IP 69, order cable glands AKM separately (see cable entry systems LES)
- with two cable entries M 32 from the rear side
- before connecting, aluminum conductors must be pre-treated according to the appropriate technical recommendations, see technical information aluminum conductors
- lid fasteners sealable without accessories
- external brackets for wall fixing included

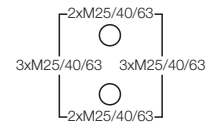
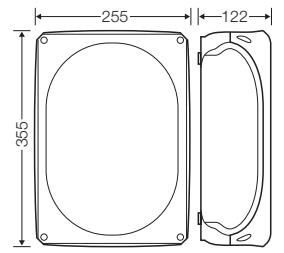

rated insulation voltage	$U_i = 690 \text{ V a.c./d.c.}$
current carrying capacity	
tightening torque for terminal	1.5 Nm 1.5-2.5 mm <sup>2</sup> 5.0 Nm 4-10 mm <sup>2</sup>
material	PC-GFS (polycarbonate)



**K 7051** NEW

**2.5-50 mm<sup>2</sup>, Cu/Alu 3~**

- with terminals
- 5-pole per pole 4 x 2.5-50 mm<sup>2</sup>, conductors are inserted into the screw-type terminal, terminal technology, see annex DK Cable junction boxes
- sealable
- order cable glands, flanges and other accessories separately as required
- before connecting, aluminum conductors must be pre-treated according to the appropriate technical recommendations, see technical information aluminum conductors
- for normal environment and protected outdoor

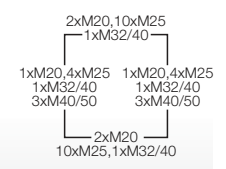
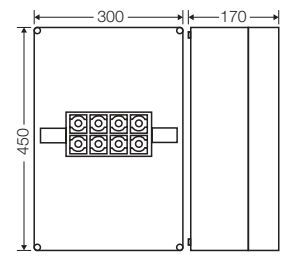

rated insulation voltage	$U_i = 750 \text{ V a.c./d.c.}$
current carrying capacity	copper, 150 A Al, 120 A
tightening torque for terminal	10.0 Nm
material	PC (polycarbonate)



**K 7042**

**10-95 mm<sup>2</sup> Cu/Alu 3~**

- with terminals
- 4-pole per pole 2 x 10-95 mm<sup>2</sup>, conductors can be inserted from the front into the clamping unit, terminal technology, see annex DK Cable junction boxes
- sealable
- order cable glands, flanges and other accessories separately as required
- before connecting, aluminum conductors must be pre-treated according to the appropriate technical recommendations, see technical information aluminum conductors
- for normal environment and protected outdoor

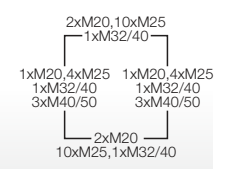
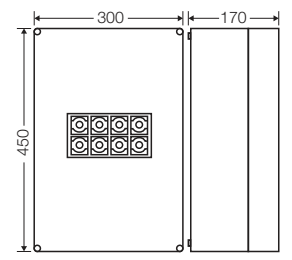

rated insulation voltage	$U_i = 690 \text{ V a.c./d.c.}$
current carrying capacity	160 A
tightening torque for terminal	20.0 Nm
material	PC (polycarbonate)

**DK Cable junction boxes**  
**With terminals for aluminum and copper conductors**  
**Cable entry via metric knockouts**



**K 7052**  
**10-95 mm<sup>2</sup> Cu/Alu 3~**

- with terminals
- 5-pole per pole 2 x 10-95 mm<sup>2</sup>, conductors can be inserted from the front into the clamping unit, terminal technology, see annex DK Cable junction boxes
- sealable
- order cable glands, flanges and other accessories separately as required
- before connecting, aluminum conductors must be pre-treated according to the appropriate technical recommendations, see technical information aluminum conductors
- for normal environment and protected outdoor

rated insulation voltage	$U_i = 690 \text{ V a.c./d.c.}$
current carrying capacity	160 A
tightening torque for terminal material	20.0 Nm PC (polycarbonate)

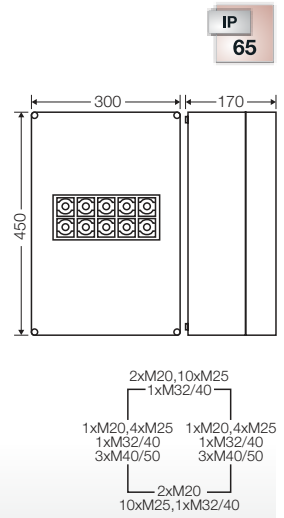

IP 65



**K 1204**  
**16-150 mm<sup>2</sup>, Cu/Alu 3~**

- with terminals
- 4-pole per pole 2 x 16-150 mm<sup>2</sup>, 4 x 16-70 mm<sup>2</sup>, conductors can be inserted from the front into the clamping unit, terminal technology, see annex DK Cable junction boxes
- sealable
- order cable glands, flanges and other accessories separately as required
- before connecting, aluminum conductors must be pre-treated according to the appropriate technical recommendations, see technical information aluminum conductors
- for normal environment and protected outdoor

rated insulation voltage	$U_i = 690 \text{ V a.c./d.c.}$
current carrying capacity	250 A
tightening torque for terminal material	20.0 Nm PC (polycarbonate)

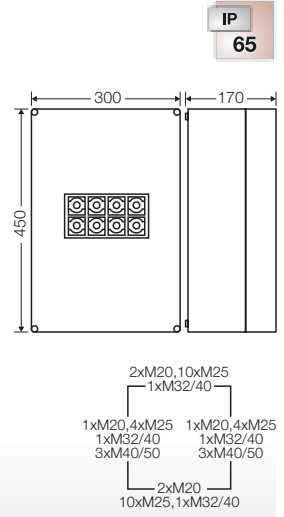

IP 65

Before connecting, aluminum conductors must be pre-treated according to the appropriate technical recommendations

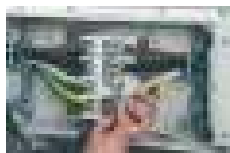

Conductor ends need to have the oxide layer carefully scraped clean.

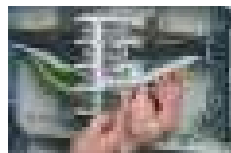

Conductor ends need to be rubbed with an acid and alkali free grease and immediately connected

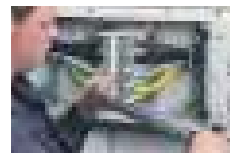

The terminals need to be tightened with the appropriate torque

**DK Cable junction boxes**

With terminals for aluminum and copper conductors  
Cable entry via metric knockouts



**K 1205**

**16-150 mm<sup>2</sup>, Cu/Alu 3~**

- with terminals
- 5-pole per pole 2 x 16-150 mm<sup>2</sup>, 4 x 16-70 mm<sup>2</sup>, conductors can be inserted from the front into the clamping unit, terminal technology, see annex DK Cable junction boxes
- sealable
- order cable glands, flanges and other accessories separately as required
- before connecting, aluminum conductors must be pre-treated according to the appropriate technical recommendations, see technical information aluminum conductors
- for normal environment and protected outdoor

rated insulation voltage	$U_i = 690 \text{ V a.c./d.c.}$
current carrying capacity	250 A
tightening torque for terminal	20.0 Nm
material	PC (polycarbonate)

IP  
65

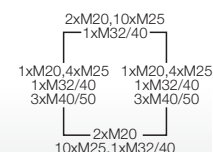
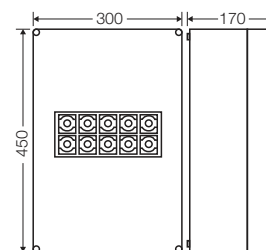

**K 2404**

**25-240 mm<sup>2</sup>, Cu/Alu 3~**

- with terminals
- 4-pole per pole 2 x 25-185/240 mm<sup>2</sup>, 4 x 25-120 mm<sup>2</sup>, conductors can be inserted from the front into the clamping unit, terminal technology, see annex DK Cable junction boxes
- sealable
- order cable glands, flanges and other accessories separately as required
- before connecting, aluminum conductors must be pre-treated according to the appropriate technical recommendations, see technical information aluminum conductors
- for normal environment and protected outdoor

rated insulation voltage	$U_i = 690 \text{ V a.c./d.c.}$
current carrying capacity	400 A
tightening torque for terminal	40.0 Nm
material	PC (polycarbonate)

IP  
65

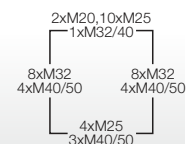
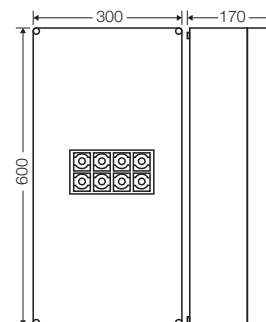

**K 2405**

**25-240 mm<sup>2</sup>, Cu/Alu 3~**

- with terminals
- 5-pole per pole 2 x 25-185/240 mm<sup>2</sup>, 4 x 25-120 mm<sup>2</sup>, conductors can be inserted from the front into the clamping unit, terminal technology, see annex DK Cable junction boxes
- sealable
- order cable glands, flanges and other accessories separately as required
- before connecting, aluminum conductors must be pre-treated according to the appropriate technical recommendations, see technical information aluminum conductors
- for normal environment and protected outdoor

rated insulation voltage	$U_i = 690 \text{ V a.c./d.c.}$
current carrying capacity	400 A
tightening torque for terminal	40.0 Nm
material	PC (polycarbonate)

IP  
65

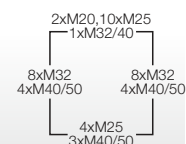
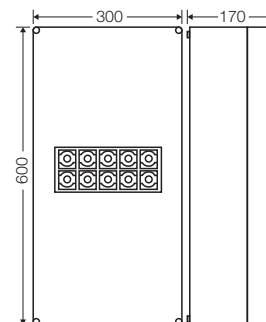

**DK Cable junction boxes**  
**With terminals for aluminum and copper conductors**  
**Cable entry via metric knockouts**



**K 2401**  
**35-240 mm², Cu/Alu 3~**

- with terminals
- 5-pole per pole 4 x 35-240 mm², conductors are inserted into the screw-type terminal, terminal technology, see annex DK Cable junction boxes
- sealable
- order cable glands, flanges and other accessories separately as required
- before connecting, aluminum conductors must be pre-treated according to the appropriate technical recommendations, see technical information aluminum conductors
- for normal environment and protected outdoor

IP  
65

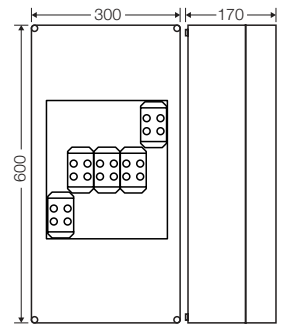

rated insulation voltage	$U_i = 690 \text{ V a.c./d.c.}$
current carrying capacity	
tightening torque for terminal material	26.0 Nm 35-120 mm² PC (polycarbonate)

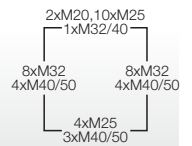

Before connecting, aluminum conductors must be pre-treated according to the appropriate technical recommendations



Conductor ends need to have the oxide layer carefully scraped clean.



Conductor ends need to be rubbed with an acid and alkali free grease and immediately connected

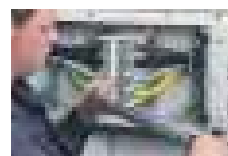

The terminals need to be tightened with the appropriate torque

12/7

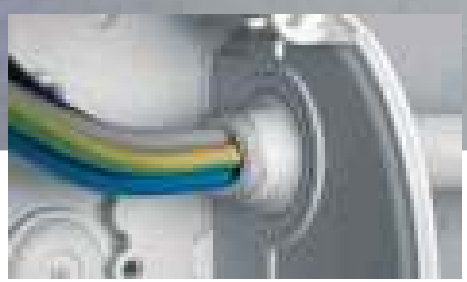

Reference table	
Present types	New types
D 9220	<b>DK 0200 R</b>
D 9225	<b>DK 0202 R</b> <b>DK 0402 R</b>
D 9240	<b>DK 0400 R</b>
D 9245	<b>DK 0404 R</b> <b>DK 0604 R</b>

**DK Cable junction boxes**

**for safety lighting circuits,  
for equipotential bonding conductors**

**Cable entry via integrated elastic membranes or metric knockouts**

- Cable junction box with red lid for safety lighting circuits
- With elastic membrane, which can be removed for cable entry via cable glands
- Multi-level knockouts for cable glands in different sizes
- Cable entry through the bottom of the box via integrated elastic membrane
- Closes quickly by a quarter turn - locked position well visible (open - locked)
- Lid fasteners sealable without accessories
- External brackets for wall fixing included
- Retaining strap, details see product description
- High-position terminals with more space for wiring
- All terminals with two clamping units per pole
- Every pole allows the connection of various conductor cross sections and conductor types
- Terminals prevent damage of conductors, also with flexible conductors without ferrule
- Different terminal positions and fastening options
- Material: polypropylene or polystyrene
- Burning behaviour: glow wire test in accordance with IEC 60695-2-11: 750 °C, flame-retardant, self-extinguishing
- Colour: grey RAL 7035, with red lid RAL 3000
- Terminal box for equipotential bonding cables

**DK Cable junction boxes**  
**For safety lighting circuits**  
**Cable entry via integrated elastic membranes or metric knockouts**



**DK 0202 R** NEW  
**1.5-2.5 mm<sup>2</sup>, Cu 3~**

- terminal with 2 clamping units per pole
- 5-pole per pole 8 x 0,75 mm<sup>2</sup> f, 6 x 1,5 mm<sup>2</sup> sol / f, 4 x 2,5 mm<sup>2</sup> sol / f, 2 x 4 mm<sup>2</sup> sol / f
- with red lid RAL 3000
- for safety lighting circuits
- with integrated elastic membranes, which can be removed for cable entry via cable glands, sealing range 6.0-15.0 mm
- with one cable entry in the bottom, sealing range Ø 6.0-13.0 mm
- lid fasteners sealable without accessories
- retaining strap and external brackets for wall fixing included

IP  
66

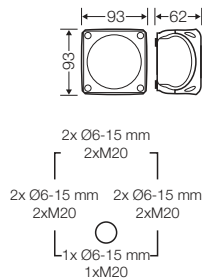

rated insulation voltage	U <sub>i</sub> = 690 V a.c./d.c.
current carrying capacity	20 A
tightening torque for terminal material	0.5 Nm
	PP (polypropylene)



**DK 0402 R** NEW  
**1.5-2.5 mm<sup>2</sup>, Cu 3~**

- terminal with 2 clamping units per pole
- 5-pole per pole 8 x 0,75 mm<sup>2</sup> f, 6 x 1,5 mm<sup>2</sup> sol / f, 4 x 2,5 mm<sup>2</sup> sol / f, 2 x 4 mm<sup>2</sup> sol / f
- with red lid RAL 3000
- for safety lighting circuits
- with elastic membranes, which can be removed for cable entry via cable glands, sealing range 9.0-17.0 mm
- with one cable entry in the bottom, sealing range Ø 6.0-15.0 mm
- lid fasteners sealable without accessories
- retaining strap and external brackets for wall fixing included

IP  
66

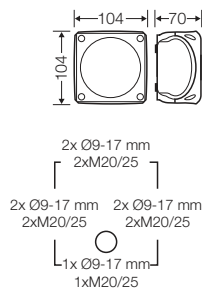

rated insulation voltage	U <sub>i</sub> = 690 V a.c./d.c.
current carrying capacity	20 A
tightening torque for terminal material	0.5 Nm
	PP (polypropylene)



**DK 0404 R** NEW  
**1.5-4 mm<sup>2</sup>, Cu 3~**

- terminal with 2 clamping units per pole
- 5-pole per pole 8 x 1,5 mm<sup>2</sup> sol / f, 6 x 2,5 mm<sup>2</sup> sol / f, 4 x 4 mm<sup>2</sup> sol / f, 2 x 6 mm<sup>2</sup> sol / f
- with red lid RAL 3000
- for safety lighting circuits
- with elastic membranes, which can be removed for cable entry via cable glands, sealing range 9.0-17.0 mm
- with one cable entry in the bottom, sealing range Ø 6.0-15.0 mm
- lid fasteners sealable without accessories
- retaining strap and external brackets for wall fixing included

IP  
66

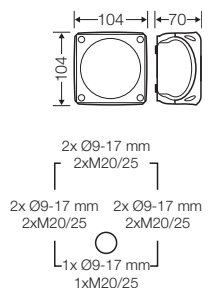

rated insulation voltage	U <sub>i</sub> = 690 V a.c./d.c.
current carrying capacity	32 A
tightening torque for terminal material	0.7 Nm
	PP (polypropylene)

**DK Cable junction boxes****For safety lighting circuits****Cable entry via integrated elastic membranes or metric knockouts****DK 0604 R** NEW**1.5-4 mm<sup>2</sup>, Cu 3~**

- terminal with 2 clamping units per pole
- 5-pole per pole 8 x 1,5 mm<sup>2</sup> sol / f, 6 x 2,5 mm<sup>2</sup> sol / f, 4 x 4 mm<sup>2</sup> sol / f, 2 x 6 mm<sup>2</sup> sol / f
- with red lid RAL 3000
- for safety lighting circuits
- with elastic membranes, which can be removed for cable entry via cable glands, sealing range 9.0-21.0 mm
- with one cable entry in the bottom, sealing range Ø 9.0-20.0 mm
- lid fasteners sealable without accessories
- retaining strap and external brackets for wall fixing included

IP
66

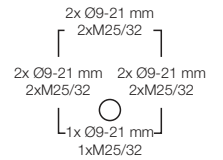
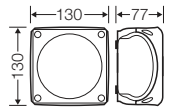

rated insulation voltage	$U_i = 690 \text{ V a.c./d.c.}$
current carrying capacity	32 A
tightening torque for terminal	0.7 Nm
material	PP (polypropylene)

**DK Cable junction boxes**

For safety lighting circuits

Cable entry via integrated elastic membranes or metric knockouts



**DK 0200 R** NEW

- without terminals
- with red lid RAL 3000
- for safety lighting circuits
- with integrated elastic membranes, which can be removed for cable entry via cable glands, sealing range 6.0-15.0 mm
- with one cable entry in the bottom, sealing range Ø 6.0-13.0 mm
- lid fasteners sealable without accessories
- retaining strap and external brackets for wall fixing included

material	PP (polypropylene)
----------	--------------------

IP  
66

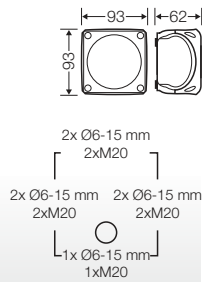

**DK 0400 R** NEW

- without terminals
- with red lid RAL 3000
- for safety lighting circuits
- with elastic membranes, which can be removed for cable entry via cable glands, sealing range 9.0-17.0 mm
- with one cable entry in the bottom, sealing range Ø 6.0-15.0 mm
- lid fasteners sealable without accessories
- retaining strap and external brackets for wall fixing included

material	PP (polypropylene)
----------	--------------------

IP  
66

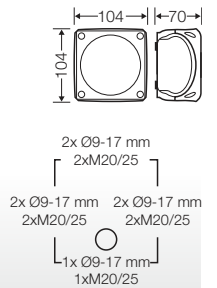

**DK Cable junction boxes**  
**For equipotential bonding conductors**  
**Cable entry via removable grommets**



**DP 9026**

**4-25 mm<sup>2</sup> / 4-10 mm<sup>2</sup>, Cu**

- with terminals
- 1-pole 1 x 4-25 mm<sup>2</sup>, 5 x 4-10 mm<sup>2</sup> (16 mm<sup>2</sup> sol)
- for equipotential bonding cables
- included cable entry: 4 DPS 02, sealing range Ø 10-13,5 mm
- for normal environment and protected outdoor

material

PS (Polystyrene)

IP  
54

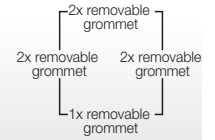
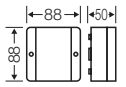

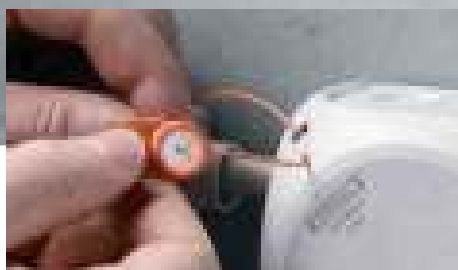

Reference table

Present types	New types
K 9259	<b>DK 2524 S</b>
K 9258	<b>DK 3525 S</b>
K 9509	<b>DK 3534 S</b>
K 9507	<b>DK 5035 S</b>
K 9508	omitted
K 9503	omitted

### DK Cable junction boxes

With main line branch terminal for copper conductors, sealable

Cable entry via metric knockouts

- Multi-level knockouts for cable glands in different sizes
- Cable entry through the bottom of the box via integrated elastic membrane
- Closes quickly by a quarter turn - locked position well visible (open - locked)
- lid fasteners sealable without accessories
- external brackets for wall fixing included
- Labelling system for circuit description
- Material: polycarbonate
- Burning behaviour: glow wire test in accordance with IEC 60695-2-11: 750 °C, flame-retardant, self-extinguishing
- Colour: grey, RAL 7035

**DK Cable junction boxes**

With main line branch terminals for copper conductors, sealable  
Cable entry via metric knockouts



**DK 2524 S** NEW

**6-25 mm<sup>2</sup>, Cu**

- with main line branch terminals for copper conductors
- 4-pole per pole terminals for incoming cables:  
10-25 mm<sup>2</sup> r, 6-16 mm<sup>2</sup> f, with end ferrule,  
terminals for outgoing cables:  
6-16 mm<sup>2</sup> r, 4-10 mm<sup>2</sup> with end ferrule
- lid fasteners sealable without accessories
- included cable entry: 3 ESM 40,  
sealing range Ø 17-30 mm
- with two cable entries M 32 from the rear side
- external brackets for wall fixing included

rated insulation voltage	U <sub>i</sub> = 400 V a.c.
current carrying capacity	80 A
tightening torque for terminal	3.0 Nm terminals for incoming cables 3.0 Nm terminals for outgoing cables
material	PC (polycarbonate)

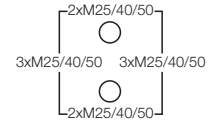
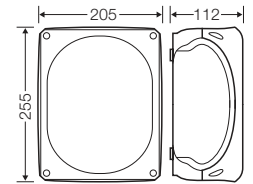

**DK 3525 S** NEW

**6-25 mm<sup>2</sup>, Cu**

- with main line branch terminals for copper conductors
- 5-pole, per pole terminals for incoming cables 10-25 mm<sup>2</sup> r,  
6-16 mm<sup>2</sup> f, with end ferrule,  
terminals for outgoing cables 6-16 mm<sup>2</sup> r, 4-10 mm<sup>2</sup> f  
with end ferrule
- lid fasteners sealable without accessories
- included cable entry: 3 ESM 40,  
sealing range Ø 17-30 mm
- with two cable entries M 32 from the rear side
- external brackets for wall fixing included

rated insulation voltage	U <sub>i</sub> = 400 V a.c.
current carrying capacity	80 A
tightening torque for terminal	3.0 Nm terminals for incoming cables 3.0 Nm terminals for outgoing cables
material	PC (polycarbonate)

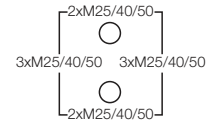
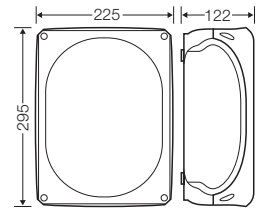

**DK Cable junction boxes**  
**With main line branch terminals for copper conductors, sealable**  
**Cable entry via metric knockouts**



**DK 3534 S** NEW

**6-35 mm<sup>2</sup>, Cu**

- with main line branch terminals for copper conductors
- 4-pole per pole terminals for incoming cables: 16-35 mm<sup>2</sup> r, 10-25 mm<sup>2</sup> f, with end ferrule, terminals for outgoing cables: 10-25 mm<sup>2</sup> r, 6-16 mm<sup>2</sup> f with end ferrule
- lid fasteners sealable without accessories
- cable entries via knockouts, order AKM separately (see cable entry systems LES)
- with two cable entries M 32 from the rear side
- external brackets for wall fixing included

rated insulation voltage	U <sub>i</sub> = 400 V a.c.
current carrying capacity	100 A
tightening torque for terminal	4.0 Nm terminals for incoming cables 3.0 Nm terminals for outgoing cables
material	PC (polycarbonate)

IP  
66

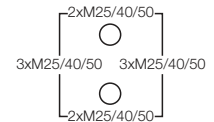
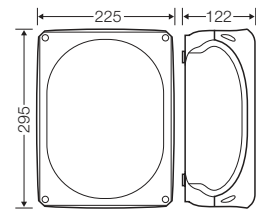

**DK 5035 S** NEW

**6-35 mm<sup>2</sup>, Cu**

- with main line branch terminals for copper conductors
- 5-pole per pole incoming terminals 16-35 mm<sup>2</sup> r, 10-25 mm<sup>2</sup> f, with end ferrule, outgoing cables 10-25 mm<sup>2</sup> r, 6-16 mm<sup>2</sup> f with end ferrule
- lid fasteners sealable without accessories
- cable entries via knockouts, order AKM separately (see cable entry systems LES)
- with two cable entries M 32 from the rear side
- external brackets for wall fixing included

rated insulation voltage	U <sub>i</sub> = 400 V a.c.
current carrying capacity	100 A
tightening torque for terminal	4.0 Nm terminals for incoming cables 3.0 Nm terminals for outgoing cables
material	PC (polycarbonate)

IP  
66

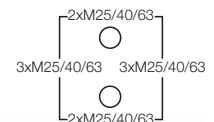
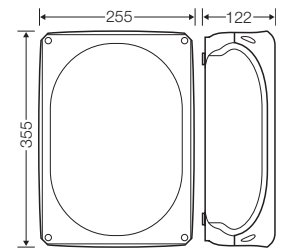

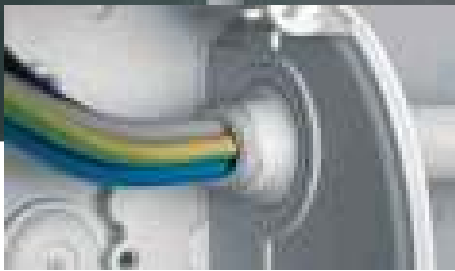

Reference table	
Present types	New types
RD 9123	<b>RK 0203 T</b>
RD 9125	<b>RK 0205 T</b>
RD 9127	<b>RK 0207 T</b>
RD 9045	<b>RK 0405 T</b>
RD 9041	<b>RK 0610 T</b>
RK 9062	<b>RK 0612 T</b>
RK 9064	<b>RK 0614 T</b>
RK 9109	<b>RK 1019 T</b>
RK 9104	<b>RK 1024 T</b>

### DK Cable junction boxes

**With terminal blocks for aluminum and copper conductors**

**Cable entry via integrated elastic membranes or metric knockouts**

- Terminal marking, neutral
- With elastic membrane, which can be removed for cable entry via cable glands
- Multi-level knockouts for cable glands in different sizes
- Cable entry through the bottom of the box via integrated elastic membrane
- Closes quickly by a quarter turn - locked position well visible (open - locked)
- Lid fasteners sealable without accessories
- External brackets for wall fixing included
- Retaining strap, details see product description
- Labelling system for circuit description
- All terminals with two clamping units per pole
- Terminals prevent damage of conductors, also with flexible conductors without ferrule
- Material: polypropylene
- Burning behaviour:  
glow wire test in accordance with IEC 60695-2-11: 750 °C,  
flame-retardant, self-extinguishing
- Colour: grey, RAL 7035

**DK Cable junction boxes**  
**With terminal blocks for aluminum and copper conductors**  
**Cable entry via integrated elastic membranes or metric knockouts**



**RK 0203 T** NEW

**1.5-2.5 mm<sup>2</sup>**

- 3 terminal blocks WKM 2.5/15
- per terminal 2 x 0,5-2,5 mm<sup>2</sup> f, 2 x 0,5-4 mm<sup>2</sup> sol or 2 x 1,5-2,5 mm<sup>2</sup> s, see Technical details for more information about terminal assignment
- terminal blocks, by Wieland
- for aluminium and copper conductors
- terminal marking, neutral
- with integrated elastic membranes, which can be removed for cable entry via cable glands, sealing range 6.0-15.0 mm
- with one cable entry in the bottom, sealing range Ø 6.0-13.0 mm
- lid fasteners sealable without accessories
- retaining strap and external brackets for wall fixing included

IP  
66

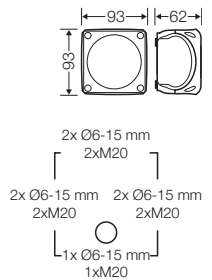

rated insulation voltage	U <sub>i</sub> = 500 V a.c./d.c.
current carrying capacity	24 A
tightening torque for terminal material	0,4 Nm PP (polypropylene)



**RK 0205 T** NEW

**1.5-2.5 mm<sup>2</sup>**

- 5 terminal blocks WKM 2.5/15
- per terminal 2 x 0,5-2,5 mm<sup>2</sup> f, 2 x 0,5-4 mm<sup>2</sup> sol or 2 x 1,5-2,5 mm<sup>2</sup> s, see Technical details for more information about terminal assignment
- terminal blocks, by Wieland
- for aluminium and copper conductors
- terminal marking, neutral
- with integrated elastic membranes, which can be removed for cable entry via cable glands, sealing range 6.0-15.0 mm
- with one cable entry in the bottom, sealing range Ø 6.0-13.0 mm
- lid fasteners sealable without accessories
- retaining strap and external brackets for wall fixing included

IP  
66

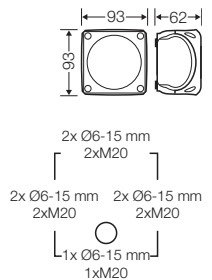

rated insulation voltage	U <sub>i</sub> = 500 V a.c./d.c.
current carrying capacity	24 A
tightening torque for terminal material	0,4 Nm PP (polypropylene)

**DK Cable junction boxes**

With terminal blocks for aluminum and copper conductors

Cable entry via integrated elastic membranes or metric knockouts



**RK 0207 T** NEW

**1.5-2.5 mm<sup>2</sup>**

- 7 terminal blocks WKM 2.5/15
- per terminal 2 x 0,5-2,5 mm<sup>2</sup> f, 2 x 0,5-4 mm<sup>2</sup> sol or 2 x 1,5-2,5 mm<sup>2</sup> s, see Technical details for more information about terminal assignment
- terminal blocks, by Wieland
- for aluminium and copper conductors
- terminal marking, neutral
- with integrated elastic membranes, which can be removed for cable entry via cable glands, sealing range 6.0-15.0 mm
- with one cable entry in the bottom, sealing range Ø 6.0-13.0 mm
- lid fasteners sealable without accessories
- retaining strap and external brackets for wall fixing included

IP  
66

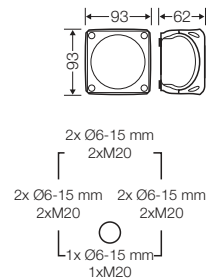

rated insulation voltage	U <sub>i</sub> = 500 V a.c./d.c.
current carrying capacity	24 A
tightening torque for terminal material	0,4 Nm PP (polypropylene)



**RK 0405 T** NEW

**1.5-4 mm<sup>2</sup>**

- 5 terminal blocks WKM 4/15
- per terminal 2 x 0,5-4 mm<sup>2</sup> f, 2 x 0,5-6 mm<sup>2</sup> sol or 2 x 1,5-4 mm<sup>2</sup> s, see Technical details DK cable junction boxes for more information about terminal assignment
- terminal blocks, by Wieland
- for aluminium and copper conductors
- terminal marking, neutral
- with elastic membranes, which can be removed for cable entry via cable glands, sealing range 9.0-17.0 mm
- with one cable entry in the bottom, sealing range Ø 6.0-15.0 mm
- lid fasteners sealable without accessories
- retaining strap and external brackets for wall fixing included

IP  
66

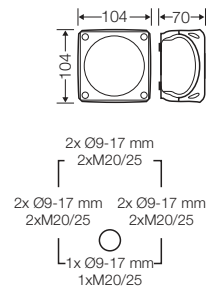

rated insulation voltage	U <sub>i</sub> = 500 V a.c./d.c.
current carrying capacity	28 A
tightening torque for terminal material	0.5 Nm PP (polypropylene)

**DK Cable junction boxes**

With terminal blocks for aluminum and copper conductors

Cable entry via integrated elastic membranes or metric knockouts



**RK 0610 T** NEW

**1.5-4 mm<sup>2</sup>**

- 10 terminal blocks WK 4/U
- per terminal 2 x 0,5-4 mm<sup>2</sup> f, 2 x 0,5-6 mm<sup>2</sup> sol or 2 x 1,5-4 mm<sup>2</sup> s, see Technical details DK cable junction boxes for more information about terminal assignment
- terminal blocks, by Wieland
- for aluminium and copper conductors
- terminal marking, neutral
- with elastic membranes, which can be removed for cable entry via cable glands, sealing range 9.0-21.0 mm
- with one cable entry in the bottom, sealing range Ø 9.0-20.0 mm
- lid fasteners sealable without accessories
- retaining strap and external brackets for wall fixing included

IP  
**66**

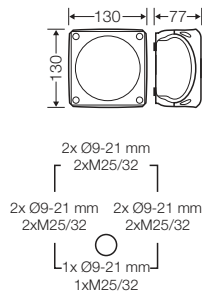

rated insulation voltage	U <sub>i</sub> = 690 V a.c./d.c.
current carrying capacity	41 A
tightening torque for terminal material	0.5 Nm PP (polypropylene)



**RK 0612 T** NEW

**1.5-4 mm<sup>2</sup>**

- 12 terminal blocks WK 4/U
- per terminal 2 x 0,5-4 mm<sup>2</sup> f, 2 x 0,5-6 mm<sup>2</sup> sol or 2 x 1,5-4 mm<sup>2</sup> s, see Technical details DK cable junction boxes for more information about terminal assignment
- terminal blocks, by Wieland
- for aluminium and copper conductors
- terminal marking, neutral
- with elastic membranes, which can be removed for cable entry via cable glands, sealing range 9.0-21.0 mm
- with one cable entry in the bottom, sealing range Ø 9.0-20.0 mm
- lid fasteners sealable without accessories
- retaining strap and external brackets for wall fixing included

IP  
**66**

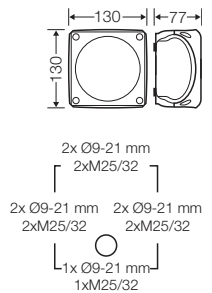

rated insulation voltage	U <sub>i</sub> = 690 V a.c./d.c.
current carrying capacity	41 A
tightening torque for terminal material	0.5 Nm PP (polypropylene)



**RK 0614 T** NEW

**1.5-4 mm<sup>2</sup>**

- 14 terminal blocks WK 4/U
- per terminal 2 x 0,5-4 mm<sup>2</sup> f, 2 x 0,5-6 mm<sup>2</sup> sol or 2 x 1,5-4 mm<sup>2</sup> s, see Technical details DK cable junction boxes for more information about terminal assignment
- terminal blocks, by Wieland
- for aluminium and copper conductors
- terminal marking, neutral
- with elastic membranes, which can be removed for cable entry via cable glands, sealing range 9.0-21.0 mm
- with one cable entry in the bottom, sealing range Ø 9.0-20.0 mm
- lid fasteners sealable without accessories
- retaining strap and external brackets for wall fixing included

IP  
**66**

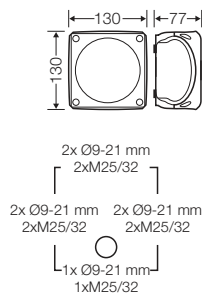

rated insulation voltage	U <sub>i</sub> = 690 V a.c./d.c.
current carrying capacity	41 A
tightening torque for terminal material	0.5 Nm PP (polypropylene)

**DK Cable junction boxes**

with terminal blocks for aluminum and copper conductors, cable entry via integrated elastic membranes or metric knockouts



**RK 1019 T** NEW

**1.5-4 mm<sup>2</sup>**

- 19 terminal blocks WK 4/U
- per terminal 2 x 0,5-4 mm<sup>2</sup> f, 2 x 0,5-6 mm<sup>2</sup> sol or 2 x 1,5-4 mm<sup>2</sup> s, see Technical details DK cable junction boxes for more information about terminal assignment
- terminal blocks, by Wieland
- for aluminium and copper conductors
- terminal marking, neutral
- with elastic membranes, which can be removed for cable entry via cable glands, sealing range 9.0-21.0 mm
- with two cable entries in the bottom, sealing range Ø 9.0-20.0 mm
- lid fasteners sealable without accessories
- retaining strap and external brackets for wall fixing included

IP  
66

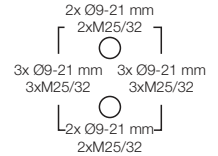
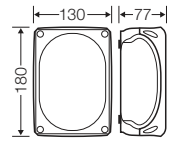

rated insulation voltage	$U_i = 690 \text{ V a.c./d.c.}$
current carrying capacity	41 A
tightening torque for terminal material	0.5 Nm
	PP (polypropylene)



**RK 1024 T** NEW

**1.5-4 mm<sup>2</sup>**

- 24 terminal blocks WK 4/U
- per terminal 2 x 0,5-4 mm<sup>2</sup> f, 2 x 0,5-6 mm<sup>2</sup> sol or 2 x 1,5-4 mm<sup>2</sup> s, see Technical details DK cable junction boxes for more information about terminal assignment
- terminal blocks, by Wieland
- for aluminium and copper conductors
- terminal marking, neutral
- with elastic membranes, which can be removed for cable entry via cable glands, sealing range 9.0-21.0 mm
- with two cable entries in the bottom, sealing range Ø 9.0-20.0 mm
- lid fasteners sealable without accessories
- retaining strap and external brackets for wall fixing included

IP  
66

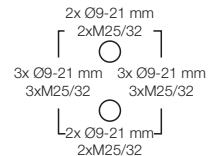
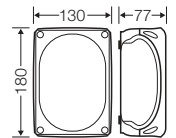

rated insulation voltage	$U_i = 690 \text{ V a.c./d.c.}$
current carrying capacity	41 A
tightening torque for terminal material	0.5 Nm
	PP (polypropylene)



Reference table	
Present types	New types
KF 9025	<b>KF 0202 G</b> <b>KF 0402 G</b>
KF 9045	<b>KF 0404 G</b> <b>KF 0604 G</b>
KF 9065	<b>KF 0606 G</b> <b>KF 1006 G</b>
KF 9105	<b>KF 1010 G</b> <b>KF 1610 G</b>
---	<b>KF 1616 G</b>
KF 9255	<b>KF 2525 G</b>
KF 9355	<b>KF 3535 G</b>
KF 9505	<b>KF 5050 G</b>
KF 9020	<b>KF 0200 G</b>
KF 9040	<b>KF 0400 G</b>
KF 9060	<b>KF 0600 G</b>
KF 9100	<b>KF 1000 G</b>
---	<b>KF 1600 G</b>
KF 9250	<b>KF 2500 G</b>
KF 9350	<b>KF 3500 G</b>
KF 9500	<b>KF 5000 G</b>
K 9350	<b>DK 3500 G</b>
K 9500	<b>DK 5000 G</b>

Reference table	
Present types	New types
KF 5025	<b>KF 0202 B</b>
KD 5025	<b>KF 0402 B</b>
KF 5045	<b>KF 0404 B</b>
KD 5045	<b>KF 0604 B</b>
KF 5065	<b>KF 0606 B</b>
KD 5065	<b>KF 1006 B</b>
KF 5105	<b>KF 1010 B</b>
KD 5105	<b>KF 1610 B</b>
---	<b>KF 1616 B</b>
KF 5255	<b>KF 2525 B</b>
KD 5255	<b>KF 2525 B</b>
KF 5355	<b>KF 3535 B</b>
KD 5355	<b>KF 3535 B</b>
KF 5505	<b>KF 5050 B</b>
KF 5020	<b>KF 0200 B</b>
KD 5020	<b>KF 0200 B</b>
KF 5040	<b>KF 0400 B</b>
KD 5040	<b>KF 0400 B</b>
KF 5060	<b>KF 0600 B</b>
KD 5060	<b>KF 0600 B</b>
KF 5100	<b>KF 1000 B</b>
KD 5100	<b>KF 1000 B</b>
---	<b>KF 1600 B</b>
KF 5250	<b>KF 2500 B</b>
KD 5250	<b>KF 2500 B</b>
KF 5350	<b>KF 3500 B</b>
KD 5350	<b>KF 3500 B</b>
KF 5500	<b>KF 5000 B</b>

Reference table	
Present types	New types
KF 5020	<b>KF 0200 B</b>
KD 5020	<b>KF 0200 B</b>
KF 5040	<b>KF 0400 B</b>
KD 5040	<b>KF 0400 B</b>
KF 5060	<b>KF 0600 B</b>
KD 5060	<b>KF 0600 B</b>
KF 5100	<b>KF 1000 B</b>
KD 5100	<b>KF 1000 B</b>
---	<b>KF 1600 B</b>
KF 5250	<b>KF 2500 B</b>
KD 5250	<b>KF 2500 B</b>
KF 5350	<b>KF 3500 B</b>
KD 5350	<b>KF 3500 B</b>
KF 5500	<b>KF 5000 B</b>
KF 8020	<b>KF 0200 H</b>
KF 8040	<b>KF 0400 H</b>
KF 8060	<b>KF 0600 H</b>
KF 8100	<b>KF 1000 H</b>
---	<b>KF 1600 H</b>
KF 8250	<b>KF 2500 H</b>
KF 8350	<b>KF 3500 H</b>
KF 8500	<b>KF 5000 H</b>

## DK Cable junction boxes

### “Weatherproof”, for outdoor installation

#### Cable entry via metric knockouts



- VDE tested, DNV GL - Certificate No.: TAE00000EE, Russian Maritime Register of Shipping documentation-No.: 250-A-1180-108795
- Closes quickly by a quarter turn - locked position well visible (open - locked)
- Degree of protection IP 66 / IP 67 / IP 69 with cable glands as accessories, temporary submersion up to 1 meter, max. 15 minutes
- cable entry through the bottom of the box via integrated elastic membrane
- High-position terminals with more space for wiring
- external brackets for wall fixing included
- Comply with the regulatory restrictions for buildings with requirements regarding the structural fire protection DIN VDE 0100 Part 482 (German Standard)
- Halogen-free: low toxicity, low fume development
- Weatherproof: UV-resistant, rainwater-proof, temperature-resistant
- Material: PC-GFS polycarbonate
- Burning behaviour: Glow wire test in accordance with IEC 60695-2-11: 960 °C, flame-retardant, self-extinguishing
- Colour: grey RAL 7035 or black RAL9011

**DK Cable junction boxes**  
 „Weatherproof“, for outdoor installation  
 Cable entry via metric knockouts



**KF 0202 G**

1.5-2.5 mm<sup>2</sup>, Cu 3~

- terminal with 2 clamping units per pole
- 5-pole per pole 8 x 0,75 mm<sup>2</sup> f, 6 x 1,5 mm<sup>2</sup> sol / f, 4 x 2,5 mm<sup>2</sup> sol / f, 2 x 4 mm<sup>2</sup> sol / f
- cable entries via knockouts, order AKM separately (see cable entry systems LES)
- "weatherproof" resistant to weather influences (UV due to solar radiation, protected against rainwater, temperature resistant, impact resistant, etc.)
- saltwater-proof
- "offshore applications"
- lid fasteners sealable without accessories
- retaining strap and external brackets for wall fixing included

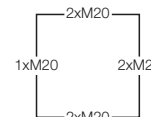
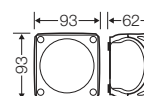

rated insulation voltage	U <sub>i</sub> = 690 V a.c./d.c.
current carrying capacity	20 A
tightening torque for terminal	0.5 Nm
material	PC-GFS (polycarbonate)



**KF 0402 G**

1.5-2.5 mm<sup>2</sup>, Cu 3~

- terminal with 2 clamping units per pole
- 5-pole per pole 8 x 0,75 mm<sup>2</sup> f, 6 x 1,5 mm<sup>2</sup> sol / f, 4 x 2,5 mm<sup>2</sup> sol / f, 2 x 4 mm<sup>2</sup> sol / f
- cable entries via knockouts, order AKM separately (see cable entry systems LES)
- "weatherproof" resistant to weather influences (UV due to solar radiation, protected against rainwater, temperature resistant, impact resistant, etc.)
- saltwater-proof
- "offshore applications"
- lid fasteners sealable without accessories
- retaining strap and external brackets for wall fixing included

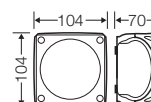

rated insulation voltage	U <sub>i</sub> = 690 V a.c./d.c.
current carrying capacity	20 A
tightening torque for terminal	0.5 Nm
material	PC-GFS (polycarbonate)



**KF 0404 G**

1.5-4 mm<sup>2</sup>, Cu 3~

- terminal with 2 clamping units per pole
- 5-pole per pole 8 x 1,5 mm<sup>2</sup> sol / f, 6 x 2,5 mm<sup>2</sup> sol / f, 4 x 4 mm<sup>2</sup> sol / f, 2 x 6 mm<sup>2</sup> sol / f
- cable entries via knockouts, order AKM separately (see cable entry systems LES)
- "weatherproof" resistant to weather influences (UV due to solar radiation, protected against rainwater, temperature resistant, impact resistant, etc.)
- saltwater-proof
- "offshore applications"
- lid fasteners sealable without accessories
- retaining strap and external brackets for wall fixing included

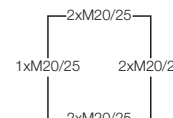
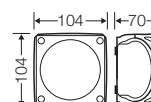

rated insulation voltage	U <sub>i</sub> = 690 V a.c./d.c.
current carrying capacity	32 A
tightening torque for terminal	0.7 Nm
material	PC-GFS (polycarbonate)

**DK Cable junction boxes**  
**„Weatherproof“, for outdoor installation**  
**Cable entry via metric knockouts**



**KF 0604 G**

**1.5-4 mm<sup>2</sup>, Cu 3~**

- terminal with 2 clamping units per pole
- 5-pole per pole 8 x 1,5 mm<sup>2</sup> sol / f, 6 x 2,5 mm<sup>2</sup> sol / f, 4 x 4 mm<sup>2</sup> sol / f, 2 x 6 mm<sup>2</sup> sol / f
- with one cable entry M 25 from the rear side
- cable entries via knockouts, order AKM separately (see cable entry systems LES)
- "weatherproof" resistant to weather influences (UV due to solar radiation, protected against rainwater, temperature resistant, impact resistant, etc.)
- saltwater-proof
- "offshore applications"
- lid fasteners sealable without accessories
- retaining strap and external brackets for wall fixing included

rated insulation voltage	U <sub>i</sub> = 690 V a.c./d.c.
current carrying capacity	32 A
tightening torque for terminal	0.7 Nm
material	PC-GFS (polycarbonate)

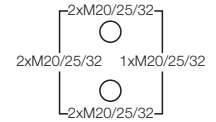
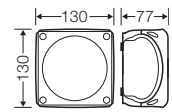

**KF 0606 G**

**2.5-6 mm<sup>2</sup>, Cu 3~**

- terminal with 2 clamping units per pole
- 5-pole per pole 6 x 1,5 mm<sup>2</sup> sol / f, 4 x 2,5 mm<sup>2</sup> sol / f, 4 x 4 mm<sup>2</sup> sol / f, 4 x 6 mm<sup>2</sup> sol / f, 2 x 10 mm<sup>2</sup> sol / f
- with one cable entry M 25 from the rear side
- cable entries via knockouts, order AKM separately (see cable entry systems LES)
- "weatherproof" resistant to weather influences (UV due to solar radiation, protected against rainwater, temperature resistant, impact resistant, etc.)
- saltwater-proof
- "offshore applications"
- lid fasteners sealable without accessories
- retaining strap and external brackets for wall fixing included

rated insulation voltage	U <sub>i</sub> = 690 V a.c./d.c.
current carrying capacity	40 A
tightening torque for terminal	1.5 Nm
material	PC-GFS (polycarbonate)

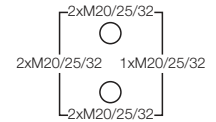
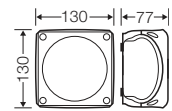

**DK Cable junction boxes**  
**„Weatherproof“, for outdoor installation**  
**Cable entry via metric knockouts**



**KF 1006 G**

**2.5-6 mm<sup>2</sup>, Cu 3~**

- terminal with 2 clamping units per pole
- 5-pole per pole 6 x 1,5 mm<sup>2</sup> sol / f, 4 x 2,5 mm<sup>2</sup> sol / f, 4 x 4 mm<sup>2</sup> sol / f, 4 x 6 mm<sup>2</sup> sol / f, 2 x 10 mm<sup>2</sup> sol / f
- with two cable entries M 25 from the rear side
- cable entries via knockouts, order AKM separately (see cable entry systems LES)
- "weatherproof" resistant to weather influences (UV due to solar radiation, protected against rainwater, temperature resistant, impact resistant, etc.)
- saltwater-proof
- "offshore applications"
- lid fasteners sealable without accessories
- retaining strap and external brackets for wall fixing included

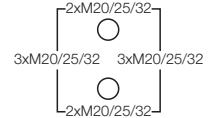
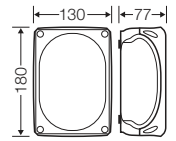

rated insulation voltage	U <sub>i</sub> = 690 V a.c./d.c.
current carrying capacity	40 A
tightening torque for terminal	1.5 Nm
material	PC-GFS (polycarbonate)



**KF 1010 G**

**4-10 mm<sup>2</sup>, Cu 3~**

- terminal with 2 clamping units per pole
- 5-pole per pole 6 x 2.5 mm<sup>2</sup> sol, 4 x 4 mm<sup>2</sup> sol, 4 x 6 mm<sup>2</sup> sol, 4 x 10 mm<sup>2</sup> sol, 2 x 16 mm<sup>2</sup> s
- with two cable entries M 25 from the rear side
- cable entries via knockouts, order AKM separately (see cable entry systems LES)
- "weatherproof" resistant to weather influences (UV due to solar radiation, protected against rainwater, temperature resistant, impact resistant, etc.)
- saltwater-proof
- "offshore applications"
- lid fasteners sealable without accessories
- retaining strap and external brackets for wall fixing included

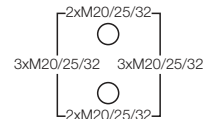
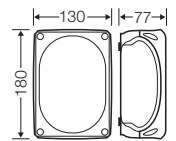

rated insulation voltage	U <sub>i</sub> = 690 V a.c./d.c.
current carrying capacity	63 A
tightening torque for terminal	2.0 Nm
material	PC-GFS (polycarbonate)

**DK Cable junction boxes**  
**„Weatherproof“, for outdoor installation**  
**Cable entry via metric knockouts**



**KF 1610 G**

**4-10 mm<sup>2</sup>, Cu 3~**

- terminal with 2 clamping units per pole
- 5-pole per pole 6 x 2.5 mm<sup>2</sup> sol, 4 x 4 mm<sup>2</sup> sol, 4 x 6 mm<sup>2</sup> sol, 4 x 10 mm<sup>2</sup> sol, 2 x 16 mm<sup>2</sup> s
- with two cable entries M 32 from the rear side
- cable entries via knockouts, order AKM separately (see cable entry systems LES)
- "weatherproof" resistant to weather influences (UV due to solar radiation, protected against rainwater, temperature resistant, impact resistant, etc.)
- saltwater-proof
- "offshore applications"
- lid fasteners sealable without accessories
- external brackets for wall fixing included

rated insulation voltage	U <sub>i</sub> = 690 V a.c./d.c.
current carrying capacity	63 A
tightening torque for terminal material	2.0 Nm PC-GFS (polycarbonate)

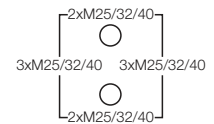
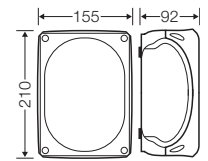

**KF 1616 G**

**10-16 mm<sup>2</sup>, Cu 3~**

- terminal with 2 clamping units per pole
- 5-pole per pole 6 x 6 mm<sup>2</sup> sol, 6 x 10 mm<sup>2</sup> sol/ f\*, 4 x 16 mm<sup>2</sup> s/ f\*, 4 x 25 mm<sup>2</sup> s/ f\*, 2 x 35 mm<sup>2</sup> s/ f\*  
f\* = with gas-tight end ferrule
- with two cable entries M 32 from the rear side
- cable entries via knockouts, order AKM separately (see cable entry systems LES)
- "weatherproof" resistant to weather influences (UV due to solar radiation, protected against rainwater, temperature resistant, impact resistant, etc.)
- saltwater-proof
- "offshore applications"
- lid fasteners sealable without accessories
- external brackets for wall fixing included

rated insulation voltage	U <sub>i</sub> = 690 V a.c./d.c.
current carrying capacity	102 A
tightening torque for terminal material	3.0 Nm PC-GFS (polycarbonate)

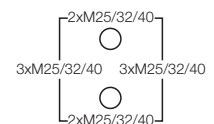
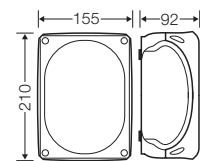

**DK Cable junction boxes**  
 „Weatherproof“, for outdoor installation  
 Cable entry via metric knockouts



**KF 2525 G**

**10-25 mm<sup>2</sup>, Cu 3~**

- terminal with 2 clamping units per pole
- 5-pole per pole 6 x 6 mm<sup>2</sup> sol, 6 x 10 mm<sup>2</sup> sol/ f\*, 4 x 16 mm<sup>2</sup> s/ f\*, 4 x 25 mm<sup>2</sup> s/ f\*, 2 x 35 mm<sup>2</sup> s/ f\*  
 f\* = with gas-tight end ferrule
- with two cable entries M 32 from the rear side
- cable entries via knockouts, order AKM separately (see cable entry systems LES)
- "weatherproof" resistant to weather influences (UV due to solar radiation, protected against rainwater, temperature resistant, impact resistant, etc.)
- saltwater-proof
- "offshore applications"
- lid fasteners sealable without accessories
- external brackets for wall fixing included

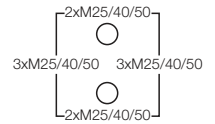
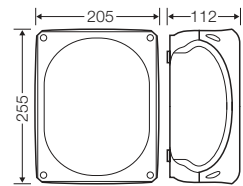

rated insulation voltage	U <sub>i</sub> = 690 V a.c./d.c.
current carrying capacity	102 A
tightening torque for terminal	3.0 Nm
material	PC-GFS (polycarbonate)



**KF 3535 G**

**16-35 mm<sup>2</sup>, Cu 3~**

- terminal with 2 clamping units per pole
- 5-pole per pole 6 x 16 mm<sup>2</sup> s, 4 x 25 mm<sup>2</sup> s, 4 x 35 mm<sup>2</sup> s, 2 x 50 mm<sup>2</sup> s
- with two cable entries M 32 from the rear side
- cable entries via knockouts, order AKM separately (see cable entry systems LES)
- "weatherproof" resistant to weather influences (UV due to solar radiation, protected against rainwater, temperature resistant, impact resistant, etc.)
- saltwater-proof
- "offshore applications"
- lid fasteners sealable without accessories
- external brackets for wall fixing included

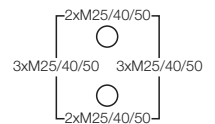
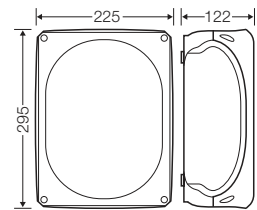

rated insulation voltage	U <sub>i</sub> = 690 V a.c./d.c.
current carrying capacity	125 A
tightening torque for terminal	12.0 Nm
material	PC-GFS (polycarbonate)

**DK Cable junction boxes**  
 „Weatherproof“, for outdoor installation  
 Cable entry via metric knockouts



**KF 5050 G**  
**16-50 mm<sup>2</sup>, Cu 3~**

- terminal with 2 clamping units per pole
- 5-pole per pole 6 x 16 mm<sup>2</sup> s, 4 x 25 mm<sup>2</sup> s, 4 x 35 mm<sup>2</sup> s, 4 x 50 mm<sup>2</sup> s
- with two cable entries M 32 from the rear side
- cable entries via knockouts, order AKM separately (see cable entry systems LES)
- "weatherproof" resistant to weather influences (UV due to solar radiation, protected against rainwater, temperature resistant, impact resistant, etc.)
- saltwater-proof
- "offshore applications"
- lid fasteners sealable without accessories
- external brackets for wall fixing included

rated insulation voltage	U <sub>i</sub> = 690 V a.c./d.c.
current carrying capacity	150 A
tightening torque for terminal material	12.0 Nm
	PC-GFS (polycarbonate)

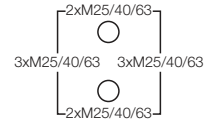
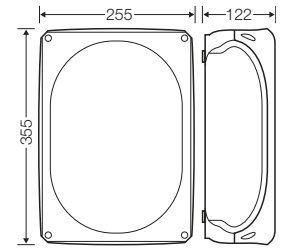

**DK Cable junction boxes**  
**„Weatherproof“, for outdoor installation**  
**Cable entry via metric knockouts**



**KF 0200 G**

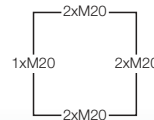
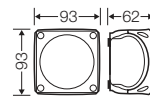

- without terminals
- cable entries via knockouts, order AKM separately (see cable entry systems LES)
- „weatherproof“ resistant to weather influences (UV due to solar radiation, protected against rainwater, temperature resistant, impact resistant, etc.)
- saltwater-proof
- "offshore applications"
- lid fasteners sealable without accessories
- retaining strap and external brackets for wall fixing included

material PC-GFS (polycarbonate)



**KF 0400 G**

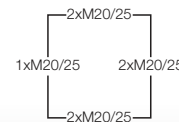
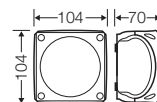

- without terminals
- cable entries via knockouts, order AKM separately (see cable entry systems LES)
- „weatherproof“ resistant to weather influences (UV due to solar radiation, protected against rainwater, temperature resistant, impact resistant, etc.)
- saltwater-proof
- "offshore applications"
- lid fasteners sealable without accessories
- retaining strap and external brackets for wall fixing included

material PC-GFS (polycarbonate)



**KF 0600 G**

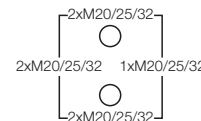
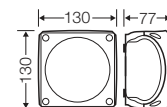

- without terminals
- with one cable entry M 25 from the rear side
- cable entries via knockouts, order AKM separately (see cable entry systems LES)
- „weatherproof“ resistant to weather influences (UV due to solar radiation, protected against rainwater, temperature resistant, impact resistant, etc.)
- saltwater-proof
- "offshore applications"
- lid fasteners sealable without accessories
- retaining strap and external brackets for wall fixing included

material PC-GFS (polycarbonate)



**DK Cable junction boxes**  
**„Weatherproof“, for outdoor installation**  
**Cable entry via metric knockouts**



**KF 1000 G**

- without terminals
- with two cable entries M 25 from the rear side
- cable entries via knockouts, order AKM separately (see cable entry systems LES)
- „weatherproof“ resistant to weather influences (UV due to solar radiation, protected against rainwater, temperature resistant, impact resistant, etc.)
- saltwater-proof
- "offshore applications"
- lid fasteners sealable without accessories
- retaining strap and external brackets for wall fixing included

material | PC-GFS (polycarbonate)

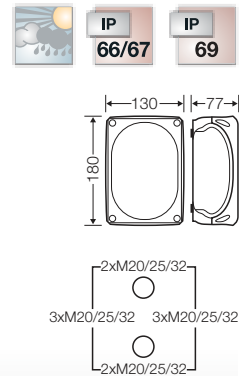

**KF 1600 G**

- without terminals
- with two cable entries M 32 from the rear side
- cable entries via knockouts, order AKM separately (see cable entry systems LES)
- „weatherproof“ resistant to weather influences (UV due to solar radiation, protected against rainwater, temperature resistant, impact resistant, etc.)
- saltwater-proof
- "offshore applications"
- lid fasteners sealable without accessories
- external brackets for wall fixing included

material | PC-GFS (polycarbonate)

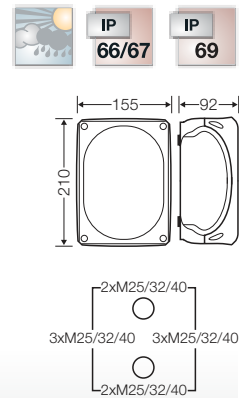

**KF 2500 G**

- without terminals
- with two cable entries M 32 from the rear side
- cable entries via knockouts, order AKM separately (see cable entry systems LES)
- „weatherproof“ resistant to weather influences (UV due to solar radiation, protected against rainwater, temperature resistant, impact resistant, etc.)
- saltwater-proof
- "offshore applications"
- lid fasteners sealable without accessories
- external brackets for wall fixing included

material | PC-GFS (polycarbonate)

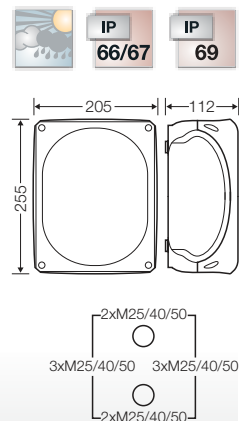

**DK Cable junction boxes**  
**„Weatherproof“, for outdoor installation**  
**Cable entry via metric knockouts**



**KF 3500 G**

- without terminals
- with two cable entries M 32 from the rear side
- cable entries via knockouts, order AKM separately (see cable entry systems LES)
- „weatherproof“ resistant to weather influences (UV due to solar radiation, protected against rainwater, temperature resistant, impact resistant, etc.)
- saltwater-proof
- "offshore applications"
- lid fasteners sealable without accessories
- external brackets for wall fixing included

material PC-GFS (polycarbonate)

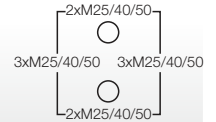
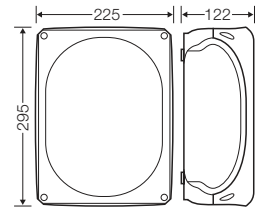

**KF 5000 G**

- without terminals
- with two cable entries M 32 from the rear side
- cable entries via knockouts, order AKM separately (see cable entry systems LES)
- „weatherproof“ resistant to weather influences (UV due to solar radiation, protected against rainwater, temperature resistant, impact resistant, etc.)
- saltwater-proof
- "offshore applications"
- lid fasteners sealable without accessories
- external brackets for wall fixing included

material PC-GFS (polycarbonate)

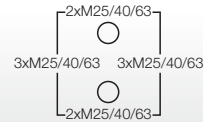
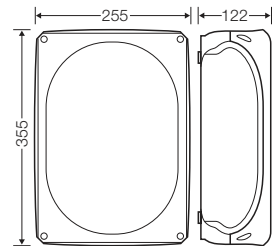

**DK Cable junction boxes**  
**„Weatherproof“, for outdoor installation**  
**Cable entry via metric knockouts**



**KF 0202 B**  
**1.5-2.5 mm<sup>2</sup>, Cu 3~**

- terminal with 2 clamping units per pole
- 5-pole per pole 8 x 0,75 mm<sup>2</sup> f, 6 x 1,5 mm<sup>2</sup> sol / f, 4 x 2,5 mm<sup>2</sup> sol / f, 2 x 4 mm<sup>2</sup> sol / f
- cable entries via knockouts, order ASS separately (see cable entry systems LES)
- „weatherproof“ resistant to weather influences (UV due to solar radiation, protected against rainwater, temperature resistant, impact resistant, etc.)
- saltwater-proof
- "offshore applications"
- lid fasteners sealable without accessories
- retaining strap and external brackets for wall fixing included

rated insulation voltage	U <sub>i</sub> = 690 V a.c./d.c.
current carrying capacity	20 A
tightening torque for terminal	0.5 Nm
material	PC-GFS (polycarbonate)

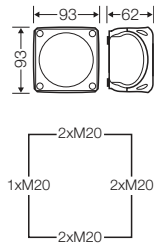

**KF 0402 B**  
**1.5-2.5 mm<sup>2</sup>, Cu 3~**

- terminal with 2 clamping units per pole
- 5-pole per pole 8 x 0,75 mm<sup>2</sup> f, 6 x 1,5 mm<sup>2</sup> sol / f, 4 x 2,5 mm<sup>2</sup> sol / f, 2 x 4 mm<sup>2</sup> sol / f
- cable entries via knockouts, order ASS separately (see cable entry systems LES)
- „weatherproof“ resistant to weather influences (UV due to solar radiation, protected against rainwater, temperature resistant, impact resistant, etc.)
- saltwater-proof
- "offshore applications"
- lid fasteners sealable without accessories
- retaining strap and external brackets for wall fixing included

rated insulation voltage	U <sub>i</sub> = 690 V a.c./d.c.
current carrying capacity	20 A
tightening torque for terminal	0.5 Nm
material	PC-GFS (polycarbonate)

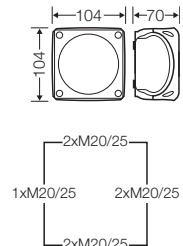

**KF 0404 B**  
**1.5-4 mm<sup>2</sup>, Cu 3~**

- terminal with 2 clamping units per pole
- 5-pole per pole 8 x 1,5 mm<sup>2</sup> sol / f, 6 x 2,5 mm<sup>2</sup> sol / f, 4 x 4 mm<sup>2</sup> sol / f, 2 x 6 mm<sup>2</sup> sol / f
- cable entries via knockouts, order ASS separately (see cable entry systems LES)
- „weatherproof“ resistant to weather influences (UV due to solar radiation, protected against rainwater, temperature resistant, impact resistant, etc.)
- saltwater-proof
- "offshore applications"
- lid fasteners sealable without accessories
- retaining strap and external brackets for wall fixing included

rated insulation voltage	U <sub>i</sub> = 690 V a.c./d.c.
current carrying capacity	32 A
tightening torque for terminal	0.7 Nm
material	PC-GFS (polycarbonate)

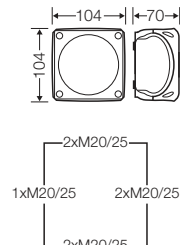

**DK Cable junction boxes**  
**„Weatherproof“, for outdoor installation**  
**Cable entry via metric knockouts**



**KF 0604 B**

**1.5-4 mm<sup>2</sup>, Cu 3~**

- terminal with 2 clamping units per pole
- 5-pole per pole 8 x 1,5 mm<sup>2</sup> sol / f, 6 x 2,5 mm<sup>2</sup> sol / f, 4 x 4 mm<sup>2</sup> sol / f, 2 x 6 mm<sup>2</sup> sol / f
- with one cable entry M 25 from the rear side
- cable entries via knockouts, order ASS separately (see cable entry systems LES)
- „weatherproof“ resistant to weather influences (UV due to solar radiation, protected against rainwater, temperature resistant, impact resistant, etc.)
- saltwater-proof
- "offshore applications"
- lid fasteners sealable without accessories
- retaining strap and external brackets for wall fixing included

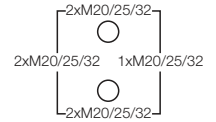
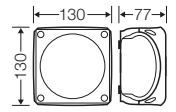

rated insulation voltage	U <sub>i</sub> = 690 V a.c./d.c.
current carrying capacity	32 A
tightening torque for terminal material	0.7 Nm PC-GFS (polycarbonate)



**KF 0606 B**

**2.5-6 mm<sup>2</sup>, Cu 3~**

- terminal with 2 clamping units per pole
- 5-pole per pole 6 x 1,5 mm<sup>2</sup> sol / f, 4 x 2,5 mm<sup>2</sup> sol / f, 4 x 4 mm<sup>2</sup> sol / f, 4 x 6 mm<sup>2</sup> sol / f, 2 x 10 mm<sup>2</sup> sol / f
- with one cable entry M 25 from the rear side
- cable entries via knockouts, order ASS separately (see cable entry systems LES)
- „weatherproof“ resistant to weather influences (UV due to solar radiation, protected against rainwater, temperature resistant, impact resistant, etc.)
- saltwater-proof
- "offshore applications"
- lid fasteners sealable without accessories
- retaining strap and external brackets for wall fixing included

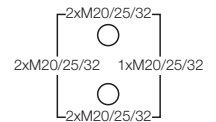
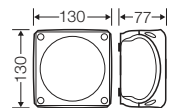

rated insulation voltage	U <sub>i</sub> = 690 V a.c./d.c.
current carrying capacity	40 A
tightening torque for terminal material	1.5 Nm PC-GFS (polycarbonate)

**DK Cable junction boxes**  
**„Weatherproof“, for outdoor installation**  
**Cable entry via metric knockouts**



**KF 1006 B**  
**2.5-6 mm<sup>2</sup>, Cu 3~**

- terminal with 2 clamping units per pole
- 5-pole per pole 6 x 1,5 mm<sup>2</sup> sol / f, 4 x 2,5 mm<sup>2</sup> sol / f, 4 x 4 mm<sup>2</sup> sol / f, 4 x 6 mm<sup>2</sup> sol / f, 2 x 10 mm<sup>2</sup> sol / f
- with two cable entries M 25 from the rear side
- cable entries via knockouts, order ASS separately (see cable entry systems LES)
- „weatherproof“ resistant to weather influences (UV due to solar radiation, protected against rainwater, temperature resistant, impact resistant, etc.)
- saltwater-proof
- "offshore applications"
- lid fasteners sealable without accessories
- retaining strap and external brackets for wall fixing included

rated insulation voltage	U <sub>i</sub> = 690 V a.c./d.c.
current carrying capacity	40 A
tightening torque for terminal material	1.5 Nm PC-GFS (polycarbonate)

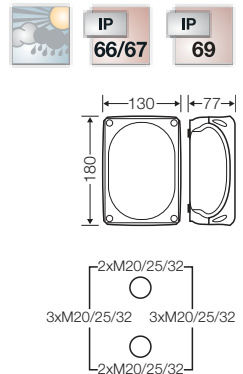

**KF 1010 B**  
**4-10 mm<sup>2</sup>, Cu 3~**

- terminal with 2 clamping units per pole
- 5-pole per pole 6 x 2.5 mm<sup>2</sup> sol, 4 x 4 mm<sup>2</sup> sol, 4 x 6 mm<sup>2</sup> sol, 4 x 10 mm<sup>2</sup> sol, 2 x 16 mm<sup>2</sup> s
- with two cable entries M 25 from the rear side
- cable entries via knockouts, order ASS separately (see cable entry systems LES)
- „weatherproof“ resistant to weather influences (UV due to solar radiation, protected against rainwater, temperature resistant, impact resistant, etc.)
- saltwater-proof
- "offshore applications"
- lid fasteners sealable without accessories
- retaining strap and external brackets for wall fixing included

rated insulation voltage	U <sub>i</sub> = 690 V a.c./d.c.
current carrying capacity	63 A
tightening torque for terminal material	2.0 Nm PC-GFS (polycarbonate)

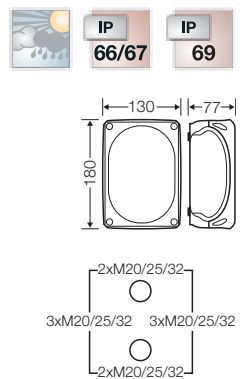



**DK Cable junction boxes**  
 „Weatherproof“, for outdoor installation  
 Cable entry via metric knockouts

**KF 1610 B**

**4-10 mm<sup>2</sup>, Cu 3~**

- terminal with 2 clamping units per pole
- 5-pole per pole 6 x 2.5 mm<sup>2</sup> sol, 4 x 4 mm<sup>2</sup> sol, 4 x 6 mm<sup>2</sup> sol, 4 x 10 mm<sup>2</sup> sol, 2 x 16 mm<sup>2</sup> s
- with two cable entries M 32 from the rear side
- cable entries via knockouts, order ASS separately (see cable entry systems LES)
- „weatherproof“ resistant to weather influences (UV due to solar radiation, protected against rainwater, temperature resistant, impact resistant, etc.)
- saltwater-proof
- "offshore applications"
- lid fasteners sealable without accessories
- external brackets for wall fixing included

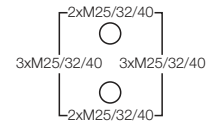
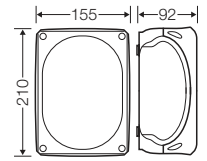

rated insulation voltage	U <sub>i</sub> = 690 V a.c./d.c.
current carrying capacity	63 A
tightening torque for terminal	2.0 Nm
material	PC-GFS (polycarbonate)



**KF 1616 B**

**10-16 mm<sup>2</sup>, Cu 3~**

- terminal with 2 clamping units per pole
- 5-pole per pole 6 x 6 mm<sup>2</sup> sol, 6 x 10 mm<sup>2</sup> sol/ f\*, 4 x 16 mm<sup>2</sup> s/ f\*, 4 x 25 mm<sup>2</sup> s/ f\*, 2 x 35 mm<sup>2</sup> s/ f\*  
 f\* = with gas-tight end ferrule
- with two cable entries M 32 from the rear side
- cable entries via knockouts, order ASS separately (see cable entry systems LES)
- „weatherproof“ resistant to weather influences (UV due to solar radiation, protected against rainwater, temperature resistant, impact resistant, etc.)
- saltwater-proof
- "offshore applications"
- lid fasteners sealable without accessories
- external brackets for wall fixing included

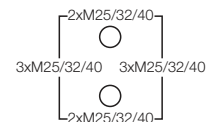
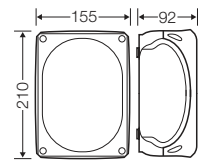

rated insulation voltage	U <sub>i</sub> = 690 V a.c./d.c.
current carrying capacity	102 A
tightening torque for terminal	3.0 Nm
material	PC-GFS (polycarbonate)

**DK Cable junction boxes**  
 „Weatherproof“, for outdoor installation  
 Cable entry via metric knockouts



**KF 2525 B**  
 10-25 mm<sup>2</sup>, Cu 3~

- terminal with 2 clamping units per pole
- 5-pole per pole 6 x 6 mm<sup>2</sup> sol, 6 x 10 mm<sup>2</sup> sol/ f\*, 4 x 16 mm<sup>2</sup> s/ f\*, 4 x 25 mm<sup>2</sup> s/ f\*, 2 x 35 mm<sup>2</sup> s/ f\*  
 f\* = with gas-tight end ferrule
- with two cable entries M 32 from the rear side
- cable entries via knockouts, order ASS separately (see cable entry systems LES)
- „weatherproof“ resistant to weather influences (UV due to solar radiation, protected against rainwater, temperature resistant, impact resistant, etc.)
- saltwater-proof
- "offshore applications"
- lid fasteners sealable without accessories
- external brackets for wall fixing included

rated insulation voltage	U <sub>i</sub> = 690 V a.c./d.c.
current carrying capacity	102 A
tightening torque for terminal	3.0 Nm
material	PC-GFS (polycarbonate)

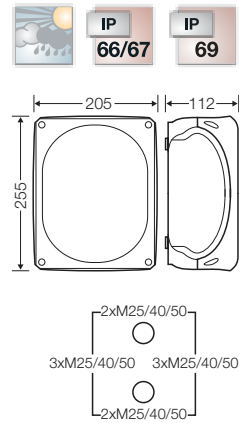

**KF 3535 B**  
 16-35 mm<sup>2</sup>, Cu 3~

- terminal with 2 clamping units per pole
- 5-pole per pole 6 x 16 mm<sup>2</sup> s, 4 x 25 mm<sup>2</sup> s, 4 x 35 mm<sup>2</sup> s, 2 x 50 mm<sup>2</sup> s
- with two cable entries M 32 from the rear side
- cable entries via knockouts, order ASS separately (see cable entry systems LES)
- „weatherproof“ resistant to weather influences (UV due to solar radiation, protected against rainwater, temperature resistant, impact resistant, etc.)
- saltwater-proof
- "offshore applications"
- lid fasteners sealable without accessories
- external brackets for wall fixing included

rated insulation voltage	U <sub>i</sub> = 690 V a.c./d.c.
current carrying capacity	125 A
tightening torque for terminal	12.0 Nm
material	PC-GFS (polycarbonate)

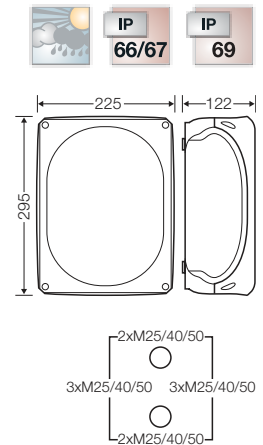



**DK Cable junction boxes**  
 „Weatherproof“, for outdoor installation  
 Cable entry via metric knockouts

**KF 5050 B**  
**16-50 mm<sup>2</sup>, Cu 3~**

- terminal with 2 clamping units per pole
- 5-pole per pole 6 x 16 mm<sup>2</sup> s, 4 x 25 mm<sup>2</sup> s, 4 x 35 mm<sup>2</sup> s, 4 x 50 mm<sup>2</sup> s
- with two cable entries M 32 from the rear side
- cable entries via knockouts, order ASS separately (see cable entry systems LES)
- „weatherproof“ resistant to weather influences (UV due to solar radiation, protected against rainwater, temperature resistant, impact resistant, etc.)
- saltwater-proof
- "offshore applications"
- lid fasteners sealable without accessories
- external brackets for wall fixing included

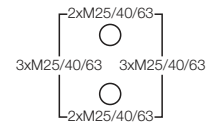
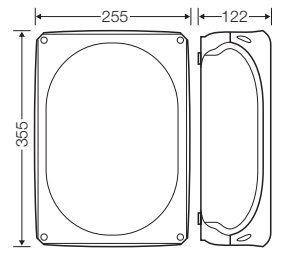

rated insulation voltage	U <sub>i</sub> = 690 V a.c./d.c.
current carrying capacity	150 A
tightening torque for terminal material	12.0 Nm
	PC-GFS (polycarbonate)

**DK Cable junction boxes**  
**„Weatherproof“, for outdoor installation**  
**Cable entry via metric knockouts**



**KF 0200 B**

- without terminals
- cable entries via knockouts, order ASS separately (see cable entry systems LES)
- „weatherproof“ resistant to weather influences (UV due to solar radiation, protected against rainwater, temperature resistant, impact resistant, etc.)
- saltwater-proof
- "offshore applications"
- lid fasteners sealable without accessories
- retaining strap and external brackets for wall fixing included

material	PC-GFS (polycarbonate)
----------	------------------------

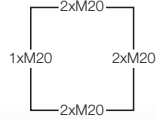
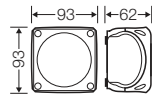

**KF 0400 B**

- without terminals
- cable entries via knockouts, order ASS separately (see cable entry systems LES)
- „weatherproof“ resistant to weather influences (UV due to solar radiation, protected against rainwater, temperature resistant, impact resistant, etc.)
- saltwater-proof
- "offshore applications"
- lid fasteners sealable without accessories
- retaining strap and external brackets for wall fixing included

material	PC-GFS (polycarbonate)
----------	------------------------

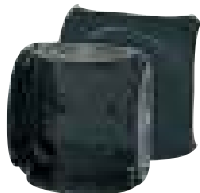
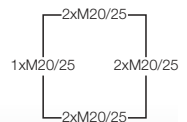
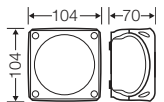

**KF 0600 B**

- without terminals
- with one cable entry M 25 from the rear side
- cable entries via knockouts, order ASS separately (see cable entry systems LES)
- „weatherproof“ resistant to weather influences (UV due to solar radiation, protected against rainwater, temperature resistant, impact resistant, etc.)
- saltwater-proof
- "offshore applications"
- lid fasteners sealable without accessories
- retaining strap and external brackets for wall fixing included

material	PC-GFS (polycarbonate)
----------	------------------------

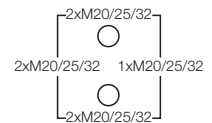
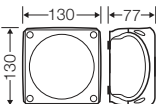

**DK Cable junction boxes**  
**„Weatherproof“, for outdoor installation**  
**Cable entry via metric knockouts**



**KF 1000 B**

- without terminals
- with two cable entries M 25 from the rear side
- cable entries via knockouts, order ASS separately (see cable entry systems LES)
- „weatherproof“ resistant to weather influences (UV due to solar radiation, protected against rainwater, temperature resistant, impact resistant, etc.)
- saltwater-proof
- "offshore applications"
- lid fasteners sealable without accessories
- retaining strap and external brackets for wall fixing included

material PC-GFS (polycarbonate)

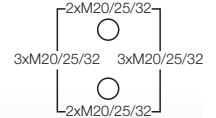
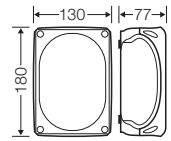

**KF 1600 B**

- without terminals
- with two cable entries M 32 from the rear side
- cable entries via knockouts, order ASS separately (see cable entry systems LES)
- „weatherproof“ resistant to weather influences (UV due to solar radiation, protected against rainwater, temperature resistant, impact resistant, etc.)
- saltwater-proof
- "offshore applications"
- lid fasteners sealable without accessories
- external brackets for wall fixing included

material PC-GFS (polycarbonate)

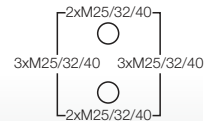
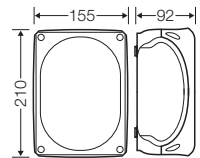

**KF 2500 B**

- without terminals
- with two cable entries M 32 from the rear side
- cable entries via knockouts, order ASS separately (see cable entry systems LES)
- „weatherproof“ resistant to weather influences (UV due to solar radiation, protected against rainwater, temperature resistant, impact resistant, etc.)
- saltwater-proof
- "offshore applications"
- lid fasteners sealable without accessories
- external brackets for wall fixing included

material PC-GFS (polycarbonate)

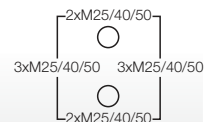
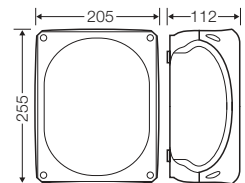

**DK Cable junction boxes**  
**„Weatherproof“, for outdoor installation**  
**Cable entry via metric knockouts**



**KF 3500 B**

- without terminals
- cable entries via knockouts, order ASS separately (see cable entry systems LES)
- with two cable entries M 32 from the rear side
- „weatherproof“ resistant to weather influences (UV due to solar radiation, protected against rainwater, temperature resistant, impact resistant, etc.)
- saltwater-proof
- "offshore applications"
- lid fasteners sealable without accessories
- external brackets for wall fixing included

material | PC-GFS (polycarbonate)

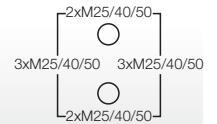
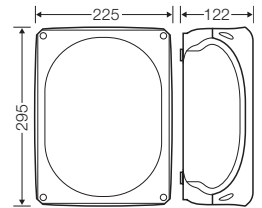

**KF 5000 B**

- without terminals
- with two cable entries M 32 from the rear side
- cable entries via knockouts, order ASS separately (see cable entry systems LES)
- „weatherproof“ resistant to weather influences (UV due to solar radiation, protected against rainwater, temperature resistant, impact resistant, etc.)
- saltwater-proof
- "offshore applications"
- lid fasteners sealable without accessories
- external brackets for wall fixing included

material | PC-GFS (polycarbonate)

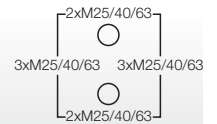
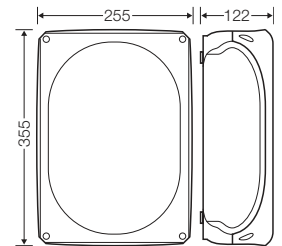



Reference table	
Present types	New types
KF 8020	<b>KF 0200 H</b>
KF 8040	<b>KF 0400 H</b>
KF 8060	<b>KF 0600 H</b>
KF 8100	<b>KF 1000 H</b>
---	<b>KF 1600 H</b>
KF 8250	<b>KF 2500 H</b>
KF 8350	<b>KF 3500 H</b>
KF 8500	<b>KF 5000 H</b>
KF 4020	<b>KF 0200 C</b>
KD 4020	
KF 4040	<b>KF 0400 C</b>
KD 4040	
KF 4060	<b>KF 0600 C</b>
KD 4060	
KF 4100	<b>KF 1000 C</b>
KD 4100	
---	<b>KF 1600 C</b>
KF 4250	<b>KF 2500 C</b>
KD 4250	
KF 4350	<b>KF 3500 C</b>
KD 4350	
KF 4500	<b>KF 5000 C</b>

**DK Cable junction boxes**

**”Weatherproof“ for outdoor installation**

**Box walls without knockouts**

- VDE tested, DNV GL - Certificate No.: TAE00000EE, Russian Maritime Register of Shipping dokumentation-No.: 250-A-1180-108795
- Cable entries can be drilled individually
- Closes quickly by a quarter turn - locked position well visible (open - locked)
- Degree of protection IP 66 / IP 67 with cable glands as accessories, temporary submersion up to 1 meter, max. 15 minutes
- cable entry through the bottom of the box via integrated elastic membrane
- High-position terminals with more space for wiring
- External brackets for wall fixing included
- Comply with the regulatory restrictions for buildings with requirements regarding the structural fire protection DIN VDE 0100 Part 482 (German Standard)
- Halogen-free: low toxicity, low fume development
- Weatherproof: UV-resistant, rainwater-proof, temperature-resistant
- Material: PC-GFS polycarbonate
- Burning behaviour: Glow wire test in accordance with IEC 60695-2-11: 960 °C, flame-retardant, self-extinguishing
- Colour: grey RAL 7035 or black RAL9011

**DK Cable junction boxes**  
**„Weatherproof“, for outdoor installation**  
**Box walls without knockouts**



**KF 0200 H**

- without terminals
- Box walls without knockouts
- wall surface can be drilled individually for cable entry max. M20
- „weatherproof“ resistant to weather influences (UV due to solar radiation, protected against rainwater, temperature resistant, impact resistant, etc.)
- saltwater-proof
- "offshore applications"
- lid fasteners sealable without accessories
- retaining strap and external brackets for wall fixing included

wall thickness of the bottom part material	2.0 mm PC-GFS (polycarbonate)
--	----------------------------------

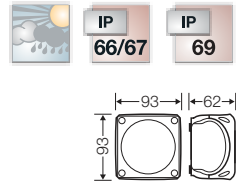

**KF 0400 H**

- without terminals
- Box walls without knockouts
- wall surface can be drilled individually for cable entry max. M25
- „weatherproof“ resistant to weather influences (UV due to solar radiation, protected against rainwater, temperature resistant, impact resistant, etc.)
- saltwater-proof
- "offshore applications"
- lid fasteners sealable without accessories
- retaining strap and external brackets for wall fixing included

wall thickness of the bottom part material	2.0 mm PC-GFS (polycarbonate)
--	----------------------------------

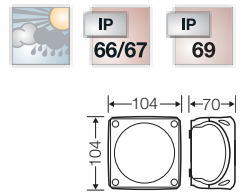

**KF 0600 H**

- without terminals
- Box walls without knockouts
- wall surface can be drilled individually for cable entry max. M32
- with one cable entry M 25 from the rear side
- „weatherproof“ resistant to weather influences (UV due to solar radiation, protected against rainwater, temperature resistant, impact resistant, etc.)
- saltwater-proof
- "offshore applications"
- lid fasteners sealable without accessories
- retaining strap and external brackets for wall fixing included

wall thickness of the bottom part material	2.0 mm PC-GFS (polycarbonate)
--	----------------------------------

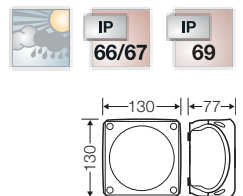

**DK Cable junction boxes**  
**„Weatherproof“, for outdoor installation**  
**Box walls without knockouts**



**KF 1000 H**

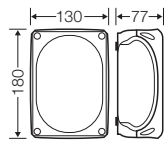

- without terminals
- Box walls without knockouts
- wall surface can be drilled individually for cable entry max. M32
- with two cable entries M 25 from the rear side
- „weatherproof“ resistant to weather influences (UV due to solar radiation, protected against rainwater, temperature resistant, impact resistant, etc.)
- saltwater-proof
- "offshore applications"
- lid fasteners sealable without accessories
- retaining strap and external brackets for wall fixing included



wall thickness of the bottom part material	2.0 mm PC-GFS (polycarbonate)
--	----------------------------------



**KF 1600 H**

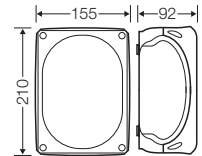

- without terminals
- Box walls without knockouts
- wall surface can be drilled individually for cable entry max. M40
- with two cable entries M 32 from the rear side
- „weatherproof“ resistant to weather influences (UV due to solar radiation, protected against rainwater, temperature resistant, impact resistant, etc.)
- saltwater-proof
- "offshore applications"
- lid fasteners sealable without accessories
- external brackets for wall fixing included



wall thickness of the bottom part material	2.6 mm PC-GFS (polycarbonate)
--	----------------------------------



**KF 2500 H**

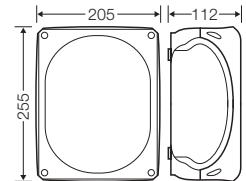

- without terminals
- Box walls without knockouts
- wall surface can be drilled individually for cable entry max. M50
- with two cable entries M 32 from the rear side
- „weatherproof“ resistant to weather influences (UV due to solar radiation, protected against rainwater, temperature resistant, impact resistant, etc.)
- saltwater-proof
- "offshore applications"
- lid fasteners sealable without accessories
- external brackets for wall fixing included



wall thickness of the bottom part material	2.7 mm PC-GFS (polycarbonate)
--	----------------------------------

**DK Cable junction boxes**  
**„Weatherproof“, for outdoor installation**  
**Box walls without knockouts**



**KF 3500 H**

- without terminals
- Box walls without knockouts
- wall surface can be drilled individually for cable entry max. M50
- with two cable entries M 32 from the rear side
- „weatherproof“ resistant to weather influences (UV due to solar radiation, protected against rainwater, temperature resistant, impact resistant, etc.)
- saltwater-proof
- "offshore applications"
- lid fasteners sealable without accessories
- external brackets for wall fixing included

wall thickness of the bottom part material	3.0 mm PC-GFS (polycarbonate)
--	----------------------------------

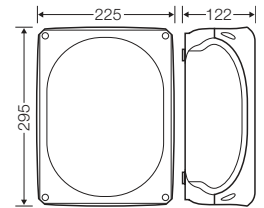

**KF 5000 H**

- without terminals
- Box walls without knockouts
- wall surface can be drilled individually for cable entry max. M63
- with two cable entries M 32 from the rear side
- „weatherproof“ resistant to weather influences (UV due to solar radiation, protected against rainwater, temperature resistant, impact resistant, etc.)
- saltwater-proof
- "offshore applications"
- lid fasteners sealable without accessories
- external brackets for wall fixing included

wall thickness of the bottom part material	3.2 mm PC-GFS (polycarbonate)
--	----------------------------------

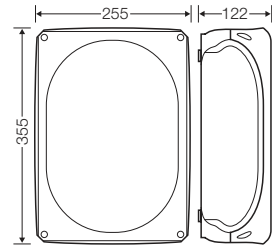

**DK Cable junction boxes**  
**„Weatherproof“, for outdoor installation**  
**Box walls without knockouts**



**KF 0200 C**

- without terminals
- Box walls without knockouts
- wall surface can be drilled individually for cable entry max. M20
- „weatherproof“ resistant to weather influences (UV due to solar radiation, protected against rainwater, temperature resistant, impact resistant, etc.)
- saltwater-proof
- "offshore applications"
- lid fasteners sealable without accessories
- retaining strap and external brackets for wall fixing included

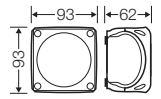

wall thickness of the bottom part	2.0 mm
material	PC-GFS (polycarbonate)



**KF 0400 C**

- without terminals
- Box walls without knockouts
- wall surface can be drilled individually for cable entry max. M25
- „weatherproof“ resistant to weather influences (UV due to solar radiation, protected against rainwater, temperature resistant, impact resistant, etc.)
- saltwater-proof
- "offshore applications"
- lid fasteners sealable without accessories
- retaining strap and external brackets for wall fixing included

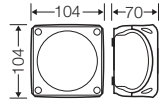

wall thickness of the bottom part	2.0 mm
material	PC-GFS (polycarbonate)



**KF 0600 C**

- without terminals
- Box walls without knockouts
- wall surface can be drilled individually for cable entry max. M32
- with one cable entry M 25 from the rear side
- „weatherproof“ resistant to weather influences (UV due to solar radiation, protected against rainwater, temperature resistant, impact resistant, etc.)
- saltwater-proof
- "offshore applications"
- lid fasteners sealable without accessories
- retaining strap and external brackets for wall fixing included

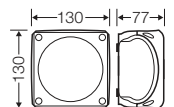

wall thickness of the bottom part	2.0 mm
material	PC-GFS (polycarbonate)

**DK Cable junction boxes**  
**„Weatherproof“, for outdoor installation**  
**Box walls without knockouts**



**KF 1000 C**

- without terminals
- Box walls without knockouts
- wall surface can be drilled individually for cable entry max. M32
- with two cable entries M 25 from the rear side
- „weatherproof“ resistant to weather influences (UV due to solar radiation, protected against rainwater, temperature resistant, impact resistant, etc.)
- saltwater-proof
- "offshore applications"
- lid fasteners sealable without accessories
- retaining strap and external brackets for wall fixing included

wall thickness of the bottom part material	2.0 mm PC-GFS (polycarbonate)
--	----------------------------------

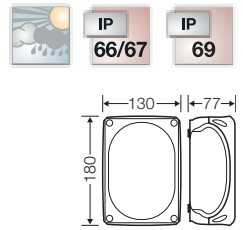

**KF 1600 C**

- without terminals
- Box walls without knockouts
- wall surface can be drilled individually for cable entry max. M40
- with two cable entries M 32 from the rear side
- „weatherproof“ resistant to weather influences (UV due to solar radiation, protected against rainwater, temperature resistant, impact resistant, etc.)
- saltwater-proof
- "offshore applications"
- lid fasteners sealable without accessories
- external brackets for wall fixing included

wall thickness of the bottom part material	2.6 mm PC-GFS (polycarbonate)
--	----------------------------------

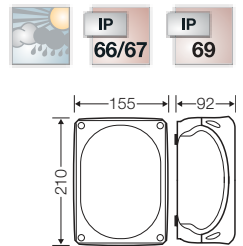

**KF 2500 C**

- without terminals
- Box walls without knockouts
- wall surface can be drilled individually for cable entry max. M50
- with two cable entries M 32 from the rear side
- „weatherproof“ resistant to weather influences (UV due to solar radiation, protected against rainwater, temperature resistant, impact resistant, etc.)
- saltwater-proof
- "offshore applications"
- lid fasteners sealable without accessories
- external brackets for wall fixing included

wall thickness of the bottom part material	2.7 mm PC-GFS (polycarbonate)
--	----------------------------------

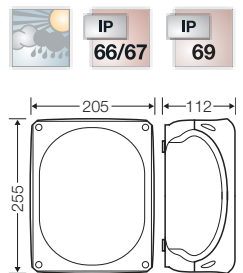

**DK Cable junction boxes**  
**„Weatherproof“, for outdoor installation**  
**Box walls without knockouts**



**KF 3500 C**

- without terminals
- Box walls without knockouts
- wall surface can be drilled individually for cable entry max. M50
- with two cable entries M 32 from the rear side
- „weatherproof“ resistant to weather influences (UV due to solar radiation, protected against rainwater, temperature resistant, impact resistant, etc.)
- saltwater-proof
- "offshore applications"
- lid fasteners sealable without accessories
- external brackets for wall fixing included

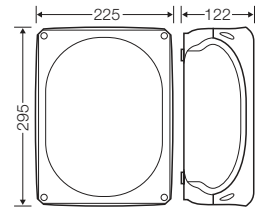

wall thickness of the bottom part material	3.0 mm PC-GFS (polycarbonate)
--	----------------------------------



**KF 5000 C**

- without terminals
- Box walls without knockouts
- wall surface can be drilled individually for cable entry max. M63
- with two cable entries M 32 from the rear side
- „weatherproof“ resistant to weather influences (UV due to solar radiation, protected against rainwater, temperature resistant, impact resistant, etc.)
- saltwater-proof
- "offshore applications"
- lid fasteners sealable without accessories
- external brackets for wall fixing included

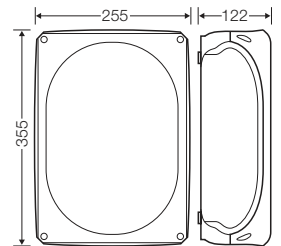

wall thickness of the bottom part material	3.2 mm PC-GFS (polycarbonate)
--	----------------------------------



Reference table

Present types	New types
KF WP 3025	WP 0202 G WP 0402 G
KF WP 3045	WP 0404 G WP 0604 G
KF WP 3065	WP 0606 G WP 1006 G
KF WP 3105	WP 1010 G
KF WP 2025	WP 0202 B WP 0402 B
KF WP 2045	WP 0404 B WP 0604 B
KF WP 2065	WP 0606 B WP 1006 B
KF WP 2105	WP 1010 B

### DK Cable junction boxes

#### "Waterproof", for encapsulating

for outdoor installation and use in harsh environmental conditions with risk of condensation and ingress of water as well as for installation in the ground without traffic loads

- By sealing cable junction boxes with a sealing compound the ingress of water and formation of condensation is completely prevented.
- After removing the lid the measuring can be carried out.
- In case of re-installation or testing the sealing compound can be removed easily
- Material: PC-GFS polycarbonate
- Burning behaviour: Glow wire test in accordance with IEC 60695-2-11: 960 °C, flame-retardant, self-extinguishing
- Colour: grey RAL 7035 or black RAL9011

**Permanent waterproof connection -  
 Cable junction boxes for encapsulating in accordance with DIN VDE V 0606-22-100**

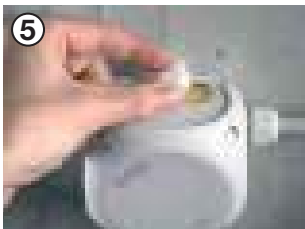
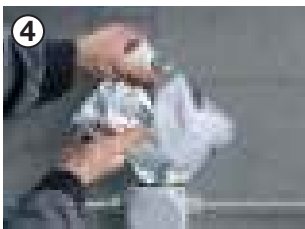
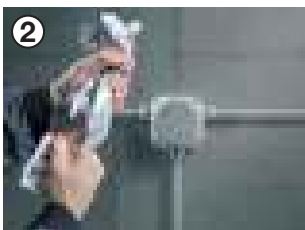
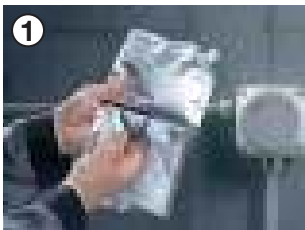

Time and time again, electricians come across installation environments whereby the ingress of water into an enclosure must be safely excluded. Even enclosures which have a high degree of protection cannot guarantee this. The IP degree of protection allows the ingress of non-harmful quantities of water in the interior of an enclosure. Under extreme environmental conditions, for example, the accumulation of condensation may result in damage to the electrical installation or devices or cause these to malfunction. Ventilation measures will often suffice to prevent harmful condensation from forming. In many cases, however, ventilation is not possible, e.g. because the cable junction boxes are installed close to rivers and water could enter through the vent holes.

**Which applications require waterproof connections?**

- Pump shafts
- Ground-level installation ducts in outdoor areas
- Flood areas close to rivers
- Unprotected outdoor installations which are in close proximity to the ground

**Why is the IP degree of protection alone not sufficient?**

- All degrees of protection allow water ingress
- The accumulation of condensation cannot always be prevented
- Ventilation measures cannot be applied in all environments

**The waterproof connection:**

Sealing the cable junction boxes with a fast setting, permanently elastic sealing compound completely prevents the ingress of water and excludes forming of condensation.

The sealing compound features outstanding insulation properties. As the compound is transparent, it is possible for visual inspections of the installation to be carried out at any time. The durable elastic material is self-sealing, therefore it is also easy for the electrical connections to be tested after they have been sealed.

The sealing compound can be easily removed for repairs, subsequent installations or changes to installations.

Another benefit: the sealed cable junction boxes also offer reliable protection against shock and vibration. The sealing compound does not, however, provide strain relief as it only adheres to material and does not stick together. Suitable cable entries must also be used here, e.g. Hensel AKM.



The ingress of water and formation of condensation are completely prevented. The sealing compound can be easily removed for subsequent installations or inspections.



**WP 0202 G**

**1.5-2.5 mm<sup>2</sup>, Cu 3~**

- with terminals
- 5-pole per pole 8 x 0,75 mm<sup>2</sup> f, 6 x 1,5 mm<sup>2</sup> sol / f, 4 x 2,5 mm<sup>2</sup> sol / f, 2 x 4 mm<sup>2</sup> sol / f
- cable entries via knockouts, order AKM separately (see cable entry systems LES)
- cable junction box for encapsulating
- for ground installation without live loads or in risk of condensation formation and ingress of liquids
- installation under water without chemical additives up to a depth of 1 meter possible in the long term
- usable for heating cable / heating tape up to max. 70 °C surface temperature
- with sealing compound and sealing plug
- in case of re-installation or testing the sealing compound can be removed easily
- durability of sealing compound to processing ≥ 12 months at a storage temperature of 5 - 35 °C
- external brackets for wall fixing included
- enclosure volume 350 ml

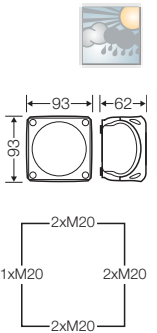

degree of protection	For totally encapsulated cable junction boxes the IP degrees of protection of enclosures according to DIN EN 60529 are not applicable.
rated insulation voltage	U <sub>i</sub> = 690 V a.c./d.c.
current carrying capacity	20 A
tightening torque for terminal	0.5 Nm
material	PC-GFS (polycarbonate)



**WP 0402 G**

**1.5-2.5 mm<sup>2</sup>, Cu 3~**

- with terminals
- 5-pole per pole 8 x 0,75 mm<sup>2</sup> f, 6 x 1,5 mm<sup>2</sup> sol / f, 4 x 2,5 mm<sup>2</sup> sol / f, 2 x 4 mm<sup>2</sup> sol / f
- cable entries via knockouts, order AKM separately (see cable entry systems LES)
- cable junction box for encapsulating
- for ground installation without live loads or in risk of condensation formation and ingress of liquids
- installation under water without chemical additives up to a depth of 1 meter possible in the long term
- usable for heating cable / heating tape up to max. 70 °C surface temperature
- with sealing compound and sealing plug
- in case of re-installation or testing the sealing compound can be removed easily
- durability of sealing compound to processing ≥ 12 months at a storage temperature of 5 - 35 °C
- external brackets for wall fixing included
- enclosure volume 500 ml

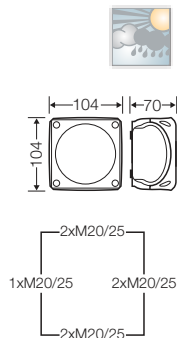

degree of protection	For totally encapsulated cable junction boxes the IP degrees of protection of enclosures according to DIN EN 60529 are not applicable.
rated insulation voltage	U <sub>i</sub> = 690 V a.c./d.c.
current carrying capacity	20 A
tightening torque for terminal	0.5 Nm
material	PC-GFS (polycarbonate)

**DK Cable junction boxes**  
**"Waterproof", for encapsulating**



**WP 0404 G**

**1.5-4 mm<sup>2</sup>, Cu 3~**

- with terminals
- 5-pole per pole 8 x 1,5 mm<sup>2</sup> sol / f, 6 x 2,5 mm<sup>2</sup> sol / f, 4 x 4 mm<sup>2</sup> sol / f, 2 x 6 mm<sup>2</sup> sol / f
- cable entries via knockouts, order AKM separately (see cable entry systems LES)
- cable junction box for encapsulating
- for ground installation without live loads or in risk of condensation formation and ingress of liquids
- installation under water without chemical additives up to a depth of 1 meter possible in the long term
- usable for heating cable / heating tape up to max. 70 °C surface temperature
- with sealing compound and sealing plug
- in case of re-installation or testing the sealing compound can be removed easily
- durability of sealing compound to processing  $\geq$  12 months at a storage temperature of 5 - 35 °C
- external brackets for wall fixing included
- enclosure volume 500 ml

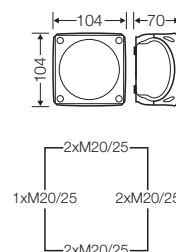

degree of protection	For totally encapsulated cable junction boxes the IP degrees of protection of enclosures according to DIN EN 60529 are not applicable.
rated insulation voltage	$U_i = 690$ V a.c./d.c.
current carrying capacity	32 A
tightening torque for terminal	0.7 Nm
material	PC-GFS (polycarbonate)



**WP 0604 G**

**1.5-4 mm<sup>2</sup>, Cu 3~**

- with terminals
- 5-pole per pole 8 x 1,5 mm<sup>2</sup> sol / f, 6 x 2,5 mm<sup>2</sup> sol / f, 4 x 4 mm<sup>2</sup> sol / f, 2 x 6 mm<sup>2</sup> sol / f
- cable entries via knockouts, order AKM separately (see cable entry systems LES)
- cable junction box for encapsulating
- for ground installation without live loads or in risk of condensation formation and ingress of liquids
- installation under water without chemical additives up to a depth of 1 meter possible in the long term
- usable for heating cable / heating tape up to max. 70 °C surface temperature
- with sealing compound and sealing plug
- in case of re-installation or testing the sealing compound can be removed easily
- durability of sealing compound to processing  $\geq$  12 months at a storage temperature of 5 - 35 °C
- external brackets for wall fixing included
- enclosure volume 850 ml

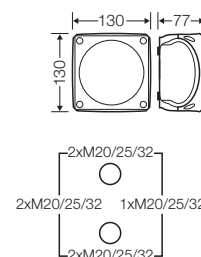

degree of protection	For totally encapsulated cable junction boxes the IP degrees of protection of enclosures according to DIN EN 60529 are not applicable.
rated insulation voltage	$U_i = 690$ V a.c./d.c.
current carrying capacity	32 A
tightening torque for terminal	0.7 Nm
material	PC-GFS (polycarbonate)



**WP 0606 G**  
**2.5-6 mm<sup>2</sup>, Cu 3~**

- with terminals
- 5-pole per pole 6 x 1,5 mm<sup>2</sup> sol / f, 4 x 2,5 mm<sup>2</sup> sol / f, 4 x 4 mm<sup>2</sup> sol / f, 4 x 6 mm<sup>2</sup> sol / f, 2 x 10 mm<sup>2</sup> sol / f
- cable entries via knockouts, order AKM separately (see cable entry systems LES)
- cable junction box for encapsulating
- for ground installation without live loads or in risk of condensation formation and ingress of liquids
- installation under water without chemical additives up to a depth of 1 meter possible in the long term
- usable for heating cable / heating tape up to max. 70 °C surface temperature
- with sealing compound and sealing plug
- in case of re-installation or testing the sealing compound can be removed easily
- durability of sealing compound to processing ≥ 12 months at a storage temperature of 5 - 35 °C
- external brackets for wall fixing included
- enclosure volume 850 ml

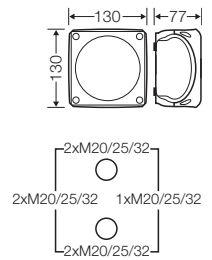

degree of protection	For totally encapsulated cable junction boxes the IP degrees of protection of enclosures according to DIN EN 60529 are not applicable.
rated insulation voltage	U <sub>i</sub> = 690 V a.c./d.c.
current carrying capacity	40 A
tightening torque for terminal	1.5 Nm
material	PC-GFS (polycarbonate)



**WP 1006 G**  
**2.5-6 mm<sup>2</sup>, Cu 3~**

- with terminals
- 5-pole per pole 6 x 1,5 mm<sup>2</sup> sol / f, 4 x 2,5 mm<sup>2</sup> sol / f, 4 x 4 mm<sup>2</sup> sol / f, 4 x 6 mm<sup>2</sup> sol / f, 2 x 10 mm<sup>2</sup> sol / f
- cable entries via knockouts, order AKM separately (see cable entry systems LES)
- cable junction box for encapsulating
- for ground installation without live loads or in risk of condensation formation and ingress of liquids
- installation under water without chemical additives up to a depth of 1 meter possible in the long term
- usable for heating cable / heating tape up to max. 70 °C surface temperature
- with sealing compound and sealing plug
- in case of re-installation or testing the sealing compound can be removed easily
- durability of sealing compound to processing ≥ 12 months at a storage temperature of 5 - 35 °C
- external brackets for wall fixing included
- enclosure volume 1200 ml

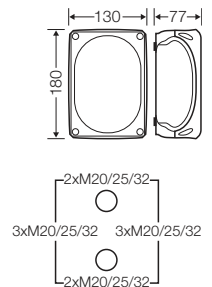

degree of protection	For totally encapsulated cable junction boxes the IP degrees of protection of enclosures according to DIN EN 60529 are not applicable.
rated insulation voltage	U <sub>i</sub> = 690 V a.c./d.c.
current carrying capacity	40 A
tightening torque for terminal	1.5 Nm
material	PC-GFS (polycarbonate)

**DK Cable junction boxes**  
**"Waterproof", for encapsulating**



**WP 1010 G**

**4-10 mm<sup>2</sup>, Cu 3~**

- with terminals
- 5-pole per pole 6 x 2.5 mm<sup>2</sup> sol, 4 x 4 mm<sup>2</sup> sol, 4 x 6 mm<sup>2</sup> sol, 4 x 10 mm<sup>2</sup> sol, 2 x 16 mm<sup>2</sup> s
- cable entries via knockouts, order AKM separately (see cable entry systems LES)
- cable junction box for encapsulating
- for ground installation without live loads or in risk of condensation formation and ingress of liquids
- installation under water without chemical additives up to a depth of 1 meter possible in the long term
- usable for heating cable / heating tape up to max. 70 °C surface temperature
- with sealing compound and sealing plug
- in case of re-installation or testing the sealing compound can be removed easily
- durability of sealing compound to processing ≥ 12 months at a storage temperature of 5 - 35 °C
- external brackets for wall fixing included
- enclosure volume 1200 ml

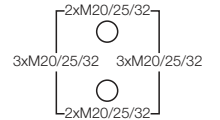
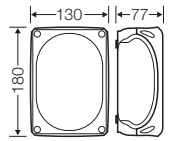

degree of protection	For totally encapsulated cable junction boxes the IP degrees of protection of enclosures according to DIN EN 60529 are not applicable.
rated insulation voltage	U <sub>i</sub> = 690 V a.c./d.c.
current carrying capacity	63 A
tightening torque for terminal	2.0 Nm
material	PC-GFS (polycarbonate)



**WP 0202 B**

**1.5-2.5 mm<sup>2</sup>, Cu 3~**

- with terminals
- 5-pole per pole 8 x 0,75 mm<sup>2</sup> f, 6 x 1,5 mm<sup>2</sup> sol / f, 4 x 2,5 mm<sup>2</sup> sol / f, 2 x 4 mm<sup>2</sup> sol / f
- cable entries via knockouts, order ASS separately (see cable entry systems LES)
- cable junction box for encapsulating
- for ground installation without live loads or in risk of condensation formation and ingress of liquids
- installation under water without chemical additives up to a depth of 1 meter possible in the long term
- usable for heating cable / heating tape up to max. 70 °C surface temperature
- with sealing compound and sealing plug
- in case of re-installation or testing the sealing compound can be removed easily
- durability of sealing compound to processing ≥ 12 months at a storage temperature of 5 - 35 °C
- external brackets for wall fixing included
- enclosure volume 350 ml

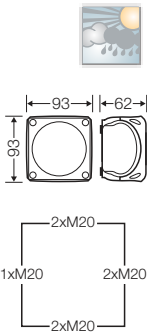

degree of protection	For totally encapsulated cable junction boxes the IP degrees of protection of enclosures according to DIN EN 60529 are not applicable.
rated insulation voltage	U <sub>i</sub> = 690 V a.c./d.c.
current carrying capacity	20 A
tightening torque for terminal	0.5 Nm
material	PC-GFS (polycarbonate)



**WP 0402 B**

**1.5-2.5 mm<sup>2</sup>, Cu 3~**

- with terminals
- 5-pole per pole 8 x 0,75 mm<sup>2</sup> f, 6 x 1,5 mm<sup>2</sup> sol / f, 4 x 2,5 mm<sup>2</sup> sol / f, 2 x 4 mm<sup>2</sup> sol / f
- cable entries via knockouts, order ASS separately (see cable entry systems LES)
- cable junction box for encapsulating
- for ground installation without live loads or in risk of condensation formation and ingress of liquids
- installation under water without chemical additives up to a depth of 1 meter possible in the long term
- usable for heating cable / heating tape up to max. 70 °C surface temperature
- with sealing compound and sealing plug
- in case of re-installation or testing the sealing compound can be removed easily
- durability of sealing compound to processing ≥ 12 months at a storage temperature of 5 - 35 °C
- external brackets for wall fixing included
- enclosure volume 500 ml

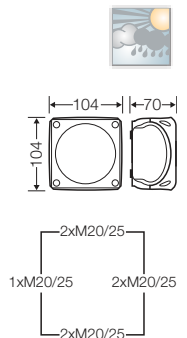

degree of protection	For totally encapsulated cable junction boxes the IP degrees of protection of enclosures according to DIN EN 60529 are not applicable.
rated insulation voltage	U <sub>i</sub> = 690 V a.c./d.c.
current carrying capacity	20 A
tightening torque for terminal	0.5 Nm
material	PC-GFS (polycarbonate)

**DK Cable junction boxes**  
**"Waterproof", for encapsulating**



**WP 0404 B**

**1.5-4 mm<sup>2</sup>, Cu 3~**

- with terminals
- 5-pole per pole 8 x 1,5 mm<sup>2</sup> sol / f, 6 x 2,5 mm<sup>2</sup> sol / f, 4 x 4 mm<sup>2</sup> sol / f, 2 x 6 mm<sup>2</sup> sol / f
- cable entries via knockouts, order ASS separately (see cable entry systems LES)
- cable junction box for encapsulating
- for ground installation without live loads or in risk of condensation formation and ingress of liquids
- installation under water without chemical additives up to a depth of 1 meter possible in the long term
- usable for heating cable / heating tape up to max. 70 °C surface temperature
- with sealing compound and sealing plug
- in case of re-installation or testing the sealing compound can be removed easily
- durability of sealing compound to processing  $\geq$  12 months at a storage temperature of 5 - 35 °C
- external brackets for wall fixing included
- enclosure volume 500 ml

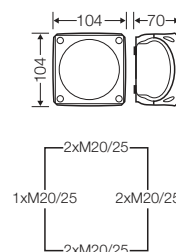

degree of protection	For totally encapsulated cable junction boxes the IP degrees of protection of enclosures according to DIN EN 60529 are not applicable.
rated insulation voltage	$U_i = 690$ V a.c./d.c.
current carrying capacity	32 A
tightening torque for terminal	0.7 Nm
material	PC-GFS (polycarbonate)



**WP 0604 B**

**1.5-4 mm<sup>2</sup>, Cu 3~**

- with terminals
- 5-pole per pole 8 x 1,5 mm<sup>2</sup> sol / f, 6 x 2,5 mm<sup>2</sup> sol / f, 4 x 4 mm<sup>2</sup> sol / f, 2 x 6 mm<sup>2</sup> sol / f
- cable entries via knockouts, order ASS separately (see cable entry systems LES)
- cable junction box for encapsulating
- for ground installation without live loads or in risk of condensation formation and ingress of liquids
- installation under water without chemical additives up to a depth of 1 meter possible in the long term
- usable for heating cable / heating tape up to max. 70 °C surface temperature
- with sealing compound and sealing plug
- in case of re-installation or testing the sealing compound can be removed easily
- durability of sealing compound to processing  $\geq$  12 months at a storage temperature of 5 - 35 °C
- external brackets for wall fixing included
- enclosure volume 850 ml

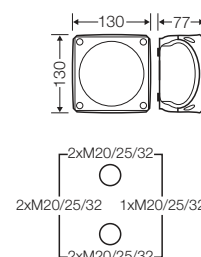

degree of protection	For totally encapsulated cable junction boxes the IP degrees of protection of enclosures according to DIN EN 60529 are not applicable.
rated insulation voltage	$U_i = 690$ V a.c./d.c.
current carrying capacity	32 A
tightening torque for terminal	0.7 Nm
material	PC-GFS (polycarbonate)



**WP 0606 B**

**1.5-6 mm<sup>2</sup>, Cu 3~**

- with terminals
- 5-pole per pole 6 x 1,5 mm<sup>2</sup> sol / f, 4 x 2,5 mm<sup>2</sup> sol / f, 4 x 4 mm<sup>2</sup> sol / f, 4 x 6 mm<sup>2</sup> sol / f, 2 x 10 mm<sup>2</sup> sol / f
- cable entries via knockouts, order ASS separately (see cable entry systems LES)
- cable junction box for encapsulating
- for ground installation without live loads or in risk of condensation formation and ingress of liquids
- installation under water without chemical additives up to a depth of 1 meter possible in the long term
- usable for heating cable / heating tape up to max. 70 °C surface temperature
- with sealing compound and sealing plug
- in case of re-installation or testing the sealing compound can be removed easily
- durability of sealing compound to processing ≥ 12 months at a storage temperature of 5 - 35 °C
- external brackets for wall fixing included
- enclosure volume 850 ml

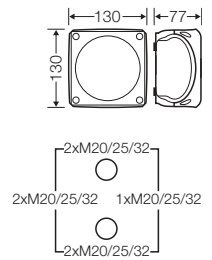

degree of protection	For totally encapsulated cable junction boxes the IP degrees of protection of enclosures according to DIN EN 60529 are not applicable.
rated insulation voltage	U <sub>i</sub> = 690 V a.c./d.c.
current carrying capacity	40 A
tightening torque for terminal	1.5 Nm
material	PC-GFS (polycarbonate)



**WP 1006 B**

**2.5-6 mm<sup>2</sup>, Cu 3~**

- with terminals
- 5-pole per pole 6 x 1,5 mm<sup>2</sup> sol / f, 4 x 2,5 mm<sup>2</sup> sol / f, 4 x 4 mm<sup>2</sup> sol / f, 4 x 6 mm<sup>2</sup> sol / f, 2 x 10 mm<sup>2</sup> sol / f
- cable entries via knockouts, order ASS separately (see cable entry systems LES)
- cable junction box for encapsulating
- for ground installation without live loads or in risk of condensation formation and ingress of liquids
- installation under water without chemical additives up to a depth of 1 meter possible in the long term
- usable for heating cable / heating tape up to max. 70 °C surface temperature
- with sealing compound and sealing plug
- in case of re-installation or testing the sealing compound can be removed easily
- durability of sealing compound to processing ≥ 12 months at a storage temperature of 5 - 35 °C
- external brackets for wall fixing included
- enclosure volume 1200 ml

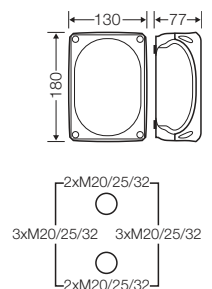

degree of protection	For totally encapsulated cable junction boxes the IP degrees of protection of enclosures according to DIN EN 60529 are not applicable.
rated insulation voltage	U <sub>i</sub> = 690 V a.c./d.c.
current carrying capacity	40 A
tightening torque for terminal	1.5 Nm
material	PC-GFS (polycarbonate)

**DK Cable junction boxes**  
**"Waterproof", for encapsulating**



**WP 1010 B**  
**4-10 mm<sup>2</sup>, Cu 3~**

- with terminals
- 5-pole per pole 6 x 2.5 mm<sup>2</sup> sol, 4 x 4 mm<sup>2</sup> sol, 4 x 6 mm<sup>2</sup> sol, 4 x 10 mm<sup>2</sup> sol, 2 x 16 mm<sup>2</sup> s
- cable entries via knockouts, order ASS separately (see cable entry systems LES)
- cable junction box for encapsulating
- for ground installation without live loads or in risk of condensation formation and ingress of liquids
- installation under water without chemical additives up to a depth of 1 meter possible in the long term
- usable for heating cable / heating tape up to max. 70 °C surface temperature
- with sealing compound and sealing plug
- in case of re-installation or testing the sealing compound can be removed easily
- durability of sealing compound to processing ≥ 12 months at a storage temperature of 5 - 35 °C
- external brackets for wall fixing included
- enclosure volume 1200 ml

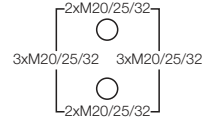
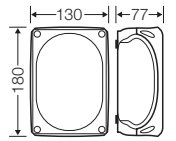

degree of protection	For totally encapsulated cable junction boxes the IP degrees of protection of enclosures according to DIN EN 60529 are not applicable.
rated insulation voltage	U <sub>i</sub> = 690 V a.c./d.c.
current carrying capacity	63 A
tightening torque for terminal	2.0 Nm
material	PC-GFS (polycarbonate)



**GH 0350**

**Set sealing compound, 350 ml**

- as spares
- sealing compound for refilling after changes or repairs
- durability of sealing compound to processing  $\geq$  12 months at a storage temperature of 5 - 35 °C



**GH 0500**

**Set sealing compound, 500 ml**

- as spares
- sealing compound for refilling after changes or repairs
- durability of sealing compound to processing  $\geq$  12 months at a storage temperature of 5 - 35 °C



**GH 0850**

**Set sealing compound, 850 ml**

- as spares
- sealing compound for refilling after changes or repairs
- durability of sealing compound to processing  $\geq$  12 months at a storage temperature of 5 - 35 °C



**GH 1200**

**Set sealing compound, 1200 ml**

- as spares
- sealing compound for refilling after changes or repairs
- durability of sealing compound to processing  $\geq$  12 months at a storage temperature of 5 - 35 °C

# Safety in the event of a fire

## Cable junction boxes from Hensel are tested for insulation integrity PH120 and intrinsic fire resistance in electrical cable systems E30/E60/E90

Especially in buildings with public traffic as department stores, airports, hospitals, etc. and other public places security is top priority. The emergency power supply in accordance with regional building regulations is generally required. In the event of fire, the functional integrity of the emergency power supply must be guaranteed for a specific period of time. This ensures that electric devices, such as emergency lighting, lifts, smoke extractors, alarms, etc. remain operational for 30, 60 or 90 minutes and that people can leave the building and rescue services can work in case of fire. In addition to these requirements electrical installation systems must fulfill especially the electrical parameters with all components.

**Generally two, but different standards and testing procedures have been established.**



## Insulation integrity PH120

Testing for resistance to fire of unprotected cable lines (cables with cable junction boxes) for use in emergency circuits. This test method considers single tested products regardless of their usage.

This test determines the period for which a mechanically unloaded cable maintains a minimum insulation integrity under fire exposure.

The test is passed, if after a test period of 120 minutes the current still flows and no short circuit or cable break can be detected.

The tested product achieves PH120 Classification.

Testing for insulation integrity is a hardness test, which only high quality materials can pass.

**Complete cable installations are not subject of this test.**

Hensel products comply with the PH120 Classification of standard BS EN 50200. Local requirements must be considered additionally. E.g. British Standard BS 5839-1:2013 places additional demands to enhance the fire-resisting level.

Testing for insulation integrity PH120:  
BS EN 50200 (> 842 °C)

Cable junction boxes with connected cables after testing



DIN 4102-12 Intrinsic fire resistance for	Classifica- tion
30 minutes	E30
60 minutes	E60
90 minutes	E90

## Intrinsic fire resistance E30/E60/E90 places higher demands

**In contrast to insulation integrity, the testing of intrinsic fire resistance accesses not just a single test product, but the cable system as a whole including all components.**

The German standard DIN 4102-12 sets the requirements on a complete cable system to achieve the functional integrity in the event of fire.

The classifications E30, E60, E90 indicate the period for which a complete cable system ensures functional integrity so that emergency power supply remains operational in case of fire, for example E90 is 90 minutes.

**The test approves a cable system as a whole under real-life conditions including all components as support systems, ca-**

**ble junction boxes and mounting device.**

Testing of functional integrity sets extreme but realistic demands on a complete cable system in combination with all installed components.

Therefore this method of test allows meaningful conclusions to be drawn on the realistic behaviour in the event of fire (full intrinsic fire resistance).

Testing on functional integrity E30/E60/E90 of cable systems in the event of fire:

DIN 4102-12 (E30-E90) German Standard

# Reliable power supply - even in the event of fire!



## Planning process for intrinsic fire resistance and insulation integrity

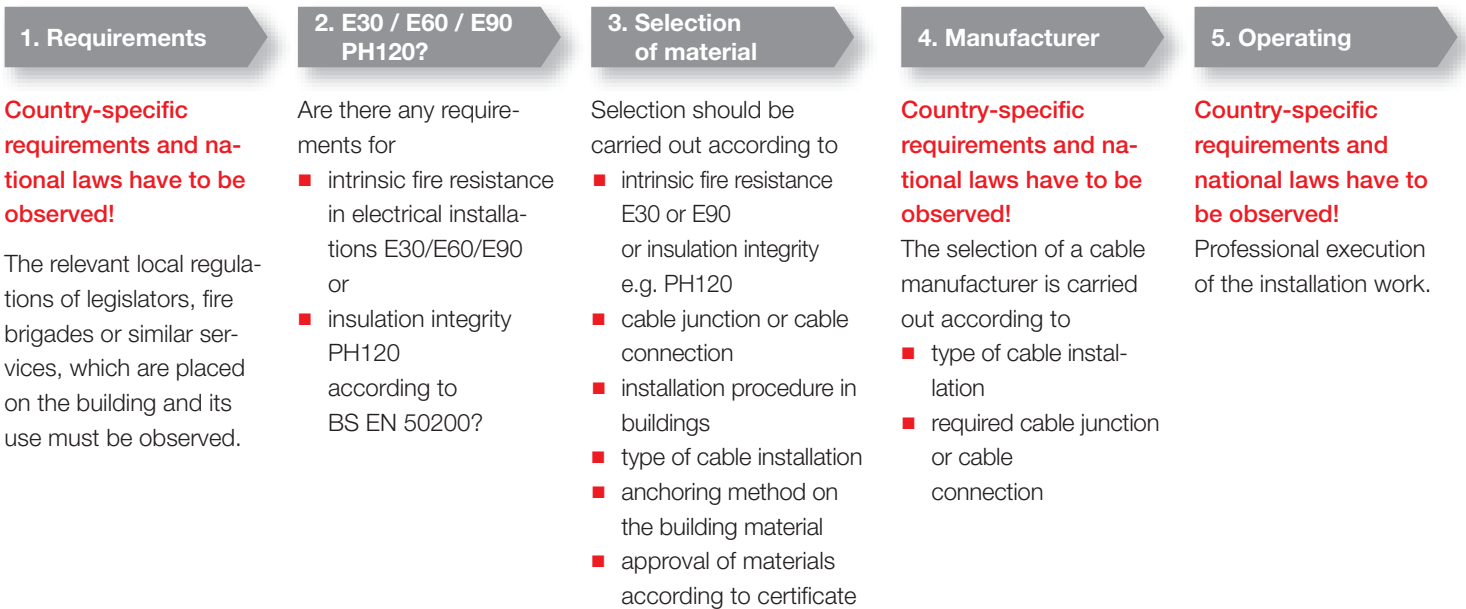



### DK Cable junction boxes

**Approved for intrinsic fire resistance and insulation integrity with included grommets**

- Intrinsic fire resistance in accordance with DIN 4102 Part 12 (German standard) in combination with function-retaining cables
- Insulation integrity PH120 in accordance with BS EN 50200 in combination with insulation retaining cables
- Screw anchors, high-temperature-resistant ceramic terminal E30 up to E90 and cable entries included as standard
- Multi-level knockouts for cable glands in different sizes
- Closes quickly by a quarter turn - locked position well visible (open - locked)
- Material: PC-GFS polycarbonate
- Colour: orange, RAL 2003
- Glow wire test in accordance with IEC 60695-2-11: 960 °C, flame-retardant, self-extinguishing
- Resistance to impact: IK 09 (10 Joule)
- Degree of protection: IP 65/66

**DK Cable junction boxes**

Approved for intrinsic fire resistance and insulation integrity  
With included grommets

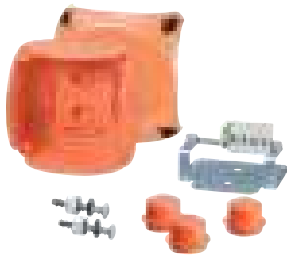

**FK 0402**

**Cable junction box 1.5 mm<sup>2</sup>, Cu**  
**Connection box 1.5-2.5 mm<sup>2</sup>, Cu**



- 5-pole per pole 4 x 1.5 mm<sup>2</sup> sol and 2 x 2.5 mm<sup>2</sup> sol
- connecting terminal made from ceramic with resistance to high temperatures
- included cable entry: 3 EDKF 25, sealing range: Ø 9-17 mm, IP 65
- IP 66 using AKMF cable glands, please order separately
- intrinsic fire resistance in accordance with DIN 4102 Part 12 (German standard) in combination with function-retaining cables
- tested with the cable manufacturer Dätwyler and Eupen for the intrinsic fire resistance E30 up to E90, see test certificate no.: P-MPA-E-15-018 valid till August 05, 2021, download available from [www.hensel-electric.de](http://www.hensel-electric.de) > type - documents
- Tested for insulation integrity in accordance with BS EN 50200 in connection with insulation retaining cables, see test certificate, download available from [www.hensel-electric.de](http://www.hensel-electric.de) > type - documents
- screw anchors enclosed can be used for concrete C20/25, limestone blocks KSV 12, building bricks MZ 12 and clinker bricks KS 12
- for normal environment and protected outdoor

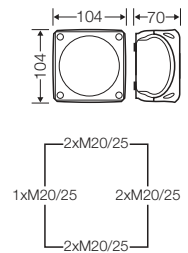

rated insulation voltage	$U_i = 400 \text{ V a.c./d.c.}$
current carrying capacity	24 A
tightening torque for terminal	0.5 Nm
material	PC-GFS (polycarbonate)



**FK 0404**

**Cable junction box 1.5-2.5 mm<sup>2</sup>, Cu**  
**Connection box 1.5-4 mm<sup>2</sup>, Cu**



- 5-pole per pole 8 x 1.5 mm<sup>2</sup> sol, 4 x 2.5 mm<sup>2</sup> sol, 2 x 4 mm<sup>2</sup> sol
- connecting terminal made from ceramic with resistance to high temperatures
- included cable entry: 3 EDKF 25, sealing range: Ø 9-17 mm, IP 65
- IP 66 using AKMF cable glands, please order separately
- intrinsic fire resistance in accordance with DIN 4102 Part 12 (German standard) in combination with function-retaining cables
- tested with the cable manufacturer Dätwyler and Eupen for the intrinsic fire resistance E30 up to E90, see test certificate no.: P-MPA-E-15-018 valid till August 05, 2021, download available from [www.hensel-electric.de](http://www.hensel-electric.de) > type - documents
- Tested for insulation integrity in accordance with BS EN 50200 in connection with insulation retaining cables, see test certificate, download available from [www.hensel-electric.de](http://www.hensel-electric.de) > type - documents
- screw anchors enclosed can be used for concrete C20/25, limestone blocks KSV 12, building bricks MZ 12 and clinker bricks KS 12
- for normal environment and protected outdoor

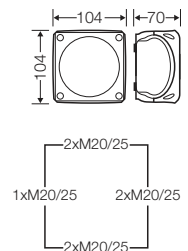

rated insulation voltage	$U_i = 400 \text{ V a.c./d.c.}$
current carrying capacity	32 A
tightening torque for terminal	1,2 Nm
material	PC-GFS (polycarbonate)

**DK Cable junction boxes**

Approved for intrinsic fire resistance and insulation integrity  
With included grommets



**FK 0604**

**Cable junction box 1.5-2.5 mm<sup>2</sup>, Cu**  
**Connection box 1.5-6 mm<sup>2</sup>, Cu**

- 5-pole per pole 8 x 1.5 mm<sup>2</sup> sol, 4 x 2.5 mm<sup>2</sup> sol, 2 x 4 mm<sup>2</sup> sol, 2 x 6 mm<sup>2</sup> sol
- connecting terminal made from ceramic with resistance to high temperatures
- included cable entry: 3 EDKF 32, sealing range: 8-23 mm, IP 65
- IP 66 using AKMF cable glands, please order separately
- intrinsic fire resistance in accordance with DIN 4102 Part 12 (German standard) in combination with function-retaining cables
- tested with the cable manufacturer Dätwyler and Eupen for the intrinsic fire resistance E30 up to E90, see test certificate no.: P-MPA-E-15-018 valid till August 05, 2021, download available from [www.hensel-electric.de](http://www.hensel-electric.de) > type - documents
- Tested for insulation integrity in accordance with BS EN 50200 in connection with insulation retaining cables, see test certificate, download available from [www.hensel-electric.de](http://www.hensel-electric.de) > type - documents
- screw anchors enclosed can be used for concrete C20/25, limestone blocks KSV 12, building bricks MZ 12 and clinker bricks KS 12
- for normal environment and protected outdoor

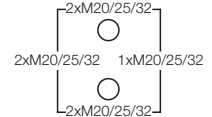
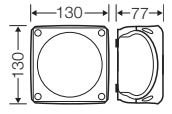

rated insulation voltage	U <sub>i</sub> = 400 V a.c./d.c.
current carrying capacity	41 A
tightening torque for terminal	1,2 Nm
material	PC-GFS (polycarbonate)



**FK 0606**

**Cable junction box 1.5-6 mm<sup>2</sup>, Cu**  
**Connection box 1.5-6 mm<sup>2</sup>, Cu**

- 5-pole per pole 12 x 1.5 mm<sup>2</sup> sol, 8 x 2.5 mm<sup>2</sup> sol, 6 x 4 mm<sup>2</sup> sol, 4 x 6 mm<sup>2</sup> sol
- connecting terminal made from ceramic with resistance to high temperatures
- included cable entry: 3 EDKF 32, sealing range: 8-23 mm, IP 65
- IP 66 using AKMF cable glands, please order separately
- intrinsic fire resistance in accordance with DIN 4102 Part 12 (German standard) in combination with function-retaining cables
- tested with the cable manufacturer Dätwyler and Eupen for the intrinsic fire resistance E30 up to E90, see test certificate no.: P-MPA-E-15-018 valid till August 05, 2021, download available from [www.hensel-electric.de](http://www.hensel-electric.de) > type - documents
- Tested for insulation integrity in accordance with BS EN 50200 in connection with insulation retaining cables, see test certificate, download available from [www.hensel-electric.de](http://www.hensel-electric.de) > type - documents
- screw anchors enclosed can be used for concrete C20/25, limestone blocks KSV 12, building bricks MZ 12 and clinker bricks KS 12
- for normal environment and protected outdoor

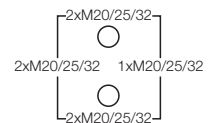
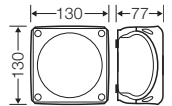

rated insulation voltage	U <sub>i</sub> = 400 V a.c./d.c.
current carrying capacity	41 A
tightening torque for terminal	2.0 Nm
material	PC-GFS (polycarbonate)

**DK Cable junction boxes**  
**Approved for intrinsic fire resistance and insulation integrity**  
**With included grommets**



**FK 1606**

**Cable junction box 1.5-6 mm<sup>2</sup>, Cu**  
**Connection box 1.5-6 mm<sup>2</sup>, Cu**



- 5 terminals per pole 12 x 1,5 mm<sup>2</sup> sol, 8 x 2,5 mm<sup>2</sup> sol, 6 x 4 mm<sup>2</sup> sol, 4 x 6 mm<sup>2</sup> sol
- terminal for 4 x 1,5 mm<sup>2</sup> sol or 2 x 2,5 mm<sup>2</sup> sol and PE terminal
- connecting terminal made from ceramic with resistance to high temperatures
- included cable entry: 3 EDKF 32, sealing range: 8-23 mm, IP 65
- IP 66 using AKMF cable glands, please order separately
- intrinsic fire resistance in accordance with DIN 4102 Part 12 (German standard) in combination with function-retaining cables
- tested with the cable manufacturer Dätwyler and Eupen for the intrinsic fire resistance E30 up to E90, see test certificate no.: P-MPA-E-15-018 valid till August 05, 2021, download available from [www.hensel-electric.de](http://www.hensel-electric.de) > type - documents
- Tested for insulation integrity in accordance with BS EN 50200 in connection with insulation retaining cables, see test certificate, download available from [www.hensel-electric.de](http://www.hensel-electric.de) > type - documents
- screw anchors enclosed can be used for concrete C20/25, limestone blocks KSV 12, building bricks MZ 12 and clinker bricks KS 12
- for normal environment and protected outdoor

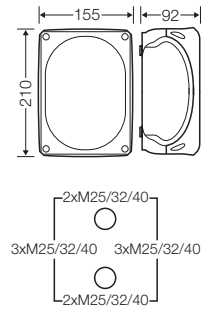

rated insulation voltage	U <sub>i</sub> = 400 V a.c./d.c.
current carrying capacity	41 A
tightening torque for terminal	2.0 Nm 0.5 Nm
material	PC-GFS (polycarbonate)



**FK 1608**

**Cable junction box 1.5 mm<sup>2</sup>, Cu**  
**Connection box 1.5-2.5 mm<sup>2</sup>, Cu**



- 10-pole per pole 4 x 1.5 mm<sup>2</sup> sol and 2 x 2.5 mm<sup>2</sup> sol
- connecting terminal made from ceramic with resistance to high temperatures
- included cable entry: 4 EDKF 25, sealing range: Ø 9-17 mm, IP 65
- IP 66 using AKMF cable glands, please order separately
- intrinsic fire resistance in accordance with DIN 4102 Part 12 (German standard) in combination with function-retaining cables
- tested with the cable manufacturer Dätwyler and Eupen for the intrinsic fire resistance E30 up to E90, see test certificate no.: P-MPA-E-15-018 valid till August 05, 2021, download available from [www.hensel-electric.de](http://www.hensel-electric.de) > type - documents
- Tested for insulation integrity in accordance with BS EN 50200 in connection with insulation retaining cables, see test certificate, download available from [www.hensel-electric.de](http://www.hensel-electric.de) > type - documents
- screw anchors enclosed can be used for concrete C20/25, limestone blocks KSV 12, building bricks MZ 12 and clinker bricks KS 12
- for normal environment and protected outdoor

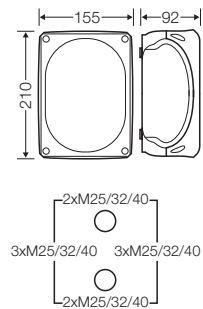

rated insulation voltage	U <sub>i</sub> = 400 V a.c./d.c.
current carrying capacity	24 A
tightening torque for terminal	0.5 Nm
material	PC-GFS (polycarbonate)

**DK Cable junction boxes**

Approved for intrinsic fire resistance and insulation integrity  
With included grommets



**FK 1610**

**Cable junction box 1.5-2.5 mm<sup>2</sup>, Cu**  
**Connection box 1.5-10 mm<sup>2</sup>, Cu**

- 5-pole per pole 8 x 1.5 mm<sup>2</sup> sol, 4 x 2.5 mm<sup>2</sup> sol, 2 x 4 mm<sup>2</sup> sol, 2 x 6 mm<sup>2</sup> sol, 2 x 10 mm<sup>2</sup> sol
- connecting terminal made from ceramic with resistance to high temperatures
- included cable entry: 3 EDKF 32, sealing range: 8-23 mm, IP 65
- IP 66 using AKMF cable glands, please order separately
- intrinsic fire resistance in accordance with DIN 4102 Part 12 (German standard) in combination with function-retaining cables
- tested with the cable manufacturer Dätwyler and Eupen for the intrinsic fire resistance E30 up to E90, see test certificate no.: P-MPA-E-15-018 valid till August 05, 2021, download available from [www.hensel-electric.de](http://www.hensel-electric.de) > type - documents
- Tested for insulation integrity in accordance with BS EN 50200 in connection with insulation retaining cables, see test certificate, download available from [www.hensel-electric.de](http://www.hensel-electric.de) > type - documents
- screw anchors enclosed can be used for concrete C20/25, limestone blocks KSV 12, building bricks MZ 12 and clinker bricks KS 12
- for normal environment and protected outdoor

PH120	E30 E60 E90	IP 65/66
-------	-------------------	-------------

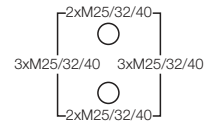
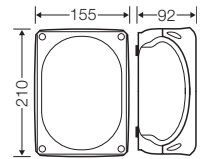

rated insulation voltage	U <sub>i</sub> = 400 V a.c./d.c.
current carrying capacity	57 A
tightening torque for terminal material	1,2 Nm PC-GFS (polycarbonate)



**FK 1616**

**Cable junction box 1.5-6 mm<sup>2</sup>, Cu**  
**Connection box 1.5-16 mm<sup>2</sup>, Cu**

- 5-pole per pole 12 x 1.5 mm<sup>2</sup> sol, 8 x 2.5 mm<sup>2</sup> sol, 6 x 4 mm<sup>2</sup> sol, 4 x 6 mm<sup>2</sup> sol, 2 x 10 mm<sup>2</sup> sol, 2 x 16 mm<sup>2</sup> r
- connecting terminal made from ceramic with resistance to high temperatures
- included cable entry: 3 EDKF 40, sealing range: 11-30 mm, IP 65
- IP 66 using AKMF cable glands, please order separately
- intrinsic fire resistance in accordance with DIN 4102 Part 12 (German standard) in combination with function-retaining cables
- tested with the cable manufacturer Dätwyler and Eupen for the intrinsic fire resistance E30 up to E90, see test certificate no.: P-MPA-E-15-018 valid till August 05, 2021, download available from [www.hensel-electric.de](http://www.hensel-electric.de) > type - documents
- Tested for insulation integrity in accordance with BS EN 50200 in connection with insulation retaining cables, see test certificate, download available from [www.hensel-electric.de](http://www.hensel-electric.de) > type - documents
- screw anchors enclosed can be used for concrete C20/25, limestone blocks KSV 12, building bricks MZ 12 and clinker bricks KS 12
- for normal environment and protected outdoor

PH120	E30 E60 E90	IP 65/66
-------	-------------------	-------------

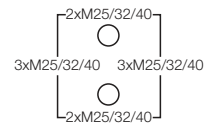
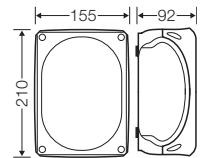

rated insulation voltage	U <sub>i</sub> = 400 V a.c./d.c.
current carrying capacity	76 A
tightening torque for terminal material	2.0 Nm PC-GFS (polycarbonate)

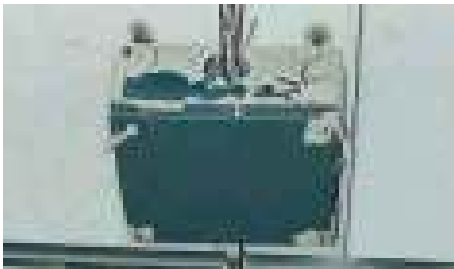

### DK Cable junction boxes

**Approved for intrinsic fire resistance and insulation integrity**  
**Cable entry via mounted grommets**

- Intrinsic fire resistance in accordance with DIN 4102 Part 12 (German standard) in combination with function-retaining cables
- Insulation integrity PH120 in accordance with BS EN 50200 in combination with insulation retaining cables
- Protection against accidental contact is ensured by the enclosure
- External brackets for fastening
- Cable junction box for tunnel application for large conductor cross-sections up to 50 mm<sup>2</sup>
- Communication junction box E30 for the installation of connecting device for telecommunications
- Material: sheet steel, powder-coated
- Colour: orange, RAL 2003
- Resistance to impact: IK 10 (20 Joule)
- Degree of protection: IP 66
- Low fire load

**DK Cable junction boxes**

Approved for intrinsic fire resistance and insulation integrity  
Cable entry via mounted grommets



**FK 9025**

**Cable junction box Ø 0.8 mm / 0.5-1.5 mm<sup>2</sup>, Cu**  
**Connection box Ø 0.8 mm / 0.5-4 mm<sup>2</sup>, Cu**

- 5-pole per pole 4 x Ø 0.8 mm / 0.5 mm<sup>2</sup> sol, 4 x 1.5 mm<sup>2</sup> sol, 2 x 2.5 mm<sup>2</sup> sol, 2 x 4 mm<sup>2</sup> sol
- connecting terminal made from ceramic with resistance to high temperatures
- mounted grommets 4 EDKF 32, sealing range: Ø 8-23 mm, closed
- intrinsic fire resistance in accordance with DIN 4102 Part 12 (German standard) in combination with function-retaining cables
- Tested with cable manufacturers Dätwyler, Eupen, Nexans, Studer, Pirelli and Lynenwerk for the intrinsic fire resistance E30 and E90, see test certificate no.: P-MPA-E-02-032, valid till March 20, 2018, download available from [www.hensel-electric.de](http://www.hensel-electric.de)
- Tested for insulation integrity in accordance with BS EN 50200 in connection with insulation retaining cables, see test certificate, download available from [www.hensel-electric.de](http://www.hensel-electric.de) > type - documents
- mounted using exterior wall fixings, bore hole 8.2 mm(for dowels refer to technical data)
- for normal environment and protected outdoor

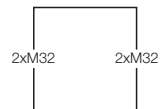
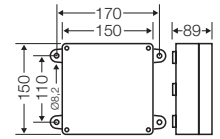

rated insulation voltage	$U_i = 400 \text{ V a.c./d.c.}$
current carrying capacity	32 A
tightening torque for terminal	0.5 Nm
material	Sheet steel, powder-coated



**FK 9105**

**Cable junction box 1.5-4 mm<sup>2</sup>, Cu**  
**Connection box 1.5-10 mm<sup>2</sup>, Cu**

- 5-pole per pole 4 x 1.5 mm<sup>2</sup> sol, 4 x 2.5 mm<sup>2</sup> sol, 4 x 4 mm<sup>2</sup> sol, 2 x 6 mm<sup>2</sup> sol, 2 x 10 mm<sup>2</sup> sol
- connecting terminal made from ceramic with resistance to high temperatures
- mounted grommets 4 EDKF 32, sealing range: Ø 8-23 mm, closed
- intrinsic fire resistance in accordance with DIN 4102 Part 12 (German standard) in combination with function-retaining cables
- Tested with cable manufacturers Dätwyler, Eupen, Nexans, Studer, Pirelli and Lynenwerk for the intrinsic fire resistance E30 and E90, see test certificate no.: P-MPA-E-02-032, valid till March 20, 2018, download available from [www.hensel-electric.de](http://www.hensel-electric.de)
- Tested for insulation integrity in accordance with BS EN 50200 in connection with insulation retaining cables, see test certificate, download available from [www.hensel-electric.de](http://www.hensel-electric.de) > type - documents
- mounted using exterior wall fixings, bore hole 8.2 mm(for dowels refer to technical data)
- for normal environment and protected outdoor

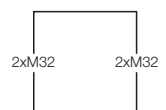
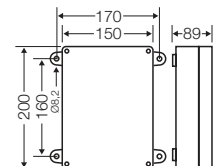

rated insulation voltage	$U_i = 400 \text{ V a.c./d.c.}$
current carrying capacity	40 A
tightening torque for terminal	1,2 Nm
material	Sheet steel, powder-coated

**DK Cable junction boxes**

Approved for intrinsic fire resistance and insulation integrity  
Cable entry via mounted grommets

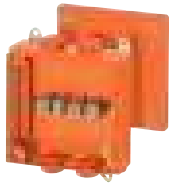

**FK 9255**

**Cable junction box 1.5-6 mm<sup>2</sup>, Cu**  
**Connection box 1.5-16 mm<sup>2</sup>, Cu**

- 5-pole per pole 4 x 1.5 mm<sup>2</sup> sol, 4 x 2.5 mm<sup>2</sup> sol, 4 x 4 mm<sup>2</sup> sol, 4 x 6 mm<sup>2</sup> sol, 2 x 10 mm<sup>2</sup> sol, 2 x 16 mm<sup>2</sup> r (remove cable protection)
- connecting terminal made from ceramic with resistance to high temperatures
- mounted grommets 4 EDKF 40, sealing range Ø 11-30 mm, closed
- intrinsic fire resistance in accordance with DIN 4102 Part 12 (German standard) in combination with function-retaining cables
- Tested with cable manufacturers Dätwyler, Eupen, Nexans, Studer, Pirelli and Lynenwerk for the intrinsic fire resistance E30 and E90, see test certificate no.: P-MPA-E-02-032, valid till March 20, 2018, download available from [www.hensel-electric.de](http://www.hensel-electric.de)
- Tested for insulation integrity in accordance with BS EN 50200 in connection with insulation retaining cables, see test certificate, download available from [www.hensel-electric.de](http://www.hensel-electric.de) > type - documents
- mounted using exterior wall fixings, bore hole 8.2 mm(for dowels refer to technical data)
- for normal environment and protected outdoor

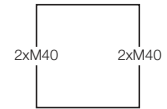
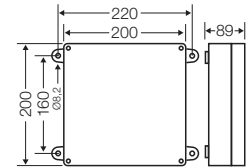

rated insulation voltage	U <sub>i</sub> = 400 V a.c./d.c.
current carrying capacity	63 A
tightening torque for terminal	2.0 Nm
material	Sheet steel, powder-coated

**DK Cable junction boxes**

Approved for intrinsic fire resistance and insulation integrity  
Cable entry via mounted grommets



**FK 6505**

**Cable junction box E90 16-35 mm<sup>2</sup>, Cu, "r"**  
**Connection box E90 16-50 mm<sup>2</sup>, Cu, "r"**

- 5-pole per pole 6 x 16 mm<sup>2</sup> r, 4 x 25 mm<sup>2</sup> r, 4 x 35 mm<sup>2</sup> r, 2 x 50 mm<sup>2</sup> r
- connecting terminal made from ceramic with resistance to high temperatures
- mounted cable entries 2 ASS 63, sealing range Ø 20-48 mm
- on the longitudinal sides each with 2 locking screws M 50
- intrinsic fire resistance in accordance with DIN 4102 Part 12 (German standard) in combination with function-retaining cables
- Tested with cable manufacturers Dätwyler, Prysmian and Eupen for the intrinsic fire resistance E90, see test certificate no.: P-1011 DMT DO, download at [www.hensel-electric.de](http://www.hensel-electric.de) > Type - Documents
- mounted using exterior wall fixings, keyhole 8 mm (dowel refer to technical data)
- for normal environment and protected outdoor

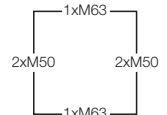
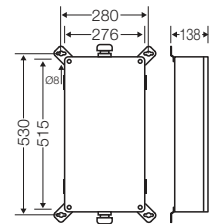

rated insulation voltage	U <sub>i</sub> = 690 V a.c./d.c.
current carrying capacity	150 A
tightening torque for terminal material	4,0 Nm
	External brackets for wall fixing: Stainless steel 1.4462, resistance class IV
	Enclosure including lid and outer screws: Stainless steel 1.4571, resistance class III powder-coated

Søknad:



For the connection of large cable cross sections up to 50 mm<sup>2</sup>



The cable junction box for tunnel application offers lot of space for wiring

**DK Cable junction boxes**

Approved for intrinsic fire resistance and insulation integrity  
Cable entry via mounted grommets



**FK 9259**

**Cable junction box 1.5-10 mm<sup>2</sup>, Cu**

- cable junction box with fused outgoing unit
- D 01 neozed fuse base
- 5-pole terminal with 2 connecting terminals, 2 junction terminals and 2 PE terminals, each 1.5-10 mm<sup>2</sup> sol
- terminal block made from ceramic with resistance to high temperatures
- mounted grommets 4 EDKF 40, sealing range Ø 11-30 mm, closed
- intrinsic fire resistance E 30 in accordance with DIN 4102 part 12
- the use of this equipment requires the approval from the building and regulatory authorities for the individual case
- Tested with cable manufacturers Dätwyler and Nexans for the intrinsic fire resistance E30
- mounted using exterior wall fixings, bore hole 8.2 mm(for dowels refer to technical data)
- for normal environment and protected outdoor

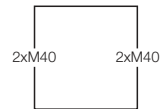
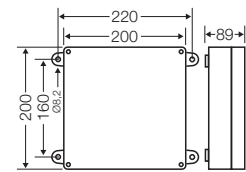

rated insulation voltage	U <sub>i</sub> = 400 V a.c.
current carrying capacity	40 A
tightening torque for terminal material	2,0 -2,4 Nm
	Sheet steel, powder-coated

**FK 9259, with fused outgoing circuit**

Can be used in emergency lighting in installations that cover a large area (e.g. tunnels).

The use of a fused branch circuit makes it possible to supply a group of emergency luminaires with one supply lead.

If one or several emergency luminaires are damaged during a fire, the back-up fuse is tripped and ensures that the power supply of the common supply lead is maintained.

**The use of this equipment requires approval from the planning department and building control office for individual cases.**

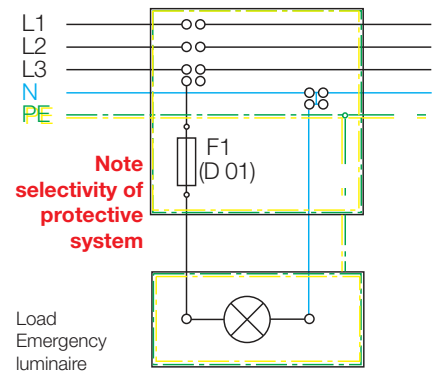

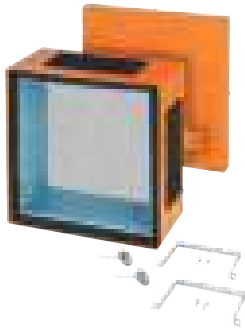

**FK 5000**

**Communication junction box E30 for the installation of connecting device for telecommunications**



- without terminals
- with mounting brackets for the installation of connecting device for telecommunications
- intrinsic fire resistance in accordance with DIN 4102 Part 12 (German standard) in combination with function-retaining cables
- cable entry via integrated elastic membranes
- cable entry on 4 sides each 1 x up to Ø 36 mm and 4 x up to Ø 14 mm
- the attached screw anchors must be used for concrete ≥ C20/25, B25 up to ≤ C50/60, B55
- the use of this equipment requires the approval from the building and regulatory authorities for the individual case
- general approval by the German building authorities DIBt: Z-86.1-37, Celsion fire protection systems, download at [www.hensel-electric.de](http://www.hensel-electric.de) > FK 5000 - documents

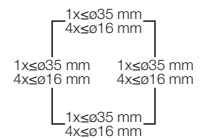
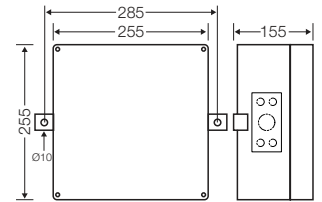

material

Sheet steel, powder-coated



**FK 5110**

**Connecting device for telecommunications screwless for 10 pairs**

- LSA connection technology, solder and screwless, no insulation removal is required
- for installation on mounting brackets in FK 5000
- suitable for a solid conductor with diameter of 0.4 up to 0.8 mm or for two identical solid conductors with diameters of 0.4 up to 0.65 mm
- outer diameter of insulation 0.7 up to 1.6 mm
- with fixing screws

rated insulation voltage	U <sub>i</sub> = 100 V a.c. U <sub>i</sub> = 125 V d.c.
current carrying capacity	Solid conductor up to Ø 0.6 mm max. 2.1 A Solid conductor Ø 0.8 mm max. 5.0 A

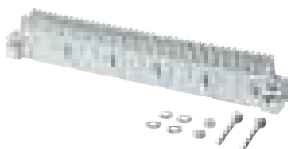

**FK 5120**

**Connecting device for telecommunications screwless for 20 pairs**

- LSA connection technology, solder and screwless, no insulation removal is required
- for installation on mounting brackets in FK 5000
- suitable for a solid conductor with diameter of 0.4 up to 0.8 mm or for two identical solid conductors with diameters of 0.4 up to 0.65 mm
- outer diameter of insulation 0.7 up to 1.6 mm
- with fixing screws

rated insulation voltage	U <sub>i</sub> = 100 V a.c. U <sub>i</sub> = 125 V d.c.
current carrying capacity	Solid conductor up to Ø 0.6 mm max. 2.1 A Solid conductor Ø 0.8 mm max. 5.0 A

**DK Cable junction boxes**  
**Approved for Intrinsic Fire Resistance**  
**Communication Box**

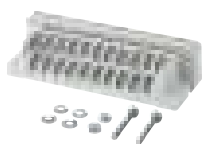

**FK 5210**

**Connecting device for telecommunications**  
**Screw-type connection for 10 pairs**

- screw/screw connection technology
- for installation on mounting brackets in FK 5000
- suitable for a solid conductor with diameter of 0.4 up to 0.8 mm or for two identical solid conductors with diameters of 0.4 up to 0.65 mm
- with fixing screws
- with labelling strips

rated insulation voltage	U <sub>i</sub> = 100 V a.c. U <sub>i</sub> = 125 V d.c.
current carrying capacity	Solid conductor up to Ø 0.6 mm max. 2.1 A Solid conductor Ø 0.8 mm max. 5.0 A

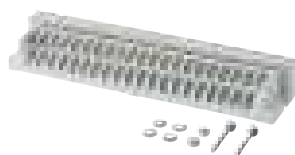

**FK 5220**

**Connecting device for telecommunications**  
**screw-type connection for 20 pairs**

- screw/screw connection technology
- for installation on mounting brackets in FK 5000
- suitable for a solid conductor with diameter of 0.4 up to 0.8 mm or for two identical solid conductors with diameters of 0.4 up to 0.65 mm
- with fixing screws
- with labelling strips

rated insulation voltage	U <sub>i</sub> = 100 V a.c. U <sub>i</sub> = 125 V d.c.
current carrying capacity	Solid conductor up to Ø 0.6 mm max. 2.1 A Solid conductor Ø 0.8 mm max. 5.0 A



**AKMF 20**

**Cable glands for knockouts M 20**

- sealing range Ø 6,5-13,5 mm
- ISO thread M 20 x 1.5
- bore-hole: Ø 20.3 mm
- wall thickness up to 3 mm
- with strain relief and locknut
- for indoor - normal environment and (or) protected outdoor installation
- ambient temperature - 25 °C to + 55 °C
- glow wire test IEC 60695-2-11: 960 °C

IP  
66



tightening torque	4.0 Nm
-------------------	--------



**AKMF 25**

**Cable glands for knockouts M 25**

- sealing range Ø 11-17 mm
- ISO thread M 25 x 1.5
- bore-hole: Ø 25.3 mm
- wall thickness up to 3 mm
- with strain relief and locknut
- for indoor - normal environment and (or) protected outdoor installation
- ambient temperature - 25 °C to + 55 °C
- glow wire test IEC 60695-2-11: 960 °C

IP  
66



tightening torque	7.5 Nm
-------------------	--------



**AKMF 32**

**Cable glands for knockouts M 32**

- sealing range Ø 15-21 mm
- ISO thread M 32 x 1.5
- bore-hole: Ø 32.3 mm
- wall thickness up to 3 mm
- with strain relief and locknut
- for indoor - normal environment and (or) protected outdoor installation
- ambient temperature - 25 °C to + 55 °C
- glow wire test IEC 60695-2-11: 960 °C

IP  
66



tightening torque	10.0 Nm
-------------------	---------



**AKMF 40**

**Cable glands for knockouts M 40**

- sealing range: Ø 19-28 mm
- ISO thread M 40 x 1.5
- bore-hole: Ø 40.3 mm
- wall thickness up to 3 mm
- with strain relief and locknut
- for indoor - normal environment and (or) protected outdoor installation
- ambient temperature - 25 °C to + 55 °C
- glow wire test IEC 60695-2-11: 960 °C

IP  
66



tightening torque	10.0 Nm
-------------------	---------

## DK Cable junction boxes

Approved for intrinsic fire resistance cable entry



### EDKF 20

#### Grommets for knockouts M 20

- sealing range: Ø 6-13 mm
- bore-hole: Ø 20.5 mm
- wall thickness 1.5-3.5 mm
- for indoor - normal environment and (or) protected outdoor installation
- ambient temperature - 25 °C to + 35 °C
- glow wire test IEC 60695-2-11: 750 °C

IP  
65/66

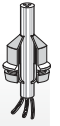

### EDKF 25

#### Grommets for knockouts M 25

- sealing range: Ø 9-17 mm
- bore-hole: Ø 25.5 mm
- wall thickness 1.5-3.5 mm
- for indoor - normal environment and (or) protected outdoor installation
- ambient temperature - 25 °C to + 35 °C
- glow wire test IEC 60695-2-11: 750 °C

IP  
65/66

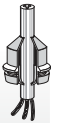

### EDKF 32

#### Grommets for knockouts M 32

- sealing range: Ø 8-23 mm
- bore-hole: Ø 32.5 mm
- wall thickness 1.5-3.5 mm
- for indoor - normal environment and (or) protected outdoor installation
- ambient temperature - 25 °C to + 35 °C
- glow wire test IEC 60695-2-11: 750 °C

IP  
65/66

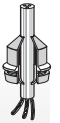

### EDKF 40

#### Grommets for knockouts M 40

- sealing range: Ø 11-30 mm
- bore-hole: Ø 40.5 mm
- wall thickness 1.5-3.5 mm
- for indoor - normal environment and (or) protected outdoor installation
- ambient temperature - 25 °C to + 35 °C
- glow wire test IEC 60695-2-11: 750 °C

IP  
65/66

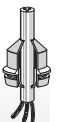



### DK Cable junction boxes

for normal environment and protected outdoor

For cable trunking and conduit installation

Cable entry via knockouts

- Simply cut out cable trunking wall to the required width.
- Cables can be inserted from the front
- No threading of cables necessary!
- Supplied accessory: removable grommets DPS 02 (IP 54)
- The perfect installation solution for cable trunking!
- Gap closed: Removable trunking adapters for connection of cable trunkings to junction boxes.
- Labelling system: label template in the Internet at [www.hensel-electric.de](http://www.hensel-electric.de) - downloads
- Stainless steel cover screws with quick fastening metric thread. Reducing cover fixing time.
- Material: polystyrene
- Burning behaviour: glow wire test in accordance with IEC 60695-2-11: 750 °C, flame-retardant, self-extinguishing
- Colour: grey, RAL 7035

**DK Cable junction boxes**  
**Cable entry via knockouts**  
**For cable trunking and conduit installation**



**DP 9025**  
**1.5-2.5 mm<sup>2</sup>, Cu 3~**

- with terminals
- 5-pole per pole 6 x 1.5 mm<sup>2</sup> sol, 4 x 2.5 mm<sup>2</sup> sol, 3 x 4 mm<sup>2</sup> sol
- for cable trunking and conduit installation
- included cable entry: 4 DPS 02, sealing range Ø 10-13,5 mm
- for normal environment and protected outdoor

rated insulation voltage	U <sub>i</sub> = 690 V a.c./d.c.
tightening torque for terminal	1,2 Nm
material	PS (Polystyrene)

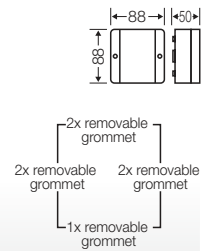

**DP 9221**  
**1.5-2.5 mm<sup>2</sup>, Cu 3~**

- with terminals
- 5-pole per pole 6 x 1.5 mm<sup>2</sup> sol, 4 x 2.5 mm<sup>2</sup> sol, 3 x 4 mm<sup>2</sup> sol
- for cable trunking and conduit installation
- included cable entry: 7 DPS 02, sealing range Ø 10-13,5 mm
- for normal environment and protected outdoor

rated insulation voltage	U <sub>i</sub> = 690 V a.c./d.c.
tightening torque for terminal	1,2 Nm
material	PS (Polystyrene)

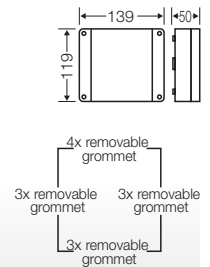

**DP 9222**  
**1.5-2.5 mm<sup>2</sup>, Cu 3~**

- with 2 terminals
- 5-pole per pole 6 x 1.5 mm<sup>2</sup> sol, 4 x 2.5 mm<sup>2</sup> sol, 3 x 4 mm<sup>2</sup> sol
- for cable trunking and conduit installation
- included cable entry: 7 DPS 02, sealing range Ø 10-13,5 mm
- for normal environment and protected outdoor

rated insulation voltage	U <sub>i</sub> = 690 V a.c./d.c.
tightening torque for terminal	1,2 Nm
material	PS (Polystyrene)

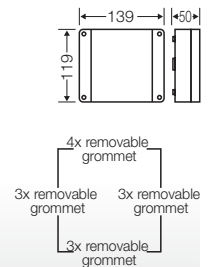

**DPC 9225**  
**1.5-2.5 mm<sup>2</sup>, Cu 3~**

- FIXCONNECT® plug-in terminal technology
- 5-pole per pole 4 x 1 x 1.5-2.5 mm<sup>2</sup> sol/f, terminal technology, see annex DK Cable junction boxes
- for cable trunking and conduit installation
- included cable entry: 4 DPS 02, sealing range Ø 10-13,5 mm
- for normal environment and protected outdoor

rated insulation voltage	U <sub>i</sub> = 690 V a.c./d.c.
current carrying capacity	32 A
material	PS (Polystyrene)

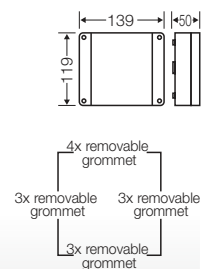

**DK Cable junction boxes**  
**Cable entry via knockouts**  
**For cable trunking and conduit installation**



**DP 9020**

- without terminals
- for cable trunking and conduit installation
- included cable entry: 4 DPS 02, sealing range Ø 10-13,5 mm
- for normal environment and protected outdoor

material	PS (Polystyrene)
----------	------------------

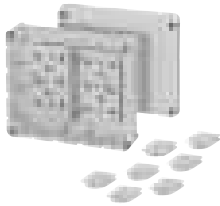
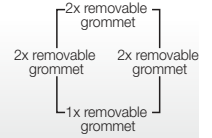
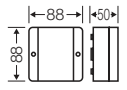

**DP 9220**

- without terminals
- for cable trunking and conduit installation
- included cable entry: 7 DPS 02, sealing range Ø 10-13,5 mm
- for normal environment and protected outdoor

material	PS (Polystyrene)
----------	------------------

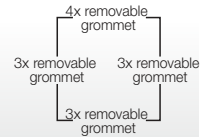
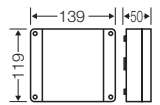

## DK Cable junction boxes

Cable entry via knockouts  
For cable trunking and conduit installation



### DPS 02

#### Removable grommet

IP  
54

- degree of protection: IP 54 sealing range Ø 10-13.5 mm
- for retrofitting
- for cable junction boxes DP 9020, DP 9220, DP 9025, DP 9221, DP 9222, DP 9026, DPC 9225



### ERA 20

#### Removable conduit adapter

IP  
54

- degree of protection: IP 54 sealing range Ø 10-13.5 mm
- for wiring conduits M 20
- for cable junction boxes DP 9020, DP 9220, DP 9025, DP 9221, DP 9222, DP 9026, DPC 9225



### EKA 20

#### Removable trunking adapter

IP  
54

- degree of protection: IP 54 sealing range Ø 10-13.5 mm
- for mini trunking up to 20 x 20 mm
- for cable junction boxes DP 9020, DP 9220, DP 9025, DP 9221, DP 9222, DP 9026, DPC 9225



### DK Cable junction boxes

for normal environment and protected outdoor

Cable entry via elastic membranes in the box walls

- No punching tool required - insert the conductor and it's done.
- Box wall with three cable entries
- Grommet supplied for sealing membranes in case of modifications.
- Labelling system: label template in the Internet at [www.hensel-electric.de](http://www.hensel-electric.de) - downloads
- Stainless steel cover screws with quick fastening metric thread. Reducing cover fixing time.
- Material: polystyrene
- Burning behaviour: glow wire test in accordance with IEC 60695-2-11: 750 °C, flame-retardant, self-extinguishing
- Colour: grey RAL 7035 or white RAL 9016

## DK Cable junction boxes

### Cable entry via elastic membranes

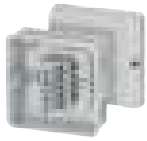

### DE 9325

#### 1.5-2.5 mm<sup>2</sup>, Cu 3~

- with terminals
- 5-pole per pole 6 x 1.5 mm<sup>2</sup> sol, 4 x 2.5 mm<sup>2</sup> sol, 3 x 4 mm<sup>2</sup> sol
- 10 elastic membranes, closed cable entries, sealing range Ø 6.5-16 mm
- colour: grey, RAL 7035
- for normal environment and protected outdoor

rated insulation voltage	$U_i = 690 \text{ V a.c./d.c.}$
tightening torque for terminal	1,2 Nm
material	PS (Polystyrene)

IP  
55

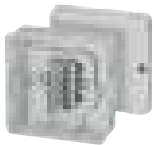
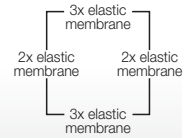
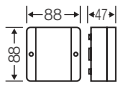

### DE 9345

#### 1.5-4 mm<sup>2</sup>, Cu 3~

- with terminals
- 5-pole per pole 6 x 1.5 mm<sup>2</sup> sol, 4 x 2.5 mm<sup>2</sup> sol, 3 x 4 mm<sup>2</sup> sol, 2 x 6 mm<sup>2</sup> sol
- 10 elastic membranes, closed cable entries, sealing range Ø 6.5-18 mm
- colour: grey, RAL 7035
- for normal environment and protected outdoor

rated insulation voltage	$U_i = 690 \text{ V a.c./d.c.}$
tightening torque for terminal	1,2 Nm
material	PS (Polystyrene)

IP  
55

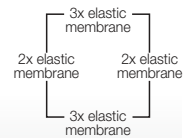
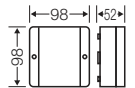

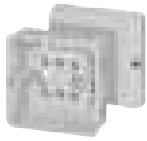

**DE 9320**

- without terminals
- 10 elastic membranes, closed cable entries, sealing range Ø 6.5-16 mm
- colour: grey, RAL 7035
- for normal environment and protected outdoor

material PS (Polystyrene)

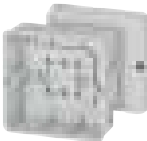
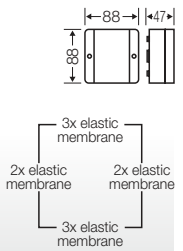

**DE 9340**

- without terminals
- 10 elastic membranes, closed cable entries, sealing range Ø 6.5-18 mm
- colour: grey, RAL 7035
- for normal environment and protected outdoor

material PS (Polystyrene)

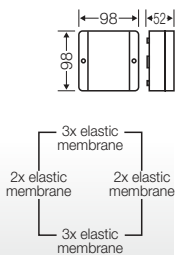

**DE 9330**

- without terminals
- 10 elastic membranes, closed cable entries, sealing range Ø 6.5-16 mm
- with cable retention (2 pc.) for cable tie up to 6.5 mm width
- colour: grey, RAL 7035
- for normal environment and protected outdoor

material PS (Polystyrene)

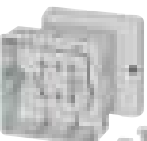
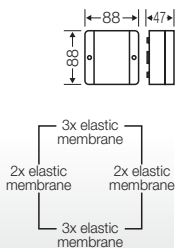

**DE 9350**

- without terminals
- 10 elastic membranes, closed cable entries, sealing range Ø 6.5-18 mm
- with cable retention (2 pc.) for cable tie up to 6.5 mm width
- colour: grey, RAL 7035
- for normal environment and protected outdoor

material PS (Polystyrene)

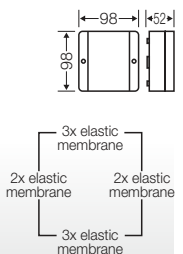

Accessories:

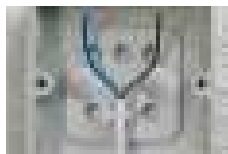

Cable retention with cable clip for fixing on the bottom

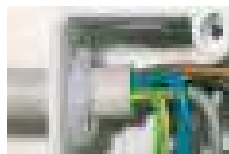

Cable retention via retention rings for cables

**DK Cable junction boxes**  
Cable entry via elastic membranes



**DE 9326**  
**1.5-2.5 mm<sup>2</sup>, Cu 3~**

- with terminals
- 5-pole per pole 6 x 1.5 mm<sup>2</sup> sol, 4 x 2.5 mm<sup>2</sup> sol, 3 x 4 mm<sup>2</sup> sol
- 10 elastic membranes, closed cable entries, sealing range Ø 6.5-16 mm
- colour: white, RAL 9016
- for normal environment and protected outdoor

rated insulation voltage	U <sub>i</sub> = 690 V a.c./d.c.
tightening torque for terminal	1,2 Nm
material	PS (Polystyrene)

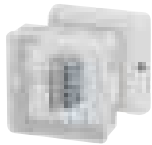
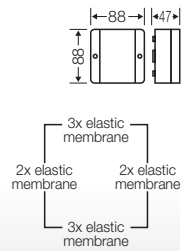

**DE 9346**  
**1.5-4 mm<sup>2</sup>, Cu 3~**

- with terminals
- 5-pole per pole 6 x 1.5 mm<sup>2</sup> sol, 4 x 2.5 mm<sup>2</sup> sol, 3 x 4 mm<sup>2</sup> sol, 2 x 6 mm<sup>2</sup> sol
- 10 elastic membranes, closed cable entries, sealing range Ø 6.5-18 mm
- colour: white, RAL 9016
- for normal environment and protected outdoor

rated insulation voltage	U <sub>i</sub> = 690 V a.c./d.c.
tightening torque for terminal	1,2 Nm
material	PS (Polystyrene)

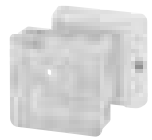
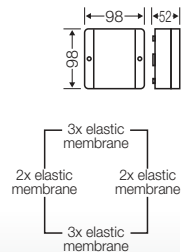

**DE 9321**

- without terminals
- 10 elastic membranes, closed cable entries, sealing range Ø 6.5-16 mm
- colour: white, RAL 9016
- for normal environment and protected outdoor

material	PS (Polystyrene)
----------	------------------

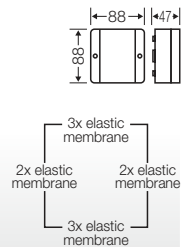

**DE 9341**

- without terminals
- 10 elastic membranes, closed cable entries, sealing range Ø 6.5-18 mm
- colour: white, RAL 9016
- for normal environment and protected outdoor

material	PS (Polystyrene)
----------	------------------

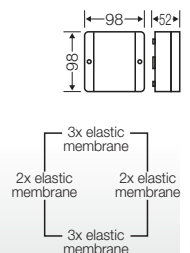



**DE 9331**

- without terminals
- 10 elastic membranes, closed cable entries, sealing range Ø 6.5-16 mm
- colour: white, RAL 9016
- with cable retention (2 pc.) for cable tie up to 6.5 mm width
- for normal environment and protected outdoor

material	PS (Polystyrene)
----------	------------------

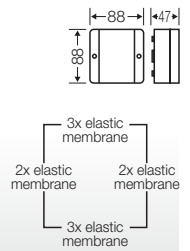

**DE 9351**

- without terminals
- 10 elastic membranes, closed cable entries, sealing range Ø 6.5-18 mm
- colour: white, RAL 9016
- with cable retention (2 pc.) for cable tie up to 6.5 mm width
- for normal environment and protected outdoor

material	PS (Polystyrene)
----------	------------------

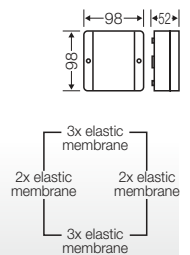

Accessories:

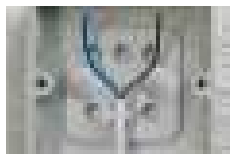

Cable retention with cable clip for fixing on the bottom

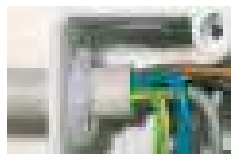

Cable retention via retention rings for cables

## DK Cable junction boxes

Cable entry via elastic membranes



### KHR 01

#### Cable retention for cable diameter 6.5 - 14 mm

- set with 10 x 6 cable retention rings
- 30 pieces for cable diameter 6,5 - 10 mm
- 30 pieces for cable diameter 10 - 14 mm



### KHR 02

#### Cable retention for cable diameter 10 - 16 mm

- set with 10 x 6 cable retention rings
- 30 pieces for cable diameter 10 - 14 mm
- 30 pieces for cable diameter 13 - 16 mm



### DK ZE 10

#### Cable retention

- set with 10 pieces
- for fixing in the bottom part of DK-cable junction boxes
- cable retention with cable clip up to 6.5 mm



DK ZE 10 Cable retention with cable clip for fixing on the bottom



KHR .. Cable retention via retention rings for cables

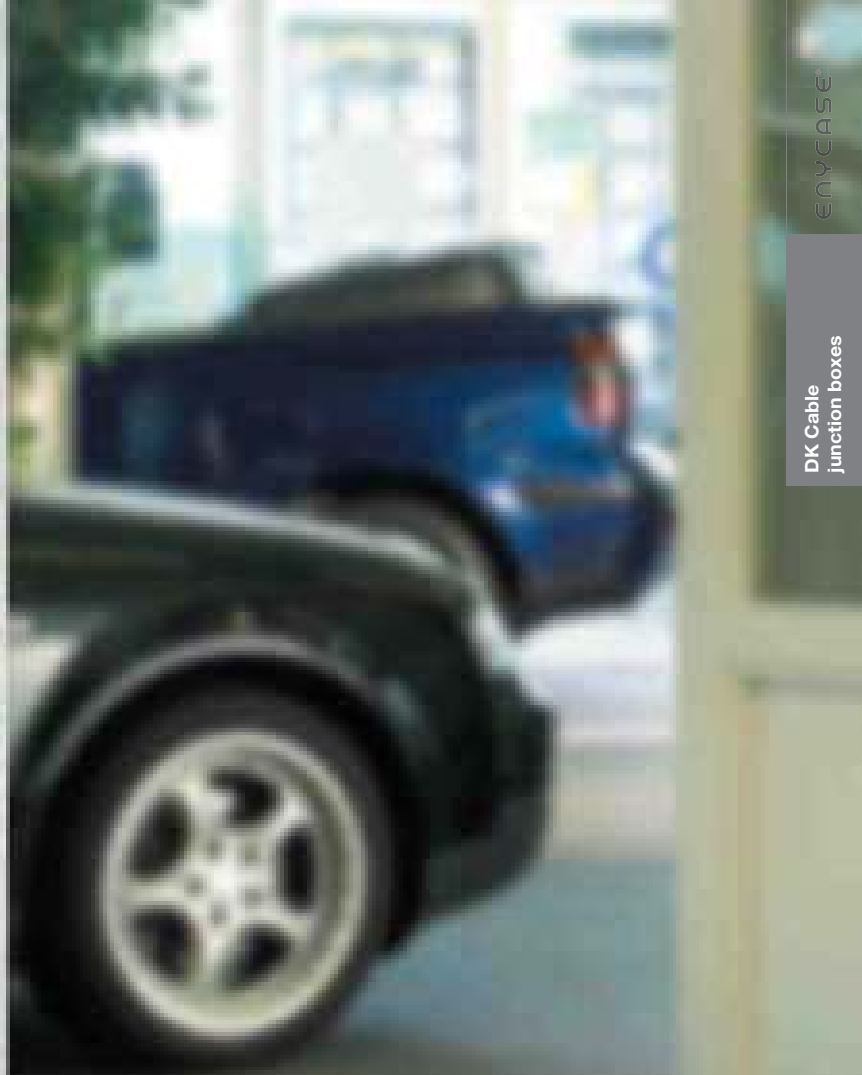

### DK Cable junction boxes

**For normal environment and protected outdoor**  
**Cable entry via elastic membranes in bottom and box walls**

- Cable entry from the rear via elastic membranes in the bottom
- Cable entry via elastic membranes in the box walls
- Lid for clip-on attachment. Reducing cover fixing time
- Flexible elastic membranes - no cable glands required.  
Push through and it's done!
- Material: PS (polystyrene)
- Burning behaviour: glow wire test in accordance with IEC 60695-2-11: 750 °C, flame-retardant, self-extinguishing
- Colour: grey RAL 7035 or white RAL 9016

## DK Cable junction boxes

### Cable entry via elastic membranes in bottom and box walls

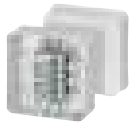

### DE 9225

1.5-2.5 mm<sup>2</sup>, Cu 3~

- with terminals
- 5-pole per pole 6 x 1.5 mm<sup>2</sup> sol, 4 x 2.5 mm<sup>2</sup> sol, 3 x 4 mm<sup>2</sup> sol
- box walls with 10 elastic membranes, closed, sealing range Ø 3-14 mm, bottom with 2 elastic membranes, closed
- lid with clip-on attachment
- colour: grey, RAL 7035
- for normal environment and protected outdoor

IP  
55

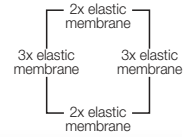
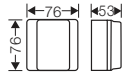

rated insulation voltage	$U_i = 690 \text{ V a.c./d.c.}$
tightening torque for terminal	1,2 Nm
material	PS (Polystyrene)



### DE 9220

- without terminals
- box walls with 10 elastic membranes, closed, sealing range Ø 3-14 mm, bottom with 2 elastic membranes, closed
- lid with clip-on attachment
- with cable retention (2 pc.) for cable tie up to 6.5 mm width
- colour: grey, RAL 7035
- for normal environment and protected outdoor

IP  
55

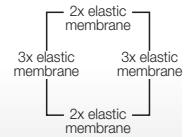
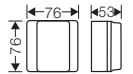

material	PS (Polystyrene)
----------	------------------

**DK Cable junction boxes**  
**cable entry via elastic membranes**  
**in bottom and box walls**



**DE 9226**

**1.5-2.5 mm<sup>2</sup>, Cu 3~**

- with terminals
- 5-pole per pole 6 x 1.5 mm<sup>2</sup> sol, 4 x 2.5 mm<sup>2</sup> sol, 3 x 4 mm<sup>2</sup> sol
- box walls with 10 elastic membranes, closed, sealing range Ø 3-14 mm, bottom with 2 elastic membranes, closed
- lid with clip-on attachment
- colour: white, RAL 9016
- for normal environment and protected outdoor

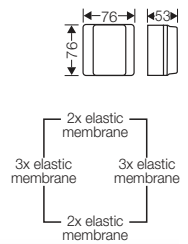

rated insulation voltage	U <sub>i</sub> = 690 V a.c./d.c.
tightening torque for terminal	1,2 Nm
material	PS (Polystyrene)



**DE 9221**

- without terminals
- box walls with 10 elastic membranes, closed, sealing range Ø 3-14 mm, bottom with 2 elastic membranes, closed
- lid with clip-on attachment
- with cable retention (2 pc.) for cable tie up to 6.5 mm width
- colour: white, RAL 9016
- for normal environment and protected outdoor

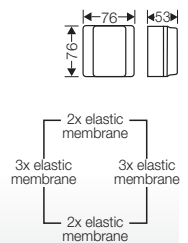

material	PS (Polystyrene)
----------	------------------

Accessories:

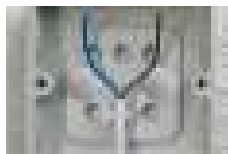

Cable retention with cable clip for fixing on the bottom

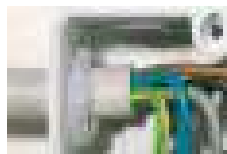

Cable retention via retention rings for cables

## DK Cable junction boxes

cable entry via elastic membranes  
in bottom and box walls



### DK ZE 10

#### Cable retention

- set with 10 pieces
- for fixing in the bottom part of DK-cable junction boxes
- cable retention with cable clip up to 6.5 mm



### KHR 01

#### Cable retention

#### for cable diameter 6.5 - 14 mm

- set with 10 x 6 cable retention rings
- 30 pieces for cable diameter 6,5 - 10 mm
- 30 pieces for cable diameter 10 - 14 mm



### KHR 02

#### Cable retention

#### for cable diameter 10 - 16 mm

- set with 10 x 6 cable retention rings
- 30 pieces for cable diameter 10 - 14 mm
- 30 pieces for cable diameter 13 - 16 mm



### DE MB 10

#### Assembly bracket

- external brackets 10 units
- material: thermoplastics
- for quick installation of cable junction boxes DE 922. and DN 20..

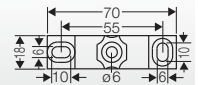

DK ZE 10 Cable retention with cable clip for fixing on the bottom



KHR .. Cable retention via retention rings for cables



## DK Cable junction boxes

### Accessories

DIN rails	118
Terminals	119-121
Label for cable junction boxes	122
Cable feed-throughs for knockouts in the rear walls	122
Cable retention system	123
Removable grommets, removable trunking or conduit adapter	123
Labelling system for circuit description, sealing facility	124
Accessories for cable junction boxes from 70 mm <sup>2</sup> onwards	125-126

**DK Cable junction boxes**  
 „Weatherproof“, for outdoor installation  
 Accessories



**DK TS 02**

**DIN rail**

- for cable junction boxes DK 02...., KF 02....
- for the installation of terminal blocks
- with fixing screws

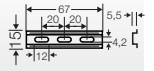

**DK TS 04**

**DIN rail**

- for cable junction boxes DK 04 ...., KF 04....
- for the installation of terminal blocks
- with fixing screws

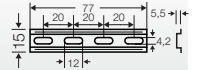

**DK TS 06**

**DIN rail**

- for cable junction boxes DK 06.... , KF 06....
- for the installation of terminal blocks
- with fixing screws

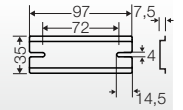

**DK TS 10**

**DIN rail**

- for cable junction boxes DK 10...., KF 10....
- for the installation of terminal blocks
- with fixing screws

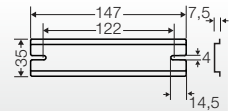

**DK TS 16**

**DIN rail**

- for cable junction boxes DK 16...., KF 16....
- for the installation of terminal blocks
- with fixing screws

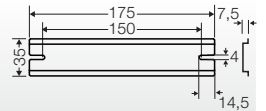

**DK TS 25**

**DIN rail**

- for cable junction boxes DK 25...., KF 25....
- for the installation of terminal blocks
- with fixing screws

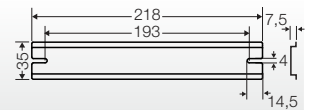

**DK TS 35**

**DIN rail**

- for cable junction boxes DK 35...., KF 35....
- for the installation of terminal blocks
- with fixing screws

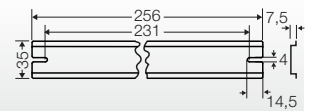

**DK TS 50**

**DIN rail**

- for cable junction boxes DK 50...., KF 50....
- for the installation of terminal blocks
- with fixing screws

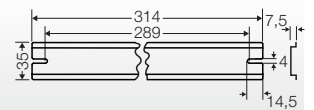



**DK KL 02**

**Rated connecting capacity: 1.5-4 mm<sup>2</sup>, Cu**

- terminal with 2 clamping units per pole
- 5-pole per pole 8 x 0,75 mm<sup>2</sup> f, 6 x 1,5 mm<sup>2</sup> sol / f, 4 x 2,5 mm<sup>2</sup> sol / f, 2 x 4 mm<sup>2</sup> sol / f
- current carrying capacity: 20 A
- for installation in cable junction boxes via terminal support
- can be used on terminal supports DK KH 02, DK KH 04 and DK KH 06



rated insulation voltage	U <sub>i</sub> = 690 V a.c./d.c.
dismantling length	10 mm
tightening torque for terminal	0.5 Nm



**DK KH 02**

**Support for terminals**

- support for terminal DK KL 02
- can be used in cable junction boxes DK 02.. X, DK 02.. XX, KF 02.. X



**DK KL 04**

**Rated connecting capacity: 1.5-6 mm<sup>2</sup>, Cu**

- terminal with 2 clamping units per pole
- 5-pole per pole 8 x 1,5 mm<sup>2</sup> sol / f, 6 x 2,5 mm<sup>2</sup> sol / f, 4 x 4 mm<sup>2</sup> sol / f, 2 x 6 mm<sup>2</sup> sol / f
- current carrying capacity: 32 A
- for installation in cable junction boxes via terminal support
- can be used on terminal supports DK KH 04 and DK KH 06



rated insulation voltage	U <sub>i</sub> = 690 V a.c./d.c.
dismantling length	10 mm
tightening torque for terminal	0.7 Nm



**DK KH 04**

**Support for terminals**

- support for terminals DK KL 02 and DK KL 04
- can be used in cable junction boxes DK 04.. X, DK 04.. XX, KF 04.. X



**DK KL 06**

**Rated connecting capacity: 1.5-10 mm<sup>2</sup>, Cu**

- terminal with 2 clamping units per pole
- 5-pole per pole 6 x 1,5 mm<sup>2</sup> sol / f, 4 x 2,5 mm<sup>2</sup> sol / f, 4 x 4 mm<sup>2</sup> sol / f, 4 x 6 mm<sup>2</sup> sol / f, 2 x 10 mm<sup>2</sup> sol / f
- current carrying capacity: 40 A
- for installation in cable junction boxes via terminal support
- can be used on terminal support DK KH 06

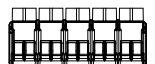

rated insulation voltage	U <sub>i</sub> = 690 V a.c./d.c.
dismantling length	12 mm
tightening torque for terminal	1.5 Nm

**DK Cable junction boxes**  
 „Weatherproof“, for outdoor installation  
 Accessories



**DK KH 06**

**Support for terminals**

- support for terminals DK KL 02, DK KL 04 and DK KL 06
- can be used in cable junction boxes DK 06.. X, DK 06.. XX, DK 10.. X, DK 10..XX, KF 06.. X and KF 10.. X



**DK KS 10**

**Rated connecting capacity: 2.5-16 mm<sup>2</sup>, Cu**

- terminal with 2 clamping units per pole
- 5-pole per pole 6 x 2.5 mm<sup>2</sup> sol, 4 x 4 mm<sup>2</sup> sol, 4 x 6 mm<sup>2</sup> sol, 4 x 10 mm<sup>2</sup> sol, 2 x 16 mm<sup>2</sup> s
- current carrying capacity: 63 A
- for insertion in cable junction boxes
- for cable junction boxes DK 10.. X, DK 10.. XX, KF 10.. X
- complete with fixing elements



rated insulation voltage	U <sub>i</sub> = 690 V a.c./d.c.
dismantling length	11 mm
tightening torque for terminal	2.0 Nm



**DK KS 16**

**Rated connecting capacity 6-25 mm<sup>2</sup>, Cu**

- terminal with 2 clamping units per pole
- 5-pole per pole 6 x 6 mm<sup>2</sup> sol, 6 x 10 mm<sup>2</sup> sol/ f\*, 4 x 16 mm<sup>2</sup> s/ f\*, 4 x 25 mm<sup>2</sup> s/ f\*, 2 x 35 mm<sup>2</sup> s/ f\*
- current carrying capacity: 102 A
- for insertion in cable junction boxes
- for cable junction boxes DK 16.. X, DK 16.. XX, KF 16.. X
- complete with fixing elements



rated insulation voltage	U <sub>i</sub> = 690 V a.c./d.c.
dismantling length	16 mm
tightening torque for terminal	3.0 Nm



**DK KS 25**

**Rated connecting capacity: 6-35 mm<sup>2</sup>, Cu**

- terminal with 2 clamping units per pole
- 5-pole per pole 6 x 6 mm<sup>2</sup> sol, 6 x 10 mm<sup>2</sup> sol/ f\*, 4 x 16 mm<sup>2</sup> s/ f\*, 4 x 25 mm<sup>2</sup> s/ f\*, 2 x 35 mm<sup>2</sup> s/ f\*
- current carrying capacity: 102 A
- for insertion in cable junction boxes
- for koblingsboxer DK 25.. X, DK 25.. XX, KF 25.. X
- complete with fixing elements



rated insulation voltage	U <sub>i</sub> = 690 V a.c./d.c.
dismantling length	16 mm
tightening torque for terminal	3.0 Nm



**DK KS 35**

**Rated connecting capacity 16-35 mm<sup>2</sup>, Cu**

- terminal with 2 clamping units per pole
- 5-pole per pole 6 x 16 mm<sup>2</sup> s, 4 x 25 mm<sup>2</sup> s, 4 x 35 mm<sup>2</sup> s, 2 x 50 mm<sup>2</sup> s
- current carrying capacity: 125 A
- for insertion in cable junction boxes
- for cable junction boxes DK 35...., KF 35....
- complete with fixing elements

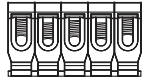

rated insulation voltage	U <sub>i</sub> = 690 V a.c./d.c.
dismantling length	20 mm
tightening torque for terminal	12.0 Nm



**DK KS 50**

**Rated connecting capacity: 16-50 mm<sup>2</sup>, Cu**

- terminal with 2 clamping units per pole
- 5-pole per pole 6 x 16 mm<sup>2</sup> s, 4 x 25 mm<sup>2</sup> s, 4 x 35 mm<sup>2</sup> s, 4 x 50 mm<sup>2</sup> s
- current carrying capacity: 150 A
- for insertion in cable junction boxes
- for cable junction boxes DK 50...., KF 50....
- complete with fixing elements

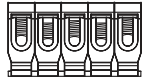

rated insulation voltage	U <sub>i</sub> = 690 V a.c./d.c.
dismantling length	20 mm
tightening torque for terminal	12.0 Nm

**DK Cable junction boxes**  
„Weatherproof“, for outdoor installation  
Accessories



**DK BZ 5**

**Labelling material**

- set with 5 pieces
- for cable junction boxes types DK ....., RK ....., KF ..... or FK ..... from 2.5 to 50 mm<sup>2</sup>, connectable to base of the box
- for attaching of labelling strips or marking with felt tip pen
- inscribable surface 24 x 41 mm
- suitable for labelling according to the identification system for power stations "KKS"

material

PC (polycarbonate)



**LDM 25 G**

**Cable feed-through  
for knockouts in the rear wall M 25**

IP  
66/67

- sealing range: Ø 8-17 mm
- bore-hole: Ø 25.5 mm
- wall thickness 0.5-3.5 mm
- for indoor - normal environment and (or) protected outdoor installation
- ambient temperature - 25 °C to + 55 °C
- Glow wire test IEC 60695-2-11: 750 °C

material

TPE (-25° to +80°C)



**LDM 25 B**

**Cable feed-through  
for knockouts in the rear wall M 25**

IP  
66/67

- sealing range: Ø 8-17 mm
- bore-hole: Ø 25.5 mm
- wall thickness 0.5-3.5 mm
- for indoor - normal environment and (or) protected outdoor installation
- ambient temperature - 25 °C to + 55 °C
- Glow wire test IEC 60695-2-11: 750 °C

material

TPE (-25° to +80°C)



**LDM 32 G**

**Cable feed-through  
for knockouts in the rear wall M 32**

IP  
66/67

- sealing range: Ø 12-24 mm
- bore-hole: Ø 32.5 mm
- wall thickness 0,5-4,5 mm
- for indoor - normal environment and (or) protected outdoor installation
- ambient temperature - 25 °C to + 55 °C
- Glow wire test IEC 60695-2-11: 750 °C

material

TPE (-25° to +80°C)



**LDM 32 B**

**Cable feed-through  
for knockouts in the rear wall M 32**

IP  
66/67

- sealing range: Ø 12-24 mm
- bore-hole: Ø 32.5 mm
- wall thickness 0,5-4,5 mm
- for indoor - normal environment and (or) protected outdoor installation
- ambient temperature - 25 °C to + 55 °C
- Glow wire test IEC 60695-2-11: 750 °C

material

TPE (-25° to +80°C)



**KHR 01**

**Cable retention  
for cable diameter 6.5 - 14 mm**

- set with 10 x 6 cable retention rings
- 30 pieces for cable diameter 6,5 - 10 mm
- 30 pieces for cable diameter 10 - 14 mm



**KHR 02**

**Cable retention  
for cable diameter 10 - 16 mm**

- set with 10 x 6 cable retention rings
- 30 pieces for cable diameter 10 - 14 mm
- 30 pieces for cable diameter 13 - 16 mm



**DKL 04**

**Rated connecting capacity: 1.5-6 mm<sup>2</sup>, Cu**

- for insertion in cable junction boxes
- 5-pole per pole 6 x 1.5 mm<sup>2</sup> sol, 4 x 2.5 mm<sup>2</sup> sol, 3 x 4 mm<sup>2</sup> sol, 2 x 6 mm<sup>2</sup> sol
- for cable junction boxes D 8020, D 8120, D 8040, D 9020, D 9120, D 9040, D 9220, DP 9020, DP 9220, DE 9320, DE 9321, DE 9340, DE 9341
- complete with fixing elements



rated insulation voltage	U <sub>i</sub> = 690 V a.c./d.c.
dismantling length	11 mm
tightening torque for terminal	1,2 Nm



**DPS 02**

**Removable grommet**



- degree of protection: IP 54 sealing range Ø 10-13.5 mm
- for retrofitting
- for cable junction boxes DP 9020, DP 9220, DP 9025, DP 9221, DP 9222, DP 9026, DPC 9225



**EKA 20**

**Removable trunking adapter**



- degree of protection: IP 54 sealing range Ø 10-13.5 mm
- for mini trunking up to 20 x 20 mm
- for cable junction boxes DP 9020, DP 9220, DP 9025, DP 9221, DP 9222, DP 9026, DPC 9225



**ERA 20**

**Removable conduit adapter**



- degree of protection: IP 54 sealing range Ø 10-13.5 mm
- for wiring conduits M 20
- for cable junction boxes DP 9020, DP 9220, DP 9025, DP 9221, DP 9222, DP 9026, DPC 9225



### DK BS 5

#### Labelling system for circuit description

- set with 5 pieces
- for cable junction boxes type D from 2.5 to 50 mm<sup>2</sup>, can be inserted into cover fixing ducts.
- for attaching of labelling strips or marking with felt tip pen
- inscribable surface of 45 x 30 mm
- suitable for labelling according to the identification system for power stations "KKS"
- label template on the Internet  
at [www.hensel-electric.de](http://www.hensel-electric.de) - download area
- cannot be used in cable junction boxes type D 2.5 to 4 mm<sup>2</sup> with sealing facility

material

PC (polycarbonate)



### PLS 06

#### Sealing device

- for retrofitting, without sealing wire and without seal
- for cable junction boxes 2.5 mm<sup>2</sup>: DE 9x2x, DP 9x2x, DPC 9225
- for cable junction boxes 4 mm<sup>2</sup>: DE 9x4x



**Mi AL 40**

**4 stainless steel external brackets**

- for external fixing of enclosures

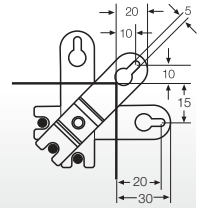

**Mi FM 40**

**Flange**

**knockouts: 2 x M 25/32, 5 x M 32/40**

- box wall 300 mm
- with fixing wedges and seal

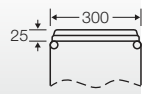

**Mi FM 50**

**Flange**

**knockouts: 2 x M 20, 4 x M 32/40/50**

- box wall 300 mm
- with fixing wedges and seal

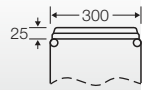

**Mi FM 60**

**Flange**

**knockouts: 3 x M 40/50/63**

- box wall 300 mm
- with fixing wedges and seal

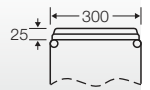

**Mi FM 63**

**Flange with cable arrangement space**

**knockouts: 3 x M 40/50/63**

- box wall 300 mm
- with fixing wedges and seal

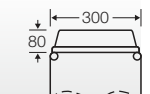

**Mi FP 70**

**Flange**

**sealing range: 1 x Ø 30-72 mm**

- box wall 300 mm
- with fixing wedges and seal

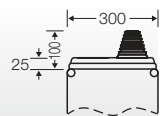

**Mi FP 72**

**Flange**

**sealing range: 2 x each Ø 30-72 mm**

- box wall 300 mm
- with fixing wedges and seal

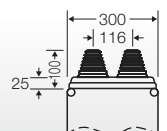

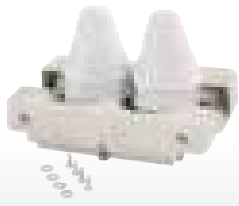
**DK Cable junction boxes**Accessories for cable junction boxes from 70 mm<sup>2</sup> onwards**Mi FP 82****Cable insert****sealing range: 2 x each Ø 30-72 mm**

- box wall 300 mm
- divisible for cable insertion from the front
- degree of protection IP 54 only with additional strain and pressure relief (e.g. Mi ZE 62)

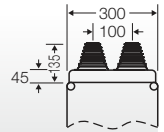
**KST 82****Stepped grommet****sealing range: Ø 30-72 mm**

- for retrofitting of cable insertion Mi FP 82
- for indoor - normal environment and (or) protected outdoor installation
- ambient temperature - 25 °C to + 35 °C

**Mi ZE 62****Cable strain relief****for 2 cables with max. 60 mm external diameter**

- with fixing rail 284 mm long
- to be used only in connection with cable insertion Mi FP 82

**Mi SA 2****Dust protection cover**

- for box sizes 1 to 4
- for 2 lid fittings



## DK Cable junction boxes

### Technical details

Dimensions in mm	128-131
Terminals	132-135
Operating and ambient conditions	136-138
Standards and regulations	139
Technical details FK cable junction boxes with intrinsic fire resistance	140-141

DK 0200 G  
DK 0200 R

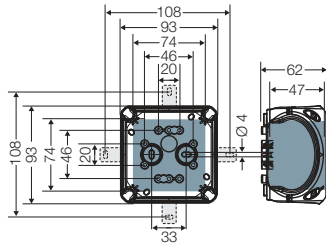

DK 0400 G  
DK 0400 R

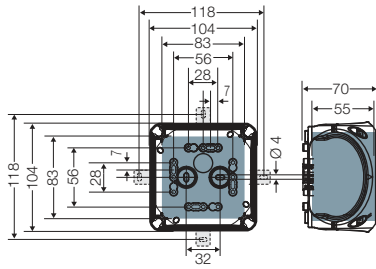

DK 0600 G

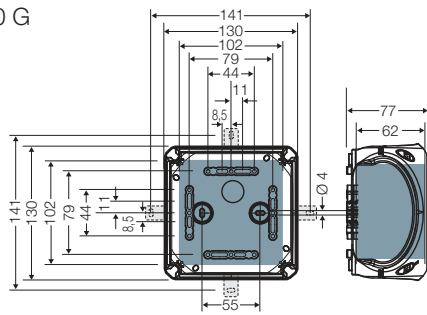

DK 1000 G

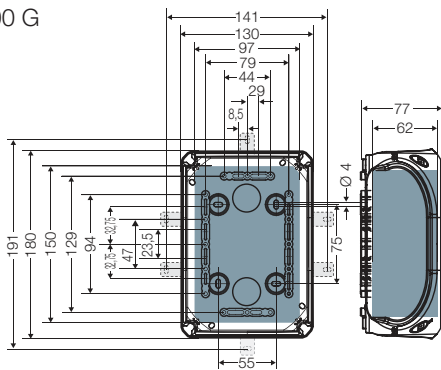

DK 1600 G

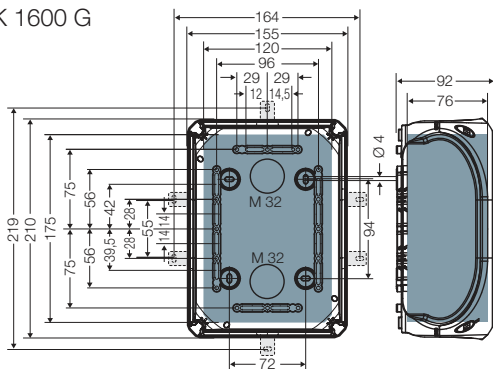

DK 2500 G

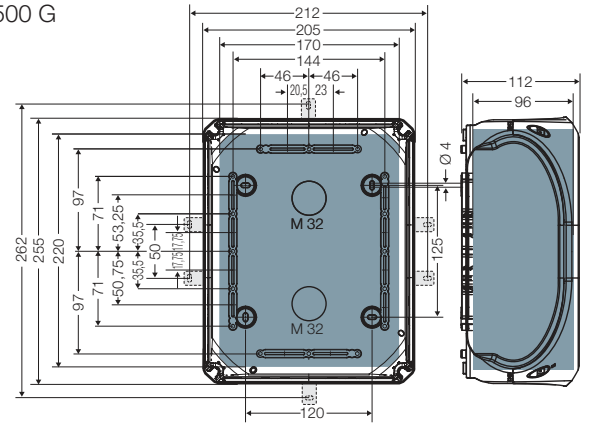

DK 3500 G

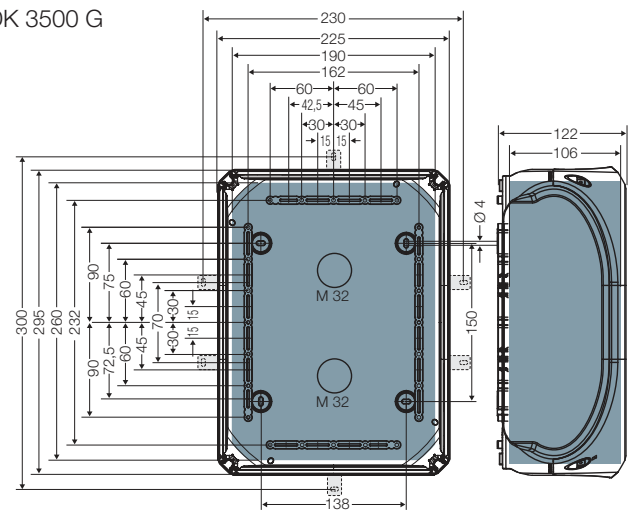

DK 5000 G

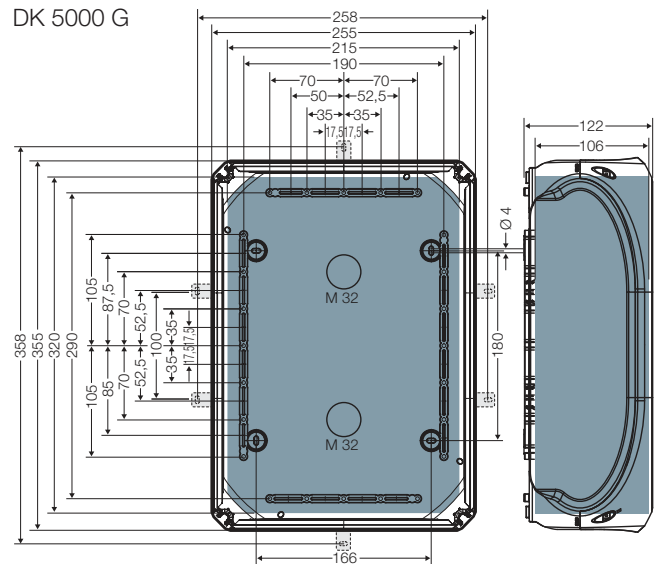

KF 0200 G  
KF 0200 B

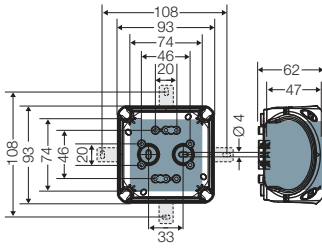

KF 0400 G  
KF 0400 B

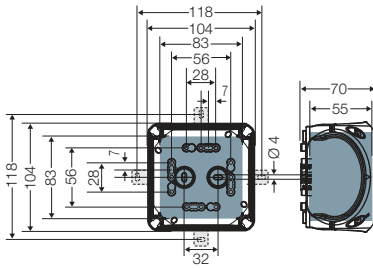

KF 0600 G  
KF 0600 B

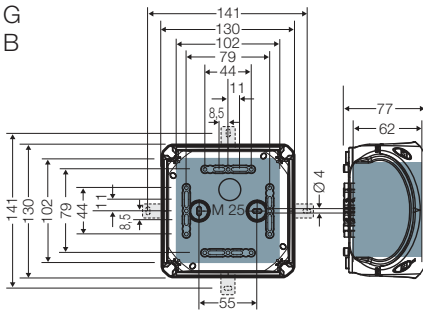

KF 1000 G  
KF 1000 B

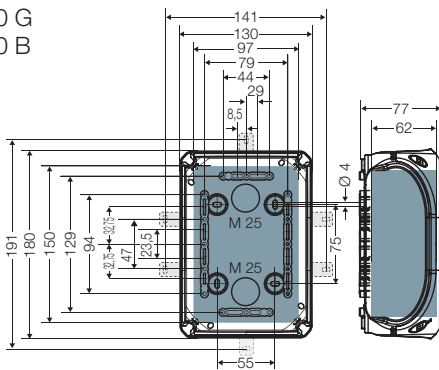

KF 1600 G  
KF 1600 B

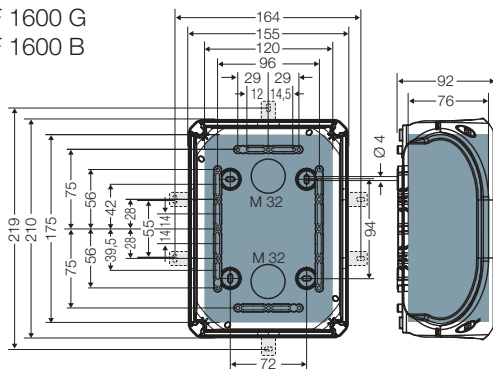

KF 2500 G  
KF 2500 B

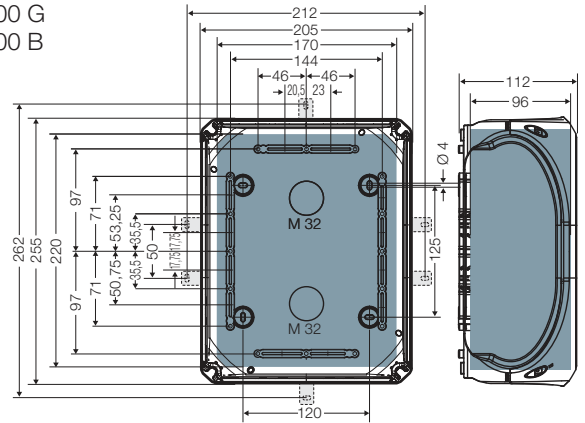

KF 3500 G  
KF 3500 B

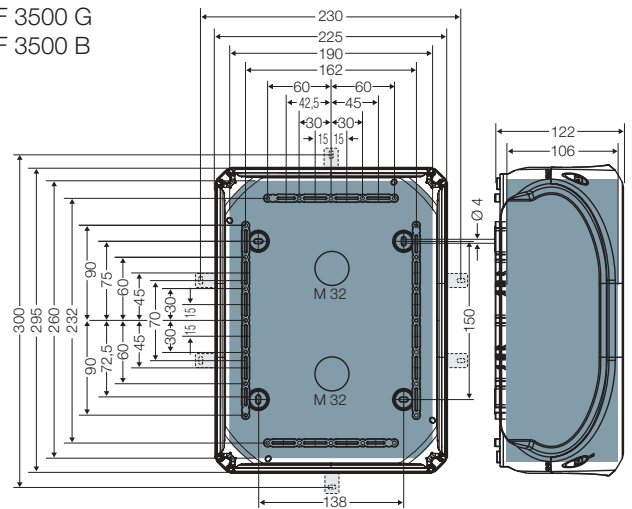

KF 5000 G  
KF 5000 B

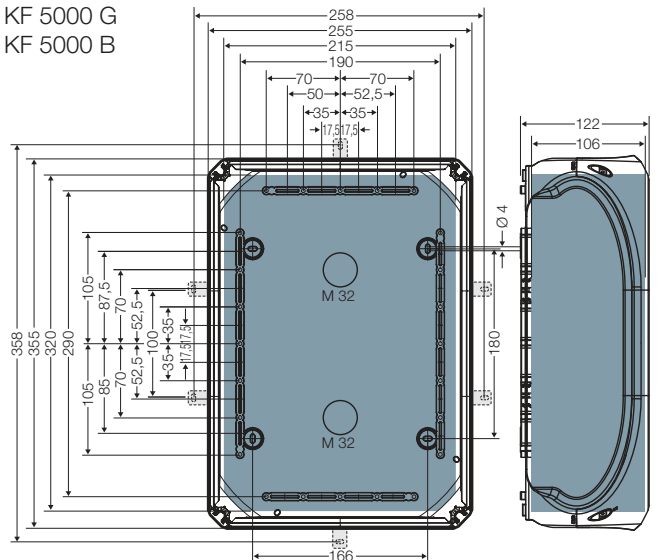

= usable installation space  
with mounted cable glands

KF 0200 H  
KF 0200 C

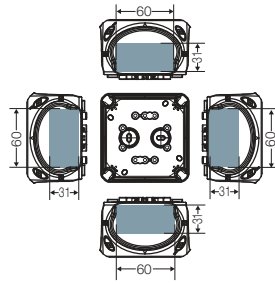

KF 2500 H  
KF 2500 C

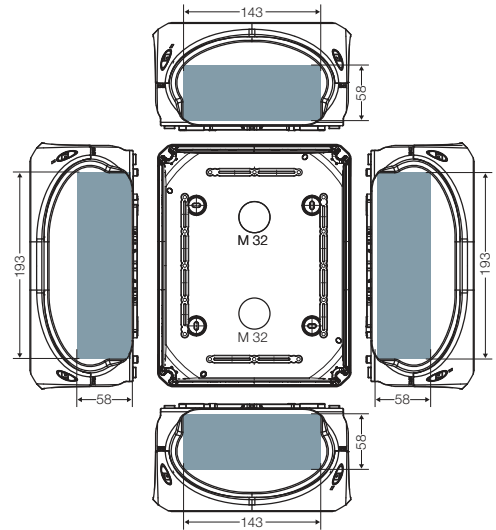

KF 0400 H  
KF 0400 C

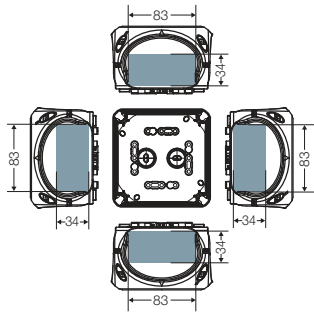

KF 3500 H  
KF 3500 C

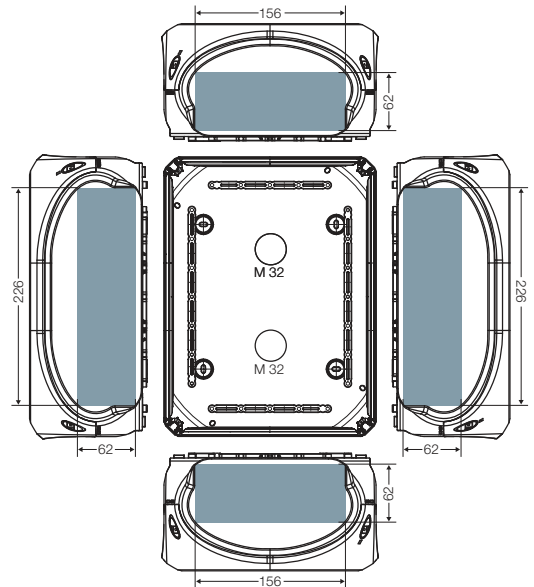

KF 0600 H  
KF 0600 C

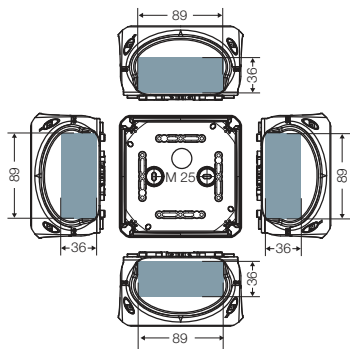

KF 1000 H  
KF 1000 C

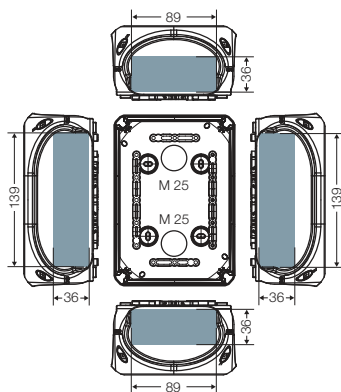

KF 5000 H  
KF 5000 C

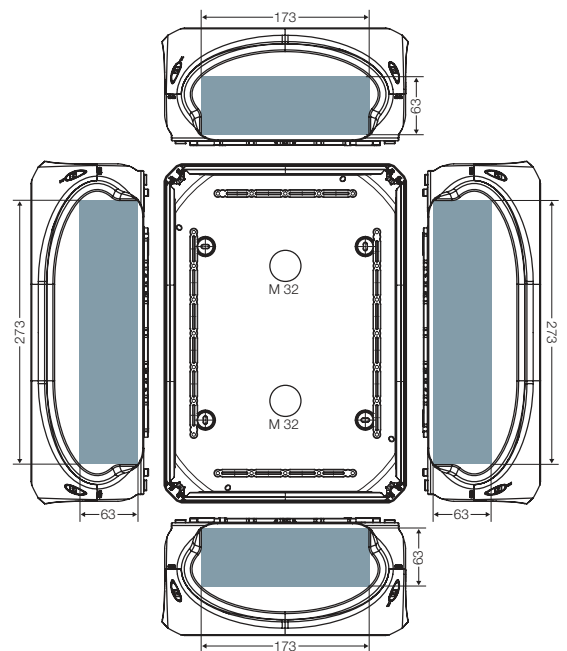

KF 1600 H  
KF 1600 C

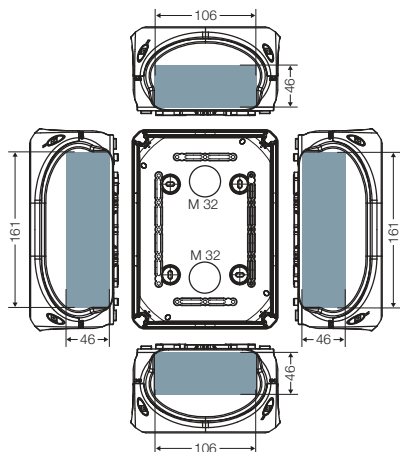

 = usable installation area in box walls

DE 9320  
DE 9321

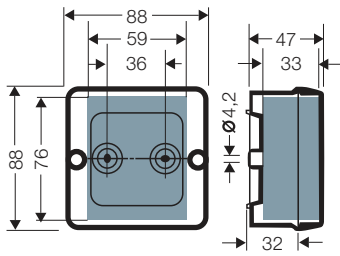

DE 9340  
DE 9341

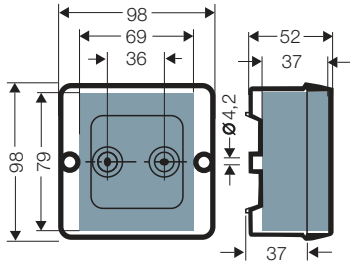

DP 9020

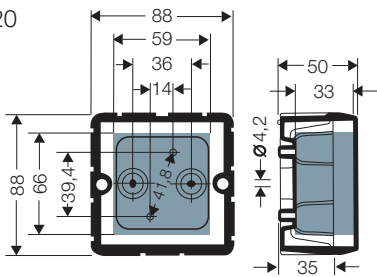

DP 9220

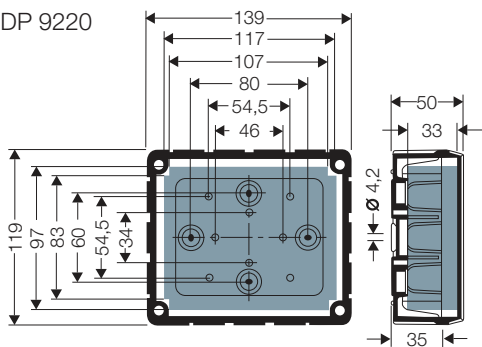

K 7055  
K 7004  
K 7005  
K 7042  
K 7052  
K 9951  
K 1204  
K 1205

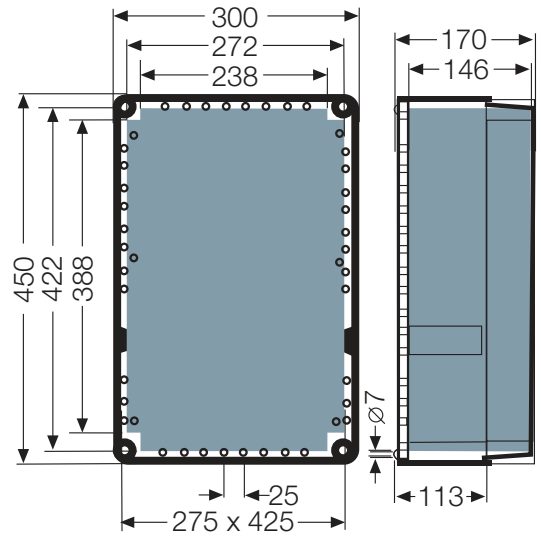

K 2401  
K 2404  
K 2405

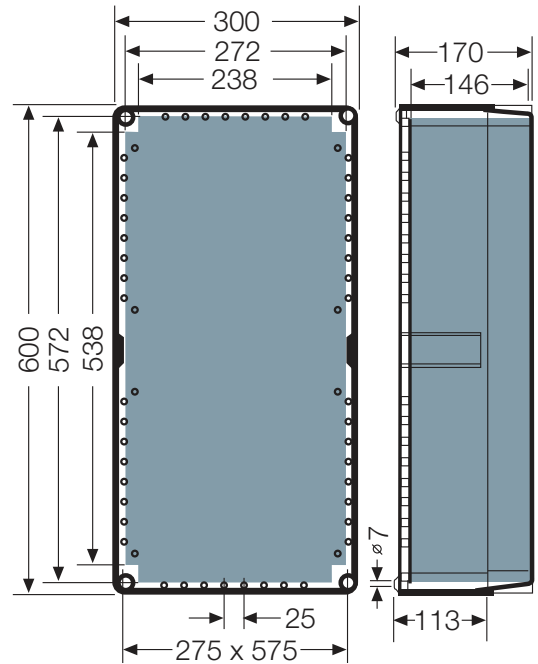









 = usable installation space  
with mounted cable glands

Connecting terminals for copper conductors (Cu)

Hint: The connection of different types of conductors and/or different cross-sections at one clamping unit is not permitted.

f<sup>1</sup> = flexible with end ferrule



Type of terminal	Fixed in cable junction boxes	Clamping units per pole	Rated connecting capacity mm <sup>2</sup> and types of conductors	Conductors to be connected per pole	Tightening torque	Current carrying capacity	Rated cross section of terminal
 DK KL 02	DK 0202 G, DK 0402 G, DK 0202 R, DK 0402 R KF 0202 G, KF 0202 B KF 0402 G, KF 0402 B WP 0202 G, WP 0202 B WP 0402 G, WP 0402 B	2	4 sol/f 2.5 sol/f 1.5 sol/f 0.75 f	1-2 1-4 1-6 1-8	0.5 Nm	20 A	4 mm <sup>2</sup>
 DK KL 04	DK 0404 G, DK 0604 G, DK 0404 R, DK 0604 R KF 0404 G, KF 0404 B KF 0604 G, KF 0604 B WP 0404 G, WP 0404 B WP 0604 G, WP 0604 B	2	6 sol/f 4 sol/f 2.5 sol/f 1.5 sol/f	1-2 1-4 1-6 1-8	0.7 Nm	32 A	6 mm <sup>2</sup>
 DK KL 06	DK 0606 G, DK 1006 G KF 0606 G, KF 0606 B KF 1006 G, KF 1006 B WP 0606 G, WP 0606 B	2	10 sol/f 6 sol/f 4 sol/f 2.5 sol/f 1.5 sol/f	1-2 1-4 1-4 1-4 1-6	1.5 Nm	40 A	10 mm <sup>2</sup>
 DK KS 10	DK 1010 G, DK 1610 G KF 1010 G, KF 1010 B KF 1610 G, KF 1610 B WP 1010 G, WP 1010 B	2	16 s 10 sol 6 sol 4 sol 2.5 sol. f <sup>1</sup>	1-2 1-4 1-4 1-4 2-6	2 Nm	63 A	16 mm <sup>2</sup>
 DK KS 16	DK 1616 G KF 1616 G KF 1616 B	2	35 s. f <sup>1</sup> 25 s. f <sup>1</sup> 16 s. f <sup>1</sup> 10 sol. f <sup>1</sup> 6 sol	1-2 1-4 1-4 1-6 1-6	3 Nm	102 A	35 mm <sup>2</sup>
 DK KS 25	DK 2525 G KF 2525 G KF 2525 B	2	35 s. f <sup>1</sup> 25 s. f <sup>1</sup> 16 s. f <sup>1</sup> 10 sol. f <sup>1</sup> 6 sol	1-2 1-4 1-4 1-6 1-6	3 Nm	102 A	35 mm <sup>2</sup>
 DK KS 35	DK 3535 G KF 3535 G KF 3535 B	2	50 s 35 s 25 s 16 s	1-2 1-4 1-4 1-6	12 Nm	125 A	50 mm <sup>2</sup>
 DK KS 50	DK 5054 G DK 5055 G	2	50 s 35 s 25 s 16 s	1-4 1-4 1-4 1-6	12 Nm	150 A	50 mm <sup>2</sup>



**Connecting terminals for copper conductors (Cu)**

**Hint:** The connection of different types of conductors and/or different cross-sections at one clamping unit is not permitted.

f<sup>1</sup> = flexible with end ferrule

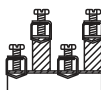
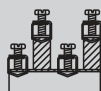
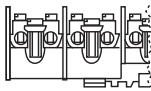
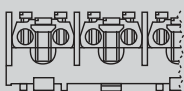



Type of terminal	Fixed in cable junction boxes	Clamping units per pole	Rated connecting capacity mm <sup>2</sup> and types of conductors	Conductors to be connected per pole	Tightening torque	Current carrying capacity	Rated cross section of terminal
 <b>DKL 04</b>	<b>DP 9025, DP 9221, DP 9222, DE 9325, DE 9326, DE 9345, DE 9346</b>	1	6 sol 4 sol 2.5 sol 1.5 sol	1-2 1-3 1-4 1-6	1.2 Nm	–	<b>6 mm<sup>2</sup></b>
 <b>KLS 51</b>	<b>K 7055</b>	2	50 s 35 s 25 s 16 s	1-4 1-4 1-4 1-6	12 Nm	150 A	<b>50 mm<sup>2</sup></b>
 <b>4 x KLS 54</b>	<b>K 7004</b>	4	70 s 50 s 35 s 25 s 16 s	1-4 1-4 1-4 1-4 1-4	10 Nm	216 A	<b>70 mm<sup>2</sup></b>
 <b>5 x KLS 55</b>	<b>K 7005</b>	4	70 s 50 s 35 s 25 s 16 s	1-4 1-4 1-4 1-4 1-4	10 Nm	216 A	<b>70 mm<sup>2</sup></b>
	<b>DK 2524 S</b> <b>DK 3525 S</b>	Incoming 2 Outgoing 4	25 r 16 r	1-2 1-4	3 Nm	80 A	<b>25 mm<sup>2</sup></b>
	<b>DK 3534 S</b> <b>DK 5035 S</b>	Incoming 2 Outgoing 4	35 r 35 r	1-2 1-4	4 Nm 3 Nm	100 A	<b>35 mm<sup>2</sup></b>

**Terminal for equipotential bonding:**

**DP 9026** for 1 continued conductor 4-25 mm<sup>2</sup> and 5 conductors 4-10 mm<sup>2</sup> (16 mm<sup>2</sup> sol)



Terminals

	K 7042 / K 7052	K 1204 / K 1205		K 2404 / K 2405	
<b>Rated connecting capacity</b>	95 mm <sup>2</sup>	150 mm <sup>2</sup>		240 mm <sup>2</sup>	
<b>Current carrying capacity</b>	160 A	250 A		400 A	
<b>Tightening torque</b>	20 Nm	20 Nm		40 Nm	
<b>Clamping units per pole</b>	2	2	4	2	4
 <b>Conductor cross section Cu/Alu<sup>1)</sup> sol (round)</b>	10-50	16-50	16-50	25-50	25-50
 <b>Conductor cross section Cu/Alu<sup>1)</sup> s (round), f (flexible)</b>	16-95	16-150	16-70	25-240	25-120
 <b>Conductor cross section Cu/Alu<sup>1)</sup> sol (sector)</b>	50-95	50-150	50-70	50-185	50-120
 <b>Conductor cross section Cu s (sector)</b>	35-95	35-150	35-70	35-240	35-120
 <b>Conductor cross section Alu<sup>1)</sup> s (sector)</b>	35-70	50-120	35-50	95-185	50-95

1) Before connecting, aluminum conductors must be pre-treated according to the appropriate technical recommendations. The connections must be checked at regular intervals and maintained after 6 months at the latest.

FIXCONNECT® technology

Type	Clamping units per pole	Rated connecting capacity per types of conductors		Current carrying capacity
		r (rigid)	f (flexible)	
<b>DPC 9225</b>	4	1.5 - 4 mm <sup>2</sup>	1.5 - 4 mm <sup>2</sup> *)	32 A
<b>KC 9045</b>	4	1.5 - 4 mm <sup>2</sup>	1.5 - 4 mm <sup>2</sup> *)	32 A
<b>KC 9255</b>	4	2.5 - 10 mm <sup>2</sup>	2.5 - 10 mm <sup>2</sup>	57 A
<b>KC 9355</b>	4	2.5 - 16 mm <sup>2</sup>	2.5 - 16 mm <sup>2</sup>	76 A

\*) Without ferrule; clamping unit needs to be opened with a screwdriver when conductor is inserted.

	Boxes with terminals		Removable grommets	Boxes with terminals
	<b>D ...</b> , <b>DP ...</b> , <b>DPC ...</b> , <b>DE ...</b> , <b>KC ...</b> , <b>K ...</b> , <b>RK ...</b> , <b>DN ...</b>	<b>K 7055</b> <b>K 7004/5</b> <b>K 9951</b> <b>K 1204/5</b> <b>K 2404/5</b> <b>K 2401</b> <b>Mi FM ..</b>	<b>EKA 20</b> , <b>ERA 20</b> , <b>DPS 02</b>	<b>KF ... G</b> <b>KF ... B</b>
<b>Application area</b>	Suitable for indoor installation and outdoor installation, protected against weather influences		Suitable for for <b>outdoor installation</b> (harsh environment and/or outdoor). To reduce the formation and accumulation of condensed water see technical information.	
<b>Resistant to occasional cleaning procedures</b>			<b>Resistance to occasional cleaning procedures (direct jet)</b> with high-pressure cleaner without cleaning additives, water pressure: max 100 bar, water temperature: max 80 °C, distance ≥ 0.15 m, in accordance with DIN EN 60529:2014-09 (IEC 60529:2013) = IP 69. <b>Box and cable entries at least IP 66.</b>	
<b>Ambient temperature</b> - Average value over 24 hours - Maximum value - Minimum value	+ 35 °C + 40 °C - 25 °C	+ 35 °C + 40 °C - 25 °C	+ 35 °C + 40 °C - 25 °C	+ 55 °C + 70 °C - 25 °C
<b>Relative humidity</b> - short-time	50% at 40 °C 100% at 25 °C	50% at 40 °C 100% at 25 °C	- -	50% at 40 °C 100% at 25 °C
<b>Fire protection</b> in the event of internal faults	Demands placed on electrical devices from standards and laws:  Minimum requirements - Glow wire test in accordance with IEC 60695-2-11: - 650 °C for boxes and cable glands - 850 °C for conducting components			
<b>Burning behaviour</b> - Glow wire test IEC 60695-2-11 - UL Subject 94	750 °C  V-2 flame-retardant self-extinguishing	960 °C  V-2 flame-retardant self-extinguishing	750 °C  - flame-retardant self-extinguishing	960 °C  V-0 flame-retardant self-extinguishing
<b>Degree of protection against mechanical load</b>	IK07 (2 Joule)	IK08 (5 Joule)	-	IK09 (10 Joule)
<b>Toxic behaviour</b>	halogen-free silicone-free	halogen-free silicone-free	halogen-free silicone-free	halogen-free silicone-free
	"Halogen-free" in accordance with IEC 60754-2 "Common test methods for cables - Determination of the amount of halogen acid gas".  <b>For material properties see technical data.</b>			

	Empty boxes	Removable grommets		Empty boxes
	<b>DK ...</b> , <b>DP ...</b> , <b>DE ...</b>	<b>EKA 20</b> , <b>ERA 20</b> , <b>DPS 02</b>	<b>LDM ...</b>	<b>KF ... G</b> , <b>KF ... B</b> <b>KF ... H</b> , <b>KF ... C</b>
<b>Application area</b>	Suitable for indoor installation and outdoor installation, protected against weather influences			Suitable for for <b>outdoor installation</b> (harsh environment and/or outdoor). To reduce the formation and accumulation of condensed water see technical information.
<b>Resistant to occasional cleaning procedures</b>				<b>Resistance to occasional cleaning procedures (direct jet)</b> with high-pressure cleaner without cleaning additives, water pressure: max 100 bar, water temperature: max 80 °C, distance ≥ 0.15 m, in accordance with DIN EN 60529:2014-09 (IEC 60529:2013) = IP 69. <b>Box and cable entries at least IP 66.</b>
<b>Ambient temperature</b>				
- Average value over 24 hours	–	+ 35 °C	+ 55 °C	+ 55 °C
- Maximum value	+ 40 °C	+ 60 °C	+ 70 °C	+ 70 °C
- Minimum value	– 25 °C	– 25 °C	– 25 °C	– 25 °C
<b>Fire protection</b> in the event of internal faults	Demands placed on electrical devices from standards and laws:  Minimum requirements - Glow wire test in accordance with IEC 60695-2-11: - 650 °C for boxes and cable glands - 850 °C for conducting components			
<b>Burning behaviour</b>				
- Glow wire test IEC 60695-2-11	750 °C	750 °C	750 °C	960 °C
- UL Subject 94	V-2 flame-retardant self-extinguishing	– flame-retardant self-extinguishing	– flame-retardant self-extinguishing	V-0 flame-retardant self-extinguishing
<b>Degree of protection against mechanical load</b>	IK07 (2 Joule)	–	–	IK09 (10 Joule)
<b>Toxic behaviour</b>	halogen-free silicone-free	halogen-free silicone-free	halogen-free silicone-free	halogen-free silicone-free

"Halogen-free" in accordance with IEC 60754-2 "Common test methods for cables - Determination of the amount of halogen acid gas".

**For material properties see technical data.**

	<b>Boxes with terminals</b>
	<b>WP .... G, WP ... B</b>
<b>Application area</b>	Suitable for <b>outdoor installation</b> (harsh environment and/or outdoor). For application in ambient conditions with formation of condensation and ingress of water as well as for installation in the ground without traffic loads in accordance with DIN VDE V 0606-22-100.
<b>Resistant to occasional cleaning procedures</b>	<b>Resistant to cleaning procedures (direct jet)</b> <b>max. with high-pressure cleaner without additives, water temperature: max. 80° C</b>
<b>Ambient temperature</b> - Average value over 24 hours - Maximum value - Minimum value	+ 55 °C + 70 °C – 25 °C
<b>Relative humidity</b>	100%
<b>Burning behaviour</b> - Glow wire test IEC 60695-2-11 - UL Subject 94	960° C V-0 flame-retardant self-extinguishing
<b>Degree of protection against mechanical load</b>	IK08 (5 Joule)
<b>Toxic behaviour</b>	halogen-free silicone-free

Hensel cable junction boxes and cable entry systems comply with the following standards and requirements:

#### 1. Cable junction boxes

**- IEC 60670-22**

Particular requirements for connecting boxes and enclosures  
Part 22: Particular requirements for connecting boxes

**- IEC 60998**

Connecting devices for low voltage circuits for household and similar purposes  
Part 2-1: Particular requirements for connecting devices as separate entities with screw-type terminals  
Part 2-2: Particular requirements for connecting devices as separate entities with screwless-type terminals

**- IEC 60999**

**EN 60999**

Connecting devices  
Safety requirements for screw-type and screwless-type clamping units for electrical copper conductors

**- DIN VDE V 0606-22-100 (German standard)**

Enclosures for encapsulation with connection terminals (GVV)

#### 2. Cable junction boxes with terminal blocks

**- IEC 60670-22**

Particular requirements for connecting boxes and enclosures

**- EN 60947-7-1**

Low-voltage switchgear and controlgear,  
Part 7: Auxiliary equipment;  
Section 1 - Terminal blocks for copper conductors

#### 3. Conduit entries (ERA 20)

**- EN 60423**

Conduits for electrical purposes - Outside diameters of conduits for electrical installations and threads for conduits and fittings

#### 4. Degrees of protection

**- IEC 60529**

**DIN VDE 0470 Part 1 (German standard)**

Degree of protection by enclosure (IP Code)

#### 5. Halogen-free

**- EN 50267**

Examination of cables and insulated wires  
halogen-free materials

## DK Cable junction boxes

### Technical details

#### Cable junction boxes tested for intrinsic fire resistance



Junction box with connected cables after testing.

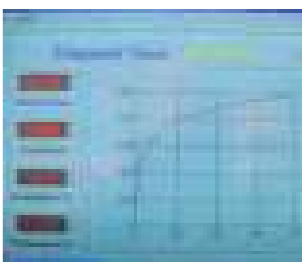

Test temperature curve in accordance with DIN 4102

Safety circuits must remain operational for a sufficient period in accordance with the national regulations governing fire protection requirements for cable installations during exposure to fire.

This ensures that electrotechnical equipment such as luminaires, lifts, smoke outlets, alarm systems etc. are supplied with power for 30 or 90 minutes and thereby enable people to leave the building and assist rescue teams in carrying out their work.

When planning and implementing these cable installations, the current specimen regulation for fire protection requirements in these installations must be observed.

**FK Cable junction boxes comply with these requirements when used together with type-approved cables as well as suitable cable clamps or mounting devices.**

- Cable junction boxes tested for intrinsic fire resistance.
- Degree of protection IP 65, IP 66
- Box made from sheet steel with powder coating or PC-GFS thermoplastics, pastel orange RAL 2003
- No additional fire load, no toxic or corrosive emissions
- Intrinsic fire resistance according to DIN 4102 part 12 (German standard) in connection with function-retaining cables of 0.5-16 mm<sup>2</sup>
- Protection against direct contact also maintained due to the box
- Captive cover with 4 screw fixings

#### Box fixing with anchors:

Anchor (building materials)	Fischer type ...					Hilti type ...		
	FIS V..	FNA..	FBS..	FBN..	FHY..	HUS..	HSA..	HIT-HY..
Limestone blocks KS 12	x					x		x
Building bricks Mz 12	x					x		x
Airbricks HLz 12	x							x
Limestone air blocks KSL 12	x							x
Prestressed concrete slabs					x			
Porous concrete slabs => 3.3						x		x
Porous concrete blocks => 4						x		x
Concrete => B25 / =< B55		x	x	x		x	x	

Please observe the current approvals and notes from the manufacturer of the anchors.

**Ambient conditions in working operation:**

Type	FK 04xx, FK 06xx, FK 16xx	FK 5000, FK 6505, FK 9xx5	FK 9259
<b>Application area</b>	Suitable for indoor installation (normal environment and/or protected outdoor)		
<b>Ambient temperature</b>			
- Average value over 24 hours	+ 35 °C	+ 35 °C	+ 35 °C
- Maximum value	+ 40 °C	+ 40 °C	+ 40 °C
- Minimum value	- 25 °C	- 25 °C	- 5 °C
<b>Relative humidity</b>			
- short-time	50 % at 40 °C 100 % at 25 °C	50 % at 40 °C 100 % at 25 °C	50 % at 40 °C 100 % at 25 °C
<b>Material</b>	PC (polycarbonate) halogen-free	sheet steel, powder-coated halogen-free	
<b>Degree of protection against mechanical load</b>	IK09 (10 Joule)	IK10 (20 Joule)	

**Standards and regulations:**

**- IEC 60998-1, DIN EN 60998 Teil 1**

Connecting devices for low-voltage circuits for household and similar purpose  
Part 1: General requirements

**- IEC 60998-2-1, DIN EN 60998 Teil 2-1**

Connecting devices for low-voltage circuits for household and similar purposes.  
Part 2-1. Particular requirements for connecting devices as separate entities with screw-type terminals

**- IEC 60670-22**

Particular requirements for connecting boxes and enclosures

**- IEC 60529, DIN VDE 0470 Teil 1 (German standard)**

Degrees of protection provided by enclosures (IP Code)

**- EN 60947-7-1**

Low-voltage switchgear and controlgear -  
Part 7-1: Auxiliary equipment - Terminal blocks for copper conductors

**- DIN EN 50262**

Metric cable glands for electrical installations

**- DIN 4102 Part 12 (German standard)**

Fire behaviour of building materials and structural elements) -  
Part 12 - Intrinsic fire resistance of electric cable systems; requirements and tests

**- EN 50200**

Method of test for resistance to fire of unprotected small cables for use in emergency circuits.



## KV Small-type distribution boards up to 63 A

- 3 to 54 modules
- degree of protection IP 54-65
- protection class II, 
- in accordance with IEC 60670-24 / DIN 43871
- colour grey, RAL 7035

Circuit breaker boxes - cable entry via integrated elastic membranes	144 - 166
Circuit breaker boxes - cable entry via metric knockouts	167 - 185
Circuit breaker boxes - "weatherproof", for outdoor installation	186 - 191
Circuit breaker boxes - conduit entry via integrated elastic membranes	192 - 195
Circuit breaker boxes with additional space for electrical devices not to be manually actuated	
- cable entry via integrated elastic membranes	196 - 199
- cable entry via metric knockouts	200 - 203
Circuit breaker boxes - with flanges for individual drilling of cable entries	204 - 206
Empty boxes	207 - 208
KWH Meter boxes	209 - 210
Accessories	211 - 215
Technical details	216 - 223

Further technical information can be found on the Internet  
[www.hensel-electric.de](http://www.hensel-electric.de) -> Products

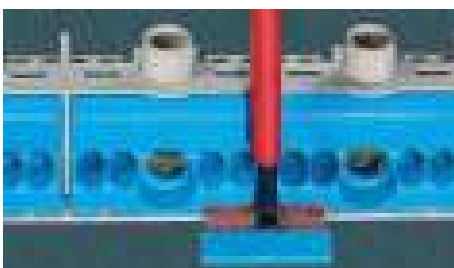
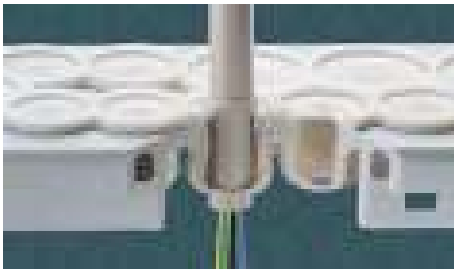

### KV small-type distribution boards

#### Circuit breaker box

#### Cable entry via integrated elastic membranes

- Compact user friendly solution, optically optimized by cable entry cover
- Integrated compartment for accessories - everything has its proper place
- DIN-rails with stopper for proper position of installation device
- Screws made of stainless steel V2A
- FIXCONNECT® plug-in terminal technology for PE and N
- Connection for copper conductors
- KV Small-type distribution boards with up to four disconnectable N-potentials in one bar enable the installation of RCDs without additional efforts or accessories
- 12 to 54 modules: attached blanking strips for DIN rail equipment openings
- 3 to 9 modules: protective cover can be cut out
- Material: polystyrene
- Burning behaviour: glow wire test in accordance with IEC 60695-2-11: 750 °C, flame-retardant, self-extinguishing
- Colour: grey, RAL 7035

**KV small-type distribution boards**  
**Circuit breaker boxes**  
**Cable entry via integrated elastic membranes**



**KV 9103**  
**3 modules: 1 x 3 x 18 mm**

- 1-row
- per PE/N number x cross section 1 x 25 mm<sup>2</sup>, 4 x 4 mm<sup>2</sup> Cu, FIXCONNECT® terminal technology, for terminal technology refer to technical data
- for the installation of DIN rail equipment, top hat profile 35 mm
- with transparent lid, sealable
- locking device for hinged lid and sealing facility see accessories
- with cable entry cover
- protective cover can be cut out
- cable entry via integrated elastic membranes

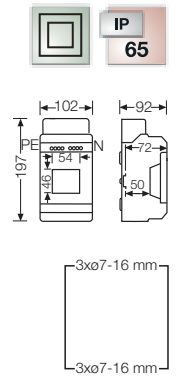

rated insulation voltage	$U_i = 400 \text{ V a.c.}$
power dissipation capability	$P_{de} = 10 \text{ watts}$ according to EN 60670-24



**KV 8103**  
**3 modules: 1 x 3 x 18 mm**  
**without PE and N terminal**

- 1-row
- order PE/N terminals separately
- for the installation of DIN rail equipment, top hat profile 35 mm
- with transparent lid, sealable
- locking device for hinged lid and sealing facility see accessories
- with cable entry cover
- protective cover can be cut out
- cable entry via integrated elastic membranes

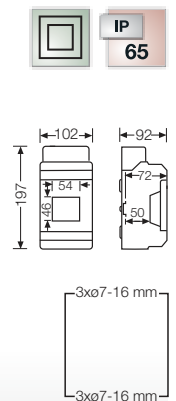

rated insulation voltage	$U_i = 400 \text{ V a.c.}$
power dissipation capability	$P_{de} = 10 \text{ watts}$ according to EN 60670-24



**KV 1503**  
**3 modules: 1 x 3 x 18 mm**

- 1-row
- per PE/N number x cross section 1 x 25 mm<sup>2</sup>, 4 x 4 mm<sup>2</sup> Cu, FIXCONNECT® terminal technology, for terminal technology refer to technical data
- for the installation of DIN rail equipment, top hat profile 35 mm
- with transparent lid, sealable
- locking device for hinged lid and sealing facility see accessories
- with cable entry cover
- protective cover can be cut out
- cable entry via integrated elastic membranes

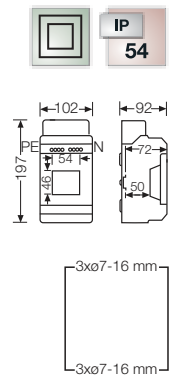

rated insulation voltage	$U_i = 400 \text{ V a.c.}$
power dissipation capability	$P_{de} = 10 \text{ watts}$ according to EN 60670-24

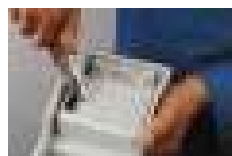

3 to 9 modules: protective cover can be cut out



British Standard installation with earthed armoured cables



**KV 1603**

**3 modules: 1 x 3 x 18 mm**  
**without PE and N terminal**

- 1-row
- order PE/N terminals separately
- for the installation of DIN rail equipment, top hat profile 35 mm
- with transparent lid, sealable
- locking device for hinged lid and sealing facility see accessories
- with cable entry cover
- protective cover can be cut out
- cable entry via integrated elastic membranes

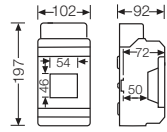

rated insulation voltage	$U_i = 400 \text{ V a.c.}$
power dissipation capability	$P_{de} = 10 \text{ watts}$ according to EN 60670-24

**KV small-type distribution boards**  
**Circuit breaker boxes**  
**Cable entry via integrated elastic membranes**



**KV 9104**

**4.5 modules: 1 x 4.5 x 18 mm**

- 1-row
- per PE/N number x cross section 2 x 25 mm<sup>2</sup>, 4 x 4 mm<sup>2</sup> Cu, FIXCONNECT® terminal technology, for terminal technology refer to technical data
- for the installation of DIN rail equipment, top hat profile 35 mm
- with transparent lid, sealable
- locking device for hinged lid and sealing facility see accessories
- with cable entry cover
- protective cover can be cut out
- cable entry via integrated elastic membranes

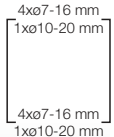
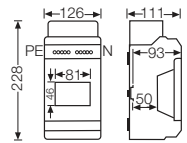

rated insulation voltage	$U_i = 400 \text{ V a.c.}$
power dissipation capability	$P_{de} = 12 \text{ watts}$ according to EN 60670-24



**KV 8104**

**4.5 modules: 1 x 4.5 x 18 mm**  
**without PE and N terminal**

- 1-row
- order PE/N terminals separately
- for the installation of DIN rail equipment, top hat profile 35 mm
- with transparent lid, sealable
- locking device for hinged lid and sealing facility see accessories
- with cable entry cover
- protective cover can be cut out
- cable entry via integrated elastic membranes

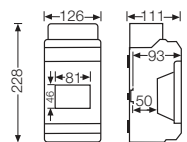

rated insulation voltage	$U_i = 400 \text{ V a.c.}$
power dissipation capability	$P_{de} = 12 \text{ watts}$ according to EN 60670-24



**KV 1504**

**4.5 modules: 1 x 4.5 x 18 mm**

- 1-row
- per PE/N number x cross section 2 x 25 mm<sup>2</sup>, 4 x 4 mm<sup>2</sup> Cu, FIXCONNECT® terminal technology, for terminal technology refer to technical data
- for the installation of DIN rail equipment, top hat profile 35 mm
- with transparent lid, sealable
- locking device for hinged lid and sealing facility see accessories
- with cable entry cover
- protective cover can be cut out
- cable entry via integrated elastic membranes

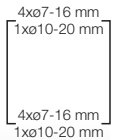
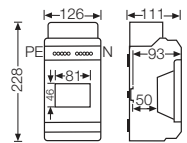

rated insulation voltage	$U_i = 400 \text{ V a.c.}$
power dissipation capability	$P_{de} = 12 \text{ watts}$ according to EN 60670-24

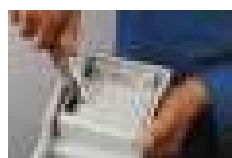

3 to 9 modules: protective cover can be cut out



British Standard installation with earthed armoured cables



**KV 1604**

**4.5 modules: 1 x 4.5 x 18 mm**  
**without PE and N terminal**

- 1-row
- order PE/N terminals separately
- for the installation of DIN rail equipment, top hat profile 35 mm
- with transparent lid, sealable
- locking device for hinged lid and sealing facility see accessories
- with cable entry cover
- protective cover can be cut out
- cable entry via integrated elastic membranes

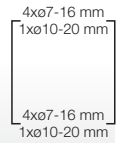
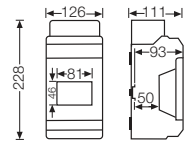

rated insulation voltage	$U_i = 400 \text{ V a.c.}$
power dissipation capability	$P_{de} = 12 \text{ watts}$ according to EN 60670-24

**KV small-type distribution boards**  
**Circuit breaker boxes**  
**Cable entry via integrated elastic membranes**



**KV 9106**  
**6 modules: 1 x 6 x 18 mm**

- 1-row
- per PE/N number x cross section 2 x 25 mm<sup>2</sup>, 4 x 4 mm<sup>2</sup> Cu, FIXCONNECT® terminal technology, for terminal technology refer to technical data
- for the installation of DIN rail equipment, top hat profile 35 mm
- with transparent lid, sealable
- locking device for hinged lid and sealing facility see accessories
- with cable entry cover
- protective cover can be cut out
- cable entry via integrated elastic membranes

rated insulation voltage	$U_i = 400 \text{ V a.c.}$
power dissipation capability	$P_{de} = 13 \text{ watts}$ according to EN 60670-24

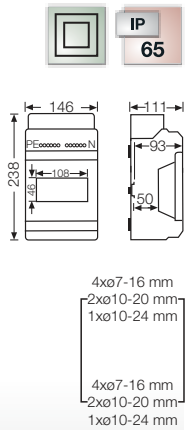

**KV 8106**  
**6 modules: 1 x 6 x 18 mm**  
**without PE and N terminal**

- 1-row
- order PE/N terminals separately
- for the installation of DIN rail equipment, top hat profile 35 mm
- with transparent lid, sealable
- locking device for hinged lid and sealing facility see accessories
- with cable entry cover
- protective cover can be cut out
- cable entry via integrated elastic membranes

rated insulation voltage	$U_i = 400 \text{ V a.c.}$
power dissipation capability	$P_{de} = 13 \text{ watts}$ according to EN 60670-24

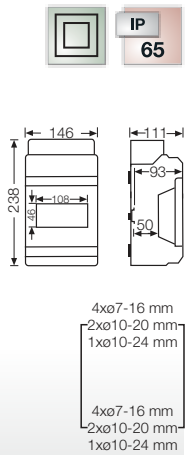

**KV 1506**  
**6 modules: 1 x 6 x 18 mm**

- 1-row
- per PE/N number x cross section 2 x 25 mm<sup>2</sup>, 4 x 4 mm<sup>2</sup> Cu, FIXCONNECT® terminal technology, for terminal technology refer to technical data
- for the installation of DIN rail equipment, top hat profile 35 mm
- with transparent lid, sealable
- locking device for hinged lid and sealing facility see accessories
- with cable entry cover
- protective cover can be cut out
- cable entry via integrated elastic membranes

rated insulation voltage	$U_i = 400 \text{ V a.c.}$
power dissipation capability	$P_{de} = 13 \text{ watts}$ according to EN 60670-24

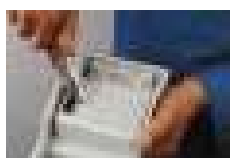
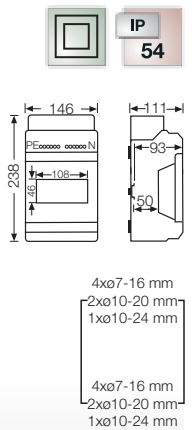

3 to 9 modules: protective cover can be cut out



British Standard installation with earthed armored cables



**KV 1606**

**6 modules: 1 x 6 x 18 mm**  
**without PE and N terminal**

- 1-row
- order PE/N terminals separately
- for the installation of DIN rail equipment, top hat profile 35 mm
- with transparent lid, sealable
- locking device for hinged lid and sealing facility see accessories
- with cable entry cover
- protective cover can be cut out
- cable entry via integrated elastic membranes

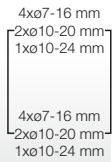
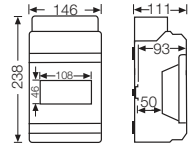

rated insulation voltage	$U_i = 400 \text{ V a.c.}$
power dissipation capability	$P_{de} = 13 \text{ watts}$ according to EN 60670-24

**KV small-type distribution boards**  
**Circuit breaker boxes**  
**Cable entry via integrated elastic membranes**



**KV 9109**  
**9 modules: 1 x 9 x 18 mm**

- 1-row
- per PE/N number x cross section 2 x 25 mm<sup>2</sup>, 8 x 4 mm<sup>2</sup> Cu, FIXCONNECT® terminal technology, for terminal technology refer to technical data
- for the installation of DIN rail equipment, top hat profile 35 mm
- with transparent lid, sealable
- locking device for hinged lid and sealing facility see accessories
- with cable entry cover
- protective cover can be cut out
- cable entry via integrated elastic membranes

rated insulation voltage	$U_i = 400 \text{ V a.c.}$
power dissipation capability	$P_{de} = 16 \text{ watts}$ according to EN 60670-24

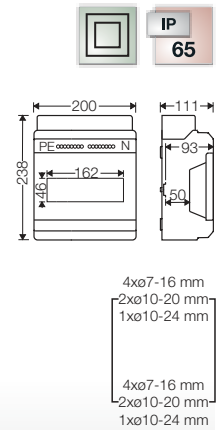

**KV 8109**  
**9 modules: 1 x 9 x 18 mm**  
**without PE and N terminal**

- 1-row
- order PE/N terminals separately
- for the installation of DIN rail equipment, top hat profile 35 mm
- with transparent lid, sealable
- locking device for hinged lid and sealing facility see accessories
- with cable entry cover
- protective cover can be cut out
- cable entry via integrated elastic membranes

rated insulation voltage	$U_i = 400 \text{ V a.c.}$
power dissipation capability	$P_{de} = 16 \text{ watts}$ according to EN 60670-24

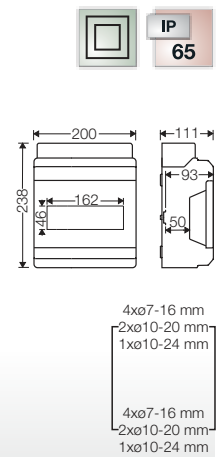

**KV 1509**  
**9 modules: 1 x 9 x 18 mm**

- 1-row
- per PE/N number x cross section 2 x 25 mm<sup>2</sup>, 8 x 4 mm<sup>2</sup> Cu, FIXCONNECT® terminal technology, for terminal technology refer to technical data
- for the installation of DIN rail equipment, top hat profile 35 mm
- with transparent lid, sealable
- locking device for hinged lid and sealing facility see accessories
- with cable entry cover
- protective cover can be cut out
- cable entry via integrated elastic membranes

rated insulation voltage	$U_i = 400 \text{ V a.c.}$
power dissipation capability	$P_{de} = 16 \text{ watts}$ according to EN 60670-24

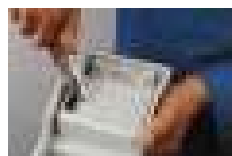
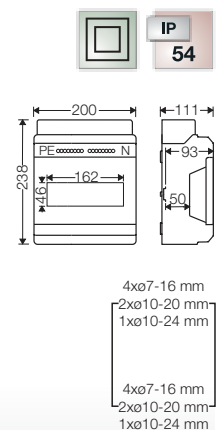

3 to 9 modules: protective cover can be cut out



British Standard installation with earthed armoured cables



**KV 1609**

**9 modules: 1 x 9 x 18 mm**  
**without PE and N terminal**

- 1-row
- order PE/N terminals separately
- for the installation of DIN rail equipment, top hat profile 35 mm
- with transparent lid, sealable
- locking device for hinged lid and sealing facility see accessories
- with cable entry cover
- protective cover can be cut out
- cable entry via integrated elastic membranes

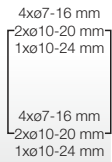
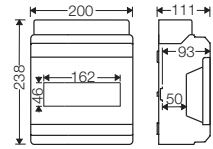

rated insulation voltage	$U_i = 400 \text{ V a.c.}$
power dissipation capability	$P_{de} = 16 \text{ watts}$ according to EN 60670-24

**KV small-type distribution boards**  
**Circuit breaker boxes**  
**Cable entry via integrated elastic membranes**



**KV 9112**

**12 modules: 1 x 12 x 18 mm**

- 1-row
- per PE/N number x cross section 3 x 25 mm<sup>2</sup>, 12 x 4 mm<sup>2</sup> Cu, FIXCONNECT® terminal technology, for terminal technology refer to technical data
- N separable, for up to 2 different potentials
- for the installation of DIN rail equipment, top hat profile 35 mm
- with transparent door
- for door locking device and sealing device refer to accessories
- with cable entry cover
- with blanking strips for unused DIN rail openings
- cable entry via integrated elastic membranes

rated insulation voltage	$U_i = 400 \text{ V a.c.}$
power dissipation capability	$P_{de} = 26 \text{ watts}$ according to EN 60670-24
permissible power dissipation	$P_{zul} = 21 \text{ watts at } 30 \text{ K}$ according to DIN 43871

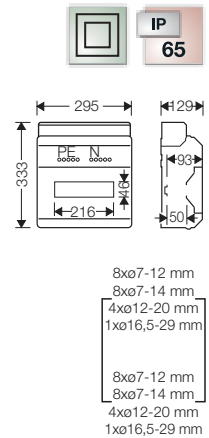

**KV 8112**

**12 modules: 1 x 12 x 18 mm**  
**without PE and N terminal**

- 1-row
- order PE/N terminals separately
- for the installation of DIN rail equipment, top hat profile 35 mm
- with transparent door
- for door locking device and sealing device refer to accessories
- with cable entry cover
- with blanking strips for unused DIN rail openings
- cable entry via integrated elastic membranes

rated insulation voltage	$U_i = 400 \text{ V a.c.}$
power dissipation capability	$P_{de} = 26 \text{ watts}$ according to EN 60670-24
permissible power dissipation	$P_{zul} = 21 \text{ watts at } 30 \text{ K}$ according to DIN 43871

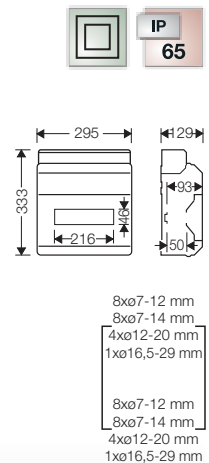

Variable installation depth by mounting DIN-rails in different levels



Included blanking strips



**KV 1512**

**12 modules: 1 x 12 x 18 mm**

- 1-row
- per PE/N number x cross section 3 x 25 mm<sup>2</sup>, 12 x 4 mm<sup>2</sup> Cu, FIXCONNECT® terminal technology, for terminal technology refer to technical data
- N separable, for up to 2 different potentials
- for the installation of DIN rail equipment, top hat profile 35 mm
- with transparent door
- for door locking device and sealing device refer to accessories
- with cable entry cover
- with blanking strips for unused DIN rail openings
- cable entry via integrated elastic membranes

rated insulation voltage	$U_i = 400 \text{ V a.c.}$
power dissipation capability	$P_{de} = 26 \text{ watts}$ according to EN 60670-24
permissible power dissipation	$P_{zul} = 21 \text{ watts at } 30 \text{ K}$ according to DIN 43871

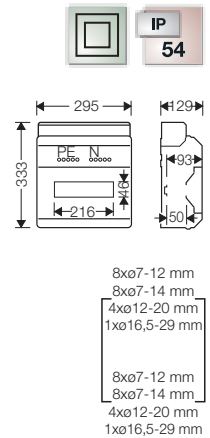

**KV 1612**

**12 modules: 1 x 12 x 18 mm**  
**without PE and N terminal**

- 1-row
- order PE/N terminals separately
- for the installation of DIN rail equipment, top hat profile 35 mm
- with transparent door
- for door locking device and sealing device refer to accessories
- with cable entry cover
- with blanking strips for unused DIN rail openings
- cable entry via integrated elastic membranes

rated insulation voltage	$U_i = 400 \text{ V a.c.}$
power dissipation capability	$P_{de} = 26 \text{ watts}$ according to EN 60670-24
permissible power dissipation	$P_{zul} = 21 \text{ watts at } 30 \text{ K}$ according to DIN 43871

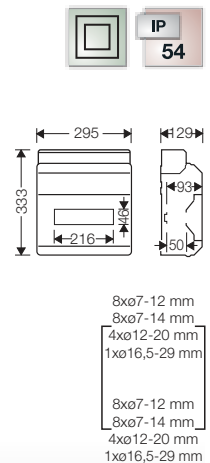

**KV small-type distribution boards**  
**Circuit breaker boxes**  
**Cable entry via integrated elastic membranes**



**KV 9118**

**18 modules: 1 x 18 x 18 mm**

- 1-row
- per PE/N number x cross section 4 x 25 mm<sup>2</sup>, 16 x 4 mm<sup>2</sup> Cu, FIXCONNECT® terminal technology, for terminal technology refer to technical data
- N separable, for up to 2 different potentials
- for the installation of DIN rail equipment, top hat profile 35 mm
- with transparent door
- for door locking device and sealing device refer to accessories
- with cable entry cover
- with blanking strips for unused DIN rail openings
- cable entry via integrated elastic membranes

rated insulation voltage	$U_i = 400 \text{ V a.c.}$
power dissipation capability	$P_{de} = 33 \text{ watts}$ according to EN 60670-24

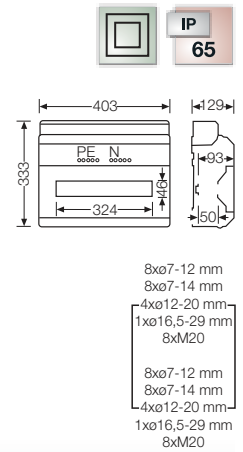

**KV 8118**

**18 modules: 1 x 18 x 18 mm**  
**without PE and N terminal**

- 1-row
- order PE/N terminals separately
- for the installation of DIN rail equipment, top hat profile 35 mm
- with transparent door
- for door locking device and sealing device refer to accessories
- with cable entry cover
- with blanking strips for unused DIN rail openings
- cable entry via integrated elastic membranes

rated insulation voltage	$U_i = 400 \text{ V a.c.}$
power dissipation capability	$P_{de} = 33 \text{ watts}$ according to EN 60670-24

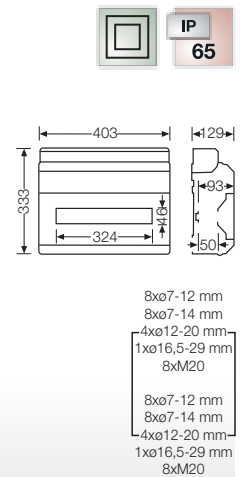

Variable installation depth by mounting DIN-rails in different levels



Included blanking strips

**KV small-type distribution boards**  
**Circuit breaker boxes**  
**Cable entry via integrated elastic membranes**



**KV 1518**

**18 modules: 1 x 18 x 18 mm**

- 1-row
- per PE/N number x cross section 4 x 25 mm<sup>2</sup>, 16 x 4 mm<sup>2</sup> Cu, FIXCONNECT® terminal technology, for terminal technology refer to technical data
- N separable, for up to 2 different potentials
- for the installation of DIN rail equipment, top hat profile 35 mm
- with transparent door
- for door locking device and sealing device refer to accessories
- with cable entry cover
- with blanking strips for unused DIN rail openings
- cable entry via integrated elastic membranes

rated insulation voltage	$U_i = 400 \text{ V a.c.}$
power dissipation capability	$P_{de} = 33 \text{ watts}$ according to EN 60670-24

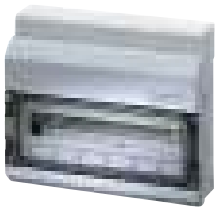
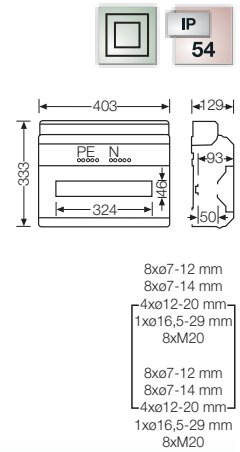

**KV 1618**

**18 modules: 1 x 18 x 18 mm**  
**without PE and N terminal**

- 1-row
- order PE/N terminals separately
- for the installation of DIN rail equipment, top hat profile 35 mm
- with transparent door
- for door locking device and sealing device refer to accessories
- with cable entry cover
- with blanking strips for unused DIN rail openings
- cable entry via integrated elastic membranes

rated insulation voltage	$U_i = 400 \text{ V a.c.}$
power dissipation capability	$P_{de} = 33 \text{ watts}$ according to EN 60670-24

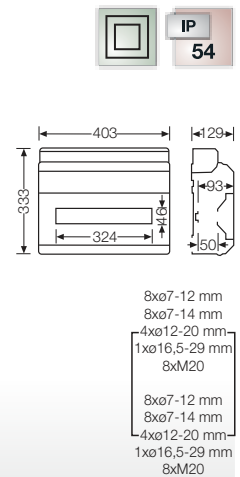

**KV small-type distribution boards**  
**Circuit breaker boxes**  
**Cable entry via integrated elastic membranes**

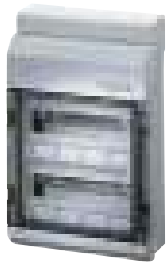

**KV 9224**

**24 modules: 2 x 12 x 18 mm**

- 2-row
- per PE/N number x cross section 6 x 25 mm<sup>2</sup>, 24 x 4 mm<sup>2</sup> Cu, FIXCONNECT® terminal technology, for terminal technology refer to technical data
- N separable, up to 4 different potentials
- for the installation of DIN rail equipment, top hat profile 35 mm
- with transparent door
- for door locking device and sealing device refer to accessories
- with cable entry cover
- with blanking strips for unused DIN rail openings
- cable entry via integrated elastic membranes

rated insulation voltage	$U_i = 400 \text{ V a.c.}$
power dissipation capability	$P_{de} = 31 \text{ watts}$ according to EN 60670-24
permissible power dissipation	$P_{zul} = 25 \text{ watts at } 30 \text{ K}$ according to DIN 43871

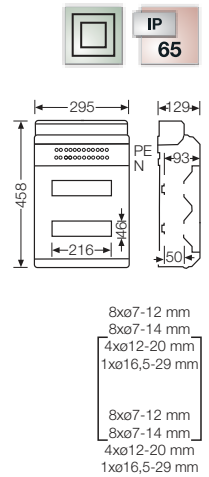

**KV 8224**

**24 modules: 2 x 12 x 18 mm**  
**without PE and N terminal**

- 2-row
- order PE/N terminals separately
- for the installation of DIN rail equipment, top hat profile 35 mm
- with transparent door
- for door locking device and sealing device refer to accessories
- with cable entry cover
- with blanking strips for unused DIN rail openings
- cable entry via integrated elastic membranes

rated insulation voltage	$U_i = 400 \text{ V a.c.}$
power dissipation capability	$P_{de} = 31 \text{ watts}$ according to EN 60670-24
permissible power dissipation	$P_{zul} = 25 \text{ watts at } 30 \text{ K}$ according to DIN 43871

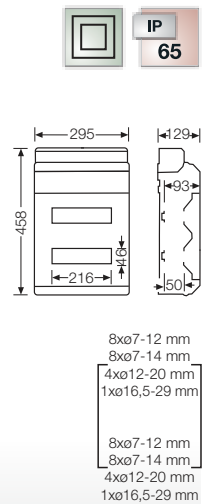

Variable installation depth by mounting DIN-rails in different levels



Included blanking strips

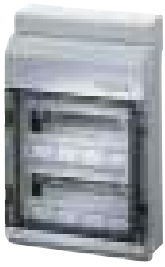

**KV 2524**

**24 modules: 2 x 12 x 18 mm**

- 2-row
- per PE/N number x cross section 6 x 25 mm<sup>2</sup>, 24 x 4 mm<sup>2</sup> Cu, FIXCONNECT® terminal technology, for terminal technology refer to technical data
- N separable, up to 4 different potentials
- for the installation of DIN rail equipment, top hat profile 35 mm
- with transparent door
- for door locking device and sealing device refer to accessories
- with cable entry cover
- with blanking strips for unused DIN rail openings
- cable entry via integrated elastic membranes

rated insulation voltage	$U_i = 400 \text{ V a.c.}$
power dissipation capability	$P_{de} = 31 \text{ watts}$ according to EN 60670-24
permissible power dissipation	$P_{zul} = 25 \text{ watts at } 30 \text{ K}$ according to DIN 43871

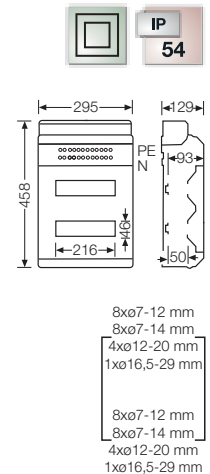

**KV 2624**

**24 modules: 2 x 12 x 18 mm**  
**without PE and N terminal**

- 2-row
- order PE/N terminals separately
- for the installation of DIN rail equipment, top hat profile 35 mm
- with transparent door
- for door locking device and sealing device refer to accessories
- with cable entry cover
- with blanking strips for unused DIN rail openings
- cable entry via integrated elastic membranes

rated insulation voltage	$U_i = 400 \text{ V a.c.}$
power dissipation capability	$P_{de} = 31 \text{ watts}$ according to EN 60670-24
permissible power dissipation	$P_{zul} = 25 \text{ watts at } 30 \text{ K}$ according to DIN 43871

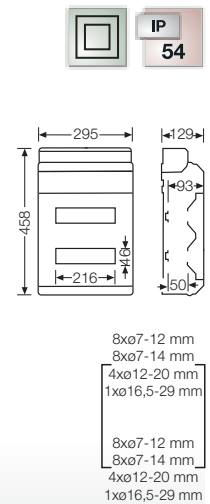

**KV small-type distribution boards**  
**Circuit breaker boxes**  
**Cable entry via integrated elastic membranes**



**KV 9236**  
**36 modules: 2 x 18 x 18 mm**

- 2-row
- per PE/N number x cross section 8 x 25 mm<sup>2</sup>, 32 x 4 mm<sup>2</sup> Cu, FIXCONNECT® terminal technology, for terminal technology refer to technical data
- N separable, up to 4 different potentials
- for the installation of DIN rail equipment, top hat profile 35 mm
- with transparent door
- for door locking device and sealing device refer to accessories
- with cable entry cover
- with blanking strips for unused DIN rail openings
- cable entry via integrated elastic membranes

rated insulation voltage	$U_i = 400 \text{ V a.c.}$
power dissipation capability	$P_{de} = 38 \text{ watts}$ according to EN 60670-24

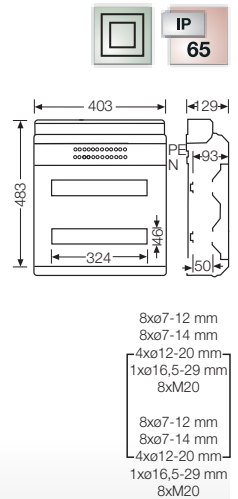

**KV 8236**  
**36 modules: 2 x 18 x 18 mm**  
**without PE and N terminal**

- 2-row
- order PE/N terminals separately
- for the installation of DIN rail equipment, top hat profile 35 mm
- with transparent door
- for door locking device and sealing device refer to accessories
- with cable entry cover
- with blanking strips for unused DIN rail openings
- cable entry via integrated elastic membranes

rated insulation voltage	$U_i = 400 \text{ V a.c.}$
power dissipation capability	$P_{de} = 38 \text{ watts}$ according to EN 60670-24

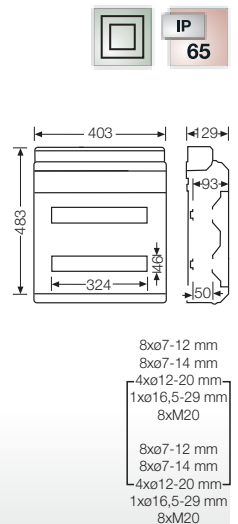

Variable installation depth by mounting DIN-rails in different levels



Included blanking strips

**KV small-type distribution boards**  
**Circuit breaker boxes**  
**Cable entry via integrated elastic membranes**



**KV 2536**

**36 modules: 2 x 18 x 18 mm**

- 2-row
- per PE/N number x cross section 8 x 25 mm<sup>2</sup>, 32 x 4 mm<sup>2</sup> Cu, FIXCONNECT® terminal technology, for terminal technology refer to technical data
- N separable, up to 4 different potentials
- for the installation of DIN rail equipment, top hat profile 35 mm
- with transparent door
- for door locking device and sealing device refer to accessories
- with cable entry cover
- with blanking strips for unused DIN rail openings
- cable entry via integrated elastic membranes

rated insulation voltage	$U_i = 400 \text{ V a.c.}$
power dissipation capability	$P_{de} = 38 \text{ watts}$ according to EN 60670-24

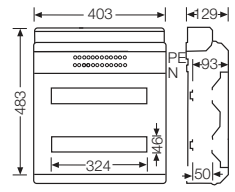

- 8xØ7-12 mm
- 8xØ7-14 mm
- 4xØ12-20 mm
- 1xØ16,5-29 mm
- 8xM20
- 8xØ7-12 mm
- 8xØ7-14 mm
- 4xØ12-20 mm
- 1xØ16,5-29 mm
- 8xM20



**KV 2636**

**36 modules: 2 x 18 x 18 mm**  
**without PE and N terminal**

- 2-row
- order PE/N terminals separately
- for the installation of DIN rail equipment, top hat profile 35 mm
- with transparent door
- for door locking device and sealing device refer to accessories
- with cable entry cover
- with blanking strips for unused DIN rail openings
- cable entry via integrated elastic membranes

rated insulation voltage	$U_i = 400 \text{ V a.c.}$
power dissipation capability	$P_{de} = 38 \text{ watts}$ according to EN 60670-24

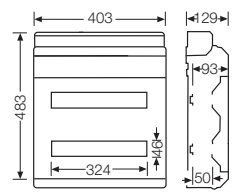

- 8xØ7-12 mm
- 8xØ7-14 mm
- 4xØ12-20 mm
- 1xØ16,5-29 mm
- 8xM20
- 8xØ7-12 mm
- 8xØ7-14 mm
- 4xØ12-20 mm
- 1xØ16,5-29 mm
- 8xM20

**KV small-type distribution boards**  
**Circuit breaker boxes**  
**Cable entry via integrated elastic membranes**



**KV 9336**

**36 modules: 3 x 12 x 18 mm**

- 3-row
- per PE/N number x cross section 6 x 25 mm<sup>2</sup>, 24 x 4 mm<sup>2</sup> Cu, FIXCONNECT® terminal technology, for terminal technology refer to technical data
- N separable, up to 4 different potentials
- for the installation of DIN rail equipment, top hat profile 35 mm
- with transparent door
- for door locking device and sealing device refer to accessories
- with cable entry cover
- with blanking strips for unused DIN rail openings
- cable entry via integrated elastic membranes

rated insulation voltage	$U_i = 400 \text{ V a.c.}$
power dissipation capability	$P_{de} = 35 \text{ watts}$ according to EN 60670-24
permissible power dissipation	$P_{zul} = 28 \text{ watts at } 30 \text{ K}$ according to DIN 43871

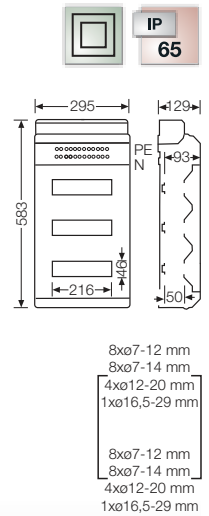

**KV 8336**

**36 modules: 3 x 12 x 18 mm**  
**without PE and N terminal**

- 3-row
- order PE/N terminals separately
- for the installation of DIN rail equipment, top hat profile 35 mm
- with transparent door
- for door locking device and sealing device refer to accessories
- with cable entry cover
- with blanking strips for unused DIN rail openings
- cable entry via integrated elastic membranes

rated insulation voltage	$U_i = 400 \text{ V a.c.}$
power dissipation capability	$P_{de} = 35 \text{ watts}$ according to EN 60670-24
permissible power dissipation	$P_{zul} = 28 \text{ watts at } 30 \text{ K}$ according to DIN 43871

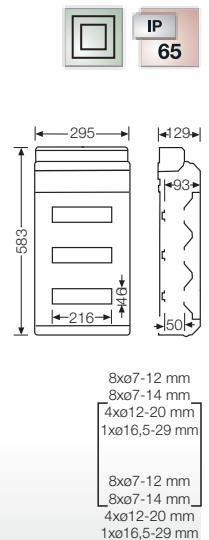

Variable installation depth by mounting DIN-rails in different levels



Included blanking strips

**KV small-type distribution boards**  
**Circuit breaker boxes**  
**Cable entry via integrated elastic membranes**



**KV 3536**  
**36 modules: 3 x 12 x 18 mm**

- 3-row
- per PE/N number x cross section 6 x 25 mm<sup>2</sup>, 24 x 4 mm<sup>2</sup> Cu, FIXCONNECT® terminal technology, for terminal technology refer to technical data
- N separable, up to 4 different potentials
- for the installation of DIN rail equipment, top hat profile 35 mm
- with transparent door
- for door locking device and sealing device refer to accessories
- with cable entry cover
- with blanking strips for unused DIN rail openings
- cable entry via integrated elastic membranes

rated insulation voltage	$U_i = 400 \text{ V a.c.}$
power dissipation capability	$P_{de} = 35 \text{ watts}$ according to EN 60670-24
permissible power dissipation	$P_{zul} = 28 \text{ watts at } 30 \text{ K}$ according to DIN 43871

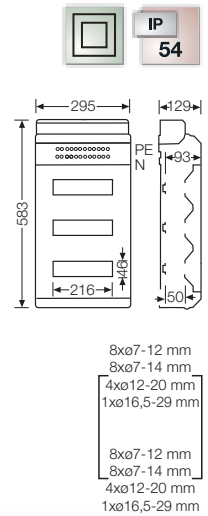

**KV 3636**  
**36 modules: 3 x 12 x 18 mm**  
**without PE and N terminal**

- 3-row
- order PE/N terminals separately
- for the installation of DIN rail equipment, top hat profile 35 mm
- with transparent door
- for door locking device and sealing device refer to accessories
- with cable entry cover
- with blanking strips for unused DIN rail openings
- cable entry via integrated elastic membranes

rated insulation voltage	$U_i = 400 \text{ V a.c.}$
power dissipation capability	$P_{de} = 35 \text{ watts}$ according to EN 60670-24
permissible power dissipation	$P_{zul} = 28 \text{ watts at } 30 \text{ K}$ according to DIN 43871

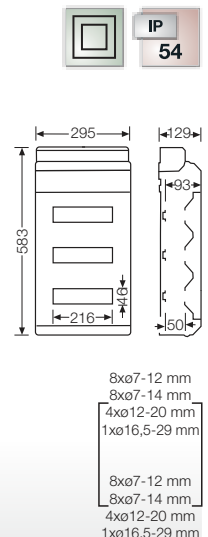

**KV small-type distribution boards**  
**Circuit breaker boxes**  
**Cable entry via integrated elastic membranes**



**KV 9448**

**48 modules: 4 x 12 x 18 mm**

- 4-row
- per PE/N number x cross section 6 x 25 mm<sup>2</sup>, 24 x 4 mm<sup>2</sup> Cu, FIXCONNECT® terminal technology, for terminal technology refer to technical data
- N separable, up to 4 different potentials
- for the installation of DIN rail equipment, top hat profile 35 mm
- with transparent door
- for door locking device and sealing device refer to accessories
- with cable entry cover
- with blanking strips for unused DIN rail openings
- cable entry via integrated elastic membranes

rated insulation voltage	$U_i = 400 \text{ V a.c.}$
power dissipation capability	$P_{de} = 43 \text{ watts}$ according to EN 60670-24
permissible power dissipation	$P_{zul} = 34 \text{ watts at } 30 \text{ K}$ according to DIN 43871

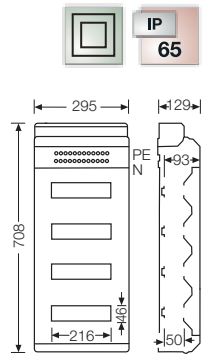

8xø7-12 mm  
 8xø7-14 mm  
 4xø12-20 mm  
 1xø16,5-29 mm

8xø7-12 mm  
 8xø7-14 mm  
 4xø12-20 mm  
 1xø16,5-29 mm



**KV 8448**

**48 modules: 4 x 12 x 18 mm**  
**without PE and N terminal**

- 4-row
- order PE/N terminals separately
- for the installation of DIN rail equipment, top hat profile 35 mm
- with transparent door
- for door locking device and sealing device refer to accessories
- with cable entry cover
- with blanking strips for unused DIN rail openings
- cable entry via integrated elastic membranes

rated insulation voltage	$U_i = 400 \text{ V a.c.}$
power dissipation capability	$P_{de} = 43 \text{ watts}$ according to EN 60670-24
permissible power dissipation	$P_{zul} = 34 \text{ watts at } 30 \text{ K}$ according to DIN 43871

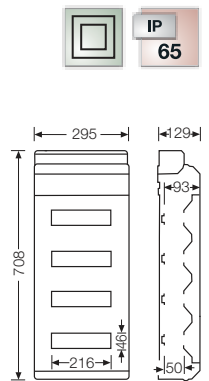

8xø7-12 mm  
 8xø7-14 mm  
 4xø12-20 mm  
 1xø16,5-29 mm

8xø7-12 mm  
 8xø7-14 mm  
 4xø12-20 mm  
 1xø16,5-29 mm



Variable installation depth by mounting DIN-rails in different levels



Included blanking strips

**KV small-type distribution boards**  
**Circuit breaker boxes**  
**Cable entry via integrated elastic membranes**



**KV 4548**

**48 modules: 4 x 12 x 18 mm**

- 4-row
- per PE/N number x cross section 6 x 25 mm<sup>2</sup>, 24 x 4 mm<sup>2</sup> Cu, FIXCONNECT® terminal technology, for terminal technology refer to technical data
- N separable, up to 4 different potentials
- for the installation of DIN rail equipment, top hat profile 35 mm
- with transparent door
- for door locking device and sealing device refer to accessories
- with cable entry cover
- with blanking strips for unused DIN rail openings
- cable entry via integrated elastic membranes

rated insulation voltage	$U_i = 400 \text{ V a.c.}$
power dissipation capability	$P_{de} = 43 \text{ watts}$ according to EN 60670-24
permissible power dissipation	$P_{zul} = 34 \text{ watts at } 30 \text{ K}$ according to DIN 43871

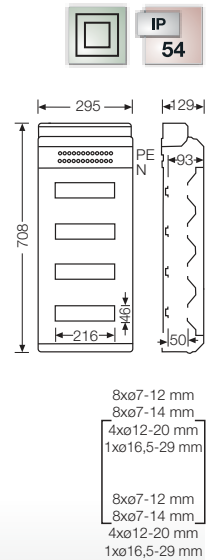

**KV 4648**

**48 modules: 4 x 12 x 18 mm**  
**without PE and N terminal**

- 4-row
- order PE/N terminals separately
- for the installation of DIN rail equipment, top hat profile 35 mm
- with transparent door
- for door locking device and sealing device refer to accessories
- with cable entry cover
- with blanking strips for unused DIN rail openings
- cable entry via integrated elastic membranes

rated insulation voltage	$U_i = 400 \text{ V a.c.}$
power dissipation capability	$P_{de} = 43 \text{ watts}$ according to EN 60670-24
permissible power dissipation	$P_{zul} = 34 \text{ watts at } 30 \text{ K}$ according to DIN 43871

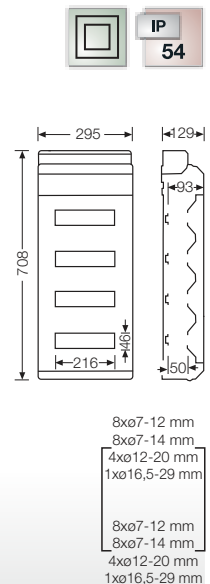

**KV small-type distribution boards**  
**Circuit breaker boxes**  
**Cable entry via integrated elastic membranes**



**KV 9354**

**54 modules: 3 x 18 x 18 mm**

- 3-row
- per PE/N number x cross section 8 x 25 mm<sup>2</sup>, 32 x 4 mm<sup>2</sup> Cu, FIXCONNECT® terminal technology, for terminal technology refer to technical data
- N separable, up to 4 different potentials
- for the installation of DIN rail equipment, top hat profile 35 mm
- with transparent door
- for door locking device and sealing device refer to accessories
- with cable entry cover
- with blanking strips for unused DIN rail openings
- cable entry via integrated elastic membranes

rated insulation voltage	$U_i = 400 \text{ V a.c.}$
power dissipation capability	$P_{de} = 50 \text{ watts}$ according to EN 60670-24

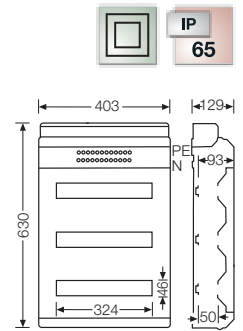

- 8xø7-12 mm
- 8xø7-14 mm
- 4xø12-20 mm
- 1xø16,5-29 mm
- 8xM20



**KV 8354**

**54 modules: 3 x 18 x 18 mm**  
**without PE and N terminal**

- 3-row
- order PE/N terminals separately
- for the installation of DIN rail equipment, top hat profile 35 mm
- with transparent door
- for door locking device and sealing device refer to accessories
- with cable entry cover
- with blanking strips for unused DIN rail openings
- cable entry via integrated elastic membranes

rated insulation voltage	$U_i = 400 \text{ V a.c.}$
power dissipation capability	$P_{de} = 50 \text{ watts}$ according to EN 60670-24

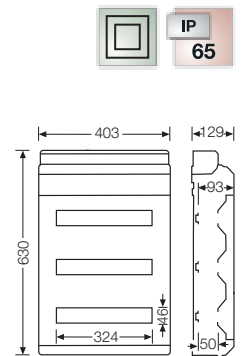

- 8xø7-12 mm
- 8xø7-14 mm
- 4xø12-20 mm
- 1xø16,5-29 mm
- 8xM20



Variable installation depth by mounting DIN-rails in different levels



Included blanking strips

**KV small-type distribution boards**  
**Circuit breaker boxes**  
**Cable entry via integrated elastic membranes**



**KV 3554**

**54 modules: 3 x 18 x 18 mm**

- 3-row
- per PE/N number x cross section 8 x 25 mm<sup>2</sup>, 32 x 4 mm<sup>2</sup> Cu, FIXCONNECT® terminal technology, for terminal technology refer to technical data
- N separable, up to 4 different potentials
- for the installation of DIN rail equipment, top hat profile 35 mm
- with transparent door
- for door locking device and sealing device refer to accessories
- with cable entry cover
- with blanking strips for unused DIN rail openings
- cable entry via integrated elastic membranes

rated insulation voltage	$U_i = 400 \text{ V a.c.}$
power dissipation capability	$P_{de} = 50 \text{ watts}$ according to EN 60670-24

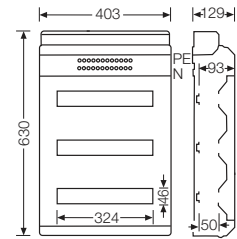

- 8xø7-12 mm
- 8xø7-14 mm
- 4xø12-20 mm
- 1xø16,5-29 mm
- 8xM20



**KV 3654**

**54 modules: 3 x 18 x 18 mm**  
**without PE and N terminal**

- 3-row
- order PE/N terminals separately
- for the installation of DIN rail equipment, top hat profile 35 mm
- with transparent door
- for door locking device and sealing device refer to accessories
- with cable entry cover
- with blanking strips for unused DIN rail openings
- cable entry via integrated elastic membranes

rated insulation voltage	$U_i = 400 \text{ V a.c.}$
power dissipation capability	$P_{de} = 50 \text{ watts}$ according to EN 60670-24

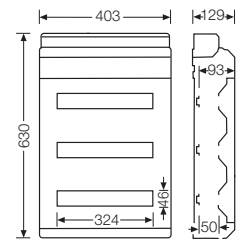

- 8xø7-12 mm
- 8xø7-14 mm
- 4xø12-20 mm
- 1xø16,5-29 mm
- 8xM20

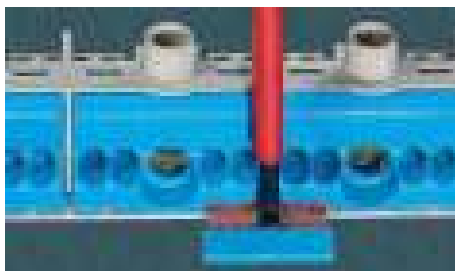

## KV small-type distribution boards

### Circuit breaker box

#### Cable entry via metric knockouts

- Compact user friendly solution, optically optimized by cable entry cover
- Integrated compartment for accessories - everything has its proper place
- DIN-rails with stopper for proper position of installation device
- Screws made of stainless steel V2A
- FIXCONNECT® plug-in terminal technology for PE and N
- Connection for copper conductors
- KV Small-type distribution boards with up to four disconnectable N-potentials in one bar enable the installation of RCDs without additional efforts or accessories
- 12 to 54 modules: attached blanking strips for DIN rail equipment openings
- Material: polystyrene
- Burning behaviour: glow wire test in accordance with IEC 60695-2-11: 750 °C, flame-retardant, self-extinguishing
- Colour: grey, RAL 7035



**KV 7103**

**3 modules: 1 x 3 x 18 mm**

- 1-row
- knockouts: top and bottom walls 2x M20 each
- per PE/N number x cross section 1 x 25 mm<sup>2</sup>, 4 x 4 mm<sup>2</sup> Cu, FIXCONNECT® terminal technology, for terminal technology refer to technical data
- for the installation of DIN rail equipment, top hat profile 35 mm
- with transparent lid, sealable
- locking device for hinged lid and sealing facility see accessories
- with cable entry cover
- protective cover can be cut out

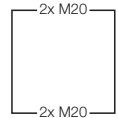
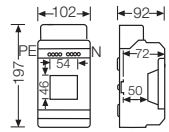

rated insulation voltage	$U_i = 400 \text{ V a.c.}$
power dissipation capability	$P_{de} = 10 \text{ watts}$ according to EN 60670-24



**KV 6103**

**3 modules: 1 x 3 x 18 mm**  
**without PE and N terminal**

- 1-row
- knockouts: top and bottom walls 2x M20 each
- order PE/N terminals separately
- for the installation of DIN rail equipment, top hat profile 35 mm
- with transparent lid, sealable
- locking device for hinged lid and sealing facility see accessories
- with cable entry cover
- protective cover can be cut out

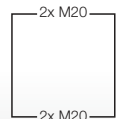
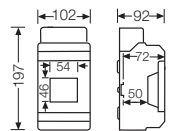

rated insulation voltage	$U_i = 400 \text{ V a.c.}$
power dissipation capability	$P_{de} = 10 \text{ watts}$ according to EN 60670-24

**KV small-type distribution boards**  
**Circuit breaker boxes**  
**Cable entry via metric knockouts**



**KV 7104**

**4.5 modules: 1 x 4.5 x 18 mm**

- 1-row
- knockouts: top and bottom walls 2x M20 and 1x M25/32 each
- per PE/N number x cross section 2 x 25 mm<sup>2</sup>, 4 x 4 mm<sup>2</sup> Cu, FIXCONNECT® terminal technology, for terminal technology refer to technical data
- for the installation of DIN rail equipment, top hat profile 35 mm
- with transparent lid, sealable
- locking device for hinged lid and sealing facility see accessories
- with cable entry cover
- protective cover can be cut out

rated insulation voltage	$U_i = 400 \text{ V a.c.}$
power dissipation capability	$P_{de} = 12 \text{ watts}$ according to EN 60670-24

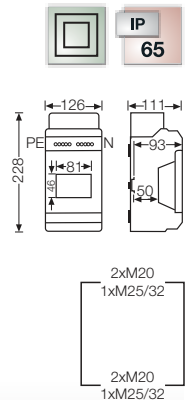

**KV 6104**

**4.5 modules: 1 x 4.5 x 18 mm**  
**without PE and N terminal**

- 1-row
- knockouts: top and bottom walls 2x M20 and 1x M25/32 each
- order PE/N terminals separately
- for the installation of DIN rail equipment, top hat profile 35 mm
- with transparent lid, sealable
- locking device for hinged lid and sealing facility see accessories
- with cable entry cover
- protective cover can be cut out

rated insulation voltage	$U_i = 400 \text{ V a.c.}$
power dissipation capability	$P_{de} = 12 \text{ watts}$ according to EN 60670-24

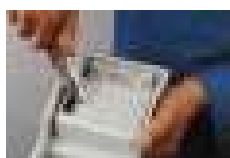
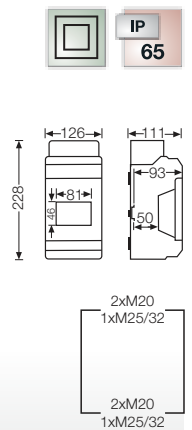

3 to 9 modules: protective cover can be cut out



British Standard installation with earthed armored cables



**KV 7106**

**6 modules: 1 x 6 x 18 mm**

- 1-row
- knockouts: top and bottom walls 2x M20/25 and 1x M25/32 each
- per PE/N number x cross section 2 x 25 mm<sup>2</sup>, 4 x 4 mm<sup>2</sup> Cu, FIXCONNECT® terminal technology, for terminal technology refer to technical data
- for the installation of DIN rail equipment, top hat profile 35 mm
- with transparent lid, sealable
- locking device for hinged lid and sealing facility see accessories
- with cable entry cover
- protective cover can be cut out

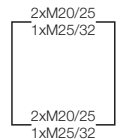
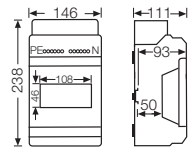

rated insulation voltage	$U_i = 400 \text{ V a.c.}$
power dissipation capability	$P_{de} = 13 \text{ watts}$ according to EN 60670-24



**KV 6106**

**6 modules: 1 x 6 x 18 mm**  
**without PE and N terminal**

- 1-row
- knockouts: top and bottom walls 2x M20/25 and 1x M25/32 each
- order PE/N terminals separately
- for the installation of DIN rail equipment, top hat profile 35 mm
- with transparent lid, sealable
- locking device for hinged lid and sealing facility see accessories
- with cable entry cover
- protective cover can be cut out

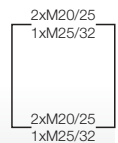
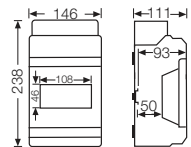

rated insulation voltage	$U_i = 400 \text{ V a.c.}$
power dissipation capability	$P_{de} = 13 \text{ watts}$ according to EN 60670-24

**KV small-type distribution boards**  
**Circuit breaker boxes**  
**Cable entry via metric knockouts**



**KV 7109**

**9 modules: 1 x 9 x 18 mm**

- 1-row
- knockouts: top and bottom walls 4x M20/25 and 1x M25/32 each
- per PE/N number x cross section 2 x 25 mm<sup>2</sup>, 8 x 4 mm<sup>2</sup> Cu, FIXCONNECT® terminal technology, for terminal technology refer to technical data
- for the installation of DIN rail equipment, top hat profile 35 mm
- with transparent lid, sealable
- locking device for hinged lid and sealing facility see accessories
- with cable entry cover
- protective cover can be cut out

rated insulation voltage	$U_i = 400 \text{ V a.c.}$
power dissipation capability	$P_{de} = 16 \text{ watts}$ according to EN 60670-24

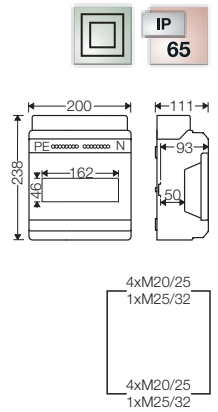

**KV 6109**

**9 modules: 1 x 9 x 18 mm**  
**without PE and N terminal**

- 1-row
- knockouts: top and bottom walls 4x M20/25 and 1x M25/32 each
- order PE/N terminals separately
- for the installation of DIN rail equipment, top hat profile 35 mm
- with transparent lid, sealable
- locking device for hinged lid and sealing facility see accessories
- with cable entry cover
- protective cover can be cut out

rated insulation voltage	$U_i = 400 \text{ V a.c.}$
power dissipation capability	$P_{de} = 16 \text{ watts}$ according to EN 60670-24

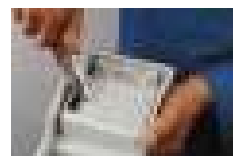
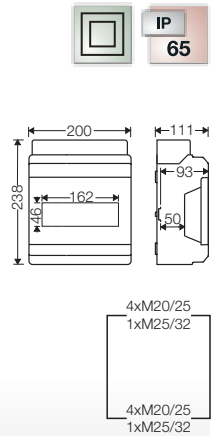

3 to 9 modules: protective cover can be cut out



British Standard installation with earthed armoured cables

**KV small-type distribution boards**  
**Circuit breaker boxes**  
**Cable entry via metric knockouts**



**KV 9112 M**

**12 modules: 1 x 12 x 18 mm**

- 1-row
- per PE/N number x cross section 3 x 25 mm<sup>2</sup>, 12 x 4 mm<sup>2</sup> Cu, FIXCONNECT® terminal technology, for terminal technology refer to technical data
- N separable, for up to 2 different potentials
- for the installation of DIN rail equipment, top hat profile 35 mm
- with transparent door
- for door locking device and sealing device refer to accessories
- with cable entry cover
- with blanking strips for unused DIN rail openings

rated insulation voltage	$U_i = 400 \text{ V a.c.}$
power dissipation capability	$P_{de} = 26 \text{ watts}$ according to EN 60670-24
permissible power dissipation	$P_{zul} = 21 \text{ watts at } 30 \text{ K}$ according to DIN 43871

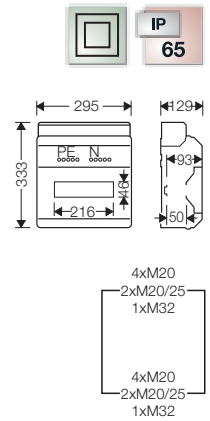

**KV 8112 M**

**12 modules: 1 x 12 x 18 mm**  
**without PE and N terminal**

- 1-row
- order PE/N terminals separately
- for the installation of DIN rail equipment, top hat profile 35 mm
- with transparent door
- for door locking device and sealing device refer to accessories
- with cable entry cover
- with blanking strips for unused DIN rail openings
- knockouts: top and bottom walls 4x M20, 2x M20/25 and 1x M32 each

rated insulation voltage	$U_i = 400 \text{ V a.c.}$
power dissipation capability	$P_{de} = 26 \text{ watts}$ according to EN 60670-24
permissible power dissipation	$P_{zul} = 21 \text{ watts at } 30 \text{ K}$ according to DIN 43871

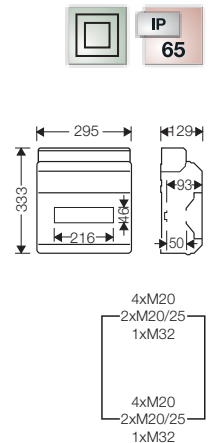

**KV small-type distribution boards**  
**Circuit breaker boxes**  
**Cable entry via metric knockouts**



**KV 1512 M**

**12 modules: 1 x 12 x 18 mm**

- 1-row
- per PE/N number x cross section 3 x 25 mm<sup>2</sup>, 12 x 4 mm<sup>2</sup> Cu, FIXCONNECT® terminal technology, for terminal technology refer to technical data
- N separable, for up to 2 different potentials
- for the installation of DIN rail equipment, top hat profile 35 mm
- with transparent door
- for door locking device and sealing device refer to accessories
- with cable entry cover
- with blanking strips for unused DIN rail openings
- knockouts: top and bottom walls 4x M20, 2x M20/25 and 1x M32 each

rated insulation voltage	$U_i = 400 \text{ V a.c.}$
power dissipation capability	$P_{de} = 26 \text{ watts}$ according to EN 60670-24
permissible power dissipation	$P_{zul} = 21 \text{ watts at } 30 \text{ K}$ according to DIN 43871

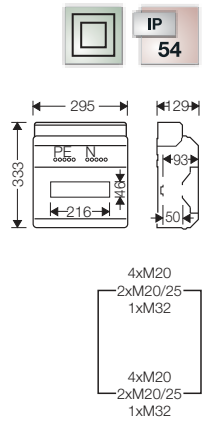

**KV 1612 M**

**12 modules: 1 x 12 x 18 mm**  
**without PE and N terminal**

- 1-row
- order PE/N terminals separately
- for the installation of DIN rail equipment, top hat profile 35 mm
- with transparent door
- for door locking device and sealing device refer to accessories
- with cable entry cover
- with blanking strips for unused DIN rail openings
- knockouts: top and bottom walls 4x M20, 2x M20/25 and 1x M32 each

rated insulation voltage	$U_i = 400 \text{ V a.c.}$
power dissipation capability	$P_{de} = 26 \text{ watts}$ according to EN 60670-24
permissible power dissipation	$P_{zul} = 21 \text{ watts at } 30 \text{ K}$ according to DIN 43871

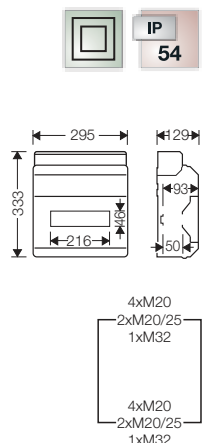

Variable installation depth by mounting DIN-rails in different levels



Included blanking strips



**KV 9118 M**

**18 modules: 1 x 18 x 18 mm**

- 1-row
- per PE/N number x cross section 4 x 25 mm<sup>2</sup>, 16 x 4 mm<sup>2</sup> Cu, FIXCONNECT® terminal technology, for terminal technology refer to technical data
- N separable, for up to 2 different potentials
- for the installation of DIN rail equipment, top hat profile 35 mm
- with transparent door
- for door locking device and sealing device refer to accessories
- with cable entry cover
- with blanking strips for unused DIN rail openings

rated insulation voltage	$U_i = 400 \text{ V a.c.}$
power dissipation capability	$P_{de} = 33 \text{ watts}$ according to EN 60670-24

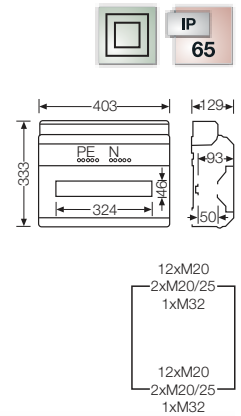

**KV 8118 M**

**18 modules: 1 x 18 x 18 mm  
without PE and N terminal**

- 1-row
- order PE/N terminals separately
- for the installation of DIN rail equipment, top hat profile 35 mm
- with transparent door
- for door locking device and sealing device refer to accessories
- with cable entry cover
- with blanking strips for unused DIN rail openings
- knockouts: top and bottom walls 12x M20, 2x M20/25 and 1x M32 each

rated insulation voltage	$U_i = 400 \text{ V a.c.}$
power dissipation capability	$P_{de} = 33 \text{ watts}$ according to EN 60670-24

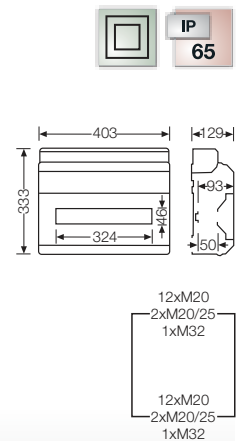

**KV 1518 M**

**18 modules: 1 x 18 x 18 mm**

- 1-row
- per PE/N number x cross section 4 x 25 mm<sup>2</sup>, 16 x 4 mm<sup>2</sup> Cu, FIXCONNECT® terminal technology, for terminal technology refer to technical data
- N separable, for up to 2 different potentials
- for the installation of DIN rail equipment, top hat profile 35 mm
- with transparent door
- for door locking device and sealing device refer to accessories
- with cable entry cover
- with blanking strips for unused DIN rail openings
- knockouts: top and bottom walls 12x M20, 2x M20/25 and 1x M32 each

rated insulation voltage	$U_i = 400 \text{ V a.c.}$
power dissipation capability	$P_{de} = 33 \text{ watts}$ according to EN 60670-24

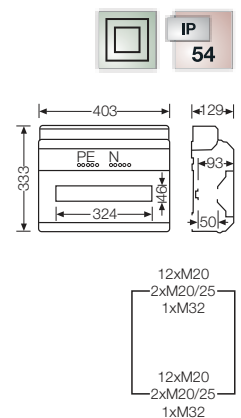



**KV 1618 M**

**18 modules: 1 x 18 x 18 mm**  
**without PE and N terminal**

- 1-row
- order PE/N terminals separately
- for the installation of DIN rail equipment, top hat profile 35 mm
- with transparent door
- for door locking device and sealing device refer to accessories
- with cable entry cover
- with blanking strips for unused DIN rail openings
- knockouts: top and bottom walls 12x M20, 2x M20/25 and 1x M32 each

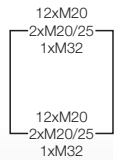
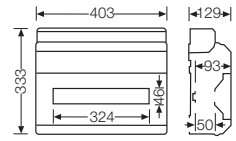

rated insulation voltage	$U_i = 400 \text{ V a.c.}$
power dissipation capability	$P_{de} = 33 \text{ watts}$ according to EN 60670-24



Variable installation depth by mounting DIN-rails in different levels



Included blanking strips

**KV small-type distribution boards**  
**Circuit breaker boxes**  
**Cable entry via metric knockouts**



**KV 9224 M**  
**24 modules: 2 x 12 x 18 mm**

- 2-row
- per PE/N number x cross section 6 x 25 mm<sup>2</sup>, 24 x 4 mm<sup>2</sup> Cu, FIXCONNECT® terminal technology, for terminal technology refer to technical data
- N separable, up to 4 different potentials
- for the installation of DIN rail equipment, top hat profile 35 mm
- with transparent door
- for door locking device and sealing device refer to accessories
- with cable entry cover
- with blanking strips for unused DIN rail openings

rated insulation voltage	$U_i = 400 \text{ V a.c.}$
power dissipation capability	$P_{de} = 31 \text{ watts}$ according to EN 60670-24
permissible power dissipation	$P_{zul} = 25 \text{ watts at } 30 \text{ K}$ according to DIN 43871

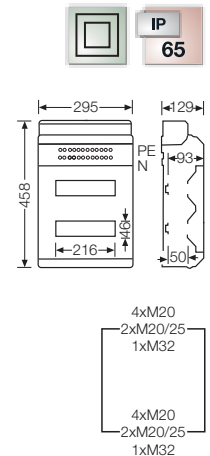

**KV 8224 M**  
**24 modules: 2 x 12 x 18 mm**  
**without PE and N terminal**

- 2-row
- order PE/N terminals separately
- for the installation of DIN rail equipment, top hat profile 35 mm
- with transparent door
- for door locking device and sealing device refer to accessories
- with cable entry cover
- with blanking strips for unused DIN rail openings
- knockouts: top and bottom walls 4x M20, 2x M20/25 and 1x M32 each

rated insulation voltage	$U_i = 400 \text{ V a.c.}$
power dissipation capability	$P_{de} = 31 \text{ watts}$ according to EN 60670-24
permissible power dissipation	$P_{zul} = 25 \text{ watts at } 30 \text{ K}$ according to DIN 43871

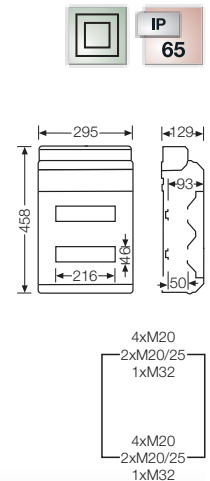

**KV small-type distribution boards**  
**Circuit breaker boxes**  
**Cable entry via metric knockouts**

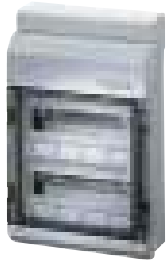

**KV 2524 M**  
**24 modules: 2 x 12 x 18 mm**

- 2-row
- per PE/N number x cross section 6 x 25 mm<sup>2</sup>, 24 x 4 mm<sup>2</sup> Cu, FIXCONNECT® terminal technology, for terminal technology refer to technical data
- N separable, up to 4 different potentials
- for the installation of DIN rail equipment, top hat profile 35 mm
- with transparent door
- for door locking device and sealing device refer to accessories
- with cable entry cover
- with blanking strips for unused DIN rail openings
- knockouts: top and bottom walls 4x M20, 2x M20/25 and 1x M32 each

rated insulation voltage	$U_i = 400 \text{ V a.c.}$
power dissipation capability	$P_{de} = 31 \text{ watts}$ according to EN 60670-24
permissible power dissipation	$P_{zul} = 25 \text{ watts at } 30 \text{ K}$ according to DIN 43871

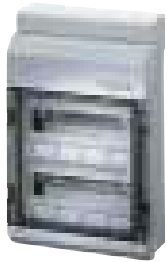
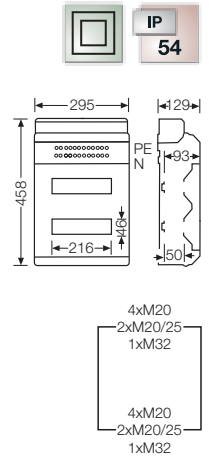

**KV 2624 M**  
**24 modules: 2 x 12 x 18 mm**  
**without PE and N terminal**

- 2-row
- order PE/N terminals separately
- for the installation of DIN rail equipment, top hat profile 35 mm
- with transparent door
- for door locking device and sealing device refer to accessories
- with cable entry cover
- with blanking strips for unused DIN rail openings
- knockouts: top and bottom walls 4x M20, 2x M20/25 and 1x M32 each

rated insulation voltage	$U_i = 400 \text{ V a.c.}$
power dissipation capability	$P_{de} = 31 \text{ watts}$ according to EN 60670-24
permissible power dissipation	$P_{zul} = 25 \text{ watts at } 30 \text{ K}$ according to DIN 43871

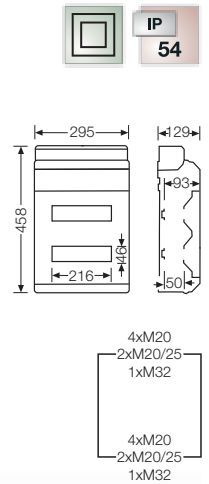

Variable installation depth by mounting DIN-rails in different levels



Included blanking strips

**KV small-type distribution boards**  
**Circuit breaker boxes**  
**Cable entry via metric knockouts**



**KV 9236 M**  
**36 modules: 2 x 18 x 18 mm**

- 2-row
- per PE/N number x cross section 8 x 25 mm<sup>2</sup>, 32 x 4 mm<sup>2</sup> Cu, FIXCONNECT® terminal technology, for terminal technology refer to technical data
- N separable, up to 4 different potentials
- for the installation of DIN rail equipment, top hat profile 35 mm
- with transparent door
- for door locking device and sealing device refer to accessories
- with cable entry cover
- with blanking strips for unused DIN rail openings

rated insulation voltage	$U_i = 400 \text{ V a.c.}$
power dissipation capability	$P_{de} = 38 \text{ watts}$ according to EN 60670-24

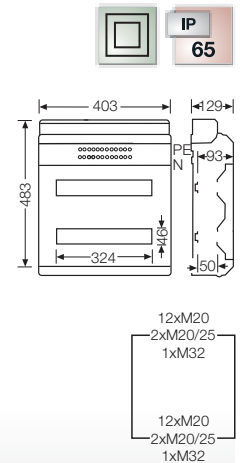

**KV 8236 M**  
**36 modules: 2 x 18 x 18 mm**  
**without PE and N terminal**

- 2-row
- order PE/N terminals separately
- for the installation of DIN rail equipment, top hat profile 35 mm
- with transparent door
- for door locking device and sealing device refer to accessories
- with cable entry cover
- with blanking strips for unused DIN rail openings
- knockouts: top and bottom walls 12x M20, 2x M20/25 and 1x M32 each

rated insulation voltage	$U_i = 400 \text{ V a.c.}$
power dissipation capability	$P_{de} = 38 \text{ watts}$ according to EN 60670-24

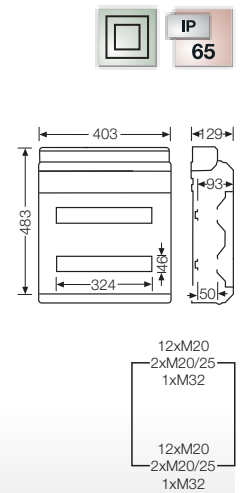

**KV 2536 M**  
**36 modules: 2 x 18 x 18 mm**

- 2-row
- per PE/N number x cross section 8 x 25 mm<sup>2</sup>, 32 x 4 mm<sup>2</sup> Cu, FIXCONNECT® terminal technology, for terminal technology refer to technical data
- N separable, up to 4 different potentials
- for the installation of DIN rail equipment, top hat profile 35 mm
- with transparent door
- for door locking device and sealing device refer to accessories
- with cable entry cover
- with blanking strips for unused DIN rail openings
- knockouts: top and bottom walls 12x M20, 2x M20/25 and 1x M32 each

rated insulation voltage	$U_i = 400 \text{ V a.c.}$
power dissipation capability	$P_{de} = 38 \text{ watts}$ according to EN 60670-24

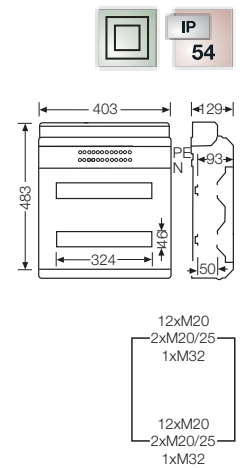

**KV small-type distribution boards**  
**Circuit breaker boxes**  
**Cable entry via metric knockouts**



**KV 2636 M**

**36 modules: 2 x 18 x 18 mm**  
**without PE and N terminal**

- 2-row
- order PE/N terminals separately
- for the installation of DIN rail equipment, top hat profile 35 mm
- with transparent door
- for door locking device and sealing device refer to accessories
- with cable entry cover
- with blanking strips for unused DIN rail openings
- knockouts: top and bottom walls 12x M20, 2x M20/25 and 1x M32 each

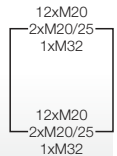
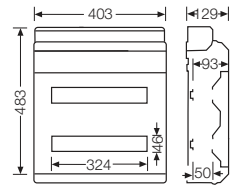

rated insulation voltage	$U_i = 400 \text{ V a.c.}$
power dissipation capability	$P_{de} = 38 \text{ watts}$ according to EN 60670-24



Variable installation depth by mounting DIN-rails in different levels



Included blanking strips

**KV small-type distribution boards**  
**Circuit breaker boxes**  
**Cable entry via metric knockouts**



**KV 9336 M**  
**36 modules: 3 x 12 x 18 mm**

- 3-row
- per PE/N number x cross section 6 x 25 mm<sup>2</sup>, 24 x 4 mm<sup>2</sup> Cu, FIXCONNECT® terminal technology, for terminal technology refer to technical data
- N separable, up to 4 different potentials
- for the installation of DIN rail equipment, top hat profile 35 mm
- with transparent door
- for door locking device and sealing device refer to accessories
- with cable entry cover
- with blanking strips for unused DIN rail openings

rated insulation voltage	$U_i = 400 \text{ V a.c.}$
power dissipation capability	$P_{de} = 35 \text{ watts}$ according to EN 60670-24
permissible power dissipation	$P_{zul} = 28 \text{ watts at } 30 \text{ K}$ according to DIN 43871

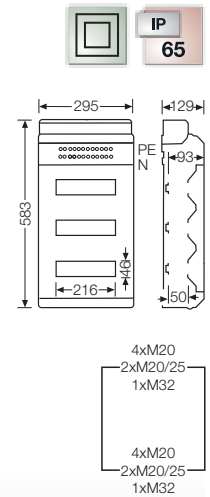

**KV 8336 M**  
**36 modules: 3 x 12 x 18 mm**  
**without PE and N terminal**

- 3-row
- order PE/N terminals separately
- for the installation of DIN rail equipment, top hat profile 35 mm
- with transparent door
- for door locking device and sealing device refer to accessories
- with cable entry cover
- with blanking strips for unused DIN rail openings
- knockouts: top and bottom walls 4x M20, 2x M20/25 and 1x M32 each

rated insulation voltage	$U_i = 400 \text{ V a.c.}$
power dissipation capability	$P_{de} = 35 \text{ watts}$ according to EN 60670-24
permissible power dissipation	$P_{zul} = 28 \text{ watts at } 30 \text{ K}$ according to DIN 43871

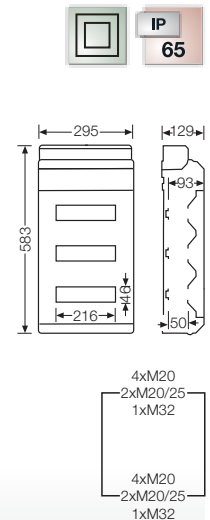

**KV small-type distribution boards**  
**Circuit breaker boxes**  
**Cable entry via metric knockouts**



**KV 3536 M**

**36 modules: 3 x 12 x 18 mm**

- 3-row
- per PE/N number x cross section 6 x 25 mm<sup>2</sup>, 24 x 4 mm<sup>2</sup> Cu, FIXCONNECT® terminal technology, for terminal technology refer to technical data
- N separable, up to 4 different potentials
- for the installation of DIN rail equipment, top hat profile 35 mm
- with transparent door
- for door locking device and sealing device refer to accessories
- with cable entry cover
- with blanking strips for unused DIN rail openings
- knockouts: top and bottom walls 4x M20, 2x M20/25 and 1x M32 each

rated insulation voltage	$U_i = 400 \text{ V a.c.}$
power dissipation capability	$P_{de} = 35 \text{ watts}$ according to EN 60670-24
permissible power dissipation	$P_{zul} = 28 \text{ watts at } 30 \text{ K}$ according to DIN 43871

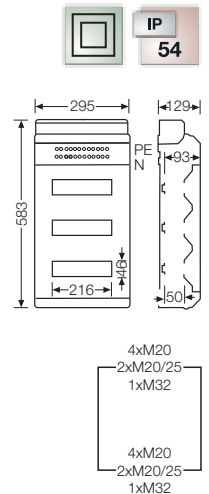

**KV 3636 M**

**36 modules: 3 x 12 x 18 mm**  
**without PE and N terminal**

- 3-row
- order PE/N terminals separately
- for the installation of DIN rail equipment, top hat profile 35 mm
- with transparent door
- for door locking device and sealing device refer to accessories
- with cable entry cover
- with blanking strips for unused DIN rail openings
- knockouts: top and bottom walls 4x M20, 2x M20/25 and 1x M32 each

rated insulation voltage	$U_i = 400 \text{ V a.c.}$
power dissipation capability	$P_{de} = 35 \text{ watts}$ according to EN 60670-24
permissible power dissipation	$P_{zul} = 28 \text{ watts at } 30 \text{ K}$ according to DIN 43871

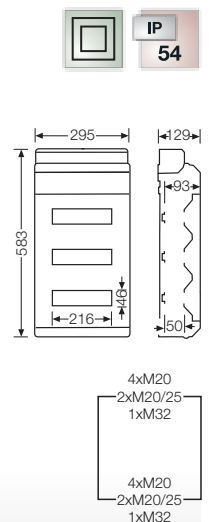

Variable installation depth by mounting DIN-rails in different levels



Included blanking strips



**KV 9448 M**

**48 modules: 4 x 12 x 18 mm**

- 4-row
- per PE/N number x cross section 6 x 25 mm<sup>2</sup>, 24 x 4 mm<sup>2</sup> Cu, FIXCONNECT® terminal technology, for terminal technology refer to technical data
- N separable, up to 4 different potentials
- for the installation of DIN rail equipment, top hat profile 35 mm
- with transparent door
- for door locking device and sealing device refer to accessories
- with cable entry cover
- with blanking strips for unused DIN rail openings
- knockouts: top and bottom walls 4x M20, 2x M20/25 and 1x M32 each

rated insulation voltage	$U_i = 400 \text{ V a.c.}$
power dissipation capability	$P_{de} = 43 \text{ watts}$ according to EN 60670-24
permissible power dissipation	$P_{zul} = 34 \text{ watts at } 30 \text{ K}$ according to DIN 43871

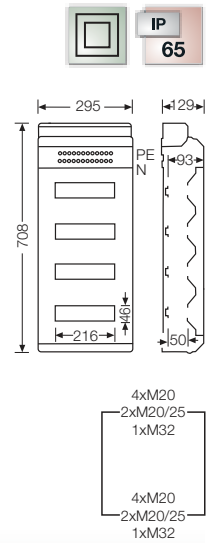

**KV 8448 M**

**48 modules: 4 x 12 x 18 mm**  
**without PE and N terminal**

- 4-row
- order PE/N terminals separately
- for the installation of DIN rail equipment, top hat profile 35 mm
- with transparent door
- for door locking device and sealing device refer to accessories
- with cable entry cover
- with blanking strips for unused DIN rail openings
- knockouts: top and bottom walls 4x M20, 2x M20/25 and 1x M32 each

rated insulation voltage	$U_i = 400 \text{ V a.c.}$
power dissipation capability	$P_{de} = 43 \text{ watts}$ according to EN 60670-24
permissible power dissipation	$P_{zul} = 34 \text{ watts at } 30 \text{ K}$ according to DIN 43871

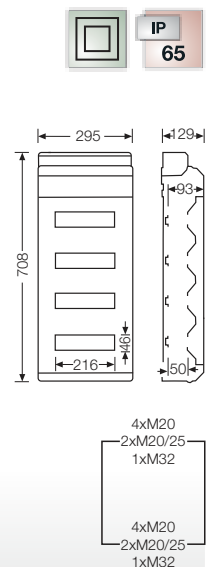

**KV small-type distribution boards**  
**Circuit breaker boxes**  
**Cable entry via metric knockouts**



**KV 4548 M**

**48 modules: 4 x 12 x 18 mm**

- 4-row
- per PE/N number x cross section 6 x 25 mm<sup>2</sup>, 24 x 4 mm<sup>2</sup> Cu, FIXCONNECT® terminal technology, for terminal technology refer to technical data
- N separable, up to 4 different potentials
- for the installation of DIN rail equipment, top hat profile 35 mm
- with transparent door
- for door locking device and sealing device refer to accessories
- with cable entry cover
- with blanking strips for unused DIN rail openings
- knockouts: top and bottom walls 4x M20, 2x M20/25 and 1x M32 each

rated insulation voltage	$U_i = 400 \text{ V a.c.}$
power dissipation capability	$P_{de} = 43 \text{ watts}$ according to EN 60670-24
permissible power dissipation	$P_{zul} = 34 \text{ watts at } 30 \text{ K}$ according to DIN 43871

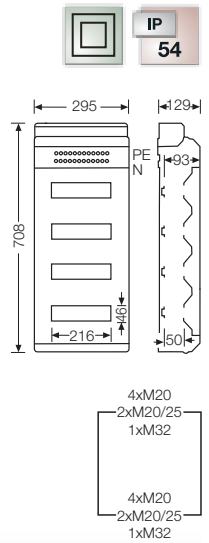

**KV 4648 M**

**48 modules: 4 x 12 x 18 mm**  
**without PE and N terminal**

- 4-row
- order PE/N terminals separately
- for the installation of DIN rail equipment, top hat profile 35 mm
- with transparent door
- for door locking device and sealing device refer to accessories
- with cable entry cover
- with blanking strips for unused DIN rail openings
- knockouts: top and bottom walls 4x M20, 2x M20/25 and 1x M32 each

rated insulation voltage	$U_i = 400 \text{ V a.c.}$
power dissipation capability	$P_{de} = 43 \text{ watts}$ according to EN 60670-24
permissible power dissipation	$P_{zul} = 34 \text{ watts at } 30 \text{ K}$ according to DIN 43871

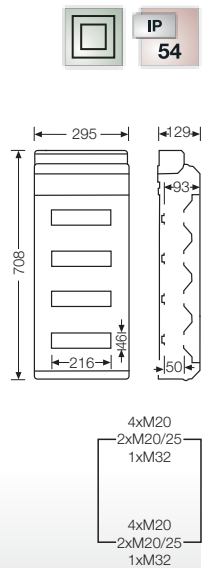

Variable installation depth by mounting DIN-rails in different levels



Included blanking strips

**KV small-type distribution boards**  
**Circuit breaker boxes**  
**Cable entry via metric knockouts**



**KV 9354 M**  
**54 modules: 3 x 18 x 18 mm**

- 3-row
- per PE/N number x cross section 8 x 25 mm<sup>2</sup>, 32 x 4 mm<sup>2</sup> Cu, FIXCONNECT® terminal technology, for terminal technology refer to technical data
- N separable, up to 4 different potentials
- for the installation of DIN rail equipment, top hat profile 35 mm
- with transparent door
- for door locking device and sealing device refer to accessories
- with cable entry cover
- with blanking strips for unused DIN rail openings

rated insulation voltage	$U_i = 400 \text{ V a.c.}$
power dissipation capability	$P_{de} = 50 \text{ watts}$ according to EN 60670-24

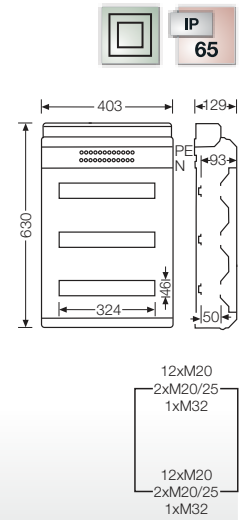

**KV 8354 M**  
**54 modules: 3 x 18 x 18 mm**  
**without PE and N terminal**

- 3-row
- order PE/N terminals separately
- for the installation of DIN rail equipment, top hat profile 35 mm
- with transparent door
- for door locking device and sealing device refer to accessories
- with cable entry cover
- with blanking strips for unused DIN rail openings
- knockouts: top and bottom walls 12x M20, 2x M20/25 and 1x M32 each

rated insulation voltage	$U_i = 400 \text{ V a.c.}$
power dissipation capability	$P_{de} = 50 \text{ watts}$ according to EN 60670-24

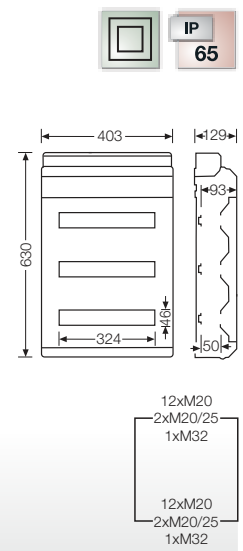

**KV 3554 M**  
**54 modules: 3 x 18 x 18 mm**

- 3-row
- per PE/N number x cross section 8 x 25 mm<sup>2</sup>, 32 x 4 mm<sup>2</sup> Cu, FIXCONNECT® terminal technology, for terminal technology refer to technical data
- N separable, up to 4 different potentials
- for the installation of DIN rail equipment, top hat profile 35 mm
- with transparent door
- for door locking device and sealing device refer to accessories
- with cable entry cover
- with blanking strips for unused DIN rail openings
- knockouts: top and bottom walls 12x M20, 2x M20/25 and 1x M32 each

rated insulation voltage	$U_i = 400 \text{ V a.c.}$
power dissipation capability	$P_{de} = 50 \text{ watts}$ according to EN 60670-24

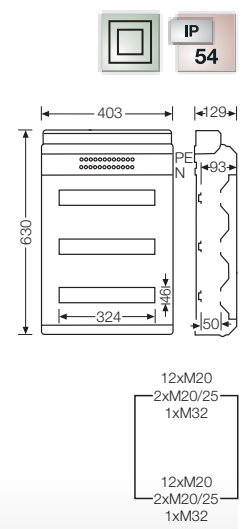

**KV small-type distribution boards**  
**Circuit breaker boxes**  
**Cable entry via metric knockouts**



**KV 3654 M**

**54 modules: 3 x 18 x 18 mm**  
**without PE and N terminal**

- 3-row
- order PE/N terminals separately
- for the installation of DIN rail equipment, top hat profile 35 mm
- with transparent door
- for door locking device and sealing device refer to accessories
- with cable entry cover
- with blanking strips for unused DIN rail openings
- knockouts: top and bottom walls 12x M20, 2x M20/25 and 1x M32 each

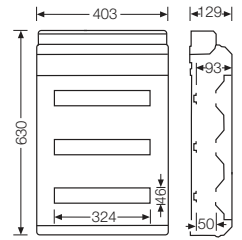

rated insulation voltage	$U_i = 400 \text{ V a.c.}$
power dissipation capability	$P_{de} = 50 \text{ watts}$ according to EN 60670-24

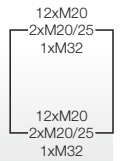

Variable installation depth by mounting DIN-rails in different levels



Included blanking strips

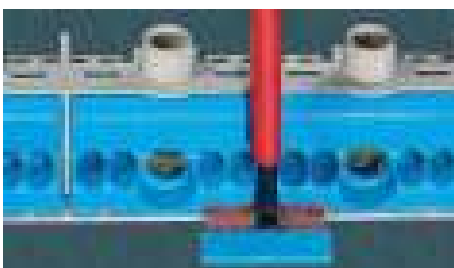

## KV small-type distribution boards

### Circuit breaker box

”Weatherproof“ for outdoor installation

- Compact user friendly solution, optically optimized by cable entry cover
- Integrated compartment for accessories - everything has its proper place
- DIN-rails with stopper for proper position of installation device
- Screws made of stainless steel V2A
- Cable entry via integrated elastic membranes
- Cable entry via metric knockouts
- FIXCONNECT® plug-in terminal technology for PE and N
- Connection for copper conductors
- KV Small-type distribution boards with up to four disconnectable N-potentials in one bar enable the installation of RCDs without additional efforts or accessories
- 12 to 54 modules: attached blanking strips for DIN rail equipment openings
- 3 to 9 modules: protective cover can be cut out
- Material: polycarbonate
- Burning behaviour: Glow wire test in accordance with IEC 60695-2-11: 960 °C, flame-retardant, self-extinguishing
- Colour: grey, RAL 7035

**KV small-type distribution boards**  
**Circuit breaker boxes "weatherproof", for outdoor installation**  
**Cable entry via metric knockouts**



**KV PC 9103**  
**3 modules: 1 x 3 x 18 mm**

- 1-row
- per PE/N number x cross section 1 x 25 mm<sup>2</sup>, 4 x 4 mm<sup>2</sup> Cu, FIXCONNECT® terminal technology, for terminal technology refer to technical data
- for indoor (normal environment and/or protected outdoor) and outdoor installation (harsh environment and/or outdoor)
- for the installation of DIN rail equipment, top hat profile 35 mm
- with transparent lid, sealable
- locking device for hinged lid and sealing facility see accessories
- with cable entry cover
- protective cover can be cut out

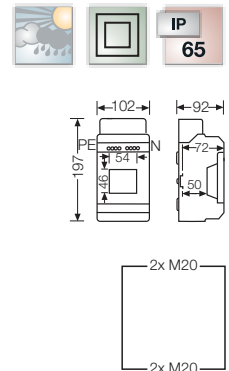

rated insulation voltage	$U_i = 400 \text{ V a.c.}$
power dissipation capability	$P_{de} = 10 \text{ watts}$ according to EN 60670-24



**KV PC 6103**  
**3 modules: 1 x 3 x 18 mm**  
**without PE and N terminal**

- 1-row
- knockouts: top and bottom walls 2x M20 each
- order PE/N terminals separately
- for indoor (normal environment and/or protected outdoor) and outdoor installation (harsh environment and/or outdoor)
- for the installation of DIN rail equipment, top hat profile 35 mm
- with transparent lid, sealable
- locking device for hinged lid and sealing facility see accessories
- with cable entry cover
- protective cover can be cut out

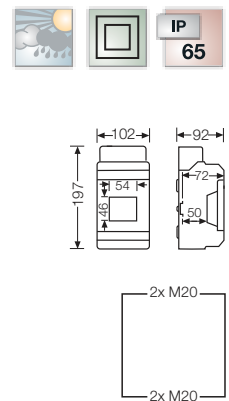

rated insulation voltage	$U_i = 400 \text{ V a.c.}$ $U_i = 1000 \text{ V d.c.}$
power dissipation capability	$P_{de} = 10 \text{ watts}$ according to EN 60670-24



**KV PC 9104**  
**4.5 modules: 1 x 4.5 x 18 mm**

- 1-row
- per PE/N number x cross section 2 x 25 mm<sup>2</sup>, 4 x 4 mm<sup>2</sup> Cu, FIXCONNECT® terminal technology, for terminal technology refer to technical data
- for indoor (normal environment and/or protected outdoor) and outdoor installation (harsh environment and/or outdoor)
- for the installation of DIN rail equipment, top hat profile 35 mm
- with transparent lid, sealable
- locking device for hinged lid and sealing facility see accessories
- with cable entry cover
- protective cover can be cut out

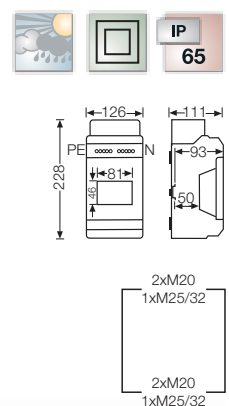

rated insulation voltage	$U_i = 400 \text{ V a.c.}$
power dissipation capability	$P_{de} = 12 \text{ watts}$ according to EN 60670-24

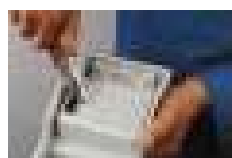

3 to 9 modules: protective cover can be cut out



British Standard installation with earthed armoured cables

**KV small-type distribution boards**  
**Circuit breaker boxes „weatherproof“, for outdoor installation**  
**Cable entry via metric knockouts**



**KV PC 6104**  
**4.5 modules: 1 x 4.5 x 18 mm**  
**without PE and N terminal**



- 1-row
- knockouts: top and bottom walls 2x M20 and 1x M25/32 each
- order PE/N terminals separately
- for indoor (normal environment and/or protected outdoor) and outdoor installation (harsh environment and/or outdoor)
- for the installation of DIN rail equipment, top hat profile 35 mm
- with transparent lid, sealable
- locking device for hinged lid and sealing facility see accessories
- with cable entry cover
- protective cover can be cut out

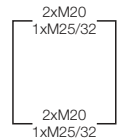
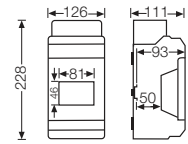

rated insulation voltage	$U_i = 400 \text{ V a.c.}$ $U_i = 1000 \text{ V d.c.}$
power dissipation capability	$P_{de} = 12 \text{ watts}$ according to EN 60670-24



**KV PC 9106**  
**6 modules: 1 x 6 x 18 mm**



- 1-row
- knockouts: top and bottom walls 2x M20/25 and 1x M25/32 each
- per PE/N number x cross section 2 x 25 mm<sup>2</sup>, 4 x 4 mm<sup>2</sup> Cu, FIXCONNECT® terminal technology, for terminal technology refer to technical data
- for indoor (normal environment and/or protected outdoor) and outdoor installation (harsh environment and/or outdoor)
- for the installation of DIN rail equipment, top hat profile 35 mm
- with transparent lid, sealable
- locking device for hinged lid and sealing facility see accessories
- with cable entry cover
- protective cover can be cut out

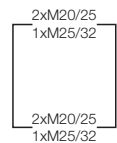
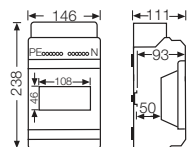

rated insulation voltage	$U_i = 400 \text{ V a.c.}$
power dissipation capability	$P_{de} = 13 \text{ watts}$ according to EN 60670-24



**KV PC 6106**  
**6 modules: 1 x 6 x 18 mm**  
**without PE and N terminal**



- 1-row
- knockouts: top and bottom walls 2x M20/25 and 1x M25/32 each
- order PE/N terminals separately
- for indoor (normal environment and/or protected outdoor) and outdoor installation (harsh environment and/or outdoor)
- for the installation of DIN rail equipment, top hat profile 35 mm
- with transparent lid, sealable
- locking device for hinged lid and sealing facility see accessories
- with cable entry cover
- protective cover can be cut out

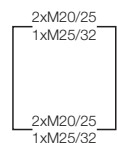
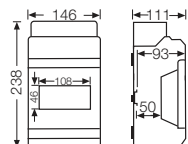

rated insulation voltage	$U_i = 400 \text{ V a.c.}$ $U_i = 1000 \text{ V d.c.}$
power dissipation capability	$P_{de} = 13 \text{ watts}$ according to EN 60670-24

**KV small-type distribution boards**  
**Circuit breaker boxes „weatherproof“, for outdoor installation**  
**Cable entry via metric knockouts**



**KV PC 9109**  
**9 modules: 1 x 9 x 18 mm**

- 1-row
- per PE/N number x cross section 2 x 25 mm<sup>2</sup>, 8 x 4 mm<sup>2</sup> Cu, FIXCONNECT® terminal technology, for terminal technology refer to technical data
- for indoor (normal environment and/or protected outdoor) and outdoor installation (harsh environment and/or outdoor)
- for the installation of DIN rail equipment, top hat profile 35 mm
- with transparent lid, sealable
- locking device for hinged lid and sealing facility see accessories
- with cable entry cover
- protective cover can be cut out

rated insulation voltage	$U_i = 400 \text{ V a.c.}$
power dissipation capability	$P_{de} = 16 \text{ watts}$ according to EN 60670-24

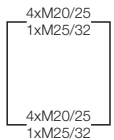
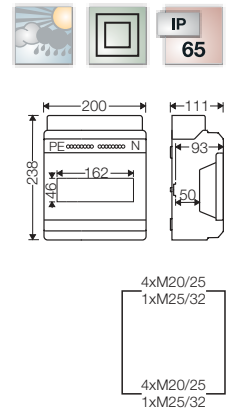

**KV PC 6109**  
**9 modules: 1 x 9 x 18 mm**  
**without PE and N terminal**

- 1-row
- knockouts: top and bottom walls 4x M20/25 and 1x M25/32 each
- order PE/N terminals separately
- for indoor (normal environment and/or protected outdoor) and outdoor installation (harsh environment and/or outdoor)
- for the installation of DIN rail equipment, top hat profile 35 mm
- with transparent lid, sealable
- locking device for hinged lid and sealing facility see accessories
- with cable entry cover
- protective cover can be cut out

rated insulation voltage	$U_i = 400 \text{ V a.c.}$ $U_i = 1000 \text{ V d.c.}$
power dissipation capability	$P_{de} = 16 \text{ watts}$ according to EN 60670-24

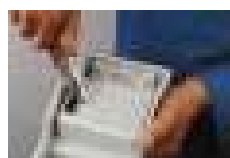
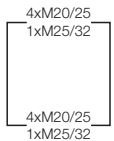
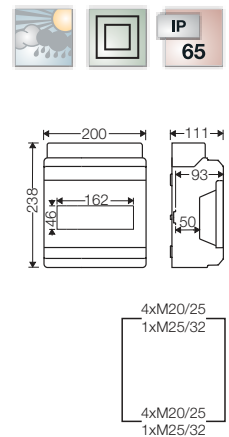

3 to 9 modules: protective cover can be cut out



British Standard installation with earthed armoured cables

**KV small-type distribution boards**  
**Circuit breaker boxes "weatherproof", for outdoor installation**  
**Cable entry via integrated elastic membranes**



**KV PC 9112**  
**12 modules: 1 x 12 x 18 mm**

- 1-row
- cable entry via integrated elastic membranes
- per PE/N number x cross section 3 x 25 mm<sup>2</sup>, 12 x 4 mm<sup>2</sup> Cu, FIXCONNECT® terminal technology, for terminal technology refer to technical data
- N separable, for up to 2 different potentials
- for indoor (normal environment and/or protected outdoor) and outdoor installation (harsh environment and/or outdoor)
- for the installation of DIN rail equipment, top hat profile 35 mm
- with transparent door
- for door locking device and sealing device refer to accessories
- with cable entry cover
- with blanking strips for unused DIN rail openings
- lateral enclosure connections can be managed by drilling

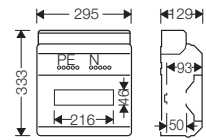

- 8xø7-12 mm
- 8xø7-14 mm
- 4xø12-20 mm
- 1xø16,5-29 mm

rated insulation voltage	$U_i = 400 \text{ V a.c.}$
power dissipation capability	$P_{de} = 26 \text{ watts}$ according to EN 60670-24
permissible power dissipation	$P_{zul} = 21 \text{ watts at } 30 \text{ K}$ according to DIN 43871



**KV PC 9224**  
**24 modules: 2 x 12 x 18 mm**

- 2-row
- cable entry via integrated elastic membranes
- per PE/N number x cross section 6 x 25 mm<sup>2</sup>, 24 x 4 mm<sup>2</sup> Cu, FIXCONNECT® terminal technology, for terminal technology refer to technical data
- N separable, up to 4 different potentials
- for indoor (normal environment and/or protected outdoor) and outdoor installation (harsh environment and/or outdoor)
- for the installation of DIN rail equipment, top hat profile 35 mm
- with transparent door
- for door locking device and sealing device refer to accessories
- with cable entry cover
- with blanking strips for unused DIN rail openings
- lateral enclosure connections can be managed by drilling

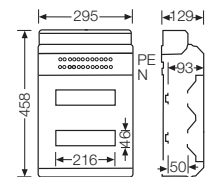

- 8xø7-12 mm
- 8xø7-14 mm
- 4xø12-20 mm
- 1xø16,5-29 mm

rated insulation voltage	$U_i = 400 \text{ V a.c.}$
power dissipation capability	$P_{de} = 31 \text{ watts}$ according to EN 60670-24
permissible power dissipation	$P_{zul} = 25 \text{ watts at } 30 \text{ K}$ according to DIN 43871

**KV small-type distribution boards**  
**Circuit breaker boxes „weatherproof“, for outdoor installation**  
**Cable entry via integrated elastic membranes**



**KV PC 9336**  
**36 modules: 3 x 12 x 18 mm**

- 3-row
- cable entry via integrated elastic membranes
- per PE/N number x cross section 6 x 25 mm<sup>2</sup>, 24 x 4 mm<sup>2</sup> Cu, FIXCONNECT® terminal technology, for terminal technology refer to technical data
- N separable, up to 4 different potentials
- for indoor (normal environment and/or protected outdoor) and outdoor installation (harsh environment and/or outdoor)
- for the installation of DIN rail equipment, top hat profile 35 mm
- with transparent door
- for door locking device and sealing device refer to accessories
- with cable entry cover
- with blanking strips for unused DIN rail openings
- lateral enclosure connections can be managed by drilling

rated insulation voltage	$U_i = 400 \text{ V a.c.}$
power dissipation capability	$P_{de} = 35 \text{ watts}$ according to EN 60670-24
permissible power dissipation	$P_{zul} = 28 \text{ watts at } 30 \text{ K}$ according to DIN 43871

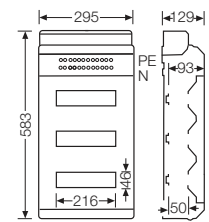

- 8xø7-12 mm
  - 8xø7-14 mm
  - 4xø12-20 mm
  - 1xø16,5-29 mm
- 
- 8xø7-12 mm
  - 8xø7-14 mm
  - 4xø12-20 mm
  - 1xø16,5-29 mm



**KV PC 9448**  
**48 modules: 4 x 12 x 18 mm**

- 4-row
- cable entry via integrated elastic membranes
- per PE/N number x cross section 6 x 25 mm<sup>2</sup>, 24 x 4 mm<sup>2</sup> Cu, FIXCONNECT® terminal technology, for terminal technology refer to technical data
- N separable, up to 4 different potentials
- for indoor (normal environment and/or protected outdoor) and outdoor installation (harsh environment and/or outdoor)
- for the installation of DIN rail equipment, top hat profile 35 mm
- with transparent door
- for door locking device and sealing device refer to accessories
- with cable entry cover
- with blanking strips for unused DIN rail openings
- lateral enclosure connections can be managed by drilling

rated insulation voltage	$U_i = 400 \text{ V a.c.}$
power dissipation capability	$P_{de} = 43 \text{ watts}$ according to EN 60670-24
permissible power dissipation	$P_{zul} = 34 \text{ watts at } 30 \text{ K}$ according to DIN 43871

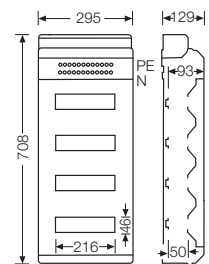

- 8xø7-12 mm
  - 8xø7-14 mm
  - 4xø12-20 mm
  - 1xø16,5-29 mm
- 
- 8xø7-12 mm
  - 8xø7-14 mm
  - 4xø12-20 mm
  - 1xø16,5-29 mm



Variable installation depth by mounting DIN-rails in different levels



Included blanking strips



### **KV small-type distribution boards**

#### **KV small-type distribution boards**

##### **Conduit entry via integrated elastic membranes**

- Integrated compartment for accessories - everything has its proper place
- Screws made of stainless steel V2A
- Conduit entry via integrated elastic membranes
- FIXCONNECT® plug-in terminal technology for PE and N
- Connection for copper conductors
- KV Small-type distribution boards with up to four disconnectable N-potentials in one bar enable the installation of RCDs without additional efforts or accessories
- 12 to 54 modules: attached blanking strips for DIN rail equipment openings
- Material: polystyrene
- Burning behaviour:  
glow wire test in accordance with IEC 60695-2-11: 750 °C,  
flame-retardant, self-extinguishing
- Colour: grey, RAL 7035

**KV small-type distribution boards**  
**Circuit breaker boxes**  
**Conduit entry via integrated elastic membranes**



**KV 1712**

**12 modules: 1 x 12 x 18 mm**

- 1-row
- per PE/N number x cross section 3 x 25 mm<sup>2</sup>, 12 x 4 mm<sup>2</sup> Cu, FIXCONNECT® terminal technology, for terminal technology refer to technical data
- N separable, for up to 2 different potentials
- for the installation of DIN rail equipment, top hat profile 35 mm
- with transparent door
- for door locking device and sealing device refer to accessories
- with cable entry cover
- with blanking strips for unused DIN rail openings
- with cable glands for conduits and elastic membranes

rated insulation voltage	$U_i = 400$ V a.c.
power dissipation capability	$P_{de} = 26$ watts according to EN 60670-24
permissible power dissipation	$P_{zul} = 21$ watts at 30 K according to DIN 43871

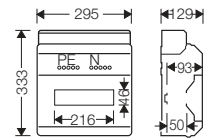

8 x M 16/20 for conduit or cable Ø 9-14 mm,  
 1 x M25/32 for conduit or cable Ø 18-24 mm,  
 6 x Ø 9-18 mm

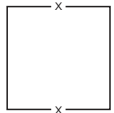

**KV 1718**

**18 modules: 1 x 18 x 18 mm**

- 1-row
- per PE/N number x cross section 4 x 25 mm<sup>2</sup>, 16 x 4 mm<sup>2</sup> Cu, FIXCONNECT® terminal technology, for terminal technology refer to technical data
- N separable, for up to 2 different potentials
- for the installation of DIN rail equipment, top hat profile 35 mm
- with transparent door
- for door locking device and sealing device refer to accessories
- with cable entry cover
- with blanking strips for unused DIN rail openings
- with cable glands for conduits and elastic membranes

rated insulation voltage	$U_i = 400$ V a.c.
power dissipation capability	$P_{de} = 33$ watts according to EN 60670-24

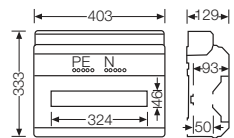

8 x M 16/20 for conduit or cable Ø 9-14 mm,  
 1 x M25/32 for conduit or cable Ø 18-24 mm,  
 6 x Ø 9-18 mm

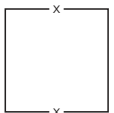

Variable installation depth by mounting DIN-rails in different levels



Included blanking strips

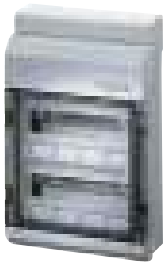

**KV 2724**

**24 modules: 2 x 12 x 18 mm**

- 2-row
- per PE/N number x cross section 6 x 25 mm<sup>2</sup>, 24 x 4 mm<sup>2</sup> Cu, FIXCONNECT® terminal technology, for terminal technology refer to technical data
- N separable, up to 4 different potentials
- for the installation of DIN rail equipment, top hat profile 35 mm
- with transparent door
- for door locking device and sealing device refer to accessories
- with cable entry cover
- with blanking strips for unused DIN rail openings
- with cable glands for conduits and elastic membranes

rated insulation voltage	$U_i = 400 \text{ V a.c.}$
power dissipation capability	$P_{de} = 31 \text{ watts}$ according to EN 60670-24
permissible power dissipation	$P_{zul} = 25 \text{ watts at } 30 \text{ K}$ according to DIN 43871

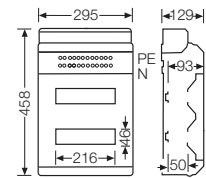

8 x M 16/20 for conduit or cable Ø 9-14 mm,  
 1 x M25/32 for conduit or cable Ø 18-24 mm,  
 6 x Ø 9-18 mm

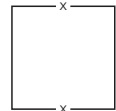

**KV 2736**

**36 modules: 2 x 18 x 18 mm**

- 2-row
- per PE/N number x cross section 8 x 25 mm<sup>2</sup>, 32 x 4 mm<sup>2</sup> Cu, FIXCONNECT® terminal technology, for terminal technology refer to technical data
- N separable, up to 4 different potentials
- for the installation of DIN rail equipment, top hat profile 35 mm
- with transparent door
- for door locking device and sealing device refer to accessories
- with cable entry cover
- with blanking strips for unused DIN rail openings
- with cable glands for conduits and elastic membranes

rated insulation voltage	$U_i = 400 \text{ V a.c.}$
power dissipation capability	$P_{de} = 38 \text{ watts}$ according to EN 60670-24

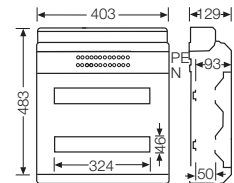

8 x M 16/20 for conduit or cable Ø 9-14 mm,  
 1 x M25/32 for conduit or cable Ø 18-24 mm,  
 6 x Ø 9-18 mm

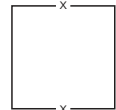

**KV 3736**

**36 modules: 3 x 12 x 18 mm**

- 3-row
- per PE/N number x cross section 6 x 25 mm<sup>2</sup>, 24 x 4 mm<sup>2</sup> Cu, FIXCONNECT® terminal technology, for terminal technology refer to technical data
- N separable, up to 4 different potentials
- for the installation of DIN rail equipment, top hat profile 35 mm
- with transparent door
- for door locking device and sealing device refer to accessories
- with cable entry cover
- with blanking strips for unused DIN rail openings
- with cable glands for conduits and elastic membranes

rated insulation voltage	$U_i = 400 \text{ V a.c.}$
power dissipation capability	$P_{de} = 35 \text{ watts}$ according to EN 60670-24
permissible power dissipation	$P_{zul} = 28 \text{ watts at } 30 \text{ K}$ according to DIN 43871

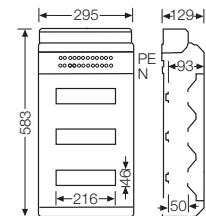

8 x M 16/20 for conduit or cable Ø 9-14 mm,  
 1 x M25/32 for conduit or cable Ø 18-24 mm,  
 6 x Ø 9-18 mm

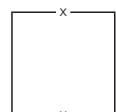

**KV small-type distribution boards**  
**Circuit breaker boxes**  
**Conduit entry via integrated elastic membranes**



**KV 3754**  
**54 modules: 3 x 18 x 18 mm**

- 3-row
- per PE/N number x cross section 8 x 25 mm<sup>2</sup>, 32 x 4 mm<sup>2</sup> Cu, FIXCONNECT® terminal technology, for terminal technology refer to technical data
- N separable, up to 4 different potentials
- for the installation of DIN rail equipment, top hat profile 35 mm
- with transparent door
- for door locking device and sealing device refer to accessories
- with cable entry cover
- with blanking strips for unused DIN rail openings
- with cable glands for conduits and elastic membranes

rated insulation voltage	$U_i = 400 \text{ V a.c.}$
power dissipation capability	$P_{de} = 50 \text{ watts}$ according to EN 60670-24

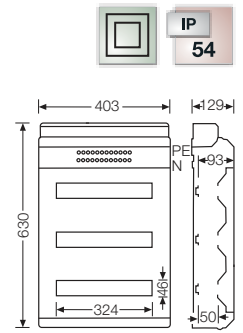

8 x M 16/20 for conduit or cable Ø 9-14 mm,  
 1 x M25/32 for conduit or cable Ø 18-24 mm,  
 6 x Ø 9-18 mm



**KV 4748**  
**48 modules: 4 x 12 x 18 mm**

- 4-row
- per PE/N number x cross section 6 x 25 mm<sup>2</sup>, 24 x 4 mm<sup>2</sup> Cu, FIXCONNECT® terminal technology, for terminal technology refer to technical data
- N separable, up to 4 different potentials
- for the installation of DIN rail equipment, top hat profile 35 mm
- with transparent door
- for door locking device and sealing device refer to accessories
- with cable entry cover
- with blanking strips for unused DIN rail openings
- with cable glands for conduits and elastic membranes

rated insulation voltage	$U_i = 400 \text{ V a.c.}$
power dissipation capability	$P_{de} = 43 \text{ watts}$ according to EN 60670-24
permissible power dissipation	$P_{zul} = 34 \text{ watts at } 30 \text{ K}$ according to DIN 43871

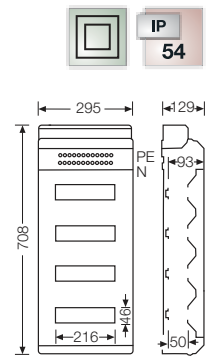

8 x M 16/20 for conduit or cable Ø 9-14 mm,  
 1 x M25/32 for conduit or cable Ø 18-24 mm,  
 6 x Ø 9-18 mm



Variable installation depth by mounting DIN-rails in different levels



Included blanking strips



KV Small-type distribution boards



### **KV small-type distribution boards**

**Circuit breaker boxes with additional space for electrical devices not to be manually actuated**

**Cable entry via elastic membranes**

- Pre-assembly and wiring in the workshop is possible in case of built-in terminal blocks
- Within the same enclosure standard-conforming installation devices (sizes according to DIN 43880) and non-operator-controlled devices can be installed
- Compact user friendly solution, optically optimized by cable entry cover
- Integrated compartment for accessories - everything has its proper place
- DIN-rails with stopper for proper position of installation device
- Screws made of stainless steel V2A
- Cable entry via integrated elastic membranes
- 12 to 36 modules: blanking strips for unused DIN rail openings included
- Burning behaviour: glow wire test in accordance with IEC 60695-2-11: 750 °C, flame-retardant, self-extinguishing
- Colour: grey, RAL 7035

**KV small-type distribution boards**

Circuit breaker boxes with additional space for electrical devices not to be manually actuated  
Cable entry via integrated elastic membranes



**KV 9220**

**12 modules: 1 x 12 x 18 mm  
without PE and N terminal**

- 1-row
- order PE/N terminals separately
- for the installation of DIN rail equipment, top hat profile 35 mm
- with additional space for electrical devices not to be manually actuated
- with 1 DIN rail, 273 mm wide, for DIN rail equipment and terminal blocks with max. mounting depth 72 mm
- with transparent door
- for door locking device and sealing device refer to accessories
- with cable entry cover
- with blanking strips for unused DIN rail openings
- cable entry via integrated elastic membranes

rated insulation voltage	$U_i = 400 \text{ V a.c.}$
power dissipation capability	$P_{de} = 26 \text{ watts}$ according to EN 60670-24
permissible power dissipation	$P_{zul} = 21 \text{ watts at } 30 \text{ K}$ according to DIN 43871

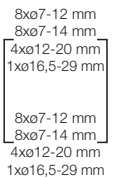
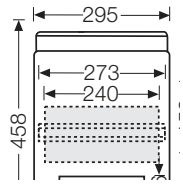

**KV 9230**

**18 modules: 1 x 18 x 18 mm  
without PE and N terminal**

- 1-row
- order PE/N terminals separately
- for the installation of DIN rail equipment, top hat profile 35 mm
- with additional space for electrical devices not to be manually actuated
- with 1 DIN rail, 381 mm wide, for DIN rail equipment and terminal blocks with max. mounting depth 72 mm
- with transparent door
- for door locking device and sealing device refer to accessories
- with cable entry cover
- with blanking strips for unused DIN rail openings
- cable entry via integrated elastic membranes

rated insulation voltage	$U_i = 400 \text{ V a.c.}$
power dissipation capability	$P_{de} = 33 \text{ watts}$ according to EN 60670-24

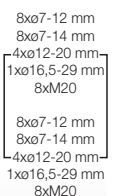
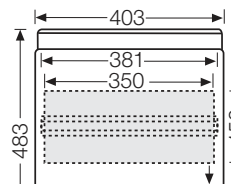

Included blanking strips

**KV small-type distribution boards**

Circuit breaker boxes with additional space for electrical devices not to be manually actuated  
Cable entry via integrated elastic membranes

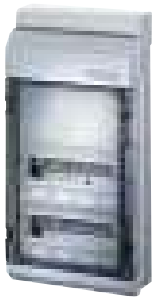

**KV 9330**

**24 modules: 2 x 12 x 18 mm  
without PE and N terminal**

- 2-row
- order PE/N terminals separately
- for the installation of DIN rail equipment, top hat profile 35 mm
- with additional space for electrical devices not to be manually actuated
- with 1 DIN rail, 273 mm wide, for DIN rail equipment and terminal blocks with max. mounting depth 72 mm
- with transparent door
- for door locking device and sealing device refer to accessories
- with cable entry cover
- with blanking strips for unused DIN rail openings
- cable entry via integrated elastic membranes

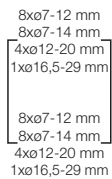
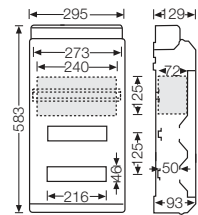

rated insulation voltage	$U_i = 400 \text{ V a.c.}$
power dissipation capability	$P_{de} = 31 \text{ watts}$ according to EN 60670-24
permissible power dissipation	$P_{zul} = 25 \text{ watts at } 30 \text{ K}$ according to DIN 43871



**KV 9440**

**36 modules: 3 x 12 x 18 mm  
without PE and N terminal**

- 3-row
- order PE/N terminals separately
- for the installation of DIN rail equipment, top hat profile 35 mm
- with additional space for electrical devices not to be manually actuated
- with 1 DIN rail, 273 mm wide, for DIN rail equipment and terminal blocks with max. mounting depth 72 mm
- with transparent door
- for door locking device and sealing device refer to accessories
- with cable entry cover
- with blanking strips for unused DIN rail openings
- cable entry via integrated elastic membranes

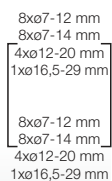
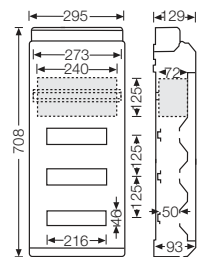

rated insulation voltage	$U_i = 400 \text{ V a.c.}$
power dissipation capability	$P_{de} = 35 \text{ watts}$ according to EN 60670-24
permissible power dissipation	$P_{zul} = 28 \text{ watts at } 30 \text{ K}$ according to DIN 43871

**KV small-type distribution boards**

Circuit breaker boxes with additional space for electrical devices not to be manually actuated  
Cable entry via integrated elastic membranes



**KV 9350**

**36 modules: 2 x 18 x 18 mm  
without PE and N terminal**

- 2-row
- order PE/N terminals separately
- for the installation of DIN rail equipment, top hat profile 35 mm
- with additional space for electrical devices not to be manually actuated
- with 1 DIN rail, 381 mm wide, for DIN rail equipment and terminal blocks with max. mounting depth 72 mm
- with transparent door
- for door locking device and sealing device refer to accessories
- with cable entry cover
- with blanking strips for unused DIN rail openings
- cable entry via integrated elastic membranes

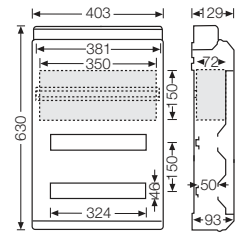

- 8xø7-12 mm
  - 8xø7-14 mm
  - 4xø12-20 mm
  - 1xø16,5-29 mm
  - 8xM20
- 
- 8xø7-12 mm
  - 8xø7-14 mm
  - 4xø12-20 mm
  - 1xø16,5-29 mm
  - 8xM20

rated insulation voltage	$U_i = 400 \text{ V a.c.}$
power dissipation capability	$P_{de} = 38 \text{ watts}$ according to EN 60670-24



Included blanking strips



KV Small-type distribution boards



### **KV small-type distribution boards**

**Circuit breaker boxes with additional space for electrical devices not to be manually actuated**

**Cable entry via metric knockouts**

- Pre-assembly and wiring in the workshop is possible in case of built-in terminal blocks
- Within the same enclosure standard-conforming installation devices (sizes according to DIN 43880) and non-operator-controlled devices can be installed
- Compact user friendly solution, optically optimized by cable entry cover
- Integrated compartment for accessories - everything has its proper place
- DIN-rails with stopper for proper position of installation device
- Screws made of stainless steel V2A
- Cable entry via metric knockouts
- 12 to 36 modules: blanking strips for unused DIN rail openings included
- Burning behaviour: glow wire test in accordance with IEC 60695-2-11: 750 °C, flame-retardant, self-extinguishing
- Colour: grey, RAL 7035

**KV small-type distribution boards**

Circuit breaker boxes with additional space for electrical devices not to be manually actuated  
Cable entry via metric knockouts



**KV 9220 M**

**12 modules: 1 x 12 x 18 mm  
without PE and N terminal**

- 1-row
- order PE/N terminals separately
- for the installation of DIN rail equipment, top hat profile 35 mm
- with additional space for electrical devices not to be manually actuated
- with 1 DIN rail, 273 mm wide, for DIN rail equipment and terminal blocks with max. mounting depth 72 mm
- with transparent door
- for door locking device and sealing device refer to accessories
- with cable entry cover
- with blanking strips for unused DIN rail openings
- knockouts: top and bottom walls 4x M20, 2x M20/25 and 1x M32 each

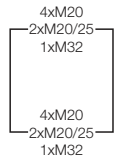
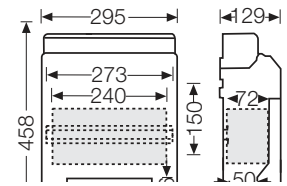

rated insulation voltage	$U_i = 400 \text{ V a.c.}$
power dissipation capability	$P_{de} = 26 \text{ watts}$ according to EN 60670-24
permissible power dissipation	$P_{zul} = 21 \text{ watts at } 30 \text{ K}$ according to DIN 43871



**KV 9230 M**

**18 modules: 1 x 18 x 18 mm  
without PE and N terminal**

- 1-row
- order PE/N terminals separately
- for the installation of DIN rail equipment, top hat profile 35 mm
- with additional space for electrical devices not to be manually actuated
- with 1 DIN rail, 381 mm wide, for DIN rail equipment and terminal blocks with max. mounting depth 72 mm
- with transparent door
- for door locking device and sealing device refer to accessories
- with cable entry cover
- with blanking strips for unused DIN rail openings
- knockouts: top and bottom walls 12x M20, 2x M20/25 and 1x M32 each

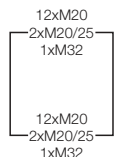
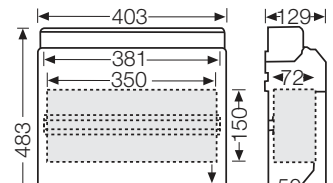

rated insulation voltage	$U_i = 400 \text{ V a.c.}$
power dissipation capability	$P_{de} = 33 \text{ watts}$ according to EN 60670-24



Included blanking strips

**KV small-type distribution boards**

Circuit breaker boxes with additional space for electrical devices not to be manually actuated  
Cable entry via metric knockouts

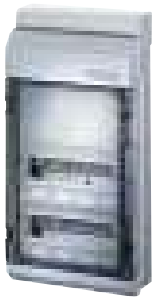

**KV 9330 M**

**24 modules: 2 x 12 x 18 mm  
without PE and N terminal**

- 2-row
- order PE/N terminals separately
- for the installation of DIN rail equipment, top hat profile 35 mm
- with additional space for electrical devices not to be manually actuated
- with 1 DIN rail, 273 mm wide, for DIN rail equipment and terminal blocks with max. mounting depth 72 mm
- with transparent door
- for door locking device and sealing device refer to accessories
- with cable entry cover
- with blanking strips for unused DIN rail openings
- knockouts: top and bottom walls 4x M20, 2x M20/25 and 1x M32 each

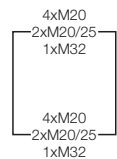
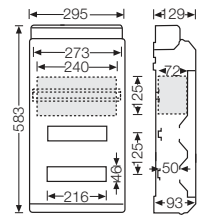

rated insulation voltage	$U_i = 400 \text{ V a.c.}$
power dissipation capability	$P_{de} = 31 \text{ watts}$ according to EN 60670-24
permissible power dissipation	$P_{zul} = 25 \text{ watts at } 30 \text{ K}$ according to DIN 43871



**KV 9440 M**

**36 modules: 3 x 12 x 18 mm  
without PE and N terminal**

- 3-row
- order PE/N terminals separately
- for the installation of DIN rail equipment, top hat profile 35 mm
- with additional space for electrical devices not to be manually actuated
- with 1 DIN rail, 273 mm wide, for DIN rail equipment and terminal blocks with max. mounting depth 72 mm
- with transparent door
- for door locking device and sealing device refer to accessories
- with cable entry cover
- with blanking strips for unused DIN rail openings
- knockouts: top and bottom walls 4x M20, 2x M20/25 and 1x M32 each

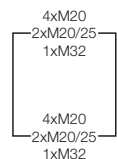
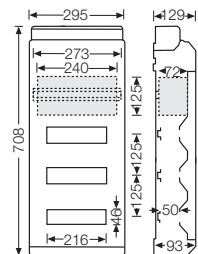

rated insulation voltage	$U_i = 400 \text{ V a.c.}$
power dissipation capability	$P_{de} = 35 \text{ watts}$ according to EN 60670-24
permissible power dissipation	$P_{zul} = 28 \text{ watts at } 30 \text{ K}$ according to DIN 43871

**KV small-type distribution boards**

Circuit breaker boxes with additional space for electrical devices not to be manually actuated  
Cable entry via metric knockouts



**KV 9350 M**

**36 modules: 2 x 18 x 18 mm  
without PE and N terminal**

- 2-row
- order PE/N terminals separately
- for the installation of DIN rail equipment, top hat profile 35 mm
- with additional space for electrical devices not to be manually actuated
- with 1 DIN rail, 381 mm wide, for DIN rail equipment and terminal blocks with max. mounting depth 72 mm
- with transparent door
- for door locking device and sealing device refer to accessories
- with cable entry cover
- with blanking strips for unused DIN rail openings
- knockouts: top and bottom walls 12x M20, 2x M20/25 and 1x M32 each

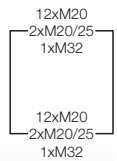
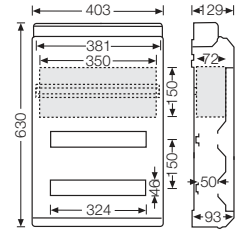

rated insulation voltage	$U_i = 400 \text{ V a.c.}$
power dissipation capability	$P_{de} = 38 \text{ watts}$ according to EN 60670-24



Included blanking strips



**KV small-type distribution boards**

**KV small-type distribution boards**

**Circuit breaker boxes**

**Flanges without knockouts, cable entries can be drilled individually**

- Cable entry via flanges which can be drilled individually
- Compact user friendly solution, optically optimized by cable entry cover
- Integrated compartment for accessories - everything has its proper place
- DIN-rails with stopper for proper position of installation device
- Screws made of stainless steel V2A
- Blanking strips for unused DIN rail openings
- Burning behaviour: glow wire test in accordance with IEC 60695-2-11: 750 °C, flame-retardant, self-extinguishing
- Colour: grey, RAL 7035

**KV small-type distribution boards**  
**Circuit breaker boxes**  
**with flanges for individual drilling of cable entries**



**KV 8112 G**  
**12 modules: 1 x 12 x 18 mm**  
**without PE and N terminal**

- 1-row
- order PE/N terminals separately
- for the installation of DIN rail equipment, top hat profile 35 mm
- with transparent door
- for door locking device and sealing device refer to accessories
- with cable entry cover
- with two flanges which can be drilled individually, closed.  
Useable area 52 mm x 252 mm
- with blanking strips for unused DIN rail openings

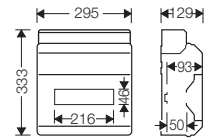

power dissipation capability	$P_{de} = 26$ watts according to EN 60670-24
permissible power dissipation	$P_{zul} = 21$ watts at 30 K according to DIN 43871



**KV 8118 G**  
**18 modules: 1 x 18 x 18 mm**  
**without PE and N terminal**

- 1-row
- order PE/N terminals separately
- for the installation of DIN rail equipment, top hat profile 35 mm
- with transparent door
- for door locking device and sealing device refer to accessories
- with cable entry cover
- with two flanges which can be drilled individually, closed.  
Useable area 52 mm x 252 mm
- with blanking strips for unused DIN rail openings

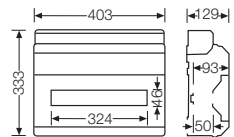

power dissipation capability	$P_{de} = 33$ watts according to EN 60670-24
------------------------------	---



**KV 8224 G**  
**24 modules: 2 x 12 x 18 mm**  
**without PE and N terminal**

- 2-row
- order PE/N terminals separately
- for the installation of DIN rail equipment, top hat profile 35 mm
- with transparent door
- for door locking device and sealing device refer to accessories
- with cable entry cover
- with two flanges which can be drilled individually, closed.  
Useable area 52 mm x 252 mm
- with blanking strips for unused DIN rail openings

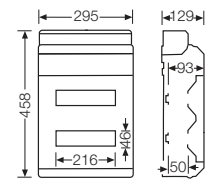

power dissipation capability	$P_{de} = 31$ watts according to EN 60670-24
permissible power dissipation	$P_{zul} = 25$ watts at 30 K according to DIN 43871



Included blanking strips

**KV small-type distribution boards**  
**Circuit breaker boxes**  
**with flanges for individual drilling of cable entries**



**KV 8236 G**  
**36 modules: 2 x 18 x 18 mm**  
**without PE and N terminal**

- 2-row
- order PE/N terminals separately
- for the installation of DIN rail equipment, top hat profile 35 mm
- with transparent door
- for door locking device and sealing device refer to accessories
- with cable entry cover
- with two flanges which can be drilled individually, closed.  
Useable area 52 mm x 252 mm
- with blanking strips for unused DIN rail openings

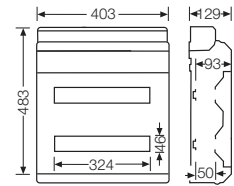

power dissipation capability	$P_{de} = 38$ watts according to EN 60670-24
------------------------------	---



**KV 8448 G**  
**48 modules: 4 x 12 x 18 mm**  
**without PE and N terminal**

- 4-row
- order PE/N terminals separately
- for the installation of DIN rail equipment, top hat profile 35 mm
- with transparent door
- for door locking device and sealing device refer to accessories
- with cable entry cover
- with two flanges which can be drilled individually, closed.  
Useable area 52 mm x 252 mm
- with blanking strips for unused DIN rail openings

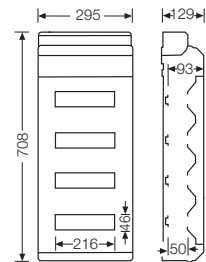

power dissipation capability	$P_{de} = 43$ watts according to EN 60670-24
permissible power dissipation	$P_{zul} = 34$ watts at 30 K according to DIN 43871



Included blanking strips



**KV small-type distribution boards**

**Empty enclosures**

**Cable entry via integrated, elastic membranes**

- Compact user friendly solution, optically optimized by cable entry cover
- DIN-rails with stopper for proper position of installation device
- cable entry via elastic membranes
- Screws made of stainless steel V2A
- Burning behaviour: glow wire test in accordance with IEC 60695-2-11: 750 °C, flame-retardant, self-extinguishing
- Colour: grey, RAL 7035

**KV small-type distribution boards**  
**Empty enclosures**  
**Cable entry via integrated, elastic membranes**



**KV 9331**

**Degree of protection: IP 65**

- for installation of devices via installed mounting plate
- max. installation depth: 160 mm
- thermal power dissipation capability see diagram in the index technical data
- with transparent lid
- fastener for tool operation
- sealable
- with cable entry cover
- cable entry via integrated elastic membranes

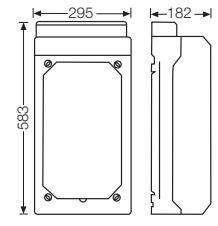

rated insulation voltage	$U_i = 1000 \text{ V a.c.}$
Impact strength	IK 08 (5 Joule)
static load	mounting plate or DIN rail = 9.2 kg lid = 3.2 kg
power dissipation capability at $\Delta\theta = 40 \text{ K}$	$P_{de} = 63 \text{ W}$
relative power dissipation capability in watts per K	$p_{de} = 1.575 \text{ watts per K}$

- 8xØ7-12 mm
  - 8xØ7-14 mm
  - 4xØ12-20 mm
  - 1xØ16,5-29 mm
- 
- 8xØ7-12 mm
  - 8xØ7-14 mm
  - 4xØ12-20 mm
  - 1xØ16,5-29 mm

KV empty box in application





### **KV small-type distribution boards**

#### **Meter box**

#### **Cable entry via integrated elastic membranes**

- Compact user friendly solution, optically optimized by cable entry cover
- DIN-rails with stopper for proper position of installation device
- Sealable
- Screws made of stainless steel V2A
- Burning behaviour: glow wire test in accordance with IEC 60695-2-11: 750 °C, flame-retardant, self-extinguishing
- Colour: grey, RAL 7035

**KV small-type distribution boards**  
**KWH Meter Boxes**  
 cable entry via integrated elastic membranes



**KV 9337**

**Use in areas under control or responsibility of local power supply companies**  
**degree of protection: IP 65**

- with KWH meter support and meter fastening screws for meters with three-point mounting
- max. installation depth: 162 mm
- with hinged flap and protection cover for 12 modules (12 x 18 mm)
- with DIN-rail belonging to it
- with transparent lid
- fasteners for tool operation
- sealable
- with cable entry cover
- cable entry via integrated elastic membranes

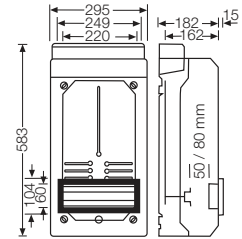

- 8xø7-12 mm
  - 8xø7-14 mm
  - 4xø12-20 mm
  - 1xø16,5-29 mm
- 
- 8xø7-12 mm
  - 8xø7-14 mm
  - 4xø12-20 mm
  - 1xø16,5-29 mm



**KV 9338**

**Use in areas under control or responsibility of local power supply companies**  
**degree of protection: IP 54**

- with KWH meter support and meter fastening screws for meters with three-point mounting
- max. installation depth: 154 mm
- with KWH meter window flap, sealable
- for maximum KWH meters, time switches etc.
- standard opening dimensions 140 x 310 mm
- for tool or manual operation
- for padlock (clip Ø max. 6 mm)
- with additional DIN rail
- length of DIN rail 172 mm
- with transparent lid
- fasteners for tool operation
- sealable
- with cable entry cover
- cable entry via integrated elastic membranes

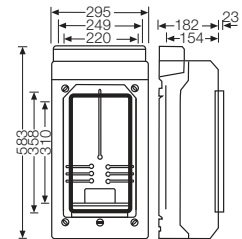

- 8xø7-12 mm
  - 8xø7-14 mm
  - 4xø12-20 mm
  - 1xø16,5-29 mm
- 
- 8xø7-12 mm
  - 8xø7-14 mm
  - 4xø12-20 mm
  - 1xø16,5-29 mm



**KV 9339**

**Use in areas under control or responsibility of local power supply companies**  
**degree of protection: IP 65**

- with KWH meter support and meter fastening screws for meters with three-point mounting
- max. installation depth: 162 mm
- with additional DIN rail
- length of DIN rail 172 mm
- with transparent lid
- fasteners for tool operation
- sealable
- with cable entry cover
- cable entry via integrated elastic membranes

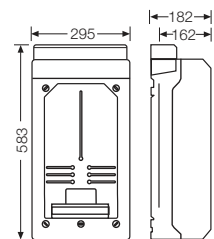

- 8xø7-12 mm
  - 8xø7-14 mm
  - 4xø12-20 mm
  - 1xø16,5-29 mm
- 
- 8xø7-12 mm
  - 8xø7-14 mm
  - 4xø12-20 mm
  - 1xø16,5-29 mm



## **KV small-type distribution boards**

### **Accessories**

Terminals	212 - 213
Labelling system	213
Cable entry covers	214
Locking device, sealing device	215
Spare keys	215
Blanking strip	215



**KV FC 03**

**PE and N terminal**  
**per PE/N 1 x 25 mm<sup>2</sup>, 4 x 4 mm<sup>2</sup> Cu**

- for small-type distribution boards with 3 modules
- FIXCONNECT® plug-in terminal technology, for terminal technology refer to technical data
- current carrying capacity: 101 A

rated insulation voltage	U <sub>i</sub> = 690 V a.c.
--------------------------	-----------------------------



**KV FC 04**

**PE and N terminal**  
**per PE/N 2 x 25 mm<sup>2</sup>, 4 x 4 mm<sup>2</sup>, Cu**

- for small-type distribution boards with 4.5 modules
- FIXCONNECT® plug-in terminal technology, for terminal technology refer to technical data
- current carrying capacity: 101 A

rated insulation voltage	U <sub>i</sub> = 690 V a.c.
--------------------------	-----------------------------



**KV FC 06**

**PE and N terminal**  
**per PE/N 2 x 25 mm<sup>2</sup>, 4 x 4 mm<sup>2</sup>, Cu**

- for small-type distribution boards with 6 modules
- FIXCONNECT® plug-in terminal technology, for terminal technology refer to technical data
- current carrying capacity: 101 A

rated insulation voltage	U <sub>i</sub> = 690 V a.c.
--------------------------	-----------------------------



**KV FC 09**

**PE and N terminal**  
**PE/N 2 x 25 mm<sup>2</sup>, 8 x 4 mm<sup>2</sup>, Cu each**

- for small-type distribution boards with 9 modules
- FIXCONNECT® plug-in terminal technology, for terminal technology refer to technical data
- current carrying capacity: 101 A

rated insulation voltage	U <sub>i</sub> = 690 V a.c.
--------------------------	-----------------------------



**KV FC 12**

**PE and N terminal**  
**per PE/N 3 x 25 mm<sup>2</sup>, 12 x 4 mm<sup>2</sup>, Cu**

- for small-type distribution boards with 12 modules and KV empty boxes
- FIXCONNECT® plug-in terminal technology, for terminal technology refer to technical data
- N separable, for up to 2 different potentials
- current carrying capacity: 75 A

rated insulation voltage	U <sub>i</sub> = 690 V a.c.
--------------------------	-----------------------------



**KV FC 18**

**PE and N terminal**  
**per PE/N 4 x 25 mm<sup>2</sup>, 16 x 4 mm<sup>2</sup>, Cu**

- for small-type distribution boards with 18 modules per row
- FIXCONNECT® plug-in terminal technology, for terminal technology refer to technical data
- N separable, for up to 2 different potentials
- current carrying capacity: 75 A

rated insulation voltage

U<sub>i</sub> = 690 V a.c.



**KV FC 24**

**PE and N terminal**  
**per PE/N 6 x 25 mm<sup>2</sup>, 24 x 4 mm<sup>2</sup>, Cu**

- for small-type distribution boards with 12 modules and KV empty boxes
- FIXCONNECT® plug-in terminal technology, for terminal technology refer to technical data
- N separable, up to 4 different potentials
- current carrying capacity: 75 A

rated insulation voltage

U<sub>i</sub> = 690 V a.c.



**KV FC 36**

**PE and N terminal**  
**per PE/N 8 x 25 mm<sup>2</sup>, 32 x 4 mm<sup>2</sup>, Cu**

- for small-type distribution boards with 18 modules per row
- FIXCONNECT® plug-in terminal technology, for terminal technology refer to technical data
- N separable, up to 4 different potentials
- current carrying capacity: 75 A

rated insulation voltage

U<sub>i</sub> = 690 V a.c.



**FC BS 5**

**FIXCONNECT labelling system**  
**set with 5 pieces**

- labelling system for FIXCONNECT® plug-in terminals, not for terminals 2x25 / 4x4 mm<sup>2</sup>
- for attaching of labelling strips or marking with felt tip pen



**FC BS 6**

**FIXCONNECT labelling system**  
**set with 5 pieces**

- labelling system for FIXCONNECT® plug-in terminals, for terminals 2x25 / 4x4 mm<sup>2</sup>
- for attaching of labelling strips or marking with felt tip pen

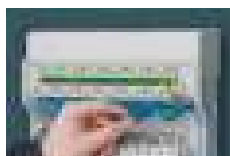

FIXCONNECT® plug-in terminal technology



**KV EB 03**

**Cable entry cover**

- for small-type distribution boards with 3 modules
- for replacement purposes  
(1 cable entry cover included with supply of the board)



**KV EB 04**

**Cable entry cover**

- for small-type distribution boards with 4.5 modules
- for replacement purposes  
(1 cable entry cover included with supply of the board)



**KV EB 06**

**Cable entry cover**

- for small-type distribution boards with 6 modules
- for replacement purposes  
(1 cable entry cover included with supply of the board)



**KV EB 09**

**Cable entry cover**

- for small-type distribution boards with 9 modules
- and for KV 9325, KV 9363
- for replacement purposes  
(1 cable entry cover included with supply of the board)



**KV EB 12**

**Cable entry cover**

- for small-type distribution boards with 12 modules per row
- only order additionally if the cable entry should be covered at the top and bottom  
(1 cable entry cover included with supply of the board)



**KV EB 18**

**Cable entry cover**

- for small-type distribution boards with 18 modules per row
- only order additionally if the cable entry should be covered at the top and bottom  
(1 cable entry cover included with supply of the board)



**KV EB 26**

**Cable entry cover**

- for small-type distribution boards KV 0112, KV 0212, KV 0124, KV 0224, KV 0136, KV 0236
- only order additionally if the cable entry should be covered at the top and bottom  
(1 cable entry cover included with supply of the board)

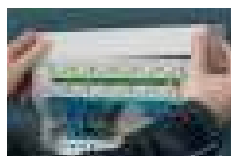

Compact user friendly solution, optically optimized by cable entry cover



**KV ES 1**

**Locking device  
for small-type distribution boards 12 - 54 modules**

- profile cylinder with 2 keys



**KV ES 2**

**Spare key**

- for door lock KV ES 1 or KV ES 3
- 2 pieces



**KV ES 3**

**Locking device  
for small-type distribution boards 3 - 9 modules**

- and for KV 9325, KV 9363
- profile cylinder with 2 keys



**KV PL 2**

**Sealing device  
for small-type distribution boards 12 - 54 modules**

- for sealing the top and bottom parts of the box  
(doors can be sealed without accessories)



**KV PL 3**

**Sealing device  
for small-type distribution boards 3 - 9 modules**

- and for KV 9325, KV 9363
- for sealing the top and bottom parts of the box  
(doors can be sealed without accessories)



**AS 12**

**Blanking strip  
12 modules**

- 12 x 18 mm, divisible every 9 mm
- for the covering of spare equipment openings,  
for material thickness up to 3 mm



**AS 18**

**Blanking strip  
18 modules**

- 18 X 18 mm, divisible every 9 mm
- for the covering of spare equipment openings,  
for material thickness up to 3 mm



Sealing of top and bottom part



Blanking strips for unused DIN rail openings



## **KV small-type distribution boards**

### **Technical details**

Mounting dimensions in mm	217 -218
Lateral box assembly	219
Terminals	220 - 221
Standards	221
Permissible power dissipation	221
Operating and ambient conditions	222

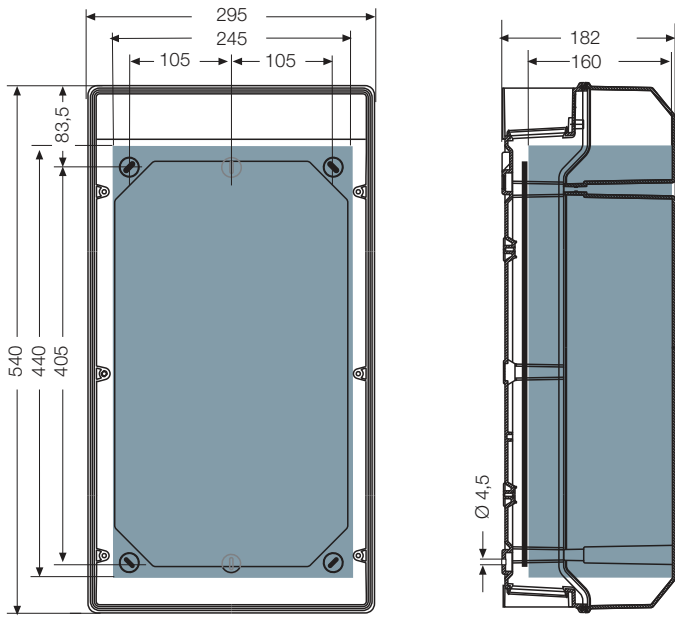

KV 9331

 = usable installation area with mounted cable glands

Wall mounting for screws up to 4.5 mm diameter.

Circuit breaker boxes  
3 modules

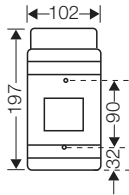

Circuit breaker boxes  
4.5 modules

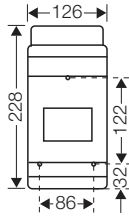

Circuit breaker boxes  
6 modules

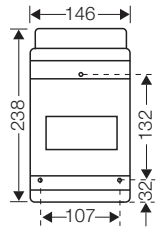

Circuit breaker boxes  
9 modules

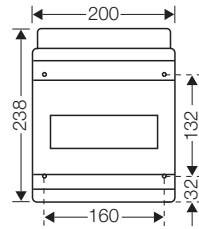

Circuit breaker boxes  
12 modules

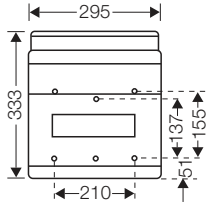

Circuit breaker boxes  
2 x 12 modules

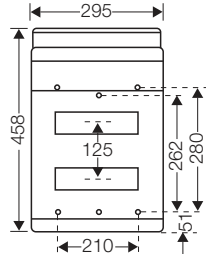

Circuit breaker boxes  
3 x 12 modules

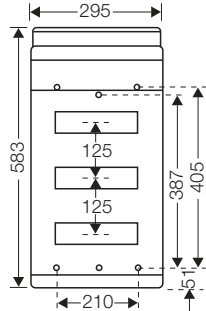

Circuit breaker boxes  
4 x 12 modules

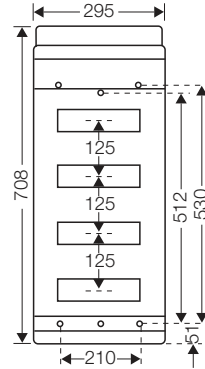

Circuit breaker boxes  
1 x 18 modules

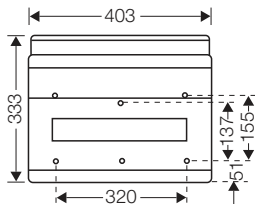

Circuit breaker boxes  
2 x 18 modules

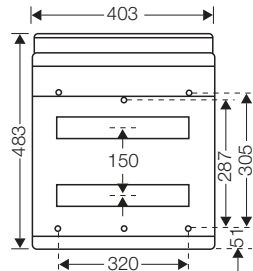

Circuit breaker boxes  
3 x 18 modules

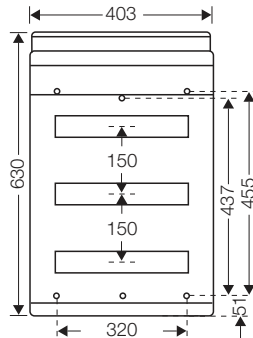

By turning the rail by 180°, the assembly depth under the protection cover can be increased to 59 mm. No additional components are required.

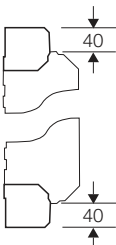

Cable entry cover for KV Circuit breaker boxes IP 54 and IP 65 with 12-54 modules mounted on top and the bottom.

**Technical details**  
**Lateral box assembly**

**KV Circuit breaker boxes can be assembled laterally as shown below:**

- in degree of protection IP 65 with threaded connecting glands AVS 16
- in degree of protection IP 54 with press-in connecting glands EVS 16

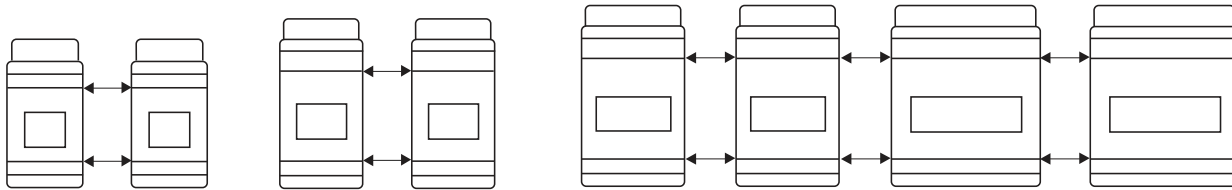

KV Circuit breaker boxes 3 modules      KV Circuit breaker boxes 4.5 modules      KV Circuit breaker boxes 6 modules      KV Circuit breaker boxes 9 modules

**KV Circuit breaker / Meter and Empty boxes can be assembled laterally as shown below:**

- in degree of protection IP 65 with threaded connecting glands AVS 16
- in degree of protection IP 54 with press-in connecting glands EVS 16

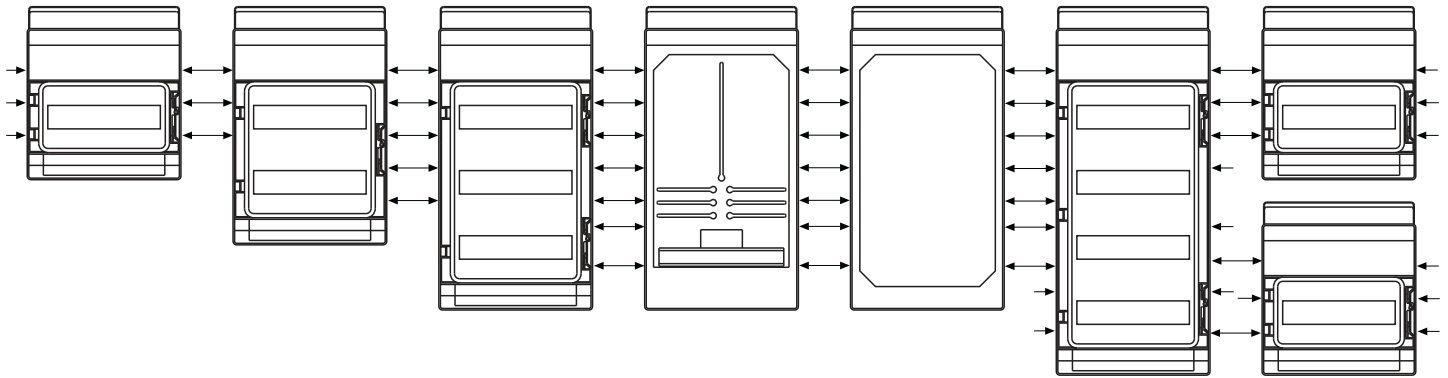

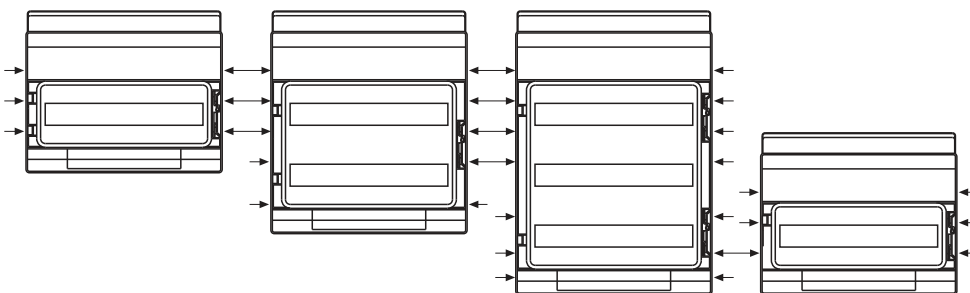

KV circuit breaker boxes 12 modules      KV circuit breaker boxes 2x12 modules, KV 9220, KV 9220 M      KV circuit breaker boxes 3x12 modules, KV 9330, KV 9330 M      KWH Meter boxes KV 9338, KV 9337      KV empty box 4x12 modules KV 9440, KV 9440 M      KV empty box 4x12 modules KV 9440, KV 9440 M      KV circuit breaker boxes 12 modules



KV circuit breaker boxes 18 modules      KV circuit breaker boxes 2 x 18 modules, KV 9230, KV 9230 M      KV circuit breaker boxes 3 x 18 modules, KV 9350, KV 9350 M      KV circuit breaker boxes 18 modules

**PE and N FIXCONNECT® terminal**

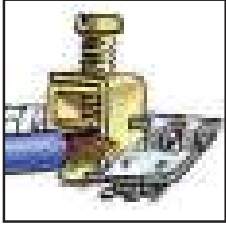
**Rated connecting capacity of PE and N terminals for copper conductors**

Clamping unit	Corresponding cross-sections/copper				
	max. number	from - to max.		max. number	from - to max.
Screw-type terminal 25 mm <sup>2</sup>					
	1	25 mm <sup>2</sup> , s	Tested as connecting terminal for several conductors of the same cross-sections for using in one circuit	1	25 mm <sup>2</sup> , f
	1	16 mm <sup>2</sup> , s		1	16 mm <sup>2</sup> , f
	1	10 mm <sup>2</sup> , sol		1	10 mm <sup>2</sup> , f
	3	6 mm <sup>2</sup> , sol		1	6 mm <sup>2</sup> , f
	3	4 mm <sup>2</sup> , sol		1	4 mm <sup>2</sup> , f
	4	2.5 mm <sup>2</sup> , sol		1	2.5 mm <sup>2</sup> , f
	4	1.5 mm <sup>2</sup> , sol		1	1.5 mm <sup>2</sup> , f
Plug-in terminal 4 mm <sup>2</sup>					
	1	1.5 - 4 mm <sup>2</sup> , sol		1	1.5 - 4 mm <sup>2</sup> , f
					Without end ferrule; clamping unit has to be opened with a tool when conductor is inserted

















**Current carrying capacity of the connecting device: 75 A**

All terminals are secured against self loosening.















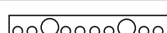

Technical details  
Terminals

Terminal equipment and number of conductors to be connected

PE terminal for copper conductors

Number of modules	PE terminal	
	 up to 4 mm <sup>2</sup>	 up to 25 mm <sup>2</sup>
3	 4x4 mm <sup>2</sup>	 1x25 mm <sup>2</sup>
4.5 6	 4x4 mm <sup>2</sup>	 2x25 mm <sup>2</sup>
9	 8x4 mm <sup>2</sup>	 2x25 mm <sup>2</sup>
12	 12x4 mm <sup>2</sup>	 2x25 mm <sup>2</sup>
18	 16x4 mm <sup>2</sup>	 4x25 mm <sup>2</sup>
24 36 (3-row) 48	 24x4 mm <sup>2</sup>	 6x25 mm <sup>2</sup>
36 (2-row) 54	 32x4 mm <sup>2</sup>	 8x25 mm <sup>2</sup>

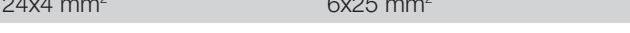
N terminal for copper conductors

Number of modules	N terminal		
	 up to 4 mm <sup>2</sup>	 up to 25 mm <sup>2</sup>	 plug-in jumper
3	 4x4 mm <sup>2</sup>	 1x25 mm <sup>2</sup>	
4.5 6	 4x4 mm <sup>2</sup>	 2x25 mm <sup>2</sup>	
9	 8x4 mm <sup>2</sup>	 2x25 mm <sup>2</sup>	
12	 12x4 mm <sup>2</sup>	 2x25 mm <sup>2</sup>	
18	 16x4 mm <sup>2</sup>	 4x25 mm <sup>2</sup>	
24 36 (3-row) 48	 24x4 mm <sup>2</sup>	 6x25 mm <sup>2</sup>	
36 (2-row) 54	 32x4 mm <sup>2</sup>	 8x25 mm <sup>2</sup>	

**Standards and regulations**

- DIN EN 60670-24: Particular requirements for enclosures for housing protective devices and other power dissipating electrical equipment
- DIN 43880  
 Built-in equipment for electrical installations; overall dimensions and related mounting dimensions
- IEC 60 999, Connecting devices  
 Safety requirements for screw-type and screwless-type clamping units for electrical copper conductors
- EN 60 529 / DIN VDE 0470 Part 1  
 Degrees of protection provided by enclosures (IP-Code)

**Table 4: Permissible power dissipation for distribution boards**

Table 4					
Permissible power dissipation $P_{zul}$ for distribution boards for wall-mounting at overtemperature $\Delta T$					
size	10 K	15 K	20 K	25 K	30 K
1-row	5.5 W	9.0 W	12.5 W	16.5 W	21.0 W
2-row	6.5 W	11.0 W	15.0 W	20.0 W	25.0 W
3-row	7.0 W	12.0 W	17.0 W	22.0 W	28.0 W
4-row	8.5 W	14.5 W	20.5 W	27.0 W	34.0 W

**Temperature rise ( $\Delta\theta$ ) of empty enclosure KV 9331 caused by power dissipation of electrical devices**

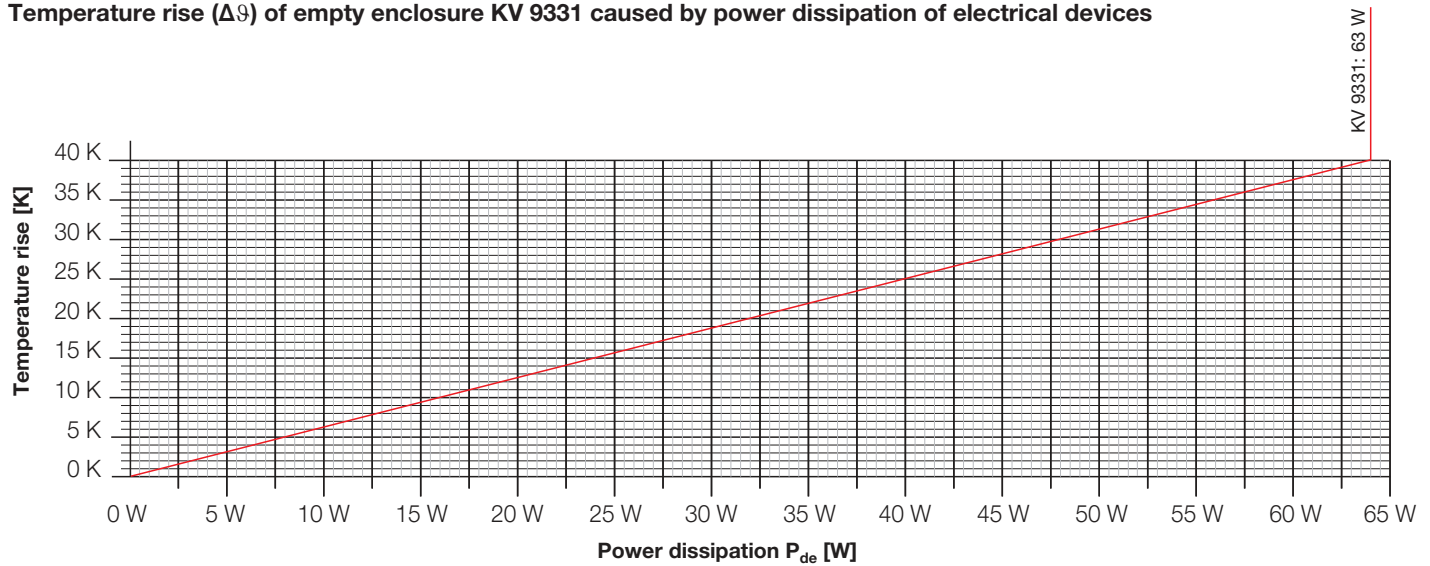

	KV Small-type distribution boards PS polystyrene		KV PC Small-type distribution boards PC polycarbonate
	<b>KV Small-type distribution boards and KWH Meter boxes</b>	<b>Empty boxes</b>	<b>KV PC Small-type distribution boards</b>
<b>Application area</b>	<b>Degree of protection IP 54/65:</b> Suitable for indoor installation and outdoor installation, protected against weather influences: However, pay attention to the climatic effects on the installed equipment, for example, high or low ambient temperatures or formation of condensed water see technical information		The enclosures are suitable for outdoor installation - harsh environment and / or outdoor. The material is examined for UV resistance by the institute for plastics and thereby suitable for the outdoor installation during UV effect. However the climatic influences and effects on the equipment are to be considered.
<b>Ambient temperature</b>			
- Average value over 24 hours	+ 35 °C	-	+ 35 °C
- Maximum value	+ 40 °C	+ 60 °C	+ 40 °C
- Minimum value	- 5 °C	- 25 °C	- 5 °C
<b>Relative humidity</b>	50% at 40 °C	-	-
- short-time	100% at 25 °C	-	-
<b>Fire protection</b> in the case of internal faults	Demands placed on electrical devices from standards and laws:  Minimum requirements - Glow wire test in accordance with IEC 60 695-2-11: - 650 °C for boxes and cable glands - 850 °C for parts of insulating material necessary to retain current carrying parts in position		
<b>Burning behaviour</b>			
- Glow wire test IEC 60 695-2-11	750 °C	750 °C	960 °C
- UL Subject 94	V-2 flame-retardant self-extinguishing	V-2 flame-retardant self-extinguishing	V-2 flame-retardant self-extinguishing
<b>Degree of protection against mechanical load</b>	IK08 (5 Joule)	IK08 (5 Joule)	IK08 (5 Joule)
<b>Toxic behaviour</b>	halogen-free silicone-free	halogen-free silicone-free	halogen-free silicone-free

"Halogen-free" in accordance with IEC 60754-2 "Common test methods for cables - Determination of the amount of halogen acid gas".

**For material properties see technical data.**



## **ENYSTAR** **Distribution boards up to 250 A**

with door, in accordance with IEC 61439-3

- combinable enclosure system
- degree of protection: IP 66
- made from polycarbonate
- protection class II, □

IEC 61439-3: Interface characteristics of an assembly	226 - 227
System description / System design	228 - 233
Overview product range	234 - 235
<b>Empty enclosures</b>	
Door locking with hand-operation	236 - 242
Door locking with tool-operation	243 - 248
<b>Circuit breaker boxes</b>	
for the installation of DIN rail equipment <b>up to 63 A</b> according to DIN 43880, with PE- and N terminals, 9 up to 54 modules	249 - 253
for miniature circuit breakers (MCB)	253
without PE- and N terminals, 12 up to 54 modules	254 - 259
<b>Circuit breaker boxes</b>	
for the installation of DIN rail equipment <b>up to 100 A</b> according to DIN 43880, without PE- and N terminals, 12 up to 54 modules,	260 - 261
for miniature circuit breakers (MCB)	261
terminal box	262
Accessories	263 - 281
Technical details	282 - 297

Further technical information can be found on the Internet  
[www.hensel-electric.de](http://www.hensel-electric.de) -> Products

**Standard-conforming rating of distribution boards**

The IEC 61439 - the standard for the construction of switchgear assemblies - brings changes that affect the planning of a switchgear assembly. In addition, new tasks and responsibilities are awaiting the manufacturer of a switchgear assembly.

Decisive for the optimal functioning of a switchgear assembly under operating conditions is the correct rating of the interface characteristics of the assembly. For this purpose, the assembly is considered as **BLACK-BOX** with four interface characteristics which shall ensure compatibility with the ratings of the circuits to which it is connected and the installation conditions and shall be declared by the assembly manufacturer using the criteria identified below.

**Assembly considered as BLACK BOX with the four interface characteristics according to IEC 61439-2, -3**



**Installation and ambient conditions**

- For protected outdoor installation
- Degree of protection IP 66
- Combinable enclosure system, extendable in all directions
- 4 enclosure sizes in grid of 90 mm
- EMC compliant busbar system
- Wall-mounting



**Operation and maintenance**

- Distribution board up to 250 A intended to be operated by ordinary persons in accordance with IEC 61439-3
- Protection class II up to rated current of 250 A
- Flexible through standardised and tested kits
- Spacious connection areas
- Fulfill the requirements for operation by ordinary persons (DBO)

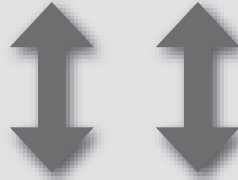

**BLACK BOX with 4 interfaces**



**ENYSTAR Distribution Board**

Combinable enclosure system, insulation-enclosed, total insulated, degree of protection IP 66, **for the assembly of ENYSTAR distribution boards up to 250 A intended to be operated by ordinary persons (DBO) in accordance with IEC 61439-3**

The requirements for all installed electrical functions within the assembly have been proved compliance with the applicable requirements of IEC 61439-3.

$I_{nc}$  and RDF must be specified in the documentation.

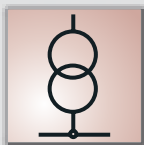

**Connection to the electrical network**

- Electric circuit / final circuit
- Circuit-breaker up to 250 A
- Switch disconnector up to 250 A
- Fuse switch disconnector up to 250 A
- Bus-mounted fuse base up to 63 A
- Cable connection from top / from bottom
- Connection: conductors from copper / aluminum
- Optional connection of CEE sockets according to EN 60309 and sockets with earthing contact according to DIN 49440-1

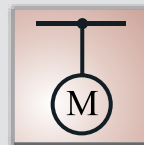

**Circuits and consumers**

- Rated voltage  $U_N = 690$  V a.c. / 1000 V d.c.
- Rated current  $I_N$  up to 250 A
- Circuit-breaker up to 250 A
- Switch disconnector up to 250 A
- Fuse switch disconnector up to 250 A
- 5-conductor systems
- Cable connection from top / from bottom

**Changes facing the manufacturer of a switchgear assembly (Panel builder)**

IEC 61439 - the standard for the assembly of switchgear assemblies and distribution boards - determines the safety requirements for electrical equipment for the compliance of protection objectives for people and facilities. Requirements for products are more clearly defined and a new terminology is introduced.

**BLACK BOX Specification**

The designer specifies a switchgear assembly by defining the interface parameters as BLACK BOX. Based on these interface specifications the manufacturer of a switchgear assembly has to rate and define the structure of the switchgear assembly.

**Product presentation in media changed significantly**

The standard has an effect as well on the documentation of products. Additional information, such as the rated current of circuits and the number of circuits, are now listed for each product as they are now required by designers and manufacturers for the construction of switchgear assemblies.

The international catalogue presents ENYSTAR empty and circuit breaker boxes.

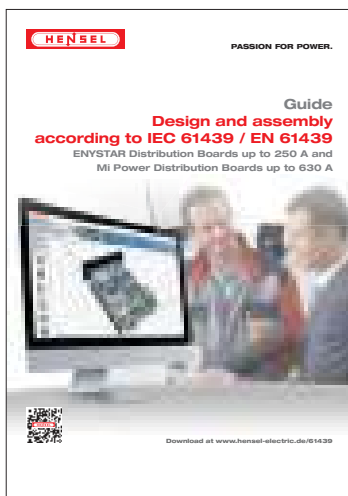

Further enclosures with electrical functions for the assembly of ENYSTAR distribution boards up to 250 A, for example, with built-in busbars, circuit breakers, etc., see at: [www.hensel-electric.de](http://www.hensel-electric.de)

**For design and assembly according IEC 61439 / EN 61439 with ENYSTAR Distribution Boards up to 250 A please refer to the guide at [www.hensel-elctric.de/61439](http://www.hensel-elctric.de/61439).**

The guide to design and assemble in accordance with EN 61439 for ENYSTAR distribution boards up to 250 A and Mi Power distribution boards up to 630 A can be downloaded:



[www.hensel-electric.de/en](http://www.hensel-electric.de/en)

**ENYGUIDE****Planning tool Configurator ENYGUIDE at [www.enyguide.eu](http://www.enyguide.eu)**

Free planning software ENYGUIDE: allows the quick and easy configuration of distribution boards.



- Dimensional drawings and parts lists are automatically created by ENYGUIDE.
- Representation of the distribution board as a detailed 3D-image or a 2D-drawing.
- Various view planes show the equipment, covers and doors.
- ENYGUIDE determines the necessary accessories such as the number of wall separators independently.
- No time-consuming program installation is needed.

[www.enyguide.eu](http://www.enyguide.eu)

**Distribution boards up to 250 A with door**

combinable enclosure system, insulation-enclosed, degree of protection IP 66, made from polycarbonate, for the assembly of distribution boards up to 250 A, intended to be operated by ordinary persons in accordance with IEC 61439-3

- for indoor and protected outdoor installation
- dust-proof and protected against water (IP 66)
- protection class II 
- colour: grey, RAL 7035

**Material: Polycarbonate**

- Burning behaviour: Glow wire test according to IEC 60695-2-11, self-extinguishing, flame-retardant
- UV resistant according to IEC 61439-1, Section 10.2.4: The material is examined for UV resistance
- Toxic behaviour: silikon- and halogen-free
- Chemical resistance: Resistant against acid 10 % and alkaline 10 %, petrol and mineral oil

ENYSTAR®  
Distribution boards

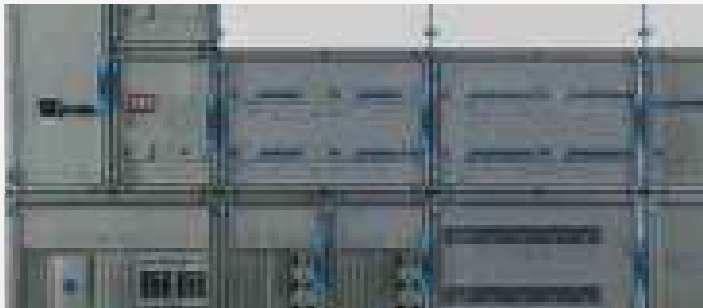

Combinable enclosure system with doors



Easy operation of the devices behind a door with protection against accidental contact.



Quick assembly



Assembling ENYSTAR distribution boards according to IEC 61439-3

**Doors**

- all enclosure sizes with door
- transparent and opaque
- door hinge changeable
- sealable
- locking facilities: lockable, door fasteners for tool and hand operation
- operation of the devices behind the door protected with covers
- no overhangig handles

**Quick Assembly**

- closed or open enclosure walls, which can fast and easily be closed with closing plate sets
- integrated gaskets
- safe connectors

**Pre-assembled enclosures with electrical functions**

- Protection covers in enclosures with electrical functions
- Connection Box for the installation of devices that must be operated externally, such as plug devices, push buttons and switches
- Cable entry via flanges up to cable diameter of 72 mm

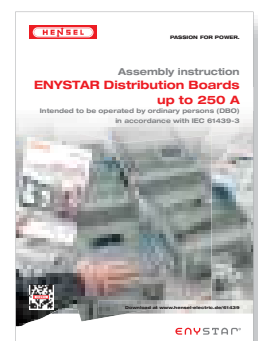

**Assembly instruction**

Please request or download information:  
[www.hensel-electric.de/en](http://www.hensel-electric.de/en) -> Downloads

# Dependent on the system

## Electrical parameters



### Electrical parameters

rated voltage: max. 690 V a.c.  
 rated insulation voltage: 690 V a.c., 1000 V d.c.  
 rated current: max. 250 A  
 rated short-time withstand current: max. 13 kA

**The design values are possibly reduced by the installed equipment technology, please refer to technical data of the product or index technical data.**

## System properties

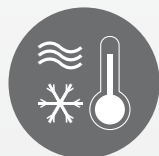

### Environmental conditions

Ambient temperature  
 - for distribution boards in accordance with IEC 61439-3: -5 °C up to 35 °C, max. + 40 °C  
 Relative humidity: 50% at 40 °C, 100% at 25 °C  
 - for empty enclosures: - 25 °C up to + 70 °C  
 The climatic influences and effects on the equipment are to be considered, see technical details / operating and ambient conditions



### Application area

**The enclosures are suitable for outdoor installation, protected against weather influences.**  
 However, pay attention to the climatic effects on the installed equipment, see operating and ambient conditions in index technical data.



### Insulation

insulated enclosures (protection class II) 



### Impact strength

degree of protection against mechanical load IK 08 (5 Joule) in accordance with IEC 62262



### Protection against foreign solid objects and direct contact

dust-proof degree of protection IP 66



### Protection against ingress of water with harmful effects

protected against water degree of protection IP 66

# Dependent on material

## Material properties: polycarbonate



### Burning behaviour

glow wire test 960 °C  
 in accordance with IEC 60695-2-11  
 flame-retardant, self-extinguishing



### UV resistance

UV resistance according to IEC 61439-1, Section 10.2.4: the material is examined for UV resistance



### Chemical resistance

resistance against acid 10% and alkaline 10%, petrol and mineral oil

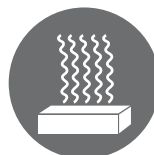

### Toxic behaviour

silicone- and halogen-free

**Distribution board with door**

- combinable
- modular structure of enclosures in grid of 90 mm
- 4 enclosure sizes: 270 x 180 mm, 270 x 360 mm, 270 x 540 mm and 540 x 360 mm
- for the assembly of distribution boards up to 250 A
- all enclosures can also be used as single enclosures

**Combinable enclosures with door and closing plates**

- 4 box sizes: 276 x 186 mm, 276 x 366 mm, 276 x 546 mm and 546 x 366 mm

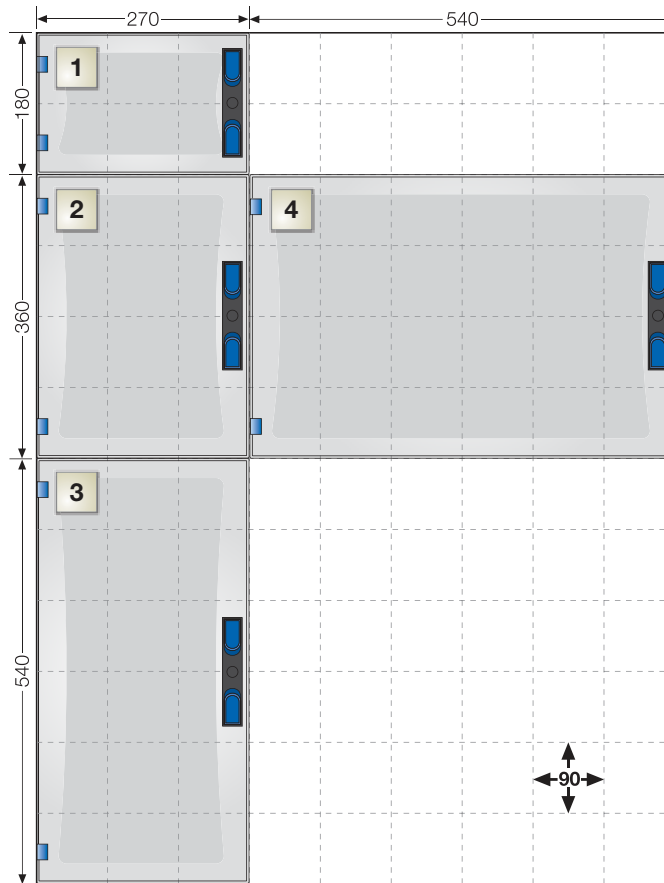

**Enclosure depth with hand operation**

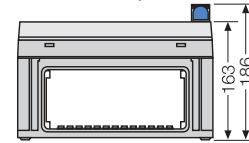

**with tool operation**

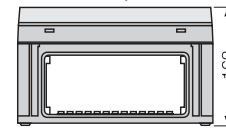

**Extension frame for extending installation depths by 50 mm with hand operation**

for extending installation depths by 50 mm with hand operation

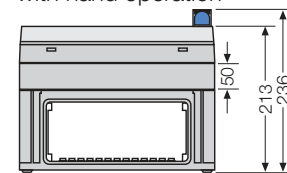

**with tool operation**

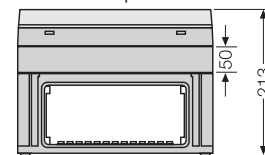

ENYSTAR® Distribution boards

ENYSTAR distributors are highly adaptable in confined spaces and therefore well suited for industrial and commercial buildings:

- modular,
- with high degree of protection,
- expandable in all directions (vertical and horizontal).

Extension frames allow the installation of devices with different installation heights.



**Transparent covers:**

All electrical functions at a glance. Errors can be instantly localized. The current course is always visible from the outside in the event of a fault or for retrofitting.

**Flexible and expandable**

even in case of retrofitting additional circuits. Depending on the number of additional required circuits matching enclosure sizes are available. They can be combined horizontally or vertically on each enclosure wall.

**Electrical safety, dimensional stability**

In an impact or any other mechanical stress ENYSTAR enclosures gradually buffer and spring immediately back to the original shape. A temporarily contact with live parts does not cause a short-circuit. The protection against electric shock is maintained.

Combinable distribution boards with door



Empty enclosures door locking with **hand operation**  
**Operation and access also by unskilled persons**

Empty enclosures door locking with **tool operation**  
**Access and operation only by skilled persons**

Circuit breaker boxes



- Hand-operated locking facilities in areas, where electrotechnical unskilled persons operate equipment



- Locking option with key prevents unauthorized access

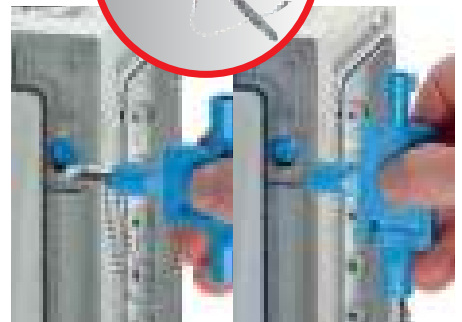
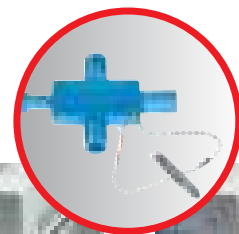

- Multikey for door locking systems: Standard locking system for tool-operation with slot screwdriver and triangle 8 mm, optional square lock 8 mm and double-bit.

Combinable enclosures with door and closing plates

Empty enclosures and circuit breaker boxes additionally with closing plate sets for closing enclosure walls



Enclosure walls closed via closing plates

Flanges to be ordered separately



**Can be combined and extended in all directions**

Because of the increasing requirements, flexibility is essential in the electrical installation.

ENYSTAR enclosures can be combined and arranged freely in

order to adapt the system flexibly to the individual requirements in site:

**Combination next to each other or one above the other.**

Large doors for all box sizes allow a simple accessibility of the electrical functions.



Combination of enclosures in **vertical** direction.



Combination of enclosures in **horizontal** direction.



**Distribution boards intended to be operated by ordinary persons**

Example 1:  
Distribution board with 72 modules (6 x 12 x 18 mm) built-up of 2 x FP 1318 with closing plates

Example 2:  
Distribution board with 125 A feeding, 36 modules (3 x 12 x 18 mm) and a terminal box for PE and N

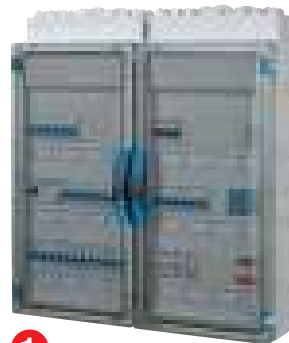

**ENYSTAR®**  
**Connection Box**

The ENYSTAR Connection Box allows a simple and fast installation of devices that must be operated externally. Such as plug devices, pushbuttons, switches or also touch panels.

The new Connection Box is installed via safe plug connectors.

The ENYSTAR Connection Box is available in different designs and standard equipments.





**Empty enclosures**  
hand-operated door lockings

with transparent doors      with opaque doors

**Empty enclosures**  
tool-operated door lockings

with transparent doors      with opaque doors

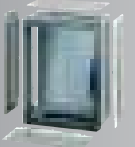
ENYSTAR®  
Distribution boards

	<b>FP 0140</b> built-in dimensions 216x126x140 mm		<b>FP 0150</b> built-in dimensions 216x126x140 mm
	<b>FP 0141</b> built-in dimensions 216x126x140 mm with closing plates		<b>FP 0151</b> built-in dimensions 216x126x140 mm with closing plates
	<b>FP 0240</b> built-in dimensions 216x306x140 mm		<b>FP 0250</b> built-in dimensions 216x306x140 mm
	<b>FP 0241</b> built-in dimensions 216x306x140 mm with closing plates		<b>FP 0251</b> built-in dimensions 216x306x140 mm with closing plates
	<b>FP 0340</b> built-in dimensions 216x486x140 mm		<b>FP 0350</b> built-in dimensions 216x486x140 mm
	<b>FP 0341</b> built-in dimensions 216x486x140 mm with closing plates		<b>FP 0351</b> built-in dimensions 216x486x140 mm with closing plates
	<b>FP 0440</b> built-in dimensions 486x306x140 mm		<b>FP 0450</b> built-in dimensions 486x306x140 mm
	<b>FP 0441</b> built-in dimensions 486x306x140 mm with closing plates		<b>FP 0451</b> built-in dimensions 486x306x140 mm with closing plates
	<b>FP 0461</b> built-in dimensions 306x486x140 mm with closing plates		<b>FP 0471</b> built-in dimensions 306x486x140 mm with closing plates

	<b>FP 0100</b> built-in dimensions 216x126x140 mm		<b>FP 0120</b> built-in dimensions 216x126x140 mm
	<b>FP 0101</b> built-in dimensions 216x126x140 mm with closing plates		<b>FP 0121</b> built-in dimensions 216x126x140 mm with closing plates
	<b>FP 0210</b> built-in dimensions 216x306x140 mm		<b>FP 0230</b> built-in dimensions 216x306x140 mm
	<b>FP 0211</b> built-in dimensions 216x306x140 mm with closing plates		<b>FP 0231</b> built-in dimensions 216x306x140 mm with closing plates
	<b>FP 0310</b> built-in dimensions 216x486x140 mm		<b>FP 0330</b> built-in dimensions 216x486x140 mm with closing plates
	<b>FP 0311</b> built-in dimensions 216x486x140 mm with closing plates		<b>FP 0331</b> built-in dimensions 216x486x140 mm with closing plates
	<b>FP 0400</b> built-in dimensions 486x306x140 mm		<b>FP 0420</b> built-in dimensions 486x306x140 mm
	<b>FP 0401</b> built-in dimensions 486x306x140 mm with closing plates		<b>FP 0421</b> built-in dimensions 486x306x140 mm with closing plates
	<b>FP 0411</b> built-in dimensions 306x486x140 mm with closing plates		<b>FP 0431</b> built-in dimensions 306x486x140 mm with closing plates

**Built-in equipment must be suitable for operation by electrotechnical unskilled persons and has to be protected by a cover against direct contact with hazardous life parts.**

Empty boxes for the installation of different electrical devices either directly over attachments in the bottom or on DIN rails or mounting plates.

Empty boxes for the installation of different electrical devices either directly over attachments in the bottom or on DIN rails or mounting plates.

**Circuit breaker boxes with PE/N**

for DIN rail equipment up to 63 A















**without PE/N**

for DIN rail equipment up to 63 A















**Circuit breaker boxes without PE/N terminals**

for DIN rail equipment up to 63 A, with removable DIN rail rack and earth connection

for DIN rail equipment up to 100 A

	<b>FP 1109</b> 1x9x18 mm		<b>FP 1105</b> 1x12x18 mm with closing plates
	<b>FP 1108</b> 1x9x18 mm with closing plates		<b>FP 1215</b> 2x12x18 mm with closing plates
	<b>FP 1219</b> 2x12x18 mm		<b>FP 1315</b> 3x12x18 mm with closing plates
	<b>FP 1218</b> 2x12x18 mm with closing plates		<b>FP 1415</b> 3x17x18 mm with closing plates
	<b>FP 1319</b> 3x12x18 mm		
	<b>FP 1318</b> 3x12x18 mm with closing plates		
	<b>FP 1409</b> 2x27x18 mm with closing plates		
	<b>FP 1408</b> 2x27x18 mm with closing plates		
	<b>FP 1418</b> 3x17x18 mm with closing plates		
	<b>FP 1211</b> 1x12x18 mm for miniature circuit breakers (MCB)		

Circuit breaker boxes for the installation of DIN rail equipment in accordance with DIN 43 880 from 9 up to 54 modules.

	<b>FP 1106</b> 1x9x18 mm		<b>FP 1101</b> 1x12x18 mm
	<b>FP 1107</b> 1x12x18 mm with closing plates		<b>FP 1249</b> 2x12x18 mm
	<b>FP 1216</b> 2x12x18 mm		<b>FP 1349</b> 3x12x18 mm
	<b>FP 1217</b> 2x12x18 mm with closing plates		<b>FP 1439</b> 2x27x18 mm
	<b>FP 1316</b> 3x12x18 mm		<b>FP 1211</b> 1x12x18 mm for miniature circuit breakers (MCB) with PE/N terminals
	<b>FP 1317</b> 3x12x18 mm with closing plates		<b>FP 1100</b> Terminal box
	<b>FP 1406</b> 2x27x18 mm with closing plates		
	<b>FP 1417</b> 3x17x18 mm with closing plates		

Circuit breaker boxes for the installation of DIN rail equipment in accordance with DIN 43 880 from 9 up to 54 modules.

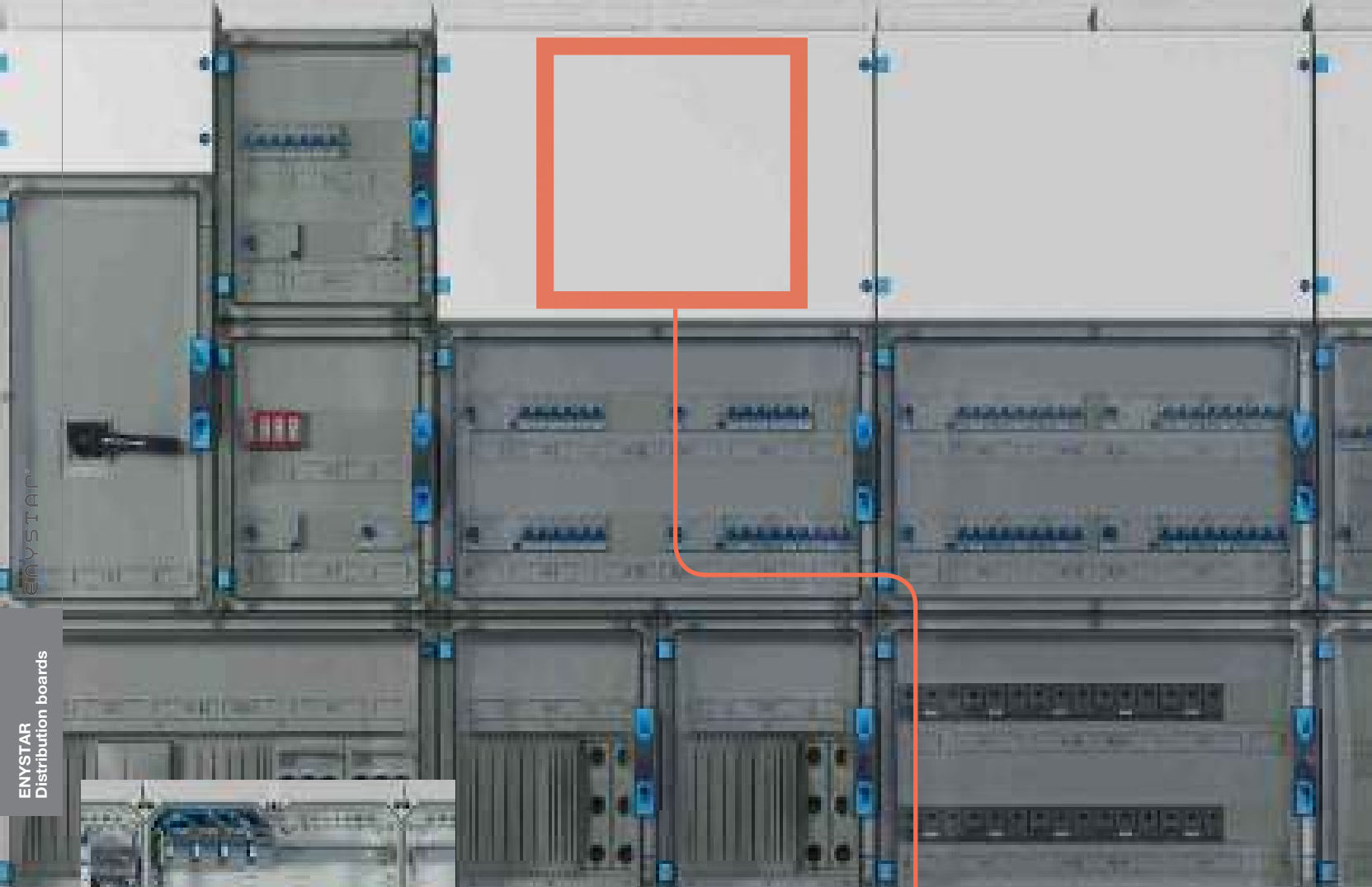

ENYSTAR  
Distribution boards



## ENYSTAR

### Empty boxes

for the assembly of distribution boards up to 250 A  
intended to be operated by ordinary persons  
in accordance with IEC 61439-3

- All enclosure sizes with door
- Transparent or opaque doors
- Device installation either on mounting plates or DIN rails
- Installation depths extendable by using extension frames
- Enclosures can also be used as single boxes when enclosure walls are covered with closing plates
- Door lockings with hand or tool operation
- Protection class II, 
- Degree of protection: IP 66
- Material: PC (polycarbonate)
- Colour: grey, RAL 7035



**FP 0140**

**Built-in dimensions W 216 x H 126 x D 140 mm  
door locking with hand operation**

- max. installation depth with built-in mounting plate 136 mm, with built-in DIN rail 125 mm
- box size 1
- with transparent door
- door locking sealable
- please order DIN rails, mounting plates or covers additionally
- connector: 4 items
- in order to achieve protection class II and degree of protection IP 66, please order closing plate sets, single closing plates and flanges separately

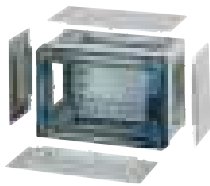
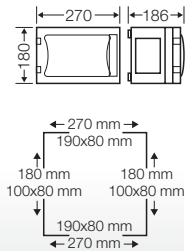

**FP 0141**

**Built-in dimensions W 216 x H 126 x D 140 mm  
door locking with hand operation  
with closing plates for box walls**

- max. installation depth with built-in mounting plate 136 mm, with built-in DIN rail 125 mm
- box size 1
- with transparent door
- door locking sealable
- please order DIN rails, mounting plates or covers additionally
- connector: 4 items
- order flanges separately

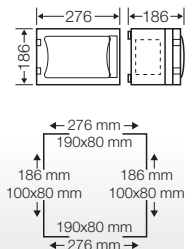

**FP 0240**

**Built-in dimensions W 216 x H 306 x D 140 mm  
door locking with hand operation**

- max. installation depth with built-in mounting plate 136 mm, with built-in DIN rail 125 mm
- box size 2
- with transparent door
- door locking sealable
- please order DIN rails, mounting plates or covers additionally
- connector: 4 items
- in order to achieve protection class II and degree of protection IP 66, please order closing plate sets, single closing plates and flanges separately

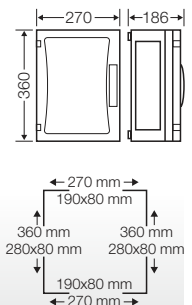

Please note:



Terminals for incoming/  
outgoing cables under  
accessories

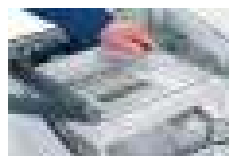

Covers for protection of  
installation device, see  
accessories



Empty enclosures with  
hinged lids



**FP 0241**

**Built-in dimensions W 216 x H 306 x D 140 mm**  
**door locking with hand operation**  
**with closing plates for box walls**

- max. installation depth with built-in mounting plate 136 mm, with built-in DIN rail 125 mm
- box size 2
- with transparent door
- door locking sealable
- please order DIN rails, mounting plates or covers additionally
- connector: 4 items
- order flanges separately

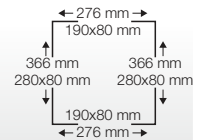
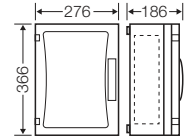

ENYSTAR®

ENYSTAR Distribution boards



**FP 0340**

**Built-in dimensions W 216 x H 486 x D 140 mm**  
**door locking with hand operation**

- max. installation depth with built-in mounting plate 136 mm, with built-in DIN rail 125 mm
- box size 3
- with transparent door
- door locking sealable
- please order DIN rails, mounting plates or covers additionally
- connector: 6 items
- in order to achieve protection class II and degree of protection IP 66, please order closing plate sets, single closing plates and flanges separately

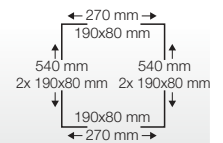
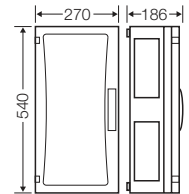

**FP 0341**

**Built-in dimensions W 216 x H 486 x D 140 mm**  
**door locking with hand operation**  
**with closing plates for box walls**

- max. installation depth with built-in mounting plate 136 mm, with built-in DIN rail 125 mm
- box size 3
- with transparent door
- door locking sealable
- please order DIN rails, mounting plates or covers additionally
- connector: 6 items
- order flanges separately

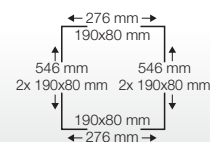
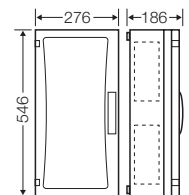

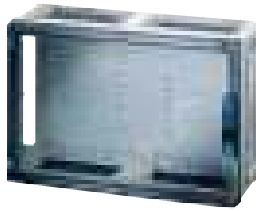

**FP 0440**

**Built-in dimensions W 486 x H 306 x D 140 mm  
door locking with hand operation**

- max. installation depth with built-in mounting plate 136 mm, with built-in DIN rail 125 mm
- box size 4
- with transparent door
- door locking sealable
- please order DIN rails, mounting plates or covers additionally
- connector: 6 items
- in order to achieve protection class II and degree of protection IP 66, please order closing plate sets, single closing plates and flanges separately

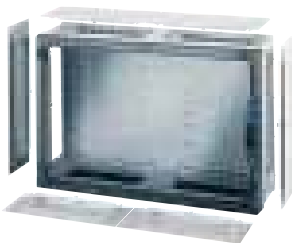
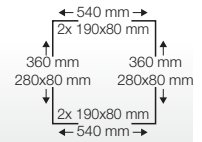
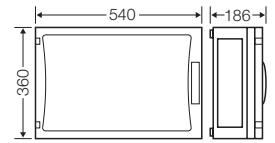

**FP 0441**

**Built-in dimensions W 486 x H 306 x D 140 mm  
door locking with hand operation  
with closing plates for box walls**

- max. installation depth with built-in mounting plate 136 mm, with built-in DIN rail 125 mm
- box size 4
- with transparent door
- door locking sealable
- please order DIN rails, mounting plates or covers additionally
- connector: 6 items
- order flanges separately

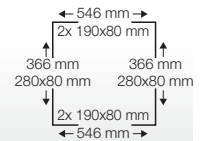
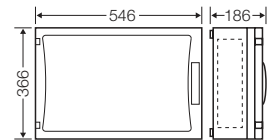

**FP 0461**

**Built-in dimensions W 306 x H 486 x D 140 mm  
door locking with hand operation  
with closing plates for box walls**

- max. installation depth with built-in mounting plate 136 mm, with built-in DIN rail 125 mm
- box size 4
- with transparent door
- door locking sealable
- please order DIN rails, mounting plates or covers additionally
- connector: 6 items
- order flanges separately

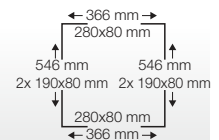
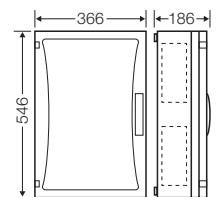

Please note:



Terminals for incoming/  
outgoing cables under  
accessories

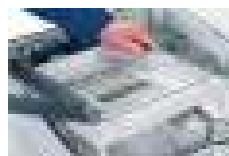

Covers for protection of  
installation device, see  
accessories



Empty enclosures with  
hinged lids



**FP 0150**

**Built-in dimensions W 216 x H 126 x D 140 mm  
door locking with hand operation**

- max. installation depth with built-in mounting plate 136 mm, with built-in DIN rail 125 mm
- with opaque door
- box size 1
- door locking sealable
- please order DIN rails, mounting plates or covers additionally
- connector: 4 items
- in order to achieve protection class II and degree of protection IP 66, please order closing plate sets, single closing plates and flanges separately

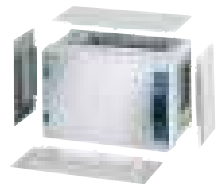
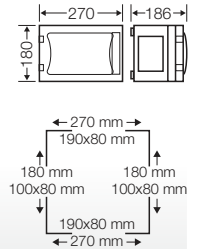

**FP 0151**

**Built-in dimensions W 216 x H 126 x D 140 mm  
door locking with hand operation  
with closing plates for box walls**

- max. installation depth with built-in mounting plate 136 mm, with built-in DIN rail 125 mm
- with opaque door
- box size 1
- door locking sealable
- please order DIN rails, mounting plates or covers additionally
- connector: 4 items
- order flanges separately

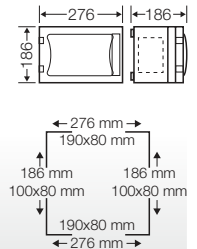

**FP 0250**

**Built-in dimensions W 216 x H 306 x D 140 mm  
door locking with hand operation**

- max. installation depth with built-in mounting plate 136 mm, with built-in DIN rail 125 mm
- with opaque door
- box size 2
- door locking sealable
- please order DIN rails, mounting plates or covers additionally
- connector: 4 items
- in order to achieve protection class II and degree of protection IP 66, please order closing plate sets, single closing plates and flanges separately

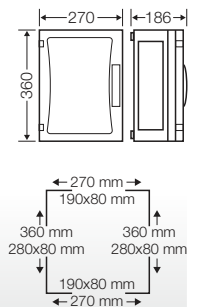



**FP 0251**

**Built-in dimensions W 216 x H 306 x D 140 mm**  
**door locking with hand operation**  
**with closing plates for box walls**

- max. installation depth with built-in mounting plate 136 mm, with built-in DIN rail 125 mm
- with opaque door
- box size 2
- door locking sealable
- please order DIN rails, mounting plates or covers additionally
- connector: 4 items
- order flanges separately

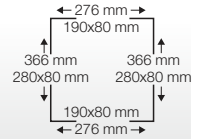
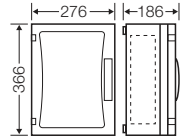

**FP 0350**

**Built-in dimensions W 216 x H 486 x D 140 mm**  
**door locking with hand operation**

- max. installation depth with built-in mounting plate 136 mm, with built-in DIN rail 125 mm
- with opaque door
- box size 3
- door locking sealable
- please order DIN rails, mounting plates or covers additionally
- connector: 6 items
- in order to achieve protection class II and degree of protection IP 66, please order closing plate sets, single closing plates and flanges separately

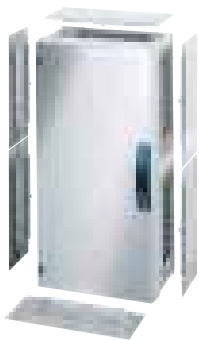
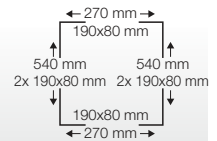
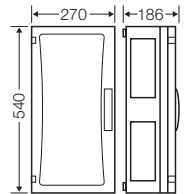

**FP 0351**

**Built-in dimensions W 216 x H 486 x D 140 mm**  
**door locking with hand operation**  
**with closing plates for box walls**

- max. installation depth with built-in mounting plate 136 mm, with built-in DIN rail 125 mm
- with opaque door
- box size 3
- door locking sealable
- please order DIN rails, mounting plates or covers additionally
- connector: 6 items
- order flanges separately

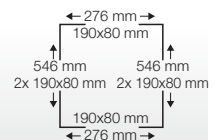
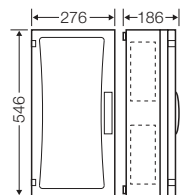

Please note:



Terminals for incoming/outgoing cables under accessories

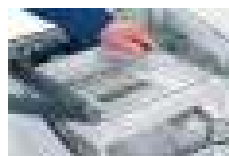

Covers for protection of installation device, see accessories



Empty enclosures with hinged lids



**FP 0450**

**Built-in dimensions W 486 x H 306 x D 140 mm  
door locking with hand operation**

- max. installation depth with built-in mounting plate 136 mm, with built-in DIN rail 125 mm
- with opaque door
- box size 4
- door locking sealable
- please order DIN rails, mounting plates or covers additionally
- connector: 6 items
- in order to achieve protection class II and degree of protection IP 66, please order closing plate sets, single closing plates and flanges separately

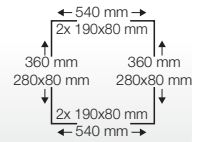
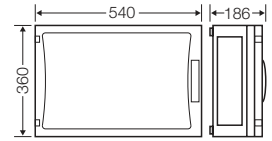

ENYSTAR® Distribution boards



**FP 0451**

**Built-in dimensions W 486 x H 306 x D 140 mm  
door locking with hand operation  
with closing plates for box walls**

- max. installation depth with built-in mounting plate 136 mm, with built-in DIN rail 125 mm
- with opaque door
- box size 4
- door locking sealable
- please order DIN rails, mounting plates or covers additionally
- connector: 6 items
- order flanges separately

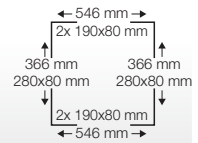
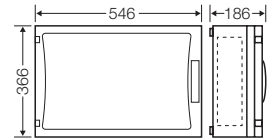

**FP 0471**

**Built-in dimensions W 306 x H 486 x D 140 mm  
door locking with hand operation  
with closing plates for box walls**

- max. installation depth with built-in mounting plate 136 mm, with built-in DIN rail 125 mm
- with opaque door
- box size 4
- door locking sealable
- please order DIN rails, mounting plates or covers additionally
- connector: 6 items
- order flanges separately

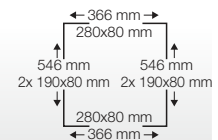
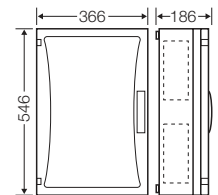



**FP 0100**

**Built-in dimensions W 216 x H 126 x D 140 mm  
door fastener with tool operation**

- max. installation depth with built-in mounting plate 136 mm, with built-in DIN rail 125 mm
- box size 1
- with transparent door
- sealing device for door sealing order separately
- please order DIN rails, mounting plates or covers additionally
- connector: 4 items
- in order to achieve protection class II and degree of protection IP 66, please order closing plate sets, single closing plates and flanges separately

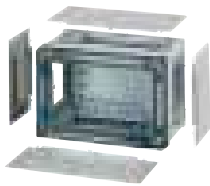
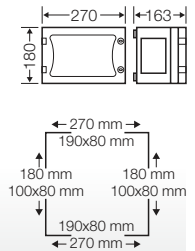

**FP 0101**

**Built-in dimensions W 216 x H 126 x D 140 mm  
door fastener with tool operation  
with closing plates for box walls**

- max. installation depth with built-in mounting plate 136 mm, with built-in DIN rail 125 mm
- box size 1
- with transparent door
- sealing device for door sealing order separately
- please order DIN rails, mounting plates or covers additionally
- connector: 4 items
- order flanges separately

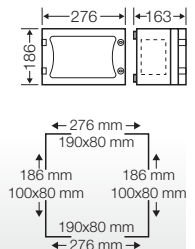

**FP 0210**

**Built-in dimensions W 216 x H 306 x D 140 mm  
door fastener with tool operation**

- max. installation depth with built-in mounting plate 136 mm, with built-in DIN rail 125 mm
- box size 2
- with transparent door
- sealing device for door sealing order separately
- please order DIN rails, mounting plates or covers additionally
- connector: 4 items
- in order to achieve protection class II and degree of protection IP 66, please order closing plate sets, single closing plates and flanges separately

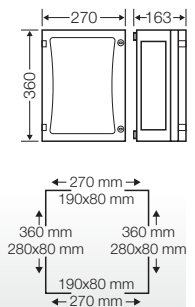

Please note:



Terminals for incoming/  
outgoing cables under  
accessories

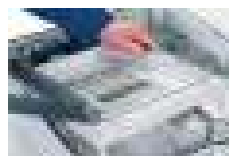

Covers for protection of  
installation device, see  
accessories



Empty enclosures with  
hinged lids



**FP 0211**

**Built-in dimensions W 216 x H 306 x D 140 mm  
door fastener with tool operation  
with closing plates for box walls**

- max. installation depth with built-in mounting plate 136 mm, with built-in DIN rail 125 mm
- box size 2
- with transparent door
- sealing device for door sealing order separately
- please order DIN rails, mounting plates or covers additionally
- connector: 4 items
- order flanges separately

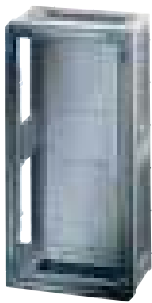
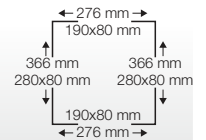
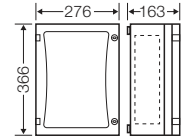

**FP 0310**

**Built-in dimensions W 216 x H 486 x D 140 mm  
door fastener with tool operation**

- max. installation depth with built-in mounting plate 136 mm, with built-in DIN rail 125 mm
- box size 3
- with transparent door
- sealing device for door sealing order separately
- please order DIN rails, mounting plates or covers additionally
- connector: 6 items
- in order to achieve protection class II and degree of protection IP 66, please order closing plate sets, single closing plates and flanges separately

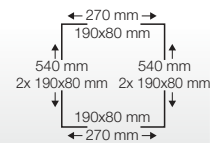
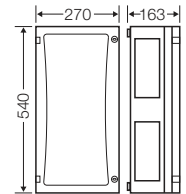

**FP 0311**

**Built-in dimensions W 216 x H 486 x D 140 mm  
door fastener with tool operation  
with closing plates for box walls**

- max. installation depth with built-in mounting plate 136 mm, with built-in DIN rail 125 mm
- box size 3
- with transparent door
- sealing device for door sealing order separately
- please order DIN rails, mounting plates or covers additionally
- connector: 6 items
- order flanges separately

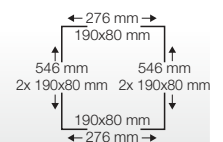
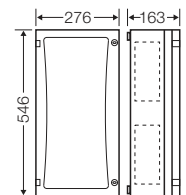

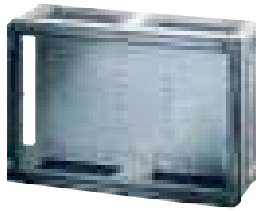

**FP 0400**

**Built-in dimensions W 486 x H 306 x D 140 mm  
door fastener with tool operation**

- max. installation depth with built-in mounting plate 136 mm, with built-in DIN rail 125 mm
- box size 4
- with transparent door
- sealing device for door sealing order separately
- please order DIN rails, mounting plates or covers additionally
- connector: 6 items
- in order to achieve protection class II and degree of protection IP 66, please order closing plate sets, single closing plates and flanges separately

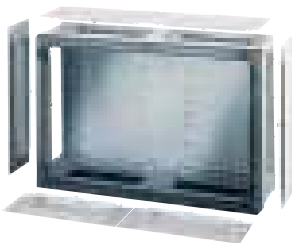
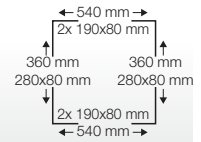
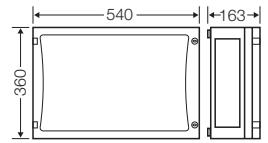

**FP 0401**

**Built-in dimensions W 486 x H 306 x D 140 mm  
door fastener with tool operation  
with closing plates for box walls**

- max. installation depth with built-in mounting plate 136 mm, with built-in DIN rail 125 mm
- box size 4
- with transparent door
- sealing device for door sealing order separately
- please order DIN rails, mounting plates or covers additionally
- connector: 6 items
- order flanges separately

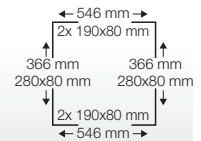
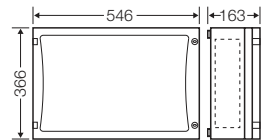

**FP 0411**

**Built-in dimensions W 306 x H 486 x D 140 mm  
door fastener with tool operation  
with closing plates for box walls**

- max. installation depth with built-in mounting plate 136 mm, with built-in DIN rail 125 mm
- box size 4
- with transparent door
- sealing device for door sealing order separately
- please order DIN rails, mounting plates or covers additionally
- connector: 6 items
- order flanges separately

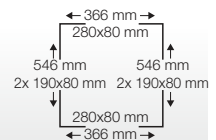
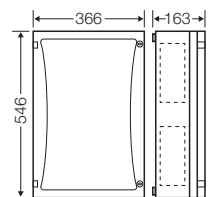

Please note:



Terminals for incoming/  
outgoing cables under  
accessories

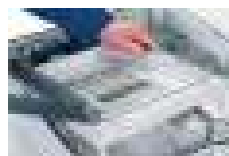

Covers for protection of  
installation device, see  
accessories



Empty enclosures with  
hinged lids



**FP 0120**

**Built-in dimensions W 216 x H 126 x D 140 mm**  
**door fastener with tool operation**

- max. installation depth with built-in mounting plate 136 mm, with built-in DIN rail 125 mm
- with opaque door
- box size 1
- sealing device for door sealing order separately
- please order DIN rails, mounting plates or covers additionally
- connector: 4 items
- in order to achieve protection class II and degree of protection IP 66, please order closing plate sets, single closing plates and flanges separately

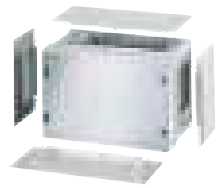
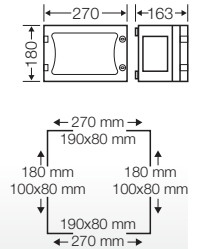

**FP 0121**

**Built-in dimensions W 216 x H 126 x D 140 mm**  
**door fastener with tool operation**  
**with closing plates for box walls**

- max. installation depth with built-in mounting plate 136 mm, with built-in DIN rail 125 mm
- with opaque door
- box size 1
- sealing device for door sealing order separately
- please order DIN rails, mounting plates or covers additionally
- connector: 4 items
- order flanges separately

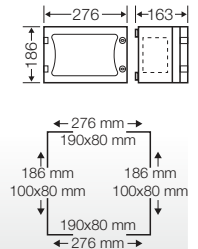

**FP 0230**

**Built-in dimensions W 216 x H 306 x D 140 mm**  
**door fastener with tool operation**

- max. installation depth with built-in mounting plate 136 mm, with built-in DIN rail 125 mm
- with opaque door
- box size 2
- sealing device for door sealing order separately
- please order DIN rails, mounting plates or covers additionally
- connector: 4 items
- in order to achieve protection class II and degree of protection IP 66, please order closing plate sets, single closing plates and flanges separately

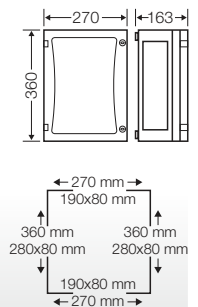



**FP 0231**

**Built-in dimensions W 216 x H 306 x D 140 mm**  
**door fastener with tool operation**  
**with closing plates for box walls**

- max. installation depth with built-in mounting plate 136 mm, with built-in DIN rail 125 mm
- with opaque door
- box size 2
- sealing device for door sealing order separately
- please order DIN rails, mounting plates or covers additionally
- connector: 4 items
- order flanges separately

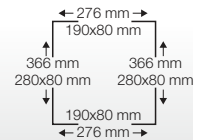
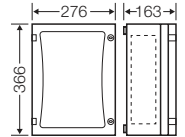

**FP 0330**

**Built-in dimensions W 216 x H 486 x D 140 mm**  
**door fastener with tool operation**

- max. installation depth with built-in mounting plate 136 mm, with built-in DIN rail 125 mm
- with opaque door
- box size 3
- sealing device for door sealing order separately
- please order DIN rails, mounting plates or covers additionally
- connector: 6 items
- in order to achieve protection class II and degree of protection IP 66, please order closing plate sets, single closing plates and flanges separately

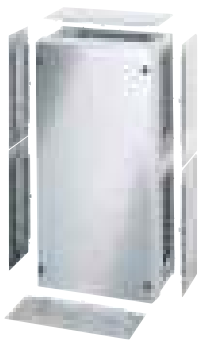
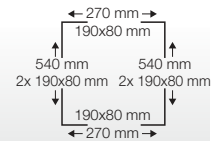
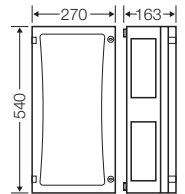

**FP 0331**

**Built-in dimensions W 216 x H 486 x D 140 mm**  
**door fastener with tool operation**  
**with closing plates for box walls**

- max. installation depth with built-in mounting plate 136 mm, with built-in DIN rail 125 mm
- with opaque door
- box size 3
- sealing device for door sealing order separately
- please order DIN rails, mounting plates or covers additionally
- connector: 6 items
- order flanges separately

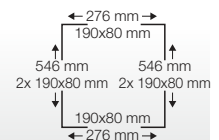
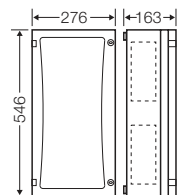

Please note:



Terminals for incoming/  
 outgoing cables under  
 accessories

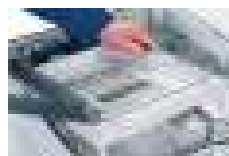

Covers for protection of  
 installation device, see  
 accessories



Empty enclosures with  
 hinged lids



**FP 0420**

**Built-in dimensions W 486 x H 306 x D 140 mm**  
**door fastener with tool operation**

- max. installation depth with built-in mounting plate 136 mm, with built-in DIN rail 125 mm
- with opaque door
- box size 4
- sealing device for door sealing order separately
- please order DIN rails, mounting plates or covers additionally
- connector: 6 items
- in order to achieve protection class II and degree of protection IP 66, please order closing plate sets, single closing plates and flanges separately

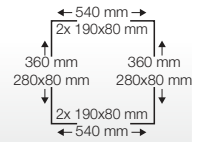
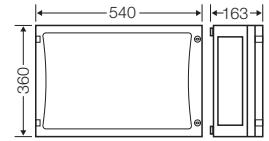

**FP 0421**

**Built-in dimensions W 486 x H 306 x D 140 mm**  
**door fastener with tool operation**  
**with closing plates for box walls**

- max. installation depth with built-in mounting plate 136 mm, with built-in DIN rail 125 mm
- with opaque door
- box size 4
- sealing device for door sealing order separately
- please order DIN rails, mounting plates or covers additionally
- connector: 6 items
- order flanges separately

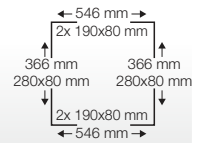
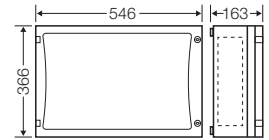

**FP 0431**

**Built-in dimensions W 306 x H 486 x D 140 mm**  
**door fastener with tool operation**  
**with closing plates for box walls**

- max. installation depth with built-in mounting plate 136 mm, with built-in DIN rail 125 mm
- with opaque door
- box size 4
- sealing device for door sealing order separately
- please order DIN rails, mounting plates or covers additionally
- connector: 6 items
- order flanges separately

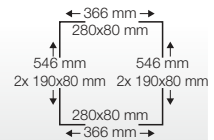
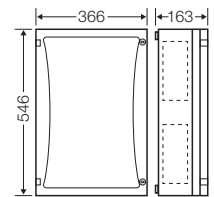



## ENYSTAR

### Circuit breaker box

for the assembly of distribution boards up to 250 A  
intended to be operated by ordinary persons  
in accordance with IEC 61439-3

- Transparent doors
- door locking with hand operation, lockable with tool or key
- Circuit breaker boxes with or without PE and N terminals
- Protection against direct contact with hazardous live parts for operable installation devices
- Blanking strips for unused DIN rail openings
- Attached labelling strips for circuit identification
- Enclosures can also be used as single boxes when enclosure walls are covered with closing plates
- Protection class II, 
- Degree of protection: IP 66
- Material: PC (polycarbonate)
- Colour: grey, RAL 7035



**FP 1109**

**9 modules: 1 x 9 x 18 mm**

- 1-row
- box size 1
- FIXCONNECT® plug-in terminal technology for PE and N
- PE/N 2 x 25 mm<sup>2</sup>, 8 x 4 mm<sup>2</sup>, Cu each
- N separable for various potentials
- for installation of DIN rail equipment up to 63 A in accordance with DIN 43880
- with transparent door
- door locking with hand operation
- door locking sealable
- with blanking strips for unused DIN rail openings
- with labelling strips
- connector: 4 items
- in order to achieve protection class II and degree of protection IP 66, please order closing plate sets, single closing plates and flanges separately

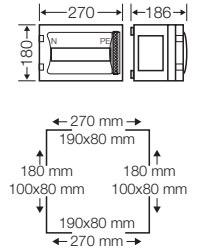

ENYSTAR® Distribution boards

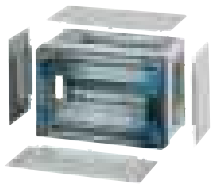

**FP 1108**

**9 modules: 1 x 9 x 18 mm**  
**with closing plates for box walls**

- 1-row
- box size 1
- FIXCONNECT® plug-in terminal technology for PE and N
- PE/N 2 x 25 mm<sup>2</sup>, 8 x 4 mm<sup>2</sup>, Cu each
- N separable for various potentials
- for installation of DIN rail equipment up to 63 A in accordance with DIN 43880
- with transparent door
- door locking with hand operation
- door locking sealable
- with blanking strips for unused DIN rail openings
- with labelling strips
- connector: 4 items
- order flanges separately

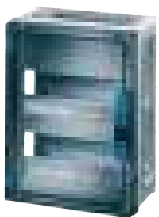
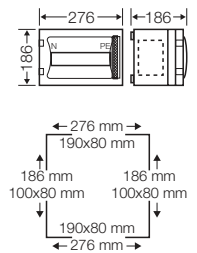

**FP 1219**

**24 modules: 2 x 12 x 18 mm**

- 2-row
- box size 2
- FIXCONNECT® plug-in terminal technology for PE and N
- per PE/N 3 x 25 mm<sup>2</sup>, 12 x 4 mm<sup>2</sup>, Cu
- N separable for various potentials
- for installation of DIN rail equipment up to 63 A in accordance with DIN 43880
- with transparent door
- door locking sealable
- door locking with hand operation
- with blanking strips for unused DIN rail openings
- with labelling strips
- connector: 4 items
- in order to achieve protection class II and degree of protection IP 66, please order closing plate sets, single closing plates and flanges separately

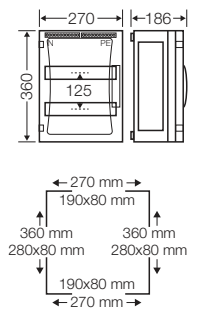



**FP 1218**

**24 modules: 2 x 12 x 18 mm**  
**with closing plates for box walls**

- 2-row
- box size 2
- FIXCONNECT® plug-in terminal technology for PE and N
- per PE/N 3 x 25 mm<sup>2</sup>, 12 x 4 mm<sup>2</sup>, Cu
- N separable for various potentials
- for installation of DIN rail equipment up to 63 A in accordance with DIN 43880
- with transparent door
- door locking with hand operation
- door locking sealable
- with blanking strips for unused DIN rail openings
- with labelling strips
- connector: 4 items
- order flanges separately

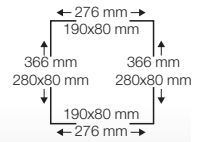
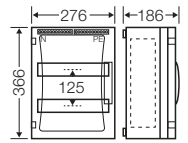

**FP 1319**

**36 modules: 3 x 12 x 18 mm**

- 3-row
- box size 3
- FIXCONNECT® plug-in terminal technology for PE and N
- per PE/N 6 x 25 mm<sup>2</sup>, 24 x 4 mm<sup>2</sup>, Cu
- N separable for various potentials
- for installation of DIN rail equipment up to 63 A in accordance with DIN 43880
- with transparent door
- door locking with hand operation
- door locking sealable
- with blanking strips for unused DIN rail openings
- with labelling strips
- connector: 6 items
- in order to achieve protection class II and degree of protection IP 66, please order closing plate sets, single closing plates and flanges separately

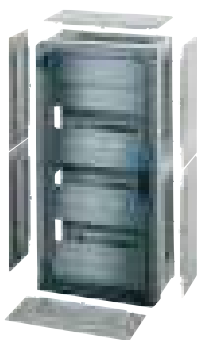
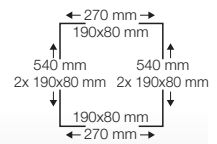
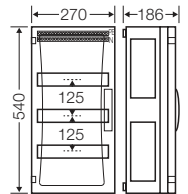

**FP 1318**

**36 modules: 3 x 12 x 18 mm**  
**with closing plates for box walls**

- 3-row
- box size 3
- FIXCONNECT® plug-in terminal technology for PE and N
- per PE/N 6 x 25 mm<sup>2</sup>, 24 x 4 mm<sup>2</sup>, Cu
- N separable for various potentials
- for installation of DIN rail equipment up to 63 A in accordance with DIN 43880
- with transparent door
- door locking with hand operation
- door locking sealable
- with blanking strips for unused DIN rail openings
- with labelling strips
- connector: 6 items
- order flanges separately

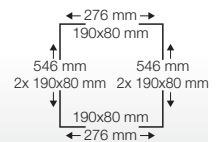
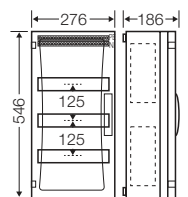

Please note:



Connection box for plug devices, push buttons or switches under accessories



Cover cutouts against direct contact with hazardous live parts



Editable labelling strips

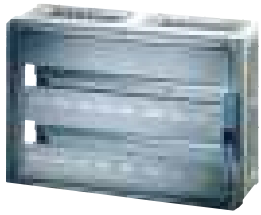

**FP 1409**

**54 modules: 2 x 27 x 18 mm**

- 2-row
- box size 4
- FIXCONNECT® plug-in terminal technology for PE and N
- per PE/N 6 x 25 mm<sup>2</sup>, 24 x 4 mm<sup>2</sup>, Cu
- N separable for various potentials
- for installation of DIN rail equipment up to 63 A in accordance with DIN 43880
- with transparent door
- door locking with hand operation
- door locking sealable
- with blanking strips for unused DIN rail openings
- with labelling strips
- connector: 6 items
- in order to achieve protection class II and degree of protection IP 66, please order closing plate sets, single closing plates and flanges separately

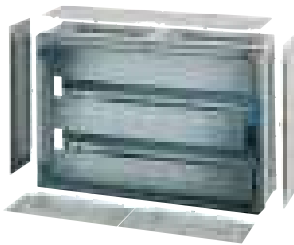
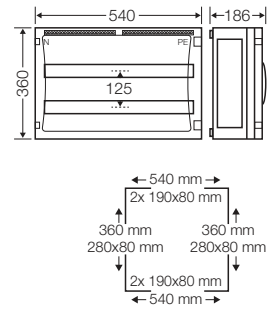

**FP 1408**

**54 modules: 2 x 27 x 18 mm**  
**with closing plates for box walls**

- 2-row
- box size 4
- FIXCONNECT® plug-in terminal technology for PE and N
- per PE/N 6 x 25 mm<sup>2</sup>, 24 x 4 mm<sup>2</sup>, Cu
- N separable for various potentials
- for installation of DIN rail equipment up to 63 A in accordance with DIN 43880
- with transparent door
- door locking with hand operation
- door locking sealable
- with blanking strips for unused DIN rail openings
- with labelling strips
- connector: 6 items
- order flanges separately

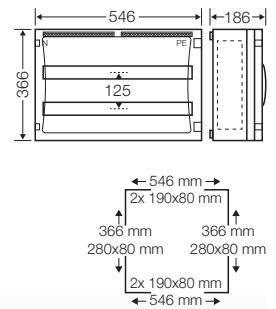

**FP 1418**

**51 modules: 3 x 17 x 18 mm**  
**with closing plates for box walls**

- 3-row
- box size 4
- FIXCONNECT® plug-in terminal technology for PE and N
- per PE/N 8 x 25 mm<sup>2</sup>, 32 x 4 mm<sup>2</sup>, Cu
- N separable for various potentials
- for installation of DIN rail equipment up to 63 A in accordance with DIN 43880
- with transparent door
- door locking with hand operation
- door locking sealable
- with blanking strips for unused DIN rail openings
- with labelling strips
- connector: 6 items
- order flanges separately

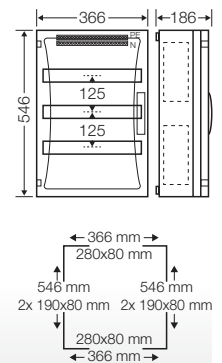



**FP 1211**

**12 modules: 1 x 12 x 18 mm**  
**for miniature circuit breakers (MCB)**

- 1-row
- box size 2
- with 1 DIN rail 216 mm wide (for installation depth of 72 mm)
- for installation of DIN rail equipment up to 100 A in accordance with DIN 43 880
- per PE/N 2 x 25 mm<sup>2</sup>, 4 x 16 mm<sup>2</sup>, Cu
- cover can be sealed
- with lockable blanking strips
- connector: 4 items
- in order to achieve protection class II and degree of protection IP 66, please order closing plate sets, single closing plates and flanges separately

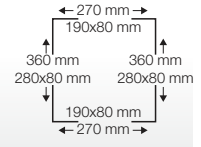
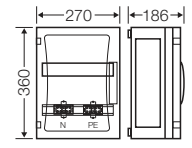

Please note:



Connection box for plug devices, push buttons or switches under accessories



Cover cutouts against direct contact with hazardous live parts

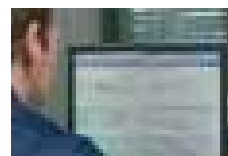

Editable labelling strips

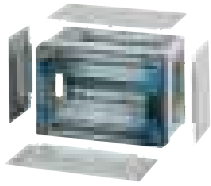

**FP 1105**

**12 modules: 1 x 12 x 18 mm**  
**without PE and N terminal**  
**with closing plates for box walls**

- 1-row
- box size 1
- for installation of DIN rail equipment up to 63 A in accordance with DIN 43880
- order PE/N terminals separately
- with transparent door
- door locking with hand operation
- door locking sealable
- with blanking strips for unused DIN rail openings
- with labelling strips
- connector: 4 items
- walls closed with closing plates, closing plate set included
- order flanges separately

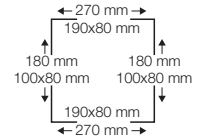
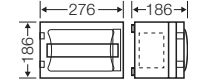

**FP 1215**

**24 modules: 2 x 12 x 18 mm**  
**without PE and N terminal**  
**with closing plates for box walls**

- 2-row
- box size 2
- order PE/N terminals separately
- for installation of DIN rail equipment up to 63 A in accordance with DIN 43880
- with transparent door
- door locking with hand operation
- door locking sealable
- with blanking strips for unused DIN rail openings
- with labelling strips
- connector: 4 items
- walls closed with closing plates, closing plate set included
- order flanges separately

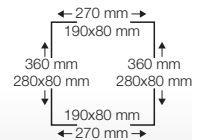
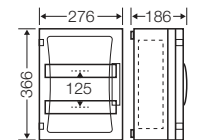

**FP 1315**

**36 modules: 3 x 12 x 18 mm**  
**without PE and N terminal**  
**with closing plates for box walls**

- 3-row
- box size 3
- order PE/N terminals separately
- for installation of DIN rail equipment up to 63 A in accordance with DIN 43880
- with transparent door
- door locking with hand operation
- door locking sealable
- with blanking strips for unused DIN rail openings
- with labelling strips
- connector: 6 items
- walls closed with closing plates, closing plate set included
- order flanges separately

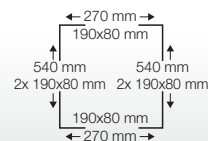
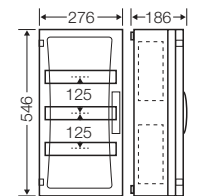



**FP 1415**

**51 modules: 3 x 17 x 18 mm**  
**without PE and N terminal**  
**with closing plates for box walls**

- 3-row
- box size 4
- order PE/N terminals separately
- for installation of DIN rail equipment up to 63 A in accordance with DIN 43880
- with transparent door
- door locking with hand operation
- door locking sealable
- with blanking strips for unused DIN rail openings
- with labelling strips
- connector: 6 items
- walls closed with closing plates, closing plate set included
- order flanges separately

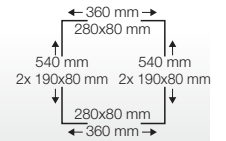
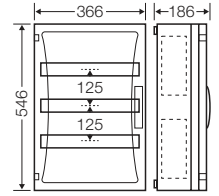

Please note:



Connection box for plug devices, push buttons or switches under accessories



Cover cutouts against direct contact with hazardous live parts



Editable labelling strips

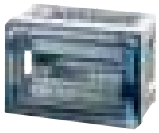

**FP 1106**

**12 modules: 1 x 12 x 18 mm**  
**without PE and N terminal**  
**with removable DIN rail rack and earth connection**

- 1-row
- box size 1
- order PE/N terminals separately
- with installation of a PE/N terminal the number of modules is reduced to 1 x 9 x 18 mm
- for installation of DIN rail equipment up to 63 A in accordance with DIN 43880
- with transparent door
- door locking with hand operation
- door locking sealable
- with blanking strips for unused DIN rail openings
- with labelling strips
- connector: 4 items
- in order to achieve protection class II and degree of protection IP 66, please order closing plate sets, single closing plates and flanges separately

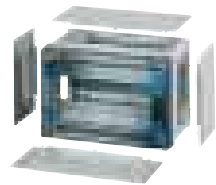
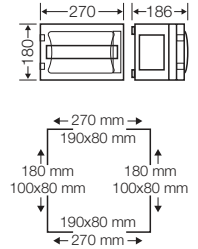

**FP 1107**

**12 modules: 1 x 12 x 18 mm**  
**without PE and N terminal**  
**with closing plates for box walls**  
**with removable DIN rail rack and earth connection**

- 1-row
- box size 1
- order PE/N terminals separately
- with installation of a PE/N terminal the number of modules is reduced to 1 x 9 x 18 mm
- for installation of DIN rail equipment up to 63 A in accordance with DIN 43880
- with transparent door
- door locking with hand operation
- door locking sealable
- with blanking strips for unused DIN rail openings
- with labelling strips
- connector: 4 items
- walls closed with closing plates, closing plate set included
- order flanges separately

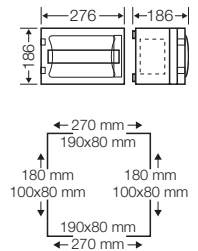

Removable DIN rail rack for  
 e.g. earth connection (British standard)





**FP 1216**

**24 modules: 2 x 12 x 18 mm**  
**without PE and N terminal**  
**with removable DIN rail rack and earth connection**

- 2-row
- box size 2
- order PE/N terminals separately
- for installation of DIN rail equipment up to 63 A in accordance with DIN 43880
- with transparent door
- door locking with hand operation
- door locking sealable
- with blanking strips for unused DIN rail openings
- with labelling strips
- connector: 4 items
- in order to achieve protection class II and degree of protection IP 66, please order closing plate sets, single closing plates and flanges separately

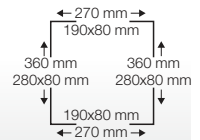
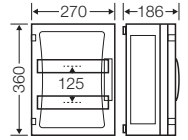

**FP 1217**

**24 modules: 2 x 12 x 18 mm**  
**without PE and N terminal**  
**with closing plates for box walls**  
**with removable DIN rail rack and earth connection**

- 2-row
- box size 2
- order PE/N terminals separately
- for installation of DIN rail equipment up to 63 A in accordance with DIN 43880
- with transparent door
- door locking with hand operation
- door locking sealable
- with blanking strips for unused DIN rail openings
- with labelling strips
- connector: 4 items
- walls closed with closing plates, closing plate set included
- order flanges separately

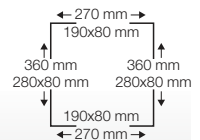
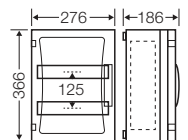

Please note:



Connection box for plug devices, push buttons or switches under accessories



Cover cutouts against direct contact with hazardous live parts



Editable labelling strips



**FP 1316**

**36 modules: 3 x 12 x 18 mm**  
**without PE and N terminal**  
**with removable DIN rail rack and earth connection**

- 3-row
- box size 3
- order PE/N terminals separately
- for installation of DIN rail equipment up to 63 A in accordance with DIN 43880
- with transparent door
- door locking with hand operation
- door locking sealable
- with blanking strips for unused DIN rail openings
- with labelling strips
- connector: 6 items
- in order to achieve protection class II and degree of protection IP 66, please order closing plate sets, single closing plates and flanges separately

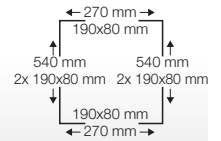
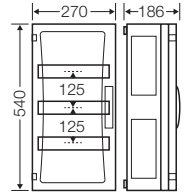

**FP 1317**

**36 modules: 3 x 12 x 18 mm**  
**without PE and N terminal**  
**with closing plates for box walls**  
**with removable DIN rail rack and earth connection**

- 3-row
- box size 3
- order PE/N terminals separately
- for installation of DIN rail equipment up to 63 A in accordance with DIN 43880
- with transparent door
- door locking with hand operation
- door locking sealable
- with blanking strips for unused DIN rail openings
- with labelling strips
- connector: 6 items
- walls closed with closing plates, closing plate set included
- order flanges separately

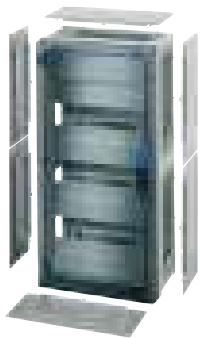
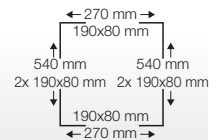
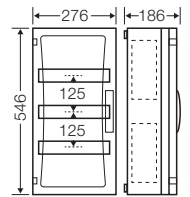

Removable DIN rail rack for  
 e.g. earth connection (British standard)



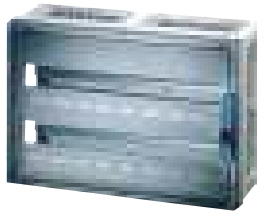

**FP 1406**

**54 modules: 2 x 27 x 18 mm**  
**without PE and N terminal**  
**with removable DIN rail rack and earth connection**

- 2-row
- box size 4
- order PE/N terminals separately
- for installation of DIN rail equipment up to 63 A in accordance with DIN 43880
- with transparent door
- door locking with hand operation
- door locking sealable
- with blanking strips for unused DIN rail openings
- with labelling strips
- connector: 6 items
- in order to achieve protection class II and degree of protection IP 66, please order closing plate sets, single closing plates and flanges separately

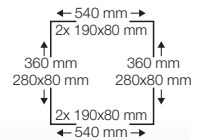
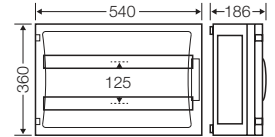

**FP 1417**

**51 modules: 3 x 17 x 18 mm**  
**without PE and N terminal**  
**with closing plates for box walls**  
**with removable DIN rail rack and earth connection**

- 3-row
- box size 4
- order PE/N terminals separately
- for installation of DIN rail equipment up to 63 A in accordance with DIN 43880
- with transparent door
- door locking with hand operation
- door locking sealable
- with blanking strips for unused DIN rail openings
- with labelling strips
- connector: 6 items
- walls closed with closing plates, closing plate set included
- order flanges separately

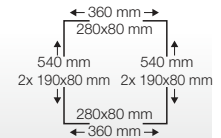
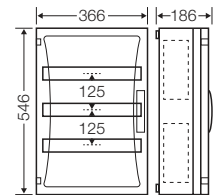

Please note:



Connection box for plug devices, push buttons or switches under accessories



Cover cutouts against direct contact with hazardous live parts



Editable labelling strips



**FP 1101**

**12 modules: 1 x 12 x 18 mm**  
**without PE and N terminal**

- 1-row
- box size 1
- for installation of DIN rail equipment up to 100 A in accordance with DIN 43 880
- use enclosure FP 1100 for N/PE terminals
- with transparent door
- door locking with hand operation
- door locking sealable
- with blanking strips for unused DIN rail openings
- with labelling strips
- connector: 4 items
- in order to achieve protection class II and degree of protection IP 66, please order closing plate sets, single closing plates and flanges separately

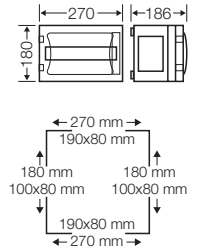

**FP 1249**

**24 modules: 2 x 12 x 18 mm**  
**without PE and N terminal**

- 2-row
- box size 2
- for installation of DIN rail equipment up to 100 A in accordance with DIN 43 880
- use enclosure FP 1100 for N/PE terminals
- with transparent door
- door locking with hand operation
- door locking sealable
- with blanking strips for unused DIN rail openings
- with labelling strips
- connector: 4 items
- in order to achieve protection class II and degree of protection IP 66, please order closing plate sets, single closing plates and flanges separately

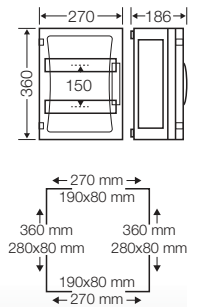

**FP 1349**

**36 modules: 3 x 12 x 18 mm**  
**without PE and N terminal**

- 3-row
- box size 3
- for installation of DIN rail equipment up to 100 A in accordance with DIN 43 880
- use enclosure FP 1100 for N/PE terminals
- with transparent door
- door locking with hand operation
- door locking sealable
- with blanking strips for unused DIN rail openings
- with labelling strips
- connector: 6 items
- in order to achieve protection class II and degree of protection IP 66, please order closing plate sets, single closing plates and flanges separately

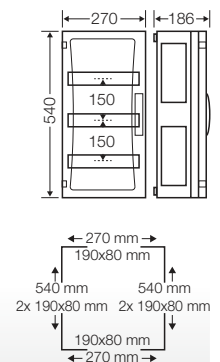

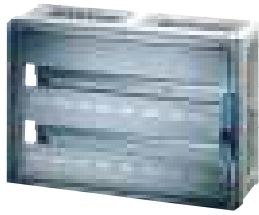

**FP 1439**

**54 modules: 2 x 27 x 18 mm**  
**without PE and N terminal**

- 2-row
- box size 4
- for installation of DIN rail equipment up to 100 A in accordance with DIN 43 880
- use enclosure FP 1100 for N/PE terminals
- with transparent door
- door locking with hand operation
- door locking sealable
- with blanking strips for unused DIN rail openings
- with labelling strips
- connector: 6 items
- in order to achieve protection class II and degree of protection IP 66, please order closing plate sets, single closing plates and flanges separately

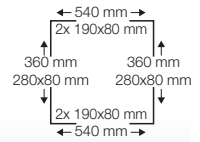
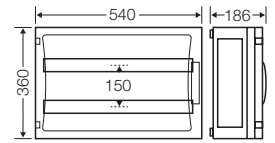

**FP 1211**

**12 modules: 1 x 12 x 18 mm**  
**for miniature circuit breakers (MCB)**

- 1-row
- box size 2
- with 1 DIN rail 216 mm wide (for installation depth of 72 mm)
- for installation of DIN rail equipment up to 100 A in accordance with DIN 43 880
- per PE/N 2 x 25 mm<sup>2</sup>, 4 x 16 mm<sup>2</sup>, Cu
- cover can be sealed
- with lockable blanking strips
- connector: 4 items
- in order to achieve protection class II and degree of protection IP 66, please order closing plate sets, single closing plates and flanges separately

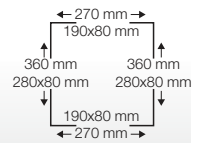
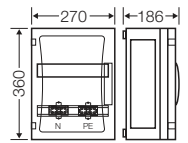

Please note:



Connection box for plug devices, push buttons or switches under accessories



Cover cutouts against direct contact with hazardous live parts



Editable labelling strips



**FP 1100**

**Terminal box**

per PE/N 10 x 1.5-10 mm<sup>2</sup> sol / f,  
 11 x 2.5-16 mm<sup>2</sup> r / f, 1 x 16 mm<sup>2</sup> sol or  
 1 x 16-35 mm<sup>2</sup> f, Cu

- rated current: 125 A
- box size 1
- with opaque door
- door fastener with tool operation
- sealing device for door sealing order separately
- in order to achieve protection class II and degree of protection IP 66, please order closing plate sets, single closing plates and flanges separately

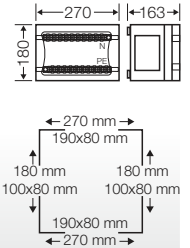

**Example: ENYSTAR distribution board**

**Incoming: 100 A**  
**36 modules: 3 x 12 x 18 mm**

**Enclosure:**

- 1 x FP 1349
- 1 x FP 1211
- 1 x FP 1100

**Accessories:**

- 2 x FP VP 18
- 4 x FP VP 27
- 2 x FP VP 36
- 1 x FP FM 263
- 1 x FP FM 225

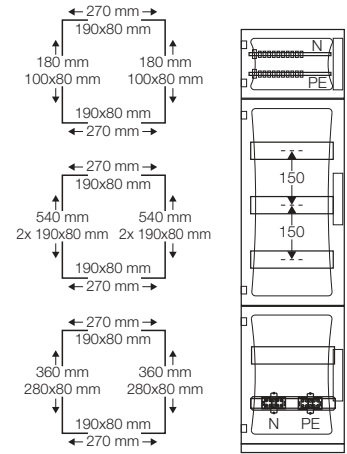



## ENYSTAR

### Accessories

Connection Box	264
Extension frames, DIN rails, spacer	265
Mounting plates for the installation of devices	266
Covers, sealing device for covers	267
Partition, blanking strips, spacer for DIN rail mounted device	268
PE / N terminals, main line branch terminals	269 - 271
Wall separators, closing plates	272 - 273
Metal inserts for closing plates	274
Flanges	275 - 276
Ventilation / pressure compensation	277 - 278
Canopy	279
Connectors, facility for sealing, conversion kit for door fastener, door lock, dust protection cover, external brackets, mounting profiles	280 - 281

**FP CB 210****Connection Box**

- for mounting on box walls (270 mm)
- hinged mounting area
- for the installation of devices that must be operated externally, such as plug devices, push buttons and switches

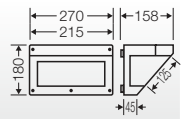

Application:

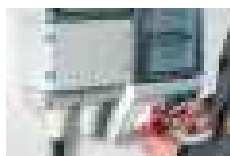

Connection box for plug devices, push buttons or switches under accessories



**FP ZR 20**  
**Extension frame**  
**for enclosure size 2**

- for extension of the installation depth by 50 mm
- inclusive fixing material
- suitable for fixing the cover FP AP 20 in different installation depths

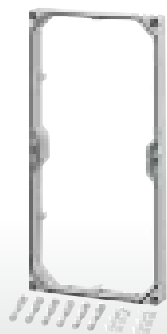
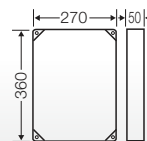

**FP ZR 30**  
**Extension frame**  
**for enclosures size 3**

- for extension of the installation depth by 50 mm
- inclusive fixing material
- suitable for the admission of cover FP AP 30 in different installation depths

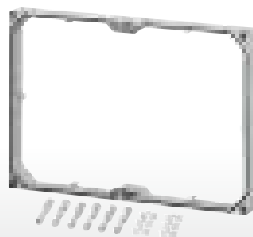
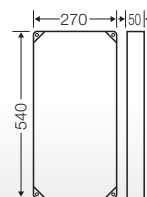

**FP ZR 40**  
**Extension frame**  
**for enclosure size 4**

- for extension of the installation depth by 50 mm
- inclusive fixing material
- suitable for the admission of cover FP AP 40 in different installation depths

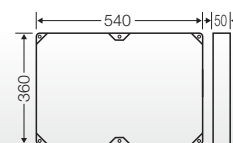

**FP TS 27**  
**DIN rail, length 216 mm**

- in accordance with DIN EN 60715
- for ENYSTAR empty boxes sizes 1, 2 and 3
- for equipment or terminals with clip-on mounting
- with fixing screws

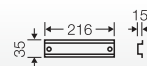

**FP TS 36**  
**DIN rail, length 306 mm**

- in accordance with DIN EN 60715
- for ENYSTAR empty boxes sizes 2 and 4
- for equipment or terminals with clip-on mounting
- with fixing screws

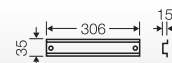

**FP TS 54**  
**DIN rail, length 486 mm**

- in accordance with DIN EN 60715
- for ENYSTAR empty boxes sizes 3 and 4
- for equipment or terminals with clip-on mounting
- with fixing screws

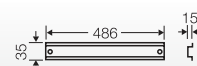

**FP DS 02**  
**Spacer**  
**height: 29.5 mm or 53.5 mm**

- for spacing DIN rails ENYSTAR
- 2 pieces
- with fixing screws for fixing on bottoms
- To change height turn spacer by 90°.

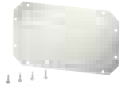

**FP MP 10**

**Mounting plate**  
**W 216 x H 126 mm**

- for ENYSTAR empty boxes sizes 1, 2 and 3
- material thickness 4 mm
- with fixing screws



**FP MP 20**

**Mounting plate**  
**W 216 x H 306 mm**

- for ENYSTAR empty boxes sizes 2, 3 and 4
- material thickness 4 mm
- with fixing screws



**FP MP 30**

**Mounting plate**  
**W 216 x H 486 mm**

- for ENYSTAR empty boxes sizes 3 and 4
- material thickness 4 mm
- with fixing screws

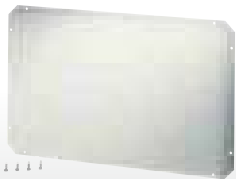
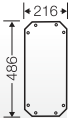

**FP MP 40**

**Mounting plate**  
**W 486 x H 306 mm**

- for ENYSTAR empty boxes size 4
- material thickness 4 mm
- with fixing screws

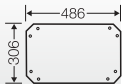

**FP BZ 13**

**Fixing screw**  
**length 13 mm**

- for assembling DIN rails or mounting plates at the base of the box
- for material thicknesses of 2.5 to 4 mm
- self-tapping
- galvanised

Application:



Device installation on mounting plates



**FP AP 10**

**Cover without cut-outs**  
**W 220 x H 130 mm**

- for ENYSTAR enclosure size 1
- for retrofitting
- as protection cover or for installation of equipment



**FP AP 20**

**Cover without cut-outs**  
**W 220 x H 310 mm**

- for ENYSTAR enclosure size 2
- for retrofitting
- as protection cover or for installation of equipment



**FP AP 30**

**Cover without cut-outs**  
**W 220 x H 490 mm**

- for ENYSTAR enclosure size 3
- for retrofitting
- as protection cover or for installation of equipment

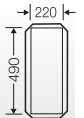

**FP AP 40**

**Cover without cut-outs**  
**W 490 x H 310 mm**

- for ENYSTAR enclosure size 4
- for retrofitting
- as protection cover or for installation of equipment

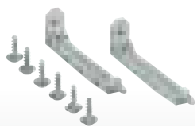
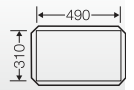

**FP PL 2**

**Sealing device for covers**  
**not suitable for circuit-breaker boxes**

- can be retrofitted
- 2 pieces
- with fixing screws

Application:

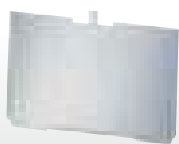

Device installation in covers

**FP TW 18****Partition  
180 mm**

- to push-in between enclosures

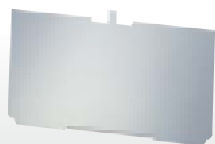
**FP TW 27****Partition  
270 mm**

- to push-in between enclosures

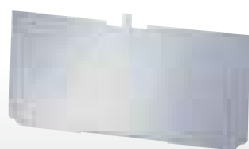
**FP TW 36****Partition  
360 mm**

- to push-in between enclosures
- except between two busbar boxes

**AS 12****Blanking strip  
12 modules**

- 12 x 18 mm, divisible every 9 mm
- for the covering of spare equipment openings, for material thickness up to 3 mm

**AS 18****Blanking strip  
18 modules**

- 18 X 18 mm, divisible every 9 mm
- for the covering of spare equipment openings, for material thickness up to 3 mm

**DAE 12****Spacer**

- for improvement in the heat dissipation of DIN rail mounted devices
- consisting of 12 items



**FC PN 20**

**PE and N terminal**  
**PE/N 2 x 25 mm<sup>2</sup>, 8 x 4 mm<sup>2</sup>, Cu each**

- for installation on DIN rails in accordance with IEC 60715, top hat profile 35 mm
- for boxes with 1 x 12 modules (through terminal reduction to 9 modules)
- FIXCONNECT® plug-in technology, for terminal technology refer to index technical data
- current carrying capacity: 101 A

rated insulation voltage

U<sub>i</sub> = 690 V a.c.



**FP FC 24**

**PE and N terminal**  
**per PE/N 3 x 25 mm<sup>2</sup>, 12 x 4 mm<sup>2</sup>, Cu**

- for enclosures with 2 x 12 modules
- FIXCONNECT® plug-in technology, for terminal technology refer to index technical data
- N separable, for up to 2 different potentials
- with fastening material
- current carrying capacity: 75 A

rated insulation voltage

U<sub>i</sub> = 690 V a.c.

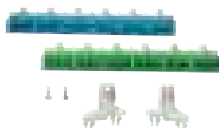

**FP FC 36**

**PE and N terminal**  
**per PE/N 6 x 25 mm<sup>2</sup>, 24 x 4 mm<sup>2</sup>, Cu**

- for enclosures with 3 x 12 modules
- FIXCONNECT® plug-in technology, for terminal technology refer to index technical data
- N separable, up to 4 different potentials
- with fastening material
- current carrying capacity: 75 A

rated insulation voltage

U<sub>i</sub> = 690 V a.c.

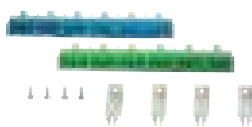

**FP FC 54**

**PE and N terminal**  
**per PE/N 6 x 25 mm<sup>2</sup>, 24 x 4 mm<sup>2</sup>, Cu**

- for enclosures with 2 x 27 modules
- FIXCONNECT® plug-in technology, for terminal technology refer to index technical data
- N separable, up to 4 different potentials
- with fastening material
- current carrying capacity: 75 A

rated insulation voltage

U<sub>i</sub> = 690 V a.c.

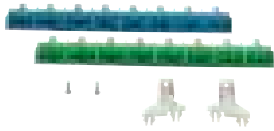

**FP FC 51**

**PE and N terminal  
per PE/N 8 x 25 mm<sup>2</sup>, 32 x 4 mm<sup>2</sup>, Cu**

- for enclosures with 3 x 17 modules
- FIXCONNECT® plug-in technology, for terminal technology refer to index technical data
- N separable, up to 4 different potentials
- with fastening material
- current carrying capacity: 75 A

rated insulation voltage

U<sub>i</sub> = 690 V a.c.



**FC PE 10**

**PE terminal  
2 x 25 mm<sup>2</sup>, 8 x 4 mm<sup>2</sup>, Cu**

- for installation on DIN rails in accordance with IEC 60715, top hat profile 35 mm
- for boxes with 1 x 12 modules (through terminal reduction to 9 modules)
- FIXCONNECT® plug-in technology, for terminal technology refer to index technical data

rated insulation voltage

U<sub>i</sub> = 690 V a.c.

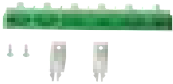
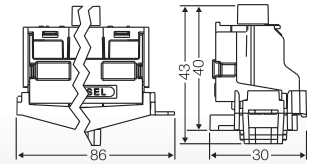

**FP FC 054**

**PE terminal  
6 x 25 mm<sup>2</sup>, 24 x 4 mm<sup>2</sup>, Cu**

- for enclosures with 2 x 12 modules, 3 x 12 modules, 2 x 27 modules
- FIXCONNECT® plug-in technology, for terminal technology refer to index technical data
- with fastening material

rated insulation voltage

U<sub>i</sub> = 690 V a.c.



**FP FC 051**

**PE terminal  
8 x 25 mm<sup>2</sup>, 32 x 4 mm<sup>2</sup>, Cu**

- for enclosures with 3 x 17 modules
- FIXCONNECT® plug-in technology, for terminal technology refer to index technical data
- with fastening material

rated insulation voltage

U<sub>i</sub> = 690 V a.c.



**FC BS 5**

**FIXCONNECT labelling system  
set with 5 pieces**

- labelling system for FIXCONNECT® plug-in terminals, not for terminals 2x25 / 4x4 mm<sup>2</sup>
- for attaching of labelling strips or marking with felt tip pen



**KKL 34**

**Main line branch terminal**

**Rated connecting capacity: 1.5-25 mm<sup>2</sup>, Cu**

- as a connecting terminal
- for installation on DIN rails in accordance with IEC 60715, top hat profile 35 mm
- connections per terminal L1-L3: 4x
- connection: 1.5-16 mm<sup>2</sup> f\* or 2.5-25mm<sup>2</sup>, Cu, round conductor  
f\* = with gas-tight end ferrule
- current carrying capacity: 80 A
- width: 61 mm



dismantling length	19 mm
tightening torque for terminal	2.5 Nm

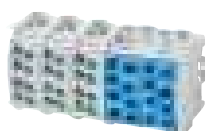

**KKL 48**

**Main line branch terminal**

**Rated connecting capacity: 1.5-25 mm<sup>2</sup>, Cu**

- as a connecting terminal
- for installation on DIN rails in accordance with IEC 60715, top hat profile 35 mm
- connections per terminal L1-L3, 4x  
connections per terminal N: 8x
- connection: 1.5-16 mm<sup>2</sup> f\* or 2.5-25mm<sup>2</sup>, Cu, round conductor  
f\* = with gas-tight end ferrule
- current carrying capacity: 80 A
- width: 100 mm



dismantling length	19 mm
tightening torque for terminal	2.5 Nm



**KKL 54**

**Main line branch terminal**

**Rated connecting capacity: 1.5-25 mm<sup>2</sup>, Cu**

- as a connecting terminal
- for installation on DIN rails in accordance with IEC 60715, top hat profile 35 mm
- connections per terminal L1-L3: 4x  
connections per terminal N: 4x  
connections per terminal PE: 4x
- connection: 1.5-16 mm<sup>2</sup> f\* or 2.5-25mm<sup>2</sup>, Cu, round conductor  
f\* = with gas-tight end ferrule
- current carrying capacity: 80 A
- width: 100 mm

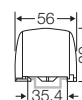

dismantling length	19 mm
tightening torque for terminal	2.5 Nm

**FP WT 1****Wall separator**

- for connecting enclosure walls of different sizes (refer to technical data)
- for insertion in bases of enclosures
- with 2 fixing elements

**FP VP 18****Closing plate  
180 mm**

- with 2 fixing elements
- without knockouts

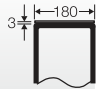
**FP VP 27****Closing plate  
270 mm**

- with 2 fixing elements
- without knockouts

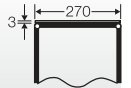
**FP VP 36****Closing plate  
360 mm**

- with 2 fixing elements
- without knockouts

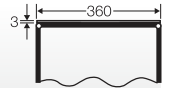

Application:



Closing of enclosure walls

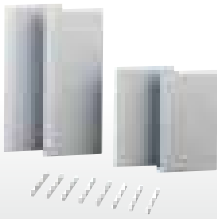

**FP VS 10**  
**Closing plate set**  
**box size 1**

- 2 x for box wall 1 (180 mm) and 2 x for box wall 2 (270 mm)
- with 8 fixing elements
- without knockouts

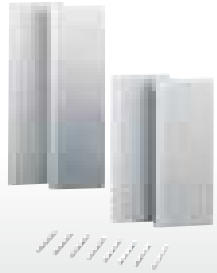

**FP VS 20**  
**Closing plate set**  
**box size 2**

- 2 x for box wall 2 (270 mm) and 2 x for box wall 3 (360 mm)
- with 8 fixing elements
- without knockouts

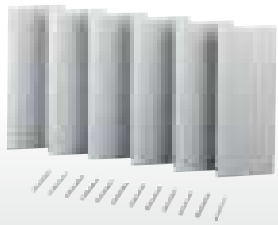

**FP VS 30**  
**Closing plate set**  
**box size 3**

- 6x for box wall 2 (270 mm)
- with 12 fixing elements
- without knockouts



**FP VS 40**  
**Closing plate set**  
**box size 4**

- 4 x for box wall 2 (270 mm) and 2 x for box wall 3 (360 mm)
- with 12 fixing elements
- without knockouts

Application:



Closing of enclosure walls



**FP VM 27**

**Metal insert for closing plates**

- box size 2 (270 mm)
- for earthing of metal armoured cables
- without knockouts

mounting width	180 mm
mounting height	80 mm

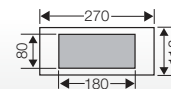

**FP VM 36**

**Metal insert for closing plates**

- for box wall 3 (360 mm)
- for earthing of metal armoured cables
- without knockouts

mounting width	270 mm
mounting height	80 mm

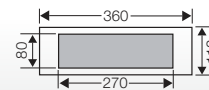

Application:



Metal insert for earthing of metal armoured cables



Earth connection according to British Standard installation via built-in metal insert.

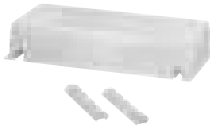

**FP FG 200**

**Flange  
without knockouts**

- box size 2 (270 mm)
- attached enclosure connectors: 2 items

mounting width	240 mm
mounting height	92 mm

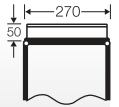

**FP FG 222**

**Flange  
sealing range Ø 6-30 mm**

- sealing range: 17 x Ø 6-13 mm, 2 x Ø 9-17 mm, 2 x Ø 8-23 mm, 1 x Ø 11-30 mm
- box size 2 (270 mm)
- attached enclosure connectors: 2 items
- with integrated grommets for cable entry

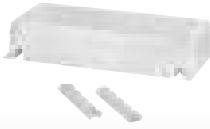
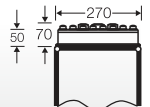

**FP FM 225**

**Flange  
knockouts: 7 x M 16/25, 13 x M 20/25**

- box size 2 (270 mm)
- attached enclosure connectors: 2 items

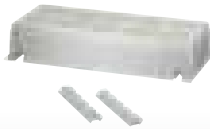
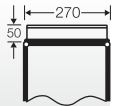

**FP FM 232**

**Flange  
knockouts: 8 x M 25/32, 2 x M 25/32/40**

- box size 2 (270 mm)
- attached enclosure connectors: 2 items

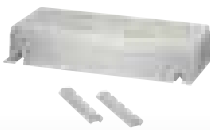
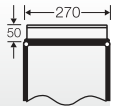

**FP FM 240**

**Flange  
knockouts: 2 x M 25/32, 5 x M 25/32/40**

- box size 2 (270 mm)
- attached enclosure connectors: 2 items

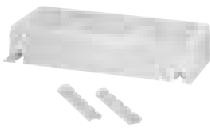
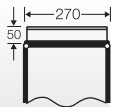

**FP FM 263**

**Flange  
knockouts: 2 x M 20, 2 x M 25/32,  
2 x M 32/40/50, 1 x M 40/50/63**

- box size 2 (270 mm)
- attached enclosure connectors: 2 items

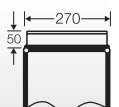

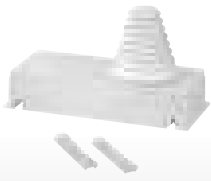

**FP FG 272**

**Flange**  
**sealing range: 1 x Ø 30-72 mm**

- box size 2 (270 mm)
- attached enclosure connectors: 2 items

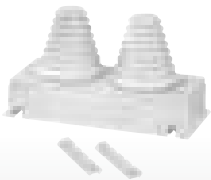
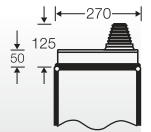

**FP FG 273**

**Flange**  
**sealing range: 2 x each Ø 30-72 mm**

- box size 2 (270 mm)
- attached enclosure connectors: 2 items

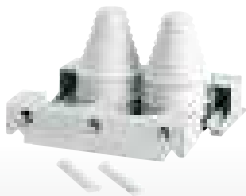
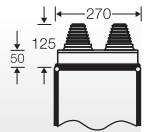

**FP FG 282**

**Cable insert**  
**sealing range: 2 x each Ø 30-72 mm**

- divisible for cable insertion from the front
- box size 2 (270 mm)
- attached enclosure connectors: 2 items
- degree of protection IP 65 only with additional strain and pressure relief (e.g. FP ZE 272)

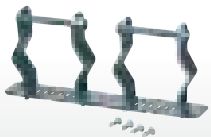

**FP ZE 272**

**Cable strain relief**  
**for 2 cables with max. 60 mm external diameter**

- box size 2 (270 mm)
- with fixing screws



**FP GS 27**

**Box fin**  
**for inserting cables across 2 boxes**

- removable
- for box walls 270 mm
- can be retrofitted

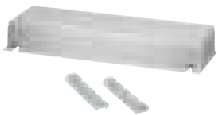

**FP FG 300**

**Flange**  
**without knockouts**

- for box wall 3 (360 mm)
- attached enclosure connectors: 2 items

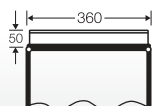

mounting width	330 mm
mounting height	92 mm



**FP FG 331**

**Flange**  
**sealing range Ø 6-30 mm**

- sealing range: 22 x Ø 6-13 mm, 6 x Ø 9-17 mm, 2 x Ø 8-23 mm, 1 x Ø 11-30 mm
- for box wall 3 (360 mm)
- attached enclosure connectors: 2 items
- with integrated grommets for cable entry

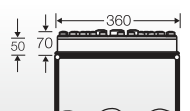



**FP BF 18**

**Ventilation flange  
180 mm**

IP  
44

- for ventilation of ENYSTAR Distribution boards in the event of extremely high internal temperatures or a risk of water condensation
- for vertical installation on box walls
- with 2 fixing elements



**FP BF 27**

**Ventilation flange  
270 mm**

IP  
44

- for ventilation of ENYSTAR Distribution boards in the event of extremely high internal temperatures or a risk of water condensation
- for vertical installation on box walls
- with 2 fixing elements



**FP BF 36**

**Ventilation flange  
360 mm**

IP  
44

- for ventilation of ENYSTAR Distribution boards in the event of extremely high internal temperatures or a risk of water condensation
- for vertical installation on box walls
- with 2 fixing elements



**BE 44**

**Ventilation insert**

IP  
44

Application

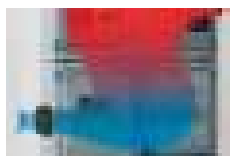

Ventilation via ventilation insert



**BM 20G**

**Pressure compensation element for M 20 knockouts**

- for the reduction of condensation by pressure compensation in power distribution systems
- ISO thread M 20 x 1.5
- bore-hole: Ø 20.3 mm
- wall thickness up to 4 mm
- with counter nut
- for indoor (normal environment and/or protected outdoor) and outdoor installation (harsh environment and/or outdoor)
- ambient temperature - 25 °C to + 55 °C
- In order not to exceed leakage limit of 0.07 bar with pressure compensation, one pressure compensation element BM 20G must be used per 28 litres (28000 cm³) of enclosure volume.
- Example: enclosure size 30 cm x 60 cm x 17 cm = 30600 cm³ = 30,6 litres. Number of necessary BM 20G (M32) = 2 piece.
- technical changes reserved
- Colour: grey, RAL 7035

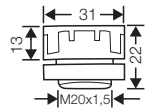

**BM 40G**

**Pressure compensation element for M 40 knockouts**

- for the reduction of condensation by pressure compensation in power distribution systems
- ISO thread M 40 x 1.5
- bore-hole: Ø 40.3 mm
- wall thickness of up to 8 mm
- with counter nut
- for indoor (normal environment and/or protected outdoor) and outdoor installation (harsh environment and/or outdoor)
- ambient temperature - 25 °C to + 55 °C
- In order not to exceed leakage limit of 0.07 bar with pressure compensation, one pressure compensation element BM 40G must be used per 122 litres (122000 cm³) of enclosure volume.
- Example: enclosure size 60 cm x 60 cm x 17 cm = 61200 cm³ = 61,2 litres. Number of necessary BM 40G (M40) = 1 piece.
- technical changes reserved
- Colour: grey, RAL 7035

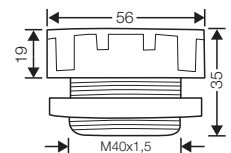

Pressure compensation element





**FP DB 27**  
**Canopy**  
**for box wall 270 mm**

- W 270 x D 245 mm
- attached enclosure connectors: 2 items

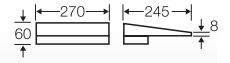

material	stainless steel powder-coated
----------	----------------------------------

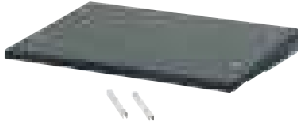

**FP DB 36**  
**Canopy**  
**for box wall 300 mm**

- W 360 x D 245 mm
- attached enclosure connectors: 2 items

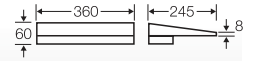

material	stainless steel powder-coated
----------	----------------------------------



**Mi DB 01**  
**Canopy end plate**

- for canopies FP DB xx and Mi DB xx

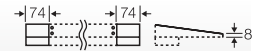

material	stainless steel powder-coated
----------	----------------------------------

Application:



Canopy



**FP GV 10**

**Connector**

- when converting existing installations
- for connection of enclosures or fixation of flanges
- set with 10 pieces



**FP PL 3**

**Facility for sealing**

- for door sealing
- can be retrofitted
- 2 pieces



**FP TW 1**

**Tool operation  
conversion kit from hand to tool operation**

- can be retrofitted



**FP TS 1**

**Door lock  
converting kit to key operation**

- for subsequent installation in hand operated door locking system



**FP TS 2**

**Spare key**

- for door lock FP TS 1
- 2 pieces

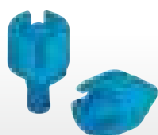

**FP TW 2**

**Tool key for double-bit  
conversion kit to tool operation**

- can be retrofitted

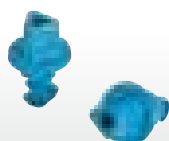

**FP TW 3**

**Tool key for triangular lock, 8 mm  
conversion kit to tool operation**

- can be retrofitted

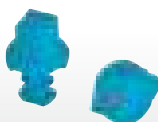

**FP TW 4**

**Tool key for square lock, 8 mm  
conversion kit to tool operation**

- can be retrofitted

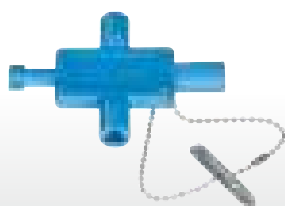

**US 1**

**Multikey**

- triangular 8 mm, square 8 mm, double-bit and slot



**FP AL 40**

**4 stainless steel external brackets**

- for external fixing of enclosures

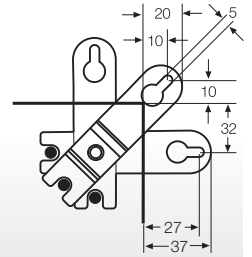

**FP MS 1**

**Profile for wall mounting**

- for ENYSTAR distribution board assemblies up to 810 x 1260 mm
- with 8 screws, washers and nuts for fastening of enclosures

length	1980 mm
material	sendzimir galvanised steel profile with structured powder coating

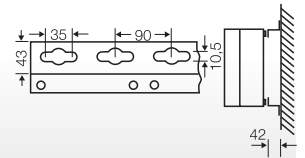

**Varnishing pen RAL 7016**

**12 ml**



## ENYSTAR

### Technical details

Operating and ambient conditions	283
Detail dimensions in mm	284 - 285
Rated power dissipation of empty boxes	286 - 287
Standards and regulations	288
Assembly	289 - 293
Wall mounting	294
Device installation, wiring	295 - 297

	Enclosures with door and closing plates Empty enclosures FP 0...	Circuit breaker boxes FP 1...
<b>Application area</b>	<b>Suitable for indoor installation and outdoor installation, protected against weather influences</b> However, pay attention to the climatic effects on the installed equipment, for example, high or low ambient temperatures or formation of condensed water see technical information	
<b>Ambient temperature</b> - Average value over 24 hours - Maximum value - Minimum value	- + 70 °C - 25 °C	+ 35 °C The ambient temperature for enclosures with electrical functions (distribution boards) is reduced by the installed equipment technology! + 40 °C - 5 °C
<b>Relative humidity</b> - short-time	Adhere to the assembly instructions issued by the manufacturer.	50% at 40 °C 100% at 25 °C
<b>Fire protection</b> in the event of internal faults	Demands placed on electrical devices from standards and laws:  Minimum requirements - Glow wire test in accordance with IEC 60 695-2-11: - 650 °C for boxes and cable glands - 850 °C for conducting components	
<b>Burning behaviour</b> - Glow wire test IEC 60 695-2-11 - UL Subject 94	960 °C V-2 flame-retardant self-extinguishing	960 °C V-2 flame-retardant self-extinguishing
<b>Degree of protection against mechanical load</b>	IK 08 (5 Joule)	IK 08 (5 Joule)
<b>Toxic behaviour</b>	halogen-free <sup>1)</sup> silicone-free	halogen-free <sup>1)</sup> silicone-free

<sup>1)</sup> "Halogen-free" in accordance with IEC 60754-2 "Common test methods for cables - Determination of the amount of halogen acid gas".

**For material properties see technical data.**

 = usable installation space with mounted cable glands

ENYSTAR distribution boards with door lockings for hand operation and closing plates

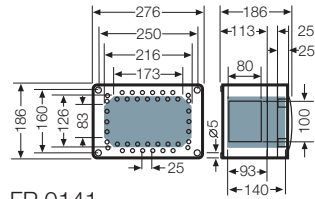

FP 0141  
FP 0151

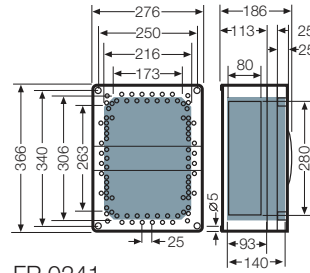

FP 0241  
FP 0251

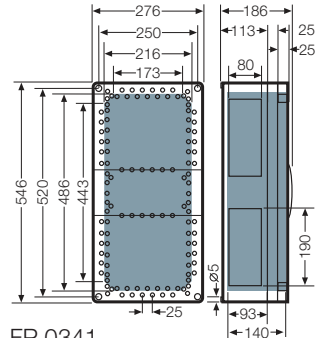

FP 0341  
FP 0351

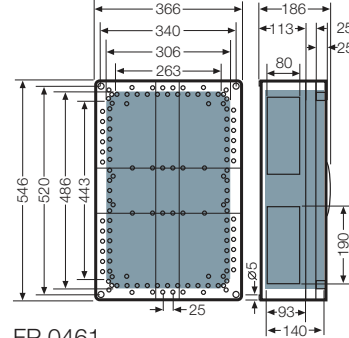

FP 0461  
FP 0471

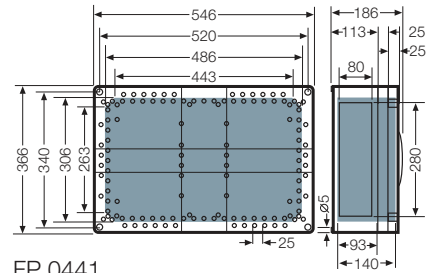

FP 0441  
FP 0451

ENYSTAR distribution boards with door lockings for hand operation

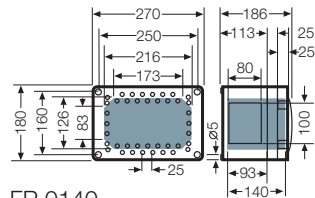

FP 0140  
FP 0150

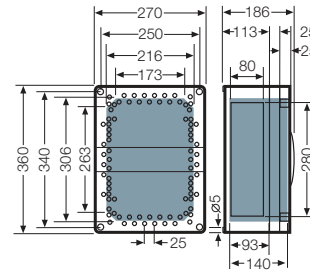

FP 0240  
FP 0250

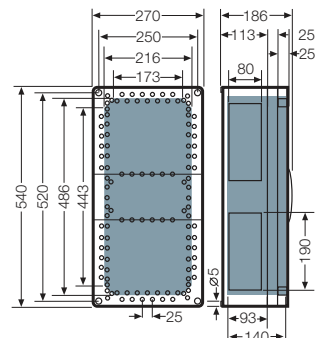

FP 0340  
FP 0350

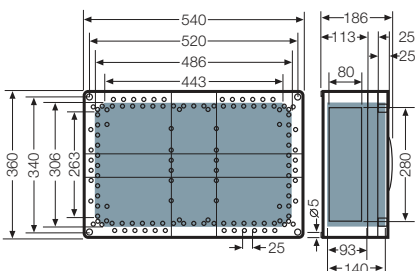

FP 0440  
FP 0450

Mounting depth for device installation in covers

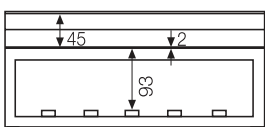

Technical details  
Detail dimensions in mm

 = usable installation space with mounted cable glands

ENYSTAR distribution boards with door lockings for tool-operation and closing plates

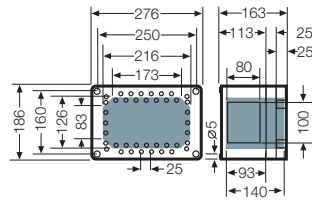

FP 0101  
FP 0121

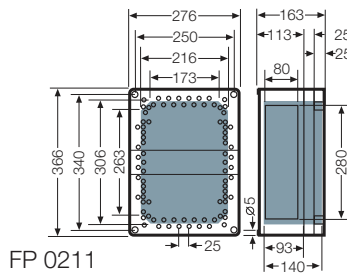

FP 0211  
FP 0231

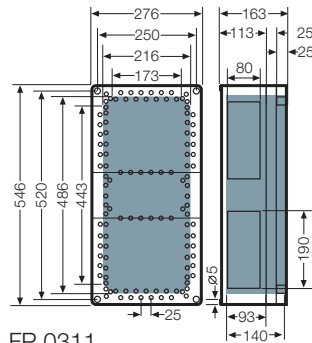

FP 0311  
FP 0331

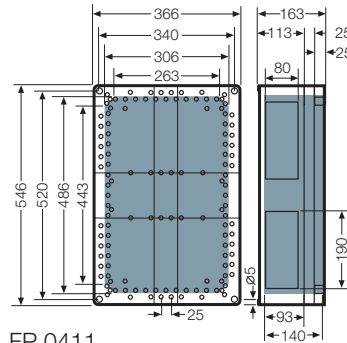

FP 0411  
FP 0431

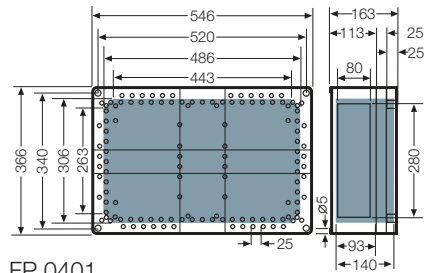

FP 0401  
FP 0421

ENYSTAR distribution boards with door lockings for tool-operation

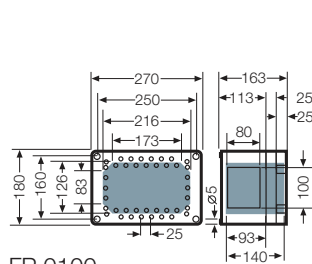

FP 0100  
FP 0120

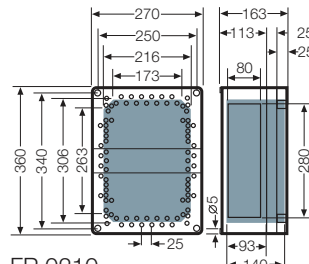

FP 0210  
FP 0230

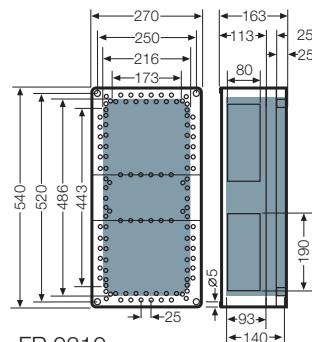

FP 0310  
FP 0330

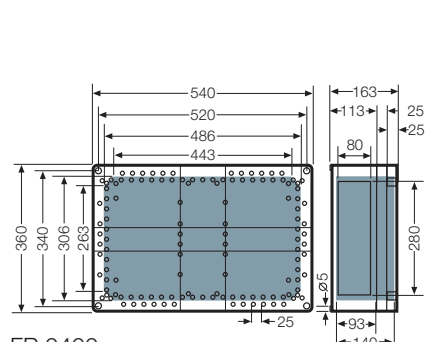

FP 0400  
FP 0420

Mounting depth for device installation in covers

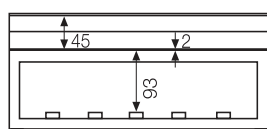

Temperature rise ( $\Delta\theta$ ) with ENYSTAR enclosures by power dissipation of electrical devices

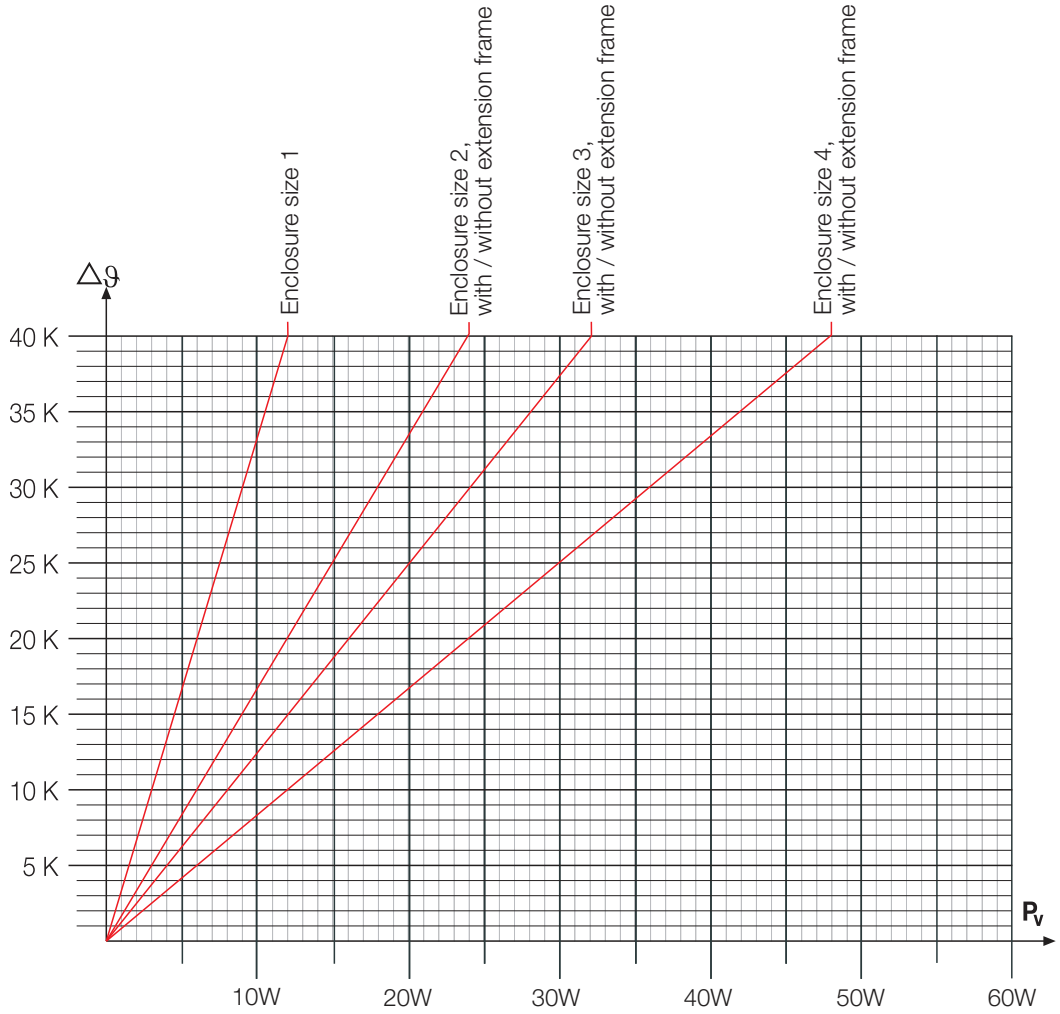

ENYSTAR distribution boards	Dimensions (WxH) in mm	Rated power dissipation $P_{ab}$ in watts per kelvin assembled enclosures
Enclosure size 1	270 x 180	0.3
Enclosure size 2 with / without extension frame	270 x 360	0.6
Enclosure size 3 with / without extension frame	270 x 540	0.8
Enclosure size 4 with / without extension frame	540 x 360	1.2

**Note!**

**The maximally permissible operating temperature inside the enclosures ( $\vartheta_{i\max}$ ) is determined by:**

- 1<sup>st</sup> Maximally permissible ambient temperature of the installed electrical devices (please consider data of the equipment manufacturers)
- 2<sup>nd</sup> Category temperature of the internal wiring and the inserted cables
- 3<sup>rd</sup> Temperatur resistance of the enclosure materials and the cable entries etc.

<b>Example: calculation of the maximum rated power dissipation (<math>P_V</math>)</b>	
maximally permissible operating temperature inside the enclosure(s) ( $\vartheta_{i\max}$ ):	e.g. 55 °C
ambient temperature of the enclosure(s) ( $\vartheta_U$ ):	25 °C
maximally permissible heating up inside the enclosure:	$\Delta\vartheta = \vartheta_{i\max} - \vartheta_U = 55\text{ °C} - 25\text{ °C} = 30\text{ K}$
maximum permissible power dissipation of the installed equipment inclusive wiring ( $P_V$ ) in accordance with diagram: enclosure size 3 (540 x 270 x 163 mm):	
enclosures in assemblies:	$P_V = 24\text{ W}$

<b>Example: calculation of the operating temperature inside the enclosure (<math>\vartheta_i</math>)</b>	
ambient temperature of the enclosure(s) ( $\vartheta_U$ ):	25 °C
rated power dissipation of the installed electrical equipment ( $P_V$ ):	24 W
heating up inside the enclosures in accordance with diagram over:	$\Delta\vartheta$
enclosure size 3 (540 x 270 x 163 mm): assembled enclosures:	$\Delta\vartheta = 30\text{ K}; \vartheta_i = \vartheta_U + \Delta\vartheta = 25\text{ °C} + 30\text{ K} = 55\text{ °C}$

**ENYSTAR distribution boards comply with the requirements of the IEC 61439-3**

Distribution boards assembled and wired according to manufacturer data without essential deviations from the original type or system.

To meet these requirements for Hensel ENYSTAR Distribution boards, the following must be noted:

1. The distribution boards must consist of the verified enclosures documented in this list.
2. The wiring of the equipment must be carried out with the cross-sections and conductor types indicated in Table "Rating of insulated conductors in switchgear assemblies", Index Technics.
3. Once the distribution board is completed, a routine test must be carried out in accordance with this standard.
4. The test must be certified with a test report.
5. The assembly must be provided with a manufacturer's identification mark.  
Compliance with important data such as
  - limit of temperature rise
  - dielectric strength
  - IP degrees of protection
  - creepage distances and clearances
 is verified for this system.

**Standards and regulations**

- IEC 61439-3  
... low-voltage switchgear and controlgear assemblies intended to be in places where unskilled persons have access to their use - distribution boards
- IEC 60999, connecting devices  
Safety requirements for screw-type and screwless-type clamping units for electrical copper conductors
- DIN EN 50262  
Metric threaded cable glands for electrical installations
- DIN 43880  
Built-in equipment for electrical installations; overall dimensions and related mounting dimensions
- IEC 60529 / DIN VDE 0470 Part 1  
Degrees of protection provided by enclosures (IP-Code)

Combination of enclosures  
 with connectors and wall  
 separators

At this point a wall separator is necessary for the enclosure combination.

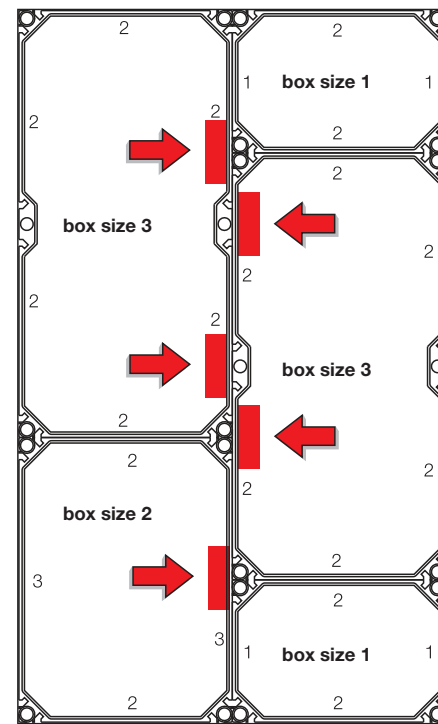
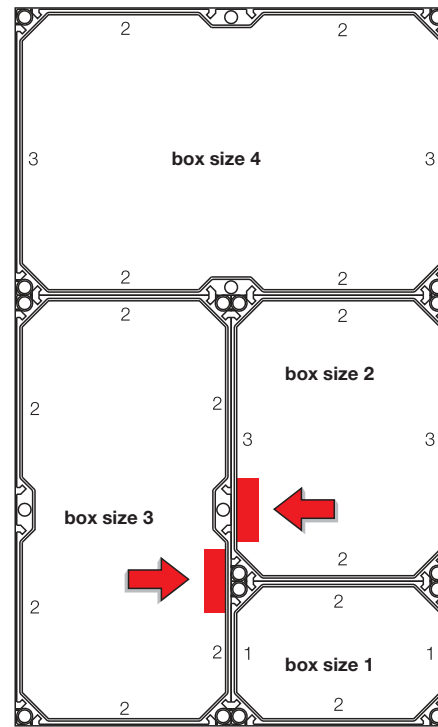
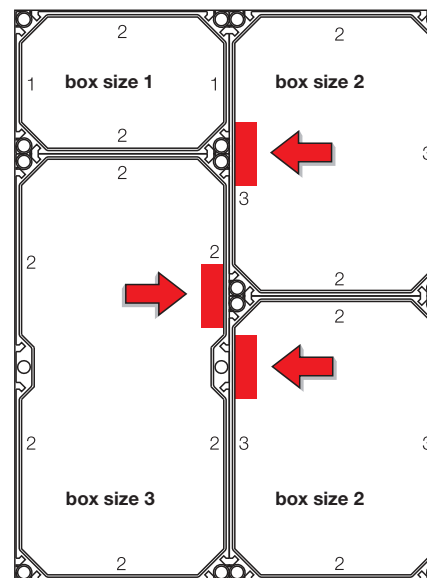
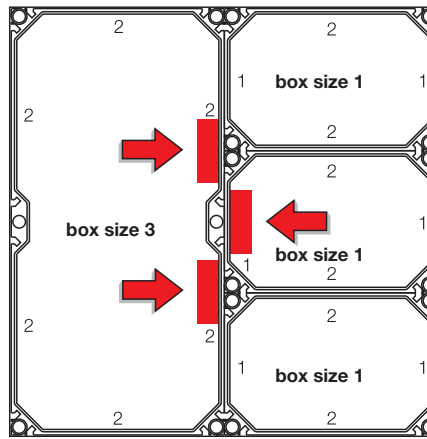
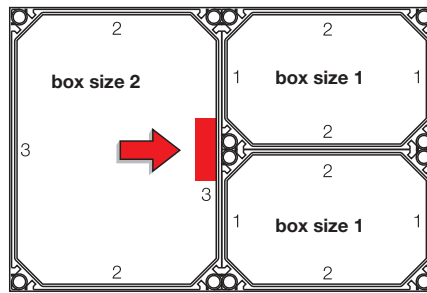

Fast assembly and mounting

All necessary gaskets are integral part of the enclosures. The enclosures are interconnected among themselves by easily pushing-in of connectors. No tools are necessary.

Connectors are attached to the enclosures in sufficient number. For reconstruction or extensions of existing distribution boards connectors FP GV 10 (set consists of 10 pieces) can be supplemented.

The connection of enclosures is not only co-ordinated with enclosures of the same size.

By means of wall separators also different sized enclosures can be combined.

Wall separators provide for high rigidity and tightness at the connection points of the enclosures, degree of protection IP 66.

**Connection of enclosures**

Assemble enclosures by pushing-in enclosed connectors.

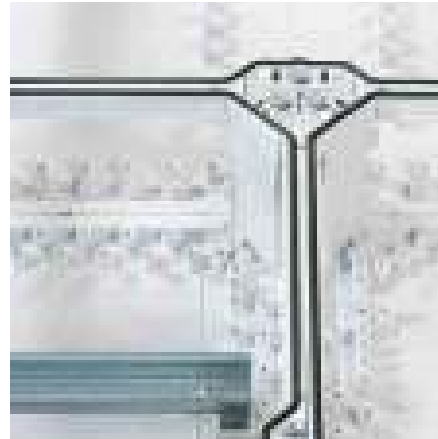

**Inserting wall separators**

Use wall separators to connect different sized enclosure walls.



**Closing walls via closing plates**

Insert closing plates into openings of outer walls of the distribution board and fix them with enclosure connectors.



**Cable entry - opening knockouts in flanges**

Knock out the appropriate cable entries within flanges with screwdriver.



**Cable glands**

Insert cable gland into the appropriate knockout and fasten with lock nut.



**Closing of enclosure walls with flanges for cable entry**

Insert flanges for cable entry into open outer walls of the distribution board and fix them with enclosure connectors.

A wide range of flanges for the cable entry is available.



**Installation of cable inserts**

Saw the box fin.  
 Afterwards the cable insert is mounted and fixed via enclosure connectors and the rubber entries can be inserted.



Adjust stepped grommet on the cable diameter.

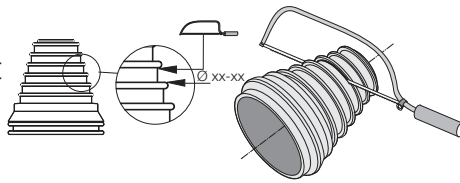

Insert cable and fix it with the cable ties.

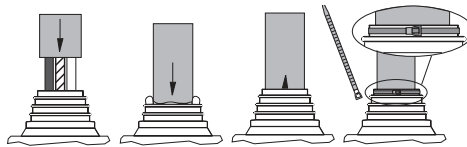

Insert the cable into the box from the front.



**Box fin**

provides an easier wiring across two boxes.

Saw out fin in box wall.

Insert box fin and fix via fixing wedges.



**Installation of extension frame**

Fix attachments for extension frame in base of enclosure. Place extension frame on base of enclosure and screw it.



Support for protection cover is adjustable in height.



Click protection cover into place depending on the height of the electric devices (height adjustable).



**FP ZR ..**

Extension frame for extension of the installation depth by 50 mm

**External brackets made from stainless steel**  
 for external box fixing



**FP AL 40** (4 pieces)

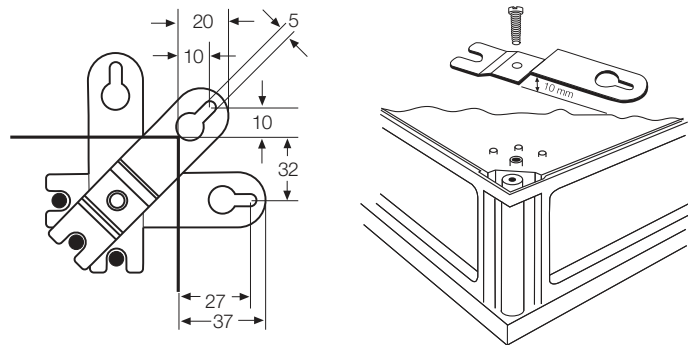

**Mounting profile**  
 for wall-mounting of  
 ENYSTAR distribution boards,  
 steel profile,  
 length 1980 mm  
**FP MS 1**



**Fixing matrix of mounting profile**

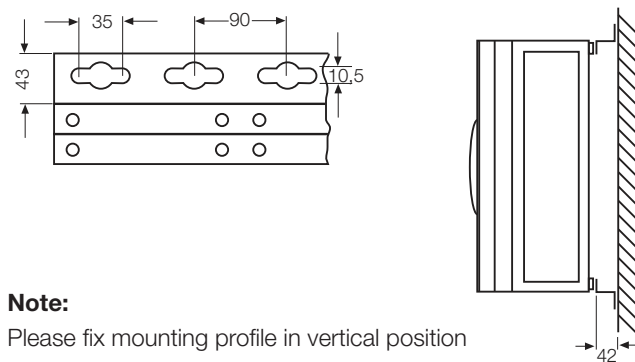

**Note:**  
 Please fix mounting profile in vertical position as possible in order to give occasion to cable routing behind the assembly.

For cutting to the required length fix mounting profile for example with a clamp to a desk.

**Transport**  
 Regarding transportation it is recommendable to protect the assembly against deflection. For that please screw the assembly to a solid timber.

**Device installation on mounting plates or DIN rails**

Fix installation devices on mounting plate via self-threading screws.

Using screws for fixing mounting plates onto bottom of boxes.



Mount DIN-rails right away on the bottom of bases or via spacers in heights of 29.5 mm or 53.5 mm.



**Device installation into covers**

Pre-drill the cut-outs at the corners and saw them out of the cover.

Use a piercing saw with coarse toothed saw blade for plastics. Install device.



Snap cover into door frame from the rear.

Afterwards, screw door-frame with door and cover onto base of enclosure.

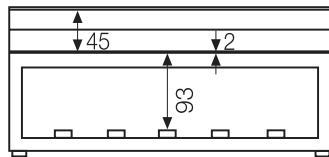

Installation depth for equipment installation in covers

**Sealing**

For installation in all enclosures except circuit breaker boxes.

Sealing device is screwed on enclosure bottom.

Open pre-moulded opening for sealing device (drill Ø 5 mm) and screw the cover with frame.



Then screw the frame with door and cover onto base of enclosure.

Seal the cover.



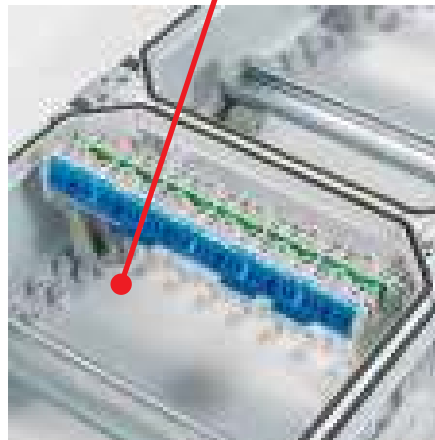
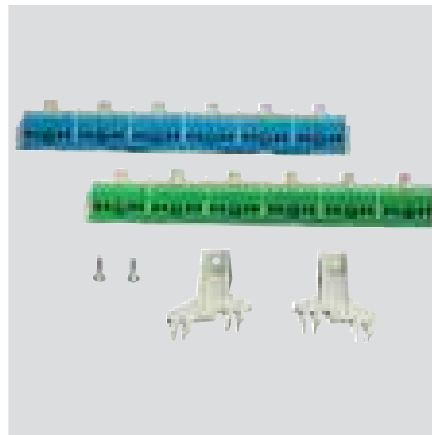

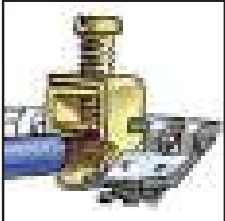
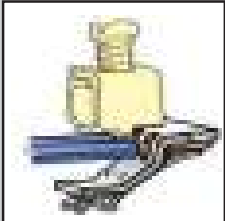
Clamping unit	Corresponding cross-sections/copper			
	max. number	from - to max.	max. number	from - to max.
Screw-type terminal 25 mm <sup>2</sup>				
	1	25 mm <sup>2</sup> , s	1	25 mm <sup>2</sup> , f
	1	16 mm <sup>2</sup> , s	1	16 mm <sup>2</sup> , f
	1	10 mm <sup>2</sup> , sol	1	10 mm <sup>2</sup> , f
	3	6 mm <sup>2</sup> , sol	1	6 mm <sup>2</sup> , f
	3	4 mm <sup>2</sup> , sol	1	4 mm <sup>2</sup> , f
	4	2.5 mm <sup>2</sup> , sol	1	2.5 mm <sup>2</sup> , f
	4	1.5 mm <sup>2</sup> , sol	1	1.5 mm <sup>2</sup> , f
		} Tested as connecting terminal for several conductors of the same cross-sections for using in one circuit		
Plug-in terminal 4 mm <sup>2</sup>				
	1	1.5 - 4 mm <sup>2</sup> , sol	1	1.5 - 4 mm <sup>2</sup> , f
				Without end ferrule; clamping unit has to be opened with a tool when conductor is inserted

**Current carrying capacity of the connecting device: 75 A**  
All terminals are secured against self loosening.



enymod

Mi Power  
distribution boards

## Mi Power distribution boards up to 630 A

in accordance with IEC 61439-2

- combinable enclosure system
- degree of protection IP 65
- made from polycarbonat
- protection class II, 

IEC 61439-2:

Interface characteristics of an assembly and changes facing manufacturer's of an assembly (Panel builder)	300 - 301
System description	302 - 307
Overview product range	308 - 309
<b>Empty boxes</b>	310 - 316
<b>Empty boxes with hinged lids</b>	317 - 321
<b>Circuit breaker boxes</b>	
9 - 84 modules, with PE and N terminals	322 - 325
12 - 48 modules with hinged flaps, with PE and N terminals	326
12 - 84 modules, without PE and N terminals	327 - 329
12 - 48 modules, with hinged flaps, without PE and N terminals for miniature circuit breakers (MCB)	330 - 331
	332
12 - 84 modules, without PE and N terminals, with removable DIN rail rack and earth connection	333 - 335
12 - 48 modules with hinged flaps, without PE and N terminals, with removable DIN rail rack and earth connection	336 - 337
Accessories	338 - 360
Technical details	361 - 373

Further technical information can be found on the Internet  
[www.hensel-electric.de](http://www.hensel-electric.de) -> Products

**Standard-conforming rating according to IEC 61439-2**

The new IEC 61439 - the standard for the construction of switchgear assemblies - brings changes that affect the planning of a switchgear assembly. In addition, new tasks and responsibilities are awaiting the manufacturer of a switchgear assembly.

Decisive for the optimal functioning of a switchgear assembly under operating conditions is the correct rating of the interface characteristics of the assembly. For this purpose, the assembly is considered as **BLACK-BOX** with four interface characteristics which shall ensure compatibility with the ratings of the circuits to which it is connected and the installation conditions and shall be declared by the assembly manufacturer using the criteria identified below.

**Assembly considered as BLACK BOX with the four interface characteristics according to IEC 61439-2**



**Installation and ambient conditions**

- For the protected outdoor installation
- Degree of protection IP 65
- Combinable enclosure system, extendable in all directions
- 6 enclosure sizes in a grid of 150 mm
- EMC compliant busbar system
- Wall-mounting or floor-standing



**Operation and maintainance**

- Electrical functions intended to be operated by electrotechnical skilled or unskilled persons
- Protection class II up to a rated current of 630 A
- Flexible by standardised and tested kits
- Spacious connection areas

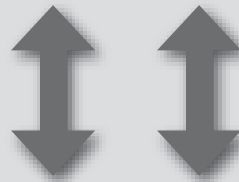

**BLACK BOX with 4 interfaces**



Mi Power Distribution Board (PSC)

Combinable enclosure system, insulation-enclosed, total insulated, degree of protection IP 65, for the assembly of power switchgear and controlgear assemblies (PSC) up to 630 A in accordance with IEC 61439-2.

The requirements for all installed electrical functions within the assembly have been proved compliance with the applicable requirements of IEC 61439-2.

$I_{nc}$  and RDF must be specified in the documentation.

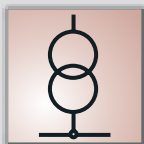

**Connection to the electrical network**

- Electric circuit / final circuit
- Circuit-breaker up to 630 A
- Switch disconnector up to 630 A
- Fuse switch disconnector up to 630 A
- Bus-mounted fuse base up to 63 A
- Connection with cable from above / from below
- Connection: conductors from copper / aluminium
- Optional connection of CEE sockets according to EN 60309 and sockets with earthing contact



**Circuits and consumers**

- Rated voltage  $U_n = 690$  V a.c. / 1000 V d.c.
- Rated current  $I_n$  up to 630 A
- Circuit-breaker up to 630 A
- Switch disconnector up to 630 A
- Fuse switch disconnector up to 630 A
- 5-conductor system
- Connector with cable from above / from below



**Changes facing the manufacturer of a switchgear assembly (Panel builder)**

IEC 61439 - the standard for the assembly of switchgear assemblies and distribution boards - determines the safety requirements for electrical equipment for the compliance of protection objectives for people and facilities. Requirements for products are more clearly defined and a new terminology is introduced.

**BLACK BOX Specification**

The designer specifies a switchgear assembly by defining the interface parameters as BLACK BOX. Based on these interface specifications the manufacturer of a switchgear assembly has to rate and define the structure of the switchgear assembly.

**Product presentation in media changed significantly**

The standard has an effect as well on the documentation of products. Additional information, such as the rated current of circuits and the number of circuits, are now listed for each product as they are now required by designers and manufacturers for the construction of switchgear assemblies.

**The international catalogue presents Mi empty and circuit breaker boxes.**

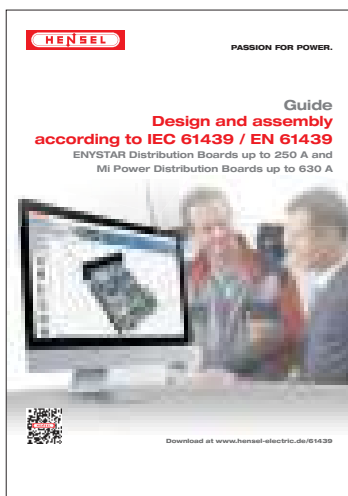

Further enclosures with electrical functions for the assembly of ENYSTAR distribution boards up to 250 A, for example, with built-in busbars, circuit breakers, etc., see at: [www.hensel-electric.de](http://www.hensel-electric.de)

**For design and assembly according IEC 61439 / EN 61439 with ENYSTAR Distribution Boards up to 250 A please refer to the guide at [www.hensel-elctric.de/61439](http://www.hensel-elctric.de/61439).**

The guide to design and assemble in accordance with EN 61439 for ENYSTAR distribution boards up to 250 A and Mi Power distribution boards up to 630 A can be downloaded:



[www.hensel-electric.de/en](http://www.hensel-electric.de/en)

**ENYGUIDE**

Planning tool Configurator ENYGUIDE at [www.enyguide.de](http://www.enyguide.de)

Free planning software ENYGUIDE: allows the quick and easy configuration of distribution boards.



- Dimensional drawings and parts lists are automatically created by ENYGUIDE.
- Representation of the distribution board as a detailed 3D-image or a 2D-drawing.
- Various view planes show the equipment, covers and doors.
- ENYGUIDE determines the necessary accessories such as the number of wall separators independently.
- No time-consuming program installation is needed.

[www.enyguide.de](http://www.enyguide.de)

**Mi Power distribution boards up to 630 A**

combinable enclosure system, insulation-enclosed, total insulated, degree of protection IP 65, for the assembly of power switchgear and controlgear assembly (PSC) up to 630 A in accordance with IEC 61439 Part 2

- Boxes can also be used as a single box
- Degree of protection IP 65: dust-proof and jet water-proof
- Application area: Mi enclosures are suitable for for the protected outdoor installation - harsh environment and /or outdoor.

**Material:**

- Polycarbonate
- Burning behaviour: Glow wire test in accordance with IEC 60 695-2-11, self-extinguishing, flame-retardant
- UV-resistance in accordance with IEC 61439-1, Clause 10.2.4: The material is examined for UV resistance.
- Toxic behaviour: silicone- and halogen-free
- Chemical resistance:  
resistant against acid, lye, benzene and mineral oil



Power distribution board (PSC) in accordance with IEC 61439-2



Safe in dust, dirt, moisture and in harsh industrial atmosphere



Dust- and waterresistant:  
Mi Distribution Boards can withstand the highest loads



Assembly of Mi Distribution boards in accordance with IEC 61439-2

**Enclosure system:**

- Enclosures with electrical functions with standardized kits up to 630 A
- Covers made from thermoplastic
- Covers with protected, editable and captive labelling strips
- Cover plates for mounted electrical equipment
- Mounting plates or DIN rails for installation device
- Large wall openings enable the wiring within the distribution boards
- Cable entry via metric knockouts in all box walls, via flanges with metric knockouts or elastic membranes or cable inserts with up to 74 mm cable diameter
- Wall fixing right away in the boxes, via external brackets or via mounting profiles
- Facility for lead seal and locking
- Hinges for lids and heavy-duty hinge joints for operating installation device within a large area
- Connection Box for the installation of devices that must be operated externally, such as plugs, pushbuttons and switches
- Mi empty boxes and single empty boxes conform to the RoHS Directive 2011/65/EC

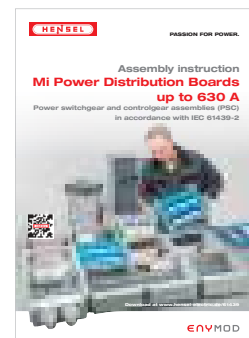

**Assembly instruction**  
Please request or download information:  
[www.hensel-electric.de/en](http://www.hensel-electric.de/en) -> Downloads

# Dependent on the system

## Electrical parameters



Electrical parameters

rated voltage: max. 690 V a.c.  
 rated insulation voltage: 690 V a.c., 1000 V d.c.  
 rated current: max. 630 A  
 rated short-time withstand current: max. 21 kA

The design values are possibly reduced by the installed equipment technology, please refer to technical data of the product or index technical data.

## System properties



Environmental conditions

Ambient temperature  
 - for distribution boards  
 in accordance with IEC 61439:  
 -5 °C up to 35 °C, max. + 40 °C  
 Relative humidity: 50% at 40 °C, 100% at 25 °C

- for empty enclosures: - 25 °C up to + 70 °C  
 The climatic influences and effects on the equipment are to be considered, see technical details / operating and ambient conditions



Application area

The enclosures are suitable for outdoor installation, protected against weather influences.

However, pay attention to the climatic effects on the installed equipment, see operating and ambient conditions in index technical data.



Insulation

insulated enclosures (protection class II)



Impact strength

degree of protection against mechanical load IK 08 (5 Joule) in accordance with IEC 62262



Protection against foreign solid objects and direct contact

dust-proof degree of protection IP 65



Protection against ingress of water with harmful effects

protected against water degree of protection IP 65

Single enclosures without any flanges and components mounted in the lid have degree of protection IP 66

# Dependent on material

## Material properties: polycarbonate



Burning behaviour

glow wire test 960 °C  
 in accordance with IEC 60695-2-11  
 flame-retardant, self-extinguishing



Chemical resistance

resistance against acid 10% and alkaline 10%, petrol and mineral oil



UV resistance

UV resistance according to IEC 61439-1, Section 10.2.4: the material is examined for UV resistance

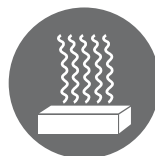

Toxic behaviour

silicone- and halogen-free

Tested and certified  
by ASTA

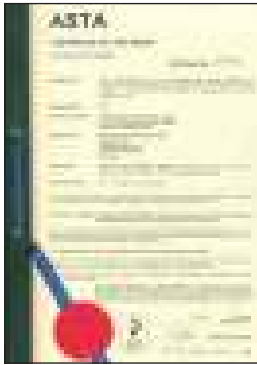

Suitable also for typical  
devices or the installation  
of armoured cables with  
earth connections

**Application:**  
**Motor Control Centre based  
on Mi System**

This Motor Control Centre installed in a big paper mill consists of 33 feeders ranging from 2.2 kW to 50 kW including complete wiring with main incomer of 630 A.

**Application:**  
Removable DIN rail rack for in-  
tegrated earth bounding in each  
Mi Circuit breaker box.

Cable entry for armoured  
cables via metal glands for  
earth connection according to  
British Standards.

**Key benefits**

<b>Material</b>	Thermoplastic material
<b>Corrosion-proof</b>	yes
<b>Degree of protection</b>	IP 65 (dust proof, water proof)
<b>Protection against mechanical impact</b>	no lasting deformations, elastic
<b>Weight</b>	"light"
<b>Subsequent handling (such as openings)</b>	"easy"
<b>Transparent lids</b>	standard offer
<b>Operating area</b>	partial opening range via lids of individual enclosures
<b>Adaptability to location</b>	by arrangement of modular enclosures
<b>Combinability / Expandability</b>	in all directions by combinable enclosures including electrical functions
<b>Availability in the market</b>	immediately with standard modules and accessories

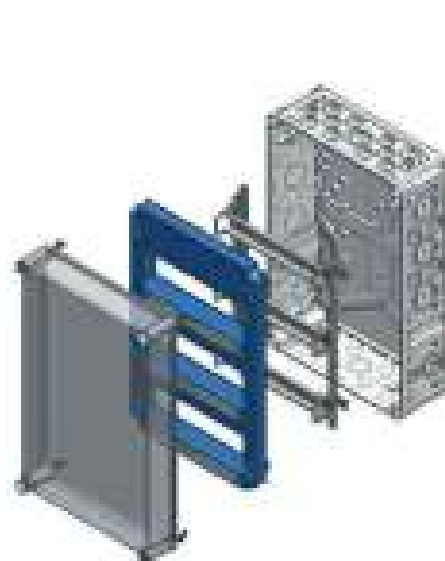

Integrated earth bounding in each circuit  
breaker box



Cable entry for armoured cables via metal glands

Combinable and extendable in all directions

Application examples



**Mi Distribution boards**

- modular enclosure system in grid of 150 mm
- 5 kapslingsstorlekar: 150 x 300 mm, 300 x 300 mm, 450 x 300 mm, 600 x 300 mm, 600 x 450 mm eller 600 x 600 mm
- for the assembly of power switchgear and controlgear assemblies (PSC) up to 630 A
- Enclosures can be used as well as single boxes.

The **modular design** in a basic grid of 150 mm allows free design of the outer form. The enclosures can be combined in all directions. Obstacle easily circumvented.

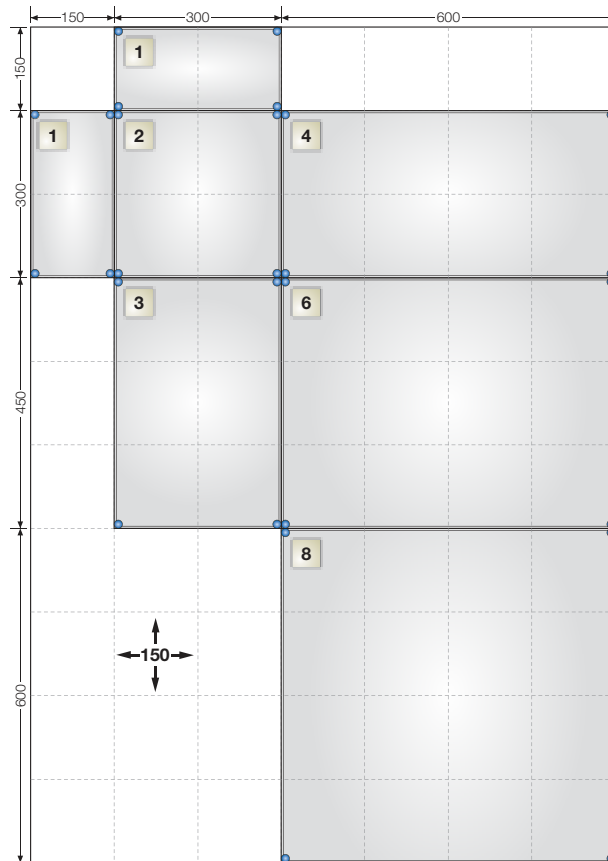

**Different enclosure depths**

allow the installation of equipment of different heights (Fig. 1).

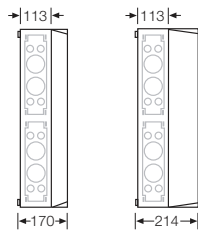

figure 1

With an extension frame the depth of the enclosure sizes 4 and 8 can be extended by 85 mm (Fig. 2).

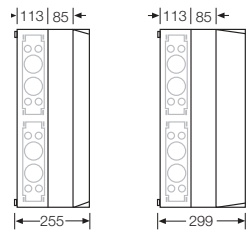
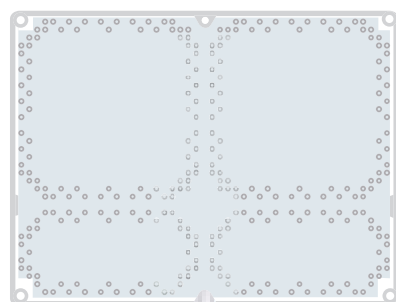

figure 2

**Enclosure size 6 (600x450 mm)**

Due to an enlarged terminal compartment directly in the housing, some electrical functions can be installed more economical.

An additional enclosure for wiring is not necessary.



**Combinable distribution boards with door**



Empty enclosures



Empty enclosures with hinged lid

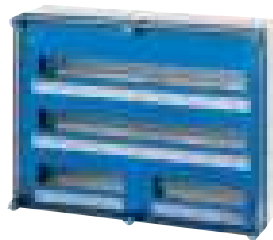

Circuit breaker box



Mi enclosures can be assembled to distribution boards.



Empty enclosures for the installation of electrical equipment via mounting plates or DIN rails

Example:  
Mi hinges for lids enable to operate installation device within a large area



Example:  
Locking option with triangle prevents unauthorized access



**Empty enclosures**  
transparent or opaque lids

**Empty enclosures**  
hinged transparent or opaque lids



**Mi 0100**  
built-in dimensions  
275x125x146 mm



**Mi 0101**  
built-in dimensions  
275x125x146 mm



**Mi 0200**  
built-in dimensions  
275x275x146 mm



**Mi 0201**  
built-in dimensions  
275x275x146 mm



**Mi 0210**  
built-in dimensions  
275x275x191 mm



**Mi 0211**  
built-in dimensions  
275x275x191 mm



**Mi 0220**  
built-in dimensions  
275x275x115 mm  
hinged lid



**Mi 0221**  
built-in dimensions  
275x275x115 mm  
hinged lid

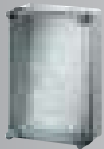

**Mi 0300**  
built-in dimensions  
275x425x146 mm



**Mi 0301**  
built-in dimensions  
275x425x146 mm



**Mi 0310**  
built-in dimensions  
275x425x191 mm



**Mi 0311**  
built-in dimensions  
275x425x191 mm



**Mi 0400**  
built-in dimensions  
275x575x146 mm



**Mi 0401**  
built-in dimensions  
275x575x146 mm



**Mi 0410**  
built-in dimensions  
275x575x191 mm



**Mi 0411**  
built-in dimensions  
275x575x191 mm



**Mi 0600**  
built-in dimensions  
575x425x146 mm



**Mi 0601**  
built-in dimensions  
575x425x146 mm



**Mi 0800**  
built-in dimensions  
575x575x146 mm



**Mi 0801**  
built-in dimensions  
575x575x146 mm



**Mi 9100**  
built-in dimensions  
122x272x146 mm,  
hinged lid



**Mi 9101**  
built-in dimensions  
122x272x146 mm,  
hinged lid



**Mi 9200**  
built-in dimensions  
275x275x146 mm,  
hinged lid



**Mi 9201**  
built-in dimensions  
275x275x146 mm,  
hinged lid



**Mi 9210**  
built-in dimensions  
275x275x191 mm,  
hinged lid



**Mi 9211**  
built-in dimensions  
275x275x191 mm,  
hinged lid



**Mi 9300**  
built-in dimensions  
275x425x146 mm,  
hinged lid



**Mi 9301**  
built-in dimensions  
275x425x146 mm,  
hinged lid



**Mi 9310**  
built-in dimensions  
275x425x191 mm,  
hinged lid



**Mi 9311**  
built-in dimensions  
275x425x191 mm,  
hinged lid



**Mi 9400**  
built-in dimensions  
275x575x146 mm,  
hinged lid



**Mi 9401**  
built-in dimensions  
275x575x146 mm,  
hinged lid



**Mi 9410**  
built-in dimensions  
275x575x191 mm,  
hinged lid



































**Mi 9411**  
built-in dimensions  
275x575x191 mm,  
hinged lid

Empty boxes for the installation of different electrical devices either directly over attachments in the base of the enclosures or on DIN rails or mounting plates.

Empty boxes with hinged lids applicable as single empty box for the installation of device via DIN rails or mounting plates. The lid keeps permanently connected to the box. Built-in devices can be easily operated and for example measurements conveniently carried out with both hands.

**Circuit breaker boxes**  
with or without PE/N

	<b>Mi 1109</b> 1x9x18 mm, PE+N		<b>Mi 1111</b> 1x12x18 mm, PE+N, 1 hinged lid
	<b>Mi 1112</b> 1x12x18 mm, PE+N		<b>Mi 1117</b> 1x12x18 mm, without PE+N, 1 hinged flap
	<b>Mi 1115</b> 1x12x18 mm without PE+N		<b>Mi 1222</b> 2x12x18 mm, PE+N, 2 hinged flaps
	<b>Mi 1224</b> 2x12x18 mm, PE+N		<b>Mi 1225</b> 2x12x18 mm without PE+N
	<b>Mi 1225</b> 2x12x18 mm without PE+N		<b>Mi 1220</b> 2x12x18 mm, PE+N, Scharnierdeckel
	<b>Mi 1220</b> 2x12x18 mm, PE+N, Scharnierdeckel		<b>Mi 1226</b> 2x12x18 mm without PE+N, hinged lid
	<b>Mi 1226</b> 2x12x18 mm without PE+N, hinged lid		<b>Mi 1336</b> 3x12x18 mm, PE+N
	<b>Mi 1336</b> 3x12x18 mm, PE+N		<b>Mi 1337</b> 3x12x18 mm, without PE+N, 3 hinged flaps
	<b>Mi 1335</b> 3x12x18 mm without PE+N		<b>Mi 1337</b> 3x12x18 mm, without PE+N, 3 hinged flaps
	<b>Mi 1448</b> 4x12x18 mm, PE+N		<b>Mi 1444</b> 4x12x18 mm, PE+N, 4 hinged flaps
	<b>Mi 1448</b> 4x12x18 mm, PE+N		<b>Mi 1445</b> 4x12x18 mm, without PE+N, 4 hinged flaps
	<b>Mi 1440</b> 3x12x18 mm, 1 DIN rail, without PE+N		<b>Mi 1443</b> 3x12x18 mm, 1 DIN rail, without PE+N, 3 hinged flaps
	<b>Mi 1440</b> 3x12x18 mm, 1 DIN rail, without PE+N		<b>Mi 1281</b> for miniature circuit breakers 1x6x18 mm, PEN
	<b>Mi 1456 *</b> 2x28x18 mm, PE+N		
	<b>Mi 1455 *</b> 2x28x18 mm without PE+N		
	<b>Mi 1684 *</b> 2x28x18 mm and 2x12x18 mm PE+N		
	<b>Mi 1683 *</b> 2x28x18 mm and 2x12x18 mm without PE+N		
	<b>Mi 1884 *</b> 3x28x18 mm, PE+N		
	<b>Mi 1885 *</b> 3x28x18 mm without PE+N		

**Circuit breaker boxes**  
removable DIN rail rack and  
earth connection

	<b>Mi 1118 *</b> 1x12x18 mm, without PE+N		<b>Mi 1119 *</b> 1x12x18 mm, without PE+N, 1 hinged flap
	<b>Mi 1228 *</b> 2x12x18 mm, without PE+N		<b>Mi 1229 *</b> 2x12x18 mm, without PE+N, 2 hinged flaps
	<b>Mi 1221 *</b> 2x12x18 mm, without PE+N with hinged lid		<b>Mi 1339 *</b> 3x12x18 mm, without PE+N, 3 hinged flaps
	<b>Mi 1338 *</b> 3x12x18 mm, without PE+N		<b>Mi 1449 *</b> 4x12x18 mm, without PE+N, 4 hinged flaps
	<b>Mi 1446 *</b> 3x12x18 mm, without PE+N		
	<b>Mi 1446 *</b> 3x12x18 mm, without PE+N		
	<b>Mi 1446 *</b> 3x12x18 mm, without PE+N		
	<b>Mi 1446 *</b> 3x12x18 mm, without PE+N		
	<b>Mi 1455 *</b> 2x28x18 mm, without PE+N		
	<b>Mi 1455 *</b> 2x28x18 mm, without PE+N		
	<b>Mi 1686 *</b> 2x28x18 mm and 2x12x18 mm		
	<b>Mi 1686 *</b> 2x28x18 mm and 2x12x18 mm		
	<b>Mi 1885 *</b> 3x28x18 mm, without PE+N		
	<b>Mi 1885 *</b> 3x28x18 mm, without PE+N		



\* With removable DIN rail rack or earth connection

Circuit breaker boxes for the installation of DIN rail equipment in accordance with DIN 43880 from 9 to 84 modules.  
Unused DIN rail openings in covers are stripped with attached blanking strips.



## Mi Distribution Boards

### Empty boxes

for the assembly of power distribution boards (PSC) up to 630 A  
in accordance with IEC 61430-2

- Transparent or opaque enclosure lids
- Empty enclosure with hinged lid, trilaterally combinable
- Device installation either on mounting plates or DIN rails
- Installation depths extendable by using lids of different heights or extension frames
- Enclosures can also be used as single boxes
- Protection class II, 
- Degree of protection: IP 65
- Material: PC (polycarbonate)
- Colour: grey, RAL 7035



**Mi 0100**

**Built-in dimensions W 275 x H 125 x D 150 mm**

- max. installation depth with built-in mounting plate 146 mm, with built-in DIN rail 135 mm
- box size 1
- please order DIN rails, mounting plates or covers additionally
- with transparent lid
- lid fasteners for tool operation

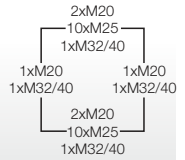
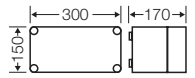

**Mi 0200**

**Built-in dimensions W 275 x H 275 x D 150 mm**

- max. installation depth with built-in mounting plate 146 mm, with built-in DIN rail 135 mm
- box size 2
- please order DIN rails, mounting plates or covers additionally
- with transparent lid
- lid fasteners for tool operation

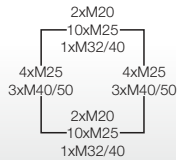
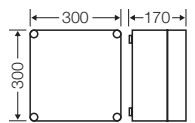

**Mi 0210**

**Built-in dimensions W 275 x H 275 x D 195 mm**

- max. installation depth with built-in mounting plate 191 mm, with built-in DIN rail 180 mm
- box size 2
- please order DIN rails, mounting plates or covers additionally
- with transparent lid
- lid fasteners for tool operation

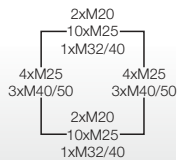
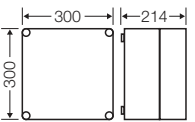

Please note:

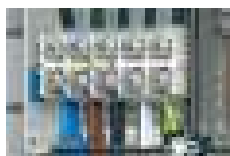

Terminals for incoming/outgoing cables under accessories

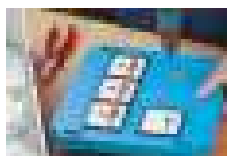

Covers for protection of installation device, see accessories



**Mi 0220**

**Built-in dimensions W 275 x H 275 x D 119 mm**

- max. installation depth with built-in mounting plate 115 mm, with built-in DIN rail 104 mm
- box size 2
- please order DIN rails, mounting plates or covers additionally
- with hinged lid for built-in equipment with protection cover which must be operated
- with transparent lid
- lid fasteners for tool operation

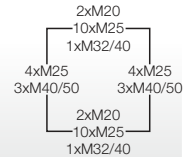
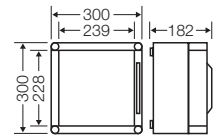

**Mi 0300**

**Built-in dimensions W 275 x H 425 x D 150 mm**

- max. installation depth with built-in mounting plate 146 mm, with built-in DIN rail 135 mm
- box size 3
- please order DIN rails, mounting plates or covers additionally
- with transparent lid
- lid fasteners for tool operation

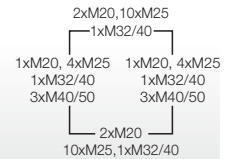
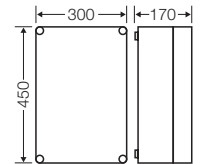

**Mi 0310**

**Built-in dimensions W 275 x H 425 x D 195 mm**

- max. installation depth with built-in mounting plate 191 mm, with built-in DIN rail 180 mm
- box size 3
- please order DIN rails, mounting plates or covers additionally
- with transparent lid
- lid fasteners for tool operation

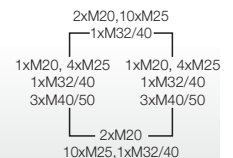
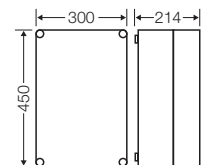

**Mi 0400**

**Built-in dimensions W 275 x H 575 x D 150 mm**

- max. installation depth with built-in mounting plate 146 mm, with built-in DIN rail 135 mm
- box size 4
- please order DIN rails, mounting plates or covers additionally
- with transparent lid
- lid fasteners for tool operation

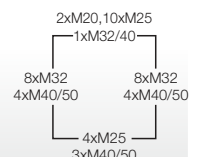
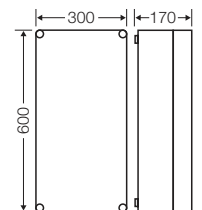

**Mi Distribution Boards**  
Empty boxes with transparent lid



**Mi 0410**

**Built-in dimensions W 275 x H 575 x D 195 mm**

- max. installation depth with built-in mounting plate 191 mm, with built-in DIN rail 180 mm
- box size 4
- please order DIN rails, mounting plates or covers additionally
- with transparent lid
- lid fasteners for tool operation

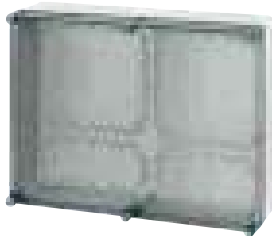
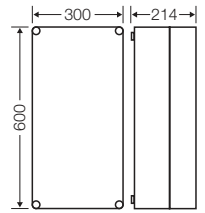

**Mi 0600**

**built-in dimensions W 575 x H 425 x D 150 mm**

- max. installation depth with built-in mounting plate 146 mm, with built-in DIN rail 135 mm
- box size 6
- please order DIN rails, mounting plates or covers additionally
- with transparent lid
- lid fasteners for tool operation

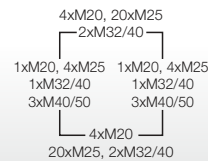
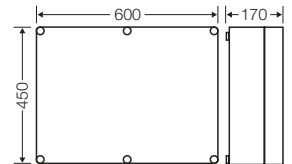

**Mi 0800**

**Built-in dimensions W 575 x H 575 x D 150 mm**

- max. installation depth with built-in mounting plate 146 mm, with built-in DIN rail 135 mm
- box size 8
- please order DIN rails, mounting plates or covers additionally
- cable entry only possible via flange
- with transparent lid
- lid fasteners for tool operation

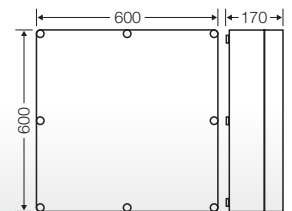

Please note:

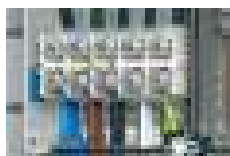

Terminals for incoming/outgoing cables under accessories

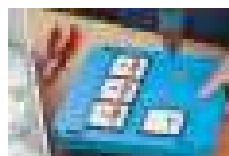

Covers for protection of installation device, see accessories



**Mi 0101**

**Built-in dimensions W 275 x H 125 x D 150 mm**

- max. installation depth with built-in mounting plate 146 mm, with built-in DIN rail 135 mm
- box size 1
- please order DIN rails, mounting plates or covers additionally
- with opaque lid
- lid fasteners for tool operation

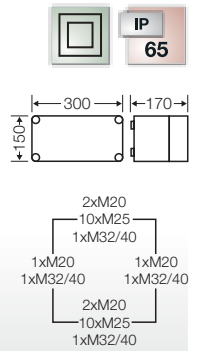

**Mi 0201**

**Built-in dimensions W 275 x H 275 x D 150 mm**

- max. installation depth with built-in mounting plate 146 mm, with built-in DIN rail 135 mm
- box size 2
- please order DIN rails, mounting plates or covers additionally
- with opaque lid
- lid fasteners for tool operation

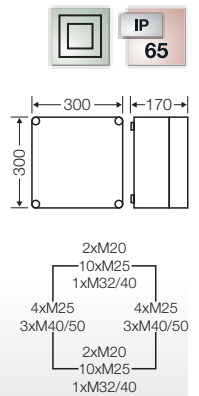

**Mi 0211**

**Built-in dimensions W 275 x H 275 x D 195 mm**

- max. installation depth with built-in mounting plate 191 mm, with built-in DIN rail 180 mm
- box size 2
- please order DIN rails, mounting plates or covers additionally
- with opaque lid
- lid fasteners for tool operation

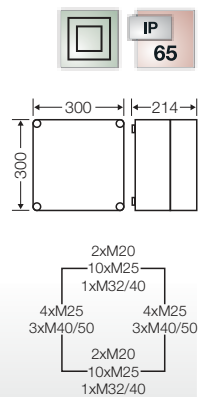

**Mi 0221**

**Built-in dimensions W 275 x H 275 x D 119 mm**

- max. installation depth with built-in mounting plate 115 mm, with built-in DIN rail 104 mm
- box size 2
- please order DIN rails, mounting plates or covers additionally
- with hinged lid for built-in equipment with protection cover which must be operated
- with opaque lid
- lid fasteners for tool operation

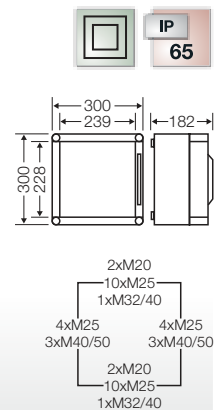



**Mi 0301**

**Built-in dimensions W 275 x H 425 x D 150 mm**

- max. installation depth with built-in mounting plate 146 mm, with built-in DIN rail 135 mm
- box size 3
- please order DIN rails, mounting plates or covers additionally
- with opaque lid
- lid fasteners for tool operation

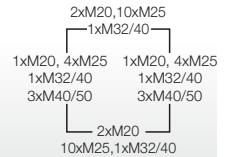
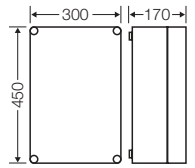

**Mi 0311**

**Built-in dimensions W 275 x H 425 x D 195 mm**

- max. installation depth with built-in mounting plate 191 mm, with built-in DIN rail 180 mm
- box size 3
- please order DIN rails, mounting plates or covers additionally
- with opaque lid
- lid fasteners for tool operation

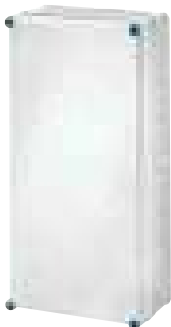
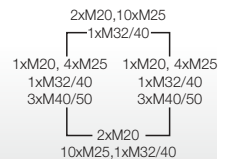
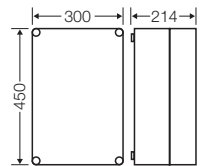

**Mi 0401**

**Built-in dimensions W 275 x H 575 x D 150 mm**

- max. installation depth with built-in mounting plate 146 mm, with built-in DIN rail 135 mm
- box size 4
- please order DIN rails, mounting plates or covers additionally
- with opaque lid
- lid fasteners for tool operation

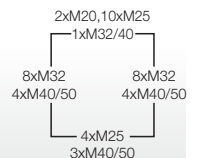
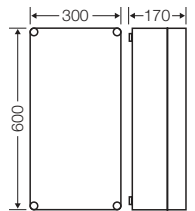

Please note:

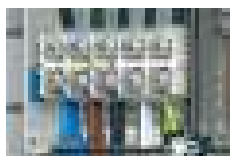

Terminals for incoming/outgoing cables under accessories

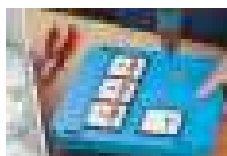

Covers for protection of installation device, see accessories

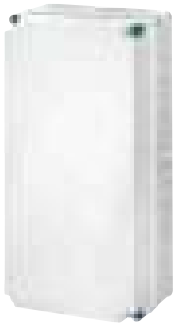

**Mi 0411**

**Built-in dimensions W 275 x H 575 x D 195 mm**

- max. installation depth with built-in mounting plate 191 mm, with built-in DIN rail 180 mm
- box size 4
- please order DIN rails, mounting plates or covers additionally
- with opaque lid
- lid fasteners for tool operation

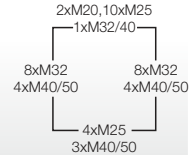
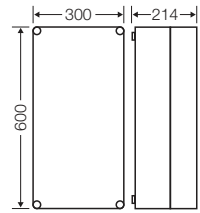

**Mi 0601**

**built-in dimensions W 575 x H 425 x D 150 mm**

- max. installation depth with built-in mounting plate 146 mm, with built-in DIN rail 135 mm
- box size 6
- please order DIN rails, mounting plates or covers additionally
- with opaque lid
- lid fasteners for tool operation

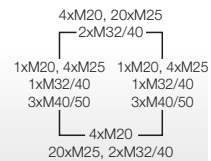
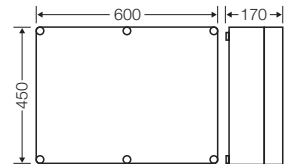

**Mi 0801**

**Built-in dimensions W 575 x H 575 x D 150 mm**

- max. installation depth with built-in mounting plate 146 mm, with built-in DIN rail 135 mm
- box size 8
- please order DIN rails, mounting plates or covers additionally
- cable entry only possible via flange
- with opaque lid
- lid fasteners for tool operation

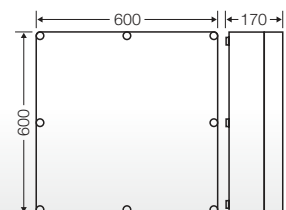

**Mi Distribution Boards**  
**Empty boxes**  
**with hinged, transparent lid**



**Mi 9100**

**Built-in dimensions W 125 x H 275 x D 150 mm**

- max. installation depth with built-in mounting plate 146 mm, with built-in DIN rail 135 mm
- box size 1
- please order DIN rails, mounting plates or covers additionally
- 3 walls with metric knockouts for cable entry and assembly
- trilaterally combinable
- lid hinges attached
- with transparent, hinged lid
- lid fasteners for tool operation

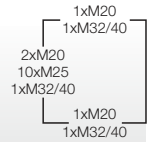
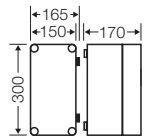

**Mi 9200**

**Built-in dimensions W 275 x H 275 x D 150 mm**

- max. installation depth with built-in mounting plate 146 mm, with built-in DIN rail 135 mm
- box size 2
- please order DIN rails, mounting plates or covers additionally
- trilaterally combinable
- 3 walls with metric knockouts for cable entry and assembly
- lid hinges attached
- with transparent, hinged lid
- lid fasteners for tool operation

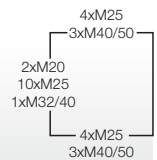
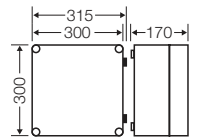

**Mi 9210**

**Built-in dimensions W 275 x H 275 x D 195 mm**

- max. installation depth with built-in mounting plate 191 mm, with built-in DIN rail 180 mm
- box size 2
- please order DIN rails, mounting plates or covers additionally
- trilaterally combinable
- 3 walls with metric knockouts for cable entry and assembly
- lid hinges attached
- with transparent, hinged lid
- lid fasteners for tool operation

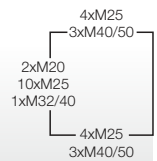
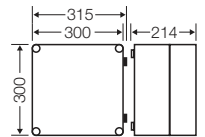

Please note:

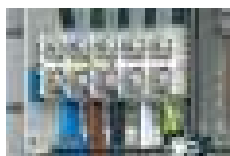

Terminals for incoming/outgoing cables under accessories

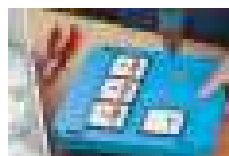

Covers for protection of installation device, see accessories

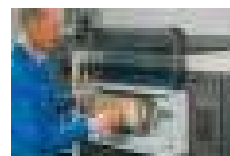

Empty enclosures with hinged lids

**Mi Distribution Boards**  
**Empty boxes**  
**with hinged, transparent lid**



**Mi 9300**

**Built-in dimensions W 275 x H 425 x D 150 mm**

- max. installation depth with built-in mounting plate 146 mm, with built-in DIN rail 135 mm
- box size 3
- please order DIN rails, mounting plates or covers additionally
- trilaterally combinable
- 3 walls with metric knockouts for cable entry and assembly
- lid hinges attached
- with transparent, hinged lid
- lid fasteners for tool operation

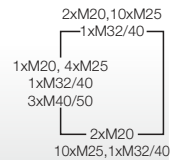
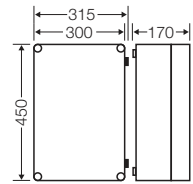

**Mi 9310**

**Built-in dimensions W 275 x H 425 x D 195 mm**

- max. installation depth with built-in mounting plate 191 mm, with built-in DIN rail 180 mm
- box size 3
- please order DIN rails, mounting plates or covers additionally
- trilaterally combinable
- 3 walls with metric knockouts for cable entry and assembly
- lid hinges attached
- with transparent, hinged lid
- lid fasteners for tool operation

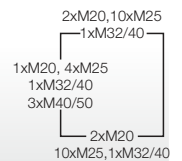
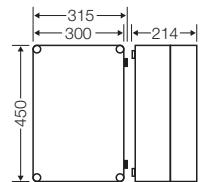

**Mi 9400**

**Built-in dimensions W 275 x H 575 x D 150 mm**

- max. installation depth with built-in mounting plate 146 mm, with built-in DIN rail 135 mm
- box size 4
- please order DIN rails, mounting plates or covers additionally
- trilaterally combinable
- 3 walls with metric knockouts for cable entry and assembly
- lid hinges attached
- with transparent, hinged lid
- lid fasteners for tool operation

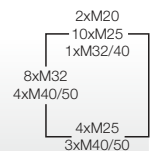
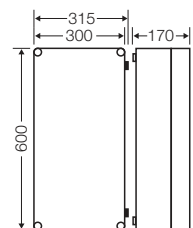

**Mi Distribution Boards**  
**Empty boxes**  
**with hinged, transparent lid**



**Mi 9410**

**Built-in dimensions W 275 x H 575 x D 195 mm**

- max. installation depth with built-in mounting plate 191 mm, with built-in DIN rail 180 mm
- box size 4
- please order DIN rails, mounting plates or covers additionally
- trilaterally combinable
- 3 walls with metric knockouts for cable entry and assembly
- lid hinges attached
- with transparent, hinged lid
- lid fasteners for tool operation

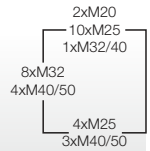
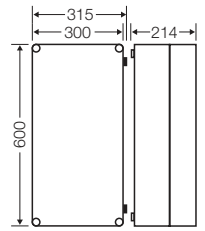

Please note:

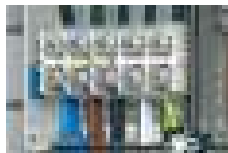

Terminals for incoming/outgoing cables under accessories

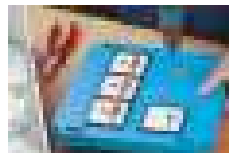

Covers for protection of installation device, see accessories

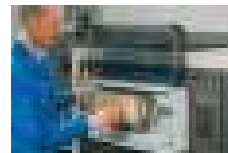

Empty enclosures with hinged lids

**Mi Distribution Boards**  
**Empty boxes**  
**with hinged, opaque lid**



**Mi 9101**

**Built-in dimensions W 125 x H 275 x D 150 mm**

- max. installation depth with built-in mounting plate 146 mm, with built-in DIN rail 135 mm
- box size 1
- please order DIN rails, mounting plates or covers additionally
- trilaterally combinable
- 3 walls with metric knockouts for cable entry and assembly
- lid hinges attached
- with opaque, hinged lid
- lid fasteners for tool operation

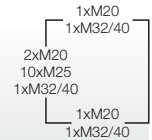
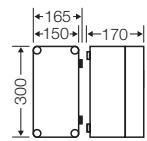

**Mi 9201**

**Built-in dimensions W 275 x H 275 x D 150 mm**

- max. installation depth with built-in mounting plate 146 mm, with built-in DIN rail 135 mm
- box size 2
- please order DIN rails, mounting plates or covers additionally
- trilaterally combinable
- 3 walls with metric knockouts for cable entry and assembly
- lid hinges attached
- with opaque, hinged lid
- lid fasteners for tool operation

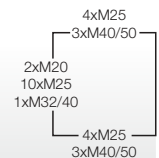
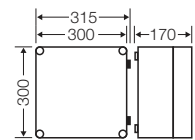

**Mi 9211**

**Built-in dimensions W 275 x H 275 x D 195 mm**

- max. installation depth with built-in mounting plate 191 mm, with built-in DIN rail 180 mm
- box size 2
- please order DIN rails, mounting plates or covers additionally
- trilaterally combinable
- 3 walls with metric knockouts for cable entry and assembly
- lid hinges attached
- with opaque, hinged lid
- lid fasteners for tool operation

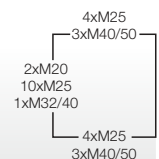
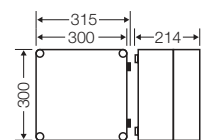

**Mi 9301**

**Built-in dimensions W 275 x H 425 x D 150 mm**

- max. installation depth with built-in mounting plate 146 mm, with built-in DIN rail 135 mm
- box size 3
- please order DIN rails, mounting plates or covers additionally
- trilaterally combinable
- 3 walls with metric knockouts for cable entry and assembly
- lid hinges attached
- with opaque, hinged lid
- lid fasteners for tool operation

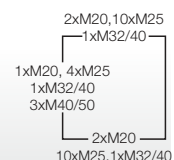
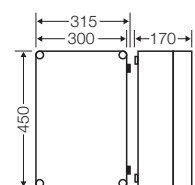

**Mi Distribution Boards**  
**Empty boxes**  
**with hinged, opaque lid**



**Mi 9311**

**Built-in dimensions W 275 x H 425 x D 195 mm**

- max. installation depth with built-in mounting plate 191 mm, with built-in DIN rail 180 mm
- box size 3
- please order DIN rails, mounting plates or covers additionally
- trilaterally combinable
- 3 walls with metric knockouts for cable entry and assembly
- lid hinges attached
- with opaque, hinged lid
- lid fasteners for tool operation

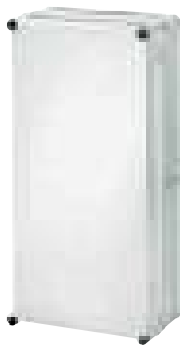
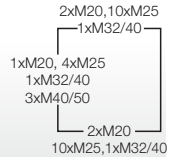
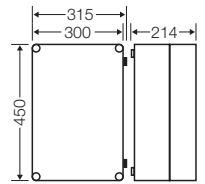

**Mi 9401**

**Built-in dimensions W 275 x H 575 x D 150 mm**

- max. installation depth with built-in mounting plate 146 mm, with built-in DIN rail 135 mm
- box size 4
- please order DIN rails, mounting plates or covers additionally
- trilaterally combinable
- 3 walls with metric knockouts for cable entry and assembly
- lid hinges attached
- with opaque, hinged lid
- lid fasteners for tool operation

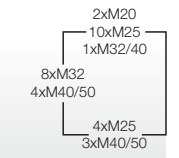
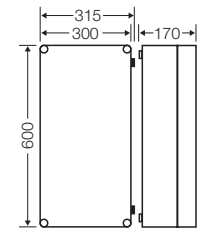

**Mi 9411**

**Built-in dimensions W 275 x H 575 x D 195 mm**

- max. installation depth with built-in mounting plate 191 mm, with built-in DIN rail 180 mm
- box size 4
- please order DIN rails, mounting plates or covers additionally
- trilaterally combinable
- 3 walls with metric knockouts for cable entry and assembly
- lid hinges attached
- with opaque, hinged lid
- lid fasteners for tool operation

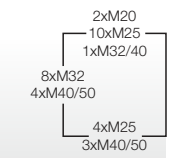
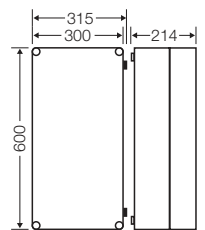

Please note:

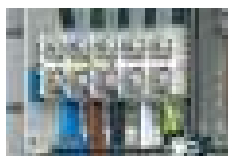

Terminals for incoming/  
outgoing cables under  
accessories

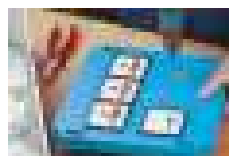

Covers for protection of  
installation device, see  
accessories

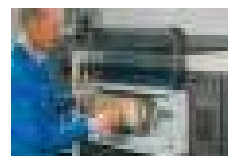

Empty enclosures with  
hinged lids

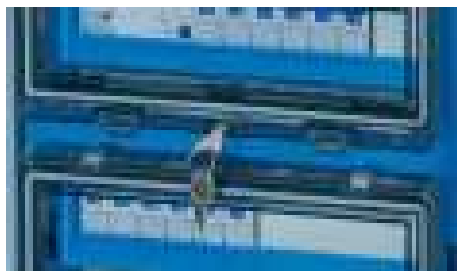
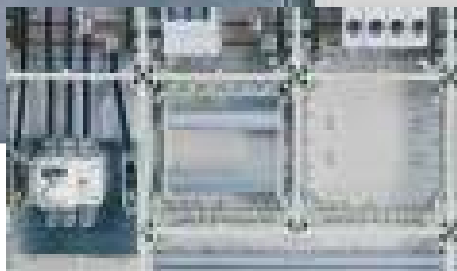
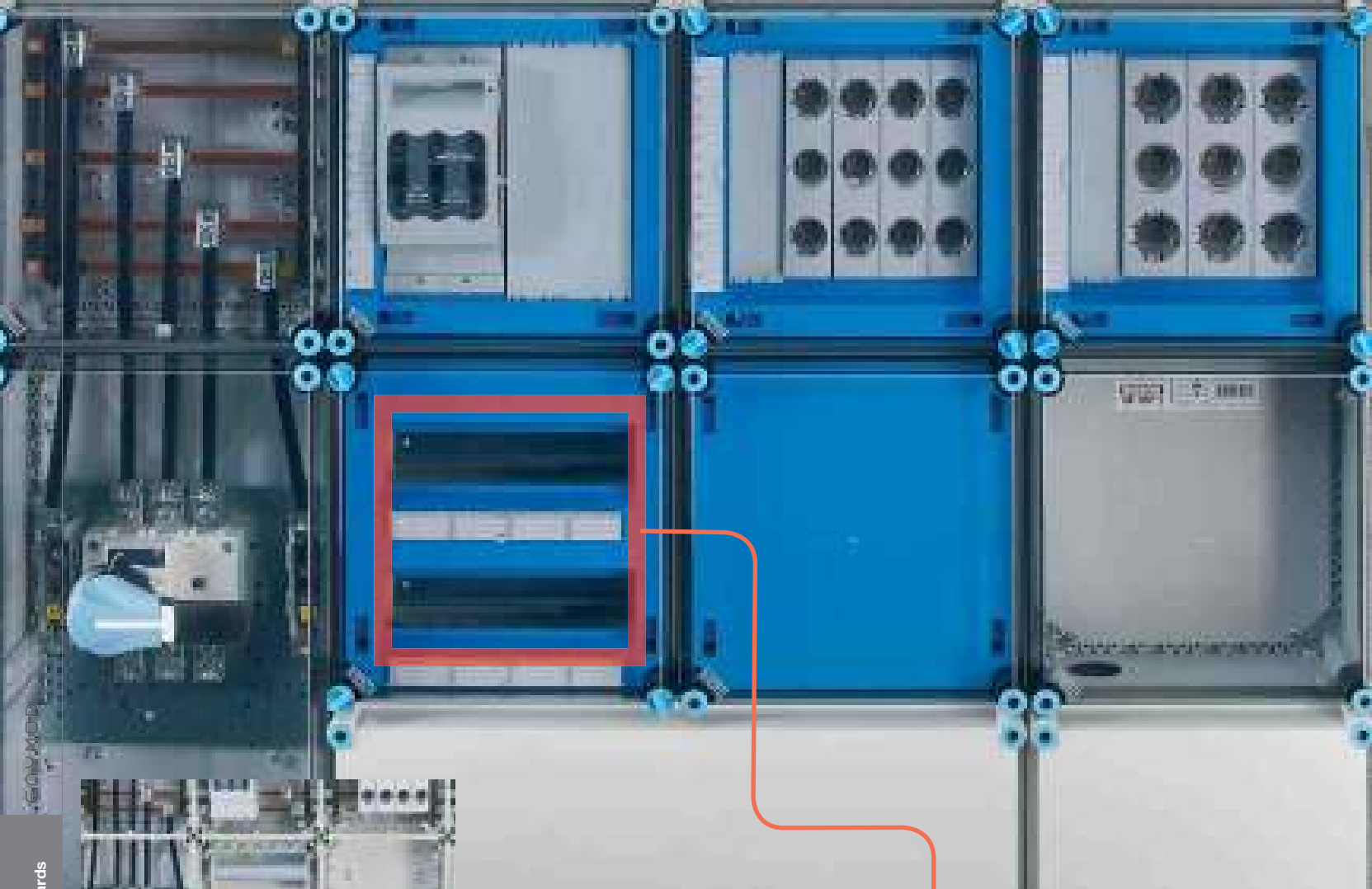

### Mi Distribution Boards

**Circuit breaker boxes with or without PE and N terminals with hinged flaps**

**for the assembly of power distribution boards (PSC) up to 630 A in accordance with IEC 61430-2**

- Transparent lids
- Hinged flap or hinged lid for an easy operation of installation devices
- Hinged flap lock against unauthorised opening under accessories
- Circuit breaker boxes with or without PE and N terminals
- Protection against direct contact with hazardous live parts for operable installation devices
- Included blanking strips for unused DIN rail openings
- Attached labelling strips for circuit identification
- Enclosures can also be used as single boxes
- Protection class II, 
- Degree of protection: IP 65
- Material: PC (polycarbonate)
- Colour: grey, RAL 7035

**Mi Distribution Boards**  
Circuit breaker box with PE and N terminals



**Mi 1109**  
**9 modules: 1 x 9 x 18 mm**

- 1-row
- FIXCONNECT® plug-in terminal technology for PE and N
- PE/N 2 x 25 mm<sup>2</sup>, 8 x 4 mm<sup>2</sup>, Cu each
- for installation of DIN rail equipment in accordance with DIN 43880
- with blanking strips for unused DIN rail openings
- lid fasteners for hand operation

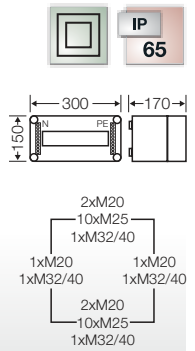

**Mi 1112**  
**12 modules: 1 x 12 x 18 mm**

- 1-row
- with screw-type terminals for PE/N, for copper conductors
- per PE/N 10 x 16 mm<sup>2</sup>, Cu
- for installation of DIN rail equipment in accordance with DIN 43880
- with blanking strips for unused DIN rail openings
- lid fasteners for hand operation

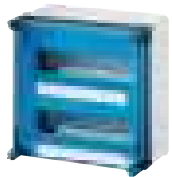
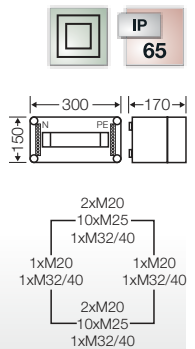

**Mi 1224**  
**24 modules: 2 x 12 x 18 mm**

- 2-row
- FIXCONNECT® plug-in terminal technology for PE and N
- per PE/N 3 x 25 mm<sup>2</sup>, 12 x 4 mm<sup>2</sup>, Cu
- N separable for various potentials
- for installation of DIN rail equipment in accordance with DIN 43880
- with blanking strips for unused DIN rail openings
- lid fasteners for hand operation

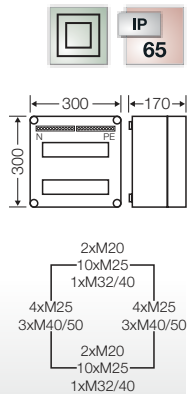

Please note:



Connection box for plug devices, push buttons or switches under accessories

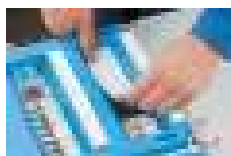

Cover cutouts against direct contact with hazardous live parts



Editable labelling strips: [www.hensel-electric.de](http://www.hensel-electric.de)

**Mi Distribution Boards**  
Circuit breaker box with PE and N terminals

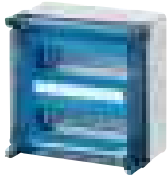

**Mi 1220**

**24 modules: 2 x 12 x 18 mm**

- 2-row
- with hinged lid
- FIXCONNECT® plug-in terminal technology for PE and N
- per PE/N 3 x 25 mm<sup>2</sup>, 12 x 4 mm<sup>2</sup>, Cu
- N separable for various potentials
- for installation of DIN rail equipment in accordance with DIN 43880
- with blanking strips for unused DIN rail openings
- lid fasteners for hand operation

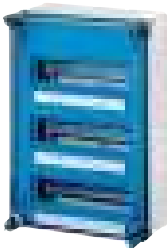
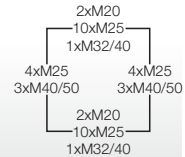
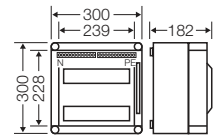

**Mi 1336**

**36 modules: 3 x 12 x 18 mm**

- 3-row
- FIXCONNECT® plug-in terminal technology for PE and N
- per PE/N 6 x 25 mm<sup>2</sup>, 24 x 4 mm<sup>2</sup>, Cu
- N separable for various potentials
- for installation of DIN rail equipment in accordance with DIN 43880
- with blanking strips for unused DIN rail openings
- lid fasteners for hand operation

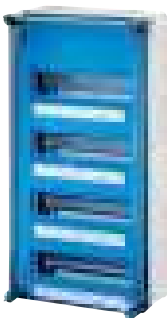
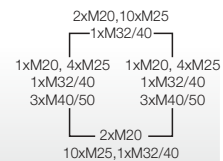
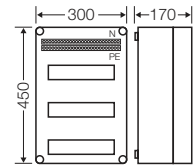

**Mi 1448**

**48 modules: 4 x 12 x 18 mm**

- 4-row
- FIXCONNECT® plug-in terminal technology for PE and N
- per PE/N 6 x 25 mm<sup>2</sup>, 24 x 4 mm<sup>2</sup>, Cu
- N separable for various potentials
- for installation of DIN rail equipment in accordance with DIN 43880
- with blanking strips for unused DIN rail openings
- lid fasteners for hand operation

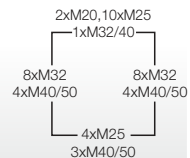
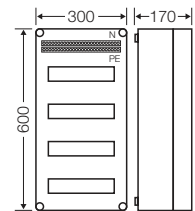

**Mi 1456**

**56 modules: 2 x 28 x 18 mm**

- 2-row
- FIXCONNECT® plug-in terminal technology for PE and N
- per PE/N 6 x 25 mm<sup>2</sup>, 24 x 4 mm<sup>2</sup>, Cu
- N separable for various potentials
- for installation of DIN rail equipment in accordance with DIN 43880
- with blanking strips for unused DIN rail openings
- lid fasteners for hand operation
- with removable DIN rail rack and earth connection
- DIN rail rack can be earthed

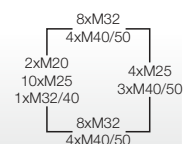
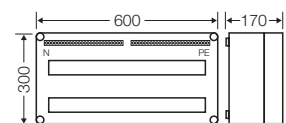

**Mi Distribution Boards**  
Circuit breaker box with PE and N terminals



**Mi 1684**

**80 modules: 2 x 28 x 18 mm and 2 x 12 x 18 mm**

- 3-row
- FIXCONNECT® plug-in terminal technology for PE and N
- per PE/N 6 x 25 mm<sup>2</sup>, 24 x 4 mm<sup>2</sup>, Cu
- N separable for various potentials
- for installation of DIN rail equipment in accordance with DIN 43880
- with blanking strips for unused DIN rail openings
- lid fasteners for hand operation
- with removable DIN rail rack and earth connection
- DIN rail rack can be earthed

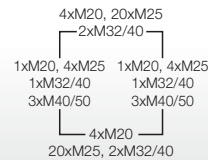
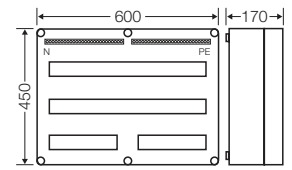

**Mi 1884**

**84 modules: 3 x 28 x 18 mm**

- 3-row
- FIXCONNECT® plug-in terminal technology for PE and N
- per PE/N 6 x 25 mm<sup>2</sup>, 24 x 4 mm<sup>2</sup>, Cu
- N separable for various potentials
- for installation of DIN rail equipment in accordance with DIN 43880
- with blanking strips for unused DIN rail openings
- lid fasteners for hand operation
- with removable DIN rail rack and earth connection
- DIN rail rack can be earthed
- cable entry only possible via flange

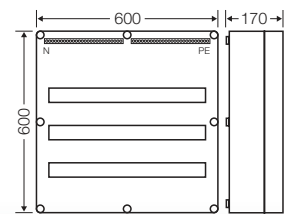

Please note:

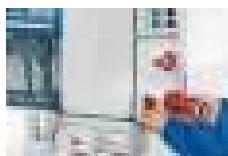

Connection box for plug devices, push buttons or switches under accessories

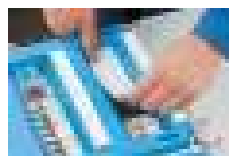

Cover cutouts against direct contact with hazardous live parts

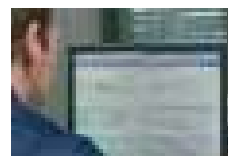

Editable labelling strips: [www.hensel-electric.de](http://www.hensel-electric.de)



**Mi 1111**

**12 modules: 1 x 12 x 18 mm**

- 1-row
- with 1 hinged flap
- hinged flap lockable with accessories
- with screw-type terminals for PE/N, for copper conductors
- per PE/N 10 x 16 mm<sup>2</sup>, Cu
- for installation of DIN rail equipment in accordance with DIN 43880
- with blanking strips for unused DIN rail openings
- lid fasteners for hand operation

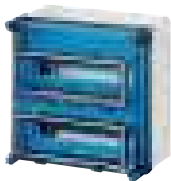
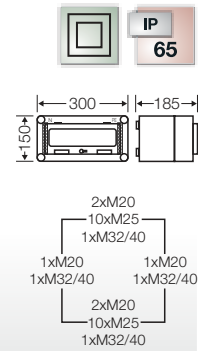

**Mi 1222**

**24 modules: 2 x 12 x 18 mm**

- 2-row
- with 2 hinged flaps
- hinged flap lockable with accessories
- FIXCONNECT® plug-in terminal technology for PE and N
- per PE/N 3 x 25 mm<sup>2</sup>, 12 x 4 mm<sup>2</sup>, Cu
- N separable for various potentials
- for installation of DIN rail equipment in accordance with DIN 43880
- with blanking strips for unused DIN rail openings
- lid fasteners for hand operation

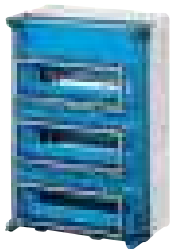
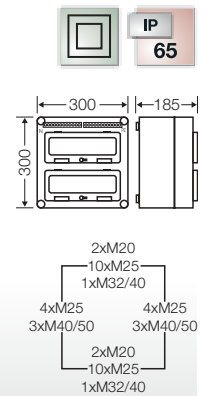

**Mi 1333**

**36 modules: 3 x 12 x 18 mm**

- 3-row
- with 3 hinged flaps
- hinged flap lockable with accessories
- FIXCONNECT® plug-in terminal technology for PE and N
- per PE/N 6 x 25 mm<sup>2</sup>, 24 x 4 mm<sup>2</sup>, Cu
- N separable for various potentials
- for installation of DIN rail equipment in accordance with DIN 43880
- with blanking strips for unused DIN rail openings
- lid fasteners for hand operation

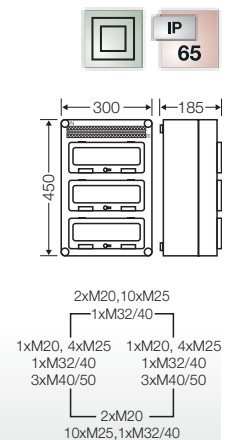

**Mi 1444**

**48 modules: 4 x 12 x 18 mm**

- 4-row
- with 4 hinged flaps
- hinged flap lockable with accessories
- FIXCONNECT® plug-in terminal technology for PE and N
- per PE/N 6 x 25 mm<sup>2</sup>, 24 x 4 mm<sup>2</sup>, Cu
- N separable for various potentials
- for installation of DIN rail equipment in accordance with DIN 43880
- with blanking strips for unused DIN rail openings
- lid fasteners for hand operation

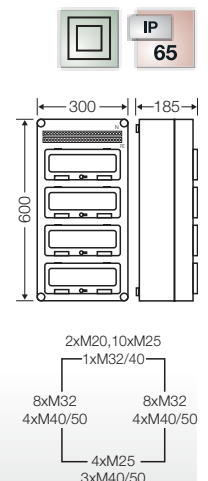



**Mi 1115**

**12 modules: 1 x 12 x 18 mm**  
**without PE and N terminal**

- 1-row
- for installation of DIN rail equipment in accordance with DIN 43880
- order PE/N terminals separately
- with blanking strips for unused DIN rail openings
- lid fasteners for hand operation

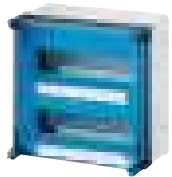
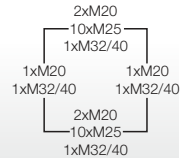
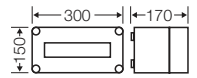

**Mi 1225**

**24 modules: 2 x 12 x 18 mm**  
**without PE and N terminal**

- 2-row
- for installation of DIN rail equipment in accordance with DIN 43880
- order PE/N terminals separately
- with blanking strips for unused DIN rail openings
- lid fasteners for hand operation

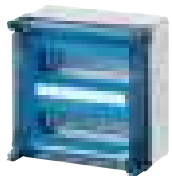
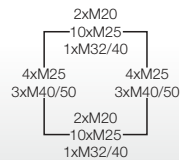
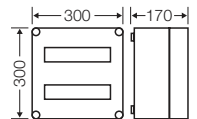

**Mi 1226**

**24 modules: 2 x 12 x 18 mm**  
**without PE and N terminal**  
**with hinged lid**

- 2-row
- for installation of DIN rail equipment in accordance with DIN 43880
- order PE/N terminals separately
- with blanking strips for unused DIN rail openings
- lid fasteners for hand operation

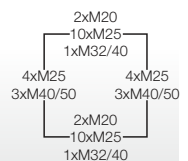
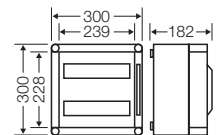

Please note:



Connection box for plug devices, push buttons or switches under accessories

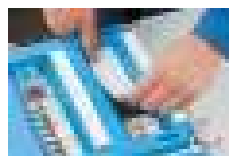

Cover cutouts against direct contact with hazardous live parts

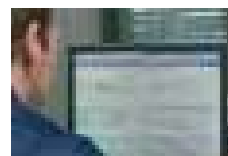

Editable labelling strips:  
[www.hensel-electric.de](http://www.hensel-electric.de)

**Mi Distribution Boards**  
Circuit breaker box without PE and N terminals

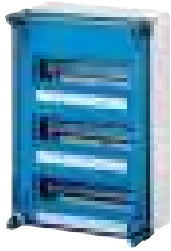

**Mi 1335**  
**36 modules: 3 x 12 x 18 mm**  
**without PE and N terminal**

- 3-row
- for installation of DIN rail equipment in accordance with DIN 43880
- order PE/N terminals separately
- with blanking strips for unused DIN rail openings
- lid fasteners for hand operation

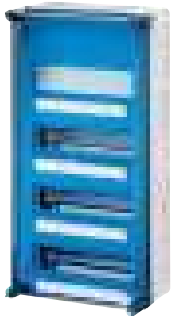
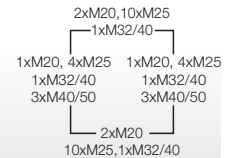
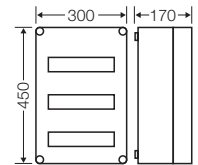

**Mi 1440**  
**36 modules: 3 x 12 x 18 mm**  
**without PE and N terminal**  
**with additional DIN rail**

- 4-row
- with 1 DIN rail 216 mm wide (for installation depth of 72 mm)
- for installation of DIN rail equipment in accordance with DIN 43880
- order PE/N terminals separately
- with blanking strips for unused DIN rail openings
- lid fasteners for hand operation

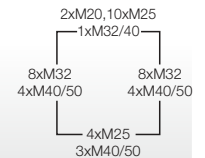
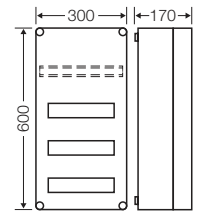

**Mi 1455**  
**56 modules: 2 x 28 x 18 mm**  
**without PE and N terminal**

- 2-row
- for installation of DIN rail equipment in accordance with DIN 43880
- order PE/N terminals separately
- with blanking strips for unused DIN rail openings
- lid fasteners for hand operation
- with removable DIN rail rack and earth connection

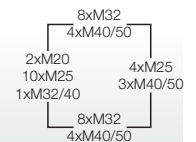
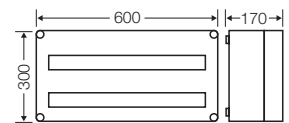

**Mi Distribution Boards**  
Circuit breaker box without PE and N terminals



**Mi 1683**

**80 modules: 2 x 28 x 18 mm and 2 x 12 x 18 mm without PE and N terminal**

- 3-row
- for installation of DIN rail equipment in accordance with DIN 43880
- order PE/N terminals separately
- with blanking strips for unused DIN rail openings
- lid fasteners for hand operation
- with removable DIN rail rack and earth connection

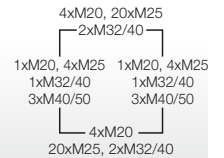
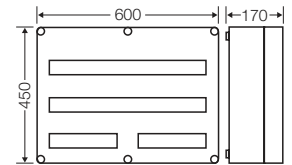

**Mi 1885**

**84 modules: 3 x 28 x 18 mm without PE and N terminal**

- 3-row
- for installation of DIN rail equipment in accordance with DIN 43880
- order PE/N terminals separately
- with blanking strips for unused DIN rail openings
- lid fasteners for hand operation
- with removable DIN rail rack and earth connection
- cable entry only possible via flange

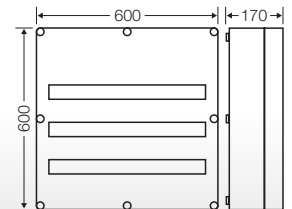

Please note:



Connection box for plug devices, push buttons or switches under accessories

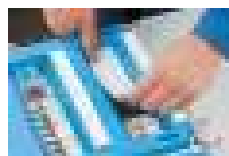

Cover cutouts against direct contact with hazardous live parts



Editable labelling strips: [www.hensel-electric.de](http://www.hensel-electric.de)

**Mi Distribution Boards**

**Circuit breaker boxes without PE and N terminals with hinged flaps**



**Mi 1117**

**12 modules: 1 x 12 x 18 mm without PE and N terminal**

- 1-row
- with 1 hinged flap
- hinged flap lockable with accessories
- for installation of DIN rail equipment in accordance with DIN 43880
- order PE/N terminals separately
- with blanking strips for unused DIN rail openings
- lid fasteners for hand operation

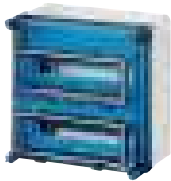
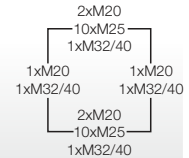
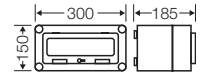

**Mi 1227**

**24 modules: 2 x 12 x 18 mm without PE and N terminal**

- 2-row
- with 2 hinged flaps
- hinged flap lockable with accessories
- for installation of DIN rail equipment in accordance with DIN 43880
- order PE/N terminals separately
- with blanking strips for unused DIN rail openings
- lid fasteners for hand operation

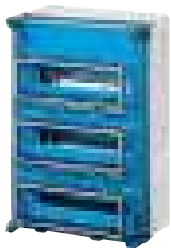
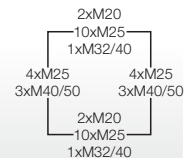
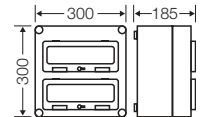

**Mi 1337**

**36 modules: 3 x 12 x 18 mm without PE and N terminal**

- 3-row
- with 3 hinged flaps
- hinged flap lockable with accessories
- for installation of DIN rail equipment in accordance with DIN 43880
- order PE/N terminals separately
- with blanking strips for unused DIN rail openings
- lid fasteners for hand operation

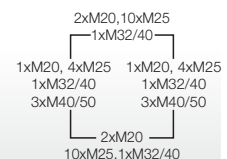
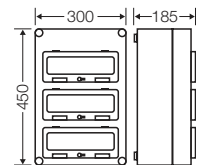

**Mi Distribution Boards**

**Circuit breaker boxes without PE and N terminals with hinged flaps**

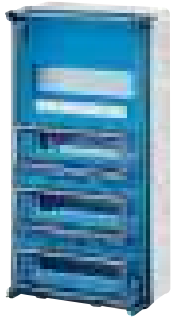

**Mi 1443**

**36 modules: 3 x 12 x 18 mm without PE and N terminal with additional DIN rail**

- 4-row
- with 3 hinged flaps
- hinged flap lockable with accessories
- with 1 DIN rail 216 mm wide (for installation depth of 72 mm)
- for installation of DIN rail equipment in accordance with DIN 43880
- order PE/N terminals separately
- with blanking strips for unused DIN rail openings
- lid fasteners for hand operation

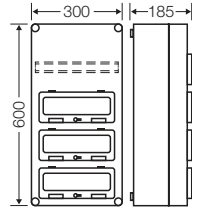

**Mi 1445**

**48 modules: 4 x 12 x 18 mm without PE and N terminal**

- 4-row
- with 4 hinged flaps
- hinged flap lockable with accessories
- for installation of DIN rail equipment in accordance with DIN 43880
- order PE/N terminals separately
- with blanking strips for unused DIN rail openings
- lid fasteners for hand operation

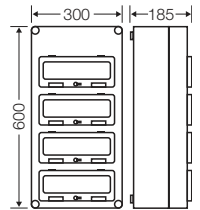

Please note:



Connection box for plug devices, push buttons or switches under accessories

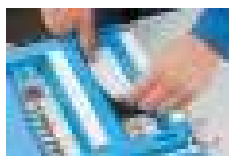

Cover cutouts against direct contact with hazardous live parts



Editable labelling strips: [www.hensel-electric.de](http://www.hensel-electric.de)

**Mi Distribution Boards**  
**Circuit breaker boxes for miniature circuit-breakers (MCB)**

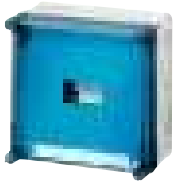

**Mi 1281**

**6 modules: 1 x 6 x 18 mm**  
**for miniature circuit breakers (MCB)**

- 1-row
- with 1-pole main branch terminal for copper conductors
- PEN 2 x 25 mm<sup>2</sup>, 2 x 16 mm<sup>2</sup>, Cu, round conductors
- protection cover can be sealed, with lockable cover strip
- lid fasteners for hand operation

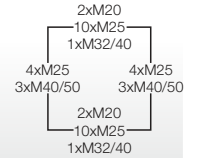
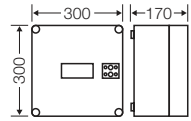

**Note:**

Prepared for the installation of currently commercially available miniature circuit-breakers (MDB)

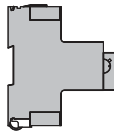

for example  
 ABN Type XHA 3...-4  
 Hager Type HTN..E  
 etc.  
 SHA  
 (voltage dependent)

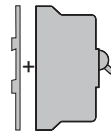

for example  
 ABB Type S 701/S 703  
 + adapter for DIN rail  
 S 700 BT3  
 (1 pc. for S 701, 2 pc. for S 703)  
 SHU (voltage dependent)

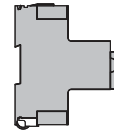

for example  
 ABB Type S 80-...  
 SHU (voltage dependent)

**Mi Distribution Boards**  
**Circuit breaker box**  
**with removable DIN rail rack for earth connection**



**Mi 1118**  
**12 modules: 1 x 12 x 18 mm**  
**without PE and N terminal**

- 1-row
- for installation of DIN rail equipment in accordance with DIN 43880
- order PE/N terminals separately
- with blanking strips for unused DIN rail openings
- lid fasteners for hand operation
- with removable DIN rail rack and earth connection
- DIN rail rack can be earthed

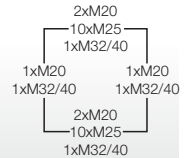
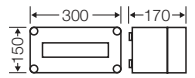

**Mi 1228**  
**24 modules: 2 x 12 x 18 mm**  
**without PE and N terminal**

- 2-row
- for installation of DIN rail equipment in accordance with DIN 43880
- order PE/N terminals separately
- with blanking strips for unused DIN rail openings
- lid fasteners for hand operation
- with removable DIN rail rack and earth connection
- DIN rail rack can be earthed

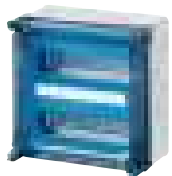
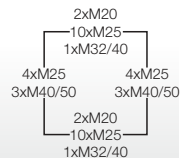
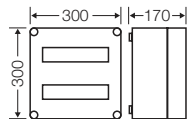

**Mi 1221**  
**24 modules: 2 x 12 x 18 mm**  
**without PE and N terminal**  
**with hinged lid**

- 2-row
- for installation of DIN rail equipment in accordance with DIN 43880
- order PE/N terminals separately
- with blanking strips for unused DIN rail openings
- lid fasteners for hand operation
- with removable DIN rail rack and earth connection
- DIN rail rack can be earthed

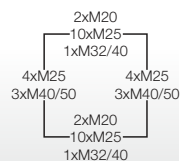
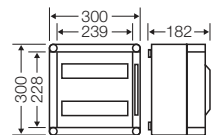

Please note:



Connection box for plug devices, push buttons or switches under accessories

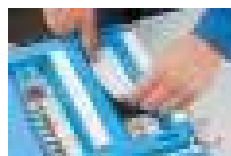

Cover cutouts against direct contact with hazardous live parts



Editable labelling strips: [www.hensel-electric.de](http://www.hensel-electric.de)

**Mi Distribution Boards**  
**Circuit breaker box**  
**with removable DIN rail rack for earth connection**

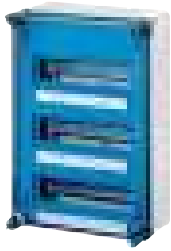

**Mi 1338**  
**36 modules: 3 x 12 x 18 mm**  
**without PE and N terminal**

- 3-row
- for installation of DIN rail equipment in accordance with DIN 43880
- with blanking strips for unused DIN rail openings
- order PE/N terminals separately
- lid fasteners for hand operation
- with removable DIN rail rack and earth connection
- DIN rail rack can be earthed

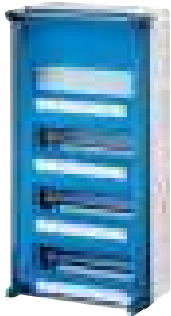
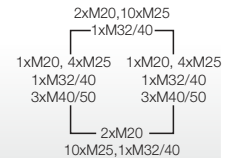
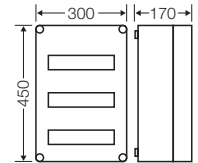

**Mi 1446**  
**36 modules: 3 x 12 x 18 mm**  
**without PE and N terminal**  
**with additional DIN rail**

- 4-row
- with 1 DIN rail 216 mm wide (for installation depth of 72 mm)
- for installation of DIN rail equipment in accordance with DIN 43880
- order PE/N terminals separately
- with blanking strips for unused DIN rail openings
- lid fasteners for hand operation
- with removable DIN rail rack and earth connection
- DIN rail rack can be earthed

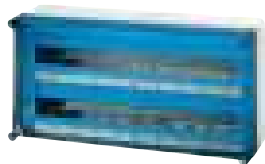
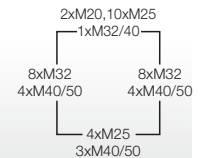
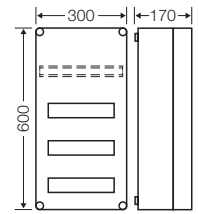

**Mi 1455**  
**56 modules: 2 x 28 x 18 mm**  
**without PE and N terminal**

- 2-row
- for installation of DIN rail equipment in accordance with DIN 43880
- order PE/N terminals separately
- with blanking strips for unused DIN rail openings
- lid fasteners for hand operation
- with removable DIN rail rack and earth connection

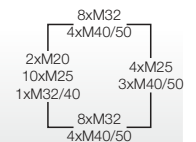
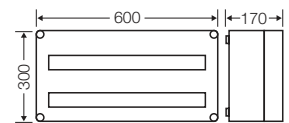

Removable DIN rail rack for earth connection



**Mi Distribution Boards**  
**Circuit breaker box**  
**with removable DIN rail rack for earth connection**

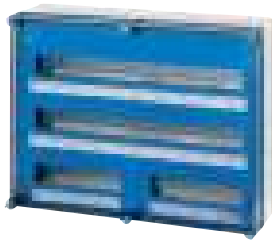

**Mi 1683**

**80 modules: 2 x 28 x 18 mm and 2 x 12 x 18 mm**  
**without PE and N terminal**

- 3-row
- for installation of DIN rail equipment in accordance with DIN 43880
- order PE/N terminals separately
- with blanking strips for unused DIN rail openings
- lid fasteners for hand operation
- with removable DIN rail rack and earth connection

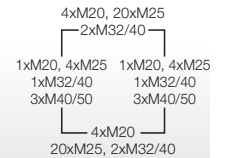
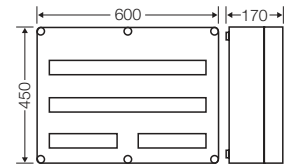

**Mi 1885**

**84 modules: 3 x 28 x 18 mm**  
**without PE and N terminal**

- 3-row
- for installation of DIN rail equipment in accordance with DIN 43880
- order PE/N terminals separately
- with blanking strips for unused DIN rail openings
- lid fasteners for hand operation
- with removable DIN rail rack and earth connection
- cable entry only possible via flange

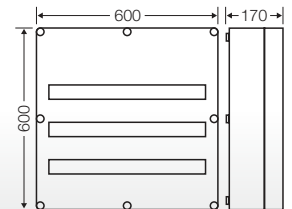

Please note:

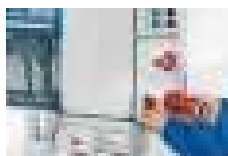

Connection box for plug devices, push buttons or switches under accessories

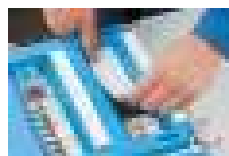

Cover cutouts against direct contact with hazardous live parts



Editable labelling strips: [www.hensel-electric.de](http://www.hensel-electric.de)

**Mi Distribution Boards**  
**Circuit breaker box**  
**with removable DIN rail rack for earth connection**



**Mi 1119**  
**12 modules: 1 x 12 x 18 mm**  
**without PE and N terminal**

- 1-row
- with 1 hinged flap
- hinged flap lockable with accessories
- for installation of DIN rail equipment in accordance with DIN 43880
- order PE/N terminals separately
- with blanking strips for unused DIN rail openings
- lid fasteners for hand operation
- with removable DIN rail rack and earth connection
- DIN rail rack can be earthed

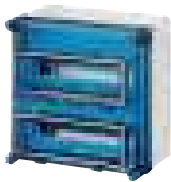
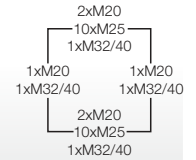
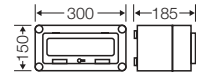

**Mi 1229**  
**24 modules: 2 x 12 x 18 mm**

- 2-row
- with 2 hinged flaps
- hinged flap lockable with accessories
- for installation of DIN rail equipment in accordance with DIN 43880
- without PE and N terminal
- with blanking strips for unused DIN rail openings
- lid fasteners for hand operation
- with removable DIN rail rack and earth connection
- DIN rail rack can be earthed

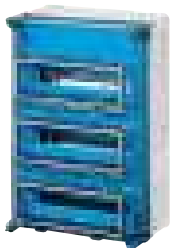
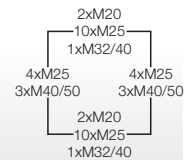
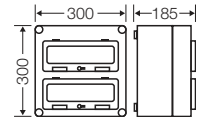

**Mi 1339**  
**36 modules: 3 x 12 x 18 mm**  
**without PE and N terminal**

- 3-row
- with 3 hinged flaps
- hinged flap lockable with accessories
- for installation of DIN rail equipment in accordance with DIN 43880
- order PE/N terminals separately
- with blanking strips for unused DIN rail openings
- lid fasteners for hand operation
- with removable DIN rail rack and earth connection
- DIN rail rack can be earthed

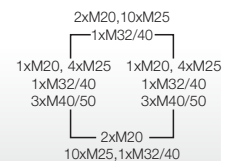
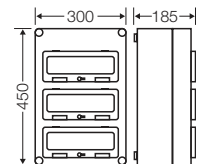

Removable DIN rail rack for earth connection



**Mi Distribution Boards**  
**Circuit breaker box**  
**with removable DIN rail rack for earth connection**



**Mi 1449**  
**48 modules: 4 x 12 x 18 mm**  
**without PE and N terminal**

- 4-row
- with 4 hinged flaps
- hinged flap lockable with accessories
- for installation of DIN rail equipment in accordance with DIN 43880
- order PE/N terminals separately
- with blanking strips for unused DIN rail openings
- lid fasteners for hand operation
- with removable DIN rail rack and earth connection
- DIN rail rack can be earthed

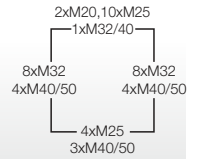
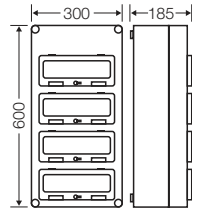

Please note:



Connection box for plug devices, push buttons or switches under accessories

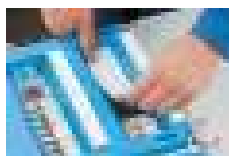

Cover cutouts against direct contact with hazardous live parts



Editable labelling strips:  
[www.hensel-electric.de](http://www.hensel-electric.de)



## Mi Distribution Boards

### Accessories

Connection Box	339
Extension frames, DIN rails, spacers	340 - 341
Mounting plates, fixing screws	342 - 343
Covers, blanking strips	344 - 345
Terminals	346 - 349
Wall gasket, wall separator, fixing spares	350
Flanges, metal inserts for flanges, ventilation flanges	351 - 353
Pressure compensation element, canopy	354 - 355
Conversion kits for lid fasteners	356
Hinges for lids	357
Hinged flap, protection covers for hinged flaps	358
Components for wall mounting	359 - 360



**Mi CB 10**  
**Connection Box**

- for the installation of devices that must be operated externally, such as plug devices, push buttons and switches
- for mounting to box walls 300 mm
- hinged mounting area
- with wall gasket

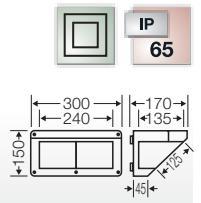

Application:



Connection box for plug devices, push buttons or switches under accessories



**Mi ZR 4**  
**Extension frame**  
**for enclosure size 4**

- for extension of the installation depth by 85 mm
- degree of protection IP 65 is maintained with use of up to two extension frames
- inclusive fixing material

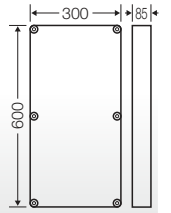

**Mi ZR 8**  
**Extension frame**  
**for enclosure size 8**

- for extension of the installation depth by 85 mm
- degree of protection IP 65 is maintained with use of up to two extension frames
- inclusive fixing material

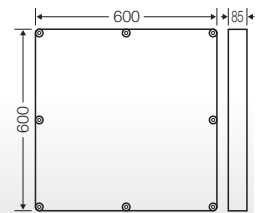

Application:

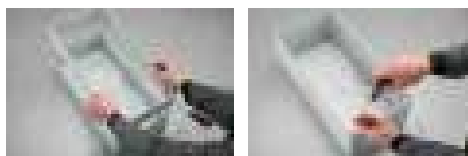

Increased enclosure depths of 85 mm using extension frames



**Mi TS 15**

**DIN rail**  
**length 134 mm**

- in accordance with DIN EN 60715
- for Mi-Empty boxes sizes 1, 6
- for equipment or terminals with clip-on mounting
- with fixing screws

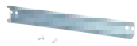
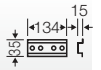

**Mi TS 30**

**DIN rail**  
**length 284 mm**

- in accordance with DIN EN 60715
- for Mi-Empty boxes sizes 1, 2, 3, 4, 6, 8
- for equipment or terminals with clip-on mounting
- with fixing screws

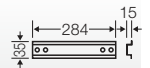

**Mi TS 45**

**DIN rail**  
**length 434 mm**

- in accordance with DIN EN 60715
- for Mi-Empty boxes sizes 3, 6
- for equipment or terminals with clip-on mounting
- with fixing screws

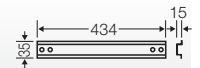

**Mi TS 60**

**DIN rail**  
**length 584 mm**

- in accordance with DIN EN 60715
- for Mi-Empty boxes sizes 4, 6, 8
- for equipment or terminals with clip-on mounting
- with fixing screws

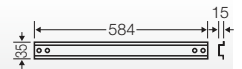

**Mi DS 25**

**Spacer**  
**height: 25 mm**

- for spacing DIN-rails Mi TS ..
- 2 pieces
- with fixing screws for base of box and DIN rail



**Mi DS 50**

**Spacer**  
**height: 50 mm**

- for spacing DIN-rails Mi TS ..
- 2 pieces
- with fixing screws for base of box and DIN rail

Application:



DIN rails for equipment or terminals with clip-on mounting



**Mi MP 1**

**mounting plate**  
**W 259 x H 115 mm**

- material thickness 4 mm
- for Mi-Empty boxes sizes 1, 2, 3, 4, 6
- with fixing screws



**Mi MP 2**

**mounting plate**  
**W 265 x H 265 mm**

- material thickness 4 mm
- for Mi-Empty boxes sizes 2, 3, 4, 6, 8
- with fixing screws

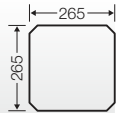

**Mi MP 3**

**mounting plate**  
**W 265 x H 415 mm**

- material thickness 4 mm
- for Mi-Empty boxes sizes 3, 4, 6
- with fixing screws

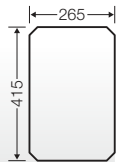

**Mi MP 4**

**mounting plate**  
**W 265 x H 565 mm**

- material thickness 4 mm
- for Mi-Empty boxes sizes 4, 6, 8
- with fixing screws

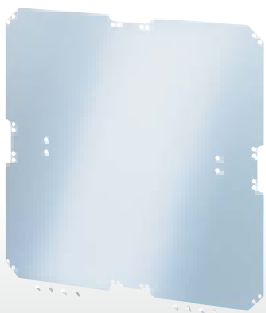
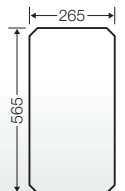

**Mi MP 8**

**mounting plate**  
**W 565 x H 565 mm**

- material thickness 4 mm
- for Mi Empty box size 8
- with fixing screws

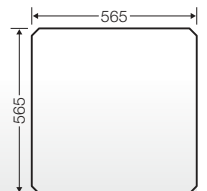

Application:

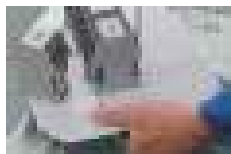

Mounting plates for the installation of electrical devices

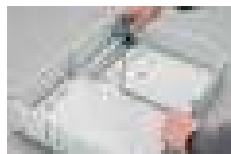

Mounting plates of various sizes in one enclosure

**Mi BZ 11****fixing screw**  
**length 11 mm**

- for assembling DIN rails or mounting plates at the base of the box
- for material thicknesses of 1 to 2.5 mm
- self-tapping
- galvanised

**Mi BZ 13****fixing screw**  
**length 13 mm**

- for assembling DIN rails or mounting plates at the base of the box
- for material thicknesses of 2.5 to 4 mm
- self-tapping
- galvanised

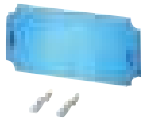

**Mi EP 01**  
**Cover**  
**for Mi Empty box size 1**

- for retrofitting
- cover without cut-outs made of plastics, as protection cover or for the installation of devices
- with fastening material

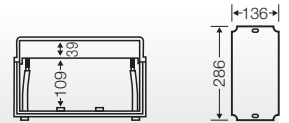

**Mi EP 02**  
**Cover**  
**for Mi Empty box size 2**

- for retrofitting
- cover without cut-outs made of plastics, as protection cover or for the installation of devices
- with fastening material

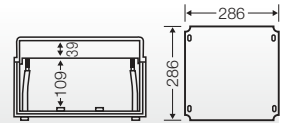

**Mi EP 03**  
**Cover**  
**for Mi-Empty boxes sizes 3, 6**

- for retrofitting
- 2 covers are required for Mi empty enclosure size 6
- cover without cut-outs made of plastics, as protection cover or for the installation of devices
- with fastening material

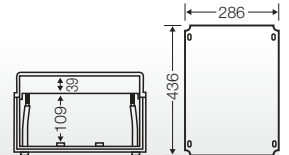

**Mi EP 04**  
**Cover**  
**for Mi Empty box size 4**

- for retrofitting
- cover without cut-outs made of plastics, as protection cover or for the installation of devices
- with fastening material

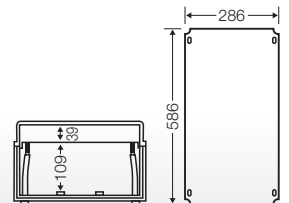

Application:

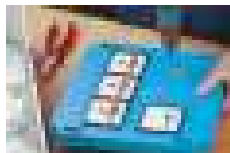

Covers for protection of installation device, see accessories

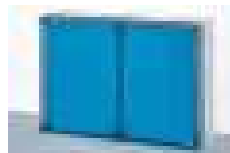

2 covers are required for Mi empty enclosure size 6

**AS 12****Blanking strip  
12 modules**

- 12 x 18 mm, divisible every 9 mm
- for the covering of spare equipment openings, for material thickness up to 3 mm

**AS 18****Blanking strip  
18 modules**

- 18 X 18 mm, divisible every 9 mm
- for the covering of spare equipment openings, for material thickness up to 3 mm

**DAE 12****Spacer**

- for improvement in the heat dissipation of DIN rail mounted devices
- consisting of 12 items

Application:

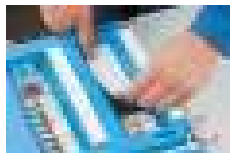

Cover cutouts against direct contact with hazardous live parts



### KKL 25

#### Connecting terminal

#### Rated connecting capacity: 6-35 mm<sup>2</sup>, Cu

- as a connecting terminal
- for installation on DIN rails in accordance with IEC 60715, top hat profile 35 mm
- current carrying capacity: 102 A
- 1-pole 6 x 6 mm<sup>2</sup> sol, 6 x 10 mm<sup>2</sup> sol/ f\*, 4 x 16 mm<sup>2</sup> s/ f\*, 4 x 25 mm<sup>2</sup> s/ f\*, 2 x 35 mm<sup>2</sup> s/ f\* each  
f\* = with gas-tight end ferrule
- with two connected clamping units

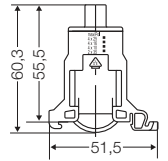

rated insulation voltage	U <sub>i</sub> = 690 V a.c./d.c.
dismantling length	16 mm
tightening torque for terminal	3.0 Nm



**FC L 10**

**Terminal**

**2 x 25 mm<sup>2</sup>, 8 x 4 mm<sup>2</sup>, Cu**

- for installation on DIN rails in accordance with IEC 60715, top hat profile 35 mm
- FIXCONNECT® plug-in technology, for terminal technology refer to index technical data
- current carrying capacity: 101 A

rated insulation voltage

U<sub>i</sub> = 690 V a.c.

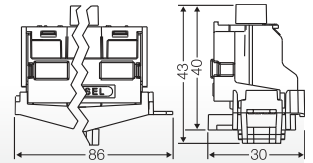

**FC N 10**

**N terminal**

**2 x 25 mm<sup>2</sup>, 8 x 4 mm<sup>2</sup>, Cu**

- for installation on DIN rails in accordance with IEC 60715, top hat profile 35 mm
- FIXCONNECT® plug-in technology, for terminal technology refer to index technical data
- current carrying capacity: 101 A

rated insulation voltage

U<sub>i</sub> = 690 V a.c.

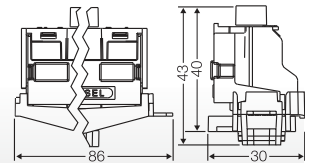

**FC PE 10**

**PE terminal**

**2 x 25 mm<sup>2</sup>, 8 x 4 mm<sup>2</sup>, Cu**

- for installation on DIN rails in accordance with IEC 60715, top hat profile 35 mm
- for boxes with 1 x 12 modules (through terminal reduction to 9 modules)
- FIXCONNECT® plug-in technology, for terminal technology refer to index technical data

rated insulation voltage

U<sub>i</sub> = 690 V a.c.

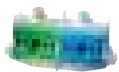
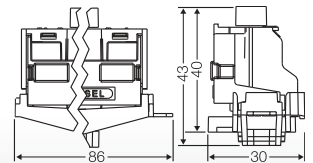

**FC PN 10**

**PE and N terminal**

**per PE/N 1 x 25 mm<sup>2</sup>, 4 x 4 mm<sup>2</sup> Cu**

- for installation on DIN rails in accordance with IEC 60715, top hat profile 35 mm
- FIXCONNECT® plug-in technology, for terminal technology refer to index technical data
- current carrying capacity: 101 A

rated insulation voltage

U<sub>i</sub> = 690 V a.c.

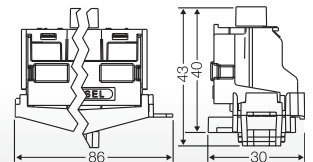

**FC BS 5**

**FIXCONNECT labelling system set with 5 pieces**

- labelling system for FIXCONNECT® plug-in terminals, not for terminals 2x25 / 4x4 mm<sup>2</sup>
- for attaching of labelling strips or marking with felt tip pen

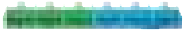

**FC PN 30**

**PE and N terminal**  
per PE/N 3 x 25 mm<sup>2</sup>, 12 x 4 mm<sup>2</sup>, Cu

- 1-row
- FIXCONNECT® plug-in technology, for terminal technology refer to index technical data
- N separable, for up to 2 different potentials
- with fastening material
- current carrying capacity: 75 A

rated insulation voltage	Ui = 690 V a.c.
--------------------------	-----------------

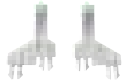
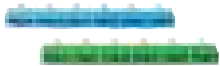

**FC PN 60**

**PE and N terminal**  
per PE/N 6 x 25 mm<sup>2</sup>, 24 x 4 mm<sup>2</sup>, Cu

- 2-row
- FIXCONNECT® plug-in technology, for terminal technology refer to index technical data
- N separable, up to 4 different potentials
- with fastening material
- current carrying capacity: 75 A
- Not applicable in boxes Mi 1456, Mi 1455, Mi 1884 and Mi 1885

rated insulation voltage	Ui = 690 V a.c.
--------------------------	-----------------



**FC N 30**

**N terminal**  
per N 6 x 25 mm<sup>2</sup>, 24 x 4 mm<sup>2</sup>, Cu

- 1-row
- FIXCONNECT® plug-in technology, for terminal technology refer to index technical data
- N separable, up to 4 different potentials
- with fastening material
- current carrying capacity: 75 A

rated insulation voltage	Ui = 690 V a.c.
--------------------------	-----------------



**FC PE 30**

**PE terminal**  
per PE 6 x 25 mm<sup>2</sup>, 24 x 4 mm<sup>2</sup>, Cu

- 1-row
- FIXCONNECT® plug-in technology, for terminal technology refer to index technical data
- with fastening material

rated insulation voltage	Ui = 690 V a.c.
--------------------------	-----------------



**KKL 34**

**Main line branch terminal**

**Rated connecting capacity: 1.5-25 mm<sup>2</sup>, Cu**

- as a connecting terminal
- for installation on DIN rails in accordance with IEC 60715, top hat profile 35 mm
- connections per terminal L1-L3: 4x
- connection: 1.5-16 mm<sup>2</sup> f\* or 2.5-25mm<sup>2</sup>, Cu, round conductor  
f\* = with gas-tight end ferrule
- current carrying capacity: 80 A
- width: 61 mm



dismantling length	19 mm
tightening torque for terminal	2,5 Nm



**KKL 48**

**Main line branch terminal**

**Rated connecting capacity: 1.5-25 mm<sup>2</sup>, Cu**

- as a connecting terminal
- for installation on DIN rails in accordance with IEC 60715, top hat profile 35 mm
- connections per terminal L1-L3, 4x  
connections per terminal N: 8x
- connection: 1.5-16 mm<sup>2</sup> f\* or 2.5-25mm<sup>2</sup>, Cu, round conductor  
f\* = with gas-tight end ferrule
- current carrying capacity: 80 A
- width: 100 mm



dismantling length	19 mm
tightening torque for terminal	2,5 Nm

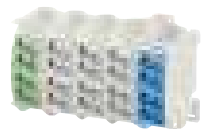

**KKL 54**

**Main line branch terminal**

**Rated connecting capacity: 1.5-25 mm<sup>2</sup>, Cu**

- as a connecting terminal
- for installation on DIN rails in accordance with IEC 60715, top hat profile 35 mm
- connections per terminal L1-L3: 4x  
connections per terminal N: 4x  
connections per terminal PE: 4x
- connection: 1.5-16 mm<sup>2</sup> f\* or 2.5-25mm<sup>2</sup>, Cu, round conductor  
f\* = with gas-tight end ferrule
- current carrying capacity: 80 A
- width: 100 mm



dismantling length	19 mm
tightening torque for terminal	2,5 Nm

**Mi WD 2**
**Wall gasket**  
**for box walls 150/300 mm**

- for the assembly of Mi boxes
- consisting of 1 seal, 4 wedge links, 1 bracket

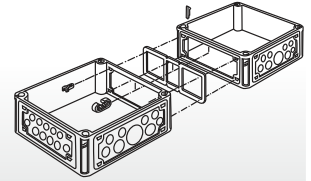
**Mi WT 1**
**Wall separator**

- for subdivision of 300 mm box walls into 2 x 150 mm in case of flange or box assembly

**Mi BE**
**Fixing spares**  
**4 connectors**

- for the assembly of Mi boxes
- when converting existing installations



**Mi FP 15**

**Flange**  
**without knockouts**

- box wall 150 mm
- with fixing wedges and seal

mounting width	65 mm
mounting height	88 mm

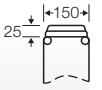

**Mi FM 15**

**Flange**  
**knockouts 3 x M 20, 1 x M 32/40/50**

- box wall 150 mm
- with fixing wedges and seal

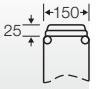

**Mi FP 20**

**Flange**  
**without knockouts**

- box wall 300 mm
- with fixing wedges and seal

mounting width	215 mm
mounting height	88 mm

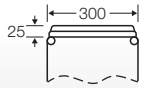

**Mi FM 20**

**Flange**  
**knockouts 15 x M 16, 15 x M 20**

- box wall 300 mm
- with fixing wedges and seal

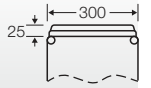

**Mi FM 25**

**Flange**  
**knockouts: 19 x M 16/25**

- box wall 300 mm
- with fixing wedges and seal

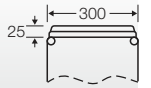

**Mi FM 32**

**Flange**  
**knockouts: 8 x M 25/32, 1 x M 25/32/40**

- box wall 300 mm
- with fixing wedges and seal

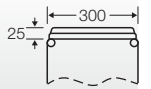

**Mi FM 40**

**Flange**  
**knockouts: 2 x M 25/32, 5 x M 32/40**

- box wall 300 mm
- with fixing wedges and seal

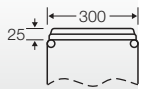



**Mi FM 50**

**Flange**  
**knockouts: 2 x M 20, 4 x M 32/40/50**

- box wall 300 mm
- with fixing wedges and seal

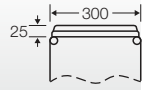

**Mi FM 60**

**Flange**  
**knockouts: 3 x M 40/50/63**

- box wall 300 mm
- with fixing wedges and seal

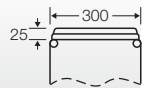

**Mi FM 63**

**Flange with cable arrangement space**  
**knockouts: 3 x M 40/50/63**

- box wall 300 mm
- with fixing wedges and seal

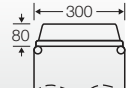

**Mi FP 38**

**Flange**  
**sealing range Ø 7-29 mm**

- cable entry via integrated elastic membranes
- sealing range: 29 x Ø 7-12 mm, 4 x Ø 7-14 mm, 4 x Ø 11-20 mm, 1 x Ø 16-29 mm
- box wall 300 mm
- with fixing wedges and seal

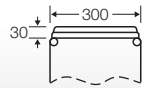

**Mi FP 70**

**Flange**  
**sealing range: 1 x Ø 30-72 mm**

- box wall 300 mm
- with fixing wedges and seal

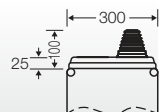

**Mi FP 72**

**Flange**  
**sealing range: 2 x each Ø 30-72 mm**

- box wall 300 mm
- with fixing wedges and seal

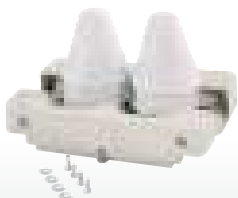
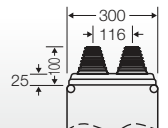

**Mi FP 82**

**Cable insert**  
**sealing range: 2 x each Ø 30-72 mm**

- box wall 300 mm
- divisible for cable insertion from the front
- degree of protection IP 54 only with additional strain and pressure relief (e.g. Mi ZE 62)

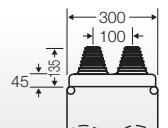



**KST 82**

**Stepped grommet**  
sealing range: Ø 30-72 mm

- for retrofitting of cable insertion Mi FP 82
- for indoor - normal environment and (or) protected outdoor installation
- ambient temperature - 25 °C to + 35 °C



**Mi FP 30**

**Metal insert for flanges**

- for earthing of metal armoured cables
- box wall 300 mm
- without knockouts

mounting width	215 mm
mounting height	88 mm



**Mi ZE 62**

**Cable strain relief**  
for 2 cables with max. 60 mm external diameter

- with fixing rail 284 mm long
- to be used only in connection with cable insertion Mi FP 82



**Mi GS 30**

**Box fin**  
for inserting cables across 2 boxes

- for box walls 300 mm
- removable
- can be retrofitted



**Mi BF 44**

**Ventilation flange**  
for vertical installation on box walls

- box wall 300 mm
- for ventilation of Mi-Distribution boards in the event of extremely high internal temperatures or a risk of water condensation



**BE 44**

**Ventilation insert**



Application:

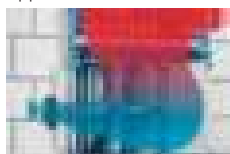

Ventilation via ventilation flange or ventilation insert



### BM 20G

#### Pressure compensation element for M 20 knockouts

- for the reduction of condensation by pressure compensation in power distribution systems
- ISO thread M 20 x 1.5
- bore-hole: Ø 20.3 mm
- wall thickness up to 4 mm
- with counter nut
- for indoor (normal environment and/or protected outdoor) and outdoor installation (harsh environment and/or outdoor)
- ambient temperature - 25 °C to + 55 °C
- In order not to exceed leakage limit of 0.07 bar with pressure compensation, one pressure compensation element BM 20G must be used per 28 litres (28000 cm<sup>3</sup>) of enclosure volume.
- Example: enclosure size 30 cm x 60 cm x 17 cm = 30600 cm<sup>3</sup> = 30,6 litres. Number of necessary BM 20G (M32) = 2 piece.
- technical changes reserved
- Colour: grey, RAL 7035

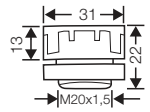

### BM 40G

#### Pressure compensation element for M 40 knockouts

- for the reduction of condensation by pressure compensation in power distribution systems
- ISO thread M 40 x 1.5
- bore-hole: Ø 40.3 mm
- wall thickness of up to 8 mm
- with counter nut
- for indoor (normal environment and/or protected outdoor) and outdoor installation (harsh environment and/or outdoor)
- ambient temperature - 25 °C to + 55 °C
- In order not to exceed leakage limit of 0.07 bar with pressure compensation, one pressure compensation element BM 40G must be used per 122 litres (122000 cm<sup>3</sup>) of enclosure volume.
- Example: enclosure size 60 cm x 60 cm x 17 cm = 61200 cm<sup>3</sup> = 61,2 litres. Number of necessary BM 40G (M40) = 1 piece.
- technical changes reserved
- Colour: grey, RAL 7035

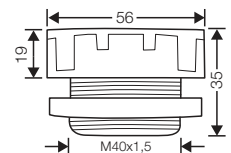

Pressure compensation element

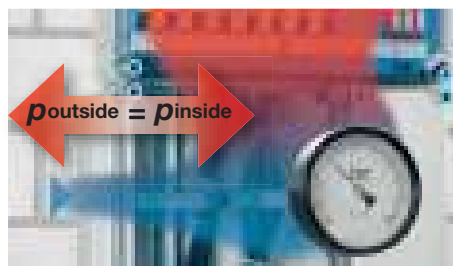



**Mi DB 15**  
**Canopy**  
**for box wall 150 mm**

- with fixing wedges and seal
- suitable for outdoor installation, UV resistant

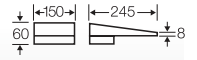

material	stainless steel powder-coated
----------	-------------------------------



**Mi DB 30**  
**Canopy**  
**for 300 mm box walls**

- with fixing wedges and seal
- suitable for outdoor installation, UV resistant



material	stainless steel powder-coated
----------	-------------------------------



**Mi DB 01**  
**Canopy end plate**

- for canopies FP DB xx and Mi DB xx

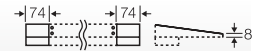

material	stainless steel powder-coated
----------	-------------------------------

Application:



Canopy

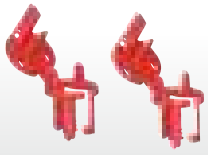

**Mi PL 2**  
**Sealing cap**

- 2 sealing caps for converting the lid fasteners



**Mi SR 4**  
**Conversion set for manual operation on tool operation**

- 4 fastening covers



**Mi SN 4**  
**Conversion set for converting lid fasteners from tool to manual operation**

- 4 manual actuators



**Mi DV 01**  
**Locking device insertion**

- only in connection with Mi PL 2, Mi SR 4 or Mi SN 4



**Mi ZS 11**  
**Lid lock with locking device I for Mi boxes sizes 1 to 6**

- Is being used instead of fasteners for hand or tool operation in order to prevent unauthorised opening of the lids
- consisting of: cylinder lock, keys, locking device insertion, dust cover

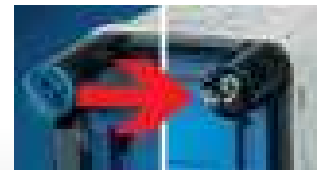

**Mi ZS 12**  
**Lid lock with locking device II for Mi boxes sizes 1 to 6**

- Is being used instead of fasteners for hand or tool operation in order to prevent unauthorised opening of the lids
- consisting of: cylinder lock, keys, locking device insertion, dust cover

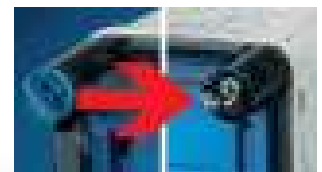

**Mi DR 04**  
**Lid fastener for tool operation triangle 8 mm**

- is used instead of fasteners for hand- or tool operation, in order to make unauthorized opening of lids more difficult
- 4 locking devices with triangle 8 mm and key



**DS 1**  
**Triangular key 8 mm**



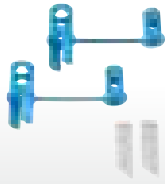

**Mi SV 2**

**Conversion set  
for padlock (clip Ø max. 10 mm)**

- 2 fastening covers
- can be used instead of fasteners for hand or tool operation in order to prevent unauthorised opening of the lids

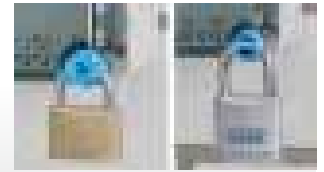

**Mi ZS 20**

**Mi hinge for lids  
for Mi boxes sizes 1, 2, 3, 4**

- For operating installation device within a large area. The lid keeps permanently connected to the box.
- When assembling several boxes, the insertion can only be carried out for the external boxes.



**Mi ZS 40**

**Mi hinge for lids  
for Mi boxes sizes 1 to 8**

- For operating installation device within a large area. The lid keeps permanently connected to the box.
- Wall connectors or flanges are necessary for assembly
- Not applicable in boxes with covers



**Mi ZS 60**

**Mi hinge for lids  
for Mi boxes sizes 4 and 8 with extension frame**

- For operating installation device within a large area. The lid keeps permanently connected to the box.
- Wall connectors or flanges are necessary for assembly
- Not applicable in boxes with covers

Application:

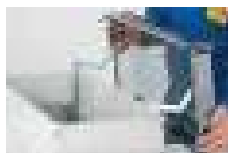

Mi hinges for lids for operating within a large area

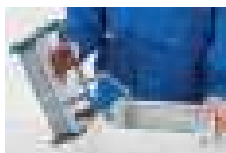

Mi hinges for lids for operating within a large area



**Mi KL 6**  
**Hinged flap**  
opening dimensions 117 x 60 mm

IP  
65

- with drill and saw template
- modules 1 x 6 x 18 mm
- sealable
- lockable with hinged flap lock
- inclusive fixing material
- wall thickness 1.5-4.5 mm

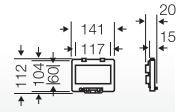

**Mi KL 12**  
**Hinged flap**  
opening dimensions 220 x 60 mm

IP  
65

- with drill and saw template
- modules 1 x 12 x 18 mm
- sealable
- lockable with hinged flap lock
- inclusive fixing material
- wall thickness 1.5-4 mm

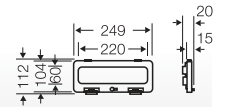

**Mi BS 6**  
**Protection cover**  
for Mi KL 6

- with fixing screws

modules	6 1 x 6 x 18 mm
---------	--------------------

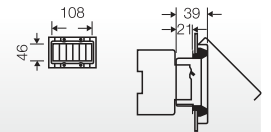

**Mi BS 12**  
**Protection cover**  
for Mi KL 12

- with fixing screws

modules	12 1 x 12 x 18 mm
---------	----------------------

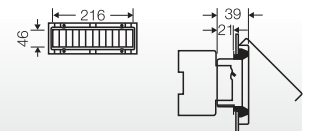

**Mi SK 01**  
**Hinged flap lock**

- for retrofitting in hinged flaps of 6 or 12 modules width
- for protecting the switchgear located behind the hinged flap against unauthorised access (only effective in connection with lid lock Mi ZS ..)
- consisting of:
- 1 lock (Mi KL), 2 keys, 1 grooved pin

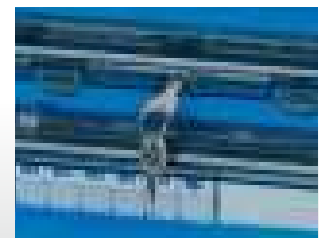

**NZ KL 54**  
**KWH meter window flap**  
standard opening dimensions 140 x 310 mm

IP  
54

- in accordance with DIN 43 870
- for tool or manual operation
- can be locked with padlock (clip diameter max. 6 mm)
- complete with screws
- sealable

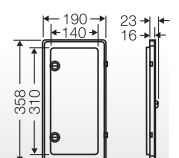



**Mi SA 2**

**Dust protection cover**

- for box sizes 1 to 4
- for 2 lid fittings



**Mi AL 40**

**4 stainless steel external brackets**

- for external fixing of enclosures

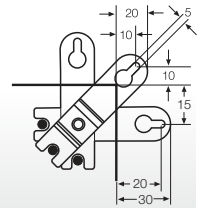

**Mi MS 2**

**Profile for wall mounting**

- for Mi distribution board assemblies up to 900 x 1200 mm
- with 8 screws M6 x 16, washers and nuts for mounting enclosures

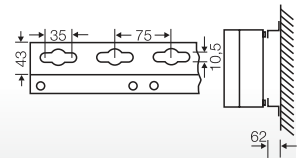

length	1950 mm
material	sendzimir galvanised steel profile with structured powder coating

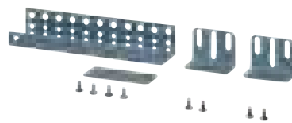

**MX 0101**

**Mounting profile set**

**U-profile for constructing a mounting frame**

- consisting of:  
1 x mounting rail, 2 x fixing brackets,  
1 x flat connector with connecting screws

length	1950 mm
material	sheet steel, galvanised and powder-coated



**MX 0112**

**frame connector set**

**for constructing a mounting frame**

- fixing elements for T or L connections
- consisting of: 2 couplers with screws and nuts

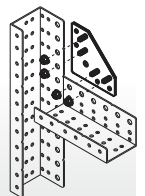

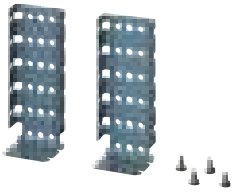
**MX 0105****Coupler set  
for constructing a mounting frame**

- 2 x couplers with connecting screws

material

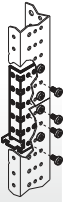
sheet steel, galvanised and  
powder-coated**MX 0111****Screw for box fixing**

- set with 12 pieces
- M 6 x 16
- self-tapping for fixing the Mi box onto mounting profile MX 0101

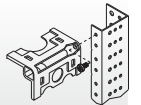
**Varnishing pen RAL 7016****12 ml**



## Mi Distribution Boards

### Technical details

Operating and ambient conditions	362
Standards and regulations	363
Dimensions in mm	364
Terminals	365
Power dissipation of empty enclosures	366 - 367
Box assembly	368 - 370
Device installation, wall mounting	371 - 373

	Empty enclosures Mi 0... Mi 9...	Circuit breaker boxes Mi 1...
<b>Application area</b>	<b>Suitable for indoor installation and outdoor installation, protected against weather influences</b> However, pay attention to the climatic effects on the installed equipment , for example, high or low ambient temperatures or formation of condensed water see technical information	
	<b>Resistance to occasional cleaning procedures (direct jet)</b> with high-pressure cleaner without cleaning additives, water pressure: max 100 bar, water temperature: Max. 80 °C, distance => 0.15 m, in accordance with IP 69K requirements, single enclosure without lid equipment (no enclosure assembly), <b>enclosure and cable glands at least IP 65.</b>	
<b>Ambient temperature</b>		
- Average value over 24 hours	-	+ 35 °C The ambient temperature is reduced
- Maximum value	+ 70 °C	+ 40 °C at distribution boares by the installed
- Minimum value	- 25 °C	- 5 °C equipment technology!
<b>Relative humidity</b>		
- short-time	-	50% at 40 °C 100% at 25 °C
<b>Fire protection</b> in the event of internal faults	Demands placed on electrical devices from standards and laws:  Minimum requirements - Glow wire test in accordance with IEC 60 695-2-11: - 650 °C for boxes and cable glands - 850 °C for conducting components	
<b>Burning behaviour</b>		
- Glow wire test IEC 60 695-2-11	960 °C	960 °C
- UL Subject 94	V-2 flame-retardant self-extinguishing	V-2 flame-retardant self-extinguishing
<b>Degree of protection against mechanical load</b>	IK 08 (5 Joule)	IK 08 (5 Joule)
<b>Toxic behaviour</b>	halogenfree <sup>1)</sup> silicone-free	halogenfree <sup>1)</sup> silicone-free

<sup>1)</sup> "Halogen-free" in accordance with IEC 60754-2"  
Common test methods for cables - Determination of the amount of halogen acid gas".

For material properties see technical data.

**Mi Distribution Boards  
comply with the require-  
ments of the IEC 61439-2**

Distribution boards assembled and wired according to manufacturer data without essential deviations from the original type or system.

To meet these requirements for Hensel Mi Distribution Boards, the following must be noted:

1. The distribution boards must consist of the verified enclosures documented in this list.
2. The wiring of the equipment must be carried out with the cross-sections and conductor types indicated in Table "Rating of insulated conductors in switchgear assemblies", Index Techniques.
3. Once the distribution board is completed, a routine test must be carried out in accordance with this standard.
4. The test must be certified with a test report.
5. The assembly must be provided with a manufacturer's identification mark.  
Compliance with important data such as
  - limit of temperature rise
  - dielectric strength
  - IP degrees of protection
  - creepage distances and clearances
 is verified for this system.

**Standards and regulations**

- IEC 61439-2  
Low-voltage switchgear and controlgear assemblies –  
Part 2: Power switchgear and controlgear assemblies
- IEC 60999, connecting devices  
Safety requirements for screw-type and screwless-type clamping units  
for electrical copper conductors
- DIN EN 50262  
Metric threaded cable glands for electrical installations
- DIN 43880  
Built-in equipment for electrical installations; overall dimensions  
and related mounting dimensions
- IEC 60529  
Degrees of protection provided by enclosures (IP-Code)

Technical details  
Dimensions in mm

Dimensions of the interior installation depth with installed mounting plates.

The width of Mi Empty boxes Mi 9... enlarges about 15 mm because of the laterally mounted lid hinges, refer to product pages.

 = usable installation space with mounted cable glands

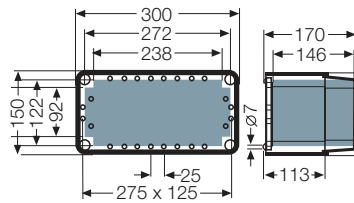

Mi 0100  
Mi 0101  
Mi 9100  
Mi 9101

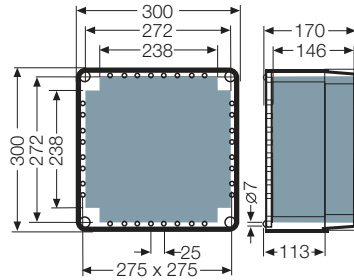

Mi 0200  
Mi 0201  
Mi 9200  
Mi 9201

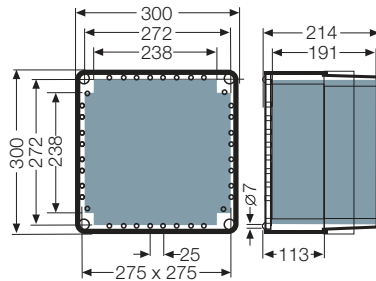

Mi 0210  
Mi 0211  
Mi 9210  
Mi 9211

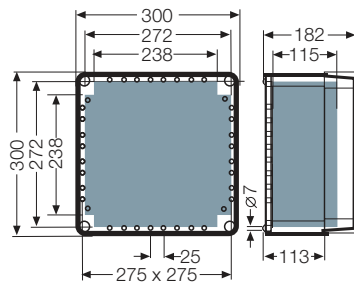

Mi 0220  
Mi 0221

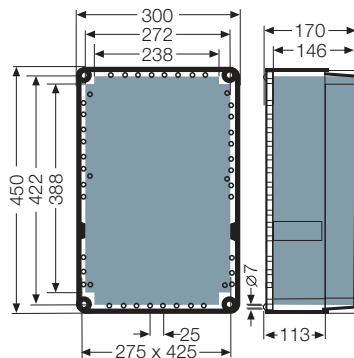

Mi 0300  
Mi 0301  
Mi 9310  
Mi 9311

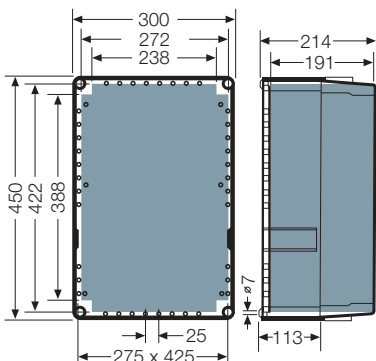

Mi 0310  
Mi 0311  
Mi 9310  
Mi 9311

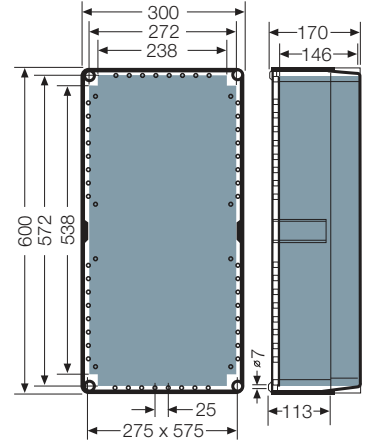

Mi 0400  
Mi 0401  
Mi 9400  
Mi 9401

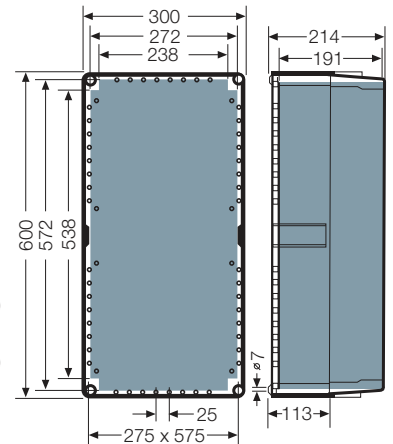

Mi 0410  
Mi 0411  
Mi 9410  
Mi 9411

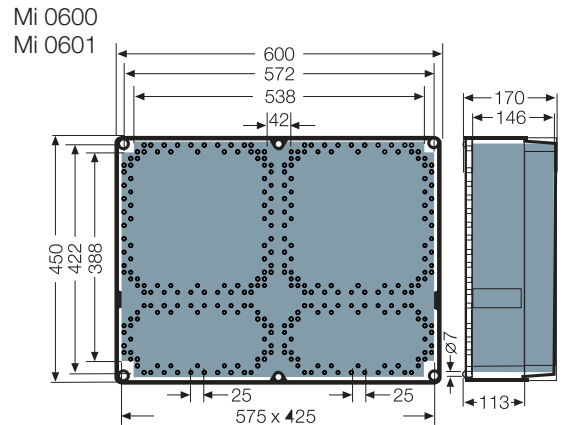

Mi 0600  
Mi 0601

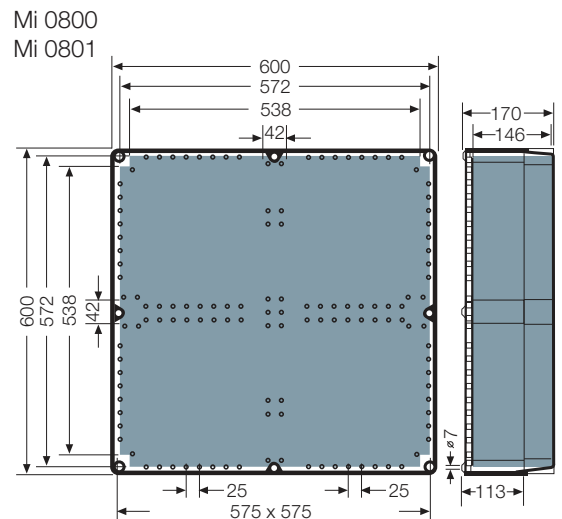

Mi 0800  
Mi 0801

Installation of equipment in protection plates:

Pre-drill the sections at the corners, then saw away the section from the protection plate by using a piercing saw at middle to low cutting speed.

Use coarse toothed saw blades for plastics (e.g. Bosch T 101 B).

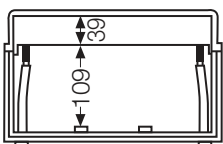



Technical details  
Terminals

PE und N  
FIXCONNECT®-Klemme

Rated connecting capacity  
of PE and N terminals





Current carrying capacity:  
75 A

Clamping unit	Corresponding cross-sections / copper			
	max. number	from - to max.	max. number	from - to max.
 Screw-type terminal 25 mm²	1	25 mm², s	1	25 mm², f
	1	16 mm², s	1	16 mm², f
	1	10 mm², sol	1	10 mm², f
	3	6 mm², sol	1	6 mm², f
	3	4 mm², sol	1	4 mm², f
	4	2.5 mm², sol	1	2.5 mm², f
4	1.5 mm², sol	1	1.5 mm², f	
 Plug-in terminal 4 mm²	1	1.5 - 4 mm², sol	1	1.5 - 4 mm², f
				Without end ferrule; clamping unit has to be opened with a tool when conductor is inserted.





} Tested as connecting terminal for several conductors of the same cross-sections for using in one circuit

Terminal equipment  
and number of conductors  
to be connected

PE terminal

Number of modules	Mounted in Mi Circuit breaker boxes	PE terminal	
		 up to 4 mm²	 up to 25 mm²
24 (2-row)	Mi 1224		
	Mi 1220		
	Mi 1222	12x4 mm²	2x25 mm²
36 (3-row)	Mi 1336		
	Mi 1333		
48 (4-row)	Mi 1448	24x4 mm²	6x25 mm²
	Mi 1444		

N terminal

Number of modules	Mounted in Mi Circuit breaker boxes	N terminal		 plug-in jumper
		 up to 4 mm²	 up to 25 mm²	
24 (2-row)	Mi 1224			
	Mi 1220			
	Mi 1222	12x4 mm²	3x25 mm²	
36 (3-row)	Mi 1336			
	Mi 1333			
48 (4-row)	Mi 1448	24x4 mm²	6x25 mm²	
	Mi 1444			

Temperature rise ( $\Delta\theta$ ) with Mi-Distribution boards by power dissipation of electrical devices

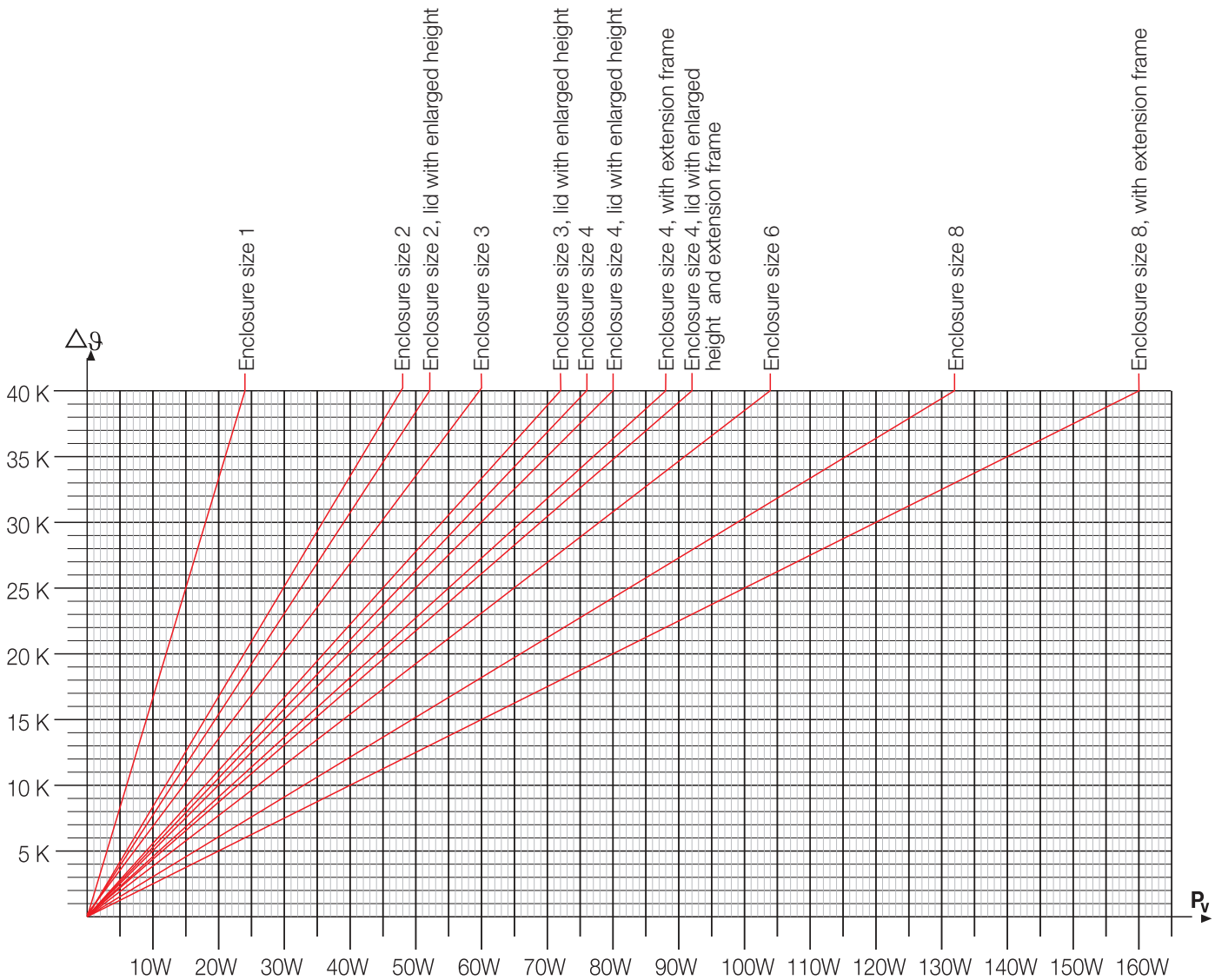

Mi distribution boards enclosure sizes	dimensions (WxHxD) in mm	rated power dissipation Pv in watts per Kelvin assembled enclosures
enclosure size 1	300 x 150 x 170	0.6
enclosure size 2	300 x 300 x 170	1.2
enclosure size 2, lid with enlarged depth	300 x 300 x 214	1.3
enclosure size 3	300 x 450 x 170	1.5
enclosure size 3, lid with enlarged depth	300 x 450 x 214	1.8
enclosure size 4	300 x 600 x 170	1.9
enclosure size 4, lid with enlarged depth	300 x 600 x 214	2.0
enclosure size 4 with extension frame	300 x 600 x 255	2.2
enclosure size 4, lid with enlarged depth and extension frame	300 x 600 x 299	2.3
enclosure size 6	450 x 600 x 170	2.6
enclosure size 8	600 x 600 x 170	3.3
enclosure size 8 with extension frame	600 x 600 x 255	4.0

**Note!**

The maximally permissible operating temperature inside the enclosures ( $\vartheta_{i\max}$ ) is determined by:

- 1<sup>st</sup> maximally permissible ambient temperature of the installed electrical devices (please consider data of the equipment manufacturers)
- 2<sup>nd</sup> category temperature of the internal wiring and the inserted cables
- 3<sup>rd</sup> temperature resistance of the enclosure materials and the cable entries etc.

**Example: calculation of the maximum rated power dissipation ( $P_v$ )**

maximally permissible operating temperature inside the enclosure(s) ( $\vartheta_{i\max}$ ):	e.g. 55 °C
ambient temperature of the enclosure(s) ( $\vartheta_U$ ):	25 °C
maximally permissible heating up inside the enclosure:	$\Delta\vartheta = \vartheta_{i\max} - \vartheta_U = 55\text{ °C} - 25\text{ °C} = 30\text{ K}$
maximum permissible power dissipation of the installed equipment inclusive wiring ( $P_v$ ) in accordance with diagram:	enclosure size 3 (450 x 300 x 170 mm)
assembled enclosures:	$P_v = 45\text{ W}$

**Example: calculation of the operating temperature inside the enclosure ( $\vartheta_i$ )**

ambient temperature of the enclosure(s) ( $\vartheta_U$ ):	25 °C
rated power dissipation of the installed electrical equipment ( $P_v$ ):	30 W
heating up inside the enclosures in accordance with diagram over:	$\Delta\vartheta$
enclosure size 3 (450 x 300 x 170 mm) assembled enclosures:	$\Delta\vartheta = 17\text{ K}; \vartheta_i = \vartheta_U + \Delta\vartheta = 25\text{ °C} + 17\text{ K} = 42\text{ °C}$

$P_v$  = Power dissipation loss

**Assembly of Mi distribution boards according to assembly draft**

Pre-assembled and tested enclosures with electrical functions



**Knock out of box walls for electrical connection and cable entry**

Box walls are knocked out for the electrical connection within the distribution board.

For the assembly of the enclosures, the appropriate openings of the wedge joints are knocked out as well.



**Assembly of boxes**

For sealing the boxes in position, a self-adhesive wall gasket is stuck to the box wall (applies to closed box walls, too.)

The box assembly is carried out by a wedge connection.

To increase stability, press wall clamps onto the box fins.

Use a wall separator for subdividing 300 mm box walls into two 150 mm walls for flange or box mounting.



**Mi Distribution Boards**

**Technical details**  
**Flanges, cable entries**

**Flanges**

Attach flanges by means of 4 wedge links and 1 clamp to the box wall.



**Cable entry**

Knock out the appropriate cable entries within flanges or box walls with screwdriver.

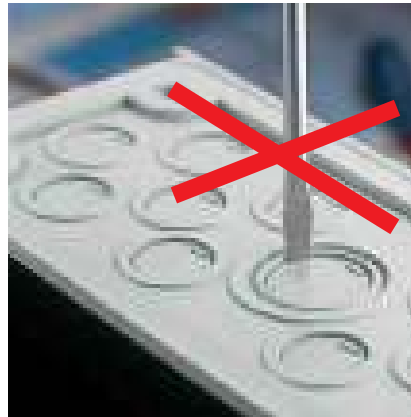

**Cable glands**

Insert cable gland into the appropriate knockout and fasten with lock nut.



**Assembly of cable insertion**

Knock out the respective box wall and saw out the upper box fin next to the wedge fastening.

Screw mount the cable insertion and insert the rubber entries.



Adjust stepped grommet on the cable diameter.

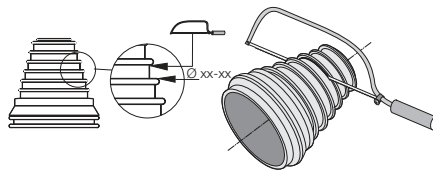

Insert cable and fix it with cable ties.

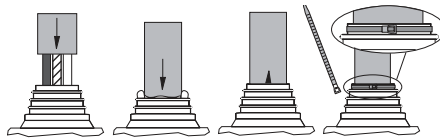

Insert the cable into the box from the front.



**Installation of extension frame**

Fix attachments for extension frame in base of enclosure.

Right:  
Place extension frame on base of enclosure.



Fix extension frame with screws onto base of enclosure.



**Device installation on mounting plates or DIN rails**

Fasten installation devices on mounting plates with self-threading screws.

Screw mounting plate onto base of box.



Mount DIN rails directly onto base of boxes or on spacers Mi DS .. in heights of 25 or 50 mm.



**Installation of equipment in cover plates**

Pre-drill the sections at the corners and saw out with piercing saw. Use saw blades with rough teeth for plastics.

Screw support for the protection cover Mi EP .. onto base of box.

Attach protection cover.

Close unused equipment openings in protection covers with attached blanking strips.



**Device installation in circuit breaker boxes**

Circuit breaker boxes can be fitted with any DIN rail equipment, if per row (12 modules 12x18 mm) the assigned backup fuse won't exceed 80 A.



PE and N terminals for copper conductors (installed)

Note to Mi Circuit breaker boxes:  
Spare equipment openings in protection covers are to be covered with blanking strips to prevent accidental contact (blanking strips are enclosed for 50 % of equipment openings)

Dimension of 1 module:  
1 Module = 18 mm

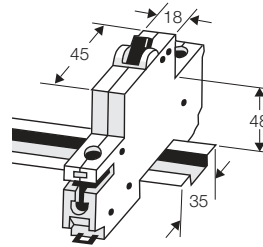

Dimensions according to DIN 43880 for DIN rail mounted device

**Protection covers**

Cover unused equipment openings with blanking strips to prevent accidental contact.



Provide for total protection against access to hazardous parts for accessible devices and busbar-mounted equipment.

Protection class II,   
(Total insulation)

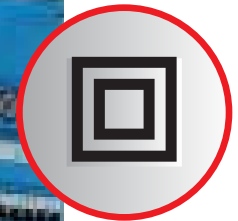

**Mi Distribution Boards**

**Technical details**

**Wall mounting, floor standing**

**Wall mounting**

directly through the base of the box

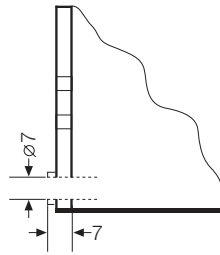

**External brackets**

for external box fixing

**Mi AL 40** (4 brackets)

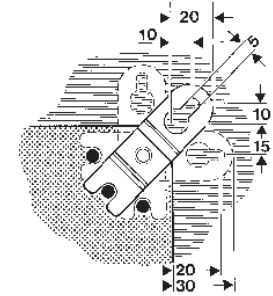
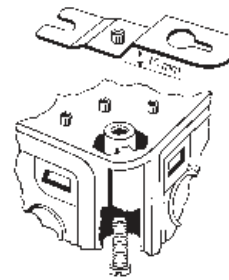

**Mounting profile**

for wall-mounted installation of Mi-Distribution boards, steel profile, 1950 mm long, dividable in the grid of 150 mm.

**Mi MS 2**



**Note:**

Please fix mounting profile in vertical position to enable a cable routing behind the assembly.

For cutting the required profile length fix mounting profile eg with a clamp to a desk.

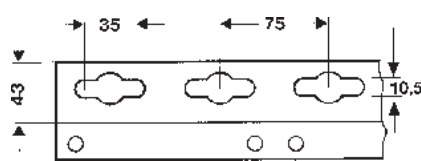

Fixing matrix of mounting profile

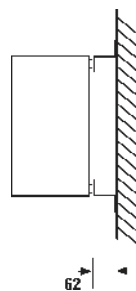

**Transport**

Regarding transportation its recommendable to protect the assembly against deflection. For that please screw the assembly to a solid timber.



ENYFLEX

Empty enclosures  
IEC 62208

## Empty enclosures in accordance with IEC 62208

- for customized solutions and individual applications
- for example for low-voltage switchgear and controlgear assemblies in accordance with the IEC 61439-series
- degree of protection IP 55-IP 65
- made from thermoplastics
- protection class II, 

General information	376 - 377
Empty enclosures type KG, cable entry via metric knockouts	378 - 382
Empty enclosures type K, box walls without knockouts, can be drilled individually	383 - 386
Accessories	387 - 392
Technical details	393 - 397

Further technical information can be found on the Internet  
[www.hensel-electric.de](http://www.hensel-electric.de) -> Products

**IEC 62208**

Enclosures for low-voltage switchgear and controlgear assemblies.  
General requirements

**General information**

The IEC 62208 standard applies to empty enclosures, prior to the incorporation of switchgear and controlgear components by the user, as supplied by the enclosure manufacturer.

It specifies general definitions, classifications, characteristics and test requirements of enclosures to be used as part of switchgear and controlgear assemblies (e.g. in accordance with the IEC 61439-series).



**Protection against electric shock**

In order to protect individuals in the event of faults against electric shock and the accompanying risks, enclosures are classified with protection class I (electrical earth) and protection class II (protection by total or reinforced insulation) according to IEC 61439, section 8.4.4. HENSEL empty enclosures are manufactured from insulating material and provide protection against electric shock according to protection class II.

**IP-Codes for protecting electrical equipment against dust and water**

Electrical equipment must be protected from external influences and conditions for safety reasons. The two-digit IP-Codes indicate to what extent the enclosure provides protection against hazardous parts and ingress of dust (1st digit) or water (2nd digit). For example IP 65: Electrical equipment inside the enclosure is protected against dust and harmful water and humidity.

Therefore the IP-Codes indicate the suitability of enclosures for different environmental conditions.

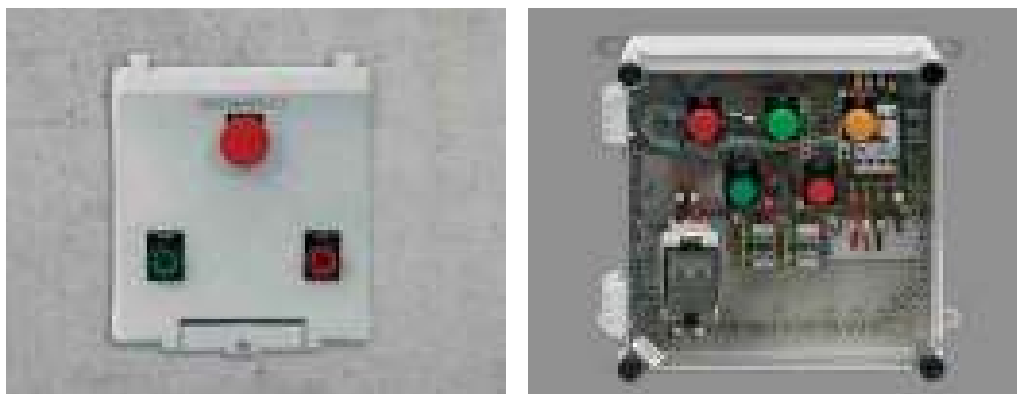

**Effects on the degree of protection (IP-Code) when devices are built in the lid**

If any switches, displays, push buttons or other equipment are built into the lid of an enclosure, the manufacturer must consider the effects on the degree of protection at that specific point.

The installation of electrical equipment into the lid, door or wall of an enclosure can reduce the degree of protection of the enclosure in that specific installation area depending on the degree of protection of the equipment and depending on additional measures for sealing the point of entry.

Example: The installation of an IP 44 socket into the lid of an IP 65 enclosure reduces the degree of protection in that specific area to IP 44. The enclosure itself still provides IP 65, but the manufacturer has to draw attention to the fact, that the socket only provides IP 44 for the area where it is installed.

**Operating and ambient conditions**

Empty enclosures according to IEC 62208 are applicable in ambient temperatures from -25 °C to +40 °C (outdoor installation) or from -5 °C to +40 °C (indoor installation).

The IEC 62208 requires the specification of the power dissipation capability  $P_{de}$  of the enclosures

**Temperature rise in enclosures and power dissipation**

In relationship with the outside temperatures the temperature rise inside of enclosures, caused by the flowing current and the power loss  $P_D$  of the installed electrical equipment, has to be considered.

Most devices are designed for maximum ambient temperatures of +40 °C to +55 °C. Accordingly there may only be a narrow range for the temperature rise inside of the enclosure if the ambient temperature is close to the maximum operating temperature of the installed equipment.

The enclosure with its power dissipation capability  $P_{de}$  has to be able to dissipate the power loss  $P_D$  of the installed electrical equipment inside of the enclosure without exceeding the limits of operating and ambient temperatures.

This ensures that the inside of an enclosure is not heated inadmissibly at a defined installed power loss and guarantees the operative readiness and reliable performance of the built-in electrical equipment.

The power dissipation  $P_D$  of the electrical equipment is given in the technical data of the respective manufacturers. The power dissipation capability  $P_{de}$  of Hensel empty enclosures are given in the technical data of this catalogue.

**A possible application for the power dissipation capability is the verification of temperature rise in accordance with IEC 61439-1, section 10.10.**

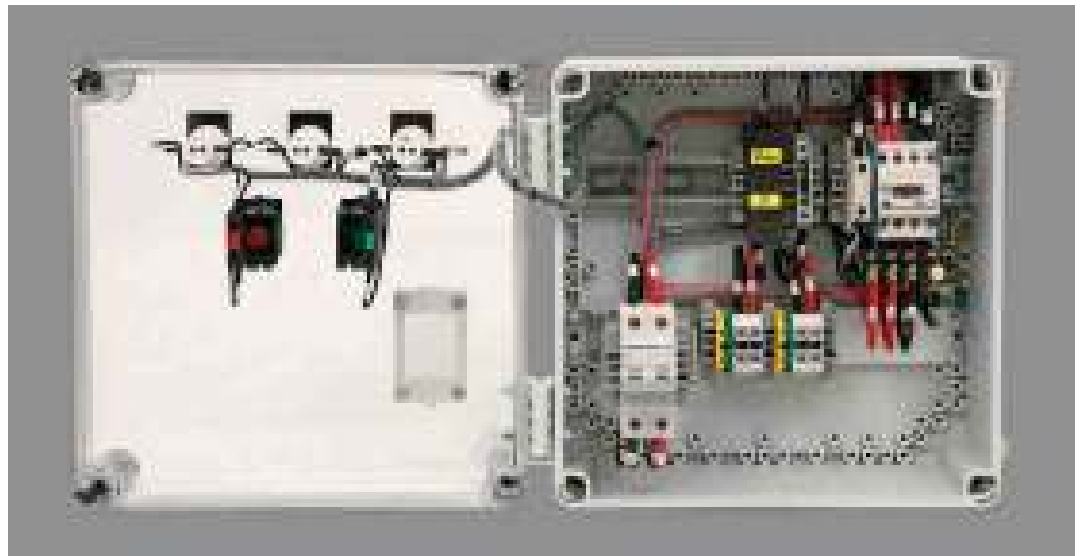

The temperature inside of enclosures rises by the flowing current and the power loss of the installed electrical equipment.

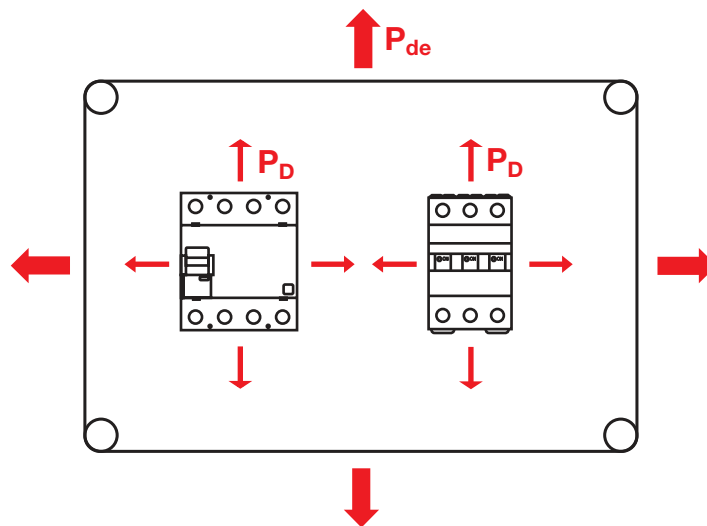

The enclosure with its power dissipation capability  $P_{de}$  has to be able to dissipate the power loss  $P_D$  of the installed electrical equipment inside of the enclosure without exceeding the limits of operating and ambient temperatures.

$P_{de}$  = power dissipation capability  
 $P_D$  = power dissipation

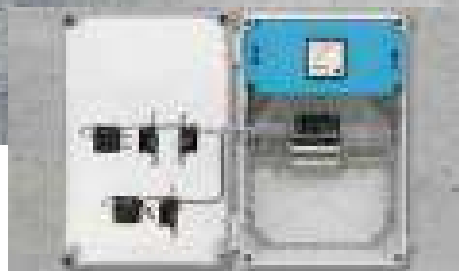

### Empty enclosures in accordance with IEC 62208

**For customized solutions and individual applications  
Compliance with the safety requirements of the applicable product  
standard (e.g. IEC 61439-series) is the responsibility of the assembly  
manufacturer and not of the enclosure manufacturer.**

- For example for low-voltage switchgear and controlgear assemblies in accordance with IEC 61439-series
- For the installation of devices that must be operated externally, such as plug devices, push buttons and switches
- Installation of electrical equipment via DIN rails or mounting plates
- Cable entry via metric knockouts respectively by drilling individually using ESM grommets or AKM cable glands, see index cable entry systems
- Fasteners for tool operation as standard
- Screws made of stainless steel V2A
- Hinges for lids available for operating installation devices within a large area
- Material: PS polystyrene or PC polycarbonate
- Burning behaviour: Glow wire test in accordance with IEC 60695-2-11: 750 °C / 960 °C, flame-retardant, self-extinguishing
- Empty enclosures are equipment with protection class II,  in accordance with IEC 61439-1, section 8.4.4
- Degree of protection: IP 55, IP 65 with cable glands
- Colour: grey, RAL 7035



**KG 9001**

**Built-in dimensions W 101 x H 205 x D 95 mm**

- degree of protection: IP 55 (ESM), IP 65 (see index cable entry systems)
- for installation equipment on DIN rails or mounting plates (order separately)
- max. installation depth with built-in mounting plate 95 mm, with built-in DIN rail 89 mm
- with transparent hinged lid
- fastener for tool operation
- sealable
- cable entry via metric knockouts
- included cable entry:  
 2 ESM 25, sealing range Ø 9-17 mm and  
 1 ESM 32, sealing range Ø 9-23 mm

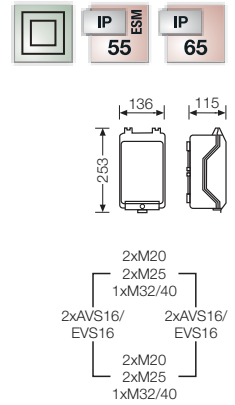

rated insulation voltage	$U_i = 1000 \text{ V a.c.}$
impact strength	IK 08 (5 Joule)
static load	mounting plate or DIN rail = 1.3 kg lid = 1.2 kg
power dissipation capability at $\Delta\theta = 40 \text{ K}$	$P_{de} = 16.5 \text{ watts}$
relative power dissipation capability in watts per K	$P_{de} = 0.4125 \text{ watts per K}$



**KG 9002**

**Built-in dimensions W 133 x H 205 x D 95 mm**

- degree of protection: IP 55 (ESM), IP 65 (see index cable entry systems)
- for installation equipment on DIN rails or mounting plates (order separately)
- max. installation depth with built-in mounting plate 95 mm, with built-in DIN rail 89 mm
- please order DIN rails or mounting plates additionally
- with transparent hinged lid
- fastener for tool operation
- sealable
- cable entry via metric knockouts
- included cable entry:  
 2 ESM 25, sealing range Ø 9-17 mm and  
 1 ESM 32, sealing range Ø 9-23 mm

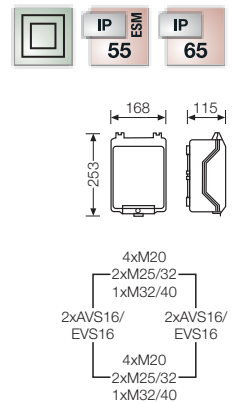

rated insulation voltage	$U_i = 1000 \text{ V a.c.}$
impact strength	IK 08 (5 Joule)
static load	mounting plate or DIN rail = 1.6 kg lid = 1.2 kg
power dissipation capability at $\Delta\theta = 40 \text{ K}$	$P_{de} = 16.8 \text{ watts}$
relative power dissipation capability in watts per K	$P_{de} = 0.42 \text{ watts per K}$

Application:



KG empty enclosures with transparent lid

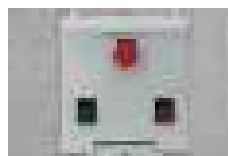

KG empty enclosures with opaque lid



**KG 9003**

**Built-in dimensions W 182 x H 205 x D 95 mm**

- degree of protection: IP 55 (ESM), IP 65 (see index cable entry systems)
- for installation equipment on DIN rails or mounting plates (order separately)
- max. installation depth with built-in mounting plate 95 mm, with built-in DIN rail 89 mm
- please order DIN rails or mounting plates additionally
- with transparent hinged lid
- fastener for tool operation
- sealable
- cable entry via metric knockouts
- included cable entry:  
 2 ESM 25, sealing range Ø 9-17 mm and  
 1 ESM 32, sealing range Ø 9-23 mm

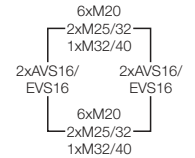
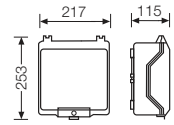

rated insulation voltage	$U_i = 1000 \text{ V a.c.}$
impact strength	IK 08 (5 Joule)
static load	mounting plate or DIN rail = 1.6 kg lid = 1.6 kg
power dissipation capability at $\Delta\theta = 40 \text{ K}$	$P_{de} = 17.6 \text{ watts}$
relative power dissipation capability in watts per K	$P_{de} = 0.44 \text{ watts per K}$

Application



Application

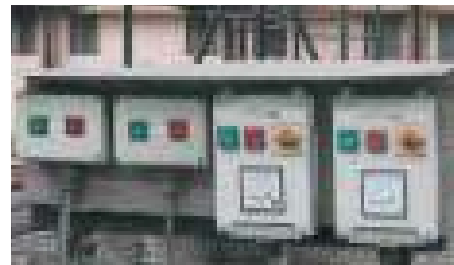



**KG 9001 IN**

**Built-in dimensions W 101 x H 205 x D 95 mm**

- degree of protection: IP 55 (ESM), IP 65 (see index cable entry systems)
- for installation equipment on DIN rails or mounting plates (order separately)
- max. installation depth with built-in mounting plate 95 mm, with built-in DIN rail 89 mm
- with opaque hinged lid
- fastener for tool operation
- sealable
- cable entry via metric knockouts
- included cable entry:  
 2 ESM 25, sealing range Ø 9-17 mm and  
 1 ESM 32, sealing range Ø 9-23 mm

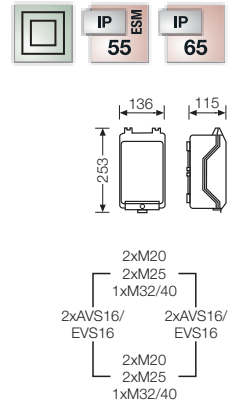

rated insulation voltage	$U_i = 1000 \text{ V a.c.}$
impact strength	IK 08 (5 Joule)
static load	mounting plate or DIN rail = 1.3 kg lid = 1.2 kg
power dissipation capability at $\Delta\theta = 40 \text{ K}$	$P_{de} = 16.5 \text{ watts}$
relative power dissipation capability in watts per K	$P_{de} = 0.4125 \text{ watts per K}$



**KG 9002 IN**

**Built-in dimensions W 133 x H 205 x D 95 mm**

- degree of protection: IP 55 (ESM), IP 65 (see index cable entry systems)
- for installation equipment on DIN rails or mounting plates (order separately)
- max. installation depth with built-in mounting plate 95 mm, with built-in DIN rail 89 mm
- with opaque hinged lid
- fastener for tool operation
- sealable
- cable entry via metric knockouts
- included cable entry:  
 2 ESM 25, sealing range Ø 9-17 mm and  
 1 ESM 32, sealing range Ø 9-23 mm

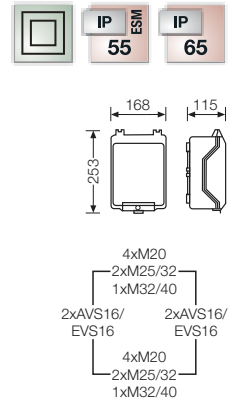

rated insulation voltage	$U_i = 1000 \text{ V a.c.}$
impact strength	IK 08 (5 Joule)
static load	mounting plate or DIN rail = 1.6 kg lid = 1.2 kg
power dissipation capability at $\Delta\theta = 40 \text{ K}$	$P_{de} = 16.8 \text{ watts}$
relative power dissipation capability in watts per K	$P_{de} = 0.42 \text{ watts per K}$

Application:



KG empty enclosures with transparent lid

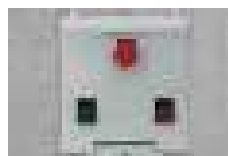

KG empty enclosures with opaque lid



**KG 9003 IN**

**Built-in dimensions W 182 x H 205 x D 95 mm**

- degree of protection: IP 55 (ESM), IP 65 (see index cable entry systems)
- for installation equipment on DIN rails or mounting plates (order separately)
- max. installation depth with built-in mounting plate 95 mm, with built-in DIN rail 89 mm
- with opaque hinged lid
- fastener for tool operation
- sealable
- cable entry via metric knockouts
- included cable entry:  
 2 ESM 25, sealing range Ø 9-17 mm and  
 1 ESM 32, sealing range Ø 9-23 mm

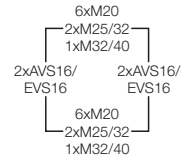
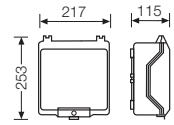

rated insulation voltage	$U_i = 1000 \text{ V a.c.}$
impact strength	IK 08 (5 Joule)
static load	mounting plate or DIN rail = 1.6 kg lid = 1.6 kg
power dissipation capability at $\Delta\theta = 40 \text{ K}$	$P_{de} = 17.6 \text{ watts}$
relative power dissipation capability in watts per K	$P_{de} = 0.44 \text{ watts per K}$

Application



Application

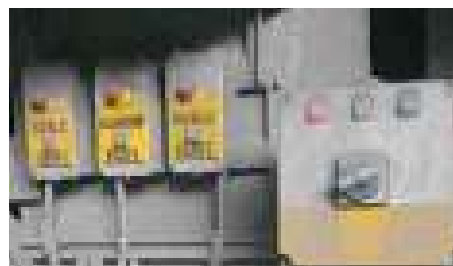



**K 0100**

**Built-in dimensions W 275 x H 125 x D 150 mm**

- enclosure size 1, type Mi
- for installation equipment on DIN rails or mounting plates (order separately)
- max. installation depth with built-in mounting plate 146 mm, with built-in DIN rail 135 mm
- with transparent lid
- lid fasteners for tool operation
- sealable
- box walls without knockouts
- optional hinges for device installation in the lid
- external brackets for wall fixing as accessories

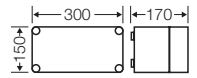

rated insulation voltage	$U_i = 690 \text{ V a.c.} / 1000 \text{ V d.c.}$
impact strength	IK 08 (5 Joule)
static load	mounting plate or DIN rail = 3.2 kg lid = 1.3 kg
power dissipation capability at $\Delta\theta = 40 \text{ K}$	$P_{de} = 33 \text{ watts}$
relative power dissipation capability in watts per K	$P_{de} = 0.825 \text{ watts per K}$

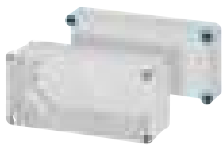

**K 0101**

**Built-in dimensions W 275 x H 125 x D 150 mm**

- enclosure size 1, type Mi
- for installation equipment on DIN rails or mounting plates (order separately)
- max. installation depth with built-in mounting plate 146 mm, with built-in DIN rail 135 mm
- with opaque lid
- lid fasteners for tool operation
- sealable
- box walls without knockouts
- optional hinges for device installation in the lid
- external brackets for wall fixing as accessories

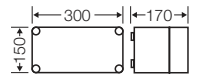

rated insulation voltage	$U_i = 690 \text{ V a.c.} / 1000 \text{ V d.c.}$
impact strength	IK 08 (5 Joule)
static load	mounting plate or DIN rail = 3.2 kg lid = 1.3 kg
power dissipation capability at $\Delta\theta = 40 \text{ K}$	$P_{de} = 33 \text{ watts}$
relative power dissipation capability in watts per K	$P_{de} = 0.825 \text{ watts per K}$

Application:



Empty enclosures with installed equipment on DIN rail and mounting plate



DIN rails for equipment or terminals with clip-on mounting

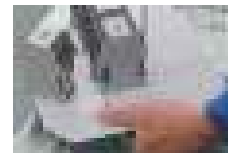

Mounting plates



**K 0200**

**Built-in dimensions W 275 x H 275 x D 150 mm**

- enclosure size 2, type Mi
- for installation equipment on DIN rails or mounting plates (order separately)
- max. installation depth with built-in mounting plate 146 mm, with built-in DIN rail 135 mm
- with transparent lid
- lid fasteners for tool operation
- sealable
- box walls without knockouts
- optional hinges for device installation in the lid
- external brackets for wall fixing as accessories

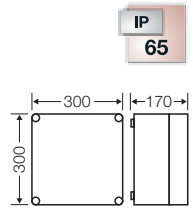

rated insulation voltage	$U_i = 690 \text{ V a.c.} / 1000 \text{ V d.c.}$
impact strength	IK 08 (5 Joule)
static load	mounting plate or DIN rail = 6.5 kg lid = 1.6 kg
power dissipation capability at $\Delta\theta = 40 \text{ K}$	$P_{de} = 53 \text{ watts}$
relative power dissipation capability in watts per K	$P_{de} = 1.325 \text{ watts per K}$



**K 0201**

**Built-in dimensions W 275 x H 275 x D 150 mm**

- enclosure size 2, type Mi
- for installation equipment on DIN rails or mounting plates (order separately)
- max. installation depth with built-in mounting plate 146 mm, with built-in DIN rail 135 mm
- with opaque lid
- lid fasteners for tool operation
- sealable
- box walls without knockouts
- optional hinges for device installation in the lid
- external brackets for wall fixing as accessories

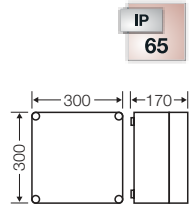

rated insulation voltage	$U_i = 690 \text{ V a.c.} / 1000 \text{ V d.c.}$
impact strength	IK 08 (5 Joule)
static load	mounting plate or DIN rail = 6.5 kg lid = 1.6 kg
power dissipation capability at $\Delta\theta = 40 \text{ K}$	$P_{de} = 53 \text{ watts}$
relative power dissipation capability in watts per K	$P_{de} = 1.325 \text{ watts per K}$

DIN rails for equipment or terminals with clip-on mounting

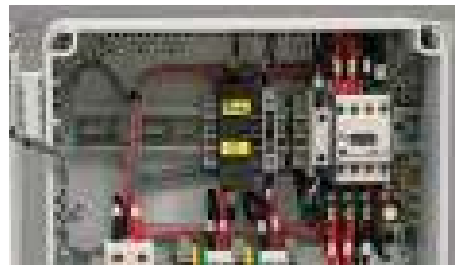

Mounting plates for equipment

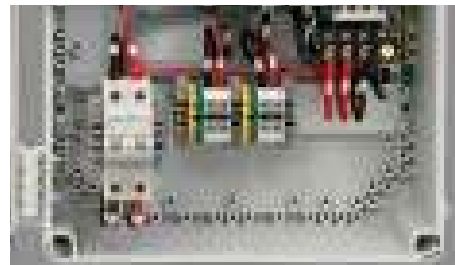

**Empty enclosures in accordance with IEC 62208 for customized solutions and individual applications box walls without knockouts**



**K 0300**

**Built-in dimensions W 275 x H 425 x D 150 mm**

- enclosure size 3, type Mi
- for installation equipment on DIN rails or mounting plates (order separately)
- max. installation depth with built-in mounting plate 146 mm, with built-in DIN rail 135 mm
- with transparent lid
- lid fasteners for tool operation
- sealable
- box walls without knockouts
- optional hinges for device installation in the lid
- external brackets for wall fixing as accessories

IP  
65

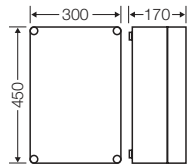

rated insulation voltage	$U_i = 690 \text{ V a.c.} / 1000 \text{ V d.c.}$
impact strength	IK 08 (5 Joule)
static load	mounting plate or DIN rail = 9.2 kg lid = 3.2 kg
power dissipation capability at $\Delta\theta = 40 \text{ K}$	$P_{de} = 71 \text{ watts}$
relative power dissipation capability in watts per K	$P_{de} = 1.775 \text{ watts per K}$



**K 0301**

**Built-in dimensions W 275 x H 425 x D 150 mm**

- enclosure size 3, type Mi
- for installation equipment on DIN rails or mounting plates (order separately)
- max. installation depth with built-in mounting plate 146 mm, with built-in DIN rail 135 mm
- with opaque lid
- lid fasteners for tool operation
- sealable
- box walls without knockouts
- optional hinges for device installation in the lid
- external brackets for wall fixing as accessories

IP  
65

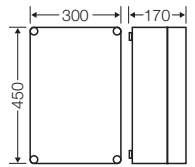

rated insulation voltage	$U_i = 690 \text{ V a.c.} / 1000 \text{ V d.c.}$
impact strength	IK 08 (5 Joule)
static load	mounting plate or DIN rail = 9.2 kg lid = 3.2 kg
power dissipation capability at $\Delta\theta = 40 \text{ K}$	$P_{de} = 71 \text{ watts}$
relative power dissipation capability in watts per K	$P_{de} = 1.775 \text{ watts per K}$

Application:



Empty enclosures with installed equipment on DIN rail and mounting plate



DIN rails for equipment or terminals with clip-on mounting

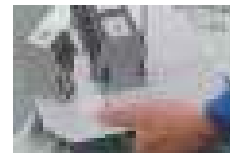

Mounting plates

**Empty enclosures in accordance with IEC 62208 for customized solutions and individual applications box walls without knockouts**



**K 0400**

**Built-in dimensions W 275 x H 575 x D 150 mm**

- enclosure size 4, type Mi
- for installation equipment on DIN rails or mounting plates (order separately)
- max. installation depth with built-in mounting plate 146 mm, with built-in DIN rail 135 mm
- with transparent lid
- lid fasteners for tool operation
- sealable
- box walls without knockouts
- optional hinges for device installation in the lid
- external brackets for wall fixing as accessories

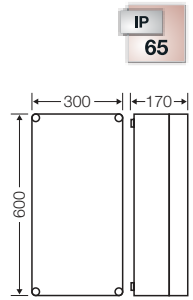

rated insulation voltage	$U_i = 690 \text{ V a.c.} / 1000 \text{ V d.c.}$
impact strength	IK 08 (5 Joule)
static load	mounting plate or DIN rail = 9.2 kg lid = 3.2 kg
power dissipation capability at $\Delta\theta = 40 \text{ K}$	$P_{de} = 93 \text{ watts}$
relative power dissipation capability in watts per K	$P_{de} = 2,325 \text{ watts per K}$



**K 0401**

**Built-in dimensions W 275 x H 575 x D 150 mm**

- enclosure size 4, type Mi
- for installation equipment on DIN rails or mounting plates (order separately)
- max. installation depth with built-in mounting plate 146 mm, with built-in DIN rail 135 mm
- with opaque lid
- lid fasteners for tool operation
- sealable
- box walls without knockouts
- optional hinges for device installation in the lid
- external brackets for wall fixing as accessories

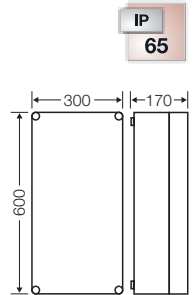

rated insulation voltage	$U_i = 690 \text{ V a.c.} / 1000 \text{ V d.c.}$
impact strength	IK 08 (5 Joule)
static load	mounting plate or DIN rail = 9.2 kg lid = 3.2 kg
power dissipation capability at $\Delta\theta = 40 \text{ K}$	$P_{de} = 93 \text{ watts}$
relative power dissipation capability in watts per K	$P_{de} = 2,325 \text{ watts per K}$

DIN rails for equipment or terminals with clip-on mounting

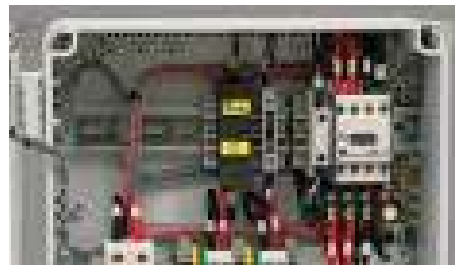

Mounting plates for equipment

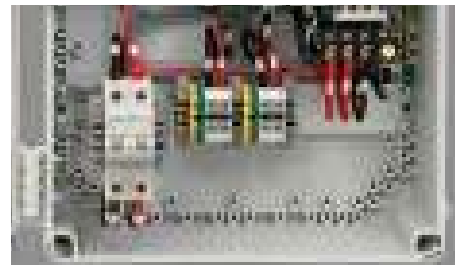



## Empty enclosures in accordance with IEC 62208

### Accessories

KG empty enclosures: DIN rails, mounting plates, PE/N terminals	388
K empty enclosures: DIN rails, mounting plates	389 - 390
Converting sets for lid operation or sealing	391
Locking device insertion, lid locks, triangle lid fastener, triangle key	391
Hinges for lids	392



**KG MP 01**

**Mounting plate for KG 9001**

- material laminated paper, coated
- material thickness 4 mm
- with fixing screws

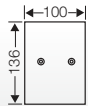

**KG MP 02**

**Mounting plate for KG 9002**

- material laminated paper, coated
- material thickness 4 mm
- with fixing screws

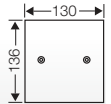

**KG MP 03**

**Mounting plate for KG 9003**

- material laminated paper, coated
- material thickness 4 mm
- with fixing screws

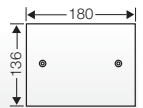

**KG TS 01**

**DIN rail for KG 9001**

- in accordance with DIN EN 60715
- for equipment or terminals with clip-on mounting
- with fixing screws

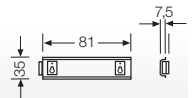

**KG TS 02**

**DIN rail for KG 9002**

- in accordance with DIN EN 60715
- for equipment or terminals with clip-on mounting
- with fixing screws

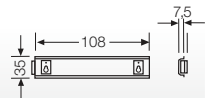

**KG TS 03**

**DIN rail for KG 9003**

- in accordance with DIN EN 60715
- for equipment or terminals with clip-on mounting
- with fixing screws

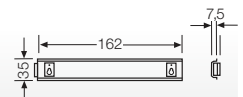

**KG PN 01**

**PE and N terminal**

- for KG 9001
- per PE/N number x cross section 3 x 25 mm<sup>2</sup>, 3 x 4 mm<sup>2</sup> Cu, screw-type terminal

rated insulation voltage U<sub>i</sub> = 400 V a.c.



**KG PN 02**

**PE and N terminal**

- for KG 9002
- PE+N x cross section 3 x 25 mm<sup>2</sup>, 5 x 4 mm<sup>2</sup> Cu, screw-type terminal

rated insulation voltage U<sub>i</sub> = 400 V a.c.



**KG PN 03**

**PE and N terminal**

- for KG 9003
- per PE/N number x cross section 4 x 25 mm<sup>2</sup>, 7 x 4 mm<sup>2</sup> Cu, screw-type terminal

rated insulation voltage U<sub>i</sub> = 400 V a.c.



**Mi TS 15**

**DIN rail**  
**length 134 mm**

- in accordance with DIN EN 60715
- for Mi-Empty boxes sizes 1, 6
- for equipment or terminals with clip-on mounting
- with fixing screws

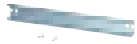
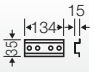

**Mi TS 30**

**DIN rail**  
**length 284 mm**

- in accordance with DIN EN 60715
- for Mi-Empty boxes sizes 1, 2, 3, 4, 6, 8
- for equipment or terminals with clip-on mounting
- with fixing screws



**Mi TS 45**

**DIN rail**  
**length 434 mm**

- in accordance with DIN EN 60715
- for Mi-Empty boxes sizes 3, 6
- for equipment or terminals with clip-on mounting
- with fixing screws



**Mi TS 60**

**DIN rail**  
**length 584 mm**

- in accordance with DIN EN 60715
- for Mi-Empty boxes sizes 4, 6, 8
- for equipment or terminals with clip-on mounting
- with fixing screws



Application:

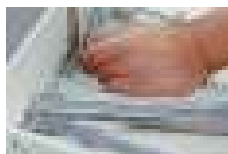

DIN rails for equipment or terminals with clip-on mounting



**Mi MP 1**

**Mounting plate**  
**W 259 x H 115 mm**

- material thickness 4 mm
- for Mi-Empty boxes sizes 1, 2, 3, 4, 6
- with fixing screws



**Mi MP 2**

**Mounting plate**  
**W 265 x H 265 mm**

- material thickness 4 mm
- for Mi-Empty boxes sizes 2, 3, 4, 6, 8
- with fixing screws

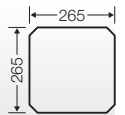

**Mi MP 3**

**Mounting plate**  
**W 265 x H 415 mm**

- material thickness 4 mm
- for Mi-Empty boxes sizes 3, 4, 6
- with fixing screws

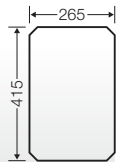

**Mi MP 4**

**Mounting plate**  
**W 265 x H 565 mm**

- material thickness 4 mm
- for Mi-Empty boxes sizes 4, 6, 8
- with fixing screws

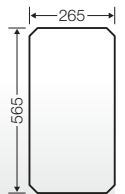

Application:

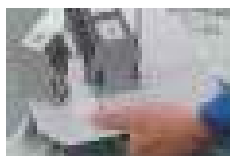

Mounting plates

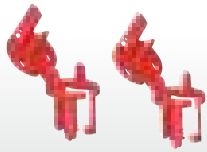

**Mi PL 2**

**Sealing cap**

- 2 sealing caps for converting the lid fasteners



**Mi SR 4**

**Conversion set for manual operation on tool operation**

- 4 fastening covers



**Mi SN 4**

**Conversion set for converting lid fasteners from tool to manual operation**

- 4 manual actuators



**Mi DV 01**

**Locking device insertion**

- only in connection with Mi PL 2, Mi SR 4 or Mi SN 4



**Mi ZS 11**

**Lid lock with locking device I for Mi boxes sizes 1 to 6**

- Is being used instead of fasteners for hand or tool operation in order to prevent unauthorised opening of the lids
- consisting of: cylinder lock, keys, locking device insertion, dust cover

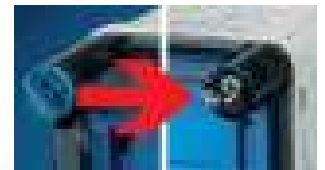

**Mi ZS 12**

**Lid lock with locking device II for Mi boxes sizes 1 to 6**

- Is being used instead of fasteners for hand or tool operation in order to prevent unauthorised opening of the lids
- consisting of: cylinder lock, keys, locking device insertion, dust cover

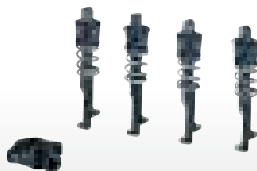
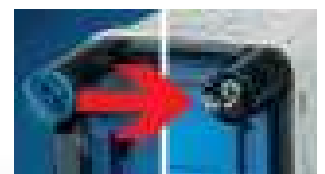

**Mi DR 04**

**Lid fastener for tool operation triangle 8 mm**

- is used instead of fasteners for hand- or tool operation, in order to make unauthorized opening of lids more difficult
- 4 locking devices with triangle 8 mm and key



**DS 1**

**Triangular key 8 mm**



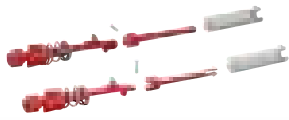

**Mi ZS 20**

**Mi hinge for lids  
for Mi boxes sizes 1, 2, 3, 4**

- For operating installation device within a large area. The lid keeps permanently connected to the box.
- When assembling several boxes, the insertion can only be carried out for the external boxes.



**Mi ZS 30**

**Hinge for lids**

- for empty boxes K 0xxx
- with lamellar plugs for 2 lid fixing tubes
- The lid keeps permanently connected to the box



**Mi ZS 40**

**Mi hinge for lids  
for Mi boxes sizes 1 to 8**

- For operating installation device within a large area. The lid keeps permanently connected to the box.
- Wall connectors or flanges are necessary for assembly
- Not applicable in boxes with covers



**Mi ZS 60**

**Mi hinge for lids  
for Mi boxes sizes 4 and 8 with extension frame**

- For operating installation device within a large area. The lid keeps permanently connected to the box.
- Wall connectors or flanges are necessary for assembly
- Not applicable in boxes with covers

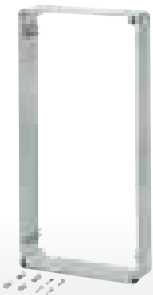

**Mi ZR 4**

**Extension frame  
for enclosure size 4**

- for extension of the installation depth by 85 mm
- degree of protection IP 65 is maintained with use of up to two extension frames
- inclusive fixing material

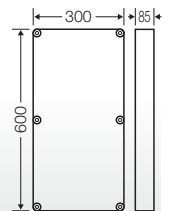

Application:



Mi hinges for lids enable to operate installation devices within a large area



## Empty enclosures in accordance with IEC 62208

### Technical details

Dimensions in mm	394 - 395
Power dissipation	396
Operating and ambient conditions	397

Technical details  
Dimensions in mm

Dimensions of the interior installation depth with installed mounting plates.

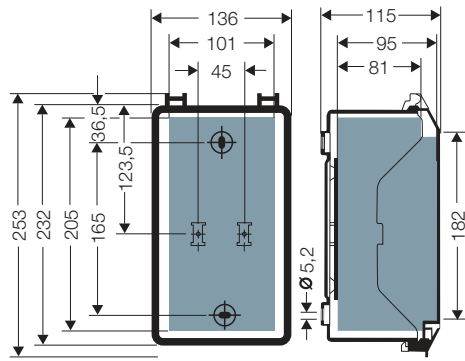

KG 9001  
KG 9001 IN

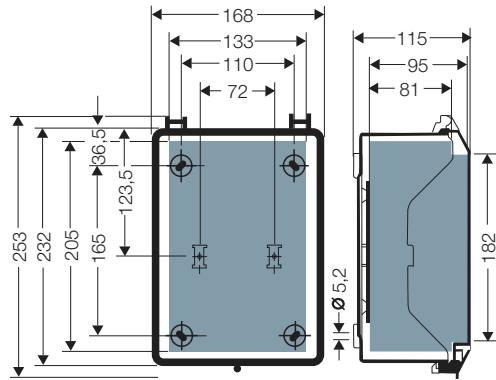

KG 9002  
KG 9002 IN

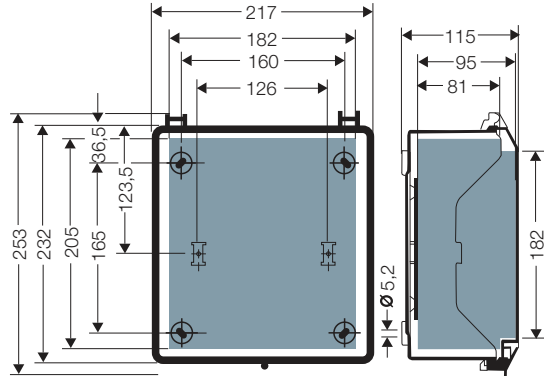

KG 9003  
KG 9003 IN

 = usable installation space with mounted cable glands

Technical details  
Dimensions in mm

Dimensions of the interior installation depth with installed mounting plates.

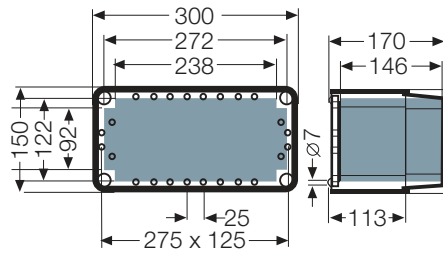

K 0100  
K 0101



K 0200  
K 0201

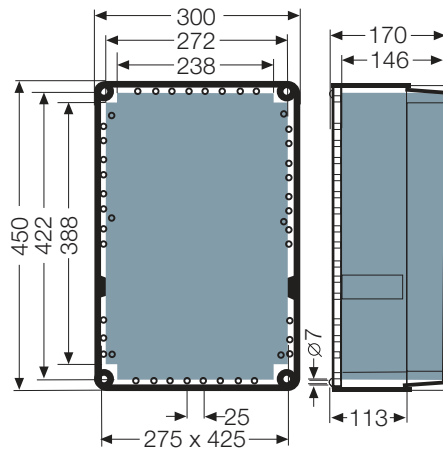

K 0300  
K 0301

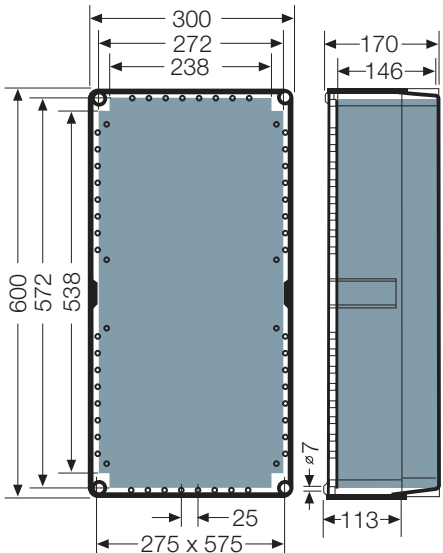

K 0400  
K 0401

 = usable installation space with mounted cable glands

KG empty enclosures: temperature rise ( $\Delta\theta$ ) by power dissipation of electrical devices

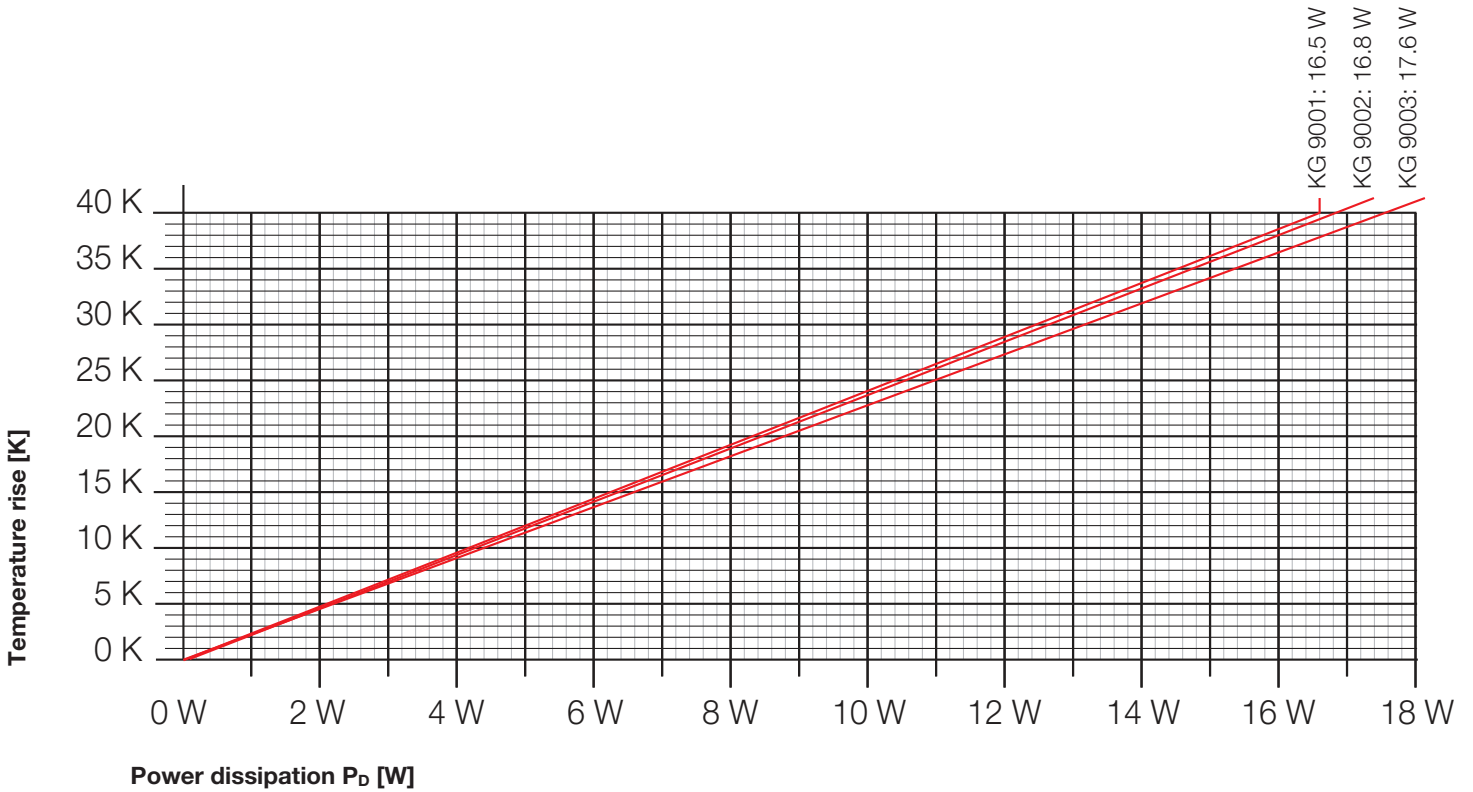

K empty enclosures: temperature rise ( $\Delta\theta$ ) by power dissipation of electrical devices

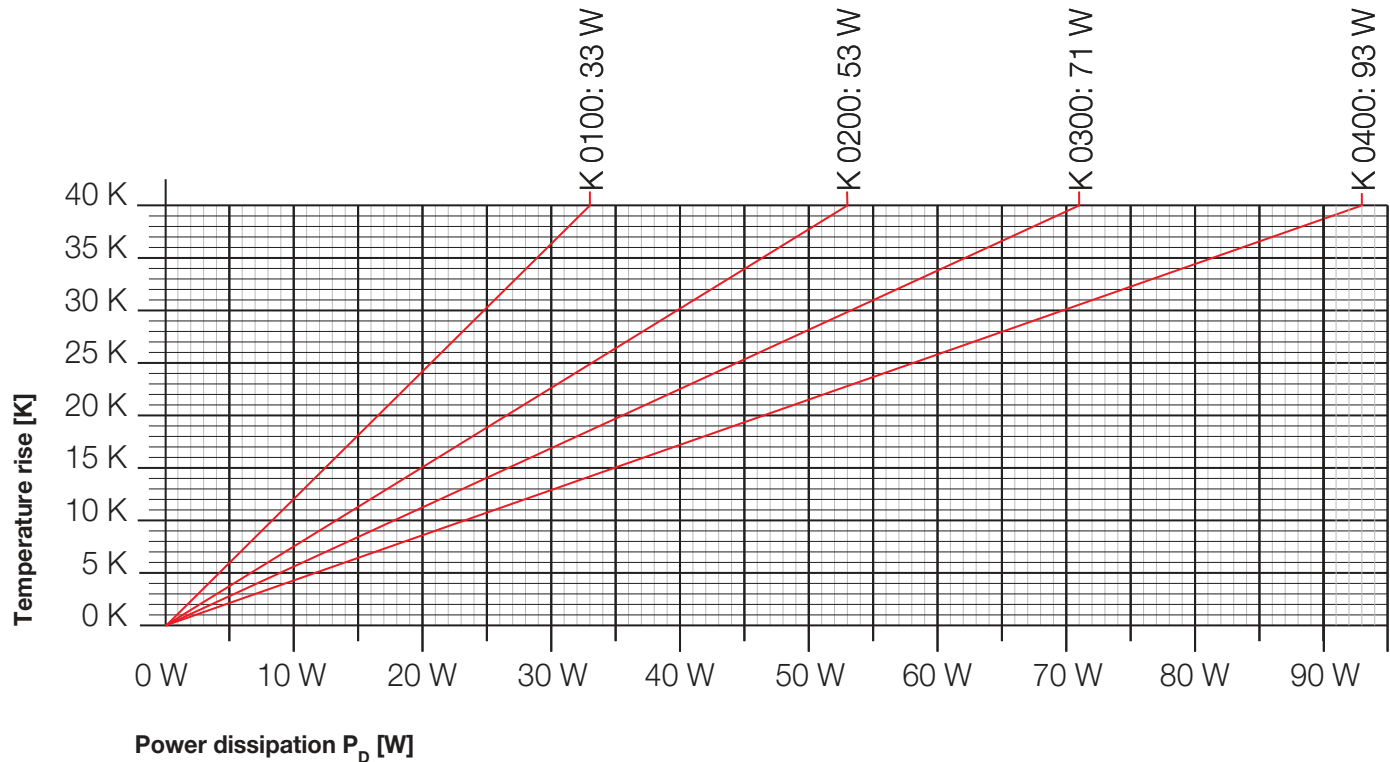

Power dissipation  $P_D$  [W]

Technical details  
Operating and ambient conditions

	Empty enclosures KG ....	Empty enclosures K ....
<b>Application area</b>	<b>Suitable for indoor installation and outdoor installation, protected against weather influences</b> However, pay attention to the climatic effects on the installed equipment , for example, high or low ambient temperatures or formation of condensed water see technical information	
<b>Ambient temperature</b>		
- Average value over 24 hours	+35 °C	+35 °C
- Maximum value	+40 °C	+40 °C
- Minimum value	-25 °C	-25 °C
<b>Relative humidity</b>		
- short-time	–	50% at 40 °C 100% at 25 °C
<b>Fire protection</b> in the event of internal faults	Demands placed on electrical devices from standards and laws:  Minimum requirements - Glow wire test in accordance with IEC 60695-2-11: - (650 ± 15) °C for boxes and cable glands	
<b>Burning behaviour</b>		
- Glow wire test IEC 60 695-2-11	750 °C	960 °C
- UL Subject 94	V-2 flame-retardant self-extinguishing	V-2 flame-retardant self-extinguishing
<b>Degree of protection against mechanical load</b>	IK 08 (5 Joule)	IK 08 (5 Joule)
<b>Toxic behaviour</b>	halogen-free <sup>1)</sup> silicone-free	halogen-free <sup>1)</sup> silicone-free
	<sup>1)</sup> “Halogen-free” in accordance with IEC 60754-2“ Common test methods for cables - Determination of the amount of halogen acid gas”.  <b>For material properties see Technical details.</b>	



Cable entry systems

## Cable entry systems

Grommets ESM, IP 54 for knockouts M 16 to M 40	400
Stepped grommets STM, IP 55 for knockouts M 16 to M 40	401
Grommets EDK , IP 65 for knockouts M 16 to M 40	402
Grommets EDR for conduits , IP 65 for knockouts M 16 to M 40	403
Cable glands AKM, IP 66/67 for knockouts M 12 to M 63	404 - 405
Cable glands ASS, IP 66/67 for knockouts M 12 to M 63	406 - 407
Combi climate glands, IP 66/67 for knockouts M 20 to M 40	408 - 412
Sealing plug VSB	413
Pressure compensation element	414
Stepped grommet, flange, cable retention	415
Outside diameter of conventional cable cross sections, assignment of cable outside diameters to cable entries	416
Cable glands AKS, IP 65 for knockouts Pg 9 to Pg 48	417 - 418
Technical Details	419 - 421

Further technical information can be found on the Internet  
[www.hensel-electric.de](http://www.hensel-electric.de) -> Products



**ESM 16**  
**Grommets**  
**for knockouts M 16**

- sealing range: Ø 4.8-11 mm
- bore-hole: Ø 16.5 mm
- wall thickness 1.5-3.5 mm
- for indoor - normal environment and (or) protected outdoor installation
- ambient temperature - 25 °C to + 35 °C
- glow wire test IEC 60695-2-11: 750 °C
- Colour: grey, RAL 7035



**ESM 20**  
**Grommets**  
**for knockouts M 20**

- sealing range: Ø 6-13 mm
- bore-hole: Ø 20.5 mm
- wall thickness 1.5-3.5 mm
- for indoor - normal environment and (or) protected outdoor installation
- ambient temperature - 25 °C to + 35 °C
- glow wire test IEC 60695-2-11: 750 °C
- Colour: grey, RAL 7035

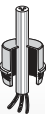

**ESM 25**  
**Grommets**  
**for knockouts M 25**

- sealing range: Ø 9-17 mm
- bore-hole: Ø 25.5 mm
- wall thickness 1.5-3.5 mm
- for indoor - normal environment and (or) protected outdoor installation
- ambient temperature - 25 °C to + 35 °C
- glow wire test IEC 60695-2-11: 750 °C
- Colour: grey, RAL 7035



**ESM 32**  
**Grommets**  
**for knockouts M 32**

- sealing range: Ø 9-23 mm
- bore-hole: Ø 32.5 mm
- wall thickness 1.5-3.5 mm
- for indoor - normal environment and (or) protected outdoor installation
- ambient temperature - 25 °C to + 35 °C
- glow wire test IEC 60695-2-11: 750 °C
- Colour: grey, RAL 7035



**ESM 40**  
**Grommets**  
**for knockouts M 40**

- sealing range: Ø 17-30 mm
- bore-hole: Ø 40.5 mm
- wall thickness 1.5-3.5 mm
- for indoor - normal environment and (or) protected outdoor installation
- ambient temperature - 25 °C to + 35 °C
- glow wire test IEC 60695-2-11: 750 °C
- Colour: grey, RAL 7035





**STM 16**  
**Stepped grommet**  
**for knockouts M 16**

- sealing range: Ø 3.5-12 mm
- bore-hole: Ø 16.5 mm
- wall thickness 1.5-4 mm
- for indoor - normal environment and (or) protected outdoor installation
- ambient temperature - 25 °C to + 35 °C
- glow wire test IEC 60695-2-11: 750 °C
- Colour: grey, RAL 7035



**STM 20**  
**Stepped grommet**  
**for knockouts M 20**

- sealing range: Ø 5-16 mm
- bore-hole: Ø 20.5 mm
- wall thickness 1.5-4 mm
- for indoor - normal environment and (or) protected outdoor installation
- ambient temperature - 25 °C to + 35 °C
- glow wire test IEC 60695-2-11: 750 °C
- Colour: grey, RAL 7035

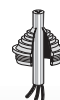

**STM 25**  
**Stepped grommet**  
**for knockouts M 25**

- sealing range: Ø 5-21 mm
- bore-hole: Ø 25.5 mm
- wall thickness 1.5-4 mm
- for indoor - normal environment and (or) protected outdoor installation
- ambient temperature - 25 °C to + 35 °C
- glow wire test IEC 60695-2-11: 750 °C
- Colour: grey, RAL 7035

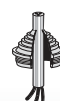

**STM 32**  
**Stepped grommet**  
**for knockouts M 32**

- sealing range: Ø 13-26.5 mm
- bore-hole: Ø 32.5 mm
- wall thickness 1.5-4 mm
- for indoor - normal environment and (or) protected outdoor installation
- ambient temperature - 25 °C to + 35 °C
- glow wire test IEC 60695-2-11: 750 °C
- Colour: grey, RAL 7035

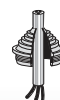

**STM 40**  
**Stepped grommet**  
**for knockouts M 40**

- sealing range: Ø 13-34 mm
- bore-hole: Ø 40.5 mm
- wall thickness 1.5-4 mm
- for indoor - normal environment and (or) protected outdoor installation
- ambient temperature - 25 °C to + 35 °C
- glow wire test IEC 60695-2-11: 750 °C
- Colour: grey, RAL 7035

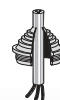



**EDK 16**  
**Grommets**  
**for knockouts M 16**



- sealing range: Ø 5-10 mm
- bore-hole: Ø 16.5 mm
- wall thickness 1.5-3.5 mm
- for indoor - normal environment and (or) protected outdoor installation
- ambient temperature - 25 °C to + 35 °C
- glow wire test IEC 60695-2-11: 750 °C
- Colour: grey, RAL 7035

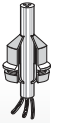

**EDK 20**  
**Grommets**  
**for knockouts M 20**



- sealing range: Ø 6-13 mm
- bore-hole: Ø 20.5 mm
- wall thickness 1.5-3.5 mm
- for indoor - normal environment and (or) protected outdoor installation
- ambient temperature - 25 °C to + 35 °C
- glow wire test IEC 60695-2-11: 750 °C
- Colour: grey, RAL 7035

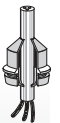

**EDK 25**  
**Grommets**  
**for knockouts M 25**



- sealing range: Ø 9-17 mm
- bore-hole: Ø 25.5 mm
- wall thickness 1.5-3.5 mm
- for indoor - normal environment and (or) protected outdoor installation
- ambient temperature - 25 °C to + 35 °C
- glow wire test IEC 60695-2-11: 750 °C
- Colour: grey, RAL 7035

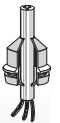

**EDK 32**  
**Grommets**  
**for knockouts M 32**



- sealing range: Ø 8-23 mm
- bore-hole: Ø 32.5 mm
- wall thickness 1.5-3.5 mm
- for indoor - normal environment and (or) protected outdoor installation
- ambient temperature - 25 °C to + 35 °C
- glow wire test IEC 60695-2-11: 750 °C
- Colour: grey, RAL 7035

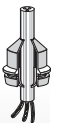

**EDK 40**  
**Grommets**  
**for knockouts M 40**



- sealing range: Ø 11-30 mm
- bore-hole: Ø 40.5 mm
- wall thickness 1.5-3.5 mm
- for indoor - normal environment and (or) protected outdoor installation
- ambient temperature - 25 °C to + 35 °C
- glow wire test IEC 60695-2-11: 750 °C
- Colour: grey, RAL 7035

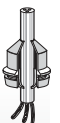



**EDR 16**  
**Grommets for conduits for knockouts M 16**

- conduit connection M 16
- bore-hole: Ø 16.5 mm
- wall thickness 1.5-3.2 mm
- for indoor - normal environment and (or) protected outdoor installation
- ambient temperature - 25 °C to + 35 °C
- glow wire test IEC 60695-2-11: 750 °C
- Colour: grey, RAL 7035



**EDR 20**  
**Grommets for conduits for knockouts M 20**

- conduit connection M 20
- bore-hole: Ø 20.5 mm
- wall thickness 1.5-3.2 mm
- for indoor - normal environment and (or) protected outdoor installation
- ambient temperature - 25 °C to + 35 °C
- glow wire test IEC 60695-2-11: 750 °C
- Colour: grey, RAL 7035



**EDR 25**  
**Grommets for conduits for knockouts M 25**

- conduit connection M 25
- bore-hole: Ø 25.5 mm
- wall thickness 1.5-3.2 mm
- for indoor - normal environment and (or) protected outdoor installation
- ambient temperature - 25 °C to + 35 °C
- glow wire test IEC 60695-2-11: 750 °C
- Colour: grey, RAL 7035



**EDR 32**  
**Grommets for conduits for knockouts M 32**

- conduit connection M 32
- bore-hole: Ø 32.5 mm
- wall thickness 1.5-3.2 mm
- for indoor - normal environment and (or) protected outdoor installation
- ambient temperature - 25 °C to + 35 °C
- glow wire test IEC 60695-2-11: 750 °C
- Colour: grey, RAL 7035



**EDR 40**  
**Grommets for conduits for knockouts M 40**

- conduit connection M 40
- bore-hole: Ø 40.5 mm
- wall thickness 1.5-3.2 mm
- for indoor - normal environment and (or) protected outdoor installation
- ambient temperature - 25 °C to + 35 °C
- glow wire test IEC 60695-2-11: 750 °C
- Colour: grey, RAL 7035





**AKM 12**  
**Cable glands for knockouts M 12**

IP 66/67 IP 69

- sealing range: Ø 4-6 mm
- ISO thread M 12 x 1.5
- bore-hole: Ø 12.3 mm
- wall thickness up to 3 mm
- with strain relief and locknut
- for indoor (normal environment and/or protected outdoor) and outdoor installation (harsh environment and/or outdoor)
- ambient temperature - 25 °C to + 55 °C
- glow wire test IEC 60695-2-11: 960 °C
- Colour: grey, RAL 7035

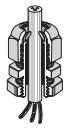

tightening torque	0,9 Nm
-------------------	--------



**AKM 16**  
**Cable glands for knockouts M 16**

IP 66/67 IP 69

- sealing range: Ø 5-10 mm
- ISO thread M 16 x 1.5
- bore-hole: Ø 16.3 mm
- wall thickness up to 3 mm
- with strain relief and locknut
- for indoor (normal environment and/or protected outdoor) and outdoor installation (harsh environment and/or outdoor)
- ambient temperature - 25 °C to + 55 °C
- glow wire test IEC 60695-2-11: 960 °C
- Colour: grey, RAL 7035



tightening torque	3.0 Nm
-------------------	--------



**AKM 20**  
**Cable glands for knockouts M 20**

IP 66/67 IP 69

- sealing range Ø 6,5-13,5 mm
- ISO thread M 20 x 1.5
- bore-hole: Ø 20.3 mm
- wall thickness up to 3 mm
- with strain relief and locknut
- for indoor (normal environment and/or protected outdoor) and outdoor installation (harsh environment and/or outdoor)
- ambient temperature - 25 °C to + 55 °C
- glow wire test IEC 60695-2-11: 960 °C
- Colour: grey, RAL 7035

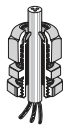

tightening torque	4.0 Nm
-------------------	--------



**AKM 25**  
**Cable glands for knockouts M 25**

IP 66/67 IP 69

- sealing range Ø 11-17 mm
- ISO thread M 25 x 1.5
- bore-hole: Ø 25.3 mm
- wall thickness up to 3 mm
- with strain relief and locknut
- for indoor (normal environment and/or protected outdoor) and outdoor installation (harsh environment and/or outdoor)
- ambient temperature - 25 °C to + 55 °C
- glow wire test IEC 60695-2-11: 960 °C
- Colour: grey, RAL 7035



tightening torque	7,5 Nm
-------------------	--------



**AKM 32**  
**Cable glands for knockouts M 32**

IP 66/67 IP 69

- sealing range Ø 15-21 mm
- ISO thread M 32 x 1.5
- bore-hole: Ø 32.3 mm
- wall thickness up to 3 mm
- with strain relief and locknut
- for indoor (normal environment and/or protected outdoor) and outdoor installation (harsh environment and/or outdoor)
- ambient temperature - 25 °C to + 55 °C
- glow wire test IEC 60695-2-11: 960 °C
- Colour: grey, RAL 7035



tightening torque	10,0 Nm
-------------------	---------



**AKM 40**  
**Cable glands for knockouts M 40**

IP 66/67 IP 69

- sealing range: Ø 19-28 mm
- ISO thread M 40 x 1.5
- bore-hole: Ø 40.3 mm
- wall thickness up to 3 mm
- with strain relief and locknut
- for indoor (normal environment and/or protected outdoor) and outdoor installation (harsh environment and/or outdoor)
- ambient temperature - 25 °C to + 55 °C
- glow wire test IEC 60695-2-11: 960 °C
- Colour: grey, RAL 7035



tightening torque	10,0 Nm
-------------------	---------



**AKM 50**  
**Cable glands for knockouts M 50**

IP 66/67 IP 69

- sealing range: Ø 27-35 mm
- ISO thread M 50 x 1.5
- bore-hole: Ø 50.3 mm
- wall thickness up to 3 mm
- with strain relief and locknut
- for indoor (normal environment and/or protected outdoor) and outdoor installation (harsh environment and/or outdoor)
- ambient temperature - 25 °C to + 55 °C
- glow wire test IEC 60695-2-11: 960 °C
- Colour: grey, RAL 7035



tightening torque	10,0 Nm
-------------------	---------



**AKM 63**  
**Cable glands for knockouts M 63**

IP 66/67 IP 69

- sealing range: Ø 35-42 mm
- ISO thread M 63 x 1.5
- bore-hole: Ø 63.3 mm
- wall thickness up to 3 mm
- with strain relief and locknut
- for indoor (normal environment and/or protected outdoor) and outdoor installation (harsh environment and/or outdoor)
- ambient temperature - 25 °C to + 55 °C
- glow wire test IEC 60695-2-11: 960 °C
- Colour: grey, RAL 7035



tightening torque	10,0 Nm
-------------------	---------



**ASS 12**  
**Cable glands for knockouts M 12**

IP 66/67 IP 69

- sealing range: Ø 2-5 mm
- ISO thread M 12 x 1.5
- bore-hole: Ø 12.3 mm
- wall thickness up to 3 mm
- with strain relief and locknut
- for indoor (normal environment and/or protected outdoor) and outdoor installation (harsh environment and/or outdoor)
- ambient temperature - 25 °C to + 55 °C
- glow wire test IEC 60695-2: 960 °C
- colour: black, RAL 9005

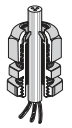

tightening torque	0,9 Nm
-------------------	--------



**ASS 16**  
**Cable glands for knockouts M 16**

IP 66/67 IP 69

- sealing range: Ø 3-10 mm
- ISO thread M 16 x 1.5
- bore-hole: Ø 16.3 mm
- wall thickness up to 3 mm
- with strain relief and locknut
- for indoor (normal environment and/or protected outdoor) and outdoor installation (harsh environment and/or outdoor)
- ambient temperature - 25 °C to + 55 °C
- glow wire test IEC 60695-2: 960 °C
- colour: black, RAL 9005

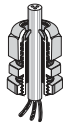

tightening torque	3.0 Nm
-------------------	--------



**ASS 20**  
**Cable glands or knockouts M 20**

IP 66/67 IP 69

- sealing range: Ø 5-13 mm
- ISO thread M 20 x 1.5
- bore-hole: Ø 20.3 mm
- wall thickness up to 3 mm
- with strain relief and locknut
- for indoor (normal environment and/or protected outdoor) and outdoor installation (harsh environment and/or outdoor)
- ambient temperature - 25 °C to + 55 °C
- glow wire test IEC 60695-2: 960 °C
- colour: black, RAL 9005

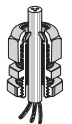

tightening torque	4.0 Nm
-------------------	--------



**ASS 25**  
**Cable glands for knockouts M 25**

IP 66/67 IP 69

- sealing range: Ø 8-17 mm
- ISO thread M 25 x 1.5
- bore-hole: Ø 25.3 mm
- wall thickness up to 3 mm
- with strain relief and locknut
- for indoor (normal environment and/or protected outdoor) and outdoor installation (harsh environment and/or outdoor)
- ambient temperature - 25 °C to + 55 °C
- glow wire test IEC 60695-2: 960 °C
- colour: black, RAL 9005



tightening torque	7,5 Nm
-------------------	--------



**ASS 32**

**Cable glands for knockouts M 32**

IP	IP
66/67	69

- sealing range: Ø 12-21 mm
- ISO thread M 32 x 1.5
- bore-hole: Ø 32.3 mm
- wall thickness up to 3 mm
- with strain relief and locknut
- for indoor (normal environment and/or protected outdoor) and outdoor installation (harsh environment and/or outdoor)
- ambient temperature - 25 °C to + 55 °C
- glow wire test IEC 60695-2: 960 °C
- colour: black, RAL 9005



tightening torque	10,0 Nm
-------------------	---------



**ASS 40**

**Cable glands for knockouts M 40**

IP	IP
66/67	69

- sealing range: Ø 16-28,5 mm
- ISO thread M 40 x 1.5
- bore-hole: Ø 40.3 mm
- wall thickness up to 3 mm
- with strain relief and locknut
- for indoor (normal environment and/or protected outdoor) and outdoor installation (harsh environment and/or outdoor)
- ambient temperature - 25 °C to + 55 °C
- glow wire test IEC 60695-2: 960 °C
- colour: black, RAL 9005



tightening torque	10,0 Nm
-------------------	---------



**ASS 50**

**Cable glands for knockouts M 50**

IP	IP
66/67	69

- sealing range: Ø 21-35 mm
- ISO thread M 50 x 1.5
- bore-hole: Ø 50.3 mm
- wall thickness up to 3 mm
- with strain relief and locknut
- for indoor (normal environment and/or protected outdoor) and outdoor installation (harsh environment and/or outdoor)
- ambient temperature - 25 °C to + 55 °C
- glow wire test IEC 60695-2: 960 °C
- colour: black, RAL 9005



tightening torque	10,0 Nm
-------------------	---------



**ASS 63**

**Cable glands for knockouts M 63**

IP	IP
66/67	69

- sealing range: Ø 20-48 mm
- ISO thread M 63 x 1.5
- bore-hole: Ø 63.3 mm
- wall thickness up to 3 mm
- with counter nut
- for indoor (normal environment and/or protected outdoor) and outdoor installation (harsh environment and/or outdoor)
- ambient temperature - 25 °C to + 55 °C
- glow wire test IEC 60695-2: 960 °C
- colour: black, RAL 9005



tightening torque	10,0 Nm
-------------------	---------

**Ventilation and cable entry in one!**

In general the formation of water in case of condensation in closed enclosures cannot be prevented in installation areas with high temperature differences!

For adherence to the requested degree of protection the ventilation of the enclosure is effected via a special combi climate gland.

Via an inserted, breathable membrane combi climate glands ensure pressure compensation between enclosure interior and ambient air.

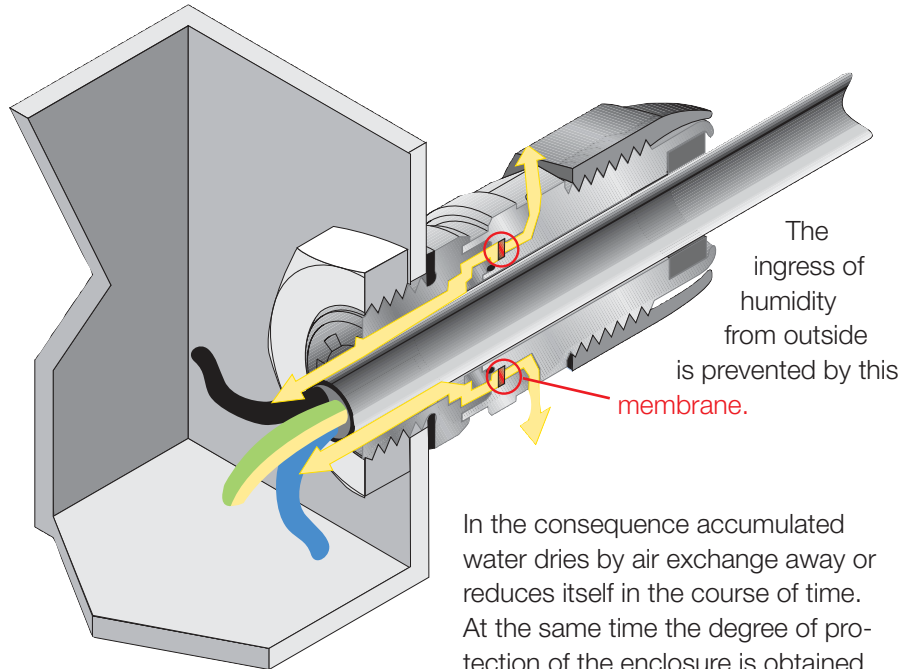

**The combi climate gland allows the cable entry and pressure compensation additionally.**

Combi climate glands prevent accumulations of condensation, which can form among others by large temperature fluctuations, like changing weather, intensive solar irradiation etc., in enclosures with high degree of protection.



**Your advantages with combi climate glands:**

- Cable entry and ventilation in one!
- Degree of protection of enclosure is obtained



**KBM 20**  
**Combi climate gland**  
**for knockouts M 20**

IP  
 66/67



- for the reduction of condensation by pressure compensation
- sealing range: Ø 6-13 mm
- ISO thread M 20 x 1.5
- bore-hole: Ø 20.5 mm
- wall thickness up to 3,5 mm
- with strain relief and locknut
- for indoor (normal environment and/or protected outdoor) and outdoor installation (harsh environment and/or outdoor)
- ambient temperature - 25 °C to + 55 °C
- glow wire test IEC 60695-2: 960 °C
- In order not to exceed leakage limit of 0.07 bar with pressure compensation, one combi climate gland M20 must be used per 6 litres (6000 cm<sup>3</sup>) of enclosure volume.
- Example: enclosure size 27 cm x 27 cm x 17 cm = 12393 cm<sup>3</sup> = 12,393 litres. Number of necessary combi climate glands M20 ≥ 3 pieces.
- When using different gland sizes the values for the enclosure volumes of the used combi climate glands can be added on.
- If the quantity of the necessary climate glands for pressure compensation is larger, than the number of necessary cable glands for cable entry, the unused climate glands can be sealed with sealing plugs.
- Colour: grey, RAL 7035

tightening torque

3.0 Nm



**KBM 25**  
**Combi climate gland**  
**for knockouts M 25**

IP  
 66/67



- for the reduction of condensation by pressure compensation
- sealing range: Ø 9-17 mm
- ISO thread M 25 x 1.5
- bore-hole: Ø 25.5 mm
- wall thickness up to 3,5 mm
- with strain relief and locknut
- for indoor (normal environment and/or protected outdoor) and outdoor installation (harsh environment and/or outdoor)
- ambient temperature - 25 °C to + 55 °C
- glow wire test IEC 60695-2: 960 °C
- In order not to exceed leakage limit of 0.07 bar with pressure compensation, one combi climate gland M25 must be used per 10 litres (10000 cm<sup>3</sup>) of enclosure volume.
- Example: enclosure size 27 cm x 27 cm x 17 cm = 12393 cm<sup>3</sup> = 12,393 litres. Number of necessary combi climate glands M25 ≥ 2 pieces
- When using different gland sizes the values for the enclosure volumes of the used combi climate glands can be added on.
- If the quantity of the necessary climate glands for pressure compensation is larger, than the number of necessary cable glands for cable entry, the unused climate glands can be sealed with sealing plugs.
- Colour: grey, RAL 7035

tightening torque

4.0 Nm



Combi climate glands in application



**KBM 32**  
**Combi climate gland**  
**for knockouts M 32**

IP  
66/67

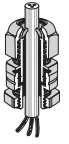

- for the reduction of condensation by pressure compensation
- sealing range: Ø 13-21 mm
- ISO thread M 32 x 1.5
- bore-hole: Ø 32.5 mm
- wall thickness up to 3,5 mm
- with strain relief and locknut
- for indoor (normal environment and/or protected outdoor) and outdoor installation (harsh environment and/or outdoor)
- ambient temperature - 25 °C to + 55 °C
- glow wire test IEC 60695-2: 960 °C
- In order not to exceed leakage limit of 0.07 bar with pressure compensation, one combi climate gland M32 must be used per 12 litres (12000 cm<sup>3</sup>) of enclosure volume.
- Example: enclosure size 27 cm x 27 cm x 17 cm = 12393 cm<sup>3</sup> = 12,393 litres.  
Number of necessary combi climate glands M32 ≥ 2 piece.
- When using different gland sizes the values for the enclosure volumes of the used combi climate glands can be added on.
- If the quantity of the necessary climate glands for pressure compensation is larger, than the number of necessary cable glands for cable entry, the unused climate glands can be sealed with sealing plugs.
- Colour: grey, RAL 7035

tightening torque

4.0 Nm



**KBM 40**  
**Combi climate gland**  
**for knockouts M 40**

IP  
66/67

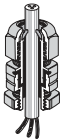

- for the reduction of condensation by pressure compensation
- sealing range: Ø 16-28 mm
- ISO thread M 40 x 1.5
- bore-hole: Ø 40,5 mm
- wall thickness up to 3 mm
- with strain relief and locknut
- for indoor (normal environment and/or protected outdoor) and outdoor installation (harsh environment and/or outdoor)
- ambient temperature - 25 °C to + 55 °C
- glow wire test IEC 60695-2: 960 °C
- In order not to exceed leakage limit of 0.07 bar with pressure compensation, one combi climate gland M40 must be used per 16 litres (16000 cm<sup>3</sup>) of enclosure volume.
- Example: enclosure size 27 cm x 27 cm x 17 cm = 12393 cm<sup>3</sup> = 12.393 litres. Number of necessary KB. 40 (M40) ≥ 1 piece.
- When using different gland sizes the values for the enclosure volumes of the used combi climate glands can be added on.
- If the quantity of the necessary climate glands for pressure compensation is larger, than the number of necessary cable glands for cable entry, the unused climate glands can be sealed with sealing plugs.
- Colour: grey, RAL 7035

tightening torque

6.0 Nm



**KBS 20**  
**Combi climate gland**  
**for knockouts M 20**

IP  
 66/67



- for the reduction of condensation by pressure compensation
- sealing range: Ø 6-13 mm
- ISO thread M 20 x 1.5
- bore-hole: Ø 20.5 mm
- wall thickness up to 3,5 mm
- with strain relief and locknut
- for indoor (normal environment and/or protected outdoor) and outdoor installation (harsh environment and/or outdoor)
- ambient temperature - 25 °C to + 55 °C
- glow wire test IEC 60695-2: 960 °C
- In order not to exceed leakage limit of 0.07 bar with pressure compensation, one combi climate gland M20 must be used per 6 litres (6000 cm<sup>3</sup>) of enclosure volume.
- Example: enclosure size 27 cm x 27 cm x 17 cm = 12393 cm<sup>3</sup> = 12,393 litres.  
 Number of necessary combi climate glands M20 ≥ 3 pieces.
- When using different gland sizes the values for the enclosure volumes of the used combi climate glands can be added on.
- If the quantity of the necessary climate glands for pressure compensation is larger, than the number of necessary cable glands for cable entry, the unused climate glands can be sealed with sealing plugs.
- colour: black, RAL 9005

tightening torque

3.0 Nm



**KBS 25**  
**Combi climate gland**  
**for knockouts M 25**

IP  
 66/67



- for the reduction of condensation by pressure compensation
- sealing range: Ø 9-17 mm
- ISO thread M 25 x 1.5
- bore-hole: Ø 25.5 mm
- wall thickness up to 3,5 mm
- with strain relief and locknut
- for indoor (normal environment and/or protected outdoor) and outdoor installation (harsh environment and/or outdoor)
- ambient temperature - 25 °C to + 55 °C
- glow wire test IEC 60695-2: 960 °C
- In order not to exceed leakage limit of 0.07 bar with pressure compensation, one combi climate gland M25 must be used per 10 litres (10000 cm<sup>3</sup>) of enclosure volume.
- Example: enclosure size 27 cm x 27 cm x 17 cm = 12393 cm<sup>3</sup> = 12,393 litres.  
 Number of necessary combi climate glands M25 ≥ 2 pieces
- When using different gland sizes the values for the enclosure volumes of the used combi climate glands can be added on.
- If the quantity of the necessary climate glands for pressure compensation is larger, than the number of necessary cable glands for cable entry, the unused climate glands can be sealed with sealing plugs.
- colour: black, RAL 9005

tightening torque

4.0 Nm



Combi climate glands in application



**KBS 32**  
**Combi climate gland**  
**for knockouts M 32**

IP  
66/67

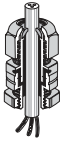

- for the reduction of condensation by pressure compensation
- sealing range: Ø 13-21 mm
- ISO thread M 32 x 1.5
- bore-hole: Ø 32.5 mm
- wall thickness up to 3,5 mm
- with strain relief and locknut
- for indoor (normal environment and/or protected outdoor) and outdoor installation (harsh environment and/or outdoor)
- ambient temperature - 25 °C to + 55 °C
- glow wire test IEC 60695-2: 960 °C
- In order not to exceed leakage limit of 0.07 bar with pressure compensation, one combi climate gland M32 must be used per 12 litres (12000 cm<sup>3</sup>) of enclosure volume.
- Example: enclosure size 27 cm x 27 cm x 17 cm = 12393 cm<sup>3</sup> = 12,393 litres.  
Number of necessary combi climate glands M32 ≥ 2 piece.
- When using different gland sizes the values for the enclosure volumes of the used combi climate glands can be added on.
- If the quantity of the necessary climate glands for pressure compensation is larger, than the number of necessary cable glands for cable entry, the unused climate glands can be sealed with sealing plugs.
- colour: black, RAL 9005

tightening torque

4.0 Nm



**KBS 40**  
**Combi climate gland**  
**for knockouts M 40**

IP  
66/67

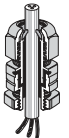

- for the reduction of condensation by pressure compensation
- sealing range: Ø 16-28 mm
- ISO thread M 40 x 1.5
- bore-hole: Ø 40,5 mm
- wall thickness up to 3 mm
- with strain relief and locknut
- for indoor (normal environment and/or protected outdoor) and outdoor installation (harsh environment and/or outdoor)
- ambient temperature - 25 °C to + 55 °C
- glow wire test IEC 60695-2: 960 °C
- In order not to exceed leakage limit of 0.07 bar with pressure compensation, one combi climate gland M40 must be used per 16 litres (16000 cm<sup>3</sup>) of enclosure volume.
- Example: enclosure size 27 cm x 27 cm x 17 cm = 12393 cm<sup>3</sup> = 12.393 litres. Number of necessary KB. 40 (M40) ≥ 1 piece.
- When using different gland sizes the values for the enclosure volumes of the used combi climate glands can be added on.
- If the quantity of the necessary climate glands for pressure compensation is larger, than the number of necessary cable glands for cable entry, the unused climate glands can be sealed with sealing plugs.
- colour: black, RAL 9005

tightening torque

6.0 Nm



**VSB 13**

**Sealing plug  
diameter 13 mm**

- for sealing combi climate glands M20 or M25, which are not used for cable entry
- ambient temperature - 25 °C to + 55 °C
- colour: red, RAL 3000



**VSB 21**

**Sealing plug  
diameter 21 mm**

- for sealing combi climate glands M32 and M40, which are not used for cable entry
- ambient temperature - 25 °C to + 55 °C
- colour: red, RAL 3000

Application:



Combi climate glands in application



**BM 20G**

**Pressure compensation element for M 20 knockouts**

- for the reduction of condensation by pressure compensation in power distribution systems
- ISO thread M 20 x 1.5
- bore-hole: Ø 20.3 mm
- wall thickness up to 4 mm
- with counter nut
- for indoor (normal environment and/or protected outdoor) and outdoor installation (harsh environment and/or outdoor)
- ambient temperature - 25 °C to + 55 °C
- In order not to exceed leakage limit of 0.07 bar with pressure compensation, one pressure compensation element BM 20G must be used per 28 litres (28000 cm³) of enclosure volume.
- Example:  
 enclosure size 30 cm x 60 cm x 17 cm = 30600 cm³ = 30.6 litres.  
 Number of necessary BM 20G (M32) = 2 piece.
- technical changes reserved
- Colour: grey, RAL 7035

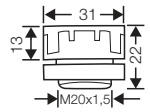

**BM 40G**

**Pressure compensation element for M 40 knockouts**

- for the reduction of condensation by pressure compensation in power distribution systems
- ISO thread M 40 x 1.5
- bore-hole: Ø 40.3 mm
- wall thickness of up to 8 mm
- with counter nut
- for indoor (normal environment and/or protected outdoor) and outdoor installation (harsh environment and/or outdoor)
- ambient temperature - 25 °C to + 55 °C
- In order not to exceed leakage limit of 0.07 bar with pressure compensation, one pressure compensation element BM 40G must be used per 122 litres (122000 cm³) of enclosure volume.
- Example:  
 enclosure size 60 cm x 60 cm x 17 cm = 61200 cm³ = 61.2 litres.  
 Number of necessary BM 40G (M40) = 1 piece.
- technical changes reserved
- Colour: grey, RAL 7035

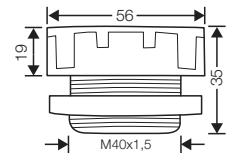

Pressure compensation elements reduce condensation in power distribution systems

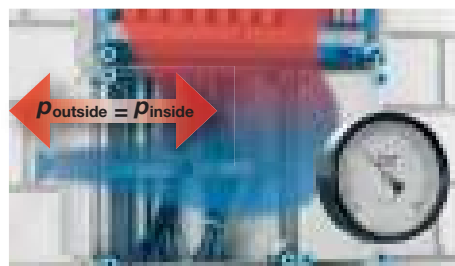



**KST 70**  
**Stepped grommet**

- sealing range: Ø 30-72 mm
- bore-hole: Ø 83 mm
- wall thickness 1.5-3 mm
- for indoor - normal environment and (or) protected outdoor installation
- ambient temperature - 25 °C to + 35 °C
- glow wire test IEC 60695-2-11: 750 °C

IP  
65



**MV FP 66**  
**Flange**

- with cable entry glands and screws
- sealing range: Ø 30-72 mm
- wall thickness of at least 1.5 mm

IP  
55

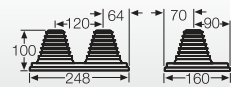

**KHR 01**  
**Cable retention**  
**for cable diameter 6.5 - 14 mm**

- set with 10 x 6 cable retention rings
- 30 pieces for cable diameter 6,5 - 10 mm
- 30 pieces for cable diameter 10 - 14 mm



**KHR 02**  
**Cable retention**  
**for cable diameter 10 - 16 mm**

- set with 10 x 6 cable retention rings
- 30 pieces for cable diameter 10 - 14 mm
- 30 pieces for cable diameter 13 - 16 mm

Outside diameter of conventional cable cross sections. The outside diameters are average values of different products.

Cable cross section	NYM	NYY	NYCY NYCWY
1x4 mm <sup>2</sup>	Ø 8 mm	Ø 9 mm	—
1x6 mm <sup>2</sup>	Ø 8.5 mm	Ø 10 mm	—
1x10 mm <sup>2</sup>	Ø 9.5 mm	Ø 10.5 mm	—
1x16 mm <sup>2</sup>	Ø 11 mm	Ø 12 mm	—
1x25 mm <sup>2</sup>	—	Ø 14 mm	—
1x35 mm <sup>2</sup>	—	Ø 15 mm	—
1x50 mm <sup>2</sup>	—	Ø 16.5 mm	—
1x70 mm <sup>2</sup>	—	Ø 18 mm	—
1x95 mm <sup>2</sup>	—	Ø 20 mm	—
1x120 mm <sup>2</sup>	—	Ø 21 mm	—
1x150 mm <sup>2</sup>	—	Ø 23 mm	—
1x185 mm <sup>2</sup>	—	Ø 25 mm	—
1x240 mm <sup>2</sup>	—	Ø 28 mm	—
1x300 mm <sup>2</sup>	—	Ø 30 mm	—
2x1.5 mm <sup>2</sup>	Ø 10 mm	Ø 12 mm	—
2x2.5 mm <sup>2</sup>	Ø 11 mm	Ø 13 mm	—
2x4 mm <sup>2</sup>	—	Ø 15 mm	—
2x6 mm <sup>2</sup>	—	Ø 16 mm	—
2x10 mm <sup>2</sup>	—	Ø 18 mm	—
2x16 mm <sup>2</sup>	—	Ø 20 mm	—
2x25 mm <sup>2</sup>	—	—	—
2x35 mm <sup>2</sup>	—	—	—
3x1.5 mm <sup>2</sup>	Ø 10.5 mm	Ø 12.5 mm	Ø 13 mm
3x2.5 mm <sup>2</sup>	Ø 11 mm	Ø 13 mm	Ø 14 mm
3x4 mm <sup>2</sup>	Ø 13 mm	Ø 16 mm	Ø 16 mm
3x6 mm <sup>2</sup>	Ø 15 mm	Ø 17 mm	Ø 17 mm
3x10 mm <sup>2</sup>	Ø 18 mm	Ø 19 mm	Ø 18 mm
3x16 mm <sup>2</sup>	Ø 20 mm	Ø 21 mm	Ø 21 mm
3x25 mm <sup>2</sup>	—	Ø 26 mm	—
3x35 mm <sup>2</sup>	—	—	—
3x50 mm <sup>2</sup>	—	—	—
3x70 mm <sup>2</sup>	—	—	—
3x95 mm <sup>2</sup>	—	—	—
3x120 mm <sup>2</sup>	—	—	—
3x150 mm <sup>2</sup>	—	—	—
3x185 mm <sup>2</sup>	—	—	—
3x240 mm <sup>2</sup>	—	—	—
3x25/16 mm <sup>2</sup>	—	Ø 27 mm	Ø 27 mm
3x35/16 mm <sup>2</sup>	—	Ø 28 mm	Ø 27 mm
3x50/25 mm <sup>2</sup>	—	Ø 32 mm	Ø 32 mm
3x70/35 mm <sup>2</sup>	—	Ø 32-36 mm	Ø 36 mm
3x95/50 mm <sup>2</sup>	—	Ø 37-41 mm	Ø 40 mm
3x120/70 mm <sup>2</sup>	—	Ø 42 mm	Ø 43 mm
3x150/70 mm <sup>2</sup>	—	Ø 46 mm	Ø 47 mm
3x185/95 mm <sup>2</sup>	—	Ø 52 mm	Ø 48-54 mm
3x240/120 mm <sup>2</sup>	—	Ø 57-63 mm	Ø 60 mm
3x300/150 mm <sup>2</sup>	—	Ø 63-69 mm	—

Cable cross section	NYM	NYY	NYCY NYCWY
4x1.5 mm <sup>2</sup>	Ø 11 mm	Ø 13.5 mm	Ø 14 mm
4x2.5 mm <sup>2</sup>	Ø 12.5 mm	Ø 14.5 mm	Ø 15 mm
4x4 mm <sup>2</sup>	Ø 14.5 mm	Ø 17.5 mm	Ø 17 mm
4x6 mm <sup>2</sup>	Ø 16.5 mm	Ø 18 mm	Ø 18 mm
4x10 mm <sup>2</sup>	Ø 18.5 mm	Ø 20 mm	Ø 20 mm
4x16 mm <sup>2</sup>	Ø 23.5 mm	Ø 23 mm	Ø 23 mm
4x25 mm <sup>2</sup>	Ø 28.5 mm	Ø 28 mm	Ø 28 mm
4x35 mm <sup>2</sup>	Ø 32 mm	Ø 26-30 mm	Ø 29 mm
4x50 mm <sup>2</sup>	—	Ø 30-35 mm	Ø 34 mm
4x70 mm <sup>2</sup>	—	Ø 34-40 mm	Ø 37 mm
4x95 mm <sup>2</sup>	—	Ø 38-45 mm	Ø 42 mm
4x120 mm <sup>2</sup>	—	Ø 42-50 mm	Ø 47 mm
4x150 mm <sup>2</sup>	—	Ø 46-53 mm	Ø 52 mm
4x185 mm <sup>2</sup>	—	Ø 53-60 mm	Ø 60 mm
4x240 mm <sup>2</sup>	—	Ø 59-71 mm	Ø 70 mm
4x25/16 mm <sup>2</sup>	—	—	Ø 30 mm
4x35/16 mm <sup>2</sup>	—	—	Ø 30 mm
4x50/25 mm <sup>2</sup>	—	—	Ø 36.5 mm
4x70/35 mm <sup>2</sup>	—	—	Ø 40 mm
4x95/50 mm <sup>2</sup>	—	—	Ø 44.5 mm
4x120/70 mm <sup>2</sup>	—	—	Ø 48.5 mm
4x150/70 mm <sup>2</sup>	—	—	Ø 53 mm
4x185/95 mm <sup>2</sup>	—	—	—
4x240/120 mm <sup>2</sup>	—	—	—
5x1.5 mm <sup>2</sup>	Ø 12 mm	Ø 15 mm	Ø 15 mm
5x2.5 mm <sup>2</sup>	Ø 13.5 mm	Ø 16 mm	Ø 17 mm
5x4 mm <sup>2</sup>	Ø 15.5 mm	Ø 16.5 mm	Ø 18 mm
5x6 mm <sup>2</sup>	Ø 18 mm	Ø 19 mm	Ø 20 mm
5x10 mm <sup>2</sup>	Ø 20 mm	Ø 21 mm	—
5x16 mm <sup>2</sup>	Ø 26 mm	Ø 24 mm	—
5x25 mm <sup>2</sup>	Ø 31.5 mm	—	—
7x1.5 mm <sup>2</sup>	Ø 13 mm	Ø 16 mm	—
7x2.5 mm <sup>2</sup>	Ø 14.5 mm	Ø 16.5 mm	—
19x1.5 mm <sup>2</sup>	—	Ø 22 mm	—
24x1.5 mm <sup>2</sup>	—	Ø 25 mm	—

Assignment of cable outside diameters to cable entries (glands, grommets etc.)

Outside diameters of cables		Cable entry metric
Ø min.	Ø max.	
3 mm	6 mm	AKM/ASS 12
5 mm	10 mm	AKM/ASS 16
6.5 mm	13.5 mm	AKM/ASS 20
11 mm	17 mm	AKM/ASS 25
15 mm	21 mm	AKM/ASS 32
19 mm	28 mm	AKM/ASS 40
27 mm	35 mm	AKM/ASS 50
35 mm	42 mm	AKM/ASS 63
4.8 mm	11 mm	ESM 16
6 mm	13 mm	ESM 20
9 mm	17 mm	ESM 25
9 mm	23 mm	ESM 32
17 mm	30 mm	ESM 40
3.5 mm	12 mm	STM 16
5 mm	16 mm	STM 20
5 mm	21 mm	STM 25
13 mm	26.5 mm	STM 32
13 mm	34 mm	STM 40

Outside diameters of cables		Cable entry metric
Ø min.	Ø max.	
5 mm	10 mm	EDK 16
6 mm	13 mm	EDK 20
9 mm	17 mm	EDK 25
8 mm	23 mm	EDK 32
11 mm	30 mm	EDK 40
conduit connection		
M 16		EDR 16
M 20		EDR 20
M 25		EDR 25
M 32		EDR 32
M 40		EDR 40



**AKS 9**  
for knockouts Pg 9

- sealing range: Ø 4-8 mm
- for bore-hole Pg 9, Ø 15.5 mm
- wall thickness up to 3 mm
- with strain relief and locknut
- for indoor (normal environment and/or protected outdoor) and outdoor installation (harsh environment and/or outdoor)
- ambient temperature - 25 °C to + 55 °C
- glow wire test IEC 60695-2-11: 960 °C
- Colour: grey, RAL 7035



**AKS 11**  
for knockouts Pg 11

- sealing range: Ø 5-10 mm
- for bore-hole Pg 11, Ø 19 mm
- wall thickness up to 3 mm
- with strain relief and locknut
- for indoor (normal environment and/or protected outdoor) and outdoor installation (harsh environment and/or outdoor)
- ambient temperature - 25 °C to + 55 °C
- glow wire test IEC 60695-2-11: 960 °C
- Colour: grey, RAL 7035



**AKS 13,5**  
for knockouts Pg 13.5

- sealing range: Ø 6-12 mm
- bore-hole Pg 13,5, Ø 21 mm
- wall thickness up to 3 mm
- with strain relief and locknut
- for indoor (normal environment and/or protected outdoor) and outdoor installation (harsh environment and/or outdoor)
- ambient temperature - 25 °C to + 55 °C
- glow wire test IEC 60695-2-11: 960 °C
- Colour: grey, RAL 7035



**AKS 16**  
for knockouts Pg 16

- sealing range: Ø 10-14 mm
- for bore-hole Pg 16, Ø 23 mm
- wall thickness up to 4 mm
- with strain relief and locknut
- for indoor (normal environment and/or protected outdoor) and outdoor installation (harsh environment and/or outdoor)
- ambient temperature - 25 °C to + 55 °C
- glow wire test IEC 60695-2-11: 960 °C
- Colour: grey, RAL 7035



**AKS 21**  
for knockouts Pg 21

- sealing range: Ø 13-18 mm
- for bore-hole Pg 21, Ø 29 mm
- wall thickness up to 4 mm
- with strain relief and locknut
- for indoor (normal environment and/or protected outdoor) and outdoor installation (harsh environment and/or outdoor)
- ambient temperature - 25 °C to + 55 °C
- glow wire test IEC 60695-2-11: 960 °C
- Colour: grey, RAL 7035





**AKS 29**  
**for knockouts Pg 29**

IP  
65

- sealing range: Ø 18-25 mm
- for bore-hole Pg 29, Ø 37.5 mm
- wall thickness up to 4 mm
- with strain relief and locknut
- for indoor (normal environment and/or protected outdoor) and outdoor installation (harsh environment and/or outdoor)
- ambient temperature - 25 °C to + 55 °C
- glow wire test IEC 60695-2-11: 960 °C
- Colour: grey, RAL 7035



**AKS 36**  
**for knockouts Pg 36**

IP  
65

- sealing range: Ø 22-32 mm
- for bore-hole Pg 36, Ø 47.5 mm
- wall thickness of up to 5 mm
- with strain relief and locknut
- for indoor (normal environment and/or protected outdoor) and outdoor installation (harsh environment and/or outdoor)
- ambient temperature - 25 °C to + 55 °C
- glow wire test IEC 60695-2-11: 960 °C
- Colour: grey, RAL 7035

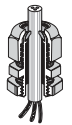

**AKS 42**  
**for knockouts Pg 42**

IP  
65

- sealing range: Ø 30-38 mm
- for bore-hole Pg 42, Ø 54,5 mm
- wall thickness of up to 5 mm
- with strain relief and locknut
- for indoor (normal environment and/or protected outdoor) and outdoor installation (harsh environment and/or outdoor)
- ambient temperature - 25 °C to + 55 °C
- glow wire test IEC 60695-2-11: 960 °C
- Colour: grey, RAL 7035



**AKS 48**  
**for knockouts Pg 48**

IP  
65

- sealing range: Ø 34-44 mm
- bore-hole Pg 48, Ø 60 mm
- wall thickness of up to 6 mm
- with strain relief and locknut
- for indoor (normal environment and/or protected outdoor) and outdoor installation (harsh environment and/or outdoor)
- ambient temperature - 25 °C to + 55 °C
- glow wire test IEC 60695-2-11: 960 °C
- Colour: grey, RAL 7035

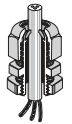



## Cable entry systems

### Technical details

Dimensions	418
Operating and ambient conditions	419

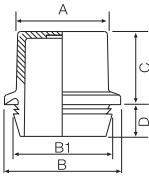
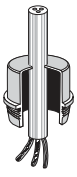

Grommets in mm	A	B	B1	C	D
ESM 16	16.5	22	18.5	14.5	8.5
ESM 20	20.5	26	22.5	14.5	8.5
ESM 25	26.0	31	27.5	14.5	8.5
ESM 32	33.0	38	34.5	17.5	8.5
ESM 40	41.0	46	42.5	17.5	8.5

**Grommets ESM**

Degree of protection IP 55  
Grommets ESM are inserted into knockouts. There is no counter nut required!

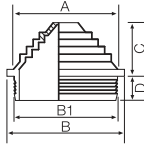
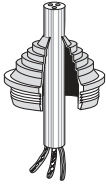

Stepped grommets in mm	A	B	B1	C	D
STM 16	13.2	21.2	19	7.4	8.0
STM 20	18.0	25	23	9.2	8.0
STM 25	21.6	30	28	11.5	7.4
STM 32	27.6	37	35	11.5	8.6
STM 40	33.6	45	43	15.1	8.6

**Stepped grommets STM**

Degree of protection IP 55  
Stepped glands STM are inserted into knockouts. There is no counter nut required!

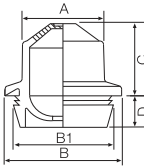
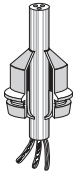

Grommets in mm	A	B	B1	C	D
EDK 16	14.5	22	18.5	13.5	8.5
EDK 20	18.5	26	22.5	14.5	8.5
EDK 25	23.5	31	27.5	14.5	8.5
EDK 32	30.5	38	34.5	19.5	8.5
EDK 40	38.5	46	42.5	19.5	8.5

**Grommets EDK**

Degree of protection IP 65  
Grommets EDK are inserted into knockouts. There is no counter nut required!

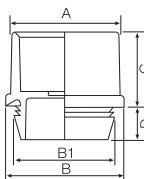
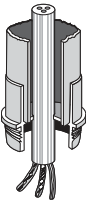

Grommets for conduits in mm	A	B	B1	C	D
EDR 16	20	22	18.5	14.5	8.5
EDR 20	24	26	22.5	14.5	8.5
EDR 25	29	31	27.5	14.5	8.5
EDR 32	36	38	34.5	17.5	8.5
EDR 40	44	46	42.5	17.5	8.5

**Grommets for conduits EDR**

Degree of protection IP 65  
Grommets for conduits EDR are inserted into knockouts. There is no counter nut required!

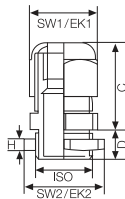
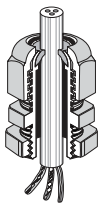

Cable glands AKM/ASS with strain relief counter nut, degree of protection IP 65								
in mm	ISO	SW1 across flats	EK1 across corners Ø	C max.	D	SW2 across flats	EKS across corners Ø	H
AKM/ASS 12	M 12	15	16.4	22	8	17	19.0	5
AKM/ASS 16	M 16	20	22.0	26	8	22	24.7	5
AKM/ASS 20	M 20	24	26.5	29	8	27	30.2	6
AKM/ASS 25	M 25	29	32.0	34	8	32	36.0	6
AKM/ASS 32	M 32	36	39.7	39	10	41	46.0	7
AKM/ASS 40	M 40	46	50.5	46	10	50	54.1	7
AKM/ASS 50	M 50	55	60.0	51	10	60	66.3	8
AKM/ASS 63	M 63	68	74.7	55	10	75	83.0	8

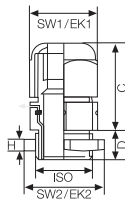
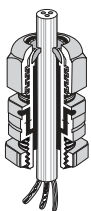

Combi climate glands KBM / KBS with strain relief counter nut, degree of protection IP 66 / IP 67								
in mm	ISO	SW1 across flats	EK1 across corners Ø	C max.	D	SW2 across flats	EK2 across corners Ø	H
KBM/KBS 20	M 20	24	27.0	42	8	27	29.0	5
KBM/KBS 25	M 25	29	32.0	45	8	32	35.5	5
KBM/KBS 32	M 32	36	40.0	47	10	40	44.5	6
KBM/KBS 40	M 40	46	50.5	59	10	50	54.1	7

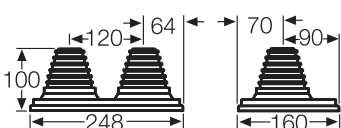

**Flange MV FP 66**

Degree of protection IP 55  
for retrofitting onto boxes made of sheet steel material thickness ≥ 1.5 mm

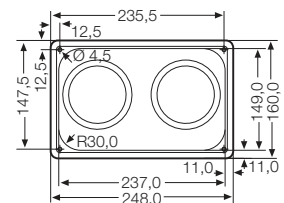

	ESM ... STM ... EDK ... EDR ... KST... MV FP 66	AKM ... ASS ...	AKS ... KBM ... KBS ...
<b>Application area</b>	Suitable for indoor installation (normal environment and/or protected outdoor)	Suitable for <b>outdoor installation</b> - harsh environment and / or outdoor	
<b>Ambient temperature</b>			
- Average value over 24 hours	+ 35 °C	+ 55 °C	+ 55 °C
- Maximum value	+ 40 °C	+ 70 °C	+ 70 °C
- Minimum value	- 25 °C	- 25 °C	- 25 °C
<b>Fire protection</b> in the event of internal faults	Demands placed on electrical devices from standards and laws:  Minimum requirements - Glow wire test in accordance with IEC 60695-2-11: - 650 °C for boxes and Cable glands		
<b>Burning behaviour</b>			
- Glow wire test IEC 60695-2-11	750 °C	960 °C	960 °C
- UL Subject 94	flame-retardant self-extinguishing	V-0 flame-retardant self-extinguishing	V-2 flame-retardant self-extinguishing
<b>Toxic behaviour</b>	halogen-free silicone-free	halogen-free silicone-free	halogen-free silicone-free
	"Halogen-free" in accordance with IEC 60754-2 "Common test methods for cables - Determination of the amount of halogen acid gas". For material properties see technical data.		



## Technical data

Material properties	424
Directive 2011/65/EC (RoHS), Regulation (EC) No 1907/2006 REACH	425
Degrees of protection provided by enclosures (IP Code)	426 - 427
Recommendation for outdoor installations, humid and wet areas and locations	428
Formation of condensed water and retaliatory actions	429 - 430
International Short Forms of Types of Conductors	431
IK-Code	431
Outside diameter of conventional cable cross-sections	432
Short Forms of Cables	432
Assignment of cable outside diameters to cable glands	433
Standards	433
Terminal Technology	434 - 435
Preparation of Aluminum Conductors	436
Tested quality	437
Definition of terms	438
EC Declaration of Conformity	439
Further technical information can be found on the Internet <a href="http://www.hensel-electric.de">www.hensel-electric.de</a> -> Products	

**Technical data**  
**Material properties**

Products	Material used	Glow wire test IEC 60 695-2- 11	UL Subject 94	Temperature resistance	Chemical resistance <sup>1)</sup>					
					Acid 10 %	Lye 10 %	Alcohol	Petrol (MAK) <sup>2)</sup>	Benzene (MAK) <sup>2)</sup>	Minerar oil
<b>DK 02.. / DK 04.. / DK 06.. / DK 10.. / RK 02.. / RK 04.. / DN ....</b>	PP (polypropylene)	750 °C	V-2	-25 °C / +80 °C	+	+	+	0	-	0
<b>DK 16.. / DK 25.. / DK 35.. / DK 50..</b>	PC (Polycarbonat)	750 °C	V-2	-40 °C / +120 °C	+	+	0	+	-	+
<b>KF .... G / KF .... H / KF .... B / KF .... C WP .... / bottom parts of Mi ... / FP ... / SB FK 04.. / FK 06.. / FK 16..</b>	PC (polycarbonat) (with GFS)	960 °C	V-0	-40 °C / +120 °C	+	+	0	+	-	+
<b>K 12.. / K 24.. lid Mi ... / SB ... / door and lid KV ... / door and lid KV PC .. / door and frame FP ... / hinged lid KG ...</b>	PC (Polycarbonat)	960 °C	V-0	-40 °C / +120 °C	+	+	0	+	-	+
<b>DE .... / DP .... KV .... / KG ....</b>	PS (Polystyrol)	750 °C	V-2	-40 °C / +70 °C	+	+	+	-	-	0
<b>Sealings DK 02.. / DK 04.. / DK 06.. / DK 10.. / DK 16.. / RK 02.. / RK 04.. / KF 02.. / KF 04.. / KF 06.. / KF 10.. / KF 16.. DP ... / DPC ... / DE ... / KV ... / KV PC ... / KF PV ... / Mi FP ... / FP FG ... ESM .. / STM .. / EDK .. / EDR .. / KST .. / DPS .. / ERA .. / EKA .. / EVS ..</b>	TPE (Thermo- plastisches Elastomer)	750 °C	-	-25 °C / +100 °C	+	+	+	0	0	0
<b>Sealings DK 25.. / DK 35.. / DK 50.. / KF 25.. / KF 35.. / KF 50.. K ... / KV ... / KV PC ... / Mi ... / FP ... / SB ...</b>	PUR (polyurethane)	-	-	-25 °C / +80 °C	0	+	0	0	-	+
<b>AKM .. / ASS .. / BM ...</b>	PA (polyamide)	960 °C	V-0	-40 °C / +100 °C	+	0	+	+	+	+
<b>AKS .. KBM .. / KBS ..</b>	PA (polyamide)	960 °C	V-2	-40 °C / +100 °C	+	0	+	+	+	+
<b>AVS .. / AFM ..</b>	PA (polyamide)	750 °C	V-2	-40 °C / +100 °C	+	0	+	+	+	+
<b>Sealings AKM .. / AKS .. / AKS ..</b>	CR/NBR (polychloroprene - nitrile rubber)	-	-	-20 °C / +100 °C	+	+	+	0	-	0
<b>Sealings - inner part ASS ..</b>	TPE (Evoprene)	-	-	-30 °C / +100 °C	+	-	+	-	-	-
<b>Sealings - outer part ASS ..</b>	CR (chloroprene rubber)	-	-	-30 °C / +100 °C	+	+	+	0	-	0
<b>Sealings KBM .. / KBS ..</b>	EPDM ethylene propylene diene monomer rubber	-	-	-40 °C / +130 °C	+	+	+	-	-	-

(+ = resistance; 0 = partially resistance; - = not resistant)

As at: January 2017

1) The specifications on chemical resistance are a general guide. In individual cases it may be necessary to check resistance in combination with other chemicals and ambient conditions (temperature, concentration, etc.)

2) (MAK) - Maximum allowable concentration (work place)

## Technical data

### RoHS, REACH

#### Directive 2011/65/EU (RoHS)

We state all these details according to the best of our knowledge. They correspond to the present state of the art. This information is not to be understood as a warranty in the sense of warranty law.

Under the intended use, our products do not fall within the scope of the Electrical Equipment Act (Electrical and Electronic Equipment).

#### The following product series comply with Directive 2002/65/EC (RoHS):

- **ENYCASE**<sup>®</sup> DK Cable junction boxes
- **ENYBOARD** KV Small-type distribution boards
- **ENYSTAR**<sup>®</sup> Distribution boards with door (empty enclosures, circuit breaker boxes)
- **ENYMOD** Mi Power distribution boards (empty boxes, circuit breaker boxes)
- **ENYFLEX** Empty enclosures in according with IEC 62208
- **ENYFIT** Cable entry systems

#### Regulation (EC) No 1907/2006 REACH

Gustav Hensel GmbH & Co. KG meets the requirements set by REACH (EG) No. 1907/2006. We shall inform you in the framework of our business relations about the changes to our products resulting from REACH and agree on suitable measures on a case-by-case basis.

As far as article 33 of REACH is concerned, we hereby inform you that our products and their packaging materials do not contain any substances on the candidate list according to article 59 (1, 10) of the above-mentioned regulation in a concentration above 0.1 % weight by weight (as of 12/17/2015).

## Technical data

### Degrees of protection provided by enclosures (IP Code)

#### Degrees of protection according to IEC 60 529

##### Degree of protection of electrical equipment

Electrical equipment must be protected for safety reasons from external influences and conditions. Enclosures provide the protection of electrical equipment against access to hazardous parts and against solid foreign objects, as well as dust, humidity and water.

The international standard IEC 60 529, the German standard *DIN EN 60 529 / VDE 0470 Part 1 September 2000* with the title

“Degrees of protection provided by enclosures (IP Code)”, form the basis for the determination and designation of the degree of protection.

The degree of protection provided by an enclosure is proven by means of standardized testing methods.

The becoming “aged” of test samples before carrying out the actual type tests are part of the standardized testing methods.

Ageing is made by an more-active increased thermal treatment.

1st characteristic numeral: Protection against foreign solid objects and direct contact		Additional letter		Application
Meaning for the protection of equipment against ingress of solid foreign objects and of persons against access to hazardous parts with (non-protected) back of hand, finger, tool or wire.		Additional letter where the actual protection against access to hazardous parts is higher than that indicated by the 1st characteristic numeral (e.G. IP 20C)		
	Protection against ingress of solid foreign objects ...	Protection against access to hazardous parts with ...	Short form: Protection against access with ...	Symbol
<b>IP 0X</b>	non-protected	non-protected		
<b>IP 1X</b>	solid foreign objects ≥ 50 mm Ø	the back of a hand	<b>A</b>	the back of the hand
<b>IP 2X</b>	solid foreign objects ≥ 12.5 mm Ø	a finger	<b>B</b>	a finger
<b>IP 3X</b>	solid foreign objects ≥ 2.5 mm Ø	a tool ≥ 2.5 mm Ø	<b>C</b>	a tool ≥ 2.5 mm Ø
<b>IP 4X</b>	solid foreign objects ≥ 1 mm Ø	a wire ≥ 1 mm Ø	<b>D</b>	a wire ≥ 1 mm Ø
<b>IP 5X</b>	dust-protected	with any auxiliary equipment (wire)		
<b>IP 6X</b>	dust-tight	contact with any auxiliary equipment (wire)		

##### Meaning of the first characteristic numeral

The first characteristic numeral indicates, to what extent the enclosure provides protection for persons against the access to (affecting of) hazardous parts. This protection is reached, when the penetration into an enclosure of a part of the body or a foreign object, which is held by a person, is prevented or limited. At the same time the enclosure provides protection of equipment against the penetration of solid foreign objects. This is the reason for having two descriptions and two definitions to each first characteristic numeral.

##### Meaning of the second characteristic numeral

The second characteristic numeral indicates the protection of the enclosure against ingress of water with harmful effects on the electrical equipment.

The marking system consists of the code letters **IP** and two following characteristic numerals.

**Example:**  
**IP 6 7**



**2nd characteristic numeral: Protection against ingress of water with harmful effects**

IP X0	IP X1	IP X2	IP X3	IP X4	IP X5	IP X6	IP X7	IP X9
Non-protected	Protection against vertical dripping water	Protected against dripping water, when the housing is tilted up to 15°	Protection for occasional cleaning procedures, not direct spraying of the equipment (spraying water)	Protection for occasional cleaning procedures, not direct spraying of the equipment (splashing water)	Protection of operational processes, not direct spraying of the equipment (water jets)	Protection of operational processes, not direct spraying of the equipment (powerful water jets)	Protection against the effects of temporary immersion in water	Protection against cleaning processes (direct jet) and high water temperatures
	☰	☰	☰	☰	☰☰	☰☰	☰☰	
IP 20								
IP 30	IP 31							
IP 40	IP 41	IP 42	IP 43	IP 44				
				IP 54	IP 55			
					IP 65	IP 66	IP 67	IP 69

**Additional letters to the IP Code**

The IP Code can still be extended by additional letters. Additional letters indicate the degree of protection against access to hazardous parts. Additional letters follow the two characteristic numerals. Additional letters are only used, - if the actual protection against access to hazardous parts is higher than by the first characteristic numeral indicated; or - if only the protection against access to hazardous parts is indicated and the degree of protection against solid foreign objects is not considered. The first characteristic numeral being then replaced by an X. An enclosure shall only be designated with a stated degree of protection indicated by the additional letter if the enclosure also complies with all lower degrees of protection.

## Technical data

### Recommendation for outdoor installations, humid and wet areas and locations

Country-specific requirements have to be observed!

#### 1. Requirement

Protection against ingress of water for all electrical equipment (devices) with the appropriate encapsulation (2nd characteristic numeral)

#### Note for outdoor installation:

#### Requirements of German standard DIN VDE 0100 Part 737 for compliance with IP degree of protection

1.1. Minimum requirement for electrical equipment:



#### „Protected outdoors“

Electrical equipment has to be protected from precipitation (like rain, snow or hail) as well as from direct sunlight.

#### „Non-protected outdoors“

Electrical equipment can be exposed to precipitation or direct sunlight.

With both assembly sites the climatic effects on the installed equipment must be observed, for example, high or low ambient temperatures or condensation.

1.2. Minimum requirements for electrical equipment, that must withstand higher environmental stresses:

#### degree of protection IP X **4**

with **non-direct** jets of water within occasional cleaning procedures, e.g. agriculture



#### degree of protection IP X **5**

with **non-direct** jets of water within operational cleaning procedures, e.g. carwash



#### degree of protection IP X **5** and additional consultation with the manufacturer:

with **direct** jets of water within occasional cleaning procedures of enclosures, e.g. butcher's shop



Country-specific requirements have to be observed!

#### 2. Requirement of German Standard DIN VDE 0100 Part 737

4.1 Electrical equipment must be selected taking into account the external influences to which they may be exposed. Proper operation and the effectiveness of the required degrees of protection must be assured.

Note: Data from the manufacturer!

## Technical data

### Formation of condensed water and retaliatory actions

#### How does condensed water occur in enclosures with a high degree of protection?

Condensed water only forms in enclosures with a higher degree of protection than IP 54 due to temperature difference from inside to outside. Humidity can not evaporate because of the high degree of protection of the enclosure.

System switched on.

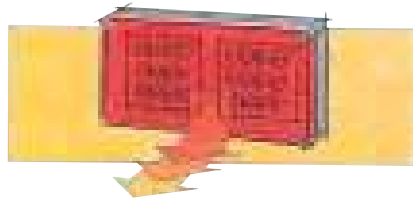

The internal temperature is higher than the external temperature due to the power dissipation of the built-in devices.

System switched on.

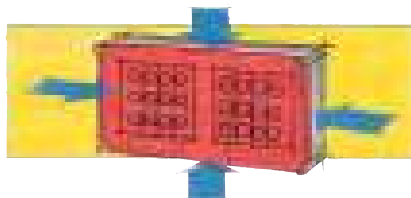

The warm air inside the enclosure attempts to accumulate moisture. This comes from outside through the seal as the enclosures are not gas-tight.

System switched off.



The internal temperature is reduced by cooling down the system e.g. by switching off the loads. The cooler air emits moisture which is collected as condensed water on the cooling inner surfaces.

#### How does condensed water occur in enclosures with a high degree of protection?

Formation of condensed water for **indoor installations:**

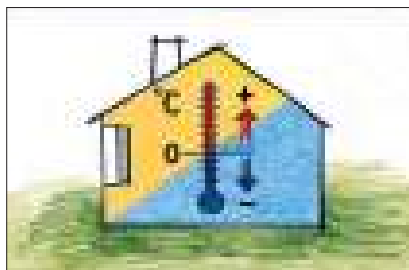

In areas where high levels of air humidity and large temperature fluctuations are expected e.g. in laundry rooms, kitchens, car washes etc.

Formation of condensed water in **protected outdoor installations** (protected against weather influences) **or unprotected outdoor installations:**



Here condensed water can be formed dependent on the weather, high air humidity, direct sunlight and temperature differences compared to the wall.

## Technical data

### Formation of condensed water and retaliatory actions

#### Measure against formation of condensation water

e. g. Cable junction boxes

1. Select the installation site (avoid temperature differences).
2. Open condensation water membrane at the lowest point of the cable junction box (maybe drill hole  $\varnothing$  5 mm).
3. Enable exchange of air via ventilation.



Open condensation water membrane



e.g. Mi Distribution boards

Ventilation flange for vertical mounting on lateral box walls in case of extremely high inside temperature or the risk of water condensation, degree of protection IP 44.



#### Cable entry and ventilation

Combi climate glands





Combi climate glands ensure pressure compensation between enclosure interior and ambient air via an inserted, breathable membrane and ingress of water from outside is prevented.



## Technical data

### International short forms of types of conductors IK code

#### International short forms of types of conductors

r (rigid)				f (flexible)
sol (solid)		s (stranded)		
round conductors 	sector-type conductors 	round conductors 	sector-type conductors 	flexible conductors 
RE (round single)	SE (sector, solid)	RM (round stranded)	SM (sector, stranded)	

#### IK Code Protection against mechanical shock (impact strength)

#### IK Code: Demand energy value [W] in Joules.

The European standard for enclosures EN 50298:98 includes also the IK Code for impact strength. With the DIN EN 50102 (VDE 0470 part of 100) "Degrees of protection by enclosures for electrical operational funds (equipment) against outside mechanical loads (IK Code)", is defined with the identification letters IK.

This standard regulates the methods for the description of the protection of enclosures against outside mechanical loads.

This indicates the degree of protection, which is provided by an enclosure against a mechanical load (demand energy in joules).

HENSEL tests its enclosures and enclosure systems additionally also according to this standard.

#### Classification of the impact strength by the IK Code

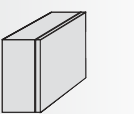
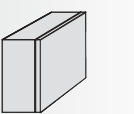
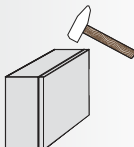
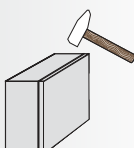
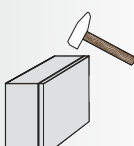
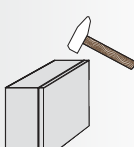
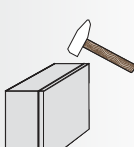
IK Code	[W] in J	
IK00	no protection	
IK01	0,14	
IK02	0,2	
IK03	0,35	
IK04	0,5	
IK05	0,7	

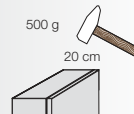
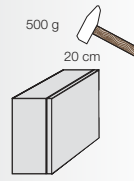
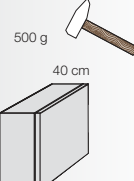
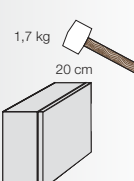
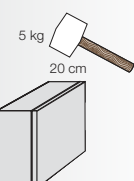
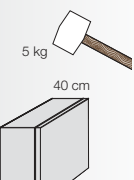
IK Code	[W] in J	
IK06	1	
IK07	2	
IK08	5	
IK09	10	
IK10	20	

## Technical data

### Outside diameter of conventional cable cross-sections Short forms of cables

The outside diameters are average values of different products.

Cable cross-section	NYM	NYY	NYCY NYCWY
mm <sup>2</sup>	mm Ø	mm Ø	mm Ø
1x4	8	9	—
1x6	8.5	10	—
1x10	9.5	10.5	—
1x16	11	12	—
1x25	—	14	—
1x35	—	15	—
1x50	—	16.5	—
1x70	—	18	—
1x95	—	20	—
1x120	—	21	—
1x150	—	23	—
1x185	—	25	—
1x240	—	28	—
1x300	—	30	—
2x1.5	10	12	—
2x2.5	11	13	—
2x4	—	15	—
2x6	—	16	—
2x10	—	18	—
2x16	—	20	—
2x25	—	—	—
2x35	—	—	—
3x1.5	10.5	12.5	13
3x2.5	11	13	14
3x4	13	16	16
3x6	15	17	17
3x10	18	19	18
3x16	20	21	21
3x25	—	26	—
3x35	—	—	—
3x50	—	—	—
3x70	—	—	—
3x95	—	—	—
3x120	—	—	—
3x150	—	—	—
3x185	—	—	—
3x240	—	—	—
3x25/16	—	27	27
3x35/16	—	28	27
3x50/25	—	32	32
3x70/35	—	32-36	36
3x95/50	—	37-41	40
3x120/70	—	42	43
3x150/70	—	46	47
3x185/95	—	52	48-54
3x240/120	—	57-63	60
3x300/150	—	63-69	—

Cable cross-section	NYM	NYY	NYCY NYCWY
mm <sup>2</sup>	mm Ø	mm Ø	mm Ø
4x1.5	11	13.5	14
4x2.5	12.5	14.5	15
4x4	14.5	17.5	17
4x6	16.5	18	18
4x10	18.5	20	20
4x16	23.5	23	23
4x25	28.5	28	28
4x35	32	26-30	29
4x50	—	30-35	34
4x70	—	34-40	37
4x95	—	38-45	42
4x120	—	42-50	47
4x150	—	46-53	52
4x185	—	53-60	60
4x240	—	59-71	70
4x25/16	—	—	30
4x35/16	—	—	30
4x50/25	—	—	34-37
4x70/35	—	—	40
4x95/50	—	—	44.5
4x120/70	—	—	48.5
4x150/70	—	—	53
4x185/95	—	—	—
4x240/120	—	—	—
5x1.5	12	15	15
5x2.5	13.5	16	17
5x4	15.5	16.5	18
5x6	18	19	20
5x10	20	21	—
5x16	26	24	—
5x25	31.5	—	—
7x1.5	13	16	—
7x2.5	14.5	16.5	—
19x1.5	—	22	—
24x1.5	—	25	—

#### Short forms of cables

NYM Light plastic-sheathed cable

NYY Plastic-sheathed cable

NYCY Plastic-sheathed cable with concentric conductor

NYCWY Plastic-sheathed cable with concentric, undulated conductor

## Technical data

### Assignment of cable outside diameters to cable glands Standards

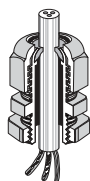

Outside diameter of cables		Cable entry metric
min. mm Ø	max. mm Ø	
3	6.5	AKM/ASS 12
5	10	AKM/ASS 16
6.5	13.5	AKM/ASS 20
10	17	AKM/ASS 25
14	21	AKM/ASS 32
20	28	AKM/ASS 40
25	35	AKM/ASS 50
35	48	AKM/ASS 63
5	10	AFM 16
8	13	AFM 20
11	17	AFM 25
15	21	AFM 32

#### Cable glands AKM/ASS

Degree of protection: IP 66/67/69  
With strain relief and counternut.

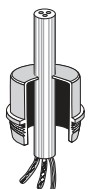

Outside diameter of cables		Cable entry metric
min. mm Ø	max. mm Ø	
4.8	11	ESM 16
6	13	ESM 20
9	17	ESM 25
9	23	ESM 32
17	30	ESM 40

#### Grommets ESM

Degree of protection: IP 55  
Grommets are inserted into knockouts.  
No nut is necessary!

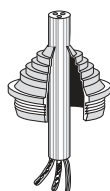

Outside diameter of cables		Cable entry metric
min. mm Ø	max. mm Ø	
3.5	12	STM 16
5	16	STM 20
5	21	STM 25
13	26.5	STM 32
13	34	STM 40

#### Stepped grommets STM

Degree of protection: IP 55  
Stepped grommets are inserted into knock outs.  
No nut is necessary!

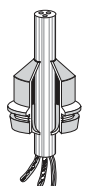

Outside diameter of cables		Cable entry metric
min. mm Ø	max. mm Ø	
5	10	EDK 16
6	13	EDK 20
9	17	EDK 25
8	23	EDK 32
11	30	EDK 40

#### Grommets EDK

Degree of protection: IP 65  
Grommets are inserted into knock outs.  
No nut is necessary!

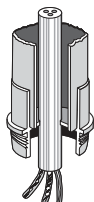

Outside diameter of cables		Cable entry metric
min. mm Ø	max. mm Ø	
Conduit		
M 16		EDR 16
M 20		EDR 20
M 25		EDR 25
M 32		EDR 32
M 40		EDR 40

#### Grommets for conduits EDR

Degree of protection: IP 65  
Grommets for conduits are inserted into knock outs.  
No nut is necessary!

**Hensel cable entries comply with the following standards and regulations:**

- EN 50262  
Metric cable entries for electrical installations
- EN 60423  
Conduits for electrical purposes - Outside diameter of conduits for electrical installations and threads for conduits and fittings
- IEC 60529  
Degrees of protection provided by enclosures (IP-Code)

## Technical data

### Terminal technology

#### PE and N FIXCONNECT® terminal

#### Rated connecting capacity of PE and N terminals

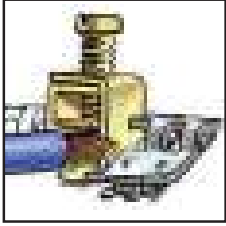
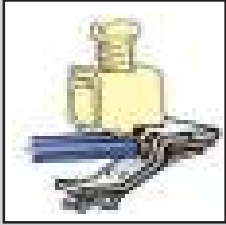
Clamping unit	Corresponding cross-sections/copper			
	max. number	from - to max.	max. number	from - to max.
Screw-type terminal 25 mm <sup>2</sup>				
	1	25 mm <sup>2</sup> , s	1	25 mm <sup>2</sup> , f
	1	16 mm <sup>2</sup> , s	1	16 mm <sup>2</sup> , f
	1	10 mm <sup>2</sup> , sol	1	10 mm <sup>2</sup> , f
	3	6 mm <sup>2</sup> , sol	1	6 mm <sup>2</sup> , f
	3	4 mm <sup>2</sup> , sol	1	4 mm <sup>2</sup> , f
	4	2.5 mm <sup>2</sup> , sol	1	2.5 mm <sup>2</sup> , f
	4	1.5 mm <sup>2</sup> , sol	1	1.5 mm <sup>2</sup> , f
			} Tested as connecting terminal for several conductors of the same cross-sections for using in one circuit	
Plug-in terminal 4 mm <sup>2</sup>				
	1	1.5 - 4 mm <sup>2</sup> , sol	1	1.5 - 4 mm <sup>2</sup> , f
			Without end ferrule; clamping unit has to be opened with a tool when conductor is inserted	

#### Current carrying capacity of the connecting device: 75 A







All terminals are secured against self loosening.

## Technical data





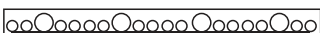



### Terminal technology

#### Terminal equipment and number of conductors to be connected

##### PE terminal for copper conductors

Number of modules	PE terminal	
	 up to 4 mm <sup>2</sup>	 up to 25 mm <sup>2</sup>
3	 4x4 mm <sup>2</sup>	1x25 mm <sup>2</sup>
4.5 6	 4x4 mm <sup>2</sup>	2x25 mm <sup>2</sup>
9	 8x4 mm <sup>2</sup>	2x25 mm <sup>2</sup>
12	 12x4 mm <sup>2</sup>	2x25 mm <sup>2</sup>
18	 16x4 mm <sup>2</sup>	4x25 mm <sup>2</sup>
24 36 (3-row) 48	 24x4 mm <sup>2</sup>	6x25 mm <sup>2</sup>
36 (2-row) 54	 32x4 mm <sup>2</sup>	8x25 mm <sup>2</sup>

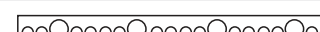
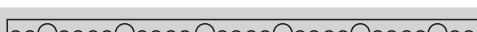
##### N terminal for copper conductors

Number of modules	N terminal		
	 up to 4 mm <sup>2</sup>	 up to 25 mm <sup>2</sup>	 plug-in jumper
3	 4x4 mm <sup>2</sup>	1x25 mm <sup>2</sup>	
4.5 6	 4x4 mm <sup>2</sup>	2x25 mm <sup>2</sup>	
9	 8x4 mm <sup>2</sup>	2x25 mm <sup>2</sup>	
12	 12x4 mm <sup>2</sup>	2x25 mm <sup>2</sup>	
18	 16x4 mm <sup>2</sup>	4x25 mm <sup>2</sup>	
24 36 (3-row) 48	 24x4 mm <sup>2</sup>	6x25 mm <sup>2</sup>	
36 (2-row) 54	 32x4 mm <sup>2</sup>	8x25 mm <sup>2</sup>	

## Technical data

### Preparation of aluminum conductors

#### Connection of aluminum conductors

##### I. Chemical basics

The special conducting characteristics of aluminum can be seen in the fact that the surface of an aluminum conductor is immediately covered in a **non-conducting oxide layer** upon exposure to oxygen.

This characteristic leads to an increase in the temporary resistance between the aluminum conductors and the terminal body.

This can lead to terminal overheating and in the worst case fire.

Despite these special conditions, aluminum conductors can be connected if the terminal used is appropriate and the following conditions are taken into consideration when connecting.

##### II. Special terminal requirements for the connection of aluminum conductors

**The suitability of terminal for connections with aluminum conductors needs to be evaluated and confirmed by the terminal manufacturer.**

1. These terminals will thus meet the requirements for an aligned **electrochemical voltage sequence**. A disintegration of the base material (aluminum) will be prevented.
2. The terminal has an appropriate shape and surface to penetrate the grease layer or a very thin oxide layer on the aluminum conductor upon connection.

##### III. Appropriate preparation and handling of aluminum conductors



1. The non-insulated conductor ends need to have the oxide layer carefully scraped clean using a knife for example. In doing so no files, sand paper or brushes may be used.



2. Immediately after removing the oxide layer, the conductor end needs to be rubbed with an acid and alkali free grease such as technical vaseline and then immediately connected to the terminal. This in turn prevents oxygen from forming a non-conducting oxide layer.



3. Due to the flow tendency in aluminum the terminals need to be tightened before start up and after the first **200 operating hours** (note the appropriate torque).

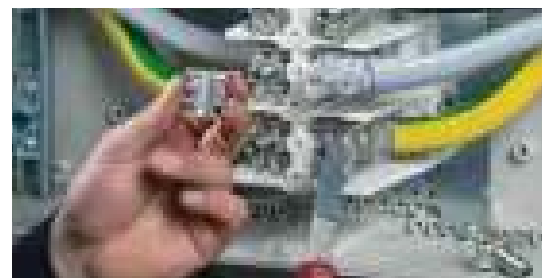

4. The steps listed above need to be repeated if the conductor is removed and re-connected. I.e. the conductor has to be scraped again, greased and immediately connected, because it will be connected at a different position.

## Technical data

### Tested quality

#### Test for dust protection

indicated by the first characteristic numerals 5 and 6 in accordance with IEC 60529



#### Test for protection against water

in accordance with IEC 60529 indicated by the characteristic numeral

7: temporary immersion

6: with powerful water jets,

4: splashing water

1: drip box



#### Test with vertical hammer

in accordance with IEC 60068-2-75

#### Test of screw-type clamping units

against loosening in accordance with IEC 60998-2-1



#### Glow wire test

in accordance with IEC 60695-2-11



#### Tests in the climatic test cabinet

according to IEC 60068-1  
Resistance of materials against certain environmental influences such as heat, cold, humidity

#### Environmental testing -

Salt mist test in accordance with IEC 60068-2-11



## Technical data

### Definition of terms

#### Definition of Terms

Rated values for setting up low-voltage switchgear are given in the standard IEC 61 439-1

#### Rated voltage ( $U_n$ )

highest nominal value of the a.c. (r.m.s.) or d.c. voltage, declared by the assembly manufacturer, to which the main circuit(s) of the assembly is (are) designed to be connected.

#### Rated operational voltage ( $U_o$ ) (of a circuit of an assembly)

value of voltage, declared by the assembly manufacturer, which combined with the rated current determines its application.

#### Rated insulation voltage ( $U_i$ )

r.m.s. withstand voltage value, assigned by the assembly manufacturer to the equipment or to a part of it, characterising the specified (long-term) withstand capability of the insulation.

#### Rated impulse voltage ( $U_{imp}$ )

impulse withstand voltage value, declared by the assembly manufacturer, characterising the specified withstand capability of the insulation against transient overvoltages.

#### Rated current ( $I_n$ )

value of current, declared by the assembly manufacturer taking into consideration the ratings of the components, their disposition and application, which can be carried without the temperature-rise of various parts of the assembly exceeding specified limits under specified conditions.

#### Prospective short circuit current ( $I_{cp}$ )

current which flows when the supply conductors to the circuit are short-circuited by a conductor of negligible impedance located as near as practicable to the supply terminals of the assembly.

#### Rated peak withstand current ( $I_{pk}$ )

value of peak short-circuit current, declared by the assembly manufacturer, that can be withstood under specified conditions.

#### Rated short-time withstand current ( $I_{cw}$ )

r.m.s value of short-time current, declared by the assembly manufacturer, that can be carried without damage under specified conditions, defined in terms of a current and time.

#### Rated current of the assembly ( $I_{nA}$ )

The rated current of the assembly is the smaller of:

- the sum of the rated currents of the incoming circuits within the assembly operated in parallel;
- the total current which the main busbar is capable of distributing in the particular assembly arrangement.

This current shall be carried without the temperature rise of the individual parts exceeding the limits specified in the standard.

#### Rated current of a circuit ( $I_{nc}$ )

The rated current of a circuit is stated by the assembly manufacturer, taking into consideration the ratings of the devices within the circuit, their disposition and application. This current shall be carried without the temperature rise of the various parts of the assembly exceeding the limits specified in the standard when the circuit is loaded alone.

#### Rated diversity factor (RDF)

per unit value of the rated current, assigned by the assembly manufacturer, to which outgoing circuits of an assembly can be continuously and simultaneously loaded taking into account the mutual thermal influences.

**Technical data**  
**EC Declaration of conformity**



**Erklärung der EG-Konformität**  
**Declaration of EC Conformity**

**HENSEL**

**Nr./No. K-2016-12**

Das Produkt / Typ  
 The product / Type

FX 0402, FX 0404, FX 0504, FX 0506,  
 FX 1606, FX 1608, FX 1610, FX 1616  
 FX 9025, FX 9105, FX 9255, FX 9259  
 FX 7045, 7105, FX 7165  
 FX 6505

Hersteller  
 Manufacturer

Gustav Hensel GmbH & Co. KG  
 Gustav-Hensel-Strasse 6  
 57368 Lennestadt

Beschreibung  
 Description

Kabelzweigkästen mit Funktionserhalt E30-E90  
 cable junction boxes tested for intrinsic fire resistance E30-E90

auf das sich diese Erklärung bezieht, stimmt mit folgenden Normen oder normativen Dokumenten überein:  
 to which this declaration relates is in conformity with the following standard(s) or normative document(s):

Norm  
 Standard

DIN EN 60670-22  
 EN 60670-22  
 IEC 60670-22  
 DIN 4102-12

und entspricht den Bestimmungen der folgenden EG-Richtlinie(n):  
 and is in accordance with the provisions of the following EC-directive(s)

Niederspannungs-Richtlinie 2014/35/EG  
 Low voltage directive 2014/35/EU

RoHS Richtlinie 2011/65/EG  
 RoHS directive 2011/65/EU

Diese Konformitätserklärung entspricht der Europäischen Norm EN 17050-1 „Allgemeine Anforderungen für Konformitätserklärungen von Anbietern“. Diese Erklärung gilt weltweit als Erklärung des Herstellers zur Übereinstimmung mit den oben genannten internationalen und nationalen Normen.

This Declaration of Conformity is suitable to the European Standard EN 17050-1 „General requirements for supplier's declaration of conformity“. The declaration is world-wide valid as the manufacturer's declaration of compliance with the requirements of the a.m. national and international standards.

Jahr der Anbringung der CE-Kennzeichnung  
 Year of affixing CE-Marking

2015

Ausstellungsdatum  
 Date of issue

22.04.2016

Gustav Hensel GmbH & Co. KG  
 O. Gölz  
 - Technische Geschäftsführung -  
 - Technical Managing Director -

**Erklärung der EG-Konformität**  
**Declaration of EC Conformity**

**Nr./No. K-2016-19**

Das Produkt / Typ  
 The product / Type

K 0102, K 0202, K 0204, K 0402, K 0501, K 0501, K 0501, K 0501, K 0501, K 0501

Hersteller  
 Manufacturer

Gustav Hensel GmbH & Co. KG  
 Gustav-Hensel-Strasse 6  
 57368 Lennestadt

Beschreibung  
 Description

Leuchtdiode für Einphasen- und Dreiphasen-Netze  
 LED light source for single and three phase networks

Norm  
 Standard

DIN EN 60320  
 IEC 60320

Das Konformitätsverfahren entspricht der Europäischen Norm EN 17050-1 „Allgemeine Anforderungen für Konformitätserklärungen von Anbietern“. Diese Erklärung gilt weltweit als Erklärung des Herstellers zur Übereinstimmung mit den oben genannten internationalen und nationalen Normen.

This Declaration of Conformity is suitable to the European Standard EN 17050-1 „General requirements for supplier's declaration of conformity“. The declaration is world-wide valid as the manufacturer's declaration of compliance with the requirements of the a.m. national and international standards.

Jahr der Anbringung der CE-Kennzeichnung  
 Year of affixing CE-Marking

2016

Ausstellungsdatum  
 Date of issue

12.10.2016

Gustav Hensel GmbH & Co. KG  
 O. Gölz  
 - Technische Geschäftsführung -  
 - Technical Managing Director -

**Erklärung der EG-Konformität**  
**Declaration of EC Conformity**

**Nr./No. K-2016-7**

Das Produkt / Typ  
 The product / Type

MR-Hauslein, Typ M1  
 MR-Hauslein, Typ M1

Hersteller  
 Manufacturer

Gustav Hensel GmbH & Co. KG  
 Gustav-Hensel-Strasse 6  
 57368 Lennestadt

Beschreibung  
 Description

Niederstromversorgungs-Schutzgruppenautomaten „SPC“  
 Low voltage supply protection and switching automatic „SPC“

Das Konformitätsverfahren entspricht der Europäischen Norm EN 17050-1 „Allgemeine Anforderungen für Konformitätserklärungen von Anbietern“. Diese Erklärung gilt weltweit als Erklärung des Herstellers zur Übereinstimmung mit den oben genannten internationalen und nationalen Normen.

This Declaration of Conformity is suitable to the European Standard EN 17050-1 „General requirements for supplier's declaration of conformity“. The declaration is world-wide valid as the manufacturer's declaration of compliance with the requirements of the a.m. national and international standards.

Jahr der Anbringung der CE-Kennzeichnung  
 Year of affixing CE-Marking

2012

Ausstellungsdatum  
 Date of issue

22.04.2016

Gustav Hensel GmbH & Co. KG  
 O. Gölz  
 - Technische Geschäftsführung -  
 - Technical Managing Director -



The current status of EC Declarations of conformity is available on the Internet at [www.hensel-electric.de](http://www.hensel-electric.de) -> Products

Technical information  
 Technical data



## Index of types

Types	Pages
<b>A</b>	
AKM 12	404
AKM 16	404
AKM 20	404
AKM 25	404
AKM 32	405
AKM 40	405
AKM 50	405
AKM 63	405
AKMF 20	101
AKMF 25	101
AKMF 32	101
AKMF 40	101
AKS 9	417
AKS 11	417
AKS 13,5	417
AKS 16	417
AKS 21	417
AKS 29	418
AKS 36	418
AKS 42	418
AKS 48	418
AS 12	215, 268, 345
AS 18	215, 268, 345
ASS 12	406
ASS 16	406
ASS 20	406
ASS 25	406
ASS 32	407
ASS 40	407

Types	Pages
ASS 50	407
ASS 63	407
<b>B</b>	
BE 44	277, 353
BM 20G	278, 354, 414
BM 40G	278, 354, 414
<b>D</b>	
DAE 12	268, 345
DE 9220	114
DE 9221	115
DE 9225	114
DE 9226	115
DE 9320	109
DE 9321	110
DE 9325	108
DE 9326	110
DE 9330	109
DE 9331	111
DE 9340	109
DE 9341	110
DE 9345	108
DE 9346	110
DE 9350	109
DE 9351	111
DE MB 10	116
DK 0200 G	27
DK 0200 R	39

Types	Pages
DK 0202 G	19
DK 0202 R	37
DK 0400 G	27
DK 0400 R	39
DK 0402 A	30
DK 0402 G	19
DK 0402 R	37
DK 0404 G	19
DK 0404 R	37
DK 0600 G	27
DK 0604 A	30
DK 0604 G	20
DK 0604 R	38
DK 0606 G	20
DK 1000 G	27
DK 1006 G	20
DK 1010 G	21
DK 1600 G	28
DK 1610 G	22
DK 1616 G	22
DK 2500 G	28
DK 2516 A	31
DK 2524 S	42
DK 2525 G	22
DK 3500 G	28
DK 3525 S	42
DK 3534 S	43
DK 3535 G	23
DK 5000 G	28
DK 5035 S	43
DK 5054 G	23



## Index of types

Types	Pages	Types	Pages	Types	Pages
FP 0121	246	FP 0461	239	FP AP 20	267
FP 0140	237	FP 0471	242	FP AP 30	267
FP 0141	237	FP 1100	262	FP AP 40	267
FP 0150	240	FP 1101	260	FP BF 18	277
FP 0151	240	FP 1105	254	FP BF 27	277
FP 0210	243	FP 1106	256	FP BF 36	277
FP 0211	244	FP 1107	256	FP BZ 13	266
FP 0230	246	FP 1108	250	FP CB 210	264
FP 0231	247	FP 1109	250	FP DB 27	279
FP 0240	237	FP 1211	253, 261	FP DB 36	279
FP 0241	238	FP 1215	254	FP DS 02	265
FP 0250	240	FP 1216	257	FP FC 24	269
FP 0251	241	FP 1217	257	FP FC 36	269
FP 0310	244	FP 1218	251	FP FC 051	270
FP 0311	244	FP 1219	250	FP FC 54	269, 270
FP 0330	247	FP 1249	260	FP FG 200	275
FP 0331	247	FP 1315	254	FP FG 222	275
FP 0340	238	FP 1316	258	FP FG 272	276
FP 0341	238	FP 1317	258	FP FG 273	276
FP 0350	241	FP 1318	251	FP FG 282	276
FP 0351	241	FP 1319	251	FP FG 300	276
FP 0400	245	FP 1349	260	FP FG 331	276
FP 0401	245	FP 1406	259	FP FM 225	275
FP 0411	245	FP 1408	252	FP FM 232	275
FP 0420	248	FP 1409	252	FP FM 240	275
FP 0421	248	FP 1415	255	FP FM 263	275
FP 0431	248	FP 1417	259	FP GS 27	276
FP 0440	239	FP 1418	252	FP GV 10	280
FP 0441	239	FP 1439	261	FP MP 10	266
FP 0450	242	FP AL 40	281	FP MP 20	266
FP 0451	242	FP AP 10	267	FP MP 30	266

## Index of types

Types	Pages	Types	Pages	Types	Pages
FP MP 40	266	<b>G</b>		KBM 40	410
FP MS 1	281			KBS 20	411
FP PL 2	267			KBS 25	411
FP PL 3	280			KBS 32	412
FP TS 1	280			KBS 40	412
FP TS 2	280			KF 0200 B	65
FP TS 27	265			KF 0200 C	72
FP TS 36	265			KF 0200 G	56
FP TS 54	265			KF 0200 H	69
FP TW 1	280			<b>K</b>	
FP TW 2	280	KF 0202 G	50		
FP TW 3	280	KF 0400 B	65		
FP TW 4	280	KF 0400 C	72		
FP TW 18	268	KF 0400 G	56		
FP TW 27	268	KF 0400 H	69		
FP TW 36	268	KF 0402 B	59		
FP VM 27	274	KF 0402 G	50		
FP VM 36	274	KF 0404 B	59		
FP VP 18	272	KF 0404 G	50		
FP VP 27	272	KF 0600 B	65		
FP VP 36	272	KF 0600 C	72		
FP VS 10	273	KF 0600 G	56		
FP VS 20	273	KF 0600 H	69		
FP VS 30	273	KF 0604 B	60		
FP VS 40	273	KF 0604 G	51		
FP WT 1	272	KF 0606 B	60		
FP ZE 272	276	KF 0606 G	51		
FP ZR 20	265	KF 1000 B	66		
FP ZR 30	265	KF 1000 C	73		
FP ZR 40	265	KF 1000 G	57		
		KBM 20	409	KF 1000 H	70
		KBM 25	409		
		KBM 32	410		

## Index of types

Types	Pages	Types	Pages	Types	Pages
KF 1006 B	61	KF 5050 G	55	KV 1518 M	174
KF 1006 G	52	KG 9001	379	KV 1603	146
KF 1010 B	61	KG 9001 IN	381	KV 1604	148
KF 1010 G	52	KG 9002	379	KV 1606	150
KF 1600 B	66	KG 9002 IN	381	KV 1609	152
KF 1600 C	73	KG 9003	380	KV 1612	154
KF 1600 G	57	KG 9003 IN	382	KV 1612 M	173
KF 1600 H	70	KG MP 01	388	KV 1618	156
KF 1610 B	62	KG MP 02	388	KV 1618 M	175
KF 1610 G	53	KG MP 03	388	KV 1712	193
KF 1616 B	62	KG PN 01	388	KV 1718	193
KF 1616 G	53	KG PN 02	388	KV 2524	158
KF 2500 B	66	KG PN 03	388	KV 2524 M	177
KF 2500 C	73	KG TS 01	388	KV 2536	160
KF 2500 G	57	KG TS 02	388	KV 2536 M	178
KF 2500 H	70	KG TS 03	388	KV 2624	158
KF 2525 B	63	KHR 01	112, 116, 123, 415	KV 2624 M	177
KF 2525 G	54	KHR 02	112, 116, 123, 415	KV 2636	160
KF 3500 B	67	KKL 25	346	KV 2636 M	179
KF 3500 C	74	KKL 34	271, 349	KV 2724	194
KF 3500 G	58	KKL 48	271, 349	KV 2736	194
KF 3500 H	71	KKL 54	271, 349	KV 3536	162
KF 3535 B	63	KST 70	415	KV 3536 M	181
KF 3535 G	54	KST 82	126, 353	KV 3554	166
KF 3550 A	31	KV 1503	145	KV 3554 M	184
KF 5000 B	67	KV 1504	147	KV 3636	162
KF 5000 C	74	KV 1506	149	KV 3636 M	181
KF 5000 G	58	KV 1509	151	KV 3654	166
KF 5000 H	71	KV 1512	154	KV 3654 M	185
KF 5050 A	32	KV 1512 M	173	KV 3736	194
KF 5050 B	64	KV 1518	156	KV 3754	195

## Index of types

Types	Pages	Types	Pages	Types	Pages
KV 4548	164	KV 8354	165	KV 9354	165
KV 4548 M	183	KV 8354 M	184	KV 9354 M	184
KV 4648	164	KV 8448	163	KV 9440	198
KV 4648 M	183	KV 8448 G	206	KV 9440 M	202
KV 4748	195	KV 8448 M	182	KV 9448	163
KV 6103	168	KV 9103	145	KV 9448 M	182
KV 6104	169	KV 9104	147	KV EB 03	214
KV 6106	170	KV 9106	149	KV EB 04	214
KV 6109	171	KV 9109	151	KV EB 06	214
KV 7103	168	KV 9112	153	KV EB 09	214
KV 7104	169	KV 9112 M	172	KV EB 12	214
KV 7106	170	KV 9118	155	KV EB 18	214
KV 7109	171	KV 9118 M	174	KV EB 26	214
KV 8103	145	KV 9220	197	KV ES 1	215
KV 8104	147	KV 9220 M	201	KV ES 2	215
KV 8106	149	KV 9224	157	KV ES 3	215
KV 8109	151	KV 9224 M	176	KV FC 03	212
KV 8112	153	KV 9230	197	KV FC 04	212
KV 8112 G	205	KV 9230 M	201	KV FC 06	212
KV 8112 M	172	KV 9236	159	KV FC 09	212
KV 8118	155	KV 9236 M	178	KV FC 12	212
KV 8118 G	205	KV 9330	198	KV FC 18	213
KV 8118 M	174	KV 9330 M	202	KV FC 24	213
KV 8224	157	KV 9331	208	KV FC 36	213
KV 8224 G	205	KV 9336	161	KV PC 6103	187
KV 8224 M	176	KV 9336 M	180	KV PC 6104	188
KV 8236	159	KV 9337	210	KV PC 6106	188
KV 8236 G	206	KV 9338	210	KV PC 6109	189
KV 8236 M	178	KV 9339	210	KV PC 9103	187
KV 8336	161	KV 9350	199	KV PC 9104	187
KV 8336 M	180	KV 9350 M	203	KV PC 9106	188

## Index of types

Types	Pages	Types	Pages	Types	Pages
KV PC 9109	189	Mi 0400	312	Mi 1440	328
KV PC 9112	190	Mi 0401	315	Mi 1443	331
KV PC 9224	190	Mi 0410	313	Mi 1444	326
KV PC 9336	191	Mi 0411	316	Mi 1445	331
KV PC 9448	191	Mi 0600	313	Mi 1446	334
KV PL 2	215	Mi 0601	316	Mi 1448	324
KV PL 3	215	Mi 0800	313	Mi 1449	337
		Mi 0801	316	Mi 1455	328, 334
		Mi 1109	323	Mi 1456	324
		Mi 1111	326	Mi 1683	329, 335
		Mi 1112	323	Mi 1684	325
		Mi 1115	327	Mi 1884	325
		Mi 1117	330	Mi 1885	329, 335
		Mi 1118	333	Mi 9100	317
		Mi 1119	336	Mi 9101	320
		Mi 1220	324	Mi 9200	317
		Mi 1221	333	Mi 9201	320
		Mi 1222	326	Mi 9210	317
		Mi 1224	323	Mi 9211	320
		Mi 1225	327	Mi 9300	318
		Mi 1226	327	Mi 9301	320
		Mi 1227	330	Mi 9310	318
		Mi 1228	333	Mi 9311	321
		Mi 1229	336	Mi 9400	318
		Mi 1281	332	Mi 9401	321
		Mi 1333	326	Mi 9410	319
		Mi 1335	328	Mi 9411	321
		Mi 1336	324	Mi AL 40	125, 359
		Mi 1337	330	Mi BE	350
		Mi 1338	334	Mi BF 44	353
		Mi 1339	336	Mi BS 6	358

### L

Lackstift RAL 7016	281
LDM 25 B	122
LDM 25 G	122
LDM 32 B	122
LDM 32 G	122

### M

Mi 0100	311
Mi 0101	314
Mi 0200	311
Mi 0201	314
Mi 0210	311
Mi 0211	314
Mi 0220	312
Mi 0221	314
Mi 0300	312
Mi 0301	315
Mi 0310	312
Mi 0311	315

## Index of types

Types	Pages
Mi BS 12	358
Mi BZ 11	343
Mi BZ 13	343
Mi CB 10	339
Mi DB 01	279, 355
Mi DB 15	355
Mi DB 30	355
Mi DR 04	356, 391
Mi DS 25	341
Mi DS 50	341
Mi DV 01	356, 391
Mi EP 01	344
Mi EP 02	344
Mi EP 03	344
Mi EP 04	344
Mi FM 15	351
Mi FM 20	351
Mi FM 25	351
Mi FM 32	351
Mi FM 40	125, 351
Mi FM 50	125, 352
Mi FM 60	125, 352
Mi FM 63	125, 352
Mi FP 15	351
Mi FP 20	351
Mi FP 30	353
Mi FP 38	352
Mi FP 70	125, 352
Mi FP 72	125, 352
Mi FP 82	126, 352
Mi GS 30	353

Types	Pages
Mi KL 6	358
Mi KL 12	358
Mi MP 1	342, 390
Mi MP 2	342, 390
Mi MP 3	342, 390
Mi MP 4	342, 390
Mi MP 8	342
Mi MS 2	359
Mi PL 2	356, 391
Mi SA 2	126, 359
Mi SK 01	358
Mi SN 4	356, 391
Mi SR 4	356, 391
Mi TS 15	341, 389
Mi TS 30	341, 389
Mi TS 45	341, 389
Mi TS 60	341, 389
Mi WD 2	350
Mi WT 1	350
Mi ZE 62	126, 353
Mi ZR 4	340, 392
Mi ZR 8	340
Mi ZS 11	356, 391
Mi ZS 12	356, 391
Mi ZS 20	357, 392
Mi ZS 30	392
Mi ZS 40	357, 392
Mi ZS 60	357, 392
MV FP 66	415
MX 0101	359
MX 0105	360

Types	Pages
MX 0111	360
MX 0112	359

## N

NZ KL 54	358
----------	-----

## P

PLS 06	124
--------	-----

## R

Varnishing pen RAL 7016	360
RK 0203 T	45
RK 0205 T	45
RK 0207 T	46
RK 0405 T	46
RK 0610 T	47
RK 0612 T	47
RK 0614 T	47
RK 1019 T	48
RK 1024 T	48

## S

STM 16	401
STM 20	401
STM 25	401
STM 32	401

## Index of types

Types	Pages	Types	Pages	Types	Pages
STM 40	401				

### U

---

US 1	280
------	-----

### V

---

VSB 13	413
--------	-----

VSB 21	413
--------	-----

### W

---

WP 0202 B	81
-----------	----

WP 0202 G	77
-----------	----

WP 0402 B	81
-----------	----

WP 0402 G	77
-----------	----

WP 0404 B	82
-----------	----

WP 0404 G	78
-----------	----

WP 0604 B	82
-----------	----

WP 0604 G	78
-----------	----

WP 0606 B	83
-----------	----

WP 0606 G	79
-----------	----

WP 1006 B	83
-----------	----

WP 1006 G	79
-----------	----

WP 1010 B	84
-----------	----

WP 1010 G	80
-----------	----





## Meaning of icons

### Area of application



"weatherproof",  
for outdoor installation

### Intrinsic fire resistance and insulation integrity



E30/E60/E90



E30



PH120

### Degree of protection



IP 44



IP 54



IP 55



IP 55  
using ESM grommets



IP 65



IP 65 with Nema 4X  
classification for  
UL/CSA approval



IP 66



IP 66/67



IP 69

### Protection class



II, total insulated

### Colour



grey RAL 7035



orange RAL 2003



**Gustav Hensel GmbH & Co. KG**  
**Industrial Electrical Power Distribution Systems**

Gustav-Hensel-Straße 6  
D-57368 Lennestadt  
Germany  
P.O. Box 1461  
D-57344 Lennestadt, Germany

Phone: +49 (0)27 23/609-0  
Fax: +49 (0)27 23/600 52  
E-Mail: [info@hensel-electric.de](mailto:info@hensel-electric.de)  
[www.hensel-electric.de](http://www.hensel-electric.de)