

HM-MCP-GLASS-UL



General

The HM-MCP-GLASS-UL is an addressable manual break glass call point which, as a simple rotary decade, switch at the rear of the unit for addressing.

A specialist test key may be inserted into the bottom of the unit to lower the glass and release the micro-switch – enabling a complete functionality test.

The HM-MCP-GLASS-UL call point is designed to provide a manual alarm interface to Morley IAS's fire alarm control panel.

Installation efficiency and compliance with the latest standards are at the heart of the call point range.



HM-MCP-GLASS-UL

LED Status

The LED status is controlled by the fire panel and shows blinking RED each time the device is polled, or continuous RED to indicate fire detection.

Connection Details

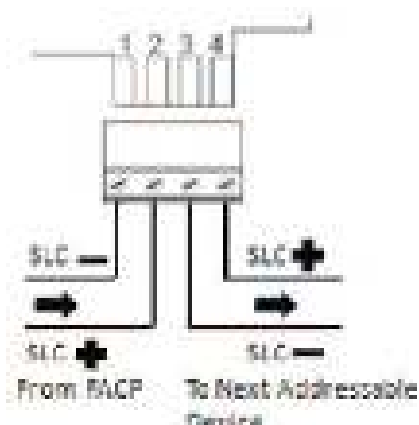

Dimensions

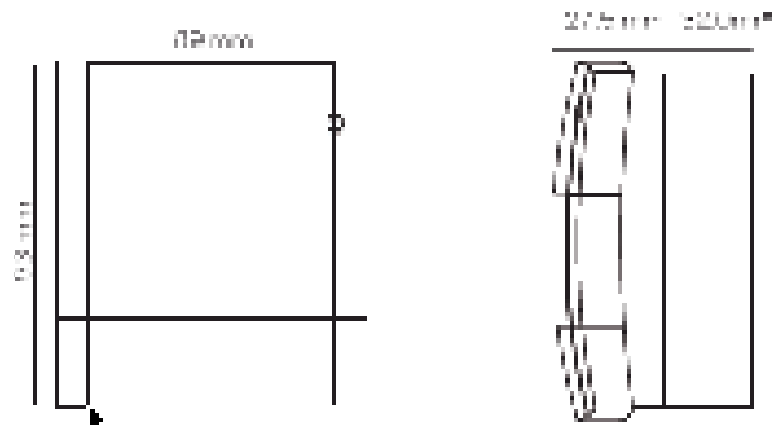

FEATURES & BENEFITS

- Innovative “Plug and Play” installation concept
- Analogue addressable communications
- Integral LED

HM-MCP-GLASS-UL Technical Specifications

Mechanical Specifications

PARAMETER	SPECIFICATION
Dimensions	<ul style="list-style-type: none">• Semi-flush mounting: 89 x 93 x 27.5 (WxHxD)• Surface mounting: 89 x 93 x 59.5 (WxHxD)
Weight	110g (3.8 oz.)
IP Rating	IP24D
Operating Temperature	0°C to 49°C (32°F – 120°F)
Relative Humidity	10% - 93% non-condensing

Electrical Specifications

PARAMETER	SPECIFICATION
Operating Voltage	15V to 32Vdc max
Current Consumption	Quiescent (without isolator) 385µA Alarm Current: 7.8 mA

Optional Accessories

PART CODE	DESCRIPTION
PS230	Pack of 10 resettable elements
MUS041W	Manual call point back box
MUS156	Pack of 10 glass elements
SC070	Pack of 10 test keys

Agency Listings and Approvals

Listing and approval below apply to the modules specified in this. In some cases, certain modules may not be listed by certain approval agencies, or listing may be in process. Consult factory for latest listing status.

- **UL Listed:** S36215

Product Line Information

HM-MCP-GLASS-UL: Addressable break glass manual call point

Honeywell Building Technologies ASEAN

Level 25, UOA Corp Tower B, Avenue 10
The Vertical, Bangsar South City
59200, Kuala Lumpur, Malaysia
Email: Buildings.ASEAN@Honeywell.com

Honeywell Building Technologies META

Emaar Business Park, Building 2, 2nd Floor
Sheikh Zayed Road
P.O.Box 232362, Dubai, U.A.E.
Phone: +971 4 4505 847

Honeywell Building Technologies India

Unitech Trade Centre, 5th Floor
Sector – 43, Block C, Sushant Lok Phase – 1
Gurgaon – 122002, Haryana, India
Email: HoneywellSecurity&Fire@Honeywell.com
Toll Free: 1-800-103-0339
www.honeywell.com

HM-MCP-GLASS-UL | Rev 01 | 08/19
© 2019 Honeywell International Inc.



HM-DISO-UL

General

The HM-DISO-UL Fault Isolator Module is used with the fire alarm control panels (FACPs) to protect the system against wire-to-wire short circuits on the SLC loop. The HM-DISO-UL should be placed between each device on the SLC loop to isolate a short circuit problem between the modules. It is required for true Style 7 operation, so that other devices can continue to operate normally in the event of a short circuit on the SLC.

Application

The Fault Isolator Modules should be spaced between groups of sensors in a loop to protect the rest of the loop. The HM-DISO-UL supports a maximum of 25 devices in between isolators.



HM-DISO-UL

FEATURES & BENEFITS

- Powered by SLC loop directly, no external power required
- Mounts in standard junction boxes (4.0"/10.16 cm square, 2.125"/5.398 cm deep)
- Integral LED blinks to indicate normal condition and illuminates steady when short circuit condition is detected
- High noise (EMF/RFI) immunity

HM-DISO-UL Technical Specifications

SPECIFICATIONS	
Operating voltage	15 – 32 VDC (peak)
Maximum current upon activation due to short circuit	Refer to the manual for the main FACP
Standby current	450 μ A maximum; HM-DISO-UL is not isolated through a closed relay
Temperature range	32°F to 120°F (0°C to 49°C)
Relative humidity	10% to 93%
Weight	5 oz. (150 grams)
Dimensions	4.5"H x 4.5"W x 0.25" D (11.43 cm H x 11.43 cm W x 0.635 cm D)

Construction

The face plate is made of off-white plastic. Module includes yellow LED indicator that pulses to indicate normal conditions and illuminates steady when a short is detected.

Operation

The circuit is automatically opened when the voltage line drops below four volts. Fault Isolator Modules should be spaced between groups of addressable devices (maximum 25), in a loop that protects the rest of the loop. If a short occurs between any two isolators, then both isolators immediately switch to an open circuit state and isolate the groups of sensors between them. The remaining units on the loop continue to fully operate.

The HM-DISO-UL Fault Isolator Module automatically restores the shorted portion of the communications loop to normal.

Installation

- Mount on a standard junction box (4.0"/10.16 cm square) which is at least 2.125"/5.398 cm deep
- Terminal screws are provided for "in and out" wiring
- Installation instructions are provided with each module
- Surface mount box available

Honeywell Building Technologies ASEAN

Level 25, UOA Corp Tower B, Avenue 10
The Vertical, Bangsar South City
59200, Kuala Lumpur, Malaysia
Email: Buildings.ASEAN@Honeywell.com

Honeywell Building Technologies India

Unitech Trade Centre, 5th Floor
Sector – 43, Block C, Sushant Lok Phase – 1
Gurgaon – 122002, Haryana, India
Email: HoneywellSecurity&Fire@Honeywell.com
Toll Free: 1-800-103-0339
www.honeywell.com

Engineering Specifications

Fault Isolator Modules shall be provided to automatically isolate wire-to-wire short circuits on an SLC loop. The Fault Isolator Module limits the number of modules or detectors that may be rendered inoperative by a short circuit fault on the SLC Loop. If a wire-to-wire short occurs, the Fault Isolator Module automatically disconnects the SLC loop. When the short circuit condition is corrected, the Fault Isolator Module automatically reconnects the isolated section of the SLC loop. The Fault Isolator Module doesn't require any address, as operations switch to automatic mode. Replacing or resetting the Fault Isolator Module is not required, after operating normally. The Fault Isolator Module shall mount in a standard 4" (10.16 cm) deep electrical box, in a surface mounted backbox, or in the Fire Alarm Control Panel. It provides a single LED that flashes when the Isolator is operational and illuminates steadily to indicate that a short circuit condition has been detected and isolated.

Agency Listings and Approvals

Listing and approval below apply to the modules specified in this. In some cases, certain modules may not be listed by certain approval agencies, or listing may be in process. Consult factory for latest listing status.

- **UL Listed:** S35595

Product Line Information

HM-DISO-UL	Isolator module
SMB500	Optional surface-mount backbox

Honeywell Building Technologies META

Emaar Business Park, Building 2, 2nd Floor
Sheikh Zayed Road
P.O.Box 232362, Dubai, U.A.E.
Phone: +971 4 4505 847

ExitPoint™

Directional Sounder with Voice Messaging



Audio/Visual Devices

General

The *ExitPoint™ Directional Sounder* has an integral audio amplifier that produces a pulsating sound consisting of broadband low, mid, and high range sounds. The broadband noise makes it possible to determine the location of the sound. There are four pulse patterns that can be used to create an egress pathway out of a building and to mark perimeter exits. In addition to the broadband noise, the sounder is capable of playing an alert message in the form of a recorded voice message or other audible signals. These messages will instruct the occupants of what action to take as they approach the directional sounder, and will allow them to react quickly and confidently when the sounder is activated. Fifteen different language combinations are available to instruct occupants that they are nearing an exit, a stairway up, a stairway down, or an area of refuge. The directional sounder also incorporates an optional disable feature for use in conjunction with a control module or heat sensor.

The directional sounder features a number of field selectable power settings including high, medium-high, medium-low, and low. Installation ease and pleasing aesthetics are achieved by a low profile compact design, and by the ability to flush mount in a 4" x 4" x 2¼" back-box.

ExitPoint directional sounders, fitted in addition to normal building evacuation sounders, draw people to evacuation routes in both good and poor visibility. The directional sounder can be used in a wide range of building applications. Trials consistently have shown an improvement of up to 75 percent in evacuation times in smoke and up to 35 percent without smoke. The 2007 Edition of NFPA 72 now provides installation and maintenance guidelines on directional sounders.

Features

- Listed to UL 464 (indoor applications only)
- Five field-selectable power settings
- Four field-selectable routing evacuation patterns
- Constructed to be effective in unfamiliar surroundings or poor visibility
- Designed to work in open areas, corridors, or stairs
- Fifteen different language selections available
- Reduces evacuation times by as much as 75 percent
- Optional disable feature for use in conjunction with a control module or heat sensor
- Low profile, compact design

Specifications

ELECTRICAL SPECIFICATIONS

Voltage Input: Regulated 24 Volts

Operating Voltage Range: 16 to 33 Volts

Operating Temperature: 32°F to 120°F (0°C to 49°C)

Power Setting: High, medium-high, medium, medium-low, low

MECHANICAL SPECIFICATIONS

Input Terminals: 12-24 AWG

Speaker Size: 4" (101 mm)

Grille Size: 4 7/8" (127 mm)



7044pho1.jpg

Additional Tone Selection

Switch Position 5 Setting	Switch Position 6 Setting	Sound Output
On	On	Area of Refuge
On	Off	Upstairs
Off	On	Downstairs
Off	Off	Exit Here

Enable/Disable Selection

Switch Position 4 Setting	Terminals 3 & 4	Sound Output
On	Open	Disabled
On	Closed	Enabled
Off	Open	Enabled
Off	Closed	Disabled

Power Setting Guide

DIP Switch Position 1 Setting	DIP Switch Position 2 Setting	DIP Switch Position 3 Setting	Power Setting
Off	Off	Off	High
On	Off	Off	Med-High
Off	On	Off	Med
Off	Off	On	Med-Low
On	On	On	Low

Current Draw Measurements and Sound Output Guide

Speed	DIP Switch Selection	Power Setting	Max DC Operating Current (mA RMS)	Audibility (dBA) Note 1	Audibility (dBA) Note 2
Fast (Exit)	10	High	185	84	75
Fast (Exit)	10	Med-High	131	81	72
Fast (Exit)	10	Med	78	78	69
Fast (Exit)	10	Med-Low	76	75	66
Fast (Exit)	10	Low	64	72	63
Med-Fast	9	High	170	83	74
Med-Fast	9	Med-High	124	80	71
Med-Fast	9	Med	75	77	68
Med-Fast	9	Med-Low	73	74	65
Med-Fast	9	Low	62	71	62
Med-Slow	8	High	135	82	73
Med-Slow	8	Med-High	104	79	70
Med-Slow	8	Med	67	76	67
Med-Slow	8	Med-Low	65	73	64
Med-Slow	8	Low	57	70	61
Slow	7	High	120	82	72
Slow	7	Med-High	92	79	69
Slow	7	Med	62	76	66
Slow	7	Med-Low	61	73	63
Slow	7	Low	54	70	60

Note 1: Sound output measured in anechoic room at 10 feet.
Note 2: Sound output measured in a reverberant room at 10 feet.

Language/Audible Tone Selection Guide

Rotary Switch Selection	Tone/Language		
0	Audible tone/sweep	8	Mandarin
1	English	9	English/Cantonese
2	Spanish	10	English/Mandarin
3	French	11	Cantonese/Mandarin
4	English/Spanish	12	English/Korean
5	English/French	13	English/Portuguese
6	Korean	14	English/Russian
7	Cantonese	15	English/Polish

Agency Listings and Approvals

Consult product manual for lists of compatible UL-Listed devices. In some cases, certain modules may not be listed by certain approval agencies, or listing may be in process. Consult factory for latest listing status.

- UL Listed: S4011
- FM Approved
- CSFM: 7135-1653:175
- MEA Approved: 492-04-E Vol. 2

Ordering Information

- PF24V** ExitPoint Directional Sounder with Voice Messaging
- BBS-SP201W** Surface mount backbox skirt for PF24V

ExitPoint™ is a trademark of Honeywell International Inc.
©2008 by Honeywell International Inc. All rights reserved. Unauthorized use of this document is strictly prohibited.



This document is not intended to be used for installation purposes.
We try to keep our product information up-to-date and accurate.
We cannot cover all specific applications or anticipate all requirements.
All specifications are subject to change without notice.



Made in the U.S. A.

For more information, contact Notifier. Phone: (203) 484-7161, FAX: (203) 484-7118.
www.notifier.com

315-080

80-Character Serial LCD Annunciator



General

The 315-080 annunciator is a compact, backlit, 80-character LCD fire annunciator that mimics the Fire Alarm Control Panel (FACP) display. It provides system status indicators for AC Power, Alarm, Trouble, Supervisory, and Alarm Silenced conditions. The 315-080 and the FACP communicate over a two-wire serial interface employing the Repeater-Bus communication format. Connected devices are powered, via two additional wires, by either the host FACP or a remote UL-listed, filtered power supply.

The 315-080 displays English-language text of system point information including device type, zone, independent point alarm, trouble or supervisory status, as well as any custom alpha labels programmed into the control panel. It includes control switches for remote control of critical system functions. (A keyswitch prevents unauthorized operation of the control switches.)

Up to eight 315-080 repeaters may be connected to the Repeater-Bus of each FACP. No programming is required, which saves time during system commissioning.



Controls and Indicators

- AC Power
- Alarm
- Supervisory
- Alarm Silenced
- Trouble

KEY FEATURES

- Listed to UL Standard 864, 9th Edition
- Backlit 80-character LCD display (20 characters x 4 lines)
- Mimics all display information from the host panel
- Control switches for System Acknowledge, Signal Silence, and Reset
- Control switches can be independently enabled or disabled at the FACP
- Keyswitch enables/disables control switches and mechanically locks annunciator enclosure
- Keyswitch can be enabled or disabled at the FACP
- Enclosure supervised for tamper
- System status LEDs for AC Power, Alarm, Trouble, Supervisory, and Alarm Silence
- Local sounder can be enabled or disabled at the FACP
- 315-080 connects to the Repeater-Bus terminal on the FACP and requires minimal panel programming
- Displays device type identifiers, individual point alarm, trouble, supervisory, zone, and custom alpha labels
- Time and date display field
- Surface mount directly to wall or to single, double, or 4" square electrical box
- Semi-flush mount to single, double, or 4" square electrical box. Use ANN-SB80KIT for angled view mounting
- Can be remotely located up to 6,000 feet (1,800 m) from the panel
- Backlight turns off during AC loss to conserve battery power but will turn back on if an alarm condition occurs
- May be powered by 24 VDC from the host FACP or by remote power supply (requires 24 VDC)
- Up to eight 315-080 repeaters can be connected on the RS485 Repeater-Bus

315-080 Technical Specifications

Operating voltage range	18 VDC to 28 VDC
Current consumption	@ 24 VDC nominal (filtered and non resettable): 40 mA maximum
Ambient temperature	32°F to 120°F (0°C to 49°C)
Relative humidity	93% ± 2% RH (non-condensing) at 32°C ± 2°C (90°F ± 3°F)
Dimension	5.375" (13.65 cm.) high x 6.875" (17.46 cm.) wide x 1.375" (3.49 cm.) deep
For use	Indoors in a dry location
Connections	All connections are power-limited and supervised

The Repeater-Bus:

• Powering the devices on the Repeater-Bus from auxiliary power supply

The Repeater-Bus can be powered by an auxiliary power supply when the maximum number of Repeater-Bus devices exceeds the Repeater-Bus power requirements. See the FACP manual for more information.

• Repeater-Bus Device Addressing

Each Repeater-Bus device requires a unique address (ID Number) in order to communicate with the FACP. A maximum of 8 devices can be connected to the FACP Repeater-Bus communication circuit. See the FACP manual for more information.

• Wire Requirements: Communications Circuit

The 315-080 connects to the FACP Repeater-Bus communications circuit. To determine the type of wire and the maximum wiring distance that can be used with FACP Repeater-Bus accessory modules, it is necessary to calculate the total worst case current draw for all modules on a single 4-conductor bus. The total worst case current draw is calculated by adding the individual worst case currents for each module.

NOTE: For total worst case current draw on a single Repeater-Bus refer to appropriate FACP manual.

• Wire Requirements: Power Circuit

- 14 to 18 AWG (0.75 - 2.08 mm²) wire for 24 VDC power circuit is acceptable. Power wire distance limitation is set by 1.2 volt maximum line drop from source to end of circuit.
- All connections are power-limited and supervised.
- A maximum of eight 315-080 repeater modules may be connected to this circuit.

Agency Listings and Approvals

The listings and approvals below apply to the 315-040. In some cases, certain modules may not be listed by certain approval agencies, or listing may be in process. Consult factory for latest listing status.

- **UL Listed:** S36108

Ordering Options

- **315-080:** Red 80 character LCD Annunciator

For more information

www.morley-ias.co.uk

Honeywell Building Technologies ASEAN

Level 25, UOA Corp Tower B, Avenue 10
The Vertical, Bangsar South City
59200, Kuala Lumpur, Malaysia
Email: Buildings.ASEAN@Honeywell.com

Honeywell Building Technologies India

Unitech Trade Centre, 5th Floor
Sector – 43, Block C, Sushant Lok Phase – 1
Gurgaon – 122002, Haryana, India
Email: HoneywellSecurity&Fire@Honeywell.com
Toll Free: 1-800-103-0339
www.honeywell.com

Honeywell Building Technologies META

Emaar Business Park, Building 2, 2nd Floor
Sheikh Zayed Road
P.O.Box 232362, Dubai, U.A.E.
Phone: +971 4 4505 847

HM-DMMI-UL, HM-MM3E-UL, HM-DCZRM-UL



General

Three different monitor modules are available for fire alarm control panels – suiting a variety of applications. Monitor modules supervise a circuit of drycontact input devices, such as conventional heat detectors and pull stations, or to monitor and power two-wire smoke detector circuits.

HM-DMMI-UL is a standard-sized module (typically mounts to a 4”/10.16 cm square box) that supervises Class B circuit of dry contact input devices.

HM-MM3E-UL is a miniature monitor module – 1.3” (3.302 cm) H x 2.75” (6.985 cm) W x 0.65” (1.651 cm) D – that supervises Class B circuit of dry-contact input devices. Thanks to its compact design, the HM-MM3E-UL can be mounted in a single-gang box behind the device it monitors.

HM-DCZRM-UL is a standard-sized module used to monitor and supervise compatible two-wire, 24-Volt, smoke on a Class B circuit.

The HM-DMMI-UL Monitor Module is intended for use in intelligent, two-wire systems, where the individual address of each module is selected using the built-in rotary switches. It provides either a two-wire or four-wire fault-tolerant Initiating Device Circuit (IDC) for normally open, contact fire alarm and supervisory devices. The module has a panel-controlled LED indicator.

HM-DMMI-UL Applications

Monitor a zone of four-wire smoke detectors, manual fire alarm pull stations, waterflow devices, or other normally open, drycontact alarm activation devices. Use it to monitor normally-open supervisory devices with special supervisory indication at the control panel. The monitored circuit may be wired as an NFPA (Class B) Initiating Device Circuit. A 47K Ohm end of line resistor (provided) terminates the Class B circuit.

HM-DMMI-UL Operation

Each HM-DMMI-UL uses one of the available module addresses on an SLC loop. It responds to regular polls from the control panel and reports its type and the status (open/normal/short) of its Initiating Device Circuit (IDC). A flashing LED indicates that the module communicates with the control panel. The LED steadily illuminates when an alarm starts (subject to current loop limitations).

HM-DMMI-UL Monitor Module



HM-DMMI-UL

- Built-in type identification automatically identifies this device as a monitor module to the control panel
- Powered directly by two-wire SLC loop. No additional power required
- High noise (EMF/RFI) immunity
- SEMS screws with clamping plates for easy wiring
- Direct-dial entry of address: 61-99 for models SMX and STX
- LED flashes during normal operation and steadily illuminates to indicate alarm

HM-DMMI-UL Specifications

Nominal operating voltage	15 to 32 VDC
Maximum current draw	5.0 mA (LED on)
Average operating current	375 μ A (LED flashing), 1 communication every 5 seconds, 47k EOL
Maximum IDC wiring resistance	1500 Ohms
Maximum IDC Voltage	11 V
EOL resistance	47K Ohms
Temperature range	32°F to 120°F (0°C to 49°C)
Humidity range	10% to 93% non-condensing
Dimensions	4.5" (11.43 cm) high x 4" (10.16 cm) wide x 1.25" (3.175 cm) deep. Mounts to a 4" (10.16 cm) square x 2.125" (5.398 cm) deep box

HM-MM3E-UL Min-Monitor Module



HM-MM3E-UL

- Powered directly by two-wire SLC loop
No additional power required
- High noise (EMF/RFI) immunity
- Tinned, stripped leads for easy wiring
- Direct-dial entry of address:
61-99 for models SMX and STX

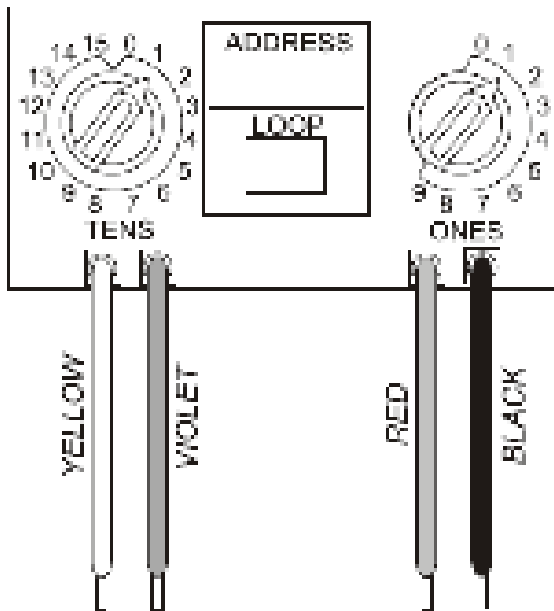

The HM-MM3E-UL Min-Monitor Module can be installed in a single-gang junction directly behind the monitored unit. Its small size and light weight allow it to be installed without rigid mounting. The HM-MM3E-UL is intended for use in intelligent, two-wire systems where the individual address of each module is selected using rotary switches. It provides a two-wire initiating device circuit for normally open, contact fire alarm devices.

HM-MM3E-UL Applications

Use to monitor a single device or a zone of four-wire smoke detectors, manual fire alarm pull stations, waterflow devices, or other normally open, dry contact devices. Monitor normally-open supervisory devices with special supervisory indication at the control panel. Monitored circuit/device is wired as an NFPA Class B Initiating Device Circuit. A 47K Ohm end of line resistor (provided) terminates the circuit.

HM-MM3E-UL Operation

Each HM-MM3E-UL uses one of the available module addresses on an SLC loop. It responds to regular polls from the control panel and reports its type and the status (open/normal/short) of its Initiating Device Circuit (IDC).

HM-MM3E-UL Specifications

Nominal operating voltage	15 to 32 VDC
Average operating current	350 μ A, 1 communication every 5 seconds, 47k EOL; 600 μ A Max. (Communicating, IDC Shorted)
Maximum IDC wiring resistance	1500 Ohms
Maximum IDC Voltage	11 V
Maximum IDC Current	450 μ A
EOL resistance	47K Ohms
Temperature range	32°F to 120°F (0°C to 49°C)
Humidity range	10% to 93% non-condensing
Dimensions	1.3" (3.302 cm) high x 2.75" (6.985 cm) wide x 0.65" (1.651 cm) deep
Wire length	6" (15.24 cm) minimum

HM-DCZRM-UL Interface Module



HM-DCZRM-UL

- Supports compatible two-wire smoke detectors
- Supervises IDC wiring and connection of external power source
- High noise (EMF/RFI) immunity
- SEMS screws with clamping plates for ease of wiring
- Direct-dial entry of address:
61 -99 for models SMX and STX
- LED flashes during normal operation
- LED steadily illuminates to indicate an alarm on command from the control panel

The HM-DCZRM-UL Interface Module is intended for use in intelligent, addressable systems, where the individual address of each module is selected using built-in rotary switches. This module allows intelligent panels to interface and monitor two-wire conventional smoke detectors. It transmits the status (normal, open, or alarm) of one full zone of conventional detectors back to the control panel. All two-wire detectors being monitored must be UL compatible with the module.

HM-DCZRM-UL Applications

Use the HM-DCZRM-UL to monitor a zone of two-wire smoke detectors. The monitored circuit may be wired as an NFPA Class B Initiating Device Circuit. A 3.9 K Ohm end of the line resistor (provided) terminates the end of the Class B circuit (maximum IDC loop resistance is 25 Ohms).

HM-DCZRM-UL Operation

Each HM-DCZRM-UL uses one of the available module addresses on an SLC loop. It responds to regular polls from the control panel and reports its type and the status (open/normal/short) of its Initiating Device Circuit (IDC). A flashing LED indicates that the module is in communication with the control panel. The LED steadily illuminates when an alarm is on (subject to current loop limitations).

HM-DCZRM-UL Specifications

Nominal operating voltage	15 to 32 VDC
Maximum current draw	5.1 mA (LED on)
Maximum IDC wiring resistance	25 Ohms
Average operating current	270 μ A, 1 communication and 1 LED flash every 5 seconds, 3.9k eol
EOL resistance	3.9K Ohms
External supply voltage (between Terminals T10 and T11)	<ul style="list-style-type: none">DC voltage: 24 V power limitedRipple voltage: 0.1 Vrms maximumCurrent: 90 mA per module maximum
Temperature range	32°F to 120°F (0°C to 49°C)
Humidity range	10% to 93% non-condensing
Dimensions	4.5" (11.43 cm) high x 4" (10.16 cm) wide x 1.25" (3.175 cm) deep. Mounts to a 4" (10.16 cm) square x 2.125" (5.398 cm) deep box

Installation

HM-DMMI-UL, and HM-DCZRM-UL modules mount directly to a standard 4" (10.16 cm) square, 2.125" (5.398 cm) deep, electrical box. They may also be mounted to the SMB500 surface mount box. Mounting hardware and installation instructions are provided with each module. All wiring must conform to applicable local codes, ordinances, and regulations. These modules are intended for power-limited wiring only.

The HM-MM3E-UL module is intended to be wired and mounted without rigid connections, inside a standard electrical box. All wiring must conform to applicable local codes, ordinances, and regulations.

Agency Listings and Approvals

Listing and approval below apply to the modules specified in this. In some cases, certain modules may not be listed by certain approval agencies, or listing may be in process. Consult factory for latest listing status.

- **UL:** S35595

Product Line Information

HM-DMMI-UL	Addressable Monitor Module
HM-MM3E-UL	Addressable Min-Monitor Module
HM-DCZRM-UL	Addressable Interface Module

NOTE: See installation instructions CN-MN-0196, CN-MN-0197 and CN-MN-0198 and refer to the SLC Wiring Manual.

Honeywell Building Technologies ASEAN

Level 25, UOA Corp Tower B, Avenue 10
The Vertical, Bangsar South City
59200, Kuala Lumpur, Malaysia
Email: Buildings.ASEAN@Honeywell.com

Honeywell Building Technologies India

Unitech Trade Centre, 5th Floor
Sector – 43, Block C, Sushant Lok Phase – 1
Gurgaon – 122002, Haryana, India
Email: HoneywellSecurity&Fire@Honeywell.com
Toll Free: 1-800-103-0339
www.honeywell.com

Honeywell Building Technologies META

Emaar Business Park, Building 2, 2nd Floor
Sheikh Zayed Road
P.O.Box 232362, Dubai, U.A.E.
Phone: +971 4 4505 847

HM-DMMI-UL, HM-MM3E-UL,
HM-DCZRM-UL | Rev 01 | 08/19

© 2019 Honeywell International Inc.



HM-D240CMO-UL



HM-D240CMO-UL

General

The HM-D240CMO-UL Addressable Relay Module provides the system with a dry contact output for activating a variety of auxiliary devices, such as fans, door holders, dampers, control equipment, etc. Addressability allows the dry contact to be activated through panel programming, on a select basis.

Applications

The HM-D240CMO-UL may be programmed to operate dry contacts for door holders, Air Handling Unit shutdown, etc., and to reset four-wire smoke detector power.

Construction

- The face plate is made of off-white, heat resistant plastic
- Controls include two rotary switches for direct-dial entry of address-setting
- The HM-D240CMO-UL is configured for a single Class B Notification Appliance Circuit
- The HM-D240CMO-UL provides two Form-C dry contacts that switch together

Operation

Each HM-D240CMO-UL uses one of the addresses on a SLC loop. It responds to regular polls from the control panel and reports its type and status. The LED blinks with each poll received. On command, it activates its internal relay.

NOTE: Open/short supervision is suspended with the HM-D240CMO-UL.

Rotary switches set a unique address for each module. The address may be set before or after mounting. The built-in TYPE CODE (not settable) will identify the module to the control panel, so as to differentiate between a control module and a relay module.

FEATURES & BENEFITS

- Built-in type identification automatically identifies these devices to the control panel
- Internal circuitry and relay powered directly by two-wire SLC loop
- Integral LED “blinks” green each time a communication is received from the control panel and turns on in steady red when activated
- High noise immunity (EMF/RFI)
- Wide viewing angle of LED
- SEMS screws with clamping plates for wiring ease
- Direct-dial entry of address: 61 -99 for models SMX and STX

HM-D240CMO-UL Technical Specifications

PARAMETER	SPECIFICATION
Normal operating voltage	15 to 32 VDC
Maximum SLC current draw	6.5 mA (LED on)
Average operating current	230 μ A direct poll (CLIP mode) with LED flashing
EOL resistance	Not Used.
Temperature range	32°F to 120°F (0°C to 49°C)
Humidity range	10% to 93% non-condensing
Dimensions	4.5" (11.43 cm) high x 4" (10.16 cm) wide x 1.25" (3.175 cm) deep. Mounts to a 4" (10.16 cm) square x 2.215" (5.398 cm) deep box

Relay Contact Ratings

- **Load Descripton:** Resistive
- **Application:** Non-Coded
- **Maximum Voltage:** 30 VDC
- **Current Rating:** 3.0 A

Agency Listings and Approvals

Listing and approval below apply to the modules specified in this. In some cases, certain modules may not be listed by certain approval agencies, or listing may be in process. Consult factory for latest listing status.

- **UL:** S35595

Product Line Information

HM-D240CMO-UL	Intelligent addressable relay module
SMB500	Optional surface-mount backbox
CB500	Optional control module barrier, required by UL for separating power-limited and non-power-limited wiring in the same junction box as HM-D240CMO-UL

NOTE: For installation instructions, see document CN-MN-0195 and refer to the SLC Wiring Manual.

Honeywell Building Technologies ASEAN

Level 25, UOA Corp Tower B, Avenue 10
The Vertical, Bangsar South City
59200, Kuala Lumpur, Malaysia
Email: Buildings.ASEAN@Honeywell.com

Honeywell Building Technologies META

Emaar Business Park, Building 2, 2nd Floor
Sheikh Zayed Road
P.O.Box 232362, Dubai, U.A.E.
Phone: +971 4 4505 847

Honeywell Building Technologies India

Unitech Trade Centre, 5th Floor
Sector – 43, Block C, Sushant Lok Phase – 1
Gurgaon – 122002, Haryana, India
Email: HoneywellSecurity&Fire@Honeywell.com
Toll Free: 1-800-103-0339
www.honeywell.com

HM-D240CMO-UL | Rev 01 | 08/19
© 2019 Honeywell International Inc.



HM-DCMO-UL

General

The HM-DCMO-UL Addressable Control Module provides a circuit for Notification appliances like horns, strobes, and more. Addressability allows the HM-DCMO-UL to be activated through panel programming, on a select (zone or area of coverage) basis.

Applications

The HM-DCMO-UL is used to switch 24 VDC audible/visual power.

Construction

- The face plate is made of off-white, heat resistant plastic
- Controls include two rotary switches for direct-dial entry of address-setting
- The HM-DCMO-UL is configured for a single Class B Notification Appliance Circuit

Operation

Each HM-DCMO-UL uses one of the module addresses on a SLC loop. It responds to regular polls from the control panel and reports its type and status, including the open/normal/ short status of its Notification Appliance Circuit (NAC). The LED blinks with each poll received. On command, it activates its internal relay. The HM-DCMO-UL supervises Class B notification or control circuits.

Upon code command from the panel, the HM-DCMO-UL will disconnect the supervision and connect the external power supply in the proper polarity across the load device. The disconnection of the supervision provides a positive indication to the panel that the control relay turned ON. The external power supply is always relay-isolated

from the communication loop, so that a trouble condition on the external power supply doesn't interfere with the rest of the system.

Rotary switches set a unique address for each module. The address may be set before or after mounting. The built-in TYPE CODE (not settable) of the control panel will identify the module, so as to differentiate between a module and a sensor address.



HM-DCMO-UL

FEATURES & BENEFITS

- Built-in type identification automatically matches devices to the control panel
- Internal circuitry powered directly by a two-wire SLC loop The HM-DCMO-UL module requires power (for horns, strobes, etc.)
- Integral green LED blinks each time a communication is received from the control panel and turns on steady red when activated
- High noise immunity (EMF/RFI)
- The HM-DCMO-UL may be used to switch 24-volt NAC power
- Wide viewing angle of LED
- SEMS screws with clamping plates for easy wiring
- Direct-dial entry of address: 61 -99 for models SMX and STX

HM-DCMO-UL Technical Specifications

PARAMETER	SPECIFICATION
Normal operating voltage	15 to 32 VDC
Maximum SLC current draw	6.5 mA (LED on)
Average operating current	350 µA direct poll (CLIP mode) with LED flashing
External supply voltage	maximum 80 Volts (RMS or DC)
Drain on external supply	2 mA maximum (using internal EOL relay)
EOL resistance	47K ohms
Temperature range	32°F to 120°F (0°C to 49°C)
Humidity range	10% to 93% non-condensing
Dimensions	<ul style="list-style-type: none">• 4.5" (11.43 cm) high x 4" (10.16 cm) wide x 1.25" (3.175 cm) deep• Mounts to a 4" (10.16 cm) square x 2.215" (5.398 cm) deep box

Agency Listings and Approvals

Listing and approval below apply to the modules specified in this. In some cases, certain modules may not be listed by certain approval agencies, or listing may be in process. Consult factory for latest listing status.

- ULC: S35595

Product Line Information

HM-DCMO-UL	Intelligent addressable control module
SMB500	Optional surface-mount backbox
CB500	Optional control module barrier, required by UL for separating power-limited and non-power-limited wiring in the same junction box as HM-DCMO-UL

NOTE: For installation instructions, see document CN-MN-0194 and refer to the SLC Wiring Manual.

Honeywell Building Technologies ASEAN

Level 25, UOA Corp Tower B, Avenue 10
The Vertical, Bangsar South City
59200, Kuala Lumpur, Malaysia
Email: Buildings.ASEAN@Honeywell.com

Honeywell Building Technologies META

Emaar Business Park, Building 2, 2nd Floor
Sheikh Zayed Road
P.O.Box 232362, Dubai, U.A.E.
Phone: +971 4 4505 847

Honeywell Building Technologies India

Unitech Trade Centre, 5th Floor
Sector – 43, Block C, Sushant Lok Phase – 1
Gurgaon – 122002, Haryana, India
Email: HoneywellSecurity&Fire@Honeywell.com
Toll Free: 1-800-103-0339
www.honeywell.com

HM-DCMO-UL | Rev 01 | 08/19
© 2019 Honeywell International Inc.

