

ZETA Ladder

CABLE LADDER

The ICMS cable ladder system consists of a wide range of aluminum and Steel cable ladders, Fittings and accessories.

Ladder Trays are available in two models:

- Tubular rungs mechanically swaged to side rails.
- C-Profile rungs arc welded to side rails in two options
 - Outside flange construction (shown in the catalogue)
 - Inside flange construction (Upon request)

It is the perfect solution for a wide variety of installations where corrosion-resistance, high loading capacity with long spans and quick and easy installation is needed.

The advantages of ZETA LADDER are appreciated particularly in demanding conditions or complex installations, for example in industrial plants, chemical and petrochemical plants, in tunnel and bridge constructions, water treatment works, outdoors and in close proximity to the sea.

Related Standards:

- NEMA VE-1
- BS EN 61537:2007
- QCS

Straight Ladder Ordering Way :

Example:

ZST 12C 3 _ 09 _ 18 _ 20 _ AL

Model	NEMA Class	Load Depth	Rung Spacing	Width	Length	Material/ Finish.
ZST	8A 12-A	3" (76 mm)	06" (152 mm)	06" (152 mm)	10' (3.0 mtr)	PG: Pre galvanized Steel
ZSC	12B	4" (102 mm)	09" (229 mm)	09" (229 mm)	12' (3.7 mtr)	HG: Hot Dip Galvanized
	12C	5" (127 mm)	12" (305 mm)	12" (305 mm)	20' (6.0 mtr)	AL: Aluminum
	16A	6" (152 mm)	18" (457 mm)	18" (457 mm)	24' (7.3 mtr)	S4: Stainless Steel 304
	16B			24" (610 mm)		S6: Stainless Steel 316
	16C			30" (762 mm)		CA: Corten-A Steel
	20A			36" (914 mm)		HP: Hot Dip Galvanized & Epoxy Powder Coated
	20B					
	20C					

*HDG To BS EN 1461
*For other finishing consult factory

Example Explanation:

- Cable Ladder straight.
- Tubular swaged rugs type.
- NEMA class 12.C.
- Rung spacing 229mm (9").
- Inside width 457mm (18").
- Load depth 76mm (3").
- Length 6.0m (20').
- Material: Aluminum

**Applicable for the NEMA Cable ladder only

Model ZST:

Tubular Rungs Ladder

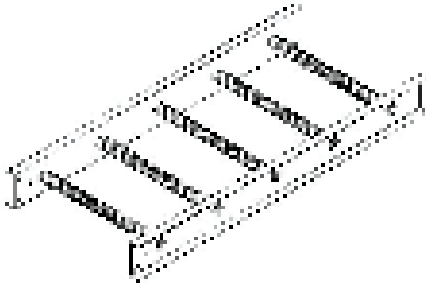

Model ZSC:

C-Profile Rungs Ladder

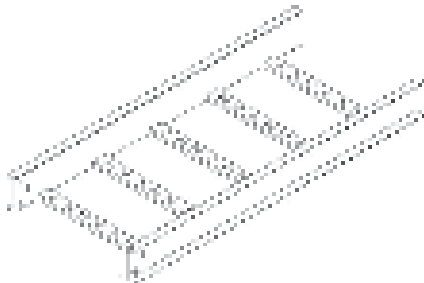

Cross Section

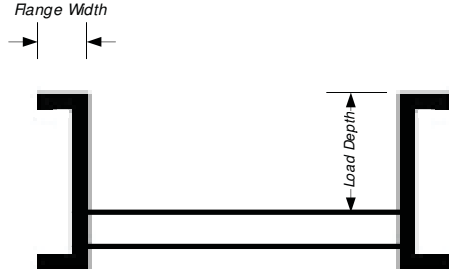
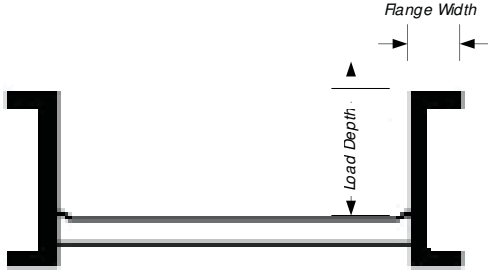

Rungs

Construction:
Rungs Attached to side rails
by mechanical Swaging

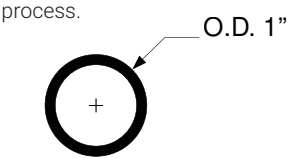

Rungs

Construction:
Rungs Attached to side rails by Arc Welding.

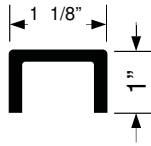

Hole Configuration

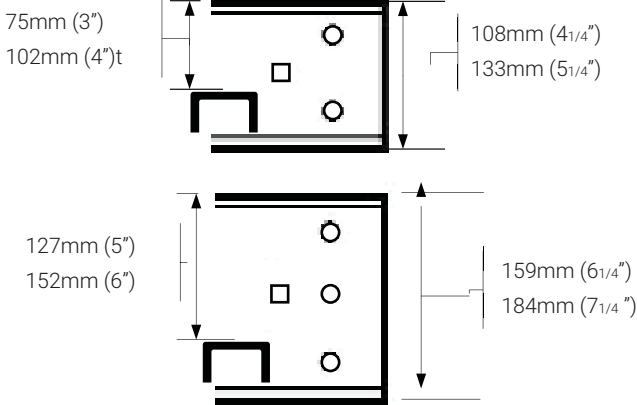
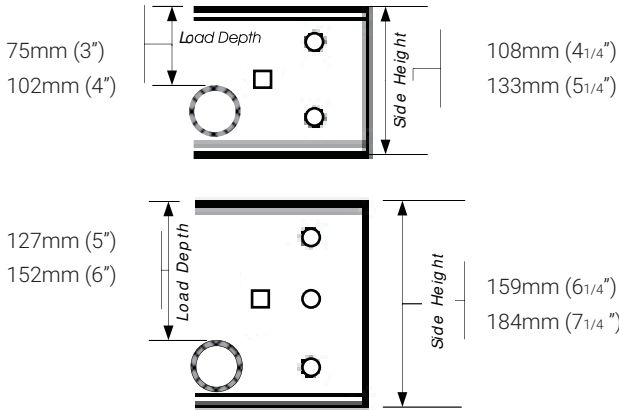

Aluminium Cable Ladder

Aluminum Ladder Model No.		Span: 6 ft.		Span: 8 ft.		Span: 10 ft.		Span: 12 ft.		Span: 16 ft.		Span: 20 ft.		Span: 24 ft.	
Tubular Rung ZST	C-Profile Rung ZSC	Load	Def.	Load	Def.	Load	Def.	Load	Def.	Load	Def.	Load	Def.	Load	Def.
		(lb/ft)	(in)	(lb/ft)	(in)	(lb/ft)	(in)	(lb/ft)	(in)	(lb/ft)	(in)	(lb/ft)	(in)	(lb/ft)	(in)
ZST12A 3	ZSC 12A 3	222	0.35	125	0.63	80	0.99	55	1.42						
ZST12B 3	ZSC 12B 3	354	0.45	191	0.76	117	1.14	78	1.57						
ZST12C 3	ZSC 12C 3	448	0.39	251	0.69	161	1.08	112	1.55						
ZST16A 3	ZSC 16A 3			251	0.69	161	1.08	112	1.55	51	2.26				
ZST16B 3	ZSC 16B 3			342	0.72	219	1.12	152	1.61	82	2.74				
ZST16C 3	ZSC 16C 3			444	0.71	284	0.70	188	1.53	106	2.73				
ZST20A 3	ZSC 20A 3							152	1.61	82	2.74	52	4.27		
ZST20B 3	ZSC 20B 3							188	1.53	106	2.73	73	4.44		
ZST20C 3	ZSC 20C 3							298	1.79	161	3.07	103	4.79		
ZST12A 4	ZSC 12A 4	324	0.33	125	0.59	117	0.87	77	1.26						
ZST12B 4	ZSC 12B 4	324	0.33	125	0.59	117	0.87	77	1.26						
ZST12C 4	ZSC 12C 4	394	0.31	222	0.55	142	0.86	100	1.24						
ZST16A 4	ZSC 16A 4			349	0.51	223	0.80	155	1.15	79	1.85				
ZST16B 4	ZSC 16B 4			349	0.51	223	0.80	155	1.15	79	1.85				
ZST16C 4	ZSC 16C 4			525	0.55	336	0.86	233	1.24	119	2.01				
ZST20A 4	ZSC 20A 4							155	1.15	79	1.85	51	2.89		
ZST20B 4	ZSC 20B 4							233	1.24	119	2.01	76	3.14		
ZST20C 4	ZSC 20C 4							290	1.35	156	2.30	100	3.59		
ZST12A 5	ZSC 12A 5	359	0.22	191	0.37	115	0.55	75	0.74						
ZST12B 5	ZSC 12B 5	359	0.22	191	0.37	115	0.55	75	0.74						
ZST12C 5	ZSC 12C 5	480	0.24	257	0.40	156	0.60	102	0.81						
ZST16A 5	ZSC 16A 5			380	0.49	222	0.69	154	1.00	78	1.61				
ZST16B 5	ZSC 16B 5			380	0.49	222	0.69	154	1.00	78	1.61				
ZST16C 5	ZSC 16C 5			511	0.51	328	0.76	229	1.00	116	1.60				
ZST20A 5	ZSC 20A 5							154	1.00	78	1.61	50	2.51		
ZST20B 5	ZSC 20B 5							229	1.00	116	1.60	75	2.50		
ZST20C 5	ZSC 20C 5							281	1.09	158	1.94	101	3.02		
ZST20C+ 5	ZSC 20C+ 5							451	1.20	253	2.14	162	3.35	112	4.79
ZST12A 6	ZSC 12A 6	416	0.18	221	0.31	133	0.46	87	0.62						
ZST12B 6	ZSC 12B 6	416	0.18	221	0.31	133	0.46	87	0.62						
ZST12C 6	ZSC 12C 6	540	0.17	286	0.29	172	0.43	111	0.57						
ZST16A 6	ZSC 16A 6							316	0.86	161	1.38	103	2.16		
ZST16B 6	ZSC 16B 6							316	0.86	161	1.38	103	2.16		
ZST16C 6	ZSC 16C 6							316	0.86	161	1.38	103	2.16		
ZST20A 6	ZSC 20A 6							316	0.86	161	1.38	103	2.16		
ZST20B 6	ZSC 20B 6							316	0.86	161	1.38	103	2.16		
ZST20C 6	ZSC 20C 6							316	0.86	161	1.38	103	2.16		
ZST20C+ 6	ZSC 20C+ 6							451	1.20	253	2.14	162	3.35	112	4.79

- Data above based on simple beam tests as per NEMA VE-1
- Rungs Load capacity 200 lbs (0.89 kN) concentrated load applied at center of the rung with safety factor: 1.5
- Deflection is reduced to approx. 50% when cable ladders used in continuous spans.
- Load: Allowable Uniform in Lbs/ft. to convert to Kg/m. multiply by 1.48
- Data in table based on 1.5 safety factor, to change to 2 multiply load by 0.75

Steel & SS Cable Ladder															
Steel & SSLadder Model No.		Span: Load (lb/ft)	6 ft. Def. (in)	Span: Load (lb/ft)	8 ft. Def. (in)	Span: Load (lb/ft)	10 ft. Def. (in)	Span: Load (lb/ft)	12 ft. Def. (in)	Span: Load (lb/ft)	16 ft. Def. (in)	Span: Load (lb/ft)	20 ft. Def. (in)	Span: Load (lb/ft)	24 ft. Def. (in)
Tubular Rung ZST	C-Profile Rung ZSC														
ZST12A 3	ZSC 12A 3	360	0.26	198	0.46	124	0.70	84	0.98						
ZST12B 3	ZSC 12B 3	360	0.26	198	0.46	124	0.70	84	0.98						
ZST12C 3	ZSC 12C 3	453	0.27	249	0.47	156	0.71	106	1.00						
ZST16A 3	ZSC 16A 3			290	0.53	182	0.81	126	1.17	65	1.91				
ZST16B 3	ZSC 16B 3			381	0.56	244	0.88	169	1.27	88	2.08				
ZST16C 3	ZSC 16C 3			487	0.58	312	0.91	216	1.31	113	2.16				
ZST20A 3	ZSC 20A 3							169	1.27	88	2.08	52	2.98		
ZST20B 3	ZSC 20B 3							304	1.36	159	2.24	94	3.23		
ZST20C 3	ZSC 20C 3							344	0.88	178	1.50	107	2.20		
ZST12A 4	ZSC 12A 4	383	0.18	210	0.31	127	0.46	83	0.62						
ZST12B 4	ZSC 12B 4	383	0.18	210	0.31	127	0.46	83	0.62						
ZST12C 4	ZSC 12C 4	456	0.20	244	0.33	152	0.51	103	0.71						
ZST16A 4	ZSC 16A 4			382	0.42	245	0.66	170	0.94	86	1.54				
ZST16B 4	ZSC 16B 4			382	0.42	245	0.66	170	0.94	86	1.54				
ZST16C 4	ZSC 16C 4			444	0.42	273	0.63	186	0.89	100	1.51				
ZST20A 4	ZSC 20A 4							186	0.89	100	1.51	53	1.94		
ZST20B 4	ZSC 20B 4							280	1.02	145	1.67	85	2.40		
ZST20C 4	ZSC 20C 4							395	1.05	206	1.74	121	2.50		
ZST12A 5	ZSC 12A 5	357	0.11	194	0.18	119	0.28	79	0.38						
ZST12B 5	ZSC 12B 5	357	0.11	194	0.18	119	0.28	79	0.38						
ZST12C 5	ZSC 12C 5	460	0.11	250	0.19	154	0.29	103	0.40						
ZST16A 5	ZSC 16A 5			268	0.20	166	0.31	111	0.43	58	0.71				
ZST16B 5	ZSC 16B 5			574	0.35	367	0.55	245	0.76	123	1.22				
ZST16C 5	ZSC 16C 5			574	0.35	367	0.55	245	0.76	123	1.22				
ZST20A 5	ZSC 20A 5							245	0.76	123	1.22	66	1.59		
ZST20B 5	ZSC 20B 5							269	0.80	139	1.28	81	1.82		
ZST20C 5	ZSC 20C 5							296	0.79	152	1.28	105	1.91		
ZST20C+ 5	ZSC 20C+ 5							434	0.66	244	1.17	156	1.82	108	2.62
ZST12A 6	ZSC 12A 6	680	0.12	328	0.19	182	0.26	107	0.31						
ZST12B 6	ZSC 12B 6	680	0.12	328	0.19	182	0.26	107	0.31						
ZST12C 6	ZSC 12C 6	680	0.12	328	0.19	182	0.26	107	0.31						
ZST16A 6	ZSC 16A 6							178	0.38	93	0.62				
ZST16B 6	ZSC 16B 6							178	0.38	93	0.62				
ZST16C 6	ZSC 16C 6							202	0.51	101	0.80				
ZST20A 6	ZSC 20A 6							178	0.38	93	0.62	55	0.91		
ZST20B 6	ZSC 20B 6							291	0.59	148	0.95	85	1.33		
ZST20C 6	ZSC 20C 6							379	0.66	191	1.05	102	1.37		
ZST20C+ 6	ZSC 20C+ 6							434	0.66	244	1.17	156	1.82	108	2.62

- Design cross-sectional area as per NEC 392.7 shows the minimum area of both side rails required for cable tray to be used as Equipment Grounding Conductor (EGC) for specific short circuit current rating.

Aluminium Cable Ladder

Aluminum Ladder Model No.		NEMA VE-1 Classification	NEMA VE-1 (Load/Span)	Nominal Load Depth in (mm)	Overall Side Rail Height in (mm)	Flange Width in (mm)	Design Cross-Sec. Area (sq.in)
Tubular Rung ZST	C-Profile Rung ZSC						
ZST 12A 3	ZSC 12A 3	8A -12A	50 lb/ft@12> span			13/16»(21mm)	0.60
ZST 12B 3	ZSC 12B 3	12B	75 lb/ft@12> span			13/16»(21mm)	0.60
ZST 12C 3	ZSC 12C 3	12C	100 lb/ft@12> span			13/16»(21mm)	1.00
ZST 16A 3	ZSC 16A 3	16A	50 lb/ft@16> span	3»	4 1/4»	13/16»(21mm)	1.00
ZST 16B 3	ZSC 16B 3	16B	75 lb/ft@16> span	(76mm)	(108mm)	1 1/4»(32mm)	1.50
ZST 16C 3	ZSC 16C 3	16C	100 lb/ft@16> span			1 1/4»(32mm)	1.50
ZST 20A 3	ZSC 20A 3	20A	50 lb/ft@20> span			1 1/4»(32mm)	1.50
ZST 20B 3	ZSC 20B 3	20B	75 lb/ft@20> span			1 1/2»(38mm)	2.00
ZST 20C 3	ZSC 20C 3	20C	100 lb/ft@20> span			1 1/2»(38mm)	2.00
ZST 12A 4	ZSC 12A 4	8A -12A	50 lb/ft@12> span			13/16»(21mm)	0.60
ZST 12B 4	ZSC 12B 4	12B	75 lb/ft@12> span			13/16»(21mm)	0.60
ZST 12C 4	ZSC 12C 4	12C	100 lb/ft@12> span			13/16»(21mm)	1.00
ZST 16A 4	ZSC 16A 4	16A	50 lb/ft@16> span	4»	5 1/4»	1 1/4»(32mm)	1.50
ZST 16B 4	ZSC 16B 4	16B	75 lb/ft@16> span	(102mm)	(133mm)	1 1/4»(32mm)	1.50
ZST 16C 4	ZSC 16C 4	16C	100 lb/ft@16> span			1 1/4»(32mm)	2.00
ZST 20A 4	ZSC 20A 4	20A	50 lb/ft@20> span			1 1/4»(32mm)	1.50
ZST 20B 4	ZSC 20B 4	20B	75 lb/ft@20> span			1 1/4»(32mm)	2.00
ZST 20C 4	ZSC 20C 4	20C	100 lb/ft@20> span			1 1/2»(38mm)	2.00
ZST 12A 5	ZSC 12A 5	8A -12A	50 lb/ft@12> span			13/16»(21mm)	1.00
ZST 12B 5	ZSC 12B 5	12B	75 lb/ft@12> span			13/16»(21mm)	1.00
ZST 12C 5	ZSC 12C 5	12C	100 lb/ft@12> span			13/16»(21mm)	1.00
ZST 16A 5	ZSC 16A 5	16A	50 lb/ft@16> span	5»	6 1/4»	1 1/4»(32mm)	1.00
ZST 16B 5	ZSC 16B 5	16B	75 lb/ft@16> span	(127mm)	(159mm)	1 1/4»(32mm)	1.00
ZST 16C 5	ZSC 16C 5	16C	100 lb/ft@16> span			1 1/4»(32mm)	2.00
ZST 20A 5	ZSC 20A 5	20A	50 lb/ft@20> span			1 1/4»(32mm)	1.00
ZST 20B 5	ZSC 20B 5	20B	75 lb/ft@20> span			1 1/4»(32mm)	1.50
ZST 20C 5	ZSC 20C 5	20C	100 lb/ft@20> span			1 1/2»(38mm)	2.00
ZST 20C+ 5	ZSC 20C+ 5	20C+	100 lb/ft@24> span			2» (50.8mm)	2.00
ZST 12A 6	ZSC 12A 6	8A -12A	50 lb/ft@12> span			13/16»(21mm)	1.00
ZST 12B 6	ZSC 12B 6	12B	75 lb/ft@12> span			13/16»(21mm)	1.00
ZST 12C 6	ZSC 12C 6	12C	100 lb/ft@12> span			13/16»(21mm)	1.00
ZST 16A 6	ZSC 16A 6	16A	50 lb/ft@16> span	6»	7 1/4»	1 1/4»(32mm)	2.00
ZST 16B 6	ZSC 16B 6	16B	75 lb/ft@16> span	(152mm)	(184mm)	1 1/4»(32mm)	2.00
ZST 16C 6	ZSC 16C 6	16C	100 lb/ft@16> span			1 1/4»(32mm)	2.00
ZST 20A 6	ZSC 20A 6	20A	50 lb/ft@20> span			1 1/4»(32mm)	2.00
ZST 20B 6	ZSC 20B 6	20B	75 lb/ft@20> span			1 1/2»(38mm)	1.50
ZST 20C 6	ZSC 20C 6	20C	100 lb/ft@20> span			1 1/2»(38mm)	2.00
ZST 20C+ 5	ZSC 20C+ 6	20C+	100 lb/ft@24> span			2» (50.8mm)	2.00

- Design cross-sectional area as per NEC 392.7 shows the minimum area of both side rails required for cable tray to be used as Equipment Grounding Conductor for specific short circuit current rating.

Steel & SS Cable Ladder							
Aluminum Ladder Model No.		NEMA VE-1 Classification	NEMA VE-1 (Load/Span)	Nominal Load Depth in (mm)	Overall Side Rail Height in (mm)	Flange Width in (mm)	Design Cross-Sec. Area (sq.in)
Tubular Rung ZST	C-Profile Rung ZSC						
ZST 12A 3	ZSC 12A 3	8A -12A	50 lb/ft@12> span			13/16»(21mm)	0.40
ZST 12B 3	ZSC 12B 3	12B	75 lb/ft@12> span			13/16»(21mm)	0.40
ZST 12C 3	ZSC 12C 3	12C	100 lb/ft@12> span			13/16»(21mm)	0.70
ZST 16A 3	ZSC 16A 3	16A	50 lb/ft@16> span	3»	4 1/4»	13/16»(21mm)	0.40
ZST 16B 3	ZSC 16B 3	16B	75 lb/ft@16> span	(76mm)	(108mm)	1 1/4»(32mm)	0.70
ZST 16C 3	ZSC 16C 3	16C	100 lb/ft@16> span			1 1/4»(32mm)	1.00
ZST 20A 3	ZSC 20A 3	20A	50 lb/ft@20> span			1 1/4»(32mm)	0.70
ZST 20B 3	ZSC 20B 3	20B	75 lb/ft@20> span			1 1/2»(38mm)	1.00
ZST 20C 3	ZSC 20C 3	20C	100 lb/ft@20> span			1 1/2»(38mm)	1.00
ZST 12A 4	ZSC 12A 4	8A -12A	50 lb/ft@12> span			13/16»(21mm)	0.40
ZST 12B 4	ZSC 12B 4	12B	75 lb/ft@12> span			13/16»(21mm)	0.40
ZST 12C 4	ZSC 12C 4	12C	100 lb/ft@12> span			13/16»(21mm)	0.40
ZST 16A 4	ZSC 16A 4	16A	50 lb/ft@16> span	4»	5 1/4»	1 1/4»(32mm)	0.70
ZST 16B 4	ZSC 16B 4	16B	75 lb/ft@16> span	(102mm)	(133mm)	1 1/4»(32mm)	0.70
ZST 16C 4	ZSC 16C 4	16C	100 lb/ft@16> span			1 1/4»(32mm)	0.70
ZST 20A 4	ZSC 20A 4	20A	50 lb/ft@20> span			1 1/4»(32mm)	0.70
ZST 20B 4	ZSC 20B 4	20B	75 lb/ft@20> span			1 1/4»(32mm)	1.00
ZST 20C 4	ZSC 20C 4	20C	100 lb/ft@20> span			1 1/2»(38mm)	1.50
ZST 12A 5	ZSC 12A 5	8A -12A	50 lb/ft@12> span			13/16»(21mm)	0.70
ZST 12B 5	ZSC 12B 5	12B	75 lb/ft@12> span			13/16»(21mm)	0.70
ZST 12C 5	ZSC 12C 5	12C	100 lb/ft@12> span			13/16»(21mm)	0.70
ZST 16A 5	ZSC 16A 5	16A	50 lb/ft@16> span	5»	6 1/4»	1 1/4»(32mm)	0.70
ZST 16B 5	ZSC 16B 5	16B	75 lb/ft@16> span	(127mm)	(159mm)	1 1/4»(32mm)	1.00
ZST 16C 5	ZSC 16C 5	16C	100 lb/ft@16> span			1 1/4»(32mm)	1.00
ZST 20A 5	ZSC 20A 5	20A	50 lb/ft@20> span			1 1/4»(32mm)	1.00
ZST 20B 5	ZSC 20B 5	20B	75 lb/ft@20> span			1 1/4»(32mm)	1.00
ZST 20C 5	ZSC 20C 5	20C	100 lb/ft@20> span			1 1/2»(38mm)	1.00
ZST 20C+ 5	ZSC 20C+ 5	20C+	100 lb/ft@24> span			2» (50.8mm)	1.50
ZST 12A 6	ZSC 12A 6	8A -12A	50 lb/ft@12> span			13/16»(21mm)	0.70
ZST 12B 6	ZSC 12B 6	12B	75 lb/ft@12> span			13/16»(21mm)	0.70
ZST 12C 6	ZSC 12C 6	12C	100 lb/ft@12> span			13/16»(21mm)	0.70
ZST 16A 6	ZSC 16A 6	16A	50 lb/ft@16> span	6»	7 1/4»	1 1/4»(32mm)	1.00
ZST 16B 6	ZSC 16B 6	16B	75 lb/ft@16> span	(152mm)	(184mm)	1 1/4»(32mm)	1.00
ZST 16C 6	ZSC 16C 6	16C	100 lb/ft@16> span			1 1/4»(32mm)	0.70
ZST 20A 6	ZSC 20A 6	20A	50 lb/ft@20> span			1 1/4»(32mm)	1.00
ZST 20B 6	ZSC 20B 6	20B	75 lb/ft@20> span			1 1/2»(38mm)	1.00
ZST 20C 6	ZSC 20C 6	20C	100 lb/ft@20> span			1 1/2»(38mm)	1.00
ZST 20C+ 6	ZSC 20C+ 6	20C+	100 lb/ft@24> span			2» (50.8mm)	1.50

- Design cross-sectional area as per NEC 392.7 shows the minimum area of both side rails required for cable tray to be used as Equipment Grounding Conductor for specific short circuit current rating.

For a completely integrated system, the ZETA LADDER fittings provide: electrical continuity, continuous support, positive radius control, protection against physical damage, ease of installation. engineered performance and factory-controlled quality of components. Fittings have a max. rung spacing of 9 in. o.c. measured at the center line of the fitting.

Fitting flanges are designed to maintain surface continuity inside the tray system and avoid exposed sharp edges.

Fittings are designed with 3" (76mm) tangent for splicing integrity.

Ladder Fittings Ordering Way :

Example:

Fitting Type	Radius	Width	Model	Load Depth	Material/Finish.
HB90: 90Deg .Horizontal Elbow	305 mm (12")	152 mm (06")	T: Tubular Rungs Swaged	76 mm (3")	PG: Pre galvanized Steel
HB60: 60Deg .Horizontal Elbow	610 mm (24")	229 mm (09")	C: C-Profile Rungs Welded	102 mm (4")	HG: Hot Dip Galvanized
HB45: 45Deg .Horizontal Elbow	914 mm (36")	305 mm (12")		127 mm (5")	AL: Aluminum
HB30: 30Deg .Horizontal Elbow		457 mm (18")		152 mm (6")	S4: Stainless Steel 304
HT: Horizontal Tee		610 mm (24")			S6: Stainless Steel 316
HC: Horizontal Cross		762 mm (30")			HP: Hot Dip Galvanized & Epoxy Powder Coated
VI90: 90Deg .Vertical Inside Elbow		914 mm (36")			
VI60: 60Deg .Vertical Inside Elbow					
VI45: 45Deg .Vertical Inside Elbow					
VI30: 30Deg .Vertical Inside Elbow					
VO90: 90Deg .Vertical Outside Elbow					
VO60: 60Deg .Vertical Outside Elbow					
VO45: 45Deg .Vertical Outside Elbow					
VO30: 30Deg .Vertical Outside Elbow					
VT: Vertical Tee					
VS: Vertical Support fitting					
HYL: Horizontal- Y Left					
HYR: Horizontal- Y Right					
RS: Reducer straight					
RR: Reducer Right Hand					
RL: Reducer Left Hand					

*For other finishing consult factory

Above Example:

Fitting, Horizontal Tee, Tubular Rungs Type 3", Load Depth 1/4 4", Side rail height 24", Radius18", Wide, Material Aluminum.

HB45

45 Deg Horizontal Elbow

Fitting Radius in (mm)	Width in (mm)	Part No Model no - Prefix	B	
			in	(mm)
12" (305mm)	06" (152mm)	HB45 1206 - prefix	18"	(457)
	09" (229mm)	HB45 1209 - prefix	21"	(533)
	12" (305mm)	HB45 1212 - prefix	24"	(610)
	18" (457mm)	HB45 1218 - prefix	30"	(762)
	24" (610mm)	HB45 1224 - prefix	36"	(914)
	30" (762mm)	HB45 1230 - prefix	42"	(1067)
	36" (914mm)	HB45 1236 - prefix	48"	(1219)
24" (610mm)	06" (152mm)	HB45 2406 - prefix	30"	(762)
	09" (229mm)	HB45 2409 - prefix	33"	(838)
	12" (305mm)	HB45 2412 - prefix	36"	(914)
	18" (457mm)	HB45 2418 - prefix	42"	(1067)
	24" (610mm)	HB45 2424 - prefix	48"	(1219)
	30" (762mm)	HB45 2430 - prefix	54"	(1372)
	36" (914mm)	HB45 2436 - prefix	60"	(1524)
36" (914mm)	06" (152mm)	HB45 3606 - prefix	42"	(1067)
	09" (229mm)	HB45 3609 - prefix	45"	(1143)
	12" (305mm)	HB45 3612 - prefix	48"	(1219)
	18" (457mm)	HB45 3618 - prefix	54"	(1372)
	24" (610mm)	HB45 3624 - prefix	60"	(1524)
	30" (762mm)	HB45 3630 - prefix	66"	(1676)
	36" (914mm)	HB45 3636 - prefix	72"	(1829)

Application:
For Making 45 Deg.
turns on the same plan.

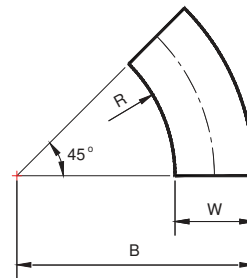
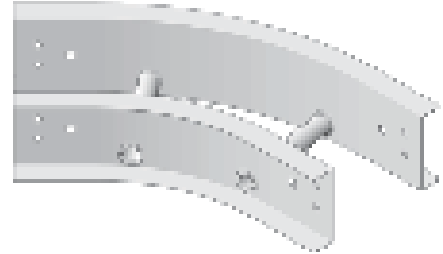

HB30

30 Deg Horizontal Elbow

Fitting Radius in (mm)	Width in (mm)	Part No Model no - Prefix	B	
			in	(mm)
12" (305mm)	06" (152mm)	HB30 1206 - prefix	18"	(457)
	09" (229mm)	HB30 1209 - prefix	21"	(533)
	12" (305mm)	HB30 1212 - prefix	24"	(610)
	18" (457mm)	HB30 1218 - prefix	30"	(762)
	24" (610mm)	HB30 1224 - prefix	36"	(914)
	30" (762mm)	HB30 1230 - prefix	42"	(1067)
	36" (914mm)	HB30 1236 - prefix	48"	(1219)
24" (610mm)	06" (152mm)	HB30 2406 - prefix	30"	(762)
	09" (229mm)	HB30 2409 - prefix	33"	(838)
	12" (305mm)	HB30 2412 - prefix	36"	(914)
	18" (457mm)	HB30 2418 - prefix	42"	(1067)
	24" (610mm)	HB30 2424 - prefix	48"	(1219)
	30" (762mm)	HB30 2430 - prefix	54"	(1372)
	36" (914mm)	HB30 2436 - prefix	60"	(1524)
36" (914mm)	06" (152mm)	HB30 3606 - prefix	42"	(1067)
	09" (229mm)	HB30 3609 - prefix	45"	(1143)
	12" (305mm)	HB30 3612 - prefix	48"	(1219)
	18" (457mm)	HB30 3618 - prefix	54"	(1372)
	24" (610mm)	HB30 3624 - prefix	60"	(1524)
	30" (762mm)	HB30 3630 - prefix	66"	(1676)
	36" (914mm)	HB30 3636 - prefix	72"	(1829)

Application:
For Making 30 Deg.
turns on the same plan.

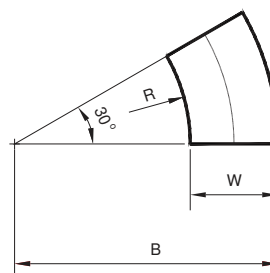
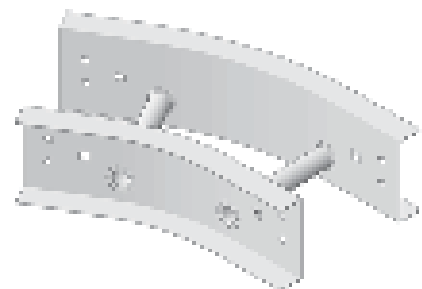

HB90

90 Deg Horizontal Elbow

Fitting Radius in (mm)	Width in (mm)	Part No Model no - Prefix	B	
			in	(mm)
12" (305mm)	06" (152mm)	HB901206 - prefix	18"	(457)
	09" (229mm)	HB901209 - prefix	21"	(533)
	12" (305mm)	HB901212 - prefix	24"	(610)
	18" (457mm)	HB901218 - prefix	30"	(762)
	24" (610mm)	HB901224 - prefix	36"	(914)
	30" (762mm)	HB901230 - prefix	42"	(1067)
	36" (914mm)	HB901236 - prefix	48"	(1219)
24" (610mm)	06" (152mm)	HB902406 - prefix	30"	(762)
	09" (229mm)	HB902409 - prefix	33"	(838)
	12" (305mm)	HB902412 - prefix	36"	(914)
	18" (457mm)	HB902418 - prefix	42"	(1067)
	24" (610mm)	HB902424 - prefix	48"	(1219)
	30" (762mm)	HB902430 - prefix	54"	(1372)
	36" (914mm)	HB902436 - prefix	60"	(1524)
36" (914mm)	06" (152mm)	HB903606 - prefix	42"	(1067)
	09" (229mm)	HB903609 - prefix	45"	(1143)
	12" (305mm)	HB903612 - prefix	48"	(1219)
	18" (457mm)	HB903618 - prefix	54"	(1372)
	24" (610mm)	HB903624 - prefix	60"	(1524)
	30" (762mm)	HB903630 - prefix	66"	(1676)
	36" (914mm)	HB903636 - prefix	72"	(1829)

Application:
For Making 90 Deg.
turns on the same plan.

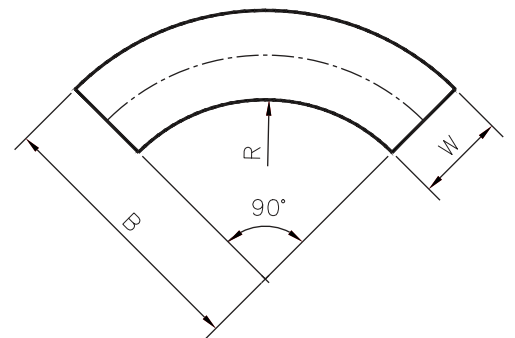

HB60

60 Deg Horizontal Elbow

Fitting Radius in (mm)	Width in (mm)	Part No Model no - Prefix	B	
			in	(mm)
12" (305mm)	06" (152mm)	HB60 1206 - prefix	18"	(457)
	09" (229mm)	HB60 1209 - prefix	21"	(533)
	12" (305mm)	HB60 1212 - prefix	24"	(610)
	18" (457mm)	HB60 1218 - prefix	30"	(762)
	24" (610mm)	HB60 1224 - prefix	36"	(914)
	30" (762mm)	HB60 1230 - prefix	42"	(1067)
	36" (914mm)	HB60 1236 - prefix	48"	(1219)
24" (610mm)	06" (152mm)	HB60 2406 - prefix	30"	(762)
	09" (229mm)	HB60 2409 - prefix	33"	(838)
	12" (305mm)	HB60 2412 - prefix	36"	(914)
	18" (457mm)	HB60 2418 - prefix	42"	(1067)
	24" (610mm)	HB60 2424 - prefix	48"	(1219)
	30" (762mm)	HB60 2430 - prefix	54"	(1372)
	36" (914mm)	HB60 2436 - prefix	60"	(1524)
36" (914mm)	06" (152mm)	HB60 3606 - prefix	42"	(1067)
	09" (229mm)	HB60 3609 - prefix	45"	(1143)
	12" (305mm)	HB60 3612 - prefix	48"	(1219)
	18" (457mm)	HB60 3618 - prefix	54"	(1372)
	24" (610mm)	HB60 3624 - prefix	60"	(1524)
	30" (762mm)	HB60 3630 - prefix	66"	(1676)
	36" (914mm)	HB60 3636 - prefix	72"	(1829)

Application:
For Making 60 Deg.
turns on the same plan.

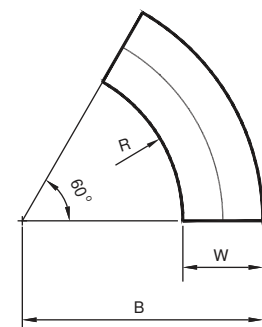
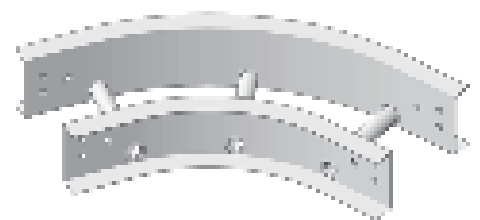

HT

Horizontal Tee

Fitting Radius	Width	Part No	A	B
12" (305mm)	06" (152mm)	HT 1206 - prefix	18" (457)	24" (610)
	09" (229mm)	HT 1209 - prefix	21" (533)	30" (762)
	12" (305mm)	HT 1212 - prefix	24" (610)	36" (914)
	18" (457mm)	HT 1218 - prefix	30" (762)	48" (1219)
	24" (610mm)	HT 1224 - prefix	36" (914)	60" (1524)
	30" (762mm)	HT 1230 - prefix	42" (1067)	72" (1829)
	36" (914mm)	HT 1236 - prefix	48" (1219)	84" (2134)
24" (610mm)	06" (152mm)	HT 2406 - prefix	30" (762)	36" (914)
	09" (229mm)	HT 2409 - prefix	33" (838)	42" (1067)
	12" (305mm)	HT 2412 - prefix	36" (914)	48" (1219)
	18" (457mm)	HT 2418 - prefix	42" (1067)	60" (1524)
	24" (610mm)	HT 2424 - prefix	48" (1219)	72" (1829)
	30" (762mm)	HT 2430 - prefix	54" (1372)	84" (2134)
	36" (914mm)	HT 2436 - prefix	60" (1524)	96" (2438)
36" (914mm)	06" (152mm)	HT 3606 - prefix	42" (1067)	48" (1219)
	09" (229mm)	HT 3609 - prefix	45" (1143)	54" (1372)
	12" (305mm)	HT 3612 - prefix	48" (1219)	60" (1524)
	18" (457mm)	HT 3618 - prefix	54" (1372)	72" (1829)
	24" (610mm)	HT 3624 - prefix	60" (1524)	84" (2134)
	30" (762mm)	HT 3630 - prefix	66" (1676)	96" (2438)
	36" (914mm)	HT 3636 - prefix	72" (1829)	108" (2743)

Application:
For Making right angle turns on the same plan. For branch to tray with narrower width than main tray, use reducers or consult factory.

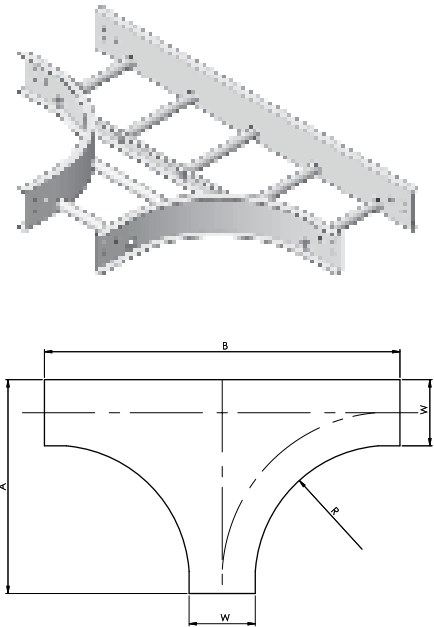

HC

Horizontal Cross

Fitting Radius	Width	Part No	B
12" (305mm)	06" (152mm)	HC 1206 - prefix	24" (610)
	09" (229mm)	HC 1209 - prefix	30" (762)
	12" (305mm)	HC 1212 - prefix	36" (914)
	18" (457mm)	HC 1218 - prefix	48" (1219)
	24" (610mm)	HC 1224 - prefix	60" (1524)
	30" (762mm)	HC 1230 - prefix	72" (1829)
	36" (914mm)	HC 1236 - prefix	84" (2134)
24" (610mm)	06" (152mm)	HC 2406 - prefix	36" (914)
	09" (229mm)	HC 2409 - prefix	42" (1067)
	12" (305mm)	HC 2412 - prefix	48" (1219)
	18" (457mm)	HC 2418 - prefix	60" (1524)
	24" (610mm)	HC 2424 - prefix	72" (1829)
	30" (762mm)	HC 2430 - prefix	84" (2134)
	36" (914mm)	HC 2436 - prefix	96" (2438)
36" (914mm)	06" (152mm)	HC 3606 - prefix	48" (1219)
	09" (229mm)	HC 3609 - prefix	54" (1372)
	12" (305mm)	HC 3612 - prefix	60" (1524)
	18" (457mm)	HC 3618 - prefix	72" (1829)
	24" (610mm)	HC 3624 - prefix	84" (2134)
	30" (762mm)	HC 3630 - prefix	96" (2438)
	36" (914mm)	HC 3636 - prefix	108" (2743)

Application:
For Making right angle turns on the same plan. For branch to tray with narrower width than main tray, use reducers or consult factory.

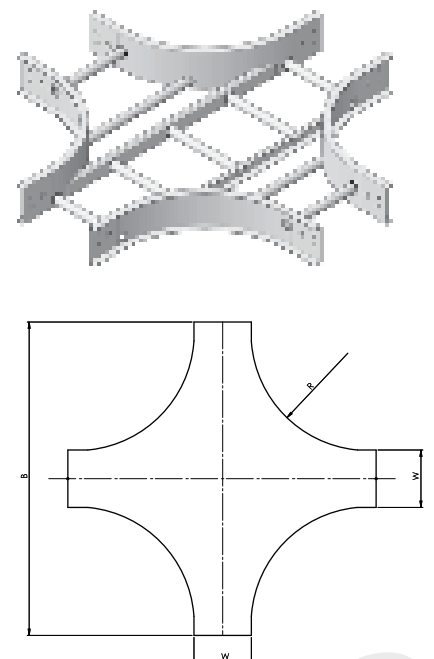

Application:

For 45 Deg. External corners or directional changes on a vertical plane.

Radius (R)	Load Depth (LD)		Part No Model no - Prefix	Width (w)	B	
	in	(mm)			in	(mm)
12" (305mm)	3"	(76mm)	VO45 12W3 - prefix	06"	10"	(254)
	4"	(102mm)	VO45 12W4 - prefix		10 3/8"	(264)
	5"	(127mm)	VO45 12W5 - prefix		10 6/8"	(273)
	6"	(152mm)	VO45 12W6 - prefix		11 1/8"	(283)
24" (610mm)	3"	(76mm)	VO45 24W3 - prefix	12"	18 4/8"	(470)
	4"	(102mm)	VO45 24W4 - prefix	18"	18 7/8"	(479)
	5"	(127mm)	VO45 24W5 - prefix	24"	19 2/8"	(489)
	6"	(152mm)	VO45 24W6 - prefix	36"	19 4/8"	(610)
36" (914mm)	3"	(76mm)	VO45 36W3 - prefix	36"	27"	(838)
	4"	(102mm)	VO45 36W4 - prefix		27 3/8"	(695)
	5"	(127mm)	VO45 36W5 - prefix		27 5/8"	(702)
	6"	(152mm)	VO45 36W6 - prefix		28"	(711)

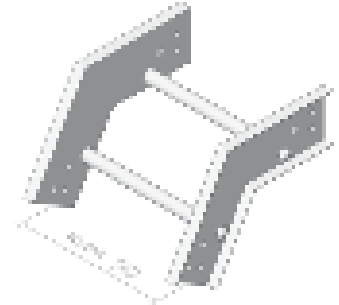

Application:

For 30 Deg. External corners or directional changes on a vertical plane.

Radius (R)	Load Depth (LD)		Part No Model no - Prefix	Width (W)	B	
	in	(mm)			in	(mm)
12" (305mm)	3"	(76mm)	VO30 12W3 - prefix	08"	7 1/8"	(181)
	4"	(102mm)	VO30 12W4 - prefix		7 3/8"	(187)
	5"	(127mm)	VO30 12W5 - prefix		7 5/8"	(194)
	6"	(152mm)	VO30 12W6 - prefix		7 7/8"	(200)
24" (610mm)	3"	(76mm)	VO30 24W3 - prefix	09"	13 1/8"	(333)
	4"	(102mm)	VO30 24W4 - prefix	12"	13 3/8"	(340)
	5"	(127mm)	VO30 24W5 - prefix	18"	13 5/8"	(346)
	6"	(152mm)	VO30 24W6 - prefix	24"	13 7/8"	(352)
36" (914mm)	3"	(76mm)	VO30 36W3 - prefix	36"	19 1/8"	(486)
	4"	(102mm)	VO30 36W4 - prefix		19 3/8"	(492)
	5"	(127mm)	VO30 36W5 - prefix		19 5/8"	(498)
	6"	(152mm)	VO30 36W6 - prefix		19 7/8"	(505)

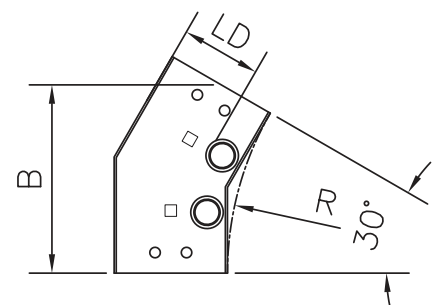
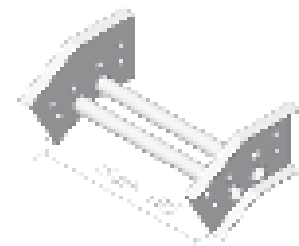

VO90

90 Deg Vertical Outside Elbow

Application:

For 90 Deg. External corners or directional changes on a vertical plane.

Radius (R) in (mm)	Load in	Depth (LD) (mm)	Part No Model no - Prefix	Width (W)	B in (mm)
12" (305mm)	3" (76mm)	VO90 12W3 - prefix	06", 09" 12", 18" 24", 36"	16 2/8" (413)	
	4" (102mm)	VO90 12W4 - prefix		17 2/8" (438)	
	5" (127mm)	VO90 12W5 - prefix		18 2/8" (464)	
	6" (152mm)	VO90 12W6 - prefix		19 2/8" (489)	
24" (610mm)	3" (76mm)	VO90 24W3 - prefix		28 2/8" (718)	
	4" (102mm)	VO90 24W4 - prefix		29 2/8" (743)	
	5" (127mm)	VO90 24W5 - prefix		30 2/8" (768)	
	6" (152mm)	VO90 24W6 - prefix		31 2/8" (794)	
36" (914mm)	3" (76mm)	VO90 36W3 - prefix		40 2/8" (1022)	
	4" (102mm)	VO90 36W4 - prefix		41 2/8" (1048)	
	5" (127mm)	VO90 36W5 - prefix		42 2/8" (1073)	
	6" (152mm)	VO90 36W6 - prefix		43 2/8" (1099)	

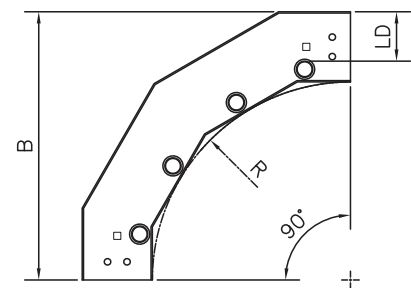
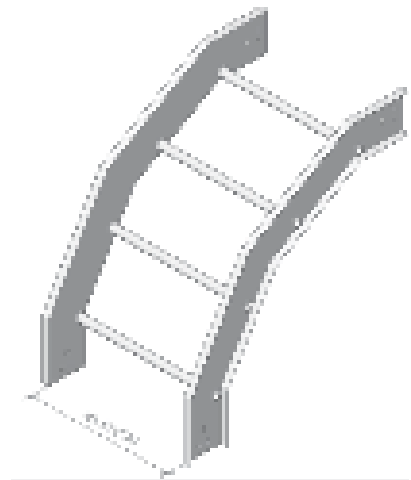

VO60

60 Deg Vertical Outside Elbow

Application:

For 60 Deg. External corners or directional changes on a vertical plane.

Radius (R) in (mm)	Load in	Depth (LD) (mm)	Part No Model no - Prefix	Width (W)	B in (mm)
12" (305mm)	3" (76mm)	VO6 12W3 - prefix	06", 09" 12", 18" 24", 36"	12 2/8" (311)	
	4" (102mm)	VO6 12W4 - prefix		12 5/8" (321)	
	5" (127mm)	VO6 12W5 - prefix		13 1/8" (333)	
	6" (152mm)	VO6 12W6 - prefix		13 4/8" (343)	
24" (610mm)	3" (76mm)	VO6 24W3 - prefix		22 5/8" (575)	
	4" (102mm)	VO6 24W4 - prefix		23 1/8" (587)	
	5" (127mm)	VO6 24W5 - prefix		23 4/8" (597)	
	6" (152mm)	VO6 24W6 - prefix		24" (610)	
36" (914mm)	3" (76mm)	VO6 36W3 - prefix		33" (838)	
	4" (102mm)	VO6 36W4 - prefix		33 4/8" (851)	
	5" (127mm)	VO6 36W5 - prefix		33 7/8" (860)	
	6" (152mm)	VO6 36W6 - prefix		34 3/8" (873)	

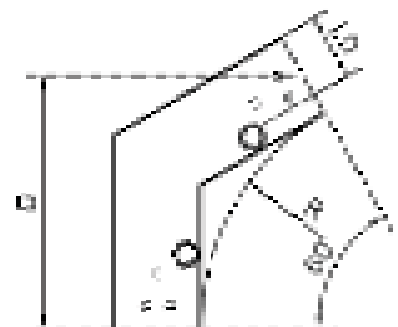
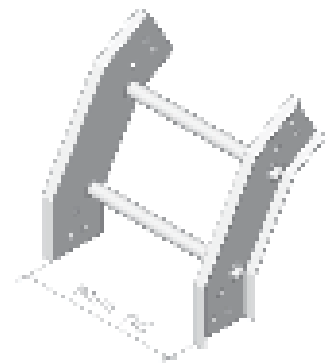

VI45

45 Deg Vertical Inside Elbow

Application:

For 45 Deg. Internal corners or directional changes on a vertical plane.

Radius (R) Width	Load Depth (LD)		Part No Model no - Prefix	Width (W)	B	
	in	(mm)			in	(mm)
12" (305mm)	3"	(76mm)	VI45 12W3 - prefix	06" , 09" 12" , 18" 24" , 36"	10"	(254)
	4"	(102mm)	VI45 12W4 - prefix		10 3/8"	(264)
	5"	(127mm)	VI45 12W5 - prefix		10 6/8"	(273)
	6"	(152mm)	VI45 12W6 - prefix		11 1/8"	(283)
24" (610mm)	3"	(76mm)	VI45 24W3 - prefix	18 4/8"	(470)	
	4"	(102mm)	VI45 24W4 - prefix	18 7/8"	(479)	
	5"	(127mm)	VI45 24W5 - prefix	19 2/8"	(489)	
	6"	(152mm)	VI45 24W6 - prefix	19 4/8"	(610)	
36" (914mm)	3"	(76mm)	VI45 36W3 - prefix	27"	(838)	
	4"	(102mm)	VI45 36W4 - prefix	27 3/8"	(695)	
	5"	(127mm)	VI45 36W5 - prefix	27 5/8"	(702)	
	6"	(152mm)	VI45 36W6 - prefix	28"	(711)	

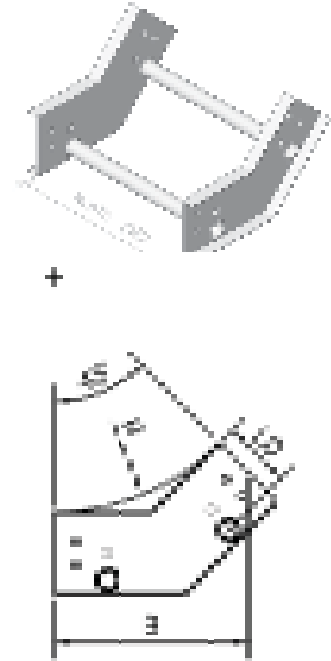

VI30

30 Deg Vertical Inside Elbow

Application:

For 30 Deg. Internal corners or directional changes on a vertical plane.

Radius (R) Width	Load Depth (LD)		Part No Model no - Prefix	Width (W)	B	
	in	(mm)			in	(mm)
12" (305mm)	3"	(76mm)	VI30 12W3 - prefix	06" , 09" 12" , 18" 24" , 36"	7 1/8"	(181)
	4"	(102mm)	VI30 12W4 - prefix		7 3/8"	(187)
	5"	(127mm)	VI30 12W5 - prefix		7 5/8"	(194)
	6"	(152mm)	VI30 12W6 - prefix		7 7/8"	(200)
24" (610mm)	3"	(76mm)	VI30 24W3 - prefix	13 1/8"	(333)	
	4"	(102mm)	VI30 24W4 - prefix	13 3/8"	(340)	
	5"	(127mm)	VI30 24W5 - prefix	13 5/8"	(346)	
	6"	(152mm)	VI30 24W6 - prefix	13 7/8"	(352)	
36" (914mm)	3"	(76mm)	VI30 36W3 - prefix	19 1/8"	(486)	
	4"	(102mm)	VI30 36W4 - prefix	19 3/8"	(492)	
	5"	(127mm)	VI30 36W5 - prefix	19 5/8"	(498)	
	6"	(152mm)	VI30 36W6 - prefix	19 7/8"	(505)	

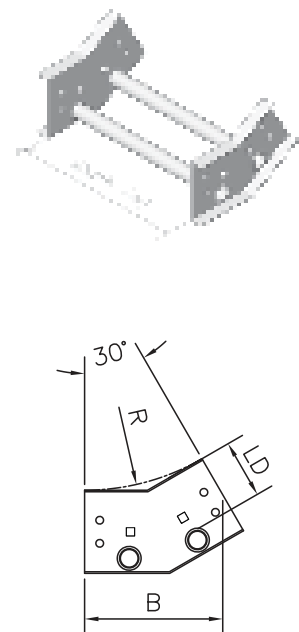

VI90

90 Deg Vertical Inside Elbow

Application:

For 90 Deg. Internal corners or directional changes on a vertical plane.

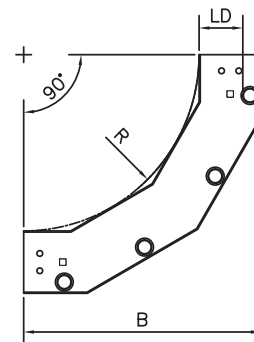
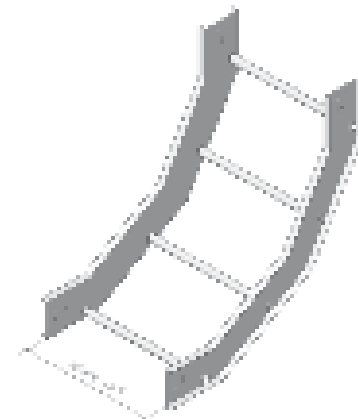

Radius (R) Width		Load Depth (LD)		Part No	Width (W)	B	
in	(mm)	in	(mm)	Model no - Prefix		in	(mm)
12" (305mm)		3" (76mm)		VI90 12W3 - prefix		16 2/8" (413)	
		4" (102mm)		VI90 12W4 - prefix		17 2/8" (438)	
		5" (127mm)		VI90 12W5 - prefix		18 2/8" (464)	
		6" (152mm)		VI90 12W6 - prefix		19 2/8" (489)	
24" (610mm)		3" (76mm)		VI90 24W3 - prefix	06" , 09"	28 2/8" (718)	
		4" (102mm)		VI90 24W4 - prefix	12" , 18"	29 2/8" (743)	
		5" (127mm)		VI90 24W5 - prefix	24" , 36"	30 2/8" (768)	
		6" (152mm)		VI90 24W6 - prefix		31 2/8" (794)	
36" (914mm)		3" (76mm)		VI90 36W3 - prefix		40 2/8" (1022)	
		4" (102mm)		VI90 36W4 - prefix		41 2/8" (1048)	
		5" (127mm)		VI90 36W5 - prefix		42 2/8" (1073)	
		6" (152mm)		VI90 36W6 - prefix		43 2/8" (1099)	

VI60

60 Deg Vertical Inside Elbow

Application:

For 60 Deg. Internal corners or directional changes on a vertical plane.

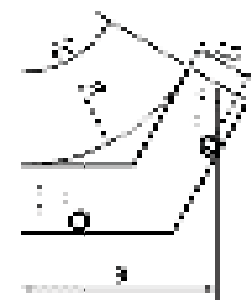
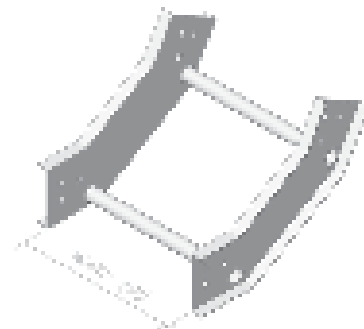

Radius (R) Width		Load Depth (LD)		Part No	Width (W)	B	
in	(mm)	in	(mm)	Model no - Prefix		in	(mm)
12" (305mm)		3" (76mm)		VI60 12W3 - prefix		12 2/8" (311)	
		4" (102mm)		VI60 12W4 - prefix		12 5/8" (321)	
		5" (127mm)		VI60 12W5 - prefix		13 1/8" (333)	
		6" (152mm)		VI60 12W6 - prefix		13 4/8" (343)	
24" (610mm)		3" (76mm)		VI60 24W3 - prefix	06" , 09"	22 5/8" (575)	
		4" (102mm)		VI60 24W4 - prefix	12" , 18"	23 1/8" (587)	
		5" (127mm)		VI60 24W5 - prefix	24" , 36"	23 4/8" (597)	
		6" (152mm)		VI60 24W6 - prefix		24" (610)	
36" (914mm)		3" (76mm)		VI60 36W3 - prefix		33" (838)	
		4" (102mm)		VI60 36W4 - prefix		33 4/8" (851)	
		5" (127mm)		VI60 36W5 - prefix		33 7/8" (860)	
		6" (152mm)		VI60 36W6 - prefix		34 3/8" (873)	

VT

Vertical Tee

Fitting Radius in (mm)	Width in (mm)	Part No Model no - Prefix	A		B	
			in (mm)	in (mm)	in (mm)	in (mm)
12" (305mm)	06" (152mm)	VT 1206 - prefix	24" (610)	18" (457)		
	09" (229mm)	VT 1209 - prefix	30" (762)	21" (533)		
	12" (305mm)	VT 1212 - prefix	36" (914)	24" (610)		
	18" (457mm)	VT 1218 - prefix	48" (1219)	30" (762)		
	24" (610mm)	VT 1224 - prefix	60" (1524)	36" (914)		
	30" (762mm)	VT 1230 - prefix	72" (1829)	42" (1067)		
24" (610mm)	36" (914mm)	VT 1236 - prefix	84" (2134)	48" (1219)		
	06" (152mm)	VT 2406 - prefix	36" (914)	30" (762)		
	09" (229mm)	VT 2409 - prefix	42" (1067)	33" (838)		
	12" (305mm)	VT 2412 - prefix	48" (1219)	36" (914)		
	18" (457mm)	VT 2418 - prefix	60" (1524)	42" (1067)		
	24" (610mm)	VT 2424 - prefix	72" (1829)	48" (1219)		
36" (914mm)	30" (762mm)	VT 2430 - prefix	84" (2134)	54" (1372)		
	36" (914mm)	VT 2436 - prefix	96" (2438)	60" (1524)		
	06" (152mm)	VT 3606 - prefix	48" (1219)	42" (1067)		
	09" (229mm)	VT 3609 - prefix	54" (1372)	45" (1143)		
	12" (305mm)	VT 3612 - prefix	60" (1524)	48" (1219)		
	18" (457mm)	VT 3618 - prefix	72" (1829)	54" (1372)		
36" (914mm)	24" (610mm)	VT 3624 - prefix	84" (2134)	60" (1524)		
	30" (762mm)	VT 3630 - prefix	96" (2438)	66" (1676)		
	36" (914mm)	VT 3636 - prefix	108" (2743)	72" (1829)		

Application:

For Making right angle turns on the vertical plan. For branch to tray with narrower width than main tray, use reducers or consult factory.

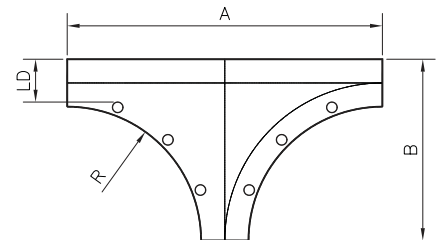
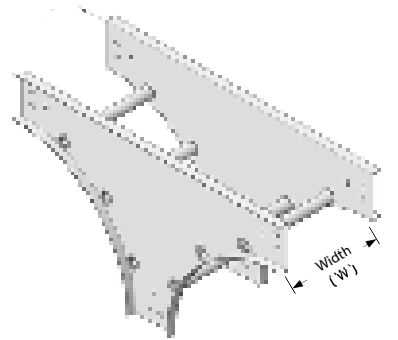

VS

Vertical Support Fitting

Application:

For 90 Deg. External corners or directional changes on a vertical plane.

Radius (R) Width	Load Depth (LD)		Part No Model no - Prefix	Width (W)		B
	in (mm)	in (mm)		in (mm)	in (mm)	
12" (305mm)	3" (76mm)	VS 12W3 - prefix			16 2/8" (413)	
	4" (102mm)	VS 12W4 - prefix			17 2/8" (438)	
	5" (127mm)	VS 12W5 - prefix			18 2/8" (464)	
	6" (152mm)	VS 12W6 - prefix			19 2/8" (489)	
24" (610mm)	3" (76mm)	VS 24W3 - prefix	06" , 09"		28 2/8" (718)	
	4" (102mm)	VS 24W4 - prefix	12" , 18"		29 2/8" (743)	
	5" (127mm)	VS 24W5 - prefix	24" , 36"		30 2/8" (768)	
	6" (152mm)	VS 24W6 - prefix			31 2/8" (794)	
36" (914mm)	3" (76mm)	VS 36W3 - prefix			40 2/8" (1022)	
	4" (102mm)	VS 36W4 - prefix			41 2/8" (1048)	
	5" (127mm)	VS 36W5 - prefix			42 2/8" (1073)	
	6" (152mm)	VS 36W6 - prefix			43 2/8" (1099)	

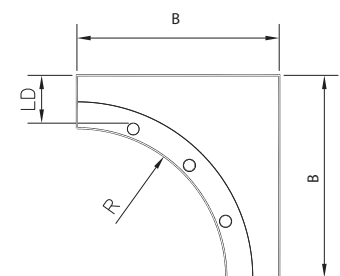
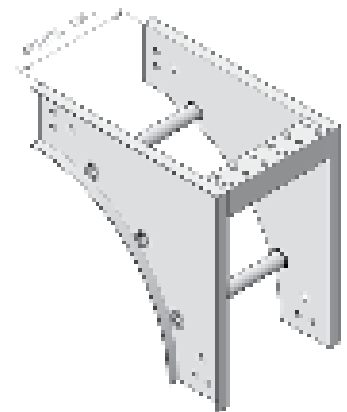

HYL&HYR

Horizontal -Y- (Left & Right)

Application:

For Making 45 Deg. angle turns on the same plan. For branch to tray with narrower width than main tray, use reducers or consult factory.

Type	Width		Part No Model no - Prefix	A		B	
	in	(mm)		in	(mm)	in	(mm)
Left Hand	06"	(152mm)	HYL 06 - prefix	22"	(552)	16"	(413)
	09"	(229mm)	HYL 09 - prefix	26"	(660)	21"	(543)
	12"	(305mm)	HYL 12 - prefix	30"	(768)	27"	(673)
	18"	(457mm)	HYL 18 - prefix	39"	(984)	37"	(933)
	24"	(610mm)	HYL 24 - prefix	47"	(1200)	47"	(1194)
	30"	(762mm)	HYL 30 - prefix	56"	(1416)	57"	(1454)
	36"	(914mm)	HYL 36 - prefix	64"	(1632)	68"	(1715)
Right Hand	06"	(152mm)	HYR 06 - prefix	22"	(552)	16"	(413)
	09"	(229mm)	HYR 09 - prefix	26"	(660)	21"	(543)
	12"	(305mm)	HYR 12 - prefix	30"	(768)	27"	(673)
	18"	(457mm)	HYR 18 - prefix	39"	(984)	37"	(933)
	24"	(610mm)	HYR 24 - prefix	47"	(1200)	47"	(1194)
	30"	(762mm)	HYR 30 - prefix	56"	(1413)	57"	(1454)
	36"	(914mm)	HYR 36 - prefix	64"	(1632)	68"	(1715)

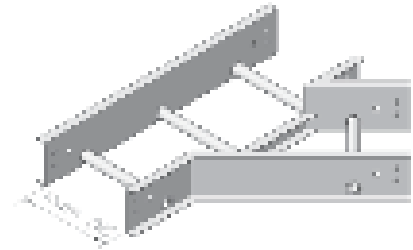

Right Hand (HYR) Type

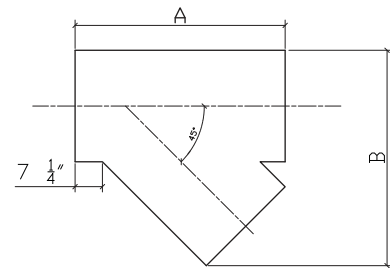

AHB

Adjustable Horizontal Elbow

Application:

For changing the direction of a cable tray system at angles other than those provided by fixed elbows. Providing angular adjustment in a range 30° to 90°. For angles less than 30 deg, Consult Factory.

Width (W)	Load Depth (LD)	
in	(mm)	Model no - Prefix
06"	(152mm)	AHB 06 - prefix
09"	(229mm)	AHB 09 - prefix
12"	(305mm)	AHB 12 - prefix
18"	(457mm)	AHB 18 - prefix
24"	(610mm)	AHB 24 - prefix
30"	(762mm)	AHB 30 - prefix
36"	(914mm)	AHB 36 - prefix

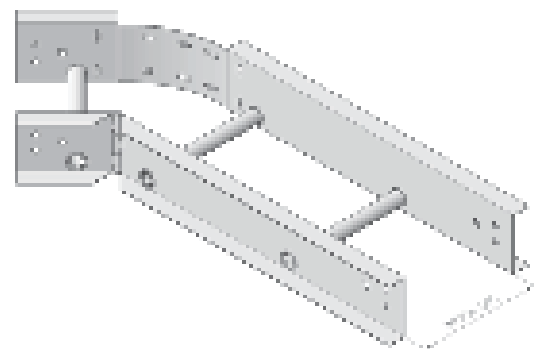

RS Straight Reducer

Application:

For gradually reducing the size of tray both sides.

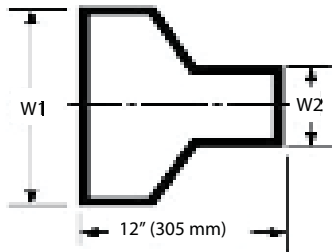
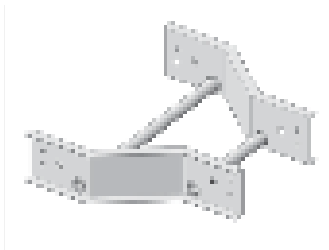

RR Right Hand Reducer

Application:

For gradually reducing the size of tray from right side.

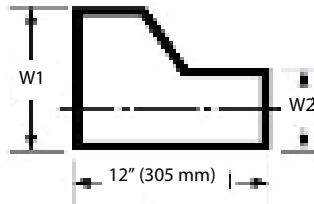
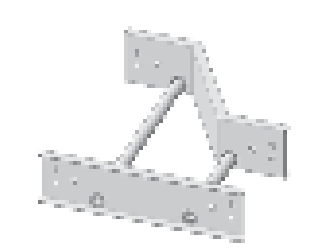

RL Left Hand Reducer

Application:

For gradually reducing the size of tray from left side.

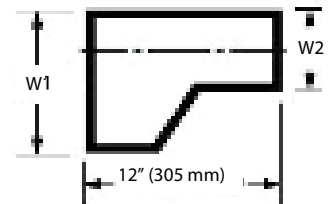
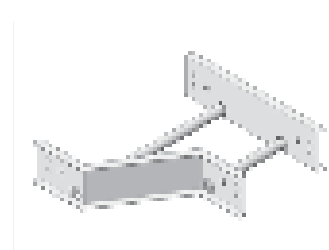

RS: Straight Reducer

RR: Right Hand Reducer

RL: Left Hand Reducer

Width (W1) in (mm)	Width (W2) V		Part No		Part No	
	in	(mm)	Model no - Prefix	Model no - Prefix	Model no - Prefix	Model no - Prefix
36" (914mm)	06"	(152mm)	RS 3606 - prefix	RR 3606 - prefix	RL 3606 - prefix	
	09"	(229mm)	RS 3609 - prefix	RR 3609 - prefix	RL 3609 - prefix	
	12"	(305mm)	RS 3612 - prefix	RR 3612 - prefix	RL 3612 - prefix	
	18"	(457mm)	RS 3618 - prefix	RR 3618 - prefix	RL 3618 - prefix	
	24"	(610mm)	RS 3624 - prefix	RR 3624 - prefix	RL 3624 - prefix	
	30"	(762mm)	RS 3630 - prefix	RR 3630 - prefix	RL 3630 - prefix	
30" (762mm)	06"	(152mm)	RS 3006 - prefix	RR 3006 - prefix	RL 3006 - prefix	
	09"	(229mm)	RS 3009 - prefix	RR 3009 - prefix	RL 3009 - prefix	
	12"	(305mm)	RS 3012 - prefix	RR 3012 - prefix	RL 3012 - prefix	
	18"	(457mm)	RS 3018 - prefix	RR 3018 - prefix	RL 3018 - prefix	
	24"	(610mm)	RS 3024 - prefix	RR 3024 - prefix	RL 3024 - prefix	
24" (610mm)	06"	(152mm)	RS 2406 - prefix	RR 2406 - prefix	RL 2406 - prefix	
	09"	(229mm)	RS 2409 - prefix	RR 2409 - prefix	RL 2409 - prefix	
	12"	(305mm)	RS 2412 - prefix	RR 2412 - prefix	RL 2412 - prefix	
	18"	(457mm)	RS 2418 - prefix	RR 2418 - prefix	RL 2418 - prefix	
18" (457mm)	06"	(152mm)	RS 1806 - prefix	RR 1806 - prefix	RL 1806 - prefix	
	09"	(229mm)	RS 1809 - prefix	RR 1809 - prefix	RL 1809 - prefix	
	12"	(305mm)	RS 1812 - prefix	RR 1812 - prefix	RL 1812 - prefix	
12" (305mm)	06"	(152mm)	RS 1206 - prefix	RR 1206 - prefix	RL 1206 - prefix	
	09"	(229mm)	RS 1209 - prefix	RR 1209 - prefix	RL 1209 - prefix	
09" (229mm)	06"	(152mm)	RS 0906 - prefix	RR 0906 - prefix	RL 0906 - prefix	

USC Universal Splice Connector

- Supplied in Pairs and have hole pattern which match the tray system.
- Hardware to be ordered separately.
- For field installation drill 13/32" hole.
- Tighten with enough torque approx.(22 ft/lbs).

Load Depth	Catalogue No
3" (76 mm)	USC3 - M/F
4" (102 mm)	USC4 - M/F
5" (127 mm)	USC5 - M/F
6" (152 mm)	USC6 - M/F



M/F : Denotes Material/Finishing

EPC Expansion Plate Connector

- Expansion plate provides one inch expansion or contraction of cable tray as per NEMA VE-1
- Supplied in Pairs, Hardware to be ordered separately.
- Tighten lock nut just enough to allow movement along the slot.
- Bonding Jumper required, To be ordered separately.

Load Depth	Catalogue No
3" (76 mm)	EPC3 - M/F
4" (102 mm)	EPC4 - M/F
5" (127 mm)	EPC5 - M/F
6" (152 mm)	EPC6 - M/F

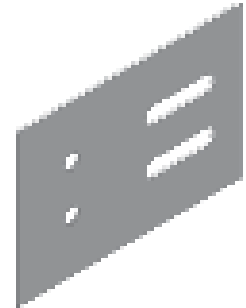

M/F : Denotes Material/Finishing

VAC Vertical Adjustable Connector

- Required to provide change in elevation where standard vertical fittings do not apply.
- Supplied in Pairs ,Hardware to be ordered separately.
- Bonding Jumper required, To be ordered separately.

Load Depth	Catalogue No
3" (76 mm)	VAC3 - M/F
4" (102 mm)	VAC4 - M/F
5" (127 mm)	VAC5 - M/F
6" (152 mm)	VAC6 - M/F

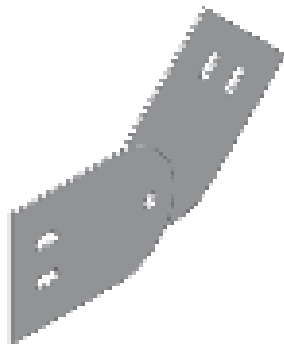

M/F : Denotes Material/Finishing

HAC Horizontal Adjustable Connector

- Required to provide change direction in horizontal plan where standard horizontal fittings do not apply.
- Supplied in Pairs ,Hardware to be ordered separately.
- Bonding Jumper required, To be ordered separately.

Load Depth	Catalogue No
3" (76 mm)	HAC3 - M/F
4" (102 mm)	HAC4 - M/F
5" (127 mm)	HAC5 - M/F
6" (152 mm)	HAC6 - M/F

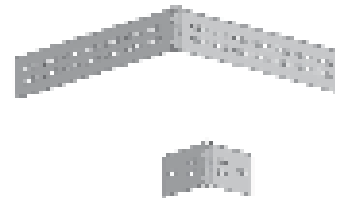

M/F : Denotes Material/Finishing

ACC 90 Deg Angle Connector

- Required to connect cable trays for 90 Deg. Direction in limited radius area or to connect to panel or box.
- Supplied in Pairs .
- Hardware to be ordered separately

Load Depth	Catalogue No
3" (76 mm)	ACC3 - M/F
4" (102 mm)	ACC4 - M/F
5" (127 mm)	ACC5 - M/F
6" (152 mm)	ACC6 - M/F

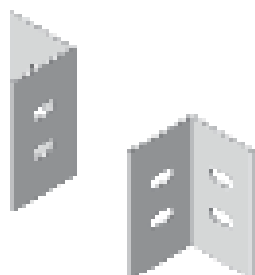

M/F : Denotes Material/Finishing

SDC Step Down Connector

- Required to connect cable trays of different side rail Height.
- Supplied in Pairs .
- Hardware to be ordered separately

Load Depth	Catalogue No
3" (76 mm)	SDC - LD1/LD2 - M/F
4" (102 mm)	SDC - LD1/LD2 - M/F
5" (127 mm)	SDC - LD1/LD2 - M/F
6" (152 mm)	SDC - LD1/LD2 - M/F

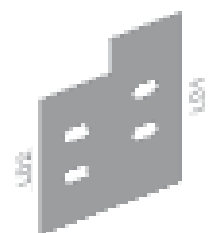

M/F : Denotes Material/Finishing

BPC

Branch Pivot Connector

- Required to form branch from cable tray run at any point.
- Supplied in Pairs ,Hardware to be ordered seperately.
- Bonding Jumper required, To be ordered seperately.

Load Depth Catalogue No

3" (76 mm)	BPC3-M/F
4" (102 mm)	BPC4-M/F
5" (127 mm)	BPC5-M/F
6" (152 mm)	BPC6-M/F

On order state :
M/F : Denotes Material/Finishing



BEC

Blind End Plate

- Required to form closure for dead end of cable tray .
- Hardware to be ordered separately.

Load Depth Catalogue No

3" (76 mm)	BEC3-W-M/F
4" (102 mm)	BEC4-W-M/F
5" (127 mm)	BEC5-W-M/F
6" (152 mm)	BEC6-W-M/F

On order state :
W : Denotes Cable Tray Width
M/F : Denotes Material/Finishing

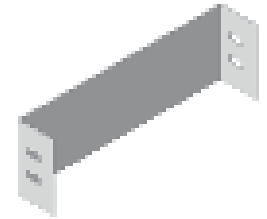

RPC

Reducing Plate Connector

- Required to join cable trays with different widths
- Supplied in Pairs ,Hardware to be ordered separately.

Load Depth Catalogue No

3" (76 mm)	RPC3-W1/W2-M/F
4" (102 mm)	RPC4-W1/W2-M/F
5" (127 mm)	RPC5-W1/W2-M/F
6" (152 mm)	RPC6-W1/W2-M/F

On order state :
W : Denotes Width Reduction
M/F : Denotes Material/Finishing

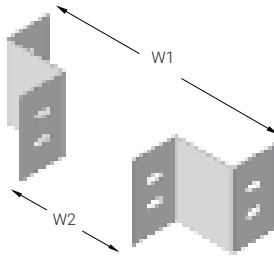

ORC

Offset Reducing Connector

- Required for offset reduction (left hand or right hand) of defferent width cable trays.
- Supplied in Pairs ,Hardware to be ordered separately.

Load Depth Catalogue No

3" (76 mm)	ORC3-W1/W2-M/F
4" (102 mm)	ORC4-W1/W2-M/F
5" (127 mm)	ORC5-W1/W2-M/F
6" (152 mm)	ORC6-W1/W2-M/F

On order state :
W : Denotes Width Reduction
M/F : Denotes Material/Finishing

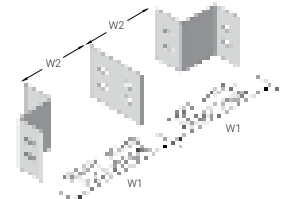

TBC

Tray To Box Connector

- Required to fix the end of cable tray distribution box .
- Hardware to be ordered seperately.

Load Depth Catalogue No

3" (76 mm)	TBC3-W-M/F
4" (102 mm)	TBC4-W-M/F
5" (127 mm)	TBC5-W-M/F
6" (152 mm)	TBC6-W-M/F

On order state :
W : Denotes Width Reduction
M/F : Denotes Material/Finishing

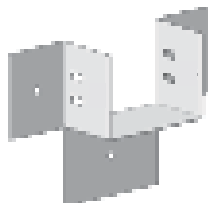

DOP

Drop Out Plate

- Required to exit cables from cable tray on round smooth piece to prevent damage of cable insulation.
- Bend radius is 4" (102 mm).
- Can be fixed on any rung along the tray.

Catalogue No

DOP-W-MIF

On order state :
W : Denotes Width Reduction
M/F : Denotes Material/Finishing

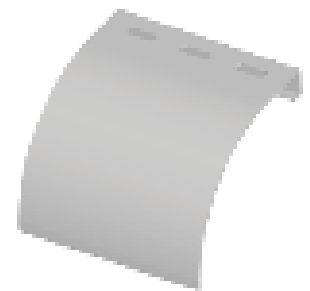

SBS

Barrier Strip Straight

Load Depth (LD) in (mm)	Part No
3" (76mm)	SBS3-M/F
4" (102mm)	SBS4-M/F
5" (127mm)	SBS5-M/F
6" (152mm)	SBS6-M/F

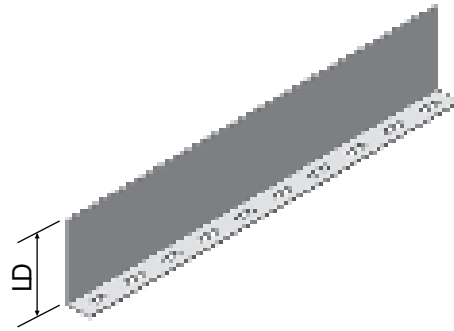

SBHF

Barrier Strip Horizontal Fitting

Load Depth (LD) in (mm)	Part No
3" (76mm)	SBHF3-M/F
4" (102mm)	SBHF4-M/F
5" (127mm)	SBHF5-M/F
6" (152mm)	SBHF6-M/F

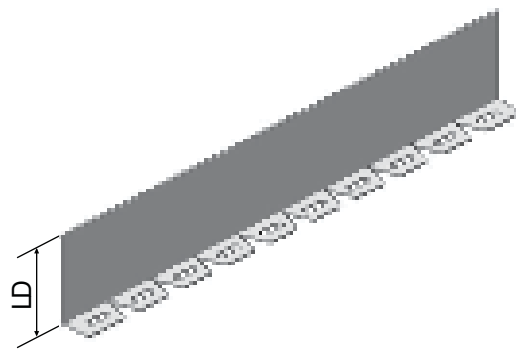

SBVF

Barrier Strip Vertical Fitting

Radius (R) Width in (mm)	Load Depth (LD) in (mm)	Part No
12" (305mm)	3" (76mm)	SBVF-3-24-M/F
	4" (102mm)	SBVF-4-12-M/F
	5" (127mm)	SBVF-5-12-M/F
	6" (152mm)	SBVF-6-12-M/F
24" (610mm)	3" (76mm)	SBVF-3-12-M/F
	4" (102mm)	SBVF-4-24-M/F
	5" (127mm)	SBVF-5-24-M/F
	5" (127mm)	SBVF-5-36-M/F
36" (914mm)	3" (76mm)	SBVF-3-36-M/F
	4" (102mm)	SBVF-4-36-M/F
	5" (127mm)	SBVF-5-36-M/F
	6" (152mm)	SBVF-6-36-M/F

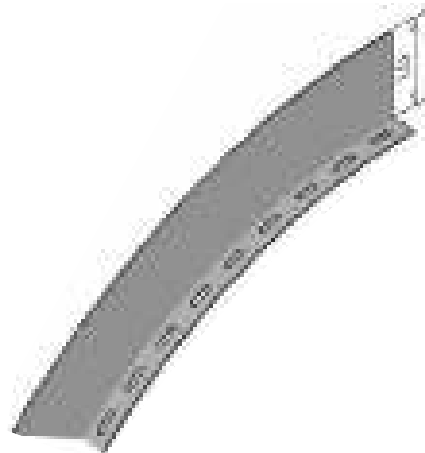

SBSC

Barrier Strip Clamp Assembly

Load Depth (LD) in (mm)	Part No
3" (76mm)	SBSC3-M/F
4" (102mm)	SBSC4-M/F
5" (127mm)	SBSC5-M/F
6" (152mm)	SBSC6-M/F

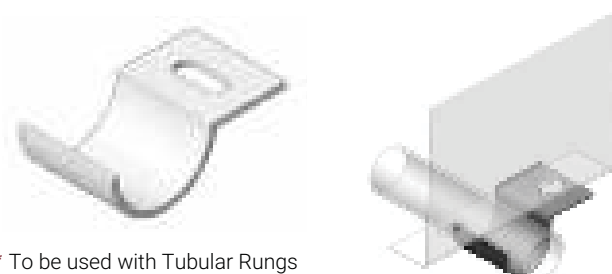

* To be used with Tubular Rungs

CHS Connector Hardware

- Ribbed neck screw with Phillips slot.
- Size: 3/8" Dia.
- Nut with serrated face, no washer required.



Item	Catalogue No
------	--------------

Screw + Nut CHS-M/F

On order state :
M/F : Denotes Material/Finishing
GS : Electro galvanized
HG: Hot dip Galvanized
SS6: Stainless Steel 316
SS4: Stainless Steel 304

HDC Hold Down Clamp

- For use with all type of ladders
- Supplied in Pairs.
- Hardware, 3/8", to be ordered separately

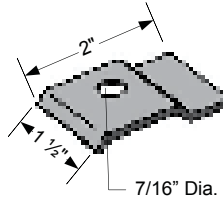

Catalogue No

HDC-M/F

On order state :
M/F : Denotes Material/Finishing

EGC Expansion Guide

- For use with all type of ladders
- Supplied in Pairs.
- Hardware, 3/8", to be ordered separately

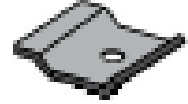

Catalogue No

EGC - M/F

On order state :
M/F : Denotes Material/Finishing

IDC Internal Hold Down

- For use mainly with through type tray
- and also for holding ladder from inside.
- Supplied in Pairs.
- Hardware, 3/8", to be ordered separately

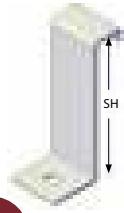

Load Depth	Catalogue No
------------	--------------

3" (76 mm) IDC3 - M/F

4" (102 mm) IDC4 - M/F

5" (127 mm) IDC5 - M/F

6" (152 mm) IDC6 - M/F

M/F : Denotes Material/Finishing

VHC Vertical Hold Clamp

- For use with Vertical installation of cable ladder.
- Supplied in Pairs.
- Hardware For Tray attachment 3/8", and 1/2" support hardware to be ordered separately

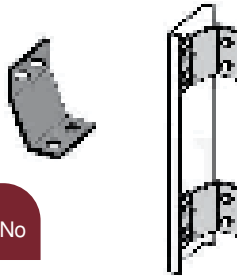

Catalogue No

VHC-M/F

M/F : Denotes Material/Finishing

IHC I-Beam Hold Clamp

- For use on I-Beam structure without drillings
- Supplied in Pairs.
- Hardware Included
- Remove upper hardware to use as guide clamp

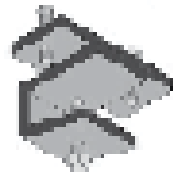

Catalogue No

IHC-M/F

M/F : Denotes Material/Finishing

BJ Bonding Jumper

For use to maintain electrical continuity to ground, to be used with expansion and adjustable connectors.



Type	Size & AMP	Catalogue No.
------	------------	---------------

BJS 600A. BJS-6

1600A. BJS-16

BJI 1/0 (800 A) BJI - 8

4/0 (1600 A) BJI - 16

GWC Ground Wire Clip

- For use to hold to tray side rail one or two bare copper or aluminum conductors
- Supplied in pieces .
- Hardware For Tray attachment 3/8" to be ordered separately



Cond. Size	Catalogue No
------------	--------------

no. 1 to 2/0 GWC - 1

3/0 to 4/0 GWC - 2

M/F : Denotes Material/Finishing

A wide variety of covers which can be used horizontal and vertical runs to provide protection for cables installed in cable trays against environmental effects, sunlight and dirt. All covers are designed and fabricated to meet indoor and outdoor applications. Straight covers supplied are 10 and 12 ft. long. All standard cover fittings are flat solid type.

Material :

- (HR) Hot rolled Steel sheet : to ASTM A 36
- (PG) Pregalvanized Steel : to ASTM A-653 G90
- (AL) Aluminum : AA 3150 - H14
- (SS) Stainless Steel : to ASTM A240
(Type 304 & 316)

Finishes :

- (HDG): Hot Dip Galvanized To ASTM A123(BS EN1461)
- (ZP): Zinc Plating To ASTM B633.
- (EP): Epoxy Painted.
- (PC): Electrostatic Industrial Powder Coating.

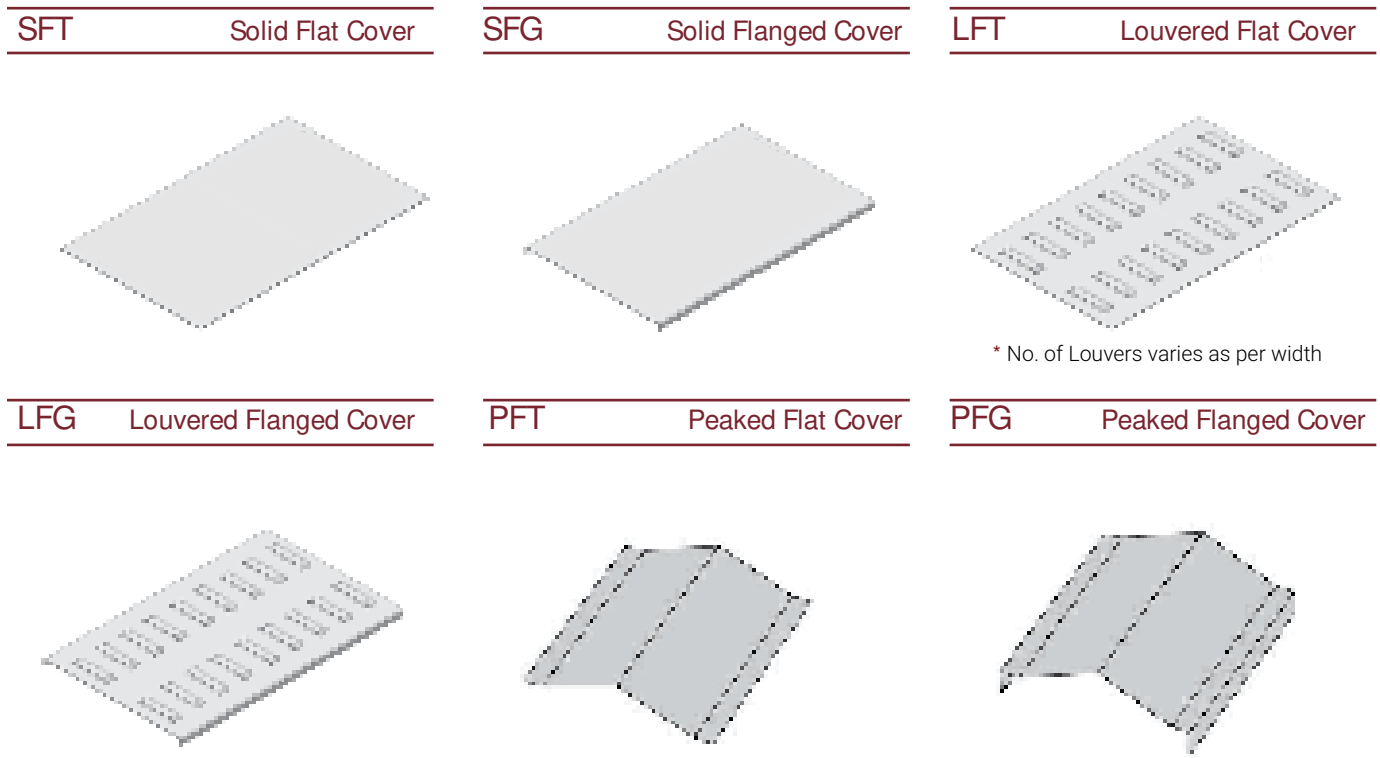

* No. of Louvers varies as per width

* No. of Louvers varies as per width

Straight Covers Ordering Way :

FIN SFT - 18 - 12 - AL

Ladder Type	Name Class	Width	Length	Material/Finish.
FIN : Flange Inside	SFT	152 mm (06")	3.0 mtr (10')	PG: Pre galvanized Steel
FOT : Flange Outside	SFG	229 mm (09")	3.7 mtr (12')	HG: Hot Dip Galvanized
	LFT	305 mm (12")		AL: Aluminum
	LFG	457 mm (18")		S4: Stainless Steel 304
	PFT	610 mm (24")		S6: Stainless Steel 316
	PFG	762 mm (30")		CA: Corten-A Steel
		914 mm (36")		HP: Hot Dip Galvanized & Powder Coated

Quantity of Standard Cover Clamps Required:

Straight Section 60" or 72"..... 4 pcs.
 Horizontal/Vertical Bends 4 pcs.
 Crosses 8 pcs.

Straight Section 120" or 144".....6 pcs.
 Tees.....6 pcs.

Material :

(HR) Hot rolled Steel sheet : to ASTM A 36
 (PG) Pregalvanized Steel: to ASTM A-653 G90
 (AL) Aluminum : AA 3150 - H14
 (SS) Stainless Steel : to ASTM A240
 (Type 304 & 316)

Finishes :

(HDG): Hot Dip Galvanized To ASTM A123(BS EN1461)
 (ZP): Zinc Plating To ASTM B633.
 (EP): Epoxy Painted.
 (PC): Electrostatic Industrial Powder Coating.

FSC Fixing screws

- Screws, self-drilling and lapping, provide economical cover hold-down for trays with intumed flanges. Recommended installation:8 screws for each 12 foot section. Zinc plated Steel.

Catalogue No
 FSC-M/F



FCC Cover Clamp

- For indoor Installation Only.

Catalogue No
 FCC-M/F

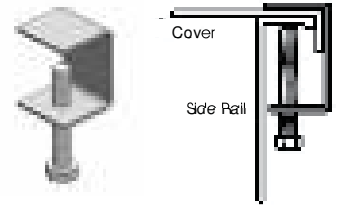

DCC Double Connector Clamp

- Recommended for outdoor service
- Insert Tray Width

Load Depth	Catalogue No
3" (76 mm)	DCC3 - M/F
4" (102 mm)	DCC4 - M/F
5" (127 mm)	DCC5 - M/F
6" (152 mm)	DCC6 - M/F

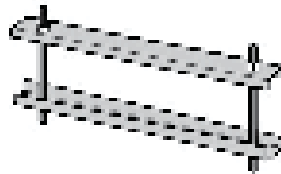

Insert tray width

WCC Wraparound Cover Clamp

- Recommended for outdoor service
- Insert Tray Width

Load Depth	Catalogue No
3" (76 mm)	WCC3 - M/F
4" (102 mm)	WCC4 - M/F
5" (127 mm)	WCC5 - M/F
6" (152 mm)	WCC6 - M/F

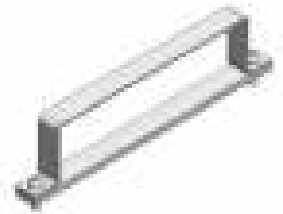

RCC Raised Cover Clamp

- Specify gap of 1", 2", 3" or 4".

Catalogue No
 RCC-M/F

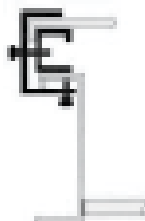

M/F : Denotes Material/Finishing

WPC Wraparound Peaked Cover Clamp

- Recommended for outdoor service
- Insert Tray Width

Load Depth	Catalogue No
3" (76 mm)	WPC3 - M/F
4" (102 mm)	WPC4 - M/F
5" (127 mm)	WPC5 - M/F
6" (152 mm)	WPC6 - M/F

