



Efficient Illumination, Enduring Safety

INDUSTRIAL LIGHTING

Go beyond illumination

More than

MILLION

light points across india
for industrial workspaces

More than

4 DECADES

of presence
in Industrial Lighting

Lighting solutions

DESIGNED

to meet varied industrial
segments & environments



9 Legacy
of
Decades



Inhouse R&D
Facilities
along with
Manufacturing
Facilities



Concept
to Care

ENSURING THE BEST FIT INDUSTRIAL LIGHTING SYSTEM

Creating a good Industrial Lighting system involves careful consideration of various parameters. Lighting Designer should take into account the operating conditions of the site, application and the visual tasks for which illumination is required. Selecting the appropriate luminaire for an industrial space involves considering several factors to ensure optimal lighting performance.

Important aspects that a lighting designer considers to arrive at Best Fit lighting solutions include -



LIGHTING NEEDS OF THE VISUAL TASK

Understand the specific lighting needs of the industrial space. Type of tasks performed and importance of the visual task decides required light levels. One should also consider any specific lighting regulations or standards required for the given application area.



SPACE LAYOUT AND DESIGN

Consider the layout and dimensions of the industrial space. This includes ceiling height, the presence of obstacles or machineries, and the arrangement of work areas. These factors determine the placement and type of luminaires needed. One should also consider the passage ways and emergency exits while selecting the luminaire.

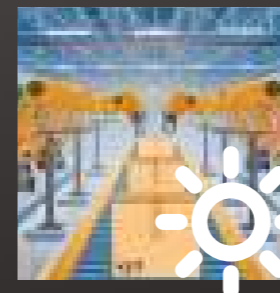

LUMEN OUTPUT AND DISTRIBUTION

Determine the required lumen output of luminaire to achieve the desired light levels in the industrial space. Consider the beam angle and light distribution pattern of the luminaire to ensure uniform lighting across the area.



DURABILITY AND PROTECTION

Industrial environments can be harsh, with factors like dust, moisture, and vibrations. Select luminaires that are designed to withstand these conditions and have appropriate IP (Ingress Protection) ratings to ensure necessary protection.

By carefully considering these factors, you can select the most suitable luminaires for your industrial space, providing optimal lighting conditions for productivity, safety, and energy efficiency. It is recommended to consult with lighting professionals or manufacturers for expert guidance in luminaire selection.



ENERGY EFFICIENCY

Opt for luminaires with high energy efficiency ratings to reduce electricity consumption and operating costs.



EASE OF MAINTENANCE

Luminaire designs that ensure ease of maintenance are very important for users as it reduces downtime in case of failures.

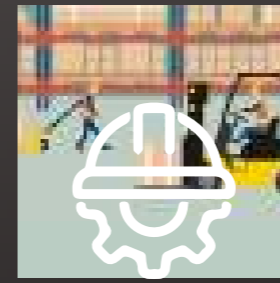

COMPLIANCE AND SAFETY

Ensure that the selected luminaires comply with relevant safety standards and regulations for industrial spaces. This includes factors like electrical safety, fire codes, and hazardous area requirements.

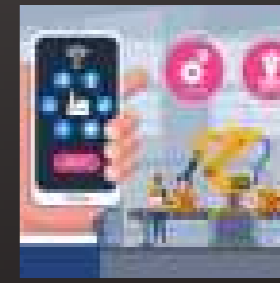

SMART LIGHTING OPTIONS

Industrial workspaces are now adopting smart controls in managing the lighting systems. Efficient use of day light harvesting, motion sensors and monitoring systems are being used in sync with the luminaires installed in the work area.

Important specifications that an industrial user needs to check while deciding the best-fit luminaire for the application area.



	Features :	Designer's Checklist :
	Applications	Standard Industrial Workspace, Hazardous or Non-hazardous area, Clean Room area, High temp zones, areas with high dust or water splashing, semi outdoor
	Type of Luminaire	Highbay – Midbay, Wellglass, Cleanroom, IP65 Batten.
	Height of the Installation	Depending on the height of light point installation, we decide to use suitable luminaire like Wellglass, Midbay/Highbay and Wattages.
	Type of Mounting	Eye Bolt, Trunk Mounting, Mounting Bracket, Recess, Surface.
	Lumens Required	Depending on the visual task, designer ascertains the required Lux levels and required lumen output of luminaires.
	Efficacy	System lumen/watt required.
	IP Rating	IP20 / IP65 / IP66 depending on application area environment IP rating is decided.
	CCT	Warm White / Neutral White / Cool Day White (3000/4000/ 5700/6500). Standard colour temperature used in industrial workspace is 5700K. In few dusty areas, users prefer warm white options.
	CRI	70 is standard for most industrial applications. When color of the visual task is more important customers go for CRI 80.
	Surge Protection	Most industrial luminaires have built in surge protection of 3 kv/4kv . In specific cases , we can also provide external surge protection of 10kV SPD.
	Beam Angle	600 or Narrow Beam for high ceiling areas and 900 or wide beam for low height areas.

INDUSTRIAL LIGHTING SEGMENTS



1  Warehouse & Logistics

2  Steel & Metal Manufacturer

3  Power & Infrastructure

4  Auto & Ancillary

5  METROS & Railway

6  Pharma & Healthcare

THE FOURTH INDUSTRIAL REVOLUTION

At Bajaj Electricals, we are continuously innovating to help our clients successfully deliver Industry 4.0 goals. Our products are now Industry 4.0 Ready and our Bajaj SynChronus platform helps customer improve productivity and energy savings



INDUSTRIAL Revolution

The First Industrial Revolution 1.0, which began in the 18th century with the use of steam power and mechanization. This saw the rise of large-scale industries such as textiles, iron, and coal mining. The Technological Revolution, also known as the second industrial revolution, began in the 19th century with the discovery of electricity and assembly line production. This brought about mass production in industries such as automobiles. The third industrial revolution was the advent of the Digital Revolution, which began in the 1970s with partial automation using memory-programmable controls and computers. This introduced automation in industries such as electronics. The journey further continues to connected solutions.



INDUSTRY 4.0 Connected Industry

In the era of Industry 4.0, also known as the fourth industrial revolution, the fusion of human expertise with digitally-driven machinery and advanced connectivity revolutionizes manufacturing. People play a central role, empowered by software systems that streamline their tasks to unprecedented levels.

This seamless integration extends across the entire value chain, where every object in production or use boasts unique identification and autonomous communication capabilities. Vertical information flows span from individual components to the company's IT platform, while horizontal communication links machines within production and the broader manufacturing ecosystem.

Introducing **SYNCHRONOUS**

ACHIEVING INDUSTRY 4.0 GOALS WITH SMART LIGHTING SOLUTIONS

With the Bajaj Synchronous system, your evolving needs always find the perfect solution. It's three-layered offering offers flexibility, easily upgradable with new hardware or software. As your system expands, rest assured—every previously installed light point remains an integral part of the seamless progression. Your smart lighting journey is not just a path; it's a continuum of possibilities.

Bajaj Synchronous shall help customers embark on the journey to achieve their Industry 4.0 goals efficiently.

SYNCHRONOUS ...PREMIUM



Occupancy Analytics



Multiple Sites Access



Workspace Quality Analytics



BMS Integration



SYNCHRONOUS ...PRO



Cloud Integration



Scene Manager



Remote Site Management



Data Rich Dashboard



Predictive Maintenance



SYNCHRONOUS ...FOUNDATION



Sensor Integration



Seamless Connectivity on BLE



Greenfield & Retrofit Ready



Simple Setup



Energy Savings

SYSTEM ARCHITECTURE

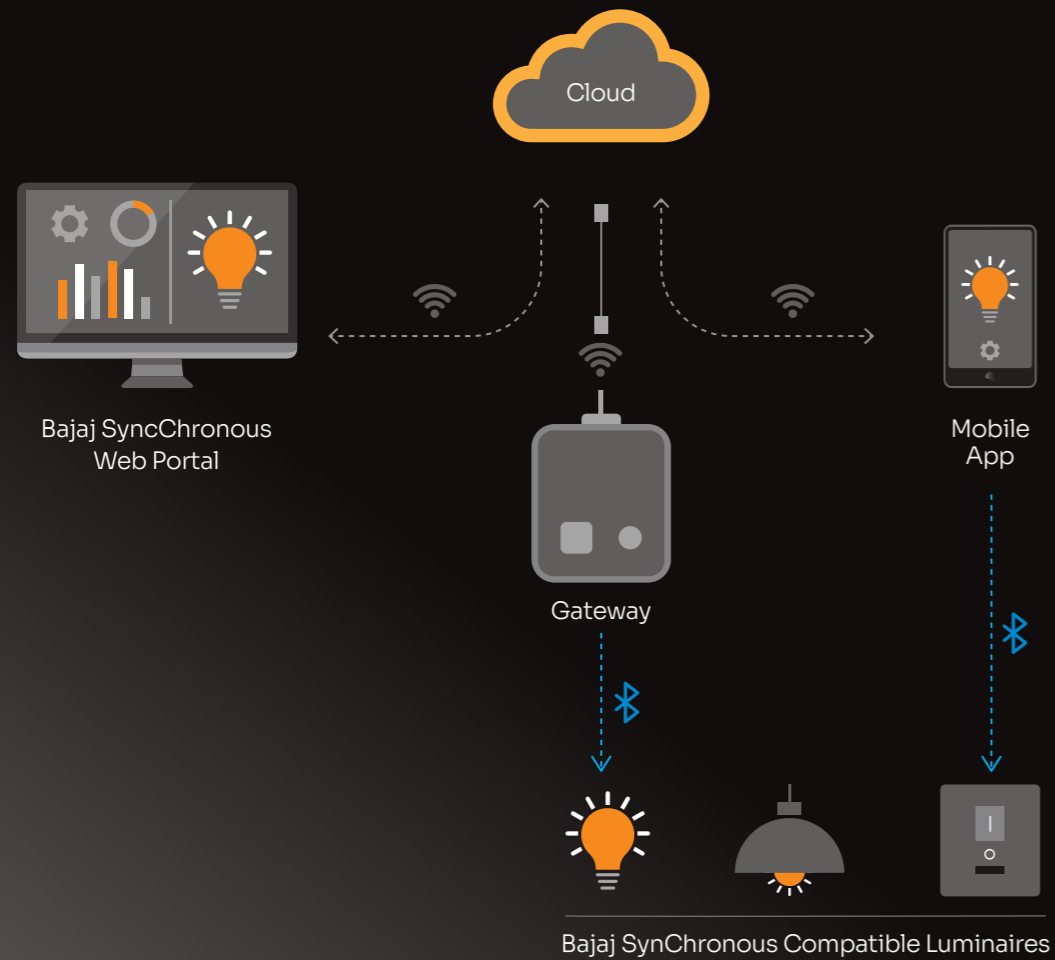

INSTALL IN A SNAP!

PLANNING



SETUP

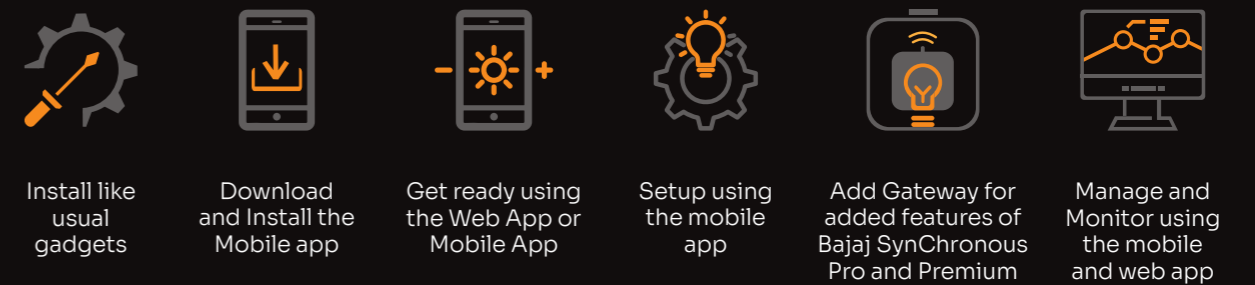

FEATURES AND BENEFITS



Motion Sensing
activates lights only when in use, saving energy.



Daylight Harvesting
automatically dims lights based on sunlight levels.



Wireless switches
enable easy lighting control from anywhere they're installed.



Remote Maintenance
Monitor device lifetimes, potential failures, and burning hours for improved building upkeep.



Energy Usage Analysis
Access detailed energy consumption reports for up to 12 months, exportable in .csv format for further analysis.



Automatic Upgrades
Seamlessly receive background updates for features and security with minimal disruption to building operations.



Scene Scheduler
create and recall custom scenes effortlessly using wireless switches or an app.



Organise your lights
by grouping them into networks and further subdividing into groups and zones for precise control.



App Control
Customize nearby lights according to user preferences.



Light Scheduler
Schedule scenes to suit your needs.



Remote Light Control
Remote control all lights using the web app.



HIGHBAY LIGHTING

Creates an ideal and safe workspace with high level of accuracy and performance.

Right Illumination of Production bay is critical for productivity. Hence, well-designed and energy-efficient lighting plays an important role in ensuring uniform illumination so that operations take place safely and smoothly.

NOVABAY

Blend of beauty and performance

Bajaj Novabay- The most energy efficient highbay lighting system, specially designed to deliver high lumens blended with aesthetic design of the luminaire



160
lm/W



Superior & appealing aesthetics

Pressure die-cast aluminum housing with Aesthetically designed LED layout



Best in Class System Efficacy

160lm/w, ensures highest energy saving with quicker payback



Uniform Distribution

Round Form Factor Luminaire



High Performance Driver

Constant current driver is provided with built in surge protection, open & short circuit protection, IP67 protection & EMI/EMC compliance



IP66
Ingress Protection



4kV
Internal Surge Protection -
10kV External SPD



THD<10%
PF>0.95

SYNCHRONUS
ENABLED



Heat sink designed to ensure better heat dissipation



Applications



Product Diagram

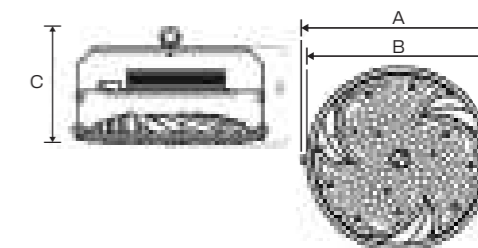

Dimension in mm

Electrical Parameters

Correlated Color Temperature	5700K
Color Rendering Index	>70
Maintenance of Lumen Output	50,000 hrs.
Operating Temperature	-10°C to 50°C
Input Voltage Range	140 to 270 V AC

Specifications & Dimensions

Wattages	Product Description	Voltage	Lumen	System Current (Amp.)	Dimensions		
					A	B	C
80W	Novabay 80W WH NB PC SD XE	240	12800	0.35A	236	221	141
100W	Novabay 100W WH NB PC SD XE	240	16000	0.43A	236	221	141
120W	Novabay 120W WH NB PC SD XE	240	19200	0.52A	296	280	153
150W	Novabay 150W WH NB PC SD XE	240	24000	0.65A	296	280	153
200W	Novabay 200W WH NB PC SD XE	240	32000	0.87A	344	325	171

Also available with 130lm/W option.
NB = 60° beam angle

NUKE

Robust product designed to work in harsh weather conditions

Nuke highbay is with high grade aluminium die-cast heat sink that guarantees commendable thermal management. Furthermore, it is prewired with accessories up to the terminal block and eyebolt for hassle-free installation.



- 

Superior & appealing aesthetics
High resistance toughened glass to cater to high temperature harsh environments
- 

Best in Class System Efficacy
130lm/w, ensures highest energy saving
- 

Narrow & Wide Beam Optics
For more flexibility that caters to various applications & mounting height requirements
- 

High Performance Driver
Separate driver box for better thermal management

- 

IP66
Ingress Protection
- 

4KV
Internal Surge Protection -
10kV External SPD
- 

THD<10%
PF>0.95

SYNCHRONOUS
ENABLED



Applications



Product Diagram

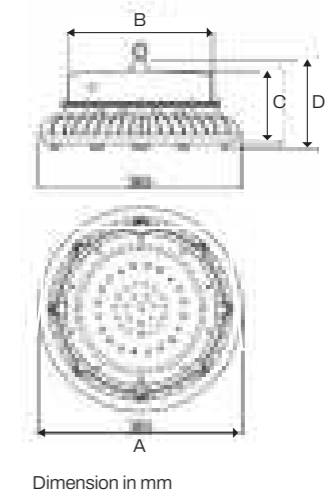

Electrical Parameters

Correlated Color Temperature	5700K
Color Rendering Index	>70
Maintenance of Lumen Output	50,000 hrs.
Operating Temperature	-10°C to +50°C
Input Voltage Range	140 to 270 V AC

Specifications & Dimensions

Wattages	Product Description	Voltage	Lumen	System Current (Amp.)	Dimensions			
					A	B	C	D
100W	BIHNK 100W WH NB TG SD	240	13000	0.43A	245	180	145	182
120W	BIHNK 120W WH NB TG SD	240	15600	0.52A	280	260	130	155
150W	BIHNK 150W WH NB TG SD	240	19500	0.65A	300	260	130	155
200W	BIHNK 200W WH NB TG SD	240	26000	0.87A	305	290	130	155
240W	BIHNK 240W WH NB TG SD	240	31200	1.05A	305	290	130	155

PC lens diffuser version with 150 lm/W efficacy is available
NB = 60° beam angle, WB = 90° beam angle optional

OPTIBAY

For Optimum Lighting Solutions for Industrial Bays

Optibay is a new range of highbay lighting solution that gives optimum life cycle cost—combining superior illumination experience with optimised total system investment to our Industrial Customers



Superior & appealing aesthetics
Epoxy powder coated pressure die-cast aluminium PDC housing with modular lens



Best in Class System Efficacy
≥120 lumens per watt



Uniform Distribution
Round Form Factor Luminaire



High Performance Driver
Dedicated driver box housing containing Potted CC Driver for better thermal isolation



IP66
Ingress Protection



4KV
Internal Surge Protection and 10kv external SPD



THD<10%
PF>0.95

SYNCHRONOUS
ENABLED



Applications



Warehouse



Industry



Factory

Product Diagram

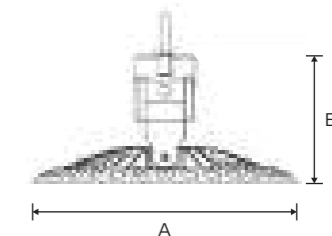
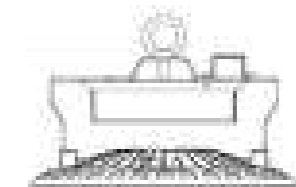

Dimension in mm

Electrical Parameters

Correlated Color Temperature	5700K
Color Rendering Index	>70
Maintenance of Lumen Output	50,000 hrs.
Operating Temperature	0°C to 50°C
Input Voltage Range	140 to 270 V AC

Specifications & Dimensions

Wattages	Product Description	Voltage	Lumen	System Current (Amp.)	Dimensions	
					A	B
80W	Optibay 80W WH NB PC SD	240	9600	0.38A	270	130
100W	Optibay 100W WH NB PC SD	240	12000	0.48A	270	130
120W	Optibay 120W WH NB PC SD	240	14400	0.57A	270	130
150W	Optibay 150W WH NB PC SD	240	18000	0.72A	303	130

* CRI>80 version available for special applications
NB = 60° beam angle, WB = 90° beam angle optional

BLAZE LINEAR

Designed to Illuminate Large Spaces

Linear Highbay is designed for lighting of special application areas like warehouses, and passageways.



Slick & Thermally Efficient Design

For longer life and reliable operations with matt grey powder coated aluminium extruded housing



Best in Class System Efficacy

130lm/w, ensures highest energy saving



Ideal for horizontal lighting spread

LEDs are provided with lens optics to get optimum optical performance

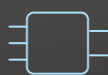

High Performance Driver

Specially designed to have built-in surge voltage, open/short circuit protections

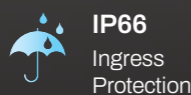

IP66
Ingress Protection



4KV
Internal Surge Protection



THD < 10%
PF > 0.95

SYNCHRONOUS
ENABLED

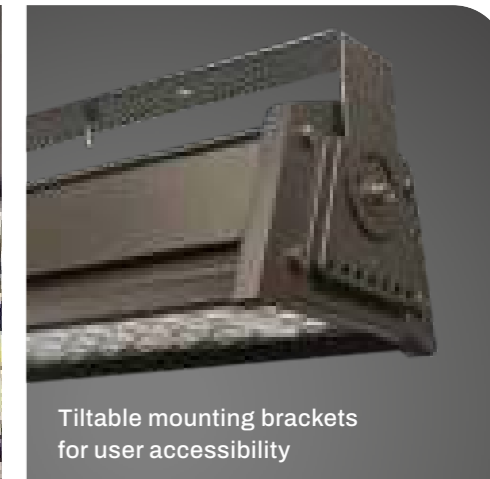

Tiltable mounting brackets for user accessibility



Compact design ensure lesser dust accumulation and ease of maintenance.

Applications



Warehouse



Industry



Factory

Product Diagram

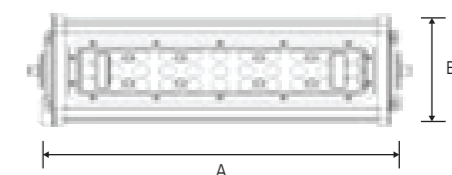

Dimension in mm

Electrical Parameters

Correlated Color Temperature	5700K
Color Rendering Index	>70
Maintenance of Lumen Output	50,000 hrs.
Operating Temperature	-10°C to +50°C
Input Voltage Range	140 to 270 V AC

Specifications & Dimensions

Wattages	Product Description	Voltage	Lumen	System Current (Amp.)	Dimensions	
					A	B
60W	BGHBM .nxt BL 78L WH SY SD	240	7800	0.26A	358	150
80W	BGHBM .nxt BL 104L WH SY SD	240	10400	0.35A	358	150
100W	BGHBM .nxt BL 130L WH SY SD	240	13000	0.42A	358	150
120W	BGHBM .nxt BL 156 L WH SY SD	240	15600	0.52A	358	150
150W	BGHBM .nxt BL 195L WH SY SD	240	19500	0.65A	688	150



INDUSTRIAL WELLGLASS

LED Industrial Well Glass Luminaires, where precision meets durability. Designed for optimal performance in industrial settings, these luminaires illuminate workspaces with unparalleled efficiency. Discover the perfect synergy of innovation and rugged design with our LED Industrial Well Glass Luminaires.

VERDANT

LED Wellglass Designed to work in industrial environments

Dicast AL housing LED wellglass luminaires with PC clear/opal diffuser. Equipped with 4 kV in-built surge protection, IP66 Protection rating. Eye bolt and cradle is provided for mounting.



- 

Slick & Thermally Efficient Design
For longer life and reliable operations with matt grey powder coated pressure die-cast aluminum housing
- 

Best in Class System Efficacy
100lm/W, ensures highest energy saving
- 

Uniform Distribution of light
- 

Built-in High Performance Driver
Potted Driver used for long life and thermal performance

- 

IP66
Ingress Protection
- 

4KV
Internal Surge Protection -
10kV External SPD optional
- 

THD<10%
PF>0.95



Applications

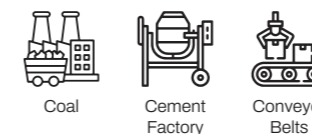

Product Diagram

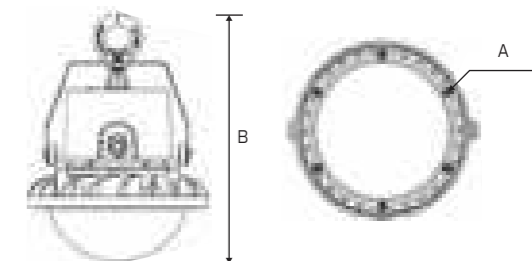

Dimension in mm

Electrical Parameters

Correlated Color Temperature	5700K
Color Rendering Index	>70
Maintenance of Lumen Output	50,000 hrs.
Operating Temperature	0°C to +50°C
Input Voltage Range	140 to 270 V AC

Specifications & Dimensions

Wattages	Product Description	Voltage	Lumen	System Current (Amp.)	Dimensions	
					A	B
30W	BIWDN 30W LED WH EC OD P	240	3000	0.14A	Ø135	188
35W	BIWDN 35W LED WH EC OD P	240	3500	0.16A	Ø135	188
40W	BIWDN 40W LED WH EC OD P	240	4000	0.19A	Ø135	188
45W	BIWDN 45L LED WH EC CDP	240	4500	0.20A	Ø135	188

Also available with clear diffuser

VERDANT PRO

LED Wellglass Designed to work in industrial environments

Dicast AL housing LED wellglass luminaires with PC opal diffuser. Equipped with 4 kV in-built surge protection, IP66 Protection rating. Eye bolt and cradle is provided for mounting.



- 

Slick & Thermally Efficient Design
For longer life and reliable operations with matt grey powder coated pressure die-cast aluminum housing
- 

Best in Class System Efficacy
100lm/W, ensures highest energy saving
- 

Uniform Distribution of light
- 

Built-in High Performance Driver
Potted Driver used for long life and thermal performance

 **IP66**
Ingress Protection

 **4kV**
Internal Surge Protection -
10kV External SPD optional

 **THD<10%**
PF>0.95



Cradle is given for ease of mounting



Compact design ensure lesser dust accumulation and ease of maintenance.

Applications

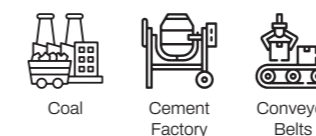

Product Diagram

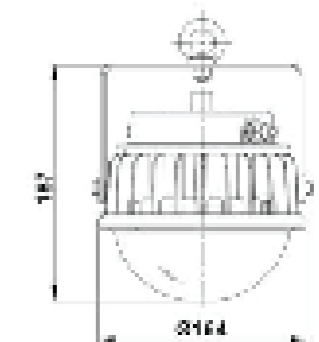

Dimension in mm

Electrical Parameters

Correlated Color Temperature	5700K
Color Rendering Index	>70
Maintenance of Lumen Output	50,000 hrs.
Operating Temperature	0°C to +50°C
Input Voltage Range	140 to 270 V AC

Specifications & Dimensions

Wattages	Product Description	Voltage	Lumen	System Current (Amp.)	Dimensions	
					A	B
65W	BIWDN 65L LED WH P	240	6500	0.30A	Ø164	187
70W	BIWDN 70W LED WH EC OD	240	7000	0.30A	Ø164	187

Also available with clear diffuser



INDUSTRIAL BATTENS

Cost-Effective Lighting
for Industrial Spaces

Durable and versatile, industrial LED batten lights are ideal for warehouses and factories. They offer powerful indoor and outdoor illumination, all while being cost-effective with low energy consumption.

LINEA

Surface/Pendent mounted Industrial Batten

Brightness well defined

Aluminium extrusion Housing LED batten luminaire with 120 lm/W efficacy. Suitable for surface/ suspended mounting applications.



Superior & Apealing Aesthetics

White powder coated extruded aluminium housing with polycarbonate diffuser



Best in Class System Efficacy

120lm/w, ensures highest energy saving



Uniform Distribution

Opal diffuser is supported by a pair of engineering plastic end caps.



High Performance Driver

Luminaire is provided with constant current LED driver with Open/Short circuit protection



IP20
Ingress Protection



4KV
Internal Surge Protection



THD<10%
PF>0.95



Engineering plastic end caps which facilitate easy removal for maintenance.



Applications



Product Diagram

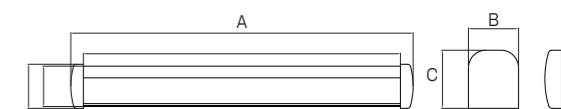

Dimension in mm

Electrical Parameters

Correlated Color Temperature	5700K
Color Rendering Index	>80
Maintenance of Lumen Output	50,000 hrs.
Operating Temperature	0°C to +45°C
Input Voltage Range	140 to 270 V AC

Specifications & Dimensions

Wattages	Product Description	Voltage	Lumen	System Current (Amp.)	Dimensions		
					A	B	C
20W	BLIR 24L WH PC SD	240	2400	0.09A	1220	40	47
40W	BLIR 48L WH PC SD	240	4800	0.19A	1220	40	47

LINEA PLUS

Industrial Weatherproof Batten
IP65 protection

Light that shines in every weather
Industrial LED batten which is waterproof & corrosion resistant for all industrial applications.



Superior & Apealing Aesthetics
White co-extruded PC housing with extruded aluminum base

Best in Class System Efficacy
120lm/w, ensures highest energy saving

Uniform Distribution
Opal diffuser is supported by a pair of engineering plastic end caps.

High Performance Driver
Luminaire is provided with constant current LED driver with Open/Short circuit protection

IP65
Ingress Protection

4KV
Internal Surge Protection

THD<10%
PF>0.95



Mounting clips for surface/suspension mounting.

Applications

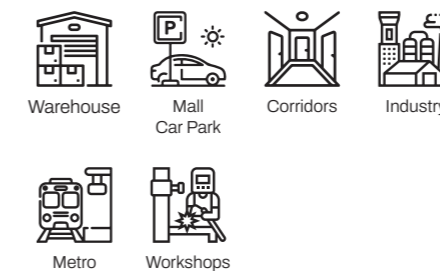

Product Diagram

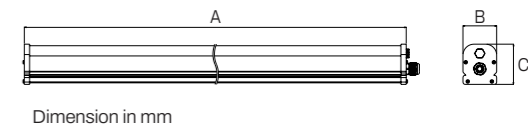

Electrical Parameters

Correlated Color Temperature	6500K
Color Rendering Index	>80
Maintenance of Lumen Output	50,000 hrs.
Operating Temperature	0°C to +45°C
Input Voltage Range	140 to 270V AC

Specifications & Dimensions

Wattages	Product Description	Voltage	Lumen	System Current (Amp.)	Dimensions		
					A	B	C
20W	BEPC 20W CW LED XE	240	2400	0.096A	600	54.5	65
40W	BEPC 40W CW LED XE	240	4800	0.19A	1200	54.5	65

LINEA BB

Industrial Weatherproof batten with emergency battery back-up

Polycarbonate housing with IP65 protection & Built-in emergency battery backup.



Superior & Apealing Aesthetics

Corrosion proof Polycarbonate housing suitable for surface and suspension mounting



Best in Class System Efficacy

120lm/w, ensures highest energy saving



Power Back-up

Up to 2 hrs. (20% of rated lumen) at full charge battery full charging time up to 8-10 hours



High Performance Driver

Constant current output driver with built-in surge protection

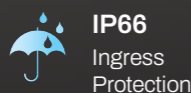

IP66
Ingress Protection



3KV
Internal Surge Protection



THD<10%
PF>0.90



Universal mounting
(surface plus suspended)



Slim Profile -
Ease of maintenance

Applications



Warehouse



Industry



Factory

Product Diagram

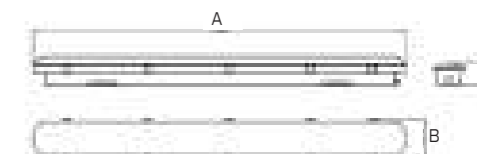

Dimension in mm

Emergency Mode

- System wattage during battery charging up to 41.5W
- Battery type Li-FePo4
- Battery capacity 14.8V, 2Ah.
- Indicator - Red LED ON during battery charging mode
- Auto stop of battery charging on full charge

Electrical Parameters

Correlated Color Temperature	5700K
Color Rendering Index	>80
Maintenance of Lumen Output	50,000 hrs.
Operating Temperature	0°C to +50°C
Input Voltage Range	140 to 270V AC

Specifications & Dimensions

Wattages	Product Description	Voltage	Lumen	System Current (Amp.)	Dimensions		
					A	B	C
36W	BIPC 40L LED XE WH WBB	270	4000	0.16A	1205	110.5	90

LUXBLADE

Industrial Weatherproof Batten

Light that shines in every weather

Industrial LED batten which is waterproof & corrosion resistant for all industrial applications.

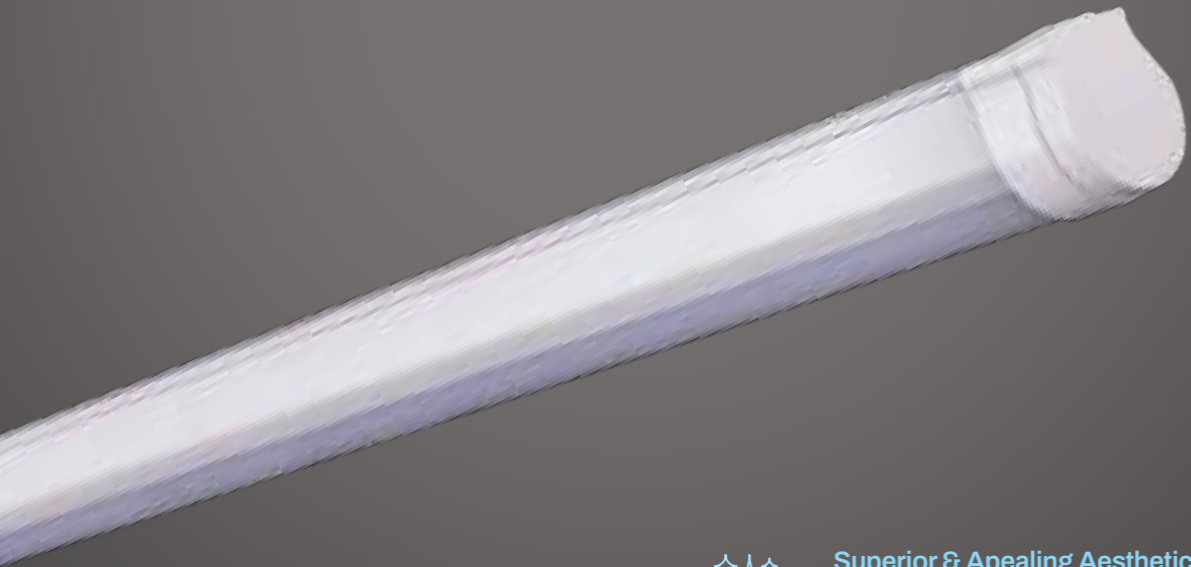

Superior & Apealing Aesthetics

White powder coated extruded aluminium
PC housing



Best in Class System Efficacy

110lm/w, ensures highest energy saving



Uniform Distribution

Opal diffuser for uniform light distribution

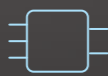

High Performance Driver

Luminaire is provided with Built-in constant current LED driver with Open/Short circuit protection

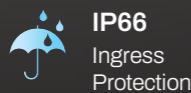

IP66
Ingress Protection



4KV
Internal Surge Protection



THD<10%
PF>0.95



Slim Profile

Applications



Warehouse



Mall
Car Park



Corridors



Industry

Product Diagram

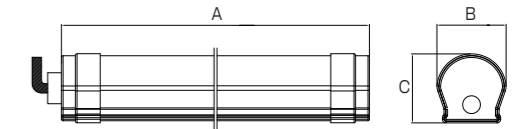

Dimension in mm

Electrical Parameters

Correlated Color Temperature	5700K
Color Rendering Index	>80
Maintenance of Lumen Output	50,000 hrs.
Operating Temperature	0°C to +45°C
Input Voltage Range	180 to 270V AC

Specifications & Dimensions

Wattages	Product Description	Voltage	Lumen	System Current (Amp.)	Dimensions		
					A	B	C
36W	BIBLB 40L WH PC SD	240	4000	0.18A	1200	45	45

WEE

Industrial Bulkhead

A robust but aesthetically designed bulkhead
WEE bulkhead is an energy efficient, robust & maintenance-free luminaire.



Superior & Appealing Aesthetics

Combination of die-cast aluminum housing with polycarbonate diffuser gives robust design



Environment friendly

Contains no mercury or lead



Uniform Distribution

Polycarbonate opal diffuser for durable long life

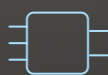

High Performance Driver

Constant current output driver with built-in surge protection

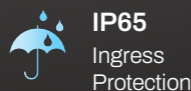

IP65
Ingress Protection



2.5KV
Internal Surge Protection



THD < 10%
PF > 0.90



Applications



Outdoor Area



Basement



Staircase



Parking Areas



Industrial Kitchen

Product Diagram

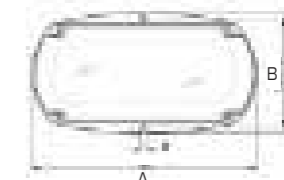

Dimension in mm

Electrical Parameters

Correlated Color Temperature	5700K
Color Rendering Index	>80
Maintenance of Lumen Output	50,000 hrs.
Operating Temperature	-10°C to +45°C
Input Voltage Range	180 to 270V AC

Specifications & Dimensions

Wattages	Product Description	Voltage	Lumen	System Current (Amp.)	Dimensions		
					A	B	C
10W	BIBWP 10W LED	240	1000	0.044A	182	103	112



LED CANOPY LUMINAIRE

Elevate your customers experience with our state of art canopy lighting solutions. Designed to captivate motorist, our lights create a welcoming atmosphere, guiding them to safety. Brighten up your station with vibrant illumination, ensuring a sense of security for every visitor. Our canopy lights not only enhance visibility but also elevate the aesthetics of your petrol station. Drive in with confidence, knowing you're under the radiance of safety and comfort.

LUCID

LED Canopy Luminaire

Highly energy efficient and exceptionally tough Canopy Luminaire Bajaj Lucid Canopy Luminaire is equipped with powder coated pressure die-cast aluminium housing. It has a heat resistance clear toughened glass and silicon gasket fixed with SS screws to maximise durability and safety.

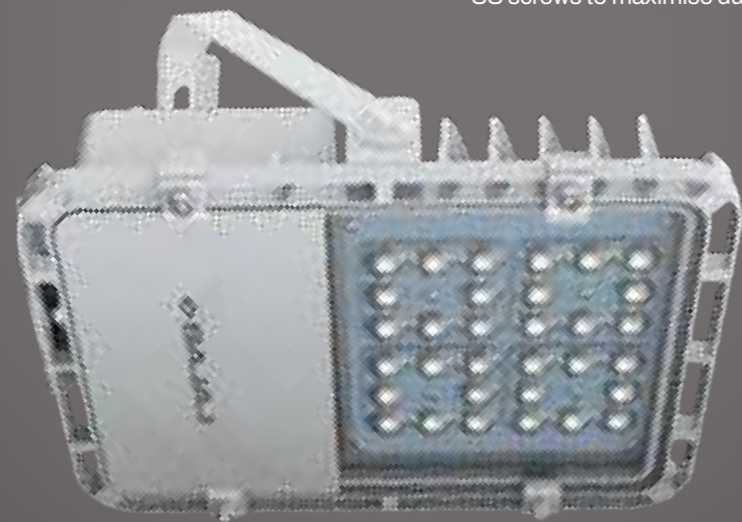

Superior & appealing aesthetics
Powder coated pressure die-cast aluminium housing with a heat resistance clear toughened glass



Best in Class System Efficacy
with upto 120 lumens per watt



Highest Mounting Flexibility
Full cradle is attached and alternative of eyebolt is also provided to give highest mounting flexibility to end users



High Performance Driver
Dedicated driver box housing containing Potted CC Driver for better thermal isolation

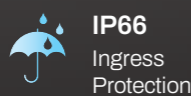

IP66
Ingress Protection



4KV
Internal Surge Protection



THD<10%
PF>0.95

SYNCHRONOUS
ENABLED



Curve shaped luminaire to increase aesthetics and improve cut-out design



Only 4 screws –
For ease of maintenance

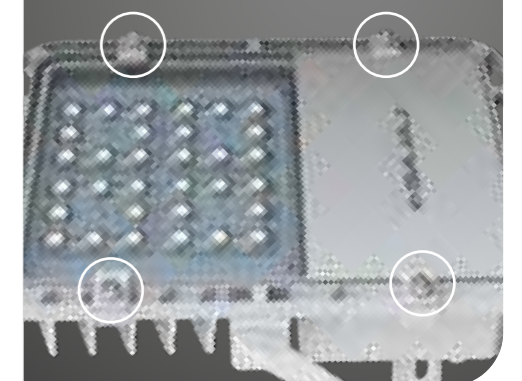

Applications



Toll



Gas RO



Factory

Electrical Parameters

Correlated Color Temperature	5700K
Color Rendering Index	>70
Maintenance of Lumen Output	50,000 hrs.
Operating Temperature	0°C to +50°C
Input Voltage Range	140 to 280 V AC

Product Diagram

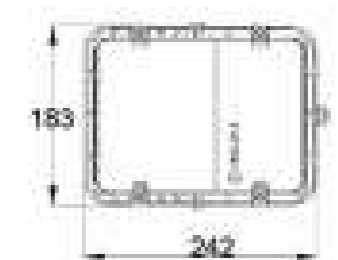

Dimension in mm

Specifications & Dimensions

Wattages	Product Description	Voltage	Lumen	System Current (Amp.)	Dimensions		
					A	B	C
80W	BICLD 80W WH TG SD	240	9600	0.34A	183	242	98
100W	BICLD 100W WH TG SD	240	12000	0.42A	183	242	98

* Available 450x450mm CRCA frame for recess mounting

LUCID-LINEAR

LED Canopy Luminaire

This Linear Canopy Luminaire is equipped with extruded aluminium housing, aluminium die-cast end caps, and PC diffuser for extraordinary optical performance. The product is characterised with an external surge protection to ensure maximum safety at petrol stations.



Superior & appealing aesthetics

Extruded aluminium housing for better thermal management designed to maximize optical performance



Best in Class System Efficacy

Upto 100 lumens per watt efficacy



Uniform Distribution

Polycarbonate diffuser for extraordinary optical performance



High Performance Driver

A non-integrated driver that guarantees easy maintenance



IP65
Ingress Protection



4kV
Internal Surge Protection -
10kV External SPD



THD<10%
PF>0.95

SYNCHRONOUS
ENABLED



Specially designed extrusion housing to maximize optical performance



IP 67 Non integral driver for ease of maintenance

Applications



Petrol Pumps

Product Diagram

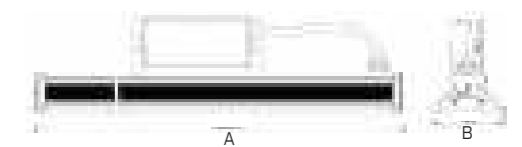

Dimension in mm

Electrical Parameters

Correlated Color Temperature	5700K
Color Rendering Index	>80
Maintenance of Lumen Output	50,000 hrs.
Operating Temperature	-10°C to 50°C
Input Voltage Range	140 to 270 V AC

Specifications & Dimensions

Wattages	Product Description	Voltage	Lumen	System Current (Amp.)	Dimensions	
					A	B
40W	BGPPR LC 40L LED 4F WH SY NID	240	4000	0.17A	1200	70
80W	BGPPR LC 80L LED 8F WH SY NID	240	8000	0.35A	2400	70

*20W option also available on request



CLEANROOM LUMINAIRES

Lighting system designed for controlled environments

Manufacturing workspaces in the pharmaceutical industry, food processing plants, and electronic components industry requires dust-free - controlled environments. This requires special lighting systems.

PRISTINE

Bottom Opening Range

Lighting system for controlled environment
Clean room luminaires are specifically designed to ensure that specifications of clean room environments, which require high levels of cleanliness and hygiene to prevent contamination of the products or processes being carried out within the space.



Superior & appealing aesthetics
CRCA powder coated housing with screwless bottom frame



Best in Class System Efficacy
with $\geq 120\text{lm/W}$



Uniform Distribution
Opal PMMA diffuser sealed in bottom frame with gasket



Ease of Maintenance
Access from bottom



IP65
Ingress Protection
(From bottom)



4KV
Internal Surge Protection



THD < 10%
PF > 0.95

SYNCHRONOUS
ENABLED



Applications



Laboratory / OT



Food Processing



Pharmaceuticals

Product Diagram



Dimension in mm

Electrical Parameters

Correlated Color Temperature	5700K
Color Rendering Index	>80
Maintenance of Lumen Output	50,000 hrs.
Operating Temperature	-10°C to 45°C
Input Voltage Range	140 to 270 V AC

Specifications & Dimensions

Wattages	Product Description	Voltage	Lumen	System Current (Amp.)	Cutout Size in mm
20W	BPRF 20W WH SL LED*	240	2000	0.09A	300 x 300
36W	BPRF 36W WH SL LED XE	240	4320	0.15A	565 x 565
45W	BPRF 45W WH SL LED XE	240	5400	0.19A	565 x 565
60W	BPRF 60W WH SL LED XE	240	7200	0.26A	565 x 565
80W	BPRF 80W WH SL LED XE	240	9600	0.35A	565 x 565

*20W Efficacy - 100lm/W

PRISTINE

Top Opening Range

Lighting system for controlled environment
Clean room luminaires are purposefully designed to ensure optimal performance within these controlled environments, where precision and reliability are paramount to sustaining the integrity of the space.



Superior & appealing aesthetics
CRCA powder coated housing with screwless bottom frame



Best in Class System Efficacy
with upto 120 lumens per watt



Uniform Distribution
Opal PMMA diffuser sealed in bottom frame with gasket



Ease of Maintenance
Access to the driver is from top.
Easy mounting in walkable false ceiling.



IP65
Ingress Protection
(From bottom)



4KV
Internal Surge Protection



THD<10%
PF>0.95

SYNCHRONOUS
ENABLED

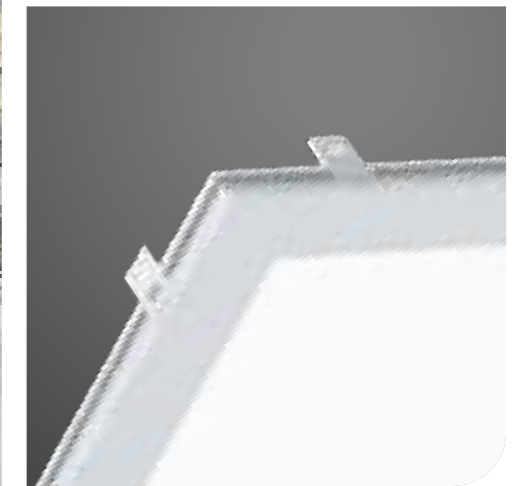

Applications

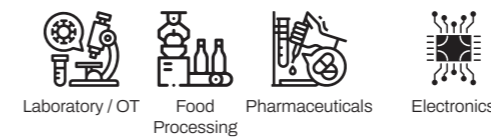

Product Diagram

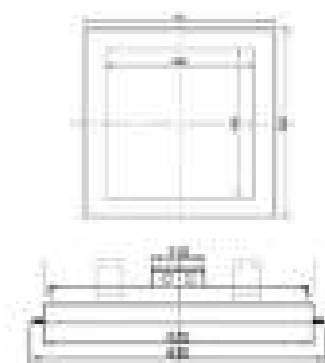

Dimension in mm

Electrical Parameters

Correlated Color Temperature	5700K
Color Rendering Index	>80
Maintenance of Lumen Output	50,000 hrs.
Operating Temperature	-10°C to 45°C
Input Voltage Range	140 to 270 V AC

Specifications & Dimensions

Wattages	Product Description	Voltage	Lumen	System Current (Amp.)	Cutout Size in mm
20W	BPRR 20W WH SL LED XE	240	2000	0.09A	330 x 330
30W	BPRR 30W WH LED XE	240	3000	0.14A	600 x 600
36W	BPRR 36W WH SL LED XE	240	4320	0.16A	600 x 600
45W	BPRR 45W WH LED XE	240	5400	0.22A	600 x 600
60W	BPRR 60W WH LED XE	240	7200	0.29A	600 x 600
80W	BPRR 80W WH LED XE	240	9600	0.35A	600 x 600

Walkable false ceiling cover supplied on request

PRISTINE

Surface Mounting

Lighting system for controlled environment
Clean room luminaires are meticulously crafted to meet the stringent requirements of clean room environments, where maintaining exceptionally high levels of cleanliness and hygiene is imperative to safeguard products or processes from contamination.

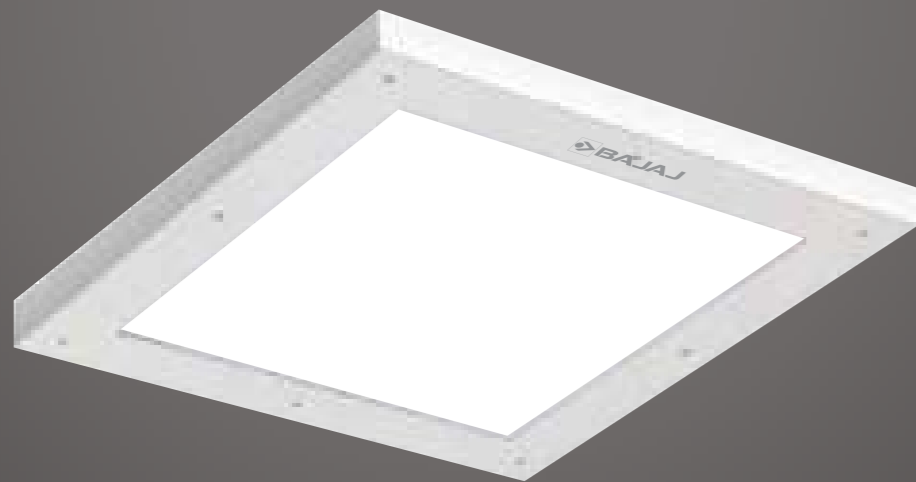

Superior & appealing aesthetics
CRCA powder coated housing suitable for surface mounting

Best in Class System Efficacy
with upto 100 lumens per watt

Uniform Distribution
Opal PMMA diffuser sealed in bottom frame with gasket

Ease of Maintenance

IP65
Ingress Protection
(From bottom)

4KV
Internal Surge Protection -
10kV External SPD

THD<10%
PF>0.95

SYNCHRONOUS
ENABLED



Applications



Product Diagram

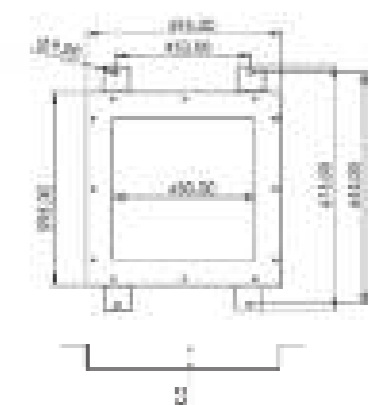

Dimension in mm

Electrical Parameters

Correlated Color Temperature	5700K
Color Rendering Index	>70
Maintenance of Lumen Output	50,000 hrs.
Operating Temperature	-10°C to 50°C
Input Voltage Range	140 to 280 V AC

Specifications & Dimensions

Wattages	Product Description	Voltage	Lumen	System Current (Amp.)	Dimensions					
					A	B	C	D	E	F
36W	BPSF 36W WH LED	240	3600	0.17A	595	450	452	675	655	82
45W	BPSF 45W WH LED	240	4500	0.22A	595	450	452	675	655	82



METRO LIGHTING

Ensuring a balance between functionality and aesthetics, metro station lighting plays a pivotal role in creating a safe and welcoming environment for commuters. From well-lit platforms to accentuating architectural features with strategic lighting design, every aspect is meticulously planned. Energy efficiency is a priority, with LED fixtures and motion sensors contributing to sustainability. Accessibility is key, with uniform lighting levels aiding passengers of all abilities. Safety measures include adequate CCTV lighting and prominently lit emergency call boxes.

METROLITE

Trunk mounted Linear industrial batten –
Specially designed for Metro and Railway projects



Superior & appealing aesthetics

Extruded Aluminium Housing with Polycarbonate Opal diffuser. Luminaire is mounted on trunk made of extruded aluminium with end caps of engineering plastic



Best in Class System Efficacy

140lm/w, ensures highest energy saving



Uniform Distribution

Polycarbonate Opal diffuser for uniform light distribution



High Performance Driver

Constant current integral LED driver is provided, having open/short circuit protection and built-in surge protection

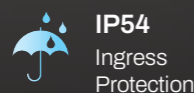

IP54

Ingress Protection



3KV

Internal Surge Protection



THD<10%

PF>0.95

SYNCHRONOUS
ENABLED



Applications



Metro Station



Corridors

Product Diagram

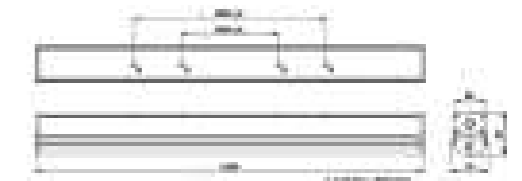

Dimension in mm

Electrical Parameters

Correlated Color Temperature	5700K
Color Rendering Index	>80
Maintenance of Lumen Output	50,000 hrs.
Operating Temperature	0°C to +40°C
Input Voltage Range	150 to 270 V AC

Specifications & Dimensions

Wattages	Product Description	Voltage	Lumen	System Current (Amp.)	Dimensions		
					A	B	C
28W	BLTMO T 40L LED WH SY PC SD	240	4000	0.12A	1209	65	87
45W	BLTMO T 58L LED WH SY PC SD	240	5850	0.22A	1209	65	87



INDUSTRIAL FLAMEPROOF

Luminaires Designed for
Hazardous Environment.

In environments where the combination of flammable gases and ignition sources can lead to dangerous conditions, standard lighting solutions fall short. Hazardous area lighting solutions are specifically engineered to meet the unique requirements of these high-risk environments.

FLAMEPROOF WELLGLASS

Wellglass suitable for Hazardous Area application in Gas group IIC environments. Approved by CIMFR and PESO.



Superior & appealing aesthetics
Powder coated aluminium die-cast housing



Loop in Loop out enabled with M20 Gland
For ease of installation & maintenance



High Performance Driver
Constant current integral LED Driver is provided, having open/short circuit protection and Built-in surge protection

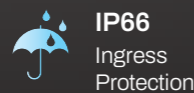

IP66
Ingress Protection



4kV
Internal Surge Protection -
10kV External SPD



THD<10%
PF>0.95



Applications



Coal



Cement
Factory



Refineries



Petrochemical
Industry

Product Diagram

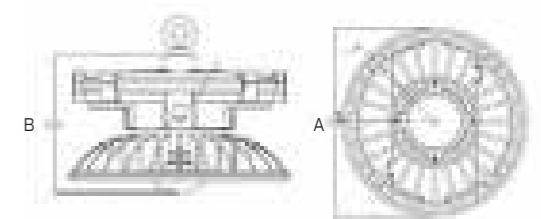

Dimension in mm

Electrical Parameters

Correlated Color Temperature	5700K
Color Rendering Index	>70
Maintenance of Lumen Output	50,000 hrs.
Operating Temperature	-10°C to +40°C
Input Voltage Range	140 to 270 V AC

(Suitable for Zone 1 & 2 and Gas group 2C. CIMFR Certificate no. - IN/CIMFR/TR23/P/2884)

Specifications & Dimensions

Wattages	Product Description	Voltage	Lumen	System Current (Amp.)	Dimensions	
					A	B
30W	BIFPWG 30W CLED SD	240	3000	0.15A	Ø260	150
45W	BIFPWG 45W CLED SD	240	4500	0.21A	Ø260	150
70W	BIFPWG 70W CLED SD	240	7000	0.36A	Ø260	150

FLAMEPROOF HIGHBAY

Highbay luminaires suitable for Hazardous Area application in Gas group IIC environments. Approved by CIMFR and PESO.



Superior & appealing aesthetics
Powder coated aluminium die-cast housing



Loop in Loop out enabled with M20 Gland
For ease of installation & maintenance



High Performance Driver
Constant current integral LED Driver is provided, having open/short circuit protection and Built-in surge protection

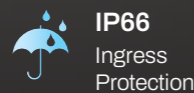

IP66
Ingress Protection



4KV
Internal Surge Protection -
10kV External SPD



THD<10%
PF>0.95



Applications

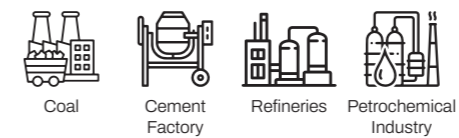

Product Diagram

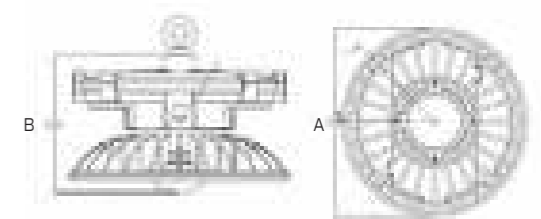

Dimension in mm

Electrical Parameters

Correlated Color Temperature	5700K
Color Rendering Index	>70
Maintenance of Lumen Output	50,000 hrs.
Operating Temperature	-10°C to +40°C
Input Voltage Range	140 to 270 V AC

(Suitable for Zone 1 & 2 and Gas group 2C. CIMFR Certi No. - IN/CIMFR/TR23/P/3688)

Specifications & Dimensions

Wattages	Product Description	Voltage	Lumen	System Current (Amp.)	Dimensions	
					A	B
100W	BIFPWG 100W CLED SD	240	10000	0.48A	Ø260	150
120W	BIFPWG 120W CLED SD	240	12000	0.57A	Ø260	150

FLAMEPROOF LINEAR LUMINAIRE

Flameproof/weatherproof luminaire suitable for LED tube light fitting. Suitable for 2x18W LED lamp



IP60
Ingress
Protection

Applications



Coal Cement Factory Refineries Petrochemical Industry

Electrical Parameters

- Housing MATERIAL: Cast Aluminium LM 6
- GLASS: Heat-resistant tubular glass
- CABLE ENTRY: 2-way M20 x 1.5 pitch
- GASKET: Neoprene.
- Type of protection Ex 'd' GROUPS: II B Atmosphere only. ZONE – 1 & 2 CIMFR. CERT. No. : CIMFR/TC/P/934 Dated – 22nd Sept.,2014 (Cat. No. BJEXFTL 2x36) KARANDIKAR LAB TEST REPORT NO: KLPL/BTG/17/01-68 Did.-23/02/2017 (Suitable for 1/2 x 18W TUBE LIGHT) TEMP. CLASS: 1/2x18W LED – T6

Specifications & Dimensions

Wattages	Product Description	Suitable for	Dimensions		
			A	B	C
18W	BJEXFTL 118W LED	1 x 18 W LED Tube	1485	125	165
36W	BJEXFTL 218W LED	2 x 18 W LED Tube	1485	268	165

Product Diagram

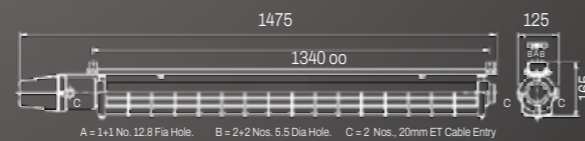

Dimension in mm





Electricals

27th Floor, One Unity Center (Erstwhile One International Center, Tower 4),
Senapati Bapat Marg, Prabhadevi (West), Mumbai – 400013 | Tel.: 022-2406 4400
E-mail: illumination@bajajelectricals.com | www.bajajelectricals.com

[f /BajajElecBiz](#) [X /BajajElecBiz](#) [i /bajajelecbiz](#) [in /BajajElectricals](#)

Images of the products shown are for representation purpose only
and the actual colour/size may vary.