

CATALOG



CABLOFIL® Cable Management

PW® Ladder Tray

TROUGH TRAYS Fiber Trough & V-Trough

FASTENERS J-Hooks, FAS Power® Brackets & CabloPort

2016
2017

designed to be better.™

 **legrand®**

LEGRAND

Table of contents



CONTENTS

- INTRODUCTION
PAGES A.1–A.9
- WIRE CABLE TRAY
PAGES A.10–A.19
- SPLICING
PAGES A.20–A.27
- WALL MOUNTINGS
PAGES A.28–A.37
- CEILING MOUNTINGS
PAGES A.38–A.47
- UNDERFLOOR
PAGES A.48–A.59
- FIBER OPTIC
PAGES A.60–A.65
- OTHER MOUNTINGS
PAGES A.66–A.79
- ACCESSORIES
PAGES A.80–A.81
- INSTALLATIONS
PAGES A.86–A.105

- INTRODUCTION
PAGES B.1–B.7
- LADDER TRAY, TROUGH
& SOLID BOTTOM
PAGES B.8–B.79
 - ITRAY PAGES B.10–B.25
 - METALLIC PAGES B.26–B.69
 - FIBERGLASS PAGES B.70–B.79
- CHANNEL SYSTEMS
PAGES B.80–B.89
- CABLE RUNWAY
PAGES B.90–B.95





Trough Tray

C



Legrand® Fasteners

D

- INTRODUCTION
PAGES C.1-C.5
- TRAY, SPLICES & FITTINGS
PAGES C.6-C.15
- SUPPORTS & ACCESSORIES
PAGES C.18-C.25
- INSTALLATIONS
PAGES C.26-C.29
- SPECIFICATIONS
PAGES C.30-C.31
- CROSS REFERENCE
PAGES C.32-C.33

- INTRODUCTION
PAGES D.1
- J-HOOKS
PAGES D.2-D.8
- OTHER FASTENERS
PAGES D.9-D.11
- FAS POWER
PAGES D.12-D.23
- CABLOPORT
PAGES D.24-D.31
- SEISMIC BRACING
PAGES D.32-D.38

- FULL LINE PRODUCT INDEX
PAGES I.2-I.3



LEGRAND

The most **complete** line of

CABLOFIL®

Wire Mesh Cable Management



Cablofil Cable Management is the best choice data and power cable pathways in commercial and industrial projects. It can be installed quickly using smaller crews to reduce overall installed costs by up to 50%. Cablofil is constructed of precision engineered, high quality, welded steel wire and can be adapted to fit any installation on-site. A variety of offered finishes means Cablofil can be used for exposed indoor applications or in the most demanding exterior environments.

PW®

Ladder Tray



PW Ladder tray is the ultimate solution for heavy power cables in industrial applications. Ltray features a modified aluminum I-beam design that's suited for industrial installations with large diameter cables. The structural offset in the sidewall creates a strong, mid-span splice that reduces the number of supports required. PW Long Span Tray is available in aluminum and steel for extremely heavy loads and longer spans for roadway bridging. Our exclusive long span/heavy duty cable tray is designed with I-beam side rails that can span up to 50' and meet exacting industry and load standards.

cable management products

TROUGH TRAY

Fiber Trough & V-Trough



Cablofil Trough Tray is a cable management system designed to maximize network reliability and minimize lifecycle costs. Fiber Trough tray utilizes high strength steel components to provide the strength and durability required to manage fiber optic or copper cabling in the most demanding data center environments. V-Trough provides protection for power cables, keeping them cool and accessible. Cablofil Trough tray gives any installation a professional look and provides the ultimate protection for your cables.

FASTENERS

J-Hooks, FAS Power®, CabloPort & Seismic Bracing



Our new Fasteners line is comprised of the products that contractors use on a daily basis for cable management. J-Hooks, FAS Power pre-fab electrical products, CabloPort rooftop supports and cable tray support hardware. Each product is designed for easy installation and is constructed of quality materials that make for a lasting installation.

LEGRAND

The newest innovations

CABLOFIL

COTFIL50 / COTFIL100 Snap-In Wire Dividers



Snap-In Wire Dividers are the quick and easy way to

separate different cabling types within the same cable pathway. Available in 50mm and 100mm heights, each divider snaps in place without additional hardware or tools.

A.18

EZT90RS / RADT90RS Radius Shields

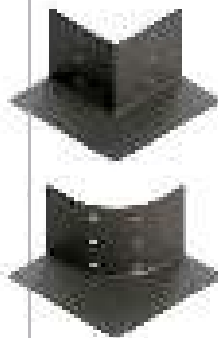

Radius shields create a smooth corner around junctions made with EZT90 and RADT90 hardware.

They're made from durable, black ABS plastic and include slots for mounting with zip ties.

A.61

CABLEXIT50 Cable Exit

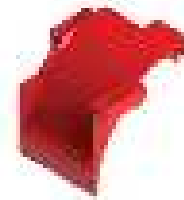

Use this cable exit for smaller groups of cables that are entering and exiting

Cablofil through the bottom of the tray. Its smooth, high-density plastic construction eliminates deformation and damage to cable bundles.

A.65

INSERTPP Plastic Inserts



Plastic inserts create a smooth bottom for sensitive

cable types in Cablofil cable management. Available in bottom only and bottom with sides, each 200' polypropylene roll can be easily cut to length to fit any installation.

A.63

HXB / RHXB / HTB Horizontal Cross Bridges



Junction bridges keep cables separated at tees and crosses in Cablofil cable management

for optimum network signal integrity. The unique design creates smooth cable transitions to keep cables from kinking and bunching.

A.62

TOH Fiber-Optic Twist-On Horn

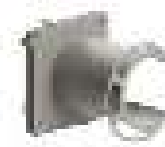

Fiber-Optic Twist-On Horn installs to any series Cablofil cable

management without tools or additional hardware. Use as a single or in multiple sets, on the bottom or sides of the tray to manage lengths of fiber optic cabling.

A.65

in cable management products

PW

TROUGH TRAY

OTDOFAS

Over-the-Top Drop Out



Use Over-the-Top Drop Out for cables that exit or enter on the side of the

tray and is designed to snap in place without additional hardware. Over-the-Top Drop Out features hold-down slots to secure cables in place.

A.64

IP34

Cable Tray Isolation Pad



Plastic pad reduces friction and vibration

in PW cable tray and support members. Also functions as an electrical isolation barrier between dissimilar metals. Red poly construction adds visibility and can be easily seen by inspectors. IP34 is plenum rated and UV resistant.

B.24

FTCHC

Center Hanger



Center Hanging Fiber Trough and V-Trough tray makes adding cables easy

with the new FTCHC. The open side allows greater access to cable pathways up to 12" wide and makes covers easier to remove and replace. Designed for medium duty loads.

C.17

OTDO

Over-the-Top Waterfall



Use Over-the-Top Waterfall for cables that exit or enter the side

of the tray. It eliminates the need to cut any side wires that reduce tray integrity. Over-the-Top Waterfall features steel, powder coated construction and hold-down slots to zip tie cables in place.

A.64

OHCB

Overhead Clamp Kit



OHCB clamps makes trapeze hanging PW ltray simple. OHCB keeps the integrity of the side rails intact without the need to drill

holes and keeps the supports well out of the cable pathway. Supports can be easily removed and reattached to add additional cables if needed.

B.24



LEGRAND

The newest additions to

FASTENERS

CJ Series

J-Hooks

Our CJ Series J-Hooks are engineered to provide stress-free for multiple cable bundles and features tapered edges to reduce cable sheath damage. They can also be ordered with ten attachment options for fast installation without the need for additional hardware. Available in four sizes from 3/4" to 4".



D.4

CJHP Series

Plastic Coated J-Hooks

Our "Cable Cage" plastic coated J-Hook features a built-in latch that allows you to lock the bendable flap into place. Available in sizes 1", 2" and 3" with two different attachment options.



D.6

CJ

Attachment Mounting Hardware

Use these attachment options for custom J-Hook combinations. Available in eight styles.



D.7

CJ4T

Bridle Rings

Bridle rings are a simple option for smaller cable bundles. Available in two sizes.



D.7

our fasteners product line

CWTB

Telescoping Box Bracket

Available in two sizes, this bracket fits standard or off-width studs without cutting. Use for box or cable support.



D.16

CWTSB

Telescoping Box Support

For heavier boxes, this bracket fits any stud spacing from 16" to 24". Plaster ring secures box in place. Fits 4-11/16" boxes.



D.16

F Series

Redesigned Floor Bracket

Our FAS Power Floor Bracket has been redesigned with a built-in wire clamp. Just remove from base, bend and slip it into place. Pre-drilled mounting holes make pre-fabricated wiring assemblies a snap.



D.14



CABLOFIL

TABLE OF CONTENTS

INTRODUCTION

PAGES A.1–A.9

WIRE CABLE TRAY

PAGES A.10–A.19

SPLICING

PAGES A.20–A.27

WALL MOUNTINGS

PAGES A.28–A.37

CEILING MOUNTINGS

PAGES A.38–A.47

UNDERFLOOR

PAGES A.48–A.59

FIBER OPTIC

PAGES A.60–A.65

OTHER MOUNTINGS

PAGES A.66–A.79

ACCESSORIES

PAGES A.80–A.81

INSTALLATIONS

PAGES A.86–A.105



CABLOFIL CABLE MANAGEMENT

The Industry Leader

CABLOFIL, THE FIRST NAME IN CABLE MANAGEMENT

Over 35 years ago, Cablofil was introduced to the European market. Since that time it has become the gold standard for cable management around the world. Its success is the result of on-going innovation and continued quality manufacturing practices that are being embraced by engineers and contractors alike. To date, more than 125,000 miles of Cablofil Cable Management have been installed globally.

COMMITMENT TO THE NORTH AMERICAN MARKET

Fifteen years ago, Cablofil was one of the first cable management manufacturers to market in the US, Mexico and Canada. Since then, demand for Cablofil has expanded rapidly requiring the establishment of a 78,000 sq. ft. manufacturing facility in Mascoutah, Illinois in 2001. This is currently the largest plant of its kind in North America. With this commitment, we have emerged as the US leader in product innovation, quality control and timely delivery.



THE INNOVATION CONTINUES

Legrand's vision and leadership has moved the cable management market forward with innovative ideas and product enhancements. And as the market changes, so do we. Each product within the Cablofil product line is constantly evaluated for improving cable pathway construction and to reduce installation times. We are constantly developing new products to embrace new cabling types and methods. Look to Legrand, the industry leader in cable management.



CABLOFIL CABLE MANAGEMENT

Web-based **Design Tools**

Cablofil Cable Management has always been easy to install, and with these online tools, it's now easy to design your next project. They will guide you through the Cablofil product line and help you plan your next project, quickly and easily. You can find links to all of these helpful programs at www.legrand.us/cablofil/tools.



Submittal Builder helps build submittals fast. Select the Cablofil parts that suit your project and Submittal Builder will assemble a cover sheet and all of the cut sheets needed for the materials you specified-in a single pdf file.



Use this online tool for a quick estimate of the Cablofil parts needed to complete your next project. Take Off Wizard will give you a material list by run, or a total bill of materials.



FAS Path Configurator helps you plan and create prefabricated cable management supports. Prefabricated or kitted supports are assembled by Legrand in advance and are shipped to the jobsite to reduce costs. Choose from three types of support systems – underfloor, wall or ceiling hung supports. Then configure your support online and print out a completed cut sheet.



Need a drawing or have a unique problem with your cable pathway design? This drawing library has a variety of product drawings and special application assemblies that are downloadable and ready to use.





interactive load table

Download this Excel spreadsheet to determine what size cable pathway you need for your application. It is loaded with sizes and weights for most standard data and power cable and will calculate volume and weight limits for your cable pathway.



FASpower configurator

FAS Power pre-wired assemblies from Legrand are now easier to order with an online configurator. Choose from floor or wall brackets and any number of accessories and our configurator will display an exploded drawing and a corresponding item number in seconds. A downloadable pdf cutsheet is instantly created that you can use in specification or ordering.



PW 3D drawing configurator

This a great tool to quickly select the proper tray by NEMA Class, size and material when planning your next project. Configure straight sections or horizontal and vertical fittings. A 2-D or 3-D drawing is created instantly in Solidworks, CATIA V5, AutoCAD 3D, IGES, STEP, or ParaSolid Binary formats and is available for download. Data sheets are available for all parts that you configure.



AutoCAD TOOLS

This add-on allows you to bring the power AutoCAD to your next Cablofil Cable Management project. Choose from multiple tray sizes and add them as an overlay to your plan. This add-on also allows you to generate a BOM for easy ordering.

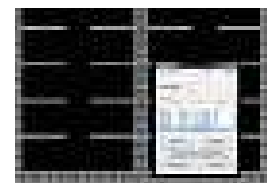

CABLOFIL CABLE MANAGEMENT

Engineered Solutions for Specific Applications

Cablofil is the right choice for cable management in all types of construction. Look to the leader for specially engineered products that reduce installation time and create cost-effective installations. For specific installation ideas and downloadable drawings, go to our online Best Practices web site at: www.legrand.us/cablofil/tools.

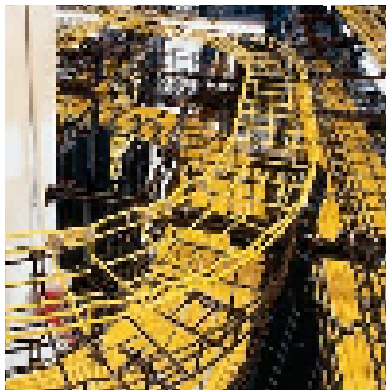

DATA CENTER

Cablofil Cable Management is especially suited for tight spaces usually associated with communication closet installations. All cable pathway turns, bends, and changes in elevation can be fabricated on-site with simple tools to speed installation time.

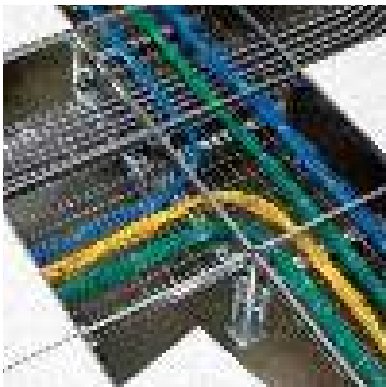

UNDERFLOOR

The UFS system was specifically designed for raised access floor cable management. UFS can be installed before or after floor installation with simple tools and is self-supporting, so it won't void the manufacturer warranty of raised access floors.

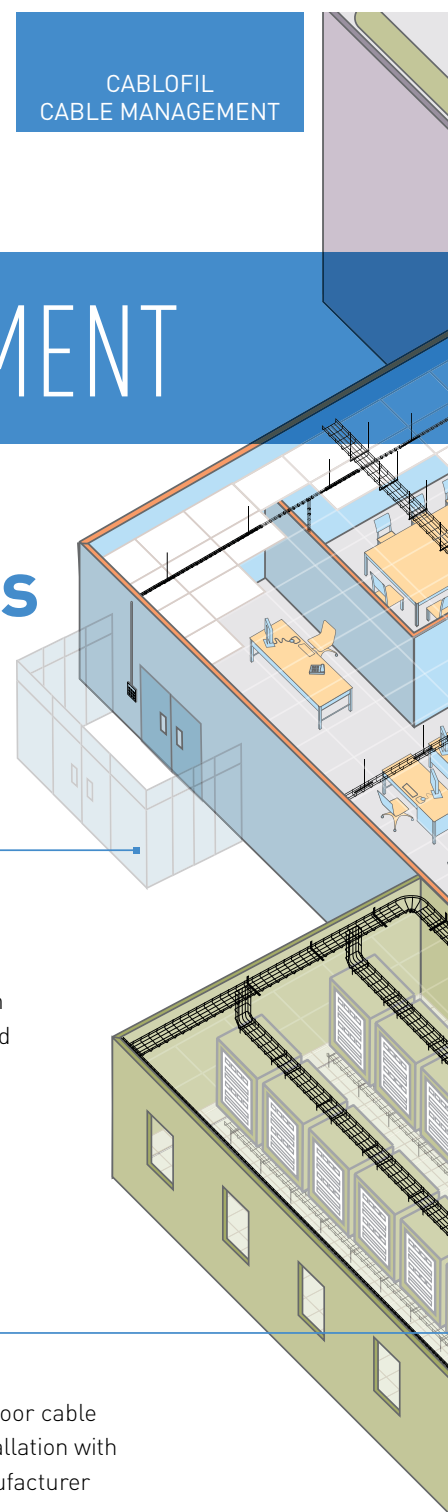

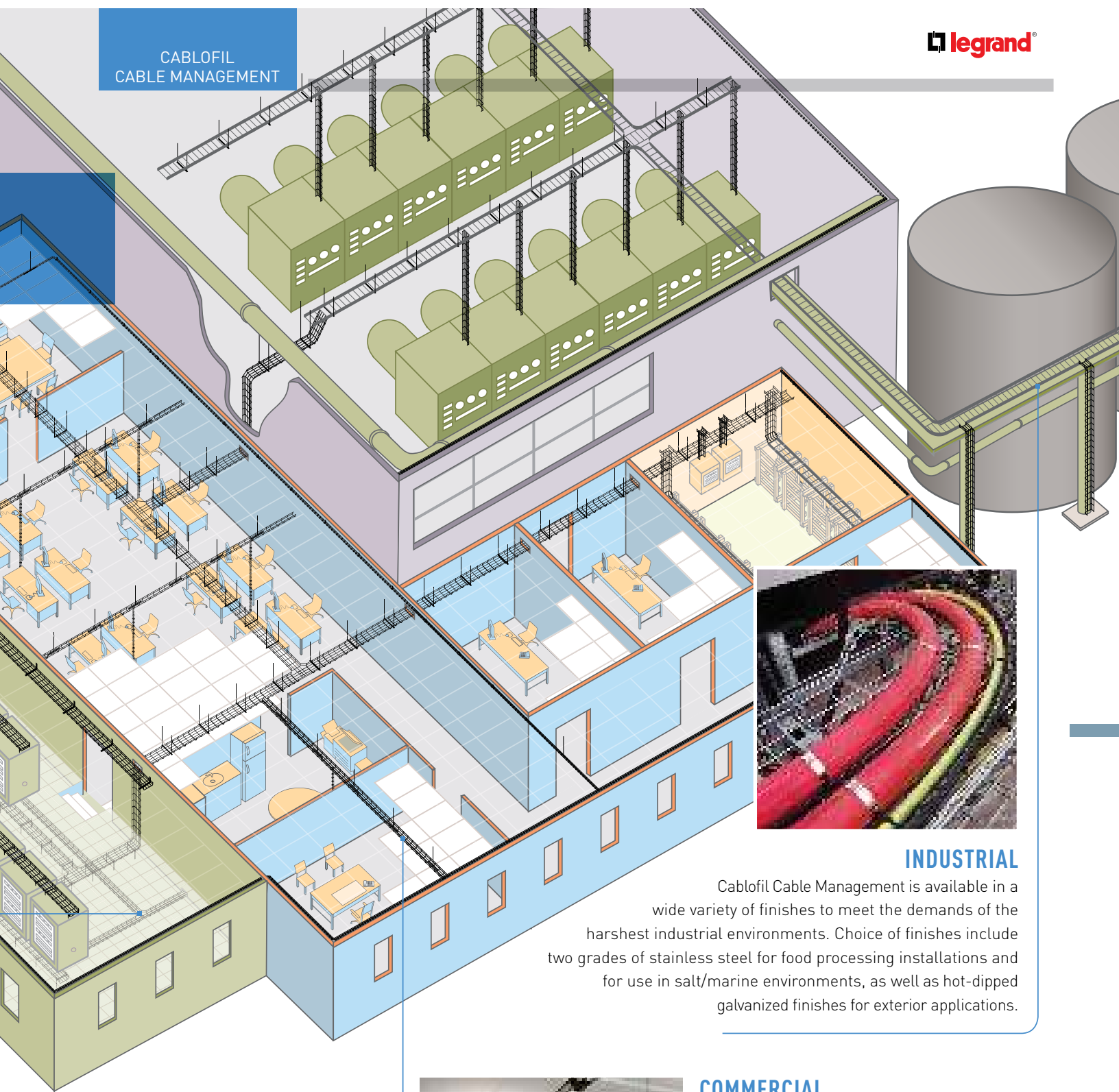

INDUSTRIAL

Cablofil Cable Management is available in a wide variety of finishes to meet the demands of the harshest industrial environments. Choice of finishes include two grades of stainless steel for food processing installations and for use in salt/marine environments, as well as hot-dipped galvanized finishes for exterior applications.



COMMERCIAL

Cablofil Cable Management is as good-looking as it is tough. All components are available in Black or Custom Color power-coated finishes for exposed installations in offices and public buildings, or in a cost-effective electrozinc finish for use above suspended ceilings.



CABLOFIL CABLE MANAGEMENT

Finishes and Product Features

Cablofil Cable Management is available in a variety of finishes to meet any industry need, from decorative to extreme environments. Use this chart to help you determine the best finish for your application and its availability.

SYMBOL	MATERIAL	FINISH & STANDARD	INTERIOR INSTALLATIONS	EXTERIOR INSTALLATIONS	PETROLEUM PLANTS CHEMICAL PLANTS	MARINE/SALT, WEAK SULPHUROUS ENVIRONMENTS	ACIDIC, ALKALINE ENVIRONMENTS	FOOD PRODUCTION, WASH-DOWN, CLEAN ROOMS	HALOGEN ENVIRONMENTS
PG	Carbon Steel ASTM A653	Pre-Galvanized: Continuous Galvanization Before Fabrication ASTM A 653	●						
EZ	Carbon Steel ASTM A510 Grade 1020	Electro zinc: Electro zinc plating ASTM B 633	●						
GC	Carbon Steel ASTM A510 Grade 1008	Hot Dipped Galvanized: After Fabrication ASTM A 123		●	●	●	●		
DC	Carbon Steel ASTM A510 Grade 1008	Geomet: Zinc and Aluminum Protection Equivalent to Hot Dip Galvanization ASTM F 1136		●	●	●	●		
304L	Stainless Steel AISI Type 304L	Stainless Steel 304L: Cleaned and Passivated ASTM A 380		●	●	●	●	●	●
316L	Stainless Steel AISI Type 316L	Stainless Steel 316L: Cleaned and Passivated ASTM A 380		●	●	●	●	●	●
BL	Carbon Steel ASTM A510 Grade 1008	Black Painted: Black Powder Coated ASTM D 3451	●						
PE	Carbon Steel ASTM A510 Grade 1008	Custom Painted: Custom Color Powder Coated ASTM D 3451	●						

For a more detailed explanation of finish standards and compatibility, visit www.legrand.us/cablofil.

● Recommended ● Possible

Galvanic Corrosion

Galvanic corrosion is the result of an electrochemical phenomenon due to the potential difference between different metals, or between a metal and the impurities it contains, when they are in electrical contact. Be aware of this phenomenon when selecting supports, splices and accessories. The results listed below are based on laboratory conditions and testing. However, in actual installations other conditions need to be considered to determine if significant galvanic reactions will occur.

RECOMMENDED COMPATIBILITY

CABLE TRAY	ACCESSORIES
PG / EZ	PG / EZ
GC	GC / DC
304L / 316L	316L

RECOMMENDED FOR TYPICAL CABLE TRAY

TRAY MATERIAL & FINISH	HARDWARE FINISH			
	ZINC-PLATED	GEOMET	GC	316L
Steel/EZ (Electrozinc)	●	●	●	●
Steel/GC (HDGAF)		●	●	●
Steel/BL (Painted)	●	●	●	●
Steel/PE (Painted)	●	●	●	●
Stainless-steel 304 (Passive)		●	●	●
Stainless-steel 316 (Passive)		●	●	●
Aluminum	●	●		●

● Recommended ● Possible

GALVANIC CORROSION TEXT RESULTS

SECONDARY MATERIAL (HARDWARE)	PRIMARY MATERIAL (TRAY)							
	STAINLESS-STEEL 304L	NICKLE	COPPER	BRASS	CARBON STEEL	ALUMINIUM	CHROMIUM	ZINC
Stainless-steel 304L	0							
Nickle	180	0						
Copper	320	140	0					
Brass	400	220	80	0				
Carbon Steel	750	570	430	350	0			
Aluminum	840	660	520	440	90	0		
Chromium	950	770	630	550	200	110	0	
Zinc	1150	970	830	750	400	310	200	0

The potential differences are expressed in millivolts. Shaded secondary materials in combination with primary materials listed above is not recommended.

Conditions

Lab Tests

- Submerged in seawater
- Equal mass materials
- Great connection

Typical Cable Tray Installation

- Wet/dry cycles not constant immersion
- Primary material may be 100 times greater
- Electrical current/connector

CABLOFIL PRODUCT CODE

Our part number makes it easy to identify part type, size and finish. Please use this code whenever ordering or specifying any Cablofil product.

FOR TRAY			
TYPE OF TRAY	DEPTH IN MM	WIDTH IN MM	FINISH CODE
CF	54	100	EZ

FOR SUPPORT AND OTHER PRODUCTS		
PRODUCT CODE	SIZE IN MM	FINISH CODE
FASC	300	PG

SYMBOLS LEGEND

Use these symbols to guide you through our catalog of innovative cable management products.



ASSEMBLY WITHOUT NUTS AND BOLTS



ASSEMBLY WITH NUTS AND BOLTS



FAST ASSEMBLY



NEW PRODUCT INNOVATION



SAFE EDGE™



PATENTED CABLOFIL PRODUCTS



PATENTED FAST ASSEMBLY SYSTEM™
FAS™
FAST ASSEMBLING SYSTEM



CABLOFIL CABLE MANAGEMENT

Quick Reference Load Table

Use this handy load guide to determine the capacity of your cable pathway. Always plan for extra space in cable pathways during the initial installation to allow capacity for future cable additions. For information on other cable sizes, go to www.legrand.us/cablofil/tools and use our online load calculator.



LOAD TABLE

TRAY	FILL AREA (sq. in.)	LOADS IN LBS/FT PER SPAN			
		5	6	7	8
CF54/50(2x2)	4.03	32.0	15.1	11.1	9.1
CF54/100(2x4)	8.06	39.4	22.3	16.4	15.9
CF54/150(2x6)	12.09	46.5	27.6	20.3	19.1
CF54/200(2x8)	16.12	54.2	36.4	26.7	24.7
CF54/300(2x12)	24.18	71.6	47.1	34.6	31.7
CF54/450(2x18)	36.27	134.9	91.0	66.8	60.3
CF54/600(2x24)	48.36	119.4	95.4	70.1	62.8
CF105/100(4x4)	15.97	68.3	46.4	34.1	30.5
CF105/150(4x6)	23.95	98.4	60.2	44.3	40.9
CF105/200(4x8)	31.93	109.4	76.2	56.0	51.9
CF105/300(4x12)	47.90	142.0	126.8	93.1	89.2
CF105/450(4x18)	71.84	151.0	129.9	95.4	88.7
CF105/600(4x24)	95.79	151.0	129.9	95.4	88.7
CF150/150(6x6)	34.41	127.5	123.0	90.4	89.1
CF150/200(6x8)	45.88	127.5	123.0	90.4	89.1
CF150/300(6x12)	68.82	175.9	155.0	113.9	98.3
CF150/450(6x18)	103.23	175.9	155.0	113.9	98.3
CF150/600(6x24)	137.64	228.5	165.7	121.7	91.3

DATA CABLE FILL TABLE

MC POWER CABLE FILL TABLE

TRAY	MAX NUMBER OF CABLES PER CODE				MAX NUMBER OF MC CABLES PER CODE			
	Cat 5e 4-pr Plenum (.17")	Cat 5e 4-pr Non-Plenum (.19")	Cat 6e 4-pr Plenum (.22")	Cat 6a 4-pr Plenum (.35")	2C (12 AWG) THHN TypeMC AlumArmor	3C (12 AWG) THHN TypeMC AlumArmor	3C (AWG 4/0) THHN TypeMC AlumArmor	3C (500 kcmil) THHN TypeMC AlumArmor
CF30/50(1x2)	47 cbls	38 cbls	28 cbls	11 cbls	11 cbls	10 cbls	–	–
CF30/100(1x4)	95 cbls	76 cbls	57 cbls	22 cbls	23 cbls	21 cbls	–	–
CF30/150(1x6)	43 cbls	114 cbls	85 cbls	33 cbls	35 cbls	31 cbls	–	–
CF30/200(1x8)	191 cbls	153 cbls	114 cbls	45 cbls	47 cbls	42 cbls	–	–
CF30/300(1x12)	286 cbls	229 cbls	171 cbls	67 cbls	71 cbls	63 cbls	–	–
CF54/50(2x2)	88 cbls	71 cbls	53 cbls	20 cbls	11 cbls	10 cbls	–	–
CF54/100(2x4)	177 cbls	142 cbls	106 cbls	41 cbls	23 cbls	21 cbls	2 cbls	1 cbl
CF54/150(2x6)	266 cbls	213 cbls	159 cbls	62 cbls	35 cbls	31 cbls	3 cbls	2 cbls
CF54/200(2x8)	355 cbls	284 cbls	212 cbls	83 cbls	47 cbls	42 cbls	5 cbls	3 cbls
CF54/300(2x12)	532 cbls	426 cbls	318 cbls	125 cbls	71 cbls	63 cbls	7 cbls	5 cbls
CF54/400(2x16)	710 cbls	568 cbls	424 cbls	167 cbls	95 cbls	84 cbls	10 cbls	7 cbls
CF54/450(2x18)	798 cbls	639 cbls	477 cbls	188 cbls	107 cbls	94 cbls	11 cbls	7 cbls
CF54/500(2x20)	887 cbls	710 cbls	530 cbls	209 cbls	119 cbls	105 cbls	12 cbls	8 cbls
CF54/600(2x24)	1065 cbls	852 cbls	636 cbls	251 cbls	143 cbls	126 cbls	15 cbls	10 cbls
CF105/100(4x4)	351 cbls	281 cbls	209 cbls	82 cbls	23 cbls	21 cbls	2 cbls	1 cbl
CF105/150(4x6)	527 cbls	422 cbls	314 cbls	124 cbls	35 cbls	31 cbls	3 cbls	2 cbls
CF105/200(4x8)	703 cbls	563 cbls	419 cbls	165 cbls	47 cbls	42 cbls	5 cbls	3 cbls
CF105/300(4x12)	1055 cbls	844 cbls	629 cbls	248 cbls	71 cbls	63 cbls	7 cbls	5 cbls
CF105/400(4x16)	1406 cbls	1126 cbls	839 cbls	331 cbls	95 cbls	84 cbls	10 cbls	7 cbls
CF105/450(4x18)	1582 cbls	1266 cbls	944 cbls	373 cbls	107 cbls	94 cbls	11 cbls	7 cbls
CF105/500(4x20)	1758 cbls	1407 cbls	1049 cbls	414 cbls	119 cbls	105 cbls	12 cbls	8 cbls
CF105/600(4x24)	2110 cbls	1689 cbls	1259 cbls	497 cbls	143 cbls	126 cbls	15 cbls	10 cbls
CF150/150(6x6)	788 cbls	631 cbls	469 cbls	186 cbls	23 cbls	21 cbls	3 cbls	2 cbls
CF150/200(6x8)	1010 cbls	809 cbls	603 cbls	238 cbls	47 cbls	42 cbls	5 cbls	3 cbls
CF150/300(6x12)	1515 cbls	1213 cbls	905 cbls	357 cbls	71 cbls	63 cbls	7 cbls	5 cbls
CF150/400(6x16)	2021 cbls	1618 cbls	1206 cbls	476 cbls	95 cbls	84 cbls	10 cbls	7 cbls
CF150/450(6x18)	2273 cbls	1820 cbls	1357 cbls	536 cbls	107 cbls	94 cbls	11 cbls	7 cbls
CF150/500(6x20)	2526 cbls	2022 cbls	1508 cbls	596 cbls	119 cbls	105 cbls	12 cbls	8 cbls
CF150/600(6x24)	3031 cbls	2427 cbls	1810 cbls	715 cbls	143 cbls	126 cbls	15 cbls	10 cbls



CABLE MANAGEMENT

Designed to be Better

Cablofil Cable Management is constructed of precision engineered, high quality, welded steel wire and is the result of decades of research gained from the installation of 125,000 miles of tray across the globe. Our tray is subjected to testing at every stage of the manufacturing process. In actual use, it has performed in a wide variety of applications from heavy power cable pathways on oil drilling platforms in the North Sea, to data installation above the ceiling in modern office buildings.

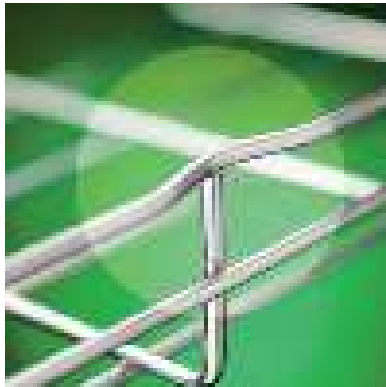
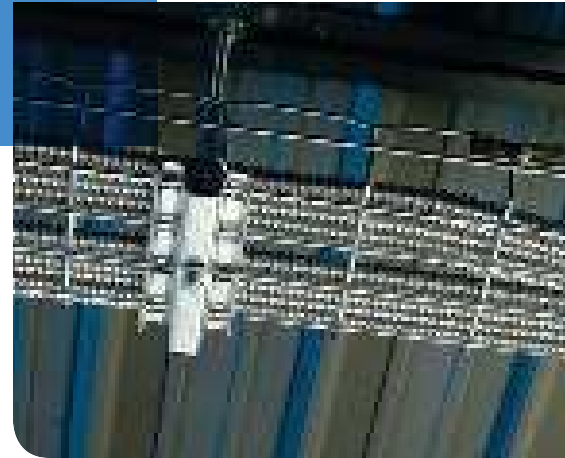

SAFE-T-EDGE

Our unique Safe-T-Edge design involves "T" welding the lateral wires to the bottom edge of the top wires, which eliminates sharp edges and creates a smooth cable pathway that's safe for cables and installers. This is most important when adding or changing cables in your cable pathway.

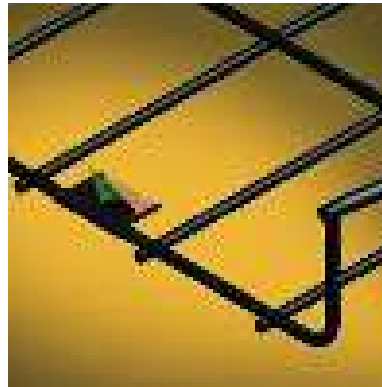

UL CLASSIFIED PAINTED WIRE CABLE TRAY

Our UL Classified painted wire tray meets NEC392 from the National Electric Code that states, "all cable tray systems must be properly BONDED, per 250.96". It is also UL Classified as an EGC (Equipment Grounding Conductor). Installation requires a SWK splice on adjoining tray bottoms that features a copper strip.



PATENTED OPTIMIZED WIRE DESIGN

The diameter of key wires in Cablofil is optimized to the exact diameter necessary, enabling the tray to support the greatest working load. While other manufacturers advocate larger wire sizes for greater strength, Legrand reviews product performance using best-tested method for in-field use. This optimized wire design is patented in the US and around the world.

CERTIFICATIONS

Cablofil Cable Managements have been independently evaluated by UL, CSA, ABS, DNV, ETL, and VDE to meet applicable standards and requirements. Our products hold UL Classification to NEC requirements, cCSAus certification to NEMA & CSA requirements, ABS Product Design Assessment certification, and E90 certification. Our products also meet the standards requirements of IEC, EIA-TIA, and BICSI. For more information on Cablofil certifications, please visit www.legrand.us/cablofil.

MEMBERSHIPS:

NEMA, CTI, EIA-TIA, NFPA, IEC, BICSI

REGISTERED TO
 ISO 9001:2000





CF 30	A.12
1" DEEP TRAY	
CF 54	A.12
2" DEEP TRAY	
CF 105	A.13
4" DEEP TRAY	
CF 150	A.13
6" DEEP TRAY	
UL CLASSIFIED PAINTED WIRE CABLE TRAY	A.14
PACKCF	A.14
EASY PACK	
CFG	A.15
G-TRAY	
G-MINI	
CFL	A.15
L-TRAY	
TXF 35	A.16
TELEX RAIL	
CTXF 35	A.16
TELEX RAIL COVER	
UC 35	A.16
TELEX RAIL STANDOFF SUPPORT	
TRAY INSERT	A.16
FCF 54	A.17
FASCLIC	
CVN	A.17
COVER	
CLIP F02	A.17
COVER CLIP	
COTFIL50/COTFIL100	A.18
SNAP-IN WIRE DIVIDERS	
COT F	A.18
FLEXIBLE DIVIDER	
COT 30/COT54	A.19
DIVIDER STRIP	
COT 105/COT 150	A.19
DIVIDER STRIP	
COT J	A.19
DIVIDER COUPLER	

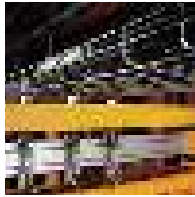

LOAD TESTING

Cablofil Cable Management has been engineered and tested per NEMA VE1 to support loads that exceed its fill capacity. For exact data on load capacity, testing methods and support placement, please visit www.legrand.us/cablofil.

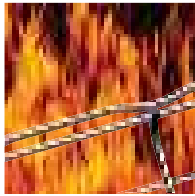

RESISTANCE TO FIRE

Cablofil Cable Management is certified E-30 to E-90. This German standard is the only certification of its kind in the world and requires that the tray and its supports withstand 1000° C or 1832° F heat for a period of 90 minutes. This is an important safety consideration when planning fire exit routes from a burning building.



EXCELLENT EMC

Testing by independent laboratories show that Cablofil Cable Management, when installed and earthed correctly, significantly reduces electromagnetic disturbances. The steel structure of the tray absorbs EMI and drains the disturbance away from cables causing minimal effect to the connected equipment. Cable pathways constructed of aluminum alloys or plastics have no effect on EMI reduction.

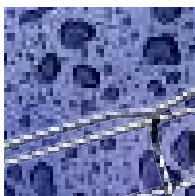

ELECTRICAL CONTINUITY

Cablofil Cable Management and our wide range of splices are tested and comply with CSA, IEC, NEC, NEMA and UL requirements for low resistance. Excellent electrical continuity and grounding is essential for safe installations and reduces shock hazards.

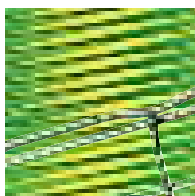

STEEL GRADE QUALITY

Our tray is constructed of precision engineered, high quality steel wire. ISO 9000 certified, Cablofil Cable Management is subjected to rigorous quality control at every stage of the manufacturing processes.



CF 30 / ZF30
CABLOFIL CABLE TRAY

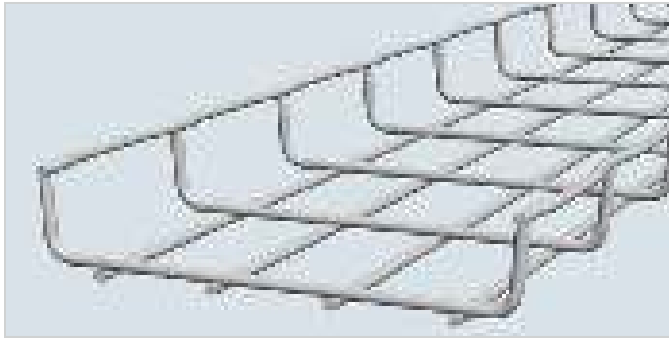

Cablofil's Optimized Wire Size, Tray Patent Number – 6.138.961

	HEIGHT		WIDTH		LENGTH		WEIGHT		EZ
	INCHES	MM	INCHES	MM	FEET	M	LBS	KG	
ZF 30/50*	1.0	30	2.0	50	10.0	3	3.3	1.5	–
CF 30/100	1.0	30	4.0	100	10.0	3	4.5	2.0	–
CF 30/150	1.0	30	6.0	150	10.0	3	5.7	2.6	–
CF 30/200	1.0	30	8.0	200	10.0	3	7.4	3.3	–
CF 30/300	1.0	30	12.0	300	10.0	3	9.4	4.3	–

*Products listed as "ZF" are only available in Straight Edge Tray.
– Contact manufacturer for availability.

CF 54
CABLOFIL CABLE TRAY

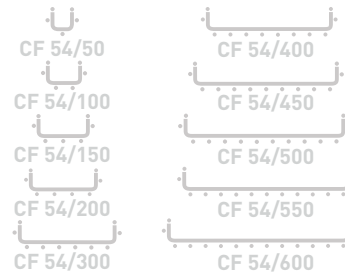
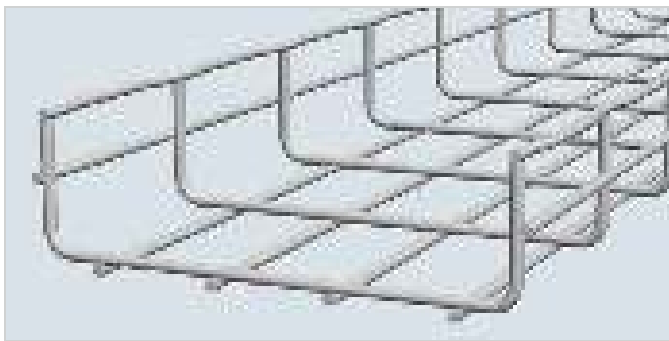

Cablofil's Optimized Wire Size, Tray Patent Number – 6.138.961

Other sizes available. Contact Legrand.

	HEIGHT		WIDTH		LENGTH		WEIGHT		EZ	GC	304L	316L	BL	PE
	INCHES	MM	INCHES	MM	FEET	M	LBS	KG						
CF 54/50	2.0	54	2.0	50	10.0	3	5.3	2.4	000 061	–	–	–	941 101	934 056
CF 54/100	2.0	54	4.0	100	10.0	3	6.5	3.0	000 071	–	–	–	941 102	934 095
CF 54/150	2.0	54	6.0	150	10.0	3	7.8	3.5	000 081	–	–	–	941 103	934 130
CF 54/200	2.0	54	8.0	200	10.0	3	9.0	4.1	000 091	–	–	–	941 104	934 158
CF 54/300	2.0	54	12.0	300	10.0	3	13.4	6.1	000 101	–	–	–	941 105	933 901
CF 54/400	2.0	54	16.0	400	10.0	3	20.0	9.1	000 201	–	–	–	941 107	933 918
CF 54/450	2.0	54	18.0	450	10.0	3	22.8	10.3	000 251	–	–	000 254	941 108	933 928
CF 54/500	2.0	54	20.0	500	10.0	3	24.4	11.0	000 301	–	–	–	941 109	933 932
CF 54/550	2.0	54	22.0	550	10.0	3	25.9	11.7	941 001	–	–	–	942 288	942 360
CF 54/600	2.0	54	24.0	600	10.0	3	27.5	12.5	000 401	–	–	–	941 110	933 944

– Contact manufacturer for availability.



CF 105 CABLOFIL CABLE TRAY

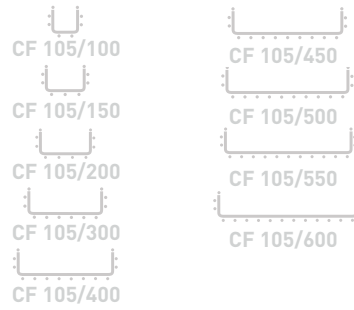

Other sizes available. Contact Legrand.

Cablofil's Optimized Wire Size, Tray Patent Number – 6.138.961

	HEIGHT		WIDTH		LENGTH		WEIGHT		EZ	GC	304L	316L	BL	PE
	INCHES	MM	INCHES	MM	FEET	M	LBS	KG						
CF 105/100	4.0	105	4.0	100	10.0	3	9.0	4.1	000 891	–	–	–	941 114	934 146
CF 105/150	4.0	105	6.0	150	10.0	3	10.2	4.6	000 901	–	–	–	941 115	934 152
CF 105/200	4.0	105	8.0	200	10.0	3	13.4	6.1	000 911	000 913	000 918	000 914	941 116	934 160
CF 105/300	4.0	105	12.0	300	10.0	3	21.2	9.6	000 921	–	–	–	941 118	934 163
CF 105/400	4.0	105	16.0	400	10.0	3	23.0	10.4	000 931	–	–	–	941 119	934 167
CF 105/450	4.0	105	18.0	450	10.0	3	25.9	11.8	001 931	–	–	–	942 463	942 462
CF 105/500	4.0	105	20.0	500	10.0	3	27.5	12.5	000 941	–	000 948	–	941 120	934 170
CF 105/550	4.0	105	22.0	550	10.0	3	29.0	13.0	001 941	–	–	–	–	–
CF 105/600	4.0	105	24.0	600	10.0	3	30.4	13.8	001 031	–	–	001 034	941 127	933 905

– Contact manufacturer for availability.

CF 150 / ZF 150 CABLOFIL CABLE TRAY

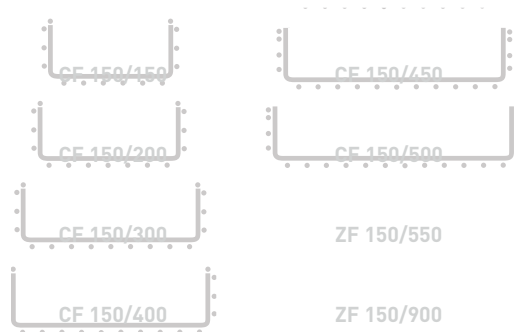
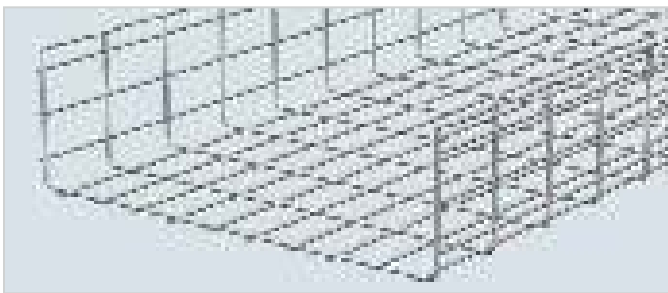

Other sizes available. Contact Legrand.

	HEIGHT		WIDTH		LENGTH		WEIGHT		EZ	GC	304L †	316L †	BL	PE
	INCHES	MM	INCHES	MM	FEET	M	LBS	KG						
CF 150/150	6.0	150	6.0	150	10.0	3	18.9	8.6	000 981	–	–	–	941 124	934 178
CF 150/200	6.0	150	8.0	200	10.0	3	21.8	9.9	000 951	000 953	–	–	941 121	934 172
CF 150/300	6.0	150	12.0	300	10.0	3	24.4	11.0	000 961	–	–	–	941 122	934 174
CF 150/400	6.0	150	16.0	400	10.0	3	25.8	11.7	000 971	–	–	–	941 123	934 176
CF 150/450	6.0	150	18.0	450	10.0	3	26.5	12.0	001 011	–	–	–	941 125	933 902
CF 150/500	6.0	150	20.0	500	10.0	3	27.8	12.6	001 021	–	–	–	941 126	933 903
ZF 150/550**	6.0	150	22.0	550	10.0	3	28.7	13.0	941 000	–	–	–	942 287	942 359
ZF 150/900**	6.0	150	36.0	900	10.0	3	34.6	15.7	943 161	–	–	–	943 783	–

– Contact manufacturer for availability.

**Products listed as "ZF" are only available in Straight Edge Tray.

†Available as "ZF" only.



UL CLASSIFIED PAINTED WIRE CABLE TRAY

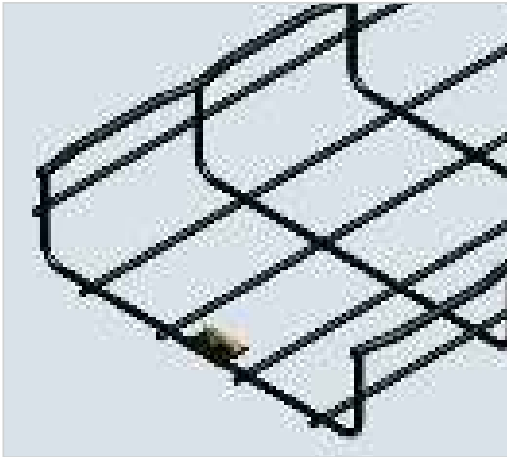

- Industry's only UL-Classified painted wire cable tray per NEC 392.
- Standard on all Cablofil BL or PE.

Directions for use:

1. Remove outer mask of folded copper strip (that has been painted over) at the end of each section tray.
2. Splice tray section with SWK splice (**page A.24**) on copper strip of adjoining trays to maintain proper bonding.

PACKCF CABLOFIL EASY PACK



- Easy Pack is a conveniently packaged, all inclusive and ready to install cable management system.
- Stop in at your local distributor showroom and get the products you need right away.
- Great for small jobs and making additions to existing installations.
- Installation instructions and splicing hardware are included. Just cut, bend and install—it's that easy.
- Can be shipped via parcel service.

Each Easy Pack includes:

- 2" Easy Pack contains (6) 78" sections (39') of 2" deep Cablofil Tray and 12 Preclick splices.
- 4", 6" and 8" Easy Pack contains (4) 78" sections (26') of 2" deep Cablofil Tray and 8 Preclick splices.
- 12" Easy Pack contains (4) 78" sections (26') of 2" deep Cablofil Tray, 8 Preclick splices and 4 SWK bolts.
- Easy installation instructions.

	HEIGHT		WIDTH		LENGTH		WEIGHT		EZ
	INCHES	MM	INCHES	MM	FEET	M	LBS	KG	
PACKCF 54/50	2.0	54	2.0	50	39.0	12	26.5	12.0	800 211
PACKCF 54/100	2.0	54	4.0	100	26.0	8	24.3	11.0	800 221
PACKCF 54/150	2.0	54	6.0	150	26.0	8	26.5	12.0	800 231
PACKCF 54/200	2.0	54	8.0	200	26.0	8	28.7	13.0	800 241
PACKCF 54/300	2.0	54	12.0	300	26.0	8	37.5	17.0	800 261

CFG CABLOFIL G-TRAY AND G-MINI

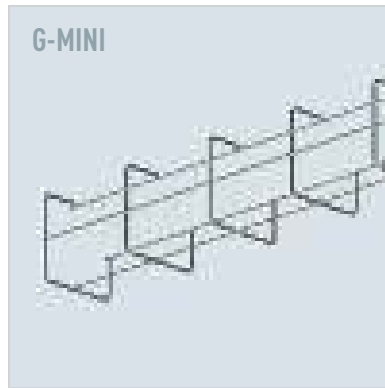

- Unique curved top allows for direct attachment to machinery, ceilings or walls.
- Use CE40 for CFG support attachment.
- 3" overhang on G-Tray allows for direct-mounting in many configurations.
- Unique crosswire design easily bends and lies flat when mounting.
- Use CE25 for G-Mini support attachment.
- G-Mini is a simple and secure routing for small cable runs.
- Use SWK (page A.24) for splicing.

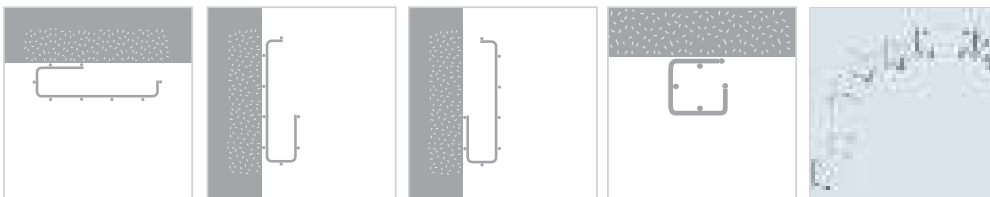

		HEIGHT		WIDTH		LENGTH		WEIGHT		EZ	GC	304L	316L	BL	PE
		INCHES	MM	INCHES	MM	FEET	M	LBS	KG						
CFG 50/100		2.0	50	4.0	100	10.0	3	7.0	3.2	–	–	–	–	941 143	933 935
CFG 50/150		2.0	50	6.0	150	10.0	3	10.3	4.7	–	–	–	–	943 114	–
CFG 50/200		2.0	50	8.0	200	10.0	3	10.3	4.7	–	–	–	–	941 144	933 937
G-MINI		2.0	50	2.0	50	10.0	3	8.8	4.0	–	–	–	430 114	–	–

– Contact manufacturer for availability.

CFL CABLOFIL L-TRAY

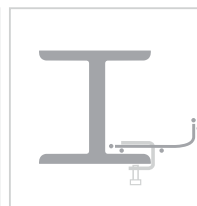
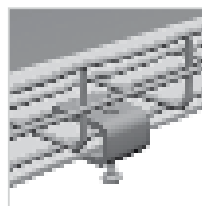
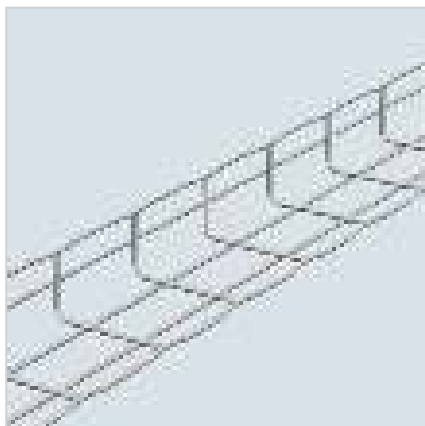

- Can be configured to any installation.
- For ETC Tray Beam Support see page D.10.

	HEIGHT		WIDTH		LENGTH		WEIGHT		EZ	GC	304L	316L	BL	PE
	INCHES	MM	INCHES	MM	FEET	M	LBS	KG						
CFL 54/100	2.0	54	4.0	100	10.0	3	5.3	2.4	942 769	–	–	–	942 772	942 773

– Contact manufacturer for availability.



TXF 35 TELEX RAIL

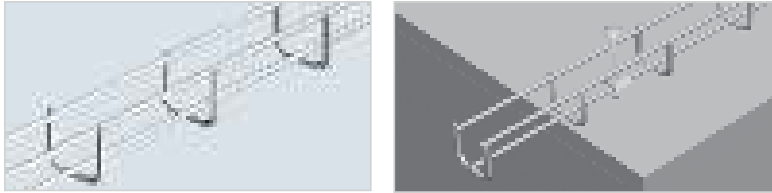

- Unique wire arrangement allows tray to lay flat on cabinets or machinery without rocking.
- Use in applications where small runs of cable are needed.
- Use SWK splice hardware.

	HEIGHT	WIDTH		LENGTH		WEIGHT		EZ	GC	304L	316L	BL	PE	
		INCHES	MM	INCHES	MM	FEET	M	LBS	KG					
TXF 35	1.0	35	1.0	35	10.0	3	3.3	1.5	755 001	755 003	755 008	755 004	941 407	931 142

CTXF 35 TELEX RAIL COVER



- Cover eliminates dirt and dust build-up on cable.
- Field fabricates on-site to fit changes in levels.
- Provides physical protection for cables.
- Use built-in tabs for permanent attachment to tray.

	WIDTH		LENGTH		WEIGHT		PG	GC	316L	BL	PE
	INCHES	MM	FEET	M	LBS	KG					
CTXF 35	1.0	35	10.0	3	2.7	1.2	755 100	–	–	942 611	–

– Contact manufacturer for availability.

UC 35 TELEX RAIL STANDOFF SUPPORT

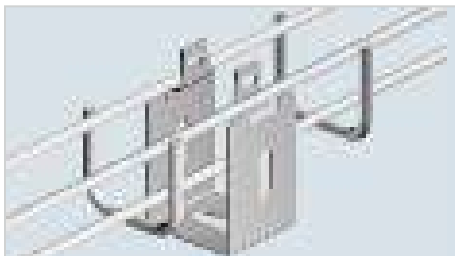

- Specially designed to attach Telex rail to cabinet tops and channel framing.
- Fold over tabs secure tray without nuts and bolts. Just snap tray in place.

	WIDTH		WEIGHT		PG	GC	316L	BL	PE
	INCHES	MM	LBS	KG					
UC 35	1.5	40	1.1	0.5	586 160	–	586 164	942 754	942 755

INSERT TRAY INSERT

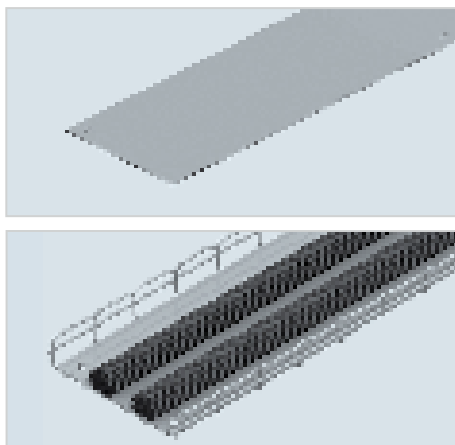

- Use Tray Insert to protect cables in underside of tray.
- Bend over tabs to secure insert to tray.

	PKG. QTY.	WIDTH		LENGTH		WEIGHT		PG
		INCHES	MM	INCHES	M	LBS	KG	
Insert 100	2	3.39	86	58.75	1.5	2.5	1.1	942 420
Insert 150	2	5.39	137	58.75	1.5	4.47	2.0	942 421
Insert 200	2	7.36	187	58.75	1.5	5.0	2.3	942 422
Insert 300	2	11.34	288	58.75	1.5	8.6	3.9	942 426
Insert 450	2	17.36	441	58.75	1.5	12.5	5.7	942 427
Insert 500	2	19.33	491	58.75	1.5	13.75	6.2	942 428
Insert 600	2	23.39	594	58.75	1.5	15.0	6.8	942 430
Insert 900	2	35.20	894	58.75	1.5	52.5	23.8	943 367

FCF 54 FASCLIC TRAY

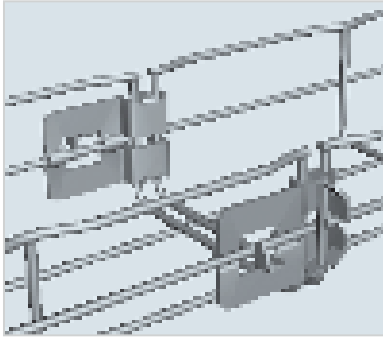

- FCF 54 includes pre-installed splices to speed install time.
- Locking tabs make for a secure splice.

ASSEMBLY

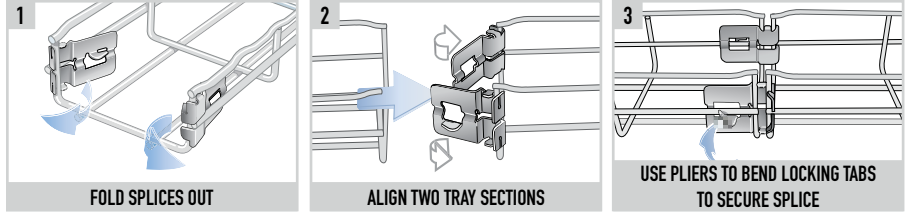

		HEIGHT		WIDTH		LENGTH		WEIGHT		EZ
		INCHES	MM	INCHES	MM	FEET	M	LBS	KG	
FCF 54/50		2.0	54	2.0	50	10.0	3	5.3	2.4	081 061
FCF 54/100		2.0	54	4.0	100	10.0	3	6.6	3.0	081 071

CVN CABLOFIL COVER

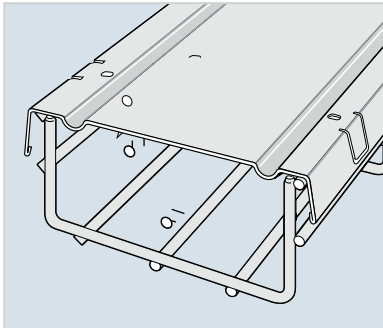

- Cover eliminates dirt and dust build-up on cable.
- Field fabricate on-site to fit changes in levels.
- Use built-in tabs for permanent attachment to tray.
- 3- 3.3' covers are included in each package to cover 1-10' section of Cablofil tray.

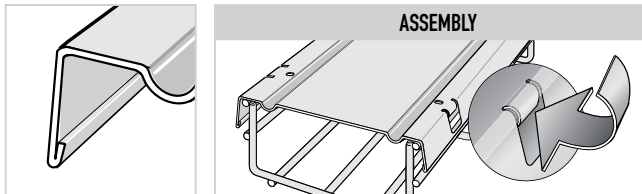

	PKG. QTY.	WIDTH		LENGTH		WEIGHT		PG	GC	316L	BL	PE
		INCHES	MM	FEET	M	LBS	KG					
CVN 50	3	2.0	71	3.3	1	2.6	1.2	629 050	629 053	629 054	941 332	934 071
CVN 100	3	4.0	121	3.3	1	4.6	2.1	629 100	629 103	629 104	941 333	934 073
CVN 150	3	6.0	171	3.3	1	7.3	3.3	629 150	629 153	629 154	941 334	934 075
CVN 200	3	8.0	221	3.3	1	9.3	4.2	629 200	629 203	629 204	941 335	934 077
CVN 300	3	12.0	322	3.3	1	13.2	6.0	629 300	629 303	629 304	941 336	934 079
CVN 450	3	18.0	475	3.3	1	22.5	10.2	629 450	-	-	941 338	934 083
CVN 500	3	20.0	525	3.3	1	28.4	12.9	629 500	-	-	941 339	934 085
CVN 600	3	24.0	625	3.3	1	33.1	15.0	629 600	-	-	941 340	934 087

- Contact manufacturer for availability.

CLIP F02 COVER CLIP

- Use for installations where cover (CVN) is removed frequently.

	PKG. QTY.	WEIGHT		PG	316L	BL	PE
		LBS	KG				
CLIP F02	25	2.2	1.0	646 200	646 204	942 807	942 808

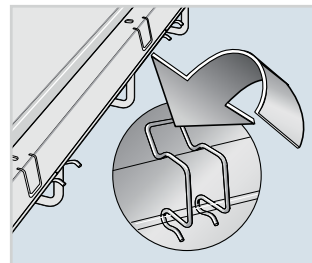

COTFIL50/COTFIL100
SNAP-IN WIRE DIVIDERS

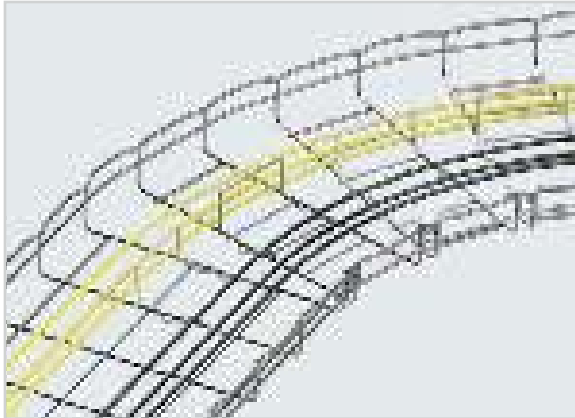

- Keeps different cabling types separated in a single pathway
- Mount on straight sections, tees, crosses, junctions and sweeps
- Specific sizes available for CF54 and CF105 series Cablofil Cable Management
- Snaps-in, requiring no additional hardware
- Patented

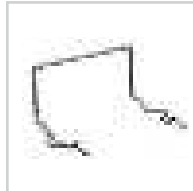

	PKG. QTY.	SIZE		WEIGHT		EZ
		INCHES	MM	LBS	KG	
COTFIL50	12	2	50	.91	.412	586 721
COTFIL100	12	4	100	1.04	.471	586 728

COT F
FLEXIBLE DIVIDER

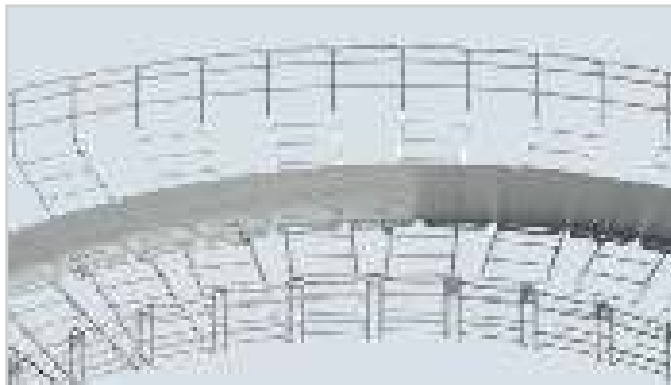

- Separates cables on sweeps and bends.
- Allows for installation of power cables and data cables within the same pathway.
- Attaches to Cablofil tray using three sets of EZ BN 1/4 and CE 25.



	PKG. QTY.	HEIGHT		LENGTH		WEIGHT		PG	GC	304L	316L	BL	PE
		INCHES	MM	FEET	METERS	LBS	KG						
COTF54 KIT	1	2.0	54	6.0	2	1.07	0.49	943 423	–	–	–	943 426	943 427
COTF105 KIT	1	4.0	105	6.0	2	2.14	0.97	943 428	–	–	–	943 431	943 432
COTF150 KIT	1	6.0	150	6.0	2	3.21	1.46	943 433	–	–	–	943 436	943 437

– Contact manufacturer for availability.



COT 30/COT 54 DIVIDER STRIP

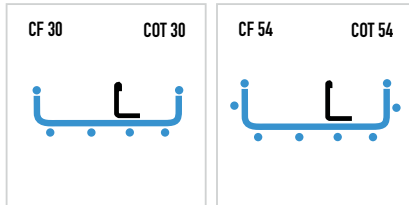
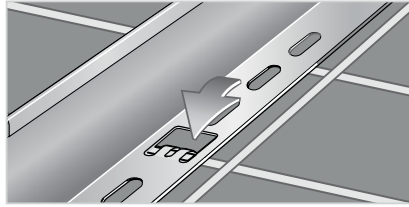
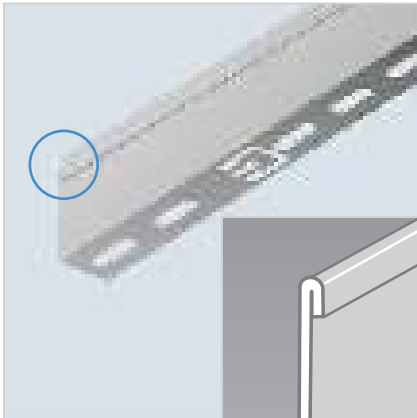

- For cable separation within a single tray.
- Attach to tray with fold-over tabs or with EZ BN 1/4 and CE 25 (sold separately – see pg. A.81).
- Field fabricate with tin snips for changes in levels.

	HEIGHT		LENGTH		WEIGHT		PG	GC	316L	BL	PE
	INCHES	MM	FEET	M	LBS	KG					
COT 30	1.0	30	10.0	3	2.0	0.9	923 010	–	–	942 283	933 889
COT 54	2.0	54	10.0	3	2.8	1.3	923 020	923 023	923 024	942 284	933 891

– Contact manufacturer for availability.

COT 105/COT 150 DIVIDER STRIP

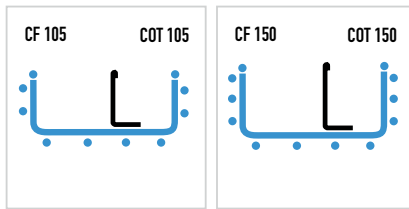
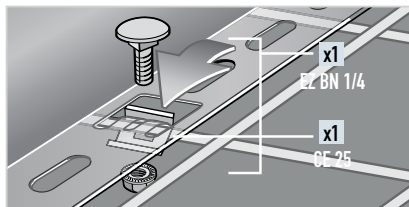
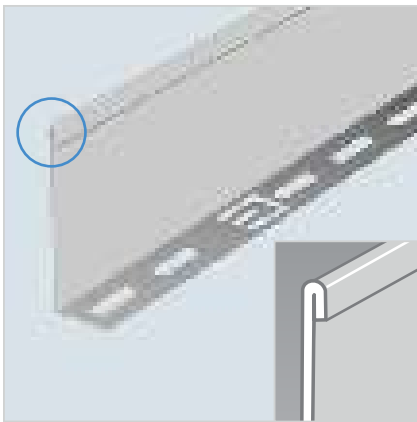

- For cable separation within a single tray.
- Field fabricate with tin snips to fit changes in levels.
- Requires EZ BN 1/4 and CE 25 to attach to tray (included).
- COT 150 does not have tabs.

	HEIGHT		LENGTH		WEIGHT		PG	GC	316L	BL	PE
	INCHES	MM	FEET	M	LBS	KG					
COT 105 KIT	4.0	105	10.0	3	4.7	2.1	943 413	943 414	943 415	943 416	943 417
COT 150 KIT	6.0	150	10.0	3	6.6	3.0	943 418	–	–	943 421	943 422

– Contact manufacturer for availability.

COT J DIVIDER COUPLER

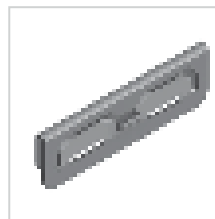

- Improves electrical continuity and strengthens dividers.
- Can be removed with a screwdriver and is reusable.

	PKG. QTY.	WEIGHT		AL	PG	316L
		LBS	KG			
COT J	25	0.026	0.012	943 390	923 050	923 054



SPLICING

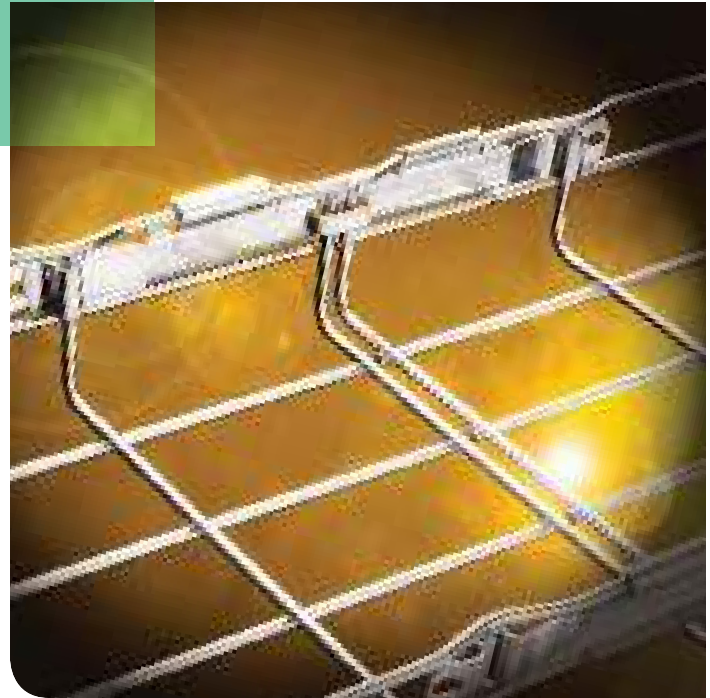

- A.21 EDRN**
FAST SPLICE
- A.21 EDRNTOOL**
MOUNTING TOOL
- A.21 PRECLICK**
SPLICE
- A.22 EXPANKIT**
EXPANSION KIT
- A.22 EDRSKIT**
TRAY REDUCTION KIT
- A.23 EDT**
SPLICE PLATE
- A.23 ED 275**
UNIVERSAL SPLICE BAR
- A.24 SWK**
SPLICE WASHER KIT
- A.24 CE 40**
SQUARE SPLICE WASHER
- A.25 CE 25/CE30**
SQUARE SPLICE WASHER
- A.25 CE 35**
CLAMPING WASHER
- A.26 FASLOCK**
SPLICE
- A.26 EAC KIT**
ELEVATION CHANGE HINGE
- A.26 EZT 90 KIT**
90° AND TEE BEND KIT
- A.27 RADT 90 KIT**
RADIUS TEE 90° KIT
- A.27 RADT 9012 KIT**
12" RADIUS TEE 90° KIT

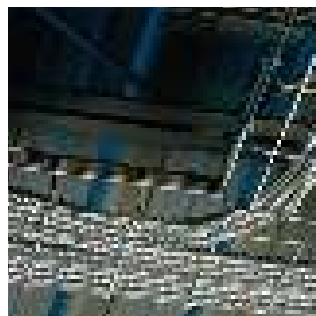
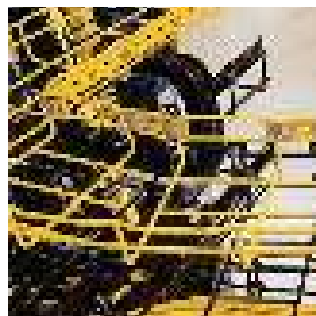

Cablofil has a splice for every need. Our EDRN is the fastest splice we offer saving up to half the installation time compared to bolted connections. Other splices are available that help installers give your installation additional strength or have improved electrical continuity. The choice is yours.

For more information on splicing Cablofil Cable Management, please go to www.legrand.us/cablofil.

EDRN / EDRNTOOL FAST SPLICE

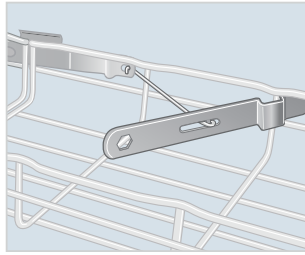
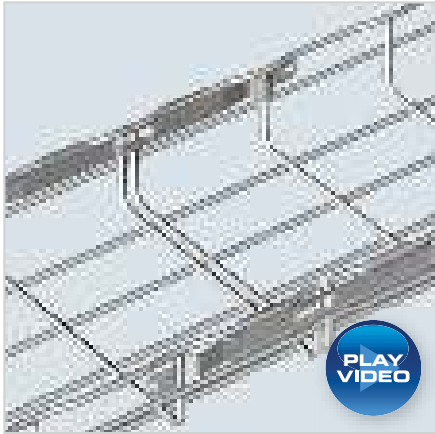

EDRNTOOL

- Fastest splice available from the Cablofil product line. Saves up to half the install time compared to bolted connections.
- Special assembly tool (EDRNTOOL) is included in every bag of splices.
- UL Classified Splice.
- Additional mounting tool for use with EDRN splice.
- 7/16 hex in handle doubles as a SWK wrench.

	PKG. QTY.	WEIGHT		EZ	DC	316L	BL	PE
		LBS	KG					
EDRN	25	3.9	1.75	–	–	558 244	–	–
	50	8.8	4.0	558 241	558 247	–	941 281	934 032
EDRNTOOL	1	0.2	0.09	–	–	–	943 408	–

– Contact manufacturer for availability.

SPLICING GUIDELINES

CF30 – CF54 – CF105 – CF150	2" → 8" (50 → 200 mm)	12" (300 mm)	18" → 24" (450 → 600 mm)
EDRN splices needed on side wires	2x EDRN	2x EDRN	2x EDRN
EDRN splices needed on bottom of tray	–	1x EDRN	2x EDRN

See installation instructions on page A.86.

PRECLICK SPLICE



- Installation is fast and easy—only a screwdriver is required to snap the splices in place.
- Square holes allows for bolted connections.
- SWK is sold separately. **See p. A.81.**

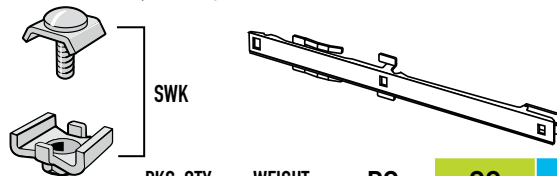

	PKG. QTY.	WEIGHT		PG	GC	316L	BL	PE
		LBS	KG					
PRECLICK	8	1.7	0.8	942 735	–	942 739	942 738	942 737

– Contact manufacturer for availability.

SPLICING GUIDELINES

CF54 – CF105 – CF150	2" → 8" (50 → 200 mm)	12" (300 mm)	18" → 24" (450 → 600 mm)
PRECLICK splices needed on side wires	2x PRECLICK	2x PRECLICK	2x PRECLICK
SWK splices needed on bottom of tray	–	1x SWK	2x SWK

See installation instructions on page A.86.



EXPANKIT EXPANSION KIT

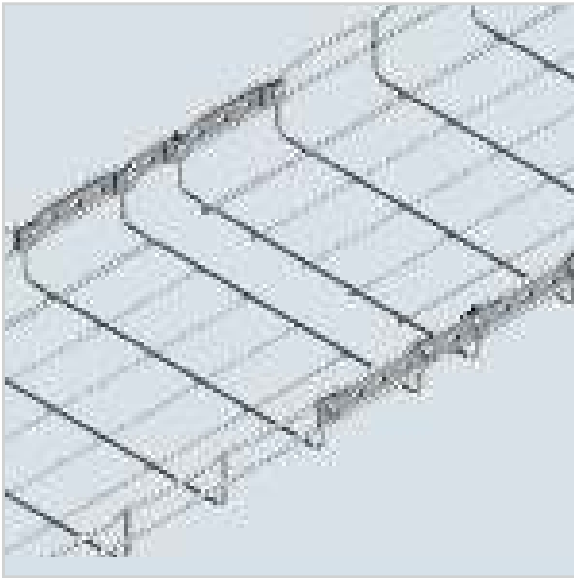

- Allows expansion between two pieces of tray
- Can be cut to fit with a bolt cutter.
- Can be bent by hand for use in tees, elbows, etc.
- UL Classified Splice.
- Slots (.22" x .28") are on .98" centers.

	PKG. QTY.	WEIGHT		EZ	316L
		LBS	KG		
EXPANKIT	1	14.4	6.5	943 122	—

– Contact manufacturer for availability.

EDRSKIT TRAY REDUCTION KIT

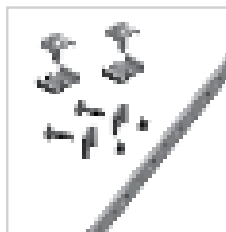
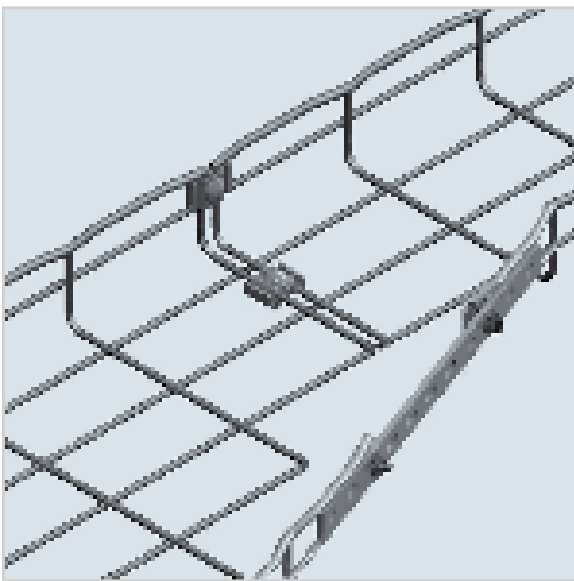

- Each kit includes two SWK, one ED 275 (or ED 1100), two EZ BN 1/4 and two CE 25.
- ED 275 and ED 1100 can be trimmed to any length with a shear or bolt cutter if needed.

	PKG. QTY.	WEIGHT		EZ	304L	BL	PE
		LBS	KG				
ED275RSKIT*	1	0.3	0.15	943 202	—	943 441	944 590
ED1100RSKIT†	1	1.2	0.6	943 221	—	944 396	—

– Contact manufacturer for availability.

*Use on tray differences up to 8"

†Use on tray differences over 8"

EDT SPLICE PLATE

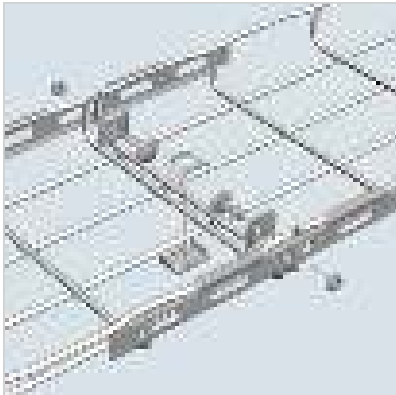

- Splices are specially designed to join two sections of CF 30 Cablofil tray.
- EZ BN 1/4, CE 25 and SWK are sold separately. **(see pg. A.81).**
- UL Classified Splice.

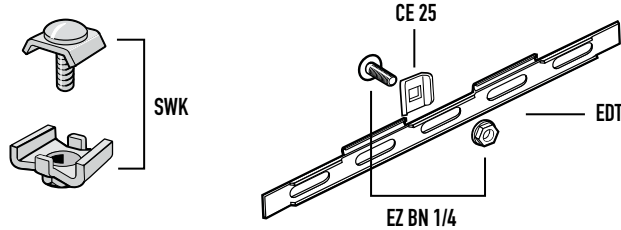

	PKG. QTY.	WEIGHT		EZ	316L	BL	PE
		LBS	KG				
EDT	50	6.6	3.0	558 251	558 254	941 282	934 034

CF30 – CF54 – CF105 – CF150	2" (50 mm)	4" → 8" (100 → 200 mm)	12" → 24" (300 → 600 mm)
EDT splices needed for side wires	2x CE 25, EZ BN 1/4, EDT	2x CE 25, EZ BN 1/4, EDT	2x CE 25, EZ BN 1/4, EDT
SWK splices needed on bottom of tray	–	1x SWK	2x SWK

ED 275 UNIVERSAL SPLICE BAR



- Can be cut to fit with a bolt cutter.
- Can be bent by hand for use in tees, elbows, etc.
- EZ BN 1/4, CE 25 and SWK are sold separately. **(see pg. A.81).**
- UL Classified Splice.
- Slots (.22" x .28") are on .98" centers.

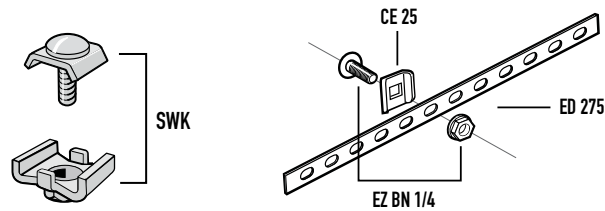

	PKG. QTY.	WEIGHT		EZ	GC	316L	BL	PE
		LBS	KG					
ED 275	50	14.4	6.5	558 221	–	558 224	941 279	930 621

CF54 – CF105 – CF150	2" (50 mm)	4" → 8" (100 → 200 mm)	12" → 24" (300 → 600 mm)
ED 275 splices needed for side wires	2x CE 25, EZ BN 1/4, ED 275	2x CE 25, EZ BN 1/4, ED 275	2x CE 25, EZ BN 1/4, ED 275
SWK splices needed on bottom of tray	–	1x SWK	2x SWK



SWK SPLICE WASHER KIT

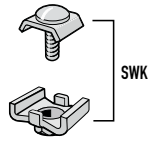

- SWK is designed with a 1/4" x 20* threaded bolt compatible with standard US tools.
- Use SWK to splice any two sections of Cablofil tray.
- Swaged nut allows clamp to be stationary while nut is tightened.
- Consult chart below for correct number of SWK sets needed for each width of tray.
- Also use for fabricating bends, turns and tees.
- UL Classified Splice.

	PKG. QTY.	WEIGHT		EZ	DC	316L	BL
		LBS	KG				
SWK	50	3.6	1.6	943 215	943 216	943 218	943 217

* Threads were previously M6

CF30 – CF54 – CF105 – CF150 – TXF35 – CFG	2" (50 mm)	4" → 8" (100 → 200 mm)	12" → 24" (300 → 600 mm)
SWK attachment sets needed for side wires	2x SWK	2x SWK	2x SWK
SWK attachment sets needed for bottom wires	–	1x SWK	2x SWK

APPLICATIONS

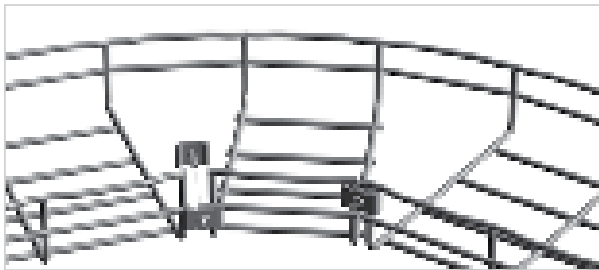

CE 40 SQUARE SPLICE WASHER

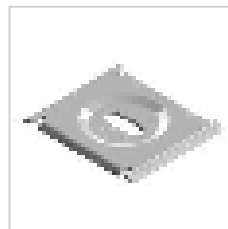

- Use for splicing Cablofil tray on bends and adjustable turns.
- Two CE 40's and one EZ BN 1/4 are required for each connection.
- EZ BN 1/4 is sold separately. (see pg. A.81).
- UL Classified Splice.

	PKG. QTY.	WEIGHT		EZ	GC	DC	316L	BL	PE
		LBS	KG						
CE 40	25	2.7	1.2	558 051	942 461	–	558 054	941 276	934 030

– Contact manufacturer for availability.

CE 25/CE 30 SQUARE SPLICE WASHER

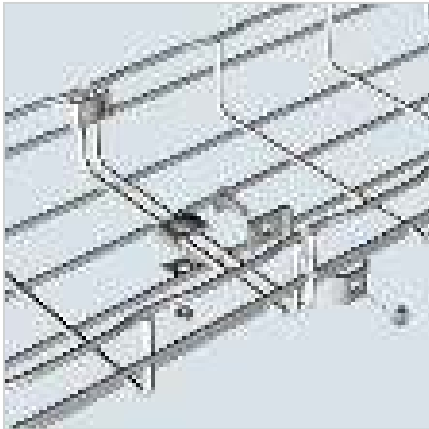

- Use CE 25 and CE 30 with EZ BN 1/4 to splice any two sections of Cablofil tray.
- Consult chart below for correct number of Nut/Bolt/Clamp sets needed for each width of tray.
- Also use for fabricating bends, turns and tees.
- UL Classified Splice.

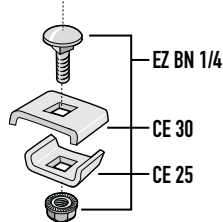

	PKG. QTY.	WEIGHT		EZ	GC	DC	316L	BL	PE
		LBS	KG						
CE 25	50	1.0	0.45	558 011	942 459	558 013	558 014	941 274	934 022
CE 30	50	1.7	0.75	558 041	942 460	558 043	558 044	941 275	934 028
EZ BN 1/4	50	1.0	0.45	941 084	–	943 458	–	942 308	942 380

– Contact manufacturer for availability.

Tray Type	2" (50 mm)	4" → 8" (100 → 200 mm)	12" → 24" (300 → 600 mm)
CF30 – CF54 – CF105 – CF150			
CE 25-CE30 attachment sets needed for side wires	2x CE 25, CE 30, EZ BN 1/4	2x CE 25, CE 30, EZ BN 1/4	2x CE 25, CE 30, EZ BN 1/4
CE 25-CE30 attachment sets needed for bottom wires	–	1x CE 25, CE 30, EZ BN 1/4	2x CE 25, CE 30, EZ BN 1/4

CE 35 CLAMPING WASHER



- Useful for clamping cable dropouts or other accessories to the top two side wires of Cablofil tray.
- Use with EZ BN 1/4 Bolt/Nut (**sold separately – see pg. A.81**).

	PKG. QTY.	LENGTH		WEIGHT		316L
		INCHES	MM	LBS	KG	
CE 35	10	1.4	35	1.1	0.5	943 249



FASLOCK SPLICE

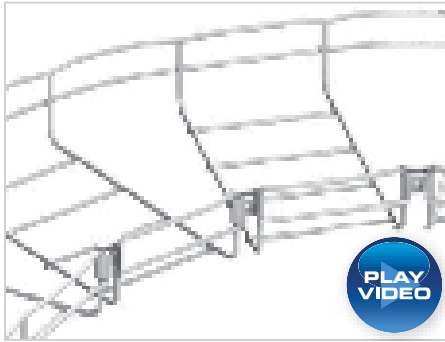

- Simple splicing method for bends and sweeps requires no tools.
- Use FASLOCK S for tray widths from 100 to 200mm and FASLOCK XL for tray widths from 300 to 600mm.
- Unique design protects installers from cut edges.

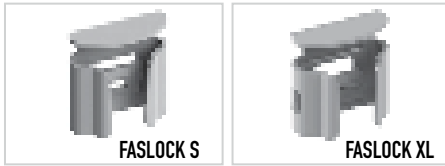
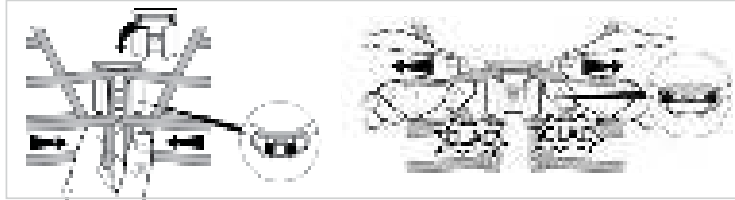

FASLOCK S

FASLOCK XL

	PKG. QTY.	WEIGHT		EZ	DC	316L	BL	PE
		LBS	KG					
FAS LOCK S	25	1.4	0.63	558 340	558 347	—	942 869	942 870
FAS LOCK XL	25	1.4	0.63	558 320	—	—	942 821	942 822

– Contact manufacturer for availability.

EAC KIT ELEVATION CHANGE HINGE

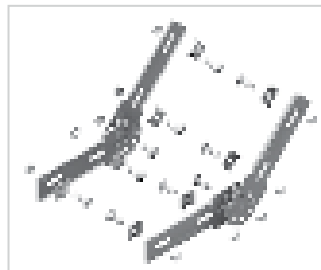

- Reinforces changes in elevation.
- Strengthens installations that support heavy power cables.
- Package contains hardware required for elevation change as shown in photo.
- Pivot hardware pre installed.
- Works with 2" through 6" depth trays.

	PKG. QTY.	WEIGHT		DC
		LBS	KG	
EAC KIT	1	0.36	0.16	943 131

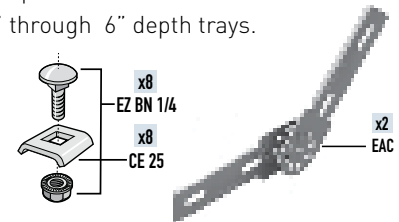

EZT 90 KIT 90° AND TEE BEND KIT

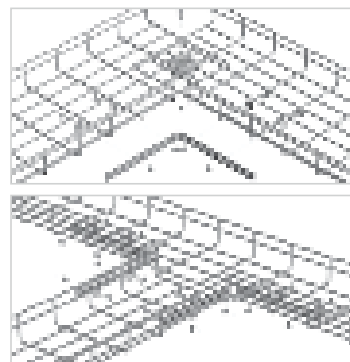

- One kit contains hardware for one tee or two 90° bends.
- Slotted Design fits any size tray and eliminates precise tray alignment.
- UL Classified Splice.

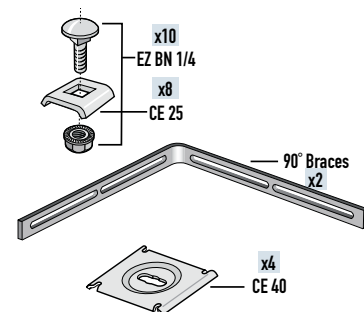

	PKG. QTY.	WEIGHT		EZ	GC	316L	BL	PE
		LBS	KG					
EZT 90 KIT	1	1.5	0.7	941 052	942 686	941 056	942 307	942 379



RADT 90 KIT

5 1/2" RADIUS TEE 90° KIT

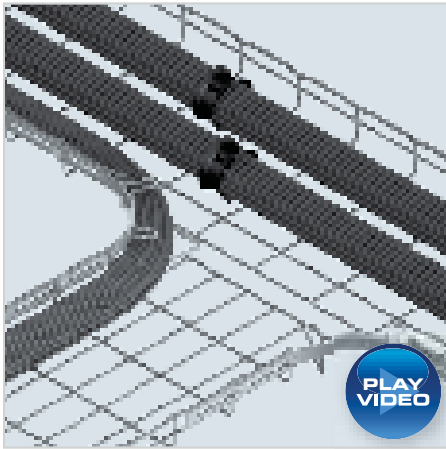

- One kit contains two Radius Splice, ten EZBN 1/4, eight CE 25 and four CE 40.
- Provides a sturdy radius tee that facilitates pulling MC or large power cables.
- Top wire loops help contain cable in tray while being pulled.
- One kit contains hardware for one tee or two 90° bends.
- UL Classified Splice.
- Patented design.



x2
RADIUS
SPLICE

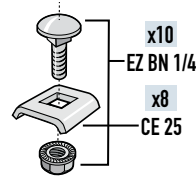

x10
EZ BN 1/4
x8
CE 25

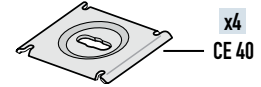

x4
CE 40

	PKG. QTY.	HEIGHT		WEIGHT		EZ	GC	BL*	PE
		INCHES	MM	LBS	KG				
RAD T 90 KIT 2	1	2.0	54	2.0	0.90	942 911	943 209	943 027	943 121
RAD T 90 KIT 4	1	4.0	105	2.2	0.99	942 912	943 157	943 108	943 403
RAD T 90 KIT 6	1	6.0	150	2.4	1.08	942 942	943 160	943 387	944 411

* Other painted finishes available. Please contact Legrand Customer Service.

RADT 9012 KIT

12" RADIUS TEE 90° KIT

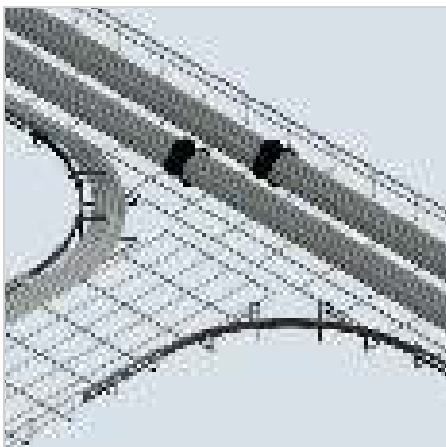

- One kit contains two Radius T 90 12 Splice, ten EZ BN 1/4, eight CE 25 and four CE 40.
- Provides a sturdy radius tee that facilitates pulling MC or large power cables.
- Top wire loops help contain cable in tray while being pulled.
- One kit contains hardware for one tee or two 90° bends.
- UL Classified Splice.
- Patented design.

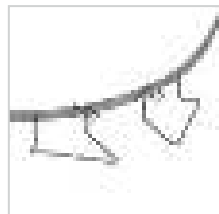

x2
RADIUS
SPLICE

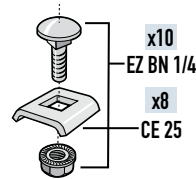

x10
EZ BN 1/4
x8
CE 25

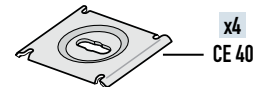

x4
CE 40

	PKG. QTY.	HEIGHT		WEIGHT		EZ	GC	BL	PE
		INCHES	MM	LBS	KG				
RAD T 90 12 KIT 2	1	2.0	54	3.2	1.45	943 474	—	943 475	943 476
RAD T 90 12 KIT 4	1	4.0	105	3.6	1.63	943 478	943 481	943 479	943 480
RAD T 90 12 KIT 6	1	6.0	150	3.8	1.72	943 482	—	943 483	943 484

– Contact manufacturer for availability.



WALL MOUNTINGS



- A.29 FAS P**
FAS PROFILE
- A.29 FV**
VERTICAL BRACKET
- A.30 FAS L**
BRACKET
- A.30 WTSB**
WALL TOP SADDLE BRACKET
- A.31 FAS C**
BRACKET
- A.32 FAS U**
UNIVERSAL BRACKET
- A.33 EDF**
RAIL
- A.34 CS**
STANDARD L BRACKET
- A.34 CSC**
STANDARD C BRACKET
- A.35 CRP**
UNIVERSAL WALL BRACKET
- A.35 C 50**
WALL MOUNT ATTACHMENT
- A.36 UC 50**
CABLE TRAY STANDOFF
- A.37 CAT 30/41**
SNAP-IN WALL
HANGER SUPPORT

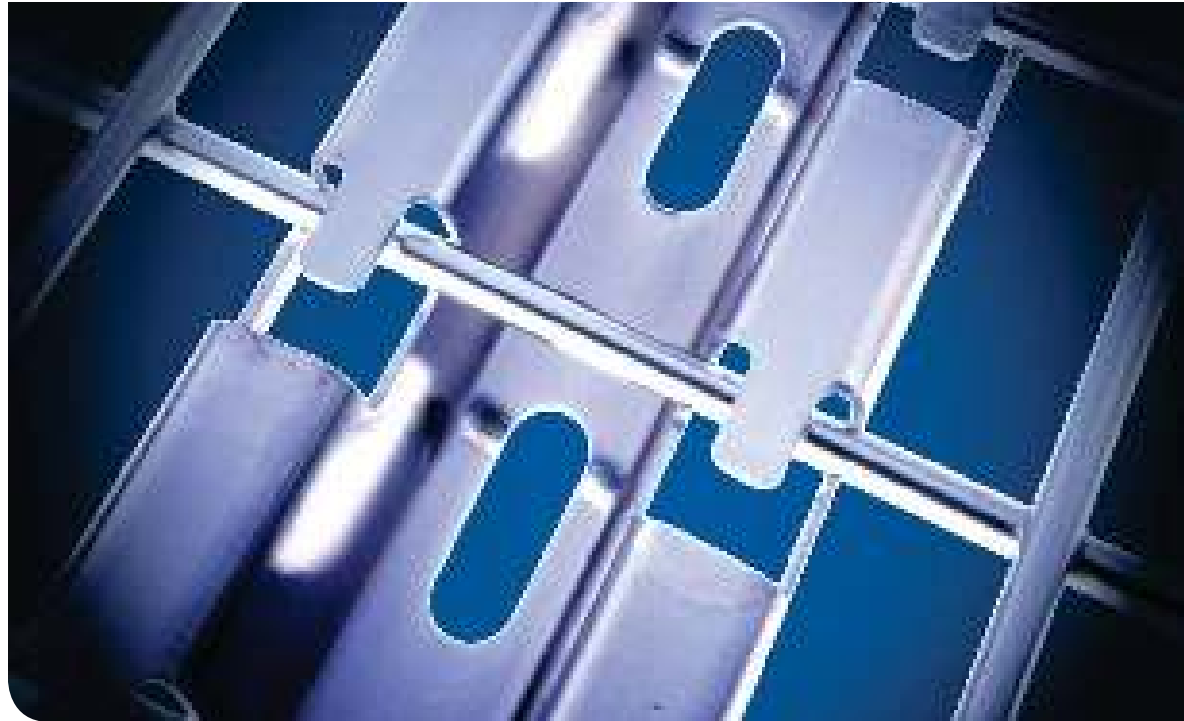

Many Cablofil wall supports utilize our unique Fast Assembly System (FAS). This system utilizes simple one-step locking tabs that require no additional hardware to secure tray runs to its supports, reducing installation time and saving money. Also available are standard wall supports that require bolted connections to the tray. This comprehensive range of wall supports in multiple finishes allows for every possible installation you will need.



FAS P FAS PROFILE

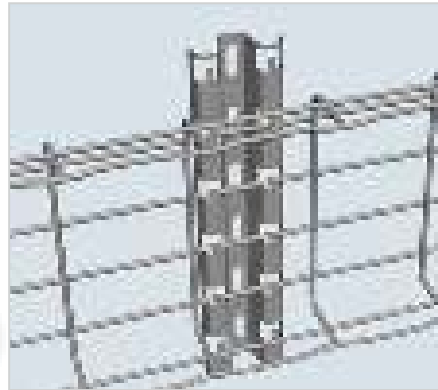

- Pre-drilled mounting holes make installations easy.
- Patented FAS style attachment secures tray without nuts and bolts.
- Will hold tray away from wall 0.66".

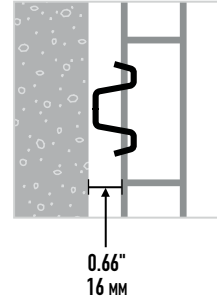

	LENGTH		WEIGHT		PG	GC	316L	BL	PE
	INCHES	MM	LBS	KG					
FASP 150	6.0	150	0.4	0.2	014 150	014 153	014 154	941 153	930 012
FASP 200	8.0	200	0.7	0.3	014 200	014 203	014 204	941 154	930 014
FASP 300	12.0	300	0.9	0.4	014 300	014 303	014 304	941 155	930 016
FASP 400	16.0	400	1.1	0.5	014 400	014 403	014 404	941 156	930 018
FASP 450	18.0	450	1.2	0.6	014 450	–	–	941 157	930 020
FASP 500	20.0	500	1.3	0.6	014 500	–	–	941 158	930 022
FASP 550	22.0	550	1.3	0.6	014 550	014 553	–	941 159	930 024
FASP 600	24.0	600	1.5	0.7	014 600	014 603	014 604	941 160	930 026
FASP 700	28.0	700	1.8	0.8	014 700	–	014 704	941 162	930 028
FASP 1000	40.0	1000	2.6	1.2	014 010	–	014 014	941 149	930 006
FASP 2000	80.0	2000	5.3	2.4	014 020	–	–	941 151	930 008
FASP 3000	120.0	3000	7.9	3.6	014 030	014 033	014 034	941 152	930 010

– Contact manufacturer for availability.

FV VERTICAL BRACKET

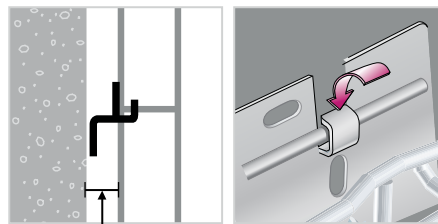

1.18"
30 MM

- Unique support keeps tray secure vertically.
- Fold-over tabs secure tray; no additional hardware needed.
- Uses 2 supports for tray widths of 18" or more.
- Use on 6" and wider tray.

	LENGTH		WEIGHT		PG	GC	316L	BL	PE
	INCHES	MM	LBS	KG					
FV 1	8.0	200	0.7	0.3	586 070	586 073	586 074	942 805	–

– Contact manufacturer for availability.



**FAS L
BRACKET**

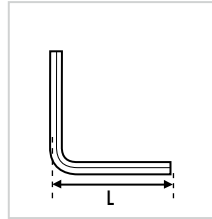
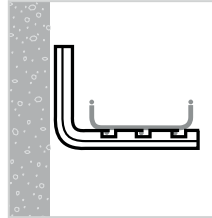

- For installation of Cablofil tray onto walls.
- Reduce installation time—patented FAS style attachment holds tray secure without nuts and bolts.
- Order “width” to match tray.

	TRAY WIDTH		LENGTH (L)		WEIGHT		PG	GC	304L	316L	BL	PE
	INCHES	MM	INCHES	MM	LBS	KG						
FASL 100	4.0	100	7.0	178.5	0.9	0.4	556 100	556 103	—	556 104	941 257	930 523
FASL 150	6.0	150	9.0	228.5	1.0	0.5	556 110	556 113	—	556 114	941 258	930 525
FASL 200	8.0	200	11.0	278.5	1.1	0.5	556 120	556 123	—	556 124	941 259	930 527
FASL 300	12.0	300	14.9	378.5	1.4	0.6	556 130	556 133	—	556 134	941 260	930 529
FASL 400	16.0	400	18.8	478.5	1.8	0.8	556 140	—	—	—	943 146	943 388
FASL 450	18.0	450	20.8	528.5	2.1	1.0	556 150	—	—	—	942 848	942 600

– Contact manufacturer for availability.

**WTSB
WALL TOP SADDLE BRACKET**

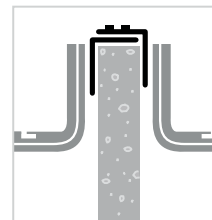
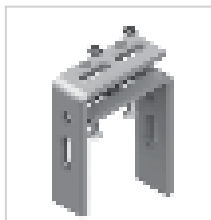
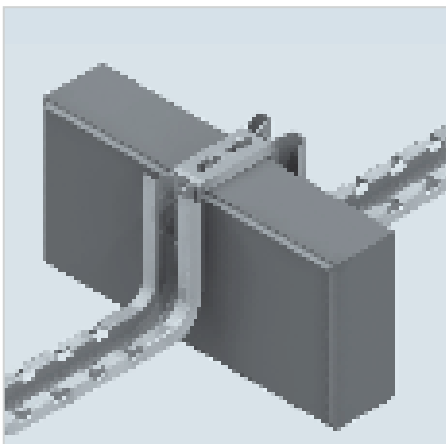

- Installs Cablofil tray onto interior block walls without drilling or concrete anchors.
- Includes two EZBN 5/16 bolts to attach FAS L or FAS C tray supports (**sold separately – see pg. A.81**).

	PKG QTY	WIDTH		WEIGHT		EZ
		INCHES	MM	LBS	KG	
WTSB 46	10	4.0-6.0	102-152	1.9	0.86	943 347
WTSB 810	10	8.0-10.0	203-254	2.3	1.05	943 348

Patent Number – 20090289152

WALL MOUNTINGS

FAS C BRACKET

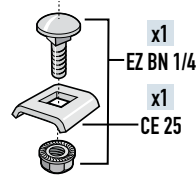
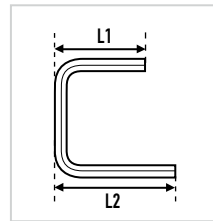
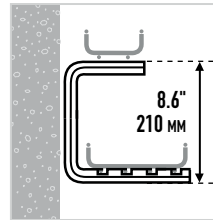

- Use one or more FAS C brackets to create multiple level tray installations.
- Saves installation time – patented FAS style attachment holds tray secure without nuts and bolts.
- EZ BN 1/4 and CE 25 are sold separately. **(see pg. A.81).**

	TRAY WIDTH		LENGTH (L1)		LENGTH (L2)		WEIGHT		PG	GC	304L	316L	BL	PE
	INCHES	MM	INCHES	MM	INCHES	MM	LBS	KG						
FASC 100	4.0	100	6.7	170	7.0	178.5	1.4	0.6	556 300	–	–	–	941 261	930 531
FASC 150	6.0	150	6.7	170	8.9	228.5	1.5	0.7	556 310	–	–	–	941 262	930 533
FASC 200	8.0	200	6.7	170	10.9	278.5	1.7	0.8	556 320	–	–	–	941 263	930 535
FASC 300	12.0	300	11.3	288	14.9	378.5	1.9	0.9	556 330	–	–	–	941 264	930 537
FASC 400	16.0	400	11.3	288	18.8	478.5	2.4	1.1	556 340	–	–	–	943 096	–
FASC 450	18.0	450	11.3	288	20.8	528.5	2.75	1.25	556 350	–	–	–	942 596	–

– Contact manufacturer for availability.

APPLICATIONS

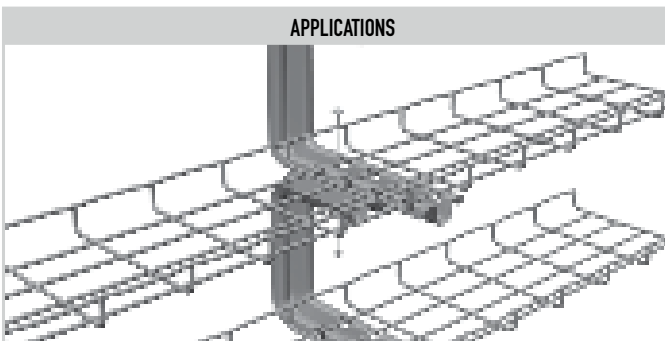

**FAS U
UNIVERSAL BRACKET**

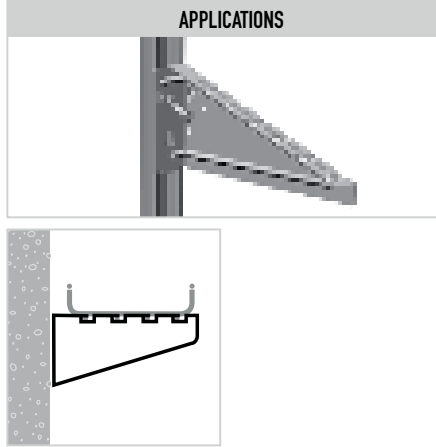

- For tray installation onto walls or channel framing.
- Patented FAS style attachment holds tray secure without nuts and bolts.

	HEIGHT		TRAY WIDTH		LENGTH		WEIGHT		PG	GC	316L	BL	PE
	INCHES	MM	INCHES	MM	INCHES	MM	LBS	KG					
FASU 100	3.5	85	4.0	100	6.0	157	0.3	0.1	557 410	–	557 414	941 267	930 575
FASU 150	5.0	124	6.0	150	8.0	207	0.4	0.2	557 420	557 423	557 424	941 268	930 577
FASU 200	5.5	139	8.0	200	12.0	257	0.5	0.2	557 430	557 433	557 434	941 269	930 579
FASU 300	5.5	139	12.0	300	14.0	357	0.8	0.3	557 440	557 443	557 444	941 270	930 581

– Contact manufacturer for availability.

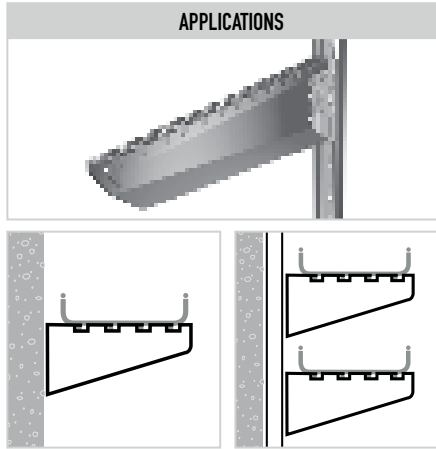
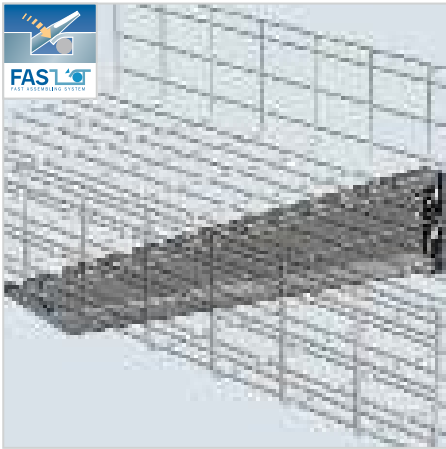

- For wider tray and heavier loads.
- Snaps directly into EDF rail.

	HEIGHT		TRAY WIDTH		LENGTH		WEIGHT		PG	GC	316L	BL	PE
	INCHES	MM	INCHES	MM	INCHES	MM	LBS	KG					
FASU 400	5.5	137.7	16.0	400	18.0	457	1.8	0.8	557 450	557 453	557 454	941 271	930 583
FASU 450	5.5	137.7	18.0	450	20.0	507	2.4	1.1	944 533	–	–	944 536	944 937
FASU 500	5.5	137.7	20.0	500	22.0	557	2.9	1.3	557 460	557 463	–	941 272	930 585
FASU 600	5.5	137.7	24.0	600	26.0	657	6.4	2.9	557 470	–	–	941 273	930 587

– Contact manufacturer for availability.

WALL MOUNTINGS



EDF RAIL

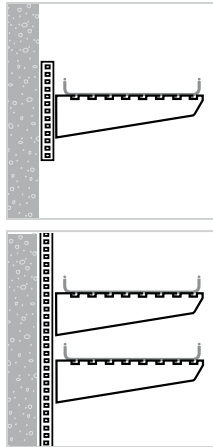

- EDF Rail makes tiered tray runs easier and faster to install.
- CA Pin (sold separately) is required to install 4" to 12" FASU. Suggested for 16" to 24" FASU.
- FASU sizes 16" to 24" will snap directly onto EDF Rail.

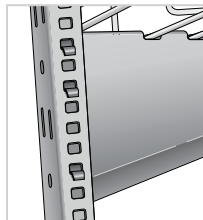
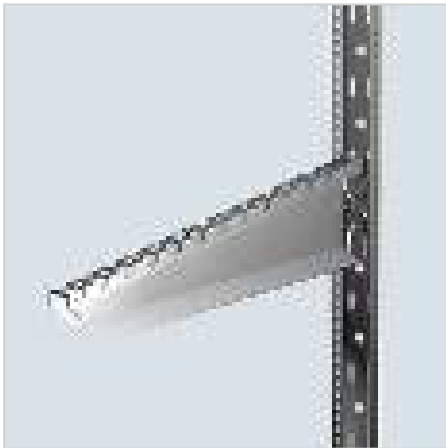
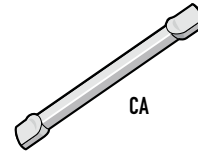

	LENGTH		WEIGHT		PG	GC	316L	BL	PE
	INCHES	MM	LBS	KG					
EDF 300	10.6	270	0.7	0.3	561 310	561 313	–	942 817	942 818
EDF 600	24.8	630	1.8	0.8	557 610	557 613	–	942 815	942 816
EDF 1000	39.0	990	2.6	1.2	561 090	561 093	–	942 813	942 814
EDF 2000	78.0	2000	5.5	2.5	561 010	561 013	–	941 288	930 641
EDF 3000	120.0	3000	9.1	4.1	561 020	561 023	–	941 289	930 643

– Contact manufacturer for availability.



CS
STANDARD L BRACKET

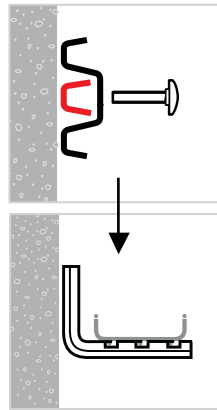
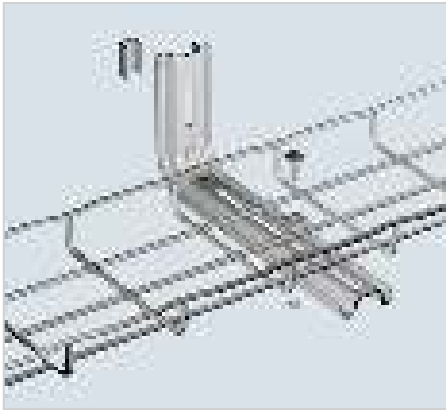

- For cable tray installation onto walls.
- ECLI clip prevents bracket compression.
- EZ BN 1/4, CE 25 and ECLI are sold separately. **(see pg. A.81).**

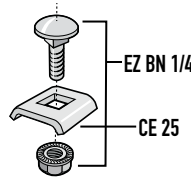

100 – 200 MM x1
300 – 450 MM x2



	WIDTH		LENGTH		WEIGHT		PG	GC	316L	BL	PE
	INCHES	MM	INCHES	MM	LBS	KG					
CS 100	4.0	100	5.7	145	0.4	0.2	002 700	–	002 704	941 130	930 070
CS 200	8.0	200	9.6	245	0.8	0.4	002 710	002 713	–	941 131	930 072
CS 300	12.0	300	13.6	345	1.2	0.5	002 720	–	002 724	941 132	930 074

– Contact manufacturer for availability.

CSC
STANDARD C BRACKET

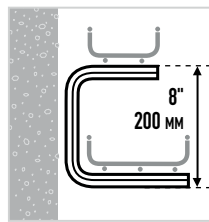
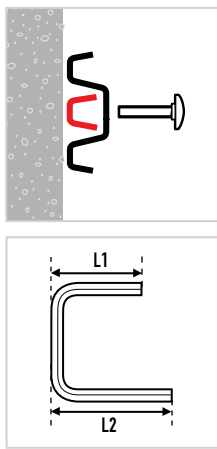
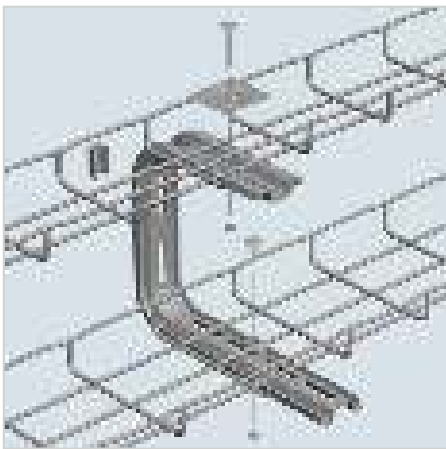

- Can be stacked for multilevel Cablofil tray installations.
- ECLI clip prevents bracket compression.
- EZ BN 1/4, EZ BN 5/16, CE 25, CE 40 and ECLI are sold separately. **(see pg. A.81).**

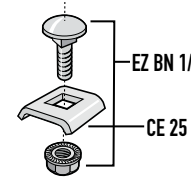

100 – 200 MM x1
300 MM x2

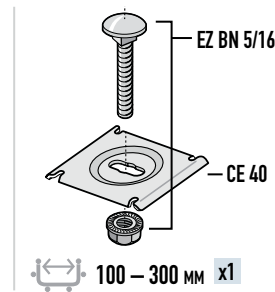

	WIDTH		LENGTH (L1)		LENGTH (L2)		WEIGHT		PG	GC	316L	BL	PE
	INCHES	MM	INCHES	MM	INCHES	MM	LBS	KG					
CSC 100	4.0	100	5.1	130	5.7	145	1.1	0.5	002 760	–	–	941 136	930 082
CSC 200	8.0	200	7.0	180	9.6	245	1.4	0.7	002 770	–	002 774	941 137	930 084
CSC 300	12.0	300	9.0	230	13.6	345	1.8	0.8	002 780	–	–	941 138	930 086

– Contact manufacturer for availability.



CRP UNIVERSAL WALL BRACKET

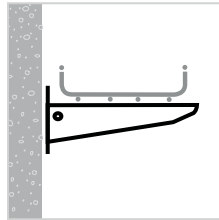

- Hot dipped galvanized after fabrication for corrosion resistance.
- CE 25 and EZ BN 1/4 are sold separately. **(see pg. A.81).**

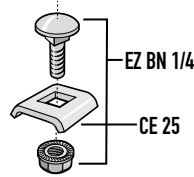

- 100 – 200 MM x1
- 300 – 400 MM x2
- 500 – 600 MM x3

	HEIGHT		WIDTH		LENGTH		WEIGHT		GC
	INCHES	MM	INCHES	MM	INCHES	MM	LBS	KG	
CRP 100	3.7	93	4.0	100	4.6	117	0.4	0.2	–
CRP 150	3.7	93	6.0	150	6.5	167	0.7	0.3	–
CRP 200	3.7	93	8.0	200	8.5	217	0.8	0.3	557 233
CRP 300	3.7	93	12.0	300	12.4	317	1.0	0.5	557 243
CRP 400	4.7	121	16.0	400	16.4	417	1.3	0.6	–
CRP 500	4.7	121	20.0	500	20.4	517	1.8	0.8	557 263
CRP 600	4.7	121	24.0	600	24.3	617	2.4	1.1	557 273

– Contact manufacturer for availability.

C 50 WALL MOUNT ATTACHMENT

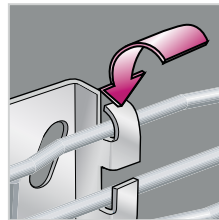

- Attaches tray up to 4" wide to walls, cabinets or machinery.
- Fold-over tabs secures tray without additional hardware.
- Slotted mounting holes make for adjustable installations.

	WEIGHT		PG	GC	316L	BL	PE
	LBS	KG					
C 50	0.2	0.1	586 130	586 133	–	941 308	930 694

– Contact manufacturer for availability.

APPLICATIONS

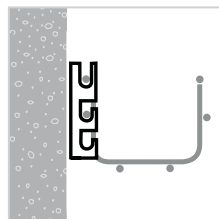
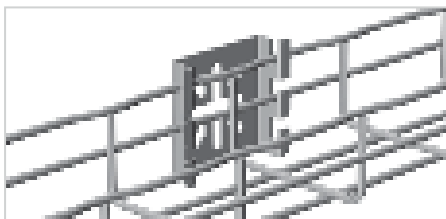

- Secure tray in open front configuration.

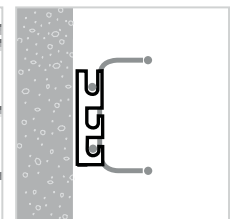
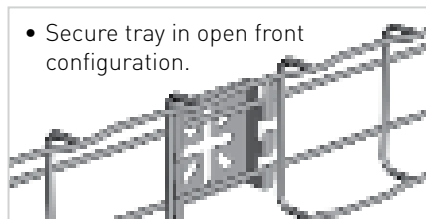

UC 50
CABLE TRAY STANDOFF

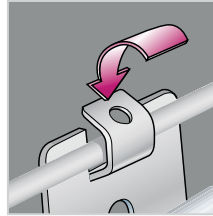
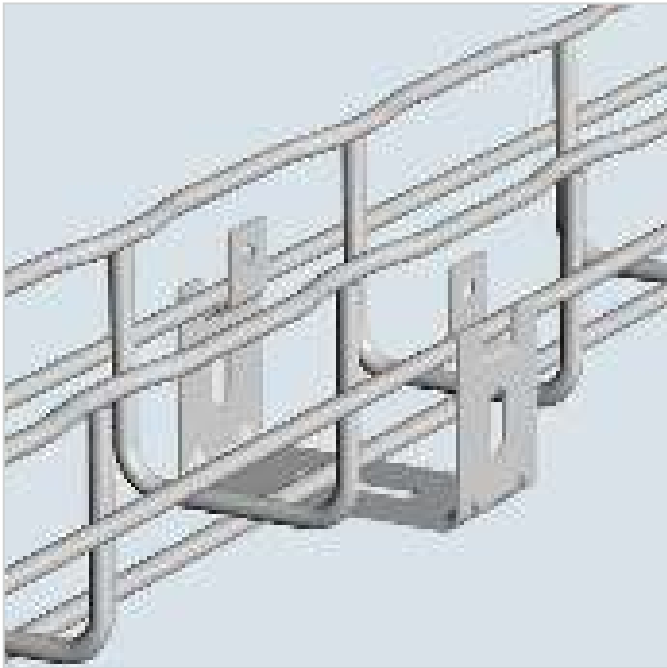

- Attaches 2" wide tray to cabinet tops and channel framing.
- Fold over tabs secure tray without fasteners.

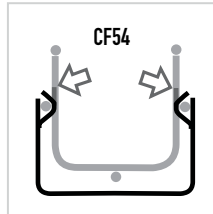
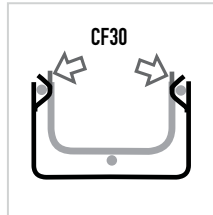

	WEIGHT		PG	GC	316L	BL	PE
	LBS	KG					
UC 50	0.1	0.06	586 040	586 043	586 044	941 304	930 681

APPLICATIONS

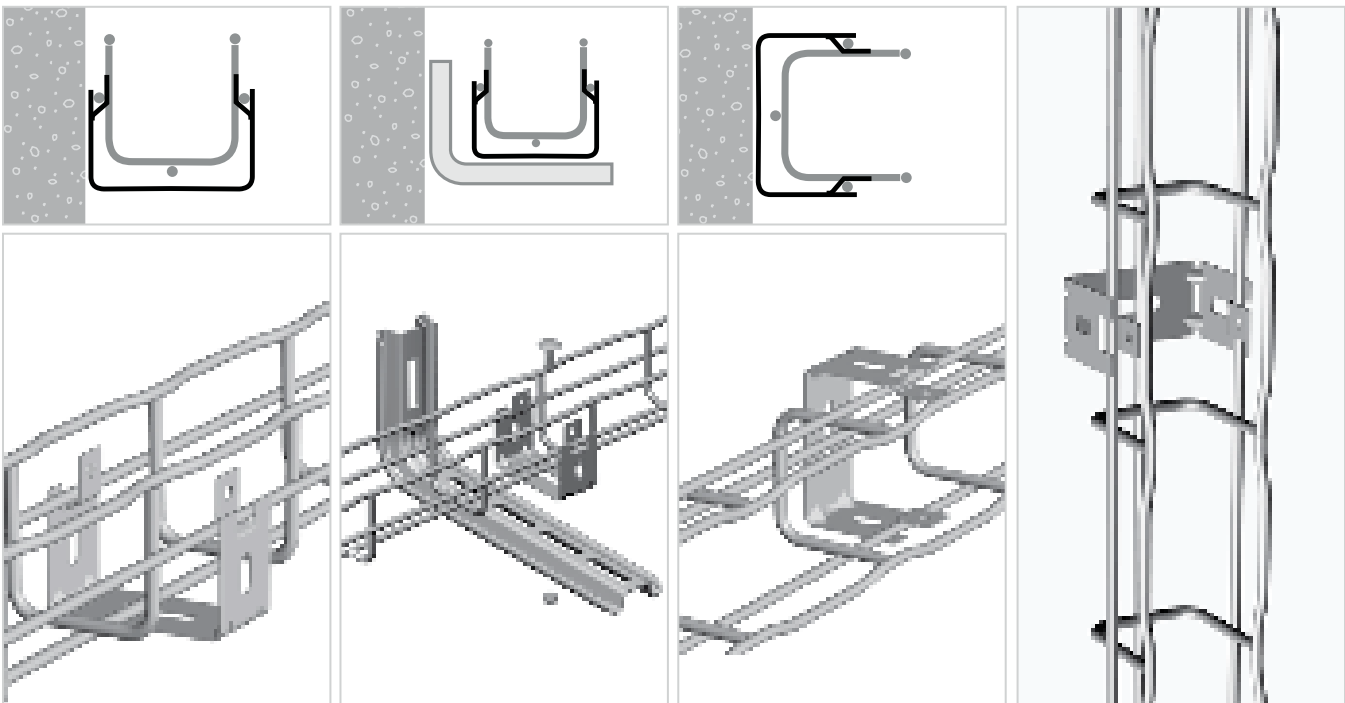

Attaches 2" wide tray to CS wall supports.

Can attach 2" wide tray directly to wall for horizontal and vertical installations.

CAT 30/41
SNAP-IN WALL HANGER SUPPORT

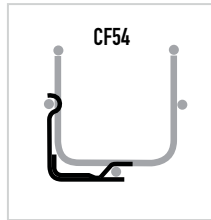
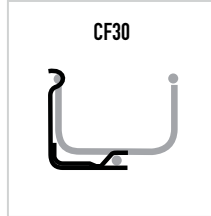
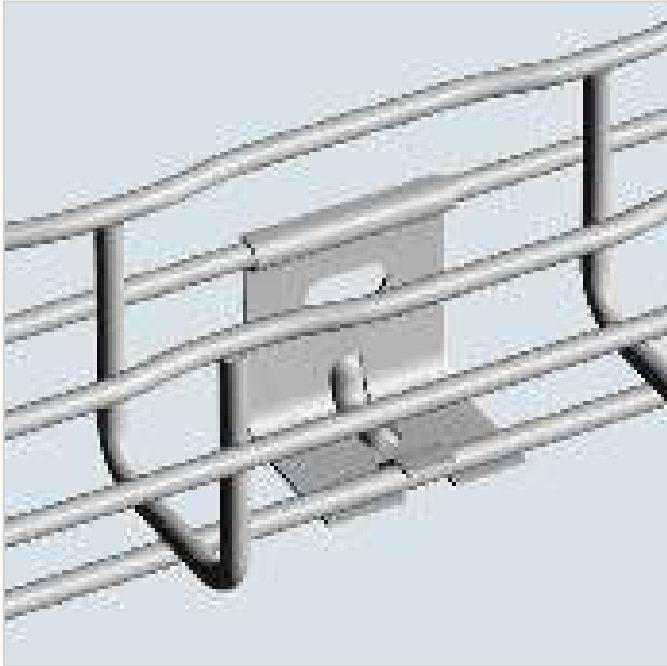

- Keeps 2" wide tray secure when attaching to supports.
- No screws required for tray attachment.
- Just snap in place.

	WEIGHT		PG	GC	316L	BL	PE
	LBS	KG					
CAT 30/41	0.1	0.03	942 720	-	-	942 800	942 801

- Contact manufacturer for availability.

APPLICATIONS

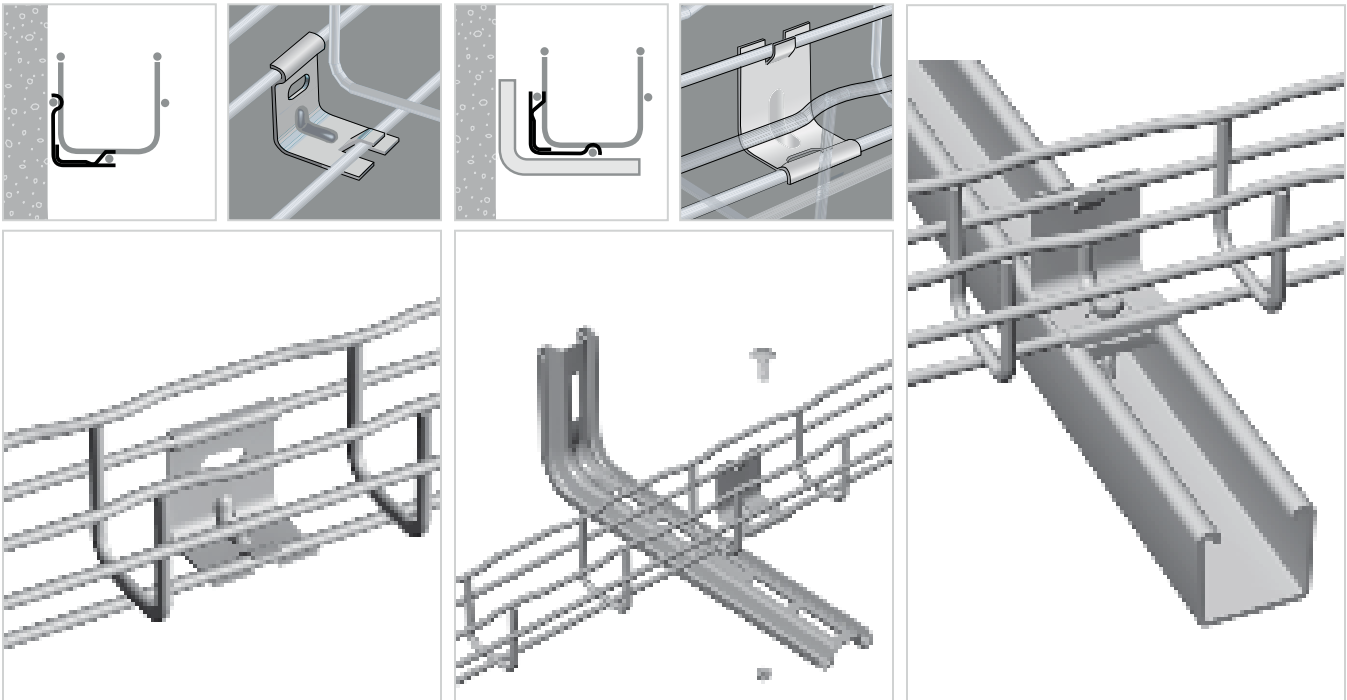

CAT 30/41 can attach 2" wide tray directly to walls, cabinets or machinery.

Use EZ BN 1/4 to attach 2" wide tray to channel framing or CS supports.



CEILING MOUNTINGS



- A.39 SF 50**
CENTER HANGER
- A.39 SF 100**
CENTER HANGER
- A.40 PAT 30**
SUSPENSION SHOE
- A.40 SAS**
SINGLE HANGER
SUSPENSION BRACKET
- A.41 FAS PCH**
CENTER HANGER
- A.42 FAS P**
FAS PROFILE
- A.42 SON**
SLIP-ON LOCK NUT®
- A.43 AS**
TRAPEZE HANGING CLIP
- A.43 PROCS**
STANDARD PROFILE
- A.44 FAS C**
BRACKET
- A.44 CSC**
STANDARD C BRACKET
- A.45 CS / PS**
PENDANT L BRACKETS
- A.46 EDF**
RAIL
- A.47 PFREDF**
MOUNTING BRACKET
- A.47 DF**
ANGLE MOUNTING BRACKET
- A.47 ERD 10**
BRACE PLATE

Legrand offers three styles of Cablofil ceiling hung supports, direct attachment to the ceiling deck, suspended from threaded rods or pendant style supports. Many hangers feature our unique FAS system of securing the tray to the supports without additional hardware. All Cablofil ceiling supports are available in a variety of finishes to compliment the type of tray you plan to install.

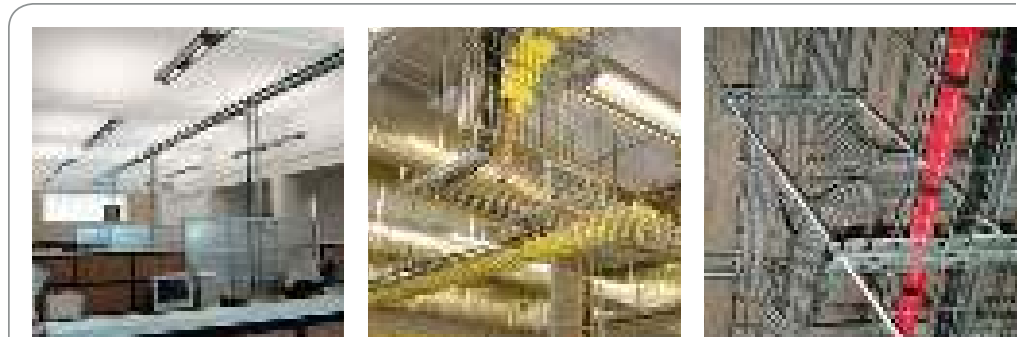

SF 50 CENTER HANGER

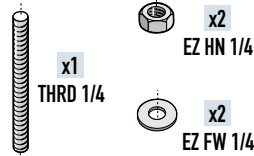
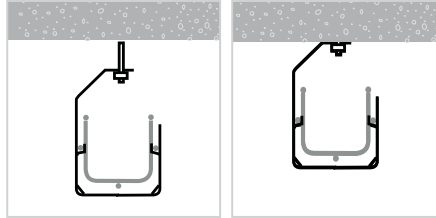

- For center hanging 2" wide tray.
- Fold-over tabs secure tray without additional hardware.
- Threaded rod, nuts and washers sold separately.
- Optional THRD: 5/16"
- Can be attached directly to ceiling with power tools thru bottom access hole.

	WIDTH		WEIGHT		PG	GC	316L	BL	PE
	INCHES	CM	LBS	KG					
SF 50	2.0	50	0.4	0.2	586 140	586 143	586 144	942 593	942 594

SF 100 CENTER HANGER

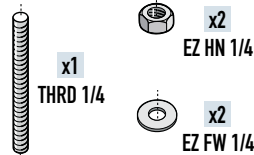
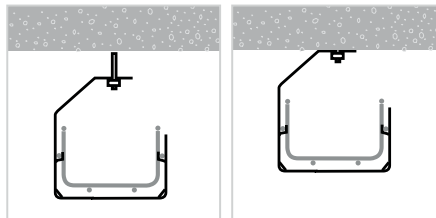
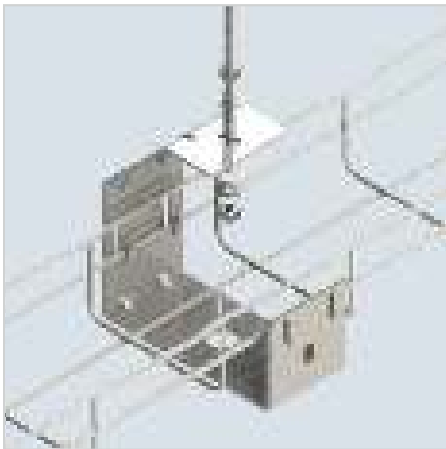

- For center hanging 4" wide tray.
- Fold-over tabs secure tray without additional hardware.
- Threaded rod, nuts and washers sold separately.
- Optional THRD: 5/16"
- Can be attached directly to ceiling with power tools thru bottom access hole.

	WIDTH		WEIGHT		PG	GC	316L	BL	PE
	INCHES	CM	LBS	KG					
SF 100	4.0	100	0.9	0.4	586 100	586 103	586 104	942 840	942 606



PAT 30
SUSPENSION SHOE

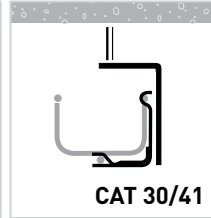
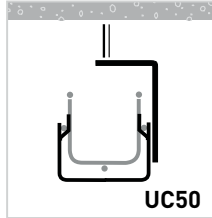
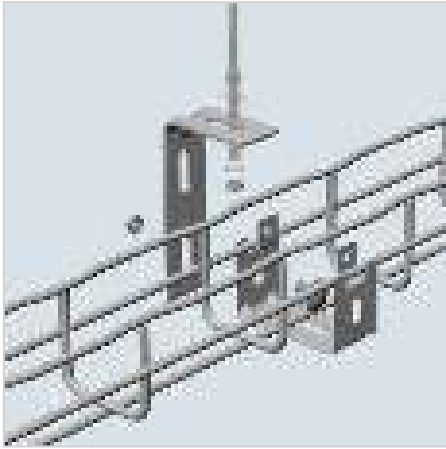

- Works with CAT 30/41 and UC 50 for trapeze hanging 2" wide tray.
- Use EZ BN 1/4 and CAT 30/41 for attachment (sold separately).
- Threaded rod, nuts and washers sold separately.

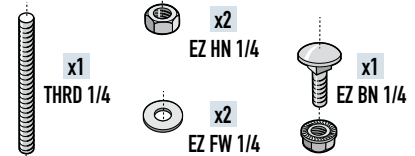

	WEIGHT		PG	GC	316L	BL	PE
	LBS	KG					
PAT 30	0.2	0.1	557 300	557 303	557 304	941 265	930 569

SAS
SINGLE HANGER SUSPENSION BRACKET

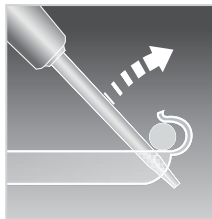
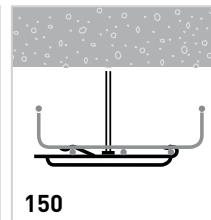
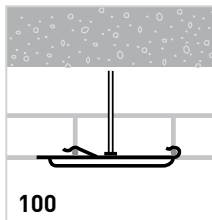
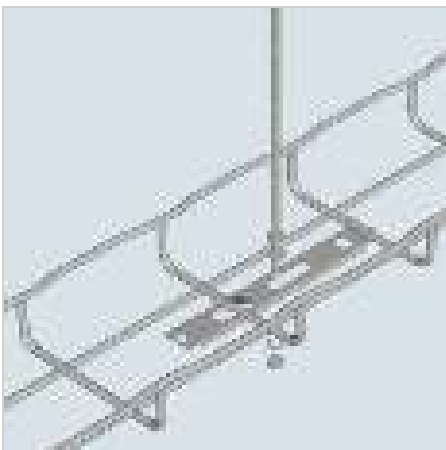

- Snap in attachment requires no bolts, nuts, or tools to attach Cablofil tray.
- Threaded rod, nuts and washers sold separately.
- Limit to 6" or smaller tray

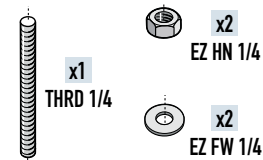

	PKG. QTY.	WEIGHT		EZ	DC	BL	PE
		LBS	KG				
SAS	50	3.3	1.5	586 031	586 037	941 303	930 679



FAS PCH CENTER HANGER

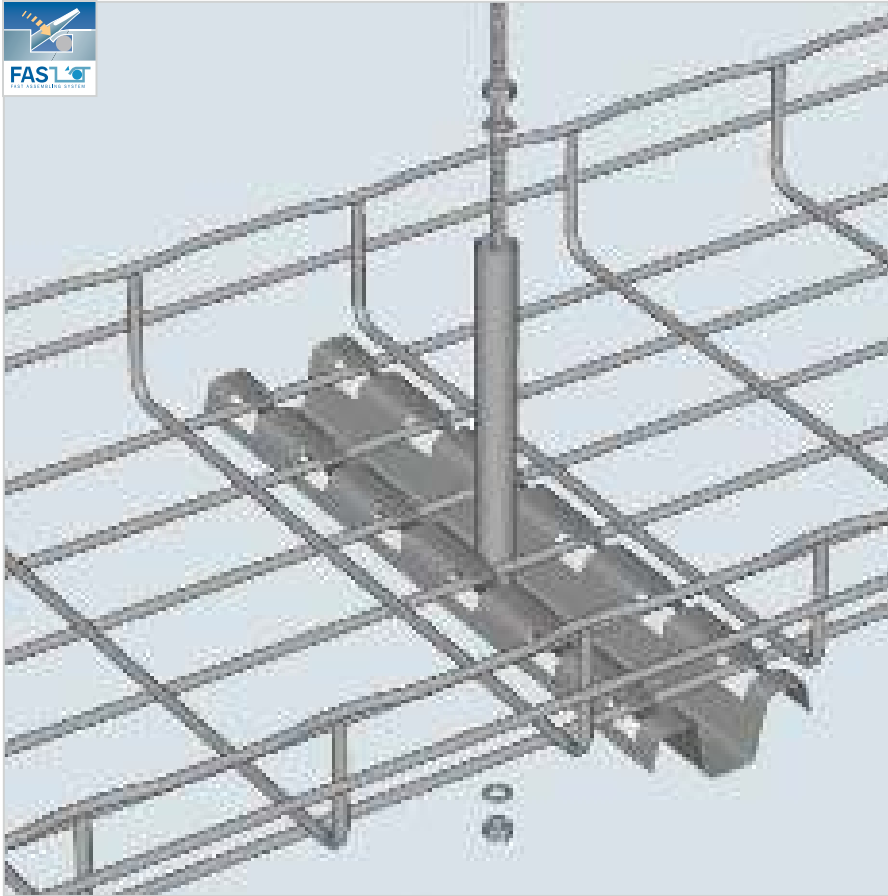

- Only one threaded rod is needed to suspend tray.
- Suspension tube protects cables.
- 6" and 18" Center Hangers have offset suspension tube to avoid center wire.
- Threaded rod, nuts and washers sold separately.
- Balanced loading recommended.

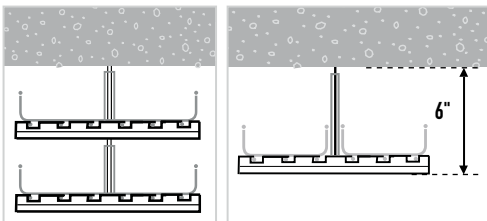
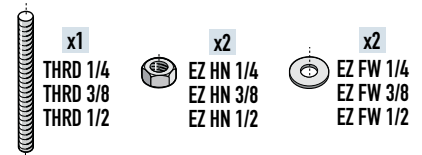

	LENGTH		WEIGHT		PG	GC	316L	BL	PE
	INCHES	MM	LBS	KG					
FASPCH 150	6.0	144	0.6	0.2	942 357	–	–	942 315	942 387
FASPCH 200	8.0	194	0.7	0.3	586 200	–	–	941 310	934 049
FASPCH 300	12.0	294	0.9	0.4	586 300	–	–	941 311	934 050
FASPCH 400	16.0	394	1.1	0.5	586 400	–	–	941 312	934 051
FASPCH 450	18.0	444	1.3	0.6	586 450	–	–	941 313	934 052
FASPCH 500*	20.0	494	1.3	0.6	586 500	–	–	941 314	934 053
FASPCH 600*	24.0	594	1.5	0.7	586 600	–	–	941 315	934 054

– Contact manufacturer for availability.
*1/2 threaded rod required for this size hanger.



FAS P FAS PROFILE

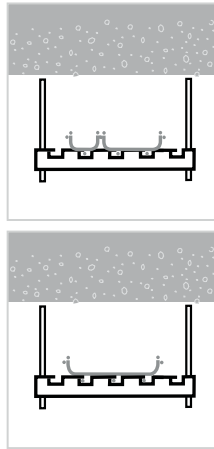

- For trapeze hung installations, use 4" longer profile than tray width. Example: for CF 54/300 tray (12") use FAS P400 (16").
- Maximum threaded rod size is 3/8". For use with larger sizes of threaded rod, bracket holes must be drilled larger.
- Patented FAS style attachment secures tray without nuts and bolts.
- Threaded rods, nuts and washers sold separately.
- Notify Customer Service when placing order.

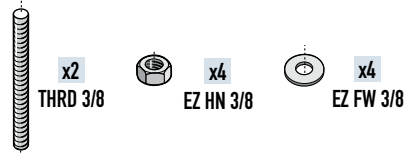

	TRAY WIDTH		LENGTH		WEIGHT		PG	GC	316L	BL	PE
	INCHES	MM	INCHES	MM	LBS	KG					
FASP 150	2.0	50	6.0	150	0.4	0.2	014 150	014 153	014 154	941 153	930 012
FASP 200	4.0	100	8.0	200	0.7	0.3	014 200	014 203	014 204	941 154	930 014
FASP 300	Multiple		12.0	300	0.9	0.4	014 300	014 303	014 304	941 155	930 016
FASP 400	12.0	300	16.0	400	1.1	0.5	014 400	014 403	014 404	941 156	930 018
FASP 450	14.0	350	18.0	450	1.2	0.5	014 450	–	–	941 157	930 020
FASP 500	16.0	400	20.0	500	1.3	0.6	014 500	–	–	941 158	930 022
FASP 550	18.0	450	22.0	550	1.3	0.6	014 550	014 553	–	941 159	930 024
FASP 600	20.0	500	24.0	600	1.5	0.7	014 600	014 603	014 604	941 160	930 026
FASP 700	24.0	600	28.0	700	1.8	0.8	014 700	–	014 704	941 162	930 028
FASP 1000	Multiple		40.0	1000	2.6	1.2	014 010	–	014 014	941 149	930 006
FASP 2000	Multiple		80.0	2000	5.3	2.4	014 020	–	–	941 151	930 008
FASP 3000	Multiple		120.0	3000	7.9	3.6	014 030	014 033	014 034	941 152	930 010

– Contact manufacturer for availability.

SON SLIP-ON LOCK NUT®

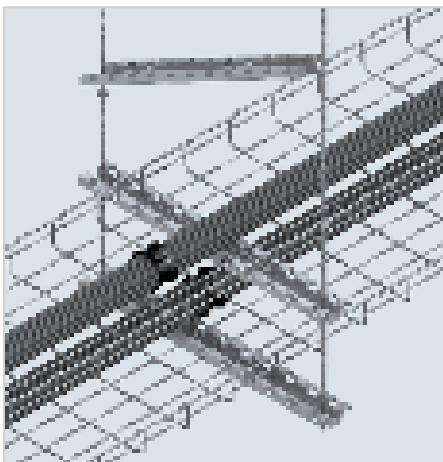

- Install additional tiers to existing trapeze hung cable pathways with ease.
- To install, place slip-on nut onto threaded rod, rotate nut halves, tighten halves to lock in place.
- FASP end slots require being "opened up" to install on threaded rod(s).

	PKG QTY	THREAD SIZE	EZ	304L
SON1/4	2	1/4 - 20	943 351	–
SON3/8	2	3/8 - 18	943 352	–
SON1/2	2	1/2 - 12	943 353	–
SON5/8	2	5/8 - 11	943 354	–

– Contact manufacturer for availability.



AS TRAPEZE HANGING CLIP

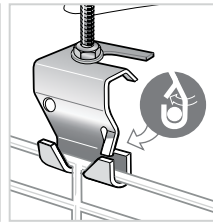
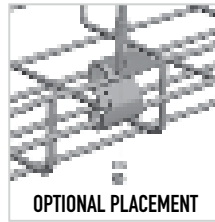
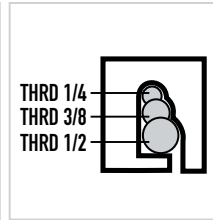
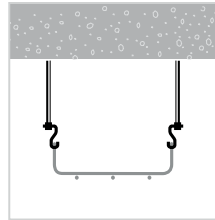

- Tray can be detached on one side to add cables.
- Use pliers to lock tabs and secure tray to threaded rod.
- Threaded rods, nuts, and washers sold separately.
- Allows threaded rod to extend past AS clip for multi-tier levels.

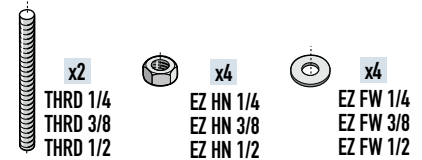

	PKG. QTY.	WEIGHT		PG	GC	316L	BL	PE
		LBS	KG					
AS	50	6.6	3.0	586 020	—	586 024	941 301	930 675

– Contact manufacturer for availability.

PROCS STANDARD PROFILE

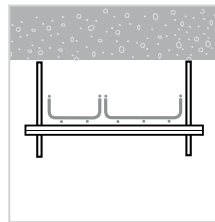

- Field cut to any length.
- Can support multiple tray runs.
- Threaded rods, nuts, and washers sold separately.

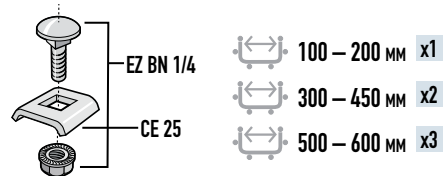
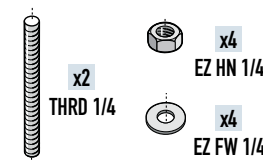

	LENGTH		WEIGHT		PG	GC	316L	BL	PE
	INCHES	MM	LBS	KG					
PROCS 1000	39.0	1000	2.6	1.2	002 920	—	002 924	941 140	930 088
PROCS 2000	79.0	2000	5.1	2.3	002 930	—	—	941 141	930 090
PROCS 3000	118.0	3000	8.4	3.8	002 940	—	—	941 142	930 092

– Contact manufacturer for availability.



FAS C BRACKET



- For cable tray installation under ceilings or overhangs.
- Can be stacked for multiple levels of tray.
- Saves installation time—patented FAS style attachment holds cable tray secure without nuts and bolts.
- EZ BN 1/4 and CE 25 are sold separately. **(see pg. A.81).**

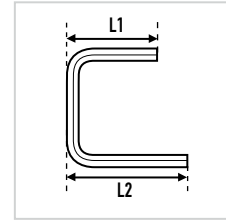
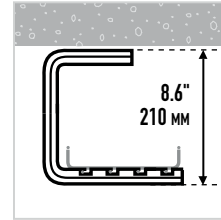

	WIDTH		LENGTH (L1)		LENGTH (L2)		WEIGHT		PG	GC	316L	BL	PE
	INCHES	MM	INCHES	MM	INCHES	MM	LBS	KG					
FASC 100	4.0	100	6.7	170	7.0	178.5	1.4	0.6	556 300	—	556 304	941 261	930 531
FASC 150	6.0	150	6.7	170	8.9	228.5	1.5	0.7	556 310	—	556 314	941 262	930 533
FASC 200	8.0	200	6.7	170	10.9	278.5	1.7	0.8	556 320	—	556 324	941 263	930 535
FASC 300	12.0	300	11.3	288	14.9	378.5	1.9	0.9	556 330	556 333	—	941 264	930 537
FASC 400	16.0	400	11.3	288	18.8	478.5	2.4	1.1	556 340	—	—	943 096	—
FASC 450	18.0	450	11.3	288	20.8	528.5	2.8	1.3	556 350	—	—	942 596	—

– Contact manufacturer for availability.

CSC STANDARD C BRACKET

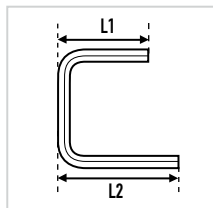
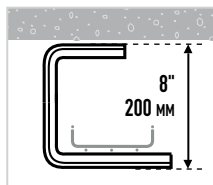

- For cable tray installations under ceiling or overhangs.
- Can be stacked for multilevel Cablofil tray installations.
- EZ BN 1/4 and CE 25 are sold separately. **(see pg. A.81).**

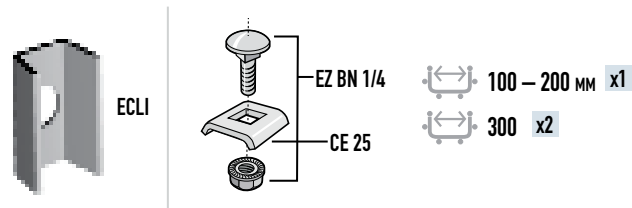

	WIDTH		LENGTH (L1)		LENGTH (L2)		WEIGHT		PG	GC	316L	BL	PE
	INCHES	MM	INCHES	MM	INCHES	MM	LBS	KG					
CSC 100	4.0	100	5.1	130	5.7	145	1.1	0.5	002 760	—	—	941 136	930 082
CSC 200	8.0	200	7.1	180	9.6	245	1.4	0.7	002 770	—	002 774	941 137	930 084
CSC 300	12.0	300	9.1	230	13.6	345	1.8	0.8	002 780	—	—	941 138	930 086

– Contact manufacturer for availability.



CS / PS PENDANT L BRACKETS

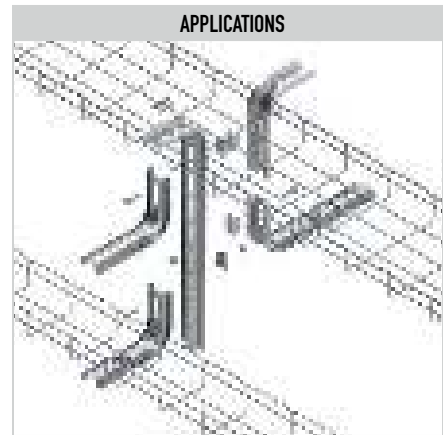

APPLICATIONS

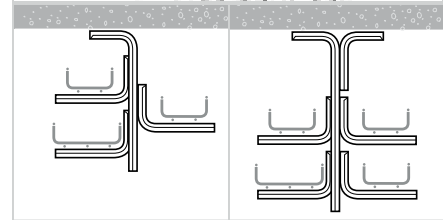

- Versatile brackets that can be configured to create numerous ceiling-hung installations.
- Slotted holes allow for adjustments during installation.
- Tray attachment hardware sold separately. **See p. A.81.**
- Sold individually.

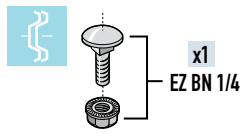
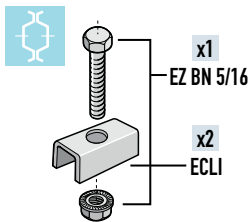

	WIDTH		LENGTH		WEIGHT		PG	GC	316L	BL	PE
	INCHES	MM	INCHES	MM	LBS	KG					
CS 100	4.0	100	5.7	145	0.4	0.2	002 700	–	002 704	941 130	930 070
CS 200	8.0	200	9.6	245	0.8	0.4	002 710	002 713	–	941 131	930 072
CS 300	12.0	300	13.6	345	1.2	0.5	002 720	–	002 724	941 132	930 074
PS 400	16.0	400	17.5	445	1.5	0.7	002 730	–	–	941 133	930 076
PS 500	20.0	500	21.4	545	1.8	0.8	002 740	–	–	941 134	930 078
PS 600	24.0	600	25.4	645	2.1	0.9	002 750	–	–	941 135	930 080

– Contact manufacturer for availability.



**EDF
RAIL**

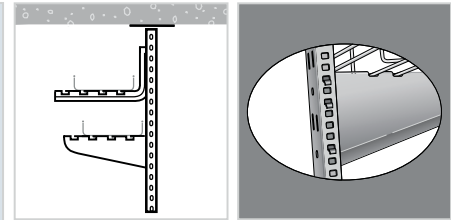
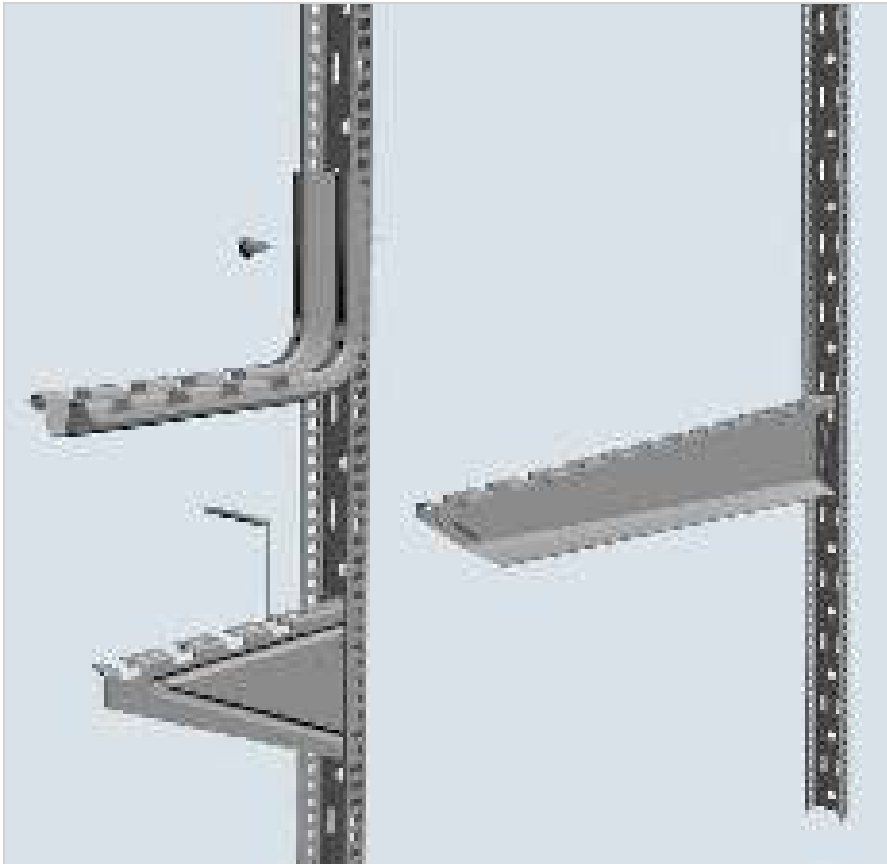

- EDF Rail makes tiered tray runs easier and faster to install.
- CA Pin (sold separately) is required to install 4" to 12" FASU. Suggested for 16" to 24" FASU.
- FASU sizes 16" to 24" will snap directly onto EDF Rail.
- Use EZ BN 1/4 (sold separately) to attach any FAS L to EDF Rail.

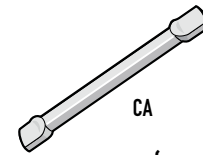

CA

(see pg. A.81)

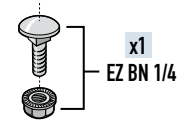

x1

EZ BN 1/4

	LENGTH		WEIGHT		PG	GC	316L	BL	PE
	INCHES	MM	LBS	KG					
EDF 300	10.6	270	0.7	0.3	561 310	–	–	942 817	942 818
EDF 600	24.8	630	1.8	0.8	557 610	–	–	942 815	942 816
EDF 1000	39.0	990	2.6	1.2	561 090	–	–	942 813	942 814
EDF 2000	78.0	2000	5.5	2.5	561 010	–	–	941 288	930 641
EDF 3000	120.0	3000	9.1	4.1	561 020	–	–	941 289	930 643

– Contact manufacturer for availability.

APPLICATIONS

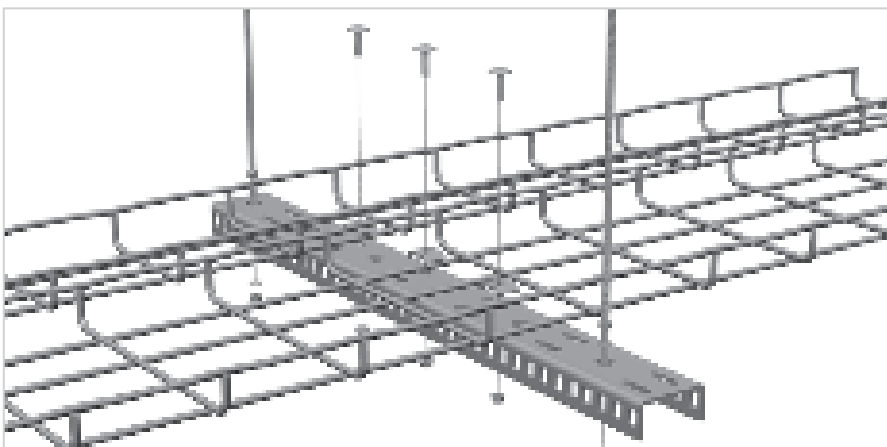

PFREDF MOUNTING BRACKET

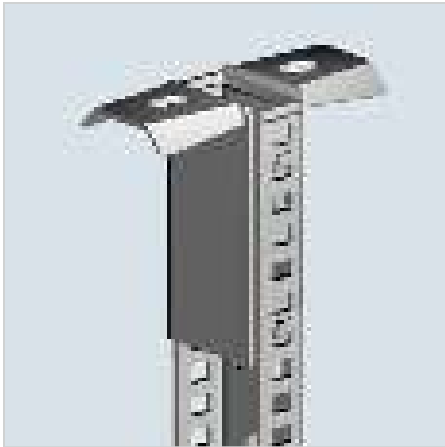

- Use PFREDF to attach EDF Rail directly to ceiling.
- EDF Rail attaches to PFREDF without additional hardware.

	WEIGHT		PG	316L	BL	PE
	LBS	KG				
PFREDF	1.3	0.6	561 080	–	942 761	942 762

– Contact manufacturer for availability.

DF ANGLE MOUNTING BRACKET

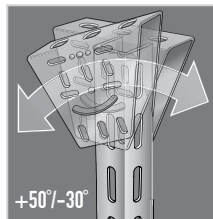
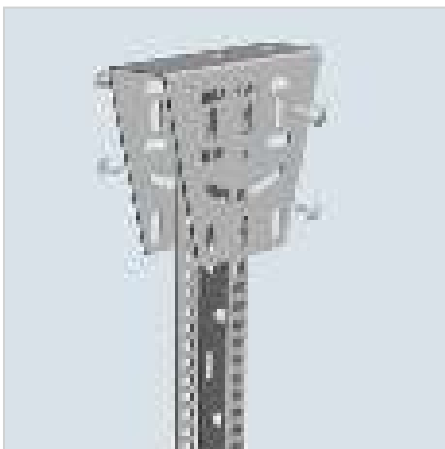

- Use DF to attach EDF Rail to any angled ceiling.
- Attach EDF Rail to DF with EZ BN 5/16
(sold separately-see pg. A.81).

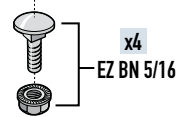

	WEIGHT		PG	GC	316L	BL	PE
	LBS	KG					
DF	1.3	0.6	561 060	–	–	942 880	–

– Contact manufacturer for availability.

ERD 10 BRACE PLATE

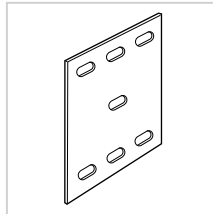
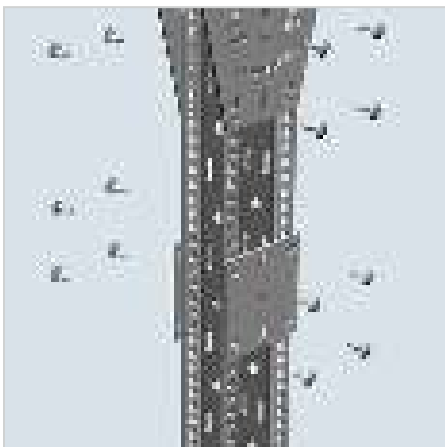

- Use ERD 10 to assemble double-sided ceiling hung tray runs.
- Attach EDF Rail to ERD 10 with EZ BN 5/16
(sold separately-see pg. A.81).

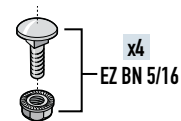

	WEIGHT		PG	GC	BL	PE
	LBS	KG				
ERD 10	0.4	0.5	561 050	–	942 759	942 760

– Contact manufacturer for availability.



UNDERFLOOR



A.49 UFC 550 KIT
UNDER FLOOR
SUPPORT CLAMP KIT

A.49 UFC
UNDER FLOOR
SUPPORT CLAMP

A.50 FAS P
FAS PROFILE

A.50 UFCN
UNDER FLOOR CLAMP

A.51 UC 50
CABLE TRAY STANDOFF

A.51 C 50
UNDER FLOOR
ATTACHMENT

A.52 FAS L
BRACKET

A.52 FAS U
UNIVERSAL BRACKET

A.53 EDF
RAIL

A.53 DF
ANGLE MOUNTING BRACKET

A.54 UFS
UNDER FLOOR SUPPORT

A.54 UFS
UNDER FLOOR
SUPPORT BRACKET

A.55 UFFS
UNDER FLOOR FIBERGLASS
SUPPORT STAND

A.56 UFS
UNDER FLOOR CABLE
MANAGEMENT SYSTEM

A.56 UFSUPKIT
UFS SUPPORT KIT

A.56 UFSCB 4/300PG
UFS CANTILEVER BRACKET

A.57 UFCF2
UFS WIRE TRAY SECTION

A.57 UFT 90° KIT

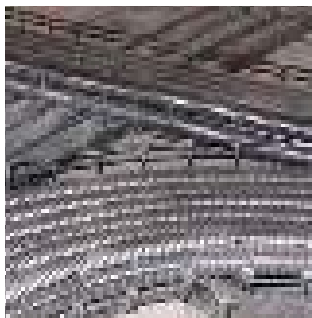

Legrand offers a wide variety of Cablofil options for raised access floor installations, the newest being the UFS Underfloor Cable management system. UFS is independently supported so that it doesn't void the warranty of the raised access floor and it is engineered with 2ft. tray sections so that it can be installed entirely through the floor openings.

UFC550 KIT UNDER FLOOR SUPPORT CLAMP KIT

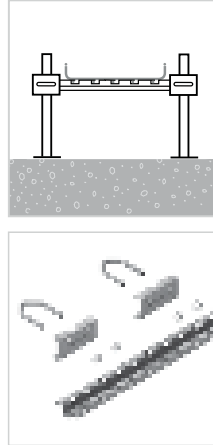

- Creates a tray support between two floor supports for Cablofil tray runs.
- To install, clamp UFC to raised floor supports then bolt FAS P 550 to UFC clamps.
- Use patented locking tabs on FAS P 550 to secure tray without additional hardware.
- Kit contains two UFC clamps, two EZ BN 1/4 and one FAS P 550.

	PKG QTY	WEIGHT		PG	BL	PE
		LBS	KG			
UFC550 KIT	1	0.7	0.3	943 179	943 180	943 181

UFC UNDER FLOOR SUPPORT CLAMP

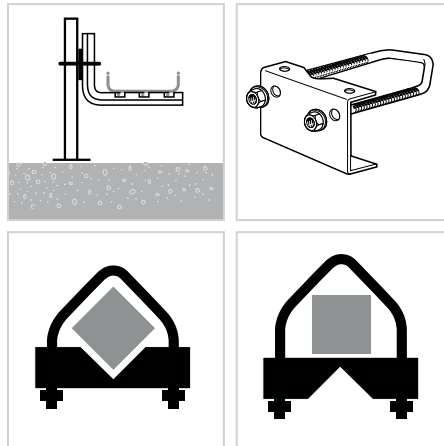

- Creates a tray support using FAS L brackets in under floor applications.
- To install, clamp FAS L Brackets to raised floor support through **one side of U-bolt ONLY**.
- UFC clamp works with round or square post profiles.
- Turn UFC support plate around if post faces are parallel with floor grid.

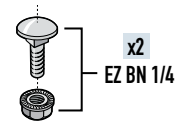

	LENGTH		WEIGHT		PG	BL	PE
	INCHES	MM	LBS	KG			
UFC	5.0	127	0.7	0.3	559 220	941 287	934 043



FAS P
FAS PROFILE

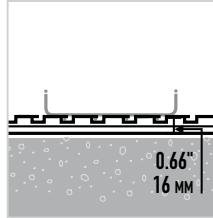

- Pre-drilled holes make installation easy.
- Will hold tray away from floor 0.66".
- Saves installation time – patented FAS style attachment hold Cablofil tray secure without nuts and bolts.

	LENGTH		WEIGHT		PG	GC	316L	BL	PE
	INCHES	MM	LBS	KG					
FASP 150	6.0	150	0.4	0.2	014 150	014 153	014 154	941 153	930 012
FASP 200	8.0	200	0.7	0.3	014 200	014 203	014 204	941 154	930 014
FASP 300	12.0	300	0.9	0.4	014 300	014 303	014 304	941 155	930 016
FASP 400	16.0	400	1.1	0.5	014 400	014 403	014 404	941 156	930 018
FASP 450	18.0	450	1.2	0.6	014 450	–	–	941 157	930 020
FASP 500	20.0	500	1.3	0.6	014 500	–	–	941 158	930 022
FASP 550	22.0	550	1.3	0.6	014 550	014 553	–	941 159	930 024
FASP 600	24.0	600	1.5	0.7	014 600	014 603	014 604	941 160	930 026
FASP 700	28.0	700	1.8	0.8	014 700	–	014 704	941 162	930 028
FASP 1000	40.0	1000	2.6	1.2	014 010	–	014 014	941 149	930 006
FASP 2000	80.0	2000	5.3	2.4	014 020	–	–	941 151	930 008
FASP 3000	120.0	3000	7.9	3.6	014 030	014 033	014 034	941 152	930 010

– Contact manufacturer for availability.

UFCN
UNDER FLOOR CLAMP

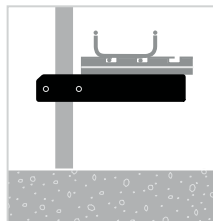
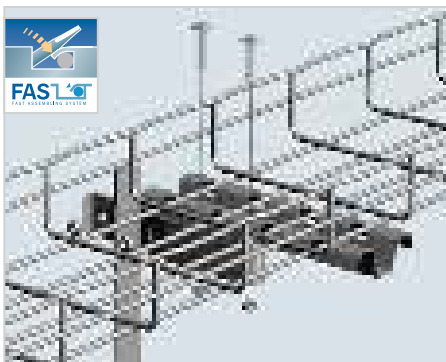

- UFCN includes clamp, pre-assembled FAS Profile, nuts and bolts.
- Clamp attaches to square or round support posts.
- FAS Profile secures tray without additional hardware.
- Adjusts to any height.

	LENGTH		WEIGHT		PG	GC	BL	PE
	INCHES	MM	LBS	KG				
UFCN 150	6	150	2.5	1.0	942 839	–	943 149	942 838
UFCN 200	8	200	2.7	1.2	942 448	–	942 341	942 413
UFCN 300	12	300	3.0	1.4	942 449	–	942 342	942 414

– Contact manufacturer for availability.

UC 50 CABLE TRAY STANDOFF

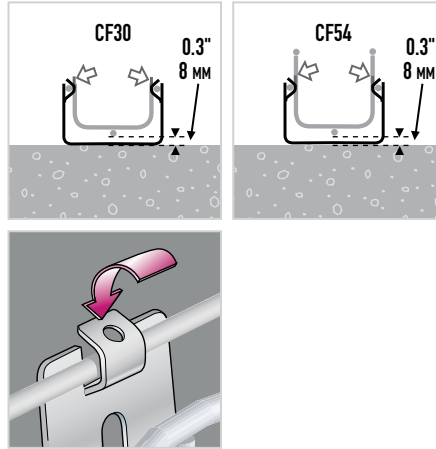
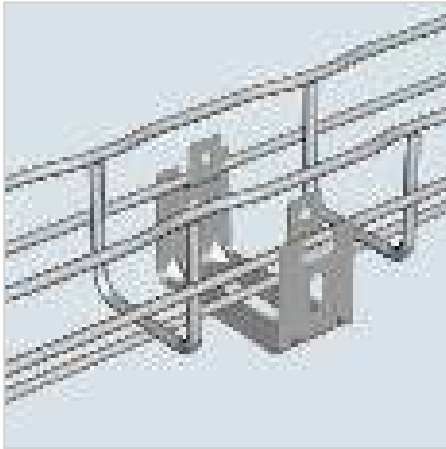

- Attaches 2" wide tray to floor and channel framing.
- Fold over tabs secure tray without fasteners.
- Stand-off height is 0.3" (8mm).

	WEIGHT		PG	GC	316L	BL	PE
	LBS	KG					
UC 50	0.1	0.06	586 040	-	-	941 304	930 681

- Contact manufacturer for availability.

C 50 UNDER FLOOR ATTACHMENT

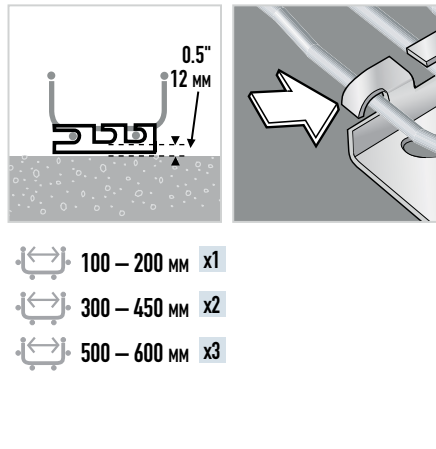
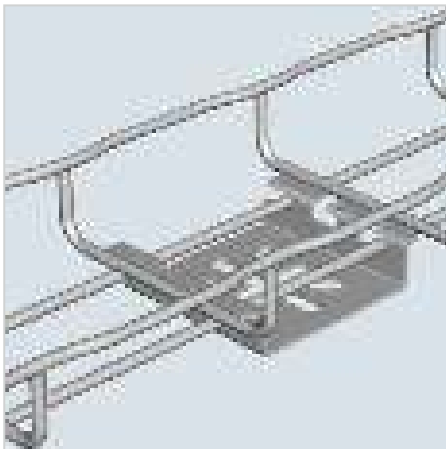

- Attaches tray to floor and channel framing.
- Fold over tabs secure tray without additional hardware.
- Slotted mounting holes make for adjustable installations.

	WEIGHT		PG	GC	316L	BL	PE
	LBS	KG					
C 50	0.2	0.1	586 130	-	-	941 308	930 694

- Contact manufacturer for availability.



FAS L BRACKET

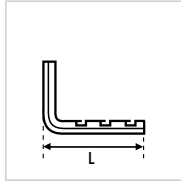
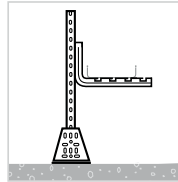
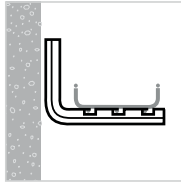

- Use for tray support in under floor applications in combination with UFC Clamp or EDF Rail.
- Use patented locking tabs on FAS L to secure tray without additional hardware.
- Order "width" to match tray.

	TRAY WIDTH		LENGTH		WEIGHT		PG	GC	304L	316L	BL	PE
	INCHES	MM	INCHES	MM	LBS	KG						
FASL 100	4.0	100	7.0	178.5	0.9	0.4	556 100	556 103	—	556 104	941 257	930 523
FASL 150	6.0	150	9.0	228.5	1.0	0.5	556 110	556 113	—	556 114	941 258	930 525
FASL 200	8.0	200	11.0	278.5	1.1	0.5	556 120	556 123	—	556 124	941 259	930 527
FASL 300	12.0	300	14.9	378.5	1.4	0.6	556 130	556 133	—	556 134	941 260	930 529
FASL 400	16.0	400	18.8	478.5	1.8	0.8	556 140	—	—	—	943 146	943 388
FASL 450	18.0	450	20.8	528.5	2.1	1.0	556 150	—	—	—	942 848	942 600

– Contact manufacturer for availability.

FAS U UNIVERSAL BRACKET

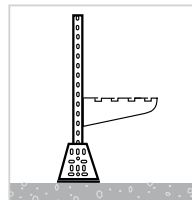

- Use for tray support in under floor applications in combination with EDF Rail.
- Use patented locking tabs on FAS U to secure tray without additional hardware.
- Supports wider tray and heavier loads than FAS L.
- FAS U snaps directly into EDF rail.

	HEIGHT		TRAY WIDTH		LENGTH		WEIGHT		PG	GC	316L	BL	PE
	INCHES	MM	INCHES	MM	INCHES	MM	LBS	KG					
FASU 100	3.5	85	4.0	100	6.0	157	0.3	0.1	557 410	—	557 414	941 267	930 575
FASU 150	5.0	124	6.0	150	8.0	207	0.4	0.2	557 420	557 423	557 424	941 268	930 577
FASU 200	5.5	139	8.0	200	12.0	257	0.5	0.2	557 430	557 433	557 434	941 269	930 579
FASU 300	5.5	139	12.0	300	14.0	357	0.8	0.3	557 440	557 443	557 444	941 270	930 581
FASU 400	5.5	137.7	16.0	400	18.0	457	1.8	0.8	557 450	557 453	557 454	941 271	930 583
FASU 450	5.5	137.7	18.0	450	20.0	507	2.4	1.1	944 533	—	—	944 536	944 937
FASU 500	5.5	137.7	20.0	500	22.0	557	2.9	1.3	557 460	557 463	—	941 272	930 585
FASU 600	5.5	137.7	24.0	600	26.0	657	6.4	2.9	557 470	—	—	941 273	930 587

– Contact manufacturer for availability.



EDF RAIL

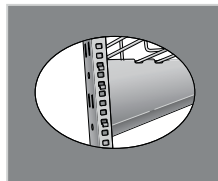
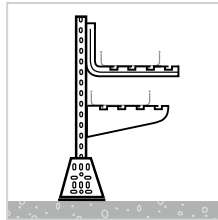
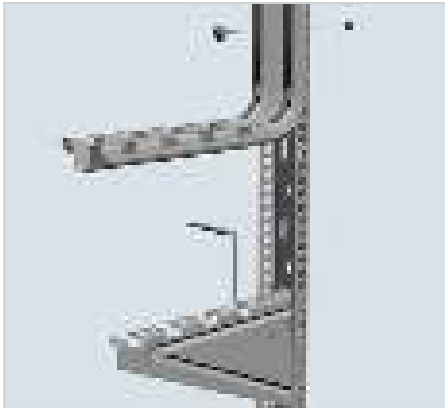

- EDF Rail makes multiple floor mounted cable tray runs easier and faster to install.
- CA Pin (sold separately) is required to install 4" to 12" FASU. Suggested for 16" to 24" FASU.
- FASU sizes 16" to 24" will snap directly onto EDF Rail.
- Use EZ BN 5/16 (sold separately) to attach any FAS L to EDF Rail.

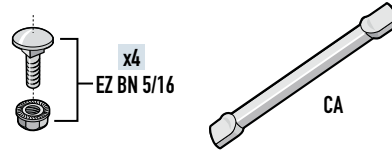

	LENGTH		WEIGHT		PG	GC	316L	BL	PE
	INCHES	MM	LBS	KG					
EDF 300	10.6	270	0.7	0.3	561 310	—	—	942 817	942 818
EDF 600	24.8	630	1.8	0.8	557 610	—	—	942 815	942 816
EDF 1000	39.0	990	2.6	1.2	561 090	—	—	942 813	942 814
EDF 2000	78	2000	5.5	2.5	561 010	—	—	941 288	930 641
EDF 3000	120	3000	9.1	4.1	561 020	—	—	941 289	930 643

– Contact manufacturer for availability.

APPLICATIONS

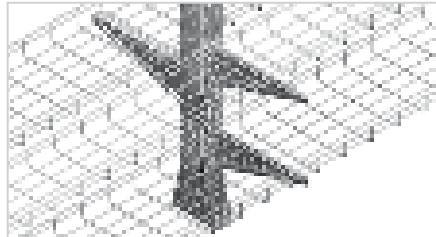
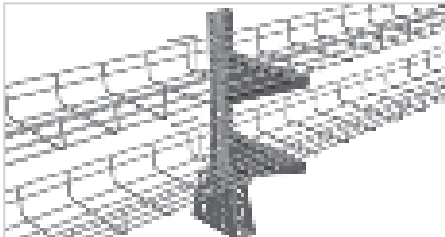

DF ANGLE MOUNTING BRACKET

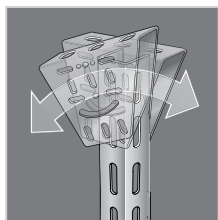
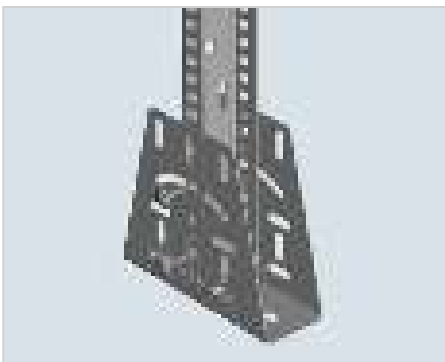

- Use DF to attach EDF Rail to any floor.
- Attach EDF Rail to DF with EZ BN 5/16 (sold separately).
- Use DF to attach EDF to a ceiling or deck that is on an angle for a perfect pendant hanger.

	WEIGHT		PG	GC	316L	BL	PE
	LBS	KG					
DF	1.3	0.6	561 060	—	—	942 880	—

– Contact manufacturer for availability.



UFS
UNDER FLOOR SUPPORT

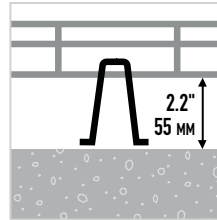
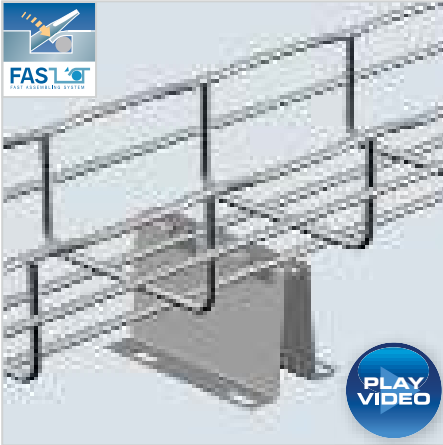

- Pre-drilled mounting holes make installations easy.
- UFS can be used as a stand off support on equipment cabinets to avoid covering ventilation fans.
- Saves installation time—patented FAS style attachment holds tray secure without nuts and bolts.

- 100 – 200 MM x1
- 300 – 450 MM x2
- 500 MM x3

	WIDTH		LENGTH		WEIGHT		PG	GC	316L	BL	PE
	INCHES	MM	INCHES	MM	LBS	KG					
UFS 60/100	2.4	60	4.0	100	0.2	0.1	586 080	–	–	941 307	930 689

– Contact manufacturer for availability.

UFS
UNDER FLOOR SUPPORT BRACKET

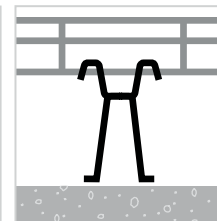
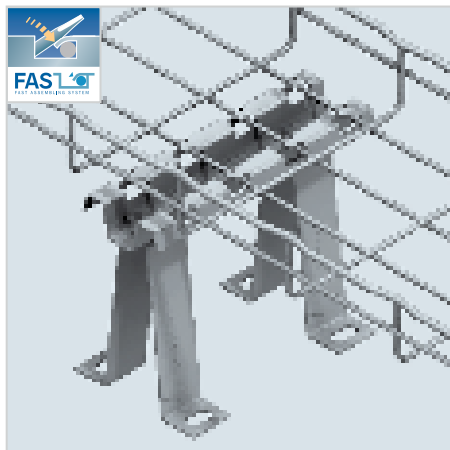

- Raises cable pathway within easy reach of floor openings.
- Slotted mounting holes allow for quick attachment to floor deck.
- Installs quickly – patented FAS locking tabs require no additional hardware to secure tray.
- Supports tray independently of raised floor systems.

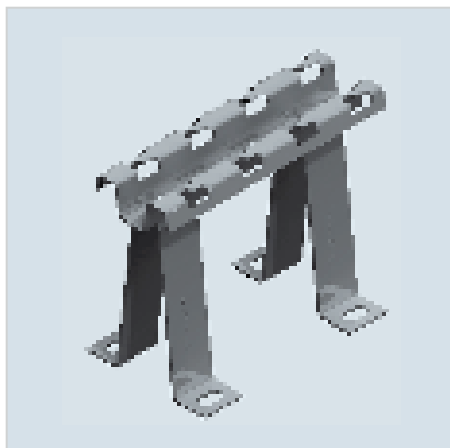

	HEIGHT		LENGTH		FOR TRAY SIZE		WEIGHT		PG
	INCHES	MM	INCHES	MM	INCHES	MM	LBS	KG	
UFS 100/150	4.0	100	6.0	150	6.0	150	1.7	0.77	943 306
UFS 100/200	4.0	100	8.0	200	8.0	200	1.9	0.86	943 307
UFS 100/300	4.0	100	12.0	300	12.0	300	2.1	0.95	943 308
UFS 100/450	4.0	100	18.0	450	18.0	450	2.4	1.09	943 309
UFS 100/500	4.0	100	20.0	500	20.0	500	2.5	1.13	943 310
UFS 150/150	6.0	150	6.0	150	6.0	150	2.1	0.93	943 311
UFS 150/200	6.0	150	8.0	200	8.0	200	2.3	1.06	942 354
UFS 150/300	6.0	150	12.0	300	12.0	300	2.5	1.15	943 312
UFS 150/450	6.0	150	18.0	450	18.0	450	2.8	1.29	943 313
UFS 150/500	6.0	150	20.0	500	20.0	500	2.9	1.33	943 314
UFS 200/150	8.0	200	6.0	150	6.0	150	2.5	1.12	943 315
UFS 200/200	8.0	200	8.0	200	8.0	200	2.8	1.25	943 316
UFS 200/300	8.0	200	12.0	300	12.0	300	3.0	1.34	943 317
UFS 200/450	8.0	200	18.0	450	18.0	450	3.3	1.48	943 318
UFS 200/500	8.0	200	20.0	500	20.0	500	3.4	1.52	943 319
UFS 300/150	12.0	300	6.0	150	6.0	150	3.3	1.50	943 320
UFS 300/200	12.0	300	8.0	200	8.0	200	3.6	1.63	943 321
UFS 300/300	12.0	300	12.0	300	12.0	300	3.8	1.72	943 322
UFS 300/450	12.0	300	18.0	450	18.0	450	4.1	1.86	943 323
UFS 300/500	12.0	300	20.0	500	20.0	500	4.2	1.91	943 324



UFFS UNDER FLOOR FIBERGLASS SUPPORT STAND

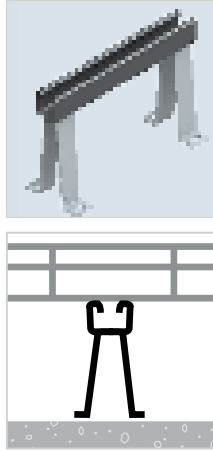
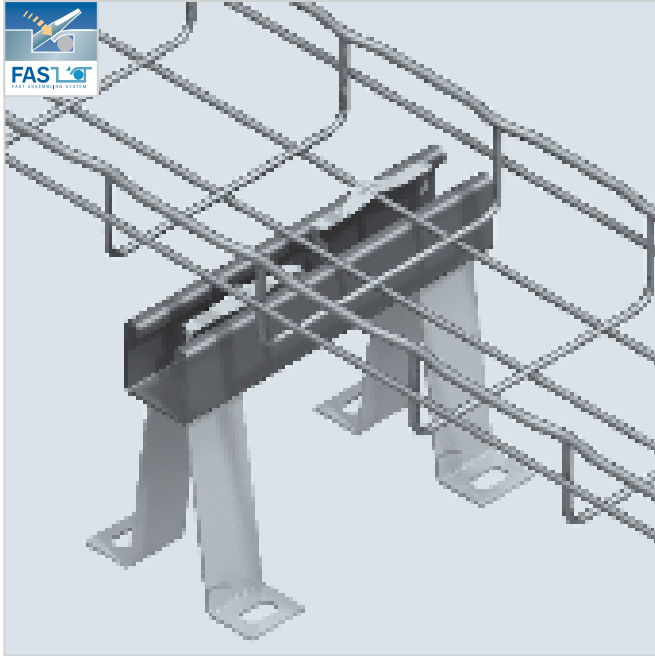

- Raises cable pathway within easy reach of floor openings.
- Fiberglass strut design keeps cable pathway insulated from floor deck.
- Slotted mounting holes allow for quick attachment to floor deck.
- Use FS 41 Fastrut connectors to secure tray to mounting bracket (not included).
- Supports tray independently of raised floor systems.

	HEIGHT		LENGTH		FOR TRAY SIZE		WEIGHT		PG
	INCHES	MM	INCHES	MM	INCHES	MM	LBS	KG	
UFFS100/200*	4.0	100	7.87	200	6.0	150	1.6	0.73	943 325
UFFS100/250**	4.0	100	9.84	250	8.0	200	1.7	0.77	943 326
UFFS100/300	4.0	100	11.81	300	12.0	300	1.8	0.82	943 327
UFFS100/450	4.0	100	17.71	450	18.0	450	2.1	0.95	943 328
UFFS100/500	4.0	100	19.68	500	20.0	500	2.2	1.0	943 329
UFFS150/200*	6.0	150	7.87	200	6.0	150	2.0	0.91	943 330
UFFS150/250**	6.0	150	9.84	250	8.0	200	2.1	0.95	943 331
UFFS150/300	6.0	150	11.81	300	12.0	300	2.2	1.0	943 332
UFFS150/450	6.0	150	17.71	450	18.0	450	2.5	1.13	943 333
UFFS150/500	6.0	150	19.68	500	20.0	500	2.6	1.18	943 334
UFFS200/200*	8.0	200	7.87	200	6.0	150	2.5	1.13	943 335
UFFS200/250**	8.0	200	9.84	250	8.0	200	2.6	1.18	943 336
UFFS200/300	8.0	200	11.81	300	12.0	300	2.7	1.22	943 337
UFFS200/450	8.0	200	17.71	450	18.0	450	3.0	1.36	943 338
UFFS200/500	8.0	200	19.68	500	20.0	500	3.1	1.41	943 339
UFFS300/200*	12.0	300	7.87	200	6.0	150	3.3	1.50	943 340
UFFS300/250**	12.0	300	9.84	250	8.0	200	3.4	1.54	943 341
UFFS300/300	12.0	300	11.81	300	12.0	300	3.5	1.59	943 342
UFFS300/450	12.0	300	17.71	450	18.0	450	3.8	1.72	943 343
UFFS300/500	12.0	300	19.68	500	20.0	500	3.9	1.77	943 344

* Use with 150 Series Wide Tray ** Use with 200 Series Wide Tray



UFS UNDER FLOOR CABLE MANAGEMENT SYSTEM



- Designed to work with all standard raised access floors.
- Self supporting – won't void the warranty of your floor.
- UFS 2' tray sections allow for easy installation through the floor openings.
- UFS support kits can utilize standard 10' tray sections.
- 18" (450mm) and 20" (500mm) for use on top tier only.
- UFS installs with simple tools – no hardware needed.

UFSUPKIT UFS SUPPORT KIT

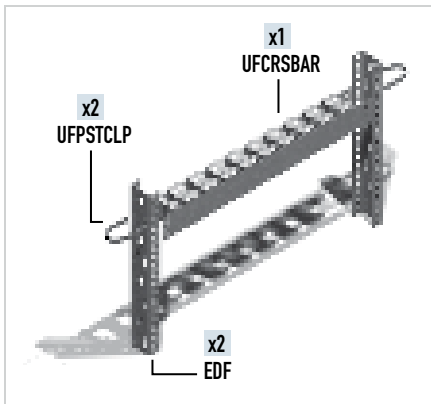

- Crossbars secure tray with FAS style tabs – only a screwdriver is needed.
- Heavy-duty legs have multiple mounting holes for almost infinite height adjustment.
- Attachment clips secure installation to raised access floor legs.

	PKG. QTY.	HEIGHT		WIDTH		PG
		INCHES	MM	INCHES	MM	
UFS SUPPORT KITS						
UFSUPKIT100*	1	3.5	90	22.0	550	942 918
UFSUPKIT200*	1	7.0	130	22.0	550	942 919
UFSUPKIT300*	1	10.6	270	22.0	550	942 920
UFSUPKIT400*	1	14.0	360	22.0	550	942 921
UFSUPKIT600*	1	24.8	630	22.0	550	942 922
* Each Support Kit includes 1 Crossbar, 2 Leg Supports and 2 Leg Attachment Clips.						
Kit Components May Be Ordered Individually						
CROSSBARS						
UFCRSBAR	1	2.4	60	22.0	550	589 010
LEGS						
EDF100	1	3.5	90	–	–	561 320
EDF200	1	7.0	130	–	–	561 330
EDF300	1	10.6	270	–	–	561 310
EDF400	1	14.0	360	–	–	561 340
EDF450	1	17.7	450	–	–	561 350
EDF500	1	21.2	540	–	–	557 360
EDF600	1	24.8	630	–	–	557 610
LEG ATTACHMENT CLIPS						
UFPSTCLPPG	2	–	–	–	–	589 110

UFSCB UFS CANTILEVER BRACKET

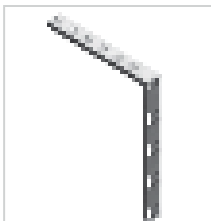
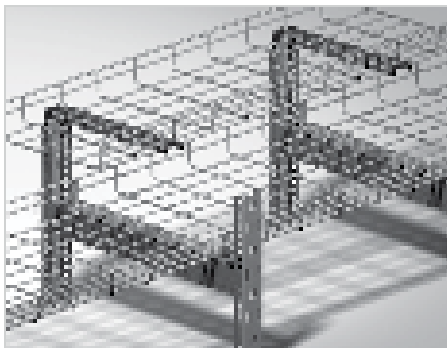

- Vertical leg can be cut to accommodate shorter elevations.
- Allow multiple tray levels without obstructing access to lower level.
- No hardware required.

	PKG QTY	WEIGHT		PG
		LBS	KG	
UFSCB 4/300PG	1	0.50	0.22	943 029

APPLICATIONS



UFCF2
UFS WIRE TRAY SECTION

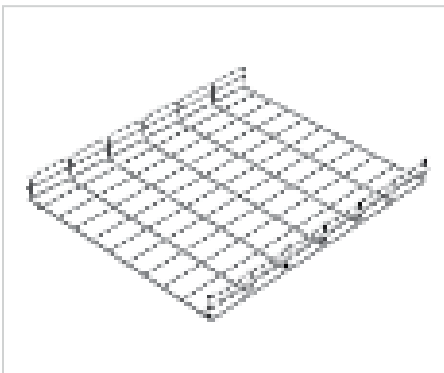

- UFCF tray will accept all Cablofil accessories without adjustment.

	PKG. QTY.	HEIGHT		WIDTH		LENGTH		EZ
		INCHES	MM	INCHES	MM	INCHES	MM	
UFCF2/54/300	1	2.0	54	12.0	300	24.0	600	600 261
UFCF2/54/400	1	2.0	54	16.0	400	24.0	600	600 291
UFCF2/54/500*	1	2.0	54	20.0	500	24.0	600	600 301
UFCF2/105/150	1	4.0	105	6.0	150	24.0	600	942 945
UFCF2/105/300	1	4.0	105	12.0	300	24.0	600	600 661
UFCF2/105/400	1	4.0	105	16.0	400	24.0	600	600 691
UFCF2/105/500*	1	4.0	105	20.0	500	24.0	600	600 701
UFCF2/150/300	1	6.0	150	12.0	300	24.0	600	600 861
UFCF2/150/400	1	6.0	150	16.0	400	24.0	600	600 891
UFCF2/150/500*	1	6.0	150	20.0	500	24.0	600	600 901

* 18" and 20" for use in top tier only.

UFT 90° KITS

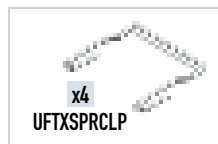
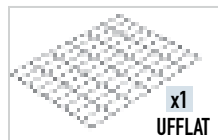
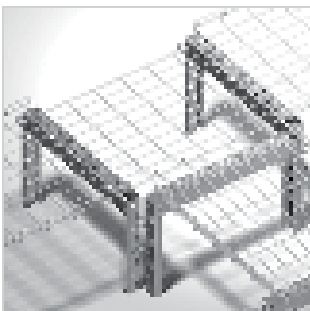

	PKG. QTY.	WIDTH		LENGTH		PG	EZ	GC
		INCHES	MM	INCHES	MM			
UFT90KIT*	1	18.0	450	24.0	600	-	942 923	-
* Each 90° Kit includes 1 Flat Tray Section and 6 Securing Clips.								
Kit Components May Be Ordered Individually								
CORNER OR JUNCTION TRAY/CLIPS								
UFFLAT	1	18.0	450	24.0	600	-	942 917	-
UFTXSPRCLP	1	-	-	-	-	589 210	-	-

- Contact manufacturer for availability.

- Use UFT 90 Kit at tees and junctions.



UFS HOW TO ORDER CABLOFIL UNDER FLOOR SYSTEMS

Planning and ordering UFS for any raised access floor is simple if you follow these steps.

PLANNING

1. **Review a scale drawing of the installation defining the planned cable pathways.** Consider multiple levels of cable trays within the installation, ie. all data cables on the 12" level and all power cables on the 4" level (see Diagram A.).
2. **Determine the number of cables needed in the pathway.** It's a good rule to allow for 50% additional capacity for future moves, adds and changes.
3. **Refer to the Cablofil Load/Fill calculator at www.legrand.us/cablofil to determine tray size.** Specify the exact cable size(s) when making this calculation.
4. **Determine the leg height for each level of tray.** Add the tray depth to the leg height to make sure your installation clears the lowest part of the floor and other tray runs. (see Diagram B).
5. **Confirm the tray width you are planning is compatible with your leg selection.** The EDF legs in the UFS system can support multiple levels of tray – however, 500mm tray can only be used when the crossbar is installed at the top of any leg.

ORDERING

1. **Determine the amount of straight tray sections needed.** Consider tray length options. Save labor and use 10' sections when tray is installed before floor installation – use 2' tray for installation in an existing floor.
2. **Determine the number of support kits needed for each tray level.** Support 2' tray at every junction of the raised access floor or every 2'. For 10' tray, supports are used every 8'. Additional supports will be needed at ends of runs and at T's and corners.
3. **Count the number of 90° corners, T's and junctions.** The UFT90KIT works with any size or depth of tray.
4. **Send a completed bill of materials (and a copy of your scale drawing) to your Legrand representative for review and a price quotation** (see Diagram C.).

DIAGRAM A.
EXAMPLE OF UFS IN 12' X 12' RAISED ACCESS FLOOR

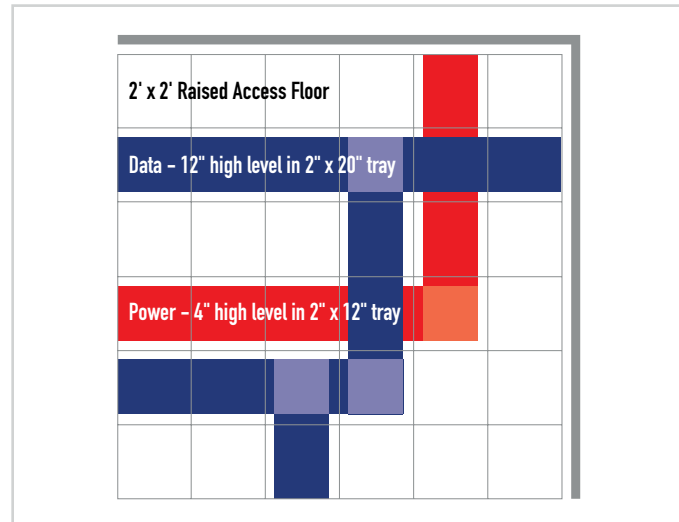

DIAGRAM B.
EXAMPLE OF INSTALLATION WITH MULTIPLE LEVELS

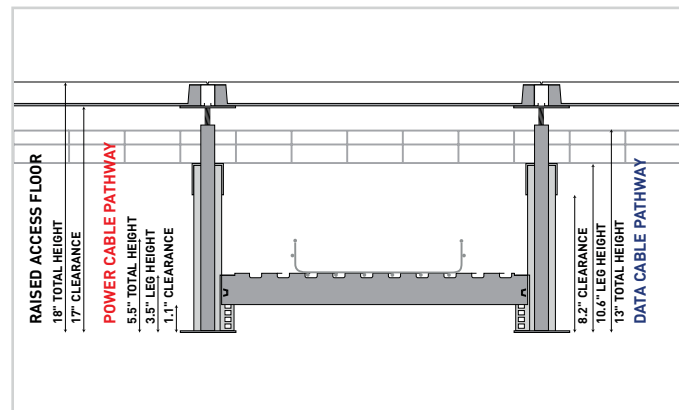

DIAGRAM C.
EXAMPLE OF BILL OF MATERIALS

	QTY.	PART OR KIT #
DATA CABLE PATHWAY		
	10	UFCF2/54/500
	17	UFTUPKIT300
	3	UFT90KIT
POWER CABLE PATHWAY		
	7	UFC2/54/300
	10	UFTUPKIT100
	1	UFT90KIT

UFS HOW TO INSTALL CABLOFIL UNDER FLOOR SYSTEMS

UFS Under Floor System is designed to reduce labor costs in raised access floor applications. All parts of the system assemble with little or no attachment hardware and require only simple tools. For more information, please contact your local Legrand representative.

1



Assemble both leg sections to crossbars.

4



Place 2' tray sections in position.

2



Using a screwdriver, secure assembly by bending small tab on each leg. All leg support sections can be assembled in advance or offsite for greater efficiency.

5



Bend FAS style tabs with screwdriver to secure tray. Double rows of FAS tabs on UFS crossbars act as tray splices.

3



Place assembly leg supports in position and loosely secure to floor legs with serrated attachment clips.

6



Use a UFT90KIT for corners, tees, and junctions. Secure with tray clips.



FIBER OPTIC

- A.61 EZT90RS**
90° RADIUS SHIELDS
- A.61 RADT90RS**
90° RADIUS SHIELDS
- A.62 HXB**
HORIZONTAL CROSS BRIDGE
- A.62 RHXB**
REDUCING HORIZONTAL
CROSS BRIDGE
- A.62 HTB**
HORIZONTAL TEE BRIDGE
- A.63 BH75KIT**
BRIDGE HORN KIT
- A.63 INSERTPP**
PLASTIC INSERTS
- A.64 OTDOFAS**
OVER-THE-TOP DROP OUT
- A.64 OTDO**
OVER-THE-TOP WATERFALL
- A.65 CABLEXIT50**
CABLE EXIT
- A.65 TOH**
FIBER-OPTIC TWIST-ON HORN



Cablofil is perfectly suited for fiber-optic cabling with accessories that create large radius bends and dropouts that keep cables functioning at the highest specification. This accessory line also includes new flexible tray inserts that keep cabling uniformly supported and a series of junction bridges for tee and 4-way tray intersections.

EZT90RS 90° RADIUS SHIELDS

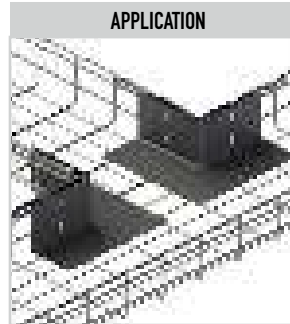

- Use in conjunction with EZT 90 KIT
- Protects cable from rough edges at cable pathway junctions
- Slotted, ABS design installs with zip ties (included)
- One size fits CF54, CF105 and CF150 tray heights – just trim to fit
- Sold in pairs

	PKG. QTY.	WEIGHT		PL*
		LBS	KG	
EZT90RS	1	.208	.094	944 768

*PL = Plastic

RADT90RS 90° RADIUS SHIELDS



- Use in conjunction with RADT 90 KIT
- Protects cable from rough edges at cable pathway junctions
- Slotted, ABS design installs with zip ties (included)
- One size fits CF54, CF105 and CF150 tray heights – just trim to fit
- Sold in pairs

	PKG. QTY.	WEIGHT		PL*
		LBS	KG	
RADT90RS	1	.197	.089	944 770

*PL = Plastic



HXB HORIZONTAL CROSS BRIDGE

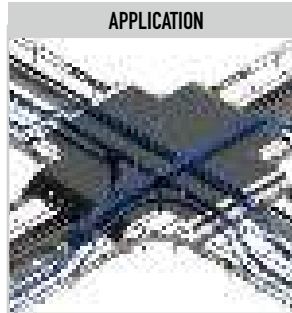

- Keeps cabling separated in horizontal tray crossings
- Durable steel construction with Pre-galvanized and Black powder coated finishes
- Mounts to tray with included BC1 Bridge Clip and self-tapping screws
- Use cable ties in slotted holes to secure cables
- All mounting holes are pre-drilled
- Use on CF54, CF105 and CF150 tray
- Fits 12" (300 mm) tray widths

	TRAY WIDTH		TRAY WIDTH 2		WEIGHT		PG	BL
	INCHES	MM	INCHES	MM	LBS	KG		
HXB300	12"	300	12"	300	8.74	3.96	944734	944735

RHXB REDUCING HORIZONTAL CROSS BRIDGE



- Keeps cabling separated in horizontal tray crossings
- Durable steel construction with Pre-galvanized and Black powder coated finishes
- Mounts to tray with included BC1 Bridge Clip and self-tapping screws
- Use cable ties in slotted holes to secure cables
- All mounting holes are pre-drilled
- Use on CF54, CF105 and CF150 tray
- Fits tray intersections of 24" (600 mm) and 18" (450 mm) tray widths

	TRAY WIDTH		TRAY WIDTH 2		WEIGHT		PG	BL
	INCHES	MM	INCHES	MM	LBS	KG		
RHXB600-450	24"	600	18"	450	14.21	6.44	944723	944725

HTB HORIZONTAL TEE BRIDGE

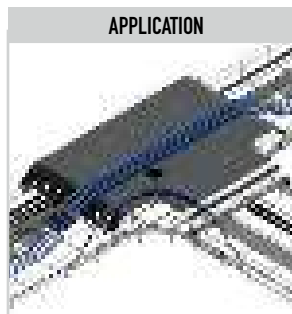

- Keeps cabling separated in horizontal tee junctions
- Durable steel construction with Pre-galvanized and Black powder coated finishes
- Mounts to tray with included BC1 Bridge Clip and self-tapping screws
- Use cable ties in slotted holes to secure cables
- All mounting holes are pre-drilled
- Use on CF54, CF105 and CF150 tray
- Fits 12" (300 mm) tray widths
- Available in a reducing option

	TRAY WIDTH		TRAY WIDTH 2		WEIGHT		PG	BL
	INCHES	MM	INCHES	MM	LBS	KG		
HTB300	12"	300	12"	300	7.23	3.27	944736	944737

BH75KIT BRIDGE HORN KIT



- Mounts to any bridge with predrilled holes
- Keeps cables from leaving the cable pathway.
- Available in black plastic

	WEIGHT		BL
	LBS	KG	
BH75KIT	0.22	0.10	944722

INSERTPP PLASTIC INSERTS

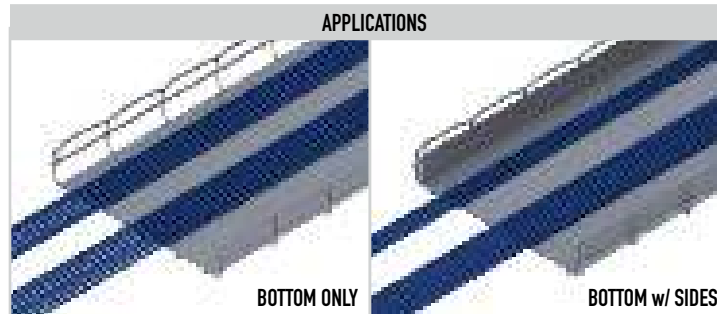

- 17 mil thickness creates a smooth cable pathway in Cablofil cable management
- Bottom only insert fits 150 to 600 wide tray
- Bottom with sides insert fits CF54, CF105 and CF150 tray in widths from 100 to 600
- Bottom with sides insert is perforated to easily form sides
- Flame Class per UL 94 V-0
- RoHS Compliant
- UV Retardant
- Other sizes available upon request

	TRAY WIDTH		HEIGHT		LENGTH		WEIGHT		BL
	INCHES	MM	INCHES	MM	FEET	M	LBS	KG	
BOTTOM ONLY									
INSERTPP150	6	150	-	-	200	60	7.1	3.22	944695
INSERTPP300	12	300	-	-	200	60	21.1	9.57	944696
INSERTPP450	18	450	-	-	200	60	33	14.96	944697
INSERTPP500	20	500	-	-	200	60	36.7	16.64	944691
INSERTPP600	24	600	-	-	200	60	44.1	20	944698
BOTTOM w/ SIDES									
INSERTPP105/150	6	150	4	105	165	50	21.2	9.61	944702
INSERTPP105/300	12	300	4	105	165	50	28.1	9.62	944703
INSERTPP105/450	18	450	4	105	165	50	45.5	20.63	944709
INSERTPP105/600	24	600	4	105	165	50	54.7	24.81	944700



OTDOFAS
OVER-THE-TOP DROP OUT

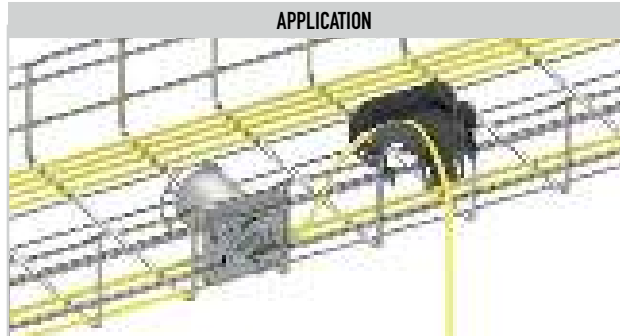

- Smooth, curved design keeps eliminates sharp bends for fiber-optic cabling
- Durable polycarbonate material
- Use built-in hold down slots for securing cables
- Snaps in place without additional hardware
- Allows cable to exit side of cable pathway without cutting tray wires
- Fits CF54/200-600 trays and CF105/150-600 trays
- Patent pending

	PKG. QTY.	WEIGHT		PL*
		LBS	KG	
OTDOFAS	1	.066	.029	943 779

*PL = Plastic

OTDO
OVER-THE-TOP WATERFALL

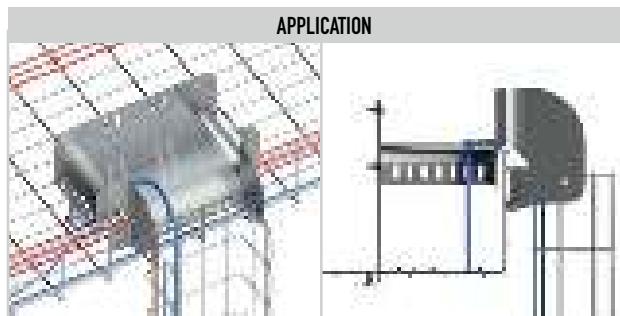

- Recommended for larger bundles of fiber-optic cabling dropouts
- Allows cable to exit side of cable pathway without cutting tray wires
- Metal construction available in Electro zinc and Black powder coated finishes
- Available in four sizes
- Kit includes one OTDO and all necessary mounting hardware
- Fits series 54, 105 and 150 Cablofil cable management
- Patent pending

	OPENING 1		OPENING 2		WEIGHT		EZ	BL
	INCHES	MM	INCHES	MM	LBS	KG		
OTD044	4	100	4	100	4.02	1.82	944 681	944 793
OTD046	4	100	6	150	4.72	2.14	944 791	944 795
OTD068	6	150	8	200	5.34	2.42	944 684	944 727
OTD0810	8	200	10	250	6.12	2.77	944 715	944 719

FIBER-OPTIC
A.64

CABLEXIT50 CABLE EXIT

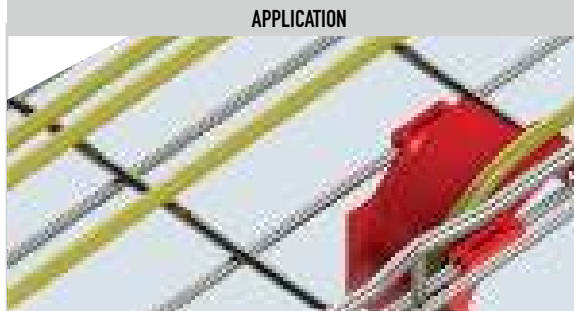

- Recommended for electrical, telecommunication and fiber-optic cabling
- Keeps cables from deforming when entering and exiting tray
- Plastic construction is durable and corrosion resistant
- Snaps into place without attachment hardware
- CABLEXIT can be installed in a continuous row without modification
- Fits any Cablofil cable management tray
- UL 94V0 Rated

	PKG. QTY.	WIDTH		LENGTH		WEIGHT		PL*
		INCHES	MM	INCHES	MM	LBS	KG	
CABLEXIT50	1	2	50	4	100	.024	.010	944 653

*PL = Plastic

TOH FIBER-OPTIC TWIST-ON HORN

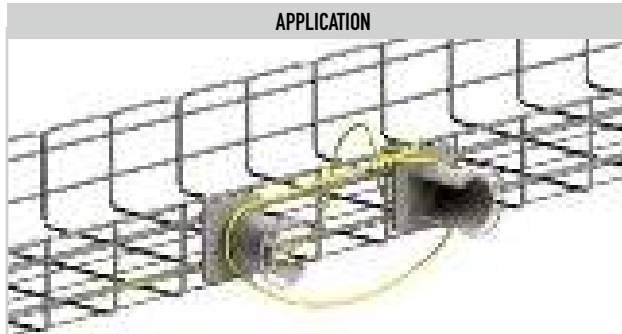

- Use to manage extra lengths of fiber-optic cabling
- Snaps onto side or bottom of any Cablofil cable pathway
- Use in singles, pairs or more
- ABS plastic construction is durable and corrosion resistant
- Kit includes one Plexo 80 Base and one Fiber-Optic Horn
- Requires no additional hardware for attachment

	PKG. QTY.	WEIGHT		PL*
		LBS	KG	
TOH	1	.13	.05	944 707

*PL = Plastic



OTHER MOUNTINGS



A wide variety of mounting accessories make Cablofil the easiest brand of Cable Management to install on the market. Every accessory has been designed to keep cables safe and create a durable installation.

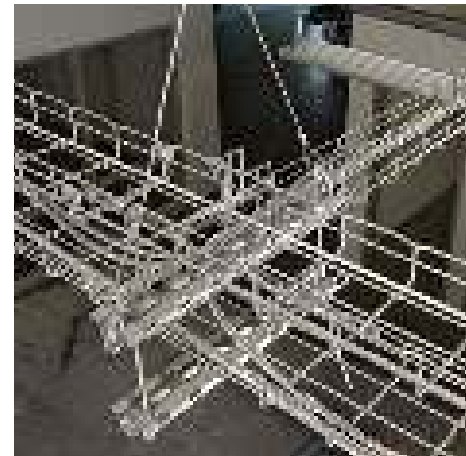

A.67 C50CC
CONDUIT CLAMP KIT

A.67 CC KIT
CONDUIT CLAMP KIT

A.68 CE40CC & CH
CONDUIT ATTACHMENT FITTINGS & CONDUIT CLAMP KIT

A.68 TC4KIT/TC5KIT
TWIST-ON METALLIC JUNCTION BOXES

A.69 C 50
ELECTRICAL BOX SUPPORT

A.69 SBDA
CONDUIT AND BOX SUPPORT

A.69 CM50I
INDUSTRIAL BOX MOUNTING BRACKET

A.70 HB 2 KIT
WALL/FLOOR TERMINATION BRACKET

A.70 AB225 KIT
ANGLE BRACKET

A.71 YCKIT
YOKE CLAMP KIT

A.71 WMC2LA
TRAY-TO-LADDER CLAMP

A.71 FS 41
FASTRUT CONNECTOR

A.72 DO
WATERFALL DROPOUT

A.72 CABLEXIT
DROP OUT KIT
CABLE DROP OUT

A.73 DROP OUT KIT
CABLE DROP OUT KIT

A.73 MFM
METALLIC MULTIFIX PLATE

A.74 CLIP
CABLE LABEL CLIP

A.74 EZVC
VELCRO ROLL

A.74 RB112KIT
RACK BRACKET KIT

A.75 EZJB 5/16
J-BOLT

A.75 GNDSB
GROUNDING LUG

A.75 GNDCL
GROUNDING LUG

A.76 FAS ROLLER

A.76 FAS ROLLER HD
HEAVY DUTY

A.78 FLAMESTOPPER

C50CC CONDUIT CLAMP KIT

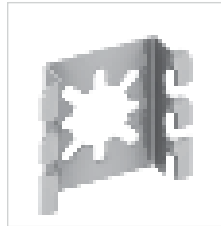
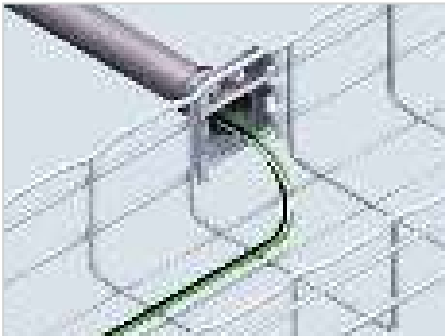

- Secures 1/2" to 1-1/2" conduit to any size Cablofil tray.
- Installs quickly – patented FAS locking tabs require no additional hardware to secure to tray.
- Attach conduit to C50CC after attachment to tray with conduit connector (not included).

	PKG QTY	WIDTH		CONDUIT DIAMETER		WEIGHT		PG	PG
		WIDTH		CONDUIT DIAMETER		LBS	KG		
		INCHES	MM	INCHES	MM				
C50CC12	1	0.82	20.8	0.5	12.7	0.21	0.10	943 175	75
C50CC34	1	1.04	26.4	0.75	19.0	0.21	0.10	943 176	76
C50CC1	1	1.29	32.8	1.0	25.4	0.20	0.09	943 115	15
C50CC114	1	1.64	41.6	1.25	31.7	0.20	0.09	943 116	16
C50CC112	1	1.88	47.2	1.5	38.1	0.20	0.09	943 117	17

CC KIT CONDUIT CLAMP KIT

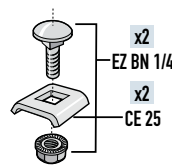
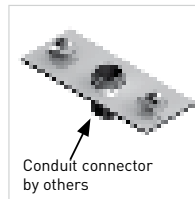
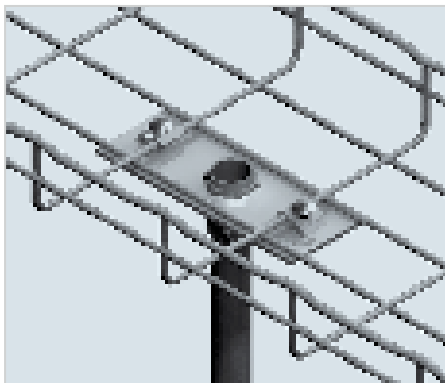

- Allows for easy connection to cable drops in EMT with conduit connector (not included).
- Attaches 1/2" to 4" conduit to any size Cablofil tray.
- Kit includes: one connector plate, two CE 25 washers and two EZ BN 1/4 Bolt/Nut.
- Remove one longitudinal wire (between adjacent cross wires of WMCT) on CCKITs 112 and larger where necessary on WMCT to accommodate conduit fittings clearance.

	EMT DIAMETER		WEIGHT		LOAD RATING		PG
	INCHES	MM	LBS	KG	LBS	KG	
CC12KIT	0.5	12.7	0.55	0.25	150.0	68.0	943 238
CC34KIT	0.75	19.0	0.55	0.25	150.0	68.0	943 239
CC1KIT	1.0	25.4	0.54	0.25	190.0	86.2	943 240
CC114KIT	1.25	31.7	0.53	0.24	225.0	102.1	943 241
CC112KIT	1.5	38.1	0.52	0.24	250.0	113.4	943 242
CC2KIT	2.0	50.8	0.51	0.23	300.0	136.1	943 243
CC212KIT	2.5	63.5	0.75	0.34	375.0	170.1	943 244
CC3KIT	3.0	76.0	0.75	0.34	500.0	226.8	943 245
CC312KIT	3.5	88.9	0.89	0.40	600.0	272.6	943 246
CC4KIT	4.0	101.0	1.0	0.47	700.0	317.5	943 247



CE40CC / CH CONDUIT ATTACHMENT FITTINGS AND CONDUIT CLAMP KIT

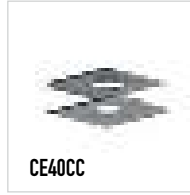
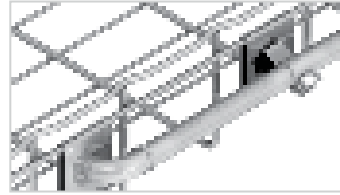

- Secures conduit to Cablofil tray.
- For Bottom Mounting – works with all Cablofil tray. For Side Mounting – works only with CF 105 and CF 150 tray series.
- CE 40 CC attaches 1/2" to 1-1/4" conduit diameters.
- CH Kit secures 1/2" to 4" conduit diameters.
- CH Kit includes: two CE 40 washers, one EZ BN 1/4 and one Conduit Hanger.

	PKG. QTY.	FOR CONDUIT SIZE	WEIGHT		EZ	BL	PE
			INCHES	LBS			
CE40CC12	10	0.5	0.22	0.10	943 168	–	–
CE40CC34	10	0.75	0.21	0.10	943 169	943 275	–
CE40CC1	10	1.0	0.20	0.09	943 170	943 276	–
CE40CC114	10	1.25	0.19	0.09	943 171	943 277	–
CH12 KIT	1	0.5	0.27	0.12	943 192	943 278	943 292
CH34 KIT	1	0.75	0.28	0.13	943 193	943 279	943 293
CH1 KIT	1	1.0	0.29	0.13	943 194	943 280	943 294
CH114 KIT	1	1.25	0.30	0.14	943 195	943 281	943 295
CH112 KIT	1	1.5	0.36	0.16	943 196	943 282	943 296
CH2 KIT	1	2.0	0.40	0.18	943 197	943 283	943 297
CH212 KIT	1	2.5	0.45	0.20	943 198	943 284	943 298
CH3 KIT	1	3.0	0.50	0.23	943 199	943 285	943 299
CH312 KIT	1	3.5	0.67	0.30	943 200	943 286	943 300
CH4 KIT	1	4.0	0.91	0.41	943 201	943 287	943 301

– Contact manufacturer for availability.

TC4KIT/TC5KIT TWIST-ON METALLIC JUNCTION BOXES

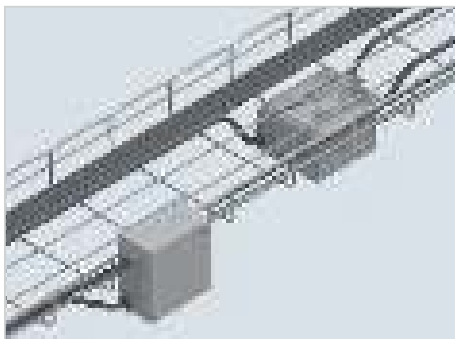

- Easy 45° twist-on attachment to any CF Series Cablofil tray.
- Available in 4" and 4-11/16" box sizes.
- Boxes feature standard knockouts on 4 sides.
- Flat covers, mounting screws, box and bonding hardware are included in kit.
- UL Classified.
- Designed to accept all NEMA standard face plates and plaster rings.

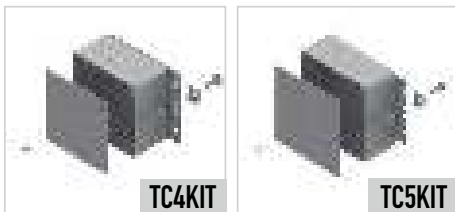

	HEIGHT		WIDTH		DEPTH		WEIGHT		PG
	INCHES	MM	INCHES	MM	INCHES	MM	LBS	KG	
TC4KIT	4.0	102	4.8	122	2.0	50	1.2	0.5	944 478
TC5KIT	4.7	119	5.5	140	2.0	50	1.3	0.5	944 479



C 50 ELECTRICAL BOX SUPPORT

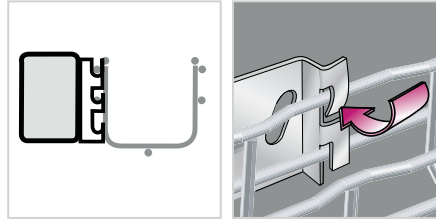
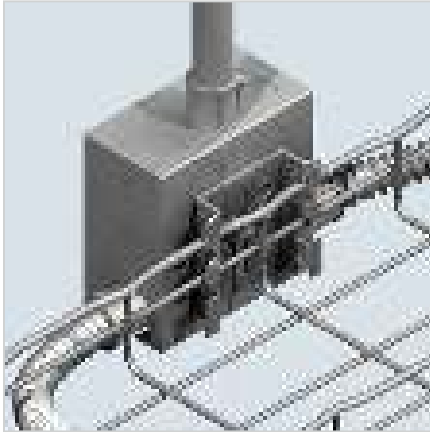

- Mount electrical boxes and lighting fixtures directly to cable tray.
- Slotted mounting holes allow for less-than-perfect hole alignment.
- Fold over tabs secure attachment to tray.

	WEIGHT		PG	GC	316L	BL	PE
	LBS	KG					
C 50	0.2	0.1	586 130	–	–	941 308	930 694

– Contact manufacturer for availability.

SBDA CONDUIT AND BOX SUPPORT

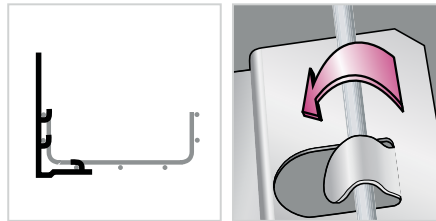
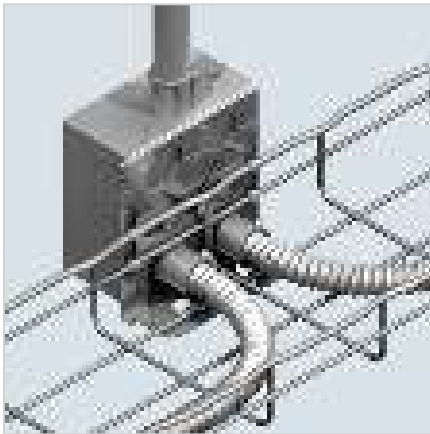

- Mount electrical boxes and conduit directly to Cablofil tray.
- Mounting holes accommodate 1/2" and 3/4" conduit.
- Slotted mounting holes allow for less-than-perfect hole alignment.
- Fold over tabs secure attachment to tray.

	WEIGHT		PG	316L	BL	PE
	LBS	KG				
SBDA	0.2	0.1	585 210	–	942 950	942 951

– Contact manufacturer for availability.

CM50I INDUSTRIAL BOX MOUNTING BRACKET

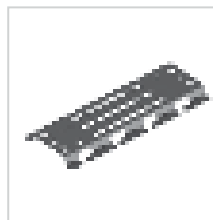
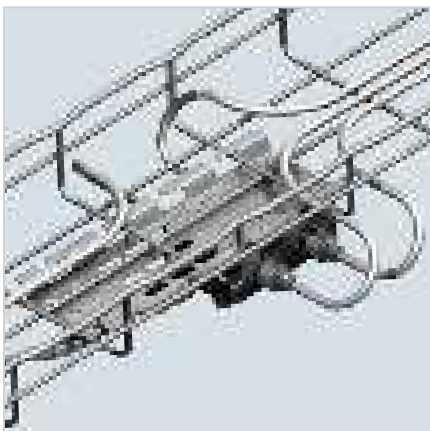

- FAS style tabs secures bracket to tray without additional hardware.
- Slotted mounting hole design allows for less-than-perfect hole alignment.

	WEIGHT		PG	GC	316L	BL
	LBS	KG				
CM50I	0.33	0.15	586 260	–	–	942 958

– Contact manufacturer for availability.



HB 2 KIT WALL/FLOOR TERMINATION BRACKET

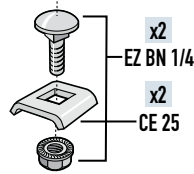
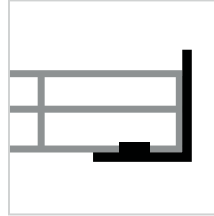
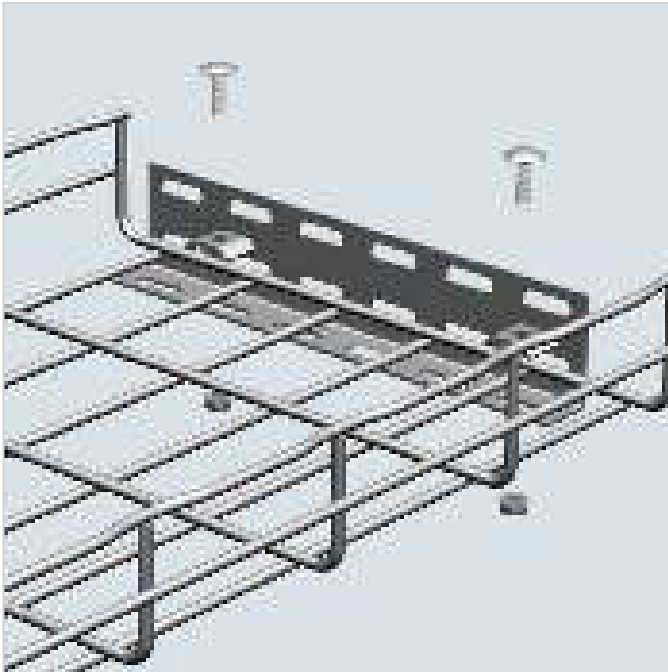

- Wall Termination Bracket works in a variety of ways to support Cablofil tray in telecommunications closets, equipment rooms, risers, etc. on wall or floor.
- Slotted design adapts to any configuration.
- Kit contains two EZ BN 1/4 and two CE 25 with one HB2.

	LENGTH		WEIGHT		PG	GC	316L	BL	PE
	INCHES	MM	LBS	KG					
HB 2 KIT	9.4	240	0.4	0.2	942 419	-	-	942 319	942 391

- Contact manufacturer for availability.

AB225 KIT ANGLE BRACKET

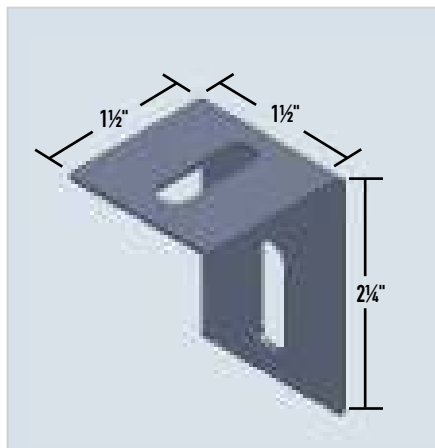
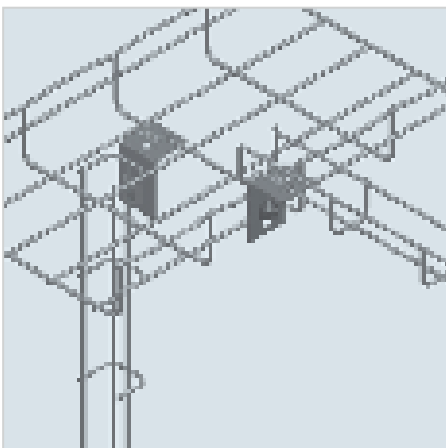

- Secures smaller tray runs to larger tray runs at right angles.
- Kit contains two EZ BN 1/4 Bolt/Nut and two CE 25 washers to secure tray.

	PKG. QTY.	WEIGHT		PG	316L
		LBS	KG		
AB225KIT	10	1.07	0.48	943 223	-

- Contact manufacturer for availability.

YCKIT
YOKE CLAMP KIT

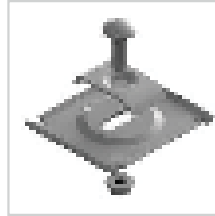

- Secures tubing to Cablofil tray to resist vibration in industrial applications.
- Accommodates up to 1/2" tubing.
- Each kit includes: one YC Yoke Clamp, one CE 40 Washer and one EZBN 1/4 Bolt/Nut.

	PKG. QTY.	NO. OF TUBES	TUBE DIAMETER		WEIGHT		316L
			INCHES	MM	LBS	KG	
YC214KIT	10	2	0.25	6.35	1.17	0.53	943 253
YC238KIT	10	2	0.375	9.52	1.20	0.54	943 254
YC212KIT	10	2	0.5	12.7	1.32	0.60	943 255
YC414KIT	10	4	0.25	6.35	1.34	0.61	943 256
YC438KIT	10	4	0.375	9.52	1.47	0.66	943 257

WMC2LA
WIRE MESH CABLE TRAY-TO-LADDER CLAMP



- This unique clamp allows tray to be attached to the side rails of any ladder tray and a pre-installed setscrew secures the junction for a secure installation.
- Bolt head protection cap included as shown

	PKG. QTY.	WEIGHT		GC	304L	BL	PE
		LBS	KG				
WMC2LA	1	0.37	0.17	-	-	943 493	943 494

- Contact manufacturer for availability.

FS 41
FASTRUT CONNECTOR

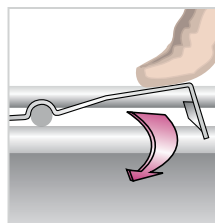
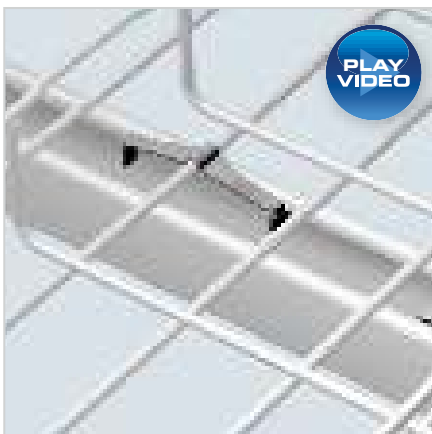

- FASTRUT attaches tray to strut without bolts and nuts or tools.
- Reduces installation time.
- Install FASTRUT on outer wires of tray, and both sides of the strut.
- 2 required for tray 12" or smaller.
- 3 required for tray 18" or larger.

	PKG. QTY.	WEIGHT		DC	316L	BL	PE
		LBS	KG				
FS 41	25	3.3	1.5	599 007	599 004	942 823	942 824



DO
WATERFALL DROPOUT

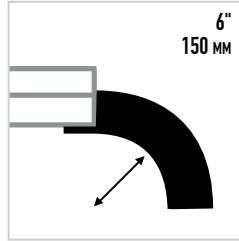
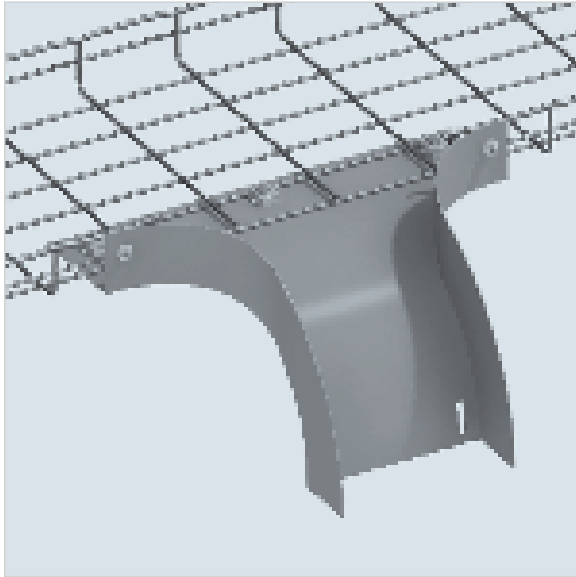

- Smooth solid construction provides protection for cables entering or exiting the cable pathway.
- Can be used as transition to other cable types.
- All attachment hardware is included.
- Upright flange support holes where required.
- Designed to fit 6" (150 mm) and wider trays.

	TRAY DEPTH		WIDTH*		WEIGHT		EZ	BL	PE
	INCHES	MM	INCHES	MM	LBS	KG			
DO54/150	2.0	54	6.75	170	13.2	6.0	943 210	943 258	943 262
DO54/300	2.0	54	12.75	325	17.6	8.0	943 211	943 259	943 263
DO105/150	4.0	105	6.75	170	15.4	7.0	943 212	943 260	943 264
DO105/300	4.0	105	12.75	325	19.8	9.0	943 213	943 261	943 265

*Internal dimensions

CABLEXIT
CABLE EXIT

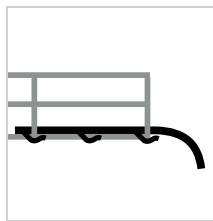
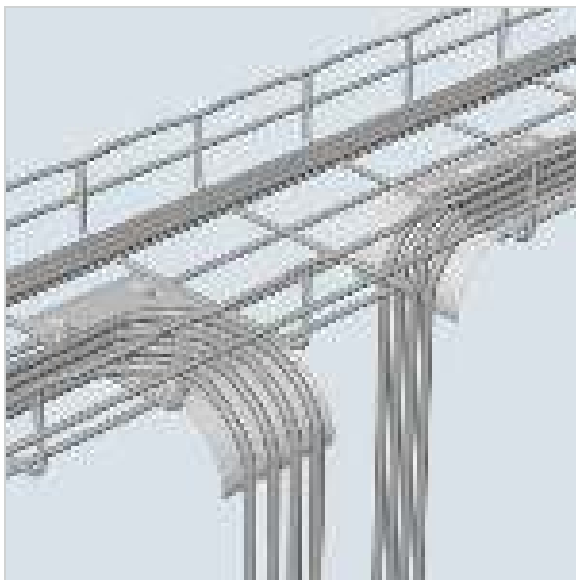

- Protects cables when exiting and entering tray.
- Snap in mounting tabs eliminate the need for attachment hardware and speeds install time.

	WEIGHT		PG	316L	BL	PE
	LBS	KG				
CABLEXIT100	0.2	0.1	585 160	585 164	941 299	930 669

DROP OUT KIT CABLE DROP OUT KIT

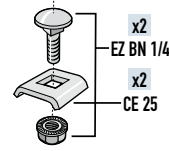
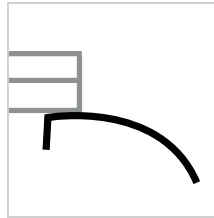
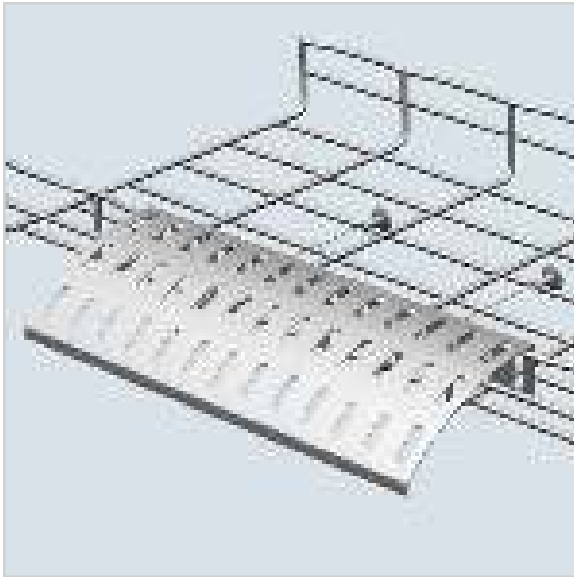

- Protects cables when exiting and entering tray. Slotted design allows for cable tie or velcro tiwrap cable attachment.
- 7" radius bend eases strain on cables.
- Kit contains two EZ BN 1/4 and two CE 25 with one DROP OUT.

	LENGTH		WEIGHT		PG	GC	316L	BL	PE
	INCHES	MM	LBS	KG					
DROP OUT KIT	12.25	311	0.9	0.4	942 895	–	–	942 896	942 898

– Contact manufacturer for availability.

MFM METALLIC MULTIFIX PLATE

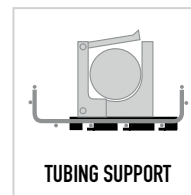
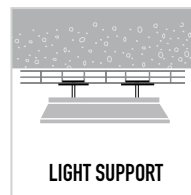
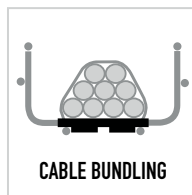
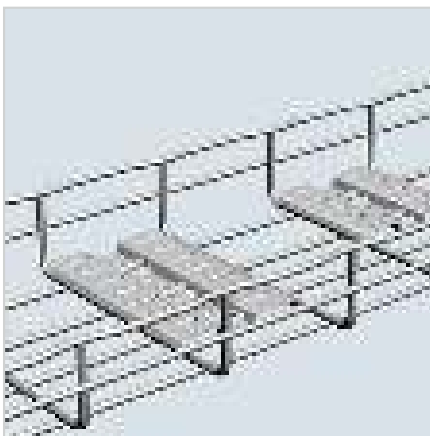

- Allows installer to mount junction boxes, lighting, tubing, cable bundles or other hardware directly to tray.
- Snap in mounting tabs eliminate the need for additional hardware and speed install time.
- Tubing clamps can be attached to plate.
- Underside load limit: 75 lbs (S.F. 1.5)

	LENGTH		WEIGHT		PG	GC	316L	BL	PE
	INCHES	MM	LBS	KG					
MFM 100	4.0	100	0.2	0.1	585 140	–	585 144	941 297	930 664
MFM 150	6.0	150	0.2	0.1	585 150	–	–	941 298	930 667

– Contact manufacturer for availability.



CLIP
CABLE LABEL CLIP

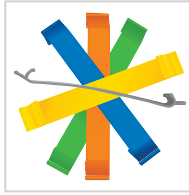
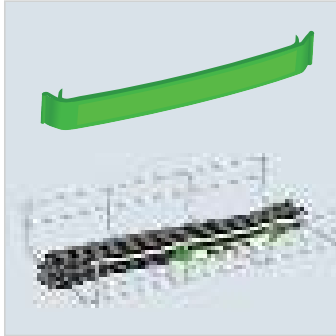

- Use Cable Label Clips to identify cable runs.
- Color code makes identification easy.
- Durable poly material won't fade.

	PKG. QTY.	COLOR	WEIGHT		PL*
			LBS	KG	
CLIPBLACK	50	Black	0.009	0.004	559 127
CLIPWHITE	50	White	0.009	0.004	559 137
CLIPORANGE	50	Orange	0.009	0.004	559 147
CLIPYELLOW	50	Yellow	0.009	0.004	559 157
CLIPGREEN	50	Green	0.009	0.004	559 167
CLIPBLUE	50	Blue	0.009	0.004	559 177
CLIPGRAY	50	Gray	0.009	0.004	559 197

*PL= Plastic

EZVC
VELCRO ROLL

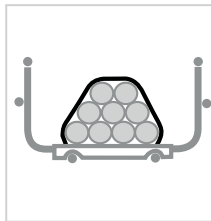
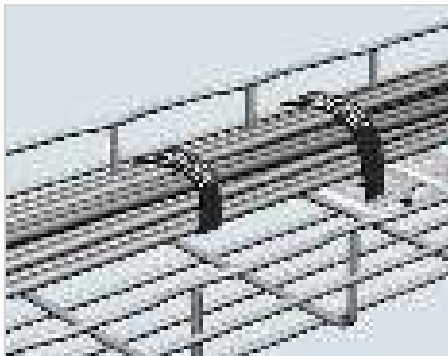

- 1/2" velcro can be cut to fit any size cable bundle.
- Great for frequent cable changes.

	LENGTH		WEIGHT		VC*
	FEET	MM	LBS	KG	
EZVC	15 / ROLL	7	0.1	0.05	559 677

*VC= Velcro

RB112KIT
RACK BRACKET

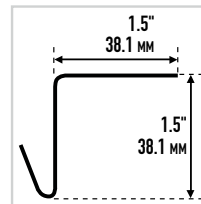

- Secures Cablofil tray to angled frame type rack tops.
- Tray can be attached parallel with the rack front.
- 10 Kits to a package.
- Works with all tray sizes.
- Each Kit includes:
 - (1) RB112 Bracket
 - (1) CE 40 washer
 - (1) EZ BN 1/4 Bolt/nut

	PKG. QTY.	WIDTH		DEPTH		WEIGHT		EZ
		INCHES	MM	INCHES	MM	LBS	KG	
RB112KIT	10	1.5	38	1.5	38	0.35	0.16	943 350

OTHER MOUNTINGS

EZJB 5/16 J-BOLT



- Use this J-Bolt in conjunction with a FAS P 200 or FAS P 300 for attachment to a 19" or 23" rack.
- No drilling needed (see drawing).
- FAS Profile sold separately.
- Nut included.

	PKG. QTY.	LENGTH		WEIGHT		EZ	GC	316L	BL	PE
		INCHES	MM	LBS	KG					
EZJB 5/16	2	2.5	64	2.0	0.91	942 016	-	-	942 311	942 383

- Contact manufacturer for availability.

GNDSB GROUNDING LUG



- Accommodates AWG 3-14 grounding wires.
- Use one GNDSB every 60' and/or at the end of each tray run. If tray is used as an Equipment Grounding Conductor, use one on each section of tray for a code compliant installation.
- Works with any size Cablofil tray.
- UL Listed, CSA Approved.

	WEIGHT		CU*
	LBS	KG	
GNDSB	0.07	0.03	942 616

*CU= Copper

GNDCB GROUNDING LUG



- Accommodates AWG 1/0 - #6 grounding wires.
- Use one GNDCB every 60' and/or at the end of each tray run. If tray is used as an Equipment Grounding Conductor, use one on each section of tray for a code compliant installation.
- Works with any size Cablofil tray.
- UL Listed, CSA approved.
- Tin-plated

	WEIGHT		CU*
	LBS	KG	
GNDCB	0.2	0.1	942 866

*CU= Copper



FAS ROLLER
CABLE GUIDE

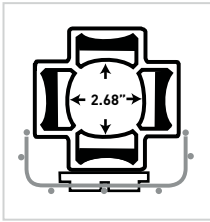
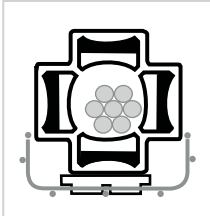

- Easy open gate allows full access to FAS Roller.
- Unique 4 roller design prevents cable snagging.
- Bi-color rollers show roller turn at a distance which prevents burning the cable while being pulled.
- Multifix™ poly swivel base attaches directly to Cablofil tray without tools.
- Can also be attached with bolts or handy clamp provided in kit.
- Use FAS Roller as a permanent part of a tray installation in horizontal and vertical pathways – for hard to reach areas, i.e. access floors or plenums.
- Sold in sets of 6 – includes handy carrying case.
- Inside diameter is 2.688”.

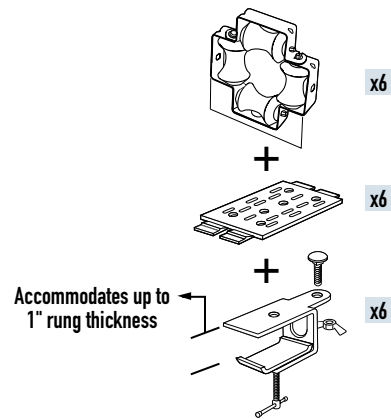

	PKG. QTY.	WEIGHT		PL*
		LBS	KG	
FAS ROLLER	6	11.0	4.8	011 100

*PL= Plastic

APPLICATIONS

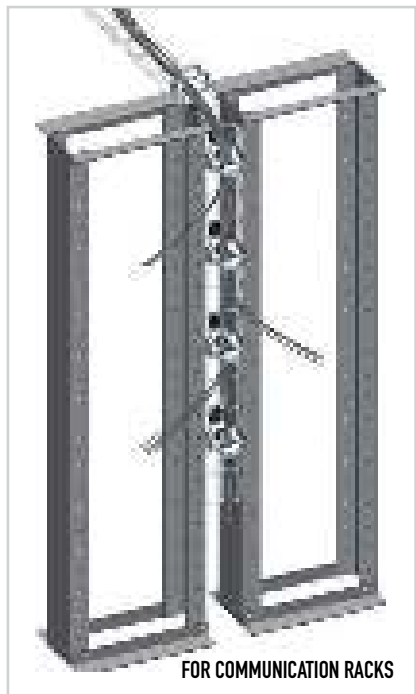
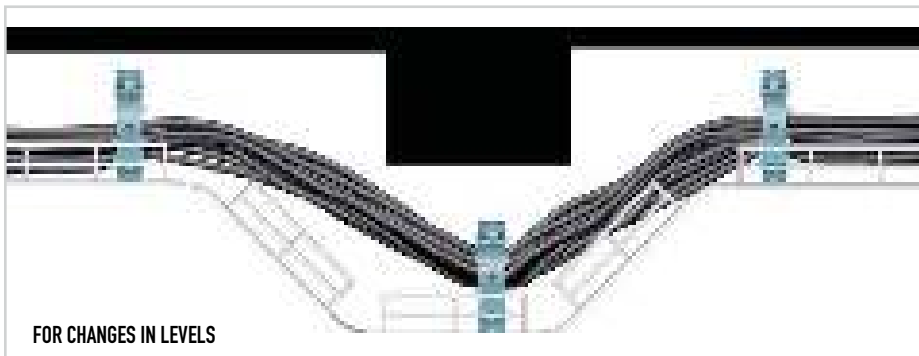

OTHER MOUNTINGS

FASROLLER HD HEAVY DUTY

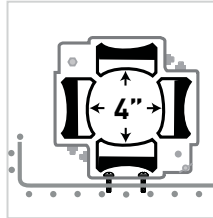
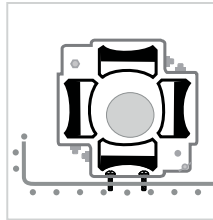
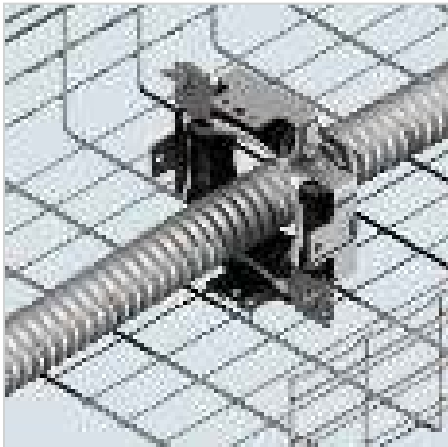

- Use HD FAS Roller to pull large power cables or MC cables.
- Heavy-duty frame attaches to any Cablofil tray with EZ BN 1/4 and CE 30.
- Swing-open gate allows easy loading and unloading of cables.
- 4-roller design allows cables to be pulled in any direction - prevents cable snags.
- Bi-colored rollers show installer that roller is functioning properly - prevents burned cable insulation.
- Sold individually.
- Always place hinge side to inside radius when used on fittings.
- Inside diameter is 4".



	WEIGHT		PG
	LBS	KG	
FAS ROLLER HD	3.5	1.59	942 879

APPLICATIONS

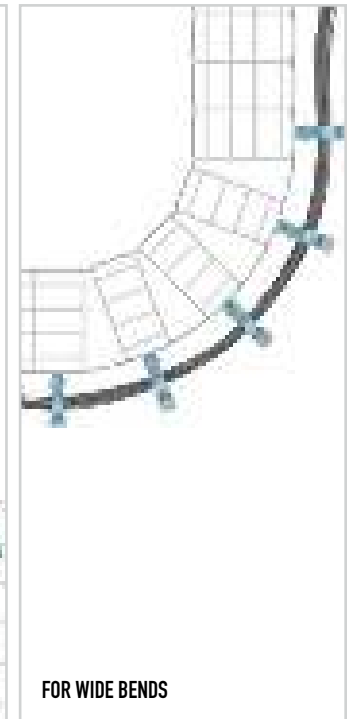
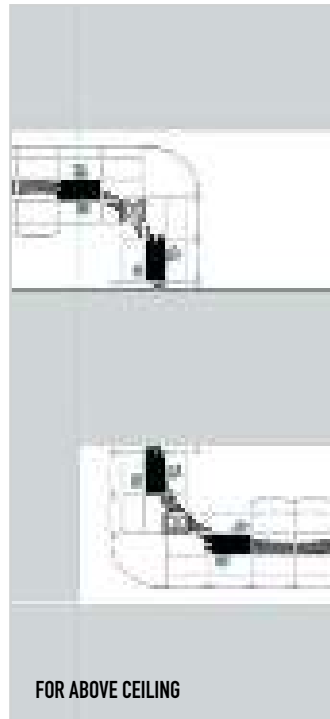
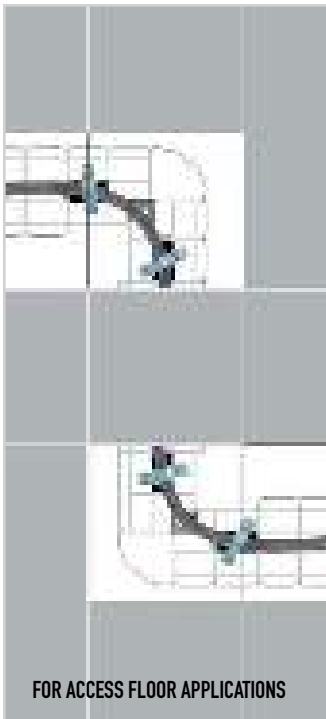

FLAMESTOPPER™

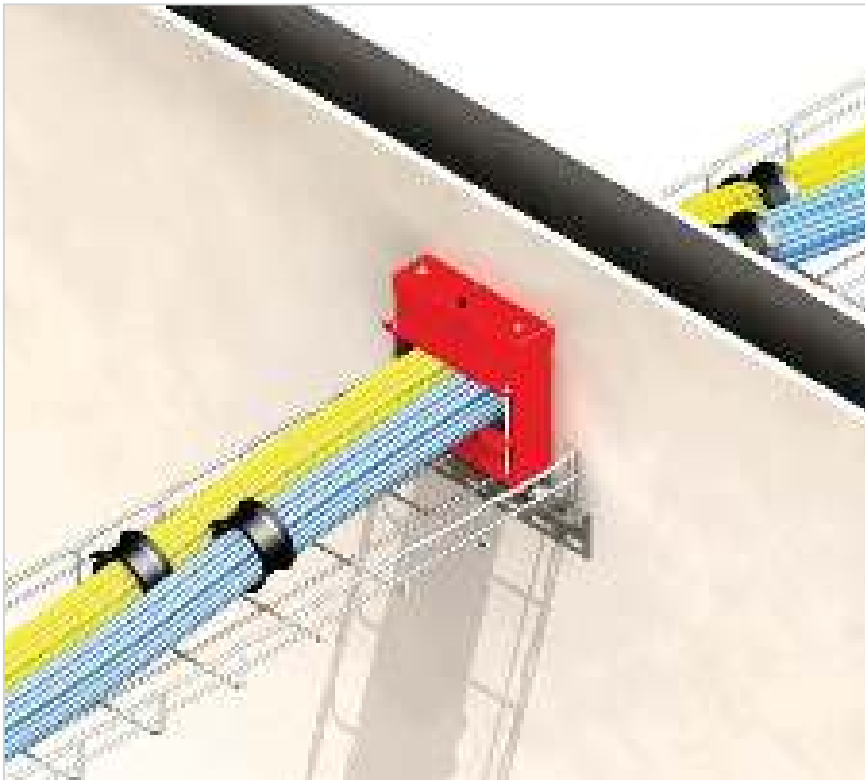

If you need the integrity of a firewall, without adding caulk or putty after the cables have been installed, look to FlameStopper thru-wall fittings. Redesigned for both new installations and retrofits, these fittings combine a built-in fire-stopping intumescent material with an enclosed thru-wall penetration. They meet UL tests for flame, temperature and smoke, as well as for use in air handling spaces (plenums). Once installed, FlameStopper fittings allow you to add or remove cables easily, without risking unseen and potentially dangerous gaps or voids that can occur with caulks or putty.

FlameStopper thru-wall fittings consist of two box assemblies, each with adjustable steel doors. The boxes are fitted to EMT conduit and cable pass through a block of intumescent material inside each assembly. At 375° the material expands, creating a hard char that fills voids around the cables and stops flame from penetrating the opening. FlameStopper thru-wall fittings are easy to install and inspect and work seamlessly with Cablofil cable management.

- Available in 2" and 4" capacities.
- 4 hour rating for flame and temperature when tested to UL 1479 standards.
- Highly effective smoke stop.
- Can be ganged for additional capacity.
- Bond both FlameStopper Fittings and Cablofil Trays together by attaching proper size wire to ground screw on fitting tops, through FlameStopper Sleeve, and to trays using either Cablofil GNDSB or GNDCL ground clamp in order to comply with NEC 250.96

TO INSTALL FLAMESTOPPER



1 Determine the location for the fitting on the wall and cut a hole to fit FlameStopper EMT conduit.



2 Install FlameStopper box to one side of the wall using adhesive strips. Insert the proper length of conduit thru the opening and press in place.



3 Install the second FlameStopper box to opposite side of the wall and tighten all bolts.

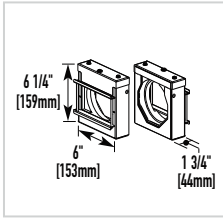

Firestop 4" Trade EMT Conduit Fitting –

For transitioning cable through fire rated walls/floors for both new and retrofit applications. Available in red (RED), or G90 galvanized finish (GA). UL System W-L-3264 and W-J-3137.

	HEIGHT		WIDTH		DEPTH		RED	GA
	INCHES	MM	INCHES	MM	INCHES	MM		
FS4R	6.25	159	6.0	153	1.75	44	FS4R-RED	RS4R-GA

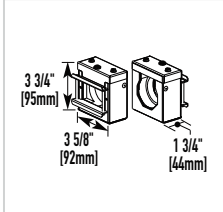

Firestop 2" Trade EMT Conduit Fitting –

For transitioning cable through fire rated walls/floors for both new and retrofit applications. Available in red (RED), or G90 galvanized finish (GA). UL System W-L-3264 and W-J-3137.

	HEIGHT		WIDTH		DEPTH		RED	GA
	INCHES	MM	INCHES	MM	INCHES	MM		
FS2R	3.75	95	3.625	92	1.75	44	FS2R-RED	RS2R-GA

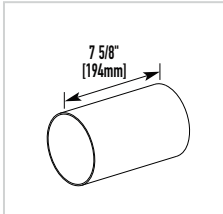

Precut Conduit 4" Trade Size EMT –

Precut to 7 5/8" [194mm] to fit standard gypsum fire walls with a two-hour fire rating (6" [152mm] wall thickness).

	LENGTH	
	INCHES	MM
FSPCC4758	7.625	194

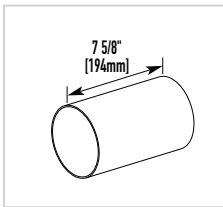

Precut Conduit 2" Trade Size EMT –

Precut to 7 5/8" [194mm] to fit standard gypsum fire walls with a two-hour fire rating (6" [152mm] wall thickness).

	LENGTH	
	INCHES	MM
FSPCC2758	7.625	194

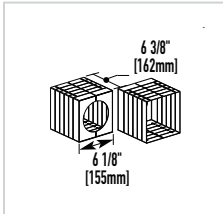

Heat Shield 4" Trade Size Conduit –

Used only when an existing installed conduit extends 1" [25mm] to 6" [152mm] beyond the wall surface.

	WIDTH		DEPTH	
	INCHES	MM	INCHES	MM
FS4RHS	6.125	155	6.375	162

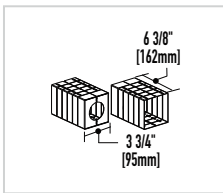

Heat Shield 2" Trade Size Conduit –

Used only when an existing installed conduit extends 1" [25mm] to 6" [152mm] beyond the wall surface.

	WIDTH		DEPTH	
	INCHES	MM	INCHES	MM
FS2RHS	3.75	95	6.375	162

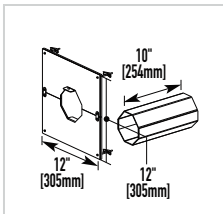

Retrofit Kit for Existing Installations –

Kit includes 4" trade size split conduit sleeve to enclose existing cables, and 12" x 12" [305mm x 305mm] ceramic heat protected wall plate to cover irregular hole cuts. For use with FS4R Series Firestop.

	HEIGHT		WIDTH		DEPTH	
	INCHES	MM	INCHES	MM	INCHES	MM
FS4RWP12	12.0	305	12.0	305	10.0	254

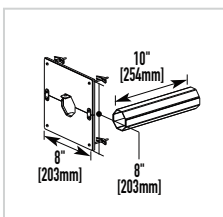

Retrofit Kit for Existing Installations –

Kit includes 2" trade size split conduit sleeve to enclose existing cables, and 8" x 8" [203mm x 203mm] ceramic heat protected wall plate to cover irregular hole cuts. For use with FS2R Series Firestop.

	HEIGHT		WIDTH		DEPTH	
	INCHES	MM	INCHES	MM	INCHES	MM
FS4RWP8	8.0	203	8.0	203	10.0	254



ACCESSORIES



ED 275

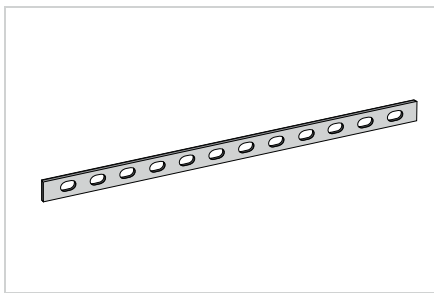

ED 1100

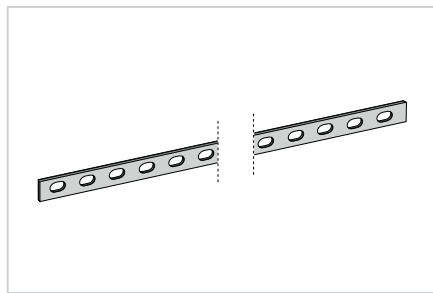

ED 250/90

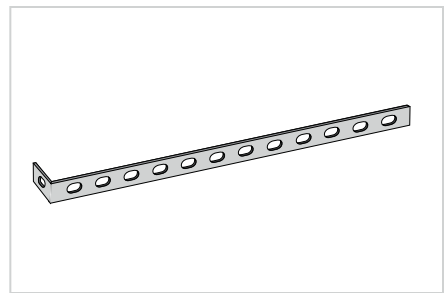

	PKG. QTY.	LENGTH		WEIGHT		EZ	316L	BL	PE
		INCHES	MM	LBS	KG				
ED 275	50	11.0	275	14.3	6.5	558 221	558 224	941 279	930 621
ED 1100	1	43.0	1100	1.1	0.5	558 201	—	941 277	930 616
ED 250/90	50	10.0	250	14.3	6.5	558 211	—	941 278	930 618

— Contact manufacturer for availability.

CE 25

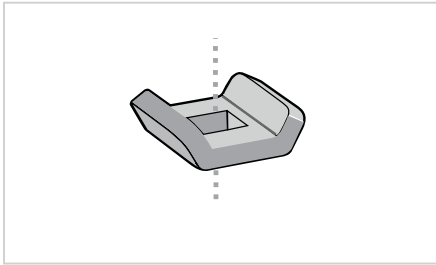

CE 30

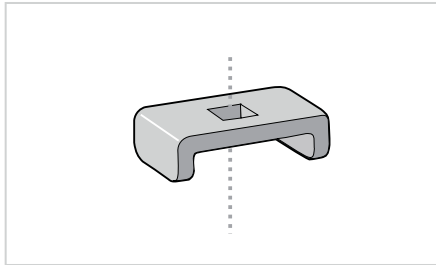

CE 35



CE 40

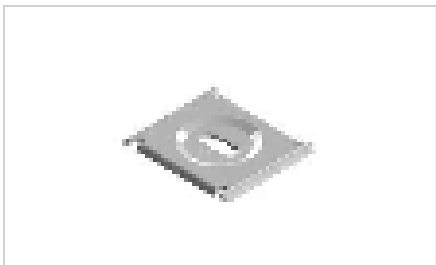

**EZ BN 1/4
EZ BN 5/16**

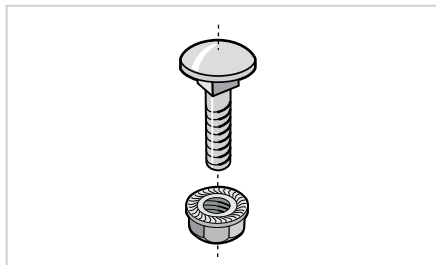

SWK

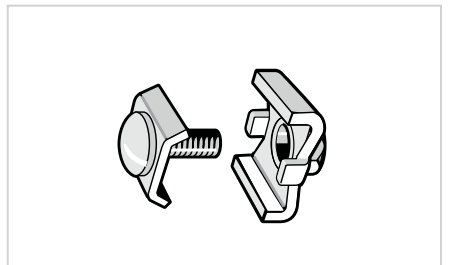

	PKG. QTY.	WEIGHT		EZ	GC	DC	316L	BL	PE
		LBS	KG						
CE 25	50	1.0	0.4	558 011	-	-	-	941 274	934 022
CE 30	50	1.7	0.8	558 041	-	-	-	941 275	934 028
CE 35	25	1.1	0.5	-	-	-	-	-	-
CE 40	25	2.7	1.2	558 051	-	-	-	941 276	934 030
EZ BN 1/4	50	1.3	0.6	941 084	-	943 458	-	942 308	942 380
EZ BN 5/16	50	2.0	0.9	942 778	-	943 500	-	942 780	-
SWK	50	3.6	1.6	943 215	-	943 216	943 218	943 217	-

- Contact manufacturer for availability.

CA

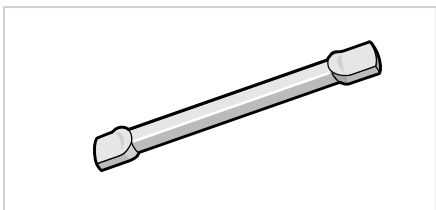

ECLI

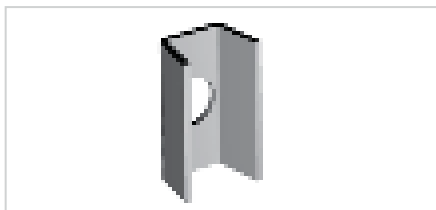

FASLOCK

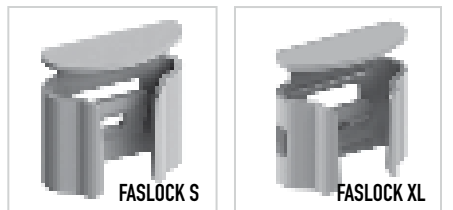

	PKG. QTY.	WEIGHT		PG	EZ	GC	DC	316L	BL	PE
		LBS	KG							
CA	50	2.2	1.0	-	801 051	-	-	-	942 881	-
ECLI	10	0.04	0.02	557 190	-	-	-	-	942 797	-
FASLOCK S*	25	1.4	0.6	-	558 340	-	-	-	942 869	942 870
FASLOCK XL*	25	1.4	0.6	-	558 320	-	-	-	942 821	942 822

- Contact manufacturer for availability.

*Use FASLOCK S for 100mm - 200mm. Use FASLOCK XL for 300mm - 600mm.



INSTALLATIONS

A.83 CUSTOM BENDS AND JUNCTIONS
DIRECTIONAL CHANGE
HARDWARE

A.84 HOW TO CUT CABLOFIL CABLE TRAY
COUPFIL
CUTYFIL

A.85 USING A POWER CUTTER TO CUT CABLOFIL

A.86 EDRN
FAST SPLICE

A.86 PRECLICK
SPLICE

A.87 FAS TABS FOR SUPPORTS

A.87 FAS TABS FOR ACCESSORIES

A.88 T JUNCTIONS
RAD T 90 KIT

A.90 T JUNCTIONS
EZ T 90 KIT

A.92 Y JUNCTIONS

A.94 90° BENDS
RAD T 90 KIT

A.96 90° BENDS
EZ T 90 KIT

A.98 90° JUNCTIONS
EZ T 90 KIT

A.99 OTHER THAN 90° JUNCTIONS

A.100 SWEEPS
SWK

A.102 SWEEPS
FASLOCK

A.104 REDUCTIONS

A.107 CHANGING LEVELS
CUTTING AND BENDING

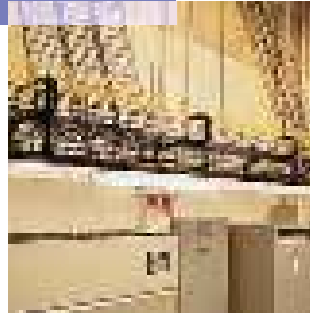

Use this guide to learn the most effective installation practices when installing Cablofil tray. Each example of bends and tee's clearly illustrate proper tray cutting combined with recommended usage of Cablofil accessories.



CUSTOM BENDS AND JUNCTIONS

WITH CABLOFIL CABLE TRAY, ANY INSTALLATION CONFIGURATION IS POSSIBLE

Engineers and contractors in North America and around the world have found Cablofil to be the solution to any installation problem. Any bend, sweep or level change can be fabricated on site. Let your imagination have no limits on your next project.

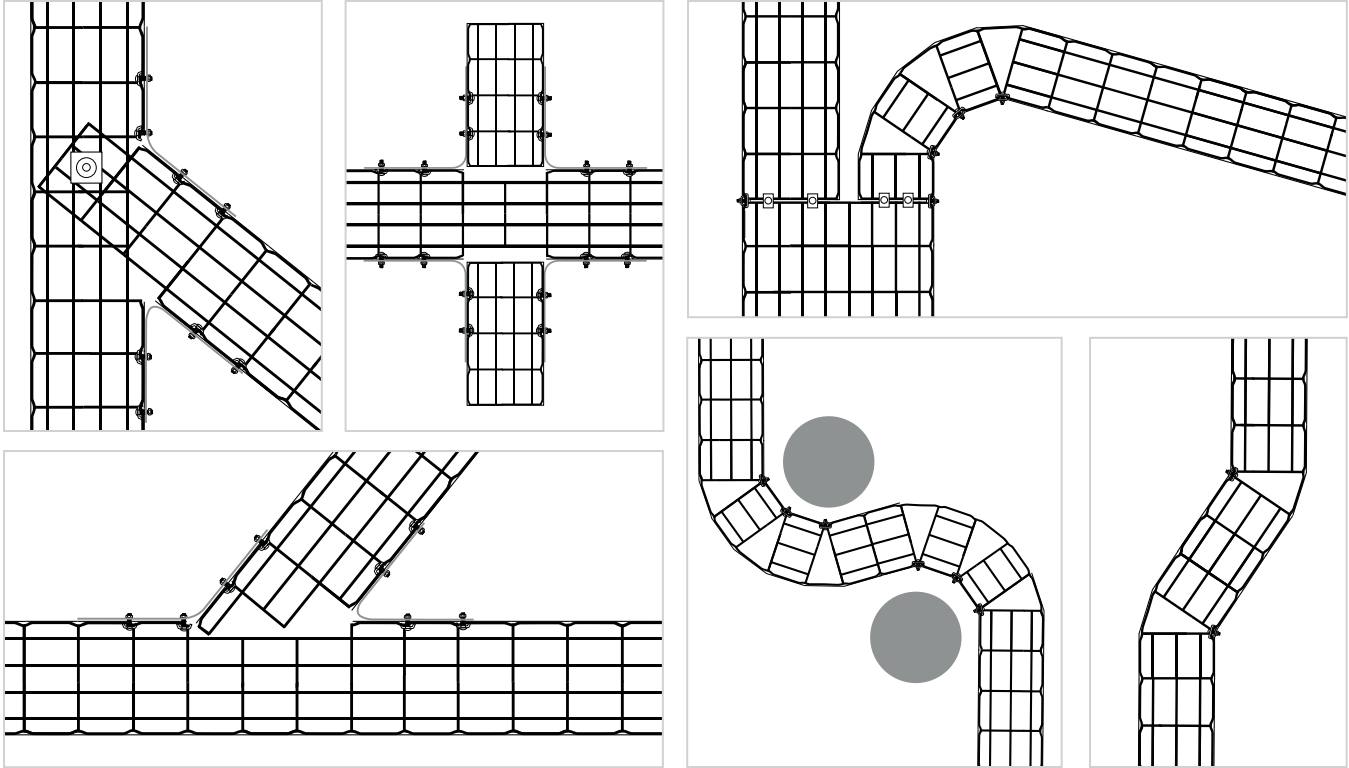

DIRECTIONAL CHANGE HARDWARE

		90° BENDS								HORIZONTAL TEE					
		FASLOCK (SWEEP)		SWK (SWEEP)		RADT90		EZT90		RADT90		EZT90		Y JUNCTION	
TRAY WIDTH		QTY. REQUIRED	CUT INSTRUCTIONS	QTY. REQUIRED	CUT INSTRUCTIONS	QTY. REQUIRED	CUT INSTRUCTIONS	QTY. REQUIRED	CUT INSTRUCTIONS	QTY. REQUIRED	CUT INSTRUCTIONS	QTY. REQUIRED	CUT INSTRUCTIONS	HARDWARE REQUIRED	CUT INSTRUCTIONS
INCHES	MM														
2.0	50	-	-	2	p. A.100	-	-	1 kit	p. A.96	-	-	1 kit	p. A.90	-	-
4.0	100	2	p. A.102	2	p. A.100	1 kit	p. A.88	1 kit	p. A.96	1 kit	p. A.94	1 kit	p. A.90	p. A.80-81	p. A.92
6.0	150	3	p. A.102	4	p. A.100	1 kit	p. A.88	1 kit	p. A.96	1 kit	p. A.94	1 kit	p. A.90	p. A.80-81	p. A.92
8.0	200	4	p. A.102	4	p. A.100	1 kit	p. A.88	1 kit	p. A.96	1 kit	p. A.94	1 kit	p. A.90	p. A.80-81	p. A.92
12.0	300	6	p. A.103	6	p. A.101	1 kit	p. A.89	1 kit	p. A.97	1 kit	p. A.94	1 kit	p. A.91	p. A.80-81	p. A.93
18.0	400	9	p. A.103	8	p. A.101	1 kit	p. A.89	1 kit	p. A.97	1 kit	p. A.95	1 kit	p. A.91	p. A.80-81	p. A.93
20.0	450	10	p. A.103	9	p. A.101	1 kit	p. A.89	1 kit	p. A.97	1 kit	p. A.95	1 kit	p. A.91	-	-
24.0	550	12	p. A.103	11	p. A.101	1 kit	p. A.89	1 kit	p. A.97	1 kit	p. A.95	1 kit	p. A.91	-	-



HOW TO CUT CABLOFIL CABLE TRAY

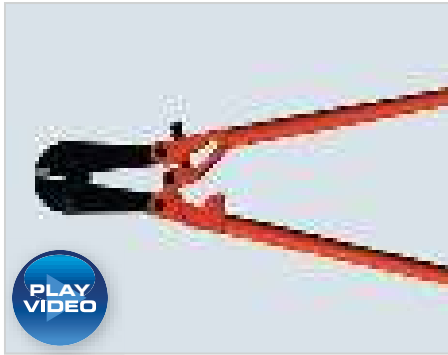

	LENGTH		WEIGHT		
	INCHES	MM	LBS	KG/1	
COUPFIL	24.8	630	6.0	2.7	559 507

- Always use side action angle bolt cutters.

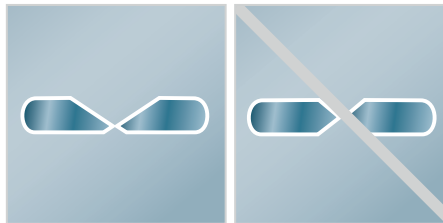
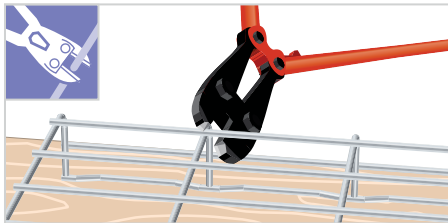

- Angle all cuts away from the new end.
- Cut each wire with one clean cut, eliminating any grinding or touch-up.

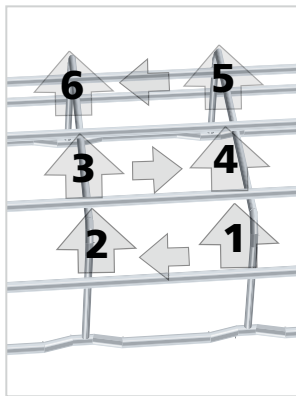
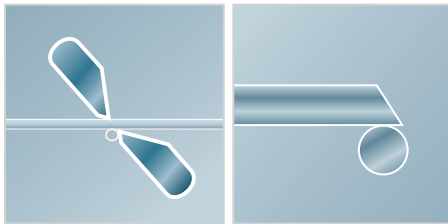

- Cut the bottom wires first, in order as shown, from the underside of the tray.
- Rest the lower jaw of the cutters against the cradle wire and cut at an angle away from the new end.



- Cut the side wires next, starting with the top wire.
- Make sure the finished cut is safe and ready for installation.

USING A POWER CUTTER TO CUT CABLOFIL



cutyfil

Cutyfil makes cutting Cablofil cable management easy. This lightweight power tool features a 330° swivel cutting head to make cuts from any angle. One button control engages and retracts blade for each cut. Cutyfil Kit comes in a padded carrying case with 2 batteries and a charger.

Go to www.legrand.us/cablofil to view video demonstration.

WEIGHT

	LBS	KG/1	
CUTYFIL	9.5	4.3	559 548
REPLACEMENT BLADES	0.4	0.2	559 577
BATTERY	1.0	0.5	559 567
CHARGER	2.0	0.9	559 558



Use the same cutting procedures as outlined on the previous page when using Cutyfil. Remember to always wear safety goggles and follow safe procedures when using power equipment.



EDRN FAST SPLICE

SPLICING GUIDELINES

CF30 – CF54 – CF105 – CF150	2" → 8" (50 → 200 mm)	12" (300 mm)	18" → 24" (450 → 600 mm)
 EDRN splices needed on side wires	2x EDRN	2x EDRN	2x EDRN
 EDRN splices needed on bottom of tray	–	1x EDRN	2x EDRN

INSTRUCTIONS

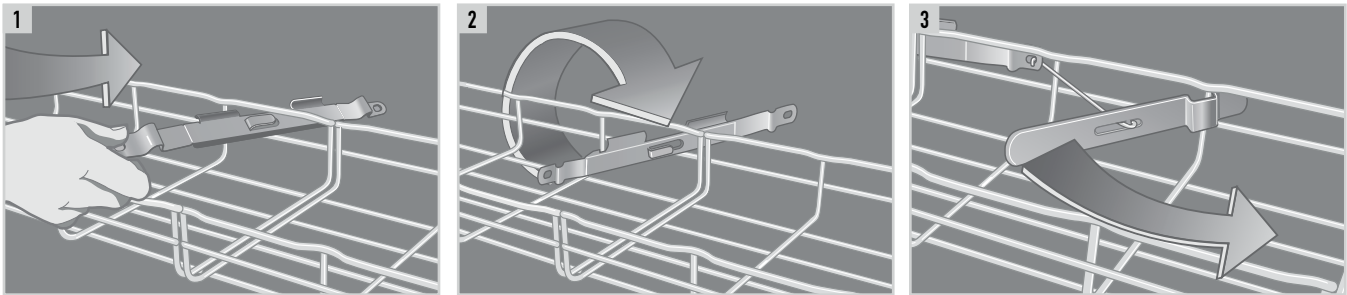

PRECLICK SPLICE

SPLICING GUIDELINES

CF54 – CF105 – CF150	2" → 8" (50 → 200 mm)	12" (300 mm)	18" → 24" (450 → 600 mm)
 PRECLICK splices needed on side wires	2x PRECLICK	2x PRECLICK	2x PRECLICK
 SWK splices needed on bottom of tray	–	1x SWK	2x SWK

INSTRUCTIONS

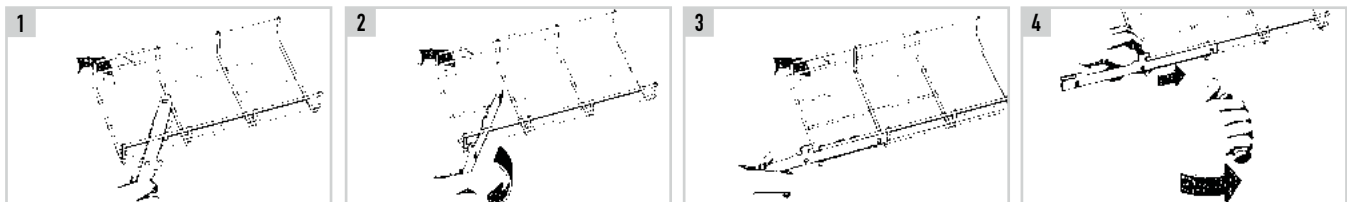

Step 1-3: Snap a PRECLICK on each length of Cablofil tray to be joined.

Step 4: Snap in place with a screw driver or a simple "TAP" on the end.

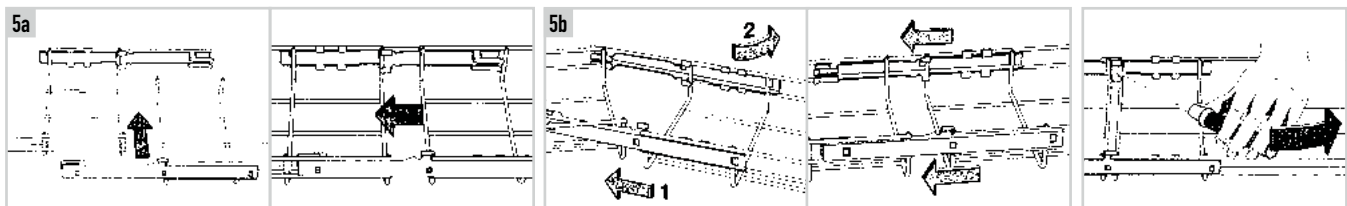

Step 5: Join both lengths of Cablofil tray and snap in place. (two options)

Removing PRECLICK: Use a screw driver to remove PRECLICK

PROPER USE OF FAS TABS

FAS tabs speed up installation times and because no additional attachment hardware is required, they also reduce costs. Follow these steps for proper installation:

FOR SUPPORTS

INSTRUCTIONS

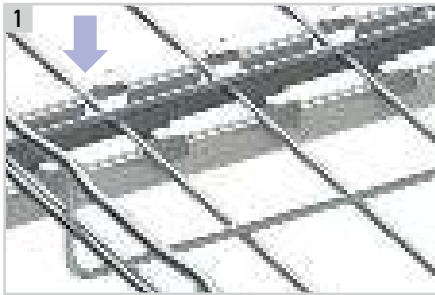

1 Insert tray into slots

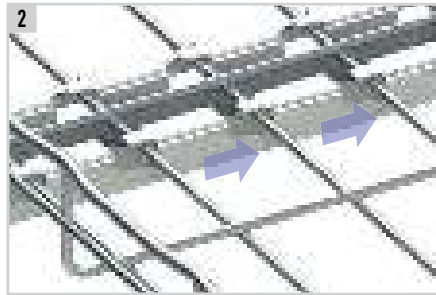

2 Slide tray under tabs

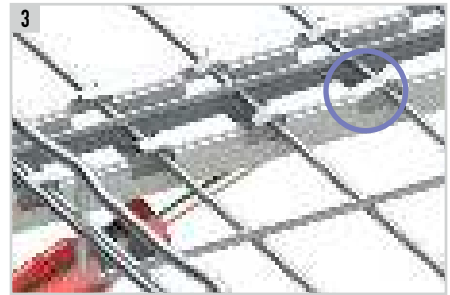

3 From the underside, depress several tabs using a screwdriver or pliers to secure tray

FOR ACCESSORIES

INSTRUCTIONS



1 Place accessory onto tray

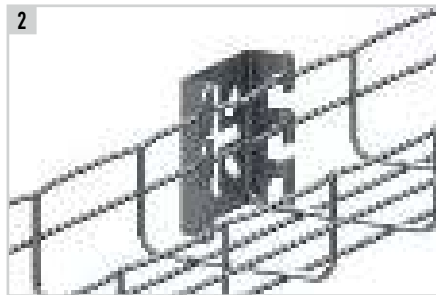

2 Slide accessory under tabs



3 Depress all tabs using a screwdriver or pliers to secure tray



T JUNCTIONS

RAD T 90 KIT

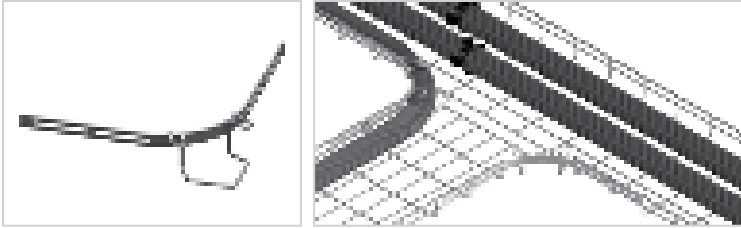

One RAD T 90 KIT will make one T Junction.
For complete kit description and depths offered
see page A.27.

4" (100 MM)

1

2

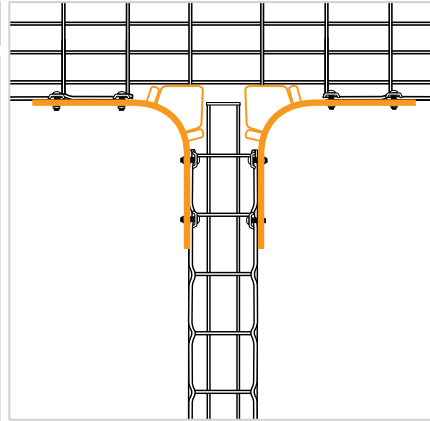

x2

- x4 EZ BN 1/4
- x4 CE 25

x1 RAD T 90

6" (150 MM)

1

2

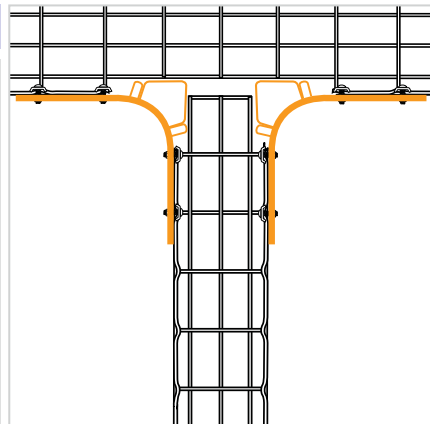

x2

- x4 EZ BN 1/4
- x4 CE 25

x1 RAD T 90

8" (200 MM)

1

2

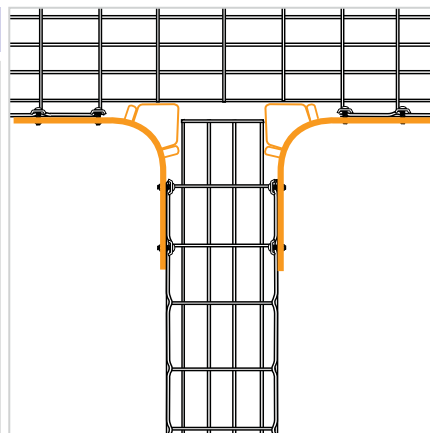

x2

- x4 EZ BN 1/4
- x4 CE 25

x1 RAD T 90

12" (300 mm)

1

2

x2

- x4
- x4

x1

18-20" (450-500 mm)

1

2

x2

- x4
- x4

x1

24" (600 mm)

1

2

x2

- x4
- x4

x1



T JUNCTIONS

EZ T 90 KIT

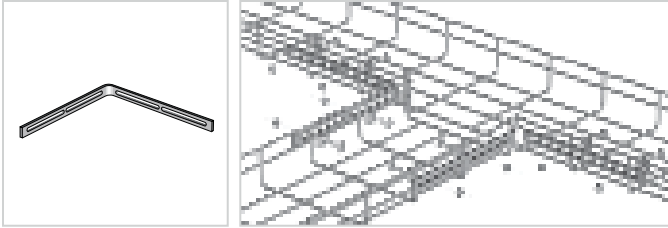

One EZ T 90 KIT will make one T Junction. For complete kit description see page A.26.

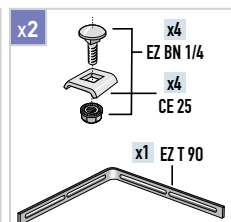
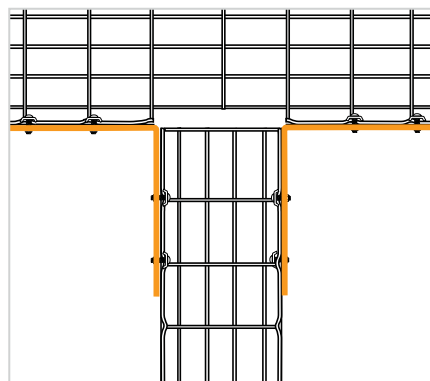
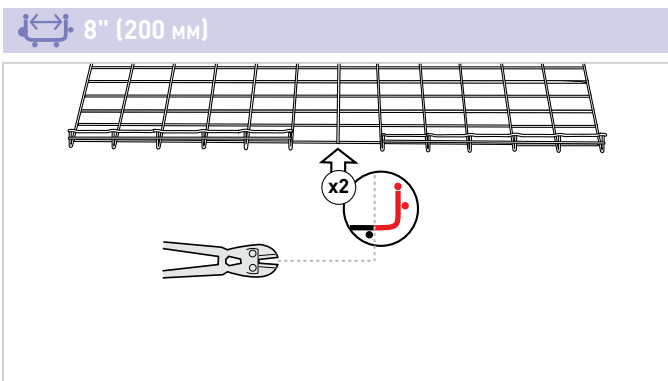
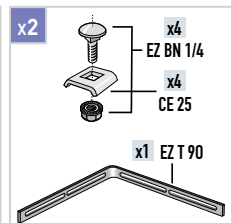
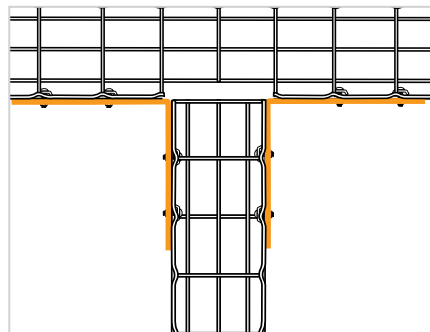
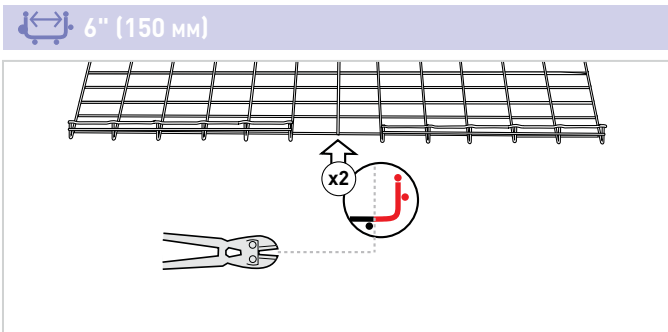
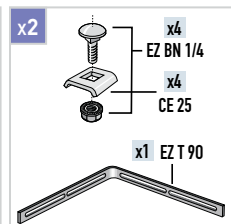
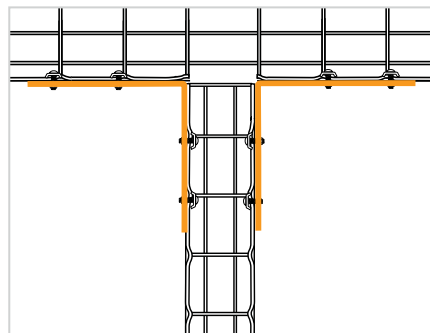
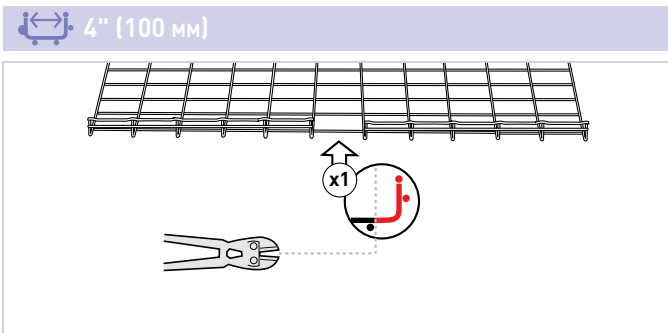
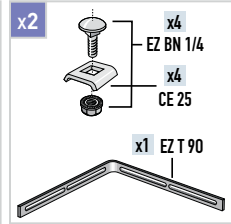
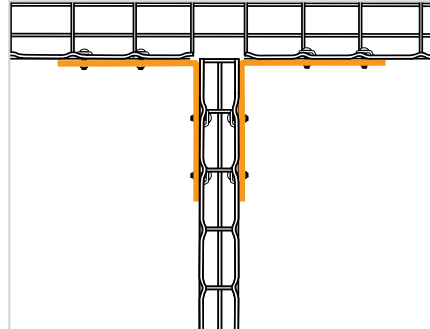
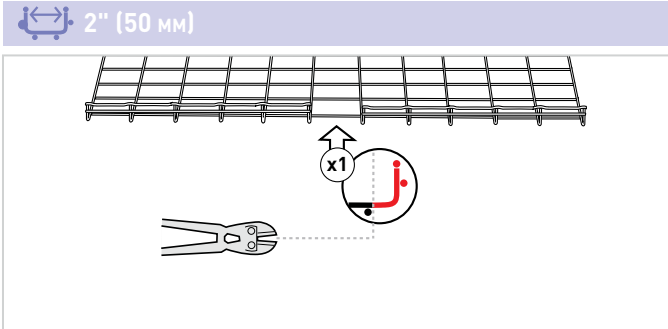

12" (300 MM)

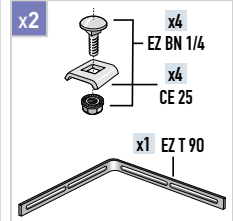
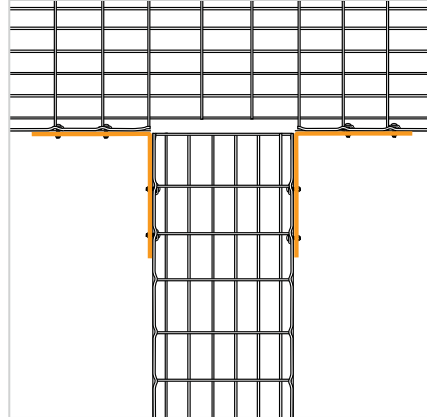
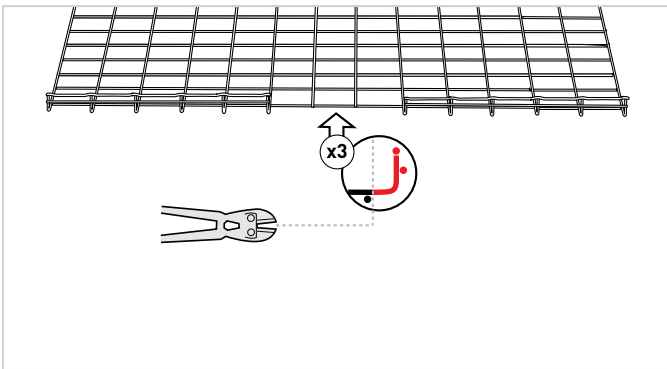

18-20" (450-500 MM)

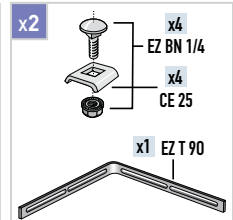
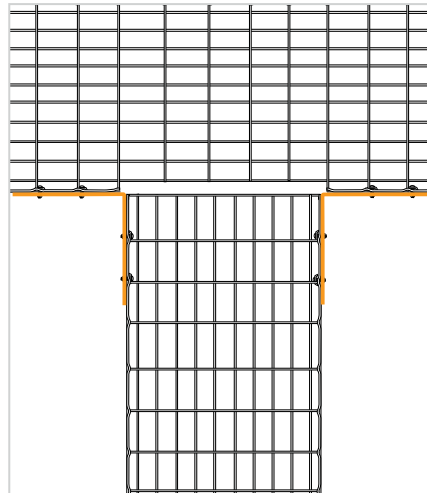
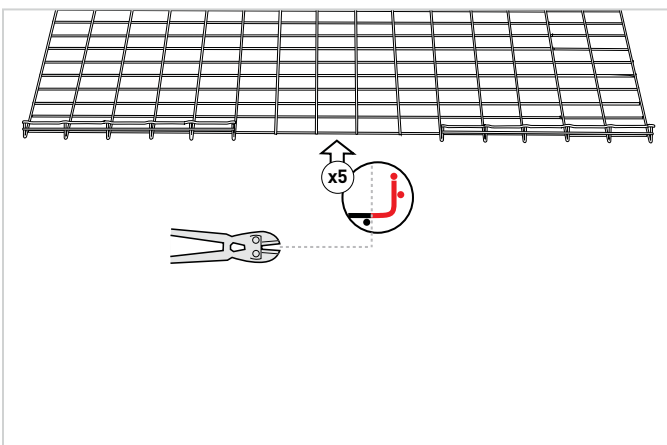

24" (600 MM)

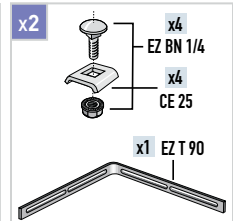
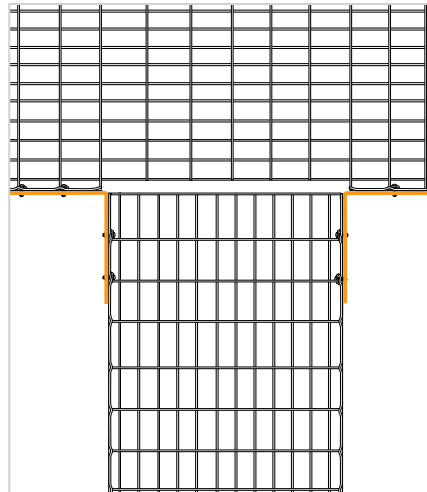
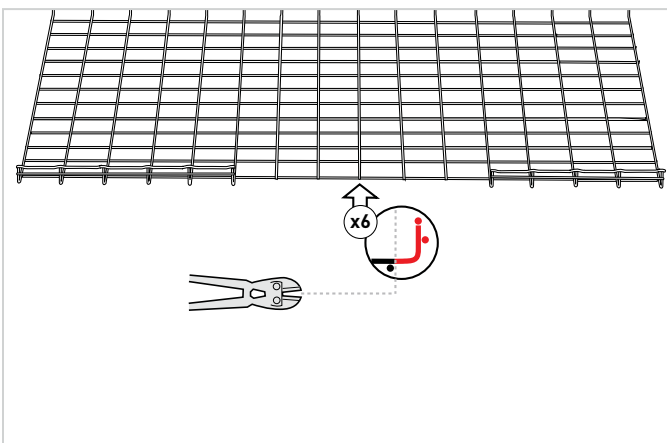

Y JUNCTIONS

4" (100 mm)

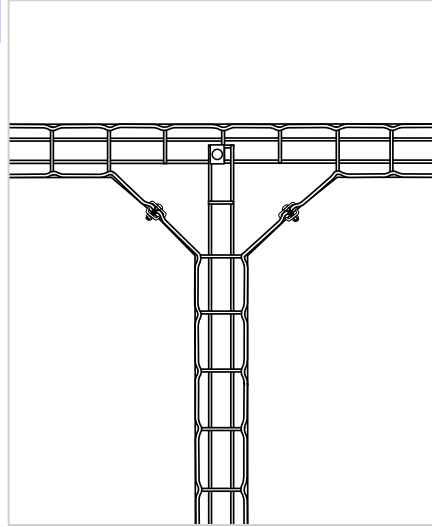
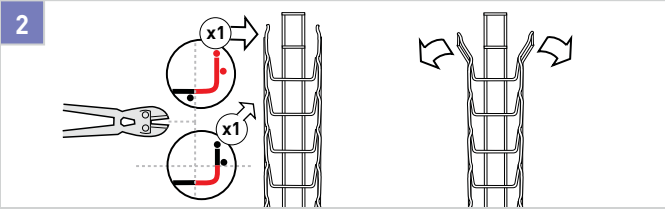
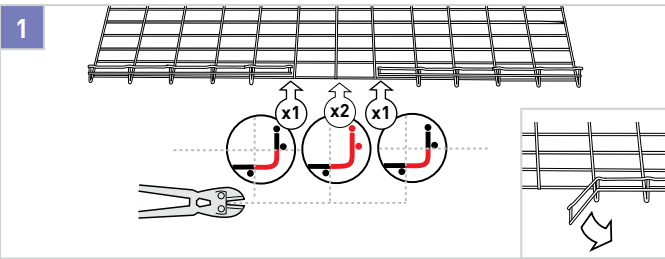

x3

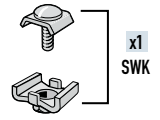

See pgs. A.80-A.81.

6" (150 mm)

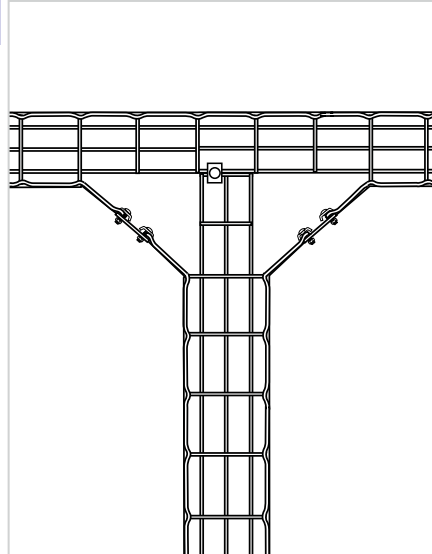
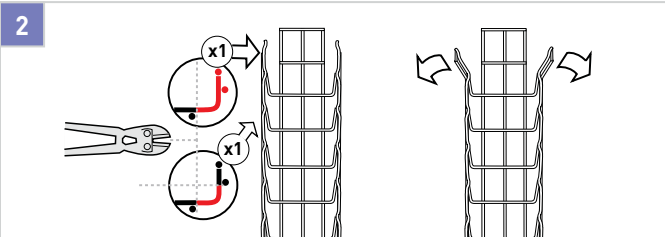
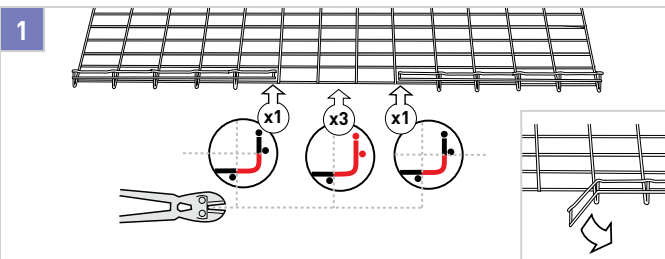

x1

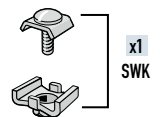

See pgs. A.80-A.81.

x2

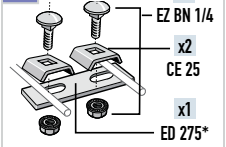

See pgs. A.80-A.81.

*Use bolt cutters to fabricate this part from ED 275.

8" (200 mm)

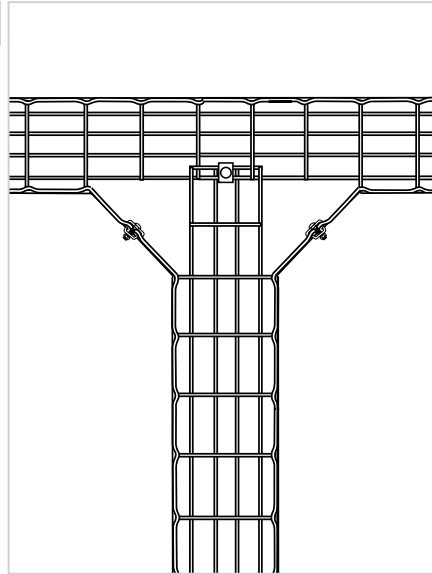
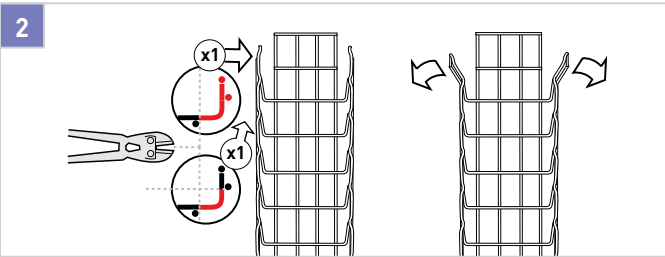
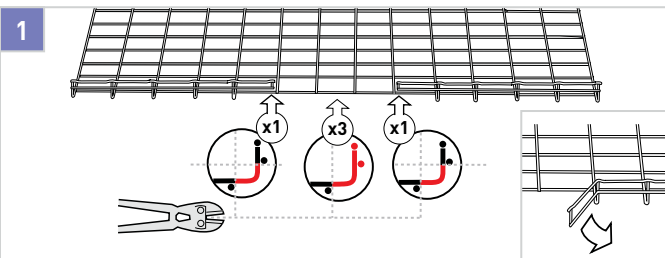

x3

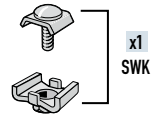

See pgs. A.80-A.81.

12" - 20" - 24" (300 - 500 - 600 mm)

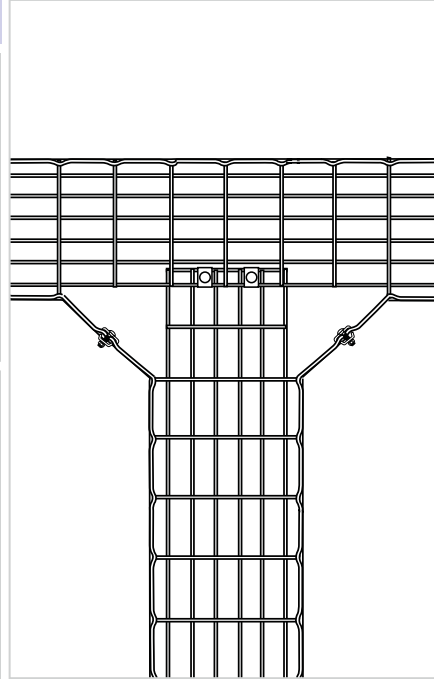
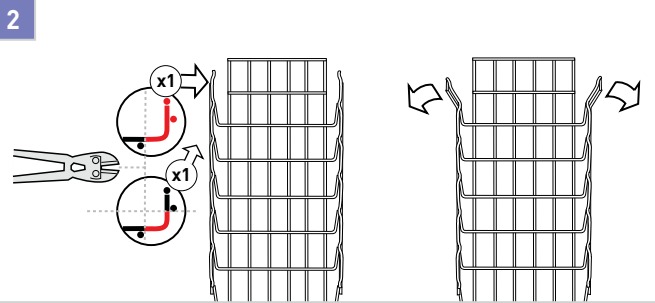
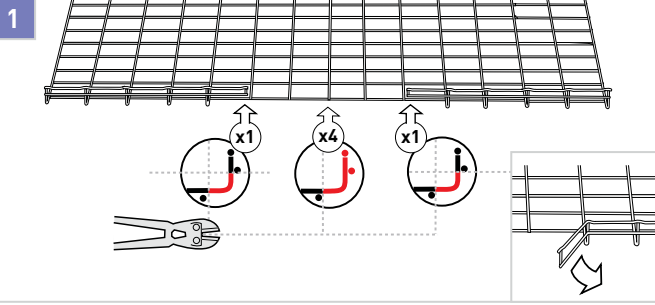

x4

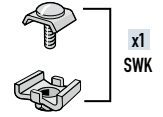

See pgs. A.80-A.81.

18" (450 mm)

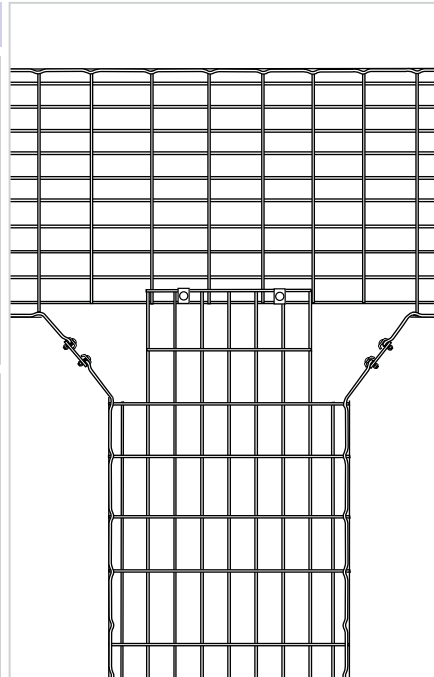
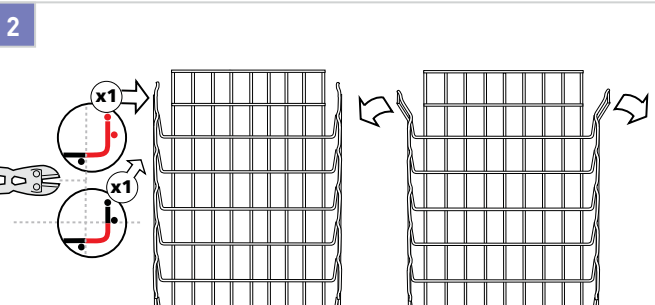
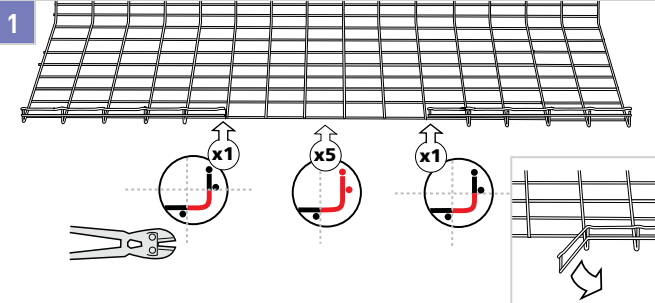

x2

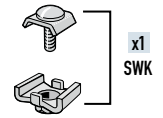

See pgs. A.80-A.81.

x2

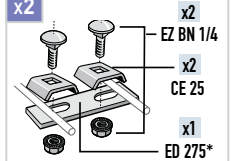

See pgs. A.80-A.81.

*Use bolt cutters to fabricate this part from ED 275.



90° BENDS
RAD T 90 KIT

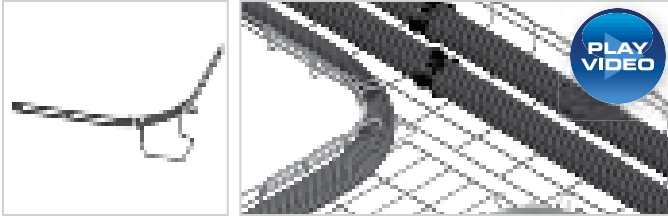

One RAD T 90 KIT will make two 90° Bends. For complete kit description and depths offered, see page A.27.

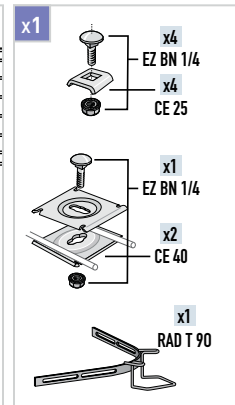
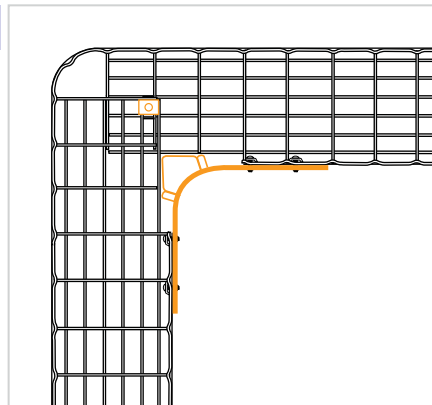
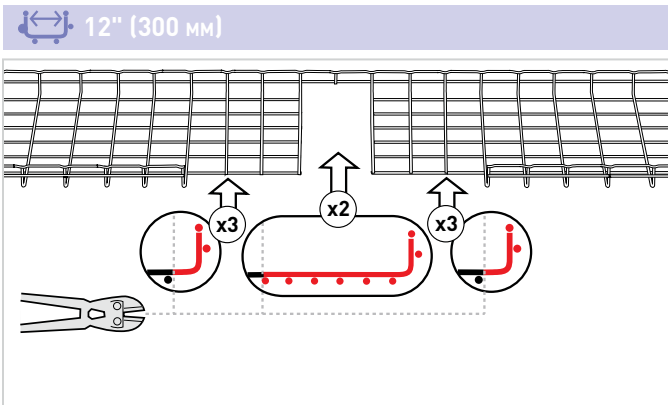
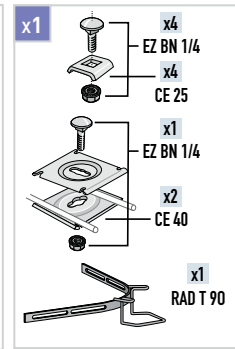
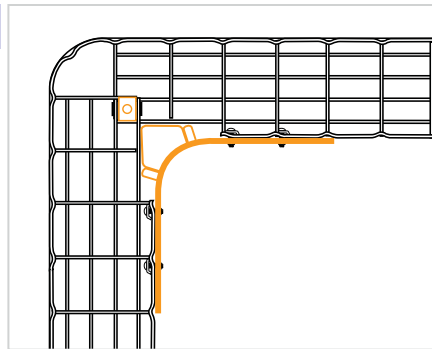
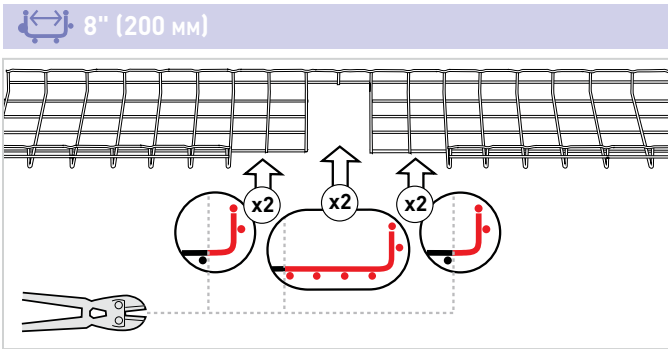
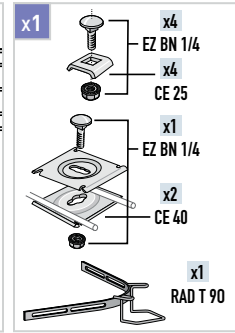
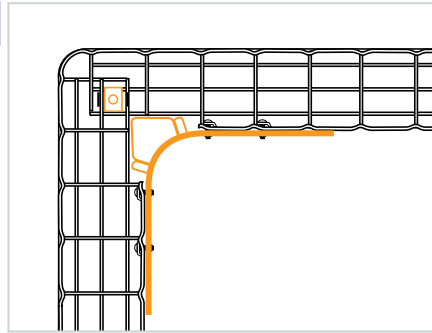
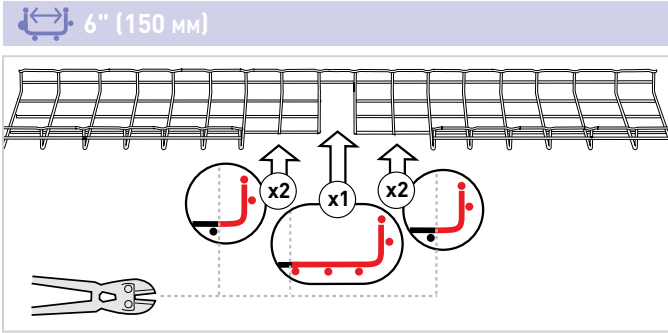
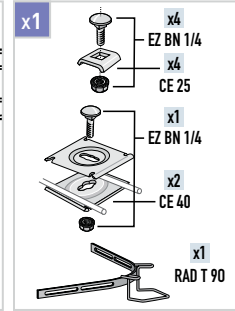
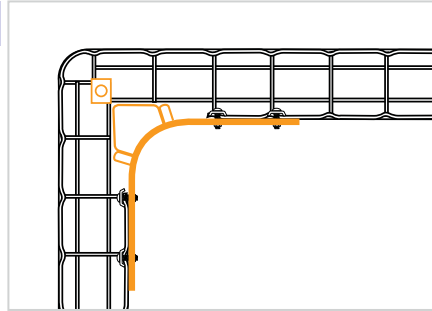
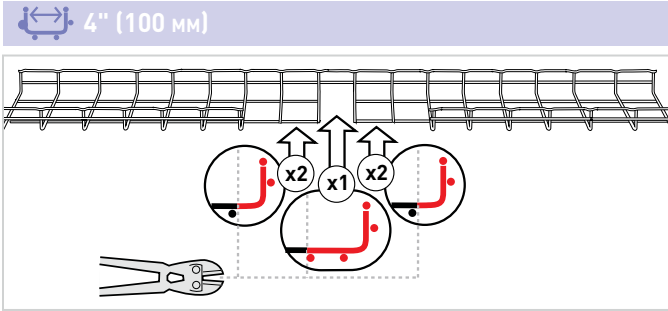

18" (450 mm)

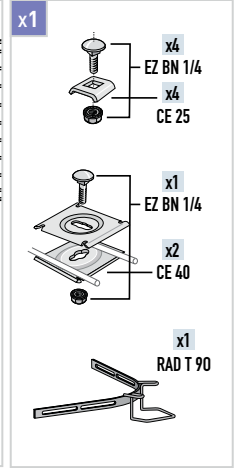
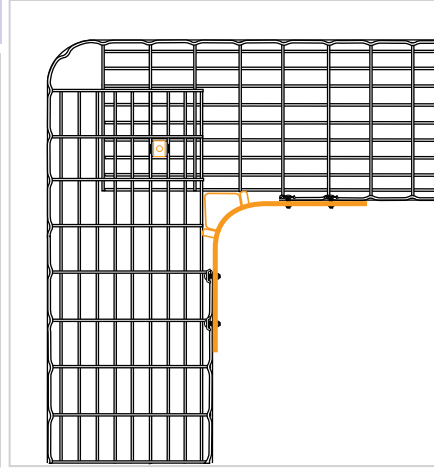
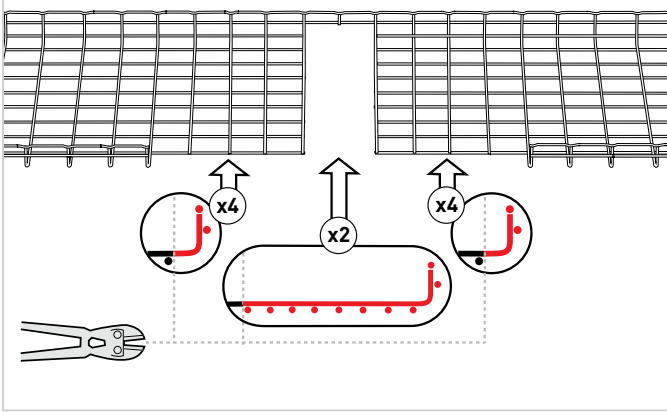

20" (500 mm)

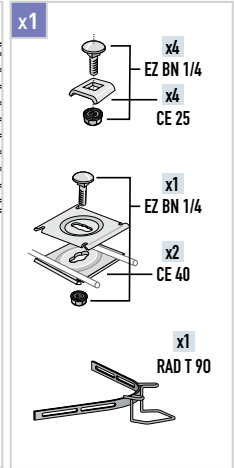
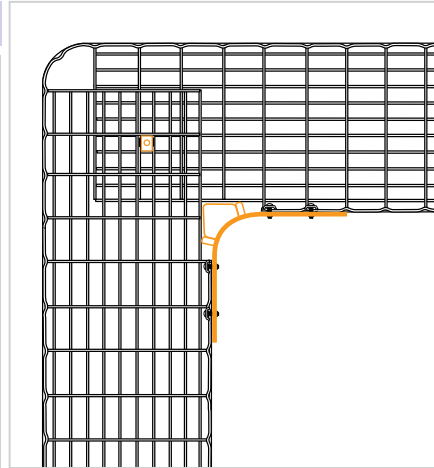
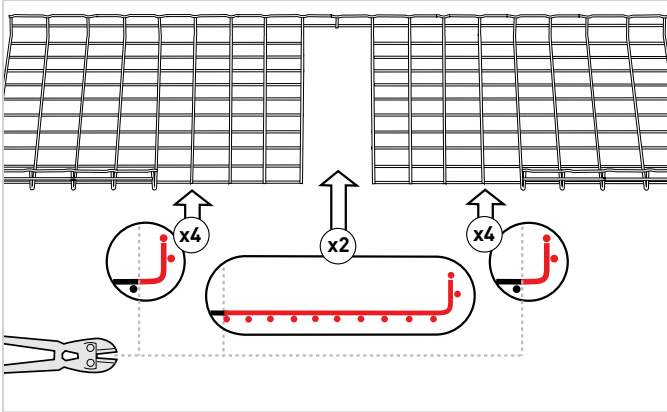

24" (600 mm)

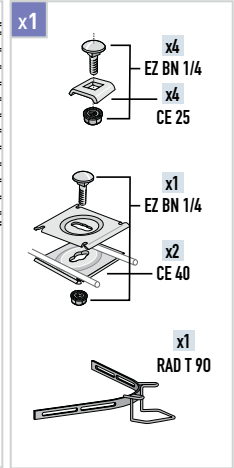
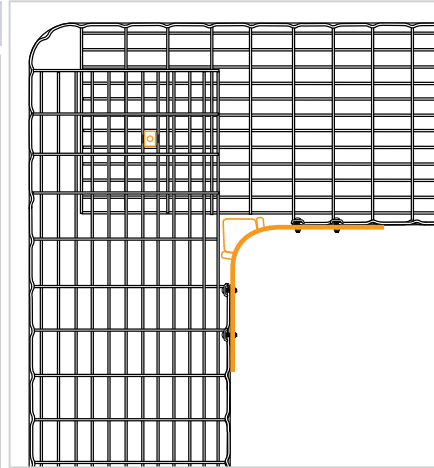
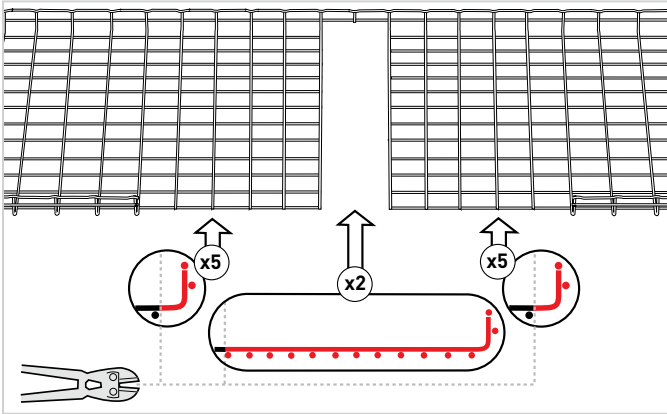

90° BENDS EZ T 90 KIT

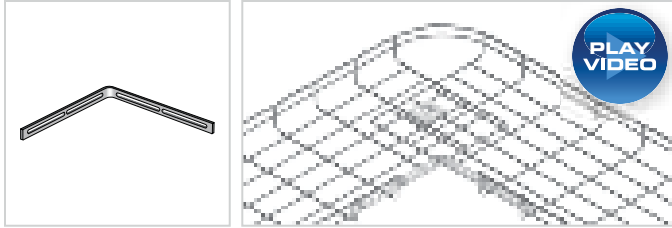

One EZ T 90 KIT will make two 90° Bends.
For complete kit description, **see page 26.**

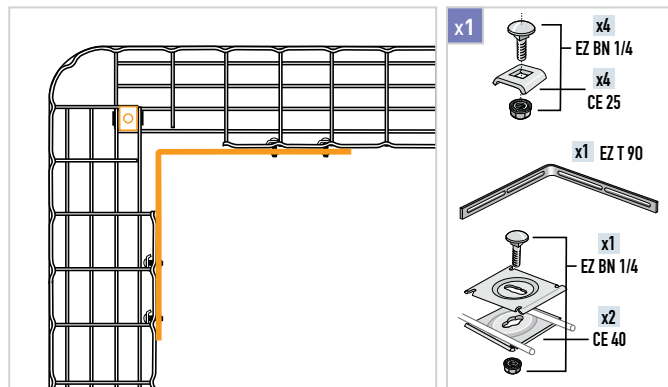
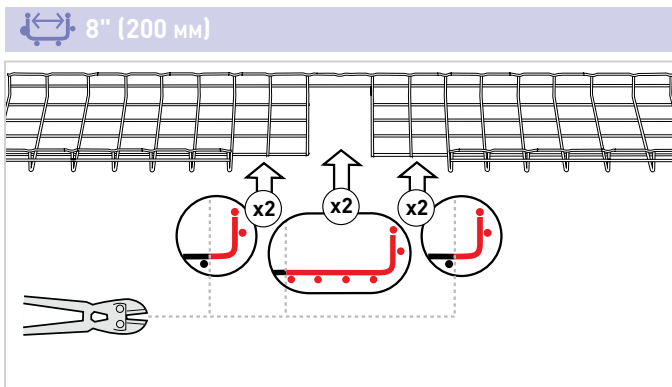
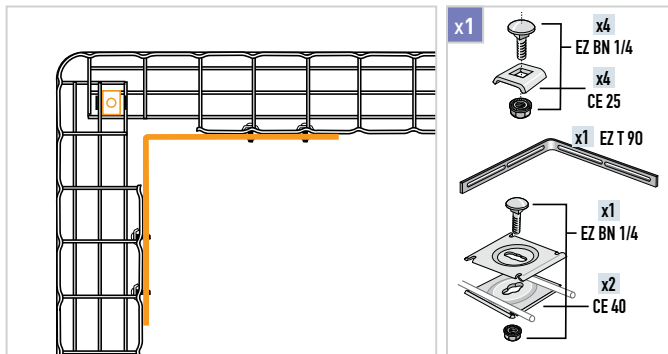
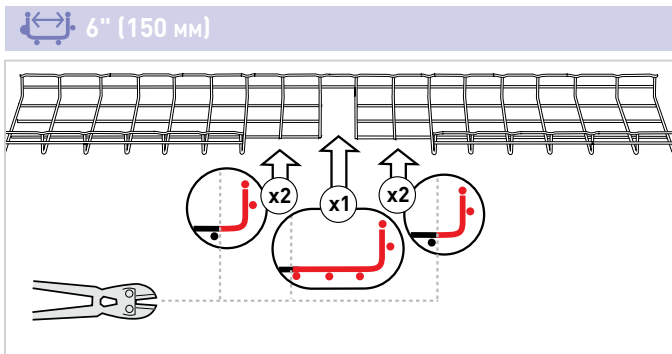
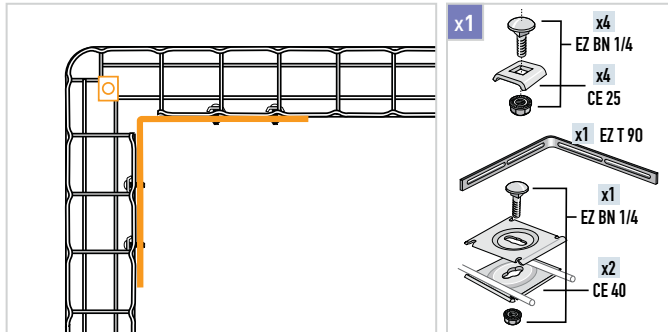
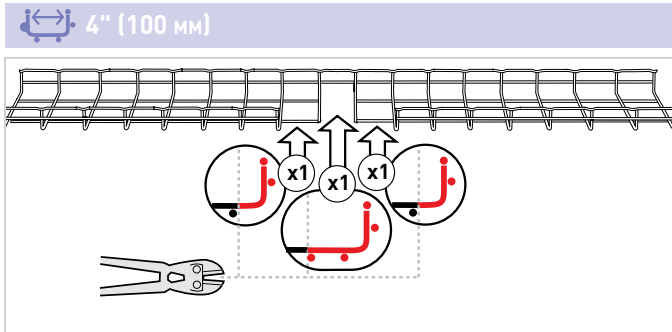
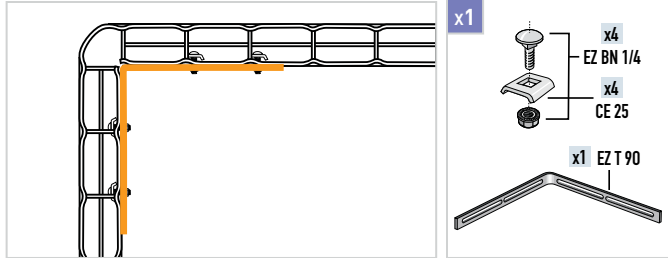
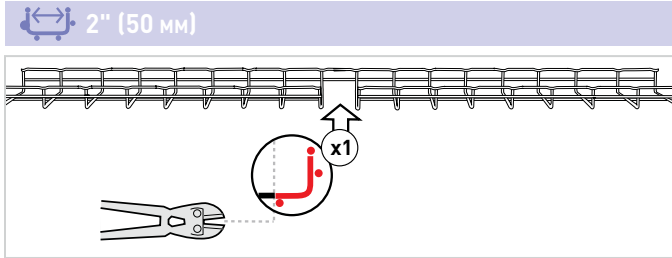

12" (300 mm)

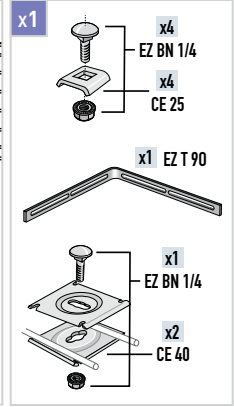
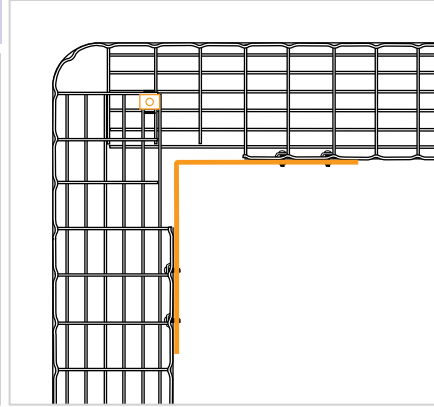
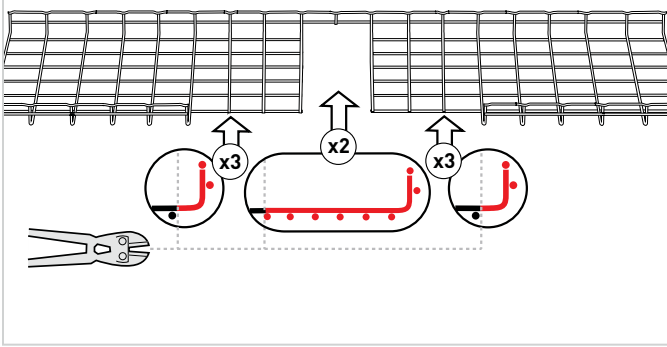

18" (450 mm)

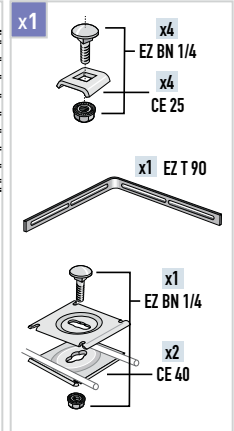
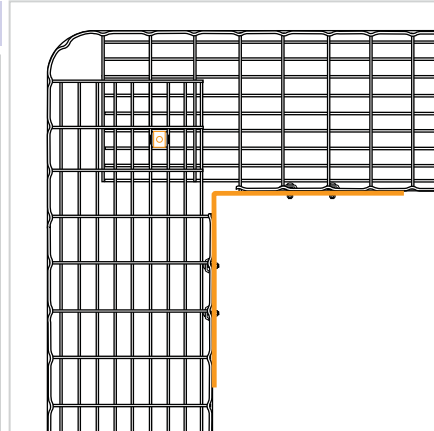
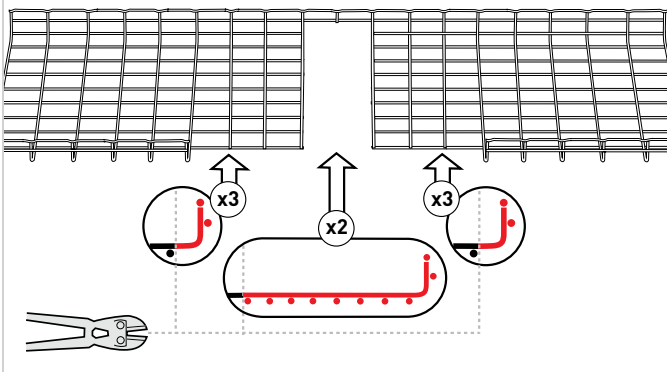

20" (500 mm)

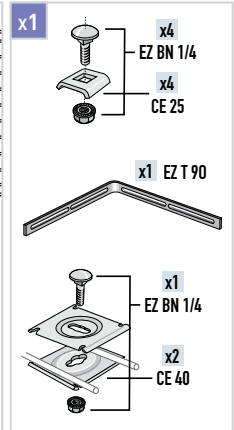
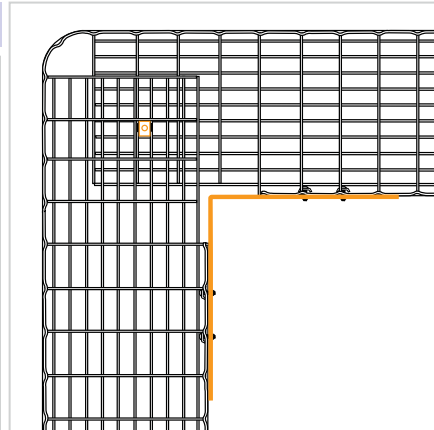
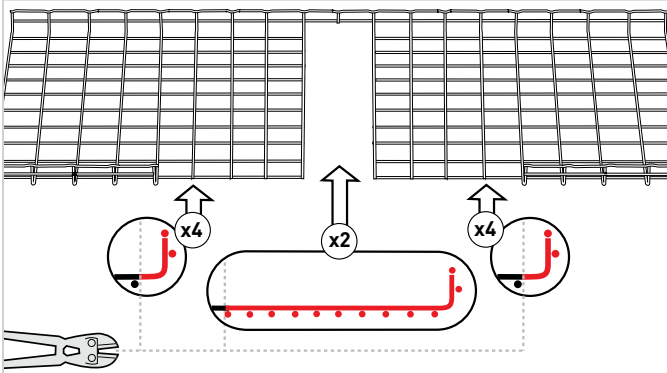

24" (600 mm)

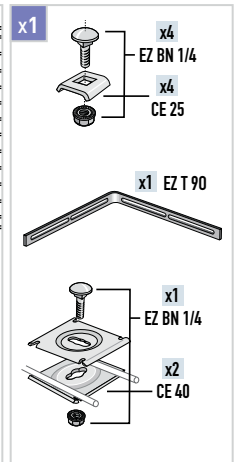
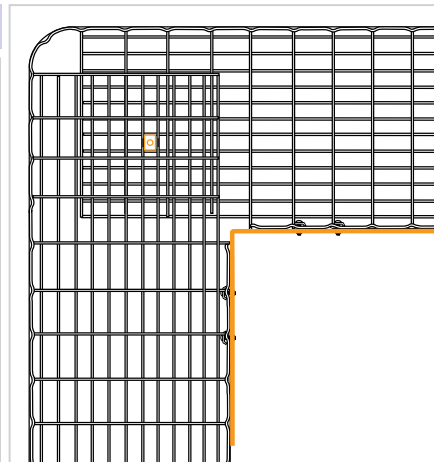
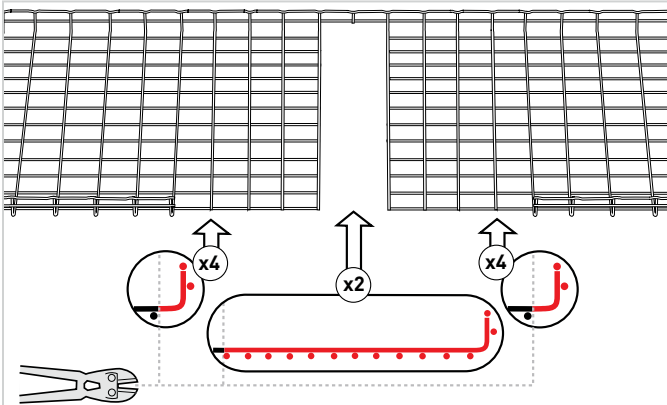

90° JUNCTIONS EZ T 90 KIT

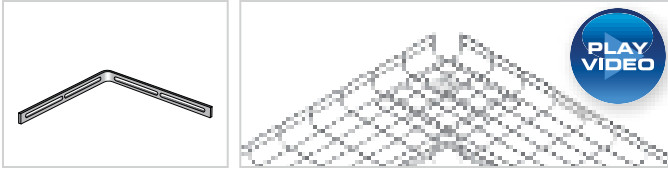

PLAY VIDEO

One EZ T 90 KIT will make two 90° Junctions.
For complete kit description, see page 26.

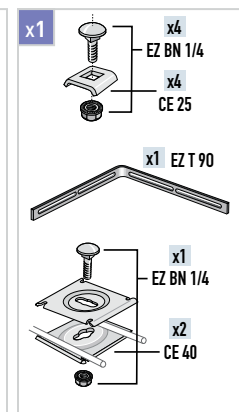
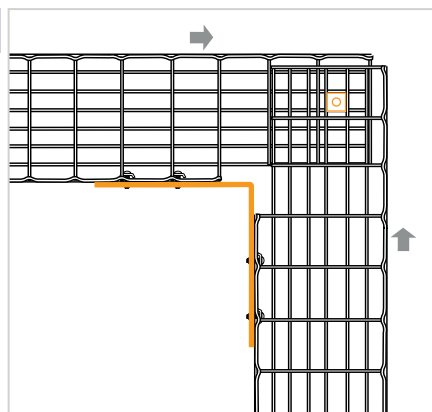
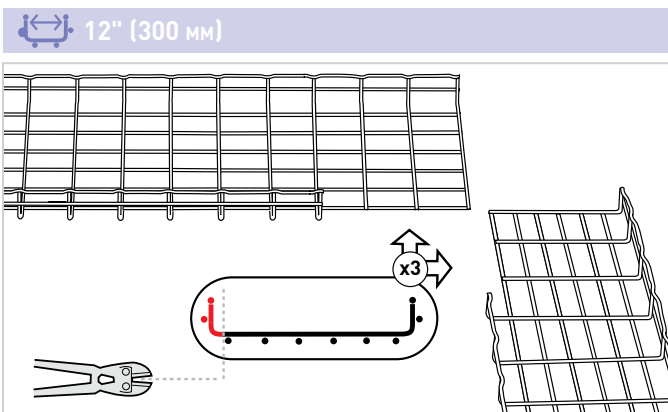
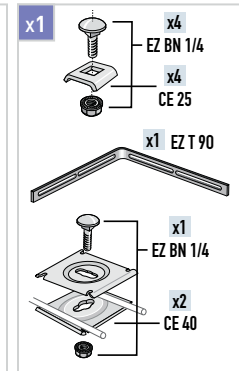
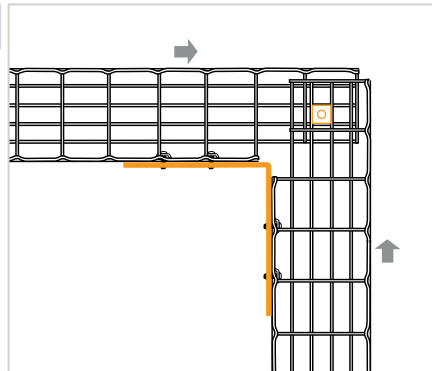
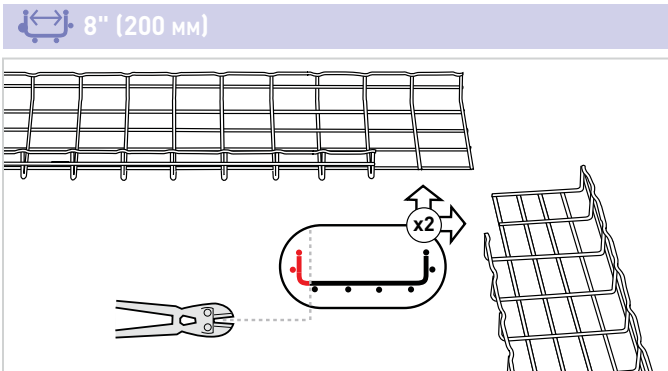
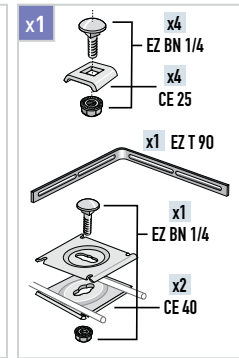
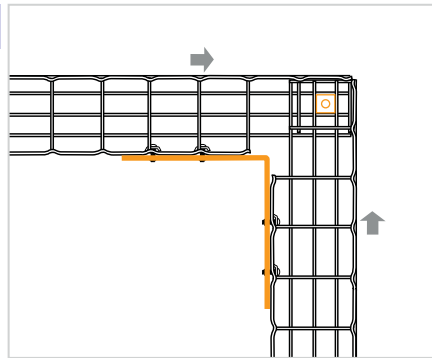
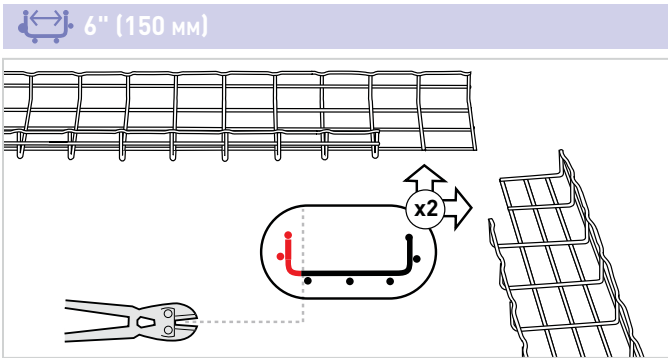
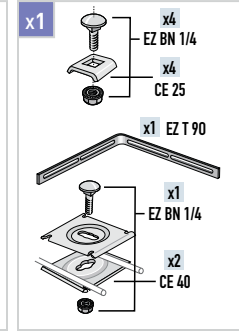
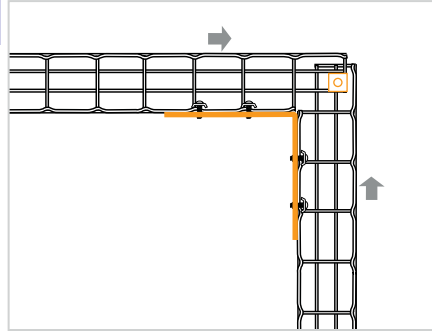
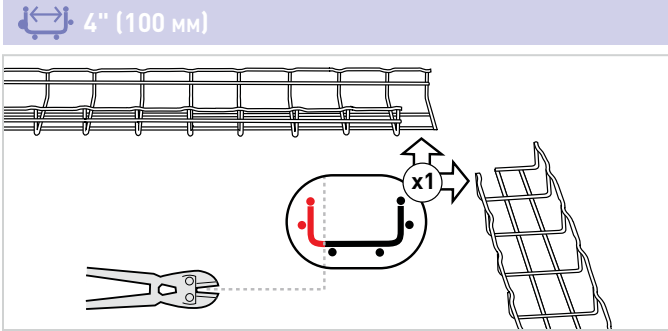

18" (450 mm)

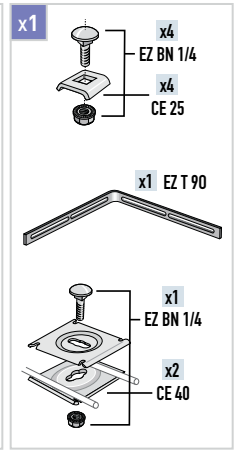
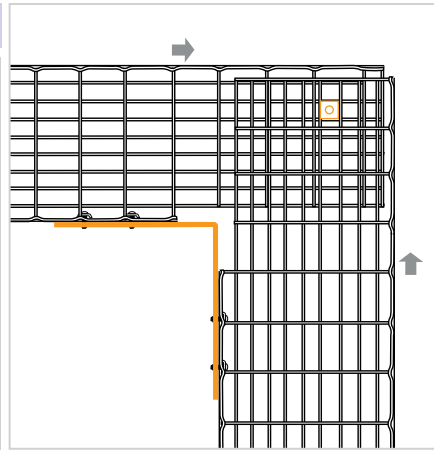
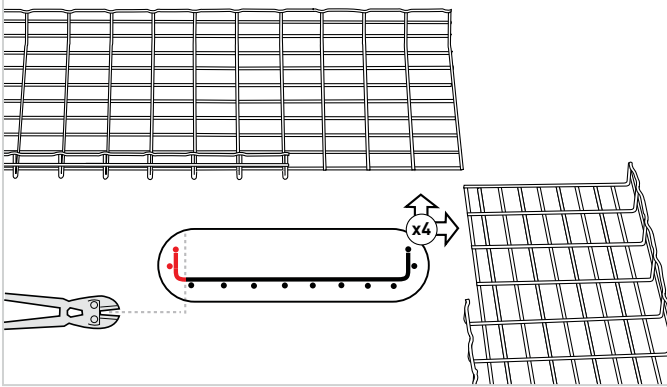

20" (500 mm)

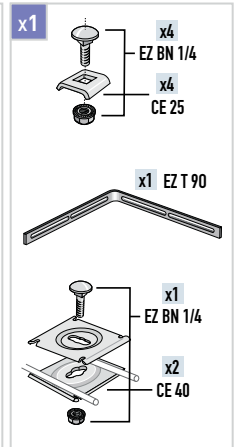
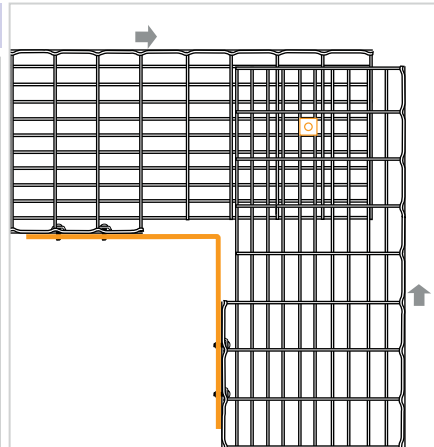
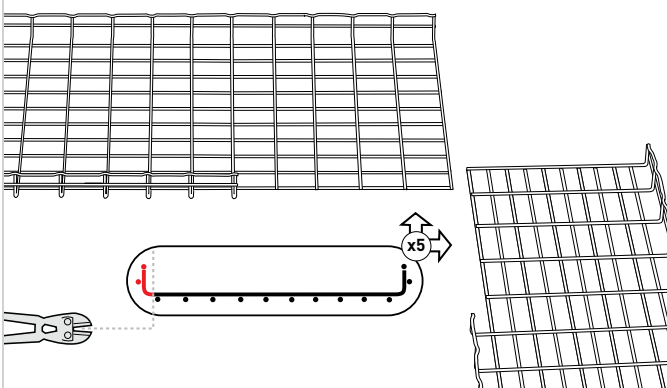

24" (600 mm)

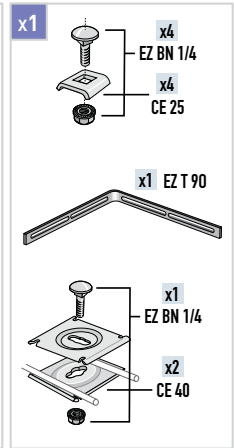
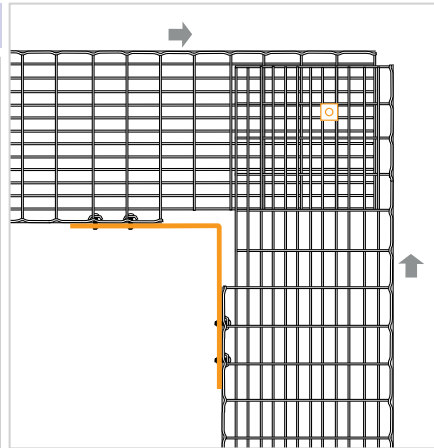
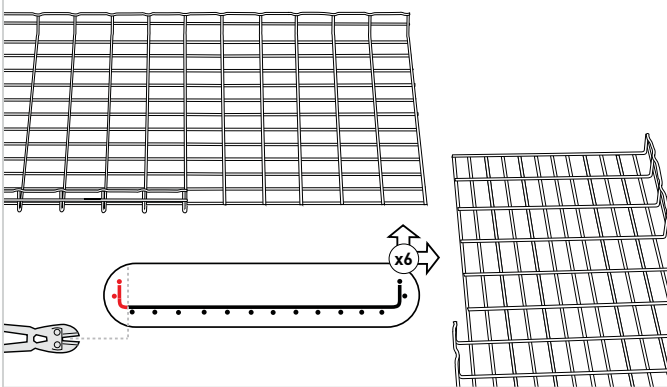

OTHER THAN 90° JUNCTIONS

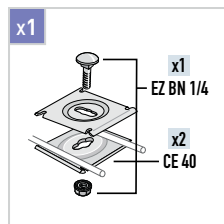
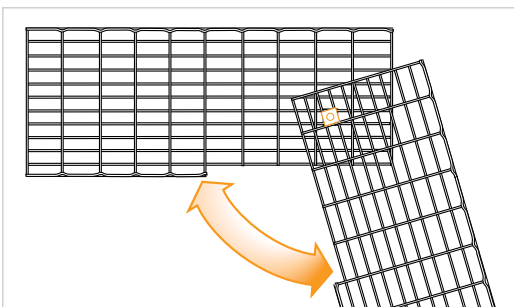

SWEEPS

SWK & EZ BN 1/4 / CE 25 / ED 275

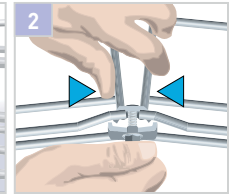
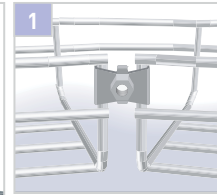
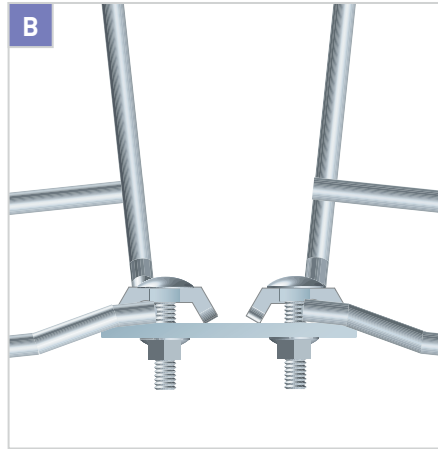
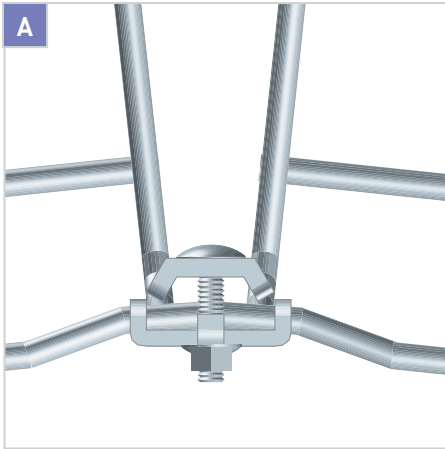

- Sweeps can be formed easily on site by cutting some of the side and bottom wires. Use the SWK method to secure desired curve.
- Always place bolt heads to inside of tray to prevent frayed wires.
- Use bolt cutters to fabricate this part from ED275.

2" (50 mm)

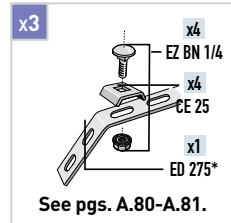
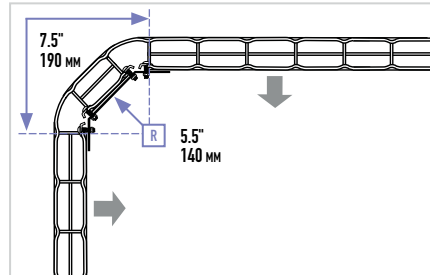
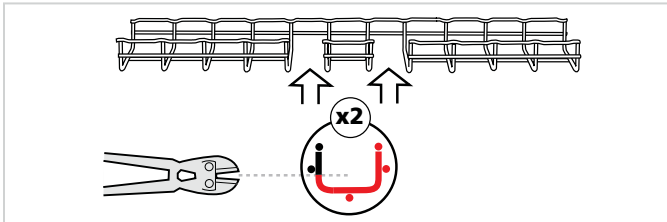

4" (100 mm)

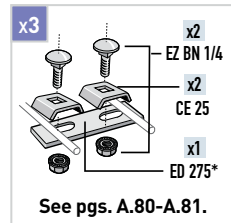
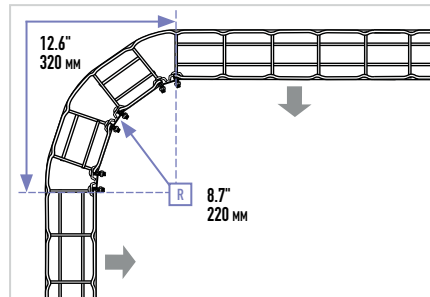
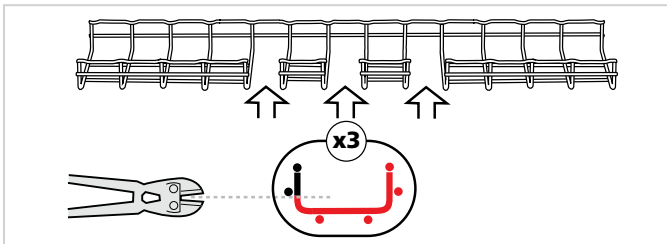

6" (150 mm)

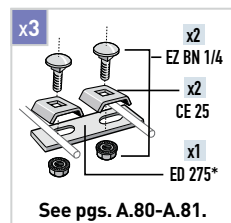
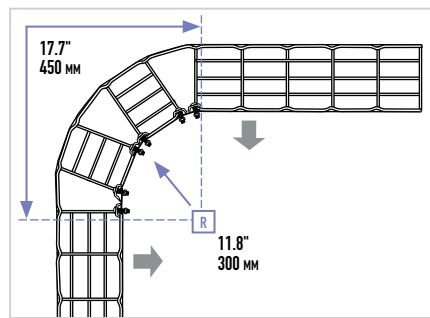
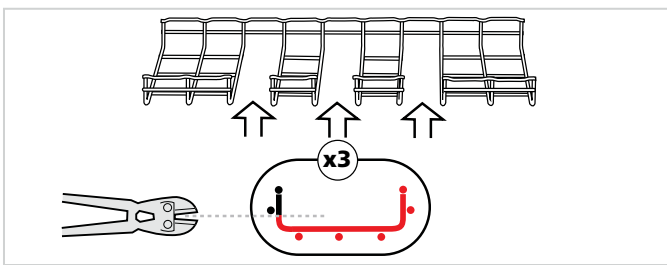

8" (200 mm)

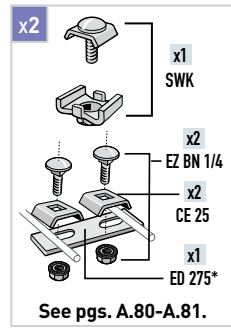
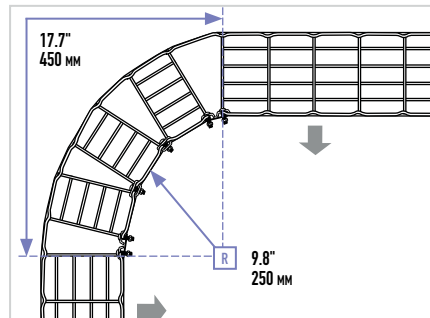
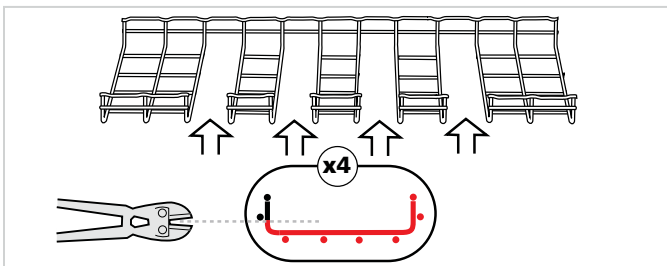

12" (300 mm)

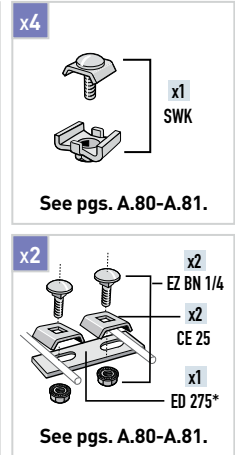
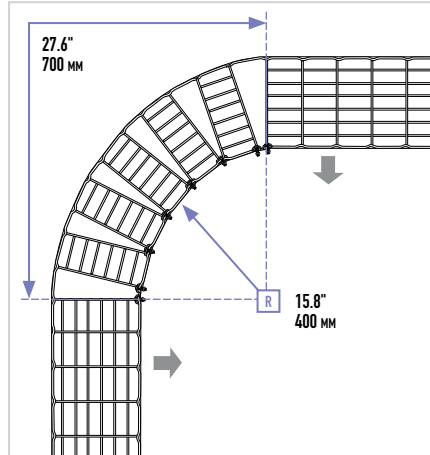
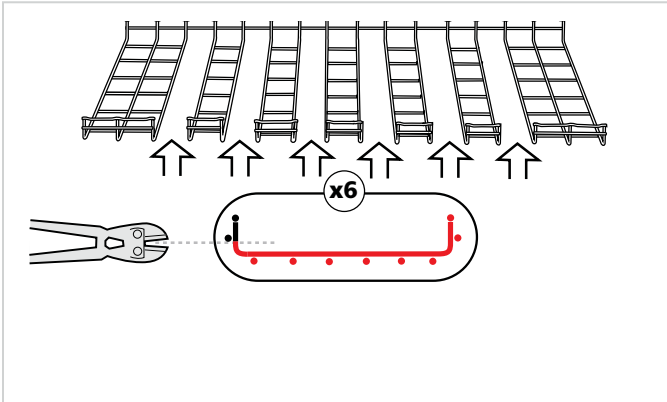

18" (450 mm)

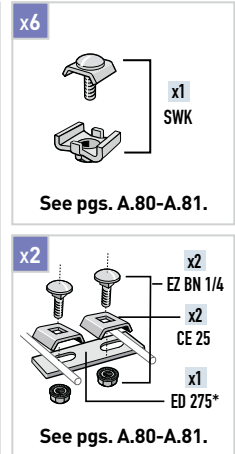
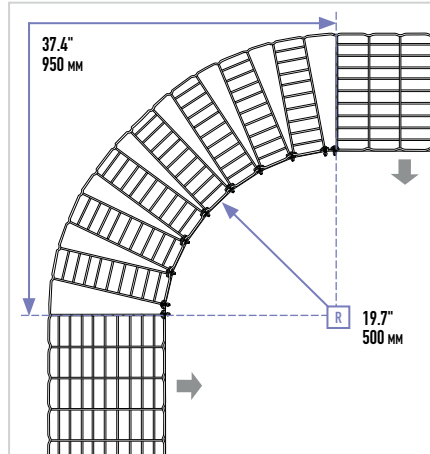
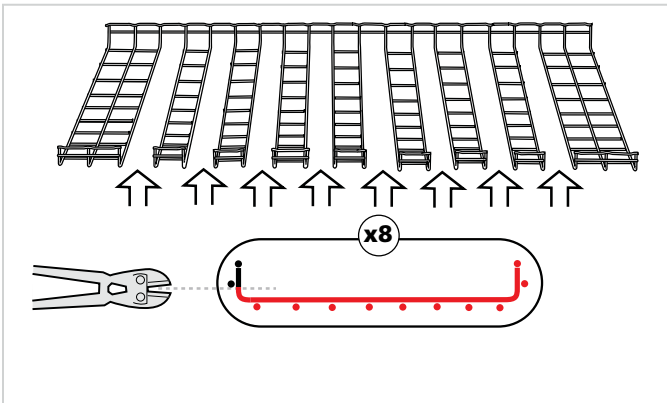

20" (500 mm)

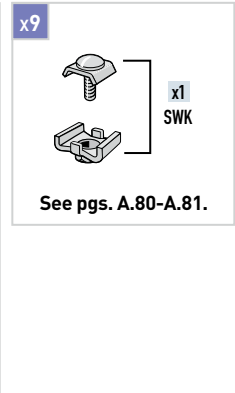
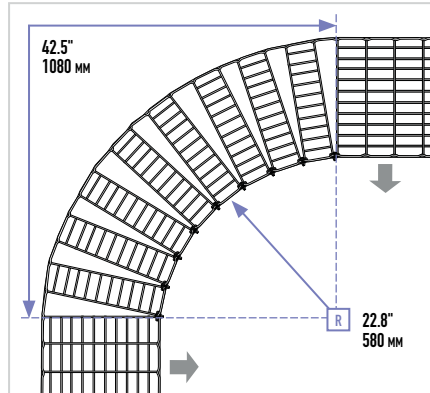
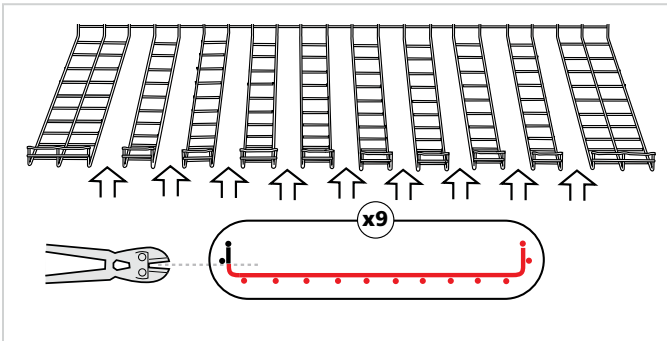

24" (600 mm)

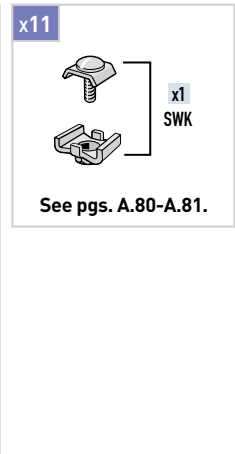
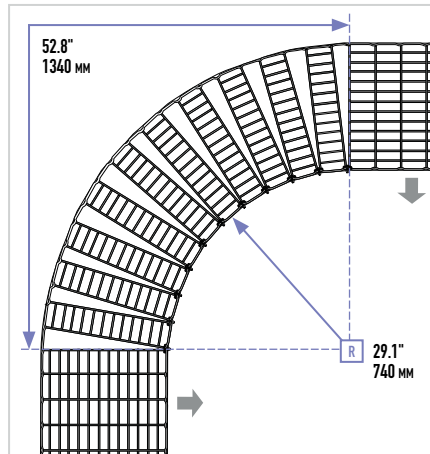
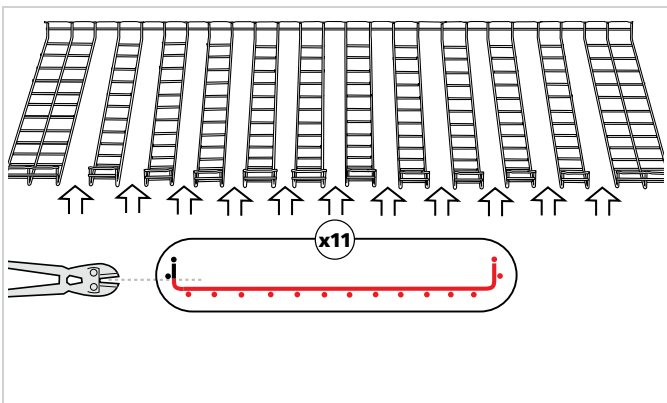

SWEEPS
FASLOCK



Sweeps can be formed easily on site by cutting some of the side and bottom wires. Use the FASLOCK method to secure desired curve.

See page 81.

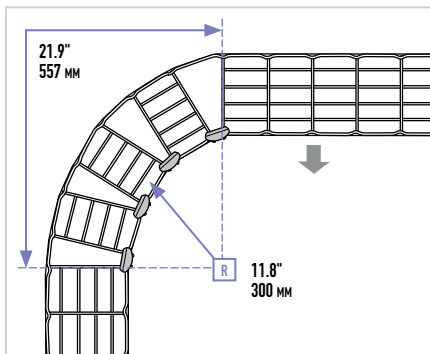
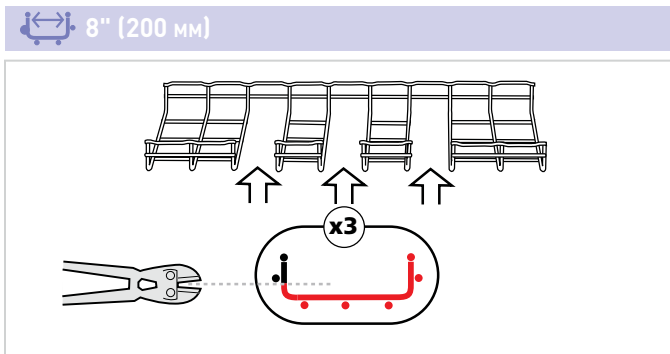
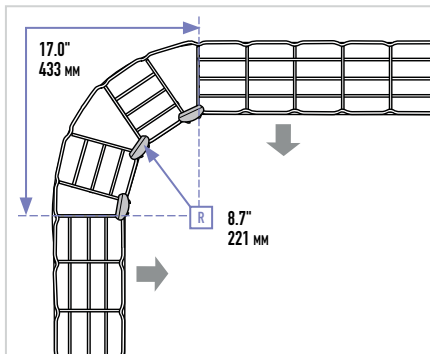
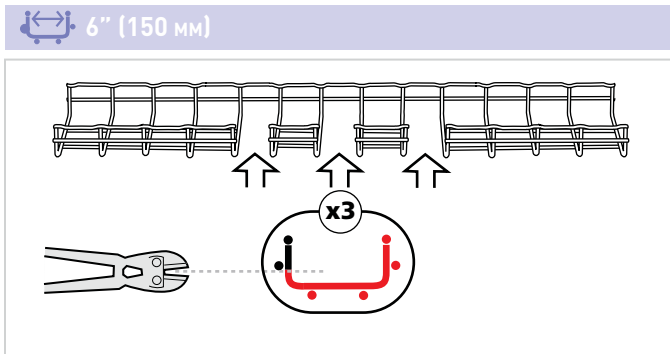
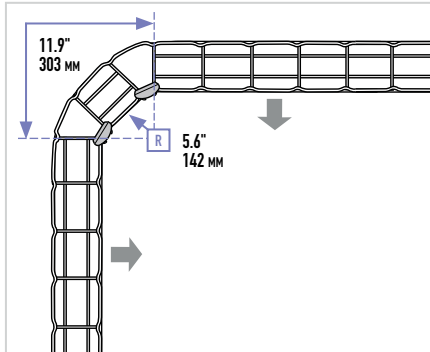
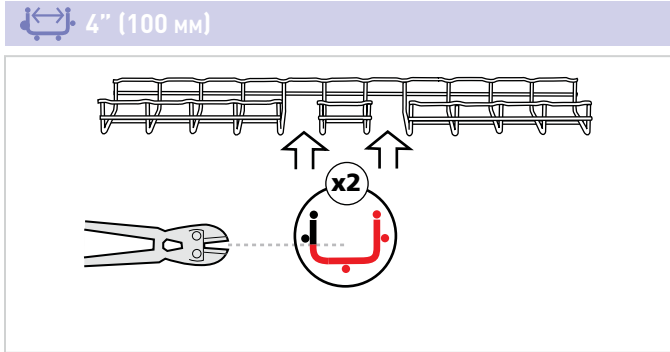
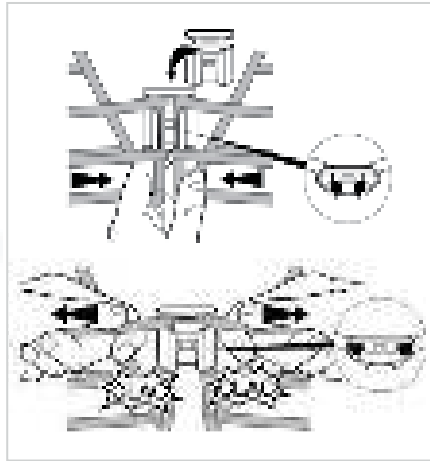

12" (300 mm)

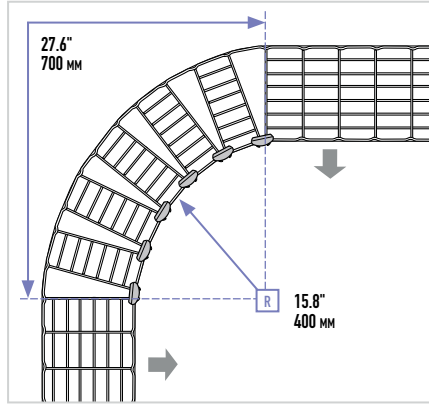
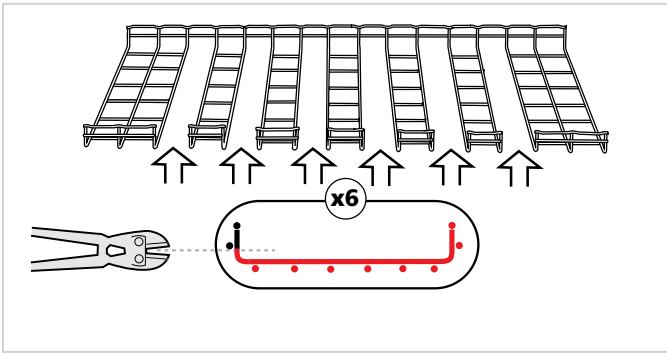

18" (450 mm)

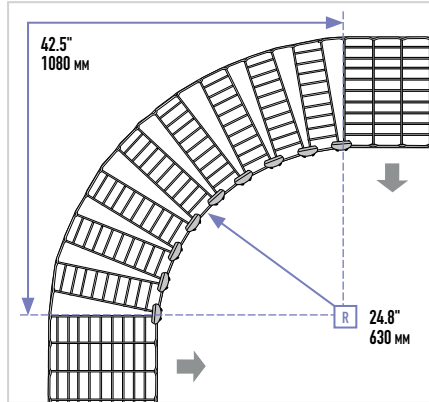
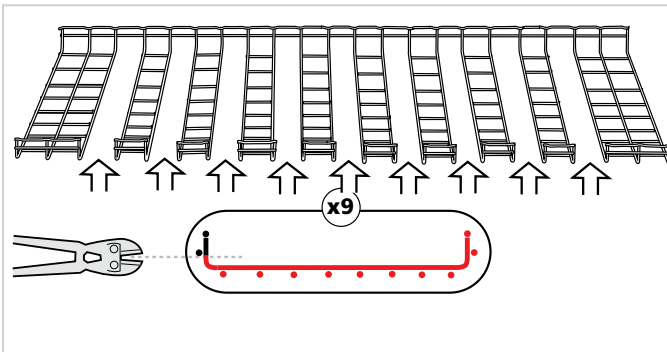

20" (500 mm)

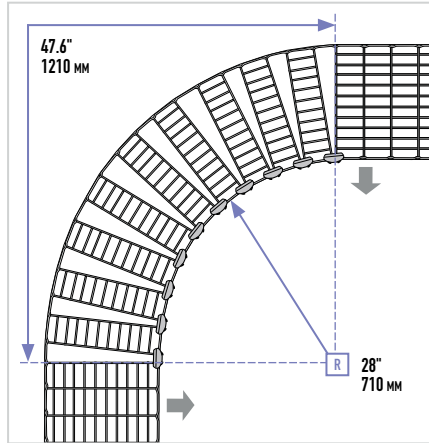
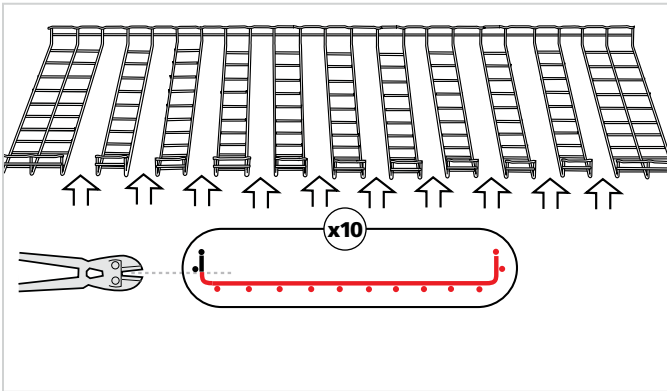

24" (600 mm)

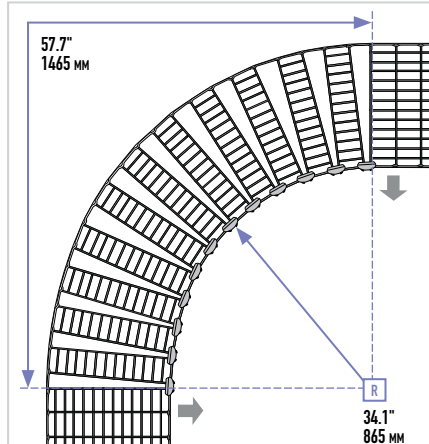
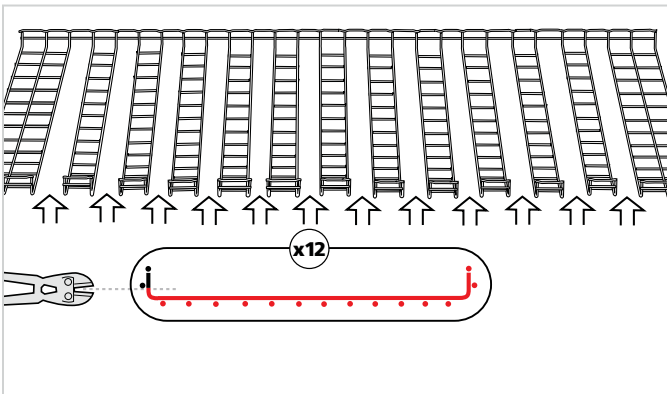

*Use FASLOCK S for 100mm - 200mm widths. Use FASLOCK XL for 300mm - 600mm widths.



REDUCTIONS

4" (100 mm)

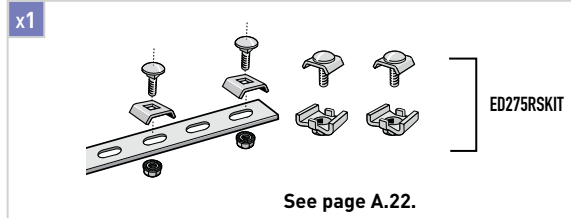
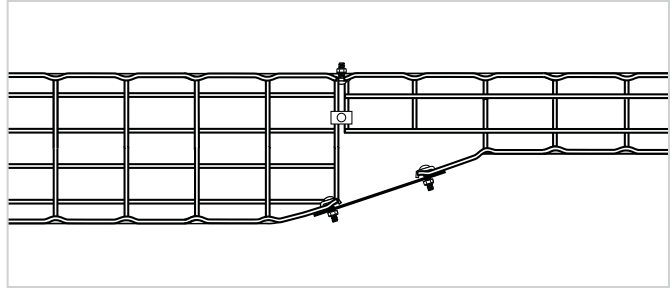
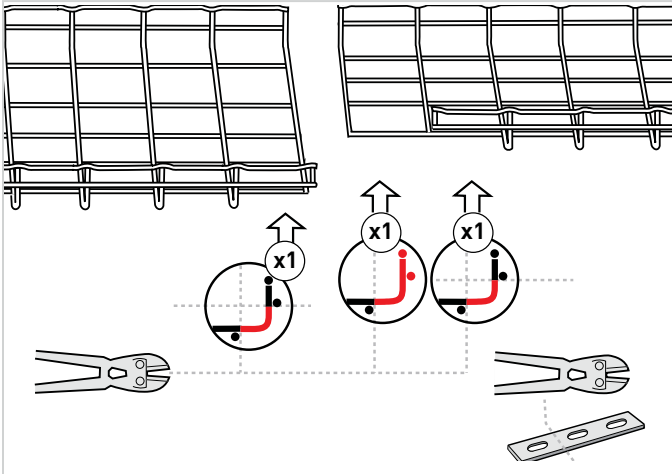

8" (200 mm)

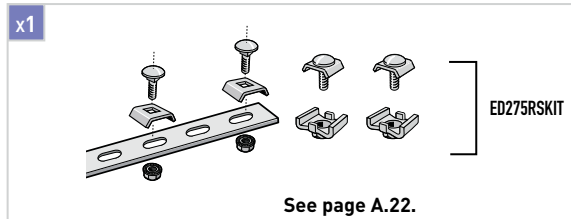
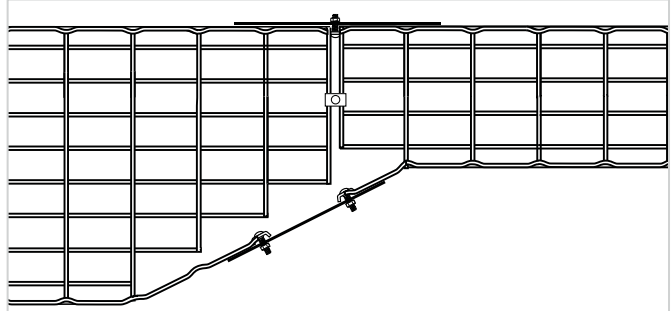
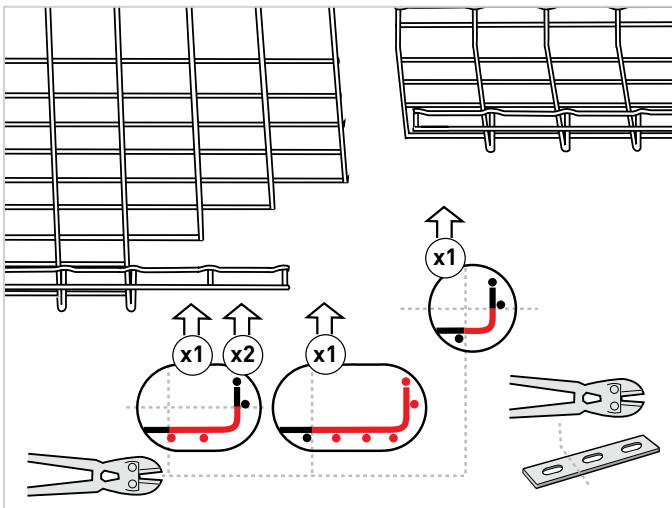

12" (300 mm)

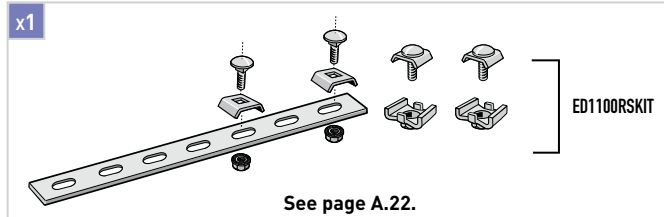
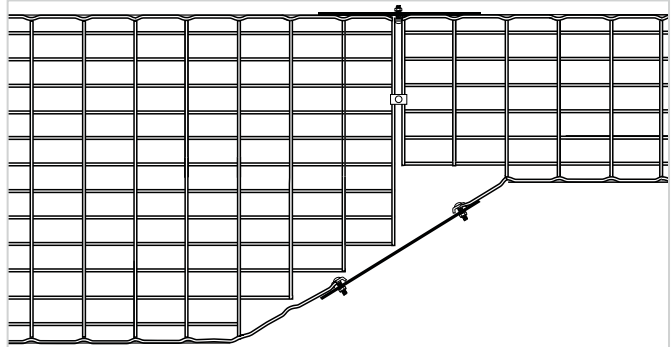
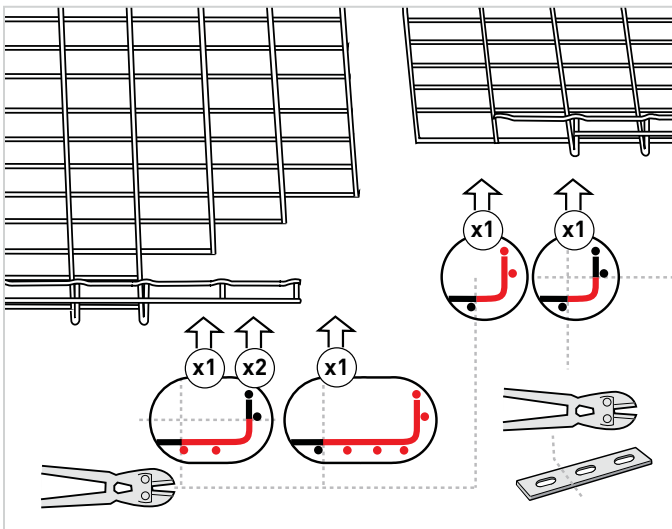

CHANGING LEVELS

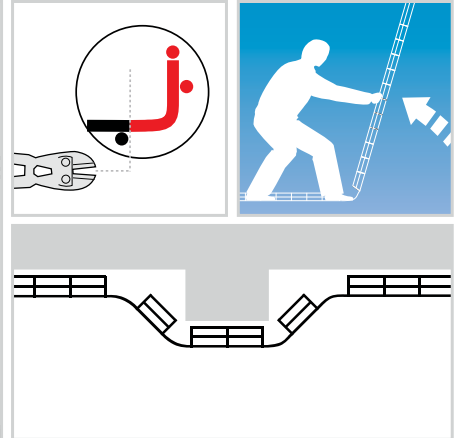
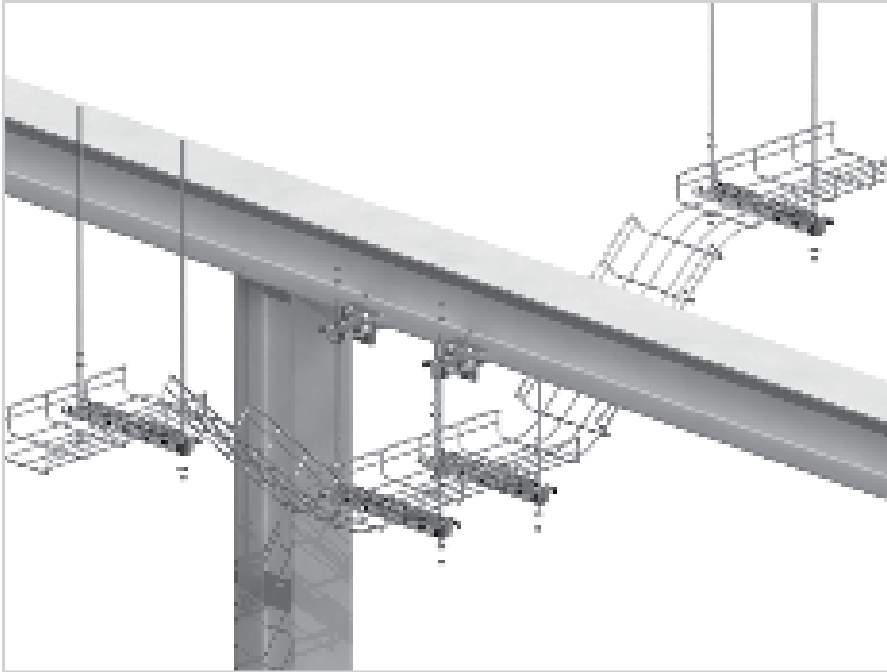

To avoid obstructions or change levels, cut the side wires as shown and bend Cablofil tray to the angles needed.

CUTTING AND BENDING

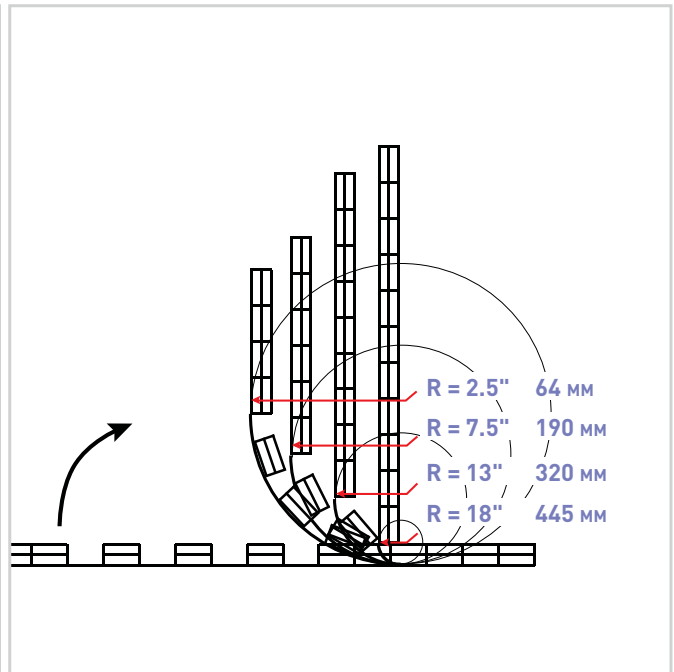
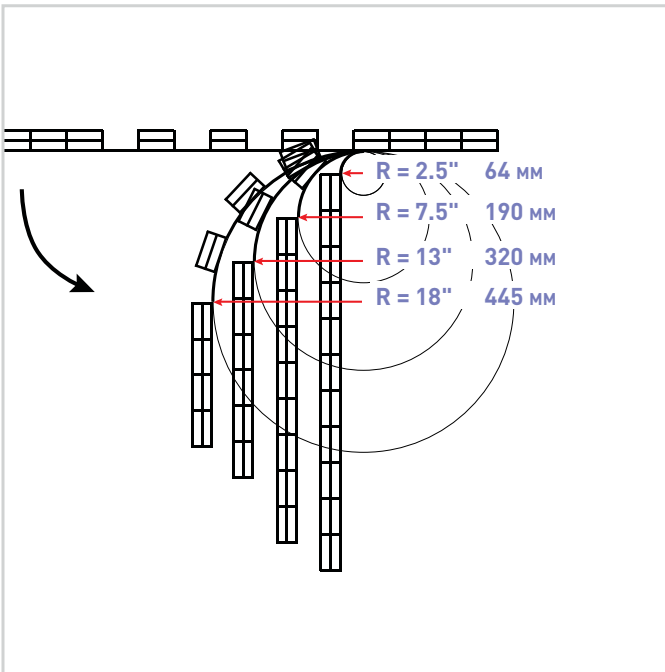



PW

TABLE OF CONTENTS

INTRODUCTION

PAGES B.1-B.7

LADDER TRAY, TROUGH & SOLID BOTTOM

PAGES B.8-B.79

- ITRAY PAGES B.10-B.25
- METALLIC PAGES B.26-B.69
- FIBERGLASS PAGES B.70-B.79

CHANNEL SYSTEMS

PAGES B.80-B.89

CABLE RUNWAY

PAGES B.90-B.95

PW CABLE TRAY

Built to Handle the Load

QUALITY AND INNOVATION FOR OVER 60 YEARS.

Cable tray, introduced in the mid 1940's, has proved to be a very efficient cable management solution. It provides system flexibility and expandability with substantial savings in installation labor and material costs. For more than six decades the PW brand has played a leadership role in the cable tray industry, providing advanced cable management solutions.



Our latest innovation is Itray. It's aluminum cable tray that been redesigned with stronger side rails and faster splicing options to streamline the engineering, purchasing and installation of cable tray. And continue to look to PW cable management to support extremely heavy cabling and bridge roadways, our exclusive long span/heavy duty cable tray is designed with up to 10" I-beam side rails that can span up to 50' and meet exacting industry and load standards.

Legrand continues to provide contractors and end users with the specific products they need — from standard designs to custom-built products. With our national distribution partnerships and our manufacturing facilities in North America, we are perfectly positioned to supply any sized project — offering excellent service with the best lead times in the industry.



PW CABLE TRAY SYSTEMS

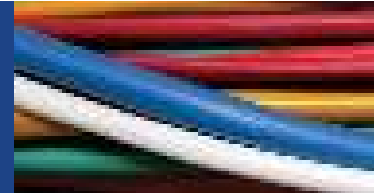

NEW ITRAY ALUMINUM LADDER, TROUGH AND SOLID BOTTOM SYSTEMS

Itray is the newest addition to the PW Line of cable tray products. It was designed to streamline the engineering, purchasing and installation of cable tray. Itray replaces our current "C" aluminum 4" to 7" side rail height cable tray line.

Itray's patent-pending, all-aluminum construction features a space saving I-beam design, a side rail engineered with structural offsets and a matching splice. The I-beam design minimizes total tray width and creates a smooth transition between straight sections and fittings. And Itray splices reduce hardware needs by 50%. These features allow Itray to be installed up to 30% faster than standard tray.



SPLICING MADE EASY

The structural offset side rail and splice design makes a splice that is strong and easy to install. The stronger splice allows mid-span splicing while maintaining full NEMA load class. This simplifies the design process and reduces the overall number of spliced sections that require jobsite fabrication. During installation the splice simply snaps in place and keeps tray sections aligned while the installer inserts and tightens 4 bolts. Itray's all aluminum construction features a space saving I-beam design,



a side rail engineered with structural offsets and a matching splice. The I-beam design minimizes total tray width and creates a smooth transition between straight sections and fittings. And Itray splices reduce hardware needs by 50%. These features allow Itray to be installed up to 30% faster than standard tray.

STRONGER I-BEAM RUNG DESIGN



Itray also features the strongest rungs in the industry. It's I-beam design reduces twist and deflection under load and heavier I-beam rungs are standard on wider tray without special order.

SMOOTHER FINISHED INSTALLATIONS

Itray straight sections and fittings match perfectly creating a smooth side rail edge for a natural cable pathway that makes pulling cable easier and with less chance of damage to the cable sheath. Itray features



a 3" tangent that follows industry standards and the symmetric side rail design allows smooth ceiling to wall transitions without the need for field fabrication. Transition splices are available for older, existing installations.



VIEW THIS VIDEO FOR A COMPLETE PRESENTATION ON ITRAY





METALLIC AND FIBERGLASS LADDER, TROUGH AND SOLID BOTTOM SYSTEMS

PW cable tray is a fabricated structure consisting of two side rails connected by individual rungs or bottom. Side rails are 4" to 10" high. Widths are 6" to 36". Bottom options include Ladder, Vented Corrugated Bottom, Solid Corrugated Bottom, and Flat-Sheet Solid Bottom designs.

A wide range of load and span designations are available for every possible application, from trays for commercial use where spans over 8' are required, to trays for longer spans required in industrial applications. Also available are trays built for extremely long spans – up to 50' – for special applications like roadway crossings and pipe bridges.

Our product line includes trays, fittings, covers, firewall penetration sleeves, and other accessories. These products are available in hot-dipped galvanized steel. For extremely corrosive applications we have product lines in 304 and 316 stainless steel or polyester and vinylester fiberglass.

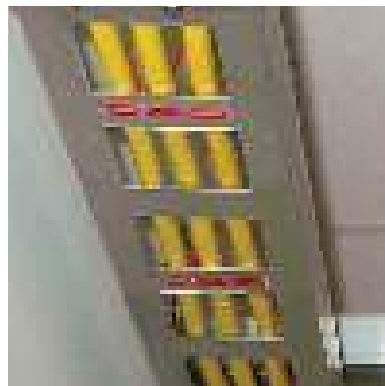

CHANNEL TRAY

Channel tray is a one-piece ventilated or solid-bottom cable tray with sizes up to 6" wide. It is commonly used for small runs of cable or for drops from main cable tray runs to equipment or junction boxes. These products are available in aluminum, mill galvanized steel and hot-dipped galvanized steel. For extremely corrosive applications we have products in 304 and 316 stainless steel or polyester and vinylester fiberglass. A complete line of accessories is available, including covers and fittings in 12" to 36" radius.



CABLE RUNWAY

Cable Runway is available in a lightweight version with tubular side rails and a solid bar side rail option for maximum support strength. Both styles have tubular steel rungs. Commonly used in telecommunication, voice, and data applications, runway is typically mounted directly above or to computer racking systems, enclosures, and relay rack cabinets. Cable Runway is available in yellow-zinc dichromate as required for UL Classified installations as an equipment ground conductor, and a range of powder-coated finishes.



PW CABLE TRAY

Understanding Our Products

TRAY OPTIONS

It is essential to consider the type and quantity of cables to be installed in the cable tray when planning your project. Refer to Article 392 of the National Electrical Code (NEC) for guidelines on calculating the cable tray depth and width.

LOAD DEPTH: Interior depth of the cable tray that is available for cable fill. Specifications for cable trays should include a specific requirement for the tray load depth. Due to design variations between different manufacturers, it is important to specify an exact load depth to ensure equal performance. The load depth may differ slightly based on choice of tray bottom.

WIDTH: Interior width of the tray or channel that is available for cable fill.

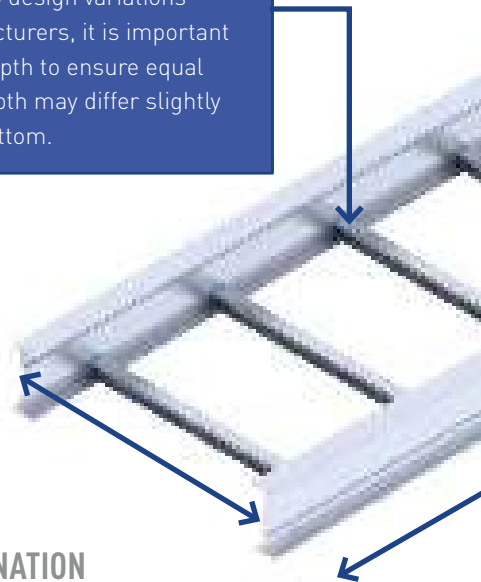

LOAD/SPAN CLASS DESIGNATION

THE LOAD/SPAN CLASSIFICATION describes the cable tray's load-carrying capability for a specific support span. A classification should be selected that reflects the actual working load and support span for each application. This designation directly affects the cost of the tray, so the proper selection is essential to determine the most economical cable tray system necessary for each project. Please consult with Legrand for working loads and support spans that fall outside the boundaries of the Load/Span Classes shown.

CONCENTRATED STATIC LOAD: In addition to an evenly distributed cable load, it is occasionally required that the cable tray system be capable of supporting a concentrated static load. A concentrated static load represents a static weight applied on the centerline of the cable tray at midspan. The concentrated static load in lbs. may be converted to an equivalent uniform load (We) in lbs./ft., using the following formula, and added to the static weight of cables in the tray. A NEMA Load Class can then be selected that reflects the combination of the cable load and converted static load.

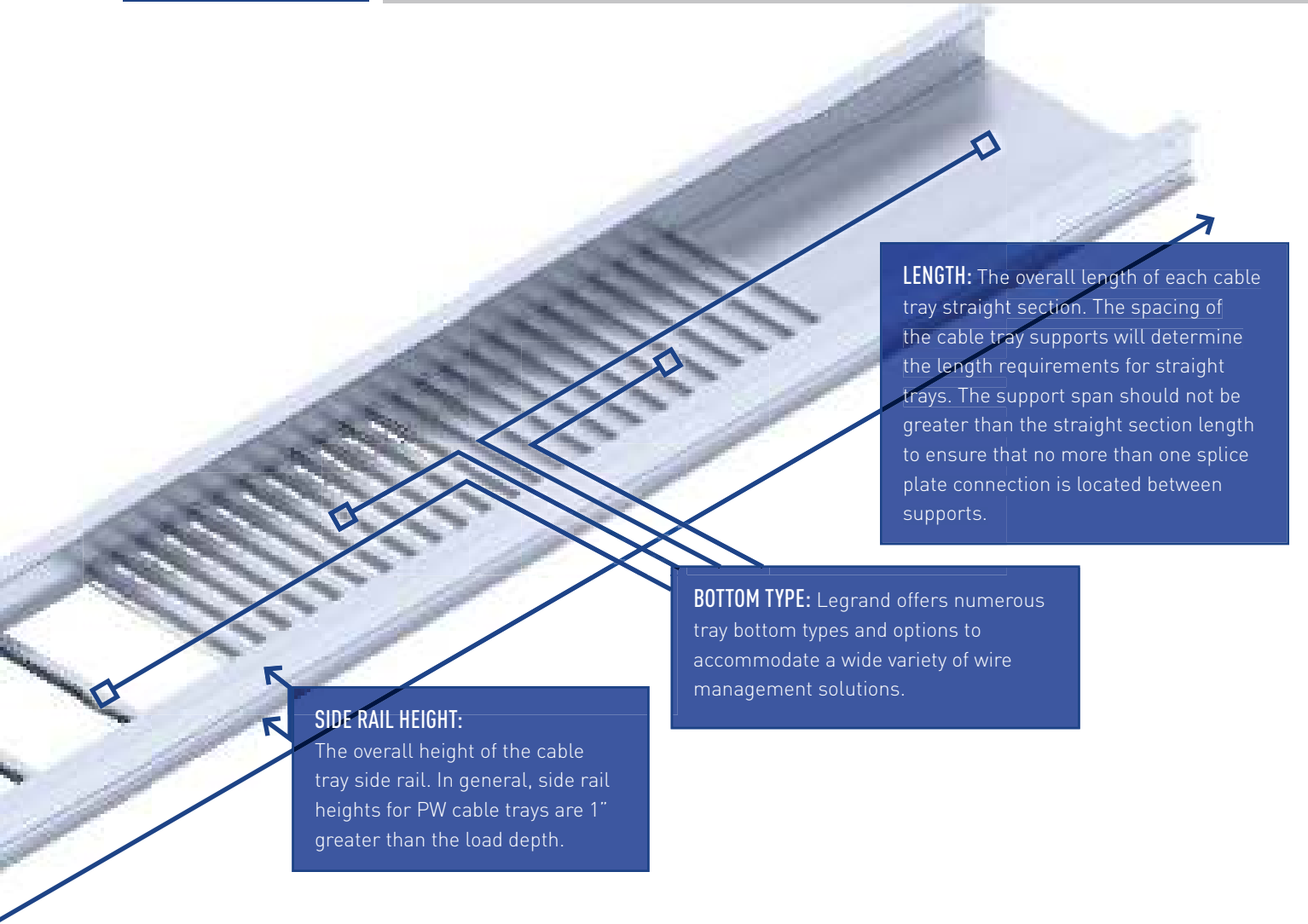

LENGTH: The overall length of each cable tray straight section. The spacing of the cable tray supports will determine the length requirements for straight trays. The support span should not be greater than the straight section length to ensure that no more than one splice plate connection is located between supports.

BOTTOM TYPE: Legrand offers numerous tray bottom types and options to accommodate a wide variety of wire management solutions.

SIDE RAIL HEIGHT: The overall height of the cable tray side rail. In general, side rail heights for PW cable trays are 1" greater than the load depth.

$$W_e = \frac{2 \times (\text{concentrated static load, lbs.})}{\text{support span length, ft.}}$$

Example: A 200 lb. concentrated load is to be applied to a cable tray that is supported on a 12 ft. support span. Using the formula above, the equivalent uniform load $W_e = 2 \times 200 / 12 = 33$ lbs. per linear foot. This should be added to the anticipated cable load to determine the appropriate Load/Span Class for the cable tray.

Note: To accommodate concentrated loads, some circumstances may require cable trays to have reinforced side rails or bottom members. Therefore, it is recommended that you consult with Legrand when considering concentrated loads or any other special cable tray loading requirements.

LOAD/SPAN CLASS DESIGNATIONS				
WORKING LOAD lbs/ft (kg/m)	SUPPORT SPAN, ft. (m)			
	8 ft. (2.4 m)	10 ft. (3.0 m)	12 ft. (3.7 m)	20 ft. (6.0 m)
25 (37)	—	A	—	—
45 (67)	—	—	—	D
50 (74)	8A	—	12A	20A
65 (97)	—	C	—	—
75 (112)	8B	—	12B	E or 20B
100 (149)	8C	—	12C	20C
120 (179)	—	D	—	—
200 (299)	—	E	—	—

WORKING LOAD: Total load of cables installed and uniformly distributed in the cable tray.

SUPPORT SPAN: Maximum distance between cable tray supports.

CLASSES 8, 12, 20 / A, B, C: NEMA designations, published by the National Electrical Manufacturers Assoc. in Standard VE1.

CLASSES A, C, D, AND E: CSA designations, published by the Canadian Standards Association in Standard C22.2, No. 126.



PW CABLE TRAY

FITTINGS, ACCESSORIES AND HARDWARE

A complete cable tray system includes fittings, accessories, supports, and hardware. Consider the following components when designing a cable tray system:

FITTING RADIUS: The nominal bend radius for fittings should not be less than the minimum allowable bending radius for the cables to be installed in the tray. Cable manufacturers typically publish the minimum bending radius as a multiple of the cable diameter.

EXPANSION CONNECTORS AND SUPPORTS: It is important to consider thermal expansion and contraction in the cable tray system, especially for outdoor applications. NEMA Standards Pub. VE2 addresses the proper installation and spacing of expansion connectors, expansion guides, hold down clamps, tray supports, and bonding jumpers.

COVERS: Cable tray covers are often needed to contain and protect tray contents. Carefully select a specific cover design and specify the proper attachment hardware needed for indoor, outdoor, or vertical installations.

DIVIDERS: In some applications, the NEC requires the use of tray dividers to separate cables. Multiple dividers can also easily help manage complex wiring systems.

GROUNDING: All aluminum and galvanized steel cable trays manufactured by Legrand are classified by UL as equipment grounding conductors with specific ampere ratings per NEC 392. To maintain electrical continuity, bonding jumpers should be installed at mechanically discontinuous locations and sized in accordance with the rating of the cable tray system.

HARDWARE: Screws, nuts, bolts, etc. for assembling cable tray connectors and accessories are normally provided in zinc plated or geomet steel, adequate for most applications. Some moist, outdoor, or corrosive environments may require the use of stainless steel hardware for better performance. All PW cable tray connectors and most accessories are available with optional Type 316 stainless steel hardware.

Ordering

Our Products

MATERIALS

The selection of cable tray material depends on many factors including environmental conditions, corrosion resistance, aesthetics, and material handling.

		DRY INTERIORS	EXTERIORS	CORROSIVE	HIGHLY CORROSIVE	FASTENER FINISHES
A	ALUMINUM; MARINE GRADE; COPPER FREE ALLOYS 6063-T6, 5052-H32 & 3003	●	●			ZN GE S6
M	MILL GALVANIZED STEEL (Before Fabrication) ASTM A653 G90	●				ZN CD
Z	ELECTRO-GALVANIZED STEEL ASTM B633 SC2	●				ZN CD
G	HOT-DIP GALVANIZED STEEL (After Fabrication) ASTM A123		●	●		CD S6
L	STAINLESS STEEL AISI Type 304L			●		S4 S6
T	STAINLESS STEEL AISI Type 316L			●	●	S6
F	FIBERGLASS ASTM E-84 Class 1				●	S6 FG FE
PE	SPECIAL FINISHES ASTM D3451 (for powder paint only)	●	●	●		
C	COPPER					
N	NYLON					
V	VINYL					

● Recommended ● Possible

SPECIFYING YOUR ORDER

Itray Aluminum Tray

The numbering system for Itray Aluminum 4" to 7" tray is new and easier to use. Please review these examples before specifying your order.

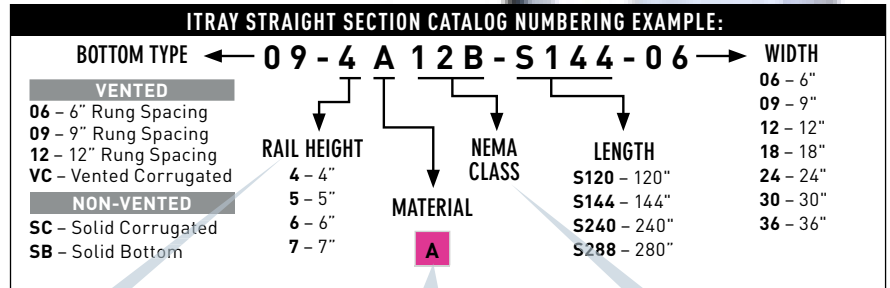

Overall rail height is clearly marked with 4" to 7" heights available.

The tray material is listed as well. Currently Itray will only be offered in Aluminum. Stronger I-beam construction means no series choice is needed.

The tray system number is the same as the NEMA Class - no cross-reference needed.

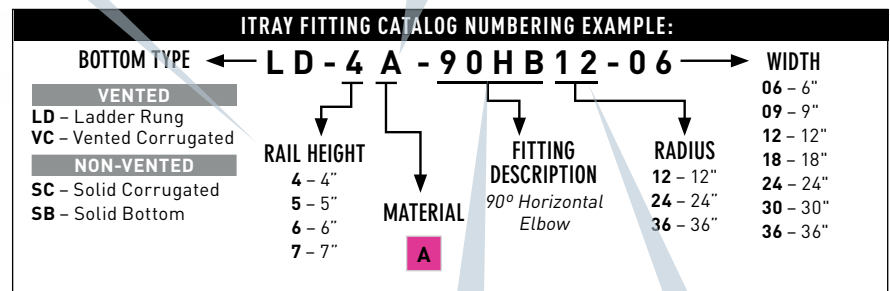

No complicated Fitting System Number or Product Number. The Fitting Description is now an abbreviated form of the product name.

Radius measurement is now clearly shown.



Look for the Itray Compatible designation throughout the Ladder, Trough and Solid Bottom section of this catalog for products that also fit Itray specifications.

The numbering system for all other tray lines has not changed.

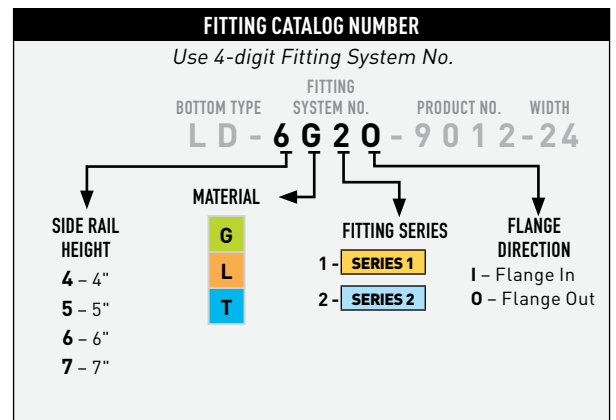
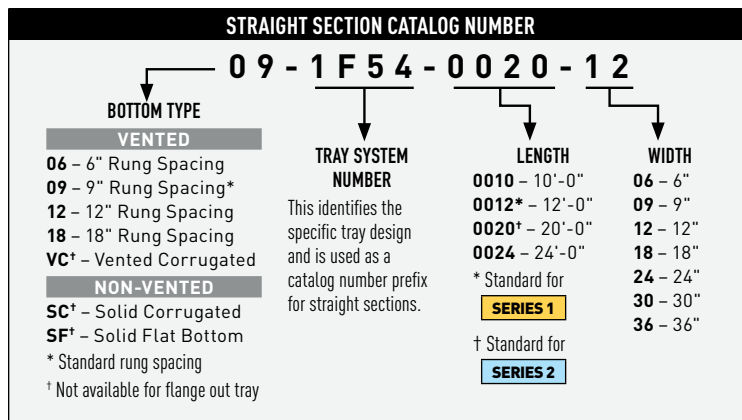

LADDER, TROUGH & SOLID BOTTOM

ITRAY ALUMINUM TRAY

- B.10 STRAIGHT SECTIONS**
- B.12 FITTINGS**
- B.20 COVERS**
- B.22 SPLICES & CONNECTORS**
- B.24 ACCESSORIES**

METALLIC

- B.26 LONG-SPAN TRAY**
- B.28 STEEL TRAY**
- B.30 STAINLESS STEEL TRAY**
- B.32 FITTINGS**
- B.42 COVERS**
- B.45 SPLICES & CONNECTORS**
- B.49 ACCESSORIES**
- B.58 FIRESTOP SYSTEMS**
- B.60 REFERENCE INFORMATION**
- B.63 RUNG OPTIONS**

FIBERGLASS

- B.70 STRAIGHT SECTIONS**
- B.72 FITTINGS**
- B.76 COVERS**
- B.77 SPLICES & CONNECTORS**
- B.78 ACCESSORIES**



The PW Line of cable tray products is offered in a wide variety of sizes, designs and finishes to meet exacting industry standards. Choose from our extensive selection of rail, rung and bottom styles that are available in a variety of finishes. Also choose from fittings, accessories, fire stop systems and fasteners that will complete your installation.

Legrand representatives have the experience to insure that your cable management needs will be fulfilled on time and to your specifications.

MC POWER CABLE FILL TABLE

LADDER TRAY	MAX NUMBER OF CABLES PER CODE*			
	THHN TypeMC AlumArmor			
	2C (12 AWG)	3C (12 AWG)	3C (AWG 4/0)	3C (500 kcmil)
6	35 cbls	31 cbls	3 cbls	2 cbls
9	52 cbls	45 cbls	5 cbls	3 cbls
12	71 cbls	63 cbls	7 cbls	5 cbls
18	107 cbls	94 cbls	11 cbls	7 cbls
24	143 cbls	126 cbls	15 cbls	10 cbls
30	178 cbls	157 cbls	18 cbls	12 cbls
36	214 cbls	204 cbls	22 cbls	15 cbls

* Vented cable tray only.



TRAY MATERIAL	SIDE RAIL HEIGHTS INCHES	VENTED		NON-VENTED	
		LADDER STANDARD RUNG	VENTILATED TROUGH CORRUGATED	SOLID BOTTOM CORRUGATED	SOLID BOTTOM FLAT SHEET
A ALUMINUM ITRAY	4 5 6 7	6", 9" and 12" rung spacing	7/8" wide ribs are 1/2" deep on 2" centers with air vents	7/8" wide ribs are 1/2" deep on 2" centers	Flat sheet over 12" rung spacing
A ALUMINUM G HOT-DIP GALVANIZED STEEL LONG-SPAN	8 10	9", 12" and 18" rung spacing	N/A	N/A	N/A
G HOT-DIP GALVANIZED STEEL STEEL	4 5 6 7	6", 9" and 12" rung spacing	7/8" wide ribs are 1/2" deep on 2" centers with air vents	7/8" wide ribs are 1/2" deep on 2" centers	N/A
L STAINLESS STEEL 304L T STAINLESS STEEL 316L STAINLESS STEEL	4 5 6 7	6", 9" and 12" rung spacing	N/A	N/A	Flat sheet only
F FIBERGLASS FIBERGLASS	4 6	6", 9" and 12" rung spacing	N/A	N/A	Flat sheet under 12" rung spacing

DATA CABLE FILL TABLE

LADDER TRAY		MAX NUMBER OF CABLES PER CODE			
WIDTH (IN.)	LOAD DEPTH (IN.)	Cat 5e 4-pr Plenum (.17 IN.)	Cat 5e 4-pr Non-Plenum (.19 IN.)	Cat 6e 4-pr Plenum (.22 IN.)	Cat 6a 4-pr Plenum (.30 IN.)
6	3	396 cbls	317 cbls	236 cbls	127 cbls
9	3	594 cbls	476 cbls	355 cbls	190 cbls
12	3	793 cbls	634 cbls	473 cbls	254 cbls
18	3	1189 cbls	952 cbls	710 cbls	381 cbls
24	3	1586 cbls	1269 cbls	947 cbls	509 cbls
30	3	1982 cbls	1587 cbls	1183 cbls	636 cbls
36	3	2379 cbls	1904 cbls	1420 cbls	763 cbls
6	4	527 cbls	422 cbls	314 cbls	169 cbls
9	4	803 cbls	643 cbls	480 cbls	258 cbls
12	4	1055 cbls	844 cbls	629 cbls	338 cbls
18	4	1582 cbls	1266 cbls	944 cbls	508 cbls
24	4	2110 cbls	1689 cbls	1259 cbls	677 cbls
30	4	2679 cbls	2145 cbls	1600 cbls	860 cbls
36	4	3215 cbls	2574 cbls	1920 cbls	1032 cbls

LADDER TRAY		MAX NUMBER OF CABLES PER CODE			
WIDTH (IN.)	LOAD DEPTH (IN.)	Cat 5e 4-pr Plenum (.17 IN.)	Cat 5e 4-pr Non-Plenum (.19 IN.)	Cat 6e 4-pr Plenum (.22 IN.)	Cat 6a 4-pr Plenum (.30 IN.)
6	5	660 cbls	529 cbls	394 cbls	212 cbls
9	5	991 cbls	793 cbls	591 cbls	318 cbls
12	5	1321 cbls	1058 cbls	789 cbls	424 cbls
18	5	1982 cbls	1587 cbls	1183 cbls	636 cbls
24	5	2643 cbls	2116 cbls	1578 cbls	848 cbls
30	5	3304 cbls	2645 cbls	1972 cbls	1061 cbls
36	5	3965 cbls	3174 cbls	2367 cbls	1273 cbls
6	6	788 cbls	631 cbls	469 cbls	277 cbls
9	6	1189 cbls	952 cbls	710 cbls	381 cbls
12	6	1515 cbls	1213 cbls	905 cbls	486 cbls
18	6	2273 cbls	1820 cbls	1357 cbls	730 cbls
24	6	3031 cbls	2427 cbls	1810 cbls	973 cbls
30	6	3965 cbls	3174 cbls	2367 cbls	1273 cbls
36	6	4758 cbls	3809 cbls	2841 cbls	1527 cbls



ITRAY

A ALUMINUM

CONNECTORS & FITTINGS:

Necessary connectors and fasteners are supplied with all trays and fittings. Extra connectors for field cuts or spares must be ordered separately.

SAFE LOAD:

Allowable cable load in pounds per linear foot uniformly distributed. Based on tray with standard rung on 9" centers and supported on simple beam with safety factor of 1.5 per NEMA VE1.

CONCENTRATED LOAD:

All ladders with solid rungs and trays with corrugated bottoms will support a 200 lb. concentrated load applied at the center of the tray in addition to the NEMA-rated cable load without collapse.

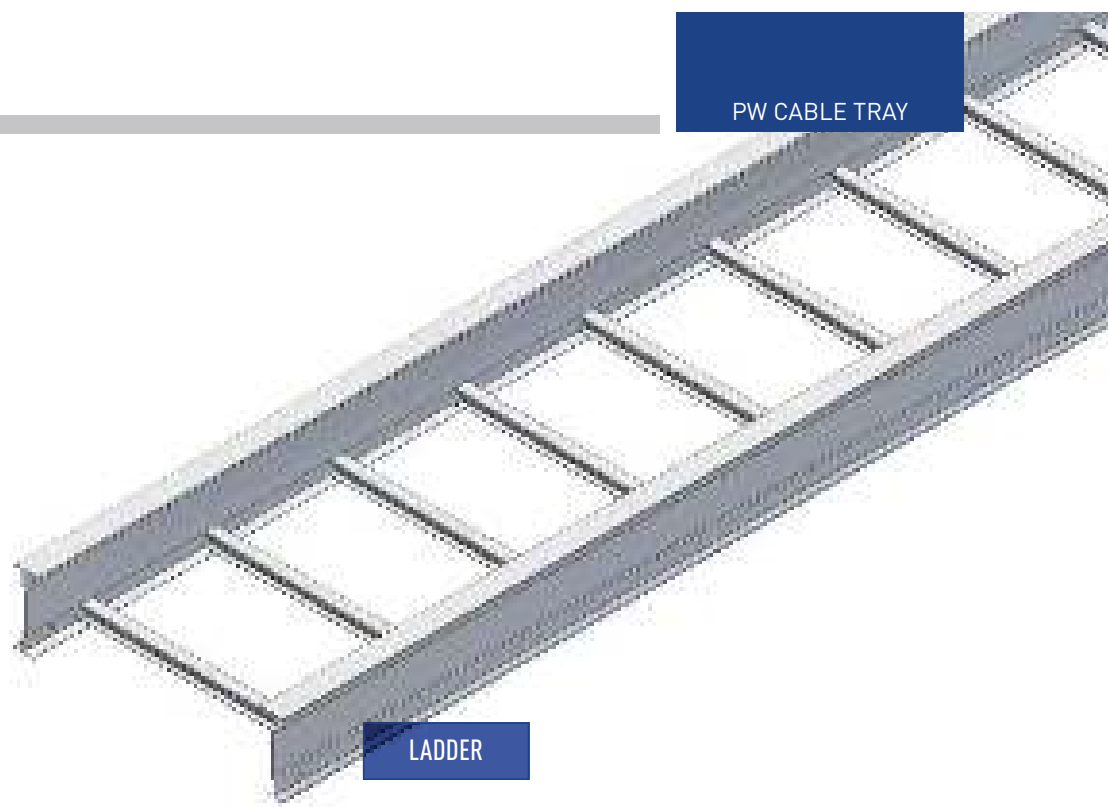

RAIL HEIGHT (IN.)	LOAD DEPTH (IN.)	NEMA CLASS	AVAILABLE LENGTHS (FT.)						WIDTHS (IN.)	TRAY SYSTEM NUMBER	AMP RATING
			10	12	20	24	30	36			
4	3	12B	10	12	-	-	-	6-36	4A12B	1200	
	3	12C	10	12	20	-	-	6-36	4A12C	1200	
	3	20B	-	12	20	24	-	6-36	4A20B	2000	
5	4	12C	10	12	20	-	-	6-36	5A12C	1200	
	4	20B	-	12	20	24	-	6-36	5A20B	1600	
6	5	12C	10	12	20	-	-	6-36	6A12C	1200	
	5	20B	-	12	20	24	-	6-36	6A20B	1600	
	5	20C	-	12	20	24	-	6-36	6A20C	2000	
	5	24C	-	-	20	24	30	6-36	6A24C	2000	
7	6	12C	10	12	20	-	-	6-36	7A12C	1600	
	6	20B	-	12	20	24	-	6-36	7A20B	2000	
	6	20C	-	12	20	24	-	6-36	7A20C	2000	
	6	24C	-	-	20	24	30	6-36	7A24C	2000	

ITRAY - STRAIGHT SECTIONS

WIDTHS (W) INCHES
6 | 9 | 12 | 18 | 24 | 30 | 36

RAIL HEIGHTS (H) INCHES
4 | 5 | 6 | 7



90HB
HORIZONTAL 90° ELBOW

A



BOTTOM TYPES



LD and SB

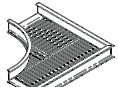

VC and SC

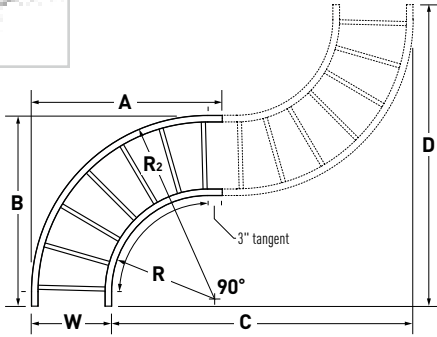

60HB
HORIZONTAL 60° ELBOW

A

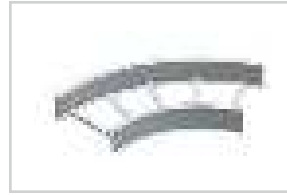

BOTTOM TYPES



LD and SB



VC and SC

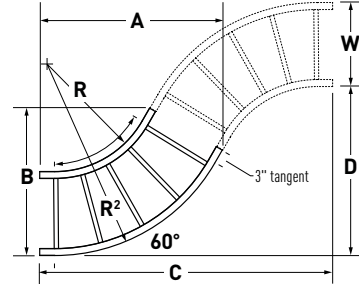

RADIUS R	WIDTH W	RADIUS 2 R2	A	B	C	D
12	6	18	21	21	36	36
	9	21	24	24	39	39
	12	24	27	27	42	42
	18	30	33	33	48	48
	24	36	39	39	54	54
	30	42	45	45	60	60
	36	48	51	51	66	66
24	6	30	33	33	60	60
	9	33	36	36	63	63
	12	36	39	39	66	66
	18	42	45	45	72	72
	24	48	51	51	78	78
	30	54	57	57	84	84
	36	60	63	63	90	90
36	6	42	45	45	84	84
	9	45	48	48	87	87
	12	48	51	51	90	90
	18	54	57	57	96	96
	24	60	63	63	102	102
	30	66	69	69	108	108
	36	72	75	75	114	114

RADIUS R	WIDTH W	RADIUS 2 R2	A	B	C	D
12	6	18	20 ¹ / ₈	14 ⁵ / ₈	35	20 ¹ / ₈
	9	21	22 ⁵ / ₈	17 ⁵ / ₈	37 ⁵ / ₈	21 ³ / ₈
	12	24	25 ¹ / ₄	20 ⁵ / ₈	40 ¹ / ₈	23 ¹ / ₄
	18	30	30 ¹ / ₂	26 ⁵ / ₈	45 ⁵ / ₈	26 ¹ / ₄
	24	36	35 ⁵ / ₈	32 ⁵ / ₈	50 ⁵ / ₈	29 ¹ / ₄
	30	42	40 ⁷ / ₈	38 ⁵ / ₈	55 ³ / ₄	32 ¹ / ₄
	36	48	46 ¹ / ₈	44 ⁵ / ₈	61	35 ¹ / ₄
24	6	30	30 ¹ / ₂	20 ⁵ / ₈	55 ³ / ₄	32 ¹ / ₄
	9	33	33 ¹ / ₈	23 ⁵ / ₈	58 ³ / ₈	33 ³ / ₄
	12	36	35 ⁵ / ₈	26 ⁵ / ₈	61	35 ¹ / ₄
	18	42	40 ⁷ / ₈	32 ⁵ / ₈	66 ¹ / ₈	38 ¹ / ₄
	24	48	46 ¹ / ₈	38 ⁵ / ₈	71 ³ / ₈	41 ¹ / ₄
	30	54	51 ¹ / ₄	44 ⁵ / ₈	76 ¹ / ₂	44 ¹ / ₄
	36	60	56 ¹ / ₂	50 ⁵ / ₈	81 ³ / ₄	47 ¹ / ₄
36	6	42	40 ⁷ / ₈	26 ⁵ / ₈	76 ¹ / ₂	44 ¹ / ₄
	9	45	43 ¹ / ₂	29 ⁵ / ₈	79 ¹ / ₈	45 ³ / ₄
	12	48	46 ¹ / ₈	32 ⁵ / ₈	81 ³ / ₄	47 ¹ / ₄
	18	54	51 ¹ / ₄	38 ⁵ / ₈	87	50 ¹ / ₄
	24	60	56 ¹ / ₂	44 ⁵ / ₈	92 ¹ / ₈	53 ¹ / ₄
	30	66	61 ⁵ / ₈	50 ⁵ / ₈	97 ³ / ₈	56 ¹ / ₄
	36	72	66 ⁷ / ₈	56 ⁵ / ₈	102 ¹ / ₂	59 ¹ / ₄

WIDTHS (W) INCHES

6 | 9 | 12 | 18 | 24 | 30 | 36

RAIL HEIGHTS (H) INCHES

4 | 5 | 6 | 7

RADIUS (R) INCHES

12 | 24 | 36

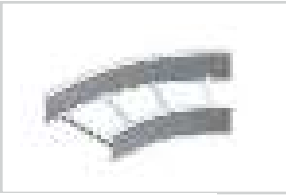

45HB HORIZONTAL 45° ELBOW

A

BOTTOM TYPES

LD and SB

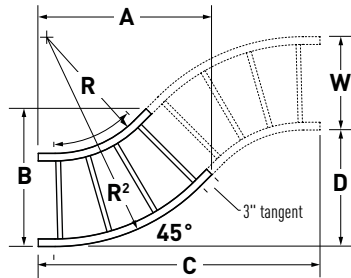

VC and SC



30HB HORIZONTAL 30° ELBOW

A

BOTTOM TYPES

LD and SB



VC and SC

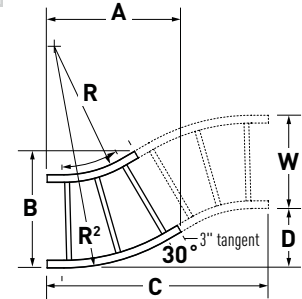

RADIUS R	WIDTH W	RADIUS 2 R2	A	B	C	D
12	6	18	17 ⁷ / ₈	11 ⁵ / ₈	31 ¹ / ₂	13
	9	21	20	14 ⁵ / ₈	33 ⁵ / ₈	13 ⁷ / ₈
	12	24	22 ¹ / ₈	17 ⁵ / ₈	35 ³ / ₄	14 ¹ / ₄
	18	30	26 ³ / ₈	23 ⁵ / ₈	40	16 ¹ / ₂
	24	36	30 ⁵ / ₈	29 ⁵ / ₈	44 ¹ / ₈	18 ¹ / ₄
	30	42	34 ⁷ / ₈	35 ⁵ / ₈	48 ³ / ₈	20
24	6	30	26 ³ / ₈	15 ¹ / ₈	48 ³ / ₈	20
	9	33	28 ¹ / ₂	18 ¹ / ₈	50 ¹ / ₂	21
	12	36	30 ⁵ / ₈	21 ¹ / ₈	52 ⁵ / ₈	21 ⁷ / ₈
	18	42	34 ⁷ / ₈	27 ¹ / ₈	56 ⁷ / ₈	23 ⁵ / ₈
	24	48	39	33 ¹ / ₈	61 ¹ / ₈	25 ³ / ₈
	30	54	43 ¹ / ₄	39 ¹ / ₈	65 ³ / ₈	27 ¹ / ₈
36	6	42	34 ⁷ / ₈	18 ⁵ / ₈	65 ³ / ₈	27 ¹ / ₈
	9	45	37	21 ⁵ / ₈	67 ¹ / ₂	28
	12	48	39	24 ⁵ / ₈	69 ⁵ / ₈	28 ⁷ / ₈
	18	54	43 ¹ / ₄	30 ⁵ / ₈	73 ⁷ / ₈	30 ⁵ / ₈
	24	60	47 ¹ / ₂	36 ⁵ / ₈	78 ¹ / ₈	32 ³ / ₈
	30	66	51 ³ / ₄	42 ⁵ / ₈	82 ³ / ₈	34 ¹ / ₈
36	72	56	48 ⁵ / ₈	86 ⁵ / ₈	35 ⁷ / ₈	

RADIUS R	WIDTH W	RADIUS 2 R2	A	B	C	D
12	6	18	14 ¹ / ₂	9 ¹ / ₈	26 ¹ / ₄	7
	9	21	16 ¹ / ₈	12 ¹ / ₈	27 ³ / ₄	7 ³ / ₈
	12	24	17 ⁵ / ₈	15 ¹ / ₈	29 ¹ / ₄	7 ⁷ / ₈
	18	30	20 ⁵ / ₈	21 ¹ / ₈	32 ¹ / ₄	8 ⁵ / ₈
	24	36	23 ³ / ₈	27 ¹ / ₈	35 ¹ / ₄	9 ³ / ₈
	30	42	26 ⁵ / ₈	33 ¹ / ₈	38 ¹ / ₄	10 ¹ / ₄
24	6	30	20 ⁵ / ₈	10 ³ / ₄	38 ¹ / ₄	10 ¹ / ₄
	9	33	22 ¹ / ₈	13 ³ / ₄	39 ³ / ₄	10 ⁵ / ₈
	12	36	23 ⁵ / ₈	16 ³ / ₄	41 ¹ / ₄	11
	18	42	26 ⁵ / ₈	22 ¹ / ₄	44 ¹ / ₄	11 ⁷ / ₈
	24	48	29 ⁵ / ₈	28 ³ / ₄	47 ¹ / ₄	12 ⁵ / ₈
	30	54	32 ³ / ₈	34 ³ / ₄	50 ¹ / ₄	13 ¹ / ₂
36	6	42	26 ⁵ / ₈	12 ³ / ₈	50 ¹ / ₄	13 ¹ / ₂
	9	45	28 ¹ / ₈	15 ³ / ₈	51 ³ / ₄	13 ³ / ₈
	12	48	29 ⁵ / ₈	18 ³ / ₈	53 ¹ / ₄	14 ¹ / ₄
	18	54	32 ³ / ₈	24 ³ / ₈	56 ¹ / ₄	15
	24	60	35 ³ / ₈	30 ³ / ₈	59 ¹ / ₄	15 ³ / ₈
	30	66	38 ³ / ₈	36 ³ / ₈	62 ¹ / ₄	16 ⁵ / ₈
36	72	41 ³ / ₈	42 ³ / ₈	65 ¹ / ₄	17 ¹ / ₂	

ITRAY HORIZONTAL ELBOW CATALOG NUMBERING EXAMPLE:

	← BOTTOM TYPE ←	LD - 4 A - 90HB 12 - 06	→ WIDTH
	VENTED		06 - 6"
	LD - Ladder Rung		09 - 9"
	VC - Vented Corrugated		12 - 12"
	NON-VENTED		18 - 18"
	SC - Solid Corrugated		24 - 24"
	SB - Solid Bottom		30 - 30"
		RAIL HEIGHT	36 - 36"
		4 - 4"	
		5 - 5"	
		6 - 6"	
		7 - 7"	
		FITTING CODE	
		90HB	
		60HB	
		45HB	
		30HB	
		RADIUS	
		12 - 12"	
		24 - 24"	
		36 - 36"	
		MATERIAL	
		A	



SR / LR / RR
HORIZONTAL REDUCERS

A

STRAIGHT

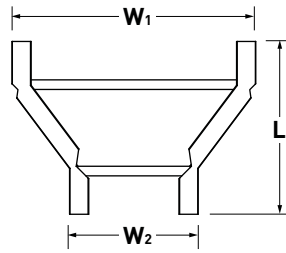

LEFT HAND

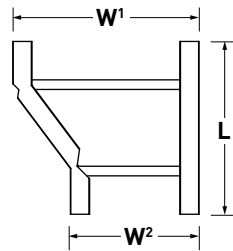

RIGHT HAND

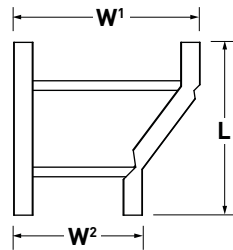

LENGTH	MAIN WIDTH W1	AVAILABLE BRANCH WIDTHS W2					
		6	9	12	18	24	30
18	9	6	-	-	-	-	-
	12	6	9	-	-	-	-
	18	6	9	12	-	-	-
	24	6	9	12	18	-	-
	30	6	9	12	18	24	-
	36	6	9	12	18	24	30

HT
HORIZONTAL STANDARD TEE

A

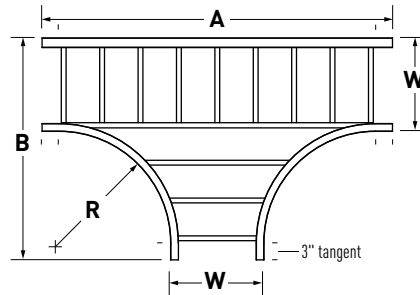
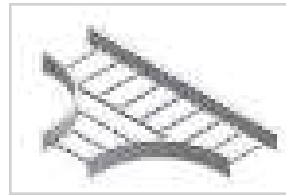

RADIUS R	WIDTH W	A	B
12	6	36	21 5/8
	9	39	24 5/8
	12	42	27 5/8
	18	48	33 5/8
	24	54	39 5/8
	30	60	45 5/8
24	6	60	33 5/8
	9	63	36 5/8
	12	66	39 5/8
	18	72	45 5/8
	24	78	51 5/8
	30	84	57 5/8
36	6	84	45 5/8
	9	87	48 5/8
	12	90	51 5/8
	18	96	57 5/8
	24	102	63 5/8
	30	108	69 5/8
	36	114	75 5/8

ITRAY HORIZONTAL REDUCER CATALOG NUMBERING EXAMPLE:

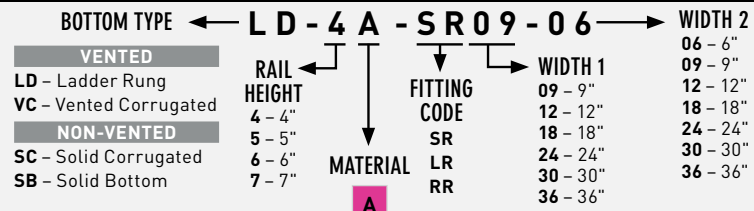

RT / ET HORIZONTAL REDUCING/EXPANDING TEES

A

REDUCING TEE

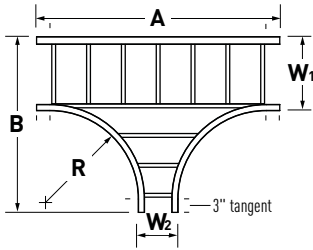
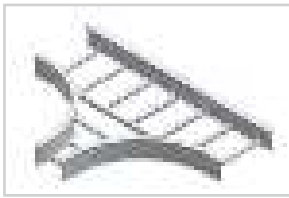

MAIN WIDTH W1	BRANCH WIDTH W2	RADIUS R	A	B	RADIUS R	A	B	RADIUS R	A	B
9	6	12	36	24 ⁵ / ₈	24	60	36 ⁵ / ₈	36	84	48 ⁵ / ₈
12	6		36	27 ⁵ / ₈		60	39 ⁵ / ₈		84	51 ⁵ / ₈
	9		39	27 ⁵ / ₈		63	39 ⁵ / ₈		87	51 ⁵ / ₈
18	6		36	33 ⁵ / ₈		60	45 ⁵ / ₈		84	57 ⁵ / ₈
	9		39	33 ⁵ / ₈		63	45 ⁵ / ₈		87	57 ⁵ / ₈
	12		42	33 ⁵ / ₈		66	45 ⁵ / ₈		90	57 ⁵ / ₈
24	6		36	39 ⁵ / ₈		60	51 ⁵ / ₈		84	63 ⁵ / ₈
	9		39	39 ⁵ / ₈		63	51 ⁵ / ₈		87	63 ⁵ / ₈
	12		42	39 ⁵ / ₈		66	51 ⁵ / ₈		90	63 ⁵ / ₈
30	18		48	39 ⁵ / ₈		72	51 ⁵ / ₈		96	63 ⁵ / ₈
	6		36	45 ⁵ / ₈		60	57 ⁵ / ₈		84	69 ⁵ / ₈
	9		39	45 ⁵ / ₈		63	57 ⁵ / ₈		87	69 ⁵ / ₈
	12	42	45 ⁵ / ₈	66	57 ⁵ / ₈	90	69 ⁵ / ₈			
36	18	48	45 ⁵ / ₈	72	57 ⁵ / ₈	96	69 ⁵ / ₈			
	6	36	51 ⁵ / ₈	60	63 ⁵ / ₈	84	75 ⁵ / ₈			
	9	39	51 ⁵ / ₈	63	63 ⁵ / ₈	87	75 ⁵ / ₈			
	12	42	51 ⁵ / ₈	66	63 ⁵ / ₈	90	75 ⁵ / ₈			
36	18	48	51 ⁵ / ₈	72	63 ⁵ / ₈	96	75 ⁵ / ₈			
	24	54	51 ⁵ / ₈	78	63 ⁵ / ₈	102	75 ⁵ / ₈			
	30	60	51 ⁵ / ₈	84	63 ⁵ / ₈	108	75 ⁵ / ₈			
	30	60	51 ⁵ / ₈	84	63 ⁵ / ₈	108	75 ⁵ / ₈			

EXPANDING TEE

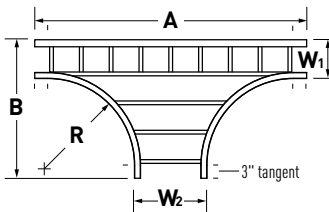

MAIN WIDTH W1	BRANCH WIDTH W2	RADIUS R	A	B	RADIUS R	A	B	RADIUS R	A	B
6	9	12	39	21 ⁵ / ₈	24	63	33 ⁵ / ₈	36	87	45 ⁵ / ₈
	12		42	21 ⁵ / ₈		66	33 ⁵ / ₈		90	45 ⁵ / ₈
	18		48	21 ⁵ / ₈		72	33 ⁵ / ₈		96	45 ⁵ / ₈
	24		54	21 ⁵ / ₈		78	33 ⁵ / ₈		102	45 ⁵ / ₈
	30		60	21 ⁵ / ₈		84	33 ⁵ / ₈		108	45 ⁵ / ₈
	36		66	21 ⁵ / ₈		90	33 ⁵ / ₈		114	45 ⁵ / ₈
9	12		42	24 ⁵ / ₈		66	36 ⁵ / ₈		90	48 ⁵ / ₈
	18		48	24 ⁵ / ₈		72	36 ⁵ / ₈		96	48 ⁵ / ₈
	24		54	24 ⁵ / ₈		78	36 ⁵ / ₈		102	48 ⁵ / ₈
	30		60	24 ⁵ / ₈		84	36 ⁵ / ₈		108	48 ⁵ / ₈
12	36		66	24 ⁵ / ₈		90	36 ⁵ / ₈		114	48 ⁵ / ₈
	18		48	27 ⁵ / ₈		72	39 ⁵ / ₈		96	51 ⁵ / ₈
	24	54	27 ⁵ / ₈	78	39 ⁵ / ₈	102	51 ⁵ / ₈			
	30	60	27 ⁵ / ₈	84	39 ⁵ / ₈	108	51 ⁵ / ₈			
18	36	66	27 ⁵ / ₈	90	39 ⁵ / ₈	114	51 ⁵ / ₈			
	24	54	33 ⁵ / ₈	78	45 ⁵ / ₈	102	57 ⁵ / ₈			
	30	60	33 ⁵ / ₈	84	45 ⁵ / ₈	108	57 ⁵ / ₈			
	36	66	33 ⁵ / ₈	90	45 ⁵ / ₈	114	57 ⁵ / ₈			
24	30	60	39 ⁵ / ₈	84	51 ⁵ / ₈	108	63 ⁵ / ₈			
	36	66	39 ⁵ / ₈	90	51 ⁵ / ₈	114	63 ⁵ / ₈			
30	36	66	45 ⁵ / ₈	90	57 ⁵ / ₈	114	69 ⁵ / ₈			

* Reducing/expanding tees are not available with the corrugated bottom type. Use reducer fittings (see page 14) or reducer splice plates (see page 23) in conjunction with horizontal standard tee fittings which are available with corrugated bottoms.

ITRAY HORIZONTAL TEE CATALOG NUMBERING EXAMPLE:

BOTTOM TYPE ← **LD - 4 A - RT 12 - 12 0 6** → **WIDTH 2"**

VENTED	RAIL HEIGHT	FITTING CODE	RADIUS	WIDTH 1	06 - 6"
LD - Ladder Rung					09 - 9"
NON-VENTED	4 - 4"	HT*	12 - 12"	18 - 18"	24 - 24"
SB - Solid Bottom	5 - 5"	RT	24 - 24"	30 - 30"	36 - 36"
	6 - 6"	ET	36 - 36"	30 - 30"	
	7 - 7"			36 - 36"	

MATERIAL A

* Width 2 does not apply to Horizontal Tee (HT).



YL / YR
HORIZONTAL WYE BRANCHES

A

LEFT HAND



RIGHT HAND

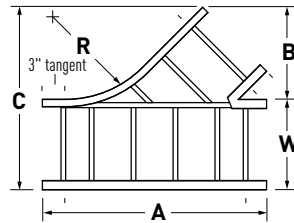

WIDTH W	RADIUS R	A	B	C
6	24	31 1/4	12	18
9		35 1/2	14 1/8	23 1/8
12		39 5/8	16 1/4	28 1/4
18		48 1/4	20 1/2	38 1/2
24		56 3/8	24 3/4	48 3/4
30		65 1/4	29	59
36	73 5/8	33 3/4	69 1/4	

HX
HORIZONTAL STANDARD CROSS

A

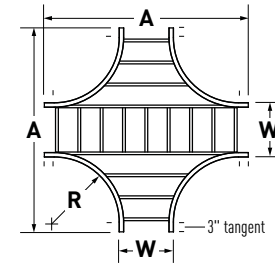
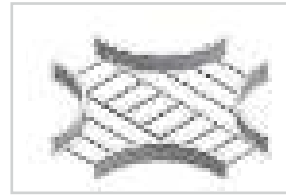

WIDTH W	RADIUS R	A	RADIUS R	A	RADIUS R	A
6	12	36	24	60	36	84
9		39		63		87
12		42		66		90
18		48		72		96
24		54		78		102
30		60		84		108
36	66	90	90	114		

RX
HORIZONTAL REDUCING CROSS

A

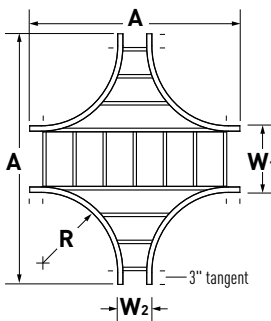
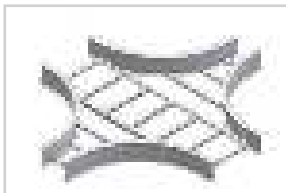

MAIN WIDTH W1	BRANCH WIDTH W2	RADIUS R	A	B	RADIUS R	A	B	RADIUS R	A	B
9	6	12	36	39	24	60	63	36	84	87
	12		6	36		42	60		66	84
9			39	42		63	66		87	90
18	6		36	48		60	72		84	96
	9		39	48		63	72		87	96
12	12		42	48		66	72		90	96
	24		6	36		54	60		78	84
9			39	54		63	78		87	102
12	12		42	54		66	78		90	102
	18		48	54		72	78		96	102
30	6		36	60		60	84		84	108
	9		39	60		63	84		87	108
12	12	42	60	66	84	90	108			
	18	48	60	72	84	96	108			
24	18	54	60	78	84	102	108			
	30	60	66	84	90	108	114			
36	6	36	66	60	90	84	114			
	9	39	66	63	90	87	114			
12	12	42	66	66	90	90	114			
	18	48	66	72	90	96	114			
24	18	54	66	78	90	102	114			
	30	60	66	84	90	108	114			

* Reducing crosses are not available with the corrugated bottom type. Use reducer fittings (see page 14) or reducer splice plates (see page 23) in conjunction with horizontal standard cross fittings which are available with corrugated bottoms.

ITRAY HORIZONTAL REDUCING CROSS CATALOG NUMBERING EXAMPLE:

BOTTOM TYPE ← **LD - 4 A - RX 12 - 09 06** → **WIDTH 2**

VENTED	RAIL HEIGHT	FITTING CODE	RADIUS	WIDTH 1
LD - Ladder Rung				
NON-VENTED	4 - 4"	RX	12 - 12"	06 - 6"
SB - Solid Bottom	5 - 5"	MATERIAL	24 - 24"	09 - 9"
	6 - 6"		30 - 30"	12 - 12"
	7 - 7"		36 - 36"	18 - 18"
				24 - 24"
				30 - 30"
			36 - 36"	

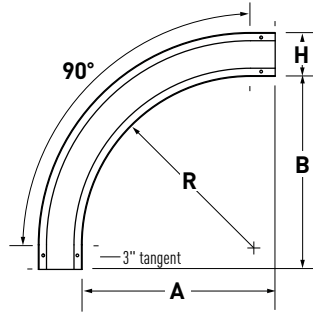

90VO
 VERTICAL OUTSIDE 90° ELBOW

A

RADIUS R	WIDTH W	RAIL HEIGHT H	A	B
12	6-36	4-7	15	15
24			27	27
36			39	39

60VO
 VERTICAL OUTSIDE 60° ELBOW

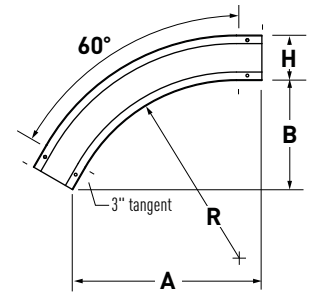
A

RADIUS R	WIDTH W	RAIL HEIGHT H	A	B
12	6-36	4-7	15	8 ⁵ / ₈
24			25 ¹ / ₄	14 ⁵ / ₈
36			35 ⁵ / ₈	20 ⁵ / ₈

45VO
 VERTICAL OUTSIDE 45° ELBOW

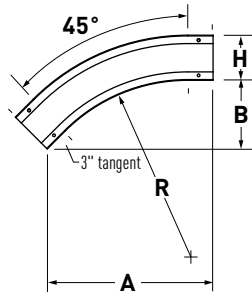
A

RADIUS R	WIDTH W	RAIL HEIGHT H	A	B
12	6-36	4-7	13 ⁵ / ₈	5 ⁵ / ₈
24			22 ¹ / ₈	9 ¹ / ₈
36			30 ⁵ / ₈	12 ⁵ / ₈

30VO
 VERTICAL OUTSIDE 30° ELBOW

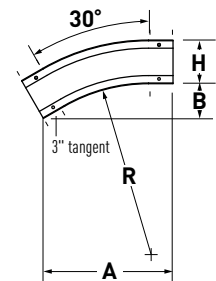
A

RADIUS R	WIDTH W	RAIL HEIGHT H	A	B
12	6-36	4-7	11 ⁵ / ₈	3 ¹ / ₈
24			17 ⁵ / ₈	4 ³ / ₄
36			23 ⁵ / ₈	6 ³ / ₈

WIDTHS (W) INCHES

6 | 9 | 12 | 18 | 24 | 30 | 36

RAIL HEIGHTS (H) INCHES

4 | 5 | 6 | 7

RADIUS (R) INCHES

12 | 24 | 36

ITRAY VERTICAL INSIDE ELBOW CATALOG NUMBERING EXAMPLE:

BOTTOM TYPE	LD - 6 A - 90VO 12 - 06	WIDTH
VENTED LD - Ladder Rung VC - Vented Corrugated NON-VENTED SC - Solid Corrugated SB - Solid Bottom	RAIL HEIGHT 4 - 4" 5 - 5" 6 - 6" 7 - 7" MATERIAL A	FITTING CODE 90VO 60VO 45VO 30VO
	RADIUS	06 - 6" 09 - 9" 12 - 12" 18 - 18" 24 - 24" 30 - 30" 36 - 36"



90VI
VERTICAL INSIDE 90° ELBOW

A

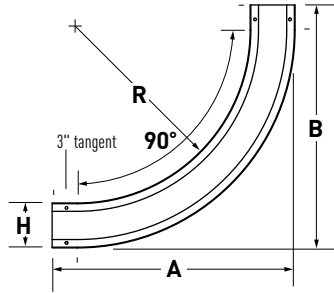

		H = 4		H = 5		H = 6		H = 7	
WIDTH W	RADIUS R	A	B	A	B	A	B	A	B
ALL	12	19	19	20	20	21	21	22	22
	24	31	31	32	32	33	33	34	34
	36	43	43	44	44	45	45	46	46

60VI
VERTICAL INSIDE 60° ELBOW

A

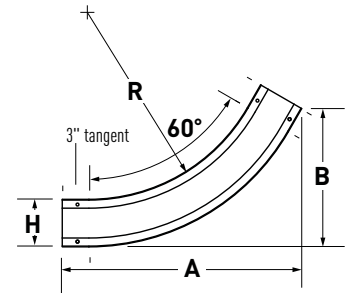

		H = 4		H = 5		H = 6		H = 7	
WIDTH W	RADIUS R	A	B	A	B	A	B	A	B
ALL	12	18 ^{3/8}	10 ^{5/8}	19 ^{1/4}	11 ^{1/8}	20 ^{1/8}	11 ^{5/8}	21	12 ^{1/8}
	24	28 ^{3/4}	16 ^{5/8}	29 ^{5/8}	17 ^{1/8}	30 ^{1/2}	17 ^{5/8}	31 ^{1/8}	18 ^{1/8}
	36	39 ^{1/8}	22 ^{5/8}	40	23 ^{1/8}	40 ^{7/8}	23 ^{5/8}	41 ^{1/4}	24 ^{1/8}

45VI
VERTICAL INSIDE 45° ELBOW

A

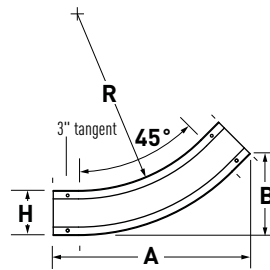

		H = 4		H = 5		H = 6		H = 7	
WIDTH W	RADIUS R	A	B	A	B	A	B	A	B
ALL	12	16 ^{3/8}	6 ^{1/4}	17 ^{1/8}	7 ^{1/8}	17 ^{7/8}	7 ^{3/8}	18 ^{1/2}	7 ^{5/8}
	24	24 ^{7/8}	10 ^{3/8}	25 ^{5/8}	10 ^{5/8}	26 ^{3/8}	10 ^{7/8}	27	11 ^{1/4}
	36	33 ^{3/8}	13 ^{7/8}	34 ^{1/8}	14 ^{1/8}	34 ^{7/8}	14 ^{3/8}	35 ^{1/2}	14 ^{3/4}

30VI
VERTICAL INSIDE 30° ELBOW

A

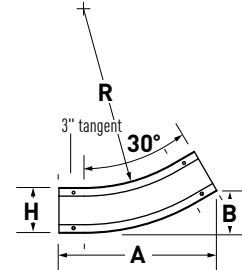

		H = 4		H = 5		H = 6		H = 7	
WIDTH W	RADIUS R	A	B	A	B	A	B	A	B
ALL	12	13 ^{5/8}	3 ^{5/8}	14 ^{1/8}	3 ^{3/4}	14 ^{5/8}	3 ^{7/8}	15 ^{1/8}	4
	24	19 ^{5/8}	5 ^{1/4}	20 ^{1/8}	5 ^{3/8}	20 ^{5/8}	5 ^{1/2}	21 ^{1/8}	5 ^{5/8}
	36	25 ^{5/8}	6 ^{7/8}	26 ^{1/8}	7	26 ^{5/8}	7 ^{1/8}	27 ^{1/8}	7 ^{1/4}

WIDTHS (W) INCHES

6 | 9 | 12 | 18 | 24 | 30 | 36

RAIL HEIGHTS (H) INCHES

4 | 5 | 6 | 7

RADIUS (R) INCHES

12 | 24 | 36

ITRAY VERTICAL INSIDE ELBOW CATALOG NUMBERING EXAMPLE:

BOTTOM TYPE ← **LD - 4 A - 90VI 12 - 09** → WIDTH

<p>VENTED</p> <p>LD - Ladder Rung</p> <p>VC - Vented Corrugated</p> <p>NON-VENTED</p> <p>SC - Solid Corrugated</p> <p>SB - Solid Bottom</p>	<p>RAIL HEIGHT</p> <p>4 - 4"</p> <p>5 - 5"</p> <p>6 - 6"</p> <p>7 - 7"</p>	<p>MATERIAL</p> <p>A</p>	<p>FITTING CODE</p> <p>90VI</p> <p>60VI</p> <p>45VI</p> <p>30VI</p>	<p>RADIUS</p> <p>12 - 12"</p> <p>24 - 24"</p> <p>36 - 36"</p>	<p>06 - 6"</p> <p>09 - 9"</p> <p>12 - 12"</p> <p>18 - 18"</p> <p>24 - 24"</p> <p>30 - 30"</p> <p>36 - 36"</p>
---	--	---------------------------------	---	---	---



TD / TU
VERTICAL TEES

A

TEE DOWN

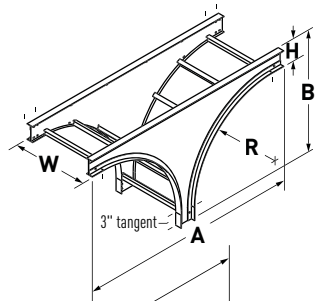

TEE UP

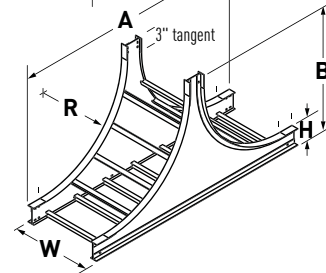
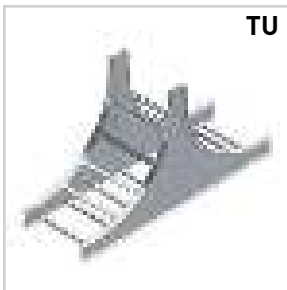

TEE UP fittings have rungs or bottom members for cable support across the bottom of the fitting.

WIDTH W	RADIUS R	RAIL HEIGHT H	A	B
ALL	24	4	58	31
		5	59	32
		6	60	33
		7	61	34

VX
VERTICAL CROSS

A

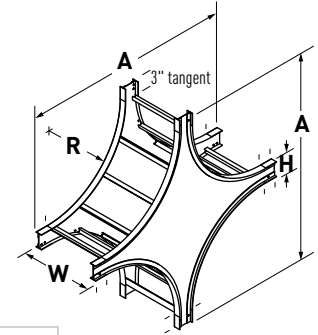

WIDTH W	RADIUS R	RAIL HEIGHT H	A
ALL	24	4	58
		5	59
		6	60
		7	61

CS
VERTICAL CABLE SUPPORT ELBOW

A

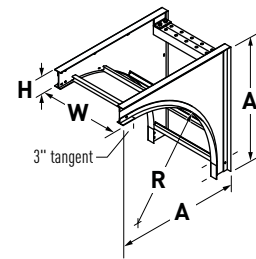

Supports cables at the top of long vertical drops where the weight of the vertical cable may be excessive. Hooks (sold separately) attach to the brace in the elbow; when used with cable grips (supplied by others), tension in the vertical cable is relieved and transferred to the elbow.

WIDTH W	RADIUS R	RAIL HEIGHT H	A
ALL	24	4	31
		5	32
		6	33
		7	34

ITRAY VERTICAL TEE CATALOG NUMBERING EXAMPLE:

BOTTOM TYPE ← **LD - 4 A - TU 24 - 09** → **WIDTH**

VENTED	RAIL HEIGHT	FITTING CODE	RADIUS	WIDTH
LD - Ladder Rung	4 - 4"	TU	24 - 24"	06 - 6"
VC - Vented Corrugated	5 - 5"	TD		09 - 9"
NON-VENTED	6 - 6"			12 - 12"
SC - Solid Corrugated	7 - 7"			18 - 18"
SB - Solid Bottom				24 - 24"
				30 - 30"
				36 - 36"

MATERIAL A



SFF / LFF / SPF
COVERS

A

SOLID FLAT FLANGED

LOUVERED FLAT FLANGED

SOLID PEAKED FLANGED

STRAIGHT SECTION COVER CATALOG NUMBERING EXAMPLE:

MATERIAL	← A - LFF - S060 - 06 →		WIDTH
A	COVER TYPE	LENGTH	06 - 6"
	SFF - Solid Flat Flanged	S060 - 60"	09 - 9"
	LFF - Louvered Flat Flanged	S072 - 72"	12 - 12"
	SPF - Solid Peaked Flanged	S120 - 120"	18 - 18"
		S144 - 144"	24 - 24"
			30 - 30"
			36 - 36"

COVER	GAGE (6"-24")	GAGE (30"-36")
SFF / LFF	0.040"	0.063"
SPF	0.040"	0.040"

FOR HORIZONTAL ELBOWS (90HB/60HB/45HB/30HB)

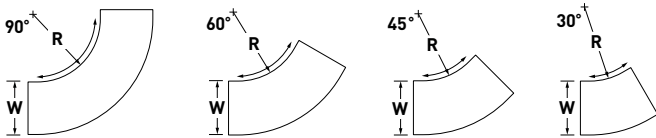

HORIZONTAL ELBOW COVER CATALOG NUMBERING EXAMPLE:

MATERIAL	← A - SFF - 90HB12 - 06 →		WIDTH
A - Aluminum for Ladder and Solid Flat Bottoms	COVER TYPE	FITTING CODE	06 - 6"
AC - Aluminum for Corrugated Bottoms	SFF - Solid Flat Flanged	90HB	09 - 9"
	LFF - Louvered Flat Flanged	60HB	12 - 12"
	SPF - Solid Peaked Flanged	45HB	18 - 18"
		30HB	24 - 24"
			30 - 30"
			36 - 36"

FOR VERTICAL OUTSIDE ELBOWS (90VO/60VO/45VO/30VO)

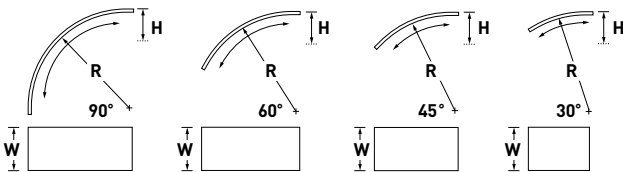

VERTICAL OUTSIDE ELBOW COVER CATALOG NUMBERING EXAMPLE:

MATERIAL	← A - SFF - 90VO24 - 12 - 4 →		WIDTH	RAIL HEIGHT
A	COVER TYPE	FITTING CODE	RADIUS	06 - 6"
	SFF - Solid Flat Flanged	90VO	12 - 12"	09 - 9"
	LFF - Louvered Flat Flanged	60VO	24 - 24"	12 - 12"
		45VO	36 - 36"	18 - 18"
		30VO		24 - 24"
				30 - 30"
				36 - 36"

FOR VERTICAL INSIDE ELBOWS (90VI/60VI/45VI/30VI)

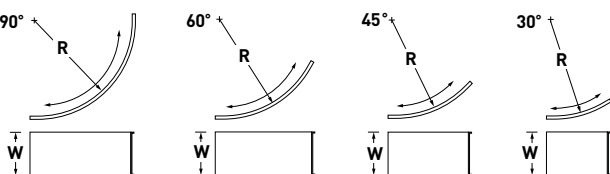

VERTICAL INSIDE ELBOW COVER CATALOG NUMBERING EXAMPLE:

MATERIAL	← A - SFF - 90VI 24 - 12 →		WIDTH
A	COVER TYPE	FITTING CODE	RADIUS
	SFF - Solid Flat Flanged	90VI	12 - 12"
	LFF - Louvered Flat Flanged	60VI	24 - 24"
		45VI	36 - 36"
		30VI	
			06 - 6"
			09 - 9"
			12 - 12"
			18 - 18"
			24 - 24"
			30 - 30"
			36 - 36"



FOR HORIZONTAL TEE (HT) AND CROSS (HX)

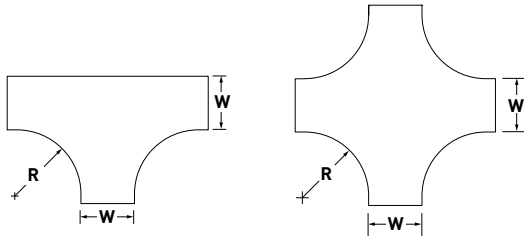

FOR HORIZONTAL REDUCING TEE (RT), EXPANDING TEE (ET) AND REDUCING CROSS (RX)

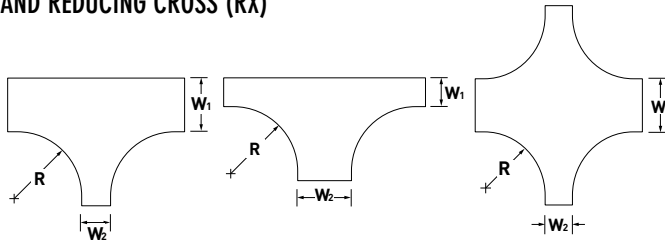

FOR HORIZONTAL STRAIGHT REDUCER (SR), LEFT HAND REDUCER (LR) AND RIGHT HAND REDUCER (RR)

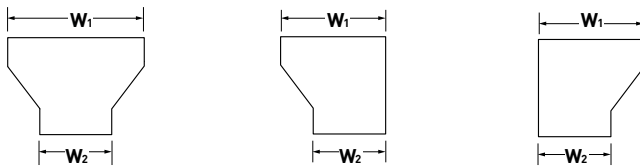

FOR HORIZONTAL LEFT HAND WYE (YL) AND RIGHT HAND WYE (YR)

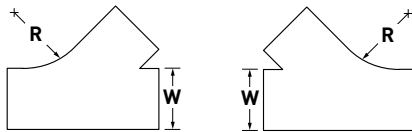

MAIN WIDTHS (W1)	AVAILABLE REDUCING BRANCH WIDTHS (W2)					
9	6	-	-	-	-	-
12	6	9	-	-	-	-
18	6	9	12	-	-	-
24	6	9	12	18	-	-
30	6	9	12	18	24	-
36	6	9	12	18	24	30

HORIZONTAL TEE COVER CATALOG NUMBERING EXAMPLE:

MATERIAL ← **A - SFF - HT 12 - 06** → WIDTH

A → COVER TYPE

SFF – Solid Flat Flanged
LFF – Louvered Flat Flanged
SPF – Solid Peaked Flanged

HT → FITTING CODE
HX → FITTING CODE

12 → RADIUS
24 – 24"
36 – 36"

06 – 6"
09 – 9"
12 – 12"
18 – 18"
24 – 24"
30 – 30"
36 – 36"

HORIZONTAL REDUCING TEE COVER CATALOG NUMBERING EXAMPLE:

MATERIAL ← **A - SFF - RT 12 - 1206** → W1 W2*

A → COVER TYPE

SFF – Solid Flat Flanged
LFF – Louvered Flat Flanged
SPF – Solid Peaked Flanged

RT → FITTING CODE
ET → FITTING CODE
RX → FITTING CODE

12 → RADIUS
24 – 24"
36 – 36"

06 – 6"
09 – 9"
12 – 12"
18 – 18"
24 – 24"
30 – 30"
36 – 36"

06 – 6"
09 – 9"
12 – 12"
18 – 18"
24 – 24"
30 – 30"
36 – 36"

* See tables below for available branch widths.

HORIZONTAL STRAIGHT REDUCER COVER CATALOG NUMBERING EXAMPLE:

MATERIAL ← **A - SFF - SR - 1206** → W1 W2*

A → COVER TYPE

SFF – Solid Flat Flanged
LFF – Louvered Flat Flanged
SPF – Solid Peaked Flanged

SR → FITTING CODE
LR → FITTING CODE
RR → FITTING CODE

12 → RADIUS
24 – 24"
30 – 30"
36 – 36"

06 – 6"
09 – 9"
12 – 12"
18 – 18"
24 – 24"
30 – 30"
36 – 36"

06 – 6"
09 – 9"
12 – 12"
18 – 18"
24 – 24"
30 – 30"
36 – 36"

* See tables below for available branch widths.

HORIZONTAL LEFT HAND WYE COVER CATALOG NUMBERING EXAMPLE:

MATERIAL ← **A - SFF - YL 24 - 12** → WIDTH

A → COVER TYPE

SFF – Solid Flat Flanged
LFF – Louvered Flat Flanged
SPF – Solid Peaked Flanged

YL → FITTING CODE
YR → FITTING CODE

24 → RADIUS

06 – 6"
09 – 9"
12 – 12"
18 – 18"
24 – 24"
30 – 30"
36 – 36"

MAIN WIDTHS (W1)	AVAILABLE EXPANDING BRANCH WIDTHS (W2)					
6	9	12	18	24	30	36
9	12	18	24	30	36	-
12	18	24	30	36	-	-
18	24	30	36	-	-	-
24	30	36	-	-	-	-
30	36	-	-	-	-	-

FCC / PCC / PCT COVER CONNECTORS

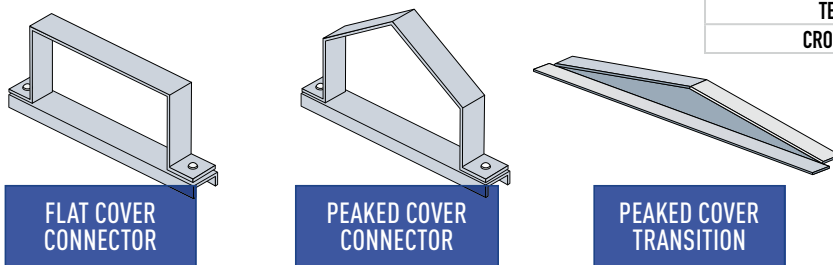

QUANTITY OF COVER CLAMPS REQUIRED

STRAIGHT SECTION – 5' & 6'	2
STRAIGHT SECTION – 10' & 12'	3
HORIZONTAL/VERTICAL ELBOWS	2
TEES	3
CROSSES	4

PRODUCT CODE	FASTENER OPTIONS
FCC	GE S6
PCC	S6

CATALOG NUMBERING EXAMPLE:

H / Material Width Fasteners
4 A - **FCC** - 06 - GE

CATALOG NUMBERING EXAMPLE:

Material Width Fasteners
A - **PCT** - 06 - S6



SSP
STRAIGHT SPLICE KIT

A



PRODUCT CODE	FASTENER OPTIONS
SSP	GE S6
CATALOG NUMBERING EXAMPLE:	
H / Material	Fasteners
4 A -	SSP - S 6

- 12" length
- Designed for splicing Itray straight sections
- Includes splices and tray connection hardware
- Patented design

FSP
FITTING SPLICE KIT

A



PRODUCT CODE	FASTENER OPTIONS
FSP	GE S6
CATALOG NUMBERING EXAMPLE:	
H / Material	Fasteners
4 A -	FSP - G E

- 6" length
- Designed for splicing Itray fittings
- Includes splices and tray connection hardware
- Patented design

USP
UNIVERSAL SPLICE KIT

A



PRODUCT CODE	FASTENER OPTIONS
USP	GE S6
CATALOG NUMBERING EXAMPLE:	
H / Material	Fasteners
4 A -	USP - G E

- Designed to transition to PW C-channel and other I-beam systems
- Includes splices and tray connection hardware

USPB
UNIVERSAL BLANK SPLICE KIT

A



PRODUCT CODE	FASTENER OPTIONS
USPB	GE S6
CATALOG NUMBERING EXAMPLE:	
H / Material	Fasteners
4 A -	USPB - S 6

- Field drill for connection to trays from other manufacturers
- Includes splices and tray connection hardware

EXSP
EXPANSION SPLICE KIT

A

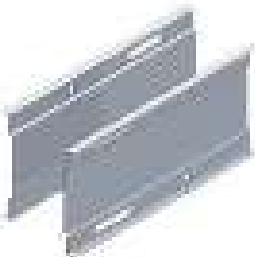

PRODUCT CODE	FASTENER OPTIONS
EXSP	GE S6
CATALOG NUMBERING EXAMPLE:	
H / Material	Fasteners
4 A -	EXSP - S 6

- Install as required P.xx or NEMA VE-2 (see p. 61)
- Includes splices and tray connection hardware
- Patented design

VHSP
VERTICAL HANGER SPLICE KIT

A



PRODUCT CODE	FASTENER OPTIONS
VHSP	GE S6
CATALOG NUMBERING EXAMPLE:	
H / Material	Fasteners
4 A -	VHSP - G E

- For vertical tray support with threaded rods
- Includes splices and tray connection hardware

WIDTHS (W) INCHES
6 | 9 | 12 | 18 | 24 | 30 | 36

RAIL HEIGHTS (H) INCHES
4 | 5 | 6 | 7

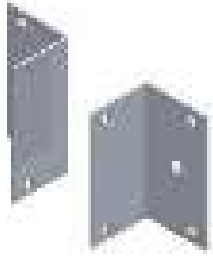

90SP 90° CONNECTOR SPLICE KIT

A

PRODUCT CODE	FASTENER OPTIONS
90SP	GE S6
CATALOG NUMBERING EXAMPLE:	
Rail Height / Material	Fasteners
4 A - 90SP - G E	

- Includes 8 splice bolts for connecting trays

FFSP FLOOR FLANGE SPLICE KIT

A

PRODUCT CODE	FASTENER OPTIONS
FFSP	GE S6
CATALOG NUMBERING EXAMPLE:	
Rail Height / Material	Fasteners
4 A - FFSP - S 6	

- Includes splices and tray connection hardware

HASP HORIZONTAL ADJUSTABLE SPLICE KIT

A

PRODUCT CODE	FASTENER OPTIONS
HASP	GE S6
CATALOG NUMBERING EXAMPLE:	
Rail Height / Material	Fasteners
4 A - HASP - S 6	

- Field drill outer splices
- Includes splices and tray connection hardware



VASP VERTICAL ADJUSTABLE SPLICE KIT

A

PRODUCT CODE	FASTENER OPTIONS
VASP	GE S6
CATALOG NUMBERING EXAMPLE:	
H / Material	Fasteners
4 A - VASP - G E	

- Includes splices and tray connection hardware

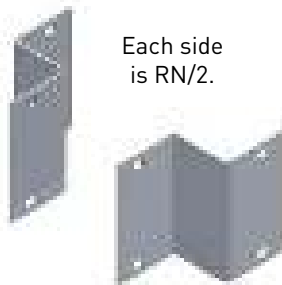

SRSP STRAIGHT REDUCER SPLICE KIT

A

PRODUCT CODE	FASTENER OPTIONS
SRSP	GE S6
CATALOG NUMBERING EXAMPLE:	
H / Material	RN Fasteners
4 A - SRSP - 0 6 - G E	

- Includes splices and tray connection hardware

ORSP OFFSET REDUCER SPLICE KIT

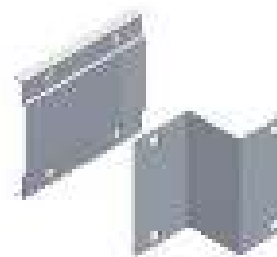
A

PRODUCT CODE	FASTENER OPTIONS
ORSP	GE S6
CATALOG NUMBERING EXAMPLE:	
H / Material	RN Fasteners
4 A - ORSP - 0 6 - S 6	

- Includes splices and tray connection hardware
- Patented design

TRAY WIDTH REDUCTION (RN) INCHES

3 | 6 | 9 | 12 | 15 | 18 | 21 | 24 | 27

Bonding jumpers are required.



RHSP
REDUCING HEIGHT SPLICE KIT

A



- Includes splices and tray connection hardware

PRODUCT CODE	FASTENER OPTIONS
RHSP	GE S6
CATALOG NUMBERING EXAMPLE:	
H1 / H2 / Material	Fasteners
5 4 A - RHSP	- GE

H1	H2 OPTIONS		
5	4	-	-
6	4	5	-
7	4	5	6

TBC
TRAY-TO-BOX CONNECTOR (FRAME TYPE)

A

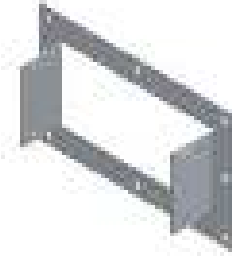

PRODUCT CODE	FASTENER OPTIONS
TBC	GE S6
CATALOG NUMBERING EXAMPLE:	
H / Material	RN Fasteners
4 A - TBC	- 06 - S6

- Includes one frame and connection hardware
- Designed to support Itray at connection to electrical enclosures

BE
BLIND END KIT

A



PRODUCT CODE	FASTENER OPTIONS
BE	GE S6
CATALOG NUMBERING EXAMPLE:	
H / Material	W Fasteners
4 A - BE	- 06 - S6

- Includes one frame and connection hardware

DO
DROP OUT KIT

A



PRODUCT CODE	FASTENER OPTIONS
DO	S6
CATALOG NUMBERING EXAMPLE:	
Material	W Fasteners
A - DO	- 06 - S6

- Snaps in place over I-rung

DIV
VERTICAL ELBOW DIVIDERS

A



PRODUCT CODE	FASTENER OPTIONS
DIV	ZN S6
CATALOG NUMBERING EXAMPLE:	
H / Material	Elbow R Fasteners
6 A - DIV	- 90V0 - 24 - S6

- Each divider includes two self-drilling screws

RADIUS (R) INCHES

12	24	36
----	----	----

WIDTHS (W) INCHES

6	9	12	18	24	30	36
---	---	----	----	----	----	----

RAIL HEIGHTS (H) INCHES

4	5	6	7
---	---	---	---

IP34
CABLE TRAY ISOLATION PAD



PRODUCT CODE	WIDTH	LENGTH (FOLDED)
IP34	2.75	4

- Reduces vibration from industrial machinery
- Use an electrical isolation barrier or as a barrier between dissimilar metals
- High-visibility red color is useful during inspections
- Made from durable HDPE (High-Density Polyethylene)
- Use with a hold-down clamp or as configured for an expansion guide

OHC B OVERHEAD CLAMP KIT

A

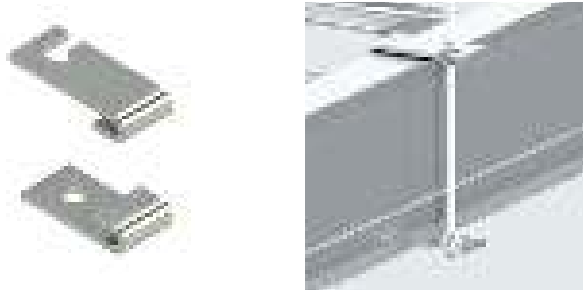

- Designed for trapeze hanging of ITray without drilling.
- Mounting kits available for 3/8" and 1/2" threaded rod
- Kit includes: eight SFHN (nuts with washers), two top brackets, two bottom brackets. Threaded rod sold separately.
- Load rated at 1220 lbs/pair
- Can be used on fittings or straight sections of PW ITray

PRODUCT CODE	HOLE SIZE	WIDTH	LENGTH (TOP)	LENGTH (BOTTOM)	FASTENERS
OHC B38KIT	.375	1.5	3.6	3	GE
OHC B12KIT	.5	1.5	3.6	3	

OCK OUTDOOR CONVERSION KIT

A

Makes ladder tray wall penetrations weather resistant to minimize water intrusions. Removable cover/shield fastens to tray and wall penetration sleeve for the utmost in weather protection.



PRODUCT CODE	FASTENER OPTIONS
OCK	GE S6
CATALOG NUMBERING EXAMPLE:	
H / Material	W Fasteners
4 A - OCK	- 06 - S6

- Wall Penetration Sleeve (WPS or FWPS) not included in kit, must be ordered separately

FWPS FIRE WALL PENETRATION SLEEVE

M G

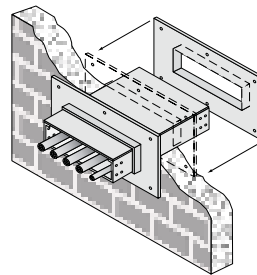

PRODUCT CODE	FASTENER OPTIONS
FWPS	GE S6
CATALOG NUMBERING EXAMPLE:	
H / Material	W Fasteners
4 G - FWPS	- 06 - S6

- Steel only; aluminum not available as it does not meet fire rating requirements
- See pgs. B.58-59 for more information

WPS WALL PENETRATION SLEEVE

M G

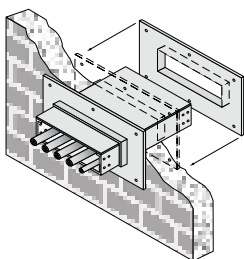

Provides a rigid support for cable tray at wall penetrations. Overall length of the sleeve is 20". Will fit walls up to 8" thick. Bonding jumpers are not required for use with wall sleeves. Two pairs of splice plates and fasteners are included for tray attachment.

PRODUCT CODE	FASTENER OPTIONS
WPS	GE S6
CATALOG NUMBERING EXAMPLE:	
H / Material	W Fasteners
4 M - WPS	- 06 - S6

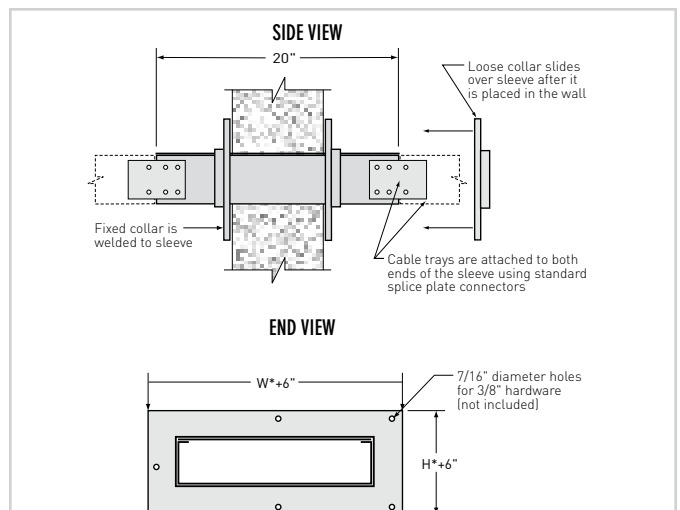

Each cable tray firestop sleeve includes:

- One penetration sleeve with flanges
- Hilti Fire Blocks
- One Hilti Firestop Putty Stick
- Hardware for cable tray connection to the wall sleeve

UL classified for use with:
 2-hr concrete or block walls
 2-hr concrete floors
 1-hr gypsum walls
 2-hr gypsum walls



LONG-SPAN

Trays for extremely heavy loads and long spans have I-beam side rails and are available in lengths up to 50'.

A	ALUMINUM
G	HOT-DIP GALVANIZED STEEL

WIDTHS (W) INCHES

12 | 18 | 24 | 30 | 36

RAIL HEIGHTS (H) INCHES

8 | 10

LENGTHS (L) FEET

30 | 40 | 50

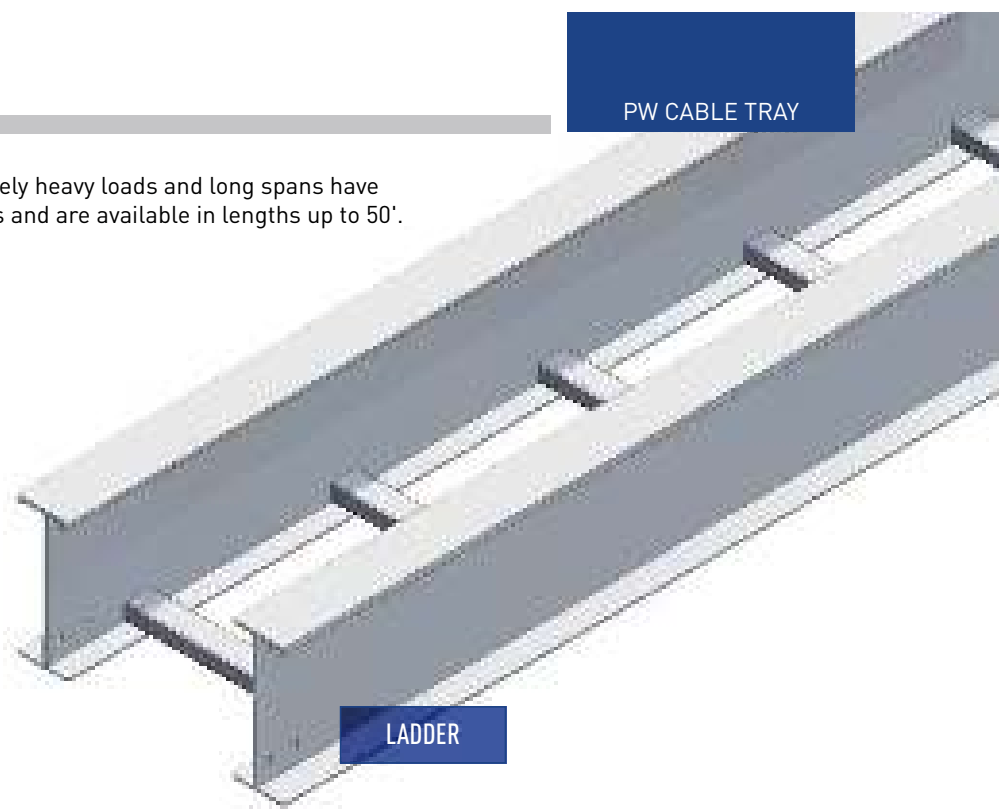

CONNECTORS:

Necessary connectors and fasteners are supplied with all tray. Extra connectors for field cuts or spares must be ordered separately.

SAFE LOAD:

Allowable cable load in pounds per linear foot uniformly distributed. Based on tray with standard rung on 9" centers and supported on simple beam with safety factor of 1.5 per NEMA VE1.

CONCENTRATED LOAD:

All ladders will support a 200 lb. concentrated load applied at the center of the tray in addition to the NEMA-rated cable load without collapse.

RAIL HEIGHT (IN.)	LOAD DEPTH (IN.)	RAIL FLANGE (IN.)	NEMA CLASS	CSA CLASS	SERIES	TRAY SYSTEM NUMBER	AMP RATING
8	6*	3	20C+	E, 6M	S2		
	6*	2½			S2	4823	2000
10	6*	4			S2	4904	2000

RAIL HEIGHT (IN.)	LOAD DEPTH (IN.)	RAIL FLANGE (IN.)	NEMA CLASS	CSA CLASS	SERIES	TRAY SYSTEM NUMBER	AMP RATING
8	6*	2¼	20C+	-	S2		
		4			S2	1952	600
10	5	4			S2	1953	600
					S2	1954†	600

* 6" load depth is the maximum permissible by NEC; † Fittings not available





Legrand trays marked with CSA load class have been tested (loading, finish and electrical) by UL to CSA standard 126 22.2 .



All Legrand aluminum and steel cable trays are Classified by UL as equipment grounding conductors per NEC 392.60. [UL File No. E60796]

		SUPPORT SPAN (FT.)																	
		20	22	24	26	28	30	34	36	40									
		SAFE LOAD DATA (LBS./FT.) / DEFLECTION (IN.) / SAFETY FACTOR 1.5																	
270	1.88	218	2.22	179	2.58	150	2.98	127	3.39	108	3.81	76	4.44	64	4.70	48	5.31		
292	2.00	236	2.37	194	2.75	162	3.17	137	3.60	117	4.05	82	4.69	69	4.97	52	5.70		
400	1.15	331	1.39	278	1.66	237	1.94	204	2.25	178	2.59	138	3.32	123	3.73	100	4.60		

		SUPPORT SPAN (FT.)																									
		20	22	24	26	28	30	32	34	36	38	40	45	50													
		SAFE LOAD DATA (LBS./FT.) / DEFLECTION (IN.) / SAFETY FACTOR 1.5																									
203	0.88	167	1.06	141	1.27	120	1.49	103	1.72	90	1.98	81	2.22	68	2.47	60	2.72	54	3.06	48	3.31						
360	0.98	298	1.18	250	1.41	213	1.65	184	1.92	160	2.20	139	2.47	121	2.74	107	3.05	95	3.35	85	3.69	66	4.00	51	5.37		
900	1.04	744	1.26	625	1.50	533	1.77	459	2.05	400	2.35	347	2.64	304	2.95	268	3.26	238	3.60	212	3.94	164	4.87	124	5.62		

LONG-SPAN STRAIGHT SECTION CATALOG NUMBERING EXAMPLE:

BOTTOM TYPE ← **09-4823-0030-36** → WIDTH
 12 - 12"
 18 - 18"
 24 - 24"
 30 - 30"
 36 - 36"

VENTED
 09 - 9" Rung Spacing*
 12 - 12" Rung Spacing*
 18 - 18" Rung Spacing*
 * Standard rung spacing

TRAY SYSTEM NUMBER
 This identifies the specific tray design and is used as a product number prefix for straight sections.

LENGTH**
 0030 - 30'-0"
 0040 - 40'-0"
 0050 - 50'-0"

** For spans shorter than 30' use 7A24C series. See page B.10.



STEEL

G HOT-DIP GALVANIZED STEEL

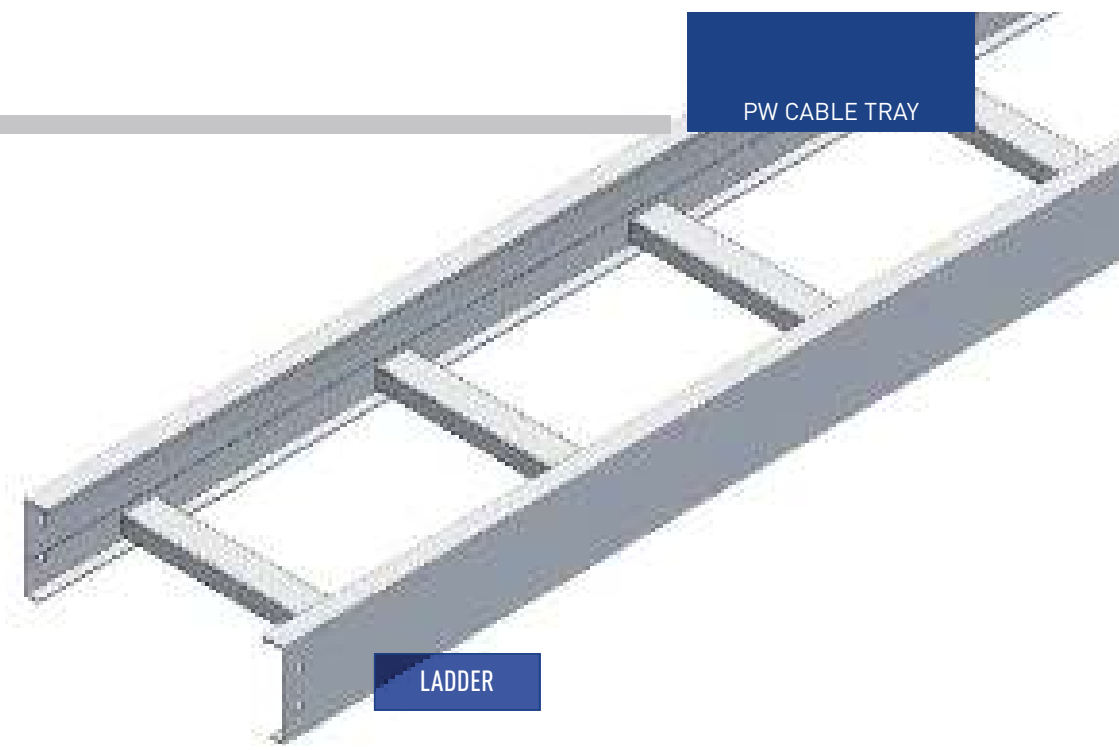

WIDTHS (W) INCHES

6 | 9 | 12 | 18 | 24 | 30 | 36

RAIL HEIGHTS (H) INCHES

4 | 5 | 6 | 7

LENGTHS (L) FEET

10 | 12 | 20 | 24

CONNECTORS & FITTINGS:

Necessary connectors and fasteners are supplied with all trays and fittings. Extra connectors for field cuts or spares must be ordered separately.

SAFE LOAD:

Allowable cable load in pounds per linear foot uniformly distributed. Based on tray with standard rung on 9" centers and supported on simple beam with safety factor of 1.5 per NEMA VE1.

CONCENTRATED LOAD:

All ladders with solid rungs and trays with corrugated bottoms will support a 200 lb. concentrated load applied at the center of the tray in addition to the NEMA-rated cable load without collapse.

RAIL HEIGHT (IN.)	LOAD DEPTH (IN.)	RAIL FLANGE (IN.)	NEMA CLASS	CSA CLASS	SERIES	TRAY SYSTEM NUMBER		AMP RATING
4	3	1	12C, 16A	D, 3M	S1	A457	-	100
			20A, 16B	-	S2	1D80	1D81	200
		1 3/4	20B, 16C	D, 6M	S2	1D82	1D83	400
			20C	E, 6M	S2	1D69*	1D70	400
5	4	1	12C, 16A	D, 3M	S1	1E72	-	100
			20B, 16C	-	S2	1E45	1E46	400
		1 3/4	20C	D, 6M	S2	1E53*	1E54	400
6	5	1	12C, 16A	D, 3M	S1	A639	-	100
			20B, 16C	E, 6M	S2	1F45*	1F46	400
		1 3/4	20C	E, 6M	S2	1F53*	1F54	400
7	6	1	12C, 16A	D, 3M	S1	1772	-	100
			20B, 16C	E, 6M	S2	1755*	1756	400
		1 3/4	20C	E, 6M	S2	1753	1754	400

*1D69, 1F45, and 1F53 corrugated bottom tray systems have a CSA load class D,6M rating. 1E53 and 1755 corrugated bottom tray systems do not have CSA load class ratings.

SPLICES Match above to determine the connectors you need.



SERIES1

Fitting side rails have 2" tangents (flat portion beyond curvature) at the end of each fitting, to accommodate splice plates with four holes.

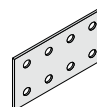

SERIES2

Fitting side rails have 5" tangents at the end of each fitting, to accommodate splice plates with eight holes.





	SUPPORT SPAN (FT.)																			
	6	8	10	12	14	16	18	20	22	24										
	SAFE LOAD DATA (LBS./FT.) / DEFLECTION (IN.) / SAFETY FACTOR 1.5																			
439	0.31	250	0.55	160	0.86	111	1.24	78	1.61	58	2.06									
439	0.20	338	0.51	216	0.79	150	1.14	110	1.55	84	2.02	67	2.56	54	3.16	44	3.74	34	4.07	
439	0.16	439	0.50	312	0.88	217	1.26	159	1.72	122	2.25	96	2.84	78	3.51	63	4.18	52	4.87	
		439	0.39	400	0.87	278	1.25	204	1.70	156	2.21	123	2.80	100	3.46	81	4.09	66	4.77	
400	0.21	225	0.38	144	0.59	100	0.85	71	1.13	52	1.40									
439	0.11	439	0.37	304	0.62	211	0.90	155	1.22	119	1.59	94	2.02	76	2.49	61	2.92	50	3.38	
		439	0.34	400	0.75	278	1.08	204	1.47	156	1.92	123	2.43	100	3.00	81	3.54	60	4.13	
420	0.13	236	0.22	151	0.35	105	0.50	74	0.65	55	0.83									
439	0.08	439	0.25	336	0.47	233	0.68	171	0.92	131	1.20	104	1.52	84	1.88	68	2.24	53	2.47	
		439	0.20	439	0.50	319	0.75	235	1.02	180	1.34	142	1.69	115	2.09	93	2.48	73	2.75	
400	0.10	225	0.18	144	0.28	100	0.40	71	0.53	52	0.66									
439	0.07	439	0.22	300	0.38	208	0.54	153	0.73	117	0.96	93	1.22	75	1.50	61	1.79	50	2.08	
		439	.017	439	0.42	319	0.63	235	0.86	180	1.12	142	1.42	115	1.75	93	2.11	76	2.52	



Legrand trays marked with CSA load class have been tested (loading, finish and electrical) by UL to CSA standard 126 22.2 .



All Legrand steel cable trays are Classified by UL as equipment grounding conductors per NEC 392.60. (UL File No. E60796)

METALLIC STRAIGHT SECTIONS - STEEL

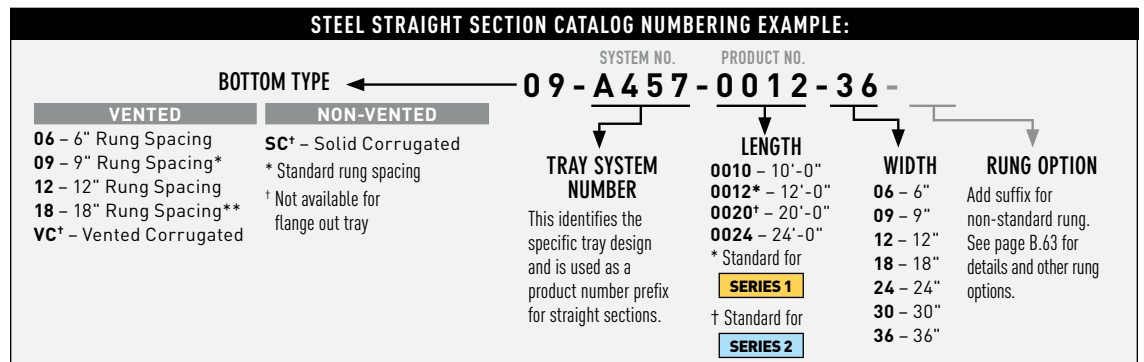

STAINLESS STEEL

L	STAINLESS STEEL AISI Type 304L
T	STAINLESS STEEL AISI Type 316L

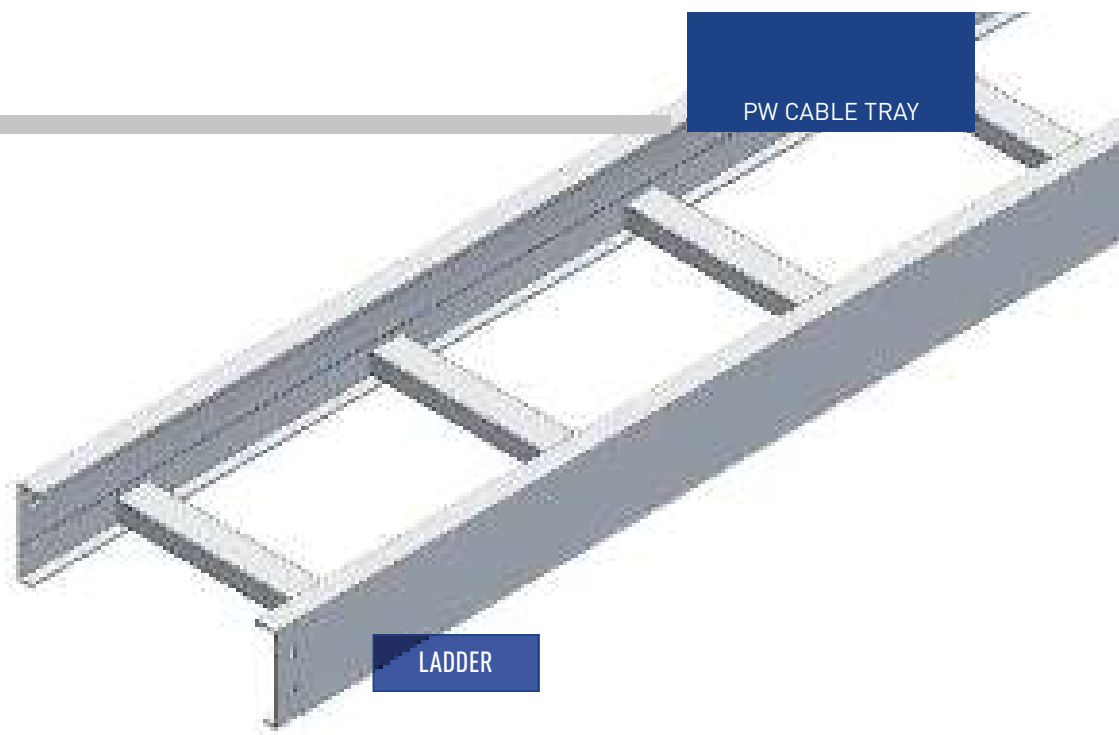

WIDTHS (W) INCHES

6 | 9 | 12 | 18 | 24 | 30 | 36

RAIL HEIGHTS (H) INCHES

4 | 5 | 6 | 7

LENGTHS (L) FEET

10 | 12 | 20 | 24

CONNECTORS & FITTINGS:





Necessary connectors and fasteners are supplied with all trays and fittings. Extra connectors for field cuts or spares must be ordered separately.

SAFE LOAD:

Allowable cable load in pounds per linear foot uniformly distributed. Based on tray with standard rung on 9" centers and supported on simple beam with safety factor of 1.5 per NEMA VE1.

CONCENTRATED LOAD:

All ladders with solid rungs and trays with corrugated bottoms will support a 200 lb. concentrated load applied at the center of the tray in addition to the NEMA-rated cable load without collapse.

RAIL HEIGHT (IN.)	LOAD DEPTH (IN.)	RAIL FLANGE (IN.)	NEMA CLASS	SERIES	TRAY SYSTEM NUMBER			
								
4	3	1	12B	S1	3408	3416	-	-
			12C, 16A	S1	3409	3417	-	-
		1 3/4	20A, 16B	S2	3476	3D85	3D63	3D82
			20B, 16C	S2	3456	3D92	3D93	3D58
		20C	S2	3406	3445	3407	3446	
5	4	1	12B	S1	3504	3514	-	-
			12C, 16A	S1	3505	3515	-	-
		1 3/4	20B, 16C	S2	3551	3594	3550	3582
			20C	S2	3587	3593	3592	3583
6	5	1	12B	S1	3603	3620	-	-
			12C, 16A	S1	3604	3621	-	-
		1 3/4	20B, 16C	S2	3F67	3F85	3F68	3F66
			20C	S2	3645	3F35	3F58	3F61
7	6	1	12B	S1	3734	3738	-	-
			12C, 16A	S1	3735	3739	-	-
		1 3/4	20B, 16C	S2	3701	3723	3754	3756
			20C	S2	3714	3724	3722	3760

SPLICES Match above to determine the connectors you need.



SERIES1

Fitting side rails have 2" tangents (flat portion beyond curvature) at the end of each fitting, to accommodate splice plates with four holes.

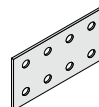

SERIES2

Fitting side rails have 5" tangents at the end of each fitting, to accommodate splice plates with eight holes.





	SUPPORT SPAN (FT.)																			
	6	8	10	12	14	16	18	20	22	24										
	SAFE LOAD DATA (LBS./FT.) / DEFLECTION (IN.) / SAFETY FACTOR 1.5																			
300	0.30	169	0.54	108	0.85	75	1.22													
400	0.32	225	0.57	144	0.90	100	1.29	71	1.71	52	2.13									
556	0.31	313	0.55	200	0.86	139	1.24	102	1.69	78	2.20	62	2.79	50	3.44					
564	0.24	469	0.62	300	0.97	208	1.39	153	1.89	117	2.47	93	3.13	75	3.70	86	4.60	48	5.13	
		564	0.54	400	0.94	278	1.36	204	1.85	156	2.41	123	3.05	100	3.77	81	4.45	63	4.96	
300	0.20	169	0.35	108	0.55	75	0.79													
400	0.23	225	0.41	144	0.64	100	0.93	71	1.23	52	1.53									
564	0.16	469	0.42	300	0.66	208	0.95	153	1.29	117	1.69	93	2.14	75	2.64	61	3.14	48	3.51	
		564	0.46	400	0.80	278	1.16	204	1.57	156	2.05	123	2.60	100	3.21	81	3.79	63	4.22	
300	0.11	169	0.20	108	0.31	75	0.45													
400	0.14	225	0.24	144	0.38	100	0.54	71	0.71	52	0.89									
564	0.12	469	0.32	300	0.51	208	0.73	153	0.99	117	1.30	93	1.64	75	2.03	61	2.42	48	2.70	
		564	0.31	400	0.54	278	0.77	204	1.05	156	1.38	123	1.74	100	2.15	81	2.54	63	2.83	
300	0.10	169	0.17	108	0.27	75	0.39													
400	0.11	225	0.19	144	0.30	100	0.43	71	0.57	52	0.71									
564	0.10	469	0.26	300	0.41	208	0.58	153	0.79	117	1.04	93	1.31	75	1.62	61	1.93	48	2.15	
		564	0.28	400	0.48	278	0.69	204	0.93	156	1.22	123	1.55	100	1.91	81	2.05	63	2.28	

STAINLESS STEEL STRAIGHT SECTION CATALOG NUMBERING EXAMPLE:

BOTTOM TYPE ← 09 - 3620 - 0012 - 18 -

VENTED

06 - 6" Rung Spacing
 09 - 9" Rung Spacing*
 12 - 12" Rung Spacing
 18 - 18" Rung Spacing

NON-VENTED

SF* - Solid Flat Bottom
 * Standard rung spacing
 † Not available with flange out tray

TRAY SYSTEM NUMBER

This identifies the specific tray design and is used as a product number prefix for straight sections.

LENGTH

0010 - 10'-0"
 0012* - 12'-0"
 0020† - 20'-0"
 0024 - 24'-0"
 * Standard for **SERIES 1**
 † Standard for **SERIES 2**

WIDTH

06 - 6"
 09 - 9"
 12 - 12"
 18 - 18"
 24 - 24"
 30 - 30"
 36 - 36"

RUNG OPTION

Add suffix for non-standard rung. See page B.63 for details and other rung options.



HORIZONTAL 90° ELBOW

G L T

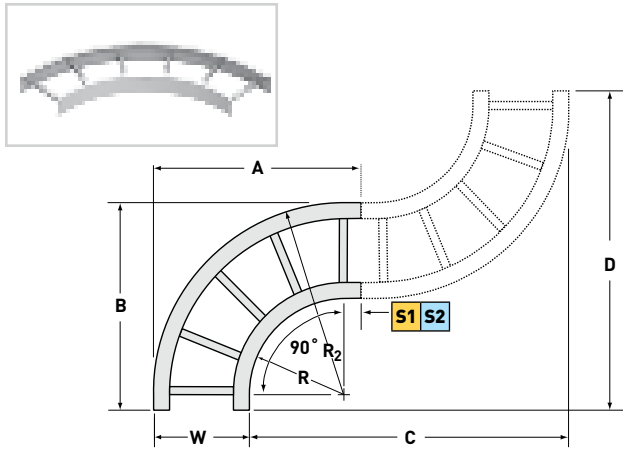

HORIZONTAL 60° ELBOW

G L T

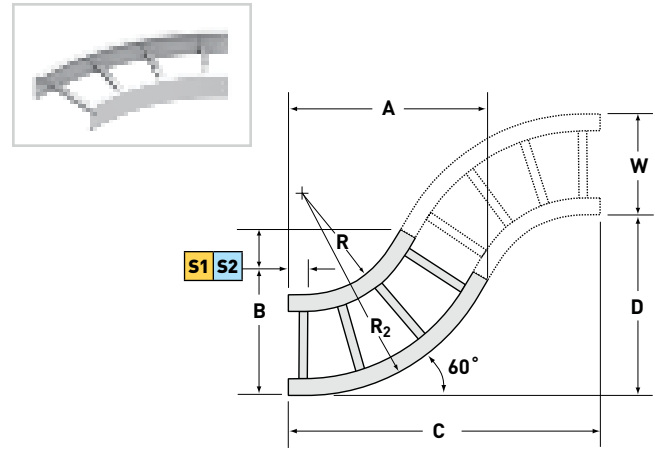

PRODUCT NUMBER RADIUS (IN.)	W	R2	SERIES1				SERIES2			
			A	B	C	D	A	B	C	D
9012 12"	6	18	20	20	34	34	23	23	40	40
	9	21	23	23	37	37	26	26	43	43
	12	24	26	26	40	40	29	29	46	46
	18	30	32	32	46	46	35	35	52	52
	24	36	38	38	52	52	41	41	58	58
	30	42	44	44	58	58	47	47	64	64
9024 24"	6	30	32	32	58	58	35	35	64	64
	9	33	35	35	61	61	38	38	67	67
	12	36	38	38	64	64	41	41	70	70
	18	42	44	44	70	70	47	47	76	76
	24	48	50	50	76	76	53	53	82	82
	30	54	56	56	82	82	59	59	88	88
9036 36"	6	42	44	44	82	82	47	47	88	88
	9	45	47	47	85	85	50	50	91	91
	12	48	50	50	88	88	53	53	94	94
	18	54	56	56	94	94	59	59	100	100
	24	60	62	62	100	100	65	65	106	106
	30	66	68	68	106	106	71	71	112	112
36	72	74	74	112	112	77	77	118	118	

PRODUCT NUMBER RADIUS (IN.)	W	R2	SERIES1				SERIES2			
			A	B	C	D	A	B	C	D
6012 12"	6	18	18 ⁵ / ₈	13 ³ / ₄	32	18 ¹ / ₂	23 ³ / ₈	16 ³ / ₈	41	23 ³ / ₄
	9	21	21 ¹ / ₄	16 ³ / ₄	34 ⁵ / ₈	20	25 ⁵ / ₈	19 ³ / ₈	43 ¹ / ₂	25 ¹ / ₄
	12	24	23 ³ / ₄	19 ³ / ₄	37 ¹ / ₈	21 ¹ / ₂	28 ³ / ₈	22 ³ / ₈	46 ¹ / ₄	26 ³ / ₄
	18	30	29	25 ³ / ₄	42 ³ / ₈	24 ¹ / ₂	33 ¹ / ₂	28 ³ / ₈	51 ³ / ₈	29 ³ / ₄
	24	36	34 ¹ / ₈	31 ³ / ₄	47 ¹ / ₂	27 ¹ / ₂	38 ⁵ / ₈	34 ³ / ₈	56 ¹ / ₂	32 ³ / ₄
	30	42	39 ³ / ₈	37 ³ / ₄	52 ³ / ₄	30 ¹ / ₂	43 ³ / ₈	40 ³ / ₈	61 ³ / ₄	35 ³ / ₄
6024 24"	6	30	29	19 ³ / ₄	52 ³ / ₄	30 ¹ / ₂	33 ¹ / ₂	22 ³ / ₈	61 ³ / ₄	35 ³ / ₄
	9	33	31 ⁵ / ₈	22 ³ / ₄	55 ³ / ₈	32	36 ¹ / ₈	25 ³ / ₈	64 ³ / ₈	37 ¹ / ₄
	12	36	34 ¹ / ₈	25 ³ / ₄	57 ⁷ / ₈	33 ¹ / ₂	38 ³ / ₄	28 ³ / ₈	67	38 ³ / ₄
	18	42	39 ³ / ₈	31 ³ / ₄	63 ¹ / ₈	36 ¹ / ₂	43 ³ / ₈	34 ³ / ₈	72 ¹ / ₈	41 ³ / ₄
	24	48	44 ¹ / ₂	37 ³ / ₄	68 ¹ / ₄	39 ¹ / ₂	49 ¹ / ₈	40 ³ / ₈	77 ³ / ₈	44 ³ / ₄
	30	54	49 ³ / ₄	43 ³ / ₄	73 ¹ / ₂	42 ¹ / ₂	54 ¹ / ₈	46 ³ / ₈	82 ⁵ / ₈	47 ³ / ₄
6036 36"	6	42	39 ³ / ₈	25 ³ / ₄	73 ¹ / ₂	42 ¹ / ₂	43 ³ / ₈	28 ³ / ₈	82 ¹ / ₂	47 ³ / ₄
	9	45	42	28 ³ / ₄	76 ¹ / ₈	44	46 ¹ / ₂	31 ³ / ₈	85 ¹ / ₈	49 ¹ / ₄
	12	48	44 ¹ / ₂	31 ³ / ₄	78 ⁵ / ₈	45 ¹ / ₂	49 ¹ / ₈	34 ³ / ₈	87 ³ / ₄	50 ³ / ₄
	18	54	49 ³ / ₄	37 ³ / ₄	83 ⁷ / ₈	48 ¹ / ₂	54 ¹ / ₄	40 ³ / ₈	92 ⁷ / ₈	53 ³ / ₄
	24	60	54 ⁷ / ₈	43 ³ / ₄	89	51 ¹ / ₂	59 ¹ / ₂	46 ³ / ₈	98 ¹ / ₈	56 ³ / ₄
	30	66	60 ¹ / ₈	49 ³ / ₄	94 ¹ / ₄	54 ¹ / ₂	64 ³ / ₄	52 ³ / ₈	103 ³ / ₈	59 ³ / ₄
36	72	65 ¹ / ₄	55 ³ / ₄	99 ³ / ₈	57 ¹ / ₂	69 ⁷ / ₈	58 ³ / ₈	108 ¹ / ₂	62 ³ / ₄	

METALLIC FITTINGS

WIDTHS (W) INCHES

6 | 9 | 12 | 18 | 24 | 30 | 36

RAIL HEIGHTS (H) INCHES

4 | 5 | 6 | 7

RADIUS (R) INCHES

12 | 24 | 36

SPLICES Match above to determine the connectors you need.



SERIES1

Fitting side rails have 2" tangents (flat portion beyond curvature) at the end of each fitting, to accommodate splice plates with four holes.

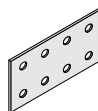

SERIES2

Fitting side rails have 5" tangents at the end of each fitting, to accommodate splice plates with eight holes.

HORIZONTAL 45° ELBOW

G L T

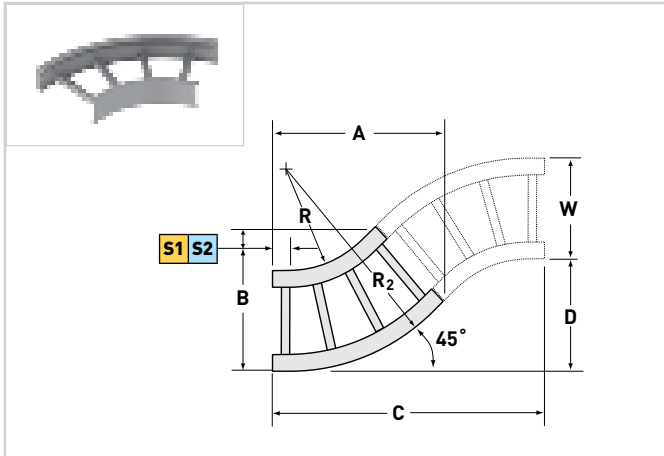

PRODUCT NUMBER RADIUS (IN.)	W	R2	SERIES1				SERIES2			
			A	B	C	D	A	B	C	D
4512 12"	6	18	16 ¹ / ₈	10 ⁷ / ₈	28	11 ⁵ / ₈	21 ¹ / ₄	13 ¹ / ₈	38 ³ / ₈	16
	9	21	18 ¹ / ₄	13 ³ / ₈	30 ¹ / ₈	12 ¹ / ₂	23 ³ / ₈	16 ¹ / ₈	40 ¹ / ₂	16 ⁷ / ₈
	12	24	20 ³ / ₈	16 ⁷ / ₈	32 ¹ / ₄	13 ³ / ₈	25 ¹ / ₂	19 ¹ / ₈	42 ⁵ / ₈	17 ³ / ₄
	18	30	24 ³ / ₈	22 ⁷ / ₈	36 ¹ / ₂	15 ¹ / ₂	29 ³ / ₄	25 ¹ / ₈	46 ⁷ / ₈	19 ¹ / ₂
	24	36	28 ⁷ / ₈	28 ⁷ / ₈	40 ³ / ₄	16 ³ / ₄	34	31 ¹ / ₈	51 ¹ / ₈	21 ¹ / ₄
	30	42	33 ¹ / ₈	34 ⁷ / ₈	45	18 ¹ / ₂	38 ¹ / ₄	37 ¹ / ₈	55 ³ / ₈	23
4524 24"	6	30	24 ⁵ / ₈	14 ¹ / ₂	45	18 ³ / ₄	29 ³ / ₄	16 ⁵ / ₈	55 ¹ / ₄	23
	9	33	26 ³ / ₄	17 ¹ / ₂	47 ¹ / ₈	19 ⁵ / ₈	31 ⁷ / ₈	19 ⁵ / ₈	57 ³ / ₈	23 ³ / ₄
	12	36	28 ⁷ / ₈	20 ¹ / ₂	49 ¹ / ₄	20 ¹ / ₂	34	22 ⁵ / ₈	59 ¹ / ₂	24 ³ / ₄
	18	42	33 ¹ / ₈	26 ¹ / ₂	53 ¹ / ₂	22 ¹ / ₄	38 ¹ / ₄	28 ³ / ₈	63 ³ / ₄	26 ³ / ₈
	24	48	37 ³ / ₈	32 ¹ / ₂	57 ³ / ₄	23 ³ / ₈	42 ¹ / ₂	34 ³ / ₈	68	28 ¹ / ₄
	30	54	41 ⁵ / ₈	38 ¹ / ₂	62	25 ⁵ / ₈	46 ³ / ₄	40 ⁵ / ₈	72 ¹ / ₄	30
4536 36"	6	42	33 ¹ / ₈	18 ¹ / ₈	62	25 ⁷ / ₈	38 ¹ / ₄	20 ⁷ / ₈	72 ¹ / ₄	29 ⁷ / ₈
	9	45	35 ¹ / ₄	21 ¹ / ₈	64 ¹ / ₈	26 ³ / ₄	40 ³ / ₈	23 ¹ / ₈	74 ³ / ₈	30 ³ / ₄
	12	48	37 ³ / ₈	24 ¹ / ₈	66 ¹ / ₄	27 ⁵ / ₈	42 ¹ / ₂	26 ¹ / ₈	76 ¹ / ₂	31 ³ / ₄
	18	54	41 ⁵ / ₈	30 ¹ / ₈	70 ¹ / ₂	29 ³ / ₈	46 ³ / ₄	32 ¹ / ₈	80 ³ / ₄	33 ³ / ₈
	24	60	45 ⁷ / ₈	36 ¹ / ₈	74 ³ / ₄	31	51	38 ¹ / ₈	85	35 ¹ / ₄
	30	66	50 ¹ / ₈	42 ¹ / ₈	79	32 ³ / ₄	55 ¹ / ₄	44 ¹ / ₈	89 ¹ / ₄	37
36	72	54 ³ / ₈	48 ¹ / ₈	83 ¹ / ₄	34 ¹ / ₂	59 ¹ / ₂	50 ¹ / ₈	93 ¹ / ₂	38 ³ / ₄	

HORIZONTAL 30° ELBOW

G L T

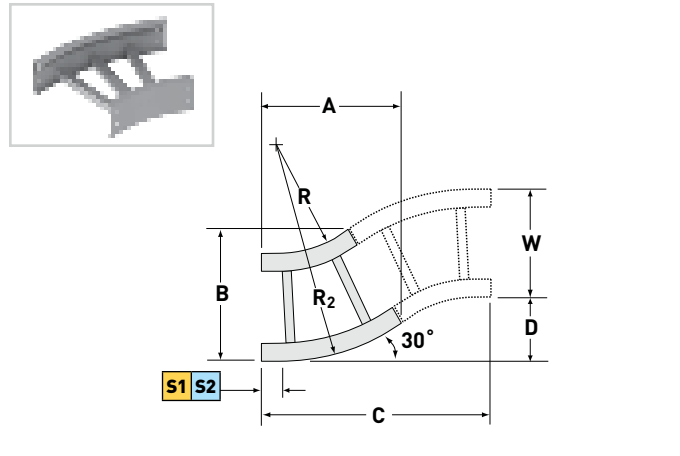

PRODUCT NUMBER RADIUS (IN.)	W	R2	SERIES1				SERIES2			
			A	B	C	D	A	B	C	D
3012 12"	6	18	12 ³ / ₄	8 ⁵ / ₈	22 ¹ / ₂	6	18 ³ / ₈	10 ¹ / ₈	33 ³ / ₄	9
	9	21	14 ¹ / ₄	11 ⁵ / ₈	24	6 ³ / ₈	19 ⁷ / ₈	13 ¹ / ₈	35 ¹ / ₄	9 ¹ / ₂
	12	24	15 ³ / ₄	14 ⁵ / ₈	25 ¹ / ₂	6 ⁷ / ₈	21 ³ / ₈	16 ¹ / ₈	36 ³ / ₄	9 ⁷ / ₈
	18	30	18 ³ / ₄	20 ⁵ / ₈	28 ¹ / ₂	7 ⁵ / ₈	24 ³ / ₈	22 ¹ / ₈	39 ³ / ₄	10 ⁵ / ₈
	24	36	21 ³ / ₄	26 ⁵ / ₈	31 ¹ / ₂	8 ³ / ₈	27 ³ / ₈	28 ¹ / ₈	42 ³ / ₄	11 ¹ / ₂
	30	42	24 ³ / ₄	32 ⁵ / ₈	34 ¹ / ₂	9 ¹ / ₄	30 ³ / ₈	34 ¹ / ₄	45 ³ / ₄	12 ³ / ₈
3024 24"	6	30	18 ³ / ₄	10 ¹ / ₄	34 ¹ / ₂	9 ¹ / ₄	24 ³ / ₈	11 ³ / ₄	45 ³ / ₄	12 ¹ / ₄
	9	33	20 ¹ / ₄	13 ¹ / ₄	36	9 ⁵ / ₈	25 ⁷ / ₈	14 ³ / ₄	47 ¹ / ₄	12 ⁵ / ₈
	12	36	21 ³ / ₄	16 ¹ / ₄	37 ¹ / ₂	10 ¹ / ₈	27 ³ / ₈	17 ¹ / ₄	48 ³ / ₄	13
	18	42	24 ³ / ₄	22 ¹ / ₄	40 ¹ / ₂	10 ⁷ / ₈	30 ³ / ₈	23 ³ / ₄	51 ³ / ₄	13 ³ / ₈
	24	48	27 ³ / ₄	28 ¹ / ₄	43 ¹ / ₂	11 ⁵ / ₈	33 ³ / ₈	29 ³ / ₄	54 ³ / ₄	14 ⁵ / ₈
	30	54	30 ³ / ₄	34 ¹ / ₄	46 ¹ / ₂	12 ¹ / ₂	36 ³ / ₈	35 ³ / ₄	57 ³ / ₄	15 ³ / ₈
3036 36"	6	42	24 ³ / ₄	11 ⁷ / ₈	46 ¹ / ₂	12 ¹ / ₂	30 ³ / ₈	13 ³ / ₈	57 ³ / ₄	15 ¹ / ₂
	9	45	26 ¹ / ₄	14 ⁷ / ₈	48	12 ⁷ / ₈	31 ⁷ / ₈	16 ³ / ₈	59 ¹ / ₄	15 ⁵ / ₈
	12	48	27 ³ / ₄	17 ¹ / ₈	49 ¹ / ₂	13 ³ / ₈	33 ³ / ₈	19 ³ / ₈	60 ³ / ₄	16 ¹ / ₄
	18	54	30 ³ / ₄	23 ¹ / ₈	52 ¹ / ₂	14 ¹ / ₈	36 ³ / ₈	25 ¹ / ₈	63 ³ / ₄	17
	24	60	33 ³ / ₄	29 ¹ / ₈	55 ¹ / ₂	14 ⁷ / ₈	39 ³ / ₈	31 ³ / ₈	66 ³ / ₄	17 ⁵ / ₈
	30	66	36 ³ / ₄	35 ¹ / ₈	58 ¹ / ₂	15 ³ / ₄	42 ³ / ₈	37 ³ / ₈	69 ³ / ₄	18 ³ / ₄
36	72	39 ³ / ₄	41 ¹ / ₈	61 ¹ / ₂	16 ¹ / ₂	45 ³ / ₈	43 ³ / ₈	72 ³ / ₄	19 ¹ / ₂	

HORIZONTAL ELBOW CATALOG NUMBERING EXAMPLE:

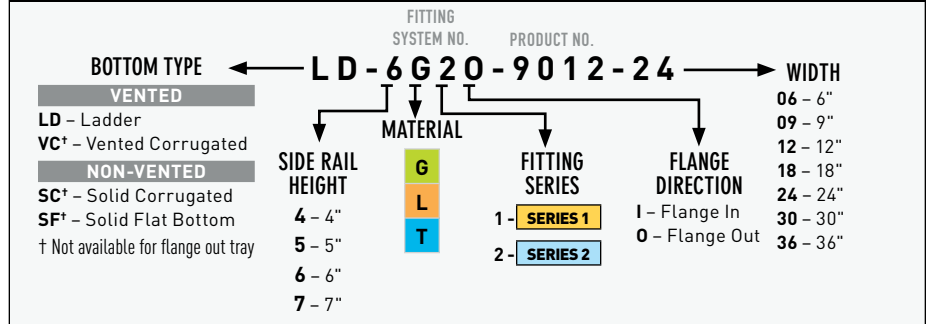

HORIZONTAL REDUCERS

G L T

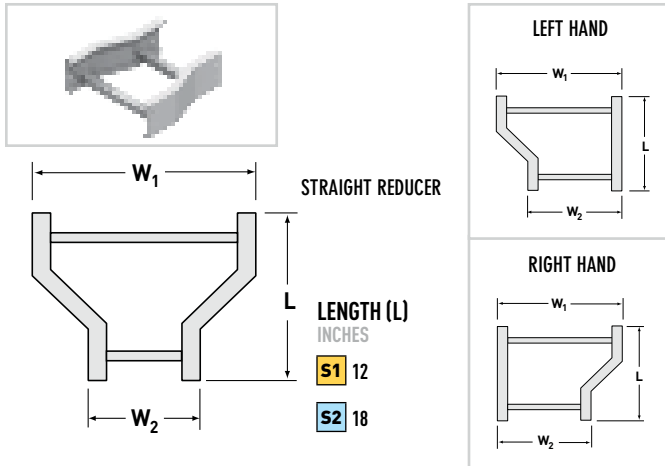

MAIN WIDTH (IN.) W1	BRANCH WIDTH (IN.) W2	PRODUCT NUMBER		
		STRAIGHT	LEFT HAND	RIGHT HAND
9	6	0109	0709	0809
12	6	0112	0712	0812
	9	0112	0712	0812
18	6	0118	0718	0818
	9	0118	0718	0818
	12	0118	0718	0818
24	6	0124	0724	0824
	9	0124	0724	0824
	12	0124	0724	0824
30	6	0130	0730	0830
	9	0130	0730	0830
	12	0130	0730	0830
	18	0130	0730	0830
	24	0130	0730	0830
36	6	0136	0736	0836
	9	0136	0736	0836
	12	0136	0736	0836
	18	0136	0736	0836
	24	0136	0736	0836
	30	0136	0736	0836

HORIZONTAL STANDARD TEE

G L T

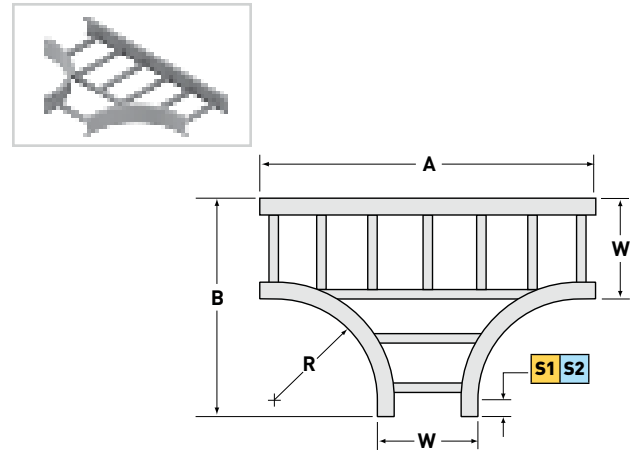

PRODUCT NUMBER RADIUS (IN.)	W	SERIES1		SERIES2	
		A	B	A	B
2012 12"	6	34	20	40	23
	9	37	23	43	26
	12	40	26	46	29
	18	46	32	52	35
	24	52	38	58	41
	30	58	44	64	47
2024 24"	6	58	32	64	35
	9	61	35	67	38
	12	64	38	70	41
	18	70	44	76	47
	24	76	50	82	53
	30	82	56	88	59
2036 36"	6	82	44	88	47
	9	85	47	91	50
	12	88	50	94	53
	18	94	56	100	59
	24	100	62	106	65
	30	106	68	112	71
36	112	74	118	77	

WIDTHS (W) INCHES

6 | 9 | 12 | 18 | 24 | 30 | 36

RAIL HEIGHTS (H) INCHES

4 | 5 | 6 | 7

RADIUS (R) INCHES

12 | 24 | 36

HORIZONTAL REDUCERS CATALOG NUMBERING EXAMPLE:

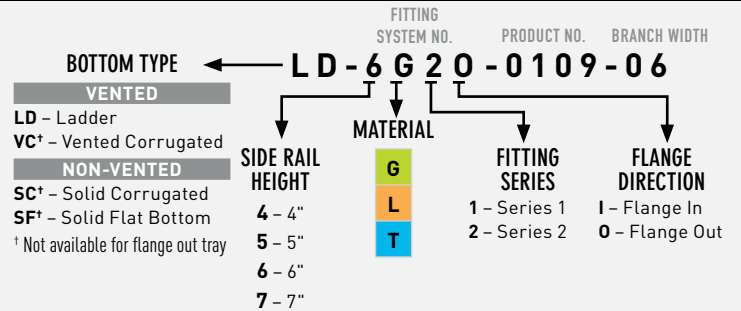

HORIZONTAL REDUCING/
EXPANDING TEES

G L T

REDUCING TEE

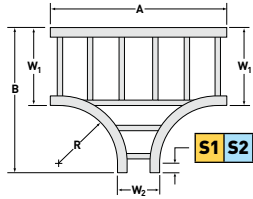

EXPANDING TEE

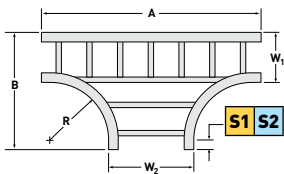

MAIN WIDTH W1	BRANCH WIDTH W2	PRODUCT NUMBER RADIUS (IN.)	SERIES1		SERIES2		PRODUCT NUMBER RADIUS (IN.)	SERIES1		SERIES2		PRODUCT NUMBER RADIUS (IN.)	SERIES1		SERIES2	
			A	B	A	B		A	B	A	B		A	B	A	B
9	6	2012 12"	34	23	40	26	2024 24"	58	35	64	38	2036 36"	82	47	88	50
12	6		34	26	40	29		58	38	64	41		82	50	88	53
	9		37	26	43	29		61	38	67	41		85	50	91	53
18	6		34	32	40	35		58	44	64	47		82	56	88	59
	9		37	32	43	35		61	44	67	47		85	56	91	59
	12		40	32	46	35		64	44	70	47		88	56	94	59
24	6		34	38	40	41		58	50	64	53		82	62	88	65
	9		37	38	43	41		61	50	67	53		85	62	91	65
	12		40	38	46	41		64	50	70	53		88	62	94	65
30	6		34	44	40	47		58	56	64	59		82	68	88	71
	9		37	44	43	47		61	56	67	59		85	68	91	71
	12		40	44	46	47		64	56	70	59		88	68	94	71
	18	46	44	52	47	70	56	76	59	94	68	100	71			
	24	52	44	58	47	76	56	82	59	100	68	106	71			
36	6	34	50	40	53	58	62	64	65	82	74	88	77			
	9	37	50	43	53	61	62	67	65	85	74	91	77			
	12	40	50	46	53	64	62	70	65	88	74	94	77			
	18	46	50	52	53	70	62	76	65	94	74	100	77			
	24	52	50	58	53	76	62	82	65	100	74	106	77			
	30	58	50	64	53	82	62	88	65	106	74	112	77			
6	9	2012 12"	37	20	43	23	2024 24"	61	32	67	35	2036 36"	85	44	91	47
	12		40	20	46	23		64	32	70	35		88	44	94	47
	18		46	20	52	23		70	32	76	35		94	44	100	47
	24		52	20	58	23		76	32	82	35		100	44	106	47
	30		58	20	64	23		82	32	88	35		106	44	112	47
36	64		20	70	23	88		32	94	35	112		44	118	47	
9	12		40	23	46	26		64	35	70	38		88	47	94	50
	18		46	23	52	26		70	35	76	38		94	47	100	50
	24		52	23	58	26		76	35	82	38		100	47	106	50
	30		58	23	64	26		82	35	88	38		106	47	112	50
12	36		64	23	70	26		88	35	94	38		112	47	118	50
	18		46	26	52	29		70	38	76	41		94	50	100	53
	24	52	26	58	29	76	38	82	41	100	50	106	53			
	30	58	26	64	29	82	38	88	41	106	50	112	53			
18	36	64	26	70	29	88	38	94	41	112	50	118	53			
	24	52	32	58	35	76	44	82	47	100	56	106	59			
	30	58	32	64	35	82	44	88	47	106	56	112	59			
24	36	64	32	70	35	88	44	94	47	112	56	118	59			
	30	58	38	64	41	82	50	88	53	106	62	112	65			
30	36	64	38	70	41	88	50	94	53	112	62	118	65			
	36	64	44	70	47	88	56	94	59	112	68	118	71			

REDUCING TEE CATALOG NUMBERING EXAMPLE:

LD - 6 G 2 0 - 2012 - 24 12 †

BOTTOM TYPE
 LD - Ladder
 VC† - Vented Corrugated
NON-VENTED
 SC† - Solid Corrugated
 SF† - Solid Flat Bottom
 † Not available for flange out tray

SIDE RAIL HEIGHT
 4 - 4"
 5 - 5"
 6 - 6"
 7 - 7"

MATERIAL
 G
 L
 T

FITTING SYSTEM NO.
 1 - SERIES 1
 2 - SERIES 2

PRODUCT NO.
 I - Flange In
 O - Flange Out

MAIN WIDTH
 W1 (W2)
 06 - 6"
 09 - 9"
 12 - 12"
 18 - 18"
 24 - 24"
 30 - 30"
 36 - 36"

† W2 applies only to reducing and expanding tees.



HORIZONTAL CROSSES

G L T

STANDARD CROSS

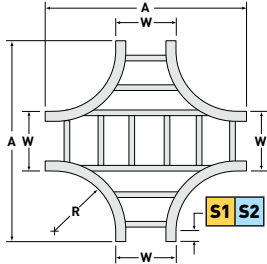
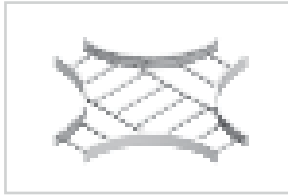

W	PRODUCT NUMBER RADIUS (IN.)	SERIES 1	SERIES 2	PRODUCT NUMBER RADIUS (IN.)	SERIES 1	SERIES 2	PRODUCT NUMBER RADIUS (IN.)	SERIES 1	SERIES 2
		A	A		A	A		A	A
6	1012 12"	34	40	1024 24"	58	64	1036 36"	82	88
9		37	43		61	67		85	91
12		40	46		64	70		88	94
18		46	52		70	76		94	100
24		52	58		76	82		100	106
30		58	64		82	88		106	112
36	64	70	88	94	112	118			

REDUCING CROSS

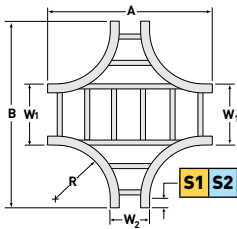

MAIN WIDTH W1	BRANCH WIDTH W2	PROD. NUM. RADIUS	SERIES 1	SERIES 2	PROD. NUM. RADIUS	SERIES 1	SERIES 2	PROD. NUM. RADIUS	SERIES 1	SERIES 2						
			A	B		A	B		A	B	A	B				
9	6	1012 12"	34	37	1024 24"	58	61	1036 36"	82	85	88	91				
	6		34	40		40	46		58	64	64	70	82	88	88	94
	9		37	40		43	46		61	64	67	70	85	88	91	94
12	6		34	46		40	52		58	70	64	76	82	94	88	100
	9		37	46		43	52		61	70	67	76	85	94	91	100
	12		40	46		46	52		64	70	70	76	88	94	94	100
18	6		34	52		40	58		58	76	64	82	82	100	88	106
	9		37	52		43	58		61	76	67	82	85	100	91	106
	12		40	52		46	58		64	76	70	82	88	100	94	106
24	6		46	52		52	58		70	76	76	82	94	100	100	106
	9		34	58		40	64		58	82	64	88	82	106	88	112
	12		37	58		43	64		61	82	67	88	85	106	91	112
30	6	40	58	46	64	64	82	70	88	88	106	94	112			
	9	46	58	52	64	70	82	76	88	94	106	100	112			
	12	52	58	58	64	76	82	82	88	100	106	106	112			
36	6	34	64	40	70	58	88	64	94	82	112	88	118			
	9	37	64	43	70	61	88	67	94	85	112	91	118			
	12	40	64	46	70	64	88	70	94	88	112	94	118			
18	6	46	64	52	70	70	88	76	94	94	112	100	118			
	9	52	64	58	70	76	88	82	94	100	112	106	118			
	12	58	64	64	70	82	88	88	94	106	112	106	118			
24	6	58	64	64	70	82	88	88	94	106	112	106	118			
	9	64	64	64	70	88	88	88	94	112	112	106	118			
	12	70	64	64	70	88	88	88	94	112	112	106	118			

METALLIC FITTINGS

WIDTHS (W) INCHES

6 | 9 | 12 | 18 | 24 | 30 | 36

RAIL HEIGHTS (H) INCHES

4 | 5 | 6 | 7

RADIUS (R) INCHES

12 | 24 | 36

REDUCING CROSS CATALOG NUMBERING EXAMPLE:

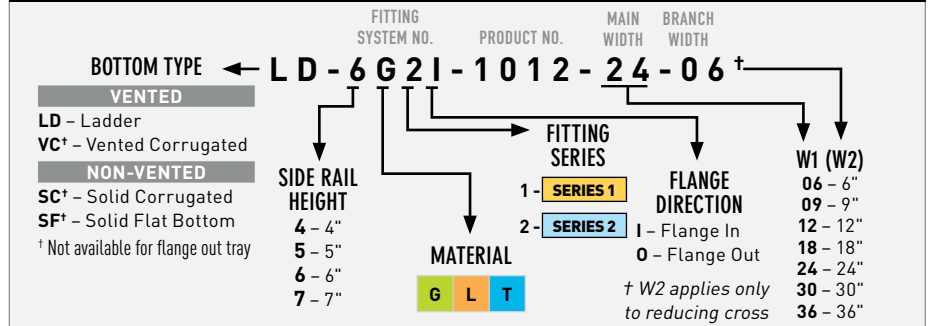

HORIZONTAL WYE BRANCHES G L T

LEFT HAND

RIGHT HAND

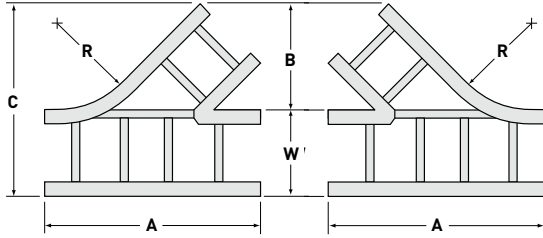
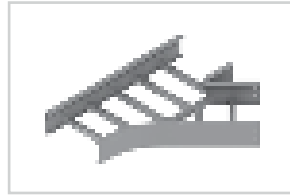
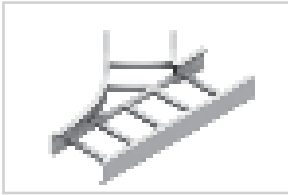

W	PRODUCT NUMBER		SERIES 1			SERIES 2		
	LH RADIUS (IN.)	RH RADIUS (IN.)	A	B	C	A	B	C
6	4024 24"	4124 24"	26 ³ / ₈	10 ¹ / ₄	16 ¹ / ₄	29 ³ / ₈	10 ¹ / ₄	16 ¹ / ₄
9			30 ³ / ₈	12 ³ / ₈	21 ³ / ₈	33 ³ / ₈	12 ³ / ₈	21 ³ / ₈
12			34 ⁷ / ₈	14 ¹ / ₂	26 ¹ / ₂	37 ⁷ / ₈	14 ¹ / ₂	26 ¹ / ₂
18			43 ³ / ₈	18 ³ / ₄	36 ³ / ₄	46 ³ / ₈	18 ³ / ₄	36 ³ / ₄
24			51 ⁷ / ₈	23	47	54 ⁷ / ₈	23	47
30			60 ³ / ₈	27 ¹ / ₄	57 ¹ / ₄	63 ³ / ₈	27 ¹ / ₄	57 ¹ / ₄
36			68 ⁷ / ₈	31 ¹ / ₂	67 ¹ / ₂	71 ⁷ / ₈	31 ¹ / ₂	67 ¹ / ₂

HORIZONTAL ADJUSTABLE ELBOW G L T

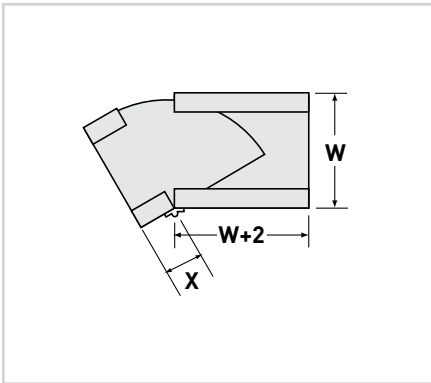

PRODUCT NUMBER	W	SERIES 1	SERIES 2
		X	X
0401	6	4	7
	9	4	7
	12	4	7
	18	4	7
	24	4	7
	30	4	7
	36	4	7

HORIZONTAL WYE BRANCH CATALOG NUMBERING EXAMPLE:

FITTING SYSTEM NO. PRODUCT NO.

LD - 6 G 2 0 - 4 0 2 4 - 2 4

BOTTOM TYPE

VENTED

LD - Ladder

VC* - Vented Corrugated

NON-VENTED

SC* - Solid Corrugated

SF* - Solid Flat Bottom

* Not available for flange out tray

SIDE RAIL HEIGHT

4 - 4"

5 - 5"

6 - 6"

7 - 7"

FITTING SERIES

1 - SERIES 1

2 - SERIES 2

MATERIAL

G L T

FLANGE DIRECTION

I - Flange In

O - Flange Out

WIDTH

06 - 6"

09 - 9"

12 - 12"

18 - 18"

24 - 24"

30 - 30"

36 - 36"



VERTICAL OUTSIDE 90° ELBOW

G L T

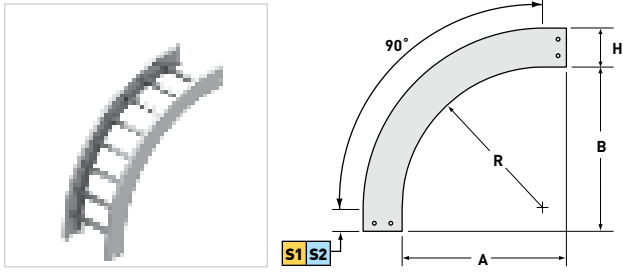

RAIL HEIGHT (IN.) >		4, 5, 6, 7			
PRODUCT NUMBER RADIUS (IN.)	W*	SERIES 1		SERIES 2	
		A	B	A	B
9212 12"	ALL	14	14	17	17
9224 24"	ALL	26	26	29	29
9236 36"	ALL	38	38	41	41

VERTICAL OUTSIDE 60° ELBOW

G L T

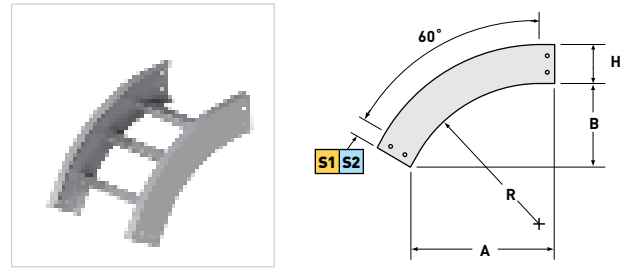

RAIL HEIGHT (IN.) >		4, 5, 6, 7			
PRODUCT NUMBER RADIUS (IN.)	W*	SERIES 1		SERIES 2	
		A	B	A	B
6212 12"	ALL	13 1/2	7 3/4	18	1 3/8
6224 24"	ALL	23 7/8	13 3/4	28 7/8	16 3/8
6236 36"	ALL	34 1/4	19 3/4	38 3/4	22 3/8

VERTICAL OUTSIDE 45° ELBOW

G L T

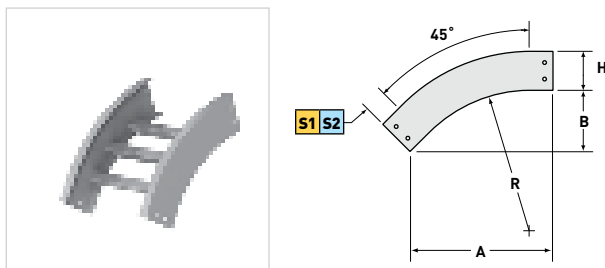

RAIL HEIGHT (IN.) >		4, 5, 6, 7			
PRODUCT NUMBER RADIUS (IN.)	W*	SERIES 1		SERIES 2	
		A	B	A	B
4712 12"	ALL	12	5	17 1/8	7 1/8
4724 24"	ALL	20 1/2	8 1/2	25 5/8	10 5/8
4736 36"	ALL	28 7/8	12	34	14 1/8

VERTICAL OUTSIDE 30° ELBOW

G L T

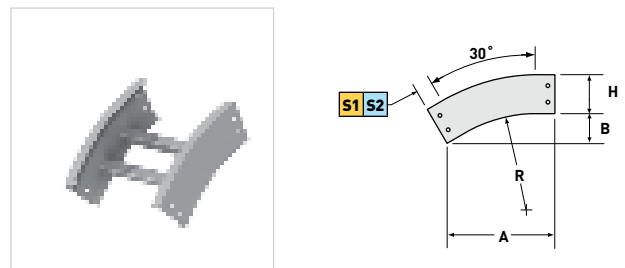

RAIL HEIGHT (IN.) >		4, 5, 6, 7			
PRODUCT NUMBER RADIUS (IN.)	W*	SERIES 1		SERIES 2	
		A	B	A	B
3212 12"	ALL	9 3/4	2 5/8	15 5/8	4 1/8
3224 24"	ALL	15 3/4	4 1/4	21 3/8	5 3/4
3236 36"	ALL	21 3/4	5 7/8	27 3/8	7 3/8

METALLIC FITTINGS

WIDTHS (W) INCHES

6 | 9 | 12 | 18 | 24 | 30 | 36

RAIL HEIGHTS (H) INCHES

4 | 5 | 6 | 7

RADIUS (R) INCHES

12 | 24 | 36

SPLICES Match above to determine the connectors you need.



SERIES 1

Fitting side rails have 2" tangents (flat portion beyond curvature) at the end of each fitting, to accommodate splice plates with four holes.

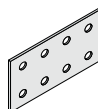

SERIES 2

Fitting side rails have 5" tangents at the end of each fitting, to accommodate splice plates with eight holes.



VERTICAL INSIDE 90° ELBOW G L T

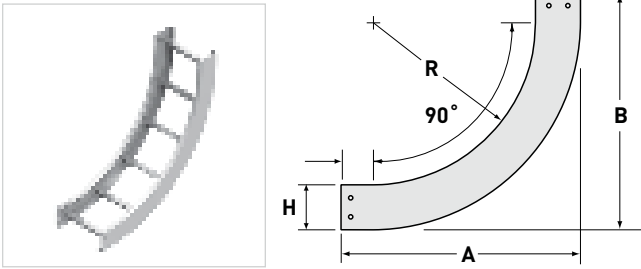

VERTICAL INSIDE 60° ELBOW G L T

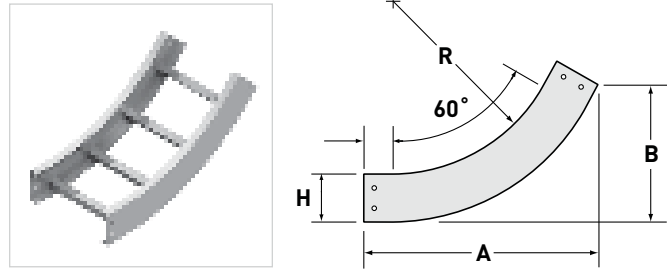

VERTICAL INSIDE 45° ELBOW G L T

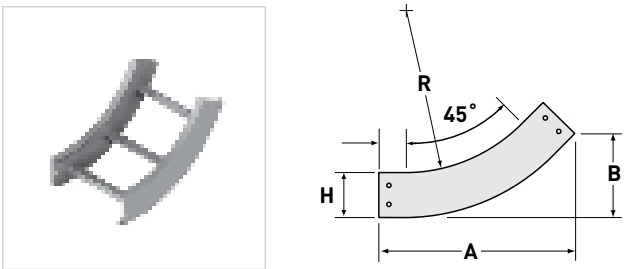

VERTICAL INSIDE 30° ELBOW G L T

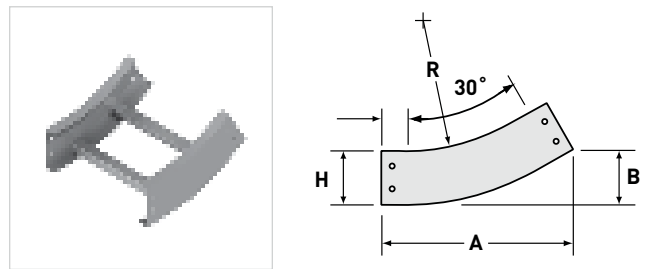

RAIL HEIGHT >			4		5		6		7										
PRODUCT NUMBER	RADIUS (IN.)	R	W	SERIES 1		SERIES 2		SERIES 1		SERIES 2		SERIES 1		SERIES 2		SERIES 1		SERIES 2	
				A	B	A	B	A	B	A	B	A	B	A	B	A	B	A	B
90°	9112	12	ALL	18	18	21	21	19	19	22	22	20	20	23	23	21	21	24	24
	9124	24	ALL	30	30	33	33	31	31	34	34	32	32	35	35	33	33	36	36
	9136	36	ALL	42	42	45	45	43	43	46	46	44	44	47	47	45	45	48	48
60°	6112	12	ALL	16 ⁷ / ₈	9 ³ / ₄	21 ³ / ₈	12 ³ / ₈	17 ³ / ₄	10 ¹ / ₄	22 ¹ / ₄	12 ¹ / ₈	18 ⁵ / ₈	10 ³ / ₄	23 ³ / ₈	13 ³ / ₈	19 ¹ / ₂	11 ¹ / ₄	24	13 ⁷ / ₈
	6124	24	ALL	27 ¹ / ₄	15 ³ / ₄	31 ³ / ₄	18 ³ / ₈	28 ¹ / ₈	16 ¹ / ₄	32 ³ / ₈	18 ⁷ / ₈	29	16 ³ / ₄	33 ¹ / ₂	19 ³ / ₈	29 ⁷ / ₈	17 ¹ / ₄	34 ³ / ₈	19 ⁷ / ₈
	6136	36	ALL	37 ³ / ₄	21 ³ / ₄	42 ¹ / ₄	24 ³ / ₈	38 ⁵ / ₈	22 ¹ / ₄	43 ¹ / ₈	24 ⁷ / ₈	39 ³ / ₈	22 ³ / ₄	43 ⁷ / ₈	25 ⁵ / ₈	40 ¹ / ₄	23 ¹ / ₄	44 ³ / ₄	25 ⁷ / ₈
45°	4612	12	ALL	14 ³ / ₄	6 ¹ / ₈	19 ⁷ / ₈	8 ¹ / ₄	15 ¹ / ₂	6 ¹ / ₂	20 ⁵ / ₈	8 ⁵ / ₈	16 ¹ / ₄	6 ³ / ₄	21 ³ / ₈	8 ⁷ / ₈	16 ⁷ / ₈	7	22	9 ¹ / ₈
	4624	24	ALL	23 ¹ / ₄	9 ⁵ / ₈	28 ³ / ₈	11 ³ / ₄	24	10	29 ¹ / ₈	12 ¹ / ₈	24 ⁵ / ₈	10 ¹ / ₄	29 ³ / ₄	12 ³ / ₈	25 ³ / ₈	10 ¹ / ₂	30 ¹ / ₂	12 ⁵ / ₈
	4636	36	ALL	31 ³ / ₄	13 ¹ / ₄	36 ⁷ / ₈	15 ¹ / ₄	32 ¹ / ₂	13 ¹ / ₂	37 ⁵ / ₈	15 ⁵ / ₈	33 ¹ / ₈	13 ³ / ₄	38 ¹ / ₄	15 ⁷ / ₈	33 ⁷ / ₈	14	39	16 ¹ / ₄
30°	3112	12	ALL	11 ³ / ₄	3 ¹ / ₄	17 ³ / ₈	4 ³ / ₄	12 ¹ / ₄	3 ¹ / ₄	17 ⁷ / ₈	4 ¹ / ₄	12 ³ / ₄	3 ³ / ₈	18 ³ / ₈	4 ⁷ / ₈	13 ¹ / ₄	3 ³ / ₈	18 ⁷ / ₈	5 ¹ / ₈
	3124	24	ALL	17 ³ / ₄	4 ³ / ₄	23 ³ / ₈	6 ¹ / ₄	18 ¹ / ₄	4 ⁷ / ₈	23 ⁷ / ₈	6 ³ / ₈	18 ³ / ₄	5	24 ³ / ₈	6 ¹ / ₂	19 ¹ / ₄	5 ¹ / ₄	24 ⁷ / ₈	6 ³ / ₄
	3136	36	ALL	23 ³ / ₄	6 ³ / ₈	29 ³ / ₈	7 ¹ / ₈	24 ¹ / ₄	6 ¹ / ₂	29 ⁷ / ₈	8	24 ³ / ₄	6 ⁵ / ₈	30 ³ / ₈	8 ¹ / ₈	25 ¹ / ₄	6 ⁷ / ₈	30 ⁷ / ₈	8 ³ / ₈

VERTICAL ELBOW CATALOG NUMBERING EXAMPLE:

FITTING SYSTEM NO. PRODUCT NO.

LD - 6 G 2 I - 6 1 2 4 - 2 4

BOTTOM TYPE

VENTED

LD - Ladder

VC⁺ - Vented Corrugated

NON-VENTED

SC⁺ - Solid Corrugated

SF⁺ - Solid Flat Bottom

¹ Not available for flange out tray

SIDE RAIL HEIGHT

4 - 4"

5 - 5"

6 - 6"

7 - 7"

WIDTH

06 - 6"

09 - 9"

12 - 12"

18 - 18"

24 - 24"

30 - 30"

36 - 36"

MATERIAL

G L T

FITTING SERIES

1 - SERIES 1

2 - SERIES 2

FLANGE DIRECTION

I - Flange In

O - Flange Out



VERTICAL TEES

G L T

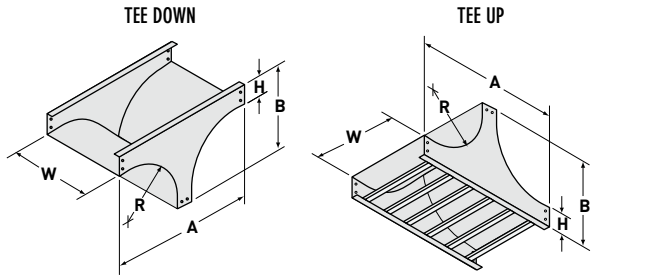

TEE UP fittings have rungs or bottom members for cable support across the bottom of the fitting.

PRODUCT NUMBER RADIUS (IN.)		W	H	SERIES 1		SERIES 2	
TEE DOWN	TEE UP			A	B	A	B
2124 24"	2224 24"	ALL	4	56	30	62	33
			5	57	31	63	34
			6	58	32	64	35
			7	59	33	65	36

VERTICAL CROSS

G L T

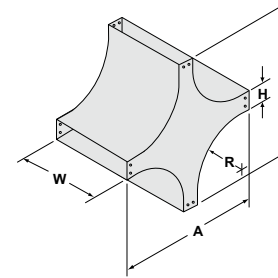

PRODUCT NUMBER RADIUS (IN.)	W	H	SERIES 1	SERIES 2
			A	A
1124 24"	ALL	4	56	62
		5	57	63
		6	58	64
		7	59	65

VERTICAL 90° SUPPORT ELBOW

G L T

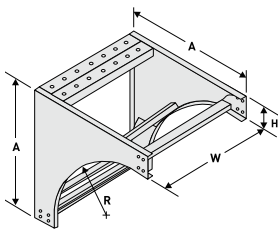

PRODUCT NUMBER RADIUS	W	H	SERIES 2
			A
9312 12"	ALL	4	21
		5	22
		6	23
		7	24
9324 24"	ALL	4	33
		5	34
		6	35
		7	36
9336 36"	ALL	4	45
		5	46
		6	47
		7	48

Supports cables at the top of long vertical drops where the weight of the vertical cable may be excessive. Hooks (sold separately) attach to the brace in the elbow; when used with cable grips (supplied by others), tension in the vertical cable is relieved and transferred to the elbow.

CABLE SUPPORT HOOK

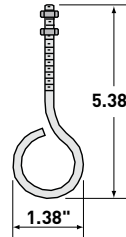

COMPLETE CATALOG NO.

DS-1841-ZN

Itray
COMPATIBLE

WIDTHS (W) INCHES

6 | 9 | 12 | 18 | 24 | 30 | 36

RAIL HEIGHTS (H) INCHES

4 | 5 | 6 | 7

RADIUS (R) INCHES

12 | 24 | 36

VERTICAL TEE DOWN CATALOG NUMBERING EXAMPLE:

FITTING SYSTEM NO. PRODUCT NO.

LD - 6 G 2 I - 2 1 2 4 - 2 4

← BOTTOM TYPE →

VENTED
LD - Ladder
VC† - Vented Corrugated
NON-VENTED
SC† - Solid Corrugated
SF† - Solid Flat Bottom
† Not available for flange out tray

SIDE RAIL HEIGHT
4 - 4"
5 - 5"
6 - 6"
7 - 7"

MATERIAL
G L T

FITTING SERIES
1 - SERIES 1
2 - SERIES 2

WIDTH
06 - 6"
09 - 9"
12 - 12"
18 - 18"
24 - 24"
30 - 30"
36 - 36"

FLANGE DIRECTION
I - Flange In
O - Flange Out

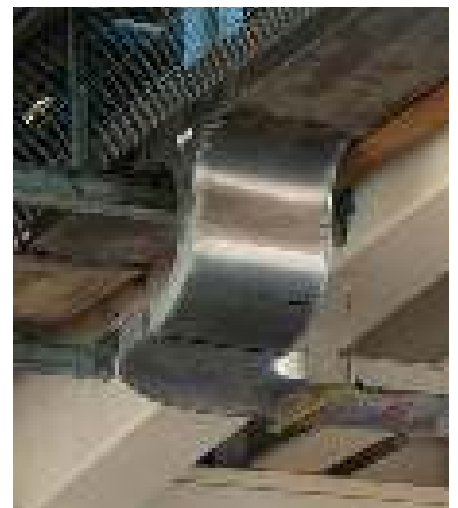

METALLIC

B.41



TRAY COVERS

SOLID COVERS

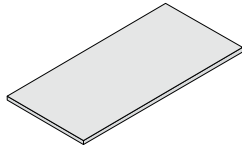

FLAT, NON-FLANGED

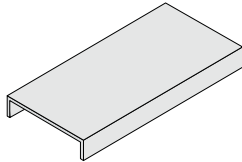

FLAT, FLANGED

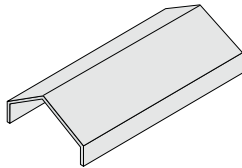

PEAKED 15°, FLANGED

LOUVERED COVERS

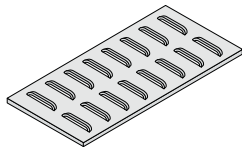

FLAT, NON-FLANGED

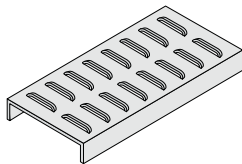

FLAT, FLANGED

Covers protect and contain cables. They are highly recommended to avoid damage to the tray contents and to protect against the elements. Some covers can also be attached to the tray with hinges; please contact Legrand for more information.

	FLANGE IN	1 3/4" FLANGE OUT
		SERIES 2
	[]	[]
	SOLID, FLAT — NON-FLANGED PRODUCT NUMBER	
M	2002	2067
L	3002	3038
T	3042	3039
	SOLID, FLAT — FLANGED* PRODUCT NUMBER	
M	2000	2066
G	1000	1066
L	3000	3036
T	3005	3029
	SOLID, PEAKED 15° — FLANGED† PRODUCT NUMBER	
M	2140	2114
G	1140	1114
L	3128	3131
T	3017	3040
	LOUVERED, FLAT — NON-FLANGED PRODUCT NUMBER	
M	2006	2112
L	3050	3117
T	3041	3112
	LOUVERED, FLAT — FLANGED* PRODUCT NUMBER	
M	2007	2104
G	1007	1104
L	3070	3003
T	3076	3113

WIDTHS (W) INCHES

6 | 9 | 12 | 18 | 24 | 30 | 36

RAIL HEIGHTS (H) INCHES

4 | 5 | 6 | 7

* Flange is 3/8" wide.

† 15° is standard angle for peaked covers. Flange is 3/8" wide.

COVER CATALOG NUMBERING EXAMPLE:

COVER SYSTEM NO. 60 - **LENGTH OR FITTING PRODUCT NO.** 2000 - 0012 - **WIDTH** 36 - **FITTING TANGENT** 05 - **COVER THICKNESS** B

SIDE RAIL HEIGHT* ← 60 - 2000 - 0012 - 36 - 05 - B → COVER THICKNESS

40 - 4"
 50 - 5"
 60 - 6"
 70 - 7"

LENGTH 0006** - 6'
 0010 - 10'
 0012 - 12'
 or
9224
 FITTING PRODUCT NO.

WIDTH 36
 FITTING TANGENT 05 - **SERIES 2** (5" Tangents)

Letter suffixes are used to indicate alternate cover thicknesses. Leave blank for standard thickness.

Standards:
G 18 Ga.
M L T 20 Ga.
A - 18 Gage (0.048")
B - 16 Gage (0.060")
C - 14 Gage (0.075")

* Side rail height necessary for outside vertical fitting covers.
 ** Standard length for steel covers hot-dip galvanized after fabrication per ASTM-A-123 is 6'-0".

METALLIC COVERS

FLAT COVER CONNECTORS

M T G*

For use with indoor, outdoor, or vertical flat covers. Top and bottom pieces are 1½" wide. Install one connector over each cover joint and space additional connectors on 36" - 48" centers.

CHANNEL-STYLE

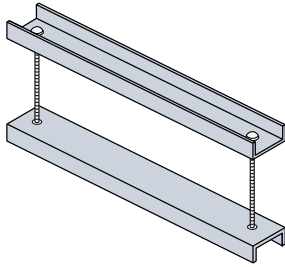

APPLICATION

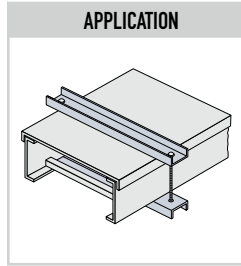

STRAP-STYLE

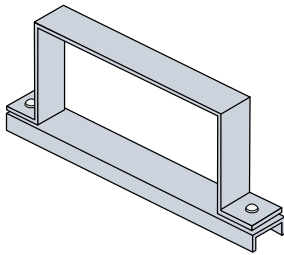

APPLICATION

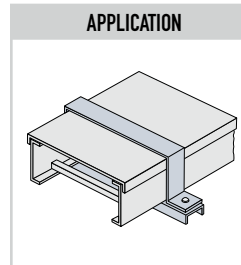

DESCRIPTION	PRODUCT NUMBER	FASTENERS
CHANNEL	1400	ZN S6
STRAP	1423	GE S6

PEAKED COVER CONNECTORS

M T G*

For use with indoor, outdoor, or vertical peaked covers. Top and bottom pieces are 1½" wide. Install one connector over each cover joint and space additional connectors on 36" - 48" centers.

CHANNEL-STYLE

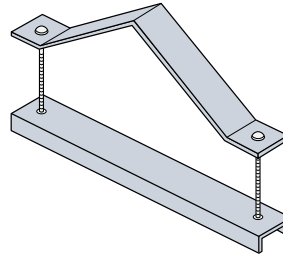

APPLICATION

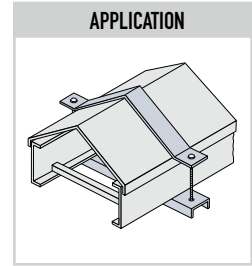

STRAP-STYLE

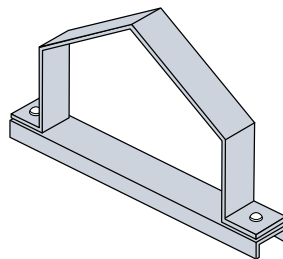

APPLICATION

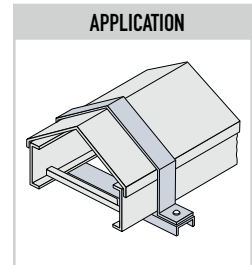

DESCRIPTION	PRODUCT NUMBER	FASTENERS
CHANNEL	1411	ZN S6
STRAP	1440	GE S6

SPLICES Match above to determine the connectors you need.



SERIES1

Fitting side rails have 2" tangents (flat portion beyond curvature) at the end of each fitting, to accommodate splice plates with four holes.

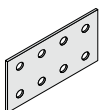

SERIES2

Fitting side rails have 5" tangents at the end of each fitting, to accommodate splice plates with eight holes.

COVER CONNECTOR CATALOG NUMBERING EXAMPLE:

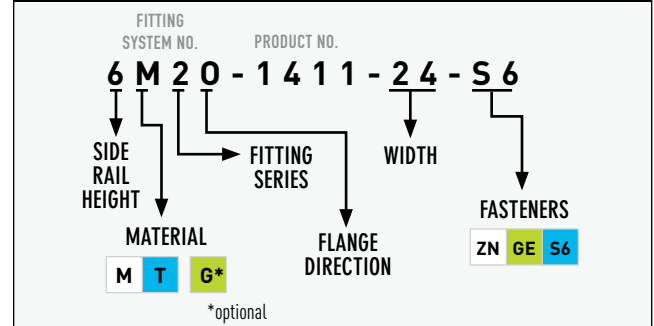

COVER CONNECTOR CLIPS

T

For use with indoor, horizontal covers. Flange-in clip requires tray with 1" side rail flanges. Flange-out clip works with any side rail flange width. Sold individually.

FLANGE-IN CLIP

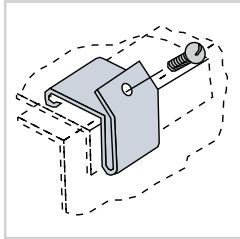

FLANGE-OUT CLIP

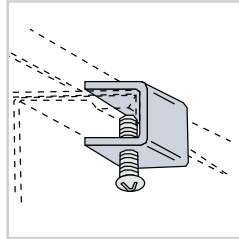

DESCRIPTION	PRODUCT NUMBER	FASTENER INCLUDED
FLANGE-IN	1410	S6
FLANGE-OUT	1853	
CATALOG NUMBERING EXAMPLE (EA.):		
Material	Fasteners	
T	1410	-S6

Itray
COMPATIBLE

H-BINDER COVER JOINT STRIP

A

Closes gaps at cover joints. Notched for the tray side rail. No fasteners required.

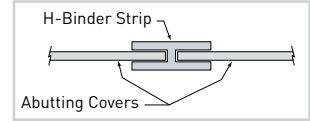
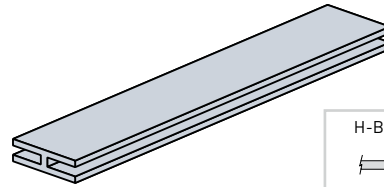

DESCRIPTION	PRODUCT NUMBER
FLAT COVER CLIP	0925
PEAKED COVER CLIP	0926
CATALOG NUMBERING EXAMPLE (EA.):	
Connector System No. [†]	Width
A20	-0925-06
[†] A1, A10 and A20 are the only three Connector System No. possibilities for this part.	
Al is Itray COMPATIBLE	

RAISED COVER CONNECTOR

M T G*

For use with all covers, indoors and outdoors. Covers are attached to uprightmounted "C" channel on the top of the cable tray. Install 36"-48" on center.

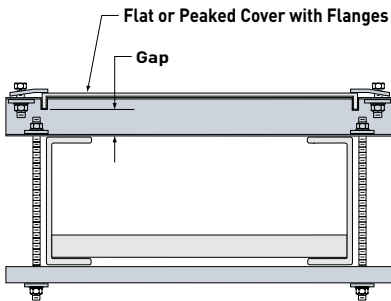

GAP DIMENSION (IN.)	PRODUCT NUMBER	FASTENER OPTIONS
1	1441	ZN S6
2	1442	
3	1443	
4	1444	
CATALOG NUMBERING EXAMPLE (EA.):		
Fitting System No.	Width	Fasteners
6T20	-1441	-06-S6

RAISED COVER CONNECTOR

A M T

Raised cover connectors allow for ventilation of ladder tray installations while protecting cables from possible falling objects. Raised cover connectors allow a gap of 1", 2", 3" or 4".



Itray
COMPATIBLE

PRODUCT NUMBER	FASTENER INCLUDED
1432	S6
CATALOG NUMBERING EXAMPLE (EA.):	
Material	Fasteners
M	-1432-S6

APPLICATION



RAIL HEIGHTS (H) INCHES

4 | 5 | 6 | 7



Cadmium-plated steel fasteners are standard for all splice plate connectors on aluminum and steel cable tray systems. **All splices are supplied in pairs.** Type 316 stainless steel fasteners are standard on stainless steel systems, but are available as an option on all aluminum and steel systems. Sufficient connector pairs with fasteners are automatically included with each shipment of straight sections and fittings. Extras for field cuts or spares must be ordered separately. Bonding jumpers are required for all expansion splice plates, adjustable connectors, and tray discontinuities. The symbol indicates that bonding jumpers are required.

STANDARD SPLICE G T

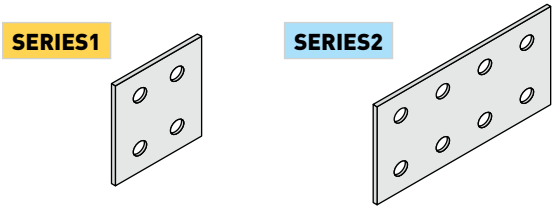

PRODUCT NUMBER	FASTENER OPTIONS
1302	GE S6
CATALOG NUMBERING EXAMPLE:	
Connector System No.	Fasteners
4 G 1 - 1302 - GE	

MID-SPAN SPLICE G T

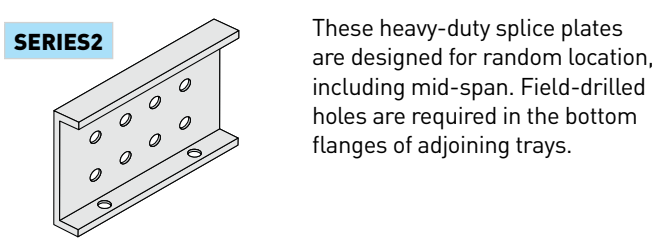

These heavy-duty splice plates are designed for random location, including mid-span. Field-drilled holes are required in the bottom flanges of adjoining trays.

PRODUCT NUMBER	FASTENER OPTIONS
1385	GE S6
CATALOG NUMBERING EXAMPLE:	
Connector System No.†	Fasteners
4 G 2 - 1385 - S 6	
†This item must be specified as Series 2 in the System No.	

UNIVERSAL SPLICE G T

These splice plates are designed to connect to existing cable tray.

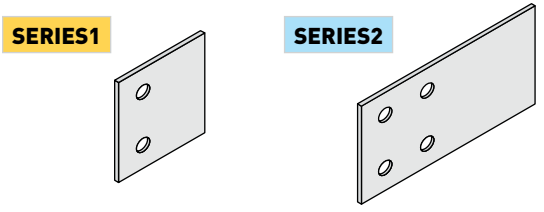

PRODUCT NUMBER	FASTENER OPTIONS
1335	GE S6
CATALOG NUMBERING EXAMPLE:	
Connector System No.†	Fasteners
4 G 1 - 1335 - GE	

REDUCING HEIGHT SPLICE G T

These splice plates are designed to connect cable tray side rails with different heights. The connector system number includes the larger side rail height. Choose the product number depending on the reduced side rail height.

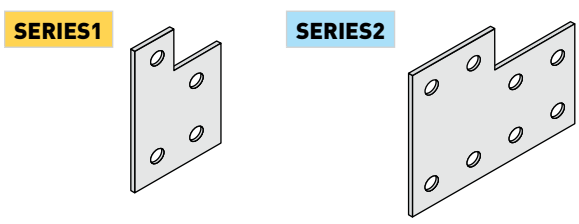

PRODUCT NUMBER	SIZE	FASTENER OPTIONS
1386	REDUCES TO 4" HIGH TRAY	GE S6
1379	REDUCES TO 5" HIGH TRAY	
1355	REDUCES TO 6" HIGH TRAY	
CATALOG NUMBERING EXAMPLE:		
Connector System No.	Fasteners	
6 G 2 - 1386 - GE		

SPLICES Match above to determine the connectors you need.

- SERIES1**
Fitting side rails have 2" tangents (flat portion beyond curvature) at the end of each fitting, to accommodate splice plates with four holes.
- SERIES2**
Fitting side rails have 5" tangents at the end of each fitting, to accommodate splice plates with eight holes.

Cadmium-plated steel fasteners are standard for all splice plate connectors on aluminum and steel cable tray systems. **All splices are supplied in pairs.** Type 316 stainless steel fasteners are standard on stainless steel systems, but are available as an option on all aluminum and steel systems. Sufficient connector pairs with fasteners are automatically included with each shipment of straight sections and fittings. Extras for field cuts or spares must be ordered separately. Bonding jumpers are required for all expansion splice plates, adjustable connectors, and tray discontinuities. The  symbol indicates that bonding jumpers are required.

EXPANSION SPLICE

G T

SERIES1
SERIES2

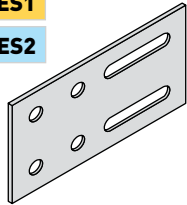

Permits thermal contraction and expansion in a cable tray installation. The length of the straight cable tray run and the temperature differential govern the number and spacing of expansion connectors. Expansion splice plates permit 2" of movement.

PRODUCT NUMBER	FASTENER OPTIONS
1314	GE S6
CATALOG NUMBERING EXAMPLE:	
Connector System No.	Fasteners
4 G 2 - 1314	- G E



STRAIGHT REDUCER SPLICE

G T

SERIES1
SERIES2

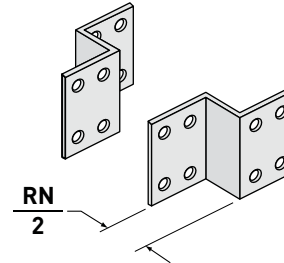

PRODUCT NUMBER	FASTENER OPTIONS
1303	GE S6
CATALOG NUMBERING EXAMPLE:	
Connector System No.	RN Fasteners
4 G 2 - 1303	- 0 6 - G E

OFFSET REDUCER SPLICE

G T

SERIES1
SERIES2

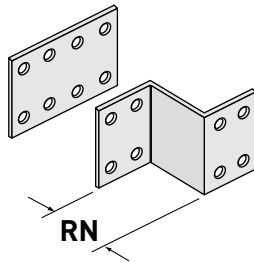

PRODUCT NUMBER	FASTENER OPTIONS
1304	GE S6
CATALOG NUMBERING EXAMPLE:	
Connector System No.	RN Fasteners
4 G 2 - 1304	- 1 2 - S 6

90° CONNECTOR

G T

SERIES1
SERIES2

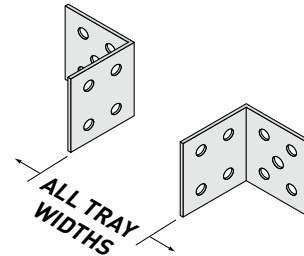

PRODUCT NUMBER	FASTENER OPTIONS
1320	GE S6
CATALOG NUMBERING EXAMPLE:	
Connector System No.	Fasteners
4 G 2 - 1320	- G E

WIDTHS (W) INCHES

6 | 9 | 12 | 18 | 24 | 30 | 36

RAIL HEIGHTS (H) INCHES

4 | 5 | 6 | 7

REDUCTION (RN) INCHES

3 | 6 | 9 | 12 | 15 | 18 | 21 | 24 | 27 | 30

SPLICES Match above to determine the connectors you need.



SERIES1

Fitting side rails have 2" tangents (flat portion beyond curvature) at the end of each fitting, to accommodate splice plates with four holes.

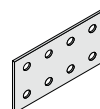

SERIES2

Fitting side rails have 5" tangents at the end of each fitting, to accommodate splice plates with eight holes.



All splices are supplied in pairs. Bonding jumpers are required for use with all adjustable splices.

FLOOR FLANGE / TRAY-TO-BOX CONNECTOR G T

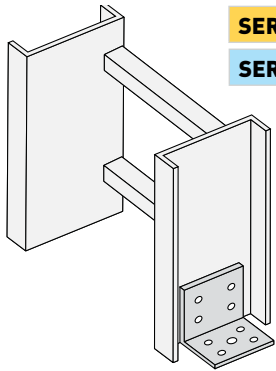

SERIES1
SERIES2

Fasteners for tray attachment only are included. Floor connection leg has $\frac{9}{16}$ " diameter hole.

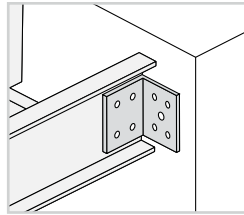

PRODUCT NUMBER	FASTENER OPTIONS
1864	GE S6
CATALOG NUMBERING EXAMPLE:	
Connector System No.	Fasteners
4 G 2 - 1864	- G E

HORIZONTAL ADJUSTABLE SPLICE G T

SERIES1
SERIES2

For odd angle bends up to 30°

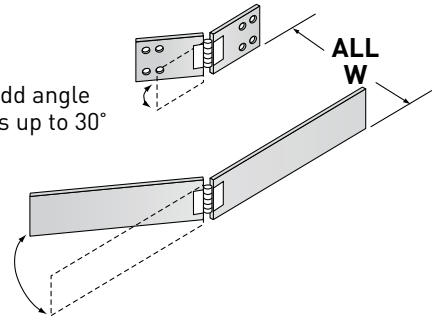

PRODUCT NUMBER	FASTENER OPTIONS
1305	GE S6
CATALOG NUMBERING EXAMPLE:	
Connector System No.	Fasteners
4 G 2 - 1305	- G E

VERTICAL ADJUSTABLE SPLICE G T

SERIES1
SERIES2

Maximum bend angle is ± 90

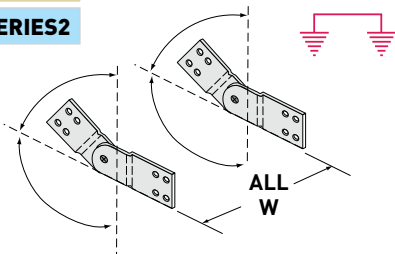

PRODUCT NUMBER	FASTENER OPTIONS
1307	GE S6
CATALOG NUMBERING EXAMPLE:	
Connector System No.	Fasteners
4 G 2 - 1307	- G E

VERTICAL HANGER SPLICE G T

SERIES1
SERIES2

APPLICATION

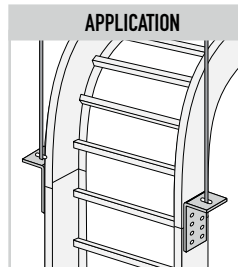
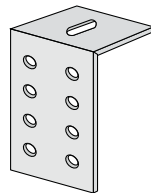

PRODUCT NUMBER	FASTENER OPTIONS
0356	GE S6
CATALOG NUMBERING EXAMPLE:	
Connector System No.	Fasteners
6 G 2 - 0356	- S 6

TRAY-TO-BOX FRAME CONNECTOR G T

SERIES1
SERIES2

Sold individually.

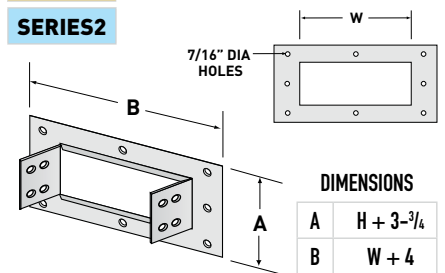

PRODUCT NUMBER	FASTENER OPTIONS
0403	GE S6
CATALOG NUMBERING EXAMPLE:	
Connector System No.	Width Fasteners
4 G 2 - 0403	- 12 - G E

All connectors on these pages are designed to fit Series 1 and 2 systems. When ordering, however, they should be specified as Series 2.



BONDING JUMPERS

Use across all discontinuities, expansion joints, and adjustable connectors to maintain electrical continuity in the cable tray system. Also use to bond the cable tray system to the building ground. Bonding jumpers are not required at standard or rigid splice locations. Fasteners for laminated bonding jumpers are included; fasteners for insulated jumpers must be ordered separately.

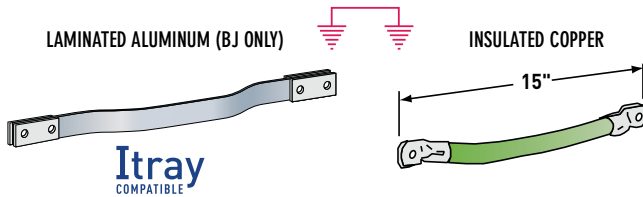

Laminated Aluminum: (4) 3/8" x 1/4" bolts per bonding jumper (included).

Insulated Copper: Made with flame-retardant, moisture- and heat-resistant, insulated copper cable. Tin plated copper lugs have one hole, sized for 3/8" x 3/4" bolt. Length is 15" to the center of the lug holes. Special lengths, lugs, and cables are also available.

LAMINATED ALUMINUM A		
PRODUCT NUMBER	L	RATED AMPS (N.E.C. 250-122)
BJ	21 1/4"	2000
CATALOG NUMBERING EXAMPLE (EA):		
Material		Fasteners
A - BJ		- 2000 - GE
INSULATED COPPER C		
PRODUCT NUMBER	COPPER CABLE SIZE	RATED AMPS (N.E.C. 250-122)
A806	#6	200
A807	#4	300
A804	#2	500
A803	#1	600
A808	1/0	800
A809	2/0	1000
A805	3/0	1200
A810	4/0	1600
A814*	4/0 WELDING CABLE 2107 STRANDS	1800
CATALOG NUMBERING EXAMPLE (EA):		
Material		
C - A806		

*Length is 30" to the center of the lug holes. One-hole tin-plated copper lugs are sized for 1/2" bolt. A814 is the only insulated copper bonding jumper that is compatible with Itray, as the other sizes are 15".

SPLICE FASTENERS



Knurled Bolt: Specially designed for cable tray connectors, the ribbed neck firmly grips the tray side rail to prevent screw rotation while tightening. Bolt can also be tightened with a Phillips screwdriver.



Flanged Hex Nut: "Free spinning" lock-type nut with a serrated face, eliminating the need for a washer. Nuts require a 9/16" wrench. Tighten to approximately 19-25 ft-lbs of torque.



Locking Hex Nut: For use with expansion connectors. Deformed threads cause this nut to lock on to the bolt after just a few turns, allowing movement of the bolt in the expansion slot without possibility of the nut backing off. Typically identified by a rectangular indentation on the side of the nut.



Flat Washer: For use with expansion connectors. Install under the locking hex nut in the expansion slots. Prevents binding in the expansion slot during movement of the tray due to thermal expansion.

DESCRIPTION	SIZE	COMPLETE CATALOG NUMBER	
KNURLED BOLT	3/8"-16 x 3/4"	DS-8530-01-GE	GE
		DS-8926-01-S6	S6
FLANGED HEX NUT	3/8" DIA.	DS-8524-01-GE	GE
		DS-8927-01-S6	S6
LOCKING HEX NUT	3/8" DIA.	DS-8575-02-GE	GE
		DS-8576-01-S6	S6
FLAT WASHER	3/8" DIA.	DS-8596-01-GE	GE
		DS-8600-01-S6	S6



RAIL HEIGHTS (H) INCHES

4 | 5 | 6 | 7

STRAIGHT HORIZONTAL DIVIDER A M T G*

For use with all straight tray. Furnished with four #10 self-drilling screws.

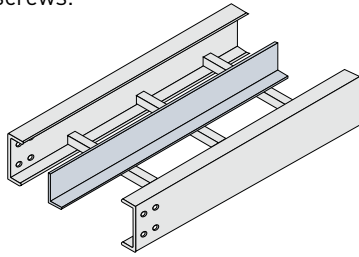

Itray
COMPATIBLE

PRODUCT NUMBER	L	FASTENER OPTIONS
0012-99	12	ZN S6
CATALOG NUMBERING EXAMPLE:		
Accessory System No.		Fasteners
4 A - 0012-99		- ZN

VERTICAL FITTING DIVIDER A M T G*

Furnished with two #10 self-drilling screws.

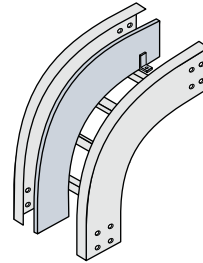

PRODUCT NUMBER	R	DIVIDER TYPE
9112-99	12	90° INSIDE ELBOW
9124-99	24	
9136-99	36	
9212-99	12	90° OUTSIDE ELBOW
9224-99	24	
9236-99	36	
6112-99	12	60° INSIDE ELBOW
6124-99	24	
6136-99	36	
6212-99	12	60° OUTSIDE ELBOW
6224-99	24	
6236-99	36	
4612-99	12	45° INSIDE ELBOW
4624-99	24	
4636-99	36	
4712-99	12	45° OUTSIDE ELBOW
4724-99	24	
4736-99	36	
3112-99	12	30° INSIDE ELBOW
3124-99	24	
3136-99	36	
3212-99	12	30° OUTSIDE ELBOW
3224-99	24	
3236-99	36	
FASTENER OPTIONS		ZN S6
CATALOG NUMBERING EXAMPLE:		
Accessory System No.		Fasteners
4 A - 9212-99		- ZN

FLEXIBLE HORIZONTAL DIVIDER A M T G*

For use with all horizontal fittings of any radius. Furnished with three #10 self-drilling screws.

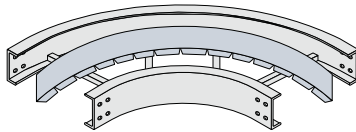

Itray
COMPATIBLE

PRODUCT NUMBER	L	FASTENER OPTIONS
0606-99	6'	ZN S6
CATALOG NUMBERING EXAMPLE:		
Accessory System No.		Fasteners
4 T - 0606-99		- S6

G* = optional

For detailed material and finish descriptions, see page B.6.



DIVIDER HOLD DOWN CLIP

M T G*

Purchased separately. Supplied with carriage bolt and flanged hex nut. Designed for use with ladders with box-shaped rungs (Types BX & BH—see pages B.66-B.67).

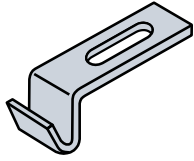

PRODUCT NUMBER	FASTENER OPTIONS
1852	ZN S6
CATALOG NUMBERING EXAMPLE:	
Material	Fasteners
M - 1852	- ZN

5" VINYL DIVIDER SPLICE

V

Splices joints of abutting divider strips. Vinyl edge strip is also available in bulk lengths.

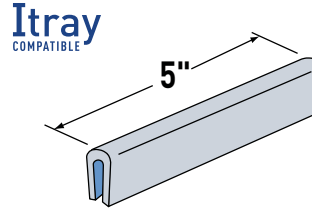

PRODUCT NUMBER
0930
CATALOG NUMBERING EXAMPLE:
Material
V - 0930

DIVIDER SPLICE

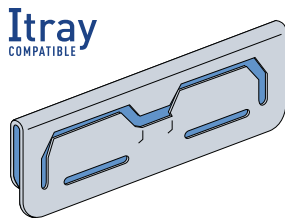

Sold in bags of 25.

	COMPLETE CAT. NO.
A	COTJ-AL
M	COTJ-PG
T	COTJ-316

SELF-DRILLING SCREW



Provided with all dividers, but extras can be ordered separately.

COMPLETE CATALOG NO.		SIZE
DS-8930-01-ZN	ZN	#10 X 3/4"
DS-8930-01-S6	S6	#10 X 3/4"



BLIND END PLATE

M T G*

Seals off the open end of a cable tray. Attaches to the tray using standard 3/8" dia. connector fasteners.

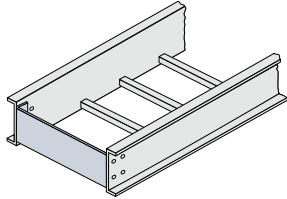

PRODUCT NUMBER	FASTENER OPTIONS
0402	GE S6
CATALOG NUMBERING EXAMPLE:	
Height/Material	Width Fasteners
4 T - 0402 - 12 - GE	

CABLE DROPOUT

A M T G*

Provides a smooth, rounded surface for cables dropping out of the bottom of the cable tray.

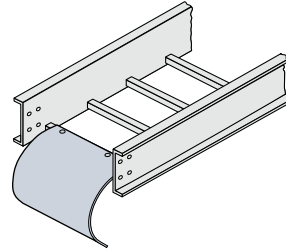

PRODUCT NUMBER	R
0253	3/4
0254	5
FASTENER OPTIONS	ZN S6
CATALOG NUMBERING EXAMPLE:	
Material-Flange	Width Fasteners
A1 - 0253 - 06 - S6	

TRAY WIDTH (NOMINAL)	6	9	12	18	24	30	36	
DROPOUT WIDTH (FLG IN)	2 1/4	5 1/4	8 1/4	14 1/4	20 1/4	26 1/4	32 1/4	IN
DROPOUT WIDTH (FLG OUT)	5 1/4	8 1/4	11 3/4	17 3/4	23 3/4	29 3/4	35 3/4	

WALL PENETRATION SLEEVE

M G T

Provides a rigid support for cable tray at wall penetrations. Overall length of the sleeve is 20". Will fit walls up to 8" thick. Bonding jumpers are not required for use with wall sleeves. Two pairs of splice plates and fasteners are included for tray attachment.

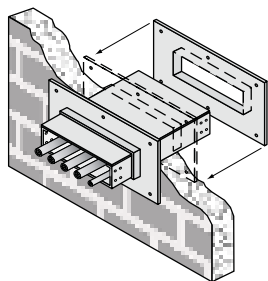

PRODUCT NUMBER	FASTENER OPTIONS
0424	GE S6
CATALOG NUMBERING EXAMPLE:	
Connector System No	Width Fasteners
4 T 2 - 0424 - 12 - S6	

OUTDOOR CONVERSION FOR WALL PENETRATION

G T

Makes ladder tray wall penetrations weather resistant to minimize water intrusions. Removable cover/shield fastens to tray and wall penetration sleeve for the utmost in weather protection.

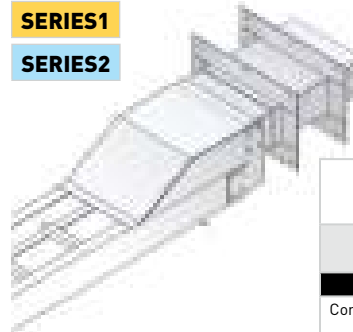

- Fits Standard Hot-Dip Galvanized or Stainless "0424" or "0440" wall penetrations (see page B.58.)
- Sized to fit flange-in or flange-out trays

PRODUCT NUMBER	FASTENER OPTIONS
0434	GE S6
CATALOG NUMBERING EXAMPLE:	
Connector System No	Width Fasteners
4 G 2 - 0434 - 06 - GE	

The wall penetration sleeve and outdoor conversion kit are designed to fit Series 1 and 2 systems. When ordering, however, they should be specified as Series 2.

G* = optional

For detailed material and finish descriptions, see page B.6.

WWW.LEGRAND.US/CABLOFIL



HOLD DOWN/EXPANSION CLAMP

A Z T

Works as an expansion guide and flips over for use as a hold down clamp for use with all ladder trays. Sold in packs of 10.

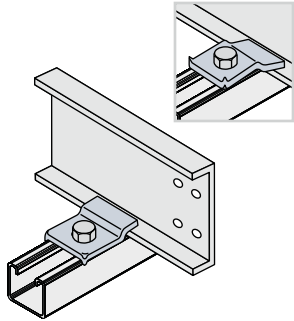

Itray
COMPATIBLE

PRODUCT NUMBER	FASTENER OPTIONS
1893-01*	ZN S6
1893-02	NONE
1893-03†	ZN S6

CATALOG NUMBERING EXAMPLE:
Material Fasteners
A - **1893-01** - ZN

* Includes 3/8" x 1 1/2" hex bolt, 3/8" flanged nut.

† Includes 3/8" x 1 1/2" hex bolt, 3/8" spring nut.

Z-HOLD DOWN/EXPANSION GUIDE

M T G

Wraps around the tray side rail for use with all solid bottom trays. Can also be used with any flange-in tray system. Expansion guide is slightly taller to permit longitudinal tray movement caused by thermal expansion. Sold individually.

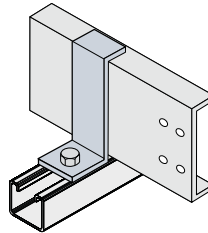

PRODUCT NUMBER		FASTENER OPTIONS
Z-HOLD DOWN	EXPANSION	
1866-01*	1867-01	ZN S6
1866-02	1867-02	NONE
1866-03†	1867-03	ZN S6

CATALOG NUMBERING EXAMPLE:
Accessory System No. Fasteners
4 M - **1866-01** - ZN

* Includes 1/4" x 3/4" carriage bolt, 1/4" flanged nut.

† Includes 1/4" x 1 1/2" screw, 1/4" spring nut.

HEAVY-DUTY HOLD DOWN BRACKETS

A G T

Designed for use with all trays. 3/8" diameter hardware for tray attachment only is included. Holes for structure attachment are sized for 1/2" diameter fasteners. Ideal for vertical tray support. Sold in pairs.



PRODUCT NUMBER	FASTENER OPTIONS
A845	GE S6

CATALOG NUMBERING EXAMPLE:
Material Fasteners
T - **A845** - S6

Itray
COMPATIBLE

WIRE MESH-TO-LADDER CLAMP

Z T

This unique clamp allows wire mesh cable tray to be attached to the side rails of any ladder tray and a pre-installed setscrew secures the junction for a permanent installation.

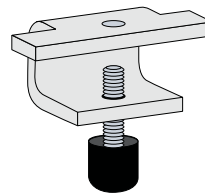

Itray
COMPATIBLE

PRODUCT NUMBER	FASTENER OPTIONS
WMC 2LA	GE S6

CATALOG NUMBERING EXAMPLE:
Material Fasteners
T - **WMC 2LA** - S6

METALLIC ACCESSORIES

WIDTHS (W) INCHES
6 | 9 | 12 | 18 | 24 | 30 | 36

RAIL HEIGHTS (H) INCHES
4 | 5 | 6 | 7

SPICES Match above to determine the connectors you need.



SERIES1

Fitting side rails have 2" tangents (flat portion beyond curvature) at the end of each fitting, to accommodate splice plates with four holes.

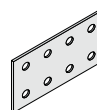

SERIES2

Fitting side rails have 5" tangents at the end of each fitting, to accommodate splice plates with eight holes.



I-BEAM HOLD DOWN CLAMP/ EXPANSION GUIDE

Z T

Hold Down Clamp firmly attaches the cable tray to the flange of an I-beam type support.

Expansion Guide attaches the clamp to the flange of an I-beam type support, allowing movement of the tray side rail due to thermal contraction and expansion.

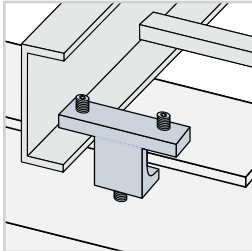

Itray
COMPATIBLE

PRODUCT NUMBER		FASTENER OPTIONS
HOLD DOWN	EXPANSION	
A802-01*	A802-02†	GE S6
CATALOG NUMBERING EXAMPLE:		
Accessory System No.		Fasteners
Z - A802-01 - S6		

*Includes (2) 1/2" x 5/8" screws and (1) 1/2" x 1 1/2" screw.

†Includes (1) 1/2" x 1 1/2" screw.

No drilling is required for either installation.

SINGLE OVERHEAD HANGER CLAMP

M

Attaches to the tray bottom flange and supports the cable tray directly from a threaded rod without the need for an additional support member. Threaded rod purchased separately.

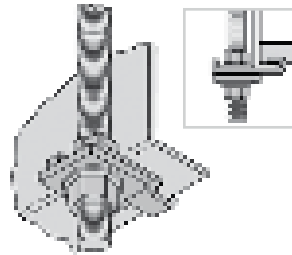

SERIES1

PRODUCT NUMBER	ROD DIA.	FASTENERS INCLUDED
1899-01	1/2"	ZN S6
1899-02	3/8"	
CATALOG NUMBERING EXAMPLE:		
Material		Fasteners
M - 1899-01 - S6		

HANGER BRACKETS

M T G*

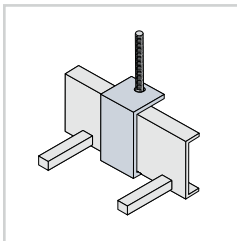

SINGLE: Supports a single tray side rail from a 1/2" threaded rod. For use with all flange-out ladder tray systems. Safe load = 300 lbs. per bracket.

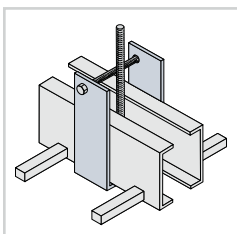

DOUBLE: Supports two tray side rails that are installed side-by-side from a single 1/2" threaded rod. For use with all flange-out ladder tray systems. Safe load = 300 lbs. per bracket.

PRODUCT NUMBER		FASTENER OPTIONS
SINGLE	A836	
DOUBLE	A837*	ZN S6
CATALOG NUMBERING EXAMPLE:		
Accessory System No.		Fasteners
4 M 2 - A837 - ZN		

*Includes 1/4" x 5" hex head bolt and 1/4" flanged nut.

NYLON ISOLATION PAD

N

Made of extruded black nylon. Can be installed between the cable tray and support member to provide electrical isolation of the tray system. Can also be used to facilitate cable tray movement caused by thermal contraction and expansion. No fasteners required.

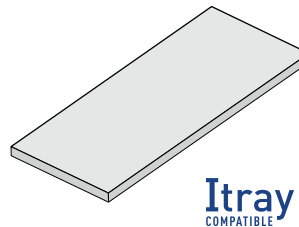

Itray
COMPATIBLE

PRODUCT NUMBER	DIMENSIONS
8945	1/8" X 3" X 6"
CATALOG NUMBERING EXAMPLE:	
Material	
N - 8945	

G* = optional



SINGLE HANGER CHANNEL

A M G T

Made from 12-gage strut. Hangers have 9/16" diameter holes 13/16" from each end to accept 1/2" threaded rod. Kit includes fasteners. When used with Z-type hold-down clamps, select hanger with flange out dimensions.

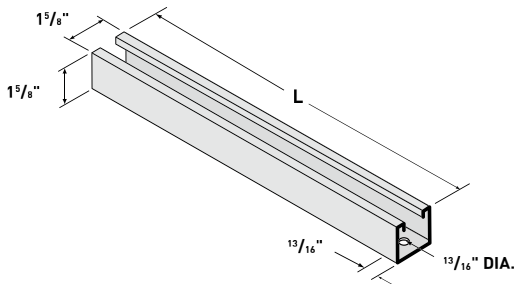

SINGLE HANGER CHANNEL KIT*

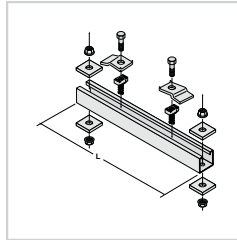

TRAY WIDTH	PRODUCT NUMBER		FLANGE IN	FLANGE OUT Itray COMPATIBLE
	HANGER	KIT	L (W+4)	L (W+10)
6	0373	0393	10	16
9			13	19
12			16	22
18			22	28
24			28	34
30			34	40
36			40	46
FASTENERS INCLUDED WITH KIT ONLY*				ZN S6
CATALOG NUMBERING EXAMPLE: Material Length Fasteners M - 0393-10 - S6*				

DOUBLE HANGER CHANNEL

A M G T

Made from 12-gage struts welded back-to-back. Hangers have 9/16" dia. holes 13/16" from each end to accept 1/2" threaded rod. When used with Z-type hold-down clamps, select hanger with flange out dimensions.

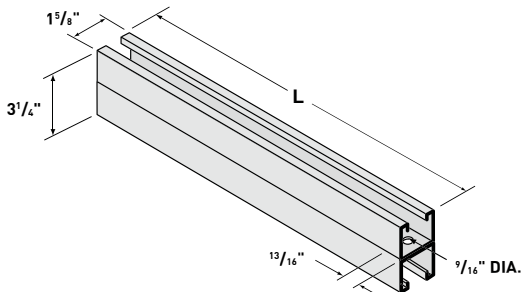

DOUBLE HANGER CHANNEL KIT*

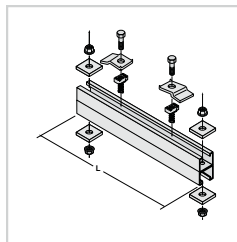

TRAY WIDTH	PRODUCT NUMBER		FLANGE IN	FLANGE OUT Itray COMPATIBLE
	HANGER	KIT	L (W+4)	L (W+10)
6	0371	0394	10	16
9			13	19
12			16	22
18			22	28
24			28	34
30			34	40
36			40	46
FASTENERS INCLUDED WITH KIT ONLY*				ZN S6
CATALOG NUMBERING EXAMPLE: Material Length Fasteners M - 0394-16 - S6*				

CENTER HANGER CHANNEL

M G T

Mounts with one 1/2" threaded rod to allow cable installation from both sides. Cable should be loaded evenly on both sides of the center support to remain level. 12-gage strut accepts channel nuts for hold down clamps with no drilling required. Not recommended for trays over 24" wide. When used with Z-type hold-down clamps, select hanger with flange out dimensions.

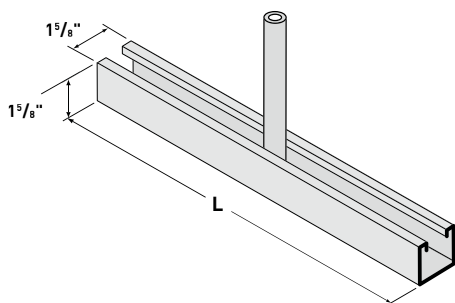

CENTER HANGER CHANNEL KIT*

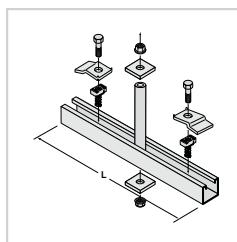

TRAY WIDTH	PRODUCT NUMBER		FLANGE IN	FLANGE OUT Itray COMPATIBLE
	HANGER	KIT	L (W+2)	L (W+6)
6	0369	0395	8	12
9			11	15
12			14	18
18			20	24
24			26	30
FASTENERS INCLUDED WITH KIT ONLY*				ZN S6
CATALOG NUMBERING EXAMPLE: Material Length Fasteners M - 0395-10 - S6*				

*Kits include hardware for ladder trays. Contact Legrand for other design options.

WALL BRACKET G T

Recommended for use with flange-in cable trays.

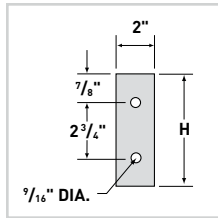
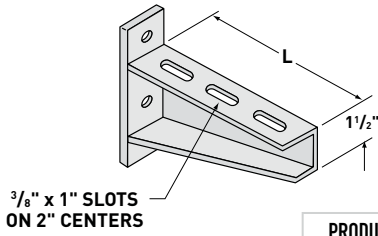

PRODUCT NUMBER	L	H	DESIGN LOAD - UNIFORM (LBS.)
0353	7	6	900
	10	6	
	13	6	
	19	7 $\frac{1}{2}$	
	25	7 $\frac{1}{2}$	
CATALOG NUMBERING EXAMPLE: Material Length G - 0353 - 13			

SINGLE STRUT BRACKET G T

Made with 1 $\frac{5}{8}$ " x 1 $\frac{5}{8}$ " x 12 gage steel struts.

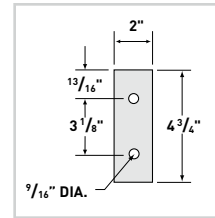
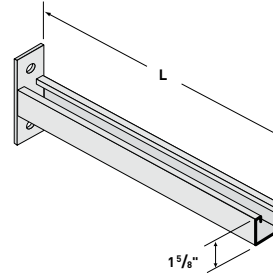

PRODUCT NUMBER	L	DESIGN LOAD - UNIFORM (LBS.)
0215	7	1000
	10	720
	13	550
	16	450
	19	380
	22	320
25	290	
CATALOG NUMBERING EXAMPLE: Material Length G - 0215 - 13		

Itray
COMPATIBLE

DOUBLE STRUT BRACKET G T

Made with 1 $\frac{5}{8}$ " x 1 $\frac{5}{8}$ " x 12 gage steel struts.

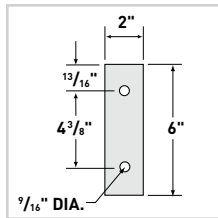
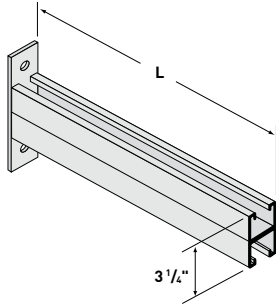

PRODUCT NUMBER	L	DESIGN LOAD - UNIFORM (LBS.)
0216	7	3000
	10	2400
	13	1850
	16	1500
	19	1250
	22	1100
	25	960
	31	770
	43	560
CATALOG NUMBERING EXAMPLE: Material Length T - 0216 - 13		

Itray
COMPATIBLE

HEAVY-DUTY STRUT BRACKET G T

Made with 1 $\frac{5}{8}$ " x 1 $\frac{5}{8}$ " x 12 gage steel struts.

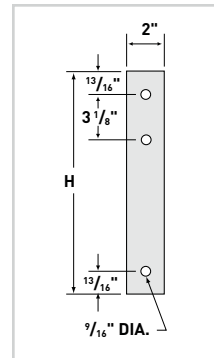
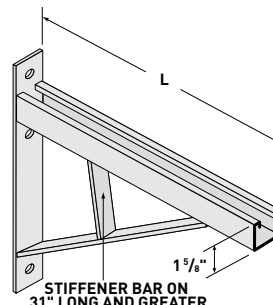

PRODUCT NUMBER	L	H	DESIGN LOAD - UNIFORM (LBS.)
0392	13	10	1600
	19	15	1200
	25	18	900
	31	22	750
	37	25	675
	43	29	580
	49	32	500
CATALOG NUMBERING EXAMPLE: Material Length G - 0392 - 13			

Itray
COMPATIBLE



CABLE CLAMP

T

For use with all ladder cable trays with box-shaped rungs.

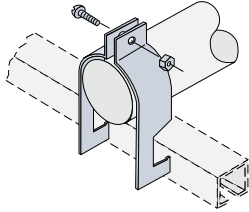

PRODUCT NUMBER	CABLE SIZE
1916-06	3/4"
1916-07	7/8"
1916-08	1"
1916-09	1 1/8"
1916-10	1 1/4"
1916-11	1 3/8"
1916-12	1 1/2"
1916-13	1 5/8"
1916-14	1 3/4"
1916-15	1 7/8"
1916-16	2"
1916-17	2 1/8"
1916-18	2 1/4"
1916-19	2 3/8"
1916-20	2 1/2"
1916-21	2 5/8"
1916-22	2 3/4"
1916-23	2 7/8"
1916-24	3"
1916-25	3 1/8"
1916-26	3 1/4"
1916-27	3 3/8"
1916-28	3 1/2"
1916-29	3 5/8"
1916-30	3 3/4"
1916-31	3 7/8"
1916-32	4"

FASTENERS INCLUDED	S6
CATALOG NUMBERING EXAMPLE:	
Material	Fasteners
T - 1916-06	- S6

GROUND WIRE ATTACHMENT CLAMP

Z T

Holds one or two bare copper or aluminum ground wires against the cable tray side rail using included 3/8" diameter fasteners. This clamp does not bond the ground wire to the tray.

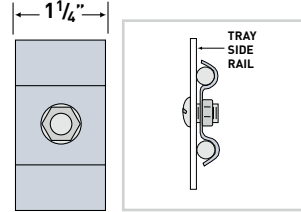

Itray
COMPATIBLE

PROD. NO.	CONDUCTOR SIZE
1873-02	#2, #1 AND 1/0
1873-03	#6 TO #4
1873-04	2/0, 3/0 AND 4/0

FASTENER OPTIONS	GE S6
CATALOG NUMBERING EXAMPLE:	
Material	Fasteners
Z - 1873-02	- S6

CONDUIT BRACKET CLAMP

Z T

Attaches conduit to the cable tray side rail.

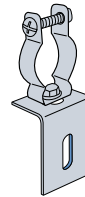

APPLICATION

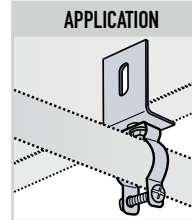

Itray
COMPATIBLE

PROD. NO.	CONDUIT DIA.	EMT DIA.
0228-05	3/8" - 1/2"	1/2"
0228-06	3/4"	3/4"
0228-10	1"	1"
0228-11	1 1/4"	1 1/4"
0228-12	1 1/2"	1 1/2"
0228-20	2"	2"
0228-25	2 1/2"	2 1/2"
0228-30	3"	3"
0228-40	4"	4"

FASTENER OPTIONS	ZN S4
CATALOG NUMBERING EXAMPLE:	
Material	Fasteners
T - 0228-05	- S4

CABLE TRAY GROUNDING CLAMP

A

Provides an excellent ground for copper or aluminum ground wires to the cable tray. A 1/4" hex wrench is used to tighten both tray and conductor set screws. Clamps are tin-plated, extruded aluminum. Conductor Range: #6AWG to 250 MCM.

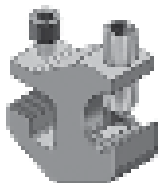

PRODUCT NUMBER	FASTENERS INCLUDED
A840-01	ZN

CATALOG NUMBERING EXAMPLE:	
Material	Fasteners
A - A840-01	- ZN

CONDUIT PLATE CLAMP

A M

Attaches conduit to the ladder tray rungs.

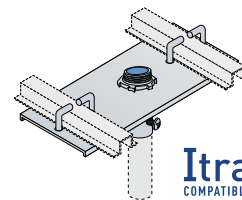

Itray
COMPATIBLE

RUNG SPACING INCHES

9" PLATE | 6 9

18" PLATE | 12 18

*Can also be used with medium-wall (IMC) and thick-wall (rigid) conduit.

PRODUCT NUMBER	EMT DIA.
0226-05	1/2"
0226-06	3/4"
0226-10	1"
0226-11	1 1/4"
0226-12	1 1/2"
0226-20	2"
0226-25*	2 1/2"
0226-30*	3"
0226-40*	4"

FASTENERS INCLUDED	GE	
CATALOG NUMBERING EXAMPLE:		
Rung Spacing	Material	Fasteners
09	- M	- 0226-11 - GE

CLAMP BRACKET

M T

Permits attachment of clamps or other components to the cable tray side rail. Conduit clamps are purchased separately.

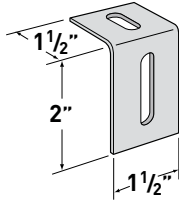

PRODUCT NUMBER	FASTENER OPTIONS
1818	ZN S6
CATALOG NUMBERING EXAMPLE:	
Material	Fasteners
T - 1818 - S6	

MAPLE CABLE BLOCKS

Paraffin impregnated and furnished with 1/4" dia. fasteners. Contact Legrand with quantities, cable dimensions, cable spacing, and cable tray system information. Can be custom designed for a wide variety of applications.

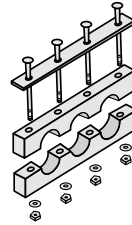

PRODUCT NUMBER	FASTENERS INCLUDED
0950	AS SPECIFIED

SLIP-ON LOCK NUT®

ZN S4

Allows the user to slip the nut onto a rod, without actually threading it. Ideal for when nuts must be added to a rod, but cannot be threaded due to previously-installed equipment.

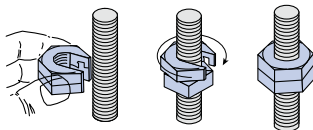

PRODUCT NUMBER	SIZE
SON 1/4	1/4"-20
SON 3/8	3/8"-16
SON 1/2	1/2"-13
CATALOG NUMBERING EXAMPLE:	
Fasteners	
SON 3/8 - Z N	

PLASTIC SAFETY SIGN



Sign measures 8"x12".

COMPLETE CATALOG NUMBER
P-0949-01

Itray
COMPATIBLE



FIRE WALL PENETRATION SLEEVE

M G T

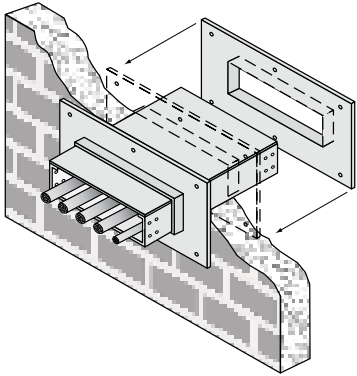

- Wall Penetration Sleeve (WPS or FWPS) not included in kit, must be ordered separately

PRODUCT NUMBER	FASTENER OPTIONS
0440	GE S6

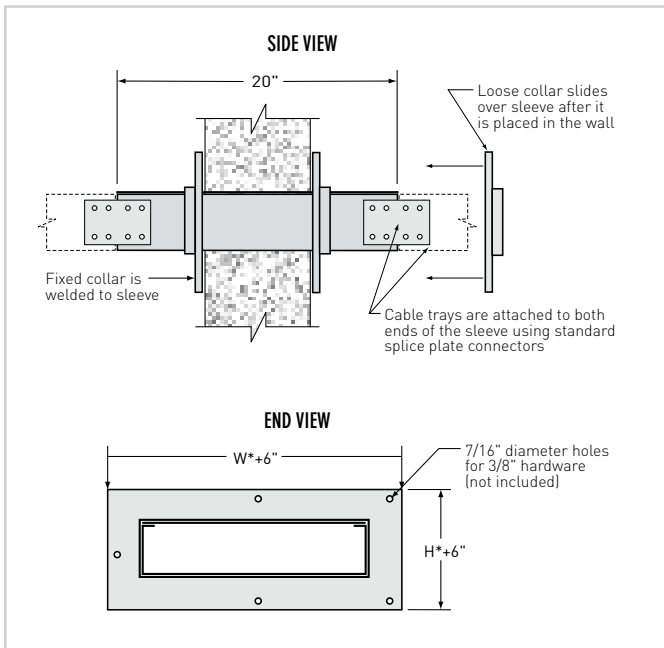

Fabricated cable tray fire stop sleeves from Legrand, combined with Hilti Firestop products, are an economical alternative to the high cost of fabricating protective fire wall and floor penetration sleeves in the field.

This firestop system provides a rigid support for cable tray in a UL classified system approved for fire wall and floor penetrations. After the sleeve is placed in the wall or floor, the loose collar slides over it. Hardware for the tray connection only is included. Hardware required to mount sleeves to the wall or floor is not included.

The Hilti Fire Block is a compressible fire stop brick, well-suited for installations where frequent cable changes may be required. Blocks are easily cut to fit any space, and can be removed and reinstalled when cable configurations change. When exposed to fire, the blocks expand to lock the seal in place.

Each cable tray firestop sleeve includes:

- One penetration sleeve with flanges
- Hilti Fire Blocks
- One Hilti Firestop Putty Stick
- Hardware for cable tray connection to the wall sleeve:

- Metallic and fiberglass cable trays with two side rails. The Firestop kit includes two pairs of splice plates with nuts & bolts; 316 stainless steel is recommended for use with fiberglass systems.

NUMBER OF HILTI FIRE BLOCKS INCLUDED WITH EACH SLEEVE

SLEEVE WIDTH	SIDE RAIL HEIGHT (IN.)			
	4	5	6	7
6	2	2	3	3
9	3	3	4	4
12	3	4	5	6
18	5	6	7	8
24	6	8	9	11
30	8	10	12	14
36	9	12	14	16

OUTDOOR CONVERSION FOR WALL PENETRATION (0434)
See page 51.

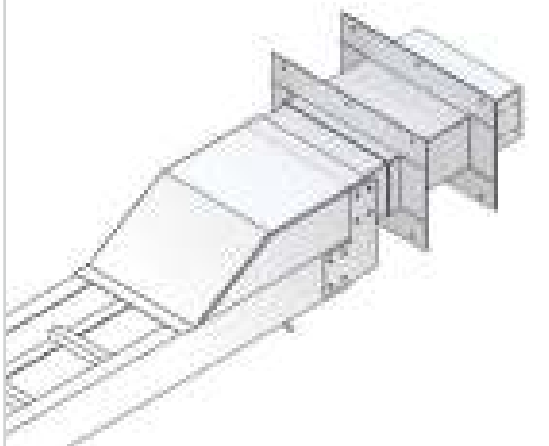

UL classified for use with:

- 2-hr concrete or block walls
- 2-hr concrete floors
- 1-hr gypsum walls
- 2-hr gypsum walls



Floor Firestop Sleeve Example
 0440 product used as a floor sleeve per UL assembly
 W-L-3226 and C-AJ-3232

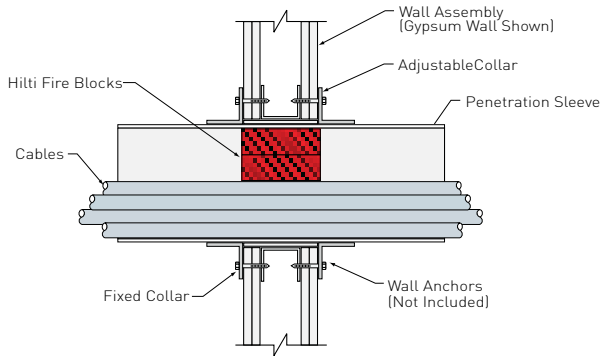

Floor Firestop Sleeve Example
 0440 product used as a floor sleeve per UL assembly
 F-A-3022

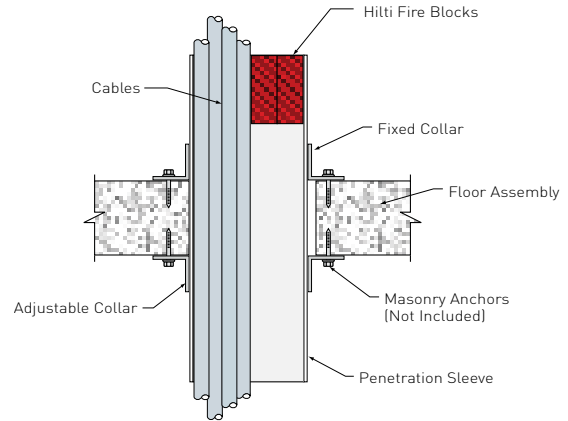

WALL/FLOOR SLEEVE DESCRIPTION

Designed for single runs of cable tray, having a height and width to match the tray system specified. One end of the 20 inch sleeve has a flange attached 6 inches from the end, while the flange for the other end is “floating” and is free to slide directly against the face of the wall as needed. The 20 inch length of the sleeve will accommodate a wall thickness of up to 8 inches. A wall thickness of 8 inches will result in the sleeve protruding 6 inches from each side of the wall. Both ends of the sleeve are punched with holes for attaching cable tray splice plates or hardware needed for the tray system specified.

INSTALLATION

The opening in the wall should be within 1 inch of the nominal height and width of the cable tray. The flanges of the sleeve have 7/16" diameter mounting holes for attachment to the wall using 3/8" diameter hardware. Hardware for wall attachment is not included. After the sleeve is mounted in the wall or floor, the cable trays on either side of the sleeve can be connected using the hardware supplied with the sleeve. When the trays are in place, the cables should be pulled through the wall and sleeve as needed. After all of the cables are installed in the tray, install the Fire Blocks as described. Any voids between cables should be filled with the Firestop Putty Stick.

TECHNICAL DATA

- Construction Arc Welded
- Sleeve Dimensions 20" x Tray Width x Tray Height
- Flange Dimensions (Tray Width + 6") x (Tray Height + 6")
- UL Classification Qualifies for use as an equipment grounding conductor per N.E.C. 392.7. Cross-sectional area and amperage ratings are based on the cable tray system attached to the sleeve.

HILTI FIRE BLOCKS INSTALLATION

- Walls:** Hilti Fire Blocks shall be installed with 5" dimension projecting through and centered within wall assembly.
- Floors:** Hilti Fire Blocks shall be installed with 5" dimension projecting through opening, flush with the top surface of sleeve or recessed within sleeve at any level above the top surface of floor.

Fire blocks fill the annular space between the cables and the sleeve. Fire Blocks may be cut to match the profile of cables or to fit opening. Any voids should be filled with 0618 Firestop Putty Stick.

WALL PENETRATION SLEEVE CATALOG NUMBERING EXAMPLE:

CONNECTOR SYSTEM NO.		PRODUCT NO.		FASTENER OPTIONS	
6	M	2-0440	-36-		GE
SIDE RAIL HEIGHT	4 - 4"	MATERIAL	FITTING SERIES This item must be specified as SERIES 2	WIDTH	GE
	5 - 5"				S6
	6 - 6"				
	7 - 7"				



METALS

PW from Legrand, a pioneer in the development of cable trays, first made a complete study of the metals available in order to create those systems that would be unmatched in economy and strength. Inherent are the problems connected with the environment and its effect on the life of metals, including weathering and corrosion by electro-chemical and chemical attack.

Steel – Hot-Dip Galvanized After All Fabrication and Welding

Commercial quality steel is used for this type of coating, which is described below. This steel is either hot rolled, pickled and oiled, or cold rolled, mild carbon steel.

Steel – Mill Galvanized (Pre-Galvanized)

Where heavy zinc coating is not necessary, steel with a continuous hot rolled zinc coating conforming to ASTM specification A653 designation G90 is used. Products made with mill galvanized steel are generally lower in cost than the same products that are hot dip galvanized after fabrication. However, see the limitations under “Finishes” later on this page.

Stainless Steel

18-8 stainless steel type 304 and marine-grade type 316 is available for most PW products. Certain products such as raceway push clips, Stack-A-Tube yoke clamps, and some hardware items are made only from 18-8 stainless steel. Stainless steel components are compatible for use with hot dip galvanized, mill galvanized, and aluminum products. Complete cable tray systems can be furnished in stainless steel.

Aluminum Alloys

The principal aluminum used for tray side rails, rungs, and channels is extruded, copper-free alloy 6063-T6. This alloy is used for structural members where extreme stiffness and high tensile strength are mechanically required to resist high unit stresses. This is called a “magnesium alloy”.

Alloy 5052-H32 is used for components fabricated from sheet (except covers) such as connectors, blind ends, dropouts, etc. This is a “magnesium alloy”, copper free, and very compatible with alloy 6063-T6. This alloy possesses excellent characteristics for stamped and formed components.

Alloys 3003 and 3105 are used for aluminum covers. These alloys are very compatible with alloys 6063-T6 and 5052-H32.

FINISHES

Steel – Hot-Dip Galvanized After All Fabrication and Welding:

This high-quality coating is created in a multi-step process and applied to the completed product after all fabrication and welding. First the steel is cleaned by immersing it in a caustic dip tank, then pickled, and finally washed. The article is then dipped into a molten zinc bath. All surfaces are thoroughly coated. Hot dip galvanizing after all fabrication and welding is done on PW products in accordance with ASTM Specification A123. This coating, applied to steel trays, provides greatest protection at lower cost.

Due to the high temperatures associated with the hot dip process, some warping of the metal is common. This occurs most frequently with products having large, flat surfaces such as covers. To minimize warping, PW uses thicker sheet metal for covers. This does reduce warping, but does not eliminate it.

Mill Galvanized (Pre-Galvanized)

This coating is applied onto steel sheets at the mill in accordance with ASTM Specification A653 and results in a coating thickness of 0.90 ounces per square foot total for both sides. This coating adheres tightly to the base metal at bends and compound curves. Being a hot dip coating prior to tray fabrication, and of a controlled thickness about one-third that of hot dip galvanized after fabrication, it is not generally used outdoors. It is not recommended for areas where there is a concentration of moisture and/or chemical deposits. This material gives excellent service in dry, normal, or controlled atmospheres.

Some Helpful Hints On Which Zinc Coating To Select

1. Protection of the base metal is directly proportional to the zinc coating thickness. Hence, thicker coating means longer life. At sheared or punched locations, zinc on mill galvanized steel is wiped down over approximately $\frac{1}{3}$ of the metal thickness giving some sacrificial protection in the presence of an electrolyte. On hot dip galvanized after fabrication, all edges are coated but the original cost is higher.
2. The edges of holes in mill galvanized steel will have no coating; however, a small sacrificial protection is afforded by the top and bottom surfaces of the sheet. The hot dip galvanized comment above applies here.
3. If moisture and drippings accumulate, consider hot dip galvanized after fabrication to avoid premature deterioration at those locations.
4. Covers are typically made from mill galvanized steel in order to avoid the poor appearance caused by severe warping of such large flat surfaces when hot dip galvanized after fabrication.

Other Coatings

Occasionally, other highly special coatings are required such as powder coating, epoxy painting, standard painting, primer paint, and others. Legrand engineers are available for consultation on these coatings and their application to PW trays.



THERMAL CONTRACTION AND EXPANSION

Expansion Splice Plate Installation

It is important that thermal contraction and expansion be considered when installing cable tray systems. The length of the straight cable trays runs and the temperature differential govern the number of expansion splice plates required (see Table 1).

Proper operation of the expansion splice plates depends upon correct placement of the tray supports, hold down clamps and expansion guides as shown.

Hold Down Clamps should be used at the support point nearest to the midpoint between expansion gaps.

Expansion Guide Clamps should be used at all support points other than the midpoint. These clamps should be installed in such a way to allow the tray to slide freely under the clamp when thermal contraction and expansion takes place.

Supports with expansion guide clamps should be located within 24" of each side of expansion splice plates.

Accurate gap settings between trays at the expansion joint at the time of installation are necessary for the proper operation of the expansion splice plates. Use the following procedure to determine the correct gap setting:

- A** Determine what the maximum temperature will be at the installation location and plot this point on the graph on the max. temp line. (Example value = 100)
- B** Determine what the minimum temperature will be at the installation location and plot this point on the graph on the min. temp line. (Example value = -30).
- C** Draw a line between the maximum and minimum points.
- D** At the time of installation, determine the air temperature. (Example = 50). Plot this point on the line drawn between the maximum and minimum temperatures to determine the correct gap setting at the expansion plate. (Example = 3/8").

Table 1

TEMPERATURE DIFFERENTIAL		MAXIMUM SPACING BETWEEN EXPANSION JOINTS FOR 1" MOVEMENT (FT.)					
°F	°C	A	M	G	L	T	F
25	14	260					667
50	28	130					333
75	42	87					222
100	56	65					167
125	70	52					133
150	83	43					111
175	97	37					95

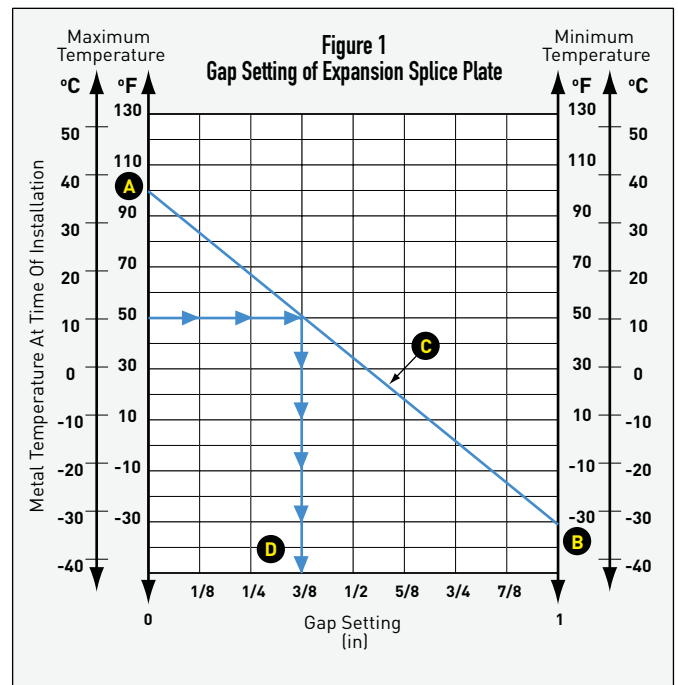

Expansion splice plates should be placed on the outside of the cable tray on both side rails. The screw heads should be on the inside and nuts on the outside of the cable tray. Tighten the lock nuts on the screws in the slotted holes just a few turns, allowing the bolt to move freely in the slot.

Figure 2
Expansion Connector Installation Locations

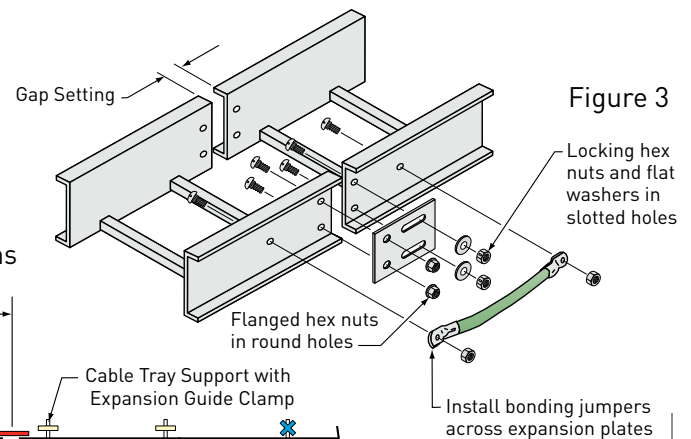
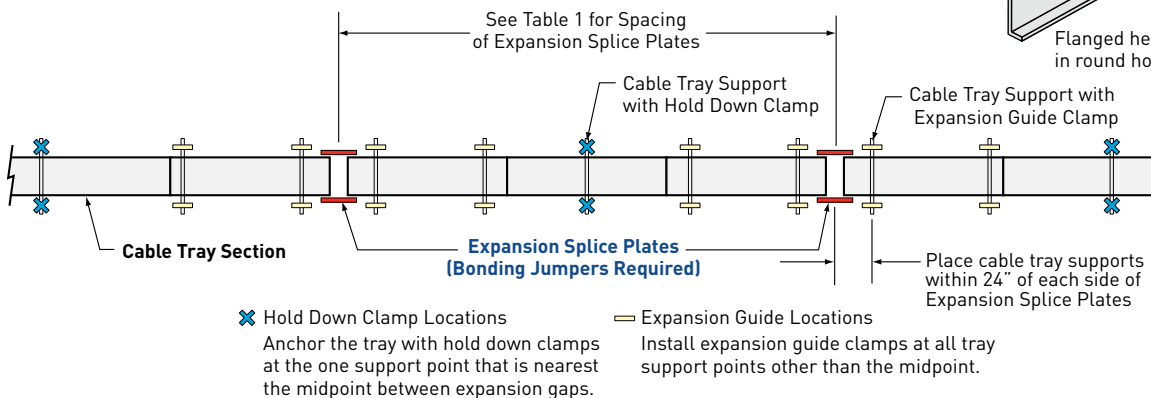
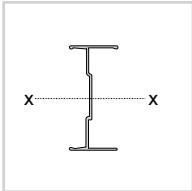
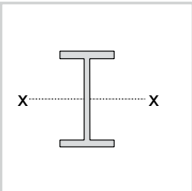

Figure 3



CABLE TRAY SIDE RAILS

The mechanical properties of cable tray side rails for straight tray sections are shown for all standard systems. Side rails used for fittings may have slightly different dimensions since they must be suitable for bending into curved sections. Fitting side rails are designed to meet or exceed the loading requirements of the straight tray sections with which they are used when supported per NEMA VE2 installation guidelines. Although the cross-sectional dimensions of the fitting side rails may be slightly different than the straight section side rails, all aspects of fitting design are in accordance with NEMA VE1 requirements. Please contact Legrand for detailed information on fitting side rails.

 ITRAY I-BEAM A				
RAIL HEIGHT (IN.)	NEMA CLASS	PRODUCT NUMBER	I_x MOMENT OF INERTIA (IN. ⁴)	S_x SECTION MODULUS (IN. ³)
4	12B	4A12B	1.343	0.626
	12C	4A12C	1.418	0.646
	20B	4A20B	2.717	1.103
5	12C	5A12C	2.288	0.859
	20B	5A20B	3.344	1.146
6	12C	6A12C	3.993	1.182
	20B	6A20B	5.441	1.549
	20C	6A20C	6.380	1.836
	24C	6A24C	8.128	2.349
7	12C	7A12C	5.403	1.106
	20B	7A20B	7.675	1.896
	20C	7A20C	9.803	2.471
	24C	7A24C	12.092	3.005
 I-BEAM A				
8	20C+	S2	25.8053	7.1067
			26.3140	7.3722
10			70.3837	15.2789

 C-CHANNEL G				
RAIL HEIGHT	NEMA CLASS	SERIES	I_x MOMENT OF INERTIA (IN. ⁴)	S_x SECTION MODULUS (IN. ³)
4	12B	S1	0.6214	0.3517
	12C, 16A		0.7417	0.4110
	20A, 16B	S2	1.0593	0.5860
	20B, 16C		1.3781	0.7984
	20C		1.7934	1.0044
5	12B	S1	1.0785	0.4796
	12C, 16A		1.2925	0.5645
	20B, 16C	S2	2.3334	1.0632
	20C		3.1670	1.4398
6	12B	S1	1.7047	0.6234
	12C, 16A		1.7873	0.6733
	20B, 16C	S2	2.7718	1.0001
	20C		3.4185	1.2324
7	12B	S1	2.5243	0.7830
	12C, 16A		2.6403	0.8411
	20B, 16C	S2	4.0298	1.2366
	20C		4.9763	1.5260
 I-BEAM G				
8"	20C+	S2	18.5	4.62
			30.8	7.81
10"			68.9	13.8



RUNG DESIGNS

PW offers a wide range of rung design options for special load applications. Extremely heavy cable loads, concentrated static loads, and heavy snow or ice loads may require rungs with greater load capacities than standard designs. Rung substitutions are designated by suffixes added to the tray catalog numbers.

STANDARD RUNGS AND BOTTOMS - ALUMINUM A		
TYPE		USE
AL		I-BEAM RUNG, 1" DEEP STANDARD FOR MOST LADDERS UP TO 24" WIDE
AH		HEAVY I-BEAM RUNG, 1" DEEP STANDARD FOR MOST LADDERS 30" AND WIDER
SR		SLOTTED STRUT RUNG, 1 5/8" DEEP STANDARD FOR LONG-SPAN LADDER TRAY WITH SIDERAIL OF 8" OR LARGER
CA		CORRUGATED SHEET BOTTOM SOLID TROUGH
UPGRADE RUNG - ALUMINUM A		
ST		SLOTTED STRUT RUNG, 1" DEEP UPGRADE OPTION FOR LADDERS SEE BELOW FOR SLOT DETAIL

STANDARD RUNGS AND BOTTOMS - STEEL M G L T		
TYPE		USE
HL HH		HAT RUNGS, SOLID STANDARD FOR LADDER TRAYS
BX BH		BOX RUNG, 1" DEEP STANDARD FOR LADDER TRAYS
RS		SLOTTED STRUT RUNG, 1 5/8" DEEP STANDARD FOR LONG-SPAN LADDER TRAY WITH SIDERAIL OF 8" OR LARGER
CS		CORRUGATED SHEET BOTTOM SOLID TROUGH NOT AVAILABLE IN STAINLESS STEEL
UPGRADE RUNG - STEEL M G L T		
SU		SLOTTED STRUT RUNG, 1" DEEP UPGRADE OPTION FOR LADDERS SEE BELOW FOR SLOT DETAIL

RUNG OPTIONS

SLOTTED RUNGS

All PW cable tray metallic ladder systems are available with slotted strut rungs for cable ties. Slots are 0.75" long to accommodate stainless steel banding used in marine applications or any location where extra cable support requires the use of cable ties. Slotted strut rungs are provided with alternating slots up and down to allow for strut accessories to be used both inside the tray and below the cable area. Slotted rungs are designated by the suffix ST (aluminum) or SU (steel) added to the straight sections and fittings catalog numbers.

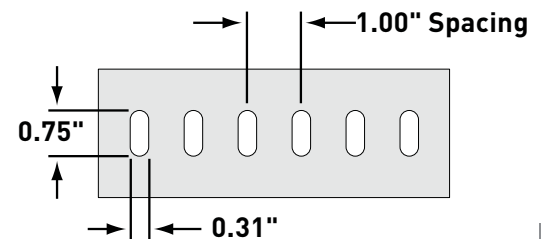

STANDARD RUNGS

This is the standard rung for all 6"-24" wide aluminum ladder trays.

RUNG TYPE	MECHANICAL PROPERTIES
AL I-BEAM	MINIMUM THICKNESS = 0.050" MOMENT OF INERTIA: $I_x = 0.044 \text{ IN}^4$ SECTION MODULUS: $S_x = 0.0869 \text{ IN}^3$

RUNG SPACING	LOAD TYPE	SAFE LOAD LIMITS (LBS/FT)								
		TRAY WIDTH (IN.)								
		6	9	12	18	24	30	36	42	48
6	1	5330	3553	2665	1777	1332	AH	AH	AH	AH
	2	6814	4276	3007	1738	1104	AH	AH	AH	AH
9	1	3553	2369	1777	1184	888	AH	AH	AH	AH
	2	4543	2851	2005	1159	736	AH	AH	AH	AH
12*	1	2665	1777	1332	888	667	AH	AH	AH	AH
	2	3407	2138	1504	869	552	AH	AH	AH	AH
18	1	1777	1184	888	592	444	AH	AH	AH	AH
	2	2271	1425	1002	579	368	AH	AH	AH	AH

This is the standard rung for all aluminum ladder trays 30" and wider.

RUNG TYPE	MECHANICAL PROPERTIES
AH I-BEAM	MINIMUM THICKNESS = 0.070" MOMENT OF INERTIA: $I_x = 0.0510 \text{ IN}^4$ SECTION MODULUS: $S_x = 0.0981 \text{ IN}^3$

RUNG SPACING	LOAD TYPE	SAFE LOAD LIMITS (LBS/FT)								
		TRAY WIDTH (IN.)								
		6	9	12	18	24	30	36	42	48
6	1	AL	AL	AL	AL	AL	1360	1134	972	850
	2	AL	AL	AL	AL	AL	1143	819	588	415
9	1	AL	AL	AL	AL	AL	907	756	648	567
	2	AL	AL	AL	AL	AL	762	546	392	276
12*	1	AL	AL	AL	AL	AL	680	567	486	425
	2	AL	AL	AL	AL	AL	572	410	294	207
18	1	AL	AL	AL	AL	AL	453	378	324	283
	2	AL	AL	AL	AL	AL	381	273	196	138

Standard rung for 8" and larger siderail cable trays. Designed for extremely heavy load applications. This profile will accept strut hardware and accessories. Trays which use this rung will have a load depth equal to the side rail height minus 1 5/8". SR rungs are installed alternating slot up and slot down.

RUNG TYPE	MECHANICAL PROPERTIES
SR SLOTTED†	MINIMUM THICKNESS = 0.102" MOMENT OF INERTIA: $I_x = 0.1848 \text{ IN}^4$ SECTION MODULUS: $S_x = 0.2039 \text{ IN}^3$

RUNG SPACING	LOAD TYPE	SAFE LOAD LIMITS (LBS/FT)								
		TRAY WIDTH (IN.)								
		6	9	12	18	24	30	36	42	48
6	1	9999	8700	6525	4350	3262	2610	2175	1864	1631
	2	9999	8700	6525	4350	3262	2610	2175	1864	1576
9	1	8700	5800	4350	2900	2175	1740	1450	1243	1087
	2	8700	5800	4350	2900	2175	1740	1450	1243	1050
12*	1	6525	4350	3262	2175	1631	1305	1087	932	816
	2	6525	4350	3262	2175	1631	1305	1087	932	788
18	1	4350	2900	2175	1450	1087	870	725	621	544
	2	4350	2900	2175	1450	1087	870	725	621	525



STANDARD CORRUGATED BOTTOM

A

This is the standard corrugated bottom used for all aluminum, solid-bottom tray systems up to and including NEMA Class 20C. Corrugated bottoms are not available in widths greater than 36". For extremely heavy load applications, Ladder type tray is recommended.

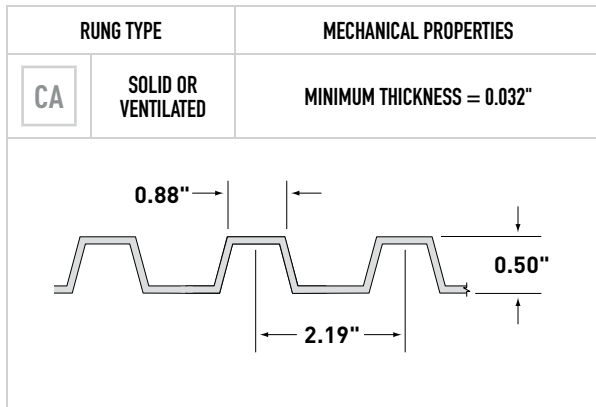

LOAD TYPE	SAFE LOAD LIMITS (LBS/FT)						
	TRAY WIDTH (IN.)						
	6	9	12	18	24	30	36
1	2000	1333	1000	667	500	400	333
2	2000	1333	1000	600	350	200	100

UPGRADE BOTTOM

A

This is the upgrade slotted rung for all aluminum ladder cable tray. This rung is also available for all aluminum ladders for extremely heavy load applications. ST rungs are installed alternating slot up and slot down.

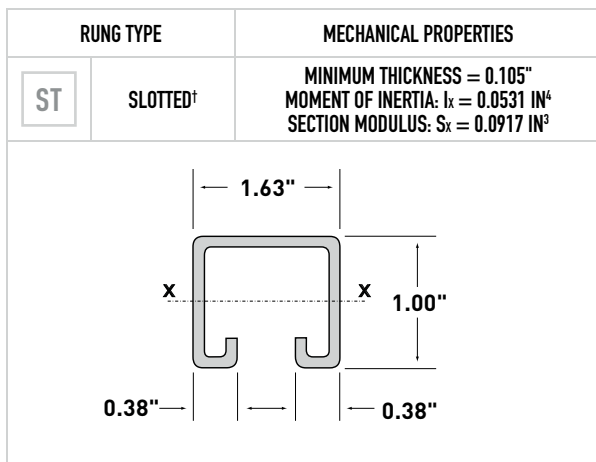

RUNG SPACING	LOAD TYPE	SAFE LOAD LIMITS (LBS/FT)									
		TRAY WIDTH (IN.)									
		6	9	12	18	24	30	36	42	48	
6	1	6602	4402	3301	2201	1651	1320	1100	943	825	
	2	6602	4402	3301	2201	1604	1123	803	574	402	
9	1	4402	2934	2201	1467	1100	880	734	629	550	
	2	4402	2934	2201	1467	1069	749	535	382	268	
12*	1	3301	2201	1651	1100	825	660	550	472	413	
	2	3301	2201	1651	1100	802	562	401	287	201	
18	1	2201	1467	1100	734	550	440	367	314	275	
	2	2201	1467	1100	734	535	374	268	191	134	

1 SAFE LOAD/CABLE LOAD ONLY: Allowable uniformly-distributed cable load expressed in lbs/linear foot of tray length, based on the load carrying capability of the rung with a safety factor of 1.5. To convert Safe Load/Cable Load Only to reflect a safety factor of 2.0, multiply the safe loads shown by 0.75.

* Single rung load capacity: The data shown for 12" rung spacing is equivalent to the load capacity of the single rung.

2 SAFE LOAD / CABLE LOAD +200 LBS: Allowable uniformly-distributed cable load expressed in lbs/linear foot of tray length, based on the load carrying capability of the rung with a 200 lb. concentrated static load applied at the center of the rung, without collapse.

3 Will not support a 200 lb. concentrated static load applied at the center of the rung.

[XX] Two digit code in the safe load limit tables indicates recommended rung option for specified width.

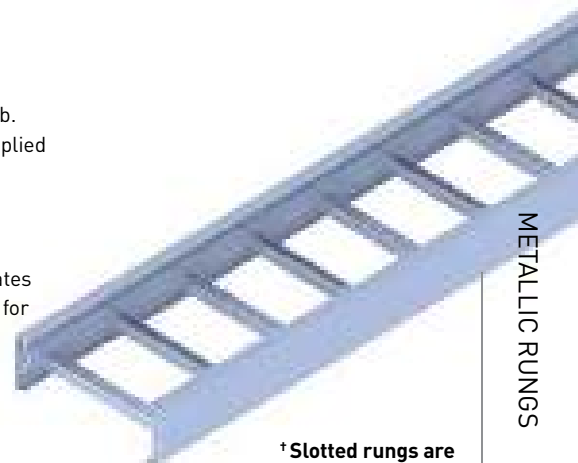

† Slotted rungs are installed alternating slot up and slot down.

METALLIC RUNGS

B.65



STANDARD RUNGS

This is the standard solid rung for the following steel cable trays, up to 24" wide: NEMA Class 12B and 12C ladder with flange-in side rails. NEMA Class 20A, 20B and 20C, mill galvanized, and ladder.

RUNG TYPE	MECHANICAL PROPERTIES
HL	<p>SOLID</p> <p>THICKNESS = 0.038" MOMENT OF INERTIA: $I_x = 0.0143 \text{ IN}^4$ SECTION MODULUS: $S_x = 0.0374 \text{ IN}^3$</p>

RUNG SPACING	LOAD TYPE	SAFE LOAD LIMITS (LBS/FT)								
		TRAY WIDTH (IN.)								
		6	9	12	18	24	30	36	42	48
5	1	3351	2234	1676	1117	838	HH	HH	SU	SU
	2	3351	2234	1480	667	260	HH	HH	SU	SU
6	1	2793	1862	1396	931	698	HH	HH	SU	SU
	2	2793	1862	1233	556	217	HH	HH	SU	SU
9	1	1862	1241	931	621	465	HH	HH	SU	SU
	2	1862	1241	822	370	144	HH	HH	SU	SU
12*	1	1396	931	698	465	349	HH	HH	SU	SU
	2	1396	931	617	278	108	HH	HH	SU	SU

This is the standard solid rung for the following steel cable trays, 30" and 36" wide: NEMA Class 12B and 12C ladder trays with flange-in side rails. NEMA Class 20A, 20B and 20C, mill galvanized, ladder trays.

RUNG TYPE	MECHANICAL PROPERTIES
HH	<p>SOLID</p> <p>THICKNESS = 0.048" MOMENT OF INERTIA: $I_x = 0.0175 \text{ IN}^4$ SECTION MODULUS: $S_x = 0.0456 \text{ IN}^3$</p>

RUNG SPACING	LOAD TYPE	SAFE LOAD LIMITS (LBS/FT)								
		TRAY WIDTH (IN.)								
		6	9	12	18	24	30	36	42	48
5	1	HL	HL	HL	HL	HL	948	790	SU	SU
	2	HL	HL	HL	HL	HL	481	241	SU	SU
6	1	HL	HL	HL	HL	HL	790	659	SU	SU
	2	HL	HL	HL	HL	HL	401	201	SU	SU
9	1	HL	HL	HL	HL	HL	527	439	SU	SU
	2	HL	HL	HL	HL	HL	267	134	SU	SU
12*	1	HL	HL	HL	HL	HL	395	329	SU	SU
	2	HL	HL	HL	HL	HL	201	101	SU	SU

This is the standard rung for all flange-out steel ladders and all flange-in, NEMA Class 20A, 20B, and 20C, hot-dip galvanized steel ladders 6"-24" wide. Please contact Legrand for catalog numbers if this rung is desired for other tray systems.

RUNG TYPE	MECHANICAL PROPERTIES
BX	<p>SOLID</p> <p>MINIMUM THICKNESS = 0.048" MOMENT OF INERTIA: $I_x = 0.0188 \text{ IN}^4$ SECTION MODULUS: $S_x = 0.0343 \text{ IN}^3$</p>

RUNG SPACING	LOAD TYPE	SAFE LOAD LIMITS (LBS/FT)								
		TRAY WIDTH (IN.)								
		6	9	12	18	24	30	36	42	48
6	1	3243	2162	1621	1081	811	BH	BH	BH	BH
	2	3243	2162	1561	774	381	BH	BH	BH	BH
9	1	2162	1441	1081	721	540	BH	BH	BH	BH
	2	2162	1441	1041	516	254	BH	BH	BH	BH
12*	1	1621	1081	811	540	405	BH	BH	BH	BH
	2	1621	1081	781	387	190	BH	BH	BH	BH
18	1	1081	721	540	360	270	BH	BH	BH	BH
	2	1081	721	520	258	127	BH	BH	BH	BH



STANDARD RUNGS

This is the standard rung for all flange-out steel ladders and all flange-in, NEMA Class 20A, 20B, and 20C, hot-dipped galvanized steel ladders 30" and 36" wide. Please contact Legrand for catalog numbers if this rung is desired for other tray systems.

RUNG TYPE	MECHANICAL PROPERTIES
BH SOLID	THICKNESS = 0.060" MOMENT OF INERTIA: $I_x = 0.0227 \text{ IN}^4$ SECTION MODULUS: $S_x = 0.0414 \text{ IN}^3$

RUNG SPACING	LOAD TYPE	SAFE LOAD LIMITS (LBS/FT)								
		TRAY WIDTH (IN.)								
		6	9	12	18	24	30	36	42	48
6	1	BX	BX	BX	BX	BX	816	680	583	510
	2	BX	BX	BX	BX	BX	388	190	49	3
9	1	BX	BX	BX	BX	BX	544	453	389	340
	2	BX	BX	BX	BX	BX	259	127	33	3
12	1	BX	BX	BX	BX	BX	408	340	291	255
	2	BX	BX	BX	BX	BX	194	95	24	3
18	1	BX	BX	BX	BX	BX	272	227	194	170
	2	BX	BX	BX	BX	BX	129	63	16	3

UPGRADE RUNG

This is the upgrade slotted rung for all steel ladder cable trays. SU rungs are installed alternating slot up and slot down.

RUNG TYPE	MECHANICAL PROPERTIES
SU SLOTTED†	THICKNESS = 0.120" MOMENT OF INERTIA: $I_x = 0.0531 \text{ IN}^4$ SECTION MODULUS: $S_x = 0.0921 \text{ IN}^3$

RUNG SPACING	LOAD TYPE	SAFE LOAD LIMITS (LBS/FT)								
		TRAY WIDTH (IN.)								
		6	9	12	18	24	30	36	42	48
6	1	3999	3999	3066	2044	1533	1226	1022	876	766
	2	3999	3999	3066	2044	1499	1040	733	514	350
9	1	3999	2725	2044	1363	1022	818	681	584	511
	2	3999	2725	2044	1363	1000	693	489	343	233
12*	1	3066	2044	1533	1022	766	613	511	438	383
	2	3066	2044	1533	1022	750	520	366	257	175
18	1	2044	1363	1022	681	511	409	341	292	255
	2	2044	1363	1022	681	500	347	244	171	117

1 SAFE LOAD/CABLE LOAD ONLY: Allowable uniformly-distributed cable load expressed in lbs/linear foot of tray length, based on the load carrying capability of the rung with a safety factor of 1.5. To convert Safe Load/Cable Load Only to reflect a safety factor of 2.0, multiply the safe loads shown by 0.75.

2 SAFE LOAD / CABLE LOAD +200 LBS: Allowable uniformly-distributed cable load expressed in lbs/linear foot of tray length, based on the load carrying capability of the rung with a 200 lb. concentrated static load applied at the center of the rung, without collapse.

3 Will not support a 200 lb. concentrated static load applied at the center of the rung.

[XX] Two digit code in the safe load limit tables indicates recommended rung option for specified width.

* Single rung load capacity: The data shown for 12" rung spacing is equivalent to the load capacity of the single rung.

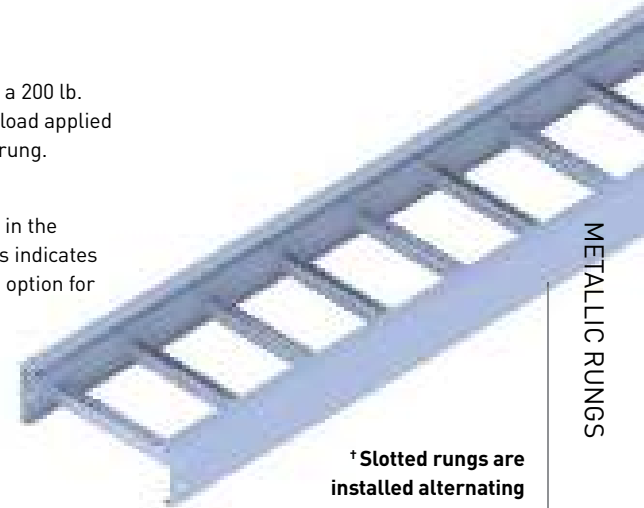

† Slotted rungs are installed alternating slot up and slot down.

METALLIC RUNGS



STANDARD RUNGS

This rung is available for steel ladder tray systems for extremely heavy load applications. This profile will accept strut fasteners and accessories. RS rungs are installed alternating slot up and slot down.

RUNG TYPE	MECHANICAL PROPERTIES
RS	SLOTTED†
THICKNESS = 0.120" MOMENT OF INERTIA: $I_x = 0.1848 \text{ IN}^4$ SECTION MODULUS: $S_x = 0.2040 \text{ IN}^3$	

RUNG SPACING	LOAD TYPE	SAFE LOAD LIMITS (LBS/FT)								
		TRAY WIDTH (IN.)								
		6	9	12	18	24	30	36	42	48
6	1	9999	9991	7494	4996	3747	2997	2498	2141	1873
	2	9999	9991	7494	4996	3747	2997	2498	2141	1873
9	1	9991	6661	4996	3330	2498	1998	1665	1427	1249
	2	9991	6661	4996	3330	2498	1998	1665	1427	1249
12*	1	7494	4996	3747	2498	1873	1499	1249	1071	937
	2	7494	4996	3747	2498	1873	1499	1249	1071	937
18	1	4996	3330	2498	1665	1249	999	833	714	624
	2	4996	3330	2498	1665	1249	999	833	714	624

This is the standard corrugated bottom used for all steel, solid-bottom tray systems up to and including NEMA Class 20C. Corrugated bottoms are not available in widths greater than 36". Please contact Legrand when considering solid bottom trays for extreme load applications.

RUNG TYPE	MECHANICAL PROPERTIES
CS	SOLID OR VENTILATED
MINIMUM THICKNESS = 0.032"	

LOAD TYPE	SAFE LOAD LIMITS (LBS/FT)						
	TRAY WIDTH (IN.)						
	6	9	12	18	24	30	36
1	2007	1338	1003	669	502	401	334
2	2007	1338	1003	599	350	200	100

1 SAFE LOAD/CABLE LOAD ONLY: Allowable uniformly-distributed cable load expressed in lbs/linear foot of tray length, based on the load carrying capability of the rung with a safety factor of 1.5. To convert Safe Load/Cable Load Only to reflect a safety factor of 2.0, multiply the safe loads shown by 0.75.

2 SAFE LOAD / CABLE LOAD +200 LBS: Allowable uniformly-distributed cable load expressed in lbs/linear foot of tray length, based on the load carrying capability of the rung with a 200 lb. concentrated static load applied at the center of the rung, without collapse.

3 Will not support a 200 lb. concentrated static load applied at the center of the rung.

[XX] Two digit code in the safe load limit tables indicates recommended rung option for specified width.

* Single rung load capacity: The data shown for 12" rung spacing is equivalent to the load capacity of the single rung.



† Slotted rungs are installed alternating slot up and slot down.

TRAY LABELS

This is a typical label attached to all PW cable tray straight sections and fittings. It presents important information about the cable tray component and is in accordance with NEMA VE1 guidelines. Labels for fiberglass and stainless steel tray systems are similar. Because these trays are not classified by UL as equipment grounding conductors, they do not have the UL logo or the UL classification text.

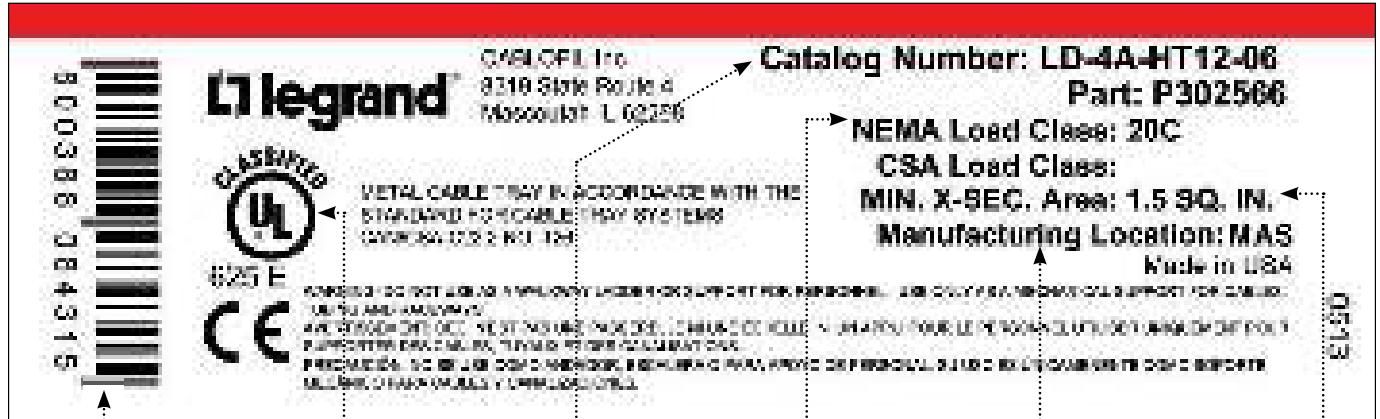

The **UPC code** is used for inventory control.

UL Classification details and the UL logo express the product's grounding qualifications, including the area of metal in the tray side rails.

Catalog Number indicates bottom type, depth, material type and part description per NEMA VE1.

NEMA Load Class is clearly marked.

Manufacturing Location indicates the Legrand manufacturing location from which this product was shipped.

Min. X-Sec. Area Cross sectional area of both tray side rails per NEC Table SB 392.60 (A).

FABRICATION OPTIONS AND ENGINEERING SERVICES

No matter which product you choose, Legrand offers its customers a wide variety of fabrication options and engineering services. We pride ourselves in providing you with the products you need, built to your exact specifications. To help do so, take advantage of our wide range of ancillary services including:

- Take-off and estimating assistance
- Marking special identification numbers on tray labels
- Special identification labels and warning signs
- Custom drawing and design services
- Special packaging and shipment options
- Staging per customer-defined areas

We are pleased to provide customized cable tray to fit your specific needs. Examples of the types of modifications that can be made include but are not limited to:

- Factory-installed divider strips
- Pre-attached connector plates on trays and fittings
- Holes added to tray components for accessory attachments

Contact Legrand at 1-800-658-4641 so that we may discuss your exact job requirements.



FIBERGLASS

F

FIBERGLASS

WIDTHS (W) INCHES

6 | 9 | 12 | 18 | 24 | 30 | 36

RAIL HEIGHTS (H) INCHES

4 | 6

LENGTHS (L) FEET

10 | 20



RAIL HEIGHT (IN.)	LOAD DEPTH (IN.)	RAIL FLANGE (IN.)	NEMA CLASS	CSA CLASS	SERIES	TRAY SYSTEM NUMBER	
						LADDER	SOLID BOTTOM
4	2 ⁷ / ₈	1 ¹ / ₄	12B	C	S1	7400	7D20
6	4 ⁷ / ₈	2	12C, 16A	D, 3M	S1	7615	7F20
	4 ³ / ₄	1 ⁵ / ₈	20C	E, 6M	S2	7625	7F24

MATERIAL:

Manufactured from polyester isophthalic resin conforming with ASTM E-84 Class 1. This material displays good corrosion resistance, including self extinguishing fire retardant properties that comply: UL94 V0, ASTM D-635, ASTM E-662, and FTMS 406-2023.

MECHANICAL PROPERTIES:

Tensile Strength:	20-30.6 kgf/mm ² 28.4-43.5 ksi
Compression Strength:	20-30.6 kgf/mm ² 28.4-43.5 ksi
Flexural Strength:	20-33.6 kfg/mm ² 28.4-43.5 ksi
Shear Strength:	6.1 kgf/mm ² 8.7 ksi
Density:	1.7-1.9 g/cm ³ 0.061-0.069lb/in ³

THERMAL PROPERTIES:

Thermal Conductivity:	0.2-0.3 kcal/(mh °C)
Oxygen Index:	42%
Operating Temperature:	-140 to +120 °C -220 to 248 °F

TEMPERATURE		Polyester resin % of strength
F°	C°	
75	25	100%
100	38	90%
125	50	78%
150	68	68%
175	79	60%
200	90	52%

WEATHER RESISTANCE:

Water Absorption:	24 h = 0.15% 4 days = 0.25%
Weight Increase:	After 500 h = 0.7%

ELECTRICAL PROPERTIES:

Dielectric Strength:	7-15 kV/mm
Insulation Resistance:	10 ¹³ - 10 ¹⁶ ohm

Pultruded profiles display excellent resistance to the effects of UV and weathering.

CONNECTORS & FITTINGS:

Necessary connectors are supplied with all trays. Extra connectors for field cuts or spares must be ordered separately. Supplied in pairs with 316 stainless steel hardware. Fiberglass and fiberglass encapsulated hardware is also available.

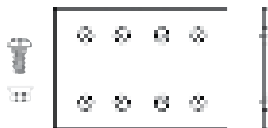
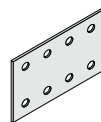

SPLICING

All fiberglass fittings have 5" tangents and splices with 8 predrilled holes. The vertical height of the splice is based upon the tray series.

SUPPORT SPAN (FT.)															
6		8		10		12		14		16		18		20	
SAFE LOAD DATA (LBS./FT.) / DEFLECTION (IN.) / SAFETY FACTOR 1.5															
196	0.38	164	0.85	138	1.61	80	2.08	56	2.57	41	3.04				
		174	0.53	159	0.88	128	1.24	105	1.59	82	1.95	50	2.45		
				278	1.25	246	2.03	215	2.79	183	3.56	152	4.31	120	5.09

RESISTANCE TO VARIOUS CHEMICAL AGENTS			
CHEMICAL AGENT	CONC.	TEMP C°	TEMP F°
Acetic Acid	5%	65	149
Aluminum Sulphate		95	203
Ammonium Nitrate	100%	95	203
Beer		20	68
Benzene		20	68
Calcium Chloride		95	203
Chlorine Gas/Water		20	68
Chromic Acid	5%	95	203
Copper Sulphate		95	203
Ethylene Chlorohydrin		65	149
Ethylene Glycol		95	203
Ferrous Sulphate		95	203
Fatty Acids	100%	95	203
Hydrochloric Acid	1%	95	203
Hydrochloric Acid	10%	65	149
Hydrochloric Acid	37%	25	77
Kerosene		95	203
Magnesium Chloride		95	203
Napthaline		95	203

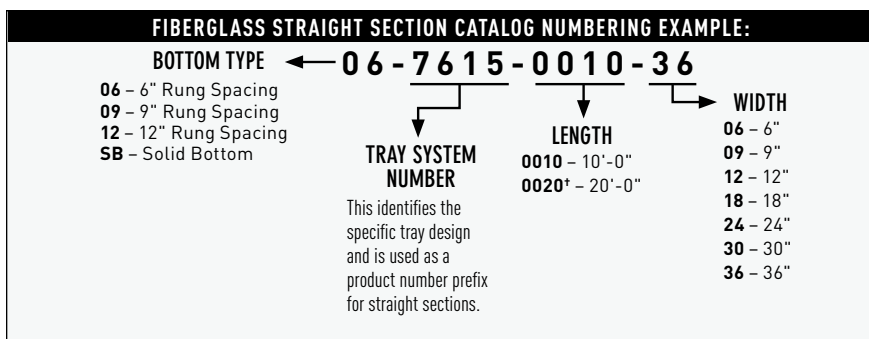
RESISTANCE TO VARIOUS CHEMICAL AGENTS			
CHEMICAL AGENT	CONC.	TEMP C°	TEMP F°
Nitric Acid	30%	20	68
Phosphoric Acid	10%	95	203
Phosphoric Acid	85%	65	149
Salt Water		65	149
Sodium Bicarbonate		65	149
Sodium Bisulphate		25	77
Sodium Carbonate		25	77
Sodium Chloride		95	203
Sodium Hypochlorite	5%	65	149
Sodium Nitrate	100%	95	203
Sodium Silicate		25	77
Sodium Sulphate		95	203
Sulphuric Acid	1%	95	203
Sulphuric Acid	5%	65	149
Sulphuric Acid	10%	76	169
Sulphuric Acid	30%	25	77
Trisodium Phosphate		25	77
Water Sea/lap	100%	50	122
Zinc Sulphate		65	149



HORIZONTAL 90° ELBOW

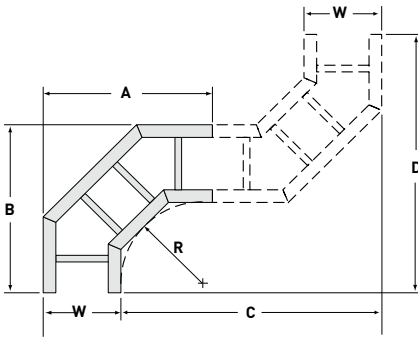

HORIZONTAL 60° ELBOW

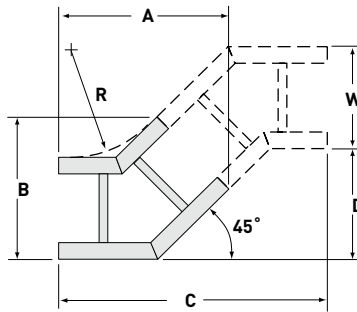

HORIZONTAL 30° ELBOW

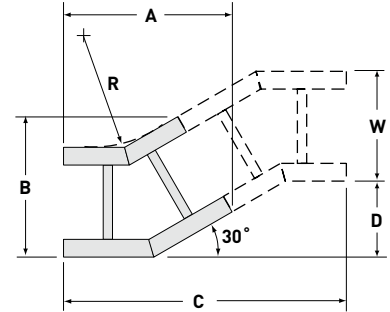

PRODUCT NUMBER RADIUS (IN.)	W	A	B	C	D
9012 12	6	20	20	34	34
	9	23	23	37	37
	12	26	26	40	40
	18	32	32	46	46
	24	38	38	52	52
	30	44	44	58	58
	36	50	50	64	64
9024 24	6	32	32	58	58
	9	35	35	61	61
	12	38	38	64	64
	18	44	44	70	70
	24	50	50	76	76
	30	56	56	82	82
	36	62	62	88	88
9036 36	6	44	44	82	82
	9	47	47	85	85
	12	50	50	88	88
	18	56	56	94	94
	24	62	62	100	100
	30	68	68	106	106
	36	74	74	112	112

PRODUCT NUMBER RADIUS (IN.)	W	A	B	C	D
4512 12	6	16 ¹ / ₈	11	27 ⁷ / ₈	11 ¹ / ₂
	9	18 ¹ / ₄	14	30	12 ¹ / ₂
	12	20 ³ / ₈	17	32 ¹ / ₈	13 ³ / ₈
	18	24 ⁵ / ₈	23	36 ³ / ₈	15 ¹ / ₈
	24	28 ³ / ₄	29	40 ³ / ₄	16 ⁷ / ₈
	30	33 ³ / ₈	35	44 ⁷ / ₈	18 ⁵ / ₈
	36	37 ³ / ₈	41	49 ¹ / ₈	20 ³ / ₈
4524 24	6	24 ⁵ / ₈	14 ¹ / ₂	44 ⁷ / ₈	18 ⁵ / ₈
	9	26 ³ / ₄	17 ¹ / ₂	47	19 ¹ / ₂
	12	28 ⁷ / ₈	20 ¹ / ₂	49 ¹ / ₈	20 ³ / ₈
	18	33 ³ / ₈	26 ¹ / ₂	53 ³ / ₈	22 ¹ / ₈
	24	37 ³ / ₈	32 ¹ / ₂	57 ⁵ / ₈	23 ⁷ / ₈
	30	41 ⁵ / ₈	38 ¹ / ₂	61 ⁷ / ₈	25 ⁵ / ₈
	36	45 ⁷ / ₈	44 ¹ / ₂	66 ¹ / ₈	27 ³ / ₈
4536 36	6	33 ³ / ₈	18	61 ⁷ / ₈	25 ⁵ / ₈
	9	35 ¹ / ₄	21	64	26 ¹ / ₂
	12	37 ³ / ₈	24	66 ¹ / ₈	27 ³ / ₈
	18	41 ⁵ / ₈	30	70 ³ / ₈	29 ¹ / ₈
	24	45 ⁷ / ₈	36	74 ⁵ / ₈	30 ⁷ / ₈
	30	50 ¹ / ₈	42	78 ⁷ / ₈	32 ⁵ / ₈
	36	54 ¹ / ₄	48	83 ¹ / ₈	34 ³ / ₈

PRODUCT NUMBER RADIUS (IN.)	W	A	B	C	D
3012 12	6	12 ² / ₄	8 ³ / ₄	22 ² / ₈	6
	9	14 ¹ / ₄	11 ³ / ₄	23 ⁷ / ₈	6 ³ / ₈
	12	15 ⁵ / ₄	14 ³ / ₄	25 ³ / ₈	6 ³ / ₄
	18	18 ⁸ / ₄	20 ⁰ / ₄	28 ⁸ / ₈	7 ⁵ / ₈
	24	21 ³ / ₄	26 ³ / ₄	31 ³ / ₈	8 ³ / ₈
	30	24 ³ / ₄	32 ² / ₄	34 ³ / ₈	9 ¹ / ₄
	36	27 ³ / ₄	38 ³ / ₄	37 ³ / ₈	10
3024 24	6	18 ³ / ₄	10 ⁰ / ₈	34 ³ / ₈	9 ¹ / ₄
	9	20 ¹ / ₄	13 ³ / ₈	35 ⁷ / ₈	9 ⁵ / ₈
	12	21 ³ / ₄	16 ³ / ₈	37 ³ / ₈	10
	18	24 ² / ₄	22 ² / ₈	40 ⁰ / ₈	10 ³ / ₄
	24	27 ⁰ / ₄	28 ⁰ / ₈	43 ³ / ₈	11 ⁵ / ₈
	30	30 ⁰ / ₄	34 ³ / ₈	46 ³ / ₈	12 ³ / ₈
	36	33 ³ / ₄	40 ⁰ / ₈	49 ³ / ₈	13 ¹ / ₄
3036 36	6	24 ² / ₄	12	46 ³ / ₈	12 ³ / ₈
	9	26 ¹ / ₄	15	47 ⁷ / ₈	12 ⁷ / ₈
	12	27 ³ / ₄	18	49 ³ / ₈	13 ¹ / ₄
	18	30 ⁰ / ₄	24	52 ² / ₈	14
	24	33 ³ / ₄	30	55 ³ / ₈	14 ⁷ / ₈
	30	36 ³ / ₄	36	58 ³ / ₈	15 ⁵ / ₈
	36	39 ³ / ₄	42	61 ³ / ₈	16 ¹ / ₂

WIDTHS (W) INCHES

6 | 9 | 12 | 18 | 24 | 30 | 36

RAIL HEIGHTS (H) INCHES

4 | 6

FIBERGLASS HORIZONTAL ELBOW CATALOG NUMBERING EXAMPLE:

PRODUCT NO.

BOTTOM TYPE ← **LD - 7 6 1 5 - 4 5 1 2 - 3 6** → WIDTH

LD - Ladder
SB - Solid Bottom

↓
TRAY SYSTEM NUMBER

This identifies the specific tray design and is used as a product number prefix for straight sections.

06 - 6"
09 - 9"
12 - 12"
18 - 18"
24 - 24"
30 - 30"
36 - 36"



HORIZONTAL STRAIGHT REDUCER

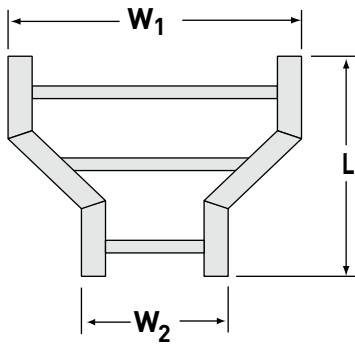

HORIZONTAL LEFT HAND REDUCER

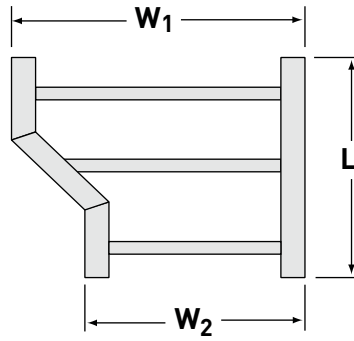

HORIZONTAL RIGHT HAND REDUCER

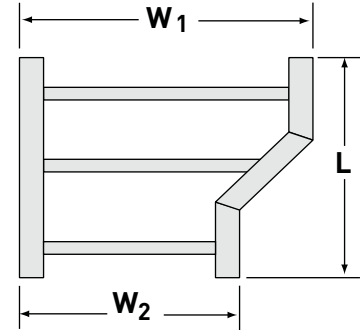

MAIN WIDTH W1	BRANCH WIDTH W2	PRODUCT NUMBER	L
9	6	0109	18 ¹ / ₄
12	6	0112	17 ⁵ / ₈
12	9	0112	18 ¹ / ₄
18	6	0118	20 ⁵ / ₈
18	9	0118	19 ¹ / ₈
18	12	0118	17 ⁵ / ₈
24	6	0124	23 ⁵ / ₈
24	9	0124	22 ¹ / ₈
24	12	0124	20 ⁵ / ₈
24	18	0124	17 ⁵ / ₈
30	6	0130	26 ⁵ / ₈
30	9	0130	25 ¹ / ₈
30	12	0130	23 ⁵ / ₈
30	18	0130	20 ⁵ / ₈
30	24	0130	17 ⁵ / ₈
36	6	0136	29 ⁵ / ₈
36	9	0136	28 ¹ / ₈
36	12	0136	26 ⁵ / ₈
36	18	0136	23 ⁵ / ₈
36	24	0136	20 ⁵ / ₈
36	30	0136	17 ⁵ / ₈

MAIN WIDTH W1	BRANCH WIDTH W2	PRODUCT NUMBER	L
9	6	0709	17 ⁵ / ₈
12	6	0712	20 ⁵ / ₈
12	9	0712	17 ⁵ / ₈
18	6	0718	26 ⁵ / ₈
18	9	0718	23 ⁵ / ₈
18	12	0718	20 ⁵ / ₈
24	6	0724	32 ⁵ / ₈
24	9	0724	29 ⁵ / ₈
24	12	0724	26 ⁵ / ₈
24	18	0724	20 ⁵ / ₈
30	6	0730	38 ⁵ / ₈
30	9	0730	35 ⁵ / ₈
30	12	0730	32 ⁵ / ₈
30	18	0730	26 ⁵ / ₈
30	24	0730	20 ⁵ / ₈
36	6	0736	44 ⁵ / ₈
36	9	0736	41 ⁵ / ₈
36	12	0736	38 ⁵ / ₈
36	18	0736	32 ⁵ / ₈
36	24	0736	26 ⁵ / ₈
36	30	0736	20 ⁵ / ₈

MAIN WIDTH W1	BRANCH WIDTH W2	PRODUCT NUMBER	L
9	6	0809	17 ⁵ / ₈
12	6	0812	20 ⁵ / ₈
12	9	0812	17 ⁵ / ₈
18	6	0818	26 ⁵ / ₈
18	9	0818	23 ⁵ / ₈
18	12	0818	20 ⁵ / ₈
24	6	0824	32 ⁵ / ₈
24	9	0824	29 ⁵ / ₈
24	12	0824	26 ⁵ / ₈
24	18	0824	20 ⁵ / ₈
30	6	0830	38 ⁵ / ₈
30	9	0830	35 ⁵ / ₈
30	12	0830	32 ⁵ / ₈
30	18	0830	26 ⁵ / ₈
30	24	0830	20 ⁵ / ₈
36	6	0836	44 ⁵ / ₈
36	9	0836	41 ⁵ / ₈
36	12	0836	38 ⁵ / ₈
36	18	0836	32 ⁵ / ₈
36	24	0836	26 ⁵ / ₈
36	30	0836	20 ⁵ / ₈

FIBERGLASS HORIZONTAL REDUCER CATALOG NUMBERING EXAMPLE:

PRODUCT NO.

SB - 7 F 20 - 0 1 18 - 1 2

BOTTOM TYPE ← SB - Solid Bottom

TRAY SYSTEM NUMBER ← 7 F 20

This identifies the specific tray design and is used as a product number prefix for straight sections.

W1 W2

- 06 - 6"
- 09 - 9"
- 12 - 12"
- 18 - 18"
- 24 - 24"
- 30 - 30"
- 36 - 36"



HORIZONTAL TEE

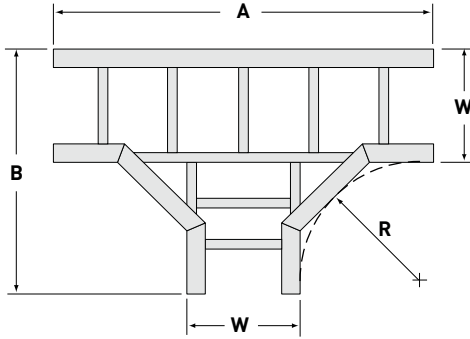

HORIZONTAL CROSS

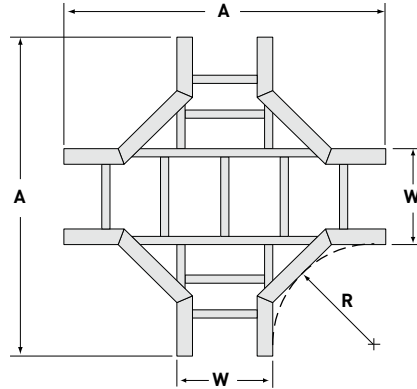

PRODUCT NUMBER RADIUS (IN.)	W	A	B
2012 12	6	34	20
	9	37	23
	12	40	26
	18	46	32
	24	52	38
	30	58	44
	36	64	50
2024 24	6	58	32
	9	61	35
	12	64	38
	18	70	44
	24	76	50
	30	82	56
	36	88	62
2036 36	6	82	44
	9	85	47
	12	88	50
	18	94	56
	24	100	62
	30	106	68
	36	112	74

PRODUCT NUMBER RADIUS (IN.)	W	A
1012 12	6	34
	9	37
	12	40
	18	46
	24	52
	30	58
	36	64
1024 24	6	58
	9	61
	12	64
	18	70
	24	76
	30	82
	36	88
1036 36	6	82
	9	85
	12	88
	18	94
	24	100
	30	106
	36	112

WIDTHS (W) INCHES

6 | 9 | 12 | 18 | 24 | 30 | 36

RAIL HEIGHTS (H) INCHES

4 | 6

RADIUS (R) INCHES

12 | 24 | 36

FIBERGLASS HORIZONTAL TEE CATALOG NUMBERING EXAMPLE:

PRODUCT NO.

← LD - 7 6 1 5 - 4 5 1 2 - 1 2 → WIDTH

LD - Ladder SB - Solid Bottom

↓

TRAY SYSTEM NUMBER

This identifies the specific tray design and is used as a product number prefix for straight sections.

06 - 6"
09 - 9"
12 - 12"
18 - 18"
24 - 24"
30 - 30"
36 - 36"



VERTICAL INSIDE ELBOWS

VERTICAL OUTSIDE ELBOWS

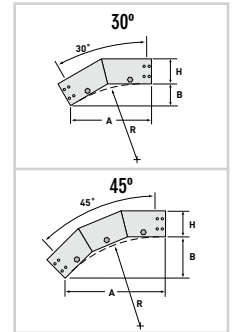
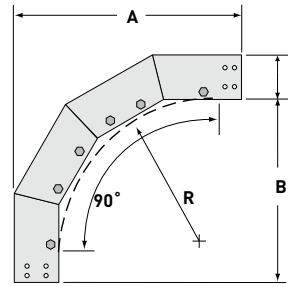
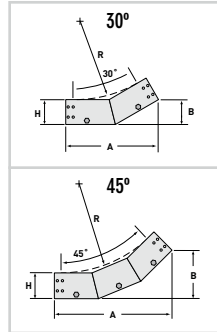
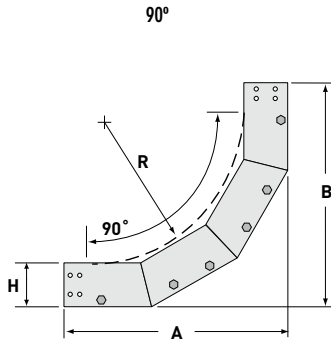

	PRODUCT NUMBER RADIUS (IN.)	W	RAIL HEIGHT (IN.)			
			4		6	
			A	B	A	B
90°	9112 12	ALL	18	18	20	20
	9124 24	ALL	30	30	32	32
	9136 36	ALL	42	42	44	44
45°	4612 12	ALL	14 ³ / ₄	6 ¹ / ₈	16 ¹ / ₈	6 ⁵ / ₈
	4624 24	ALL	23 ¹ / ₄	9 ⁵ / ₈	24 ⁵ / ₈	10 ¹ / ₄
	4636 36	ALL	31 ³ / ₄	13 ¹ / ₈	33 ¹ / ₈	13 ³ / ₄
30°	3112 12	ALL	11 ³ / ₄	3 ¹ / ₈	12 ³ / ₄	3 ³ / ₈
	3124 24	ALL	17 ³ / ₄	4 ³ / ₄	18 ³ / ₄	5
	3136 36	ALL	23 ³ / ₄	6 ³ / ₈	24 ³ / ₄	6 ⁵ / ₈

	PRODUCT NUMBER RADIUS (IN.)	W	RAIL HEIGHT (IN.)			
			4		6	
			A	B	A	B
90°	9212 12	ALL	18	14	20	14
	9224 24	ALL	30	26	32	26
	9236 36	ALL	42	38	44	38
45°	4712 12	ALL	11 ⁷ / ₈	4 ⁷ / ₈	11 ⁷ / ₈	4 ⁷ / ₈
	4724 24	ALL	20 ³ / ₈	8 ¹ / ₂	20 ³ / ₈	8 ¹ / ₂
	4736 36	ALL	28 ⁷ / ₈	12	28 ⁷ / ₈	12
30°	3212 12	ALL	9 ³ / ₄	2 ⁵ / ₈	9 ³ / ₄	2 ⁵ / ₈
	3224 24	ALL	15 ³ / ₄	4 ¹ / ₄	15 ³ / ₄	4 ¹ / ₄
	3236 36	ALL	21 ³ / ₄	5 ⁷ / ₈	21 ³ / ₄	5 ⁷ / ₈

FIBERGLASS INSIDE ELBOW CATALOG NUMBERING EXAMPLE:

PRODUCT NO.

BOTTOM TYPE ← **LD - 7 6 1 5 - 9 1 1 2 - 2 4** → WIDTH

LD - Ladder
SB - Solid Bottom

↓
TRAY SYSTEM NUMBER

This identifies the specific tray design and is used as a product number prefix for straight sections.

06 - 6"
09 - 9"
12 - 12"
18 - 18"
24 - 24"
30 - 30"
36 - 36"



Splice plates and connectors are fire-retardant polyester resin per ASTM E84 Class 1. Sufficient connector pairs with fasteners are automatically included with each shipment of straight sections and fittings. Extras must be ordered separately. Type 316 stainless steel fasteners are included standard, but fiberglass and fiberglass-encapsulated fasteners are options. Tighten flanged hex nut to approximately 10-14 ft.-lbs. of torque.

STANDARD SPLICE F

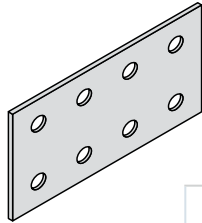

PRODUCT NUMBER	FASTENERS
1302	S6 FG FE
CATALOG NUMBERING EXAMPLE:	
System No.	Fasteners
F 1 -	1302 - S 6

EXPANSION SPLICE F

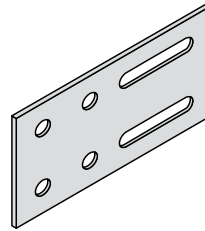

Allows thermal contraction and expansion of tray of up to 1". Tray length and temperature differential govern the spacing and quantity needed.

PRODUCT NUMBER	FASTENERS
1314	S6 FG FE
CATALOG NUMBERING EXAMPLE:	
System No.	Fasteners
F 1 -	1314 - S 6

HORIZONTAL ADJUSTABLE SPLICE F

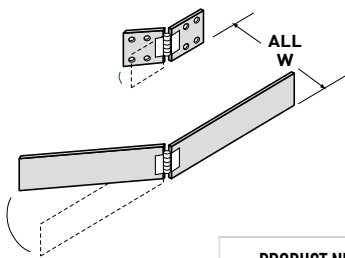

Joins trays at adjustable bend angles up to 30°.

PRODUCT NUMBER	FASTENERS
1305	S6 FG FE
CATALOG NUMBERING EXAMPLE:	
System No.	Fasteners
F 1 -	1305 - S 6

VERTICAL ADJUSTABLE SPLICE F

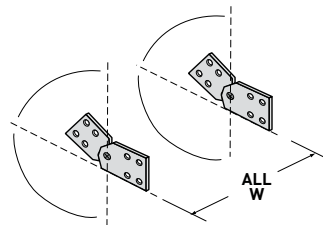

Joins trays at adjustable bend angles up to 90°.

PRODUCT NUMBER	FASTENERS
1307	S6 FG FE
CATALOG NUMBERING EXAMPLE:	
System No.	Fasteners
F 1 -	1307 - S 6

90° CONNECTOR F

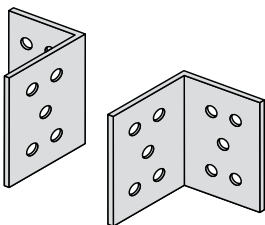

PRODUCT NUMBER	FASTENERS
1320	S6 FG FE
CATALOG NUMBERING EXAMPLE:	
System No.	Fasteners
F 1 -	1320 - S 6

VERTICAL HANGER SPLICE F

Provides vertical support point for trays.

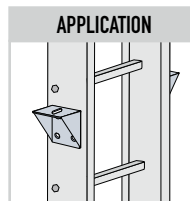
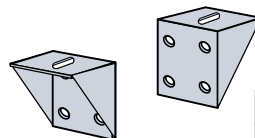

PRODUCT NUMBER	FASTENERS
0356	S6 FG FE
CATALOG NUMBERING EXAMPLE:	
System No.	Fasteners
F 1 -	0356 - S 6

TRAY-TO-BOX CONNECTOR F

Connects tray to the wall or a vertical upright. Hardware for tray attachment only is included.

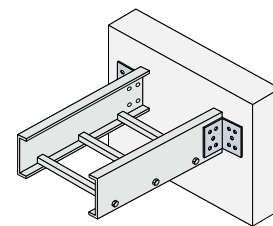

PRODUCT NUMBER	FASTENERS
1864	S6 FG FE
CATALOG NUMBERING EXAMPLE:	
System No.	Fasteners
F 1 -	1864 - S 6



ADDITIONAL RUNG F

Add or replace a tray rung using the hardware provided. Field drilling may be required. Rungs include factory-installed threaded collets.

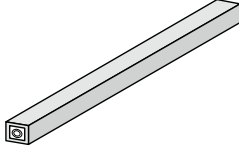

PRODUCT NUMBER	FASTENERS
8200	S6
CATALOG NUMBERING EXAMPLE:	
Material	Width Fasteners
F - 8200	-12-S6

BLIND END PLATE F

Seals off the open end of a cable tray. Attaches to the tray using standard 3/8" dia. connector hardware.

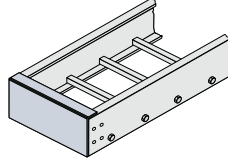

RAIL HEIGHTS (H)
INCHES
4 | 6

PRODUCT NUMBER	FASTENERS
0402	S6 FG FE
CATALOG NUMBERING EXAMPLE:	
System No.	Width Fasteners
6 F I - 0402	-12-S6

CABLE DROPOUT T

Provides a smooth, rounded surface for cables dropping out of the bottom of the cable tray.

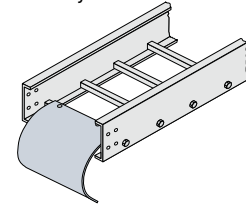

RADIUS	PRODUCT NUMBER	FASTENERS
5	0254	S6
CATALOG NUMBERING EXAMPLE:		
System No.	Width Fasteners	
T I - 0254	-24-S6	

DIVIDER STRIPS F

Straight strips are for use with all straight ladder tray; flexible strips are for use with all horizontal fittings of any radius. Field-drilled holes are required for installation of all divider strips. Clips should be attached to rungs on alternating sides of the divider strip.

RAIL HEIGHTS (H)
INCHES
4 | 6

STRAIGHT HORIZONTAL DIVIDER

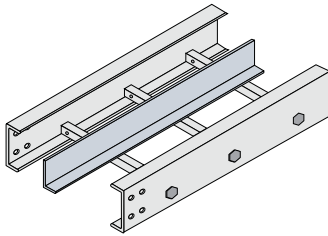

FLEXIBLE HORIZONTAL DIVIDER

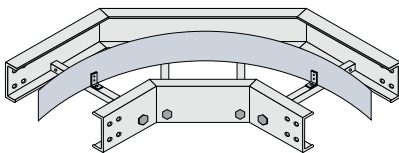

VERTICAL FITTING DIVIDER

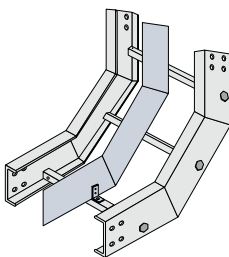

TYPE	PRODUCT NUMBER	LENGTH (FT)
STRAIGHT HORIZONTAL	0010-99	10
(5) THERMOPLASTIC DRIVE RIVETS INCLUDED		

TYPE	PRODUCT NUMBER	LENGTH (FT)
FLEXIBLE HORIZONTAL	0606-99	6
(4) HOLD DOWN CLIPS INCLUDED		

TYPE	PRODUCT NUMBER	RADIUS
VERTICAL 90° INSIDE ELBOW	9112-99	12
	9124-99	24
	9136-99	36
VERTICAL 90° OUTSIDE ELBOW	9212-99	12
	9224-99	24
	9236-99	36
VERTICAL 45° INSIDE ELBOW	4612-99	12
	4624-99	24
	4636-99	36
VERTICAL 45° OUTSIDE ELBOW	4712-99	12
	4724-99	24
	4736-99	36
VERTICAL 30° INSIDE ELBOW	3112-99	12
	3124-99	24
	3136-99	36
VERTICAL 30° OUTSIDE ELBOW	3212-99	12
	3224-99	24
	3236-99	36

(2) HOLD DOWN CLIPS INCLUDED		
CATALOG NUMBERING EXAMPLE:		
System No.		
6 F - 0010-99	-PL	

THERMOPLASTIC DRIVE RIVET

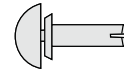

COMPLETE CATALOG NO.
DS-8935-PL

HOLD DOWN CLIP F

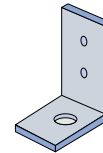

COMPLETE CATALOG NO.
F-1852-PL
(3) THERMOPLASTIC DRIVE RIVETS INCLUDED

FIELD CUTTING SEALANT



Used to reseal fiberglass after field modifications. Can is one pint. Includes two brushes.

COMPLETE CATALOG NO.
0941

FIBERGLASS PREFIX OPTIONS

F1	SERIES1
F2	SERIES2
FI	Flange In



EXPANSION GUIDE CLAMP T

Works as an expansion guide and flips over as a hold down clamp. For use with all ladder tray systems.

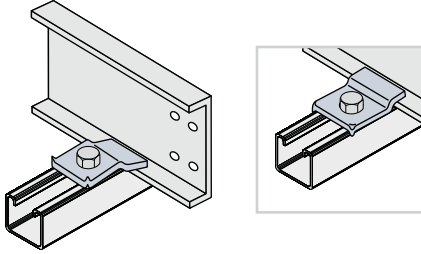

HOLD DOWN CLAMP F

Securely fastens the tray to the support member. For use with all ladder tray systems.

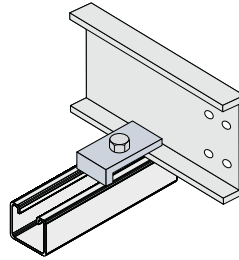

Z-HOLD DOWN CLAMP F T

Securely fastens the tray to the support member and prevents lateral movement. For use with all flange-in tray systems.

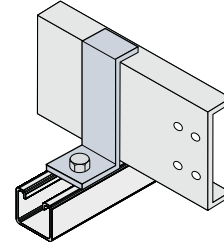

RAIL HEIGHTS (H)
INCHES
4 | 6

PRODUCT NUMBER	FASTENERS INCLUDED	
1893-01	S6	$\frac{3}{8}$ " x $1\frac{1}{2}$ " hex bolt, $\frac{3}{8}$ " flanged nut
1893-02	NONE	
1893-03	S6	$\frac{3}{8}$ " x $1\frac{1}{2}$ " hex bolt, $\frac{3}{8}$ " spring nut
CATALOG NUMBERING EXAMPLE:		
Material	Fasteners	
T - 1893-01 - S6		

PRODUCT NUMBER	FASTENERS INCLUDED	
1811-01	S6 FG	$\frac{3}{8}$ " x $1\frac{1}{2}$ " hex bolt, $\frac{3}{8}$ " flanged nut
1811-02	NONE	
1811-03	S6 FG	$\frac{3}{8}$ " x $1\frac{1}{2}$ " hex bolt, $\frac{3}{8}$ " channel nut
CATALOG NUMBERING EXAMPLE:		
Material	Fasteners	
F - 1811-01 - S6		

PRODUCT NUMBER	FASTENERS INCLUDED	
1866-01	S6 FG	$\frac{1}{4}$ " x $1\frac{1}{2}$ " hex bolt, $\frac{1}{4}$ " flanged nut $\frac{3}{8}$ " x $1\frac{1}{2}$ " hex bolt, $\frac{3}{8}$ " flanged nut
1866-02	NONE	
1866-03	S6 FG	$\frac{1}{4}$ " x $1\frac{1}{2}$ " hex bolt, $\frac{1}{4}$ " spring nut $\frac{3}{8}$ " x $1\frac{1}{2}$ " hex bolt, $\frac{3}{8}$ " spring nut
CATALOG NUMBERING EXAMPLE:		
System No.	Fasteners	
6T - 1866-01 - S6		

SUPPORT BRACKETS F

Support brackets use $1\frac{5}{8}$ " x $1\frac{5}{8}$ " struts. Uniform Design Load is based on a safety factor of 2.0. When selecting "L", allow extra for flanges when supporting a solid bottom tray system.

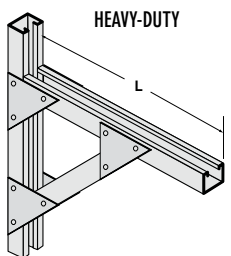
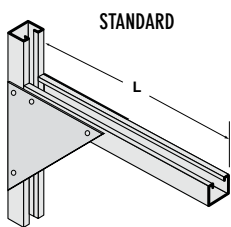

L	STANDARD		HEAVY-DUTY	
	PRODUCT NUMBER	DESIGN LOAD (LBS.)	PRODUCT NUMBER	DESIGN LOAD (LBS.)
7	0386	245	-	-
10	0386	237	-	-
13	0386	230	-	-
16	0386	217	-	-
19	0386	205	0387	610
22	0386	192	-	-
25	0386	180	0387	590
31	-	-	0387	700
37	-	-	0387	700
43	-	-	0387	700
ASSEMBLY HARDWARE				S6
CATALOG NUMBERING EXAMPLE:				
Material	Length			
F - 0386 - 10				

TRAPEZE HANGER SUPPORT KIT (STANDARD DUTY) F T

Made with $1\frac{5}{8}$ " x $1\frac{5}{8}$ " fiberglass strut, designed to accept $\frac{1}{2}$ " threaded rod (sold separately). Includes hardware for ladder trays. For other designs contact Legrand.

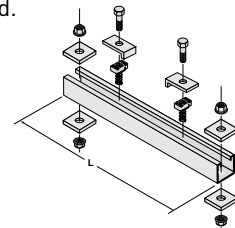

TRAY WIDTH	PRODUCT NUMBER
6	0385-10
9	0385-13
12	0385-16
18	0385-22
24	0385-28
30	0385-34
36	0385-40
FASTENERS INCLUDED	
FG S6	
CATALOG NUMBERING EXAMPLE:	
Material	Length Fasteners
F - 0385-10 - S6	

FIBERGLASS ACCESSORIES



CHANNEL SYSTEMS

METALLIC

B.81 STRAIGHT SECTIONS & COVER

B.82 FITTINGS

B.85 SPLICES & CONNECTORS

FIBERGLASS

B.88 STRAIGHT SECTIONS & COVERS

B.89 FITTINGS

Channel tray is a fabricated metal tray constructed with a one-piece ventilated bottom or solid-bottom channel section. It is commonly used for small runs of cable and for drops from the main cable tray run to equipment or junction boxes.

We offer channel tray in a complete range of materials including aluminum, mill galvanized steel, and steel that is hot-dip galvanized after fabrication. For extremely corrosive applications we offer a wide range of designs in types 304 and 316 stainless steels, polyester and vinylester fiberglass.

Additionally, our product line includes a complete line of accessories including covers and fittings designed to support large-diameter cables.

- Horizontal and vertical fittings are available in 12", 24", and 36" radius
- 4" and 6" widths
- Available in solid and ventilated designs

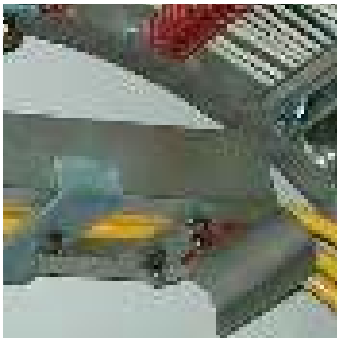

CHANNEL TRAY DESIGN OPTIONS – SOLID BOTTOM

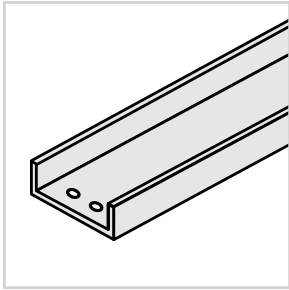

4"

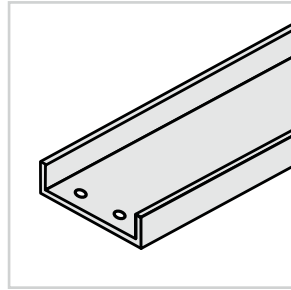

6"

STRAIGHT SECTION CATALOG NUMBERING EXAMPLE:

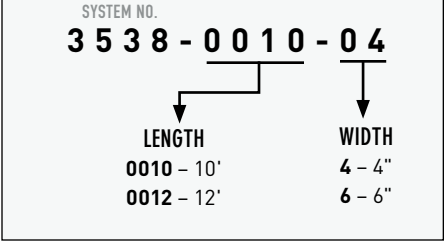

CHANNEL TRAY DESIGN OPTIONS – VENTILATED BOTTOM

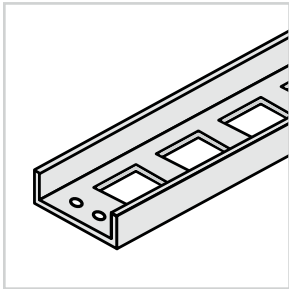

4"

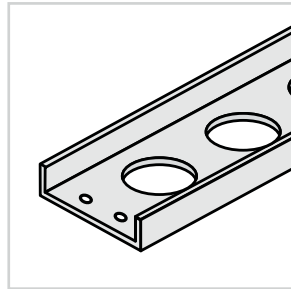

6"

TRAY DEPTH	CHANNEL STYLE	A	M	G	L	T
1 3/4"	SOLID	5509	2509	1509	3538	3529
	VENTILATED*	5508	2508	1508	3532	3528
CLASSIFIED 	U.L. AREA	0.20 IN ²	0.20 IN ²	0.20 IN ²	N/A	N/A
	AMPS	200	200	200	N/A	N/A

WIDTHS (W) INCHES

4 | 6

LENGTHS (L) FEET

10 | 12

*Available in straight sections only. All fittings have solid bottom.

CHANNEL COVER

A M G L T

COVER CONNECTOR

A M T G

FLAT FLANGED

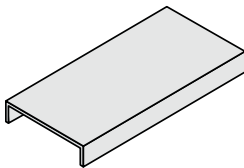

LENGTH (L) FEET

0010 | 10

0012 | 12

WIDTH (W) INCHES

04 | 4

06 | 6

CHANNEL-STYLE

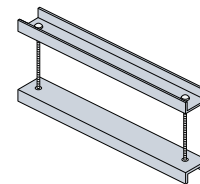

A	M	G	L	T
5088	2085	1085*	3014	3095
CATALOG NUMBERING EXAMPLE (EA.): System Number Length Width 5088 - 0010 - 04				

*Available in 6' length only.

DESCRIPTION	PRODUCT NUMBER	FASTENERS
CHANNEL	1400	ZN S6
CATALOG NUMBERING EXAMPLE (EA.): Material Width Fasteners A - 1400 - 04 - S6		



HORIZONTAL 90° ELBOW

A M G L T

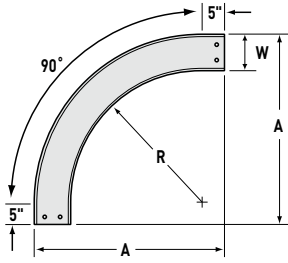

PRODUCT NUMBER RADIUS (IN.)	W	A	B	C	D
9012 12	4	21	-	-	-
	6	23	-	-	-
9024 24	4	33	-	-	-
	6	35	-	-	-
9036 36	4	45	-	-	-
	6	47	-	-	-

HORIZONTAL 60° ELBOW

A M G L T

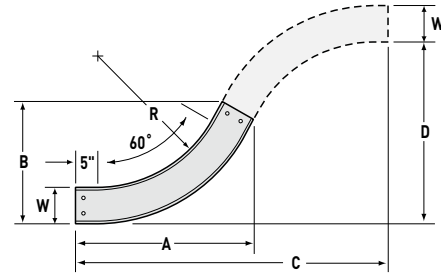

PRODUCT NUMBER RADIUS (IN.)	W	A	B	C	D
6012 12	4	21 ^{3/4}	14 ^{3/8}	39 ^{1/4}	22 ^{3/4}
	6	23 ^{1/2}	16 ^{3/8}	41	23 ^{3/4}
6024 24	4	31 ^{3/4}	20 ^{3/8}	60	34 ^{5/8}
	6	33 ^{1/2}	22 ^{3/8}	61 ^{3/4}	35 ^{5/8}
6036 36	4	42 ^{1/2}	26 ^{3/8}	80 ^{3/4}	46 ^{3/4}
	6	43 ^{1/2}	28 ^{3/8}	82 ^{5/8}	47 ^{3/4}

HORIZONTAL 45° ELBOW

A M G L T

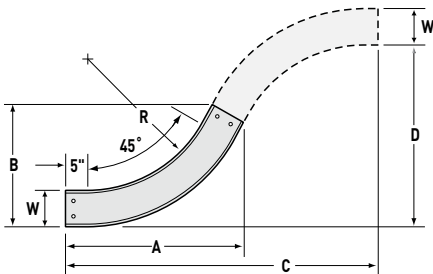

PRODUCT NUMBER RADIUS (IN.)	W	A	B	C	D
4512 12	4	19 ^{7/8}	11 ^{1/8}	36 ^{7/8}	15 ^{1/4}
	6	21 ^{1/4}	13 ^{1/8}	38 ^{1/4}	15 ^{7/8}
4524 24	4	28 ^{3/8}	14 ^{5/8}	53 ^{7/8}	22 ^{3/4}
	6	29 ^{3/4}	16 ^{5/8}	55 ^{1/4}	22 ^{7/8}
4536 36	4	36 ^{7/8}	18 ^{1/8}	70 ^{3/4}	29 ^{3/4}
	6	38 ^{1/4}	20 ^{1/8}	72 ^{1/4}	30

HORIZONTAL 30° ELBOW

A M G L T

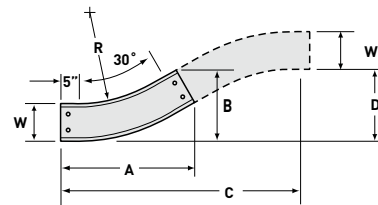

PRODUCT NUMBER RADIUS (IN.)	W	A	B	C	D
3012 12	4	17 ^{3/8}	8 ^{1/8}	32 ^{3/4}	8 ^{1/4}
	6	18 ^{3/8}	10 ^{1/8}	33 ^{3/4}	9
3024 24	4	23 ^{3/8}	9 ^{3/8}	44 ^{3/4}	12
	6	24 ^{3/8}	11 ^{3/8}	45 ^{3/4}	12 ^{1/4}
3036 36	4	29 ^{3/8}	11 ^{3/8}	56 ^{3/4}	14 ^{1/2}
	6	30 ^{3/8}	13 ^{3/8}	57 ^{3/4}	15 ^{1/2}

WIDTHS (W) INCHES

4 | 6

RADIUS (R) INCHES

12 | 24 | 36

HORIZONTAL ELBOW CATALOG NUMBERING EXAMPLE:

SYSTEM NO.	PRODUCT NO.	WIDTH
5509	- 9012	- 06
↓	↓	↓
This identifies the solid bottom straight section tray to be used as a catalog number prefix for all fittings. All fittings are solid bottom only and can be used with ventilated bottom tray.	<p>5509 - A</p> <p>2509 - M</p> <p>1509 - G</p> <p>3538 - L</p> <p>3529 - T</p>	<p>04 - 4"</p> <p>06 - 6"</p>

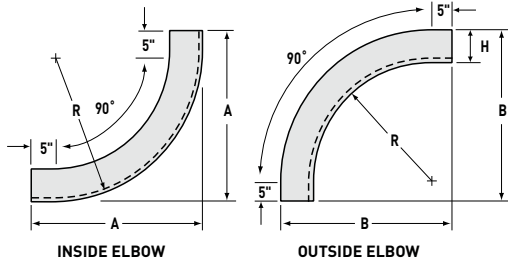

VERTICAL 90° ELBOW
A M G L T

PRODUCT NUMBER RADIUS (IN.)		W	A	B
INSIDE	OUTSIDE			
9112 12	9212 12	4	17	18¾
		6		
9124 24	9224 24	4	29	30¾
		6		
9136 36	9236 36	4	41	42¾
		6		

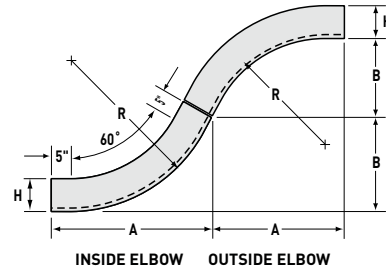
VERTICAL 60° ELBOW
A M G L T

PRODUCT NUMBER RADIUS (IN.)		W	A	B
INSIDE	OUTSIDE			
6112 12	6212 12	4	17¾	10¾
		6		
6124 24	6224 24	4	28¾	16¾
		6		
6136 36	6236 36	4	38¾	22¾
		6		

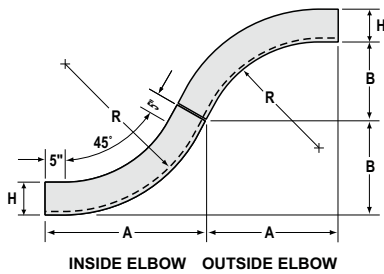
VERTICAL 45° ELBOW
A M G L T

PRODUCT NUMBER RADIUS (IN.)		W	A	B
INSIDE	OUTSIDE			
4612 12	4712 12	4	17	7
		6		
4624 24	4724 24	4	25½	10¾
		6		
4636 36	4736 36	4	34	14¾
		6		

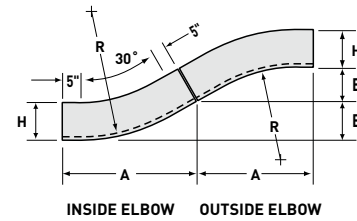
VERTICAL 30° ELBOW
A M G L T

PRODUCT NUMBER RADIUS (IN.)		W	A	B
INSIDE	OUTSIDE			
3112 12	3212 12	4	15¾	4½
		6		
3124 24	3224 24	4	21¾	5¾
		6		
3136 36	3236 36	4	27¾	7¾
		6		

VERTICAL ELBOW CATALOG NUMBERING EXAMPLE:

SYSTEM NO.	PRODUCT NO.	WIDTH
3529	- 9212	- 04

This identifies the solid bottom straight section tray to be used as a catalog number prefix for all fittings. All fittings are solid bottom only and can be used with ventilated bottom tray.

5509 -	A
2509 -	M
1509 -	G
3538 -	L
3529 -	T

04 - 4"
06 - 6"



HORIZONTAL TEE

A M G L T

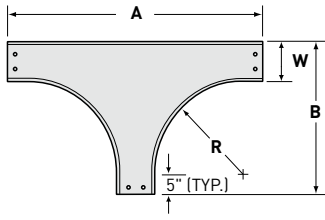

PRODUCT NUMBER RADIUS (IN.)	W	A	B
2012 12	4	38	21
	6	40	23
2024 24	4	62	33
	6	64	35
2036 36	4	86	45
	6	88	47

HORIZONTAL CROSS

A M G L T

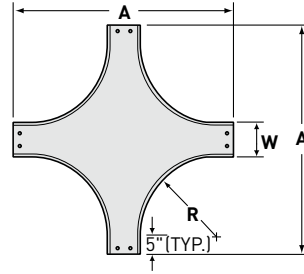

PRODUCT NUMBER RADIUS (IN.)	W	A
1012 12	4	38
	6	40
1024 24	4	62
	6	64
1036 36	4	86
	6	88

CABLE DROPOUT

A M T G*

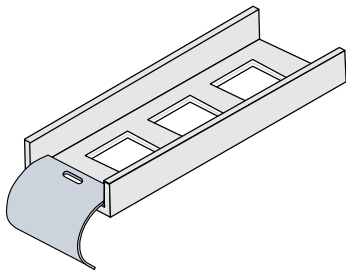

PRODUCT NUMBER	RADIUS	FASTENERS INCLUDED
0253	¾"	ZN S6
CATALOG NUMBERING EXAMPLE:		
Material	Width	Fasteners
A - 0253	- 04	- ZN

BLIND END PLATE

A M T G*

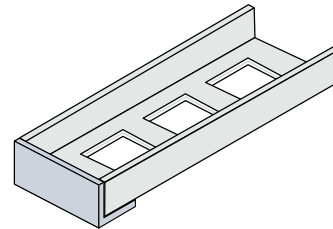

PRODUCT NUMBER	FASTENERS INCLUDED
0402	GE S6
CATALOG NUMBERING EXAMPLE:	
Material	Width Fasteners
A - 0402	- 06 - S6

CHANNEL METALLIC FITTINGS

WIDTHS (W) INCHES

4 | 6

RADIUS (R) INCHES

12 | 24 | 36

HORIZONTAL TEE CATALOG NUMBERING EXAMPLE:

SYSTEM NO. PRODUCT NO. WIDTH
5509 - 2012 - 06

This identifies the specific solid bottom straight section tray design and is used as a catalog number prefix for all fittings.

- 5509 - A
- 2509 - M
- 1509 - G
- 3538 - L
- 3529 - T

04 - 4"
06 - 6"
G* = optional



CHANNEL-TO-BOX CONNECTOR

A G T

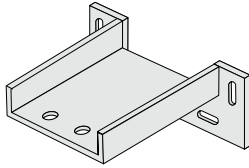

PRODUCT NUMBER		FASTENERS	
0403		GE	S6
CATALOG NUMBERING EXAMPLE:			
Material	Width	Fasteners	
A - 0403	- 04	- GE	

CHANNEL-TO-FLOOR BASE PLATE

G T

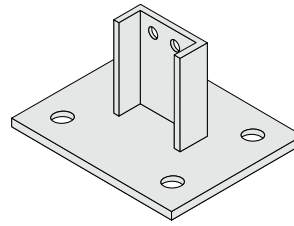

PRODUCT NUMBER	
1812	
CATALOG NUMBERING EXAMPLE:	
Material	Width
G - 1812	- 04

CHANNEL-TO-TRAY CONNECTOR

A G T

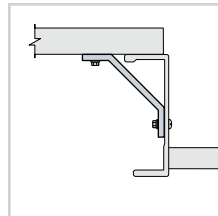
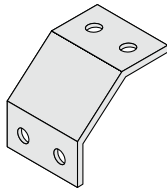

PRODUCT NO.	FASTENERS INCLUDED
1338	GE S6
CATALOG NUMBERING EXAMPLE:	
Material	Width Fasteners
A - 1338	- 04 - GE

OVERHEAD HANGER BRACKET

G T

SINGLE

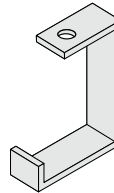

DOUBLE

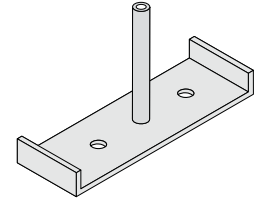

DESCRIPTION	PRODUCT NUMBER	ROD SIZE
SINGLE	0333	1/2"
	0341	3/8"
DOUBLE	0334	1/2"
CATALOG NUMBERING EXAMPLE (EA.):		
Material	Width	
G - 0333	- 04	

WALL BRACKET

G T

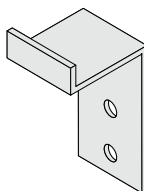

PRODUCT NUMBER	
1803	
CATALOG NUMBERING EXAMPLE:	
Material	Width
G - 1803	- 04



STANDARD SPLICE

A G T

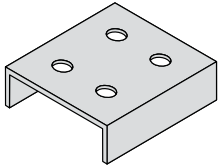

HORIZONTAL ADJUSTABLE SPLICE

A G T

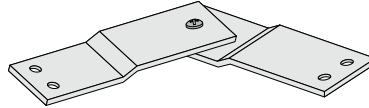

Bonding jumpers are required.



VERTICAL ADJUSTABLE SPLICE

A G T

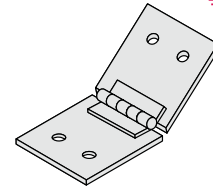

Bonding jumpers are required.



PRODUCT NO.	FASTENERS INCLUDED
1301	GE S6
CATALOG NUMBERING EXAMPLE:	
Material	Width Fasteners
T - 1301	-04 - S6

PRODUCT NO.	FASTENERS INCLUDED
1305	GE S6
CATALOG NUMBERING EXAMPLE:	
Material	Width Fasteners
A - 1305	-06 - GE

PRODUCT NO.	FASTENERS INCLUDED
1307	GE S6
CATALOG NUMBERING EXAMPLE:	
Material	Width Fasteners
T - 1307	-06 - S6

VERTICAL HANGER SPLICE

A G T

Functions as a splice plate while offering a means of supporting the channel vertically from two 1/2" threaded rods (purchased separately). Fasteners for channel connection only is included.

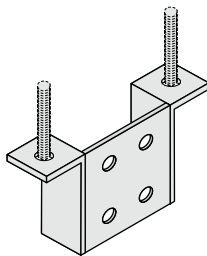

PRODUCT NUMBER	FASTENERS
0357	GE S6
CATALOG NUMBERING EXAMPLE:	
Material	Width Fasteners
A - 0357	-04 - GE

MOUNTING BRACKET

A G T

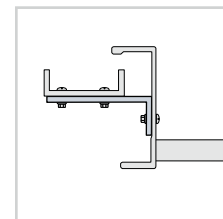
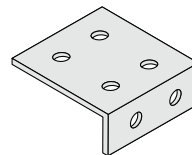

PRODUCT NO.	FASTENERS INCLUDED
1357	GE S6
CATALOG NUMBERING EXAMPLE:	
Material	Width Fasteners
A - 1357	-04 - S6



HOLD DOWN CLAMP

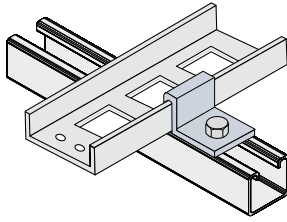

EXPANSION GUIDE CLAMP

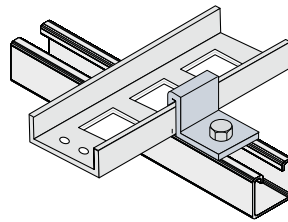

HOLD DOWN/COVER CLAMP

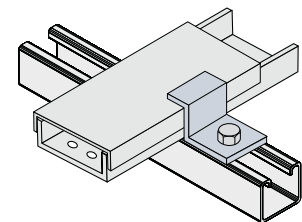

PRODUCT NUMBER

1870

CATALOG NUMBERING EXAMPLE:

Material
T - 1870

PRODUCT NUMBER

1871

CATALOG NUMBERING EXAMPLE:

Material
A - 1871

PRODUCT NUMBER

1872

CATALOG NUMBERING EXAMPLE:

Material
T - 1872

SLIP-ON LOCK NUT®



Allows the user to slip the nut onto a rod, without actually threading it. Ideal for when nuts must be added to a rod, but cannot be threaded due to previously-installed equipment.

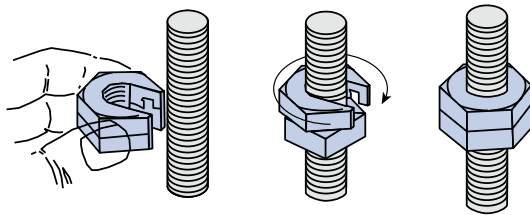

FIBERGLASS ENCAPSULATED STAINLESS STEEL HEX BOLT/NUT



To obtain the strength of stainless steel as well as the corrosion resistance of fiberglass, use PW's 316 stainless steel hex nut and hex bolt encapsulated in fire retardant fiberglass.

Designed for use with all PW fiberglass cable trays shown in this catalog.

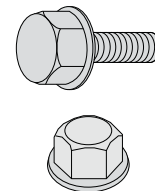

PRODUCT NO.	SIZE
SON 1/4	1/4"-20
SON 3/8	3/8"-16
SON 1/2	1/2"-13
CATALOG NUMBERING EXAMPLE:	
Fasteners	
SON 3/8 - Z N	

DESCRIPTION	COMPLETE CATALOG NO.	SIZE	GRIP RANGE
BOLT	DS-8953-05-FE	3/8"-16 x 1"	0.35" TO 0.50"
NUT	DS-8954-01-FE	3/8"	N/A



FIBERGLASS CHANNEL TRAY

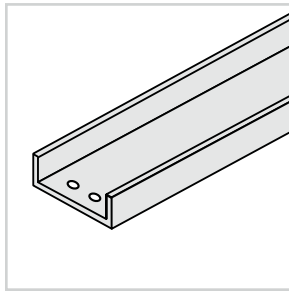

SOLID BOTTOM

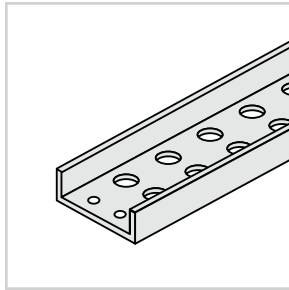

VENTILATED BOTTOM

CHANNEL STYLE	F
SOLID	7509
VENTILATED*	7508

COVER (NOT SHOWN)	F
FLAT, SOLID	7134

*Available in straight sections only. All fittings have solid bottom.

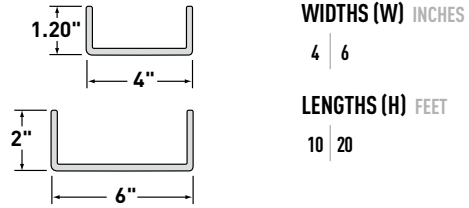

HORIZONTAL ELBOWS

PRODUCT NUMBER	W	A
9012	4	18
12	6	20
9024	4	30
24	6	32
9036	4	42
36	6	44

PRODUCT NUMBER	W	A	B
4512	4	14 $\frac{3}{4}$	8 $\frac{7}{8}$
12	6	16 $\frac{5}{8}$	10 $\frac{3}{8}$
4524	4	23 $\frac{3}{4}$	12 $\frac{1}{2}$
24	6	24 $\frac{5}{8}$	14 $\frac{1}{2}$
4536	4	31 $\frac{3}{4}$	16
36	6	33 $\frac{3}{8}$	18

CHANNEL FIBERGLASS STRAIGHT SECTIONS & FITTINGS

WIDTHS (W) INCHES

4 | 6

LENGTHS (H) FEET

10 | 20

RADIUS (W) INCHES

12 | 24 | 36

HORIZONTAL ELBOW CATALOG NUMBERING EXAMPLE:

SYSTEM NO. PRODUCT NO. WIDTH
7 5 0 9 - 9 0 1 2 - 0 6

Solid bottom straight section tray design is used as a catalog number prefix for all fittings.

WIDTH
 4 - 4"
 6 - 6"

7509 - **F**

HORIZONTAL TEE

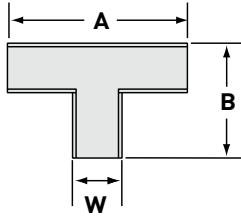

PRODUCT NUMBER	W	A	B
2000	4	14	9
	6	16	11

HORIZONTAL CROSS

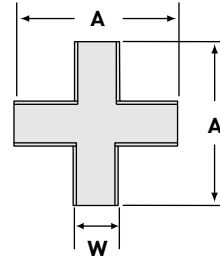

PRODUCT NUMBER	W	A
1000	4	14
	6	16

90° VERTICAL ELBOWS

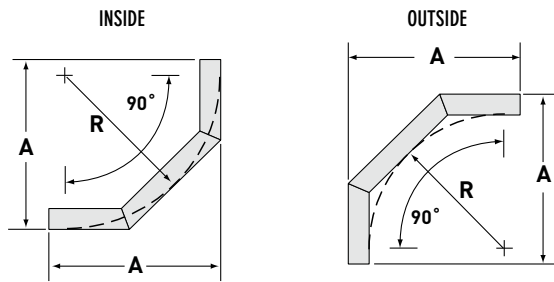

W	INSIDE		OUTSIDE	
	PRODUCT NUMBER RADIUS (IN.)	A	PRODUCT NUMBER RADIUS (IN.)	A
4	9112	14	9212	15
6	12	14	12	15 7/8
4	9124	26	9224	27
6	24	26	24	27 7/8
4	9136	38	9236	39
6	36	38	36	39 7/8

45° VERTICAL ELBOWS

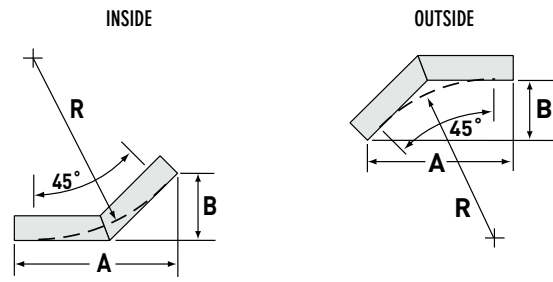

W	INSIDE			OUTSIDE		
	PRODUCT NUMBER RADIUS (IN.)	A	B	PRODUCT NUMBER RADIUS (IN.)	A	B
4	4612	12	5	4712	11 3/8	4 7/8
6	12	12	5	12	11 3/8	4 7/8
4	4624	20 3/8	8 1/2	4724	20 3/8	8 3/8
6	24	20 3/8	8 1/2	24	20 3/8	8 3/8
4	4636	28 7/8	12	4736	28 3/8	11 1/8
6	36	28 7/8	12	36	28 3/8	11 1/8

HORIZONTAL TEE CATALOG NUMBERING EXAMPLE:

SYSTEM NO. PRODUCT NO. WIDTH
7 5 0 9 - 2 0 0 0 - 0 6

Solid bottom straight section tray design is used as a catalog number prefix for all fittings.

7509 - **F**

WIDTH
 4 - 4"
 6 - 6"



CABLE RUNWAY

B.91 STRAIGHT SECTIONS

B.92 FITTINGS

B.93 SPLICES, CONNECTORS & ACCESSORIES



Cable Runway is available in two styles, tubular side rails that are lightweight yet strong and solid-bar side rails that offer maximum support strength. Both styles utilize rungs made of tubular steel.

Cable runway is commonly used in telecommunications and voice and data applications. Specific application examples include, computer data centers, server farms, 911 call centers, network control centers, telephone/wireless communication centers, and phone/data closets in commercial office buildings.

Available finishes include Yellow-zinc dichromate that is ideally used where the runway needs to be UL Classified for use as an equipment ground conductor. Powder-coated finishes are available in standard black and optional light gray.

- Available in 6", 9", 12", 18", and 24" widths
- Available in Solid and Tubular side rail designs
- All rails are 10' in length

CABLE RUNWAY STANDARD DESIGN

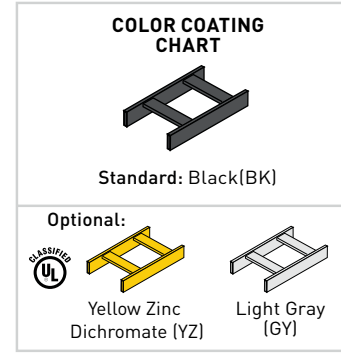
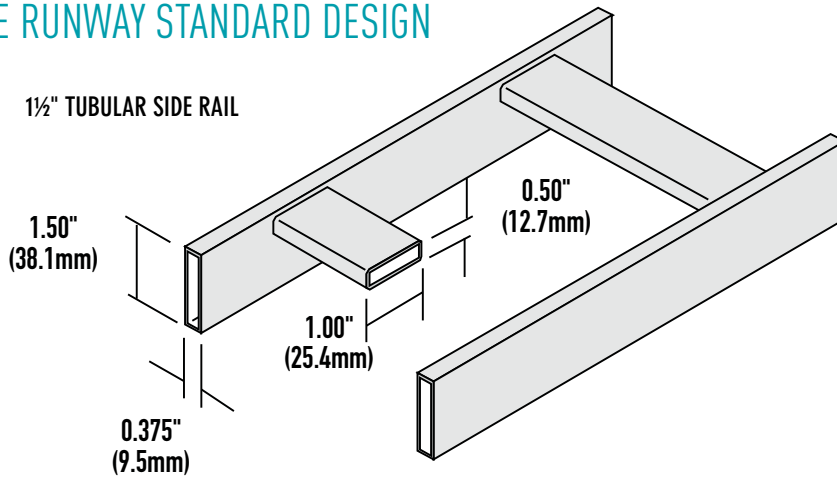

CABLE RUNWAY OPTIONAL DESIGNS

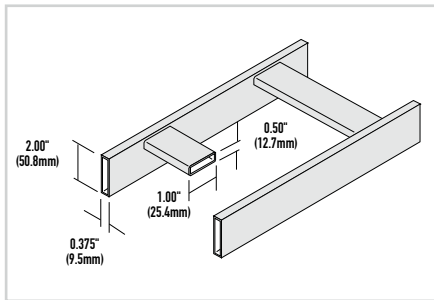

2" TUBULAR SIDE RAIL

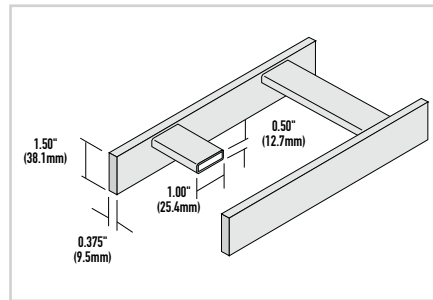

1 1/2" SOLID SIDE RAIL

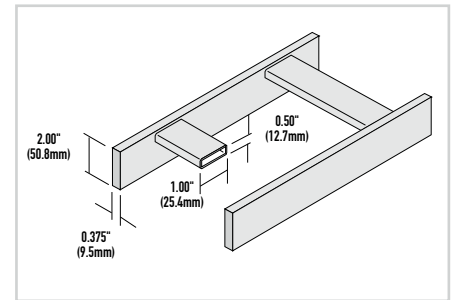

2" SOLID SIDE RAIL

STANDARD DESIGN

TYPE	PRODUCT NUMBER	RAIL HEIGHT*	SUPPORT SPAN (FT.) SAFE LOAD (LBS./FT.) / DEFLECTION (IN.)									
			4	5	6	7	8					
TUBULAR	8104	1 1/2	248	0.41	159	0.63	110	1.19	81	1.24	62	1.62

OPTIONAL DESIGNS

TUBULAR	8204	2	300*	0.29	274	0.65	190	0.93	140	1.27	107	1.66
SOLID	8106	1 1/2	300*	0.26	300*	0.62	251	1.08	184	1.47	141	1.92
SOLID	8206	2	300*	0.11	300*	0.26	300*	0.54	246	0.82	188	1.07

* 1 1/2 tubular rail height is standard; 1 1/2 solid rail and 2" tubular and solid rail is optional and available by special order only.

RAIL HEIGHTS (H) INCHES

1.5 | 2

WIDTH (W) INCHES

6 | 9 | 12 | 18 | 24

LENGTH (L) FEET

10

SAFE LOAD: Allowable uniformly distributed load based on simple beam type supports with a safety factor of 1.5. Safe load data is based on the performance of the cable runway side rails. An asterisk (*) denotes rung limitation.

DEFLECTION: Side rail deflection measured at the midspan of the runway, based on simple beam type supports and uniformly distributed loads. When trays are erected in a continuous system, the midspan deflection decreases by as much as 40%.

MATERIAL: Rectangular Steel Tube per ASTM-A513 and Rectangular Steel Solid Bar per ASTM-A36.

CONSTRUCTION: Tubular rungs are attached to side rails by arc welding.

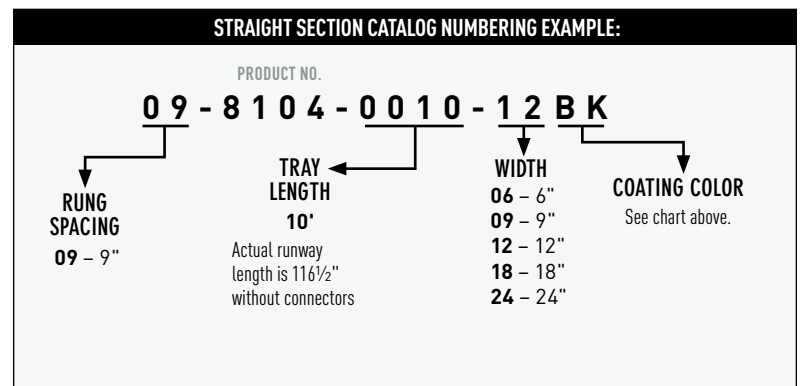

90° HORIZONTAL ELBOW

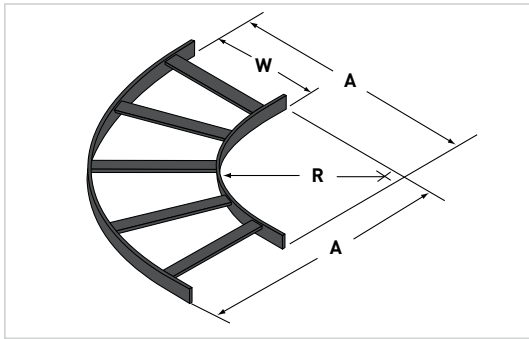

CATALOG NUMBER RADIUS	W	A
9012 12"	6	21
	9	24
	12	27
	18	33
	24	39

90° VERTICAL INSIDE ELBOW

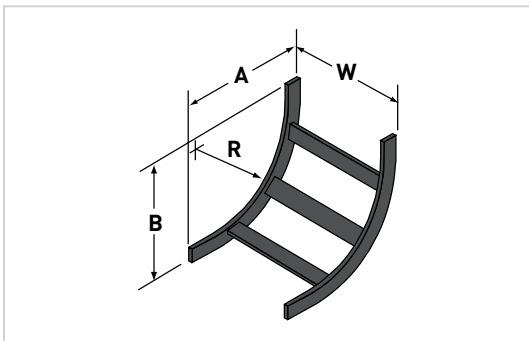

CATALOG NUMBER RADIUS	W	SIDE RAIL HEIGHT			
		1½		2	
		A	B	A	B
9112 12"	6	16½	16½	17	17
	9	16½	16½	17	17
	12	16½	16½	17	17
	18	16½	16½	17	17
	24	16½	16½	17	17

90° VERTICAL OUTSIDE ELBOW

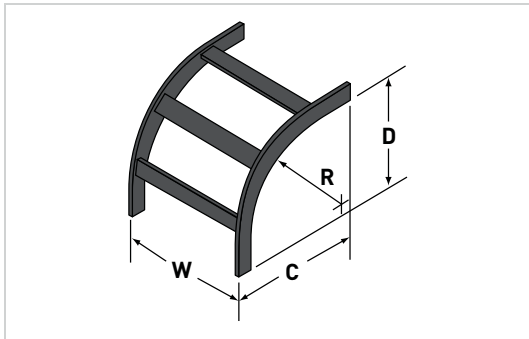

CATALOG NUMBER RADIUS	W	SIDE RAIL HEIGHT			
		1½		2	
		C	D	C	D
9212 12"	6	16½	15	17	15
	9	16½	15	17	15
	12	16½	15	17	15
	18	16½	15	17	15
	24	16½	15	17	15

HORIZONTAL ELBOW CATALOG NUMBERING EXAMPLE:

SYSTEM NO.	PRODUCT NO.
09-8104-9012-24BK	
↓ RUNG SPACING 09 - 9"	↓ WIDTH 06 - 6" 09 - 9" 12 - 12" 18 - 18" 24 - 24"
	↓ COATING COLOR

COLOR COATING CHART

Standard: Black(BK)

Optional:

Yellow Zinc
Dichromate (YZ)

Light Gray
(GY)

WIDTHS (W) INCHES

6 | 9 | 12 | 18 | 24

RUNWAY PREFIX OPTIONS

R	ALL SIZES
1R	1½" SIDERAIL (8104, 8106)
2R	2" SIDERAIL (8204, 8206)

SPLICE

Connects runway sections. Sold in pairs.

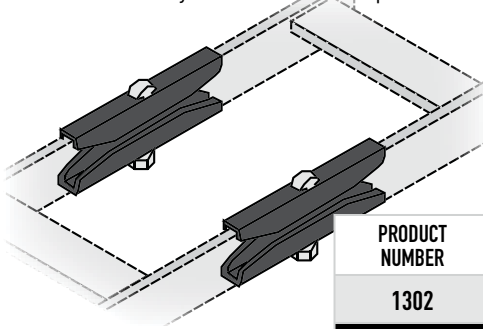

PRODUCT NUMBER	FASTENERS INCLUDED
1302	ZN
CATALOG NUMBERING EXAMPLE:	
System No.	Fasteners Coating
1 R -	1302 - ZN - BK

90° HORIZONTAL CONNECTOR

Joins runway sections at a 90° horizontal angle. Sold in pairs.

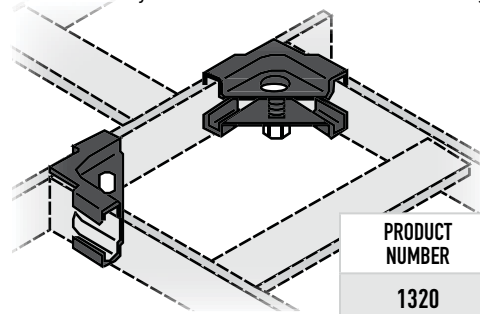

PRODUCT NUMBER	FASTENERS INCLUDED
1320	ZN
CATALOG NUMBERING EXAMPLE:	
System No.	Fasteners Coating
1 R -	1320 - ZN - BK

90° VERTICAL CONNECTOR

Joins runway sections at a 90° vertical angle. Sold in pairs.

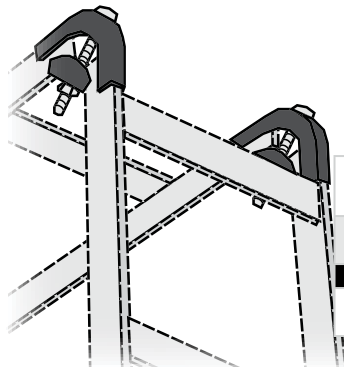

PRODUCT NUMBER	FASTENERS INCLUDED
1331-90	ZN
CATALOG NUMBERING EXAMPLE:	
System No.	Fasteners Coating
1 R -	1331-90 - ZN - BK

45° VERTICAL CONNECTOR

Joins runway sections at a 45° vertical angle. Sold in pairs.

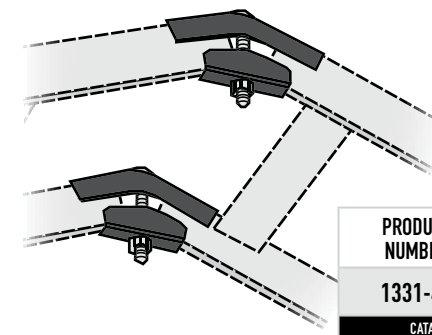

PRODUCT NUMBER	FASTENERS INCLUDED
1331-45	ZN
CATALOG NUMBERING EXAMPLE:	
System No.	Fasteners Coating
1 R -	1331-45 - ZN - BK

FLOOR/WALL SUPPORT BRACKET KIT

Connects runway to the floor or wall and acts as a support point. Includes the splice connector and foot support. Attachment hardware is not included. Sold in pairs.

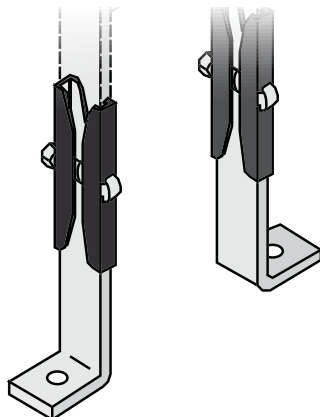

PRODUCT NUMBER	FASTENERS INCLUDED
0339	ZN
CATALOG NUMBERING EXAMPLE:	
System No.	Fasteners Coating
1 R -	0339 - ZN - BK

VERTICAL WALL BRACKET

Secures runway to the wall or floor. Sized for 3/8" hardware (not included). Sold in pairs.

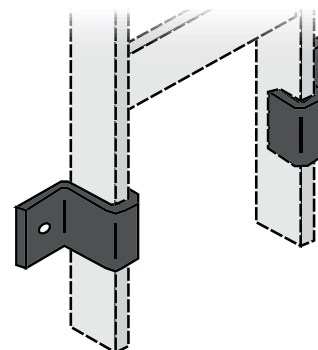

PRODUCT NUMBER
0426
CATALOG NUMBERING EXAMPLE:
System No.
Coating
1 R -
0426 - BK



CABLE DROPOUT

Provides a smooth surface for cables to drop out of runway with a 3" radius bend. Attaches to both rungs and siderails.

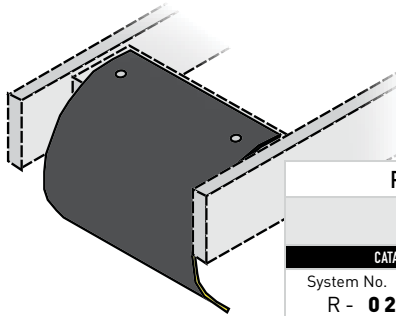

PRODUCT NUMBER	
0254	
CATALOG NUMBERING EXAMPLE:	
System No.	W Fasteners Coating
R - 0254	- 06 - ZN - BK

PROTECTIVE END CAP

Protects the exposed ends of runway side rails. Plastic material. Sold in pairs.

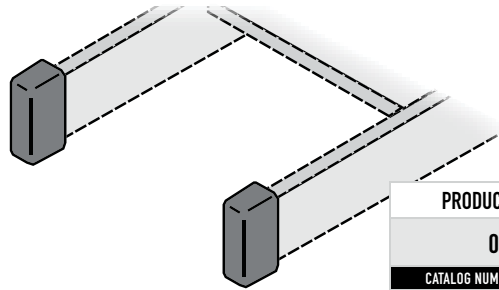

PRODUCT NUMBER	
0410	
CATALOG NUMBERING EXAMPLE:	
System No.	W Fasteners Coating
1 R - 0410	

CABLE RETAINING POSTS

Posts add load depth to cable runway. Includes one post, one bracket, and one end cap. Posts are typically installed on 12" centers.

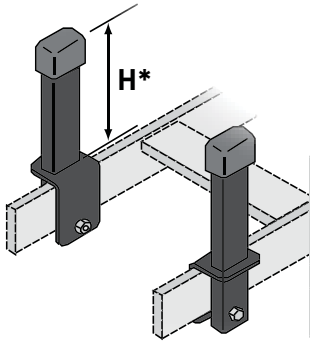

HEIGHTS (H) INCHES

4 | 6 | 8

PRODUCT NUMBER	FASTENERS INCLUDED
A330	ZN
CATALOG NUMBERING EXAMPLE:	
System No.	H Fasteners Coating
1 R - A330	- 08 - ZN - BK

L-BRACKET

Bracket provides a separate facility for running power conductors or other cables that should be physically separated from main cables.

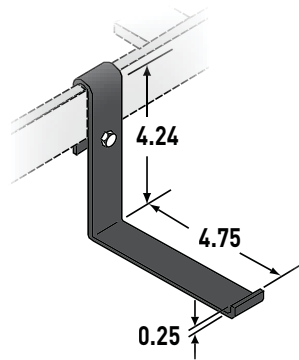

PRODUCT NUMBER	FASTENERS INCLUDED
A834	ZN
CATALOG NUMBERING EXAMPLE:	
System No.	Fasteners Coating
1 R - A834	- ZN - BK

WALL ANGLE SUPPORT KIT

Supports cable runway against wall or upright vertical surface. Angle length and hole spacing is based on the specified width. Kit includes hardware for tray attachment, but wall attachment hardware is not included. Standard finish is black epoxy powder coat.

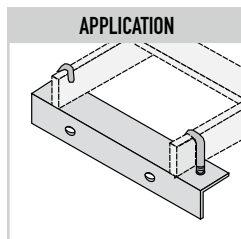
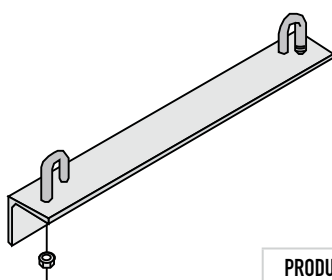

PRODUCT NUMBER	FASTENERS INCLUDED
0403	ZN
CATALOG NUMBERING EXAMPLE:	
System No.	W Fasteners Coating
R - 0403	- 06 - ZN - BK

WALL BRACKET

Supports cable runway against the wall or an upright vertical surface. Hardware for runway attachment is included. Standard finish is black epoxy powder coat.

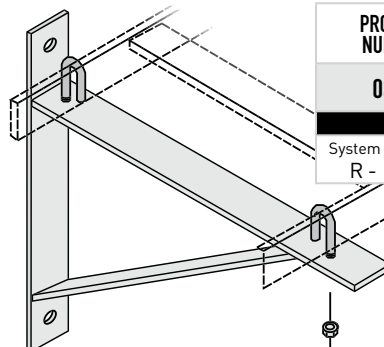

PRODUCT NUMBER	FASTENERS INCLUDED
0349	ZN
CATALOG NUMBERING EXAMPLE:	
System No.	W Fasteners Coating
R - 0349	- 09 - ZN - BK



CENTER HUNG SUPPORT KIT

Supports cable runway from the ceiling using a single threaded rod. Kit includes one support bracket and hardware for tray attachment. Standard finish is black epoxy powder coat. Threaded rod is purchased separately.

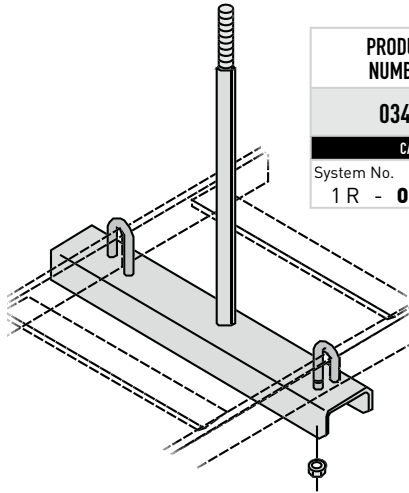

PRODUCT NUMBER	FASTENERS INCLUDED
0345	ZN
CATALOG NUMBERING EXAMPLE:	
System No.	W Fasteners Coating
1 R - 0345 - 12 - ZN - BK	

TRAPEZE SUPPORT KIT

Supports cable runway from the ceiling with threaded rods. Kit includes one ceiling support bracket, one runway side rail support bracket and hex nuts. Threaded rod is purchased separately.

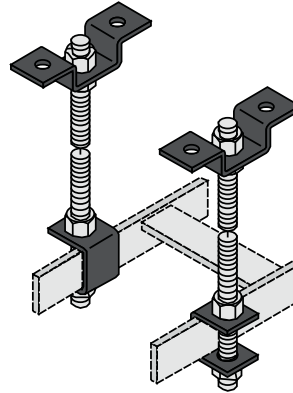

PRODUCT NUMBER	ROD SIZE	FASTENERS INCLUDED
0327	3/8	ZN
0328	1/2	ZN
0331	5/8	ZN
CATALOG NUMBERING EXAMPLE:		
System No.	Fasteners Coating	
1 R - 0327 - ZN - BK		

RUNWAY SUPPORT BRACKETS

Used in conjunction with threaded rod to support cable runway from ceiling. Sold individually. Hardware is purchased separately.

CEILING SUPPORT BRACKET

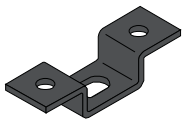

PRODUCT NUMBER	USE WITH FASTENERS
A823-01	3/8
A824-01	1/2 or 5/8
CATALOG NUMBERING EXAMPLE:	
System No.	Coating
R - A823-01 - BK	

SIDE RAIL SUPPORT BRACKET

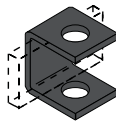

PRODUCT NUMBER	USE WITH FASTENERS
A838-01	3/8
A839-01	1/2 or 5/8
CATALOG NUMBERING EXAMPLE:	
System No.	Coating
1 R - A839-01 - BK	

SLOTTED SUPPORT BRACKET

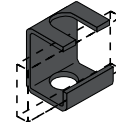

PRODUCT NUMBER	USE WITH FASTENERS
A842-01	3/8
A843-01	1/2
A844-01	5/8
CATALOG NUMBERING EXAMPLE:	
System No.	Coating
1 R - A842-01 - BK	

WIDTHS (W) INCHES

6 | 9 | 12 | 18 | 24

RUNWAY PREFIX OPTIONS

R	ALL SIZES
1R	1 1/2" SIDERAIL (8104, 8106)
2R	2" SIDERAIL (8204, 8206)

COLOR COATING CHART

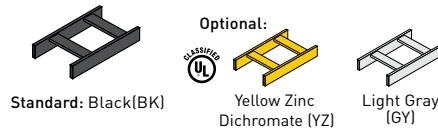

Wall Angle Support, Center Hung Support and Wall Bracket are also available in black and grey colors.





TROUGH TRAY

TABLE OF CONTENTS

INTRODUCTION
PAGES C.1-C.5

TRAY, SPLICING & FITTINGS
PAGES C.6-C.15

SUPPORTS & ACCESSORIES
PAGES C.16-C.25

INSTALLATIONS
PAGES C.26-C.29

SPECIFICATIONS
PAGES C.30-C.31

CROSS REFERENCE
PAGES C.32-C.33

CABLOFIL TROUGH TRAY

Quality Makes the Difference

Legrand continues to be an innovator in cable management solutions and is proud to introduce Cablofil Trough Tray, a cable management system designed to maximize network reliability and minimize lifecycle costs. Our **Fiber Trough** design utilizes high strength steel components to provide the strength and durability required to manage fiber optic or copper cabling in the most demanding data center environments. **V-Trough** provides protection for power cables, keeping them cool and accessible.

Cablofil trough trays are manufactured to exacting standards so that all components fit together perfectly and install with ease. The design includes rolled top edges to add strength and allows the covers to snap in place. It eliminates sharp top edges to keep installers and cables safe. Patented fast splices, bends and turns are available as stocked items. Jobsite fabrication is kept to a minimum and requires little training for most installers, moving on and off the project quickly.

Cablofil trough tray gives any installation a professional look with finishes and colors to match the environment. It is the ultimate protection for your cables.



V-TROUGH VENTILATED TRAY

Keep Your Cables **Out of Sight** and **Secure**

V-Trough cable tray keeps cabling cool, protected and easy to manage. Its high-strength steel construction matches many European OEM specifications and is available in smaller sizes for control and instrumentation cabling. The open tray design allows ready access to cables and additional cabling can be added with ease. Covers are available for complete security. V-Trough is manufactured to exacting standards so that all components fit together perfectly, making installation a snap.



Ventilated Design All V-Trough straight sections are ventilated to reduce cable bundle heating, and to keep mold and moisture from building up within the cable pathway.

Safe and Strong All steel construction provide the ultimate protection to cable bundles. All edges are rounded and eased in the fabrication process to keep cable insulation undamaged during installation.

Access and Security The V-Trough line includes solid covers for all straight and curved sections. Tool-less cover removal allows easy cable access for future cable additions and maintenance. They can also be bolted in place for security.

FIBER TROUGH CABLE TRAY

The **Steel** Alternative

Fiber Trough is designed to maximize network reliability and minimize lifecycle costs. It utilizes high strength steel components to provide the strength and durability required to manage fiber cabling in the most demanding data center environments. It provides the ultimate in protection and is manufactured to exacting standards so that all components fit perfectly and install with ease.

STEEL vs. PLASTIC

Steel Lasts Most cable routing systems manufactured from molded plastic can sag, lose their shape, discolor and even degrade due to exposure to UV light and other environmental conditions. Steel retains its color and shape over time regardless of the application or environment.

Steel tray requires fewer supports Plastic is generally heavier and requires more supports on longer runs. Steel is lighter and more rigid reducing deflection. On longer runs Fiber Trough requires one-half as many supports, reducing installation time overall.

Protection from EMI EMI from transformers or high voltage cables can cause signal interference for copper data cables. Fiber Trough's steel construction can be properly earthed to eliminate EMI and reduce noise and attenuation.



CABLOFIL TROUGH TRAY

The Simple **Difference**

Fluid Design The built-in radius of Cablofil Trough tray effectively eliminates any sharp angles and bends in the cable pathway that cause pinching and micro crack stresses in fiber optic cabling. Its one-piece design integrates the side rails and bottom for a cable pathway that eliminates cable snagging. The end result is a simple and elegant finished installation.

Precision Fit Trough tray's all steel construction allows it to be manufactured to precise standards so that tray sections easily fit together and covers slide in place with ease during the installation process. Cablofil trough tray includes all bends and turns needed for any installation application.

Cable Protection All steel construction provides the ultimate protection for fragile fiber optic and copper cables. It keeps cables safe from cuts, crushing problems and improper bend radius issues. All edges are rounded and eased in the fabrication process to ensure the cable insulation and installer is kept safe during installation.

Splicing Made Simple Patented fast splice accessories are available with pre-fitted screws to speed installation time. The bolts are held in place by the splice, just tighten the nuts to secure tray sections. Simplify your BOM by eliminating the need to plan/order/install fittings. All you need is number of tray, number of FTUS and you are done!

Designed for Installation Ease Easy installation means lower costs. Cablofil Trough Tray installs with few parts and it is easily installed using standard construction practices and common tools.

Complete Line of Accessories All bends and turns necessary for any installation are available as stocked items. No jobsite fabrication will be needed. Other accessories include cable drops, size reductions, cabinet connections and supports.

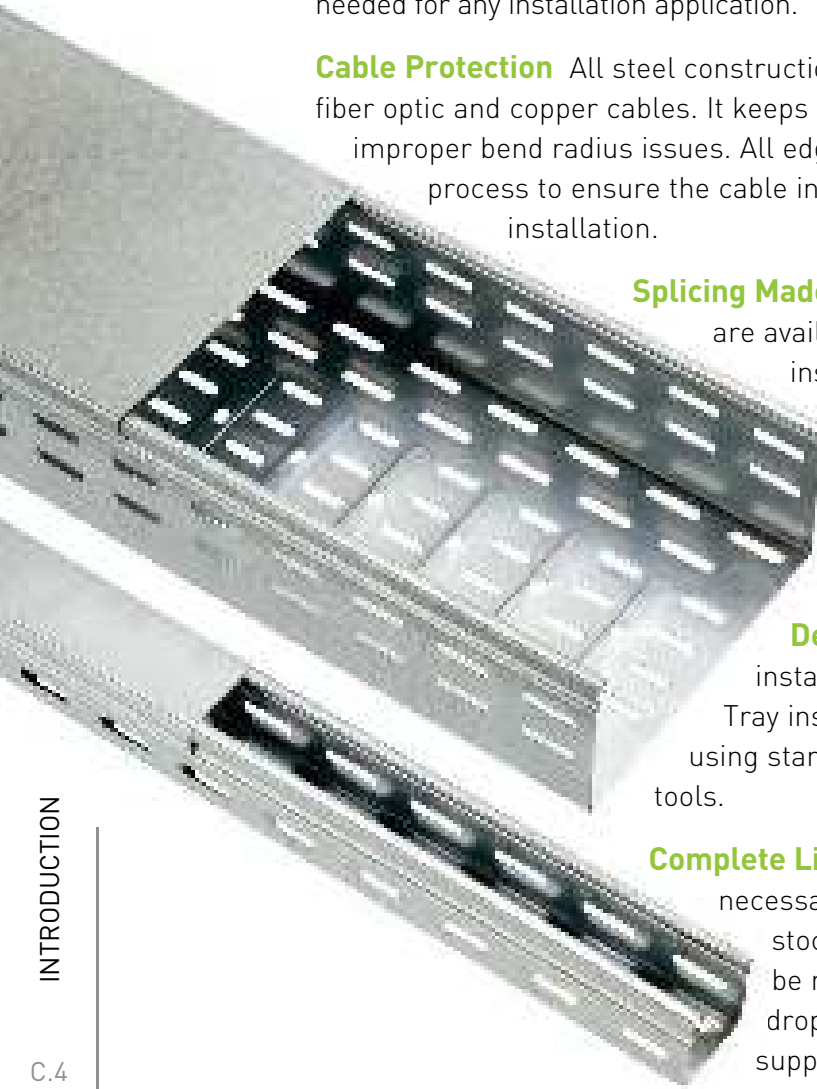

Easy Splicing

Our new splice design is more adaptable than anything on the market – angles, bends, tees and reductions – this splice does it all. The FTUS eliminates the need to plan, order and install special fittings and simplifies your bill of materials. And field modifications are simple when installing Cablofil Trough Tray. It's available in two sizes to fit your tray depth.



Finishes that Last

Cablofil trough tray is stocked in durable pre-galvanized and textured flat black powder coat finishes that resist corrosion over the lifetime of the installation. A white powder coat finish is optional (contact Cablofil for availability.)

FINISHES

STANDARD	PG	Carbon Steel ASTM A510 Grade 1008	Pre-Galvanized: Continuous Galvanization Before Fabrication ASTM A 653
	BL	Carbon Steel ASTM A510 Grade 1008	Black Painted: Black Powder Coated ASTM D 3451
OPTIONAL	WH	Carbon Steel ASTM A510 Grade 1008	White Painted: White Powder Coated ASTM D 3451



TRAY, SPLICING & FITTINGS

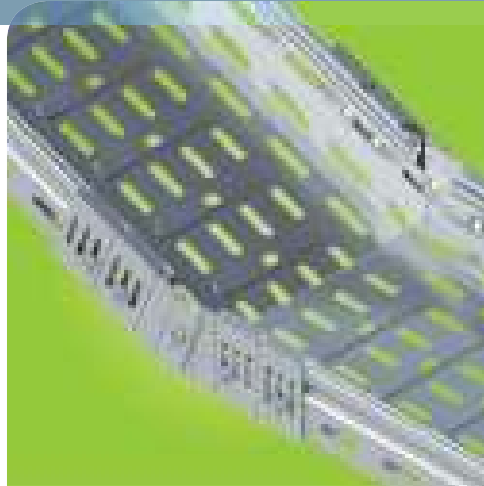

- C.8 FT**
STRAIGHT SECTION TRAY
- C.9 VT**
VENTILATED STRAIGHT SECTION TRAY
- C.8, 9 FTC**
STRAIGHT TRAY COVERS
- C.10 FTUS**
UNIVERSAL ADJUSTABLE SPLICE
- C.11 FTRHR**
RIGHT-HAND REDUCER
- C.11 FTLHR**
LEFT-HAND REDUCER
- C.11 FTEF**
FAS SPLICE
- C.12 FTFB90**
HORIZONTAL 90° ELBOW
- C.12 FTCFB90**
HORIZONTAL 90° ELBOW COVER
- C.12 FTFB45**
HORIZONTAL 45° ELBOW
- C.12 FTCFB45**
HORIZONTAL 45° ELBOW COVER
- C.13 FTVI90**
VERTICAL 90° INSIDE ELBOW
- C.13 FTCVI90**
VERTICAL 90° INSIDE ELBOW COVER
- C.13 FTVO90**
VERTICAL 90° OUTSIDE ELBOW
- C.13 FTCVO90**
VERTICAL 90° OUTSIDE ELBOW COVER
- C.14 FTT**
HORIZONTAL TEE
- C.14 FTTC**
HORIZONTAL TEE COVER
- C.14 FTB**
HORIZONTAL BRANCH
- C.14 FTBC**
HORIZONTAL BRANCH COVER
- C.15 FTX**
HORIZONTAL CROSS
- C.15 FTXC**
HORIZONTAL CROSS COVER
- C.15 FTVT**
UPRIGHT DROPOUT TEE (COVER INCLUDED)

- Strong corrosion-resistant steel construction
- Ventilated tray reduces cable heating, mold and moisture buildup
- Rolled edge for cable protection
- 18-22 gage steel (t)
- Unique design allows covers to snap on
- Covers work with both solid and ventilated tray
- Universal splicing system reduces need for formed fittings.



Use these cable fill tables to determine the tray size(s) needed for your installation.

TRAY	DATA CABLE FILL TABLE				MC POWER CABLE FILL TABLE	
	MAX NUMBER OF CABLES PER CODE				MAX NUMBER OF CABLES PER CODE	
	Cat 5e 4-pr Plenum (.17")	Cat 5e 4-pr Non-Plenum (.19")	Cat 6e 4-pr Plenum (.22")	Cat 6a 4-pr Plenum (.35")	2C (12 AWG) THHN TypeMC AlumArmor	3C (12 AWG) THHN TypeMC AlumArmor
50/50 (2x2)	88	71	53	20	11	10
50/100 (2x4)	177	142	106	41	23	21
50/200 (2x8)	355	284	212	83	47	42
50/300 (2x12)	532	426	318	125	71	63
100/100 (4x4)	351	281	209	82	23	21
100/200 (4x8)	703	563	419	165	47	42
100/300 (4x12)	1055	844	629	248	71	63
100/500 (4x20)	1758	1407	1049	414	119	105
100/600 (4x24)	2110	1689	1259	497	143	126

CABLE CAPACITY (BASED ON 40% FILL*)										
TROUGH TRAY SERIES		50/50	50/100	50/200	50/300	100/100	100/200	100/300	100/500	100/600
TRAY SIZE (HxW-IN)		2x2	2x4	2x8	2x12	4x4	4x8	4x12	4x20	4x24
CABLE FILL AREA (IN ²)		3.875	7.75	15.5	23.25	15.5	31	46.5	77.5	93
CABLE TYPE†	AREA	NUMBER OF CABLES								
Fiber - 0.063" (1.6mm)	0.003	517	1033	2067	3100	2067	4133	6200	10333	12400
Fiber - 0.079" (2.0mm)	0.005	310	620	1240	1860	1240	2480	3720	6200	7440
Fiber - 0.118" (3.0mm)	0.011	141	282	564	845	564	1127	1691	2818	3382
Ribbon - 0.205" (5.2mm)	0.033	47	94	188	282	188	376	564	939	1127
Category 5E - 0.17" (4.32mm)	0.023	67	135	270	404	270	539	809	1348	1617
Category 6 - 0.24" (6.1mm)	0.045	34	69	138	207	138	276	413	689	827
Category 6A - 0.30" (7.6mm)	0.071	22	44	87	131	87	175	262	437	524

*40% fill represents the maximum number of cables that can be practically installed (tray is piled to top of siderails with cable due to cable straightness and gaps between cables). Tray dimensions are nominal.

†Typical cable diameters - for exact results, use the installed cable diameter provided by manufacturer



FT
STRAIGHT SECTION TRAY



BASE	HEIGHT (H)		WIDTH (W)		LENGTH		PG	BL	WH
	IN	MM	IN	MM	FT	M			
FT 50/50	2	50	2	50	10	3	340 020	960 000	–
FT 50/100	2	50	4	100	10	3	340 021	960 001	–
FT 50/200†	2	50	8	200	10	3	340 023	960 002	–
FT 50/300†	2	50	12	300	10	3	340 024	960 003	–
FT 100/100	4	100	4	100	10	3	340 030	960 004	–
FT 100/200	4	100	8	200	10	3	340 032	960 005	–
FT 100/300	4	100	12	300	10	3	340 033	960 006	–
FT 100/500†	4	100	20	500	10	3	340 093	960 007	–
FT 100/600†	4	100	24	600	10	3	340 107	960 008	–

– Contact manufacturer for availability.
† Ribbed bottom for additional rigidity

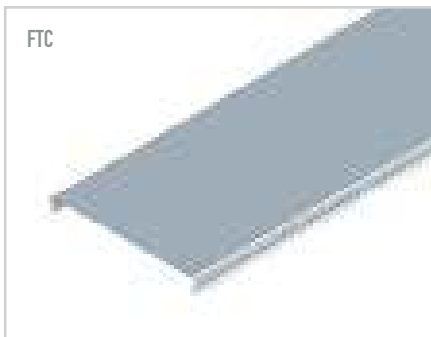
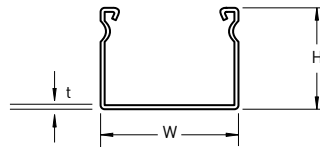

COVER	WIDTH (W)		LENGTH		PG	BL	WH
	IN	MM	FT	M			
FTC 50	2	50	10	3	340 189	960 009	–
FTC 100	4	100	10	3	340 191	960 010	–
FTC 200	8	200	10	3	340 193	960 011	–
FTC 300	12	300	10	3	340 194	960 012	–
FTC 500	20	500	10	3	340 196	960 013	–
FTC 600	24	600	10	3	340 197	960 014	–

– Contact manufacturer for availability.

- 18 gage steel
- All covers are solid. Ventilated covers are not available.
- Splicing sold separately.

VT VENTILATED STRAIGHT SECTION TRAY



BASE	HEIGHT (H)		WIDTH (W)		LENGTH		PG	BL	WH
	IN	MM	IN	MM	FT	M			
VT 50/50	2	50	2	50	10	3	340 052	–	–
VT 50/100	2	50	4	100	10	3	340 053	–	–
VT 50/200†	2	50	8	200	10	3	340 055	–	–
VT 50/300†	2	50	12	300	10	3	340 056	–	–
VT 100/100	4	100	4	100	10	3	340 069	–	–
VT 100/200	4	100	8	200	10	3	340 070	–	–
VT 100/300	4	100	12	300	10	3	340 071	–	–
VT 100/500†	4	100	20	500	10	3	340 073	–	–
VT 100/600†	4	100	24	600	10	3	340 106	–	–

– Contact manufacturer for availability.

† Ribbed bottom for additional rigidity

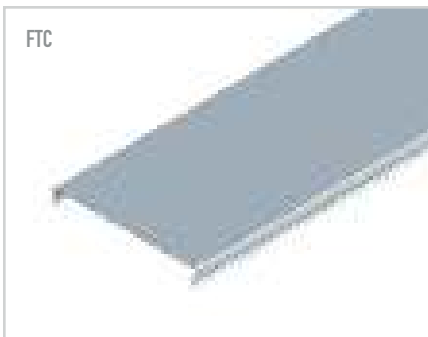
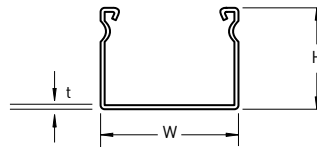

COVER	WIDTH (W)		LENGTH		PG	BL	WH
	IN	MM	FT	M			
FTC 50	2	50	10	3	340 189	960 009	–
FTC 100	4	100	10	3	340 191	960 010	–
FTC 200	8	200	10	3	340 193	960 011	–
FTC 300	12	300	10	3	340 194	960 012	–
FTC 500	20	500	10	3	340 196	960 013	–
FTC 600	24	600	10	3	340 197	960 014	–

– Contact manufacturer for availability.

- 18 gage steel
- All covers are solid. Ventilated covers are not available.
- Splicing sold separately.



FTUS
UNIVERSAL ADJUSTABLE SPLICE

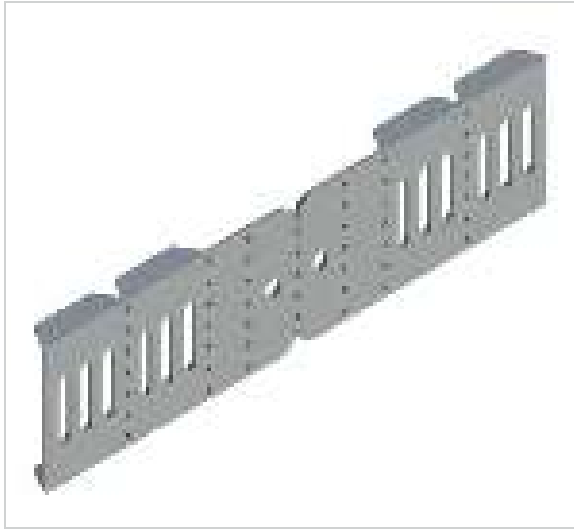

- Eliminates the need for specialized fittings
- One splice performs many functions
- Fabricates tees, reductions and level changes on-site
- Field bend to create one-sided reduction/expansion of 2", 4", 6", or 8"
- Field snap apart to make vertical adjustment splice plate
- ¼" hardware included for adjustable splice plate

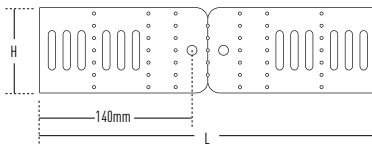

	PACK	HEIGHT (H)		LENGTH (L)		WEIGHT		PG	BL	WH
		PCS	IN	MM	IN	MM	LBS			
FTUS 50	1	2.1	52	11.8	300	2	50	341 224	960 020	-
FTUS 100	1	4.1	104	11.8	300	4	100	341 226	900 021	-

- Contact manufacturer for availability.

APPLICATIONS

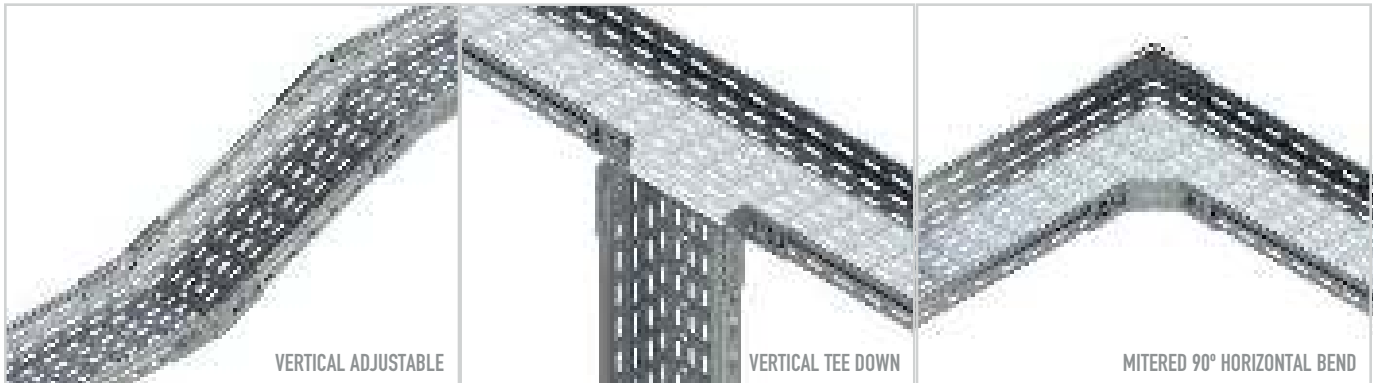

SPLACING

C.10



FTEF FAS SPLICE



FTEF 50



FTEF 100

- Connects straight sections and fittings
- Captive hardware makes installation simple (included)

	PACK		HEIGHT		PG
	PCS		IN	MM	
FTEF 50	1		2.0	50	341 563
FTEF 100	1		4.0	100	341 622

FTRHR RIGHT-HAND REDUCER

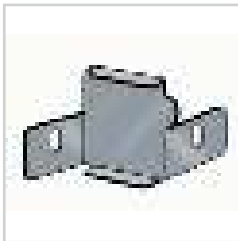

- Rigid steel construction
- Connects straight sections and fittings of different widths
- Hardware included

	PACK		HEIGHT		REDUCTION		PG	BL	WH
	PCS		IN	MM	IN	MM			
FTRHR 50/25	1		2.0	50	1.0	25	341 550	960 148	–
FTRHR 50/50	1		2.0	50	2.0	50	341 551	341 551	–
FTRHR 50/100	1		2.0	50	4.0	100	341 552	960 150	–
FTRHR 50/150	1		2.0	50	6.0	150	341 553	960 151	–
FTRHR 50/200	1		2.0	50	8.0	200	341 554	960 152	–
FTRHR 100/50	1		4.0	100	2.0	50	341 669	960 164	–
FTRHR 100/100	1		4.0	100	4.0	100	341 670	960 165	–
FTRHR 100/150	1		4.0	100	6.0	150	341 671	960 166	–

– Contact manufacturer for availability.

FTLHR LEFT-HAND REDUCER

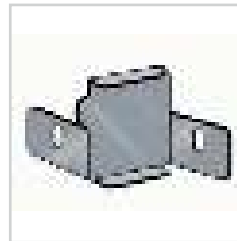

- Rigid steel construction
- Connects straight sections and fittings of different widths
- Hardware included

	PACK		HEIGHT		REDUCTION		PG	BL	WH
	PCS		IN	MM	IN	MM			
FTLHR 50/25	1		2.0	50	1.0	25	341 577	960 153	*
FTLHR 50/50	1		2.0	50	2.0	50	341 578	960 154	*
FTLHR 50/100	1		2.0	50	4.0	100	341 579	960 155	*
FTLHR 50/150	1		2.0	50	6.0	150	341 580	960 156	*
FTLHR 50/200	1		2.0	50	8.0	200	341 581	960 157	*
FTLHR 100/50	1		4.0	100	2.0	50	341 691	960 167	*
FTLHR 100/100	1		4.0	100	4.0	100	341 692	960 168	*
FTLHR 100/150	1		4.0	100	6.0	150	341 693	960 169	*

– Contact manufacturer for availability.

APPLICATIONS

Example of assembly for a right-hand ①, left-hand ② and concentric ③ reduction.

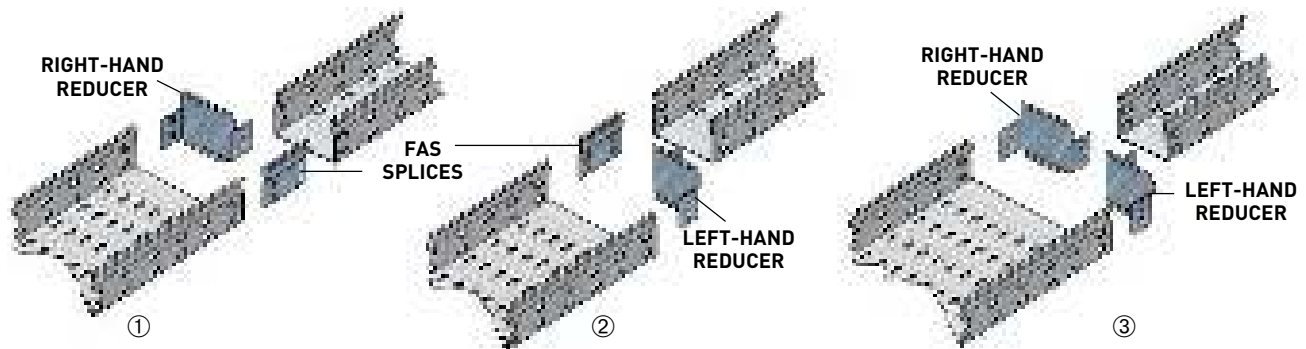

FTFB90
HORIZONTAL 90° ELBOW

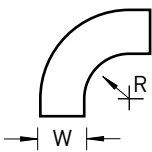

- All fittings and covers are solid.
- Cover sold separately.

BASE	HEIGHT		WIDTH (W)		RADIUS (R)		PG	BL	WH
	IN	MM	IN	MM	IN	MM			
FTFB90 50/50	2	50	2	50	4	100	340 914	960 022	–
FTFB90 50/100	2	50	4	100	4	100	340 915	960 023	–
FTFB90 50/200	2	50	8	200	4	100	340 917	960 024	–
FTFB90 50/300	2	50	12	300	4	100	340 918	960 025	–
FTFB90 100/100	4	100	4	100	9.6	244	340 930	960 026	–
FTFB90 100/200	4	100	8	200	9.6	244	340 932	960 027	–
FTFB90 100/300	4	100	12	300	9.6	244	340 933	960 028	–
FTFB90 100/500	4	100	20	500	9.6	244	340 935	960 029	–
FTFB90 100/600	4	100	24	600	9.6	244	341 936	960 030	–

COVER	WIDTH		PG	BL	WH
	IN	MM			
FTFCB90 50	2	50	340 861	960 094	–
FTFCB90 100	4	100	340 863	960 095	–
FTFCB90 200	8	200	340 865	960 096	–
FTFCB90 300	12	300	340 866	960 097	–
FTFCB90 500	20	500	340 868	960 098	–
FTFCB90 600	24	600	340 869	960 099	–

– Contact manufacturer for availability.

FTFB45
HORIZONTAL 45° ELBOW

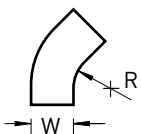

- All fittings and covers are solid.
- Cover sold separately.

BASE	HEIGHT		WIDTH (W)		RADIUS		PG	BL	WH
	IN	MM	IN	MM	IN	MM			
FTFB45 50/50	2	50	2	50	0.8	20	340 944	960 031	–
FTFB45 50/100	2	50	4	100	4	100	340 945	960 032	–
FTFB45 50/200	2	50	8	200	4	100	340 947	960 033	–
FTFB45 50/300	2	50	12	300	4	100	340 948	960 034	–
FTFB45 100/100	4	100	4	100	4	100	340 960	960 035	–
FTFB45 100/200	4	100	8	200	4	100	340 962	960 036	–
FTFB45 100/300	4	100	12	300	4	100	340 963	960 037	–
FTFB45 100/500	4	100	20	500	6	150	340 965	960 038	–
FTFB45 100/600	4	100	24	600	6	150	350 512	960 039	–

COVER	WIDTH		PG	BL	WH
	IN	MM			
FTFCB45 50	2	50	340 870	960 100	–
FTFCB45 100	4	100	340 872	960 101	–
FTFCB45 200	8	200	340 874	960 102	–
FTFCB45 300	12	300	340 875	960 103	–
FTFCB45 500	20	500	340 877	960 104	–
FTFCB45 600	24	600	340 878	960 105	–

– Contact manufacturer for availability.



FTVI90
VERTICAL 90° INSIDE ELBOW

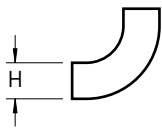
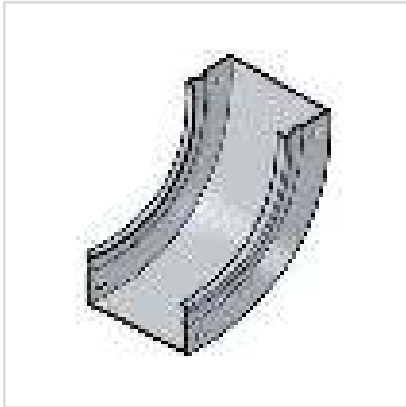

- All fittings and covers are solid.
- Cover sold separately.

BASE	HEIGHT (H)		WIDTH		PG	BL	WH
	IN	MM	IN	MM			
FTVI90 50/50	2	50	2	50	340 979	960 040	–
FTVI90 50/100	2	50	4	100	340 980	960 041	–
FTVI90 50/200	2	50	8	200	340 982	960 042	–
FTVI90 50/300	2	50	12	300	340 983	960 043	–
FTVI90 100/100	4	100	4	100	340 995	960 044	–
FTVI90 100/200	4	100	8	200	340 997	960 045	–
FTVI90 100/300	4	100	12	300	340 998	960 046	–
FTVI90 100/500	4	100	20	500	341 000	960 047	–
FTVI90 100/600	4	100	24	600	341 101	960 048	–

COVER	FITS TRAY HEIGHT		WIDTH		PG	BL	WH
	IN	MM	IN	MM			
FTCVI90 50/50	2	50	2	50	340 888	960 112	–
FTCVI90 50/100	2	50	4	100	340 890	960 113	–
FTCVI90 50/200	2	50	8	200	340 892	960 114	–
FTCVI90 50/300	2	50	12	300	340 893	960 115	–
FTCVI90 100/100	4	100	4	100	341 175	960 116	–
FTCVI90 100/200	4	100	8	200	340 894	960 117	–
FTCVI90 100/300	4	100	12	300	340 895	960 118	–
FTCVI90 100/500	4	100	20	500	340 897	960 119	–
FTCVI90 100/600	4	100	24	600	340 898	960 120	–

– Contact manufacturer for availability.

FTV090
VERTICAL 90° OUTSIDE ELBOW

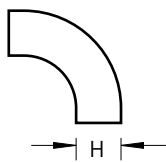

- All fittings and covers are solid.
- Cover sold separately.

BASE	HEIGHT (H)		WIDTH		PG	BL	WH
	IN	MM	IN	MM			
FTV090 50/50	2	50	2	50	341 038	960 049	–
FTV090 50/100	2	50	4	100	341 039	960 050	–
FTV090 50/200	2	50	8	200	341 041	960 051	–
FTV090 50/300	2	50	12	300	341 042	960 052	–
FTV090 100/100	4	100	4	100	341 054	960 053	–
FTV090 100/200	4	100	8	200	341 056	960 054	–
FTV090 100/300	4	100	12	300	341 057	960 055	–
FTV090 100/500	4	100	20	500	341 059	960 056	–
FTV090 100/600	4	100	24	600	341 007	960 057	–

COVER	FITS TRAY HEIGHT		WIDTH		PG	BL	WH
	IN	MM	IN	MM			
FTCV090 50/50	2	50	2	50	340 798	960 133	–
FTCV090 50/100	2	50	4	100	340 808	960 134	–
FTCV090 50/200	2	50	8	200	340 818	960 135	–
FTCV090 50/300	2	50	12	300	340 819	960 136	–
FTCV090 100/100	4	100	4	100	340 181	960 137	–
FTCV090 100/200	4	100	8	200	340 825	960 138	–
FTCV090 100/300	4	100	12	300	340 826	960 139	–
FTCV090 100/400	4	100	20	500	340 828	960 140	–
FTCV090 100/500	4	100	24	600	340 829	960 141	–

– Contact manufacturer for availability.



**FTT
HORIZONTAL TEE**

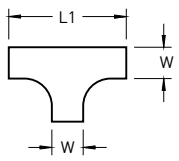
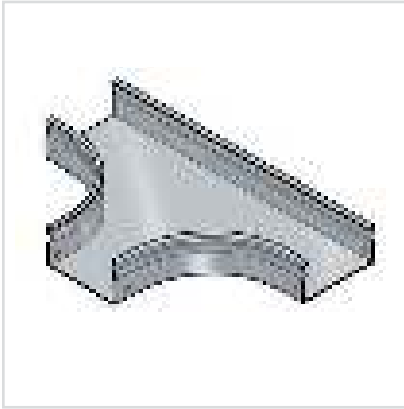

- All fittings and covers are solid.
- Cover sold separately.

BASE	HEIGHT		WIDTH (W)		LENGTH (L1)		PG	BL	WH
	IN	MM	IN	MM	IN	MM			
FTT 50/50	2	50	2	50	6	150	341 103	960 058	–
FTT 50/100	2	50	4	100	14	360	341 104	960 059	–
FTT 50/200	2	50	8	200	18	460	341 106	960 060	–
FTT 50/300	2	50	12	300	22	560	341 107	960 061	–
FTT 100/100	4	100	4	100	14	360	341 119	960 062	–
FTT 100/200	4	100	8	200	18	460	341 121	960 063	–
FTT 100/300	4	100	12	300	22	560	341 122	960 064	–
FTT 100/400	4	100	20	500	36	900	341 124	960 065	–
FTT 100/500	4	100	24	600	40	1000	341 008	960 066	–

COVER	WIDTH		PG	BL	WH
	IN	MM			
FTTC 50	2	50	340 879	960 106	–
FTTC 100	4	100	340 881	960 107	–
FTTC 200	8	200	340 883	960 108	–
FTTC 300	12	300	340 884	960 109	–
FTTC 500	20	500	340 886	960 110	–
FTTC 600	24	600	340 887	960 111	–

– Contact manufacturer for availability.

**FTB
HORIZONTAL BRANCH**

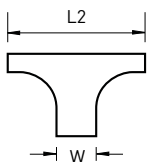

- All fittings and covers are solid.
- Cover sold separately.

BASE	HEIGHT		WIDTH (W)		LENGTH (L2)		PG	BL	WH
	IN	MM	IN	MM	IN	MM			
FTB 50/50	2	50	2	50	6	150	340 129	960 067	–
FTB 50/100	2	50	4	100	14	360	340 131	960 068	–
FTB 50/200	2	50	8	200	18	460	340 133	960 069	–
FTB 50/300	2	50	12	300	22	560	340 134	960 070	–
FTB 100/100	4	100	4	100	14	360	340 439	960 071	–
FTB 100/200	4	100	8	200	18	460	340 445	960 072	–
FTB 100/300	4	100	12	300	22	560	340 446	960 073	–
FTB 100/500	4	100	20	500	36	900	340 499	960 074	–
FTB 100/600	4	100	24	600	40	1000	340 500	960 075	–

COVER	WIDTH		PG	BL	WH
	IN	MM			
FTBC 50	2	50	340 501	960 121	–
FTBC 100	4	100	340 503	960 122	–
FTBC 200	8	200	340 505	960 123	–
FTBC 300	12	300	340 728	960 124	–
FTBC 500	20	500	340 746	960 125	–
FTBC 600	24	600	340 747	960 126	–

– Contact manufacturer for availability.



FTX HORIZONTAL CROSS

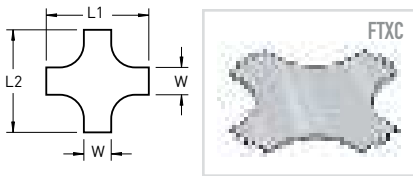
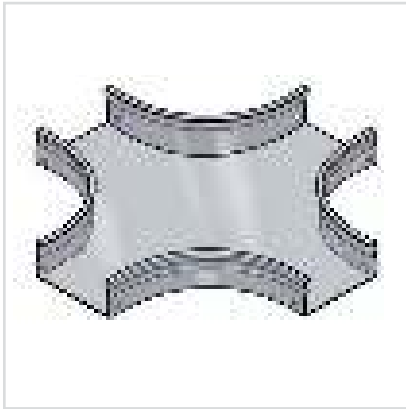

- All fittings and covers are solid.
- Cover sold separately.

BASE	HEIGHT		WIDTH (W)		LENGTH (L1/L2)		PG	BL	WH
	IN	MM	IN	MM	IN	MM			
FTX 50/50	2	50	2	50	6	150	341 133	960 076	–
FTX 50/100	2	50	4	100	14	360	341 134	960 077	–
FTX 50/200	2	50	8	200	18	460	341 136	960 078	–
FTX 50/300	2	50	12	300	22	560	341 137	960 079	–
FTX 100/100	4	100	4	100	14	360	341 149	960 080	–
FTX 100/200	4	100	8	200	18	460	341 151	960 081	–
FTX 100/300	4	100	12	300	22	560	341 152	960 082	–
FTX 100/500	4	100	20	500	36	900	341 154	960 083	–
FTX 100/600	4	100	24	600	40	1000	341 067	960 084	–

COVER	WIDTH		PG	BL	WH
	IN	MM			
FTXC 50	2	50	340 748	960 127	–
FTXC 100	4	100	340 758	960 128	–
FTXC 200	8	200	340 768	960 129	–
FTXC 300	12	300	340 769	960 130	–
FTXC 500	20	500	340 779	960 131	–
FTXC 600	24	600	340 788	960 132	–

– Contact manufacturer for availability.

FTVT UPRIGHT DROPOUT TEE

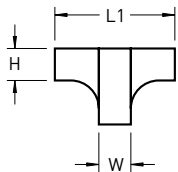

- All fittings and covers are solid.
- Full access allows cable lay-in.
- Covers included.

BASE + COVER	HEIGHT (H)		WIDTH (W)		LENGTH (L1)		PG	BL	WH
	IN	MM	IN	MM	IN	MM			
FTVT 50/50	2	50	2	50	6	150	340 662	960 085	–
FTVT 50/100	2	50	4	100	14	360	340 663	960 086	–
FTVT 50/200	2	50	8	200	18	460	340 665	960 087	–
FTVT 50/300	2	50	12	300	22	560	340 666	960 088	–
FTVT 100/100	4	100	4	100	14	360	340 678	960 089	–
FTVT 100/200	4	100	8	200	18	460	340 680	960 090	–
FTVT 100/300	4	100	12	300	22	560	340 681	960 091	–
FTVT 100/500	4	100	20	500	36	900	340 683	960 092	–

– Contact manufacturer for availability.



SUPPORTS & ACCESSORIES



- C.17 FTCH**
CENTER HANGER
- C.17 FTCHC**
CENTER HANGER
- C.17 FTAS**
TRAPEZE HANGING CLIP
- C.18 CS**
STANDARD L BRACKET
- C.18 CSC**
STANDARD C BRACKET
- C.18 PROCS**
STANDARD PROFILE
- C.18 A838/A839**
SIDE RAIL SUPPORT BRACKETS
- C.18 FTRB**
ROD BRACKET KIT
- C.19 FAS U**
UNIVERSAL BRACKET
- C.19 EDF**
RAIL
- C.20 PFREDF**
CEILING MOUNTING BRACKET
- C.20 ERD 10**
BRACE PLATE
- C.20 DF**
FLOOR SUPPORT BRACKET
- C.21 FTCFCL**
COVER FASTENING CLIP
- C.21 FTFCL**
FASTENING CLIP
- C.21 FTHDCL**
TRAY HOLD DOWN CLIP
- C.22 FTUMP**
UNIVERSAL ACCESSORY
MOUNTING PLATE
- C.22 FTCC**
CABINET CONNECTION

- C.22 FTCF**
CABINET CONNECTION FLANGE
- C.23 COT 54/105**
DIVIDER STRIP
- C.23 COT J**
DIVIDER COUPLER
- C.24 JP**
EDGE PROTECTION STRIP
- C.24 FTBP**
BOTTOM ALIGNMENT PLATE
- C.24 FTP31CL**
P31 MARKING CLIP
- C.24 FTBE**
BLIND END
- C.25 BTRCC6X12**
- C.25 CA**
- C.25 ECLI**
- C.25 EZ BN**
- C.25 EZ CN**
- C.25 EZ FW**
- C.25 EZ HN**
- C.25 THRD**
- C.25 THRDPT**



FTCH CENTER HANGER



- Secure to tray by bending tabs outward
- Use with tray runs without covers
- Order to fit width of tray
- Designed for 3/8" threaded rod

	PACK		WIDTH		WEIGHT		MAX LOAD		PG
	PCS		IN	MM	LBS	KG	LBS	N	
FTCH 100	1		4.0	100	-	-	337	1500	341 164
FTCH 200	1		8.0	200	-	-	337	1500	341 166
FTCH 300	1		12.0	300	-	-	337	1500	341 167*

*Coming Soon

FTCHC CENTER HANGER



- Open side allows cables to be added to pathway easily
- Works with Fiber Trough or V-Trough Tray up to 16" wide
- Use with 3/8" threaded rod
- Steel construction is available in two finishes (EZ and GC)

	PACK		TRAY WIDTH		HEIGHT		WEIGHT		EZ	GC
	PCS		IN	MM	IN	MM	LBS	KG		
FTCHC75	1		3	75	2.5	63.5	.623	.282	-	343279
FTCHC100	1		4	100	3	76	.694	.314	347280	343280
FTCHC150	1		6	150	4	102	1.38	.629	347281	343281
FTCHC200	1		8	200	5	127	1.63	.739	347282	343282
FTCHC300	1		12	300	7	177	2.65	1.20	347283	343283
FTCHC400	1		16	400	9	230	4.77	2.16	347284	343284

- Contact manufacturer for availability.

FTAS TRAPEZE HANGING CLIP

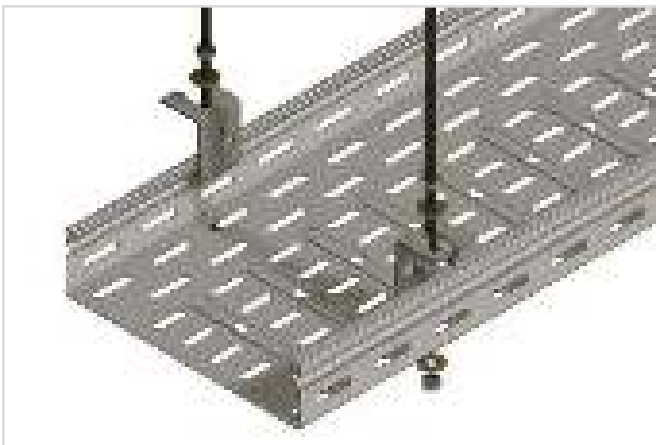

- Secure to tray by bending tabs
- Use with tray runs without covers
- Use for multi-level tray runs
- Use with 1/4" and 3/8" threaded rods

	PACK		WEIGHT		MAX LOAD		PG
	PCS		LBS	KG	LBS	N	
FTAS	1		-	-	562	2500	341 170

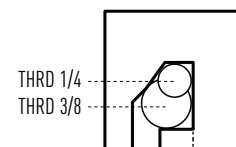

CS STANDARD L BRACKET

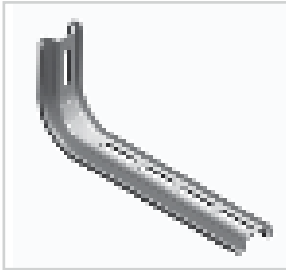

- For cable tray installation onto walls
- ECLI clip prevents bracket compression
- EZ BN 1/4, CE 25 and ECLI are sold separately
- Designed for 1/4" hardware (sold separately)

	WIDTH		LENGTH		PG	BL	WH
	IN	MM	IN	MM			
CS 100	4.0	100	5.7	145	002 700	941 130	–
CS 200	8.0	200	9.6	245	002 710	941 131	–
CS 300	12.0	300	13.6	345	002 720	941 132	–

– Contact manufacturer for availability.

PROCS STANDARD PROFILE

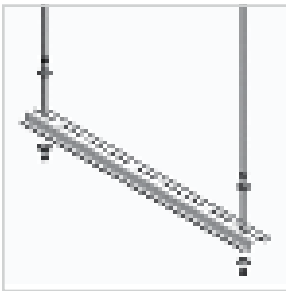

- Field cut to any length
- Can support multiple tray runs
- Threaded rods, nuts, and washers sold separately

	LENGTH		WEIGHT		PG	BL	WH
	IN	MM	LBS	KG			
PROCS 1000	39.0	1000	2.6	1.2	002 920	941 140	–
PROCS 2000	79.0	2000	5.1	2.3	002 930	941 141	–
PROCS 3000	118.0	3000	8.4	3.8	002 940	941 142	–

– Contact manufacturer for availability.

CSC STANDARD C BRACKET

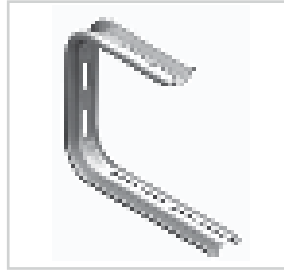

- Can be stacked for multi-level Cablofil tray installations
- ECLI clip prevents bracket compression
- EZ BN 1/4, EZ BN 5/16, CE 25, CE 40 and ECLI are sold separately
- Designed for 1/4" hardware (sold separately)

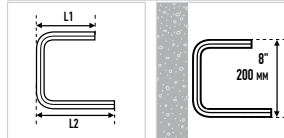

	WIDTH		LENGTH (L1)		LENGTH (L2)		PG	BL	WH
	IN	MM	IN	MM	IN	MM			
CSC 100	4.0	100	5.1	130	5.7	145	002 760	941 136	–
CSC 200	8.0	200	7.0	180	9.6	245	002 770	941 137	–
CSC 300	12.0	300	9.0	230	13.6	345	002 780	941 138	–

– Contact manufacturer for availability.

A838/A839 SIDE RAIL SUPPORT BRACKETS

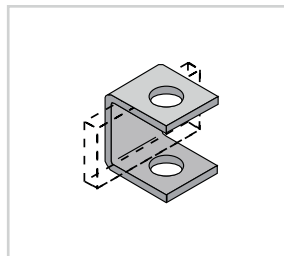

- Used in conjunction with threaded rod to support fiber trough from cable runway. Sold individually.
- Hardware sold separately
- 2" version available upon request

	HEIGHT		USE WITH HARDWARE	PG
	IN	MM		
1R-A838-01	1.0	25.4	3/8"	P250 474
1R-A839-01	1.0	25.4	1/2" or 5/8"	P250 475

FTRB ROD BRACKET KIT

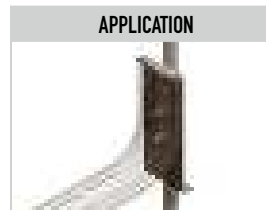

- Quickly and securely attaches to 3/8", 1/2" and 5/8" threaded rods
- Works with existing or new installations
- Allows quick attachment of bracket

	WIDTH		LENGTH		PG
	IN	MM	IN	MM	
FTRB	2	50	4	100	960 178



FAS U UNIVERSAL BRACKET

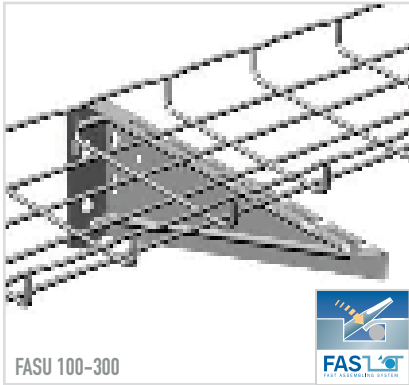

FASU 100-300

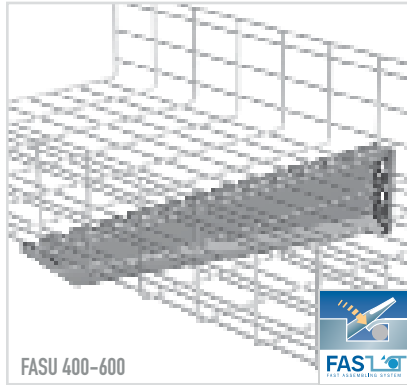

FASU 400-600

- Use for tray support on walls or under floor applications.
- FAS U snaps directly into EDF rail
- Key holes in back of bracket for simple wall mounting with 1/4" hardware

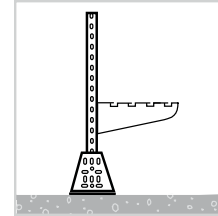

	HEIGHT		TRAY WIDTH		LENGTH		WEIGHT		PG	BL	WH
	IN	MM	IN	MM	IN	MM	LBS	KG			
FASU 100	3.5	85	4.0	100	6.0	157	0.3	0.1	557 410	941 267	—
FASU 200	5.5	139	8.0	200	12.0	257	0.5	0.2	557 430	941 269	—
FASU 300	5.5	139	12.0	300	14.0	357	0.8	0.3	557 440	941 270	—
FASU 500	5.5	137.7	20.0	500	22.0	557	2.9	1.3	557 460	941 272	—
FASU 600	5.5	137.7	24.0	600	26.0	657	6.4	2.9	557 470	941 273	—

– Contact manufacturer for availability.

EDF RAIL

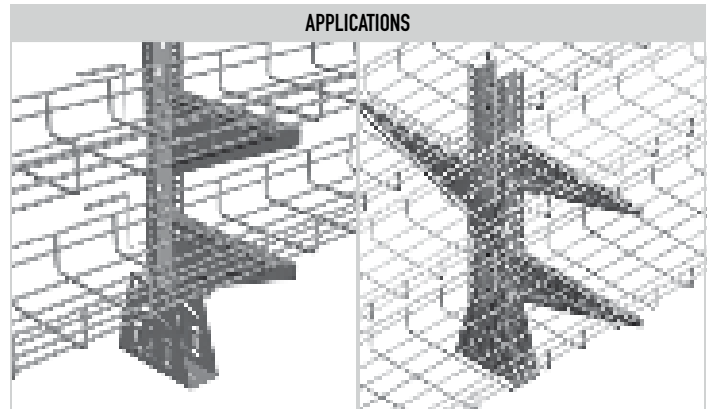
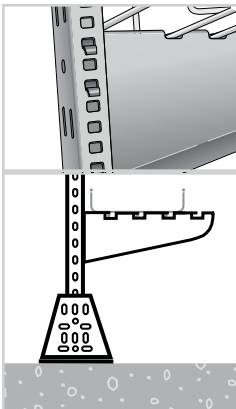
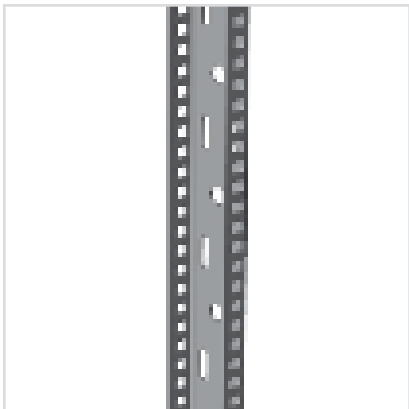

APPLICATIONS

- EDF Rail makes multiple floor mounted cable tray runs easier and faster to install
- CA Pin (sold separately) is required to install 4" to 12" FAS U. Suggested for 16" to 24" FAS U.
- FAS U sizes 16" to 24" will snap directly onto EDF Rail

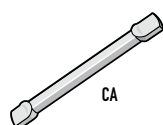
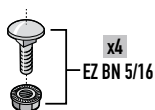

	LENGTH		WEIGHT		PG	BL	WH
	IN	MM	LBS	KG			
EDF 300	10.6	270	0.7	0.3	561 310	942 817	—
EDF 600	24.8	630	1.8	0.8	557 610	942 815	—
EDF 1000	39.0	990	2.6	1.2	561 090	942 813	—
EDF 2000	78.0	2000	5.5	2.5	561 010	941 288	—
EDF 3000	120.0	3000	9.1	4.1	561 020	941 289	—

– Contact manufacturer for availability.



**PFREDF
CEILING MOUNTING BRACKET**

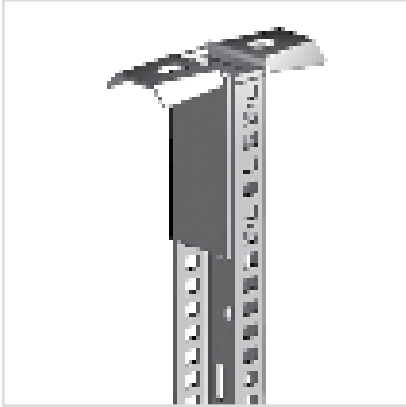

- Use PFREDF to attach EDF Rail directly to ceiling
- EDF Rail attaches to PFREDF without additional hardware

	WEIGHT		LENGTH		PG	BL	WH
	LBS	KG	IN	MM			
PFREDF	1.3	0.6	1.3	0.6	561 080	942 761	–

– Contact manufacturer for availability.

**ERD 10
BRACE PLATE**

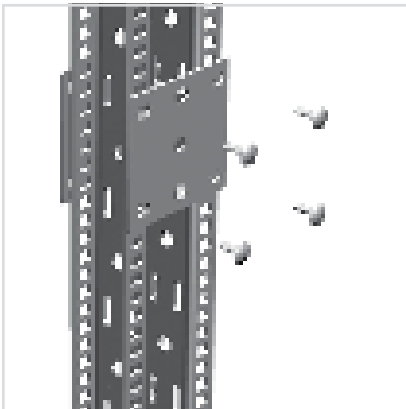

- Use ERD 10 to assemble double-sided ceiling hung tray runs.
- Attach EDF Rail to ERD 10 with EZ BN 5/16 (sold separately).

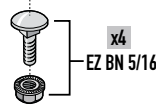

	LENGTH		WEIGHT		PG	BL	WH
	IN	MM	LBS	KG			
ERD 10	0.4	0.5	0.4	0.5	561 050	942 759	–

– Contact manufacturer for availability.

**DF
FLOOR SUPPORT BRACKET**

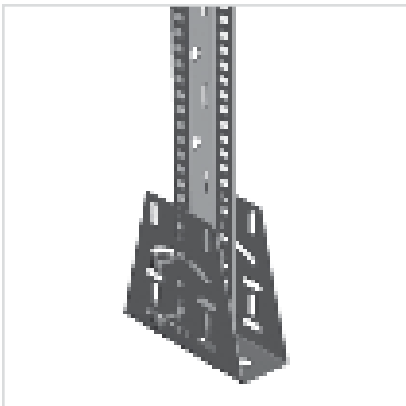

- Use DF to attach EDF Rail to any floor
- Attach EDF Rail to DF with EZBN 5/16 (sold separately)
- Also use DF to attach EDF to a ceiling or deck that is on an angle for a perfect pendant hanger

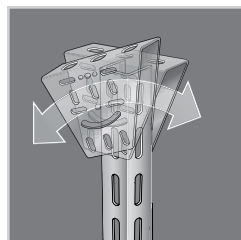

	LENGTH		WEIGHT		PG	BL	WH
	IN	MM	LBS	KG			
DF	1.3	0.6	1.3	0.6	561 060	942 880	–

– Contact manufacturer for availability.

FTCFCL COVER FASTENING CLIP

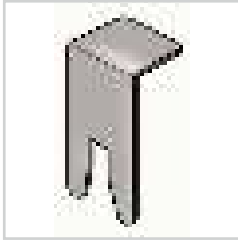

- Provides added cover security
- Utilizes existing splice hardware
- Strong stainless steel construction

	PACK	304L
	PCS	
FTCFCL	50	341 709

APPLICATION

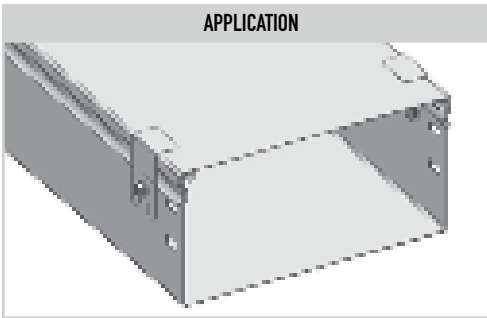

FTFCL FASTENING CLIP



- Strong stainless steel construction
- Snaps on standard C bracket
- Use to secure tray without hardware
- Two required per support

**LEGRAND
PATENTED**

	PACK	316L
	PCS	
FTFCL	1	349 252

APPLICATION



FTHDCL TRAY HOLD DOWN CLIP



- Strong stainless steel construction
- Allows easy cover removal without removing tray hold down
- Two required per support
- Recommended for solid (non-perforated) trays. (FT series tray and all fittings)

**LEGRAND
PATENTED**

APPLICATIONS

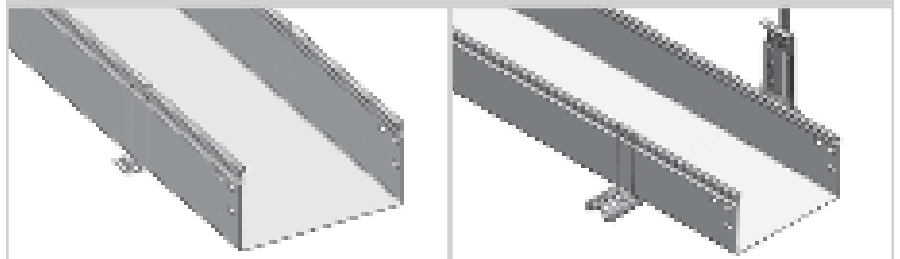

	PACK	FOR HEIGHT		316L
	PCS	IN	MM	
FTHDCL 50	1	2.0	50	349 253
FTHDCL 100	1	4.0	100	349 255



FTUMP UNIVERSAL ACCESSORY MOUNTING PLATE

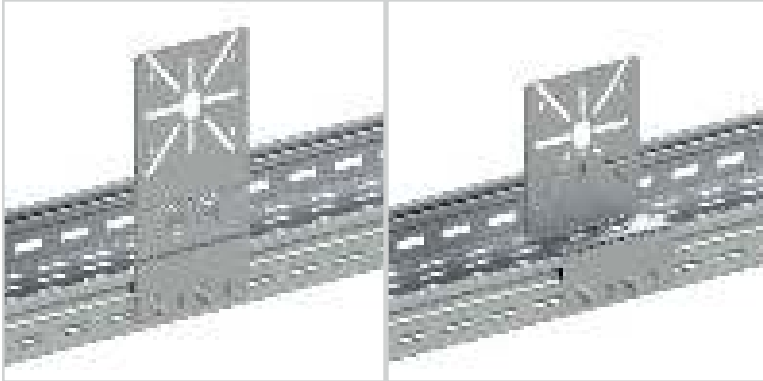

- Attaches to tray side rail with two M6x10 bolts. (Not included)
- Use vertically or bend for horizontal applications
- Use on 2" or 4" deep tray
- Fits all standard steel box sizes

	PACK		HEIGHT		WEIGHT		PG
	PCS		IN	MM	LBS	KG	
FTUMP	1	-	-	-	-	-	350 155*

*Coming Soon

FTCC CABINET CONNECTION



- Quick, clean connection to data cabinet
- Unique steel/plastic combination fits tray widths from 2" to 12" (50-300mm)
- Allows up to 4" flexibility of tray length at termination point
- Flared design allows tray connection when opening is larger than tray width
- Pack contains all pieces for one connection pair

	PACK		HEIGHT		PG
	PCS		IN	MM	
FTCC	1	2.0	50	349 849	

FTCF CABINET CONNECTION FLANGE

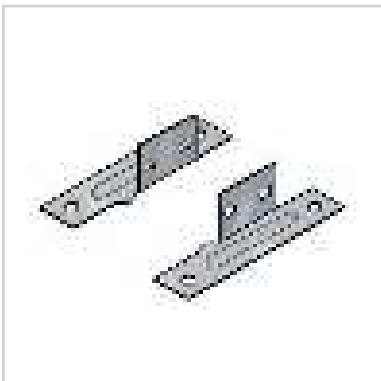

- Rigid steel construction
- Provides secure attachment at tray termination points
- Two connection brackets per package
- Hardware included

	PACK		HEIGHT		PG
	PCS		IN	MM	
FTCF 50	1	2.0	50	341 576	
FTCF 100	1	4.0	100	341 690	

COT 54/105 DIVIDER STRIP

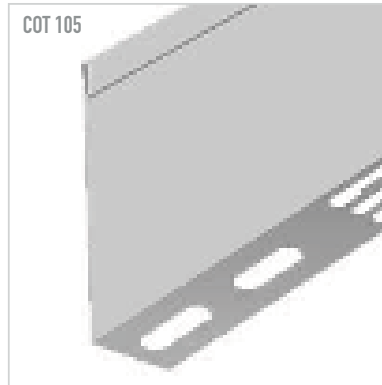
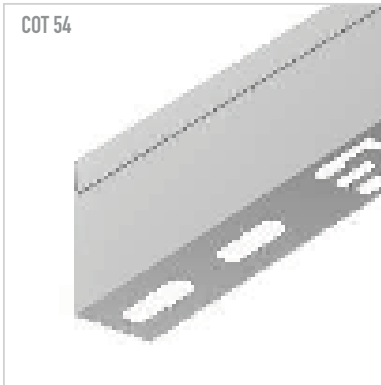

- For cable separation within a single tray.
- Attach to tray with EZBN 1/4.
- Hardware optional and sold separately for COT 54 (see pg. C.25); required and included with COT 105 (as part of kit).
- Field modify with tin snips for changes in levels
- Rolled top edge provides rigidity as well as protection for cables



	HEIGHT		LENGTH		WEIGHT		PG	GC	316L	BL	WH
	IN	MM	FT	M	LBS	KG					
COT 54	2.0	54	10.0	3	2.8	1.3	923 020	923 023	923 024	942 284	–
COT 105 KIT	4.0	105	10.0	3	4.7	2.1	943 413	943 414	943 415	943 416	–

– Contact manufacturer for availability.

COT J DIVIDER COUPLER

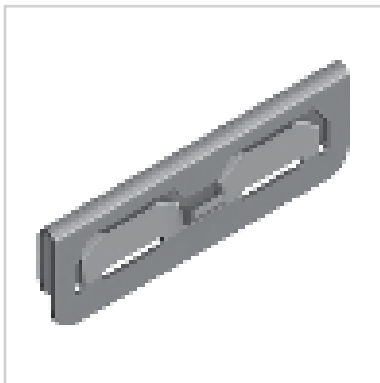

- Improves electrical continuity and strengthens dividers.
- Can be removed with a screwdriver and is reusable.

	PKG. QTY.	WEIGHT		AL	PG	316L
		PCS	LBS			
COT J	1	0.026	0.012	943 390	923 050	923 054



JP EDGE PROTECTION STRIP

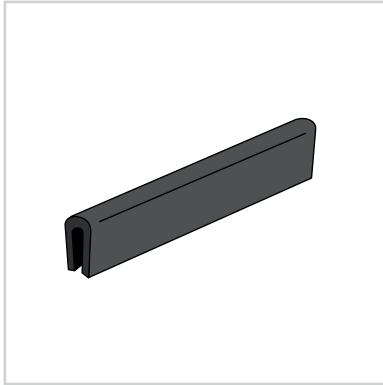

- Slip on edge protection
- Black vinyl
- 15' roll cut to fit

	LENGTH		VINYL
	FT	M	
JP	15.0	1.5	522 354

FTBP BOTTOM ALIGNMENT PLATE

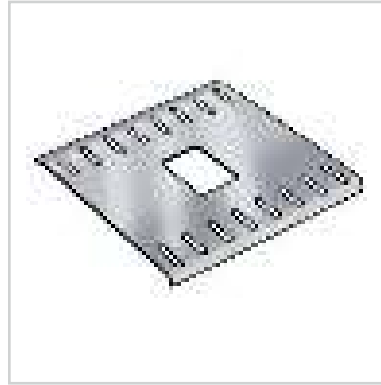

- Helps maintain trough bottom alignment with heavy cable loads
- Includes hardware

	PACK PCS	FITS TRAY WIDTHS		PG
		IN	MM	
FTBP 300	1	4.0-12.0	100-300	341 500
FTBP 600	1	20.0-24.0	500-600	341 503

FTP31CL P31 MARKING CLIP

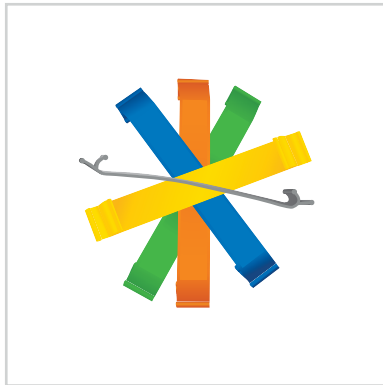

- Snap-in plastic clip
- Writable surface allows easy marking/identification
- PVC construction

	PACK	PLASTIC	COLOR
	PCS		
FTP31CLOR	1	340 184	ORANGE
FTP31CLBL	1	340 185	BLUE
FTP31CLYL	1	340 186	YELLOW
FTP31CLGN	1	340 187	GREEN

FTBE BLIND END

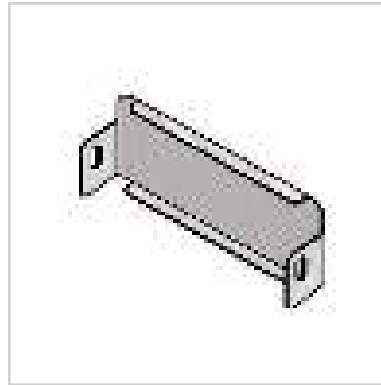

- Can be field punched for conduit attachment
- Rigid steel construction
- Includes hardware

	PACK PCS	HEIGHT		WIDTH		PG
		IN	MM	IN	MM	
FTBE 50/50	1	2.0	50	2.0	50	341 537
FTBE 50/100	1	2.0	50	4.0	100	341 538
FTBE 50/200	1	2.0	50	8.0	200	341 540
FTBE 50/300	1	2.0	50	12.0	300	341 541
FTBE 100/100	1	4.0	100	4.0	100	341 659
FTBE 100/200	1	4.0	100	8.0	200	341 661
FTBE 100/300	1	4.0	100	12.0	300	341 662
FTBE 100/500	1	4.0	100	20.0	500	341 664
FTBE 100/600	1	4.0	100	24.0	600	340 737



BTRCC6X12



CA

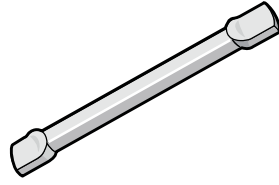

ECLI

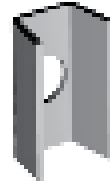

EZ BN



EZ CN



EZ FW

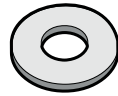

EZ HN

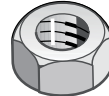

THRD



THRDPT

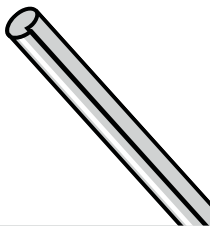

	PACK		WEIGHT		PG	EZ	BL
	PCS	LBS	KG				
BTRCC6X12	100	2.6	1.2	-	-	801 001	-
CA	50	2.2	1.0	-	-	801 051	942 881
ECLI	10	0.04	0.02	557 190	-	-	942 797
EZ BN 1/4	50	2.0	0.9	-	-	941 084	-
EZ BN 5/16	50	1.3	0.6	-	-	942 778	-
EZ CN 1/4	100	3.0	1.4	-	-	941 094	-
EZ CN 3/8	100	4.0	1.8	-	-	941 205	-
EZ CN 1/2	100	5.0	2.3	-	-	942 790	-
EZ FW 1/4	100	0.5	0.2	-	-	941 511	-
EZ FW 3/8	100	0.6	0.3	-	-	941 612	-
EZ FW 1/2	100	0.5	0.2	-	-	942 464	-
EZ HN 1/4	100	0.6	0.3	-	-	941 713	-
EZ HN 3/8	100	0.7	0.3	-	-	941 915	-
EZ HN 1/2	100	2.0	0.9	-	-	941 814	-

	PACK	LENGTH		WEIGHT		PITCH	EZ	PL
		FT	M	LBS	KG			
THRDPT	10	6.0	0.15	0.16	0.07	-	-	942 947
THRD 1/4*	1	6.0	1.8	0.7	0.3	20	942 351	-
THRD 3/8*	1	6.0	1.8	1.8	0.8	16	942 353	-
THRD 1/2*	1	6.0	1.8	3.1	1.4	12	942 465	-

- Contact manufacturer for availability.

*Thread Pitch: 1/4" - 20; 3/8" - 16; 1/2" - 13



INSTALLATION GUIDELINES



View
Installation Video



CUTTING STRAIGHT SECTIONS

Trough tray can be cut to length with a reciprocating saw fitted with a fine metal cutting blade. Mark three sides of the tray using a square and make allowances to keep mounting hole slots in position for splicing to other straight sections or fittings. Use a flat file to remove all rough edges. Cover sections can be modified in the same way.



CUTTING STRAIGHT SECTIONS FOR ELEVATION CHANGES

Cut only the sides of the tray for changes in cable pathway elevations. Make a 90 degree cut in both sides of the tray for a downward bend. For an upward bend, make a double cut to form a notch. The notch should be sized to fit the tray angle needed. Then, using a straight edge, form the tray to the proper angles.



SPLICING STRAIGHT SECTIONS AND FITTINGS

To splice straight sections of trough tray use the FTEF. The FTEF has attachment hardware included and should be used when splicing straight sections or fittings.



SPLICING TEES, REDUCTIONS AND LEVEL CHANGES

The FTUS is a versatile splice that can be used to construct tees, reductions and elevation changes, thus reducing the need for formed fittings. Use with EZ BN 1/4 bolt/nut or BTRCC6x12.

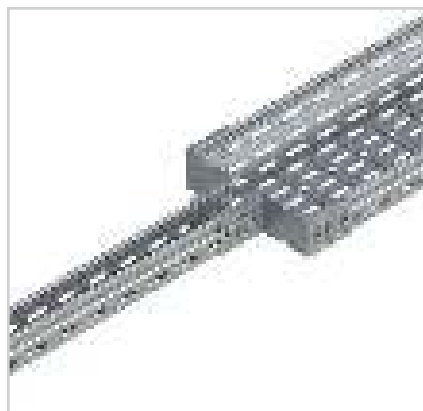
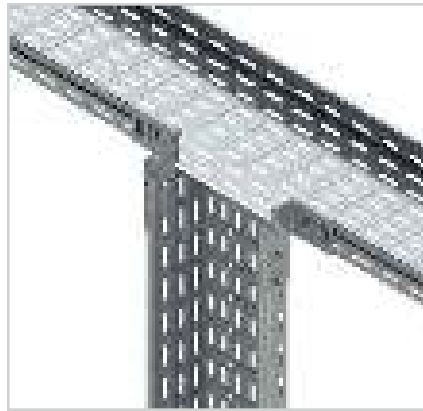

ATTACHING TO WALL OR FLOOR SUPPORTS

Securing ventilated tray to supports is easy. For attachment to the FAS U or CS series support, use the FTFCL. It simply snaps in place. For securing solid tray use the FTHDCL Tray Hold Down Clip. Both allow a cover to be used.



TRAPEZE SUPPORTS

For trapeze mounting, three options are available: The FTCH and FTCHC Center Hangers both require only a single threaded rod. The FTAS Trapeze Hanging Clip requires two 3/8" threaded rods, but allows cables to be side loaded. Folding tabs secure tray to supports. Covers can be used with FTCHC but not FTCH or FTAS.



COVER ATTACHMENT OPTIONS

Complete the security of your cables with covers. These cover sections can be cut to fit with a reciprocating saw and simply snap on. For additional security, use the FTCFCL Cover Fastening Clip. This clip can be used in conjunction with splicing hardware to keep covers secure.



DESCRIPTION >	STRAIGHT SOLID SECTION				STRAIGHT VENTILATED SECTION				FITTINGS							
ITEM >	FT				VT				FTFB90				FTFB45			

TRAY HEIGHT (H) = 2.0 in / 50mm

TRAY WIDTH (W)	IN	2.0	3.9	7.9	11.8	2.0	3.9	7.9	11.8	2.0	3.9	7.9	11.8	2.0	3.9	7.9	11.8
	MM	50	100	200	300	50	100	200	300	50	100	200	300	50	100	200	300
RADIUS (R)	IN	-	-	-	-	-	-	-	-	0.8	3.9	3.9	3.9	0.8	3.9	3.9	3.9
	MM	-	-	-	-	-	-	-	-	20	100	100	100	20	100	100	100
LENGTH 1 (L1)	IN	-	-	-	-	-	-	-	-	-	9.1	13.0	16.9	4.7	7.6	10.4	13.1
	MM	-	-	-	-	-	-	-	-	-	230	330	430	120	194	264	334
LENGTH 2 (L2)	IN	-	-	-	-	-	-	-	-	3.9	9.1	13.0	16.9	3.4	5.9	9.9	9.9
	MM	-	-	-	-	-	-	-	-	100	230	330	430	85	151	251	251
TANGENT (C)	IN	-	-	-	-	-	-	-	-	1.2	1.2	1.2	1.2	1.2	1.2	1.2	1.2
	MM	-	-	-	-	-	-	-	-	30	30	30	30	30	30	30	30
WEIGHT	LBS	4.9	6.9	11.7	19.6	4.9	6.9	11.7	19.6	0.6	1.6	3.7	6.5	0.4	0.6	1.1	1.8
	KG	2.43	3.14	5.30	8.90	2.43	3.14	5.30	8.90	0.26	0.74	1.67	2.94	0.19	0.29	0.51	0.81

TRAY HEIGHT (H) = 3.9 in / 100mm

TRAY WIDTH (W)	IN	3.9	7.8	11.8	19.7	23.6	3.9	7.8	11.8	19.7	23.6	3.9	7.8	11.8	19.7	23.6
	MM	100	200	300	500	600	100	200	300	500	600	100	200	300	500	600
RADIUS (R)	IN	-	-	-	-	-	-	-	-	-	-	3.9	3.9	3.9	5.9	5.9
	MM	-	-	-	-	-	-	-	-	-	-	100	100	100	150	150
LENGTH 1 (L1)	IN	-	-	-	-	-	-	-	-	-	-	9.1	13.0	16.9	27.6	31.5
	MM	-	-	-	-	-	-	-	-	-	-	230	330	430	700	800
LENGTH 2 (L2)	IN	-	-	-	-	-	-	-	-	-	-	9.1	13.0	16.9	27.6	31.5
	MM	-	-	-	-	-	-	-	-	-	-	230	330	430	700	800
TANGENT (C)	IN	-	-	-	-	-	-	-	-	-	-	1.2	1.2	1.2	2.0	2.0
	MM	-	-	-	-	-	-	-	-	-	-	30	30	30	50	50
WEIGHT	LBS	11.7	19.7	29.8	43.1	45.1	11.7	19.7	29.8	43.1	45.1	2.1	4.5	7.3	17.9	22.5
	KG	5.31	8.94	13.52	19.55	20.46	5.31	8.94	13.52	19.55	20.46	0.97	2.03	3.29	8.14	10.20

UNIVERSAL ADJUSTABLE SPLICE
FTUS

See pages C.10, C.28

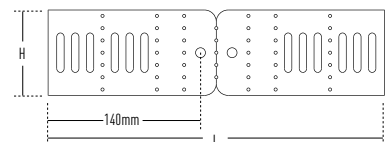

FITTINGS

FTVI90

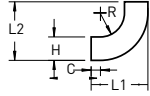

FTV090

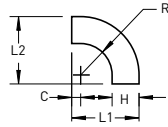

FTT

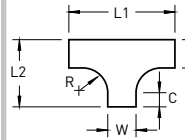

FTB

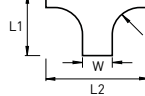

FTX

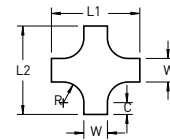

FTVT

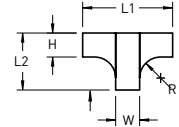



TRAY HEIGHT (H) = 2.0 in / 50mm

FTVI90				FTV090				FTT				FTB				FTX				FTVT			
2.0	3.9	7.9	11.8	2.0	3.9	7.9	11.8	2.0	3.9	7.9	11.8	2.0	3.9	7.9	11.8	2.0	3.9	7.9	11.8	2.0	3.9	7.9	11.8
50	100	200	300	50	100	200	300	50	100	200	300	50	100	200	300	50	100	200	300	50	100	200	300
0.8	3.9	3.9	3.9	0.8	5.0	5.0	5.0	0.8	3.9	3.9	3.9	0.8	3.9	3.9	3.9	0.8	3.9	3.9	3.9	-	3.9	3.9	3.9
20	100	100	100	20	127	127	127	20	100	100	100	20	100	100	100	20	100	100	100	-	100	100	100
3.9	7.1	7.1	7.1	3.9	8.3	8.3	8.3	5.9	14.2	18.1	22.0	3.8	7.1	7.1	7.1	5.9	14.2	18.1	22.0	5.9	14.2	18.1	22.0
100	180	180	180	100	210	210	210	150	360	460	560	96	180	180	180	150	360	460	560	150	360	460	560
3.9	7.1	7.1	7.1	3.9	8.3	8.3	8.3	3.9	9.1	13.0	16.9	5.9	14.1	18.0	22.0	5.9	14.2	18.1	22.0	3.9	8.3	9.4	11.8
100	180	180	180	100	210	210	210	100	230	330	430	150	358	458	558	150	360	460	560	100	210	240	300
1.2	1.2	1.2	1.2	1.2	1.2	1.2	1.2	1.2	1.2	1.2	1.2	-	-	-	-	1.2	1.2	1.2	1.2	-	-	-	-
30	30	30	30	30	30	30	30	30	30	30	30	-	-	-	-	30	30	30	30	-	-	-	-
0.5	1.1	1.6	2.1	0.4	1.1	1.6	2.0	0.6	1.7	3.0	4.7	0.7	1.6	2.2	2.8	0.7	2.4	4.1	6.2	0.7	2.9	5.3	8.7
0.21	0.49	0.72	0.95	0.17	0.51	0.71	0.91	0.26	0.79	1.37	2.11	0.30	0.74	0.99	1.25	0.31	1.09	1.86	2.81	0.31	1.30	2.42	3.95

TRAY HEIGHT (H) = 3.9 in / 100mm

FTVI90				FTV090				FTT				FTB				FTX				FTVT				
3.9	7.8	11.8	19.7	23.6	3.9	7.8	11.8	19.7	23.6	3.9	7.8	11.8	19.7	23.6	3.9	7.8	11.8	19.7	23.6	3.9	7.8	11.8	19.7	-
100	200	300	500	600	100	200	300	500	600	100	200	300	500	600	100	200	300	500	600	100	200	300	500	-
5.9	5.9	5.9	5.9	5.9	5.9	5.9	5.9	5.9	5.9	3.9	3.9	3.9	5.9	5.9	3.9	3.9	3.9	5.9	5.9	3.9	3.9	3.9	3.9	-
150	150	150	150	150	150	150	150	150	150	100	100	100	150	150	100	100	100	150	150	100	100	100	100	-
11.8	11.8	11.8	11.8	11.8	11.9	11.9	11.9	11.9	11.9	14.2	18.1	22.0	35.4	39.4	7.1	7.1	7.1	9.8	9.8	14.2	18.1	22.0	35.4	39.4
300	300	300	300	300	301	301	301	301	301	360	460	560	900	1000	180	180	180	250	250	360	460	560	900	1000
11.8	11.8	11.8	11.8	11.8	11.9	11.9	11.9	11.9	11.9	9.1	13.0	16.9	27.6	31.5	14.1	18.0	22.8	35.4	39.3	14.2	18.1	22.0	35.4	39.4
300	300	300	300	300	301	301	301	301	301	230	330	430	700	800	358	458	558	898	998	360	460	560	900	1000
2.0	2.0	2.0	2.0	2.0	2.0	2.0	2.0	2.0	2.0	1.2	1.2	1.2	2.0	2.0	-	-	-	-	-	1.2	1.2	1.2	2.0	2.0
50	50	50	50	50	50	50	50	50	50	30	30	30	50	50	-	-	-	-	-	30	30	30	50	50
3.2	4.5	5.8	8.4	9.5	3.3	4.5	5.8	8.4	10.1	3.7	6.2	9.8	20.8	26.0	2.2	2.6	3.3	6.2	7.1	4.5	7.6	11.4	23.8	30.2
1.47	2.06	2.62	3.83	4.30	1.50	2.06	2.64	3.80	4.60	1.69	2.83	4.43	9.44	11.80	1.00	1.20	1.50	2.80	3.20	2.04	3.44	5.19	10.81	13.70

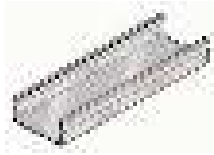
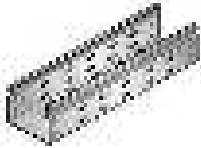

DESCRIPTION >	STRAIGHT SECTION	STRAIGHT VENTILATED SECTION	FITTINGS	
ITEM >	FT	VT	FTFB90	FTFB45
				
TRAY DIMENSIONS (HxW)	C.8	C.8	C.12	C.12
2" x 2" 50 x 50 mm	FT 50/50	VT 50/50	FTFB90 50/50	FTFB45 50/50
2" x 4" 50 x 100 mm	FT 50/100	VT 50/100	FTFB90 50/100	FTFB45 50/100
2" x 8" 50 x 200 mm	FT 50/200	VT 50/200	FTFB90 50/200	FTFB45 50/200
2" x 12" 50 x 300 mm	FT 50/300	VT 50/300	FTFB90 50/300	FTFB45 50/300
4" x 4" 100 x 100 mm	FT 100/100	VT 100/100	FTFB90 100/100	FTFB45 100/100
4" x 8" 100 x 200 mm	FT 100/200	VT 100/200	FTFB90 100/200	FTFB45 100/200
4" x 12" 100 x 300 mm	FT 100/300	VT 100/300	FTFB90 100/300	FTFB45 100/300
4" x 20" 100 x 500 mm	FT 100/500	VT 100/500	FTFB90 100/500	FTFB45 100/500
4" x 24" 100 x 600 mm	FT 100/600	VT 100/600	FTFB90 100/600	FTFB45 100/600
CORRESPONDING COVER	FTC	FTC	FTCFB90	FTCFB45

FITTINGS						
FTVI90	FTVO90	FTT	FTB	FTX	FTVT	
						
C.13	C.13	C.14	C.14	C.15	C.15	
FTVI90 50/50	FTVO90 50/50	FTT 50/50	FTB 50/50	FTX 50/50	FTVT 50/50	
FTVI90 50/100	FTVO90 50/100	FTT 50/100	FTB 50/100	FTX 50/100	FTVT 50/100	
FTVI90 50/200	FTVO90 50/200	FTT 50/200	FTB 50/200	FTX 50/200	FTVT 50/200	
FTVI90 50/300	FTVO90 50/300	FTT 50/300	FTB 50/300	FTX 50/300	FTVT 50/300	
FTVI90 100/100	FTVO90 100/100	FTT 100/100	FTB 100/100	FTX 100/100	FTVT 100/100	
FTVI90 100/200	FTVO90 100/200	FTT 100/200	FTB 100/200	FTX 100/200	FTVT 100/200	
FTVI90 100/300	FTVO90 100/300	FTT 100/300	FTB 100/300	FTX 100/300	FTVT 100/300	
FTVI90 100/500	FTVO90 100/500	FTT 100/500	FTB 100/500	FTX 100/500	FTVT 100/500	
FTVI90 100/600	FTVO90 100/600	FTT 100/600	FTB 100/600	FTX 100/600	—	
FTCVI90	FTCV090	FTTC	FTBC	FTXC	INCLUDED	



FASTENERS

TABLE OF CONTENTS

INTRODUCTION

PAGES D.1

J-HOOKS

PAGES D.2-D.8

OTHER FASTENERS

PAGES D.9-D.11

FAS POWER

PAGES D.12-D.23

CABLOPORT

PAGES D.24-D.31

SEISMIC BRACING

PAGES D.32-D.38



LEGRAND FASTENERS



Fasteners and prefab components for everyday applications.

Our electrical fasteners and components are designed to get you on and off of the job-site in record time. Hammer-on J-Hooks, FAS Power pre-fab components and CabloPort rooftop supports are just a few examples of products that reduce labor, increasing your bottom line.

Cablofil fasteners and components are perfect for branch wiring in these project types:

- **Hotels**
- **Office Complexes**
- **Condominiums**
- **Hospitals**
- **Government Buildings**



Also included in this catalog is a full line of seismic brace systems and attachment hardware. Each product is designed with quality materials for optimum performance in any installation.



LEGRAND J-HOOKS

Cable management that's
fast and **secure**

Cablofil J-Hooks provides an easy-to-install, non-continuous cable support for all types of telecommunication, data and power cabling. They also are perfect for low voltage building management and fire protection cabling.

Our CJ Series is engineered to provide stress-free cable support for multiple cables and features a structural design for optimal strength and tapered edges to reduce cable sheath damage. Multiple pre-drilled holes reduce on-site modification at installation. Cablofil J-Hooks can be attached to a variety of structures and are available with multiple attachment options that allow quick and easy cable installation virtually anywhere.



J-HOOKS FEATURES:

- From 3/4" to 4" sizes available with multiple attachment options
- Ready to use out of the box, reducing installation time and labor costs
- Requires no special attachment hardware or tools for assembly
- Provides superior fill capacity and load rating
- Tree configurations provide multiple J-Hooks with one structural attachment
- Meets ISO®/IEC 14763-2, TIA 568-C and TIA 569-C
- Complies with EN 50174-2
- Available in Red or Blue (other colors are also available)
- Marking mylar tabs available for post installation needs. (Contact manufacturer for availability)
- cULus® Listed

CJ12 D.4
3/4" J-HOOK

CJ21 D.4
1-5/16" J-HOOK

CJ32 D.4
2" J-HOOK

CJ64 D.4
4" J-HOOK

CJHP16 D.6
1" J-HOOK

CJHP32 D.6
2" J-HOOK

CJHP48 D.6
3" J-HOOK

CJ4T125 D.7
1-1/4" BRIDLE RING

CJ4T2 D.7
2" BRIDLE RING

CJ TREE D.8
J-HOOK TREE

CJHP TREE D.8
PLASTIC COATED
J-HOOK TREE



CJ12
3/4" J-HOOK

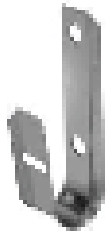

	WEIGHT		EZ
	PCS	LBS	
CJ12	50	2.5	F000001
CJ12W	50	3.5	F000002
CJ12AC	50	4	F000003
CJ12HOK24	50	5	F000004
CJ12HOK58	50	5	F000005
CJ12PBC	50	8.5	F000006
CJ12ACPBC	50	10	F000007
CJ12SSBC	50	5.5	F000008
CJ12ACSSB	50	7	F000009
CJ12ACHOK24	50	6.5	F000010

CJ21
1 5/16" J-HOOK



	WEIGHT		EZ
	PCS	LBS	
CJ21	50	6.5	F000011
CJ21W	50	7.5	F000012
CJ21AC	50	8.5	F000013
CJ21HOK24	50	9	F000014
CJ21HOK58	50	9	F000015
CJ21PBC	50	12.5	F000016
CJ21ACPBC	50	14	F000017
CJ21SSBC	50	9.5	F000018
CJ21ACSSB	50	11.5	F000019
CJ21ACHOK24	50	11.5	F000020

CJ32
2" J-HOOK

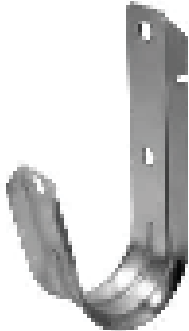

	WEIGHT		EZ
	PCS	LBS	
CJ32	50	7.5	F000021
CJ32W	50	8.5	F000022
CJ32AC	50	9.5	F000023
CJ32HOK24	50	10	F000024
CJ32HOK58	50	13.5	F000025
CJ32PBC	50	15	F000026
CJ32ACPBC	50	10	F000027
CJ32SSBC	50	10.5	F000028
CJ32ACSSB	50	12.5	F000029
CJ32ACHOK24	50	12.5	F000030

CJ64
4" J-HOOK



	WEIGHT		EZ
	PCS	LBS	
CJ64	25	7.5	F000031
CJ64W	25	8.5	F000032
CJ64AC	25	12.5	F000039
CJ64HOK24	25	9.5	F000033
CJ64HOK58	25	10	F000034
CJ64PBC	25	13.5	F000035
CJ64ACPBC	25	15	F000036
CJ64SSBC	25	10.5	F000037
CJ64ACSSB	25	12.5	F000038
CJ64AC6	25	12.5	F000040
CJ64ACHOK24	25	12.5	F000041

PART NUMBERING EXAMPLE

CJ12 HOK24







J-HOOK
Choose between
CJ12, CJ21, CJ32 & CJ64

ATTACHMENT
See options on D.5

LOAD CAPACITY TABLE

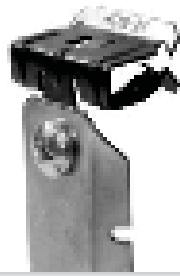
	HOOK SIZE		LOAD CAPACITY	CABLE CAPACITY		
	IN	LBS		4-PAIR UTP CAT 5E	CAT 6	2 STRAND FIBER OPTIC
	CJ12	¾	17	16	10	16
CJ21	1⅝	17	50	32	50	
CJ32	2	17	80	50	80	
CJ64	4	50	300	220	300	

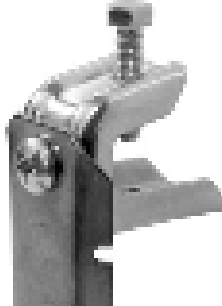
ATTACHMENT OPTIONS

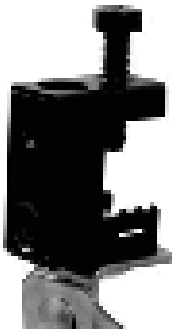
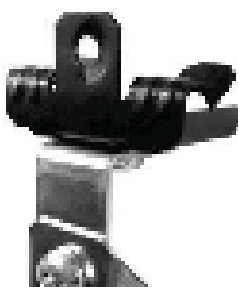
<p>W</p>  <p>Bat wing 12 gage – ¼" ATR</p>	<p>AC</p>  <p>90° angled clip – ¼" hole</p>	<p>AC6</p>  <p>90° angled clip – ⅜" hole</p>	<p>HOK24</p>  <p>Knock-on steel beam clamp – ⅛" to ¼"</p>
<p>HOK58</p>  <p>Knock-on steel beam clamp – ⅝" to ½"</p>	<p>PBC</p>  <p>Pressed beam clamp – up to ½"</p>	<p>CPBC</p>  <p>Angled clip and pressed beam clamp – up to ½"</p>	<p>SSBC</p>  <p>Assembled to SSBC – ⅛" to ½"</p>
<p>ACSSB</p>  <p>Angled clip and SSBC – swivels 360°</p>	<p>ACHOK24</p>  <p>Knock-on clamp and angled clip – swivels 360°</p>		



The 'Cable Cage' J-Hook features a built in latch that allows you to lock the bendable flap into place – up to 50 times with no signs of metal fatigue. CJP J-Hooks combine the best features of both metal and plastic, providing strength and a slick, no-bur surface for easy cable pulling. They will support all types of data communication and low-voltage cabling and are available with a number of ready-made accessories for attachment to a wide variety of structures and surfaces. All CJP Hooks are plenum-safe.

CJ16HP
1" J-HOOK

CJ32HP
2" J-HOOK

CJ48HP
3" J-HOOK

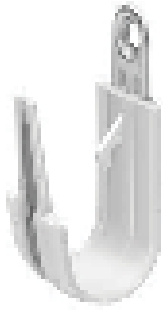

PART NUMBERING EXAMPLE

CJ16HPW

J-HOOK

Choose between
CJ16HP, CJ32HP & CH48HP

ATTACHMENT

See options below

CJHP ATTACHMENT OPTIONS

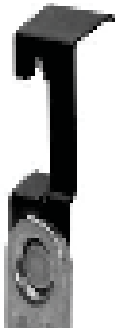
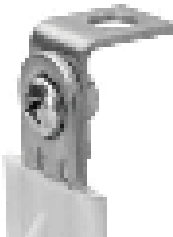
<p>W</p>  <p style="text-align: center;">Bat wing</p>	<p>AC</p>  <p style="text-align: center;">90° angled clip</p>

	WEIGHT		EZ
	PCS	LBS	
CJ16HP	50	2.5	F000051
CJ16HPW	50	4	F000059
CJ16HPAC	50	5	F000060
CJ32HP	50	5	F000052
CJ32HPW	50	6.5	F000061
CJ32HPAC	50	6.5	F000062
CJ48HP	25	15.5	F000053
CJ48HPW	25	18	F000063
CJ48HPAC	25	17.5	F000064

CJHP LOAD CAPACITY TABLE

	HOOK SIZE	LOAD CAPACITY	CABLE CAPACITY		
	IN	LBS	4-PAIR UTP CAT 5E	CAT 6	2 STRAND FIBER OPTIC
CJ16HP	1	17	20	15	20
CJ32HP	2	17	90	60	90
CJ48HP	3	50	200	150	200

J-HOOKS

D.6

ATTACHMENTS

Use these attachment options to create your own custom J-Hook combinations. **Sold in quantities of 100.**

CJ ATTACHMENT MOUNTING HARDWARE			
<p>CJ24</p>  <p>Knock-on steel beam clamp – 1/8" to 1/4"</p>	<p>CJ58</p>  <p>Knock-on steel beam clamp – 5/16" to 1/2"</p>	<p>CJFMP</p>  <p>Knock-on spring steel beam clamp – 1/8" to 1/2"</p>	<p>CJBC</p>  <p>Pressed beam clamp – up to 1/2"</p>
<p>CJSSBC</p>  <p>Spring steel beam clamp 1/8" – 1/2"</p>	<p>CJZ14</p>  <p>1/8" – 1/4" Z Purlin</p>	<p>CJC14</p>  <p>1/8" – 1/4" C Purlin</p>	<p>CJBW</p>  <p>Bat wing 12 gage – 1/4" ATR</p>

BRIDLE RINGS

Bridle rings are a simple option for smaller bundles of communication or data cabling.



J-HOOK BRIDLE RING OPTIONS

	RING DIA.		DESCRIPTION	WEIGHT	EZ
	PCS	IN		LBS	
CJ4T125	100	1 1/4	Bridle Ring 1/4 x 20 threads	6	F000042
CJ4T2	100	2	Bridle Ring 1/4 x 20 threads	9	F000043



J-HOOK TREES

J-Hook Trees are the ideal solution for segregating up to five runs of cable following the same cable pathway. They are ready to use with no assembly required in multiple sizes and attachment methods.

These items are not stocked in our inventory. Please contact the manufacturer for shipping information, pricing and other configurations.



CJ64-SB-2

CJ TREES

	WEIGHT	
	HOOK COUNT	LBS
1 5/16" VERTICAL TREE SUPPORTS		
CJ21-SB-2	2	1.4
CJ21-SB-3	3	2.4
CJ21-SB-4	4	3.4
CJ21-SB-5	5	3.9
w/ ANGLE CLIP		
CJ21-AC-SB-2	2	1.4
CJ21-AC-SB-3	3	2.4
CJ21-AC-SB-4	4	3.4
CJ21-AC-SB-5	5	3.9
w/ BEAM CLAMP		
CJ21-PBC-SB-2	2	1.9
CJ21-PBC-SB-3	3	2.4
CJ21-PBC-SB-4	4	3.4
CJ21-PBC-SB-5	5	4.4

	WEIGHT	
	HOOK COUNT	LBS
2" VERTICAL TREE SUPPORTS		
CJ32-SB-2	2	1.6
CJ32-SB-3	3	2.6
CJ32-SB-4	4	3.6
CJ32-SB-5	5	4.1
w/ ANGLE CLIP		
CJ32-AC-SB-2	2	1.6
CJ32-AC-SB-3	3	2.6
CJ32-AC-SB-4	4	3.6
CJ32-AC-SB-5	5	4.1
w/ BEAM CLAMP		
CJ32-PBC-SB-2	2	2.1
CJ32-PBC-SB-3	3	2.6
CJ32-PBC-SB-4	4	3.6
CJ32-PBC-SB-5	5	4.6

	WEIGHT	
	HOOK COUNT	LBS
4" VERTICAL TREE SUPPORTS		
CJ64-SB-2	2	1.5
CJ64-SB-3	3	2.2
CJ64-SB-4	4	-
CJ64-SB-5	5	3.6
w/ ANGLE CLIP		
CJ64-AC-SB-2	2	2
CJ64-AC-SB-3	3	3
CJ64-AC-SB-4	4	4
CJ64-AC-SB-5	5	4.5
w/ BEAM CLAMP		
CJ64-PBC-SB-2	2	2.5
CJ64-PBC-SB-3	3	3
CJ64-PBC-SB-4	4	4
CJ64-PBC-SB-5	5	5

CJHP TREES

	WEIGHT	
	HOOK COUNT	LBS
1" VERTICAL TREE SUPPORTS WITH PLASTIC COATED HOOKS		
CJ16HP-SB-2	2	1.4
CJ16HP-SB-3	3	2.4
CJ16HP-SB-4	4	3.4
CJ16HP-SB-5	5	3.9
w/ ANGLE CLIP		
CJ16HP-AC-SB-2	2	1.4
CJ16HP-AC-SB-3	3	2.4
CJ16HP-AC-SB-4	4	3.4
CJ16HP-AC-SB-5	5	3.9
w/ BEAM CLAMP		
CJ16HP-PBC-SB-2	2	1.9
CJ16HP-PBC-SB-3	3	2.4
CJ16HP-PBC-SB-4	4	3.4
CJ16HP-PBC-SB-5	5	4.4

	WEIGHT	
	HOOK COUNT	LBS
2" VERTICAL TREE SUPPORTS WITH PLASTIC COATED HOOKS		
CJ32HP-SB-2	2	1.6
CJ32HP-SB-3	3	2.6
CJ32HP-SB-4	4	3.6
CJ32HP-SB-5	5	4.1
w/ ANGLE CLIP		
CJ32HP-AC-SB-2	2	1.6
CJ32HP-AC-SB-3	3	2.6
CJ32HP-AC-SB-4	4	3.6
CJ32HP-AC-SB-5	5	4.1
w/ BEAM CLAMP		
CJ32HP-PBC-SB-2	2	2.1
CJ32HP-PBC-SB-3	3	2.6
CJ32HP-PBC-SB-4	4	3.6
CJ32HP-PBC-SB-5	5	4.6

	WEIGHT	
	HOOK COUNT	LBS
3" VERTICAL TREE SUPPORTS WITH PLASTIC COATED HOOKS		
CJ48HP-SB-2	2	2
CJ48HP-SB-3	3	2
CJ48HP-SB-4	4	4
CJ48HP-SB-5	5	4
w/ ANGLE CLIP		
CJ48HP-AC-SB-2	2	2
CJ48HP-AC-SB-3	3	3
CJ48HP-AC-SB-4	4	4
CJ48HP-AC-SB-5	5	4
w/ BEAM CLAMP		
CJ48HP-PBC-SB-2	2	2
CJ48HP-PBC-SB-3	3	3
CJ48HP-PBC-SB-4	4	4
CJ48HP-PBC-SB-5	5	4



ROD COUPLING NUT FLAT, ROUND WASHER HEX NUT SLIP-ON LOCK NUT THREADED ROD THREADED ROD PROTECTOR

DESCRIPTION	PRODUCT NUM.	QTY.	DIA.	LENGTH	PITCH	EZ	GC	304L	316L	BL	PE	PL	ZN
ROD COUPLING NUT	EZ CN 1/4	100	1/4	—	20	941 094	—	—	941 060	—	—	—	—
	EZ CN 3/8	100	3/8	—	16	941 205	—	—	941 061	—	—	—	—
	EZ CN 1/2	100	1/2	—	13	942 790	942 791	—	942 792	942 793	942 794	—	—
	DS-0237-06-ZN			5/8	—	—	—	—	—	—	—	—	*
FLAT, ROUND WASHER	EZ FW 1/4	100	1/4	—	20	941 511	942 687	—	941 065	942 309	942 381	—	—
	EZ FW 3/8	100	3/8	—	16	941 612	942 688	—	941 066	942 310	942 382	—	—
	EZ FW 1/2	100	1/2	—	13	942 464	942 784	—	942 785	942 786	942 787	—	—
	DS-8594-01-ZN			5/8	—	—	—	—	—	—	—	—	*
HEX NUT	EZ HN 1/4	100	1/4	—	20	941 713	—	—	941 067	—	—	—	—
	EZ HN 3/8	100	3/8	—	16	941 915	—	—	941 069	—	—	—	—
	EZ HN 1/2	100	1/2	—	13	941 814	—	—	941 068	—	—	—	—
	DS-8594-01-ZN			5/8	—	—	—	—	—	—	—	—	*
SLIP-ON LOCK NUT	SON1/4	2	1/4	—	20	943 351	—	—	—	—	—	—	—
	SON3/8	2	3/8	—	18	943 352	—	943 355	—	—	—	—	—
	SON1/2	2	1/2	—	12	943 353	—	943 356	—	—	—	—	—
	SON5/8	2	5/8	—	11	943 354	—	—	—	—	—	—	—
THREADED ROD	THRD 1/4	1	1/4	6.0	20	942 351	—	—	942 471	—	—	—	—
	THRD 3/8	1	3/8	6.0	16	942 353	—	—	942 472	—	—	—	—
	THRD 1/2	1	1/2	6.0	13	942 465	—	—	942 789	—	—	—	—
	DS-8594-01-ZN	10	5/8	6.0	—	—	—	—	—	—	—	—	*
THREADED ROD PROTECTOR	THRDPT	10		0.5	—	—	—	—	—	—	—	942 947	

– Contact manufacturer for availability.

* In stock. Contact manufacturer.

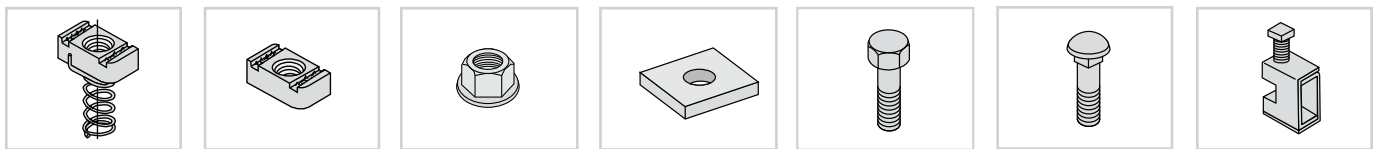

CHANNEL NUT w/ SPRING CHANNEL NUT w/o SPRING FLANGED HEX NUT SQUARE CHANNEL WASHER HEX HEAD BOLT CARRIAGE BOLT BEAM CLAMP

DESCRIPTION	SIZE	ZN	DESCRIPTION	SIZE	ZN	
CHANNEL NUT w/ SPRING	3/8"-16	DS-0102-05-ZN	HEX HEAD BOLT	1/4"-20 x 3/4"	DS-8502-01-ZN	
	1/2"-13	DS-0102-07-ZN		1/4"-20 x 1"	DS-8502-06-ZN	
	5/8"-11	DS-0102-08-ZN		1/4"-20 x 1 1/4"	DS-8502-08-ZN	
CHANNEL NUT w/o SPRING	3/8"-16	DS-0103-05-ZN		1/4"-20 x 1 1/2"	DS-8502-10-ZN	
	1/2"-13	DS-0103-07-ZN		3/8"-16 x 1 1/2"	DS-8520-05-ZN	
	5/8"-11	DS-0103-08-ZN		1/2"-13 x 1 1/2"	DS-8515-15-ZN	
FLANGED HEX NUT	1/4"-20	DS-8845-01-ZN		CARRIAGE BOLT	3/8"-16 x 1 1/2"	DS-8510-04-ZN
	3/8"-16	DS-8524-01-ZN			3/8"-16 x 2 1/2"	DS-8510-08-ZN
	1/2"-13	DS-8644-01-ZN			3/8"-16 x 3"	DS-8510-10-ZN
	5/8"-11	DS-8938-01-ZN			3/8"-16 x 3 1/2"	DS-8510-11-ZN
SQUARE CHANNEL WASHER	1 1/2" w/ 3/8" HOLE	DS-0113-02-ZN	3/8"-16 x 4"		DS-8510-12-ZN	
	1 1/2" w/ 1/2" HOLE	DS-0113-03-ZN	BEAM CLAMP		FOR 1/4" ROD	DS-0221-01-ZN*
	1 1/2" w/ 5/8" HOLE	DS-0113-04-ZN			FOR 3/8" ROD	DS-0221-04-ZN†
		FOR 1/2" ROD		DS-0221-06-ZN†		

Safe Load: *750 lbs.; †1100 lbs.; †1600 lbs.

OTHER FASTENERS



FASCLM KIT
BEAM CLAMP

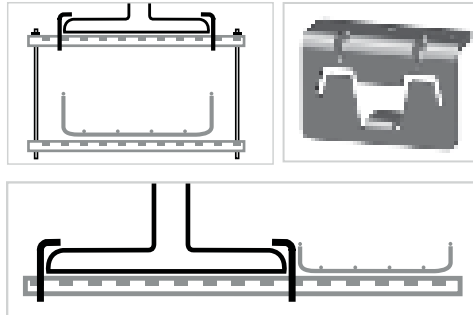
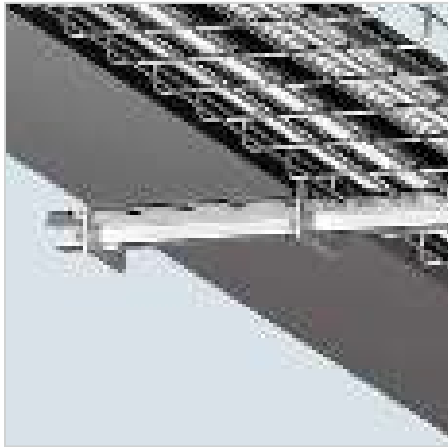

- FAS Clamps attach FAS Profile to I-beams to speed installation time.
- 2 FAS Clamps are included in kit.
- VHM 8 x 20 set screws included.
- No threaded rod required.
- Saves ceiling space.

	PKG. QTY.	WEIGHT		PG
		LBS	KG	
FASCLM KIT	2	0.2	0.15	942 930

ETC
TRAY BEAM SUPPORT

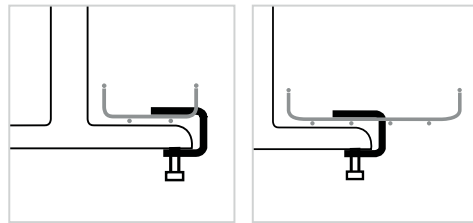
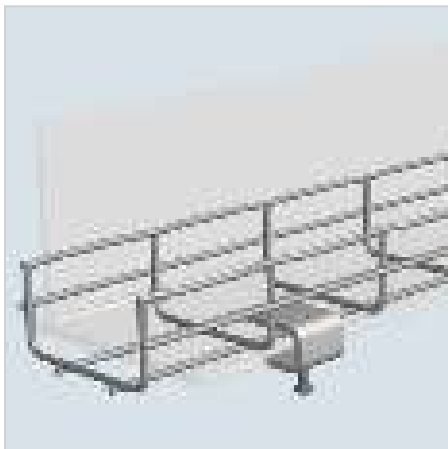

- Clamps tray directly to I-beam.
- No additional attachment hardware needed.
- Set screw included.

	HEIGHT		WEIGHT		GC
	INCHES	MM	LBS	KG	
ETC 20	0.8	20	0.2	0.1	942 819
ETC 30	1.0	30	0.4	0.2	-

- Contact manufacturer for availability.

EZBC
BEAM CLAMP

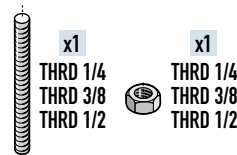
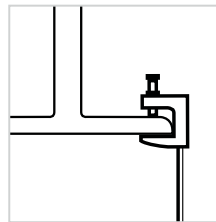

- Attaches threaded rod directly to I-beam.
- Threaded rod and nut are sold separately.
- Set screw and jam nut included.

	WEIGHT		PG	EZ	316L
	LBS	KG			
EZ BC 1/4	0.8	0.36	-	941 063	-
EZ BC 3/8	0.8	0.36	-	941 074	-
EZ BC 1/2	0.8	0.36	-	942 847	-

- Contact manufacturer for availability.



CCLMP CABLE CLAMP

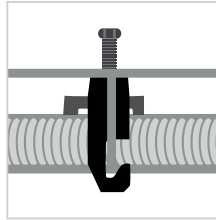
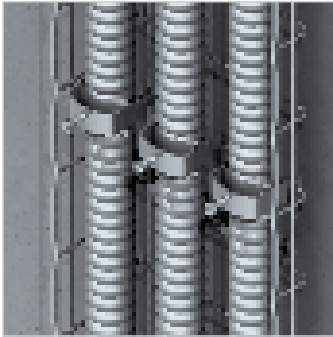

- CCLMP secures MC Cable to tray in vertical installations.
- One-piece design installs quickly using one hand.
- Combo bolt/phillips head requires no special tools to install.

	PKG. QTY.	CABLE SIZE		WEIGHT		EZ
		INCHES	MM	LBS	KG	
CCLMP21	10	0.25-0.84	6-21	0.9	0.41	942 871
CCLMP35	10	0.85-1.35	22-35	1.4	0.64	942 872
CCLMP45	10	1.25-1.75	32-45	2.1	0.95	942 873
CCLMP52	10	1.55-2.05	40-52	3.0	1.36	942 874
CCLMP64	10	2.00-2.50	51-64	3.5	1.59	942 875
CCLMP76	10	2.50-3.00	64-76	3.9	1.77	942 876
CCLMP95	10	3.25-3.75	83-95	4.7	2.45	942 877
CCLMP108	10	3.75-4.25	95-108	5.4	2.45	942 878

CABLO SNAP CABLE BUNDLER

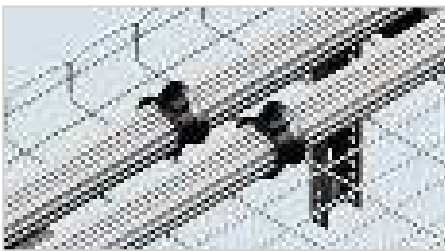

- Protects signal by eliminating over-tightened cable ties
- Add new cables at any time – Cablo Snap is re-useable
- UL Listed, Meets EIA/TIA requirements.
- Plenum Rated

Applying Cablo Snap

1. Position Cablo Snap opening over cable bundle, rotate slightly.
2. Snap Close - squeeze to lock teeth to desired pressure.

Removing Cable Snap

1. Squeeze Cablo Snap to unlock teeth.
2. Rotate Cablo Snap to remove cables.

	PKG. QTY.	WIDTH		WEIGHT		PL*
		INCHES	MM	LBS	KG	
CABLO SNAP 12	25	0.5	12	0.1	0.1	942 952
CABLO SNAP 25	25	1.0	25	0.2	0.1	942 953
CABLO SNAP 37	25	1.5	37	0.6	0.3	942 954
CABLO SNAP 50	25	2.0	50	1.0	0.5	942 955

*PL= Plastic

FS 41 FASTRUT CONNECTOR

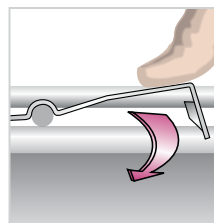
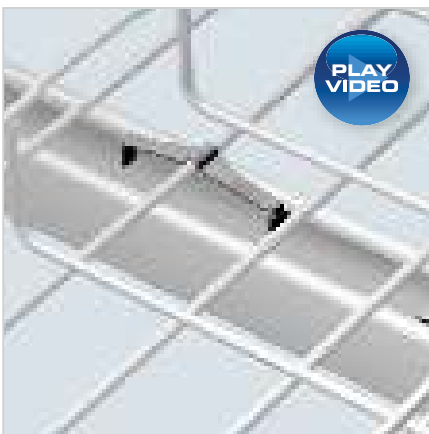

- FASTRUT attaches tray to strut without bolts and nuts or tools.
- Reduces installation time.
- Install FASTRUT on outer wires of tray, and both sides of the strut.
- 2 required for tray 12" or smaller.
- 3 required for tray 18" or larger.

	PKG. QTY.	WEIGHT		DC	316L	BL	PE
		LBS	KG				
FS 41	25	3.3	1.5	599 007	599 004	942 823	942 824



FAS POWER[®]

- D.14 F SERIES**
FLOOR BRACKETS
- D.16 CW SERIES**
SLIDER WALL BRACKETS
- D.17 W SERIES**
WALL BRACKETS
- D.18 FB816**
WALL BRACKET FOR
CONCRETE BLOCKS
- D.21 DCP SERIES**
PLASTIC DEVICE COVERS
- D.21 APR SERIES**
ADJUSTABLE PLASTER RINGS
- D.22 AR SERIES**
SUPPORT ARMS
- D.22 T SERIES**
WALL BRACES

Prefab components that make a difference.

FAS Power components are available for wall and floor assemblies and for concrete block walls. All our components are designed to fit together easily to install quickly. And with FAS Power, the number of components you need to stock is limited as many parts are adjustable to fit multiple wall thicknesses and depths keeping inventoried parts low. FAS Power is the perfect choice for projects with tight schedules.

PREFAB COMPONENT FEATURES:

- Wire manager installs easily and fits most MC wire sizes
- Support Arms adjust to any wall thickness
- Predrilled mounting holes at plate
- 4" and 4-11/16" boxes mount independently from Plaster Ring
- Plaster Rings adjust to fit multiple wall thicknesses
- One to four box position brackets are available
- Clear Debris Covers keeps box interior clean during construction



TELESCOPING BOX BRACKET FEATURES:

- Sizes for 12" to 24" stud spacing
- Fits off-width stud spacing without field modification
- Openings for attachment screws
- Fits multiple box depths
- Offsets designed to keep walls smooth



FAS POWER[®] FLOOR BRACKETS

Sizes to fit **any project.**

FAS Power Floor Brackets make it easy to prefabricate electrical assemblies for branch circuit wiring. It features an innovative built-in wire manager – just remove from base, bend and slip it into place. It manages multiple-sized MC cable types so no attachment to the stud needed. The design permits fast installation anywhere between studs and ensures correct device mounting height without measuring. Other design features include predrilled mounting holes in the base and slots to accept far side supports (sold separately).

Construction: 18 gauge pre-galvanized steel. UL Listed.

Prefabrication: The design accepts 4" and 5" plaster rings and 4" and 4-11/16" square boxes mounted horizontally or vertically. A wire manager is built into the design of the base. Just detach, make a few bends with a pliers and slide in place.

Installation: The Floor Bracket is installed by kicking the lower flange under the wall plate. Two holes are provided for attachment screws if needed. Far Side Support Arms attach to the back of the bracket to support the assembly against the wall behind. No attachment hardware is needed.

Support Arms attach to the back of the bracket using the two slots provided.

Keyhole Openings allow 4" or 4-11/16" x 2-1/8" boxes to remain attached

Attachment Holes for 4" rings allow 4-11/16" x 2-1/8" boxes to be mounted independently.

Attachment Holes for 4-11/16" x 2-1/8" boxes allow 4" rings to be mounted independently

Multiple Box Heights are available from 12" to 24"

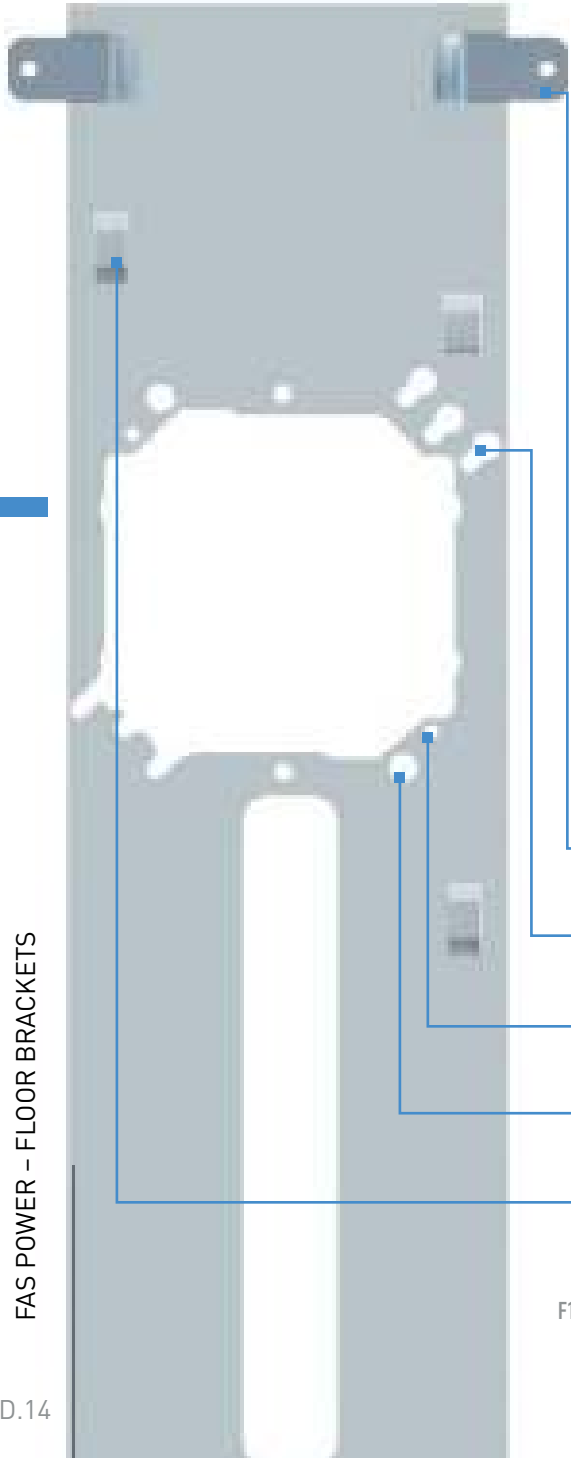

FAS POWER – FLOOR BRACKETS

F112

D.14



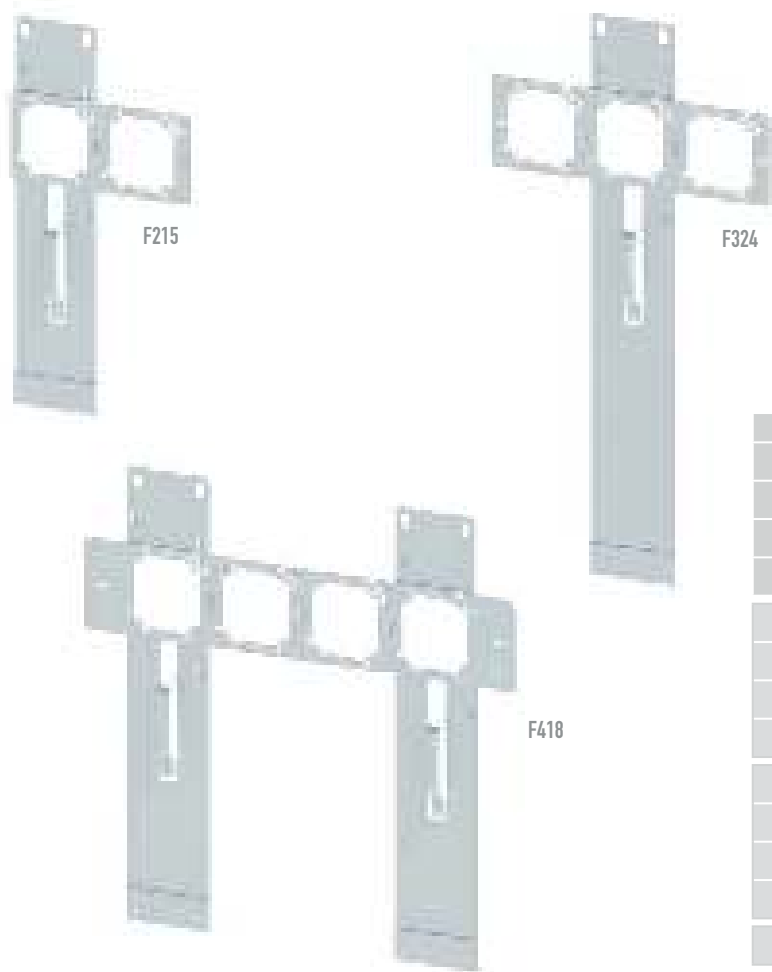

	PKG. QTY.	OPENINGS	CENTER HEIGHT		OVERALL HEIGHT		PG
			IN	MM	IN	MM	
F112	25	1	12	300	5	125	FP981552
F115	25	1	15	380	5	125	FP981553
F118	25	1	18	450	5	125	FP981555
F124	25	1	24	600	5	125	FP981556
F212	25	2	12	300	5	125	FP981557
F215	25	2	15	380	5	125	FP981558
F218	25	2	18	450	5	125	FP981560
F224	25	2	24	600	5	125	FP981561
F312	25	3	12	300	5	125	FP981562
F315	25	3	15	380	5	125	FP981563
F318	25	3	18	450	5	125	FP981565
F324	25	3	24	600	5	125	FP981566
F418	25	4	18	450	5	125	FP981593

WIRE CLAMP INSTRUCTIONS

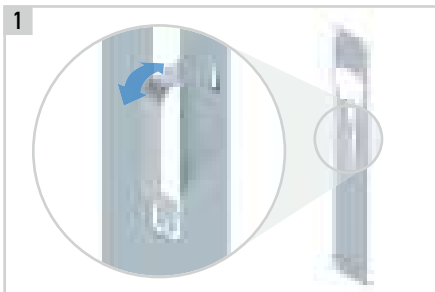

1 Remove clamp from floor bracket by twisting.

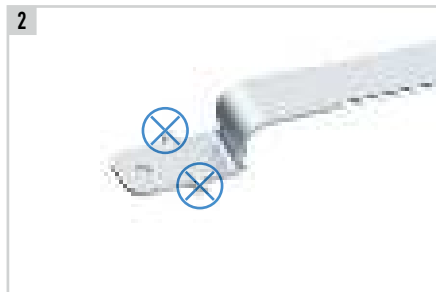

2 Remove attachment tabs – twist off using pliers.



3 Insert formed part of clamp into the back of the bracket into provided slots.



4 Insert straight end of clamp into adjoining clamp slot.



5 Manually bend straight tabs.



FAS POWER[®] WALL BRACKETS

Versatility for any location.

FAS Power Telescoping Brackets make box mounting quick and easy. Design for wall mounting with standard or off-width stud spacing from 11" to 24" without cutting or field fabrication.

TELESCOPING BOX BRACKETS

Available in two sizes, this sturdy bracket can be used for mounting boxes or for cable support. Openings allow for easy box mounting and mounting to the stud. End tabs easily fold to fit multiple box depths. The length is locked into place when the box is mounted using two screws (not supplied). These brackets offer offsets of 1-1/2" and 2-1/8".

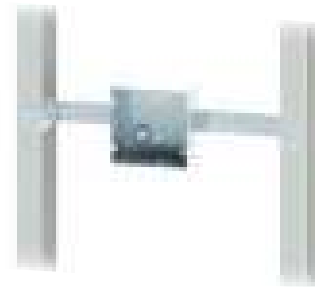
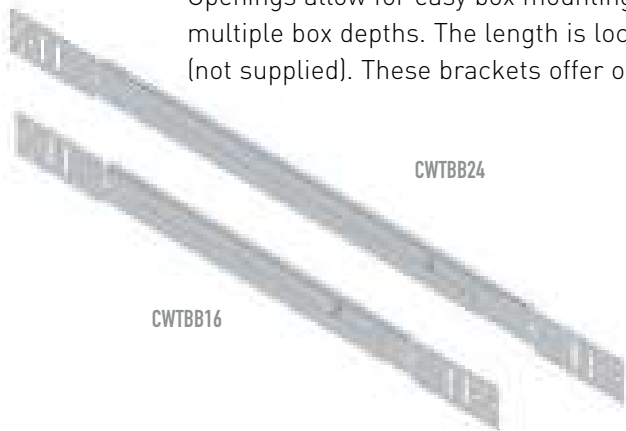

TELESCOPING BOX SUPPORT

For heavier loads or multiple box placements, this support is the answer. Fits 16" to 24" stud placements and anything in between – no cutting or field fabrication is needed. Any 4-11/16" box mounts from the back and is secured when the plaster ring is attached from the front side. Side-to-side adjustment is easy after mounting.

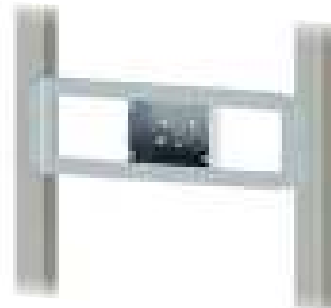
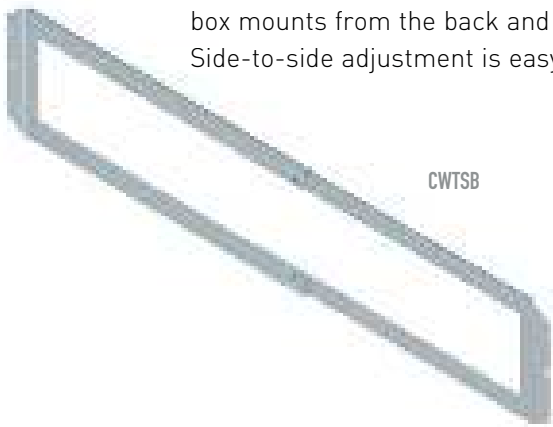

	DESCRIPTION	PKG. QTY.	MIN. LENGTH		MAX. LENGTH		PKG. WEIGHT		PG
			INCHES	MM	INCHES	MM	LBS	KG	
CWTBB16	Telescoping Box Bracket	50	11	270	18	450	25	55	F00065
CWTBB24	Telescoping Box Bracket	50	17	430	26	660	33	73	F00066
CWTSB	Telescoping Support Bracket	25	16	400	27	685	20	44	F00067

FAS Power Wall Brackets make prefabricating switch and outlet assemblies easy. The design includes mounting holes and slots to accept far side supports (sold separately).

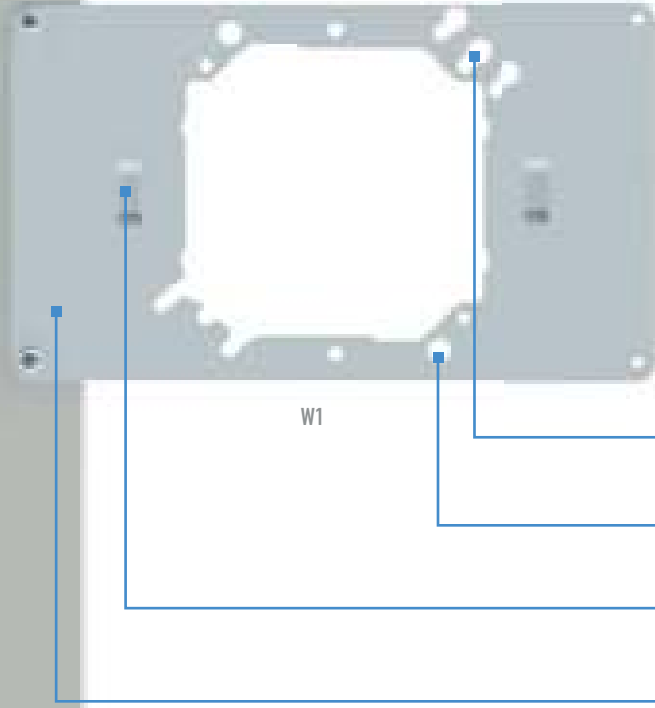

Construction: 18 gage pre-galvanized steel. UL Listed.

Prefabrication: The design accepts 4" and 5" plaster rings and 4", 4-11/16" and 5" square boxes mounted horizontally or vertically.

Installation: Pre-drilled holes are provided for attachment screws to the studs. Far Side Support Arms attach to the back of the bracket to support the assembly against the wall behind. No attachment hardware is needed. (Not required for W16SSL and W24SSL.)

Keyhole Openings allow 4", 4-11/16" and 5" x 2-1/8" boxes to remain attached

Attachment Holes for 4-11/16" x 2-1/8" boxes allow 4" rings to be mounted independently

Support Arms are attached to the back of the bracket using the two slots provided.

Wall Bracket attachment holes



* 16" and 24" slider brackets allow electrical boxes to be adjusted horizontally

	PKG. QTY.	OPENINGS	HEIGHT		WIDTH		PG
			INCHES	MM	INCHES	MM	
W1	50	1	5	125	8.5	215	FP211097
W2	50	2	5	125	11	280	FP211101
W3	25	3	5	125	16.75	425	FP211103
W4	25	4	5	125	26	660	FP211105
W34	25	3	5	125	26	660	FP211104
W16SSL	25	16" Slider	6	150	16.75	425	FP211100
W24SSL	25	24" Slider	6	150	26	660	FP211102



FAS POWER® WALL BRACKETS

Designed for the challenges
of **concrete block walls.**

Box placement can be difficult when building concrete block walls, but the FB816 bracket keeps all wall boxes correctly placed during construction. The FB816 is a special bracket that can be securely mounted into the block cavity keeping the box in place while the mortar dries. Pre-assemble the bracket, box, plaster ring and conduit at rough in, and the assembly will stay perfectly in place.



Construction: 18 gage pre-galvanized steel. ETL Listed. Patented design.

Prefabrication: Designed to hold a 4" x 2-1/8" metallic box.

Installation: Pre-drilled holes are provided for mounting box and plaster ring attachment. After cutting the proper sized opening in the concrete block, position the assembly and tighten mounting screws within the block cavity to keep assembly in place during joint hardening process. All mounting hardware is included.

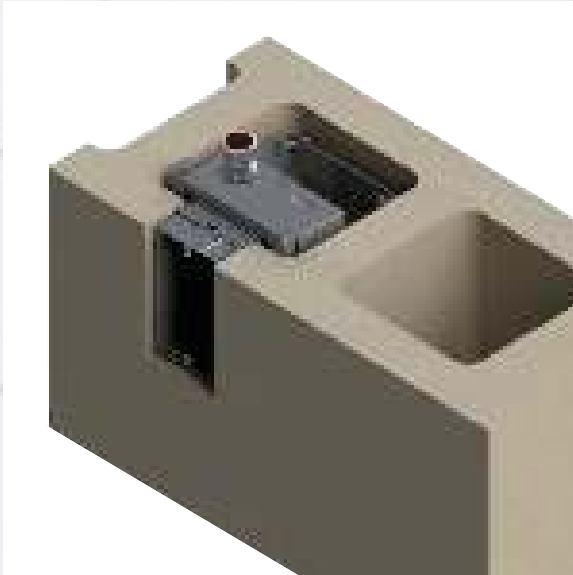

		PKG. QTY.	PG
FB816	Concrete Wall Bracket	25	FP271884
FB816-D-12CONN	½" EMT Connector	1	FP003697
FB816-D-34CONN	¾" EMT Connector	1	FP003698
FB816-D-1CONN	1" EMT Connector	1	FP003699



FAS POWER® ACCESSORIES

COVERS AND ADJUSTABLE RINGS

PLASTIC DEVICE COVERS

Attach to the front of receptacles, switches or can be snapped onto empty mud rings to keep them clean, dust free and finish ready during the taping and painting process. The covers are replaced later with faceplates at the trim out phase of construction.



	PKG. QTY.	BOX SIZE / DEVICE TYPE	FASTENERS INCLUDED	PL
DCP-1	50	SINGLE GANG RECEPTACLE	(2) #8-32 SCREWS	FP003414
DCP-2	50	DOUBLE GANG RECEPTACLE	(2) #8-32 SCREWS	FP003416
DCP-3	50	THREE GANG RECEPTACLE	(2) #8-32 SCREWS	FP003418
DCP-4	50	FOUR GANG RECEPTACLE	(2) #8-32 SCREWS	FP003420
DCP-1T	50	SINGLE GANG TOGGLE SWITCH	(2) #8-32 SCREWS	FP003415
DCP-2T	50	DOUBLE GANG TOGGLE SWITCH	(2) #8-32 SCREWS	FP003417
DCP-3T	50	THREE GANG TOGGLE SWITCH	(2) #8-32 SCREWS	FP003419
DCP-4T	50	FOUR GANG TOGGLE SWITCH	(2) #8-32 SCREWS	FP003421
DCP-DT	50	DBL. GANG TOGGLE SWITCH & DEVICE	(2) #8-32 SCREWS	FP003422
DCP-1R	50	SINGLE GANG PLASTER RING ONLY	NONE	FP231068
DCP-2R	50	DOUBLE GANG PLASTER RING ONLY	NONE	FP231071
DCP-3R	50	THREE GANG PLASTER RING ONLY	NONE	FP231074
DCP-4R	50	FOUR GANG PLASTER RING ONLY	NONE	FP231077
DCP-R	50	3" ROUND PLASTER RING ONLY	NONE	FP231080

ADJUSTABLE RINGS

Useful in installation where wall thicknesses are unknown at the time of order or electrical rough in.

Construction: Galvanized steel

	PKG. QTY.	BOX SIZE / DEVICE TYPE	FASTENERS INCLUDED	PG
APR-1-5/8	25	SINGLE GANG	5/8" TO 1 1/4"	FP211051
APR-1	25	SINGLE GANG	3/4" TO 1 1/2"	FP211050
APR-2	25	TWO GANG	3/4" TO 1 1/2"	FP211052
APR-3	25	THREE GANG	3/4" TO 1 1/2"	FP211053
APR-R	25	3-0 ROUND	3/4" TO 1 1/2"	FP211054

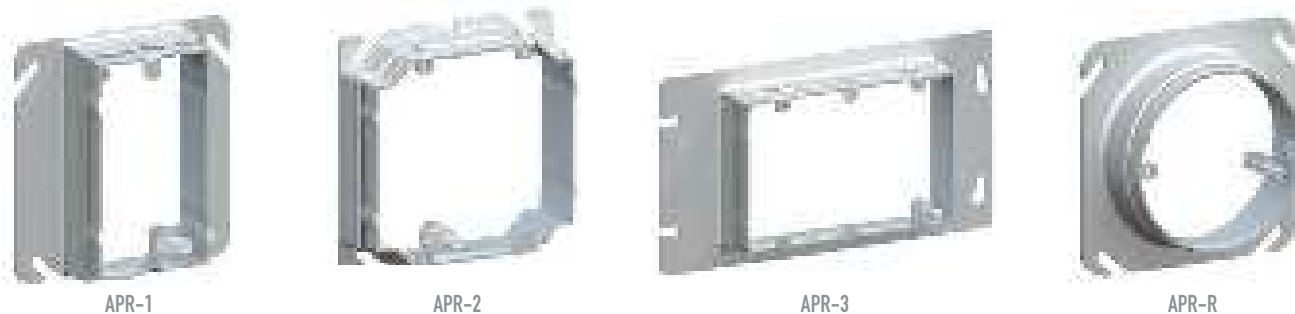

SUPPORT ARMS FOR FLOOR AND WALL BRACKETS

FIXED DEPTH SUPPORT ARMS

The FAS Power line includes 8 far side support arms for 3" depth to 6½" walls. Each snap easily onto any of our floor or wall brackets.

Construction: 18 gage pre-galvanized steel

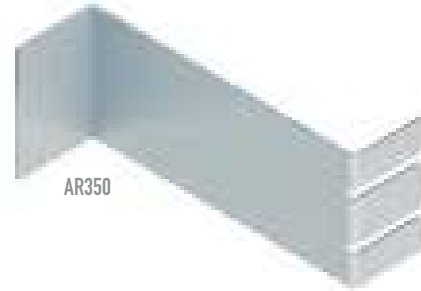

ADJUSTABLE SUPPORT ARM

The Adjustable Far Side Support Arm is perforated to make it easy to fit any sized wall depth to stabilize FAS Power Floor and Wall brackets. Just use a pliers to adjust. The AR250/600 fits wall depths from 2½" to 6" and reduces engineering time for job sites with varied stud sizes and wall depths. AR250/600 works with 2⅞" boxes only.

Construction: 18 gage pre-galvanized steel

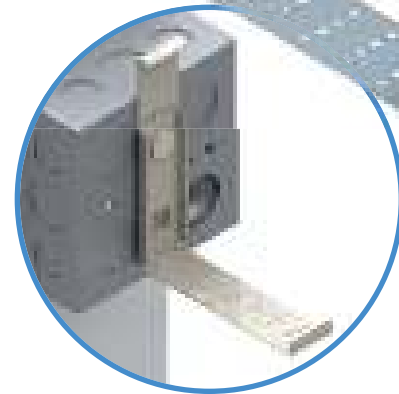
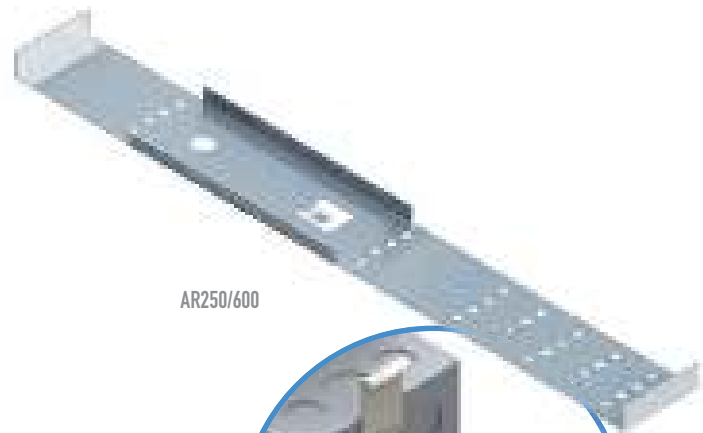

	PKG. QTY.	WALL DEPTH	PG
		INCHES	
AR250	50	2.5	FP211040
AR300	50	3	FP211041
AR350	50	3.5	FP211042
AR400	50	4	FP211043
AR450	50	4.5	FP211044
AR500	50	5	FP211045
AR600	50	6	FP211048
AR650	50	6.5	FP211049
AR250/600	50	2.5-6	FP211055

WALL BRACES FOR FLOOR BRACKETS

Wall braces stabilize FAS Power floor brackets where support arms are not an option. Available for 16" and 24" stud spacing.

Construction: Zinc-plated steel.

	PKG. QTY.	STUD SPACING	PG
		INCHES	
T16	50	16	FP211108
T24	50	24	FP211112

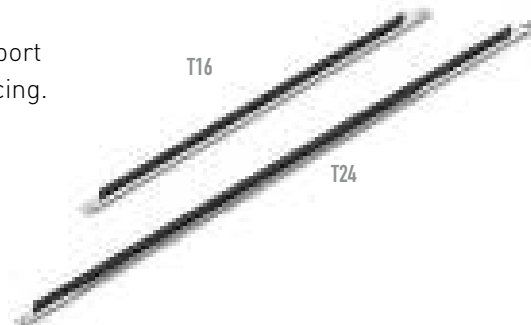

FAS POWER® ASSEMBLIES

Reduce your labor costs up to 50%

If you are looking to reduce your labor costs even more, consider pre-assembled FAS Power. Our plant will manufacture each assembly to your specifications for floor, wall or concrete block applications. FAS Power offers a wide variety of outlets, switches and wiring options, including precut lengths of MC cabling that arrive at the jobsite stripped and ready to install.

At Rough-in – simply install the electrical assembly. You can choose to have everything wired with a dust cover in place. All you do is make the connections with push-wire connectors.

At Finish – P&S Plugtail® offers contractors the flexibility allowing device and color choices to be made at the last minute due to changing color schemes.

To order FAS Power manufactured assemblies, use our online configurator to choose from over thousands of floor and wall options and hundreds of wiring options. It helps you:

1. Plan an assembly with a unique number
2. Create a submittal sheet for each assembly
3. Build a Bill of Material for ordering and inventory control

You can create a single assembly or the assemblies for an entire building. For more information visit: www.legrand.us/cablofil/fas-power and find out how FAS Power Manufactured Assemblies can benefit your bottom line!



P&S PlugTail® Wiring Devices – For profitable commercial installations.



PlugTail is the perfect compliment to FAS Power Manufactured Assemblies. It allows you to choose devices at the best time – at the end of the project.

At Rough-in – your productivity gains begin. Instead of making pigtails, simply connect the pre-stripped PlugTail connector leads. In one step, you're ready for device installation.

At Finish – Install devices in less than a minute. Just plug the connector into a PlugTail device. No preparing, stripping or looping conductors. No damaged devices or costly callbacks. P&S PlugTail installs three times faster than conventional devices.

P&S PlugTail devices are available in standard or decorator styles and in up to seven colors for any application.

- Specification Grade Receptacles and GFCI's
- Hospital Grade Receptacles and GFCI's
- Surge Protection Devices
- Single Pole and Three Way Toggle Switches
- Ratings for 15A and 20A
- Heavy Duty
- Tamper Resistant
- Isolated Ground



CABLOPORT®



Innovative solutions for rooftop support.

CabloPort is a UV and weather resistant rubber base that creates a cushion between rooftop mounted equipment and sensitive roofing materials. Available in two styles: Standard is perfect for smaller loads and tight spaces, and Widebody, with a broader base minimizing roof pressure and more area for glue application. CabloPort is available with pre-installed FAS P and Channel options for a variety of uses.

Non-Penetrating Weather Resistant Bases

- UV resistant rubber bases will not deteriorate over time
- Rubber base design supports up to 1000lb/ft
- Composite material accepts screws or other mechanical fasteners
- Made from 100% recycled rubber for green building certification

Preinstalled Metal Supports

- FAS P allows for easy installation of Cablofil cable management
- Slotted Channel supports PW ladder tray and tubing
- Supports are available in three finishes for exterior applications
- Options for sloped roofs and elevated pathways

Extends life of roof and improves safety

- Rubber base reduces pressure points on sensitive roofing materials
- Dampens vibrations from rooftop mounted equipment
- Reflective Safety Strip makes roof installations safer

- D.25 CP/CPW**
CABLOPORT
BASE ONLY
- D.26 CPP/CPS/CPWP/CPWS**
CABLOPORT BASE
w/ FAS P OR STRUT SUPPORT
- D.27 CPPE/CPSE/
CPWE/CPWSE**
CABLOPORT EXTENSION SERIES
w/ FAS P OR CHANNEL SUPPORT
- D.28 CPSMEP/CPWSME**
CABLOPORT MEDIUM LOAD
SERIES w/ CHANNEL SUPPORT
- D.29 CPPB/CPSB/
CPWPB/CPWSB**
CABLOPORT BRIDGE SERIES
w/ FAS P OR CHANNEL SUPPORT
- D.29 CPSA**
CABLOPORT VARI-ANGLE SERIES
w/ CHANNEL SUPPORT
- D.30 CPWGT/CPWGP**
CABLOPORT WIDEBODY BASE
w/ MEMBRANE
- D.30 CPWGT/CPWGPP/
CPWGT/CPWGPPS**
CABLOPORT WIDEBODY BASE
w/ MEMBRANE AND FAS P OR
CHANNEL SUPPORT
- D.31 CPPZ/CPSZ**
CABLOPORT SEISMIC SERIES

**CP/CPW
CABLOPORT BASE ONLY**

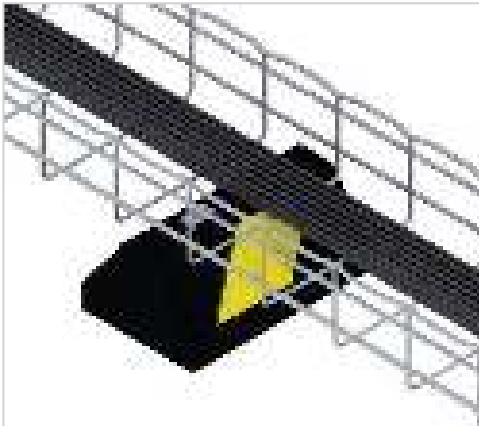

Standard Base (Curb Style)

CP10



Widebody Base
(Low Roof Pressure Style)

CPW12

- Cable pathway or other products mounted to base with clamps and screws.
- Install on any roofing material or other flat surface.
- Maximum Load 600 lbs.
- Widebody design has 1,000 lbs/ft maximum load and provides 5 times the surface to minimize roof material pressure, increase load capacity and provide over 120 square in/ft for glue application.
- Composite material allows through bolts or lag type screws (through bolts recommended)

	SUPPORT	HEIGHT		WIDTH		BASE LENGTH		WEIGHT		RBR*
		INCHES	MM	INCHES	MM	INCHES	MM	LBS	KG	
CP5	NONE	4.0	100	6.0	150	5.0	125	2.6	1.2	943 523
CP10		4.0	100	6.0	150	9.6	240	4.6	2.0	943 524
CP20		4.0	100	6.0	150	22.0	550	10.5	4.8	943 525
CP30		4.0	100	6.0	150	28.8	730	16.0	7.3	943 526
CPW12		3.0	75	12.0	300	12.0	300	9.5	4.3	943 714
CPW24		3.0	75	12.0	300	24.0	600	14.2	6.4	943 715
CPW36		3.0	75	12.0	300	36.0	900	18.9	8.6	943 716

*RBR= Rubber



CPP/CPS/CPWP/CPWS CABLOPORT BASE WITH FAS P OR STRUT SUPPORT

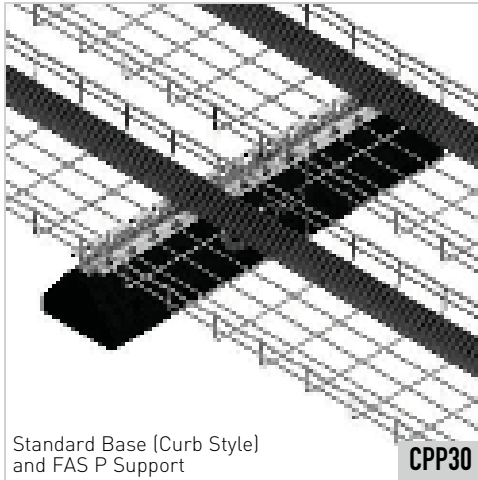
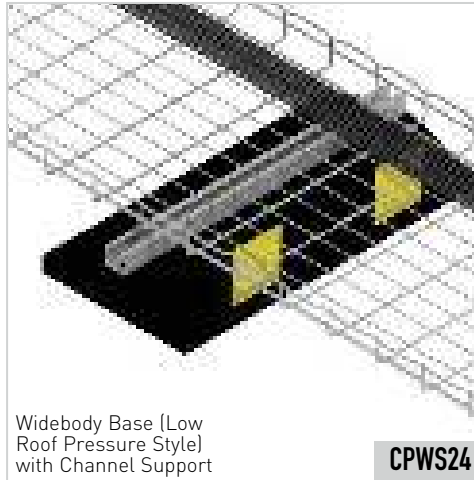

CPP30

CPWS24

- For support of tray, piping or other items on flat roofs.
- Two support styles: FAS Profile for Cablofil trays or 13/16" galvanized channel (14 ga.) for ladder tray, piping or other material support.
- Install on any roofing material or other flat surface.
- Supports are available in one standard finish and two optional finishes.
- Two rubber base designs: Standard Curb and Widebody style
- Widebody design has 1,000 lbs/ft maximum load and provides 5 times the surface area to minimize roof material pressure, increase load capacity and provide over 120 square in/ft for glue application.

	SUPPORT	HEIGHT		SUPPORT LENGTH		BASE LENGTH		WEIGHT		PG	GC	304L
		INCHES	MM	INCHES	MM	INCHES	MM	LBS	KG		STANDARD FINISH	OPTIONAL FINISHES
CPP5	FAS P	5.0	125	6.0	105	5.0	125	3.0	1.4	943 529	943 553	–
CPP10		5.0	125	12.0	300	9.6	240	5.0	2.3	943 530	943 554	–
CPP20		5.0	125	24.0	600	22.0	550	11.0	5.0	943 531	943 555	–
CPP30		5.0	125	30.0	750	28.8	730	18.5	8.4	943 532	943 556	–
CPS5	STRUT	5.0	125	6.0	105	5.0	125	3.0	1.4	943 534	–	–
CPS10		4.9	120	10.0	250	9.6	240	5.3	2.4	943 535	943 559	–
CPS15		4.9	120	16.0	400	14.6	370	8.6	3.9	943 536	943 560	–
CPS20		4.9	120	22.0	550	22.0	550	11.2	5.1	943 537	943 561	–
CPS30		4.9	120	28.0	710	28.8	730	16.3	7.4	943 538	943 562	–
CPWP12	FAS P	4.0	100	12.0	300	12.0	300	9.4	4.3	943 720	943 732	–
CPWP24		4.0	100	24.0	600	24.0	600	14.6	6.6	943 721	943 733	–
CPWP36		4.0	100	36.0	900	36.0	900	19.3	8.8	943 722	–	–
CPWS12	STRUT	3.75	95	12.0	300	12.0	300	10.0	4.5	943 738	943 750	–
CPWS24		3.75	95	24.0	600	24.0	600	14.7	6.7	943 739	943 751	–
CPWS36		3.75	95	36.0	900	36.0	900	19.5	8.8	943 740	943 752	–

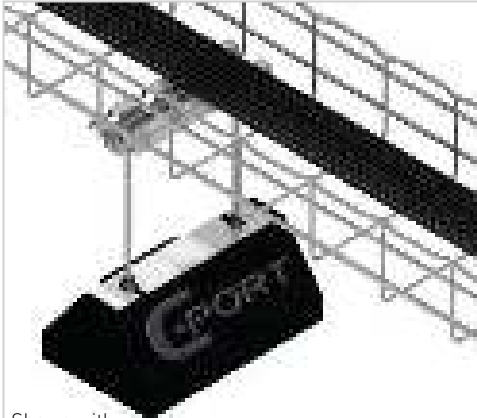
– Contact manufacturer for availability.

CPPE/CPSE/CPWPE/CPWSE CABLOPORT EXTENSION SERIES WITH FAS P OR CHANNEL SUPPORT



Shown with CFEP (Cablofil Extension Plate) increases load capacity to 500 lbs.

CPPE-88



CPWEPE12

- Height adjustable.
- For support of cable pathways with varying heights .
- Base includes two (2) 1/2" Electrozinc threaded rod risers and FAS Profile or channel.
- Supports are available in one standard finish and two optional finishes.
- Install on any roofing material.
- Standard series maximum load 150 lbs.
- Widebody design has maximum load of 500 lbs.
- Provides 5 times the surface area to minimize roof material pressure, increase load capacity and provide over 120 square in/ft for glue application.

	SUPPORT	HEIGHT		SUPPORT LENGTH		BASE LENGTH		WEIGHT		PG	GC	304L
		INCHES	MM	INCHES	MM	INCHES	MM	LBS	KG	STANDARD FINISH	OPTIONAL FINISHES	
CPPE10-88	FAS P	8.0	200	8.0	200	9.6	240	6.2	2.8	943 565	943 589	-
CPPE20-818		8.0	200	18.0	450	22.0	550	13.4	6.1	943 567	943 591	-
CPPE20-824		8.0	200	24.0	600	22.0	550	13.6	6.2	943 568	943 592	-
CPPE10-128		12.0	300	8.0	200	9.6	240	6.5	2.9	943 569	943 593	-
CPPE20-1218		12.0	300	18.0	450	22.0	550	13.9	6.3	943 571	943 595	-
CPPE20-1224		12.0	300	24.0	600	22.0	550	14.5	6.6	943 572	943 596	-
CPSE10-810	STRUT	8.0	200	10.0	250	9.6	240	6.2	2.8	943 601	943 625	-
CPSE20-822		8.0	200	22.0	550	22.0	550	13.7	6.2	943 603	943 627	-
CPSE30-828		8.0	200	28.0	710	28.8	730	19.4	8.8	943 604	943 628	-
CPSE10-1210		12.0	300	10.0	250	9.6	240	6.5	2.9	943 605	943 629	-
CPSE30-1228		12.0	300	28.0	710	28.8	730	19.6	8.9	943 608	943 632	-
CPWPE12-128	FAS P	12.0	300	8.0	200	12.0	300	10.4	4.7	943 756	-	-
CPWPE12-1212		12.0	300	12.0	300	12.0	300	10.6	4.8	943 757	-	-
CPWPE24-1218		12.0	300	18.0	450	24.0	600	17.5	8.0	943 758	-	-
CPWPE24-1224		12.0	300	24.0	600	24.0	600	17.8	8.1	943 759	-	-
CPWSE12-1210	STRUT	12.0	300	10.0	250	12.0	300	10.5	4.8	943 768	943 776	-
CPWSE12-1216		12.0	300	16.0	400	12.0	300	10.7	4.9	943 769	943 777	-
CPWSE24-1222		12.0	300	22.0	550	24.0	600	17.8	8.1	943 770	943 778	-
CPWSE24-1228		16.0	400	24.0	600	24.0	600	18.2	8.3	943 771	943 779	-

- Contact manufacturer for availability.



CPSME/CPWSME CABLOPORT MEDIUM LOAD SERIES WITH CHANNEL SUPPORT

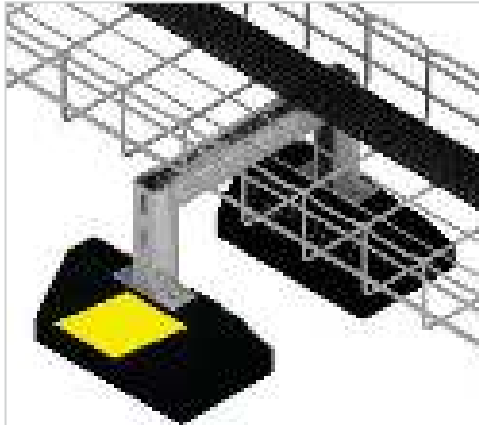

Standard Base (Curb Style)
with Channel Support

CPSME1020



Widebody Base
(Low Roof Pressure Style)
with Channel Support

CPWSME1224

- Ideal for mounting medium load elevated cable pathways.
- Base includes two channel risers and channel crossbar.
- Install on any roofing material or other flat surfaces.
- Supports are available in one standard finish and two optional finishes.
- Channel can be used to support Cablofil tray (secure with FS41 (SS) Spring Clips).
- Standard series maximum load 150/500 lbs.
- Widebody design has 1,000 lbs/ft maximum load and provides 5 times the surface area to minimize roof material pressure, increase load capacity and provide over 120 square in/ft for glue application.

	SUPPORT	HEIGHT		SUPPORT LENGTH		BASE LENGTH		WEIGHT		PG	GC	304L
		INCHES	MM	INCHES	MM	INCHES	MM	LBS	KG	STANDARD FINISH	OPTIONAL FINISHES	
	CPSME1020	10.0	250	20.0	500	10.0	250	14.2	6.4	943 669	943 677	–
	CPSME1620	16.0	400	20.0	500	10.0	250	15.6	7.1	943 670	943 678	–
	CPSME1030	10.0	250	30.0	750	22.0	550	45.0	20.4	943 671	943 679	–
	CPSME1630	16.0	400	30.0	750	22.0	550	45.5	20.6	943 672	943 680	–
	CPWSME1224	12.0	300	24.0	600	12.0	300	23.2	10.5	943 813	943 821	–
	CPWSME2424	24.0	600	24.0	600	12.0	300	25.7	11.5	943 814	943 822	–
	CPWSME1236	12.0	300	36.0	900	24.0	600	58.2	26.4	943 815	943 823	–
	CPWSME2436	24.0	600	36.0	900	24.0	600	60.4	27.4	943 816	943 824	–

– Contact manufacturer for availability.

CPPB/CPSB/CPWPB/CPWSB CABLOPORT BRIDGE SERIES WITH FAS P OR CHANNEL SUPPORT



Standard Base (Curb Style)
with Channel Support

CPSB10-28

- Designed as sleeper for HVAC units, cable pathways, roof walkways or other applications.
- Two (2) bases bridged with 1 5/8" galvanized channel (12 ga.) or FAS P.
- Install on any roofing material or other flat surfaces.
- Supports are available in one standard finish and two optional finishes.
- Channel can be used to support Cablofil tray (secure with FS41 Spring Clips).
- Standard series maximum load 500 lbs.
- Widebody design has 1,000 lbs/ft maximum load and provides five times the surface area to minimize roof material pressure, increase load capacity and provide over 120 square in/ft for glue application.

	SUPPORT	HEIGHT		SUPPORT LENGTH		BASE LENGTH		WEIGHT		PG	GC	304L
		INCHES	MM	INCHES	MM	INCHES	MM	LBS	KG	STANDARD FINISH	OPTIONAL FINISHES	
CPPB10-28	FAS P	5.0	125	28.0	710	9.6	240	13.4	6.1	943 637	–	–
CPSB10-28	STRUT	5.6	140	28.0	710	9.6	240	13.6	6.2	943 642	–	–
CPSB10-36		5.6	140	36.0	900	9.6	240	14.9	6.8	943 643	–	–
CPSB10-42		5.6	140	42.0	1050	9.6	240	–	–	943 644	–	–
CPSB10-50		5.6	140	50.0	1270	9.6	240	–	–	943 645	–	–
CPSB10-60		5.6	140	60.0	1524	9.6	240	–	–	943 646	–	–
CPWPB12-28		FAS P	5.0	125	28.0	710	12.0	300	22.2	10.1	944 434	–
CPWSB12-28	STRUT	5.6	140	28.0	710	12.0	300	22.5	10.2	944 431	944 580	–
CPWSB12-36		5.6	140	36.0	900	12.0	300	23.6	10.7	944 432	–	–
CPWSB12-42		5.6	140	42.0	1050	12.0	300	–	–	944 433	–	–
				42.0	1050	12.0	300	–	–	944 433	–	–

– Contact manufacturer for availability.

CPSA CABLOPORT VARI-ANGLE SERIES WITH CHANNEL SUPPORT



Standard Base (Curb Style)
with Channel Support

CPSA20PG

- Designed to adapt to any roof pitch or uneven surface.
- Install on any roofing material.
- Easily adjusted onsite.
- Leg adaptor will accommodate 1 5/8" x 1 5/8" channel framing.
- U-shaped 1 7/8" x 1 7/8" leg adaptor pre-drilled with 9/16" mounting holes is pre-mounted to base.
- Maximum load 500 lbs.

	SUPPORT	BASE HEIGHT		BASE WIDTH		BASE LENGTH		WEIGHT		PG
		INCHES	MM	INCHES	MM	INCHES	MM	LBS	KG	
CPSA10	STRUT	5.6	140	6.0	150	9.6	240	8.0	3.6	943 667
CPSA20		5.6	140	6.0	150	22.0	550	15.1	6.8	943 668

Vertical 1 5/8" x 1 5/8" strut and horizontal crossbar not provided.



CPWGT/CPWGP CABLOPORT WIDEBODY BASE WITH MEMBRANE



Widebody Base
(Low roof pressure Style)
with Membrane

CPW6T24

- For rooftop support of cable pathways or other products mounted to base with clamps or screws.
- Cable pathway is mounted to base with clamps and screws.
- Adhere membrane to TPO or PVC roofing material to reduce wind lift.
- Widebody design has no maximum load and provides 5 times the surface area on the roof to minimize roof material pressure, increase load capacity and provide over 120 square in/ft for glue application.

	MEMBRANE MTRL	SUPPORT	HEIGHT		WIDTH		BASE LENGTH		WEIGHT		RBR*
			INCHES	MM	INCHES	MM	INCHES	MM	LBS	KG	
CPWGT12	TPO	NONE	3.0	75	12.0	300	12.0	300	9.8	4.5	943 977
CPWGT24			3.0	75	12.0	300	24.0	600	14.5	6.6	943 978
CPWGT36			3.0	75	12.0	300	36.0	900	19.4	8.8	943 979
CPWGP12	PVC		3.0	75	12.0	300	12.0	300	9.8	4.5	943 989
CPWGP24			3.0	75	12.0	300	24.0	600	14.5	6.6	943 990
CPWGP36			3.0	75	12.0	300	36.0	900	19.4	8.8	943 991

*RBR= Rubber

CPWGT/CPWGP/CPWGT/CPWGP CABLOPORT WIDEBODY BASE WITH MEMBRANE AND FAS P OR CHANNEL SUPPORT



Widebody Base
(Low roof pressure Style)
with Membrane and FAS P Support

CPW6T24

- For rooftop support of cable pathways.
- Base includes FAS Profile or 13/16" galvanized channel (14 ga.).
- Adhere membrane to TPO or PVC roofing material to reduce wind lift.
- Supports are available in one standard finish and two optional finishes.
- Widebody design has no maximum load and provides 5 times the surface area on the roof to minimize roof material pressure, increase load capacity and provide over 120 square in/ft for glue application.

	MEMBRANE MTRL	SUPPORT	OVERALL HEIGHT		SUPPORT LENGTH		BASE LENGTH		WEIGHT*		PG	GC	304L
			INCHES	MM	INCHES	MM	INCHES	MM	LBS	KG	STANDARD FINISH	OPTIONAL FINISHES	
CPWGT12	TPO	FAS P	4.0	100	12.0	300	12.0	300	10.2	4.6	944 001	944 013	—
CPWGT24			4.0	100	23.6	595	24.0	600	14.4	6.5	944 002	944 014	—
CPWGT36			4.0	100	38.5	975	36.0	900	19.6	8.9	944 003	944 015	—
CPWGP12	PVC		4.0	100	12.0	300	12.0	300	10.2	4.6	944 037	944 049	—
CPWGP24			4.0	100	23.6	595	24.0	600	14.9	6.8	944 038	944 050	—
CPWGP36			4.0	100	38.5	975	36.0	900	19.6	8.9	944 039	944 051	—
CPWGT12	TPO	STRUT	3.75	95	12.0	300	12.0	300	10.3	4.7	944 073	944 085	—
CPWGT24			3.75	95	24.0	600	24.0	600	15.0	6.8	944 074	944 086	—
CPWGT36			3.75	95	36.0	900	36.0	900	19.6	8.9	944 075	944 087	—
CPWGPS12	PVC		3.75	95	12.0	300	12.0	300	10.3	4.7	944 109	944 121	—
CPWGPS24			3.75	95	24.0	600	24.0	600	15.0	6.8	944 110	944 122	—
CPWGPS36			3.75	95	36.0	900	36.0	900	19.6	8.9	944 111	944 123	—

— Contact manufacturer for availability.

CPPZ/CPSZ
CABLOPORT SEISMIC SERIES



Standard Seismic Base (Curb Style)
with FAS P Support

CPPZ10

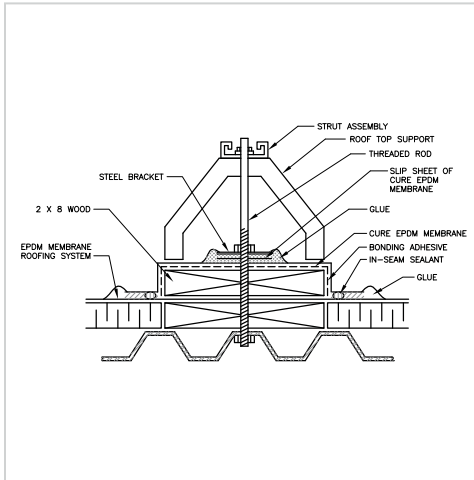

- Base includes FAS Profile or 13/16" galvanized channel (14 ga.).
- Designed for support of cable pathways and other rooftop equipment subject to seismic codes.
- This base includes a bolt that penetrates the roofing membrane and fastens to the underlining structure.
- Install on any roofing material or other flat surface.
- This product is approved by Carlisle SynTec Inc.
- Maximum load 750 lbs.
- Supports are available in one standard finish and two optional finishes.

	SUPPORT	OVERALL HEIGHT		BRKT WIDTH		BASE LENGTH		WEIGHT		PG	GC	304L
		INCHES	MM	INCHES	MM	INCHES	MM	LBS	KG	STANDARD FINISH	OPTIONAL FINISHES	
CPPZ10	FAS P	5.0	125	12.0	300	9.6	240	5.8	2.6	943 681	943 701	—
CPPZ20		5.0	125	24.0	600	22.0	550	11.7	5.3	943 682	943 702	—
CPPZ30		5.0	125	30.0	750	28.8	730	16.8	7.6	943 683	943 703	—
CPSZ10	STRUT	4.9	120	12.0	300	9.6	240	5.9	2.7	943 686	943 706	—
CPSZ20		4.9	120	24.0	600	22.0	550	11.8	5.4	943 687	943 707	—
CPSZ30		4.9	120	30.0	750	28.8	730	16.9	7.7	943 688	943 708	—

– Contact manufacturer for availability.



SEISMIC BRACING

SEISMIC BRACING KIT FOR LONG TRAY RUNS

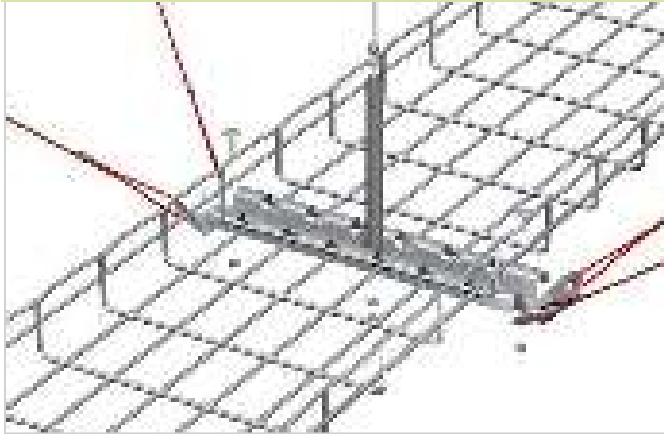

- Connect cables directly to 3/8" threaded rod in trapeze installations for seismic bracing.
- Use two EZ BN 3/8 (sold separately) to attach cables to FAS PCH for sway bracing.
- Pre-drilled tabs allow attachment directly to concrete deck.
- Spacing must be at least every 30'. For installation recommendations contact Cablofil Technical Services.

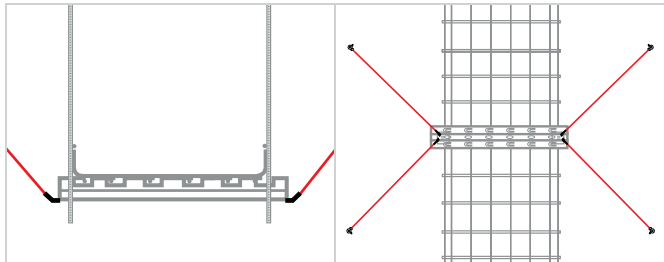

- Each kit contains:**
- (4) 11' cables with mounting eyelets
 - (2) Metal brackets for attachment to support members
 - (4) Cable clamp collars
 - (4) 3/8" x 3" wedge anchors

	LENGTH		WEIGHT		
	FT	M	LBS	KG	
SZMKIT	10.0	3	0.2	0.1	942 445

BULK WIRE ROPE/CABLE



PW-12-CBL



PW-18-CBL



PW-36-CBL



PW-48-CBL

COMPLETE CATALOG NO.	CABLE SIZE	BOX QTY.	DESCRIPTION
PW-12-CBL	12	250	(1) 250' SPOOL OF RED #12 CABLE
PW-18-CBL	18	250	(1) 250' SPOOL OF WHITE #18 CABLE
PW-36-CBL	36	250	(1) 250' SPOOL OF BLUE #36 CABLE
PW-48-CBL	48	250	(1) 250' SPOOL OF YELLOW #48 CABLE

UNIVERSAL RESTRAINT CLIPS



COMPLETE CATALOG NO.	CABLE SIZE	HOLE DIA.	DESCRIPTION
PW-URC-1/4P	ALL	1/4"	URC FOR 1/4" FASTENERS
PW-URC-3/8P	ALL	3/8"	URC FOR 3/8" FASTENERS
PW-URC-1/2P	ALL	1/2"	URC FOR 1/2" FASTENERS
PW-URC-5/8P	ALL	5/8"	URC FOR 5/8" FASTENERS
PW-URC-3/4P	ALL	3/4"	URC FOR 3/4" FASTENERS
PW-URC-7/8P	ALL	7/8"	URC FOR 7/8" FASTENERS

OVAL SLEEVES

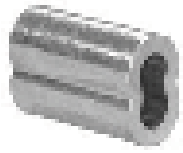

COMPLETE CATALOG NO.	CABLE SIZE	BOX QTY.	DESCRIPTION
PW-12-SLV	12	100	(1) BOX OF 100 #12 OVAL SLEEVES
PW-18-SLV	18	100	(1) BOX OF 100 #18 OVAL SLEEVES
PW-36-SLV	36	100	(1) BOX OF 100 #36 OVAL SLEEVES
PW-48-SLV	48	50	(1) BOX OF 50 #48 OVAL SLEEVES

ASSEMBLY TOOLS

COMPLETE CATALOG NO.	DESCRIPTION
PW-0-12-SBHS	(1) LOCOLOC HAND SWAGER FOR CRIMPING OVAL SLEEVES
PW-3-346-SBHS	(1) LOCOLOC LARGE SWAGER FOR CRIMPING OVAL SLEEVES

The Locoloc® Hand Swager IS THE CORRECT TOOL FOR THE JOB. It is capable of crimping all three sizes of oval sleeves for the braces in this manual. These tools are factory calibrated and are furnished with gauges and instructions to insure the proper crimping of oval sleeves. The Locoloc® Hand Swager is 26 inches long and weighs 6.5 pounds.

PW-C7	(1) FELCO CABLE CUTTER FOR #12 AND #18 CABLES
PW-C9	(1) FELCO CABLE CUTTER FOR #12 , #18 AND #36 CABLES



PW-0-12-SBHS

PW-3-346-SBHS



PW-C7



PW-C9

The Felco type C-7 and type C-9 Precision Cable Cutters are ideal for cutting and trimming excess cable. The C-7 cutter is 8 inches long, weighs 10 ounces and is used to cut size 12 and 18 cables with one hand. The type C-9 cutter is a two-handed tool that cuts all three cable sizes with ease.

NO PRY CLIP



COMPLETE CATALOG NO.	CABLE SIZE	HOLE DIA.	DESCRIPTION
PW-NPC-1/4P	ALL	¼"	NPC FOR ¼" FASTENERS
PW-NPC-3/8P	ALL	⅜"	NPC FOR ⅜" FASTENERS
PW-NPC-1/2P	ALL	½"	NPC FOR ½" FASTENERS
PW-NPC-5/8P	ALL	⅝"	NPC FOR ⅝" FASTENERS
PW-NPC-3/4P	ALL	¾"	NPC FOR ¾" FASTENERS
PW-NPC-7/8P	ALL	⅞"	NPC FOR ⅞" FASTENERS

SUPPORT ROD STIFFENER CLIPS

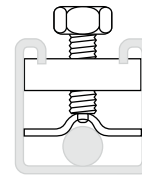

0602

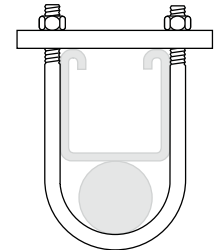

0603

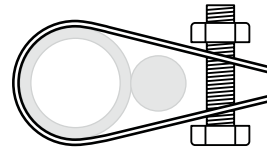

RS-1

See page D.38 for product details and requirements.

PRODUCT NUMBER	TYPE	ROD SIZE
0602	STRUT	⅜"-⅝"
0603	STRUT	¾"-1"
RS-1	PIPE	½"-1"



EARTHQUAKE SWAY BRACE SYSTEMS FOR CABLE TRAYS

Legrand has joined with Loos and Company, the industry's top manufacturer of Seismic Wire Rope/Cable™ Bracing, to provide a comprehensive and unique line of seismic protection products specifically designed for electrical cable tray applications. All our seismic Wire Rope/Cable™ bracing, complies with model building codes, and installs in just one-third the time needed for more conventional pipe, angle, and strut bracing systems. Our exclusive systems have no length limitation and are UL listed.

For more information go to www.legrand.us/cablofil and download our complete Seismic Bracing Catalog.

QUALITY CONSTRUCTION

Our standard braces are constructed of a splayed assembly of either 49 or 133 high strength, zinc coated, steel wires, configured into Wire Rope/Cable™.

PRE-STRETCHED ASSEMBLY DAMPENS SEISMIC LOADS

Our Wire Rope/Cable™ is pre-stretched to its maximum recommended working load. Pre-stretching allows our cable to act in its elastic range; in essence, it behaves like a shock absorber.

SPECIAL DESIGN & INSTALLATION FEATURES

Every brace is designed to resist earthquake loads in tension and they are not restricted in length as are compression braces. Standard braces are extremely flexible, lightweight and are offered in precut lengths, with or without fixed end fastener fittings.

FOUR STANDARD COLOR-CODED SIZES

Our standard braces are offered in three basic sizes, with minimum breaking strengths of 900, 1650, 4000 and 6600 Lbs. Each is color-coded in red, white, blue or yellow that insures proper designation on plans and for installation in the field.

QUALITY ASSURANCE & CERTIFIED BREAK STRENGTH

The manufacturer conducts a rigorous in-plant program of inspection, testing, and retesting of all its seismic Wire Rope/Cable™ products to meet code and industry standards. Loos & Co.'s Certificate of Minimum Breaking Strength is included with each shipment.

THE SEISMIC BRACING SYSTEM

Our seismic brace consists of four basic components: the Wire Rope/Cable™, a factory-attached stake eye end treatment, an oval sleeve used to secure the cable loop, and a universal restraint clip (URC). The seismic braces are pre-packaged with all of the parts needed to make a single 4-way sway brace. Hardware required to connect the cable tray to the braced component and to the building structure are not included in the brace packages.

THE WIRE ROPE/CABLE™			
BRACE SIZE	CABLE COLOR	CERTIFIED MINIMUM BREAK STRENGTH (LBS.)	ALLOWABLE LOAD (SAFETY FACTOR = 1.5)
12	RED	900	600
18	WHITE	1650	1100
36	BLUE	4000	2667
48	YELLOW	6600	4400

STAKE EYE

The stake eye attaches the seismic brace to the building structure and is available to fit 3/8" or 1/2" diameter hardware.

TOP VIEW



UNIVERSAL RESTRAINT CLIP (URC)

The "URC" Clip connects the Wire Rope/Cable™ brace to the cable tray support member. It will accommodate all three brace sizes and has hole diameters to fit hardware sizes from 1/4" to 1 1/4".

TOP VIEW

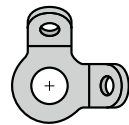

OVAL SLEEVE

The oval sleeve secures the cable loop through the URC clip. There are three sizes of oval sleeves, corresponding to the three brace sizes. The LOCOCLOC® hand swager tool is used to crimp the oval sleeves and is required to maintain brace strengths.

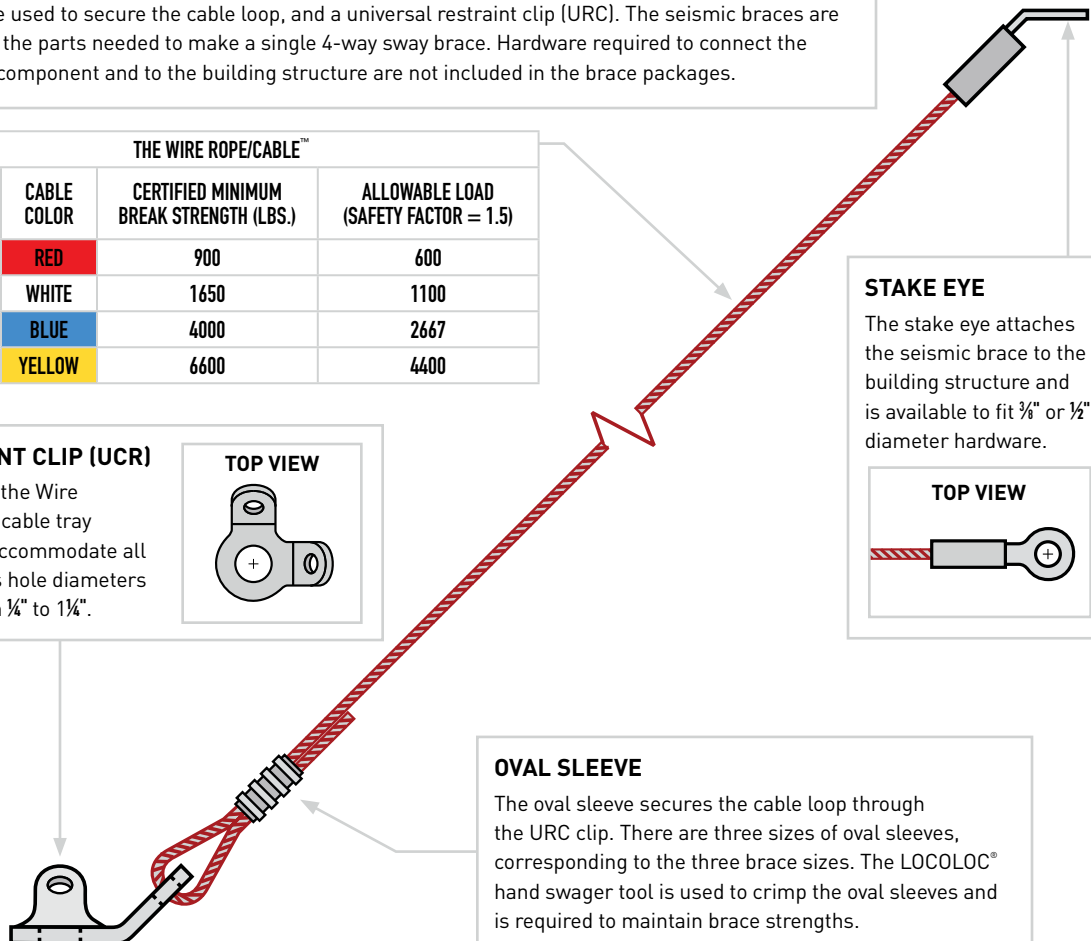

DESIGNING A SEISMIC BRACING SYSTEM

The following guidelines have been developed to aid in the process of designing seismic bracing systems for cable tray installations. This information is intended to serve as a recommendation only and users are cautioned to modify each installation as required to meet all federal, state, and local laws and regulations, which may supersede these recommendations. The design professional responsible for each project on which these braces are used must approve the bracing layout, the capability of the structural elements to which the braces are attached, and the use of the braces themselves along with their fasteners.

1. CALCULATE THE HORIZONTAL LOAD FACTOR (HLF) FOR THE INSTALLATION.

Each earthquake sway brace must be designed to resist the horizontal earthquake load/force within the brace zone of influence. The Horizontal Load Factor is the minimum portion or percentage of the cable tray system's total weight within the brace zone of influence, which must be resisted by the brace as applied in any horizontal direction.

The specific formula used to calculate the HLF, will be based upon the governing building code or standard for the installation. All codes and standards have somewhat different formulas for determining the horizontal load factor. Current codes and standards use a variety of factors, including the seismic zone for the region coefficients assigned to the building or component/system importance and/or performance level and anticipated responses to earthquake loads.

An Av activity level map and other information is available at: www.legrand.us/cablofil.

2. CALCULATE THE CABLE TRAY TOTAL LINEAR WEIGHT.

The loads that must be resisted by the seismic brace include the weight of the cable tray system and its contents. To do this, the total tray weight must be calculated and expressed in total pounds per linear foot. For multi-tier tray installations where only the bottom level of the tray is braced, the total weight of all tiers should be included in the calculation.

3. USE THE BRACING TABLES TO DETERMINE THE BRACE SIZES AND SPACING.

We have developed a series of bracing tables to simplify the selection of the correct brace size, brace spacing, and minimum fastener sizes. These tables tabulate this information according to the cable tray total linear weight versus the brace spacing for a given horizontal load factor and a minimum brace angle of 45 degrees from vertical. There are four bracing tables, each based on horizontal load factors of 0.25, 0.50 (shown at the bottom of this page), 0.75, and 1.00 respectively. Go to www.legrand.us/cablofil to find the bracing table that contains an HLF that meets or exceeds the HLF required for your application. Contact Legrand for a more precise calculation of your bracing needs.

4. SPECIFY COMPONENTS AND CATALOG NUMBERS

Refer to the Seismic Bracing Systems catalog on our website to generate component specifications, material lists and part numbers specific for the project. There are many important installation-specific factors to consider which include, but are not limited to, the following conditions:

1. The distance between the cable tray support and the various building structure components.
2. The type of cable tray to be installed
3. The type of cable tray supports to be installed.
4. Fastener types and attachment methods for making seismic brace-to-structure connections.
5. Whether or not the installation of the seismic braces will be concurrent with the installation of the cable tray supports, or retrofitted at a later time.

For more information relating to the conditions of your specific application go to: www.legrand.us/cablofil and download the Seismic Bracing Systems brochure.

CABLE TRAY TOTAL LINEAR WEIGHT (LBS./FT.)	HORIZONTAL EARTHQUAKE LOAD (LBS.) AND BRACE SIZE* BASED ON A HORIZONTAL LOAD FACTOR (HLF) OF ACCORDING TO BRACE SPACING AND CABLE TRAY TOTAL LINEAR WEIGHT																		0.50																	
	BRACE SPACING (FT.)																																			
	10			12			16			20			24			30			32			36			40											
	LOAD	A	B	C	LOAD	A	B	C	LOAD	A	B	C	LOAD	A	B	C	LOAD	A	B	C	LOAD	A	B	C	LOAD	A	B	C	LOAD	A	B	C				
10	50	12	3/8"	3/8"	60	12	3/8"	3/8"	80	12	3/8"	3/8"	100	12	3/8"	3/8"	120	12	3/8"	3/8"	150	12	3/8"	3/8"	160	12	3/8"	3/8"	180	12	3/8"	3/8"	200	12	3/8"	3/8"
20	100	12	3/8"	3/8"	120	12	3/8"	3/8"	160	12	3/8"	3/8"	200	12	3/8"	3/8"	240	12	3/8"	3/8"	300	12	3/8"	3/8"	320	12	3/8"	3/8"	360	12	3/8"	3/8"	400	12	3/8"	3/8"
30	150	12	3/8"	3/8"	180	12	3/8"	3/8"	240	12	3/8"	3/8"	300	12	3/8"	3/8"	360	12	3/8"	3/8"	450	18	3/8"	3/8"	480	18	3/8"	3/8"	540	18	3/8"	3/8"	600	18	3/8"	3/8"
40	200	12	3/8"	3/8"	240	12	3/8"	3/8"	320	12	3/8"	3/8"	400	12	3/8"	3/8"	480	18	3/8"	3/8"	600	18	3/8"	3/8"	640	18	3/8"	3/8"	720	18	3/8"	1/2"	800	18	3/8"	1/2"
50	250	12	3/8"	3/8"	300	12	3/8"	3/8"	400	12	3/8"	3/8"	500	18	3/8"	3/8"	600	18	3/8"	3/8"	750	18	3/8"	1/2"	800	36	3/8"	1/2"	900	36	3/8"	1/2"	1000	36	3/8"	1/2"
60	300	12	3/8"	3/8"	360	12	3/8"	3/8"	480	18	3/8"	3/8"	600	18	3/8"	3/8"	720	18	3/8"	1/2"	900	36	3/8"	1/2"	960	36	3/8"	1/2"	1080	36	3/8"	1/2"	1200	36	3/8"	1/2"
70	350	12	3/8"	3/8"	420	12	3/8"	3/8"	560	18	3/8"	3/8"	700	18	3/8"	3/8"	840	36	3/8"	1/2"	1050	36	3/8"	1/2"	1120	36	3/8"	1/2"	1260	36	1/2"	1/2"	1400	36	1/2"	1/2"
80	400	12	3/8"	3/8"	480	18	3/8"	3/8"	640	18	3/8"	3/8"	800	36	3/8"	1/2"	960	36	3/8"	1/2"	1200	36	3/8"	1/2"	1280	36	1/2"	1/2"	1440	36	1/2"	1/2"	1600	36	1/2"	1/2"
90	450	18	3/8"	3/8"	540	18	3/8"	3/8"	720	18	3/8"	1/2"	900	36	3/8"	1/2"	1080	36	3/8"	1/2"	1350	36	1/2"	1/2"	1440	36	1/2"	1/2"	1620	36	1/2"	1/2"	1800	36	1/2"	3/8"
100	500	18	3/8"	3/8"	600	18	3/8"	3/8"	800	36	3/8"	1/2"	1000	36	3/8"	1/2"	1200	36	3/8"	1/2"	1500	36	1/2"	1/2"	1600	36	1/2"	1/2"	1800	36	1/2"	5/8"	2000	X	1/2"	5/8"
110	550	18	3/8"	3/8"	660	18	3/8"	3/8"	880	36	3/8"	1/2"	1100	36	3/8"	1/2"	1320	36	1/2"	1/2"	1650	36	1/2"	1/2"	1760	36	1/2"	1/2"	1980	X	X	5/8"	2200	X	X	5/8"
120	600	18	3/8"	3/8"	720	18	3/8"	1/2"	960	36	3/8"	1/2"	1200	36	3/8"	1/2"	1440	36	1/2"	1/2"	1800	36	1/2"	5/8"	1920	X	1/2"	5/8"	2160	X	X	5/8"	2400	X	X	5/8"
130	650	18	3/8"	3/8"	780	36	3/8"	1/2"	1040	36	3/8"	1/2"	1300	36	1/2"	1/2"	1560	36	1/2"	1/2"	1950	X	1/2"	5/8"	2080	X	X	5/8"	2340	X	X	5/8"	2600	X	X	5/8"
140	700	18	3/8"	1/2"	840	36	3/8"	1/2"	1120	36	3/8"	1/2"	1400	36	1/2"	1/2"	1680	36	1/2"	1/2"	2100	X	X	5/8"	2240	X	X	5/8"	2520	X	X	5/8"	2800	X	X	5/8"
150	750	18	3/8"	1/2"	900	36	3/8"	1/2"	1200	36	3/8"	1/2"	1500	36	1/2"	1/2"	1800	36	1/2"	5/8"	2250	X	X	5/8"	2400	X	X	5/8"	2700	X	X	5/8"	3000	X	X	X

† Cable tray total linear weight is the combined weight of the cable tray and the installed cables.
 * Sway brace and fastener sizes (A, B, C) are based on a minimum brace angle from vertical of 45 degrees.
 A = V.S.T. UL Listed seismic Wire Rope/Cable™ brace size.
 B = Minimum bolt or hanger rod diameter for brace-to-tray connection and brace-to-structure connection.
 C = Minimum expansion shield diameter for brace anchorage to concrete structural element.
 X = Loads are too high for the brace assembly and/or fastener at this sway brace spacing.





Approved Fixed Equipment Anchorage
 California Office of Statewide Health Planning and Development (OSHPD)
 Based on CBC 2001 OPA-0619

City of Los Angeles Tested and Approved
 For all mechanical, plumbing and electrical piping, conduit, equipment and systems— including fire sprinklers

SEISMIC Wire Rope/Cable™ BRACING

Break Strength Certified - Color Coded - Prestretched

SWAY BRACE LOCATIONS AND SPACING

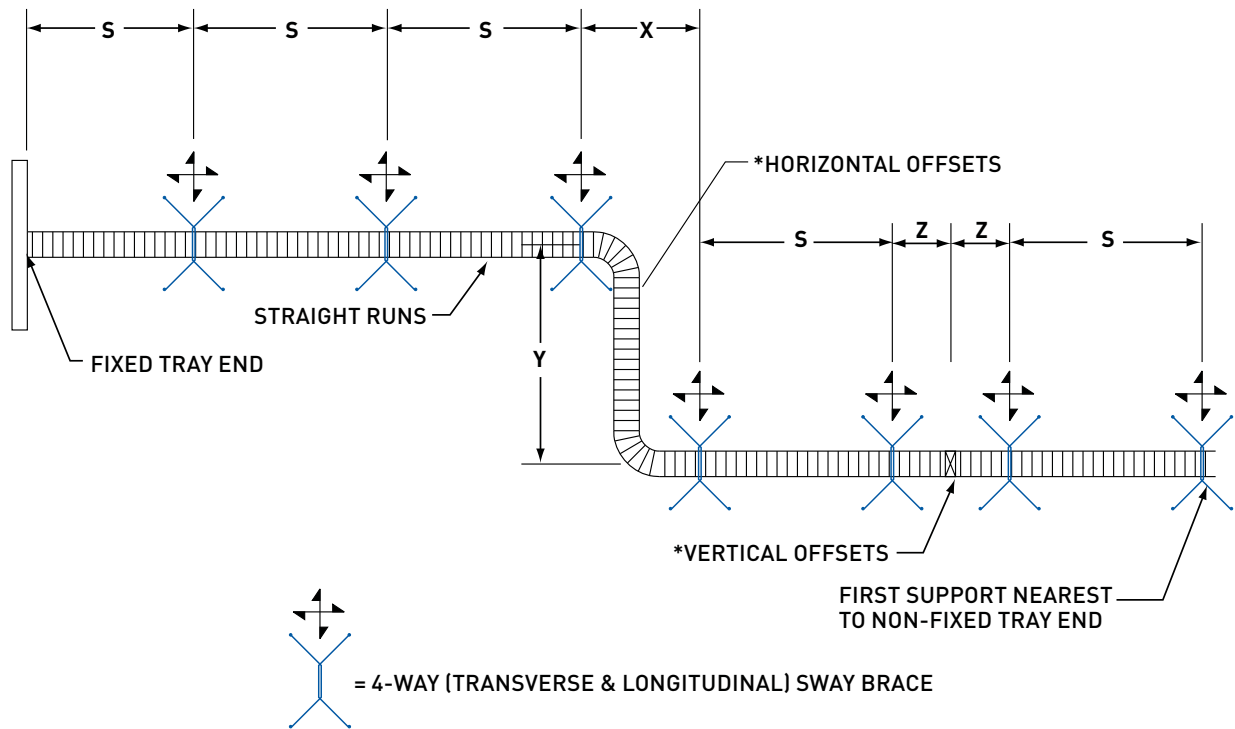

NOTES:

- (1) For horizontal offsets, a sway brace should be located at the cable tray support nearest to one end of the offset.
- (2) It is recommended that the max. Vertical offset without a sway brace be 30 feet and that the max. Spacing for sway braces on vertical trays should be 40 feet.

BRACED COMPONENT DESCRIPTION	MAXIMUM "S"	MAXIMUM "X" + "Y"	MAXIMUM "Z"
CABLE TRAY	40 FT.	40 FT.	5 FT.

Refer to specifications, V.S.T. manual and tables for brace spacing, required brace locations, load calculations procedures, sizing, and allowable loads on brace assemblies and fasteners.





Approved Fixed Equipment Anchorage

California Office of Statewide Health Planning and Development (OSHPD)
Based on CBC 2001 OPA-0619

City of Los Angeles Tested and Approved

For all mechanical, plumbing and electrical piping, conduit, equipment and systems—including fire sprinklers

SEISMIC Wire Rope/Cable™ BRACING

Break Strength Certified - Color Coded - Prestretched

COMBINATION TRANSVERSE / LONGITUDINAL EARTHQUAKE SWAY BRACE FOR PW INDUSTRIES (DOUBLE RAIL) CABLE TRAY

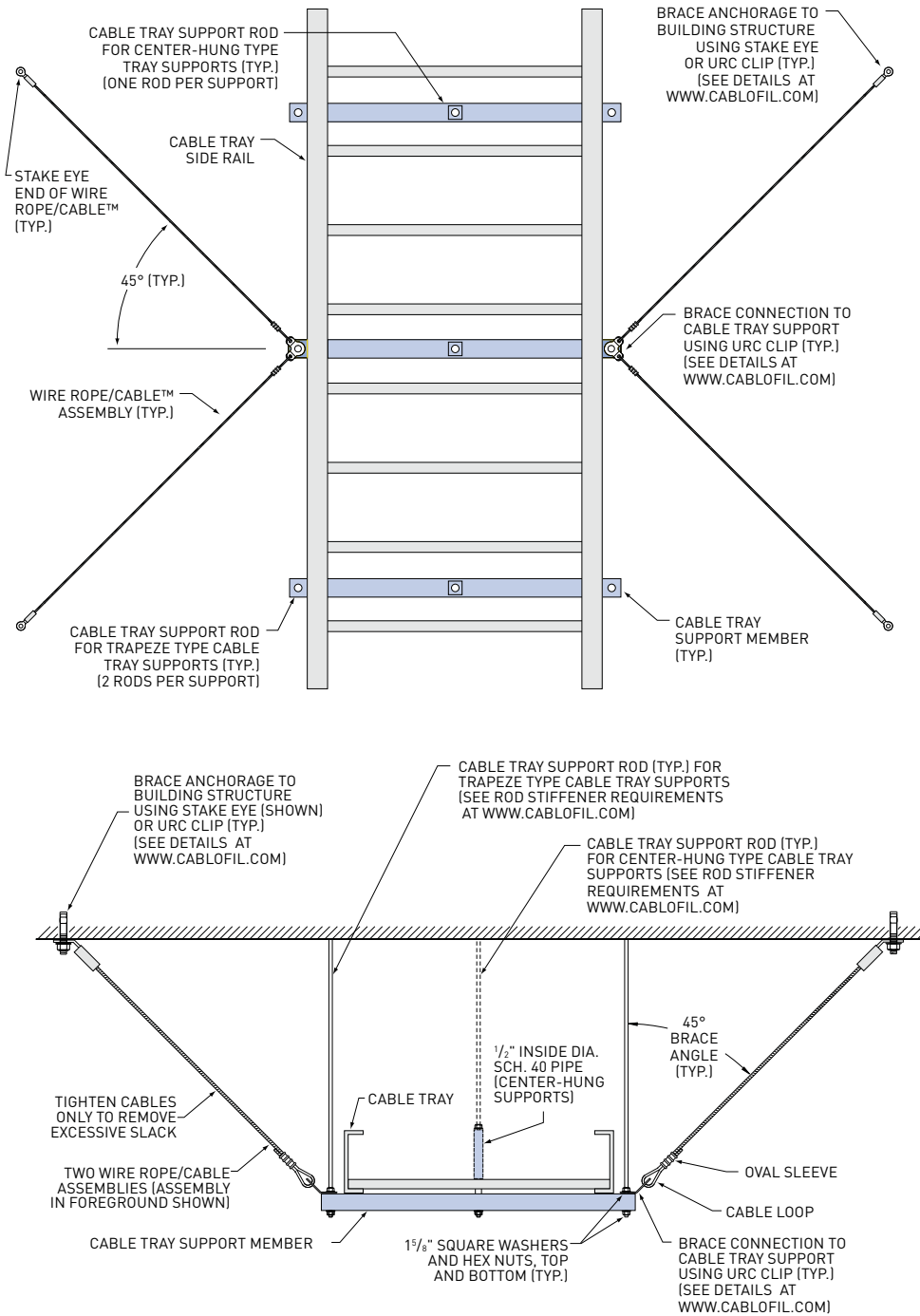

SEISMIC BRACING

Refer to specifications, V.S.T. manual and tables for brace spacing, required brace locations, load calculations procedures, sizing, and allowable loads on brace assemblies and fasteners.





Approved Fixed Equipment Anchorage

California Office of Statewide Health Planning and Development (OSHPD)
Based on CBC 2001 OPA-0619

City of Los Angeles Tested and Approved

For all mechanical, plumbing and electrical piping, conduit, equipment and systems—including fire sprinklers

SEISMIC Wire Rope/Cable™ BRACING

Break Strength Certified - Color Coded - Prestretched

SUPPORT ROD STIFFENER DETAILS AND REQUIREMENTS (AT SWAY BRACE LOCATIONS ONLY)

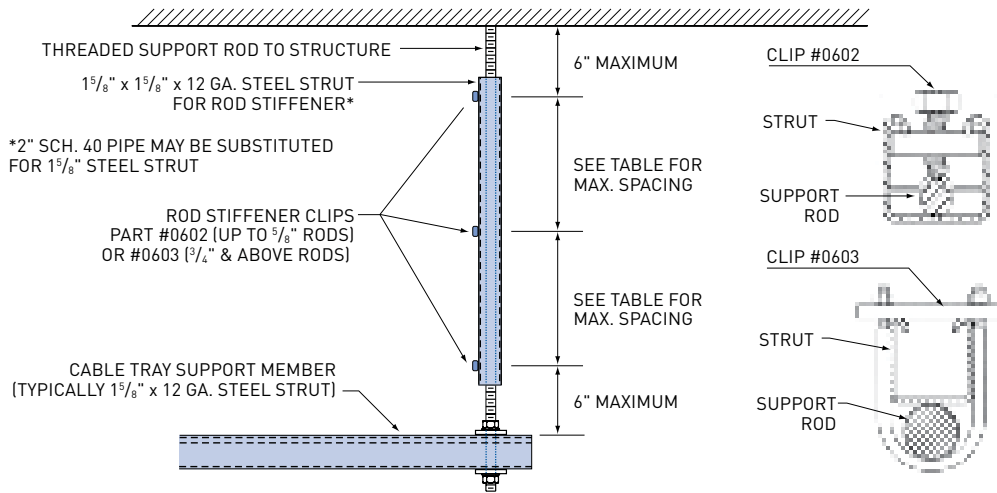

MAXIMUM ROD LENGTH WITHOUT STIFFENER	
ROD DIA.	MAXIMUM LENGTH
3/8"	16
1/2"	22
5/8"	28
3/4"	34
7/8"	40
1"	46
MAXIMUM SPACING OF ROD STIFFENER CLIPS	
ROD DIA.	MAXIMUM SPACING
3/8"	13
1/2"	18
5/8"	23
3/4"	28
7/8"	33
1"	38

1. Maximum allowable length of 1 5/8" x 1 5/8" x 12 ga. steel strut for rod stiffener is 9'-0".
2. For support rods 9'-1" to 13'-1", sleeve the support rod with 2" schedule 40 pipe.
3. For multi-tier support systems, the steel strut rod stiffener shall be installed such that it be secured to the side of the bottom support member, in contact with the structure, and held in position by securing to the side of one other horizontal support member, using the rod stiffener clips shown above.

SAMPLE DETAILS OF CABLE BRACE ANCHORAGE TO STRUCTURE FOR CABLOFIL CABLE TRAY

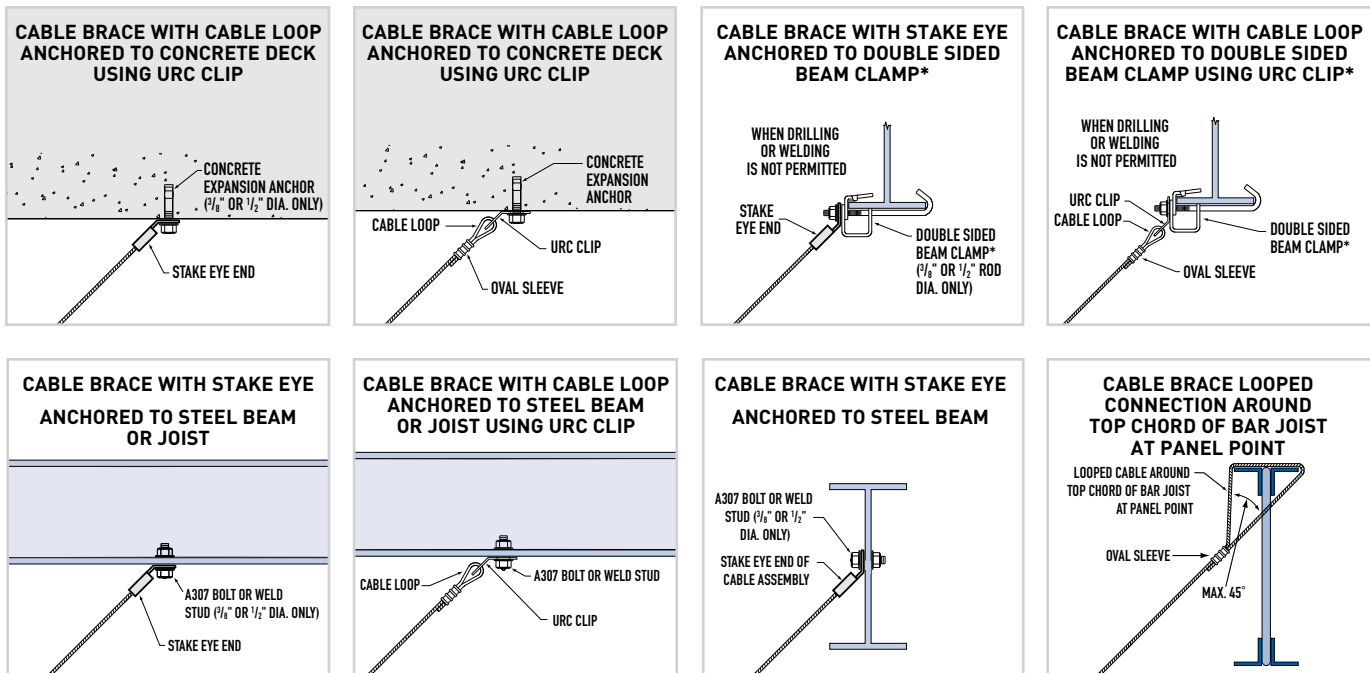

(*MIN. CLAMP ROD DIA. PER COL. 'B' OF BRACING TABLES)

NOTE: Refer to specifications, V.S.T. manual and tables for brace spacing, required brace locations, load calculations procedures, sizing, and allowable loads on brace assemblies and fasteners.

SEISMIC BRACING

LEGRAND

PRODUCT NUMBER INDEX

A WIRE MESH

AB225 KIT 70
 AS 43
 BH75KIT 63
 C 50 35, 51, 69
 C50CC 67
 CABLEXIT 72
 CABLEXIT50 65
 CAT 30 37
 CAT 41 37
 CC KIT 67
 CE 25 25
 CE 30 25
 CE 35 25
 CE 40 24
 CE40CC 68
 CF 105 13
 CF 150 13
 CF 30 12
 CF 54 12
 CFG 15
 CFL 15
 CH 68
 CLIP 74
 CLIP F02 17
 CM50I 69
 COT 105 19
 COT 150 19
 COT 30 19
 COT 54 19
 COT F 18
 COT J 19
 COTFIL50 18
 COTFIL100 18
 COUPFIL 84
 CUTYFIL 85
 CRP 35
 CS 34, 45
 CSC 34, 44
 CTXF 35 16
 CVN 17
 DF 47, 53
 DO 72
 DROP OUT KIT 73
 EAC KIT 26
 ED 275 23
 EDF 33, 46, 53
 EDRN 21, 86
 EDRNT00L 21
 EDRSKIT 22
 EDT 23
 ERD 10 47
 EXPANKIT 22
 EZJB 5/16 75
 EZT 90 KIT 26
 EZT9ORS 61
 EZVC 74
 FAS C 31, 44

FAS L 30, 52
 FAS P 29, 42, 50
 FAS PCH 41
 FAS ROLLER 76
 FAS U 32, 52
 FASLOCK 26
 FASROLLER HD 77
 FCF 54 17
 FLAMESTOPPER 78
 FS 41 71
 FV 29
 GNDCL 75
 GNDSB 75
 HB 2 KIT 70
 HTB 62
 HXB 62
 INSERT 16
 INSERTPP 63
 MFM 73
 OTDO 64
 OTDOFAS 64
 PACKCF 14
 PAT 30 40
 PFREDF 47
 PRECLICK 21
 PROCS 43
 PS 45
 RADT 90 KIT 27
 RADT 9012 KIT 27
 RADT9ORS 61
 RB112KIT 74
 RHXB 62
 SAS 40
 SBDA 69
 SF 100 39
 SF 50 39
 SON 42
 SWK 24
 TC4KIT 68
 TC5KIT 68
 TOH 65
 TXF 35 16
 UC 35 16
 UC 50 36, 51
 UFC 49
 UFC550 KIT 49
 UFCF2 57
 UFCN 50
 UFFS 55
 UFS 54, 56, 58, 59
 UFSCB 56
 UFSUPKIT 56
 UFT 90° KITS 57
 WMC2LA 71
 WTSB 30
 YCKIT 71
 ZF 150 13
 ZF 30 12

B LADDER TRAY

0010-99 78
 0012-99 49
 0109 34, 73
 0112 34, 73
 0118 34, 73
 0124 34, 73
 0130 34, 73
 0136 34, 73
 0215 55
 0216 55
 0226 56
 0228 56
 0253 51, 84
 0254 51, 78, 94
 0327 95
 0328 95
 0331 95
 0333 85
 0334 85
 0339 93
 0341 85
 0345 95
 0349 94
 0353 55
 0356 47, 77
 0357 86
 0369 54
 0371 54
 0373 54
 0385 79
 0386 79
 0387 79
 0392 55
 0393 54
 0394 54
 0395 54
 0401 37
 0402 51, 78, 84
 0403 47, 85, 94
 0410 94
 0424 51
 0426 93
 0434 51
 0440 58
 0606 49, 78
 0709 34, 73
 0712 34, 73
 0718 34, 73
 0724 34, 73
 0730 34, 73
 0736 34, 73
 0809 34, 73
 0812 34, 73
 0818 34, 73
 0824 34, 73
 0830 34, 73
 0836 34

0836 34, 73
 0925 44
 0926 44
 0930 50
 0941 78
 0950 57
 1000 42, 89
 1007 42
 1012 36, 74, 84
 1024 36, 74, 84
 1036 36, 74, 84
 1066 42
 1085 81
 1104 42
 1114 42
 1124 40
 1140 42
 1301 86
 1302 45, 77, 93
 1303 46
 1304 46
 1305 47, 77, 86
 1307 47, 77, 86
 1314 46, 77
 1320 46, 77, 93
 1331 93
 1335 45
 1338 85
 1355 45
 1357 86
 1379 45
 1385 45
 1386 45
 1400 43, 76, 81
 1410 44
 1411 43
 1423 43
 1423 76
 1432 44
 1440 43
 1441 44, 76
 1442 44, 76
 1443 44
 1444 44
 1508 81
 1509 81
 1753 28
 1754 28
 1755 28
 1756 28
 1772 28
 1803 85
 1811 79
 1812 85
 1818 57
 1852 50
 1853 44
 1864 47

1864 77
 1866 52, 79
 1867 52
 1870 87
 1871 87
 1872 87
 1873 56
 1893 52, 79
 1899 53
 1916 56
 1952 26
 1953 26
 1954 26
 1069 28
 1070 28
 1080 28
 1081 28
 1082 28
 1083 28
 1E45 28
 1E46 28
 1E53 28
 1E54 28
 1E72 28
 1F45 28
 1F46 28
 1F53 28
 1F54 28
 2000 42, 89
 2002 42
 2006 42
 2007 42
 2012 34, 35, 74, 84
 2024 34, 35, 74, 84
 2036 34, 35, 74, 84
 2066 42
 2067 42
 2085 81
 2104 42
 2112 42
 2114 42
 2124 40
 2140 42
 2224 40
 2508 81
 2509 81
 3000 42
 3002 42
 3003 42
 3005 42
 3012 33, 72, 82
 3014 81
 3017 42
 3024 33, 72, 82
 3029 42
 3036 33, 42, 72, 82
 3038 42
 3039 42

3040 42
 3041 42
 3042 42
 3050 42
 3070 42
 3076 42
 3095 81
 30HB 13
 30VI 18
 30VO 17
 3112 39, 42, 75, 83
 3112-99 49, 78
 3113 42
 3117 42
 3124 39, 75, 83
 3124-99 49, 78
 3128 42
 3131 42
 3136 39, 75, 83
 3136-99 49, 78
 3212 38, 75, 83
 3212-99 49, 78
 3224 38, 75, 83
 3224-99 49, 78
 3236 38, 75, 83
 3236-99 49, 78
 3406 30
 3407 30
 3408 30
 3409 30
 3416 30
 3417 30
 3445 30
 3446 30
 3456 30
 3476 30
 3504 30
 3505 30
 3514 30
 3515 30
 3528 81
 3529 81
 3532 81
 3538 81
 3550 30
 3551 30
 3582 30
 3583 30
 3587 30
 3592 30
 3593 30
 3594 30
 3603 30
 3604 30
 3620 30
 3621 30
 3645 30
 3701 30



3714.....	30	6136.....	39, 83	A810.....	48	USP.....	22	PROCS.....	18	DS-8520.....	9
3722.....	30	6136-99.....	49	A814.....	48	USPB.....	22	THRD.....	25	DS-8524.....	9
3723.....	30	6212.....	38, 83	A823.....	95	VASP.....	23	THRDPT.....	25	DS-8532.....	9
3724.....	30	6212-99.....	49	A824.....	95	VHSP.....	22	VT.....	9	DS-8570.....	9
3734.....	30	6224.....	38, 83	A836.....	53	VX.....	19			DS-8575.....	9
3735.....	30	6224-99.....	49	A837.....	53	WMC 2LA.....	52	D FASTENERS		DS-8594.....	9
3738.....	30	6236.....	38, 83	A838-01.....	95	WPS.....	25	0602.....	33	DS-8595.....	9
3739.....	30	6236-99.....	49	A839-01.....	95	YL.....	16	0603.....	33	DS-8596.....	9
3754.....	30	6A12C.....	10	A840-01.....	56	YR.....	16	APR.....	20	DS-8598.....	9
3756.....	30	6A20B.....	10	A842-01.....	95			AR.....	21	DS-8644.....	9
3760.....	30	6A20C.....	10	A843-01.....	95			CABLO SNAP.....	11	DS-8845.....	9
3D58.....	30	6A24C.....	10	A844-01.....	95	G TROUGH TRAY		CCLMP.....	11	DS-8938.....	9
3D63.....	30	7130.....	76	A845.....	52	A838.....	18	CJ TREES.....	8	ETC.....	10
3D82.....	30	7134.....	88	BE.....	24	A839.....	18	CJ12.....	4	EZBC.....	10
3D85.....	30	7400.....	70	BJ.....	48	BTRCC6X12.....	25	CJ21.....	4	EZ CN.....	9
3D92.....	30	7508.....	88	COTJ.....	50	CA.....	25	CJ32.....	4	EZ FW.....	9
3D93.....	30	7509.....	88	CS.....	19	COT 54.....	23	CJ64.....	4	EZ HN.....	9
3F35.....	30	7615.....	70	DIV.....	24	COT 105.....	23	CJ16HP.....	6	F112.....	15
3F58.....	30	7625.....	70	DO.....	24	COT J.....	23	CJ32HP.....	6	F115.....	15
3F61.....	30	7A12C.....	10	DS-1841.....	40	CS.....	18	CJ48HP.....	6	F118.....	15
3F66.....	30	7A20B.....	10	DS-8524.....	48	CSC.....	18	CJ4T125.....	7	F124.....	15
3F67.....	30	7A20C.....	10	DS-8530.....	48	DF.....	20	CJ4T2.....	7	F212.....	15
3F68.....	30	7A24C.....	10	DS-8575.....	48	ECLI.....	25	CJHP TREES.....	8	F215.....	15
3F85.....	30	7D20.....	70	DS-8576.....	48	EDF.....	19	CP.....	25	F218.....	15
4024.....	37	7F20.....	70	DS-8596.....	48	ERD 10.....	20	CPW.....	25	F224.....	15
4124.....	37	7F24.....	70	DS-8600.....	48	EZ BN.....	25	CPP.....	26	F312.....	15
4512.....	33, 72, 82, 88	8104.....	91	DS-8926.....	48	EZ CN.....	25	CPPB.....	29	F315.....	15
4524.....	33, 72, 82, 88	8106.....	91	DS-8927.....	48	EZ FW.....	25	CPPE.....	27	F318.....	15
4536.....	33, 72, 82, 88	8200.....	78	DS-8930.....	50	EZ HN.....	25	CPPZ.....	31	F324.....	15
45HB.....	13	8204.....	91	DS-8935.....	76, 78, 87	FAS U.....	19	CPS.....	26	F418.....	15
45VI.....	18	8206.....	91	DS-8954.....	87	FT.....	8	CPSA.....	29	FASCLM KIT.....	10
45V0.....	17	8945.....	53	ET.....	15	FTAS.....	17	CPSB.....	29	FB816.....	19
4612.....	39, 75, 83, 89	9012.....	32, 72, 82, 88, 92	EXSP.....	22	FTB.....	14	CPSE.....	27	FB816-D-12CONN.....	19
4612-99.....	49, 78	9024.....	32, 72, 82, 88	F-1852.....	78	FTBC.....	14	CPSME.....	28	FB816-D-34CONN.....	19
4624.....	39, 75, 83, 89	9036.....	32, 72, 82, 88	FCC.....	21	FTBE.....	24	CPSZ.....	31	FB816-D-1CONN.....	19
4624-99.....	49, 78	90HB.....	12	FFSP.....	23	FTBP.....	24	CPW.....	25	FS 41.....	11
4636.....	39, 75, 83, 89	90SP.....	23	FOSP.....	22	FTCC.....	22	CPWP.....	26	PW-C7.....	33
4636-99.....	49, 78	90SP.....	23	FWPS.....	25	FTCF.....	22	CPWGP.....	30	PW-C9.....	33
4712.....	38, 75, 83, 89	90VI.....	18	HASP.....	23	FTCFCL.....	21	CPWGPP.....	30	PW-CBL.....	32
4712-99.....	49, 78	90VO.....	17	HT.....	14	FTCH.....	17	CPWGPS.....	30	PW-NPC.....	33
4724.....	38, 75, 83, 89	9112.....	39, 75, 83, 89, 92	HX.....	16	FTCHC.....	17	CPWGT.....	30	PW-SBH.....	33
4724-99.....	49, 78	9112-99.....	49, 78	IP34.....	24	FTEF.....	11	CPWGTP.....	30	PW-SLV.....	33
4736.....	38, 75, 83, 89	9124.....	39, 75, 83, 89	LFF.....	20	FTFB45.....	12	CPWGTS.....	30	PW-URC.....	32
4736-99.....	49, 78	9124-99.....	49, 78	LR.....	14	FTCFB45.....	12	CPWPB.....	29	RS-1.....	33
4812.....	26	9136.....	39, 75, 83, 89	OCK.....	25	FTFB90.....	12	CPWPE.....	27	SON.....	9
4823.....	26	9136-99.....	49, 78	OHCB.....	25	FTCFB90.....	12	CPWS.....	26	SZMCKIT.....	32
4904.....	26	9212.....	38, 75, 83, 89, 92	ORSP.....	23	FTFCL.....	21	CPWSB.....	29	T16.....	21
4A12B.....	10	9212-99.....	49, 78	P-0949-01.....	57	FTHDCL.....	21	CPWSE.....	27	T24.....	21
4A12C.....	10	9224.....	38, 75, 83, 89	PCC.....	21	FTLHR.....	11	CPWSME.....	28	THRD.....	9
4A20B.....	10	9224-99.....	49, 78	PCT.....	21	FTP31CL.....	24	CWTBB.....	16	THRDPT.....	9
5088.....	81	9236.....	38, 75, 83, 89	RHSP.....	24	FTRB.....	18	CWTSB.....	16	W1.....	17
5508.....	81	9236-99.....	49, 78	RR.....	14	FTRHR.....	11	DCP.....	20	W16SSL.....	17
5509.....	81	9312.....	40	RT.....	15	FTT.....	14	DS-0102.....	9	W2.....	17
5A12C.....	10	9324.....	40	RX.....	16	FTTC.....	14	DS-0103.....	9	W24SSL.....	17
5A20B.....	10	9336.....	40	SFF.....	20	FTUMP.....	22	DS-0113.....	9	W3.....	17
6012.....	32, 82	A457.....	28	SON 1/2.....	57, 87	FTUS.....	10	DS-0113.....	9	W34.....	17
6024.....	32, 82	A639.....	28	SON 1/4.....	57, 87	FTVI90.....	13	DS-0113.....	9	W4.....	17
6036.....	32, 82	A802.....	53	SON 3/8.....	57, 87	FTCVI90.....	13	DS-0221.....	9		
60HB.....	12	A803.....	48	SPF.....	20	FTVO90.....	13	DS-0237.....	9		
60VI.....	18	A804.....	48	SR.....	14	FTCV090.....	13	DS-0255.....	9		
60VO.....	17	A805.....	48	SRSP.....	23	FTVT.....	15	DS-0256.....	9		
6112.....	39, 83	A806.....	48	SSP.....	22	FTX.....	15	DS-0257.....	9		
6112-99.....	49	A807.....	48	TBC.....	24	FTXC.....	15	DS-8502.....	9		
6124.....	39, 83	A808.....	48	TD.....	19	JP.....	24	DS-8510.....	9		
6124-99.....	49	A809.....	48	TU.....	19	PFREDF.....	20	DS-8515.....	9		



designed to be better.™

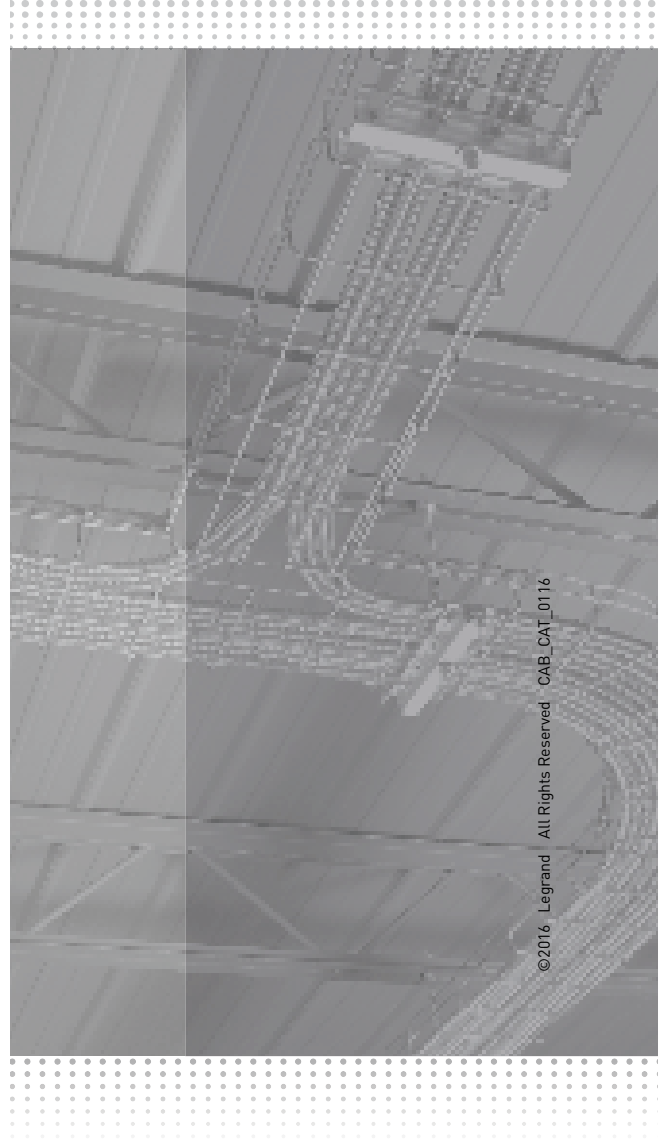

©2016 Legrand All Rights Reserved CAB_CAT_0116



Electrical Wiring Systems

8319 State Route 4
Mascoutah, IL 62258
800.658.4641
www.legrand.us/cablofil

570 Applewood Crescent
Vaughan, Ontario L4K 4B4
905.738.9195
www.legrand.ca

FOLLOW US

