

Swifts[®] cable ladder

building on innovation



PRODUCT TECHNICAL GUIDE /
INCLUDING SWIFTRACK
AND SUPPORTING SYSTEMS

CONTENTS



INTRODUCTION

Swifts cable ladder features	2
Legrand worldwide	4
Sustainable development	4
UK manufacturing, design and accreditation	5
Case studies	6
Intergraph	7

PRODUCT SELECTION

SWIFTS CABLE LADDER SYSTEMS

Selection charts	10-13
Straight lengths, couplers and fittings	
Medium duty (Topaz)	14-15
Heavy duty (Sapphire)	16-17
Extra heavy duty (Emerald)	18-19
Supports	20
Ancillary items	21-23
Covers	23
Fasteners	24

SWIFTRACK CHANNEL SUPPORT SYSTEM

Channel and channel nuts	25
Cantilever arms	26
Framework brackets, clamps and accessories	27-28
Standard fixings and fasteners	29-30

CEILING SUPPORT SYSTEM

Heavy duty	31
------------	----

TECHNICAL SPECIFICATIONS

SWIFTS CABLE LADDER SYSTEMS

Straight lengths	34-36
Rung details	37
Diagonal bracing	37
Couplers – straight lengths	38-42
Pre-fabrication of cable ladder runs	43
Identification and recognition of fittings	43
Couplers – fittings	44-45
Flat bends	46-49
Inside and outside risers	50-61
Equal tees	62
Unequal tees	63-68
Branch pieces	69
4 way crosspieces	70-71
Reducers – straight / offset	72-73
Supports	74-78
Ancillary items	79-94
Covers	95-98

SWIFTRACK CHANNEL SUPPORT SYSTEM

Single channels – plain and slotted	99
Back-to-back channels	100
Assembly – fasteners and channel nuts	101
Cantilever arms	102-103
Framework brackets	104-107
Beam clamps, pipe clamps and accessories	107-108

CEILING SUPPORT SYSTEM

Heavy duty	109
------------	-----

DESIGN NOTES

Selecting the right finish	112-117
Finishes	118-121
Installation of services	122-131
Structural support characteristics	132-139
Packaging, handling, storage and safety	140-141
Relevant British standards	142-143

Swifts[®] cable ladder... faster by design

An established favourite in the UK and abroad, this comprehensive system of slotted rail cable ladder enables the coupling of lengths and fittings without the need for drilling... with fewer components and a wealth of innovative time-saving installation features, Swifts cable ladder remains the market leader



Fewer components... greater time savings!

Continual product development and design innovation means that Swifts cable ladder is over 50% faster to install when connecting fittings to lengths...

- Integral couplers on all fittings
- Number of required fastener sets halved
- Two part quick-fit fasteners – 50% fewer fixing components



Save time... save money!

The long-term success of Swifts cable ladder is built on design innovation and time-saving features that put us yet another rung ahead of the rest!

The inclusion of **integral couplers on all ladder fittings** used together with our **quick-fit fasteners** more than halves the number of required fixings and dramatically cuts installation time and cost. Supplied as standard on all Topaz, Sapphire and Emerald fittings, this coupling technique benefits every installation type, from medium duty right through to extra heavy duty.

Time-saving innovations reduce man hours and energy usage on site, including fewer components for improved assembly times



PRODUCT RANGES

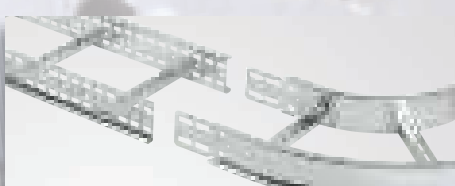

TOPAZ - MEDIUM DUTY

- Generally suitable for spans up to 3 m
- Side rail height: 100 mm
- Available cabling space: 69 mm
- Supplied as standard in 3 m lengths
- Finishes: G (hot dip galvanised), D (deep galvanised) and S (stainless steel)

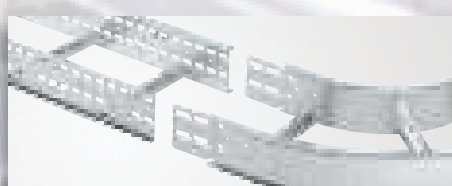

SAPPHIRE - HEAVY DUTY

- Generally suitable for spans up to 3.5 m
- Side rail height: 125 mm
- Available cabling space: 94 mm
- Supplied as standard in 3 m lengths (lengths up to 6 m available on request)
- Finishes: G (hot dip galvanised), D (deep galvanised), S (stainless steel) and E (powder coated)



EMERALD - EXTRA HEAVY DUTY

- Generally suitable for spans up to 4 m
- Side rail height: 150 mm
- Available cabling space: 119 mm
- Supplied as standard in 3 m lengths (lengths up to 6 m available on request)
- Finishes: G (hot dip galvanised), D (deep galvanised) and S (stainless steel)

Legrand - global strength built on local knowledge

With a 15% share of the global market, the Legrand Group is the world specialist in cable management systems... and with our established Swifts, Salamandre and Arena-Walsall ranges, our cable management division has a firm leadership position in the UK.



Sustainable development

From design through to manufacturing, the Legrand Group selects materials and processes that respect people and the environment.

- Efficient and environmentally aware product design
- Product functions that help to avoid energy waste
- Management of manufacturing and logistics sites
- Integration of environmental concerns and ISO 14001 procedures at the Group's global sites. *

* 84% of sites are ISO 14001:2004 accredited including all UK sites.



Legrand in the UK - powered by specialists

In the UK Legrand has developed a customer focused structure which harnesses the power of its market leading specialist brands to deliver innovative, integrated solutions for every phase of construction.

Quality assured UK manufacturing



Swifts cable management ranges have been designed and manufactured at our Scarborough (UK) site since the 1960's. And with its own in-house galvanising facility, every product is finished to the highest possible standard following strict quality control guidelines.



Legrand Electric holds ISO 9001 : 2008 Quality Assessment Registrations from Intertek Systems Certification UK and Bureau Veritas



All of Legrand's UK manufacturing sites are accredited to ISO 14001 : 2004 Environmental Management System



Support from design to installation

With in-depth knowledge and experience, our expert cable management team provides customers with support and advice for any installation... including bespoke solutions (specials) from our in-house design team that can cope with the most demanding requirements for the most challenging projects.

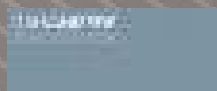

Legrand - the cable management experts

Trusted for installations large and small

Swifts cable ladder has been tried and tested in installations of all sizes throughout the UK and beyond, from medium duty requirements in small commercial buildings through to extra heavy duty installations in refineries and heavy industry applications.

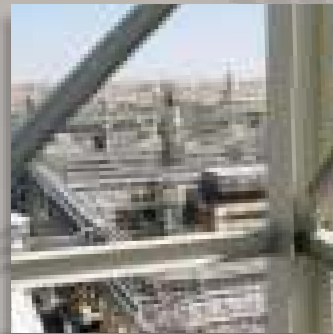

Cable management project examples

Process, power and marine

- Tengiz Second Generation - Kazakhstan
- Vesta Wind Turbine Manufacturing Plant - Isle of Wight
- Norilisk Nickel Slag Cleaning Furnaces Upgrade - Siberia
- Ling Au Nuclear Plant - China
- Shell EA and KC upgrades - Nigeria
- Dukhan Facilities Upgrade - Qatar
- Clare Offshore Platform - Shetlands
- Eggborough Power Station - UK

Transport and infrastructure

- Dublin Airport - Ireland
- Dubai Airport - Dubai
- Kings Cross regeneration - London
- Channel Tunnel Rail Link - UK/France
- Millau Viaduct - France
- Tyne Tunnel - UK
- Heathrow T2/T3/T4/T5 - UK
- National Convention Centre Car Park - Qatar

General

- MOD, Corsham - Wiltshire
- Grand Mosque - Dubai
- Hong Kong Jockey Club - Hong Kong
- Landmark Tower - Dubai
- St. Davids II - Cardiff, Wales
- Diwan Al Amiri Utility Building - Qatar
- Arcapita Bank - Bahrain
- Tianjin Electronics Plant - China

Specification data for Intergraph, AVEVA and Bentley engineering software systems

As part of our ongoing commitment to customer support, Legrand's Swifts cable ladder and cable tray ranges are now integrated into the following plant design modelling systems :

- Intergraph's PDS and Smartplant 3D
- AVEVA's PDMS
- Bentley Systems' BBES and BRCM

For many industries, achieving higher production goals within budget constraints and strict regulatory requirements is a challenging prospect. Applying engineering software allows for a high quality, fast-build, maintainable system which offers full workflow managed integration across the entire project enterprise.

Using a library of intelligent Swifts cable ladder and cable tray product models inside a highly productive 3D design software system allows design teams to produce accurate and efficient cable management routing schemes, plans and procurement lists as a fully integrated part of the overall plant design.

Key benefits include :

- Whole plant lifecycle from FEED (Front End Engineering Design), detailed design and construction through to handover, full operation and beyond
- Database driven applications manage all of the engineering information in one location
- Intelligent rules and relationships including clash detection features
- High project visibility and review functionality creating more efficient and productive operations
- High performance 3D visuals giving interactive walkthrough and realism features
- Making the best use of global design teams leading to concurrent engineering





PRODUCT SELECTION





IN THIS SECTION

SWIFTS CABLE LADDER SYSTEMS

Selection charts 10-13

Medium duty (Topaz)

Straight lengths	14
Couplers – straight lengths	14
Couplers – fittings	14
Flat bends	14
Inside and outside risers	14
Equal tees	15
Unequal tees	15
Branch pieces	15
4 way crosspieces	15
Straight reducers	15
Offset reducers	15

Heavy duty (Sapphire)

Straight lengths	16
Couplers – straight lengths	16
Couplers – fittings	16
Flat bends	16
Inside and outside risers	16
Equal tees	17
Unequal tees	17
Branch pieces	17
4 way crosspieces	17
Straight reducers	17
Offset reducers	17

Extra heavy duty (Emerald)

Straight lengths	18
Couplers – straight lengths	18
Couplers – fittings	18
Flat bends	18
Inside and outside risers	18
Equal tees	19
Unequal tees	19
Branch pieces	19
4 way crosspieces	19
Straight reducers	19
Offset reducers	19

Supports 20

Ancillary items 21-23

Covers 23

Fasteners 24

SWIFTRACK CHANNEL SUPPORT SYSTEM

Channel and channel nuts 25

Cantilever arms 26

Framework brackets, clamps and accessories 27-28

Standard fixings and fasteners 29-30

CEILING SUPPORT SYSTEM

Heavy duty 31

Swifts® medium duty (Topaz) and heavy duty (Sapphire) cable ladder systems

MEDIUM DUTY (TOPAZ)

	LADDER		COUPLERS			FITTINGS ⁽¹⁾				
	Widths (mm)	Straight lengths (3 m) F = finish	Coupler sets F = finish	Fitting to fitting coupler sets F = finish	Fitting to straight length fastener sets ⁽¹⁾ F = finish	Flat bends A = angle r = radius F = finish	Inside risers A = angle r = radius F = finish	Outside risers A = angle r = radius F = finish	Equal tees r = radius F = finish	Unequal tees B = branch r = radius F = finish
MEDIUM DUTY (TOPAZ)										
	150	ZL 150 F	ZC F	ZFC F	LF F M10P50	ZFB 150 ArF	ZIR 150 ArF	ZOR 150 ArF	ZT 150 r R F	ZUT 150 Br R F
	300	ZL 300 F	ZC F	ZFC F	LF F M10P50	ZFB 300 ArF	ZIR 300 ArF	ZOR 300 ArF	ZT 300 r R F	ZUT 300 Br R F
	450	ZL 450 F	ZC F	ZFC F	LF F M10P50	ZFB 450 ArF	ZIR 450 ArF	ZOR 450 ArF	ZT 450 r R F	ZUT 450 Br R F
	600	ZL 600 F	ZC F	ZFC F	LF F M10P50	ZFB 600 ArF	ZIR 600 ArF	ZOR 600 ArF	ZT 600 r R F	ZUT 600 Br R F
	750	ZL 750 F	ZC F	ZFC F	LF F M10P50	ZFB 750 ArF	ZIR 750 ArF	ZOR 750 ArF	ZT 750 r R F	ZUT 750 Br R F
900	ZL 900 F	ZC F	ZFC F	LF F M10P50	ZFB 900 ArF	ZIR 900 ArF	ZOR 900 ArF	ZT 900 r R F	ZUT 900 Br R F	

HEAVY DUTY (SAPPHIRE)

	LADDER		COUPLERS			FITTINGS ⁽¹⁾				
	Widths (mm)	Straight lengths (3 m) ⁽²⁾ F = finish	Coupler sets F = finish	Fitting to fitting coupler sets F = finish	Fitting to straight length fastener sets ⁽¹⁾ F = finish	Flat bends A = angle r = radius F = finish	Inside risers A = angle r = radius F = finish	Outside risers A = angle r = radius F = finish	Equal tees r = radius F = finish	Unequal tees B = branch r = radius F = finish
HEAVY DUTY (SAPPHIRE)										
	150	PL 150 F	PC F	PFC F	LF F M10P50	PFB 150 ArF	PIR 150 ArF	POR 150 ArF	PT 150 r R F	PUT 150 Br R F
	300	PL 300 F	PC F	PFC F	LF F M10P50	PFB 300 ArF	PIR 300 ArF	POR 300 ArF	PT 300 r R F	PUT 300 Br R F
	450	PL 450 F	PC F	PFC F	LF F M10P50	PFB 450 ArF	PIR 450 ArF	POR 450 ArF	PT 450 r R F	PUT 450 Br R F
	600	PL 600 F	PC F	PFC F	LF F M10P50	PFB 600 ArF	PIR 600 ArF	POR 600 ArF	PT 600 r R F	PUT 600 Br R F
	750	PL 750 F	PC F	PFC F	LF F M10P50	PFB 750 ArF	PIR 750 ArF	POR 750 ArF	PT 750 r R F	PUT 750 Br R F
900	PL 900 F	PC F	PFC F	LF F M10P50	PFB 900 ArF	PIR 900 ArF	POR 900 ArF	PT 900 r R F	PUT 900 Br R F	

(1) When connecting fittings to straight lengths, use fastener sets (not available in D finish) LFGM10P50, LFSM10P50, see p. 24
 (2) 6 m lengths available on special request, contact us on +44 (0) 845 605 4333

FITTINGS ⁽¹⁾				
Branch piece F = finish	4 way crosspieces r = radius F = finish	Straight reducers K = reduced width F = finish	Offset reducers (left hand) K = reduced width F = finish	Offset reducers (right hand) K = reduced width F = finish
ZB 150 300 R F	ZX 150 r R F	-	-	-
ZB 300 300 R F	ZX 300 r R F	ZSR 300 K F	ZLR 300 K F	ZRR 300 K F
ZB 450 300 R F	ZX 450 r R F	ZSR 450 K F	ZLR 450 K F	ZRR 450 K F
ZB 600 300 R F	ZX 600 r R F	ZSR 600 K F	ZLR 600 K F	ZRR 600 K F
ZB 750 300 R F	ZX 750 r R F	ZSR 750 K F	ZLR 750 K F	ZRR 750 K F
ZB 900 300 R F	ZX 900 r R F	ZSR 900 K F	ZLR 900 K F	ZRR 900 K F

Key : selecting medium duty (Topaz) fittings

Replace the letters shown in red with your choice from the following options :

A = Angle (°) : 90, 60, 45 or 30

B = Branch width (mm) : 150, 300, 450, 600, 750, 900

F = Finish : G (hot dip galvanised after manufacture)
D = (deep galvanised), S (stainless steel)

K = Narrowed width when using a reducer (mm) : 150, 300, 450, 600, 750

r = Radius (mm) : 300, 600

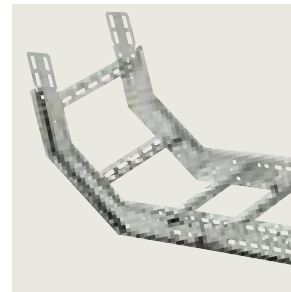
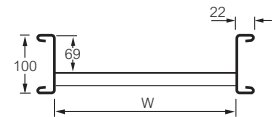

Inside risers. See p. 14

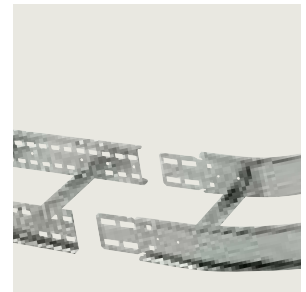

Flat bends. See p. 14

FITTINGS ⁽¹⁾				
Branch piece F = finish	4 way crosspieces r = radius F = finish	Straight reducers K = reduced width F = finish	Offset reducers (left hand) K = reduced width F = finish	Offset reducers (right hand) K = reduced width F = finish
PB 150 300 R F	PX 150 r R F	-	-	-
PB 300 300 R F	PX 300 r R F	PSR 300 K F	PLR 300 K F	PRR 300 K F
PB 450 300 R F	PX 450 r R F	PSR 450 K F	PLR 450 K F	PRR 450 K F
PB 600 300 R F	PX 600 r R F	PSR 600 K F	PLR 600 K F	PRR 600 K F
PB 750 300 R F	PX 750 r R F	PSR 750 K F	PLR 750 K F	PRR 750 K F
PB 900 300 R F	PX 900 r R F	PSR 900 K F	PLR 900 K F	PRR 900 K F

Key : selecting heavy duty (Sapphire) fittings

Replace the letters shown in red with your choice from the following options :

A = Angle (°) : 90, 60, 45 or 30

B = Branch width (mm) : 150, 300, 450, 600, 750, 900

F = Finish : G (hot dip galvanised after manufacture),
D (deep galvanised), S (stainless steel),
E (powder coated)

K = Narrowed width when using a reducer (mm) :
150, 300, 450, 600, 750

r = Radius (mm) : 300, 600

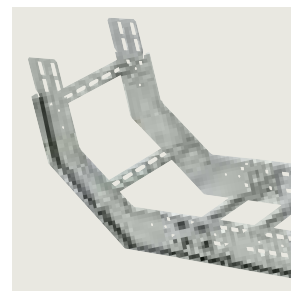
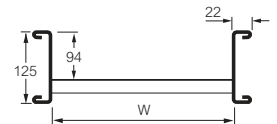

Inside risers. See p. 16

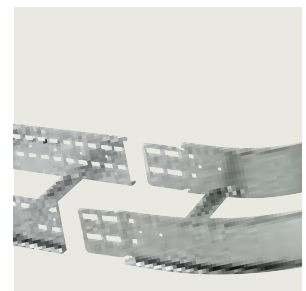

Flat bends. See p. 16

Swifts® extra heavy duty (Emerald)

cable ladder systems

EXTRA HEAVY DUTY (EMERALD)

	LADDER		COUPLERS		FITTINGS ⁽¹⁾					
	Widths (mm)	Emerald straight lengths (3 m) ⁽²⁾ F = finish	Coupler sets F = finish	Fitting to fitting coupler sets F = finish	Fitting to straight length fastener sets ⁽¹⁾ F = finish	Flat bends A = angle r = radius F = finish	Inside risers A = angle r = radius F = finish	Outside risers A = angle r = radius F = finish	Equal tees r = radius F = finish	Unequal tees B = branch r = radius F = finish
EXTRA HEAVY DUTY (EMERALD)	150	EL 150 F	EC F	EFC F	LF FM10P50	EFB 150 ArF	EIR 150 ArF	EOR 150 ArF	ET 150 rRF	EUT 150 BrRF
	300	EL 300 F	EC F	EFC F	LF FM10P50	EFB 300 ArF	EIR 300 ArF	EOR 300 ArF	ET 300 rRF	EUT 300 BrRF
	450	EL 450 F	EC F	EFC F	LF FM10P50	EFB 450 ArF	EIR 450 ArF	EOR 450 ArF	ET 450 rRF	EUT 450 BrRF
	600	EL 600 F	EC F	EFC F	LF FM10P50	EFB 600 ArF	EIR 600 ArF	EOR 600 ArF	ET 600 rRF	EUT 600 BrRF
	750	EL 750 F	EC F	EFC F	LF FM10P50	EFB 750 ArF	EIR 750 ArF	EOR 750 ArF	ET 750 rRF	EUT 750 BrRF
	900	EL 900 F	EC F	EFC F	LF FM10P50	EFB 900 ArF	EIR 900 ArF	EOR 900 ArF	ET 900 rRF	EUT 900 BrRF

(1) When connecting fittings to straight lengths, use fastener sets (not available in D finish) LFGM10P50, LFSM10P50, see p. 24

(2) 6 m lengths available on special request, contact us on +44 (0) 845 605 4333

FITTINGS⁽¹⁾

Branch piece F = finish	4 way crosspieces r = radius F = finish	Straight reducers K = reduced width F = finish	Offset reducers (left hand) K = reduced width F = finish	Offset reducers (right hand) K = reduced width F = finish
EB 150 300 R F	EX 150 r R F	-	-	-
EB 300 300 R F	EX 300 r R F	ESR 300 K F	ELR 300 K F	ERR 300 K F
EB 450 300 R F	EX 450 r R F	ESR 450 K F	ELR 450 K F	ERR 450 K F
EB 600 300 R F	EX 600 r R F	ESR 600 K F	ELR 600 K F	ERR 600 K F
EB 750 300 R F	EX 750 r R F	ESR 750 K F	ELR 750 K F	ERR 750 K F
EB 900 300 R F	EX 900 r R F	ESR 900 K F	ELR 900 K F	ERR 900 K F

Key : selecting extra heavy duty (Emerald) fittings
 Replace the letters shown in red with your choice from the following options :

- A = Angle (°) : 90, 60, 45 or 30
- B = Branch width (mm) : 150, 300, 450, 600, 750, 900
- F = Finish : G (hot dip galvanised after manufacture), D (deep galvanised), S (stainless steel)
- K = Narrowed width when using a reducer (mm) : 150, 300, 450, 600, 750
- r = Radius (mm) : 300, 600

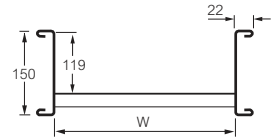

Inside risers. See p. 18

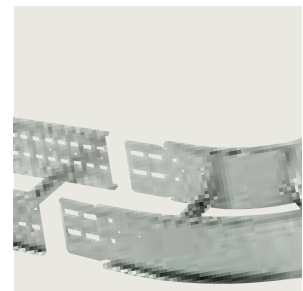

Flat bends. See p. 18

Swifts® medium duty (Topaz) cable ladder

lengths and fittings

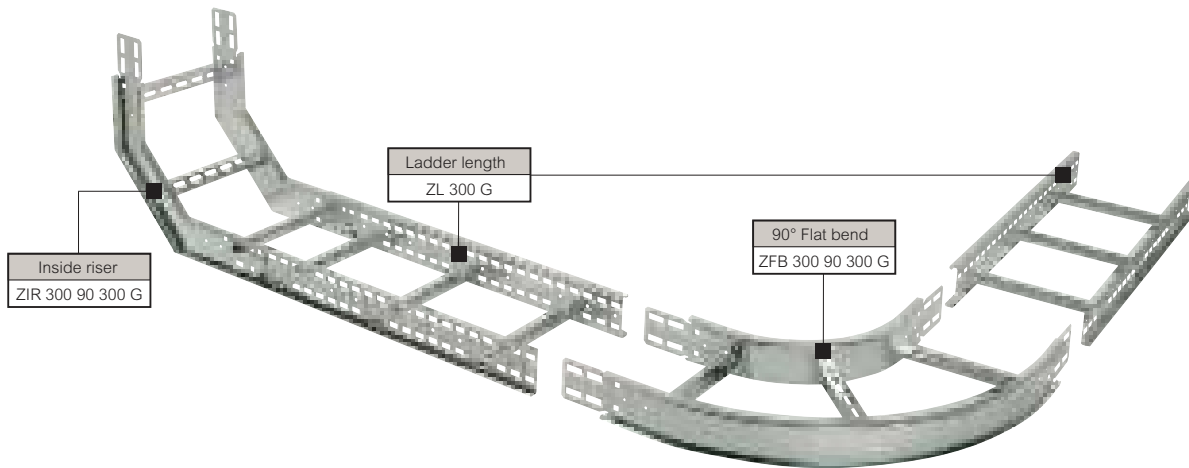
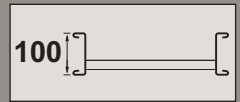

Selection chart (p. 10-11)
Dimensions and technical information : lengths (p. 34) ; coupler sets (p. 38-45) ; fittings (p. 46-73)
Design notes (p. 112)
Loading graphs (p. 34)

When connecting fittings to straight lengths, use fastener sets (see below)
 Rung spacing : 300 mm between centres
 Standard radius for fittings : 300 and 600 mm

Pack	Cat. Nos.	Straight lengths – 3 m
1	ZL 150 F	150 mm width
1	ZL 300 F	300 mm width
1	ZL 450 F	450 mm width
1	ZL 600 F	600 mm width
1	ZL 750 F	750 mm width
1	ZL 900 F	900 mm width

For technical information, see p. 34

Pack	Cat. Nos.	Coupler sets
1	ZC F	Straight length to straight length Supplied in pairs, with fasteners (4 per coupler) Use to couple straight lengths to straight lengths For technical information, see p. 38-39

1	ZFC F	Fitting to fitting Supplied in pairs, with fasteners (4 per coupler) Use to couple fitting to fitting For technical information, see p. 44-45
---	--------------	---

Pack	Cat. Nos.	Fastener sets
50	LFGM10P50	Comprise M10 coach bolt and flange nut
50	LFSM10P50	Hot dip galvanised
		Stainless steel

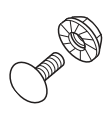

Pack	Cat. Nos.	Fittings
1	ZFB WArF	Flat bends For technical information, see p. 46-49
		90° Flat bend
		60° Flat bend
		45° Flat bend
		30° Flat bend

Pack	Cat. Nos.	Inside risers
1	ZIR WArF	For technical information, see p. 50, 53, 56, 59
		90° Inside riser
		60° Inside riser
		45° Inside riser
		30° Inside riser

Pack	Cat. Nos.	Outside risers
1	ZOR WArF	For technical information, see p. 50, 53, 56, 59
		90° Outside riser
		60° Outside riser
		45° Outside riser
		30° Outside riser

Swifts® medium duty (Topaz) cable ladder

lengths and fittings (continued)

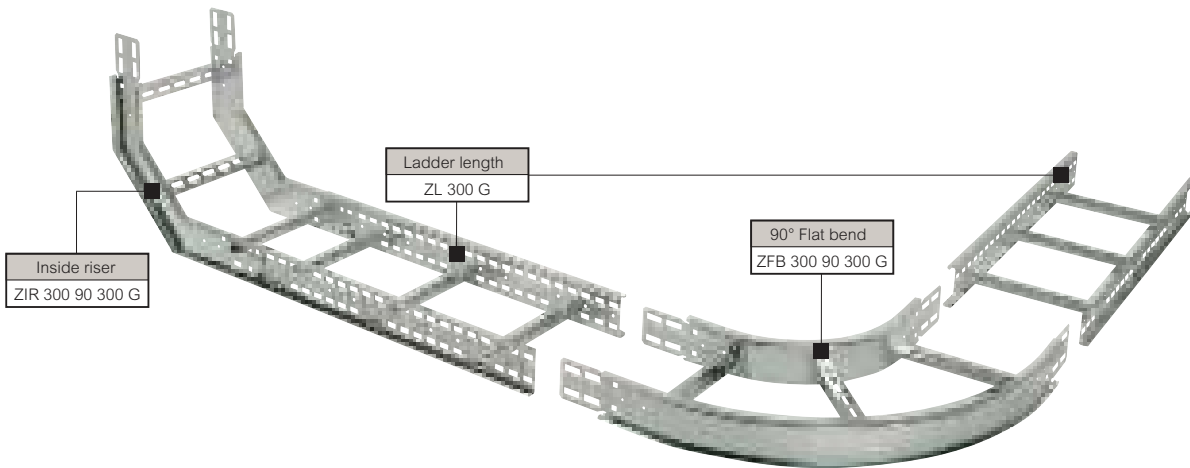
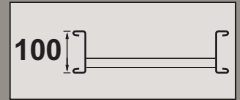

Selection chart (p. 10-11)
 Dimensions and technical information : lengths (p. 34) ; coupler sets (p. 38-45) ; fittings (p. 46-73)
 Design notes (p. 112)
 Loading graphs (p. 34)

When connecting fittings to straight lengths, use fastener sets (see opposite)

Rung spacing : 300 mm between centres
 Standard radius for fittings : 300 and 600 mm

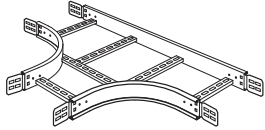
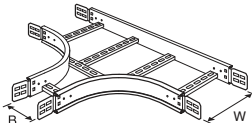
Pack	Cat. Nos.	Fittings (continued)
		Tees and crosspieces For all equal and unequal tees and crosspieces, include R in your ordering code to indicate radius dimension. See unequal tee example below Larger width/radius combinations are supplied in two identical halves with fasteners
1	ZTW ^r R ^F	Equal tees For technical information, see p. 62 
1	ZUTW ^B r ^R F	Unequal tees Example : the ordering code for a hot dip galvanised unequal tee with a 300 main run (W) and a 150 branch (B) with a 600R radius : ZUT 300 150 600R G For technical information, see p. 63-68 

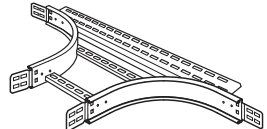
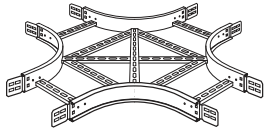
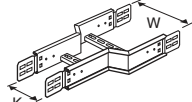
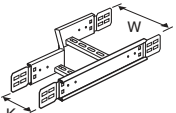
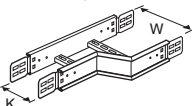
Pack	Cat. Nos.	Fittings (continued)
1	ZB W 300 R F	Branch piece Available in 300 R only For technical information, see p. 69 
1	ZXW ^r R ^F	4 way crosspiece For technical information, see p. 70-71 
1	ZSRW ^K F	Straight reducers For technical information, see p. 72 
1	ZLRW ^K F	Offset reducers – left hand For technical information, see p. 73 
1	ZRRW ^K F	Offset reducers – right hand For technical information, see p. 73 

Standard dimensions and finishes

Key : selecting medium duty (Topaz) fittings. Replace the letters shown in red with your choice from the following options :

- W = Widths (mm) : 150, 300, 450, 600, 750, 900
- A = Angle (°) : 90, 60, 45 or 30
- B = Branch width (mm) : 150, 300, 450, 600, 750, 900
- F = Finish : G (hot dip galvanised after manufacture), D (deep galvanised) S (stainless steel)
- K = Narrowed width when using a reducer (mm) : 150, 300, 450, 600, 750
- r = Radius (mm) : 300, 600

Dimensions and finishes available to special order

Contact us on +44 (0) 845 605 4333

- Radius (r) (mm) : 450, 750 and 900
- Rungs : Type 2 or type 3
- Widths (W) (mm) : 100, 200, 250, 350, 400, 500, 550, 650, 700, 800, 850 and 950
- Angles (°) : Available to customer's specification
- Finish (F) : Pickle and passivation on stainless steel

Swifts® heavy duty (Sapphire) cable ladder

lengths and fittings

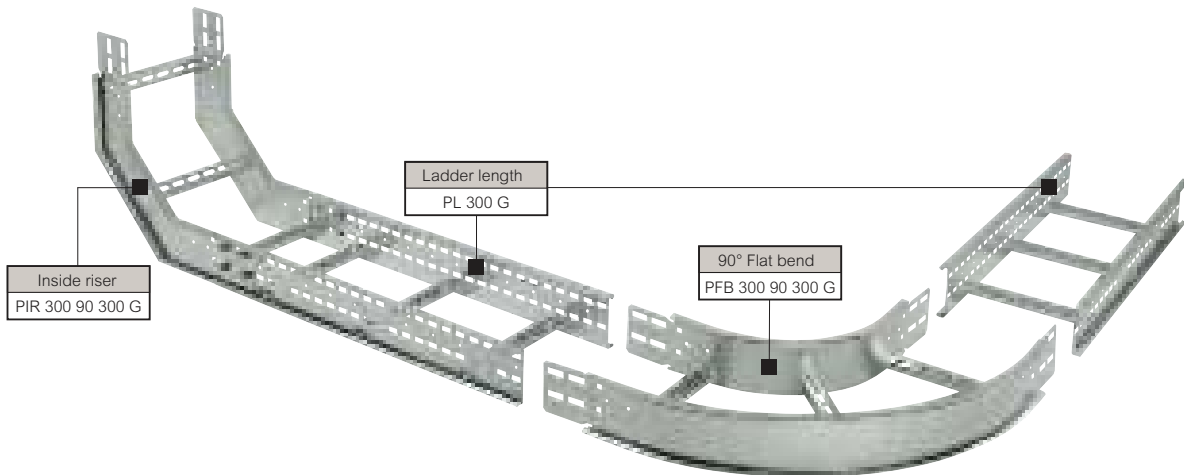
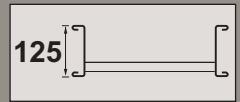

Selection chart (p. 10-11)
 Dimensions and technical information : lengths (p. 35) ; coupler sets (p. 38-45) ; fittings (p. 46-73)
 Design notes (p. 112)
 Loading graphs (p. 34)

When connecting fittings to straight lengths, use fastener sets (see below)

Rung spacing : 300 mm between centres
 Standard radius for fittings : 300 and 600 mm

Pack	Cat. Nos.	Straight lengths – 3 m
1	PL 150 F	150 mm width
1	PL 300 F	300 mm width
1	PL 450 F	450 mm width
1	PL 600 F	600 mm width
1	PL 750 F	750 mm width
1	PL 900 F	900 mm width

6 m lengths available on special request
 For technical information, see p. 35

Pack	Cat. Nos.	Coupler sets
1	PC F	Straight length to straight length Supplied in pairs, with fasteners (8 per coupler) Use to couple straight lengths to straight lengths For technical information, see p. 38-39

Pack	Cat. Nos.	Fitting to fitting
1	PFC F	Supplied in pairs, with fasteners (8 per coupler) Use to couple fitting to fitting For technical information, see p. 44-45

Pack	Cat. Nos.	Fastener sets
50	LFGM10P50	Comprise M10 coach bolt and flange nut
50	LFSM10P50	Hot dip galvanised
		Stainless steel



Pack	Cat. Nos.	Fittings
1	PFB WArF	Flat bends For technical information, see p. 46-49 90° Flat bend 60° Flat bend 45° Flat bend 30° Flat bend
1	PIR WArF	Inside risers For technical information, see p. 51, 54, 57, 60 90° Inside riser 60° Inside riser 45° Inside riser 30° Inside riser
1	POR WArF	Outside risers For technical information, see p. 51, 54, 57, 60 90° Outside riser 60° Outside riser 45° Outside riser 30° Outside riser

Swifts® heavy duty (Sapphire) cable ladder

lengths and fittings (continued)

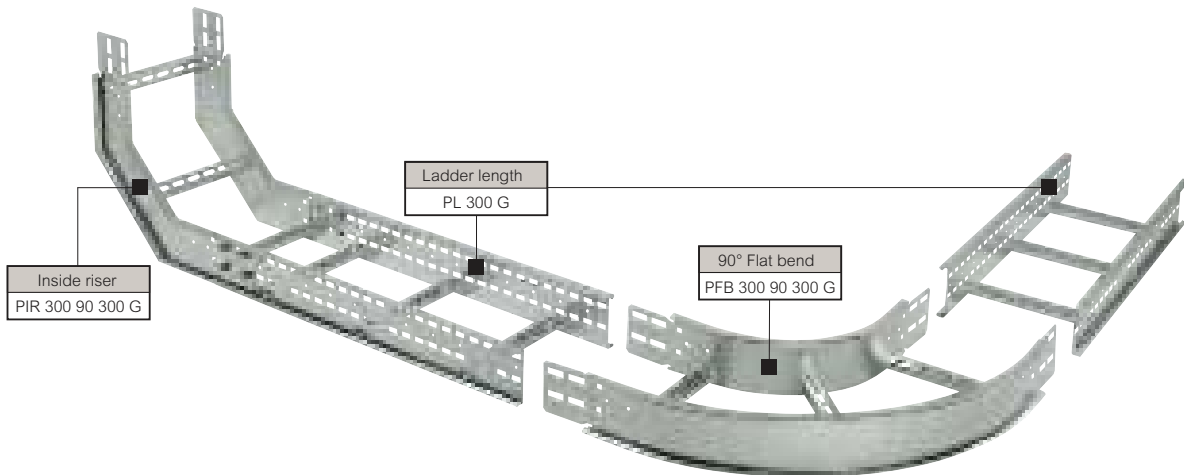
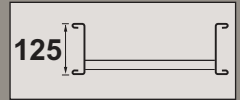

Selection chart (p. 10-11)
 Dimensions and technical information : lengths (p. 35) ; coupler sets (p. 38-45) ; fittings (p. 46-73)
 Design notes (p. 112)
 Loading graphs (p. 34)

When connecting fittings to straight lengths, use fastener sets (see opposite)

Rung spacing : 300 mm between centres
 Standard radius for fittings : 300 and 600 mm

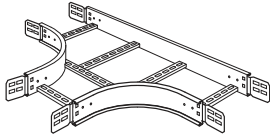
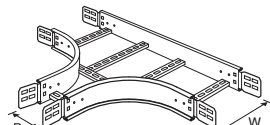
Pack	Cat. Nos.	Fittings (continued)
		Tees and crosspieces For all equal and unequal tees and crosspieces, include R in your ordering code to indicate radius dimension. See unequal tee example below Larger width/radius combinations are supplied in two identical halves with fasteners
1	PTW ^r RF	Equal tees For technical information, see p. 62
		
1	PUTWB ^r RF	Unequal tees Example : the ordering code for a hot dip galvanised unequal tee with a 300 main run (W) and a 150 branch (B) with a 600R radius : PUT 300 150 600R G For technical information, see p. 63-68
		

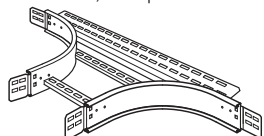
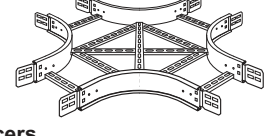
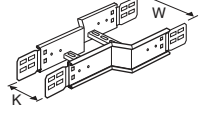
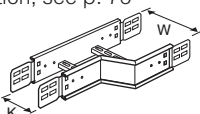
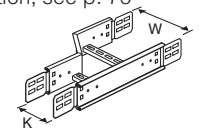
Pack	Cat. Nos.	Fittings (continued)
1	PB W 300 R F	Branch piece. Available in 300 R only For technical information, see p. 69
		
1	PXW ^r RF	4 way crosspieces For technical information, see p. 70-71
		
1	PSRWKF	Straight reducers For technical information, see p. 72
		
1	PLRWKF	Offset reducers – left hand For technical information, see p. 73
		
1	PRRWKF	Offset reducers – right hand For technical information, see p. 73
		

Standard dimensions and finishes

Key : selecting heavy duty (Sapphire) fittings. Replace the letters shown in red with your choice from the following options :

- W = Widths : 150, 300, 450, 600, 750, 900
- A = Angle (°) : 90, 60, 45 or 30
- B = Branch width (mm) : 150, 300, 450, 600, 750, 900
- F = Finish : G (hot dip galvanised after manufacture), D (deep galvanised) S (stainless steel), E (powder coated)
- K = Narrowed width when using a reducer (mm) : 150, 300, 450, 600, 750
- r = Radius (mm) : 300, 600

Dimensions and finishes available to special order

Contact us on +44 (0) 845 605 4333

- Radius (r) (mm) : 450, 750 and 900
- Rungs : Type 2 or type 3
- Widths (W) (mm) : 100, 200, 250, 350, 400, 500, 550, 650, 700, 800, 850 and 950
- Angles (°) : Available to customer's specification
- Finish (F) : Pickle and passivation on stainless steel

Swifts® extra heavy duty (Emerald) cable ladder

lengths and fittings

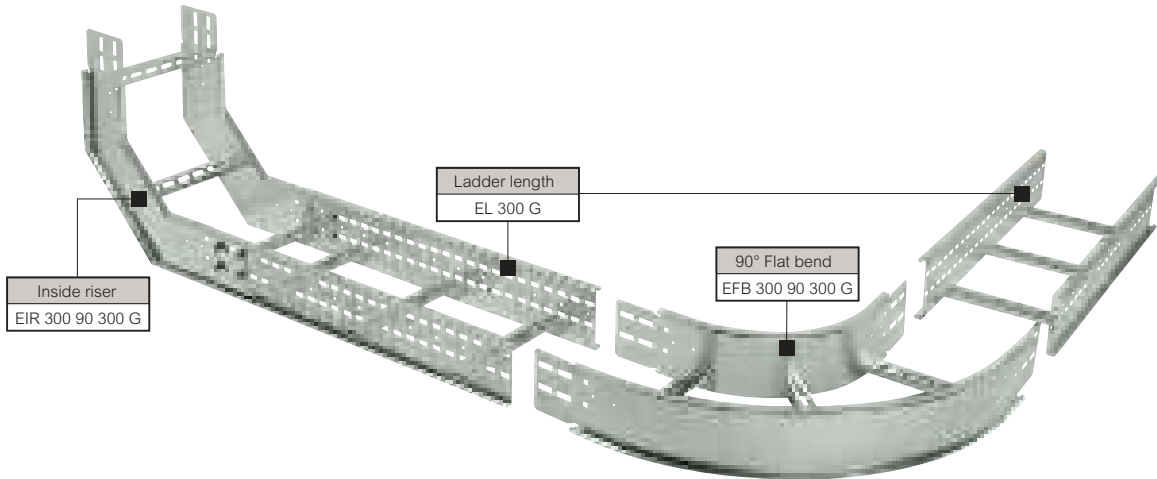
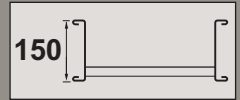

Selection chart (p. 10-11)
 Dimensions and technical information : lengths (p. 36) ; coupler sets (p. 38-45) ; fittings (p. 46-73)
 Design notes (p. 112)
 Loading graphs (p. 34)

When connecting fittings to straight lengths, use fastener sets (see below)

Rung spacing : 300 mm between centres
 Standard radius for fittings : 300 and 600 mm

Pack	Cat. Nos.	Straight lengths – 3 m
1	EL 150 F	150 mm width
1	EL 300 F	300 mm width
1	EL 450 F	450 mm width
1	EL 600 F	600 mm width
1	EL 750 F	750 mm width
1	EL 900 F	900 mm width

6 m lengths available on special request
 For technical information, see p. 36

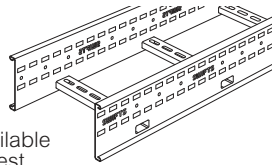

Pack	Cat. Nos.	Coupler sets
1	EC F	Straight length to straight length Supplied in pairs, with fasteners (8 per coupler) Use to couple straight lengths to straight lengths For technical information, see p. 38-39

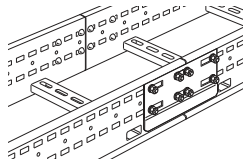

1	EFC F	Fitting to fitting Supplied in pairs, with fasteners (8 per coupler) Use to couple fitting to fitting For technical information, see p. 44-45
---	-------	---

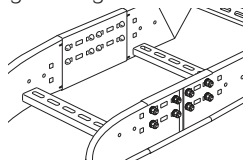

Pack	Cat. Nos.	Fastener sets
50	LFGM10P50	Comprise M10 coach bolt and flange nut
50	LFSM10P50	Hot dip galvanised
		Stainless steel

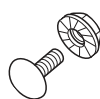

Pack	Cat. Nos.
1	EFB WArF
1	EIR WArF
1	EOR WArF

Fittings

Flat bends

For technical information, see p. 46-49

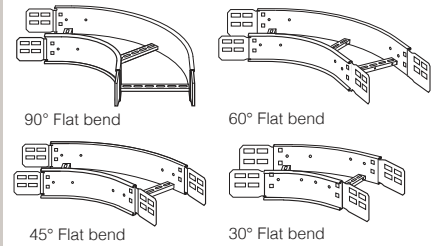

Inside risers

For technical information, see p. 52, 55, 58, 61

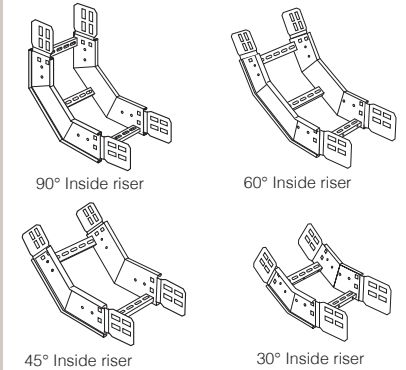

Outside risers

For technical information, see p. 52, 55, 58, 61

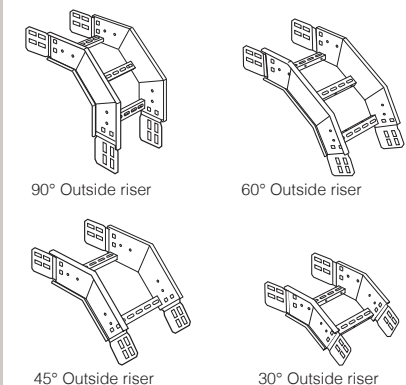

Swifts® extra heavy duty (Emerald) cable ladder

lengths and fittings (continued)

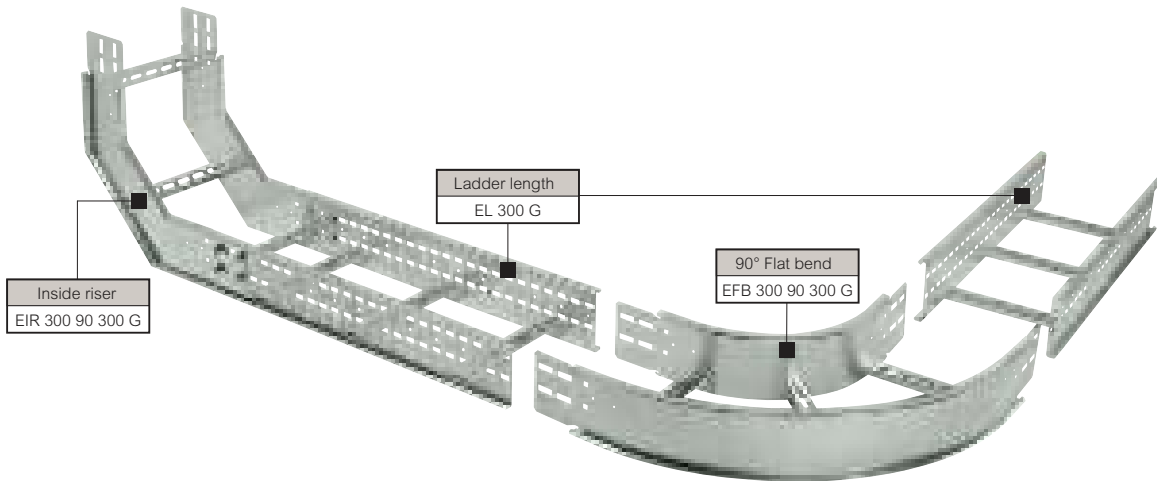
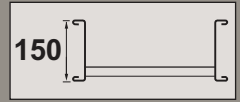

Selection chart (p. 10-11)
 Dimensions and technical information : lengths (p. 36) ; coupler sets (p. 38-45) ; fittings (p. 46-73)
 Design notes (p. 112)
 Loading graphs (p. 34)

When connecting fittings to straight lengths, use fastener sets (see opposite)

Rung spacing : 300 mm between centres
 Standard radius for fittings : 300 and 600 mm

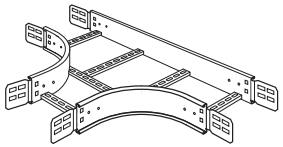
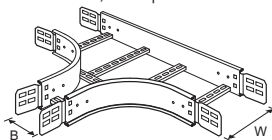
Pack	Cat. Nos.	Fittings (continued)
		Tees and crosspieces For all equal and unequal tees and crosspieces, include R in your ordering code to indicate radius dimension. See unequal tee example below. Larger width/radius combinations are supplied in two identical halves with fasteners
1	ETW ^r RF	Equal tees For technical information, see p. 62
		
1	EUTW ^B rRF	Unequal tees Example : the ordering code for a hot dip galvanised unequal tee with a 300 main run (W) and a 150 branch (B) with a 600R radius : PUT 300 150 600R G For technical information, see p. 63-68
		

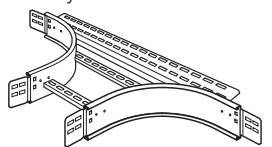
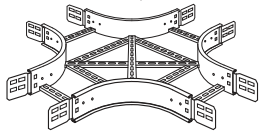
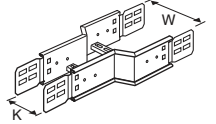
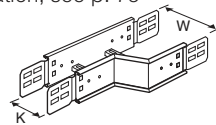
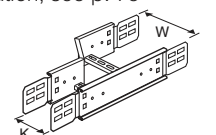
Pack	Cat. Nos.	Fittings (continued)
1	EB W 300 R F	Branch piece For technical information, see p. 69 Available in 300 R only
		
1	EXW ^r RF	4 way crosspieces For technical information, see p. 70-71
		
1	ESRWKF	Straight reducers For technical information, see p. 72
		
1	ELRWKF	Offset reducers – left hand For technical information, see p. 73
		
1	ERRWKF	Offset reducers – right hand For technical information, see p. 73
		

Standard dimensions and finishes

Key : selecting extra heavy duty (Emerald) fittings. Replace the letters shown in red with your choice from the following options :

W = Widths (mm) : 150, 300, 450, 600, 750, 900

A = Angle (°) : 90, 60, 45 or 30

B = Branch width (mm) : 150, 300, 450, 600, 750, 900

F = Finish : G (hot dip galvanised after manufacture),
 D (deep galvanised) S (stainless steel)

K = Narrowed width when using a reducer (mm) :

150, 300, 450, 600, 750 r = Radius (mm) : 300, 600

Dimensions and finishes available to special order

Contact us on +44 (0) 845 605 4333

Radius (r) (mm) : 450, 750 and 900

Rungs : Type 2 or type 3

Widths (W) (mm) : 200, 250, 350, 400, 500, 550, 650, 700, 800, 850 and 950

Angles (°) : Available to customer's specification

Finish (F) : Pickle and passivation on stainless steel

Swifts® cable ladder supports

medium duty (Topaz), heavy duty (Sapphire) and extra heavy duty (Emerald)

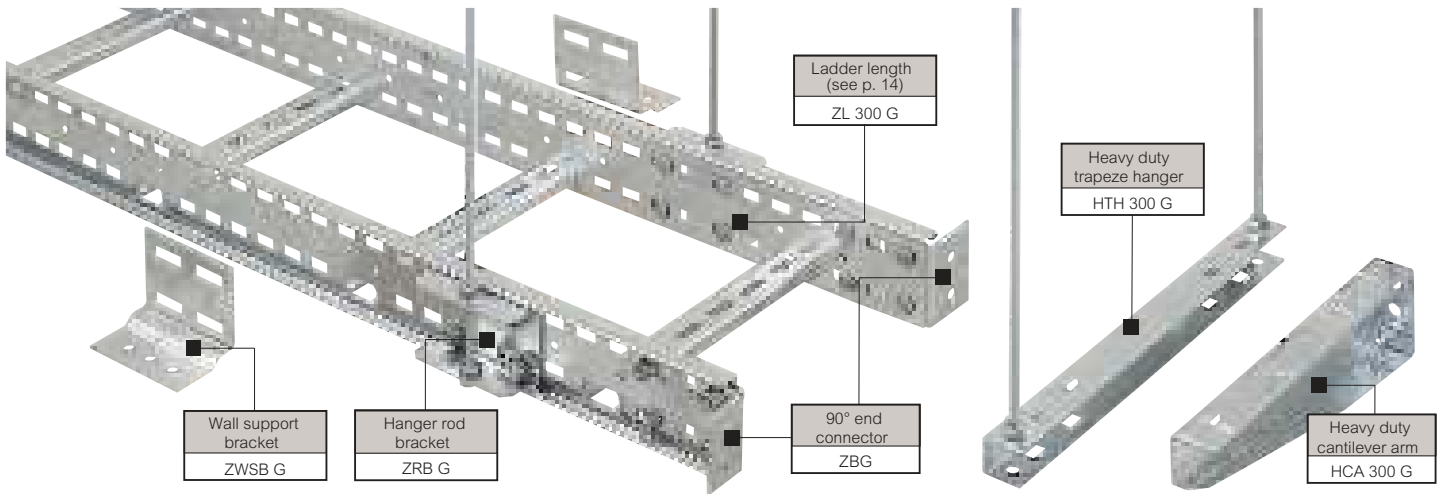
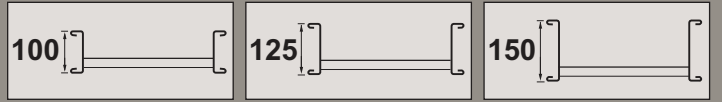

Dimensions and technical information (p. 74-78)

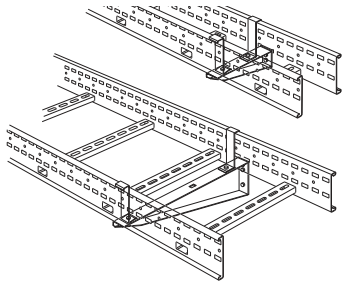
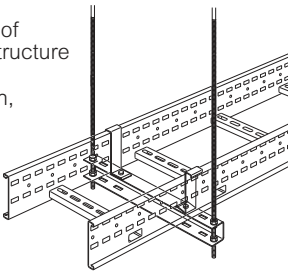
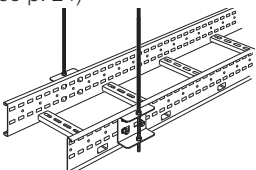
Pack	Cat. Nos.	Supports
		For use with medium duty (Topaz), heavy duty (Sapphire) and extra heavy duty (Emerald) ladder
1	HCA WF	<p>Heavy duty cantilever arms</p> <p>Supplied singly without fasteners Use to fit horizontal runs of ladder to flat surfaces and Swiftrack channel All arms have slots in top flanges to accept ladder hold down brackets For technical information, see p. 74</p> 
1	HTH WF	<p>Heavy duty trapeze hangers</p> <p>Supplied singly without fasteners Support horizontal runs of ladder from overhead structure Use M12 threaded rods For technical information, see p. 75</p> 
1	ZRB F	<p>Hanger rod brackets</p> <p>When hanger rod brackets are fitted to ladder, covers can not be used Supplied in pairs with bracket to ladder fasteners Support horizontal runs of ladder from overhead structure Use M10 threaded rods, (see p. 24) For technical information, see p. 76</p> 
1	PRB F	
1	ERB F	

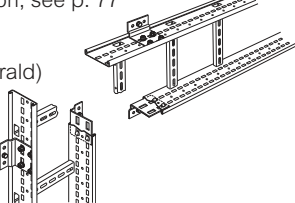
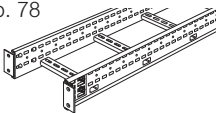
Pack	Cat. Nos.	Supports (continued)
		<p>Wall support brackets</p> <p>Supplied in pairs with bracket to ladder fasteners Fit horizontal or vertical runs of ladder to vertical surfaces and Swiftrack channel For technical information, see p. 77</p> 
1	ZWSB F	<p>Medium duty (Topaz) Heavy duty (Sapphire) Extra heavy duty (Emerald)</p>
1	PWSB F	
1	EWSB F	
1	ZB F	<p>90° end connectors</p> <p>Supplied in pairs with bracket to ladder fastener Fits ends of ladder to vertical surfaces For technical information, see p. 78</p> 
1	PB F	
1	EB F	

Key : selecting medium duty (Topaz), heavy duty (Sapphire) and extra heavy duty (Emerald) supports. Replace the letters shown in red with your choice from the following options :

W = Widths : 150, 300, 450, 600, 750, 900
F = Finish : **G** (hot dip galvanised after manufacture),
D (deep galvanised) **S** (stainless steel), **E** (powder coated)

Swifts® cable ladder ancillary items

medium duty (Topaz), heavy duty (Sapphire) and extra heavy duty (Emerald)

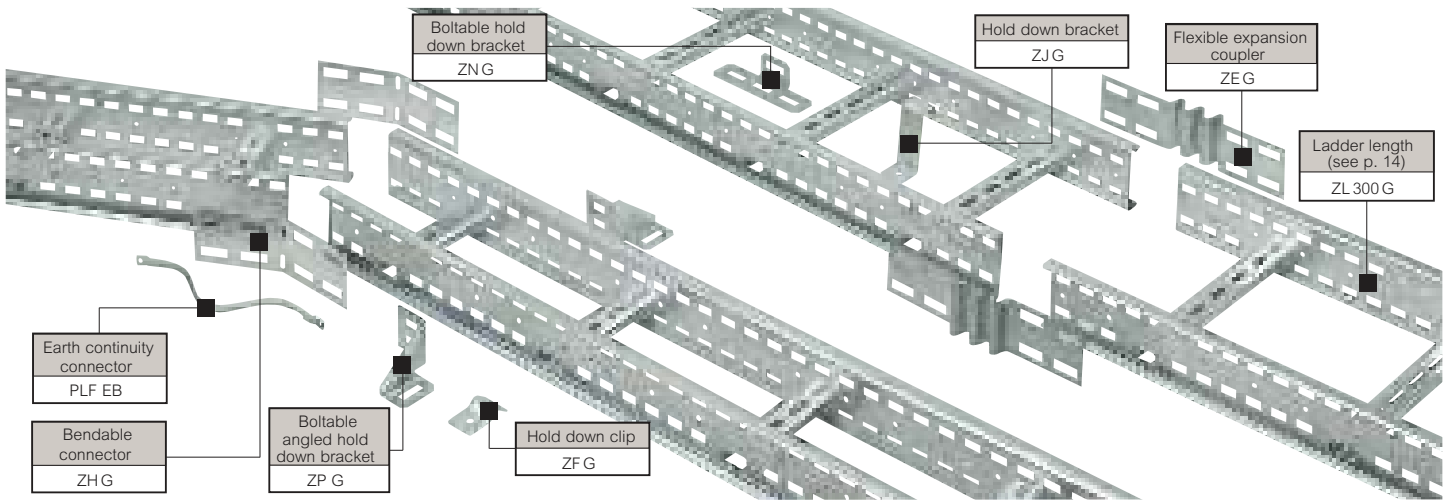
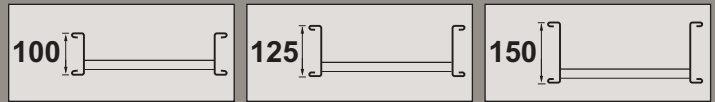

Dimensions and technical information (p. 79-83)
 Dimensions and technical information coupler sets (p. 38-45)

Pack	Cat. Nos.	Ancillary items
		Bendable connectors
		Supplied in pairs with fasteners For fabricating fittings on site to make up bends, reducers and compensate for misalignment of straight lengths For technical information, see p. 41
1	ZH F	Medium duty (Topaz)
1	PH F	Heavy duty (Sapphire)
1	EH F	Extra heavy duty (Emerald)
		Flexible expansion couplers
		Supplied in pairs with fasteners Provide a semi-flexible joint to compensate for relative movement when spanning separate structures or changes in ladder lengths due to temperature variation For technical information, see p. 40
1	ZE F	Medium duty (Topaz)
1	PE F	Heavy duty (Sapphire)
1	EE F	Extra heavy duty (Emerald)
		Earth continuity connectors
10	PLFEB	Medium duty (Topaz), heavy duty (Sapphire), extra heavy duty (Emerald) M6 brass fasteners included in pack Copper braid and copper lugs both in electroplated finish Conductor area : 16 mm ² For technical information, see p. 79

Pack	Cat. Nos.	Ancillary items (continued)
		Hold down clip
		Supplied singly without fasteners Fits ladder to flat surfaces, Swiftrack channel or heavy duty trapeze hangers which have slots in the top flange to accept fasteners For insulated version, add IN after Cat. No., eg. ZFIN F. (Note : note available in D finish) For technical information, see p. 80
1	ZF F	Medium duty (Topaz)
1	PF F	Heavy duty (Sapphire)
1	EF F	Extra heavy duty (Emerald)
		Hold down bracket
		Supplied singly without fasteners Fits ladder to flat surfaces, Swiftrack channel, cantilever arms or heavy duty trapeze hangers which have slots in the top flange to accept fasteners For insulated version, add IN after Cat. No., eg. ZJIN F. (Note : note available in D finish) For technical information, see p. 81
1	ZJ F	Medium duty (Topaz)
1	PJ F	Heavy duty (Sapphire)
1	EJ F	Extra heavy duty (Emerald)
		Boltable hold down bracket
		Supplied singly with bracket to ladder fastener Fits ladder to Swiftrack channel in fabricated steel support structure For technical information, see p. 82
1	ZN F	Medium duty (Topaz)
1	PN F	Heavy duty (Sapphire)
1	EN F	Extra heavy duty (Emerald)
		Boltable angled hold down brackets
		Supplied in handed pairs with bracket to ladder fastener Fits ladder to heavy duty cantilever arms and trapeze hangers which have slots in the side flange to accept fasteners For technical information, see p. 83
1	ZPF	Medium duty (Topaz)
1	PPF	Heavy duty (Sapphire)
1	EPF	Extra heavy duty (Emerald)

Key : selecting medium duty (Topaz), heavy duty (Sapphire) and extra heavy duty (Emerald) supports. Replace the letters shown in **red** with your choice from the following options :

W = Widths : 150, 300, 450, 600, 750, 900
F = Finish : **G** (hot dip galvanised after manufacture), **D** (deep galvanised) **S** (stainless steel), **E** (powder coated)

Swifts® cable ladder ancillary items (continued)

Topaz, Sapphire and Emerald

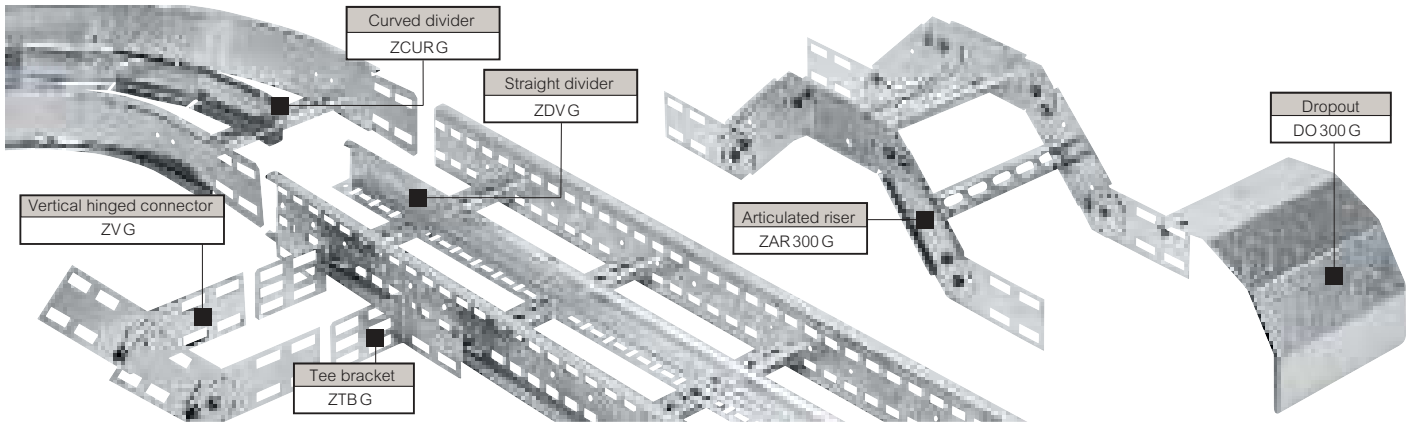
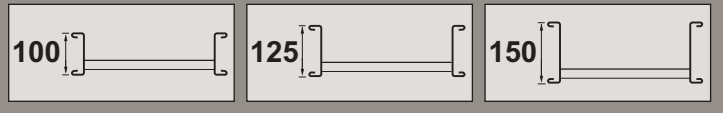

Dimensions and technical information (p. 84-94)

Pack	Cat. Nos.	Ancillary items (continued)
		Straight dividers – 3-0 m
		Supplied with fasteners For technical information, see p. 84
1	ZDV F	Medium duty (Topaz)
1	PDV F	Heavy duty (Sapphire)
1	EDV F	Extra heavy duty (Emerald)
		Curved dividers – 1-0 m
		Supplied with fasteners Drill on site to suit rung position For technical information, see p. 84
1	ZCUR F	Medium duty (Topaz)
1	PCUR F	Heavy duty (Sapphire)
1	ECUR F	Extra heavy duty (Emerald)
		Vertical hinged connectors
		Supplied in sets comprising four plates and fasteners Use with straight lengths to form risers or solve minor misalignment problems on site When used with tee bracket, vertical hinged connectors can offset tee branch For technical information, see p. 42
1	ZV F	Medium duty (Topaz)
1	PV F	Heavy duty (Sapphire)
1	EV F	Extra heavy duty (Emerald)
		Articulated risers
		Set comprises three ladder sections and the necessary vertical hinged connectors with fasteners Use to form risers or solve most misalignment problems on site For technical information, see p. 85-86
1	ZAR WF	Medium duty (Topaz)
1	PAR WF	Heavy duty (Sapphire)
1	EAR WF	Extra heavy duty (Emerald)

Pack	Cat. Nos.	Ancillary items (continued)
		Dropout plate
		Supplied with fasteners Use to provide local support for cables as they exit a cable ladder run between rungs For technical information, see p. 87
1	DO WF	All ladder types
		Rail-to-rail dropout brackets
		Supplied in pairs with fasteners Use to attach a vertical run of ladder or tray beneath a horizontal main ladder run For technical information, see p. 88
1	M F	For ladder to ladder connection
		or
		Tray to ladder connection
		Tee brackets
		Supplied in pairs with fasteners Use to create a branch of a straight ladder run For technical information, see p. 89
1	ZTB F	Medium duty (Topaz)
1	PTB F	Heavy duty (Sapphire)
1	ETB F	Extra heavy duty (Emerald)
		Stop ends
		Supplied singly with fasteners. Use to terminate a ladder run, or to fix the end of a run to a vertical surface For technical information, see p. 94
1	ZSW F	Medium duty (Topaz)
1	PSW F	Heavy duty (Sapphire)
1	ESW F	Extra heavy duty (Emerald)

Key : selecting ancillary items. Replace the letters shown in red with your choice from the following options :

W = Widths (mm) : 150, 300, 450, 600, 750, 900
 F = Finish : G (hot dip galvanised after manufacture),
 D (deep galvanised) S (stainless steel), E (powder coated)

Swifts® cable ladder ancillary items (continued) and covers

Topaz, Sapphire and Emerald

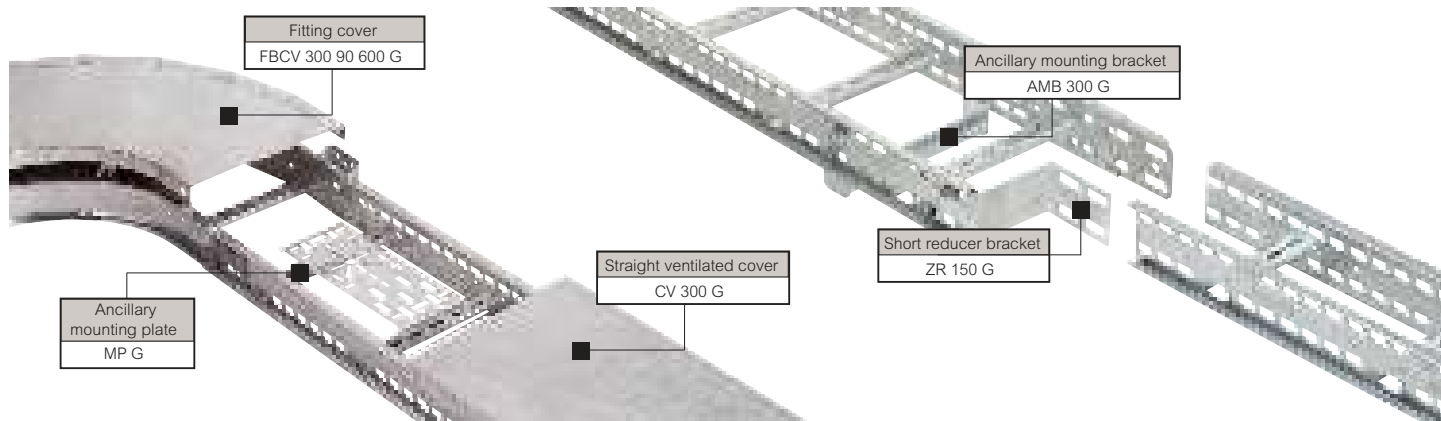
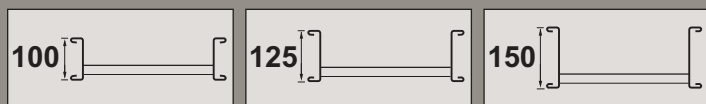

Dimensions and technical information (p. 90-98)

Pack	Cat. Nos.	Ancillary items (continued)	Pack	Cat. Nos.	Covers
1	ZR YF PR YF ER YF	Short reducer brackets Supplied singly with fasteners Use to form a reducer on site Straight reducer – use in pairs Offset reducer – use singly with straight coupler $Y = W - K$ (Offset reducer) $Y = \frac{W - K}{2}$ (Straight reducer) W = main ladder mm K = reduced ladder mm To calculate (Y) for straight reducers and offset reducers (see p. 90) For technical information, see p. 90	1	CV W F	Supplied with clips and fasteners Covers for both closed and ventilated installations are common (except when using inside and outside risers, see below) 600 mm wide and above are overlap jointed for rigidity For technical information, see p. 95-98 Straight covers – 3·0 m Available in 150-900 mm widths Example : To cover a 300 mm wide Z, P or E ladder length with a straight hot dip galvanised cover, ordering code for cover = CV 300 G
1	AMB W F	Ancillary mounting bracket Supplied singly with bracket to ladder fasteners For technical information, see p. 91 All ladder types 	1	–	Covers for fittings (except risers) To order a cover for a fitting, (except risers) remove first letter of fitting product code (Z, P or E) and add CV before your chosen dimensions Example : Product code = PFB 300 90 600 G Cover code = FB CV 300 90 600 G
1	MP F	Ancillary mounting plate Supplied singly with bracket to ladder fasteners For technical information, see p. 92 All ladder types For rung mounting or Side rail mounting 	1	ZIRC WArF PIRC WArF EIRC WArF	Inside riser closed covers Medium duty (Topaz) Heavy duty (Sapphire) Extra heavy duty (Emerald)
1	CSB F	Cable support bracket For technical information, see p. 93 Supplied singly with fasteners Cable ties not included 	1	ZIRV WArF PIRV WArF EIRV WArF	Inside riser ventilated covers Medium duty (Topaz) Heavy duty (Sapphire) Extra heavy duty (Emerald)
			1	ZORC WArF PORC WArF EORC WArF	Outside riser closed covers Medium duty (Topaz) Heavy duty (Sapphire) Extra heavy duty (Emerald)
			1	ZORV WArF PORV WArF EORV WArF	Outside riser ventilated covers Medium duty (Topaz) Heavy duty (Sapphire) Extra heavy duty (Emerald)

Key : selecting for ancillary items and covers. Replace the letters shown in red with your choice from the following options :

W = Widths : 150, 300, 450, 600, 750, 900
 Y = Ladder width reduction A = Angle (°) : 90, 60, 45 or 30
 F = Finish : G (hot dip galvanised after manufacture), D (deep galvanised) S (stainless steel), E (powder coated)
 K = Narrowed width when using a reducer (mm) : 150, 300, 450, 600, 750
 r = Radius (mm) : 300, 600

Swifts® cable ladder fasteners

medium duty (Topaz), heavy duty (Sapphire) and extra heavy duty (Emerald)

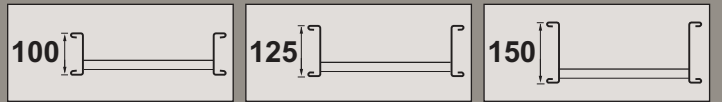

Pack	Cat. Nos.	Fastener sets	
50 50	LFGM10P50 LFSM10P50	Comprise M10 coach bolt and flange nut Hot dip galvanised Stainless steel	
Fasteners			
Hexagon head setscrews			
Electroplated zinc			
200	SS0616	M6 x 16	
200	SS0620	M6 x 20	
200	SS0625	M6 x 25	
200	SS0630	M6 x 30	
200	SS1016	M10 x 16	
200	SS1020	M10 x 20	
200	SS1025	M10 x 25	
200	SS1030	M10 x 30	
100	SS1035	M10 x 35	
100	SS1040	M10 x 40	
100	SS1045	M10 x 45	
100	SS1050	M10 x 50	
100	SS1060	M10 x 60	
100	SS1220	M12 x 20	
100	SS1225	M12 x 25	
100	SS1230	M12 x 30	
100	SS1235	M12 x 35	
100	SS1240	M12 x 40	
100	SS1250	M12 x 50	
Hot dip galvanised			
200	SSG0616	M6 x 16	
200	SSG0620	M6 x 20	
200	SSG0625	M6 x 25	
200	SSG0630	M6 x 30	
Flat washers			
Electroplated zinc			
500	FW06	M6	
500	FW08	M8	
500	FW10	M10	
500	FW12	M12	
Shakeproof washers			
Electroplated zinc			
400	SW06	M6	
400	SW08	M8	
400	SW10	M10	
400	SW12	M12	

Pack	Cat. Nos.	Fasteners (continued)	
Hexagon nuts			
Electroplated zinc			
500	HN06	M6	
500	HN08	M8	
500	HN10	M10	
500	HN12	M12	
Roofing nuts and bolts			
Electroplated zinc			
200	RB0612	M6 x 12	
200	RB0616	M6 x 16	
200	RB0620	M6 x 20	
200	RB0625	M6 x 25	
100	RB0630	M6 x 30	
100	RB0640	M6 x 40	
100	RB0650	M6 x 50	
Hot dip galvanised			
100	RBG0612	M6 x 12	
100	RBG0616	M6 x 16	
Stainless steel			
100	RB0612S	M6 x 12	
100	RB0616S	M6 x 16	
100	RB0620S	M6 x 20	
Threaded rods			
Electroplated zinc			
1	TR06	M6 x 3 m	
1	TR08	M8 x 3 m	
1	TR10	M10 x 3 m	
1	TR12	M12 x 3 m	
Threaded rod connectors			
Electroplated zinc			
1	RC06	M6	
1	RC08	M8	
1	RC10	M10	
1	RC12	M12	

Swiftrack channel support system

channels and channel nuts



Typical applications (p. 134-135)
Dimensions and technical information (p. 99-101)
Design notes (p. 112)

Channel and brackets are manufactured to BS 6946 – specifications for metal channel cable support systems for electrical installations and calculations for loading are in accordance with BS 5950 : Part 5 1998 structural use of steelwork in buildings, code of practice for cold formed thin gauge sections

Pack	Cat. Nos.	Single channels - plain
		The standard finish for channel is pre-galvanised mild steel to BS EN 10346. For other finishes add the appropriate suffix. G = hot dip galvanised after manufacture to BS EN ISO 1461 S = stainless steel to BS EN 10088 2 grade 1-4404 (equivalent to S316L31) Channels SC210 and SC410 are not available in S finish. Examples : SC200 3M G for hot dip galvanised SC400 3M S for stainless steel For technical information, see p. 99
1	SC200 3M	Standard channel 41 x 21 mm, 3 m length
1	SC200 6M	41 x 21 mm, 6 m length
1	SC400 3M	41 x 41 mm, 3 m length
1	SC400 6M	41 x 41 mm, 6 m length
1	SC210 3M	Light gauge channel 41 x 21 mm, 3 m length
1	SC410 3M	41 x 41 mm, 3 m length

Pack	Cat. Nos.	Back-to-back channel
1	SC401 3M	For technical information see p. 100 41 x 83 mm, 3 m length
1	SC401 6M	41 x 83 mm, 6 m length

Pack	Cat. Nos.	Single channels - slotted
		For technical information, see p. 99
1	SC203 3M	Standard channel 41 x 21 mm, 3 m length
1	SC203 6M	41 x 21 mm, 6 m length
1	SC403 3M	41 x 41 mm, 3 m length
1	SC403 6M	41 x 41 mm, 6 m length
1	SC213 3M	Light gauge channel 41 x 21 mm, 3 m length
1	SC413 3M	41 x 41 mm, 3 m length

Pack	Cat. Nos.	Channel nuts
		For use with all channel M12 channel nuts should always be used for maximum load conditions The standard finish for all nuts is zinc plated to BS 3382 : Part 2 For stainless steel, add the suffix S Example : PN101S For hot dip galvanised, add the suffix G Example : PN101G Fasteners : Use hexagon head setscrews (see p. 29) For technical information, see p. 101

Pack	Cat. Nos.	Long springs
		For use with 41 mm deep channel
100	PN061	M6
100	PN081	M8
100	PN101	M10
100	PN121	M12

Pack	Cat. Nos.	Short springs
		For use with 21 mm deep channel
100	PN062	M6
100	PN082	M8
100	PN102	M10
100	PN122	M12

Pack	Cat. Nos.	No springs
		For use on all channel depths
100	PN060	M6
100	PN080	M8
100	PN100	M10
100	PN120	M12

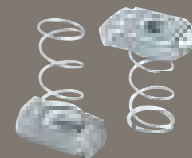

Other fasteners and finishes available to special order

Contact us on +44 (0) 845 605 4333

Swiftrack channel support system

cantilever arms

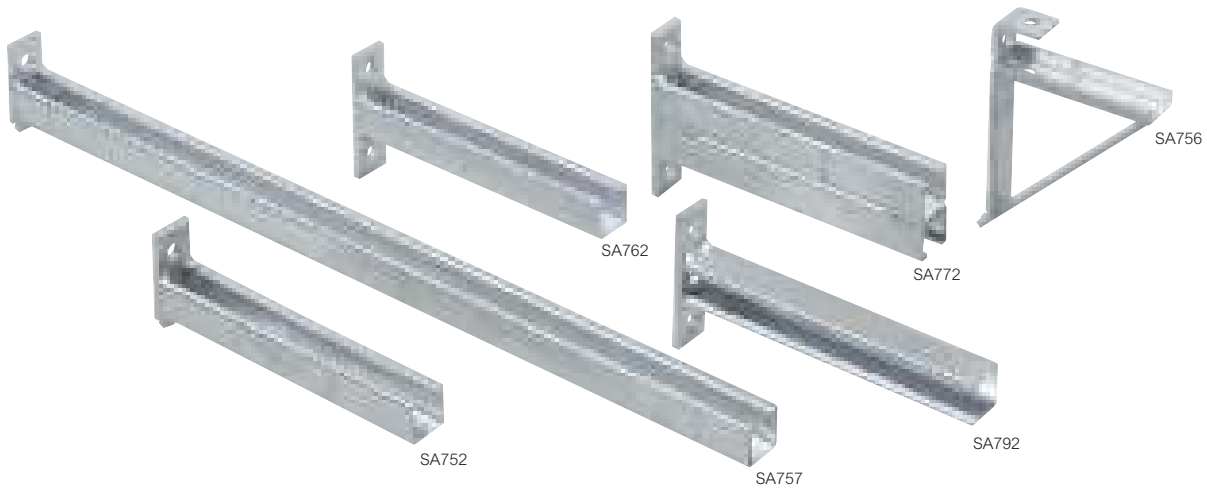

Dimensions and technical information (p. 102-103)

Pack	Cat. Nos.	Cantilever arms
		In addition to the cantilever arms listed, there are many other specialist support brackets for use with cable ladder. These are detailed in the relevant sections in this catalogue.
		Cantilever arms Requires only one bolt for quick fixing and is used with open face at the top. For technical information, see p. 102.
1	SA750	150 mm
1	SA751	225 mm
1	SA752	300 mm
1	SA753	450 mm
1	SA754	600 mm
1	SA755	750 mm
1	SA757	900 mm
		Cantilever arms, universal Two bolt fixing. Can be used with open face at the top or bottom. For technical information, see p. 102.
1	SA760	150 mm
1	SA761	225 mm
1	SA762	300 mm
1	SA763	450 mm
1	SA764	600 mm
1	SA765	750 mm
1	SA766	900 mm
		Cantilever arms, side Two bolt fixing. Can be used with open face on the left or right. For technical information, see p. 102.
1	SA790	150 mm
1	SA791	225 mm
1	SA792	300 mm
1	SA793	450 mm
1	SA794	600 mm
1	SA795	750 mm
1	SA796	900 mm

Pack	Cat. Nos.	Cantilever arms (continued)
		Cantilever arms, double channel Two bolt fixing with extra support. Open face top and bottom. For technical information, see p. 102.
1	SA770	150 mm
1	SA771	225 mm
1	SA772	300 mm
1	SA773	450 mm
1	SA774	600 mm
1	SA775	750 mm
1	SA776	900 mm
1	SA756	Cantilever arm bracket Used to provide extra support to a horizontal run of channel. For technical information see p. 103.

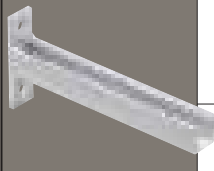

Non-standard cantilever arms available to special order

Contact us on +44 (0) 845 605 4333

Swiftrack channel support system

framework brackets

90° brackets

Cat. No. SB500	Cat. No. SB501	Cat. No. SB502	Cat. No. SB503	Cat. No. SB504
Cat. No. SB505	Cat. No. SB550	Cat. No. SB551	Cat. No. SB552	Cat. No. SB556

Square and splice plates

<p>Square plates</p> <p>Cat. Nos. SB506 06 SB506 08 SB506 10 SB506 12</p> <p>Hole size M6 M8 M10 M12</p>	<p>Splice plate⁽¹⁾</p> <p>Cat. No. SB507</p>	<p>Splice plate⁽¹⁾</p> <p>Cat. No. SB508</p>	<p>Splice plate⁽¹⁾</p> <p>Cat. No. SB509</p>	<p>Splice plate⁽¹⁾</p> <p>Cat. No. SB510</p>
---	--	--	--	--

Z brackets

U brackets

Cat. No. SB511	Cat. No. SB513	Cat. No. SB514	Cat. No. SB515

Angle brackets

<p>Obtuse angle brackets</p> <p>Cat. Nos. Angle SB520 15° SB524 45° SB526 60° SB528 75°</p>	<p>Acute angle brackets</p> <p>Cat. Nos. Angle SB532 45° SB534 60° SB536 75°</p>
---	--

T plates and brackets

<p>T plate</p> <p>Cat. No. SB554</p>	<p>T plate</p> <p>Cat. No. SB555</p>	<p>T bracket</p> <p>Cat. No. SB603</p>	<p>Cross plate</p> <p>Cat. No. SB603+</p>	<p>90° T bracket</p> <p>Cat. No. SB606⁽³⁾</p>	<p>45° T bracket</p> <p>Cat. No. SB607⁽³⁾</p>
---	---	---	--	---	---

(1) Splice plates – holes spaced at 45 mm centres

(2) Hole on one side of bracket only

(3) SB606 and SB607 are not available in S (stainless steel) finish

→ For technical information : see p. 104-107

Swiftrack channel support system

framework brackets (continued)

Joining brackets and channels			Base plates		
Channel joining bracket Cat. No. SB518	Joining channel for SC200 channel Cat. No. SB650	Joining channel for SC400 channel Cat. No. SB651	Single channel base plate Cat. No. SB704	Double channel base plate Cat. No. SB705	
L brackets			Wing brackets		
L bracket Cat. No. SB600	Right hand L corner bracket Cat. No. SB601 ⁽²⁾	Left hand L corner bracket Cat. No. SB602 ⁽²⁾	2 lug wing bracket Cat. No. SB700	3 lug wing bracket Cat. No. SB701	Angled wing bracket Cat. No. SB707 ⁽²⁾
Gusseted brackets			Shelf brackets		
Single channel gusseted bracket Cat. No. SB702	Double channel gusseted bracket Cat. No. SB706			Shelf bracket Cat. No. SB703	
Beam, window beam and toe beam clamps					
Beam clamp⁽³⁾ Cat. No. SC850	Beam clamp⁽³⁾ Cat. No. SC851	Window beam clamp⁽³⁾ Cat. No. SC852/21	Window beam clamp⁽³⁾ Cat. No. SC852/41	Beam clamp⁽³⁾ Cat. No. SC852/82	
Beam clamp⁽³⁾ Cat. No. SC853	Beam clamp⁽³⁾ Cat. No. SC854	Toe beam clamp⁽³⁾ Cat. No. SC856 ⁽⁴⁾	Beam clamp⁽³⁾ Cat. No. ZC1 ⁽⁵⁾	Beam clamp⁽³⁾ Cat. No. FL2 ⁽⁵⁾	Beam clamp⁽³⁾ Cat. No. SC855
Pipe clamps ⁽⁶⁾			Channel accessories		
 Cat. Nos. SP960 10-14 SP964 17-22 SP965 22-26 SP968 25-35 SP969 32-42 SP972 42-59 SP973 54-65	 Cat. Nos. SP975 62-71 SP976 73-83		Channel end caps⁽⁷⁾ Cat. Nos. SC950B SC950W	Channel end caps⁽⁷⁾ Cat. Nos. SC951B SC951W	Closure strips 3000 Cat. Nos. SC952 SC953

(1) Indicates inside dimensions (2) SB601, SB602 and SB707 are not available in S (stainless steel) finish
 (3) Beam clamps are supplied with nuts, bolts, cone point screws and U bolts where shown (4) Requires 2 setscrews and channel nuts for fixing (not included)
 (5) Stainless steel finish is not available (6) All pipe clamps are available in pre-galvanised and stainless steel finishes
 (7) For SC400, SC401 and SC403 channels (8) For SC200, SC201 and SC203 channels

Swiftrack channel support systems

standard fixings and fasteners

Hexagon head setscrews			Cone point screws			Hexagon nuts			Electroplated roofing nuts and bolts			Hot dip galvanised roofing nuts and bolts		
Pack	Cat. Nos.	Size	Pack	Cat. Nos.	Size	Pack	Cat. Nos.	Size	Pack	Cat. Nos.	Size	Pack	Cat. Nos.	Size
Hexagon head setscrews						Cone point screws								
ELECTROPLATED ZINC						ELECTROPLATED ZINC								
200	SS0616	M6 x 16	100	CP1035	M10 x 35									
200	SS0620	M6 x 20	STAINLESS STEEL											
200	SS0625	M6 x 25	100	CP1035 S	M10 x 35									
200	SS0630	M6 x 30	Hexagon nuts											
200	SS0820	M8 x 20	ELECTROPLATED ZINC											
200	SS0825	M8 x 25	500	HN06	M6									
200	SS0830	M8 x 30	500	HN08	M8									
200	SS0835	M8 x 35	200	HN10	M10									
200	SS0840	M8 x 40	200	HN12	M12									
200	SS0850	M8 x 50	Roofing nuts and bolts											
200	SS1016	M10 x 16	ELECTROPLATED ZINC											
200	SS1020	M10 x 20	200	RB0612	M6 x 12									
200	SS1025	M10 x 25	200	RB0616	M6 x 16									
200	SS1030	M10 x 30	200	RB0620	M6 x 20									
100	SS1035	M10 x 35	200	RB0625	M6 x 25									
100	SS1040	M10 x 40	100	RB0630	M6 x 30									
100	SS1045	M10 x 45	100	RB0640	M6 x 40									
100	SS1050	M10 x 50	100	RB0650	M6 x 50									
100	SS1060	M10 x 60	HOT DIP GALVANISED											
100	SS1220	M12 x 20	100	RBG0612	M6 x 12									
100	SS1225	M12 x 25	100	RBG0616	M6 x 16									
100	SS1230	M12 x 30	STAINLESS STEEL											
100	SS1235	M12 x 35	100	RB0612 S	M6 x 12									
100	SS1240	M12 x 40	100	RB0616 S	M6 x 16									
100	SS1250	M12 x 50	100	RB0620 S	M6 x 20									
HOT DIP GALVANISED														
200	SSG0612	M6 x 12												
200	SSG0616	M6 x 16												
200	SSG0620	M6 x 20												
200	SSG0635	M6 x 35												

Swiftrack channel support systems

standard fixings and fasteners (continued)

Flat washers	Roofing washers	Penny washers	Shakeproof washers	Tray washers	Threaded rods	Threaded rod connectors	Eye bolts
Pack	Cat. Nos.	Size		Pack	Cat. Nos.	Size	
Flat washers				Threaded rod			
ELECTROPLATED ZINC				ELECTROPLATED ZINC			
500	FW06	M6		3 m	TR06	M6 x 3 m	
500	FW08	M8		3 m	TR08	M8 x 3 m	
500	FW10	M10		3 m	TR10	M10 x 3 m	
200	FW12	M12		3 m	TR12	M12 x 3 m	
Roofing washers				Threaded rod connectors			
HOT DIP GALVANISED				ELECTROPLATED ZINC			
500	RWG06	M6		1	RC06	M6	
Penny washers				1	RC08	M8	
ELECTROPLATED ZINC				1	RC10	M10	
400	PW06	M6 x 25		1	RC12	M12	
400	PW08	M8 x 25		Eye bolts			
400	PW10	M10 x 38		ELECTROPLATED ZINC			
400	PW12	M12 x 40		1	EB06	M6 x 80	
Shakeproof washers				1	EB08	M8 x 80	
ELECTROPLATED ZINC				1	EB10	M10 x 80	
400	SW06	M6					
400	SW08	M8					
400	SW10	M10					
400	SW12	M12					
Tray washers							
ELECTROPLATED ZINC							
400	TW06	M6 x 20					
HOT DIP GALVANISED							
100	TWG06	M6 x 20					

Ceiling support system

heavy duty

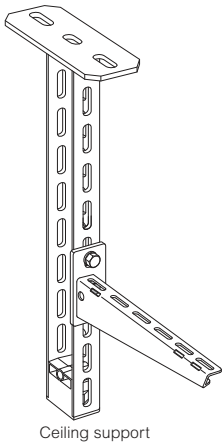

Ceiling support

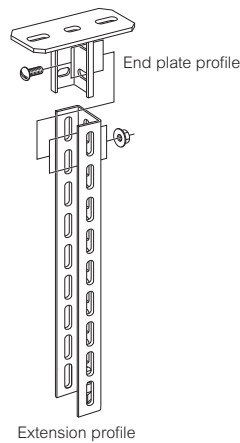

Extension profile



Dimensions and technical information (p. 109)

The dedicated ceiling support system allows for a flexible, multi-tiered approach for single or double sided loads with a maximum cantilever arm width of 700 mm to accept Swifts cable ladders up to 600 mm wide, either lidded or unlidded
Conform to IEC 61537

Pack	Cat. Nos.	Support system
Ceiling supports		
Moment 1% deflection 780 Nm		
Symmetrical load 6000 N		
Including protection end cap		
Ceiling fixings not included		
Length		
1	87665 02	200 mm
1	87665 03	300 mm
1	87665 04	400 mm
1	87665 05	500 mm
1	87665 06	600 mm
1	87665 07	700 mm
1	87665 08	800 mm
1	87665 09	900 mm
1	87665 10	1000 mm
1	87665 11	1100 mm
1	87665 12	1200 mm
1	87665 13	1300 mm
1	87665 14	1400 mm
1	87665 15	1500 mm
1	87665 16	1600 mm
1	87665 18	1800 mm
1	87665 20	2000 mm
Extension profiles		
Moment 1200 Nm		
1	87665 30	3000 mm
1	87665 45	4500 mm
Ceiling bracket		
1	87665 50	Lock to profile with 2 x M10 x 25 mm carriage bolt + washer + hexagon nut Adjustable between -30° and +30°
End plate profile		
1	87665 60	Lock to profile with 2 x M10 x 25 mm carriage bolt + washer + hexagon nut
Profile connector		
1	87665 70	Lock to profile with 4 x M10 x 20 mm hexagon bolt + washer + hexagon nut

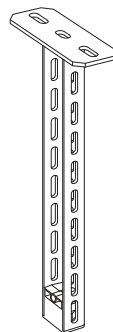

Pack	Cat. Nos.	Support system (continued)
Cantilever arms		
Fix to profile with 1 x M10 x 25 mm carriage bolt + washer + hexagon nut		
Width		
1	5572 33	200 mm
1	5572 43	300 mm
1	5572 53	400 mm
1	5572 63	500 mm
1	5572 73	600 mm
1	5573 83	700 mm

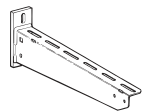

→ For fasteners, see p. 29-30

→ For technical information, see p. 109

TECHNICAL SPECIFICATIONS





IN THIS SECTION

SWIFTS CABLE LADDER SYSTEMS

Straight lengths

Medium duty (Topaz)	34
Heavy duty (Sapphire)	35
Extra heavy duty (Emerald)	36
Rung details / diagonal bracing	37

Couplers – straight lengths

Straight length to straight length couplers	38-39
Flexible expansion couplers	40
Connectors – bendable and vertical hinged	41-42

Pre-fabrication of cable ladder runs

Identification and recognition of fittings

Couplers – fittings

Integral fitting couplers	44
Fitting to fitting couplers	44-45

Fittings

Flat bends	46-49
Inside and outside risers	50-61
Equal and unequal tees	62-68
Branch pieces	69
4 way crosspieces	70-71
Straight and offset reducers	72-73

Supports

Heavy duty cantilever arms	74
Heavy duty trapeze hangers	75
Hanger rod brackets	76
Wall support brackets	77
90° end connectors	78

Ancillary items

Earth continuity connectors	79
Hold down clips and brackets	80-81
Boltable hold down brackets	82
Boltable angled hold down brackets	83
Dividers - straight / curved	84
Articulated risers	85-86
Dropout plates	87
Rail to rail dropout plates	88
Tee brackets	89
Short reducer brackets	90
Ancillary mounting brackets and plates	91-92
Cable support brackets	93
Stop ends	94

Covers

Straight lengths and fittings	95-98
-------------------------------	-------

SWIFTRACK CHANNEL SUPPORT SYSTEM

Single channels – plain and slotted	99
Back-to-back channels	100
Assembly – fasteners and channel nuts	101
Cantilever arms	102-103
Framework brackets	104-107
Beam clamps, pipe clamps and accessories	107-108

CEILING SUPPORT SYSTEM

Heavy duty	109
------------	-----

Swifts® straight lengths medium duty (Topaz)

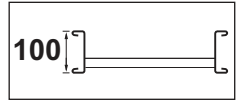

■ Dimensions and weights

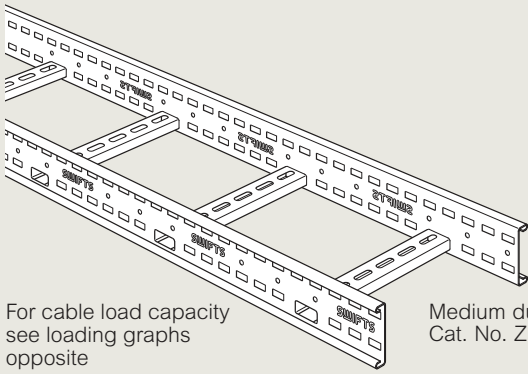

For cable load capacity see loading graphs opposite

Medium duty (Topaz)
Cat. No. ZL **W F**

Dimensions

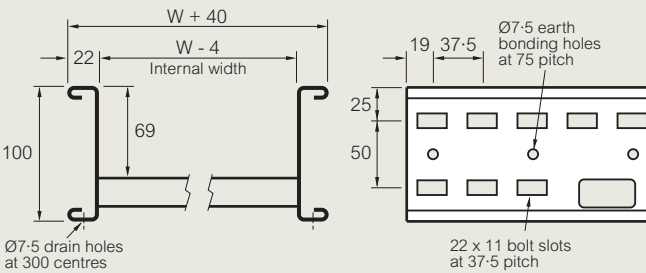
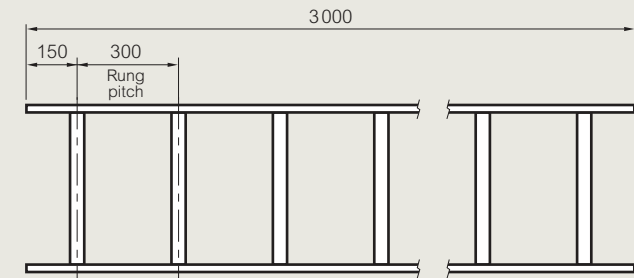

Ø7.5 drain holes at 300 centres

22 x 11 bolt slots at 37.5 pitch

Weights

Width (W)	Cat. Nos.	Weight (kg)
150	ZL 150 F	12.1
300	ZL 300 F	13.4
450	ZL 450 F	14.6
600	ZL 600 F	16.9
750	ZL 750 F	20.3
900	ZL 900 F	22.2

All weights given are in kilograms (kg) and are for a 3 m straight length in hot dip galvanised G finish
To obtain the appropriate component weight in other finishes, multiply the given weight by the following factors :
Deep galvanised (D) x 1.07
Stainless steel (S) x 0.94
Powder coated (E) x 0.97

Gauge

Standard side rail = 1.5 mm

Key : Replace the letter shown in red with your choice from the following options :

- F** = Finish : **G** (hot dip galvanised after manufacture)
- D** (deep galvanised)
- S** (stainless steel)
- E** (powder coated)

■ Loading graphs

Load tests carried out to BS EN 61537 test type 1 (safety factor 1.7+ and joint in middle of span) or test type 4 (safety factor 1.7+ and joint in middle of span with rung slot over support)

Load tests carried out over 2 m, 3 m and 4 m spans using 3 m lengths
Safe working load should include all cable loads and any other additional loads (e.g. wind, snow)

When installed, inner span deflection will vary depending on joint positions but will typically be about half of test end span deflection shown below

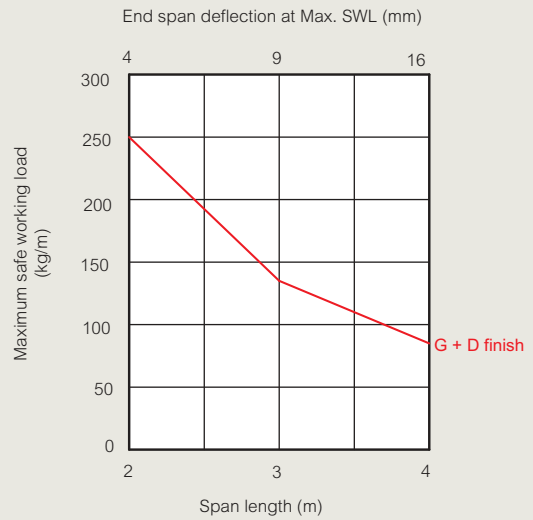

Graph showing safe working load vs span with deflections shown at SWL

■ Finishes

Standard stocked finish :

G Hot dip galvanised after manufacture to BS EN ISO 1461 : 2009

Additional finishes :

D Deep galvanised high silicon steel made from BS EN 10025-5 : 2004 Grade S355JOWP

S Stainless steel to BS EN 10088 – 2 grade 1.4404 (equivalent to 316L31)

Pickle and passivation is available to special order

E Powder coated (to customer's specification)



Sheared steel (particularly stainless steel) does have relatively sharp edges and protective gloves must be worn during handling

All dimensions (mm) are nominal

→ Rung details : see p. 37

→ Coupler sets : see p. 38-42

Swifts® straight lengths

heavy duty (Sapphire)

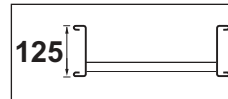

■ Dimensions and weights

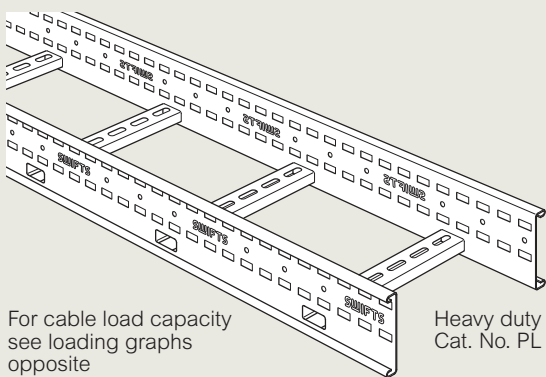

For cable load capacity see loading graphs opposite

Heavy duty (Sapphire)
Cat. No. PL **W F**

Dimensions

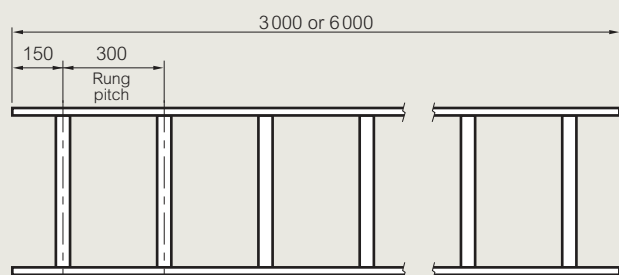

Standard length = 3000 mm (6000 mm available on special request)

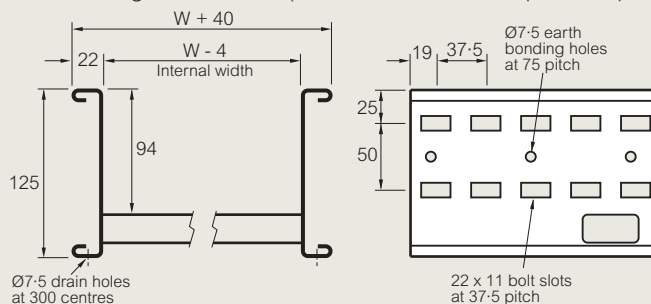

Weights

Width (W)	Cat. Nos.	Weight (kg)
150	PL 150 F	13.8
300	PL 300 F	15.0
450	PL 450 F	16.3
600	PL 600 F	18.5
750	PL 750 F	22.0
900	PL 900 F	23.9

All weights given are in kilograms (kg) and are for a 3 m straight length in hot dip galvanised G finish

To obtain the appropriate component weight in other finishes, multiply the given weight by the following factors :

Deep galvanised (D)	x 1.07
Stainless steel (S)	x 0.94
Powder coated (E)	x 0.97

Gauge

Standard side rail = 1.5 mm
Non-standard side rail = 2.0 mm

Key : Replace the letter shown in red with your choice from the following options :

- F** = Finish : **G** (hot dip galvanised after manufacture)
- D** (deep galvanised)
- S** (stainless steel)
- E** (powder coated)

■ Loading graphs

Load tests carried out to BS EN 61537 test type 1 (safety factor 1.7+ and joint in middle of span) or test type 4 (safety factor 1.7+ and joint in middle of span with rung slot over support)

Load tests carried out over 3 m, 4 m and 5 m spans using 3 m lengths and 6 m spans using 6 m lengths

Safe working load should include all cable loads and any other additional loads (e.g. wind, snow)

For spans greater than 5 m : data is for 6 m long ladders only

For spans 5 m and less : data can be used for 3 m or 6 m long lengths

For spans greater than 5 m : ladder is not suitable for use with dynamic loads (e.g. wind, snow)

When installed, inner span deflection will vary depending on joint positions but will typically be about half of test end span deflection shown below

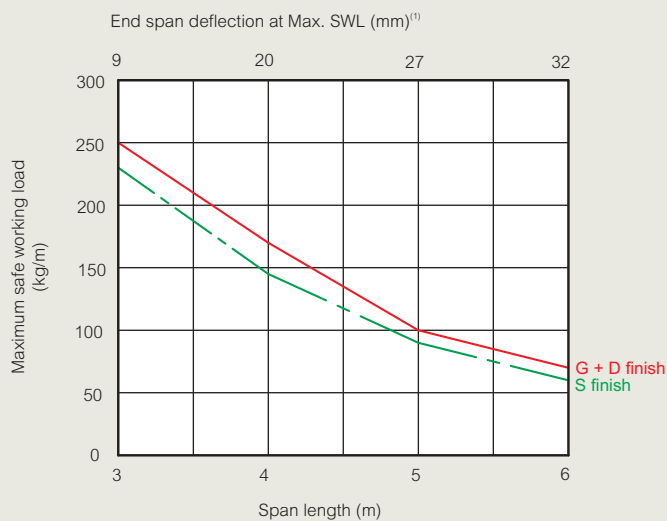

Graph showing safe working load vs span with deflections shown at SWL

(1) Deflections shown for G finish. D and S finish deflections on application, please contact us on +44 (0) 845 605 4333

■ Finishes

Standard stocked finish :

G Hot dip galvanised after manufacture to BS EN ISO 1461 : 2009

Additional finishes :

D Deep galvanised high silicon steel made from BS EN 10025-5 : 2004 Grade S355JOWP

S Stainless steel to BS EN 10088 – 2 grade 1.4404 (equivalent to 316L31)
Pickle and passivation is available to special order

E Powder coated (to customer's specification)



Sheared steel (particularly stainless steel) does have relatively sharp edges and protective gloves must be worn during handling

All dimensions (mm) are nominal

→ Rung details : see p. 37

→ Coupler sets : see p. 38-42

Swifts® straight lengths

extra heavy duty (Emerald)

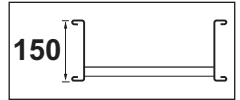

Extra heavy duty (Emerald)

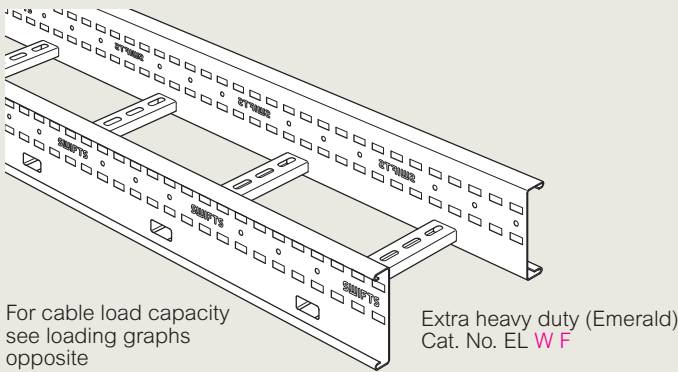

For cable load capacity see loading graphs opposite

Extra heavy duty (Emerald)
Cat. No. EL **W F**

Dimensions

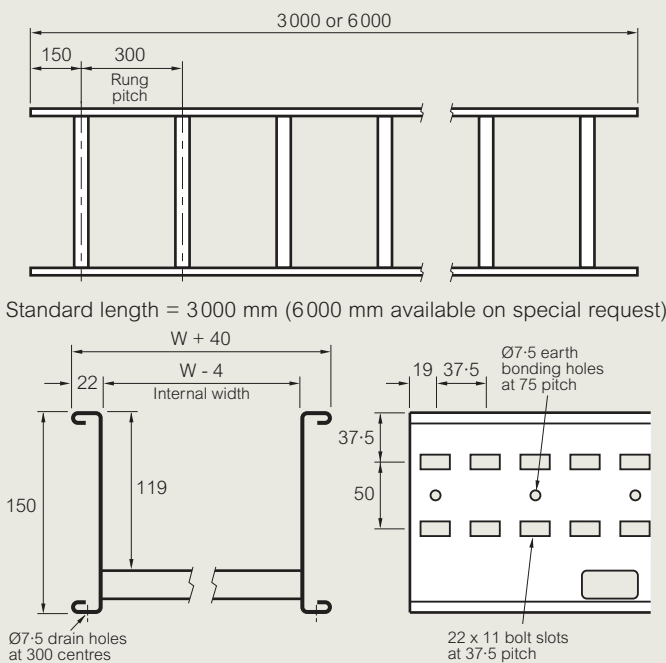

Standard length = 3000 mm (6000 mm available on special request)

Weights

Width (W)	Cat. Nos.	Weight (kg)
150	EL 150 F	20.7
300	EL 300 F	22.1
450	EL 450 F	23.5
600	EL 600 F	25.0
750	EL 750 F	28.8
900	EL 900 F	30.8

All weights given are in kilograms (kg) and are for a 3m straight length in hot dip galvanised G finish
To obtain the appropriate component weight in other finishes, multiply the given weight by the following factors :

- Deep galvanised (D) x 1.07
- Stainless steel (S) x 0.94
- Powder coated (E) x 0.97

Gauge

Standard side rail = 2.0 mm

Key : Replace the letter shown in red with your choice from the following options :

- F** = Finish : **G** (hot dip galvanised after manufacture)
- D** (deep galvanised)
- S** (stainless steel)
- E** (powder coated)

Loading graphs

Load tests carried out to BS EN 61537 test type 1 (safety factor 1.7+ and joint in middle of span) or test type 4 (safety factor 1.7+ and joint in middle of span with rung slot over support)

Load tests carried out over 3 m, 4 m and 5 m spans using 3 m lengths and 6 m spans using 6 m lengths

Safe working load should include all cable loads and any other additional loads (e.g. wind, snow)

For spans greater than 5 m : data is for 6 m lengths only

For spans 5 m and less : data can be used for 3 m or 6 m lengths

For spans greater than 5 m : ladder is not suitable for use with dynamic loads (e.g. wind, snow)

When installed, inner span deflection will vary depending on joint positions but will typically be about half of test end span deflection shown below

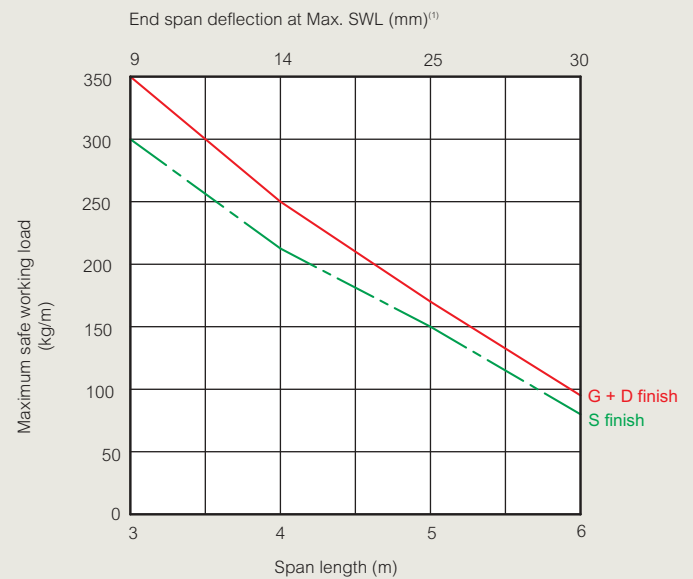

Graph showing safe working load vs span with deflections shown at SWL

(1) Deflections shown for G finish, D and S finish deflections on application, please contact us on +44 (0) 845 605 4333

Finishes

Standard stocked finish :

G Hot dip galvanised after manufacture to BS EN ISO 1461 : 2009

Additional finishes :

D Deep galvanised high silicon steel made from BS EN 10025-5 : 2004 Grade S355JOWP

S Stainless steel to BS EN 10088 - 2 grade 1.4404 (equivalent to 316L31)

Pickle and passivation is available to special order

E Powder coated (to customer's specification)



Sheared steel (particularly stainless steel) does have relatively sharp edges and protective gloves must be worn during handling

All dimensions (mm) are nominal

→ Rung details : see p. 37

→ Coupler sets : see p. 38-42

Swifts® cable ladder rungs for straight lengths and fittings

■ Rung details

Type 1 rungs are used as standard

Type 2 and 3 are only available to special order
Type 3 is not available in deep galvanised finish
Types 1 and 3 can be supplied in any combination to special order

■ Options and dimensions

Standard

Type 1

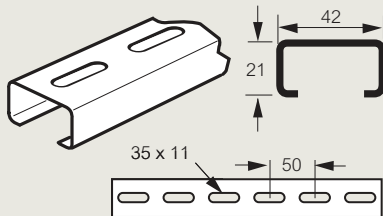

Special order only

Type 2

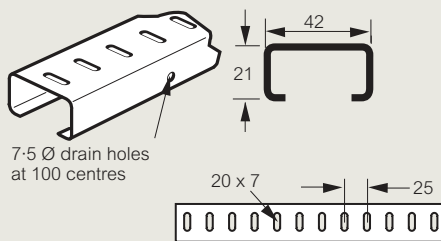

Type 3

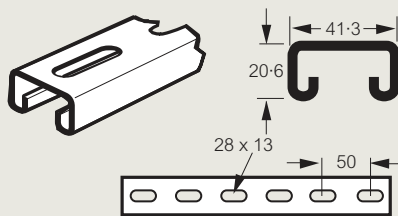

Slot pattern may differ on stainless steel type 3 rungs
Contact us on +44 (0) 845 605 4333

All dimensions (mm) are nominal

Swifts® cable ladder systems diagonal bracing – straight lengths

■ Diagonal bracing

The effect of lateral loads on spans over 5 m or 6 m can be much reduced by adding diagonal bracing

Bracing is achieved by fitting a ladder Type 1 rung section, cut to length from a 3 m length supplied, diagonally across the underside of the ladder as shown in the illustration below. Diagonal bracing can be fitted to either heavy duty (Sapphire) or extra heavy duty (Emerald) ladders – medium duty (Topaz) is not suited to these long spans

■ Installation (typical)

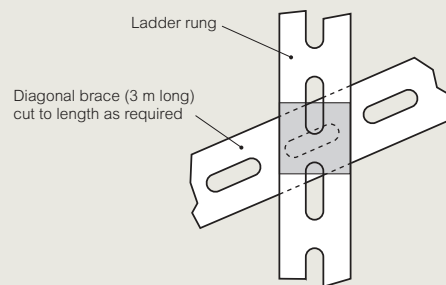
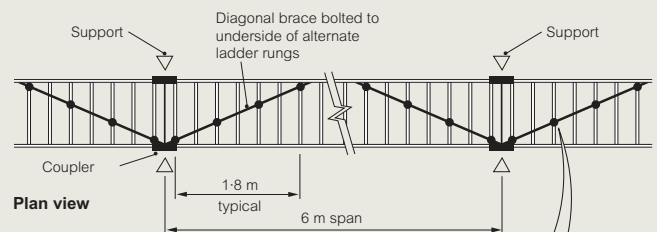

Couplers are best located over the point of support to provide additional local reinforcement of the ladder side rails. Details on long span installations are given on p. 129

■ Assembly

Fasteners (not included)

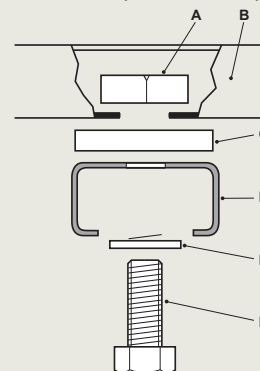

- A M10 Swiftrack channel nut (PN 100)
- B Ladder rung
- C 40 x 40 x 6 square washer, Cat. No. SB506/10
- D Diagonal brace (type 1 rung)
- E M10 form A washer
- F M10 x 25 Grade 8.8 setscrew hot dip galvanised

Fastener finishes

For ladders with S finish, fasteners are corrosion resistant stainless Grade A470

Swifts® cable ladder couplers and fasteners

straight length to straight length couplers

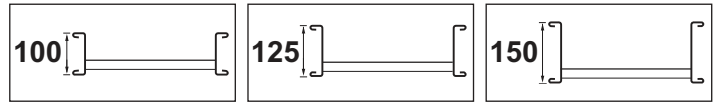

Couplers are used for joining together straight lengths in the medium duty (Topaz), heavy duty (Sapphire) and extra heavy duty (Emerald) ranges

Fittings in these ranges have integral couplers. See p. 44 for more information

Even when ladders are cut to length, the slots in the coupler will always align with the slots in the ladder side rail

Supplied in pairs with the appropriate quantity of fasteners

■ Installation (typical)

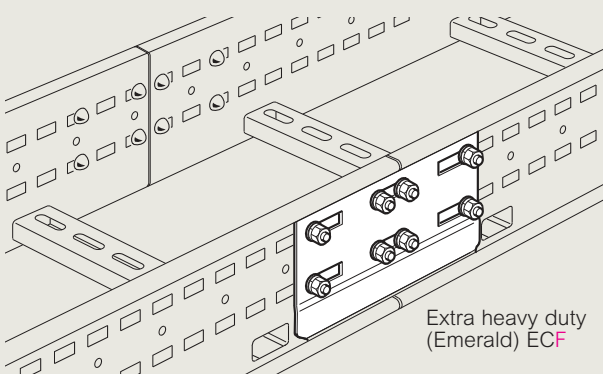
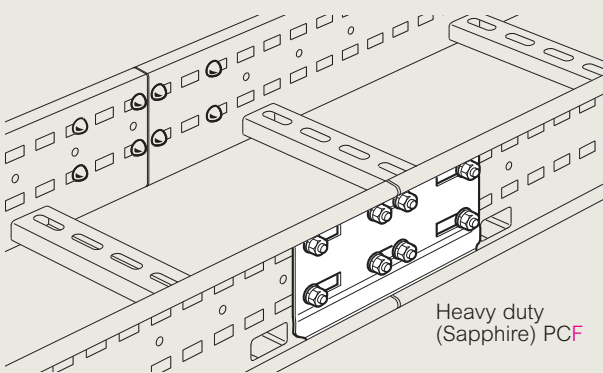
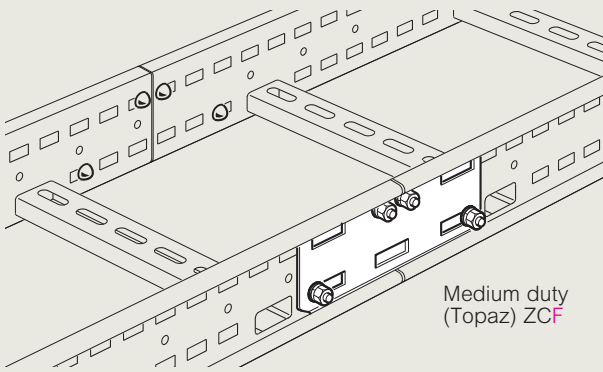

Joggles are formed in the bottom of PC and EC couplers to allow easy installation of ladder cut lengths

■ Assembly

Slide the couplers under the return flanges of one ladder side rail and loosely fit a single fastener to each coupler to hold it in place. Slide the second ladder over both couplers, adjust each coupler position to align the slots with the side rail slots and secure with all fasteners

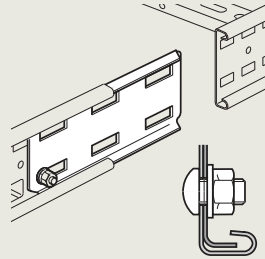

Note

Bolts should be inserted through the side rail first. For location of coupler and position of fasteners, see below

Fastener positioning

Medium duty (Topaz)

Supplied in pairs, with fasteners (4 per coupler)

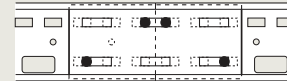

When bolting to cut ends adjust coupler to ensure 4 bolts can be inserted

Note

When connecting straight lengths to straight lengths even when ladder is cut to length, the slots in the coupler will always align with slots in the ladder side rail

Heavy duty (Sapphire) and extra heavy duty (Emerald)

Supplied in pairs, with fasteners (8 per coupler)

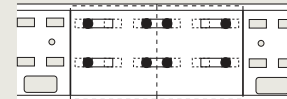

When bolting to cut ends adjust coupler to ensure 8 bolts can be inserted

Note

When connecting straight lengths to straight lengths even when ladder is cut to length, the slots in the coupler will always align with slots in the ladder side rail

Cat. Nos.	Ladder range		
	Topaz	Sapphire	Emerald
	ZCF	PCF	ECF
Quantity of fasteners per coupler	4	8	8

When connecting straight lengths to fittings, use fastener sets, see p. 44

For additional types of straight length to straight length couplers and fasteners, see p. 39-42

Key : Replace the letter shown in red with your choice from the following options :

F = Finish : G (hot dip galvanised after manufacture)
 D (deep galvanised)
 S (stainless steel)
 E (powder coated)

All dimensions (mm) are nominal

→ Straight lengths : see p. 34-36

→ Finishes and standards : see p. 34-36

■ Assembly (continued)

Fasteners (included)

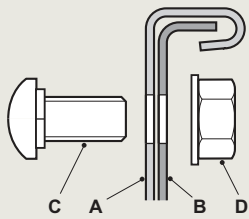

- A Side rail
- B Coupler
- C M10 x 20 coachbolt
- D M10 flange nut

Recommended Torque Setting (M10): 40Nm

Fastener finishes

For ladders with G, D and E finishes, fasteners are high tensile Grade 8.8 hot dip galvanised

For ladders with S finish, fasteners are corrosion resistant stainless Grade A470

An alternative material for fasteners may be required depending on the installation environment - contact us on +44 (0) 845 605 4333

■ Dimensions and weights

Medium duty
(Topaz) ZCF

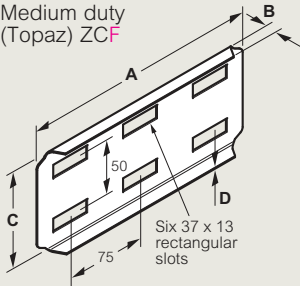

Heavy duty
(Sapphire) PCF

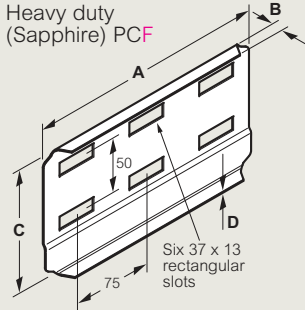

Extra heavy duty
(Emerald) ECF

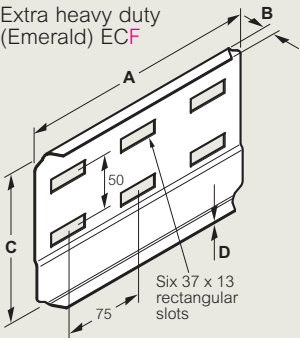

Cat. Nos.	A	B	C	D	Weight (kg)
ZCF	220	13	95	1.5	0.6
PCF	220	13	119	2.0	1.0
ECF	220	13	144	2.0	1.2

Weights

All weights given are in kilograms (kg) and are for a pair of couplers in hot dip galvanised G finish

To obtain the appropriate component weight in other finishes, multiply the given weight by the following factors :

- Deep galvanised (D) x 1.07
- Stainless steel (S) x 0.94
- Powder coated (E) x 0.97

Swifts® cable ladder couplers and fasteners

flexible expansion couplers

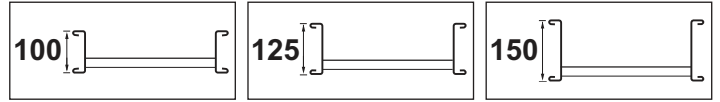

Flexible expansion couplers can be used to :

- provide a semi-flexible joint where ladder runs span separate structures between which some relative movement is possible
- provide compensation for changes in the length of a straight cable ladder run due to temperature variations

Supplied in pairs with fasteners

Installation (typical)

Normal installation

Heavy duty (Sapphire)
PEF (ZEF and
EEF similar)

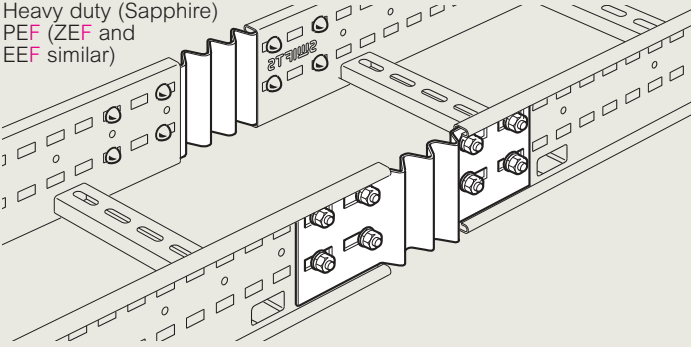

Stiffened installation

Heavy duty (Sapphire)
PEF (ZEF and
EEF similar)

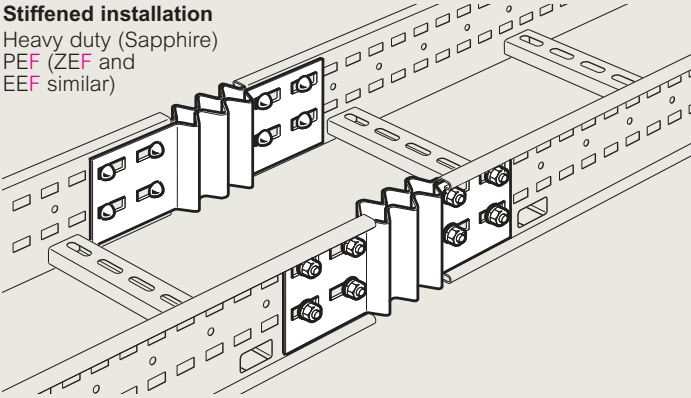

Flexible expansion couplers should normally be installed with the ridges facing outward, away from the bed of the ladder

If necessary, the stiffness of each joint can be increased by mounting pairs of couplers back-to-back (with one set of ridges facing inwards and the other set facing outwards as shown above) on either side of the cable ladder. The allowance for differential movement remains unchanged (see below)

Note

Rigid support for the cable ladder should be provided on both sides adjacent to each joint

Assembly

Each joint formed by flexible expansion couplers provides for up to 10 mm of linear movement between the two adjacent ladders

To calculate the ideal distance between flexible expansion coupler installations use the formula : $L = \frac{K_S}{T}$

Where : L = distance between flexible expansion couplers, in metres
 K_S = 909 for mild steel, 625 for stainless steel
 T = temperature range (in °C) for which allowance is to be made

Note

Coefficients of linear expansion : mild steel = $11 \times 10^{-6}/^\circ\text{C}$
 stainless steel = $16 \times 10^{-6}/^\circ\text{C}$

Key : Replace the letter shown in red with your choice from the following options :

- F = Finish : **G** (hot dip galvanised after manufacture)
D (deep galvanised)
S (stainless steel)
E (powder coated)

Assembly (continued)

Fasteners (included)

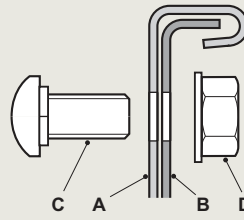

- A Side rail
- B Coupler
- C M10 x 20 coachbolt
- D M10 flange nut

Recommended Torque Setting (M10): 40Nm

Fastener finishes

For ladders with G, D and E finishes, fasteners are high tensile Grade 8.8 hot dip galvanised

For ladders with S finish, fasteners are corrosion resistant stainless Grade A470

An alternative material for fasteners may be required depending on the installation environment - contact us on +44 (0) 845 605 4333

Cat. Nos.	Ladder range		
	Topaz	Sapphire	Emerald
	ZEF	PEF	EEF
Quantity of fasteners per coupler ⁽¹⁾	4	8	8

(1) for normal installation, or per pair (each side) for stiffened installation

Dimensions and weights

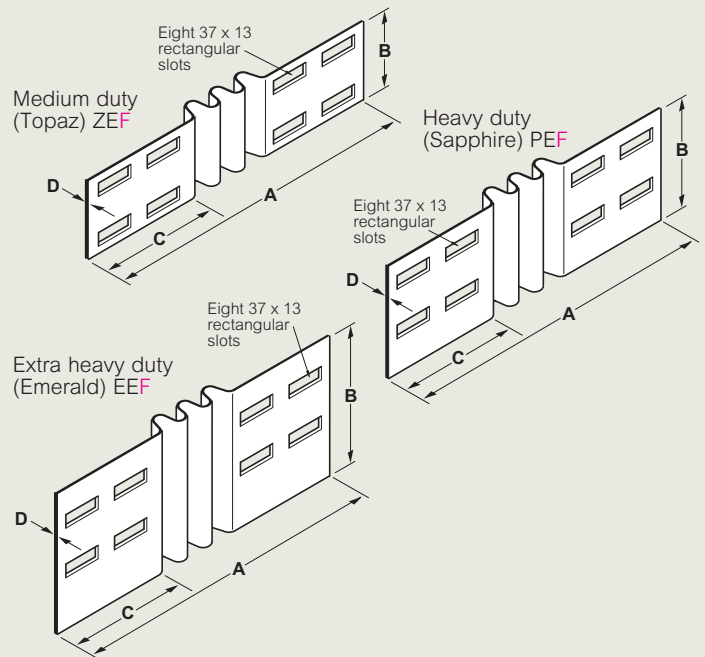

Cat. Nos.	A	B	C	D	Weight (kg)
ZEF	320	84	113.0	1.0	0.6
PEF	317	115	111.5	1.5	1.1
EEF	317	138	111.5	1.5	1.4

Weights

All weights given are in kilograms (kg) and are for a pair of couplers in hot dip galvanised G finish

To obtain the appropriate component weight in other finishes, multiply the given weight by the following factors :

- Deep galvanised (D) x 1.07
- Stainless steel (S) x 0.94
- Powder coated (E) x 0.97

All dimensions (mm) are nominal

→ Straight lengths : see p. 34-36

→ Finishes and standards : see p. 34-36

Swifts® cable ladder couplers and fasteners bendable connectors

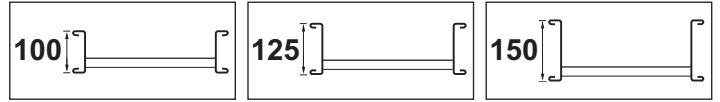

Bendable connectors can be used for :

- a. fabricating fittings on site from cut lengths of cable ladder
 - b. reducing width of a run to the next size down when a properly manufactured reducer is not available
 - c. correcting minor mis-alignment problems
 - d. coupling lengths of ladder to form articulated bends
- Bendable connectors are supplied in pairs with fasteners

Installation (typical)

Heavy duty (Sapphire)
PHF (ZHF and EHF similar)

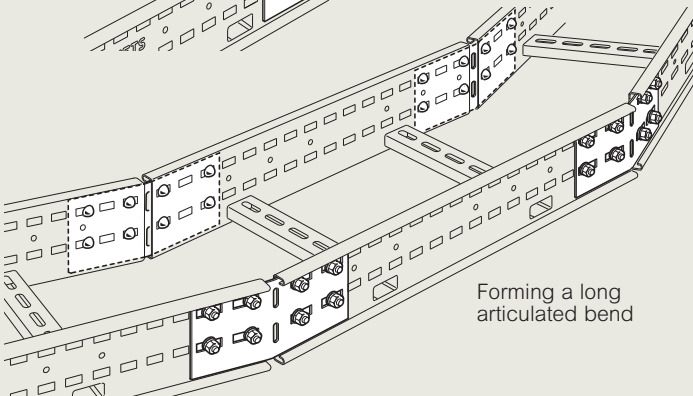
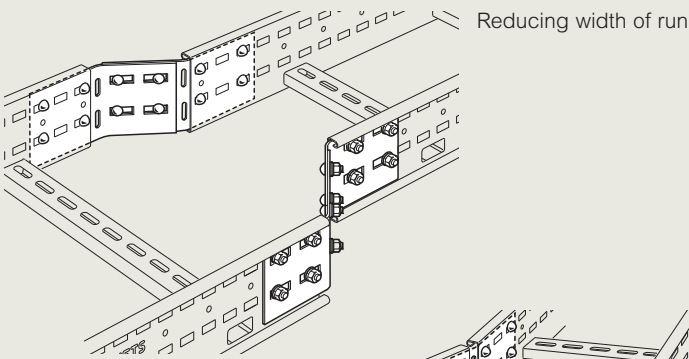
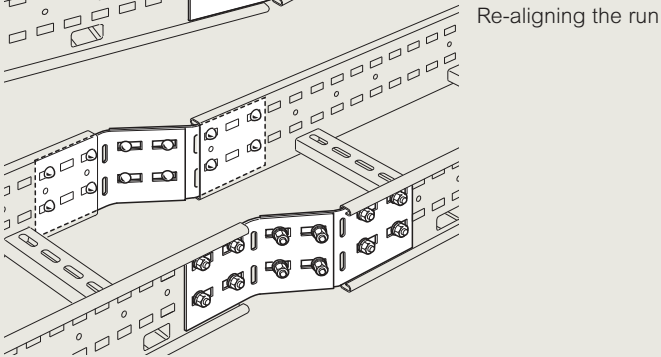
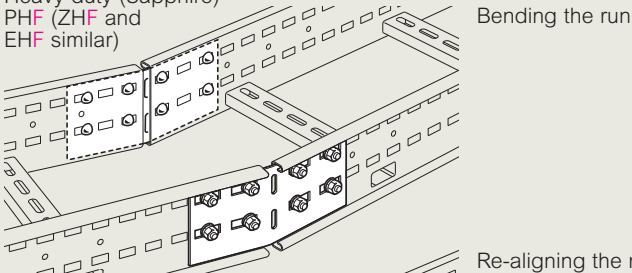

Note

Rigid support for the cable ladder should be provided on both sides adjacent to each joint

Key : Replace the letter shown in red with your choice from the following options :

- F = Finish : G (hot dip galvanised after manufacture)
D (deep galvanised)
S (stainless steel)
E (powder coated)

Assembly

Fasteners (included)

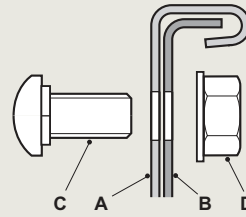

- A Side rail
- B Coupler
- C M10 x 20 coachbolt
- D M10 flange nut

Recommended Torque Setting (M10): 40Nm

Fastener finishes

For ladders with G, D and E finishes, fasteners are high tensile Grade 8.8 hot dip galvanised

For ladders with S finish, fasteners are corrosion resistant stainless Grade A470

An alternative material for fasteners may be required depending on the installation environment - contact us on +44 (0) 845 605 4333

Cat. Nos.	Ladder range		
	Topaz ZHF	Sapphire PHF	Emerald EHF
Quantity of fasteners per connector	4	8	8
per additional connector	2	4	4

Dimensions and weights

Medium duty (Topaz) ZHF

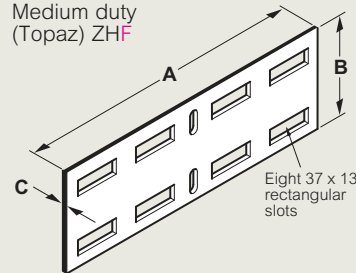

Heavy duty (Sapphire) PHF

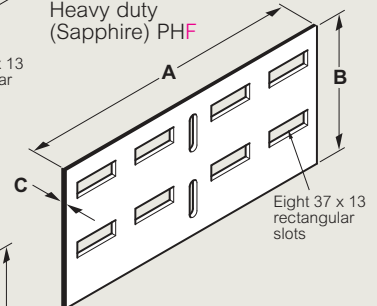

Extra heavy duty (Emerald) EHF

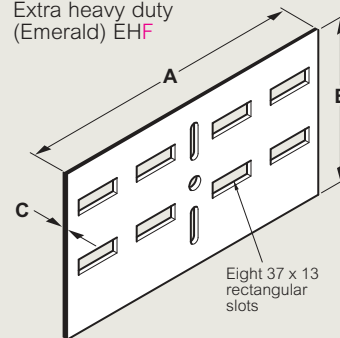

Cat. Nos.	A	B	C	Weight (kg)
ZHF	250	84	1.5	0.5
PHF	250	115	1.5	0.7
EHF	250	140	1.5	0.8

Weights

All weights given are in kilograms (kg) and are for a pair of couplers in hot dip galvanised G finish

To obtain the appropriate component weight in other finishes, multiply the given weight by the following factors :

- Deep galvanised (D) x 1.07
- Stainless steel (S) x 0.94
- Powder coated (E) x 0.97

All dimensions (mm) are nominal

→ Straight lengths : see p. 34-36

→ Finishes and standards : see p. 34-36

Swifts® cable ladder couplers and fasteners

vertical hinged connectors

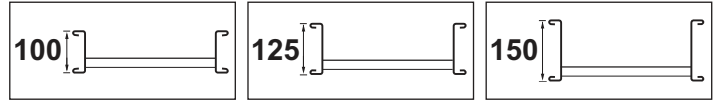

Vertical hinged connectors can be used for :

- fabricating fittings on site from cut lengths of cable ladder
- solving minor vertical mis-alignment problems
- coupling articulated risers to adjacent ladders

Supplied in sets comprising four plates and fasteners

Installation (typical)

Heavy duty (Sapphire)
PVF (ZVF and EVF similar)

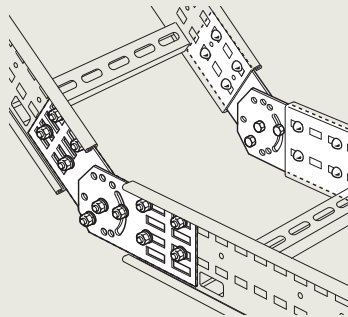

Assembly

Vertical hinged connectors can either be connected together to form pre-set angles or pre-assembled for adjustment in situ

Assembly to a pre-set angle

- identify the correct outer fixing holes for the required pre-set angle (see table and illustration below)
- insert a fastener through the identified holes in both plates and fit a locking washer and nut but do not fully tighten
Do not insert fasteners through the centre hole first, this makes identification of the outer holes very difficult
- move the two connectors to align the centre holes. Insert a fastener through the holes and fit a locking washer and nut **but do not fully tighten**
- insert a third fastener through a slot in one connector and an aligning hole in the other. Fit a locking washer and nut
- tighten all fasteners

Cat. Nos.	15°	18°	22.5°	30°	45°
ZVF, PVF, EVF	G : C	A : F	E : B	B : G	F : C

ZVF, PVF, EVF

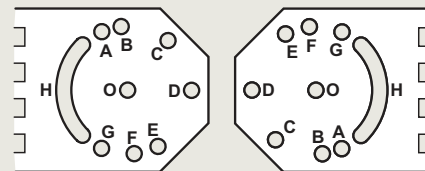

Pre-assembly for adjustment in-situ

- insert a fastener through the outer hole of both connectors. Fit a locking washer and nut and tighten sufficiently to hold the assembly together while it is carried to the installation position
- fit the assembly to the installed ladders
- insert a second fastener through the slot in one connector and an aligning hole and fit a locking washer and nut
- if possible, insert a third fastener through either the alternate slot and an aligning hole, or two aligning holes. Fit a locking washer and nut
- tighten all fasteners

Connector to ladder fasteners (included)

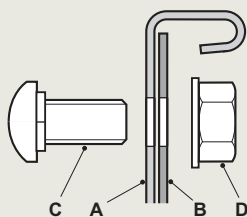

- A Side rail
- B Connector
- C M10 x 20 coachbolt
- D Flange nut

Key : Replace the letter shown in red with your choice from the following options :

- F = Finish : G (hot dip galvanised after manufacture)
- D (deep galvanised)
- S (stainless steel)
- E (powder coated)

Assembly (continued)

Connector to connector fasteners (included)

ZVF

PVF, EVF

- A M6 x 16 setscrews
- B M6 washer
- C M6 shakeproof washer
- D Connector
- E M6 nut
- F M10 x 20 setscrews
- G M10 form A washer
- H Flange nut

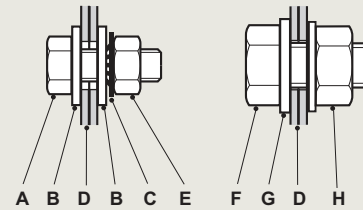

Recommended Torque Setting (M10): 40Nm

Fastener finishes

For ladders with G and D finishes, fasteners are high tensile Grade 8.8
For ladders with S finish, fasteners are corrosion resistant stainless Grade A470
For ladders with E finish, the fasteners are Grade 8.8 hot dip galvanised
An alternative material for fasteners may be required depending on the installation environment - contact us on +44 (0) 845 605 4333

Cat. Nos.	Ladder range		
	Topaz ZVF	Sapphire PVF	Emerald EVF
Quantity of fasteners per connector to ladder	2 x M10	4 x M10	4 x M10
per connector to connector	3 x M6	3 x M10	3 x M10

Dimensions and weights

Medium duty (Topaz) ZVF

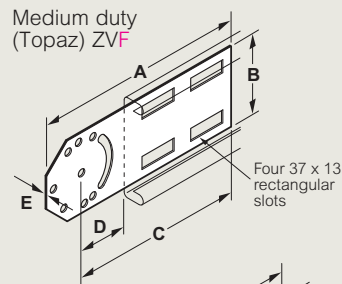

Heavy duty (Sapphire) PVF

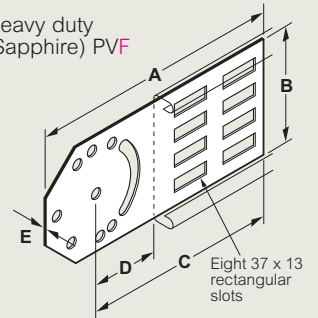

Extra heavy duty (Emerald) EVF

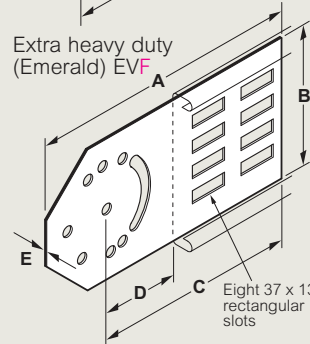

Cat. Nos.	A	B	C	D	E	Weight (kg)
ZVF	212	80	172.0	50.0	1.5	0.8
PVF	250	115	192.5	71.0	2.0	1.5
EVF	270	140	201.0	79.5	2.0	2.0

Weights

All weights given are in kilograms (kg) and are for a set of four plates in hot dip galvanised G finish

To obtain the appropriate component weight in other finishes, multiply the given weight by the following factors :

- Deep galvanised (D) x 1.07
- Stainless steel (S) x 0.94
- Powder coated (E) x 0.97

All dimensions (mm) are nominal

→ Articulated risers : see p. 85-86

→ Finishes and standards : see p. 34-36

Swifts® cable ladder systems

pre-fabrication of cable ladder runs

To assist in the installation of a complete cable ladder run following a centre-line drawing (usually CAD generated), the technical fitting pages for each fitting contain C, X, Y and length dimensions where appropriate, and also diagrams to explain the dimensions

The dimensions help to ensure that fittings are correctly positioned in line with the drawing and make it possible to accurately calculate the installed length of intermediate straight sections. This allows the sections to be cut to length and pre-assembled, making installation in elevated or restricted areas much simpler

A simple layout is illustrated at the bottom of the page to show how available dimensions can be used

C dimension

The C dimension is given for bends and risers in cable ladder ranges. It is the length of the centre-line from each 'end' of the fitting to the point at which the centre-lines intersect, as shown below

Bend (typical)

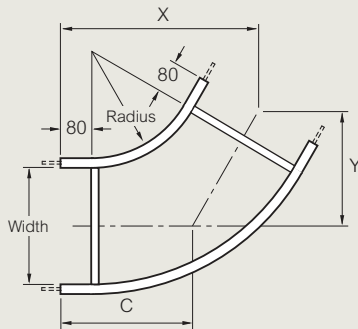

Riser (typical)

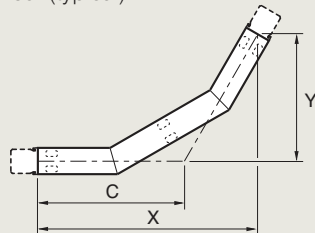

X and Y dimensions

X and Y dimensions are given for all cable ladder fittings other than reducers and straight lengths (see examples shown)

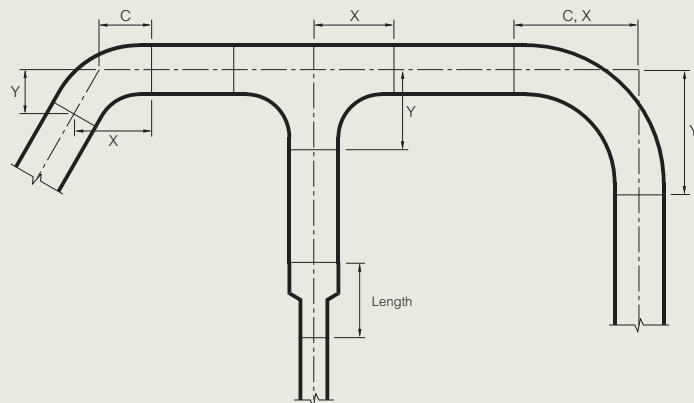

All dimensions (mm) are nominal

→ Fittings : see p. 46-73

→ Straight lengths : see p. 34-36

Swifts® cable ladder systems

identification and recognition – fittings

Under site conditions it is often difficult to distinguish between different fittings, particularly bends and risers of varying widths and radii. To assist identification, key dimension values are given on each relevant technical fitting page to provide a simple means of differentiating between similar fittings

Width

The available widths, or combinations of widths for all fittings are always listed and are a necessity for positive identification

i dimension

This dimension identifies those fittings in the cable ladder ranges which have curved sections or change the direction of the run through varying angles. It is the measurement across the inner curve of the fitting, as shown below, and is a constant for each available radius option

Bend

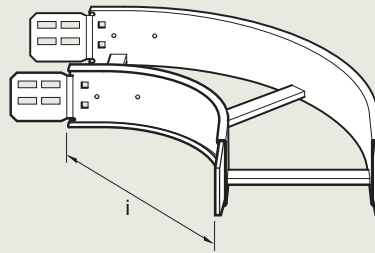

Riser

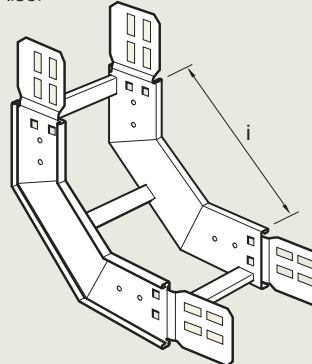

Equal tee, unequal tee, crosspiece

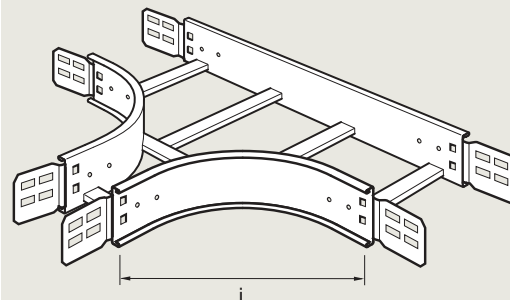

X, Y and C dimensions

For cable ladder fittings without an I dimension, the X, Y and C dimensions (where applicable) can be used. These are listed in each relevant technical fitting page and explained on the following page

Swifts® cable ladder couplers and fasteners

integral fitting couplers and fitting to fitting couplers

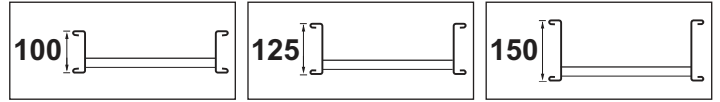

■ Integral fitting couplers

All ladder fittings have integral couplers
 For straight length to fitting connections, see below
 For fitting to fitting connections, see opposite

■ Assembly

For straight length to fitting connections, use fasteners sets, see table below for number of fasteners required per fitting type
 For fitting to fitting couplers, see opposite

Fastener positioning

Medium duty (Topaz)

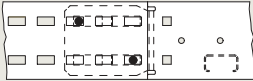

Heavy duty (Sapphire) and extra heavy duty (Emerald)

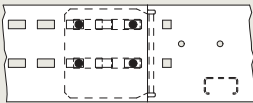

Fastener sets comprise 50 of each of the following : M10 coach bolt and flange nut

Number of fasteners required per fitting type	Sapphire and Emerald	
	Topaz	Sapphire and Emerald
Flat bends	8	16
Inside / outside risers	8	16
Reducers	8	16
Tees	12	24
4 way crosspieces	16	32

Fastener detail and finishes, see opposite

■ Dimensions

Medium duty (Topaz) end detail

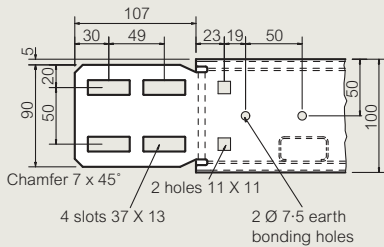

Heavy duty (Sapphire) end detail

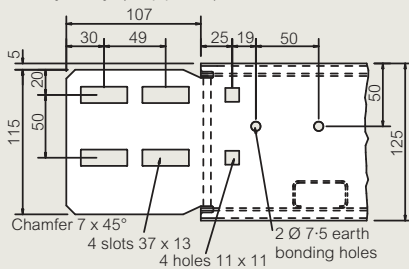

Extra heavy duty (Emerald) end detail

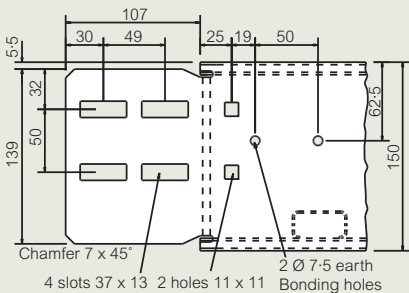

■ Fitting to fitting couplers

Fitting to fitting couplers are used for joining together cable ladder fittings (bends, tees, risers etc) in the medium duty (Topaz), heavy duty (Sapphire) and extra heavy duty (Emerald) ranges. Fittings in these ranges have integral couplers. See opposite for more information. Supplied in pairs with the appropriate quantity of fasteners

■ Installation (typical)

Medium duty (Topaz) ZFCF

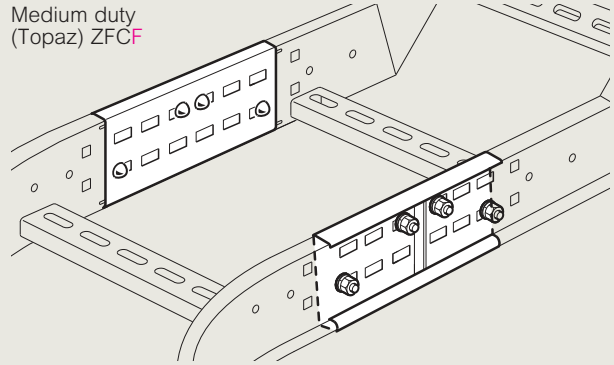

Heavy duty (Sapphire) PFCF

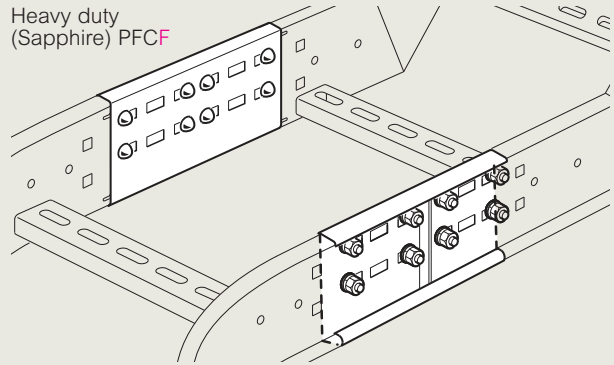

Extra heavy duty (Emerald) EFCF

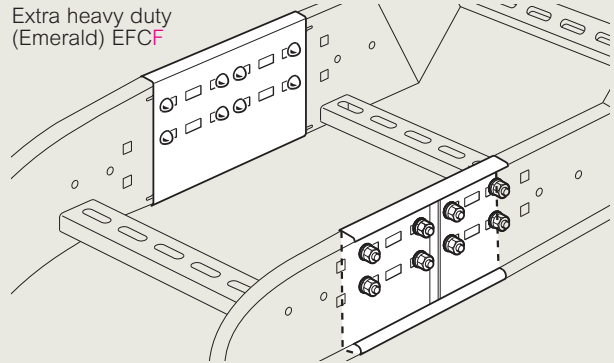

Key : Replace the letter shown in red with your choice from the following options :

- F = Finish : G (hot dip galvanised after manufacture)
- D (deep galvanised)
- S (stainless steel)
- E (powder coated)

All dimensions (mm) are nominal

➔ Straight lengths : see p. 34-36

➔ Fittings : see p. 46-73

➔ Finishes and standards : see p. 34-36

■ Assembly

Slide the couplers under the return flanges of one ladder side rail and loosely fit a single fastener to each coupler to hold it in place. Slide the second ladder over both couplers, adjust each coupler position to align the slots with the side rail slots and secure with all fasteners.

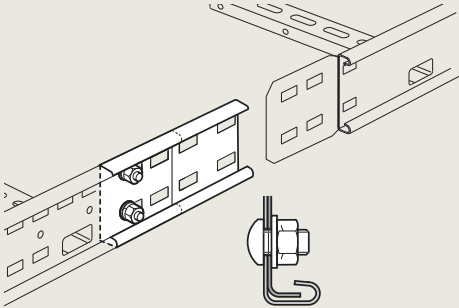

Note

For location of coupler and position of fasteners, see below.

Fastener positioning

Medium duty (Topaz)

Supplied in pairs, with fasteners (4 per coupler)

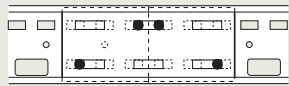

Heavy duty (Sapphire) and extra heavy duty (Emerald)

Supplied in pairs, with fasteners (8 per coupler)

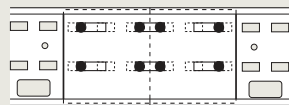

Cat. Nos.	Ladder range		
	Topaz	Sapphire	Emerald
Quantity of fasteners per coupler	4	8	8

Note

When connecting straight lengths to fittings, use fastener sets, see opposite.

Fasteners (included)

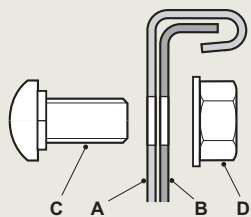

- A Side rail
- B Coupler
- C M10 x 20 coachbolt
- D M10 flange nut

Recommended Torque Setting (M10): 40Nm

Fastener finishes

For ladders with G, D and E finishes, fasteners are high tensile Grade 8.8 hot dip galvanised.

For ladders with S finish, fasteners are corrosion resistant stainless Grade A470.

An alternative material for fasteners may be required depending on the installation environment - contact us on +44 (0) 845 605 4333.

■ Dimensions and weights

Medium duty (Topaz) ZFCF

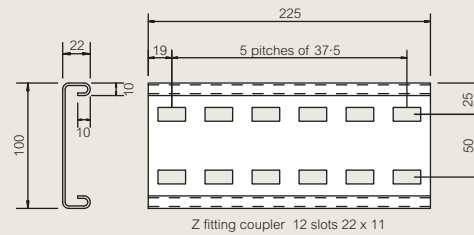

Heavy duty (Sapphire) PFCF

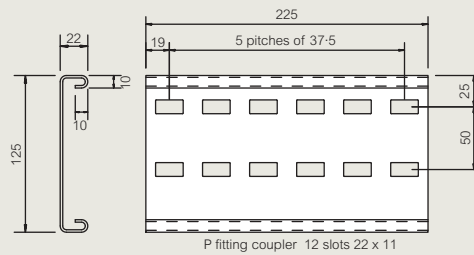

Extra heavy duty (Emerald) EFCF

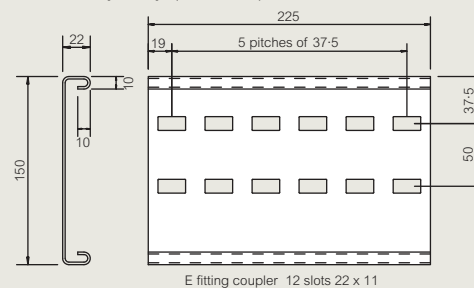

Cat. Nos.	Weight (kg)
ZFCF	0.6
PFCF	1.1
EFCF	1.4

Weights

All weights given are in kilograms (kg) and are for a pair of couplers in hot dip galvanised G finish.

To obtain the appropriate component weight in other finishes, multiply the given weight by the following factors:

- Deep galvanised (D) x 1.07
- Stainless steel (S) x 0.94
- Powder coated (E) x 0.97

Swifts® 90° flat bends

medium duty (Topaz), heavy duty (Sapphire) and extra heavy duty (Emerald)

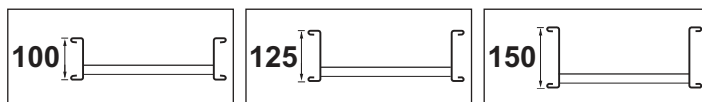

■ Dimensions and weights

Width (W)	Radius (R)	Cat. Nos.	No. of rungs	Dimensions (mm)				Weight (kg)		
				X	Y	i	C	Topaz	Sapphire	Emerald
150	300	XFB 150 90 300 F	3	453	453	537	453	3.7	4.3	6.3
	450	XFB 150 90 450 F	3	603	603	750	603	4.7	5.4	8.0
	600	XFB 150 90 600 F	4	753	753	962	753	5.7	6.6	9.7
	750	XFB 150 90 750 F	4	903	903	1174	903	6.7	7.7	11.3
	900	XFB 150 90 900 F	4	1053	1053	1386	1053	7.6	8.8	12.9
300	300	XFB 300 90 300 F	3	528	528	537	528	4.6	5.2	7.5
	450	XFB 300 90 450 F	3	678	678	750	678	5.5	6.3	9.1
	600	XFB 300 90 600 F	4	828	828	962	828	6.7	7.7	11.0
	750	XFB 300 90 750 F	4	978	978	1174	978	7.6	8.8	12.6
	900	XFB 300 90 900 F	5	1128	1128	1386	1128	8.8	10.1	14.5
450	300	XFB 450 90 300 F	3	603	603	537	603	5.4	6.1	8.7
	450	XFB 450 90 450 F	4	753	753	750	753	6.7	7.6	10.7
	600	XFB 450 90 600 F	4	903	903	962	903	7.7	8.7	12.3
	750	XFB 450 90 750 F	5	1053	1053	1174	1053	9.0	10.2	14.3
	900	XFB 450 90 900 F	5	1203	1203	1386	1203	9.9	11.3	15.9
600	300	XFB 600 90 300 F	4	678	678	537	678	7.1	8.0	10.8
	450	XFB 600 90 450 F	4	828	828	750	828	8.1	9.1	12.4
	600	XFB 600 90 600 F	5	978	978	962	978	9.6	10.8	14.6
	750	XFB 600 90 750 F	5	1128	1128	1174	1128	10.6	11.8	16.2
	900	XFB 600 90 900 F	5	1278	1278	1386	1278	11.5	12.9	17.8
750	300	XFB 750 90 300 F	4	753	753	537	753	9.0	9.9	12.9
	450	XFB 750 90 450 F	5	903	903	750	903	10.9	11.9	15.5
	600	XFB 750 90 600 F	5	1053	1053	962	1053	11.8	13.0	17.1
	750	XFB 750 90 750 F	5	1203	1203	1174	1203	12.8	14.1	18.7
	900	XFB 750 90 900 F	6	1353	1353	1386	1353	14.6	16.1	21.3
900	300	XFB 900 90 300 F	5	828	828	537	828	11.3	12.3	15.6
	450	XFB 900 90 450 F	5	978	978	750	978	12.3	13.4	17.2
	600	XFB 900 90 600 F	5	1128	1128	962	1128	13.2	14.5	18.9
	750	XFB 900 90 750 F	6	1278	1278	1174	1278	15.3	16.7	21.6
	900	XFB 900 90 900 F	6	1428	1428	1386	1428	16.2	17.8	23.2

Dimensions

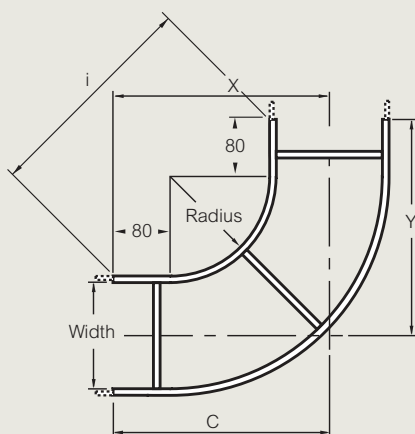

Note
Rungs are shown for illustrative purposes only

Weights

All weights given are in kilograms (kg) and are for hot dip galvanised G finish.

To obtain the appropriate component weight in other finishes, multiply the given weight by the following factors :

- Deep galvanised (D) x 1.07
- Stainless steel (S) x 0.94
- Powder coated (E) x 0.97

■ Rung details

Type 1 rungs are used as standard

Type 2 and 3 are only available to special order, see p. 37
Type 1 can be supplied in any combination to special order

Type 1 standard

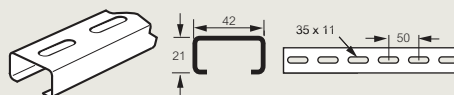

Key : Replace the letter shown in red with your choice from the following options :

- X = Ladder type : Z (Topaz), P (Sapphire), E (Emerald)
- F = Finish : G (hot dip galvanised after manufacture)
D (deep galvanised)
S (stainless steel)
E (powder coated)

→ Integral fitting coupler detail : see p. 44

→ Fitting to fitting coupler sets : see p. 45

Swifts® 60° flat bends

medium duty (Topaz), heavy duty (Sapphire) and extra heavy duty (Emerald)

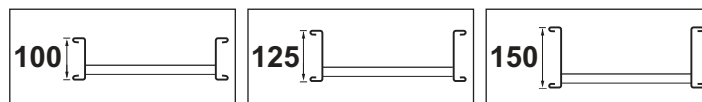

■ Dimensions and weights

Width (W)	Radius (R)	Cat. Nos.	No. of rungs	Dimensions (mm)				Weight (kg)		
				X	Y	i	C	Topaz	Sapphire	Emerald
150	300	XFB 150 60 300 F	2	443	256	439	296	2.8	3.3	4.9
	450	XFB 150 60 450 F	3	573	331	589	382	3.6	4.1	6.1
	600	XFB 150 60 600 F	3	703	406	739	469	4.2	4.9	7.1
	750	XFB 150 60 750 F	3	833	481	889	555	4.8	5.6	8.2
	900	XFB 150 60 900 F	3	963	556	1039	642	5.5	6.3	9.3
300	300	XFB 300 60 300 F	3	508	294	439	339	3.6	4.1	5.9
	450	XFB 300 60 450 F	3	638	369	589	426	4.2	4.9	7.0
	600	XFB 300 60 600 F	3	768	444	739	512	4.9	5.6	8.0
	750	XFB 300 60 750 F	3	898	519	889	599	5.5	6.3	9.1
	900	XFB 300 60 900 F	4	1028	594	1039	685	6.4	7.3	10.4
450	300	XFB 450 60 300 F	3	573	331	439	382	4.3	4.9	6.8
	450	XFB 450 60 450 F	3	703	406	589	469	4.9	5.6	7.9
	600	XFB 450 60 600 F	3	833	481	739	555	5.6	6.3	8.9
	750	XFB 450 60 750 F	4	963	556	889	642	6.6	7.4	10.4
	900	XFB 450 60 900 F	4	1093	631	1039	728	7.2	8.2	11.5
600	300	XFB 600 60 300 F	3	638	368	439	426	5.3	5.9	8.0
	450	XFB 600 60 450 F	3	768	443	589	512	5.9	6.7	9.1
	600	XFB 600 60 600 F	4	898	518	739	599	7.1	8.0	10.8
	750	XFB 600 60 750 F	4	1028	593	889	685	7.8	8.7	11.8
	900	XFB 600 60 900 F	4	1158	668	1039	772	8.4	9.4	12.9
750	300	XFB 750 60 300 F	3	703	406	439	469	6.6	7.3	9.6
	450	XFB 750 60 450 F	4	833	481	589	555	8.2	9.0	11.6
	600	XFB 750 60 600 F	4	963	556	739	642	8.8	9.7	12.7
	750	XFB 750 60 750 F	4	1093	631	889	729	9.5	10.4	13.8
	900	XFB 750 60 900 F	4	1222	706	1039	815	10.1	11.2	14.8
900	300	XFB 900 60 300 F	4	768	443	439	512	8.6	9.4	11.8
	450	XFB 900 60 450 F	4	898	518	589	598	9.3	10.1	12.9
	600	XFB 900 60 600 F	4	1028	593	739	685	9.9	10.8	14.0
	750	XFB 900 60 750 F	4	1157	668	889	772	10.5	11.6	15.0
	900	XFB 900 60 900 F	5	1287	743	1039	858	12.3	13.4	17.3

Dimensions

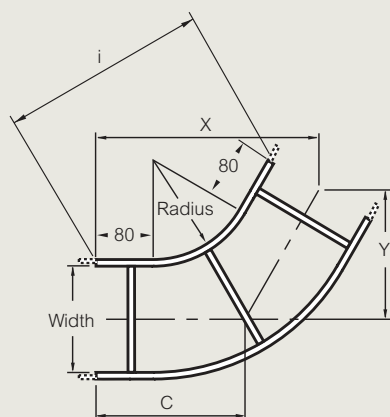

Note
Rungs are shown for illustrative purposes only

Weights

All weights given are in kilograms (kg) and are for hot dip galvanised G finish
To obtain the appropriate component weight in other finishes, multiply the given weight by the following factors :

Deep galvanised (D) x 1.07
Stainless steel (S) x 0.94
Powder coated (E) x 0.97

■ Rung details

Type 1 rungs are used as standard

Type 2 and 3 are only available to special order, see p. 37
Type 1 can be supplied in any combination to special order

Type 1 standard

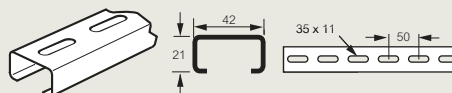

Key : Replace the letter shown in red with your choice from the following options :

X = Ladder type : Z (Topaz), P (Sapphire), E (Emerald)
F = Finish : G (hot dip galvanised after manufacture)
D (deep galvanised)
S (stainless steel)
E (powder coated)

→ Integral fitting coupler detail : see p. 44

→ Fitting to fitting coupler sets : see p. 45

Swifts® 45° flat bends

medium duty (Topaz), heavy duty (Sapphire) and extra heavy duty (Emerald)

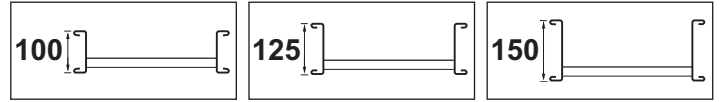

■ Dimensions and weights

Width (W)	Radius (R)	Cat. Nos.	No. of rungs	Dimensions (mm)				Weight (kg)		
				X	Y	i	C	Topaz	Sapphire	Emerald
150	300	XFB 150 45 300 F	2	400	166	377	235	2.4	2.8	4.2
	450	XFB 150 45 450 F	2	506	210	492	297	2.9	3.4	5.0
	600	XFB 150 45 600 F	2	612	254	607	359	3.4	3.9	5.8
	750	XFB 150 45 750 F	3	719	298	722	421	4.0	4.6	6.7
	900	XFB 150 45 900 F	3	825	342	837	483	4.4	5.1	7.5
300	300	XFB 300 45 300 F	2	453	188	377	266	2.9	3.4	4.8
	450	XFB 300 45 450 F	2	559	232	492	328	3.4	3.9	5.6
	600	XFB 300 45 600 F	3	665	276	607	390	4.1	4.7	6.7
	750	XFB 300 45 750 F	3	772	320	722	452	4.6	5.2	7.5
	900	XFB 300 45 900 F	3	878	364	837	514	5.0	5.8	8.3
450	300	XFB 450 45 300 F	2	506	210	377	297	3.4	3.9	5.5
	450	XFB 450 45 450 F	3	612	254	492	359	4.2	4.8	6.7
	600	XFB 450 45 600 F	3	719	298	607	421	4.7	5.3	7.5
	750	XFB 450 45 750 F	3	825	342	722	483	5.2	5.9	8.3
	900	XFB 450 45 900 F	3	931	385	837	545	5.6	6.4	9.1
600	300	XFB 600 45 300 F	3	559	232	377	328	4.7	5.2	6.9
	450	XFB 600 45 450 F	3	665	276	492	390	5.1	5.7	7.7
	600	XFB 600 45 600 F	3	772	320	607	452	5.6	6.3	8.6
	750	XFB 600 45 750 F	3	878	364	722	514	6.1	6.8	9.4
	900	XFB 600 45 900 F	3	984	407	837	576	6.6	7.4	10.2
750	300	XFB 750 45 300 F	3	612	254	377	359	5.9	6.5	8.4
	450	XFB 750 45 450 F	3	719	298	492	421	6.4	7.0	9.2
	600	XFB 750 45 600 F	3	825	342	607	483	6.9	7.6	10.0
	750	XFB 750 45 750 F	3	931	385	722	545	7.4	8.1	10.8
	900	XFB 750 45 900 F	4	1037	429	837	607	8.8	9.6	12.5
900	300	XFB 900 45 300 F	3	665	276	377	390	6.7	7.3	9.3
	450	XFB 900 45 450 F	3	772	320	492	452	7.2	7.9	10.1
	600	XFB 900 45 600 F	3	878	364	607	514	7.7	8.4	11.0
	750	XFB 900 45 750 F	4	984	407	722	576	9.3	10.1	12.9
	900	XFB 900 45 900 F	4	1090	451	837	638	9.7	10.6	13.7

Dimensions

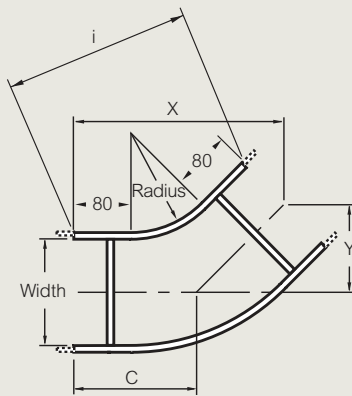

Note
Rungs are shown for illustrative purposes only

- X = length of fitting from each 'end' of centre-line (not including integral coupler)
- Y = length from each 'end' of the fitting to the point at which the centre-lines intersect (not including integral coupler)
- i = measurement across the inner curve of the fitting
- C = length of the centre-line from each 'end' of the fitting to the point at which the centre-lines intersect (not including integral coupler)

Weights

All weights given are in kilograms (kg) and are for hot dip galvanised G finish
To obtain the appropriate component weight in other finishes, multiply the given weight by the following factors :

- Deep galvanised (D) x 1.07
- Stainless steel (S) x 0.94
- Powder coated (E) x 0.97

■ Rung details

Type 1 rungs are used as standard

Type 2 and 3 are only available to special order, see p. 37
Type 1 can be supplied in any combination to special order

Type 1 standard

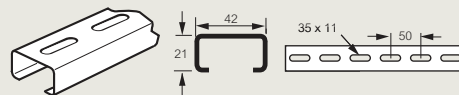

Key : Replace the letter shown in red with your choice from the following options :

- X = Ladder type : Z (Topaz), P (Sapphire), E (Emerald)
- F = Finish : G (hot dip galvanised after manufacture)
D (deep galvanised)
S (stainless steel)
E (powder coated)

→ Integral fitting coupler detail : see p. 44

→ Fitting to fitting coupler sets : see p. 45

Swifts® 30° flat bends

medium duty (Topaz), heavy duty (Sapphire) and extra heavy duty (Emerald)

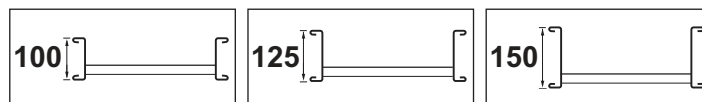

■ Dimensions and weights

Width (W)	Radius (R)	Cat. Nos.	No. of rungs	Dimensions (mm)				Weight (kg)		
				X	Y	i	C	Topaz	Sapphire	Emerald
150	300	XFB 150 30 300 F	2	336	90	310	180	2.0	2.4	3.5
	450	XFB 150 30 450 F	2	411	110	387	220	2.3	2.8	4.0
	600	XFB 150 30 600 F	2	486	130	465	260	2.7	3.1	4.6
	750	XFB 150 30 750 F	2	561	150	543	301	3.0	3.5	5.1
	900	XFB 150 30 900 F	2	636	170	620	341	3.3	3.8	5.7
300	300	XFB 300 30 300 F	2	373	100	310	200	2.4	2.8	4.0
	450	XFB 300 30 450 F	2	448	120	387	240	2.7	3.2	4.6
	600	XFB 300 30 600 F	2	523	140	465	280	3.1	3.5	5.1
	750	XFB 300 30 750 F	2	598	160	543	321	3.4	3.9	5.6
	900	XFB 300 30 900 F	2	673	180	620	361	3.7	4.3	6.2
450	300	XFB 450 30 300 F	2	411	110	310	220	2.8	3.2	4.5
	450	XFB 450 30 450 F	2	486	130	387	260	3.1	3.6	5.1
	600	XFB 450 30 600 F	2	561	150	465	301	3.5	4.0	5.6
	750	XFB 450 30 750 F	2	636	170	543	341	3.8	4.3	6.2
	900	XFB 450 30 900 F	3	711	190	620	381	4.5	5.1	7.1
600	300	XFB 600 30 300 F	2	448	120	310	240	3.4	3.9	5.3
	450	XFB 600 30 450 F	2	523	140	387	281	3.8	4.2	5.8
	600	XFB 600 30 600 F	2	598	160	465	321	4.1	4.6	6.3
	750	XFB 600 30 750 F	3	673	180	543	361	5.0	5.6	7.5
	900	XFB 600 30 900 F	3	748	201	620	401	5.3	5.9	8.0
750	300	XFB 750 30 300 F	2	486	130	310	260	4.3	4.7	6.2
	450	XFB 750 30 450 F	2	561	150	387	301	4.6	5.1	6.8
	600	XFB 750 30 600 F	3	636	170	465	341	5.9	6.4	8.2
	750	XFB 750 30 750 F	3	711	190	543	381	6.2	6.8	8.8
	900	XFB 750 30 900 F	3	786	211	620	421	6.5	7.1	9.3
900	300	XFB 900 30 300 F	2	523	140	310	281	4.8	5.3	6.9
	450	XFB 900 30 450 F	3	598	160	387	321	6.3	6.8	8.5
	600	XFB 900 30 600 F	3	673	180	465	361	6.6	7.2	9.1
	750	XFB 900 30 750 F	3	748	201	543	401	6.9	7.5	9.6
	900	XFB 900 30 900 F	3	823	221	620	441	7.2	7.9	10.1

Dimensions

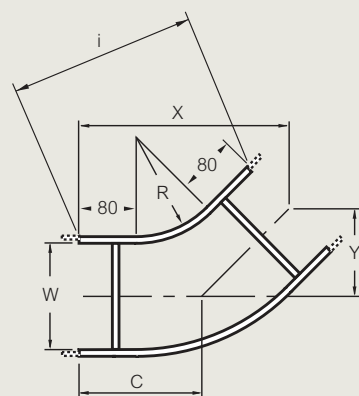

Note
Rungs are shown for illustrative purposes only

- X = length of fitting from each 'end' of centre-line (not including integral coupler)
- Y = length from each 'end' of the fitting to the point at which the centre-lines intersect (not including integral coupler)
- i = measurement across the inner curve of the fitting
- C = length of the centre-line from each 'end' of the fitting to the point at which the centre-lines intersect (not including integral coupler)

Weights

All weights given are in kilograms (kg) and are for hot dip galvanised G finish
To obtain the appropriate component weight in other finishes, multiply the given weight by the following factors :

- Deep galvanised (D) x 1.07
- Stainless steel (S) x 0.94
- Powder coated (E) x 0.97

■ Rung details

Type 1 rungs are used as standard

Type 2 and 3 are only available to special order, see p. 37
Type 1 can be supplied in any combination to special order

Type 1 standard

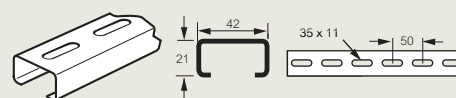

Key : Replace the letter shown in red with your choice from the following options :

- X = Ladder type : Z (Topaz), P (Sapphire), E (Emerald)
- F = Finish : G (hot dip galvanised after manufacture)
D (deep galvanised)
S (stainless steel)
E (powder coated)

→ Integral fitting coupler detail : see p. 44

→ Fitting to fitting coupler sets : see p. 45

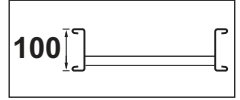

■ Dimensions and weights

Width (W)	Radius (R)	Cat. Nos. ⁽¹⁾	No. of rungs	Dimensions (mm)				Weight (kg)
				X	Y	i	C	
150	300	ZIR 150 90 300 F	3	350	350	424	350	3.1
	450	ZIR 150 90 450 F	3	500	500	636	500	4.1
	600	ZIR 150 90 600 F	4	650	650	849	650	5.1
	750	ZIR 150 90 750 F	4	800	800	1061	800	6.0
	900	ZIR 150 90 900 F	4	950	950	1273	950	7.0
300	300	ZIR 300 90 300 F	3	350	350	424	350	3.5
	450	ZIR 300 90 450 F	3	500	500	636	500	4.5
	600	ZIR 300 90 600 F	4	650	650	849	650	5.6
	750	ZIR 300 90 750 F	4	800	800	1061	800	6.5
	900	ZIR 300 90 900 F	4	950	950	1273	950	7.5
450	300	ZIR 450 90 300 F	3	350	350	424	350	3.8
	450	ZIR 450 90 450 F	3	500	500	636	500	4.8
	600	ZIR 450 90 600 F	4	650	650	849	650	6.0
	750	ZIR 450 90 750 F	4	800	800	1061	800	7.0
	900	ZIR 450 90 900 F	4	950	950	1273	950	8.0
600	300	ZIR 600 90 300 F	3	350	350	424	350	4.5
	450	ZIR 600 90 450 F	3	500	500	636	500	5.5
	600	ZIR 600 90 600 F	4	650	650	849	650	7.0
	750	ZIR 600 90 750 F	4	800	800	1061	800	7.9
	900	ZIR 600 90 900 F	4	950	950	1273	950	8.9
750	300	ZIR 750 90 300 F	3	350	350	424	350	5.5
	450	ZIR 750 90 450 F	3	500	500	636	500	6.5
	600	ZIR 750 90 600 F	4	650	650	849	650	8.3
	750	ZIR 750 90 750 F	4	800	800	1061	800	9.3
	900	ZIR 750 90 900 F	4	950	950	1273	950	10.3
900	300	ZIR 900 90 300 F	3	350	350	424	350	6.1
	450	ZIR 900 90 450 F	3	500	500	636	500	7.1
	600	ZIR 900 90 600 F	4	650	650	849	650	9.1
	750	ZIR 900 90 750 F	4	800	800	1061	800	10.1
	900	ZIR 900 90 900 F	4	950	950	1273	950	11.0

(1) Cat. Nos. given in the table are for inside risers. For outside risers substitute ZIR for ZOR

Dimensions

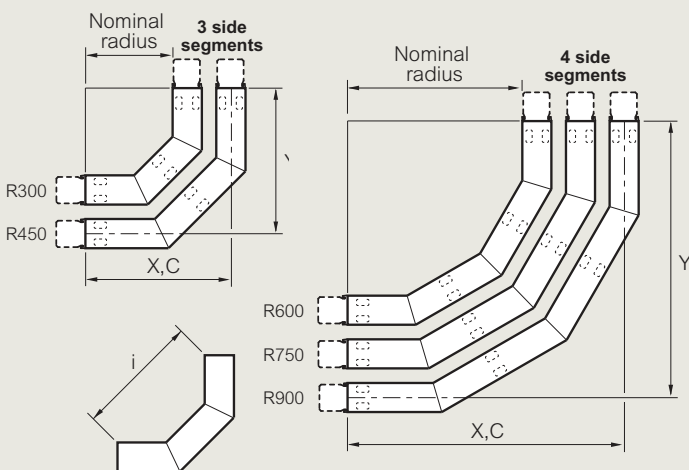

X = length of fitting from each 'end' of centre-line (not including integral coupler)
 Y = length from each 'end' of the fitting to the point at which the centre-lines intersect (not including integral coupler)
 i = measurement across the inner curve of the fitting
 C = length of the centre-line from each 'end' of the fitting to the point at which the centre-lines intersect (not including integral coupler)

All dimensions (mm) are nominal

Weights

All weights given are in kilograms (kg) and are for hot dip galvanised G finish

To obtain the appropriate component weight in other finishes, multiply the given weight by the following factors :

Deep galvanised (D) x 1.07
 Stainless steel (S) x 0.94
 Powder coated (E) x 0.97

■ Rung details

Type 1 rungs are used as standard

Type 2 and 3 are only available to special order, see p. 37
 Type 1 can be supplied in any combination to special order

Type 1 standard

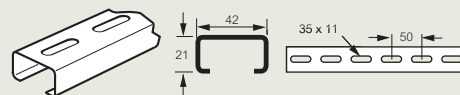

Key : Replace the letter shown in red with your choice from the following options :

F = Finish : G (hot dip galvanised after manufacture)
 D (deep galvanised)
 S (stainless steel)
 E (powder coated)

➔ Integral fitting coupler detail : see p. 44

➔ Fitting to fitting coupler sets : see p. 45

Swifts® 90° inside and outside risers

heavy duty (Sapphire)

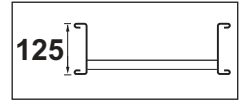

■ Dimensions and weights

Width (W)	Radius (R)	Cat. Nos. ⁽¹⁾	No. of rungs	Dimensions (mm)				Weight (kg)
				X	Y	i	C	
150	300	PIR 150 90 300 F	3	363	363	424	363	3.7
	450	PIR 150 90 450 F	3	513	513	636	513	4.9
	600	PIR 150 90 600 F	4	663	663	849	663	6.0
	750	PIR 150 90 750 F	4	813	813	1061	813	7.1
	900	PIR 150 90 900 F	4	963	963	1273	963	8.2
300	300	PIR 300 90 300 F	3	363	363	424	363	4.1
	450	PIR 300 90 450 F	3	513	513	636	513	5.2
	600	PIR 300 90 600 F	4	663	663	849	663	6.5
	750	PIR 300 90 750 F	4	813	813	1061	813	7.6
	900	PIR 300 90 900 F	4	963	963	1273	963	8.7
450	300	PIR 450 90 300 F	3	363	363	424	363	4.4
	450	PIR 450 90 450 F	3	513	513	636	513	5.6
	600	PIR 450 90 600 F	4	663	663	849	663	6.9
	750	PIR 450 90 750 F	4	813	813	1061	813	8.1
	900	PIR 450 90 900 F	4	963	963	1273	963	9.2
600	300	PIR 600 90 300 F	3	363	363	424	363	5.1
	450	PIR 600 90 450 F	3	513	513	636	513	6.3
	600	PIR 600 90 600 F	4	663	663	849	663	7.9
	750	PIR 600 90 750 F	4	813	813	1061	813	9.0
	900	PIR 600 90 900 F	4	963	963	1273	963	10.1
750	300	PIR 750 90 300 F	3	363	363	424	363	6.1
	450	PIR 750 90 450 F	3	513	513	636	513	7.3
	600	PIR 750 90 600 F	4	663	663	849	663	9.2
	750	PIR 750 90 750 F	4	813	813	1061	813	10.3
	900	PIR 750 90 900 F	4	963	963	1273	963	11.5
900	300	PIR 900 90 300 F	3	363	363	424	363	6.7
	450	PIR 900 90 450 F	3	513	513	636	513	7.9
	600	PIR 900 90 600 F	4	663	663	849	663	10.0
	750	PIR 900 90 750 F	4	813	813	1061	813	11.1
	900	PIR 900 90 900 F	4	963	963	1273	963	12.2

(1) Cat. Nos. given in the table are for inside risers. For outside risers substitute PIR for POR

Dimensions

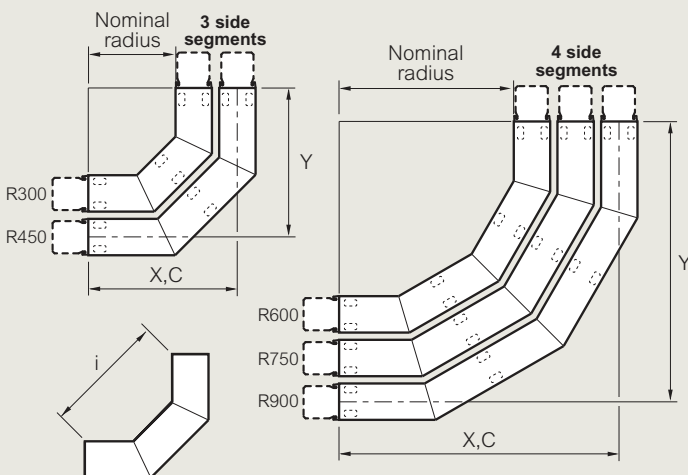

- X = length of fitting from each 'end' of centre-line (not including integral coupler)
- Y = length from each 'end' of the fitting to the point at which the centre-lines intersect (not including integral coupler)
- i = measurement across the inner curve of the fitting
- C = length of the centre-line from each 'end' of the fitting to the point at which the centre-lines intersect (not including integral coupler)

All dimensions (mm) are nominal

Weights

All weights given are in kilograms (kg) and are for hot dip galvanised G finish

To obtain the appropriate component weight in other finishes, multiply the given weight by the following factors :

- Deep galvanised (D) x 1.07
- Stainless steel (S) x 0.94
- Powder coated (E) x 0.97

■ Rung details

Type 1 rungs are used as standard

Type 2 and 3 are only available to special order, see p. 37
Type 1 can be supplied in any combination to special order

Type 1 standard

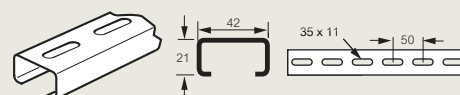

Key : Replace the letter shown in red with your choice from the following options :

- F = Finish : G (hot dip galvanised after manufacture)
- D (deep galvanised)
- S (stainless steel)
- E (powder coated)

➔ Integral fitting coupler detail : see p. 44

➔ Fitting to fitting coupler sets : see p. 45

Swifts® 90° inside and outside risers extra heavy duty (Emerald)

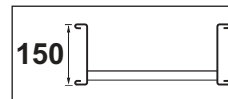

■ Dimensions and weights

Width (W)	Radius (R)	Cat. Nos. ⁽¹⁾	No. of rungs	Dimensions (mm)				Weight (kg)
				X	Y	i	C	
150	300	EIR 150 90 300 F	3	375	375	424	375	5.5
	450	EIR 150 90 450 F	3	525	525	636	525	7.2
	600	EIR 150 90 600 F	4	675	675	849	675	8.8
	750	EIR 150 90 750 F	4	825	825	1061	825	10.5
	900	EIR 150 90 900 F	4	975	975	1273	975	12.2
300	300	EIR 300 90 300 F	3	375	375	424	375	5.9
	450	EIR 300 90 450 F	3	525	525	636	525	7.6
	600	EIR 300 90 600 F	4	675	675	849	675	9.3
	750	EIR 300 90 750 F	4	825	825	1061	825	11.0
	900	EIR 300 90 900 F	4	975	975	1273	975	12.6
450	300	EIR 450 90 300 F	3	375	375	424	375	6.3
	450	EIR 450 90 450 F	3	525	525	636	525	8.0
	600	EIR 450 90 600 F	4	675	675	849	675	9.8
	750	EIR 450 90 750 F	4	825	825	1061	825	11.5
	900	EIR 450 90 900 F	4	975	975	1273	975	13.1
600	300	EIR 600 90 300 F	3	375	375	424	375	6.9
	450	EIR 600 90 450 F	3	525	525	636	525	8.7
	600	EIR 600 90 600 F	4	675	675	849	675	10.7
	750	EIR 600 90 750 F	4	825	825	1061	825	12.4
	900	EIR 600 90 900 F	4	975	975	1273	975	14.0
750	300	EIR 750 90 300 F	3	375	375	424	375	8.0
	450	EIR 750 90 450 F	3	525	525	636	525	9.7
	600	EIR 750 90 600 F	4	675	675	849	675	12.1
	750	EIR 750 90 750 F	4	825	825	1061	825	13.7
	900	EIR 750 90 900 F	4	975	975	1273	975	15.4
900	300	EIR 900 90 300 F	3	375	375	424	375	8.5
	450	EIR 900 90 450 F	3	525	525	636	525	10.2
	600	EIR 900 90 600 F	4	675	675	849	675	12.8
	750	EIR 900 90 750 F	4	825	825	1061	825	14.5
	900	EIR 900 90 900 F	4	975	975	1273	975	16.2

(1) Cat. Nos. given in the table are for inside risers. For outside risers substitute EIR for EOR

Dimensions

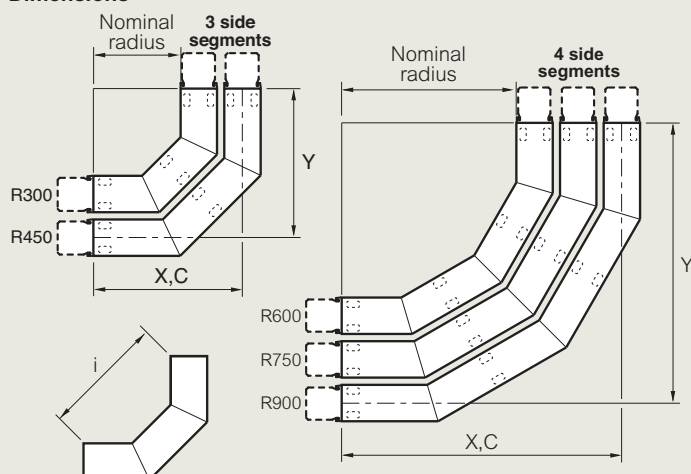

X = length of fitting from each 'end' of centre-line (not including integral coupler)
 Y = length from each 'end' of the fitting to the point at which the centre-lines intersect (not including integral coupler)
 i = measurement across the inner curve of the fitting
 C = length of the centre-line from each 'end' of the fitting to the point at which the centre-lines intersect (not including integral coupler)

All dimensions (mm) are nominal

Weights

All weights given are in kilograms (kg) and are for hot dip galvanised G finish

To obtain the appropriate component weight in other finishes, multiply the given weight by the following factors :

Deep galvanised (D) x 1.07
 Stainless steel (S) x 0.94
 Powder coated (E) x 0.97

■ Rung details

Type 1 rungs are used as standard

Type 2 and 3 are only available to special order, see p. 37
 Type 1 can be supplied in any combination to special order

Type 1 standard

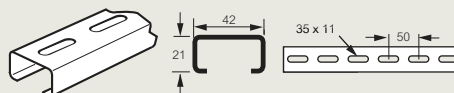

Key : Replace the letter shown in red with your choice from the following options :

F = Finish : **G** (hot dip galvanised after manufacture)
D (deep galvanised)
S (stainless steel)
E (powder coated)

➔ Integral fitting coupler detail : see p. 44

➔ Fitting to fitting coupler sets : see p. 45

Swifts® 60° inside and outside risers medium duty (Topaz)

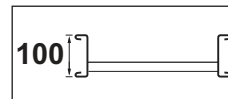

■ Dimensions and weights

Width (W)	Radius (R)	Cat. Nos. ⁽¹⁾	No. of rungs	Dimensions (mm)				Weight (kg)
				X	Y	i	c	
150	300	ZIR 150 60 300 F	3	303	175	300	202	2.2
	450	ZIR 150 60 450 F	3	433	250	450	289	2.9
	600	ZIR 150 60 600 F	3	563	325	600	375	3.5
	750	ZIR 150 60 750 F	3	693	400	750	462	4.2
	900	ZIR 150 60 900 F	3	823	475	900	548	4.8
300	300	ZIR 300 60 300 F	3	303	175	300	202	2.6
	450	ZIR 300 60 450 F	3	433	250	450	289	3.2
	600	ZIR 300 60 600 F	3	563	325	600	375	3.9
	750	ZIR 300 60 750 F	3	693	400	750	462	4.5
	900	ZIR 300 60 900 F	3	823	475	900	548	5.2
450	300	ZIR 450 60 300 F	3	303	175	300	202	3.0
	450	ZIR 450 60 450 F	3	433	250	450	289	3.6
	600	ZIR 450 60 600 F	3	563	325	600	375	4.3
	750	ZIR 450 60 750 F	3	693	400	750	462	4.9
	900	ZIR 450 60 900 F	3	823	475	900	548	5.5
600	300	ZIR 600 60 300 F	3	303	175	300	202	3.6
	450	ZIR 600 60 450 F	3	433	250	450	289	4.3
	600	ZIR 600 60 600 F	3	563	325	600	375	4.9
	750	ZIR 600 60 750 F	3	693	400	750	462	5.6
	900	ZIR 600 60 900 F	3	823	475	900	548	6.2
750	300	ZIR 750 60 300 F	3	303	175	300	202	4.7
	450	ZIR 750 60 450 F	3	433	250	450	289	5.3
	600	ZIR 750 60 600 F	3	563	325	600	375	6.0
	750	ZIR 750 60 750 F	3	693	400	750	462	6.6
	900	ZIR 750 60 900 F	3	823	475	900	548	7.3
900	300	ZIR 900 60 300 F	3	303	175	300	202	5.2
	450	ZIR 900 60 450 F	3	433	250	450	289	5.9
	600	ZIR 900 60 600 F	3	563	325	600	375	6.5
	750	ZIR 900 60 750 F	3	693	400	750	462	7.2
	900	ZIR 900 60 900 F	3	823	475	900	548	7.8

(1) Cat. Nos. given in the table are for inside risers. For outside risers substitute ZIR for ZOR

Dimensions

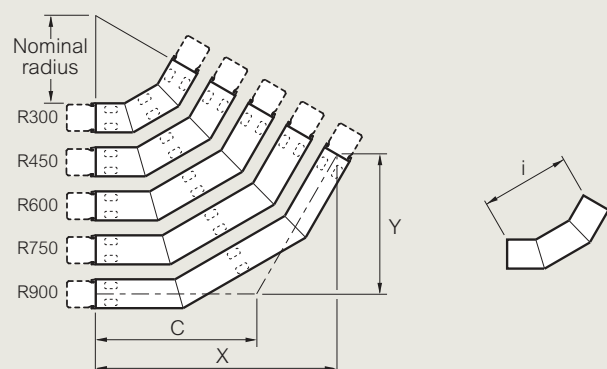

X = length of fitting from each 'end' of centre-line (not including integral coupler)

Y = length from each 'end' of the fitting to the point at which the centre-lines intersect (not including integral coupler)

i = measurement across the inner curve of the fitting

C = length of the centre-line from each 'end' of the fitting to the point at which the centre-lines intersect (not including integral coupler)

Weights

All weights given are in kilograms (kg) and are for hot dip galvanised G finish

To obtain the appropriate component weight in other finishes, multiply the given weight by the following factors :

Deep galvanised (D) x 1.07
Stainless steel (S) x 0.94
Powder coated (E) x 0.97

■ Rung details

Type 1 rungs are used as standard

Type 2 and 3 are only available to special order, see p. 37

Type 1 can be supplied in any combination to special order

Type 1 standard

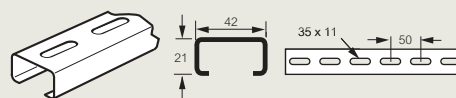

Key : Replace the letter shown in red with your choice from the following options :

F = Finish : G (hot dip galvanised after manufacture)
D (deep galvanised)
S (stainless steel)
E (powder coated)

→ Integral fitting coupler detail : see p. 44

→ Fitting to fitting coupler sets : see p. 45

All dimensions (mm) are nominal

Swifts® 60° inside and outside risers

heavy duty (Sapphire)

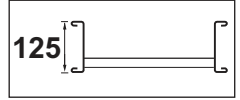

■ Dimensions and weights

Width (W)	Radius (R)	Cat. Nos. ⁽¹⁾	No. of rungs	Dimensions (mm)				Weight (kg)
				X	Y	i	C	
150	300	PIR 150 60 300 F	3	314	181	300	209	2.7
	450	PIR 150 60 450 F	3	444	256	450	296	3.4
	600	PIR 150 60 600 F	3	574	331	600	382	4.2
	750	PIR 150 60 750 F	3	704	406	750	469	4.9
	900	PIR 150 60 900 F	3	834	481	900	556	5.7
300	300	PIR 300 60 300 F	3	314	181	300	209	3.0
	450	PIR 300 60 450 F	3	444	256	450	296	3.8
	600	PIR 300 60 600 F	3	574	331	600	382	4.5
	750	PIR 300 60 750 F	3	704	406	750	469	5.3
	900	PIR 300 60 900 F	3	834	481	900	556	6.0
450	300	PIR 450 60 300 F	3	314	181	300	209	3.4
	450	PIR 450 60 450 F	3	444	256	450	296	4.1
	600	PIR 450 60 600 F	3	574	331	600	382	4.9
	750	PIR 450 60 750 F	3	704	406	750	469	5.6
	900	PIR 450 60 900 F	3	834	481	900	556	6.4
600	300	PIR 600 60 300 F	3	314	181	300	209	4.1
	450	PIR 600 60 450 F	3	444	256	450	296	4.8
	600	PIR 600 60 600 F	3	574	331	600	382	5.6
	750	PIR 600 60 750 F	3	704	406	750	469	6.3
	900	PIR 600 60 900 F	3	834	481	900	556	7.1
750	300	PIR 750 60 300 F	3	314	181	300	209	5.1
	450	PIR 750 60 450 F	3	444	256	450	296	5.9
	600	PIR 750 60 600 F	3	574	331	600	382	6.6
	750	PIR 750 60 750 F	3	704	406	750	469	7.3
	900	PIR 750 60 900 F	3	834	481	900	556	8.1
900	300	PIR 900 60 300 F	3	314	181	300	209	5.7
	450	PIR 900 60 450 F	3	444	256	450	296	6.4
	600	PIR 900 60 600 F	3	574	331	600	382	7.2
	750	PIR 900 60 750 F	3	704	406	750	469	7.9
	900	PIR 900 60 900 F	3	834	481	900	556	8.7

(1) Cat. Nos. given in the table are for inside risers. For outside risers substitute PIR for POR

Dimensions

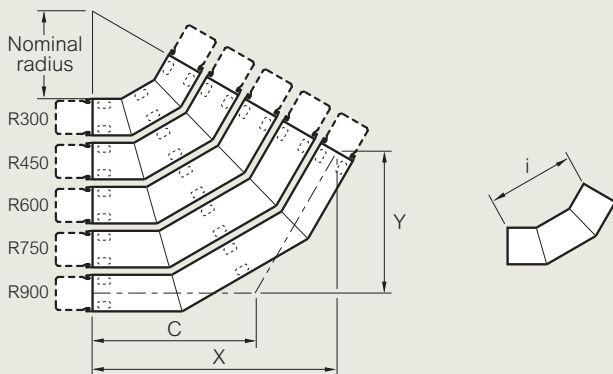

X = length of fitting from each 'end' of centre-line (not including integral coupler)

Y = length from each 'end' of the fitting to the point at which the centre-lines intersect (not including integral coupler)

i = measurement across the inner curve of the fitting

C = length of the centre-line from each 'end' of the fitting to the point at which the centre-lines intersect (not including integral coupler)

Weights

All weights given are in kilograms (kg) and are for hot dip galvanised G finish

To obtain the appropriate component weight in other finishes, multiply the given weight by the following factors :

- Deep galvanised (D) x 1.07
- Stainless steel (S) x 0.94
- Powder coated (E) x 0.97

■ Rung details

Type 1 rungs are used as standard

Type 2 and 3 are only available to special order, see p. 37

Type 1 can be supplied in any combination to special order

Type 1 standard

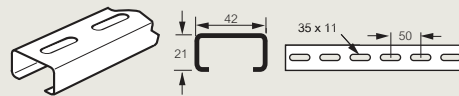

Key : Replace the letter shown in red with your choice from the following options :

- F = Finish : G (hot dip galvanised after manufacture)
- D (deep galvanised)
- S (stainless steel)
- E (powder coated)

→ Integral fitting coupler detail : see p. 44

→ Fitting to fitting coupler sets : see p. 45

All dimensions (mm) are nominal

Swifts® 60° inside and outside risers

extra heavy duty (Emerald)

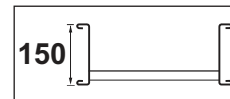

■ Dimensions and weights

Width (W)	Radius (R)	Cat. Nos. ⁽¹⁾	No. of rungs	Dimensions (mm)				Weight (kg)
				X	Y	i	C	
150	300	EIR 150 60 300 F	3	325	187	300	217	3.9
	450	EIR 150 60 450 F	3	455	262	450	303	5.1
	600	EIR 150 60 600 F	4	585	337	600	390	6.2
	750	EIR 150 60 750 F	4	714	412	750	476	7.3
	900	EIR 150 60 900 F	4	844	487	900	563	8.4
300	300	EIR 300 60 300 F	3	325	187	300	217	4.3
	450	EIR 300 60 450 F	3	455	262	450	303	5.4
	600	EIR 300 60 600 F	4	585	337	600	390	6.5
	750	EIR 300 60 750 F	4	714	412	750	476	7.6
	900	EIR 300 60 900 F	4	844	487	900	563	8.7
450	300	EIR 450 60 300 F	3	325	187	300	217	4.7
	450	EIR 450 60 450 F	3	455	262	450	303	5.8
	600	EIR 450 60 600 F	4	585	337	600	390	6.9
	750	EIR 450 60 750 F	4	714	412	750	476	8.0
	900	EIR 450 60 900 F	4	844	487	900	563	9.1
600	300	EIR 600 60 300 F	3	325	187	300	217	5.4
	450	EIR 600 60 450 F	3	455	262	450	303	6.5
	600	EIR 600 60 600 F	4	585	337	600	390	7.6
	750	EIR 600 60 750 F	4	714	412	750	476	8.7
	900	EIR 600 60 900 F	4	844	487	900	563	9.8
750	300	EIR 750 60 300 F	3	325	187	300	217	6.4
	450	EIR 750 60 450 F	3	455	262	450	303	7.5
	600	EIR 750 60 600 F	4	585	337	600	390	8.6
	750	EIR 750 60 750 F	4	714	412	750	476	9.7
	900	EIR 750 60 900 F	4	844	487	900	563	10.8
900	300	EIR 900 60 300 F	3	325	187	300	217	7.0
	450	EIR 900 60 450 F	3	455	262	450	303	8.1
	600	EIR 900 60 600 F	4	585	337	600	390	9.2
	750	EIR 900 60 750 F	4	714	412	750	476	10.3
	900	EIR 900 60 900 F	4	844	487	900	563	11.4

(1) Cat. Nos. given in the table are for inside risers. For outside risers substitute EIR for EOR

Dimensions

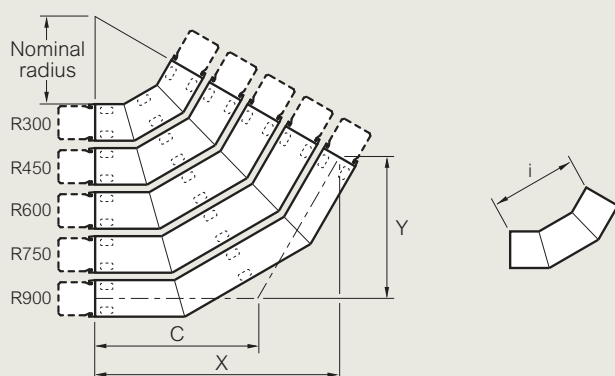

X = length of fitting from each 'end' of centre-line (not including integral coupler)

Y = length from each 'end' of the fitting to the point at which the centre-lines intersect (not including integral coupler)

i = measurement across the inner curve of the fitting

C = length of the centre-line from each 'end' of the fitting to the point at which the centre-lines intersect (not including integral coupler)

Weights

All weights given are in kilograms (kg) and are for hot dip galvanised G finish

To obtain the appropriate component weight in other finishes, multiply the given weight by the following factors :

Deep galvanised (D) x 1.07
 Stainless steel (S) x 0.94
 Powder coated (E) x 0.97

■ Rung details

Type 1 rungs are used as standard

Type 2 and 3 are only available to special order, see p. 37

Type 1 can be supplied in any combination to special order

Type 1 standard

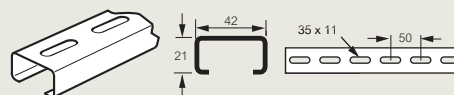

Key : Replace the letter shown in red with your choice from the following options :

F = Finish : G (hot dip galvanised after manufacture)
 D (deep galvanised)
 S (stainless steel)
 E (powder coated)

→ Integral fitting coupler detail : see p. 44

→ Fitting to fitting coupler sets : see p. 45

All dimensions (mm) are nominal

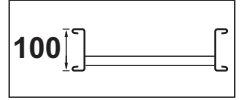

■ Dimensions and weights

Width (W)	Radius (R)	Cat. Nos. ⁽¹⁾	No. of rungs	Dimensions (mm)				Weight (kg)
				X	Y	i	C	
150	300	ZIR 150 45 300 F	2	247	103	230	145	1.8
	450	ZIR 150 45 450 F	2	354	146	344	207	2.3
	600	ZIR 150 45 600 F	3	460	190	459	269	2.8
	750	ZIR 150 45 750 F	3	566	234	574	331	3.3
	900	ZIR 150 45 900 F	3	672	278	689	394	3.8
300	300	ZIR 300 45 300 F	2	247	103	230	145	2.0
	450	ZIR 300 45 450 F	2	354	146	344	207	2.5
	600	ZIR 300 45 600 F	3	460	190	459	269	3.2
	750	ZIR 300 45 750 F	3	566	234	574	331	3.6
	900	ZIR 300 45 900 F	3	672	278	689	394	4.1
450	300	ZIR 450 45 300 F	2	247	103	230	145	2.2
	450	ZIR 450 45 450 F	2	354	146	344	207	2.7
	600	ZIR 450 45 600 F	3	460	190	459	269	3.5
	750	ZIR 450 45 750 F	3	566	234	574	331	4.0
	900	ZIR 450 45 900 F	3	672	278	689	394	4.5
600	300	ZIR 600 45 300 F	2	247	103	230	145	2.7
	450	ZIR 600 45 450 F	2	354	146	344	207	3.2
	600	ZIR 600 45 600 F	3	460	190	459	269	4.2
	750	ZIR 600 45 750 F	3	566	234	574	331	4.7
	900	ZIR 600 45 900 F	3	672	278	689	394	5.2
750	300	ZIR 750 45 300 F	2	247	103	230	145	3.4
	450	ZIR 750 45 450 F	2	354	146	344	207	3.9
	600	ZIR 750 45 600 F	3	460	190	459	269	5.2
	750	ZIR 750 45 750 F	3	566	234	574	331	5.7
	900	ZIR 750 45 900 F	3	672	278	689	394	6.2
900	300	ZIR 900 45 300 F	2	247	103	230	145	3.8
	450	ZIR 900 45 450 F	2	354	146	344	207	4.3
	600	ZIR 900 45 600 F	3	460	190	459	269	5.8
	750	ZIR 900 45 750 F	3	566	234	574	331	6.3
	900	ZIR 900 45 900 F	3	672	278	689	394	6.8

(1) Cat. Nos. given in the table are for inside risers. For outside risers substitute ZIR for ZOR

Dimensions

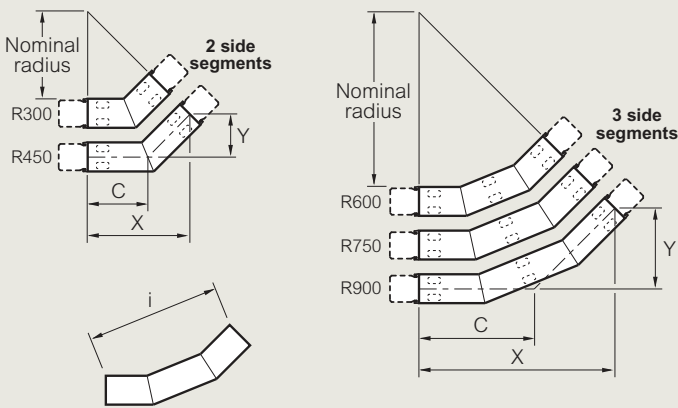

- X = length of fitting from each 'end' of centre-line (not including integral coupler)
- Y = length from each 'end' of the fitting to the point at which the centre-lines intersect (not including integral coupler)
- i = measurement across the inner curve of the fitting
- C = length of the centre-line from each 'end' of the fitting to the point at which the centre-lines intersect (not including integral coupler)

Weights

All weights given are in kilograms (kg) and are for hot dip galvanised G finish

To obtain the appropriate component weight in other finishes, multiply the given weight by the following factors :

- Deep galvanised (D) x 1.07
- Stainless steel (S) x 0.94
- Powder coated (E) x 0.97

■ Rung details

Type 1 rungs are used as standard

Type 2 and 3 are only available to special order, see p. 37
Type 1 can be supplied in any combination to special order

Type 1 standard

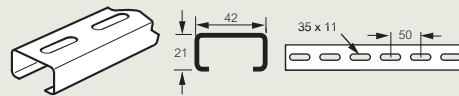

Key : Replace the letter shown in red with your choice from the following options :

- F = Finish : G (hot dip galvanised after manufacture)
- D (deep galvanised)
- S (stainless steel)
- E (powder coated)

➔ Integral fitting coupler detail : see p. 44

➔ Fitting to fitting coupler sets : see p. 45

Swifts® 45° inside and outside risers

heavy duty (Sapphire)

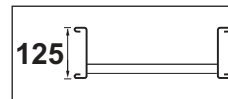

■ Dimensions and weights

Width (W)	Radius (R)	Cat. Nos. ⁽¹⁾	No. of rungs	Dimensions (mm)				Weight (kg)
				X	Y	i	C	
150	300	PIR 150 45 300 F	2	256	106	230	150	2.1
	450	PIR 150 45 450 F	2	362	150	344	212	2.7
	600	PIR 150 45 600 F	3	468	194	459	274	3.3
	750	PIR 150 45 750 F	3	575	238	574	337	3.9
	900	PIR 150 45 900 F	3	681	282	689	399	4.4
300	300	PIR 300 45 300 F	2	256	106	230	150	2.4
	450	PIR 300 45 450 F	2	362	150	344	212	2.9
	600	PIR 300 45 600 F	3	468	194	459	274	3.7
	750	PIR 300 45 750 F	3	575	238	574	337	4.2
	900	PIR 300 45 900 F	3	681	282	689	399	4.8
450	300	PIR 450 45 300 F	2	256	106	230	150	2.6
	450	PIR 450 45 450 F	2	362	150	344	212	3.2
	600	PIR 450 45 600 F	3	468	194	459	274	4.0
	750	PIR 450 45 750 F	3	575	238	574	337	4.6
	900	PIR 450 45 900 F	3	681	282	689	399	5.1
600	300	PIR 600 45 300 F	2	256	106	230	150	3.1
	450	PIR 600 45 450 F	2	362	150	344	212	3.6
	600	PIR 600 45 600 F	3	468	194	459	274	4.7
	750	PIR 600 45 750 F	3	575	238	574	337	5.3
	900	PIR 600 45 900 F	3	681	282	689	399	5.8
750	300	PIR 750 45 300 F	2	256	106	230	150	3.8
	450	PIR 750 45 450 F	2	362	150	344	212	4.3
	600	PIR 750 45 600 F	3	468	194	459	274	5.7
	750	PIR 750 45 750 F	3	575	238	574	337	6.3
	900	PIR 750 45 900 F	3	681	282	689	399	6.9
900	300	PIR 900 45 300 F	2	256	106	230	150	4.1
	450	PIR 900 45 450 F	2	362	150	344	212	4.7
	600	PIR 900 45 600 F	3	468	194	459	274	6.3
	750	PIR 900 45 750 F	3	575	238	574	337	6.9
	900	PIR 900 45 900 F	3	681	282	689	399	7.4

(1) Cat. Nos. given in the table are for inside risers. For outside risers substitute PIR for POR

Dimensions

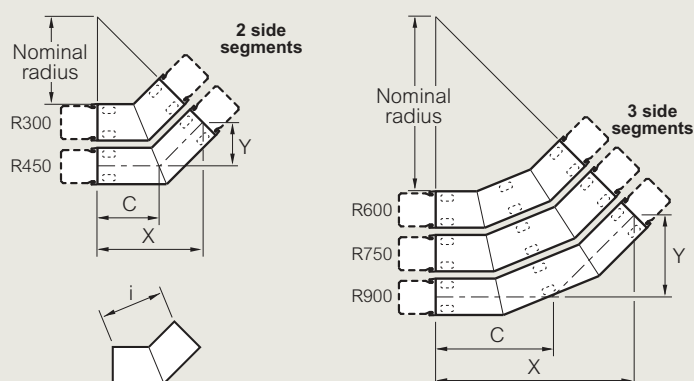

X = length of fitting from each 'end' of centre-line (not including integral coupler)
 Y = length from each 'end' of the fitting to the point at which the centre-lines intersect (not including integral coupler)
 i = measurement across the inner curve of the fitting
 C = length of the centre-line from each 'end' of the fitting to the point at which the centre-lines intersect (not including integral coupler)

Weights

All weights given are in kilograms (kg) and are for hot dip galvanised G finish
 To obtain the appropriate component weight in other finishes, multiply the given weight by the following factors :

Deep galvanised (D) x 1.07
 Stainless steel (S) x 0.94
 Powder coated (E) x 0.97

■ Rung details

Type 1 rungs are used as standard

Type 2 and 3 are only available to special order, see p. 37
 Type 1 can be supplied in any combination to special order

Type 1 standard

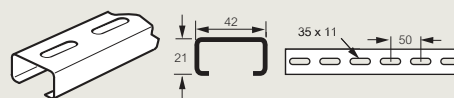

Key : Replace the letter shown in red with your choice from the following options :

F = Finish : **G** (hot dip galvanised after manufacture)
D (deep galvanised)
S (stainless steel)
E (powder coated)

➔ Integral fitting coupler detail : see p. 44

➔ Fitting to fitting coupler sets : see p. 45

All dimensions (mm) are nominal

Swifts® 45° inside and outside risers extra heavy duty (Emerald)

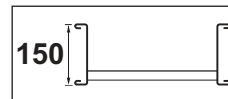

■ Dimensions and weights

Width (W)	Radius (R)	Cat. Nos. ⁽¹⁾	No. of rungs	Dimensions (mm)				Weight (kg)
				X	Y	i	C	
150	300	EIR 150 45 300 F	2	265	110	230	155	3.2
	450	EIR 150 45 450 F	2	371	154	344	217	4.0
	600	EIR 150 45 600 F	3	477	198	459	280	4.9
	750	EIR 150 45 750 F	3	583	242	574	342	5.7
	900	EIR 150 45 900 F	3	689	286	689	404	6.5
300	300	EIR 300 45 300 F	2	265	110	230	155	3.4
	450	EIR 300 45 450 F	2	371	154	344	217	4.3
	600	EIR 300 45 600 F	3	477	198	459	280	5.2
	750	EIR 300 45 750 F	3	583	242	574	342	6.1
	900	EIR 300 45 900 F	3	689	286	689	404	6.9
450	300	EIR 450 45 300 F	2	265	110	230	155	3.7
	450	EIR 450 45 450 F	2	371	154	344	217	4.5
	600	EIR 450 45 600 F	3	477	198	459	280	5.6
	750	EIR 450 45 750 F	3	583	242	574	342	6.4
	900	EIR 450 45 900 F	3	689	286	689	404	7.2
600	300	EIR 600 45 300 F	2	265	110	230	155	4.1
	450	EIR 600 45 450 F	2	371	154	344	217	5.0
	600	EIR 600 45 600 F	3	477	198	459	280	6.3
	750	EIR 600 45 750 F	3	583	242	574	342	7.1
	900	EIR 600 45 900 F	3	689	286	689	404	7.9
750	300	EIR 750 45 300 F	2	265	110	230	155	4.8
	450	EIR 750 45 450 F	2	371	154	344	217	5.7
	600	EIR 750 45 600 F	3	477	198	459	280	7.3
	750	EIR 750 45 750 F	3	583	242	574	342	8.1
	900	EIR 750 45 900 F	3	689	286	689	404	9.0
900	300	EIR 900 45 300 F	2	265	110	230	155	5.2
	450	EIR 900 45 450 F	2	371	154	344	217	6.0
	600	EIR 900 45 600 F	3	477	198	459	280	7.9
	750	EIR 900 45 750 F	3	583	242	574	342	8.7
	900	EIR 900 45 900 F	3	689	286	689	404	9.5

(1) Cat. Nos. given in the table are for inside risers. For outside risers substitute EIR for EOR

Dimensions

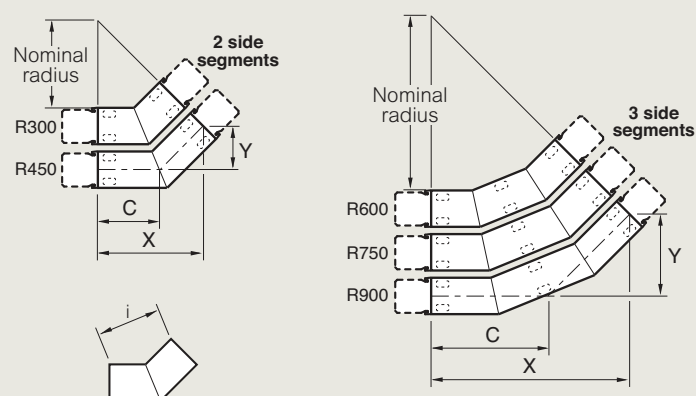

X = length of fitting from each 'end' of centre-line (not including integral coupler)

Y = length from each 'end' of the fitting to the point at which the centre-lines intersect (not including integral coupler)

i = measurement across the inner curve of the fitting

C = length of the centre-line from each 'end' of the fitting to the point at which the centre-lines intersect (not including integral coupler)

Weights

All weights given are in kilograms (kg) and are for hot dip galvanised G finish

To obtain the appropriate component weight in other finishes, multiply the given weight by the following factors :

Deep galvanised (D) x 1.07
Stainless steel (S) x 0.94
Powder coated (E) x 0.97

■ Rung details

Type 1 rungs are used as standard

Type 2 and 3 are only available to special order, see p. 37
Type 1 can be supplied in any combination to special order

Type 1 standard

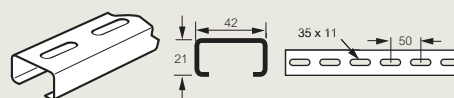

Key : Replace the letter shown in red with your choice from the following options :

F = Finish : G (hot dip galvanised after manufacture)
D (deep galvanised)
S (stainless steel)
E (powder coated)

→ Integral fitting coupler detail : see p. 44

→ Fitting to fitting coupler sets : see p. 45

All dimensions (mm) are nominal

Swifts® 30° inside and outside risers

medium duty (Topaz)

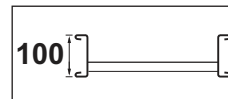

■ Dimensions and weights

Width (W)	Radius (R)	Cat. Nos. ⁽¹⁾	No. of rungs	Dimensions (mm)				Weight (kg)
				X	Y	i	c	
150	300	ZIR 150 30 300 F	2	175	47	155	94	1.3
	450	ZIR 150 30 450 F	2	250	67	233	134	1.7
	600	ZIR 150 30 600 F	2	325	87	311	174	2.0
	750	ZIR 150 30 750 F	2	400	107	388	214	2.3
	900	ZIR 150 30 900 F	2	475	127	466	255	2.6
300	300	ZIR 300 30 300 F	2	175	47	155	94	1.6
	450	ZIR 300 30 450 F	2	250	67	233	134	1.9
	600	ZIR 300 30 600 F	2	325	87	311	174	2.2
	750	ZIR 300 30 750 F	2	400	107	388	214	2.6
	900	ZIR 300 30 900 F	2	475	127	466	255	2.9
450	300	ZIR 450 30 300 F	2	175	47	155	94	1.8
	450	ZIR 450 30 450 F	2	250	67	233	134	2.2
	600	ZIR 450 30 600 F	2	325	87	311	174	2.5
	750	ZIR 450 30 750 F	2	400	107	388	214	2.8
	900	ZIR 450 30 900 F	2	475	127	466	255	3.1
600	300	ZIR 600 30 300 F	2	175	47	155	94	2.3
	450	ZIR 600 30 450 F	2	250	67	233	134	2.6
	600	ZIR 600 30 600 F	2	325	87	311	174	2.9
	750	ZIR 600 30 750 F	2	400	107	388	214	3.3
	900	ZIR 600 30 900 F	2	475	127	466	255	3.6
750	300	ZIR 750 30 300 F	2	175	47	155	94	3.0
	450	ZIR 750 30 450 F	2	250	67	233	134	3.3
	600	ZIR 750 30 600 F	2	325	87	311	174	3.6
	750	ZIR 750 30 750 F	2	400	107	388	214	3.9
	900	ZIR 750 30 900 F	2	475	127	466	255	4.3
900	300	ZIR 900 30 300 F	2	175	47	155	94	3.4
	450	ZIR 900 30 450 F	2	250	67	233	134	3.7
	600	ZIR 900 30 600 F	2	325	87	311	174	4.0
	750	ZIR 900 30 750 F	2	400	107	388	214	4.3
	900	ZIR 900 30 900 F	2	475	127	466	255	4.6

(1) Cat. Nos. given in the table are for inside risers. For outside risers substitute ZIR for ZOR

Dimensions

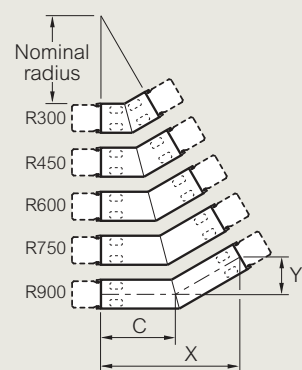

X = length of fitting from each 'end' of centre-line (not including integral coupler)

Y = length from each 'end' of the fitting to the point at which the centre-lines intersect (not including integral coupler)

i = measurement across the inner curve of the fitting

C = length of the centre-line from each 'end' of the fitting to the point at which the centre-lines intersect (not including integral coupler)

Weights

All weights given are in kilograms (kg) and are for hot dip galvanised G finish

To obtain the appropriate component weight in other finishes, multiply the given weight by the following factors :

Deep galvanised (D) x 1.07
 Stainless steel (S) x 0.94
 Powder coated (E) x 0.97

■ Rung details

Type 1 rungs are used as standard

Type 2 and 3 are only available to special order, see p. 37
 Type 1 can be supplied in any combination to special order

Type 1 standard

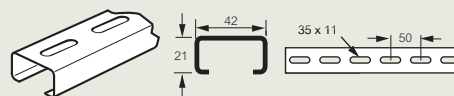

Key : Replace the letter shown in red with your choice from the following options :

F = Finish : G (hot dip galvanised after manufacture)
 D (deep galvanised)
 S (stainless steel)
 E (powder coated)

→ Integral fitting coupler detail : see p. 44

→ Fitting to fitting coupler sets : see p. 45

All dimensions (mm) are nominal

Swifts® 30° inside and outside risers

heavy duty (Sapphire)

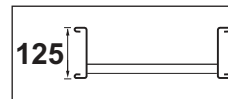

■ Dimensions and weights

Width (W)	Radius (R)	Cat. Nos. ⁽¹⁾	No. of rungs	Dimensions (mm)				Weight (kg)
				X	Y	i	C	
150	300	PIR 150 30 300 F	2	181	49	155	97	1.6
	450	PIR 150 30 450 F	2	256	69	233	137	2.0
	600	PIR 150 30 600 F	2	331	89	311	178	2.4
	750	PIR 150 30 750 F	2	406	109	388	218	2.8
	900	PIR 150 30 900 F	2	481	129	466	258	3.1
300	300	PIR 300 30 300 F	2	181	49	155	97	1.9
	450	PIR 300 30 450 F	2	256	69	233	137	2.2
	600	PIR 300 30 600 F	2	331	89	311	178	2.6
	750	PIR 300 30 750 F	2	406	109	388	218	3.0
	900	PIR 300 30 900 F	2	481	129	466	258	3.4
450	300	PIR 450 30 300 F	2	181	49	155	97	2.1
	450	PIR 450 30 450 F	2	256	69	233	137	2.5
	600	PIR 450 30 600 F	2	331	89	311	178	2.9
	750	PIR 450 30 750 F	2	406	109	388	218	3.2
	900	PIR 450 30 900 F	2	481	129	466	258	3.6
600	300	PIR 600 30 300 F	2	181	49	155	97	2.6
	450	PIR 600 30 450 F	2	256	69	233	137	2.9
	600	PIR 600 30 600 F	2	331	89	311	178	3.3
	750	PIR 600 30 750 F	2	406	109	388	218	3.7
	900	PIR 600 30 900 F	2	481	129	466	258	4.1
750	300	PIR 750 30 300 F	2	181	49	155	97	3.3
	450	PIR 750 30 450 F	2	256	69	233	137	3.6
	600	PIR 750 30 600 F	2	331	89	311	178	4.0
	750	PIR 750 30 750 F	2	406	109	388	218	4.4
	900	PIR 750 30 900 F	2	481	129	466	258	4.8
900	300	PIR 900 30 300 F	2	181	49	155	97	3.6
	450	PIR 900 30 450 F	2	256	69	233	137	4.0
	600	PIR 900 30 600 F	2	331	89	311	178	4.4
	750	PIR 900 30 750 F	2	406	109	388	218	4.8
	900	PIR 900 30 900 F	2	481	129	466	258	5.1

(1) Cat. Nos. given in the table are for inside risers. For outside risers substitute PIR for POR

Dimensions

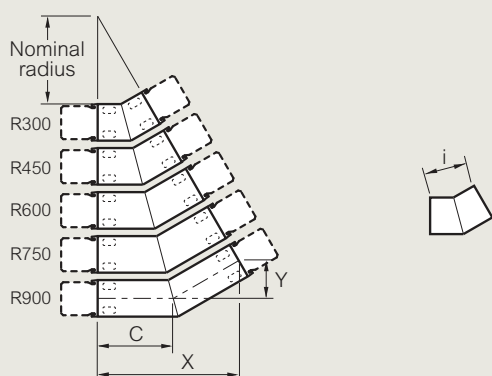

X = length of fitting from each 'end' of centre-line (not including integral coupler)

Y = length from each 'end' of the fitting to the point at which the centre-lines intersect (not including integral coupler)

i = measurement across the inner curve of the fitting

C = length of the centre-line from each 'end' of the fitting to the point at which the centre-lines intersect (not including integral coupler)

Weights

All weights given are in kilograms (kg) and are for hot dip galvanised G finish

To obtain the appropriate component weight in other finishes, multiply the given weight by the following factors :

Deep galvanised (D) x 1.07
 Stainless steel (S) x 0.94
 Powder coated (E) x 0.97

■ Rung details

Type 1 rungs are used as standard

Type 2 and 3 are only available to special order, see p. 37
 Type 1 can be supplied in any combination to special order

Type 1 standard

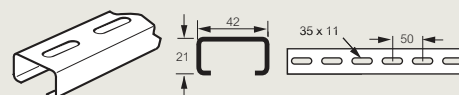

Key : Replace the letter shown in red with your choice from the following options :

F = Finish : G (hot dip galvanised after manufacture)
 D (deep galvanised)
 S (stainless steel)
 E (powder coated)

→ Integral fitting coupler detail : see p. 44

→ Fitting to fitting coupler sets : see p. 45

All dimensions (mm) are nominal

Swifts® 30° inside and outside risers extra heavy duty (Emerald)

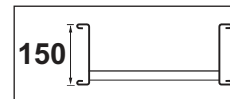

■ Dimensions and weights

Width (W)	Radius (R)	Cat. Nos. ⁽¹⁾	No. of rungs	Dimensions (mm)				Weight (kg)
				X	Y	i	C	
150	300	EIR 150 30 300 F	2	187	50	155	100	2.4
	450	EIR 150 30 450 F	2	262	70	233	141	3.0
	600	EIR 150 30 600 F	2	337	90	311	181	3.5
	750	EIR 150 30 750 F	2	412	111	388	221	4.1
	900	EIR 150 30 900 F	2	487	131	466	261	4.6
300	300	EIR 300 30 300 F	2	187	50	155	100	2.7
	450	EIR 300 30 450 F	2	262	70	233	141	3.2
	600	EIR 300 30 600 F	2	337	90	311	181	3.8
	750	EIR 300 30 750 F	2	412	111	388	221	4.3
	900	EIR 300 30 900 F	2	487	131	466	261	4.9
450	300	EIR 450 30 300 F	2	187	50	155	100	2.9
	450	EIR 450 30 450 F	2	262	70	233	141	3.5
	600	EIR 450 30 600 F	2	337	90	311	181	4.0
	750	EIR 450 30 750 F	2	412	111	388	221	4.6
	900	EIR 450 30 900 F	2	487	131	466	261	5.1
600	300	EIR 600 30 300 F	2	187	50	155	100	3.4
	450	EIR 600 30 450 F	2	262	70	233	141	3.9
	600	EIR 600 30 600 F	2	337	90	311	181	4.5
	750	EIR 600 30 750 F	2	412	111	388	221	5.0
	900	EIR 600 30 900 F	2	487	131	466	261	5.6
750	300	EIR 750 30 300 F	2	187	50	155	100	4.1
	450	EIR 750 30 450 F	2	262	70	233	141	4.6
	600	EIR 750 30 600 F	2	337	90	311	181	5.2
	750	EIR 750 30 750 F	2	412	111	388	221	5.7
	900	EIR 750 30 900 F	2	487	131	466	261	6.3
900	300	EIR 900 30 300 F	2	187	50	155	100	4.4
	450	EIR 900 30 450 F	2	262	70	233	141	5.0
	600	EIR 900 30 600 F	2	337	90	311	181	5.5
	750	EIR 900 30 750 F	2	412	111	388	221	6.1
	900	EIR 900 30 900 F	2	487	131	466	261	6.7

(1) Cat. Nos. given in the table are for inside risers. For outside risers substitute EIR for EOR

Dimensions

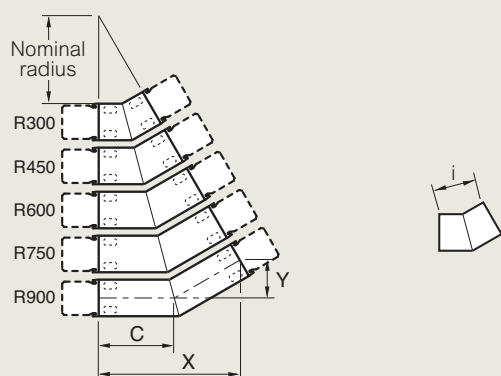

X = length of fitting from each 'end' of centre-line (not including integral coupler)

Y = length from each 'end' of the fitting to the point at which the centre-lines intersect (not including integral coupler)

i = measurement across the inner curve of the fitting

C = length of the centre-line from each 'end' of the fitting to the point at which the centre-lines intersect (not including integral coupler)

Weights

All weights given are in kilograms (kg) and are for hot dip galvanised G finish

To obtain the appropriate component weight in other finishes, multiply the given weight by the following factors :

Deep galvanised (D) x 1.07

Stainless steel (S) x 0.94

Powder coated (E) x 0.97

■ Rung details

Type 1 rungs are used as standard

Type 2 and 3 are only available to special order, see p. 37

Type 1 can be supplied in any combination to special order

Type 1 standard

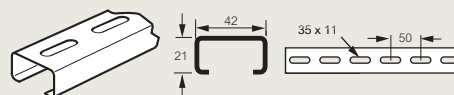

Key : Replace the letter shown in red with your choice from the following options :

F = Finish : G (hot dip galvanised after manufacture)
D (deep galvanised)
S (stainless steel)
E (powder coated)

→ Integral fitting coupler detail : see p. 44

→ Fitting to fitting coupler sets : see p. 45

All dimensions (mm) are nominal

Swifts® equal tees

medium duty (Topaz), heavy duty (Sapphire) and extra heavy duty (Emerald)

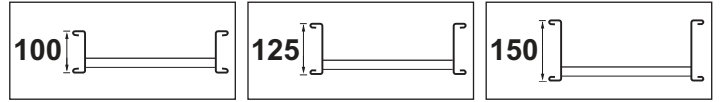

■ Dimensions and weights

Width (W)	Radius (R)	Cat. Nos.	Dimensions (mm)			Weight (kg)		
			X	Y	i	Topaz	Sapphire	Emerald
150	300	XT 150 300R F	454	454	537	5.8	6.7	9.6
	450	XT 150 450R F	604	604	750	7.5	8.7	12.4
	600	XT 150 600R F	754	754	962	9.8	11.2	15.8
	750	XT 150 750R F	904	904	1 174	11.9	13.5	19.0
	900	XT 150 900R F	1 054	1 054	1 386	13.8	15.7	22.0
300	300	XT 300 300R F	529	529	537	7.0	7.9	11.0
	450	XT 300 450R F	679	679	750	9.0	10.2	14.1
	600	XT 300 600R F	829	829	962	11.6	13.0	17.8
	750	XT 300 750R F	979	979	1 174	13.9	15.5	21.2
	900	XT 300 900R F	1 129	1 129	1 386	16.2	18.1	24.6
450	300	XT 450 300R F	604	604	537	8.4	9.3	12.6
	450	XT 450 450R F	754	754	750	10.7	11.9	16.0
	600	XT 450 600R F	904	904	962	14.4	15.9	20.9
	750	XT 450 750R F	1 054	1 054	1 174	16.3	18.0	23.9
	900	XT 450 900R F	1 204	1 204	1 386	19.0	21.0	27.7
600	300	XT 600 300R F	679	679	537	11.0	12.0	15.4
	450	XT 600 450R F	829	829	750	13.7	15.0	19.2
	600	XT 600 600R F	979	979	962	17.1	18.6	23.8
	750	XT 600 750R F	1 129	1 129	1 174	20.0	21.8	27.7
	900	XT 600 900R F	1 279	1 279	1 386	21.9	23.9	30.8
750	300	XT 750 300R F	754	754	537	13.1	14.2	17.7
	450	XT 750 450R F	904	904	750	16.0	17.3	21.7
	600	XT 750 600R F	1 054	1 054	962	20.9	22.5	27.7
	750	XT 750 750R F	1 204	1 204	1 174	22.8	24.6	30.8
	900	XT 750 900R F	1 354	1 354	1 386	29.0	31.1	38.0
900	300	XT 900 300R F	829	829	537	15.9	17.0	20.8
	450	XT 900 450R F	979	979	750	19.1	20.4	25.0
	600	XT 900 600R F	1 129	1 129	962	23.3	24.9	30.3
	750 ⁽¹⁾	XT 900 750R F	1 279	1 279	1 174	29.8	31.6	37.9
	900 ⁽¹⁾	XT 900 900R F	1 429	1 429	1 386	32.2	34.3	41.4

(1) Supplied in 2 parts for assembly on site

Dimensions

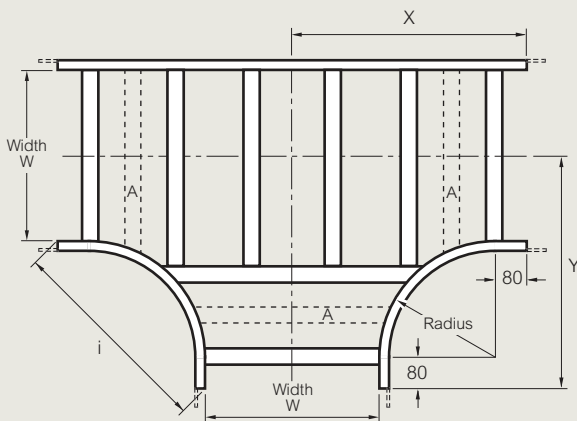

Quantity and spacing of rungs varies with radius and width Nominal pitch = 300. Additional rungs (A) are fitted on tees of 600 radius and above

X = length of fitting from each 'end' of centre-line (not including integral coupler)

Y = length from each 'end' of the fitting to the point at which the centre-lines intersect (not including integral coupler)

i = measurement across the inner curve of the fitting

Weights

All weights given are in kilograms (kg) and are for hot dip galvanised G finish

To obtain the appropriate component weight in other finishes, multiply the given weight by the following factors :

- Deep galvanised (D) x 1.07
- Stainless steel (S) x 0.94
- Powder coated (E) x 0.97

■ Rung details

Type 1 rungs are used as standard

Type 2 and 3 are only available to special order, see p. 37

Type 1 can be supplied in any combination to special order

Type 1 standard

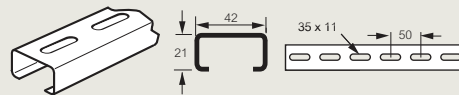

Key : Replace the letter shown in red with your choice from the following options :

- X = Ladder type : Z (Topaz), P (Sapphire), E (Emerald)
- F = Finish : G (hot dip galvanised after manufacture)
 - D (deep galvanised)
 - S (stainless steel)
 - E (powder coated)

➔ Integral fitting coupler detail : see p. 44

➔ Fitting to fitting coupler sets : see p. 45

All dimensions (mm) are nominal

Swifts® unequal tees – 150 mm width

medium duty (Topaz), heavy duty (Sapphire)
and extra heavy duty (Emerald)

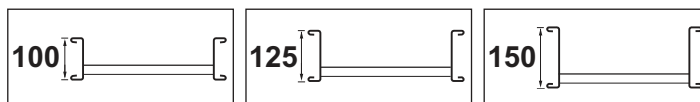

■ Dimensions and weights – unequal tees 150 mm width

Width (W)	Width (B)	Radius (R)	Cat. Nos.	Dimensions (mm)			Weight (kg)		
				X	Y	i	Topaz	Sapphire	Emerald
150	300	300	XUT 150 300 300R F	528	453	537	6.5	7.4	10.5
		450	XUT 150 300 450R F	678	603	750	8.4	9.6	13.5
		600	XUT 150 300 600R F	828	753	962	10.7	12.1	16.9
		750	XUT 150 300 750R F	978	903	1174	12.7	14.4	20.1
		900	XUT 150 300 900R F	1128	1053	1386	14.9	16.8	23.3
	450	300	XUT 150 450 300R F	603	453	537	7.2	8.2	11.4
		450	XUT 150 450 450R F	753	603	750	9.1	10.4	14.5
		600	XUT 150 450 600R F	903	753	962	11.8	13.2	18.2
		750	XUT 150 450 750R F	1053	903	1174	13.6	15.3	21.1
		900	XUT 150 450 900R F	1203	1053	1386	15.7	17.6	24.3
	600	300	XUT 150 600 300R F	678	453	537	8.1	9.1	12.5
		450	XUT 150 600 450R F	828	603	750	10.1	11.3	15.6
		600	XUT 150 600 600R F	978	753	962	12.8	14.3	19.4
		750	XUT 150 600 750R F	1128	903	1174	14.9	16.7	22.6
		900	XUT 150 600 900R F	1278	1053	1386	16.8	18.7	25.6
	750	300	XUT 150 750 300R F	753	453	537	8.9	10.0	13.6
		450	XUT 150 750 450R F	903	603	750	10.9	12.2	16.7
		600	XUT 150 750 600R F	1053	753	962	14.1	15.6	20.9
		750	XUT 150 750 750R F	1203	903	1174	15.9	17.7	23.9
		900	XUT 150 750 900R F	1353	1053	1386	18.1	20.1	27.2
900	300	XUT 150 900 300R F	828	453	537	9.8	10.9	14.6	
	450	XUT 150 900 450R F	978	603	750	11.8	13.2	17.8	
	600	XUT 150 900 600R F	1128	753	962	14.9	16.5	22.0	
	750	XUT 150 900 750R F	1278	903	1174	17.1	18.9	25.2	
	900	XUT 150 900 900R F	1428	1053	1386	19.0	21.0	28.2	

Dimensions

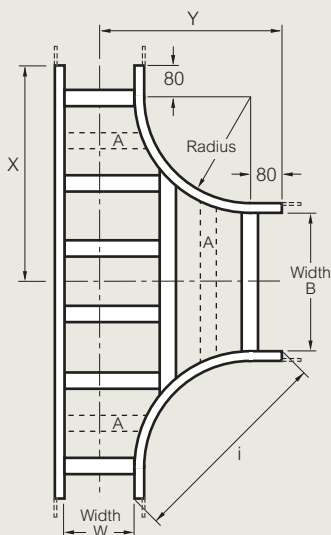

Quantity and spacing of rungs varies with radius and width, nominal pitch = 300

Additional rungs (A) are fitted on tees of 600 radius and above

Weights

All weights given are in kilograms (kg) and are for hot dip galvanised G finish

To obtain the appropriate component weight in other finishes, multiply the given weight by the following factors :

Deep galvanised (D) x 1.07

Stainless steel (S) x 0.94

Powder coated (E) x 0.97

■ Rung details

Type 1 rungs are used as standard

Type 2 and 3 are only available to special order, see p. 37

Type 1 can be supplied in any combination to special order

Type 1 standard

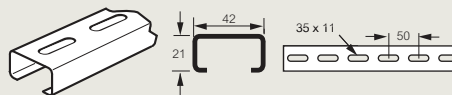

X = length of fitting from each 'end' of centre-line (not including integral coupler)

Y = length from each 'end' of the fitting to the point at which the centre-lines intersect (not including integral coupler)

i = measurement across the inner curve of the fitting

Key : Replace the letter shown in red with your choice from the following options :

X = Ladder type : Z (Topaz), P (Sapphire), E (Emerald)

F = Finish : G (hot dip galvanised after manufacture)

D (deep galvanised)

S (stainless steel)

E (powder coated)

→ Integral fitting coupler detail : see p. 44

→ Fitting to fitting coupler sets : see p. 45

Swifts® unequal tees – 300 mm width

medium duty (Topaz), heavy duty (Sapphire) and extra heavy duty (Emerald)

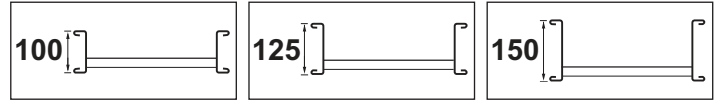

■ Dimensions and weights – unequal tees 300 mm width

Width (W)	Width (B)	Radius (R)	Cat. Nos.	Dimensions (mm)			Weight (kg)		
				X	Y	i	Topaz	Sapphire	Emerald
300	150	300	XUT 300 150 300R F	453	528	537	6.3	7.2	10.1
		450	XUT 300 150 450R F	603	678	750	8.0	9.1	12.9
		600	XUT 300 150 600R F	753	828	962	10.7	12.1	16.7
		750	XUT 300 150 750R F	903	978	1174	13.0	14.6	20.1
		900	XUT 300 150 900R F	1053	1128	1386	15.0	16.8	23.2
	450	300	XUT 300 450 300R F	603	528	537	7.7	8.7	11.9
		450	XUT 300 450 450R F	753	678	750	9.8	11.0	15.1
		600	XUT 300 450 600R F	903	828	962	12.9	14.3	19.3
		750	XUT 300 450 750R F	1053	978	1174	14.7	16.4	22.2
		900	XUT 300 450 900R F	1203	1128	1386	17.1	19.0	25.7
	600	300	XUT 300 600 300R F	678	528	537	8.7	9.7	13.1
		450	XUT 300 600 450R F	828	678	750	10.8	12.1	16.3
		600	XUT 300 600 600R F	978	828	962	13.9	15.4	20.5
		750	XUT 300 600 750R F	1128	978	1174	16.2	18.0	24.0
		900	XUT 300 600 900R F	1278	1128	1386	18.1	20.1	27.0
	750	300	XUT 300 750 300R F	753	528	537	9.5	10.6	14.2
		450	XUT 300 750 450R F	903	678	750	11.6	13.0	17.4
		600	XUT 300 750 600R F	1053	828	962	15.4	16.9	22.2
		750	XUT 300 750 750R F	1203	978	1174	17.3	19.0	25.2
		900	XUT 300 750 900R F	1353	1128	1386	19.7	21.7	28.7
	900	300	XUT 300 900 300R F	828	528	537	10.5	11.6	15.4
		450	XUT 300 900 450R F	978	678	750	12.6	14.0	18.6
		600	XUT 300 900 600R F	1128	828	962	16.2	17.8	23.3
		750	XUT 300 900 750R F	1278	978	1174	18.6	20.4	26.8
900		XUT 300 900 900R F	1428	1128	1386	20.5	22.6	29.8	

Dimensions

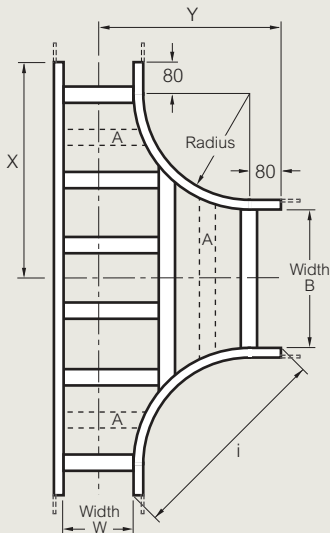

Quantity and spacing of rungs varies with radius and width, nominal pitch = 300

Additional rungs (A) are fitted on tees of 600 radius and above

X = length of fitting from each 'end' of centre-line (not including integral coupler)

Y = length from each 'end' of the fitting to the point at which the centre-lines intersect (not including integral coupler)

i = measurement across the inner curve of the fitting

Weights

All weights given are in kilograms (kg) and are for hot dip galvanised G finish

To obtain the appropriate component weight in other finishes, multiply the given weight by the following factors :

- Deep galvanised (D) x 1.07
- Stainless steel (S) x 0.94
- Powder coated (E) x 0.97

■ Rung details

Type 1 rungs are used as standard

Type 2 and 3 are only available to special order, see p. 37
Type 1 can be supplied in any combination to special order

Type 1 standard

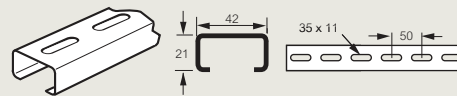

Key : Replace the letter shown in red with your choice from the following options :

X = Ladder type : Z (Topaz), P (Sapphire), E (Emerald)

F = Finish : G (hot dip galvanised after manufacture)

D (deep galvanised)

S (stainless steel)

E (powder coated)

→ Integral fitting coupler detail : see p. 44

→ Fitting to fitting coupler sets : see p. 45

Swifts® unequal tees – 450 mm width

medium duty (Topaz), heavy duty (Sapphire)
and extra heavy duty (Emerald)

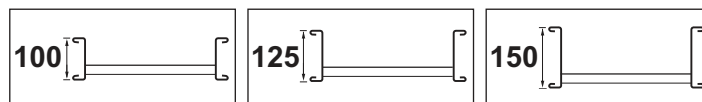

■ Dimensions and weights – unequal tees 450 mm width

Width (W)	Width (B)	Radius (R)	Cat. Nos.	Dimensions (mm)			Weight (kg)		
				X	Y	i	Topaz	Sapphire	Emerald
450	150	300	XUT 450 150 300R F	453	603	537	7-0	7-9	10-8
		450	XUT 450 150 450R F	603	753	750	8-7	9-8	13-6
		600	XUT 450 150 600R F	753	903	962	12-0	13-4	18-0
		750	XUT 450 150 750R F	903	1053	1174	14-6	16-2	21-7
		900	XUT 450 150 900R F	1053	1203	1386	16-6	18-5	24-8
	300	300	XUT 450 300 300R F	528	603	537	7-6	8-6	11-6
		450	XUT 450 300 450R F	678	753	750	9-9	11-1	15-0
		600	XUT 450 300 600R F	828	903	962	12-9	14-3	19-1
		750	XUT 450 300 750R F	978	1053	1174	15-5	17-1	22-8
		900	XUT 450 300 900R F	1128	1203	1386	18-2	20-1	26-6
	600	300	XUT 450 600 300R F	678	603	537	9-6	10-6	14-0
		450	XUT 450 600 450R F	828	753	750	11-9	13-2	17-5
		600	XUT 450 600 600R F	978	903	962	15-5	17-0	22-1
		750	XUT 450 600 750R F	1128	1053	1174	18-2	19-9	25-9
		900	XUT 450 600 900R F	1278	1203	1386	20-1	22-9	28-9
	750	300	XUT 450 750 300R F	753	603	537	10-4	11-5	15-1
		450	XUT 450 750 450R F	903	753	750	12-8	14-1	18-5
		600	XUT 450 750 600R F	1053	903	962	17-3	18-8	24-1
		750	XUT 450 750 750R F	1203	1053	1174	19-2	21-0	27-1
		900	XUT 450 750 900R F	1353	1203	1386	22-0	24-0	31-0
	900	300	XUT 450 900 300R F	828	603	537	11-6	12-7	16-5
		450	XUT 450 900 450R F	978	753	750	14-0	15-4	20-0
		600	XUT 450 900 600R F	1128	903	962	18-1	19-7	25-2
		750	XUT 450 900 750R F	1278	1053	1174	20-9	22-7	29-0
900		XUT 450 900 900R F	1428	1203	1386	22-8	24-9	32-1	

Dimensions

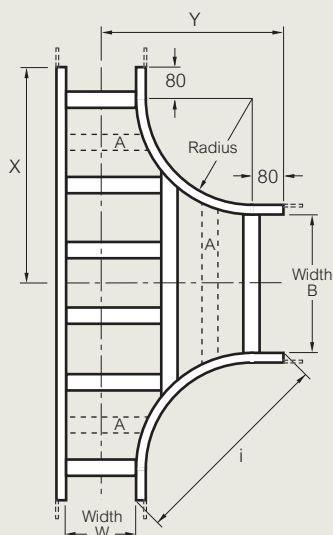

Quantity and spacing of rungs varies with radius and width, nominal pitch = 300

Additional rungs (A) are fitted on tees of 600 radius and above

Weights

All weights given are in kilograms (kg) and are for hot dip galvanised G finish

To obtain the appropriate component weight in other finishes, multiply the given weight by the following factors :

Deep galvanised (D) x 1.07
Stainless steel (S) x 0.94
Powder coated (E) x 0.97

■ Rung details

Type 1 rungs are used as standard

Type 2 and 3 are only available to special order, see p. 37
Type 1 can be supplied in any combination to special order

Type 1 standard

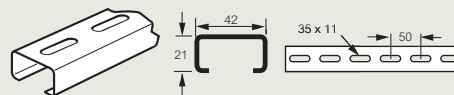

X = length of fitting from each 'end' of centre-line (not including integral coupler)

Y = length from each 'end' of the fitting to the point at which the centre-lines intersect (not including integral coupler)

i = measurement across the inner curve of the fitting

Key : Replace the letter shown in red with your choice from the following options :

X = Ladder type : Z (Topaz), P (Sapphire), E (Emerald)
F = Finish : G (hot dip galvanised after manufacture)
D (deep galvanised)
S (stainless steel)
E (powder coated)

→ Integral fitting coupler detail : see p. 44

→ Fitting to fitting coupler sets : see p. 45

Swifts® unequal tees – 600 mm width

medium duty (Topaz), heavy duty (Sapphire) and extra heavy duty (Emerald)

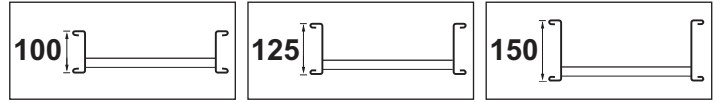

■ Dimensions and weights – unequal tees 600 mm width

Width (W)	Width (B)	Radius (R)	Cat. Nos.	Dimensions (mm)			Weight (kg)		
				X	Y	i	Topaz	Sapphire	Emerald
600	150	300	XUT 600 150 300R F	453	678	537	8.1	9.0	11.9
		450	XUT 600 150 450R F	603	828	750	9.8	11.0	14.7
		600	XUT 600 150 600R F	753	978	962	13.5	14.8	19.4
		750	XUT 600 150 750R F	903	1128	1174	16.2	17.8	23.3
		900	XUT 600 150 900R F	1053	1278	1386	18.3	20.1	26.5
	300	300	XUT 600 300 300R F	528	678	537	8.7	9.7	12.7
		450	XUT 600 300 450R F	678	828	750	11.4	12.5	16.5
		600	XUT 600 300 600R F	828	978	962	14.3	15.7	20.5
		750	XUT 600 300 750R F	978	1128	1174	17.1	18.8	24.4
		900	XUT 600 300 900R F	1128	1278	1386	20.1	21.9	28.5
	450	300	XUT 600 450 300R F	603	678	537	9.5	10.4	13.7
		450	XUT 600 450 450R F	753	828	750	12.1	13.3	17.4
		600	XUT 600 450 600R F	903	978	962	16.1	17.5	22.5
		750	XUT 600 450 750R F	1053	1128	1174	18.0	19.7	25.5
		900	XUT 600 450 900R F	1203	1278	1386	20.9	22.8	29.5
	750	300	XUT 600 750 300R F	753	678	537	11.8	12.9	16.5
		450	XUT 600 750 450R F	903	828	750	14.6	15.9	20.3
		600	XUT 600 750 600R F	1053	978	962	19.1	20.6	25.9
		750	XUT 600 750 750R F	1203	1128	1174	21.0	22.8	29.0
		900	XUT 600 750 900R F	1353	1278	1386	24.0	26.1	33.1
	900	300	XUT 600 900 300R F	828	678	537	13.3	14.5	18.2
		450	XUT 600 900 450R F	978	828	750	16.1	17.5	22.1
		600	XUT 600 900 600R F	1128	978	962	20.0	21.6	27.0
		750	XUT 600 900 750R F	1278	1128	1174	22.9	24.7	31.1
900		XUT 600 900 900R F	1428	1278	1386	24.9	27.0	34.2	

Dimensions

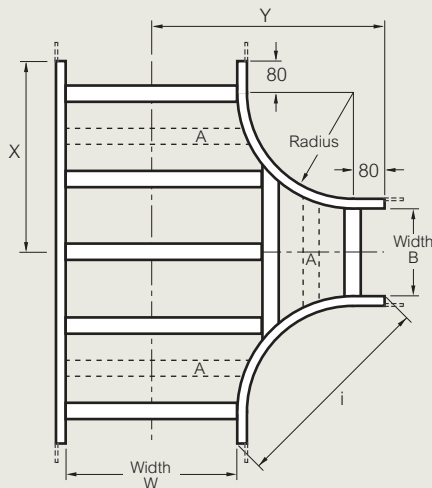

Quantity and spacing of rungs varies with radius and width, nominal pitch = 300
Additional rungs (A) are fitted on tees of 600 radius and above

X = length of fitting from each 'end' of centre-line (not including integral coupler)

Y = length from each 'end' of the fitting to the point at which the centre-lines intersect (not including integral coupler)

i = measurement across the inner curve of the fitting

Weights

All weights given are in kilograms (kg) and are for hot dip galvanised G finish

To obtain the appropriate component weight in other finishes, multiply the given weight by the following factors :

- Deep galvanised (D) x 1.07
- Stainless steel (S) x 0.94
- Powder coated (E) x 0.97

■ Rung details

Type 1 rungs are used as standard

Type 2 and 3 are only available to special order, see p. 37
Type 1 can be supplied in any combination to special order

Type 1 standard

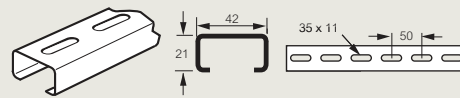

Key : Replace the letter shown in red with your choice from the following options :

- X = Ladder type : Z (Topaz), P (Sapphire), E (Emerald)
- F = Finish : G (hot dip galvanised after manufacture)
 - D (deep galvanised)
 - S (stainless steel)
 - E (powder coated)

→ Integral fitting coupler detail : see p. 44

→ Fitting to fitting coupler sets : see p. 45

Swifts® unequal tees – 750 mm width

medium duty (Topaz), heavy duty (Sapphire) and extra heavy duty (Emerald)

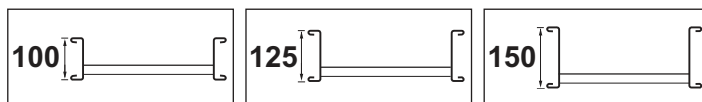

■ Dimensions and weights – unequal tees 750 mm width

Width (W)	Width (B)	Radius (R)	Cat. Nos.	Dimensions (mm)			Weight (kg)		
				X	Y	i	Topaz	Sapphire	Emerald
750	150	300	XUT 750 150 300R F	453	753	537	9.2	10.0	12.9
		450	XUT 750 150 450R F	603	903	750	10.9	12.0	15.8
		600	XUT 750 150 600R F	753	1053	962	14.9	16.3	20.9
		750	XUT 750 150 750R F	903	1203	1174	17.9	19.5	25.0
		900 ⁽¹⁾	XUT 750 150 900R F	1053	1353	1386	23.7	25.5	31.8
	300	300	XUT 750 300 300R F	528	753	537	9.8	10.7	13.8
		450	XUT 750 300 450R F	678	903	750	12.6	13.8	17.7
		600	XUT 750 300 600R F	828	1053	962	15.8	17.2	22.0
		750	XUT 750 300 750R F	978	1203	1174	18.8	20.4	26.1
		900 ⁽¹⁾	XUT 750 300 900R F	1128	1353	1386	24.3	26.2	32.7
	450	300	XUT 750 450 300R F	603	753	537	10.5	11.5	14.7
		450	XUT 750 450 450R F	753	903	750	13.4	14.6	18.7
		600	XUT 750 450 600R F	903	1053	962	17.7	19.2	24.1
		750	XUT 750 450 750R F	1053	1203	1174	19.6	21.3	27.1
		900 ⁽¹⁾	XUT 750 450 900R F	1203	1353	1386	27.5	29.4	36.0
	600	300	XUT 750 600 300R F	678	753	537	12.3	13.3	16.7
		450	XUT 750 600 450R F	828	903	750	15.2	16.4	20.7
		600	XUT 750 600 600R F	978	1053	962	18.8	20.3	25.4
		750	XUT 750 600 750R F	1128	1203	1174	21.8	23.6	29.6
		900 ⁽¹⁾	XUT 750 600 900R F	1278	1353	1386	28.3	30.3	37.1
	900	300	XUT 750 900 300R F	828	753	537	14.8	15.9	19.6
		450	XUT 750 900 450R F	978	903	750	17.7	19.1	23.7
		600	XUT 750 900 600R F	1128	1053	962	21.8	23.4	28.8
		750	XUT 750 900 750R F	1278	1203	1174	24.9	26.7	33.0
900 ⁽¹⁾		XUT 750 900 900R F	1428	1353	1386	30.2	32.3	39.4	

(1) Supplied in 2 parts for assembly on site

Dimensions

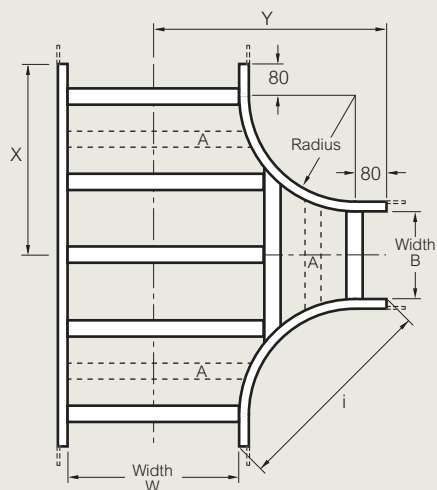

Quantity and spacing of rungs varies with radius and width, nominal pitch = 300
Additional rungs (A) are fitted on tees of 600 radius and above

Weights

All weights given are in kilograms (kg) and are for hot dip galvanised G finish

To obtain the appropriate component weight in other finishes, multiply the given weight by the following factors :

Deep galvanised (D) x 1.07
Stainless steel (S) x 0.94
Powder coated (E) x 0.97

■ Rung details

Type 1 rungs are used as standard

Type 2 and 3 are only available to special order, see p. 37
Type 1 can be supplied in any combination to special order

Type 1 standard

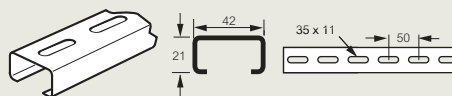

X = length of fitting from each 'end' of centre-line (not including integral coupler)

Y = length from each 'end' of the fitting to the point at which the centre-lines intersect (not including integral coupler)

i = measurement across the inner curve of the fitting

Key : Replace the letter shown in red with your choice from the following options :

X = Ladder type : Z (Topaz), P (Sapphire), E (Emerald)
F = Finish : G (hot dip galvanised after manufacture)
D (deep galvanised)
S (stainless steel)
E (powder coated)

→ Integral fitting coupler detail : see p. 44

→ Fitting to fitting coupler sets : see p. 45

All dimensions (mm) are nominal

Swifts® unequal tees – 900 mm width

medium duty (Topaz), heavy duty (Sapphire) and extra heavy duty (Emerald)

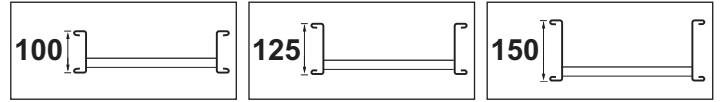

■ Dimensions and weights – unequal tees 900 mm width

Width (W)	Width (B)	Radius (R)	Cat. Nos.	X	Y	i	Weight (kg)		
							Topaz	Sapphire	Emerald
900	150	300	XUT 900 150 300R F	453	828	537	9.9	10.8	13.7
		450	XUT 900 150 450R F	603	978	750	11.6	12.8	16.5
		600	XUT 900 150 600R F	753	1128	962	16.0	17.4	22.0
		750 ⁽¹⁾	XUT 900 150 750R F	903	1278	1174	23.0	24.6	30.0
		900 ⁽¹⁾	XUT 900 150 900R F	1053	1428	1386	25.3	27.2	33.4
	300	300	XUT 900 300 300R F	528	828	537	10.5	11.5	14.5
		450	XUT 900 300 450R F	678	978	750	13.5	14.7	18.6
		600	XUT 900 300 600R F	828	1128	962	16.9	18.3	23.1
		750 ⁽¹⁾	XUT 900 300 750R F	978	1278	1174	23.7	25.3	30.9
		900 ⁽¹⁾	XUT 900 300 900R F	1128	1428	1386	26.0	27.9	34.3
	450	300	XUT 900 450 300R F	603	828	537	11.3	12.2	15.5
		450	XUT 900 450 450R F	753	978	750	14.3	15.5	19.6
		600	XUT 900 450 600R F	903	1128	962	19.0	20.5	25.4
		750 ⁽¹⁾	XUT 900 450 750R F	1053	1278	1174	24.4	26.1	31.8
		900 ⁽¹⁾	XUT 900 450 900R F	1203	1428	1386	29.5	31.4	38.0
	600	300	XUT 900 600 300R F	678	828	537	13.2	14.2	17.6
		450	XUT 900 600 450R F	828	978	750	16.3	17.5	21.8
		600	XUT 900 600 600R F	978	1128	962	20.1	21.6	26.7
		750 ⁽¹⁾	XUT 900 600 750R F	1128	1278	1174	27.9	29.7	35.6
	750	300	XUT 900 750 300R F	753	828	537	14.0	15.1	18.7
450		XUT 900 750 450R F	903	978	750	17.1	18.4	22.9	
600		XUT 900 750 600R F	1053	1128	962	22.4	24.0	29.2	
750 ⁽¹⁾		XUT 900 750 750R F	1203	1278	1174	28.6	30.4	36.5	
900 ⁽¹⁾		XUT 900 750 900R F	1353	1428	1386	31.0	33.1	40.0	

(1) Supplied in 2 parts for assembly on site

Dimensions

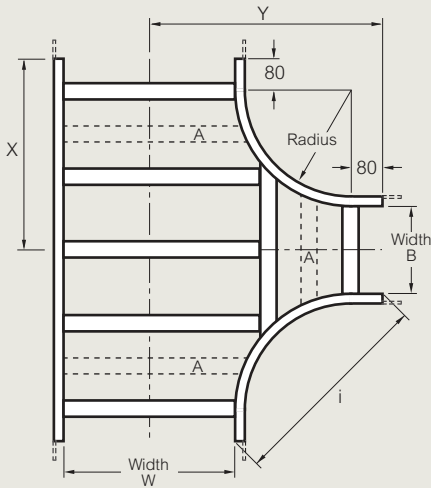

Quantity and spacing of rungs varies with radius and width, nominal pitch = 300
Additional rungs (A) are fitted on tees of 600 radius and above

Weights

All weights given are in kilograms (kg) and are for hot dip galvanised G finish

To obtain the appropriate component weight in other finishes, multiply the given weight by the following factors :

- Deep galvanised (D) x 1.07
- Stainless steel (S) x 0.94
- Powder coated (E) x 0.97

■ Rung details

Type 1 rungs are used as standard

Type 2 and 3 are only available to special order, see p. 37
Type 1 can be supplied in any combination to special order

Type 1 standard

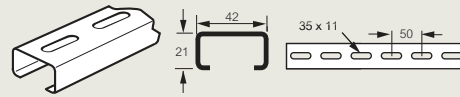

X = length of fitting from each 'end' of centre-line (not including integral coupler)

Y = length from each 'end' of the fitting to the point at which the centre-lines intersect (not including integral coupler)

i = measurement across the inner curve of the fitting

Key : Replace the letter shown in red with your choice from the following options :

- X = Ladder type : Z (Topaz), P (Sapphire), E (Emerald)
- F = Finish : G (hot dip galvanised after manufacture)
- D (deep galvanised)
- S (stainless steel)
- E (powder coated)

→ Integral fitting coupler detail : see p. 44

→ Fitting to fitting coupler sets : see p. 45

All dimensions (mm) are nominal

Swifts® branch pieces

medium duty (Topaz), heavy duty (Sapphire) and extra heavy duty (Emerald)

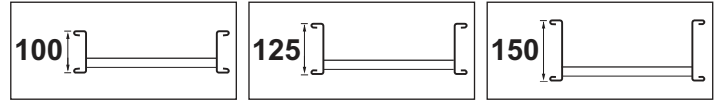

■ Dimensions and weights

Width (W)	Radius (R)	Cat. Nos.	No of rungs	Dimensions (mm)		Weight (kg)		
				X	Topaz	Sapphire	Emerald	
150	300	XB 150 300R F	2	907	4.6	5.1	6.8	
300	300	XB 300 300R F	2	1 057	5.4	5.9	7.6	
450	300	XB 450 300R F	2 + 1	1 207	6.2	6.7	8.4	
600	300	XB 600 300R F	2 + 1	1 357	6.9	7.4	9.1	
750	300	XB 750 300R F	2 + 2	1 507	7.7	8.2	9.9	
900	300	XB 900 300R F	2 + 2	1 657	8.4	8.8	10.5	

Dimensions

300 mm wide branch

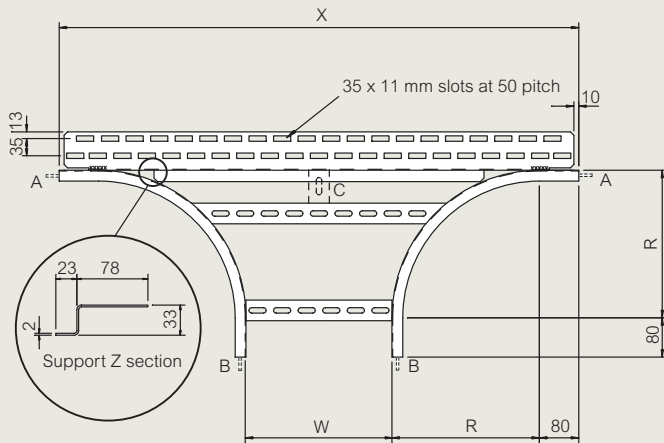

- A = Special integral coupler
 - B = Standard integral coupler
 - R = Radius (300 mm)
 - W = Width
 - X = Length of fitting (excluding coupler)
 - C = Additional rungs on wider branches
- Additional rungs are added for extra support :
 450 mm and 600 mm wide : one additional rung
 750 mm and 900 mm wide : two additional rungs

■ Installation and assembly

When mounting branch piece, a section of the ladder side rail must be removed

300 mm wide branch

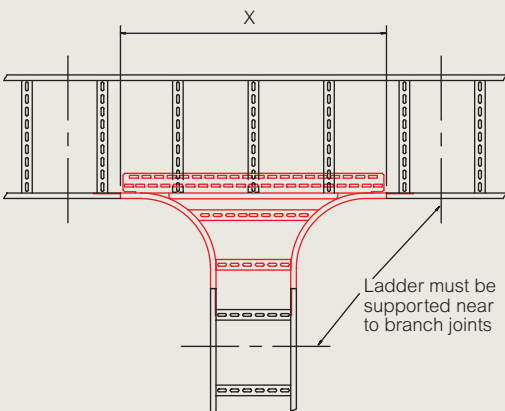

Key : Replace the letter shown in red with your choice from the following options :

- X** = Ladder type : **Z** (Topaz), **P** (Sapphire), **E** (Emerald)
- F** = Finish : **G** (hot dip galvanised after manufacture)
D (deep galvanised)
S (stainless steel)
E (powder coated)

■ Installation and assembly (continued)

Special integral couplers

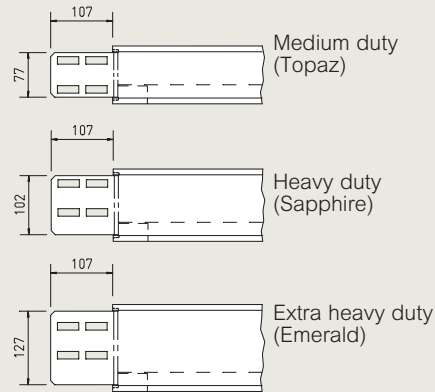

Special integral couplers (reduced height) are used in position A (left) to allow easy fit up to cut siderail of mating straight length
 For standard integral couplers, see p. 44

Fasteners

For fitting integral couplers use M10 coachbolt with flange nut
 For fixing support section to rungs of mating ladder use M10 coachbolt with flange nut

Width W	No rung fixings
150	3
300	4
450	4
600	5
750	5
900	6

Weights

All weights given are in kilograms (kg) and are for hot dip galvanised G finish.
 To obtain the appropriate component weight in other finishes, multiply the given weight by the following factors :
 Deep galvanised (D) x 1.07
 Stainless steel (S) x 0.94
 Powder coated (E) x 0.97

■ Rung details

Type 1 rungs are used as standard

Type 2 and 3 are only available to special order, see p. 37
 Type 1 can be supplied in any combination to special order

Type 1 standard

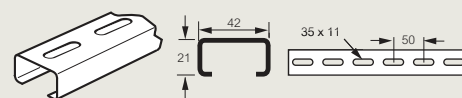

All dimensions (mm) are nominal

➔ Integral fitting coupler detail : see p. 44

➔ Fitting to fitting coupler sets : see p. 45

Swifts® 4 way crosspieces

medium duty (Topaz), heavy duty (Sapphire) and extra heavy duty (Emerald)

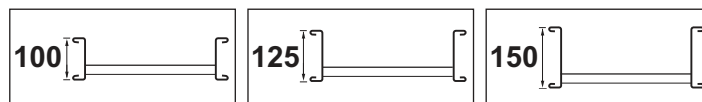

■ Dimensions and weights

Width (W)	Radius (R)	Cat. Nos.	Dimensions (mm)			Weight (kg)		
			X	Y	i	Topaz	Sapphire	Emerald
150	300	XX 150 300R F	454	454	537	7.8	8.9	12.3
	450	XX 150 450R F	604	604	750	10.2	11.6	16.1
	600	XX 150 600R F	754	754	962	13.6	15.2	20.8
300	300	XX 300 300R F	529	529	537	9.4	10.4	13.9
	450	XX 300 450R F	679	679	750	12.1	13.5	18.0
450	300	XX 450 300R F	604	604	537	11.2	12.2	15.7
	450	XX 450 450R F	754	754	750	14.5	15.9	20.3
600	300	XX 600 300R F	679	679	537	14.0	15.1	18.5
750	300	XX 750 300R F	754	754	537	16.9	18.0	21.4

Crosspieces in larger width/radius combinations are supplied in two identical halves for on-site assembly. Information on dimensions and weights, together with assembly details, are given opposite

Dimensions

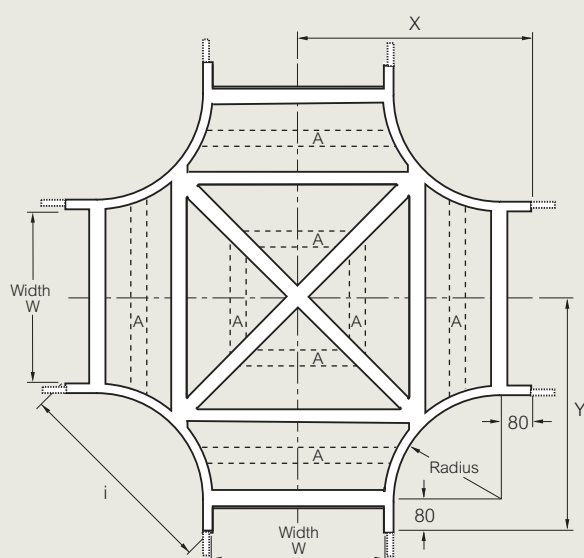

Additional rungs (A) are fitted to large radius crosspieces

X = length of fitting from each 'end' of centre-line (not including integral coupler)

Y = length from each 'end' of the fitting to the point at which the centre-lines intersect (not including integral coupler)

i = measurement across the inner curve of the fitting

Weights

All weights given are in kilograms (kg) and are for hot dip galvanised G finish

To obtain the appropriate component weight in other finishes, multiply the given weight by the following factors :

Deep galvanised (D) x 1.07

Stainless steel (S) x 0.94

Powder coated (E) x 0.97

■ Rung details

Type 1 rungs are used as standard

Type 2 and 3 are only available to special order, see p. 37

Type 1 can be supplied in any combination to special order

Type 1 standard

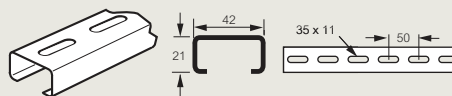

Key : Replace the letter shown in red with your choice from the following options :

X = Ladder type : Z (Topaz), P (Sapphire), E (Emerald)

F = Finish : G (hot dip galvanised after manufacture)

D (deep galvanised)

S (stainless steel)

E (powder coated)

All dimensions (mm) are nominal

→ Integral fitting coupler detail : see p. 44

→ Fitting to fitting coupler sets : see p. 45

Swifts® 4 way crosspieces - 2 piece units

medium duty (Topaz), heavy duty (Sapphire) and extra heavy duty (Emerald)

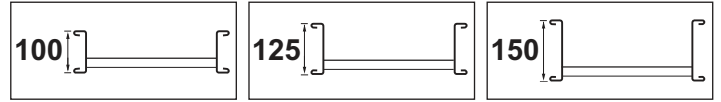

■ Dimensions and weights

Width (W)	Radius (R)	Cat. Nos.	Dimensions (mm)			Weight (kg)		
			X	Y	i	Topaz	Sapphire	Emerald
150	750	XX 150 750R F	904	904	1 174	20.8	22.7	29.3
	900	XX 150 900R F	1 054	1 054	1 386	24.5	26.7	34.4
300	600	XX 300 600R F	829	829	962	15.9	17.6	23.1
	750	XX 300 750R F	979	979	1 174	23.3	25.2	31.8
	900	XX 300 900R F	1 129	1 129	1 386	27.3	29.5	37.2
450	600	XX 450 600R F	904	904	962	22.3	23.9	29.5
	750	XX 450 750R F	1 054	1 054	1 174	25.7	27.6	34.3
	900	XX 450 900R F	1 204	1 204	1 386	29.8	32.0	39.7
600	450	XX 600 450R F	829	829	750	16.6	18.0	22.5
	600	XX 600 600R F	979	979	962	25.1	26.8	32.3
	750	XX 600 750R F	1 129	1 129	1 174	29.3	31.2	37.8
	900	XX 600 900R F	1 279	1 279	1 386	33.5	35.7	43.4
750	450	XX 750 450R F	904	904	750	22.0	23.3	27.8
	600	XX 750 600R F	1 054	1 054	962	29.4	31.0	36.6
	750	XX 750 750R F	1 204	1 204	1 174	32.9	34.9	41.5
	900	XX 750 900R F	1 354	1 354	1 386	37.6	39.9	47.5
900	300	XX 900 300R F	829	829	537	19.0	20.0	23.5
	450	XX 900 450R F	979	979	750	25.7	27.1	31.6
	600	XX 900 600R F	1 129	1 129	962	32.1	33.7	39.3
	750	XX 900 750R F	1 279	1 279	1 174	37.2	39.1	45.7
	900	XX 900 900R F	1 429	1 429	1 386	42.5	44.7	52.4

Dimensions

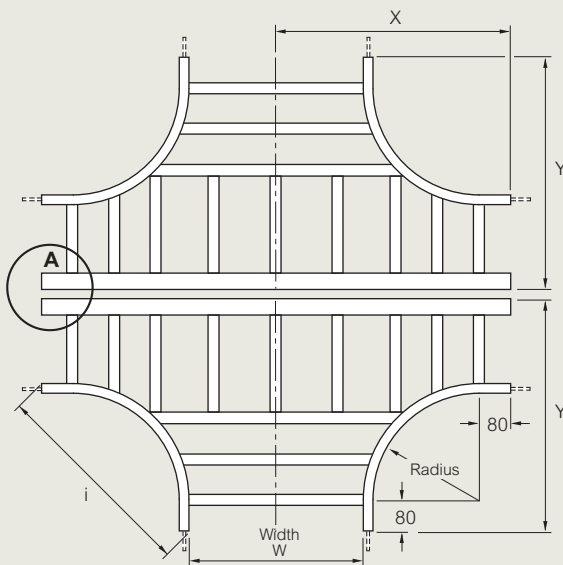

Assembly detail for two piece units - detail A, see opposite

X = length of fitting from each 'end' of centre-line (not including integral coupler)

Y = length from each 'end' of the fitting to the point at which the centre-lines intersect (not including integral coupler)

i = measurement across the inner curve of the fitting

Key : Replace the letter shown in red with your choice from the following options :

- X = Ladder type : Z (Topaz), P (Sapphire), E (Emerald)
- F = Finish : G (hot dip galvanised after manufacture)
 - D (deep galvanised)
 - S (stainless steel)
 - E (powder coated)

Assembly detail for two piece units - detail A (opposite)

(Fasteners included)

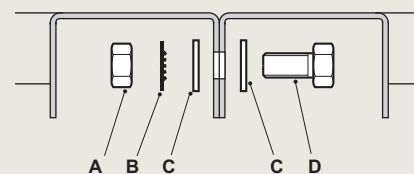

- A M6 nut
- B Shakeproof washer
- C Flat washer
- roofing washers for G and D
- form A for S
- D M6 x 16 set screw

Weights

All weights given are in kilograms (kg) and are for hot dip galvanised G finish

To obtain the appropriate component weight in other finishes, multiply the given weight by the following factors :

- Deep galvanised (D) x 1.07
- Stainless steel (S) x 0.94
- Powder coated (E) x 0.97

■ Rung details

Type 1 rungs are used as standard

Type 2 and 3 are only available to special order, see p. 37
Type 1 can be supplied in any combination to special order

Type 1 standard

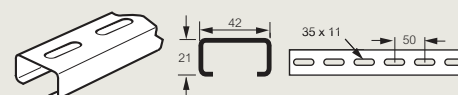

All dimensions (mm) are nominal

→ Integral fitting coupler detail : see p. 44

→ Fitting to fitting coupler sets : see p. 45

Swifts® straight reducers

medium duty (Topaz), heavy duty (Sapphire) and extra heavy duty (Emerald)

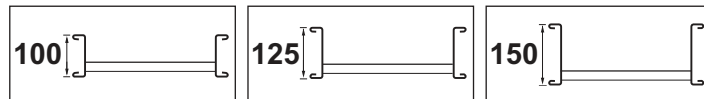

■ Dimensions and weights

Width (W)	Width (K)	Cat. Nos.	Length	Weight (kg)		
				Topaz	Sapphire	Emerald
300	150	XSR 300 150 F	450	2.5	3.0	4.4
450	150	XSR 450 150 F	450	2.9	3.4	4.9
	300	XSR 450 300 F	450	2.8	3.2	4.6
600	150	XSR 600 150 F	500	3.5	4.1	5.8
	300	XSR 600 300 F	450	3.2	3.7	5.2
	450	XSR 600 450 F	450	3.1	3.6	5.0
750	150	XSR 750 150 F	500	4.1	4.7	6.5
	300	XSR 750 300 F	500	4.0	4.5	6.3
	450	XSR 750 450 F	450	3.7	4.2	5.7
	600	XSR 750 600 F	450	3.7	4.2	5.5
900	150	XSR 900 150 F	500	4.7	5.3	7.4
	300	XSR 900 300 F	500	4.4	5.0	6.8
	450	XSR 900 450 F	500	4.3	4.8	6.6
	600	XSR 900 600 F	450	4.1	4.6	6.1
	750	XSR 900 750 F	450	4.2	4.7	6.1

Dimensions

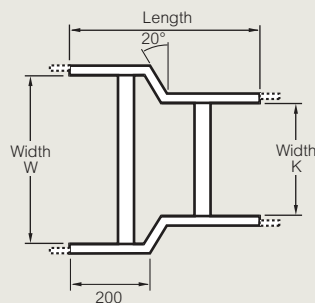

Weights

All weights given are in kilograms (kg) and are for hot dip galvanised G finish

To obtain the appropriate component weight in other finishes, multiply the given weight by the following factors :

- Deep galvanised (D) x 1.07
- Stainless steel (S) x 0.94
- Powder coated (E) x 0.97

■ Rung details

Type 1 rungs are used as standard

Type 2 and 3 are only available to special order, see p. 37
Type 1 can be supplied in any combination to special order

Type 1 standard

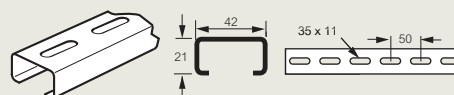

Key : Replace the letter shown in red with your choice from the following options :

- X = Ladder type : Z (Topaz), P (Sapphire), E (Emerald)
- F = Finish : G (hot dip galvanised after manufacture)
 - D (deep galvanised)
 - S (stainless steel)
 - E (powder coated)

All dimensions (mm) are nominal

→ Integral fitting coupler detail : see p. 44

→ Fitting to fitting coupler sets : see p. 45

Swifts® offset reducers

medium duty (Topaz), heavy duty (Sapphire) and extra heavy duty (Emerald)

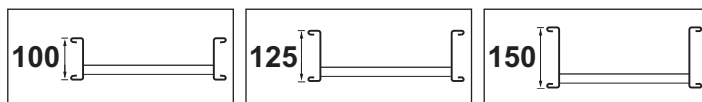

■ Dimensions and weights

Width (W)	Width (K)	Cat. Nos. ⁽¹⁾	Length	Weight (kg)		
				Topaz	Sapphire	Emerald
300	150	XLR 300 150 F	450	2.7	3.1	4.6
450	150	XLR 450 150 F	500	3.2	3.7	5.4
	300	XLR 450 300 F	450	2.9	3.4	4.8
600	150	XLR 600 150 F	550	3.9	4.4	6.3
	300	XLR 600 300 F	500	3.6	4.1	5.8
	450	XLR 600 450 F	450	3.3	3.7	5.2
750	150	XLR 750 150 F	600	4.6	5.3	7.4
	300	XLR 750 300 F	550	4.3	4.9	6.8
	450	XLR 750 450 F	500	4.0	4.6	6.2
	600	XLR 750 600 F	450	3.9	4.3	5.7
900	150	XLR 900 150 F	650	5.2	5.9	8.3
	300	XLR 900 300 F	600	4.9	5.6	7.7
	450	XLR 900 450 F	550	4.6	5.2	7.1
	600	XLR 900 600 F	500	4.5	5.0	6.6
	750	XLR 900 750 F	450	4.4	4.8	6.3

(1) Cat. Nos. given in the table are for left hand reducers. For right hand reducers substitute XLR for XRR

Dimensions

Left hand reducer

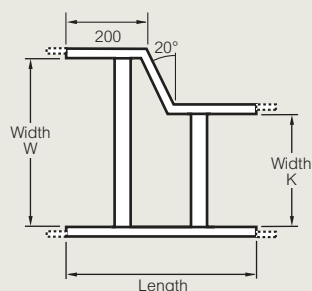

Right hand reducer

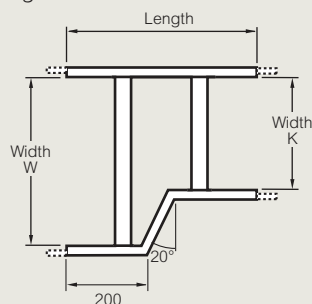

Weights

All weights given are in kilograms (kg) and are for hot dip galvanised G finish

To obtain the appropriate component weight in other finishes, multiply the given weight by the following factors :

- Deep galvanised (D) x 1.07
- Stainless steel (S) x 0.94
- Powder coated (E) x 0.97

■ Rung details

Type 1 rungs are used as standard

Type 2 and 3 are only available to special order, see p. 37
Type 1 can be supplied in any combination to special order

Type 1 standard

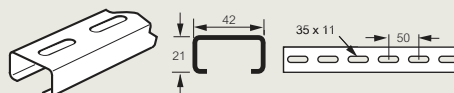

Key : Replace the letter shown in red with your choice from the following options :

- X = Ladder type : Z (Topaz), P (Sapphire), E (Emerald)
- F = Finish : G (hot dip galvanised after manufacture)
 - D (deep galvanised)
 - S (stainless steel)
 - E (powder coated)

All dimensions (mm) are nominal

→ Integral fitting coupler detail : see p. 44

→ Fitting to fitting coupler sets : see p. 45

Swifts® cable ladder supports

heavy duty cantilever arms

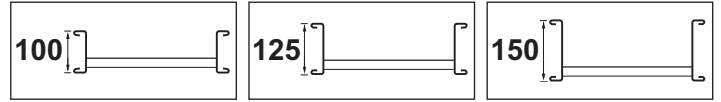

Heavy duty cantilever arms enable horizontal runs of cable ladder to be mounted to vertical steel, concrete or masonry surfaces or to Swiftrack channel. They are suitable for use with all cable ladder ranges and are available in six sizes to accommodate all ladder widths

Cable ladder can be fitted to cantilever arms in two alternative positions without the need for drilling (see below). Appropriate slots are provided to ensure that the arm does not protrude beyond the ladder side rail for safety

Supplied singly without fasteners

Installation (typical)

Normal installation

Using cantilever arm and ladder of equal widths enables the ladder side rail to be positioned close to the vertical wall or support (dimension X)

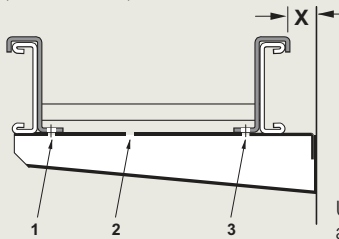

Use slots 1 and 3 for ladder and arm of equal width

Clearance installation

Using cantilever arm one width greater than ladder increases the distance between the ladder side rail and vertical wall (dimension Y). This allows easy access to coupler fasteners and cover clips (if fitted)

Note

If covers are fitted the minimum clearance to the vertical support face (dimension X) must be 30 mm. However, for access to fit cover clips a larger clearance (i.e. dimension Y) is required when the vertical support is a solid face

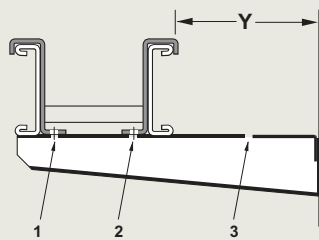

Use slots 1 and 2 for arm one width greater than ladder

Ladder range	X	Y
Topaz	60	210
Sapphire	60	210
Emerald	60	210

Assembly

Fixing cantilever arms to vertical supports

Mounting holes for M12 fasteners are provided in the end plates ; two for 150 mm – 300 mm and three for 450 mm – 900 mm

When fixing to Swiftrack channel use M12 bolts, washers and channel nuts

Fixing ladder to cantilever arms

All heavy duty cantilever arms have slots in the top flange for attaching hold down brackets and slots in the side flanges for attaching bolttable angled hold down brackets

Each bracket can be used exclusively or a combination of both, as required

Insulated hold down brackets can be used to attach ladder to cantilever arms if required

Fixing ladder to cantilever arms (continued)

Hold down brackets

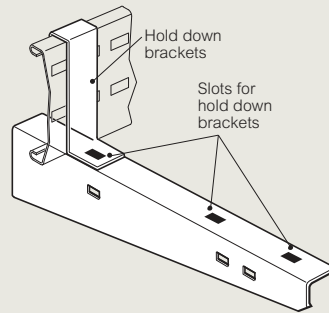

Cat. Nos.	Recommended safe working load kgF ⁽¹⁾	
	Arm fixed to rigid surface	Arm fixed to Swiftrack
HCA 150 F	300	250
HCA 300 F	350	250
HCA 450 F	400	300
HCA 600 F	500	350
HCA 750 F	600	400
HCA 900 F	700	450

(1) Per cantilever arm for load uniformly distributed across the complete arm, when ladder fixed to arm using Swifts hold down brackets, see p. 81. Safety factor : 2

Bolttable angled hold down brackets

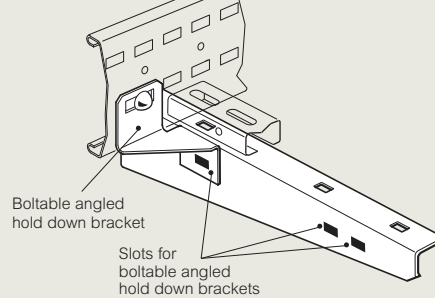

For hold down bracket, see p. 81

For bolttable angled hold down bracket, see p. 83

Dimensions and weights

150 and 300 mm ladder widths

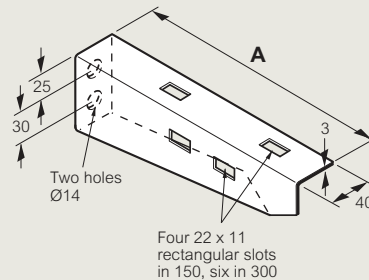

Ladder Width	A	B	Weight (kg)
150	250	–	1.0
300	400	–	1.6
450	550	45	2.5
600	700	95	3.6
750	850	145	4.9
900	1000	195	6.5

450 to 900 mm ladder widths

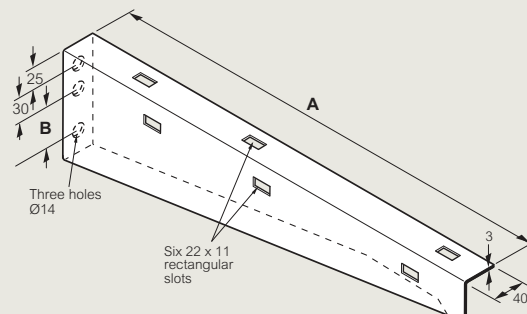

Weights

All weights given are in kilograms (kg) and are for hot dip galvanised G finish

To obtain the appropriate component weight in other finishes, multiply the given weight by the following factors :

- Deep galvanised (D) x 1.07
- Stainless steel (S) x 0.94
- Powder coated (E) x 0.97

All dimensions (mm) are nominal

Key : Replace the letter shown in red with your choice from the following options :

- F = Finish : G (hot dip galvanised after manufacture)
- D (deep galvanised)
- S (stainless steel)
- E (powder coated)

→ Swiftrack channel support : see p. 99–108

→ Hold down brackets : see p. 81

→ Bolttable angled hold down brackets : see p. 83

Swifts® cable ladder supports

heavy duty trapeze hangers

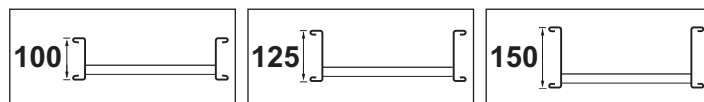

Heavy duty trapeze hangers are suitable for use with all cable ladder ranges. They enable all widths of ladder to be supported from overhead M12 threaded rods hung from ceiling brackets, Swiftrack support system or from beam clamps attached to joists or steel beams. Supplied singly without fasteners.

Installation (typical)

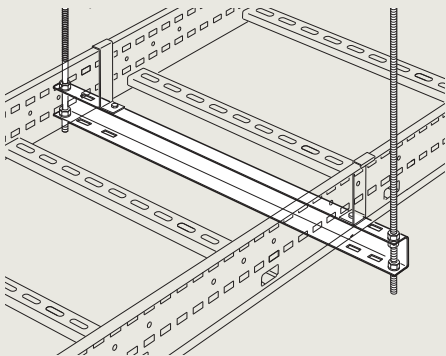

Assembly

Fixing trapeze hangers to threaded rods

There are three alternative methods of fixing trapeze hangers to threaded rods as shown below. The recommended safe working load for each width and method of fixing is given in the table (below)

- A M12 threaded rod
- B M12 nut
- C Washer
- D Upper flange
- E Lower flange

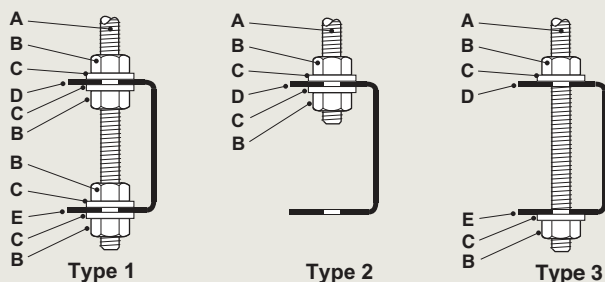

Cat. Nos.	Recommended safe working load kg ⁽¹⁾		
	Type 1	Type 2	Type 3
HTH 150 F	400	240	120
HTH 300 F	400	240	120
HTH 450 F	400	240	120
HTH 600 F	500	300	150
HTH 750 F	500	300	150
HTH 900 F	500	300	150

(1) Per trapeze hanger for load uniformly distributed across complete hanger
Safety factor : 2

Assembly (continued)

Fixing ladder to trapeze hangers

All trapeze hangers are provided with fixing slots correctly positioned to accept any of Swifts hold down brackets or clips without the need for drilling. The slots will accept all cable ladder ranges. Insulated versions of hold down clips and brackets are available, see p. 80-81

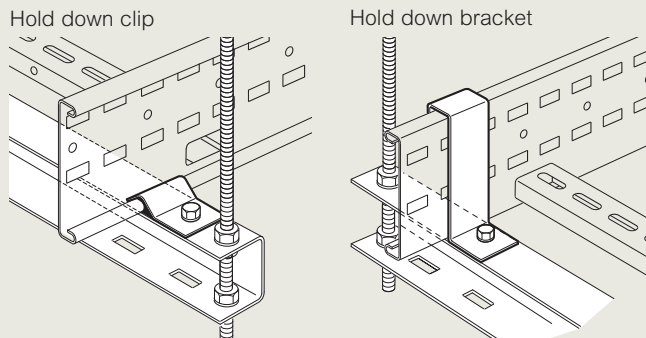

Hold down clip

Hold down bracket

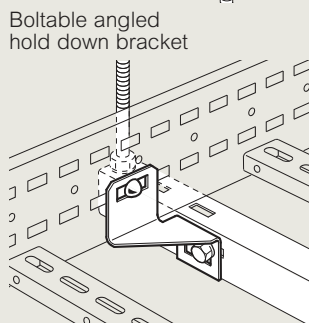

Boltable angled hold down bracket

Dimensions and weights

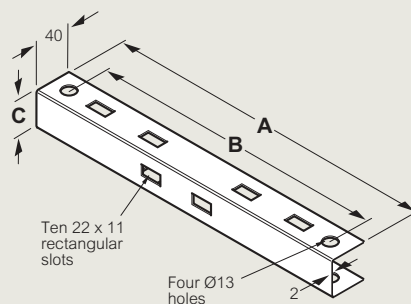

Ladder Width	A	B	C	Rod size	Weight (kg)
150	350	310	40	M12	0.7
300	500	460	40	M12	0.9
450	650	610	50	M12	1.3
600	800	760	60	M12	1.8
750	950	910	70	M12	2.2
900	1100	1060	80	M12	2.8

Weights

All weights given are in kilograms (kg) and are for hot dip galvanised G finish

To obtain the appropriate component weight in other finishes, multiply the given weight by the following factors :

- Deep galvanised (D) x 1.07
- Stainless steel (S) x 0.94
- Powder coated (E) x 0.97

All dimensions (mm) are nominal

- Swiftrack channel support : see p. 99-108
- Hold down clips : see p. 80
- Hold down brackets : see p. 81

Key : Replace the letter shown in red with your choice from the following options :

- F = Finish : G (hot dip galvanised after manufacture)
- D (deep galvanised)
- S (stainless steel)
- E (powder coated)

Swifts® cable ladder supports

hanger rod brackets

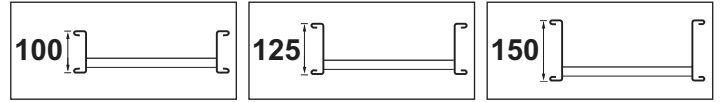

Hanger rod brackets are an effective way of supporting any width of cable ladder off studding without the need for special trapeze hangers or cut lengths of channel. They are particularly useful when space to the sides of a ladder run is restricted or where maximum headroom is required below a ladder run. Hanger rod brackets are available for all ladder ranges and supplied in pairs with bracket to ladder fasteners.

Installation (typical)

Single level installation

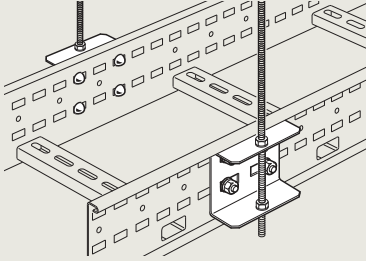

Multiple level installation

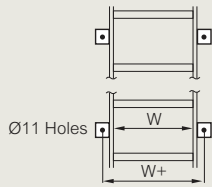
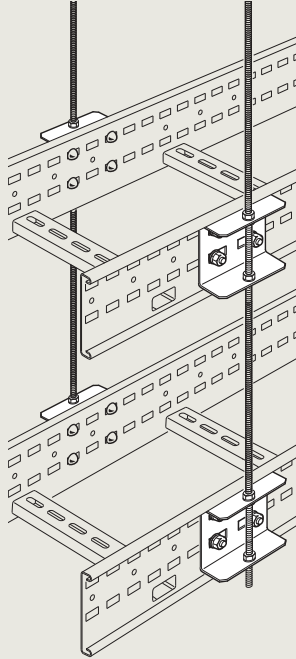

Cat. Nos.	Centre distance between fixing holes
ZRB F	W+66
PRB F	W+66
ERB F	W+66

When hanger rod brackets are fitted to ladder, covers cannot be used

Assembly

Brackets can be used with either M10 or M12 threaded rod

Fixing bracket to ladder

Brackets are fixed directly to the outside of the ladder siderail as shown. The slots in the side rail and the bracket provide sufficient movement to align the bracket with the threaded rod.

Fixing bracket to threaded rod

Four nuts and washers are used to fix each bracket to the threaded rod. This ensures the stability of the support and also optimises the safe working load.

Bracket to ladder fasteners (included)

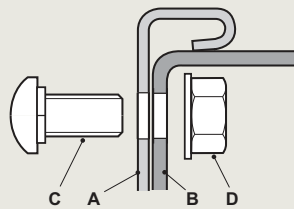

- A Side rail
- B Bracket
- C M10 x 20 coachbolt
- D M10 flange nut

Fastener finishes

For ladders with G, D and E finishes, fasteners are high tensile Grade 8.8 hot dip galvanised.

For ladders with S finish, fasteners are corrosion resistant stainless Grade A470.

For ladders with E finish, the fasteners are Grade 8.8 hot dip galvanised. An alternative material for fasteners may be required depending on the installation environment – contact us on +44 (0) 845 605 4333.

Key : Replace the letter shown in red with your choice from the following options :

- F** = Finish : **G** (hot dip galvanised after manufacture)
- D** (deep galvanised)
- S** (stainless steel)
- E** (powder coated)

Assembly (continued)

Bracket to threaded rod fasteners (not included)

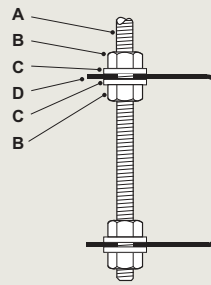

- A M10 or M12 threaded rod
- B Hanger rod bracket
- C M10 or M12 form A washer
- D M10 or M12 nut

Cat. Nos.	Ladder range		
	Topaz	Sapphire	Emerald
ZRB F	PRB F	ERB F	
Quantity of fasteners per bracket	4	4	4

Dimensions and weights

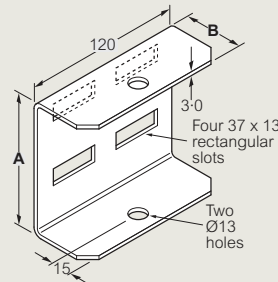

Cat. Nos.	A	B	Weight (kg)
ZRB F	80	48	0.9
PRB F	104	48	1.0
ERB F	127	48	1.1

Weights

All weights given are in kilograms (kg) and are for a pair of brackets in hot dip galvanised G finish.

To obtain the appropriate component weight in other finishes, multiply the given weight by the following factors :

- Deep galvanised (D) x 1.07
- Stainless steel (S) x 0.94
- Powder coated (E) x 0.97

Safe working loads

The safe working load of all brackets is 400kg per pair of brackets. When several levels of ladder are mounted on the same threaded rods in a multiple level installation, it is important to ensure that the total load on any pair of rods does not exceed the safe working load of the rods or their attachment points.

All dimensions (mm) are nominal

Swifts® cable ladder supports

wall support brackets

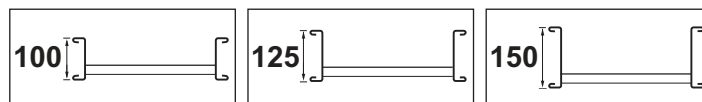

Wall support brackets are an effective way of fixing any width of ladder, running either vertically or horizontally, to a vertical support. These brackets can be mounted onto Swiftrack channel, structural steelwork or directly to a wall using M10 bolts (not included). Wall support brackets are available for all ladder ranges and supplied in pairs with bracket to ladder fasteners.

Installation (typical)

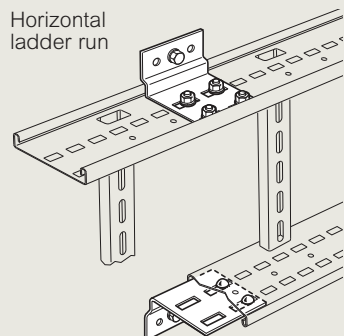

Horizontal ladder run

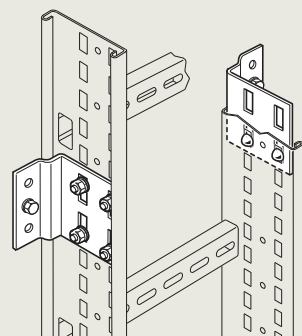

Cat. Nos.	Centre distance between fixing holes
ZRB F	W + 106
PRB F	W + 106
ERB F	W + 106

Assembly

Holes are provided for M10 setscrews – length and finish to suit application.

Fixing brackets to supports

Only one fastener is needed to attach each bracket to its support; three attachment holes are provided to give flexibility when positioning the ladder run.

Fixing brackets to ladder – vertical runs

When installing ladder runs vertically, the full quantity of fasteners must be used to attach each bracket to the ladder.

Fixing brackets to ladder – horizontal runs

When installing ladder runs horizontally it is often easiest to mount the lower brackets to the support, lift the ladder into position then mount the upper brackets. This procedure is especially useful for single person installation.

Assembly (continued)

Bracket to ladder fasteners (included)

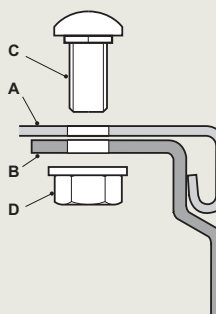

- A Side rail
- B Bracket
- C M10 x 20 coachbolt
- D M10 flange nut

Fastener finishes

For ladders with G, D and E finishes, fasteners are high tensile Grade 8.8 hot dip galvanised.

For ladders with S finish, fasteners are corrosion resistant stainless Grade A470.

An alternative material for fasteners may be required depending on the installation environment – contact us on +44 (0) 845 605 4333.

Cat. Nos.	Ladder range		
	Topaz	Sapphire	Emerald
	ZWSB F	PWSB F	EWSB F
Quantity of fasteners per bracket	4	4	4

Dimensions and weights

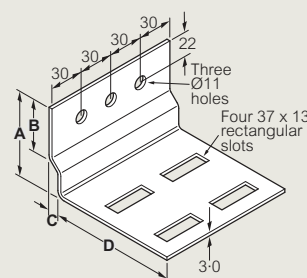

Cat. Nos.	A	B	C	D	Weight (kg)
ZWSB F	75	42	9.0	86.0	0.8
PWSB F	75	42	9.0	111.0	1.0
EWSB F	75	42	9.0	123.5	1.0

Weights

All weights given are in kilograms (kg) and are for a pair of brackets in hot dip galvanised G finish.

To obtain the appropriate component weight in other finishes, multiply the given weight by the following factors:

- Deep galvanised (D) x 1.07
- Stainless steel (S) x 0.94
- Powder coated (E) x 0.97

Safe working loads

Vertical ladder runs

For a vertically mounted ladder installation, the maximum safe working load is 300 kg per pair of wall support brackets.

Horizontal ladder runs

For a horizontally mounted ladder installation, the wall support brackets should be pitched at 2-3 m intervals so that the limiting factor for safe working load is the span between brackets and the ladder width rather than the brackets.

Key : Replace the letter shown in red with your choice from the following options :

- F = Finish : G (hot dip galvanised after manufacture)
- D (deep galvanised)
- S (stainless steel)
- E (powder coated)

All dimensions (mm) are nominal.

➔ Swiftrack channel support : see p. 99-108

Swifts® cable ladder supports

90° end connectors

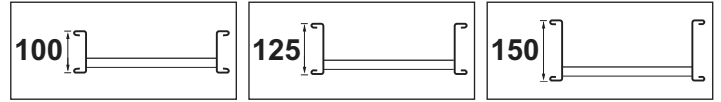

90° end connectors are used to fix the end of a cable ladder run to a vertical surface (steel, concrete or masonry)
Supplied in pairs with bracket to ladder fasteners

Installation (typical)

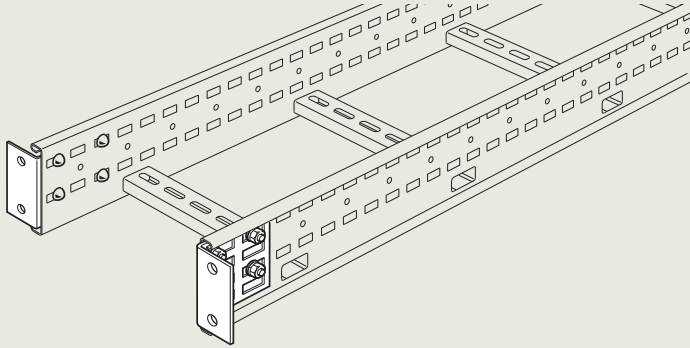

Cat. Nos.	Ladder range		
	Topaz	Sapphire	Emerald
Quantity of fasteners per bracket	4	4	4

Assembly

Connector to ladder fasteners (included)

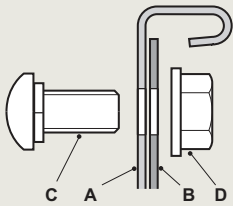

- A Side rail
- B Bracket
- C M10 x 20 coachbolt
- D M10 flange nut

Fastener finishes

For ladders with G, D and E finishes, fasteners are high tensile Grade 8.8 hot dip galvanised
For ladders with S finish, fasteners are corrosion resistant stainless Grade A470
An alternative material for fasteners may be required depending on the installation environment - contact us on +44 (0) 845 605 4333

Dimensions and weights

Medium duty (Topaz) ZB F

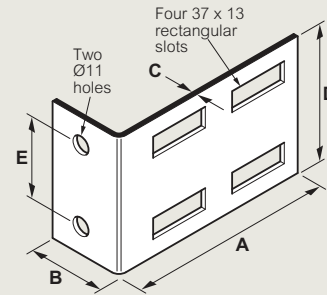

Heavy duty (Sapphire) PB F and extra heavy duty (Emerald) EB F

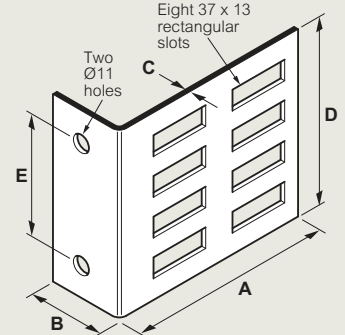

Cat. Nos.	A	B	C	D	E	Weight (kg)
ZB F	127	47	1.5	84	50	0.3
PB F	127	47	2.0	115	75	0.5
EB F	127	47	2.0	140	75	0.7

Weights

All weights given are in kilograms (kg) and are for a pair of connectors in hot dip galvanised G finish

To obtain the appropriate component weight in other finishes, multiply the given weight by the following factors :

- Deep galvanised (D) x 1.07
- Stainless steel (S) x 0.94
- Powder coated (E) x 0.97

Key : Replace the letter shown in red with your choice from the following options :

- F = Finish : G (hot dip galvanised after manufacture)
- D (deep galvanised)
- S (stainless steel)
- E (powder coated)

All dimensions (mm) are nominal

Swifts® cable ladder ancillary items

earth continuity connector

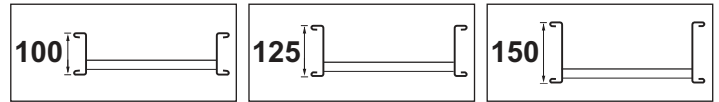

If a supplementary bonding conductor for equipotential earthing is required, straight lengths and fittings in all Swifts ladder ranges have fixing holes provided to accommodate a flexible earth continuity connector. On straight lengths, fixing holes are pitched every 75 mm to avoid the need for drilling if the ladder is cut. When used with galvanised or stainless steel finish ladder, the lug of the earth continuity connector is fixed directly to the ladder side rail. Finish : electro tinned copper. The earth continuity connector has a current capacity rating of 100 Amps. Supplied in bagged quantities of ten with fasteners.

■ Installation (typical)

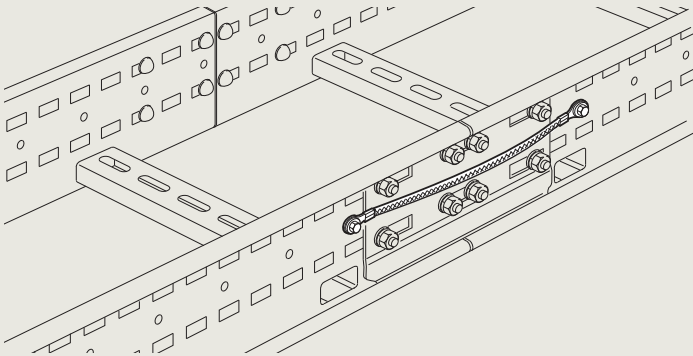

■ Assembly

Typical ladder length ends

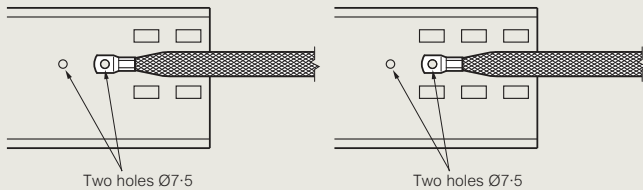

Attach the earth continuity connector to either hole, depending on coupler position.

Fasteners (included)

Two fasteners per connector

G, D, S and E finishes

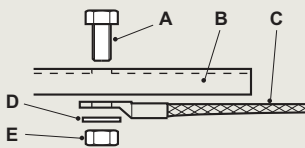

- A M6 x 10 Brass setscrew (BS 3692)
- B Ladder side rail
- C Earth continuity connector
- D Brass form A washer 1.6 x 12.5 x 6.4 (BS4320)
- E M6 Brass nut (BS 3692)

■ Dimensions

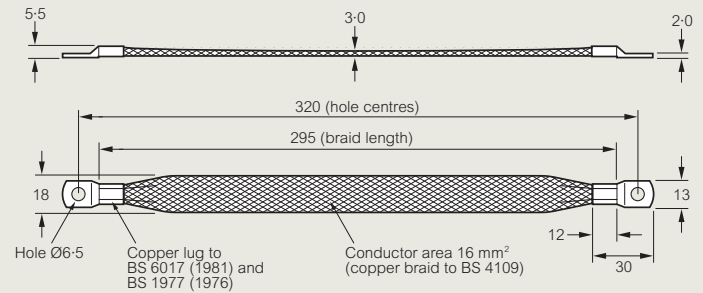

Key : Replace the letter shown in red with your choice from the following options :

- F = Finish : **G** (hot dip galvanised after manufacture)
- D** (deep galvanised)
- S** (stainless steel)
- E** (powder coated)

All dimensions (mm) are nominal

Swifts® cable ladder ancillary items

hold down clips and insulated hold down clips

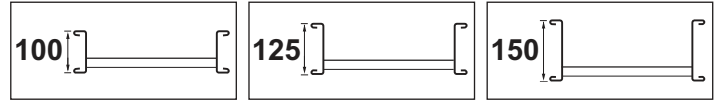

Hold down clips are used for fixing cable ladder to trapeze hangers, Swiftrack channel or other flat support surfaces. They are fitted on the outside of the ladder rail.
 Supplied singly without fasteners
 Supplied with the required nylon insulating pad, bush and washer
 Insulated versions for stainless steel ladder are available on request, for details contact us on +44 (0) 845 605 4333

	Ladder range Cat. Nos.		
	Topaz	Sapphire	Emerald
Standard hold down clip	ZFF	PFF	EFF
Insulated hold down clip	ZF INF	PF INF	EF INF

Installation (typical)

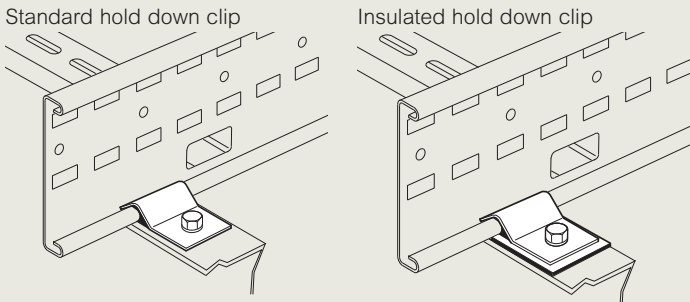

Assembly

Insulated hold down clips are assembled as shown (typical) with the nylon pad, bush and washer providing the required insulation
 Standard hold down clips are assembled in the same way, but without the insulating parts (bold type – see below)
 Use M10 screw, nut and washers to suit the application (not included)
 Use fasteners illustrated – only those shown in bold type are included

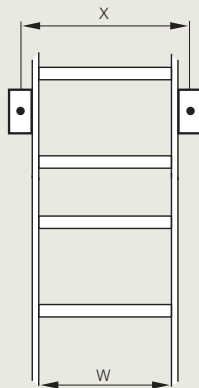
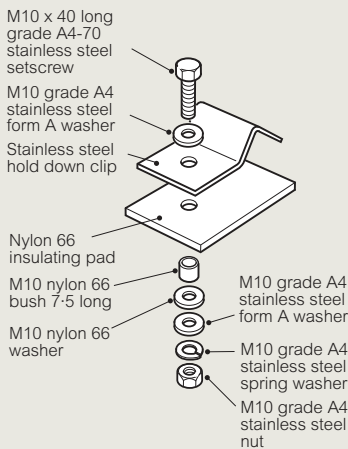

Fixing hold down clips to supports

All types of support from the Swifts range are provided with correctly positioned fixing holes to accept hold down clips without drilling. The table contains data on fixing hole spacing required when attaching hold down clips to other supports

Cat. Nos.	Centre distance between fixing holes X
ZFF	W + 95
PFF	W + 95
EFF	W + 95

W = ladder width

Key : Replace the letter shown in red with your choice from the following options :

- F** = Finish : **G** (hot dip galvanised after manufacture)
- D** (deep galvanised)
- S** (stainless steel)
- E** (powder coated)

Assembly (continued)

Standard hold down clip

Insulated hold down clip

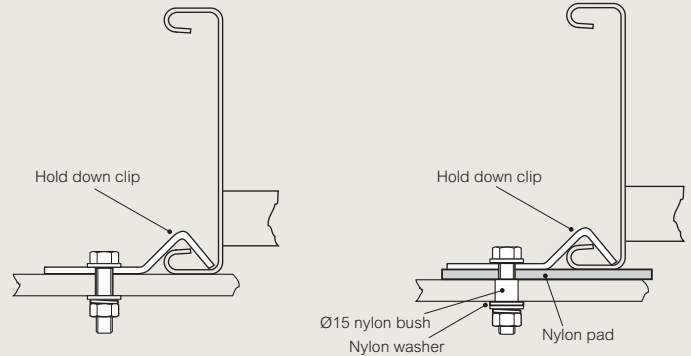

Dimensions and weights

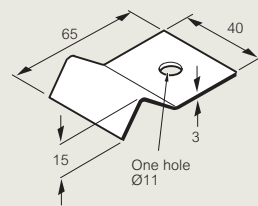

Cat. Nos.	Weight (kg)
ZFF	0.069
PFF	0.069
EFF	0.069

Weights

All weights given are in kilograms (kg) and are for hot dip galvanised G finish

To obtain the appropriate component weight in other finishes, multiply the given weight by the following factors :

- Deep galvanised (D) x 1.07
- Stainless steel (S) x 0.94
- Powder coated (E) x 0.97

All dimensions (mm) are nominal

→ Trapeze hangers : see p. 75

→ Swiftrack channel support : see p. 99-108

Swifts® cable ladder ancillary items

hold down brackets and insulated hold down brackets

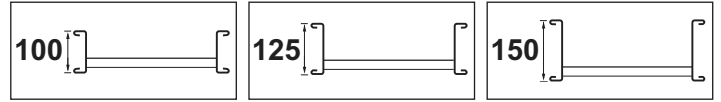

Hold down brackets are used for fixing cable ladder to cantilever arms, trapeze hangers, Swiftrack channel or other flat support surfaces. They can be fitted on the inside or the outside of the ladder rail

When used with other items from the Swifts range refer to the relevant product page for specific orientation details

Supplied singly without fasteners

Insulated versions for stainless steel ladder are available, contact us on +44 (0) 845 605 4333

Insulated hold down brackets are supplied with the required nylon insulating pad, bush and washer

Installation (typical)

Standard hold down bracket

Insulated hold down bracket

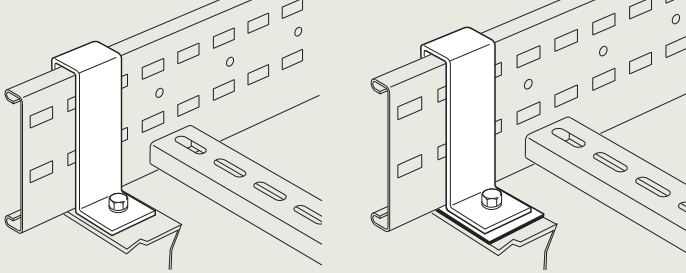

	Ladder range		
	Topaz	Sapphire	Emerald
Standard hold down bracket	ZJF	PJF	EJF
Insulated hold down bracket	ZJ INF	PJ INF	EJ INF

Assembly

Insulated hold down brackets are assembled as shown (typical) with the nylon pad, bush and washer providing the required insulation.

Standard hold down brackets are assembled in the same way, but without the insulating parts (bold type – see below)

Use M10 screw, nut and washers to suit the application (not included)

Use fasteners illustrated – only those shown in bold type are included

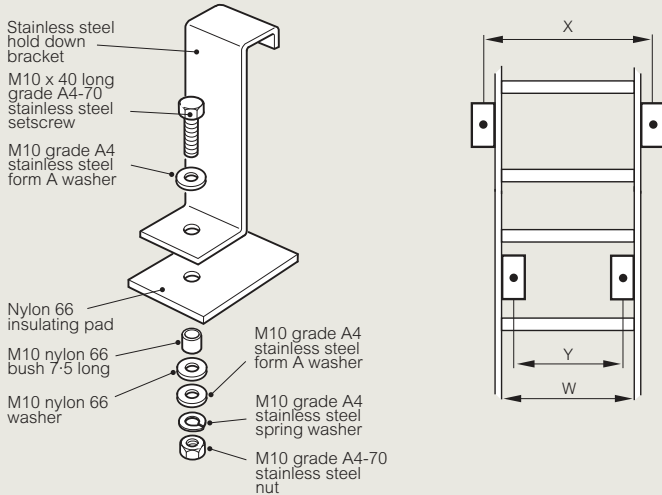

Fixing hold down brackets to supports

All types of support from the Swifts range are provided with correctly positioned fixing holes to accept hold down brackets without drilling. The table contains data on fixing hole spacing required when attaching hold down brackets to other supports

Cat. Nos.	Centre distance between fixing holes	
	inside ladder Y	outside ladder X
ZJF	W - 44	W + 80
PJF	W - 44	W + 80
EJF	W - 44	W + 80

W = ladder width

Key : Replace the letter shown in red with your choice from the following options :

- F** = Finish : **G** (hot dip galvanised after manufacture)
- D** (deep galvanised)
- S** (stainless steel)
- E** (powder coated)

Assembly

Standard hold down bracket

Insulated hold down bracket

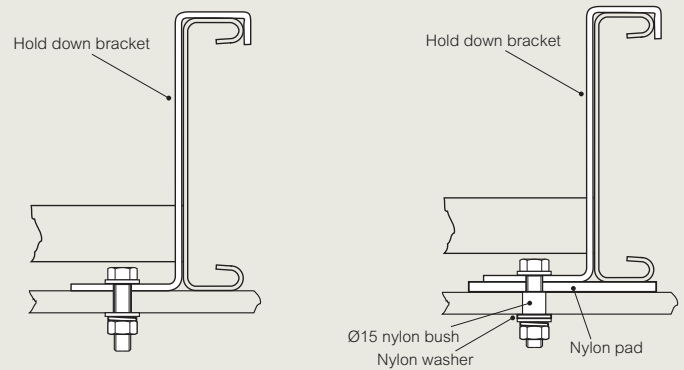

Dimensions and weights

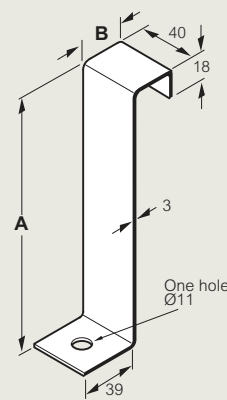

Cat. Nos.	A	B	Weight (kg)
ZJF	103	31	0.16
PJF	128	31	0.19
EJF	153	31	0.22

Weights

All weights given are in kilograms (kg) and are for hot dip galvanised G finish

To obtain the appropriate component weight in other finishes, multiply the given weight by the following factors :

Deep galvanised (D) x 1.07

Stainless steel (S) x 0.94

Powder coated (E) x 0.97

All dimensions (mm) are nominal

→ Cantilever arms : see p. 74

→ Swiftrack channel support : see p. 99-108

Swifts® cable ladder ancillary items

boltable hold down brackets

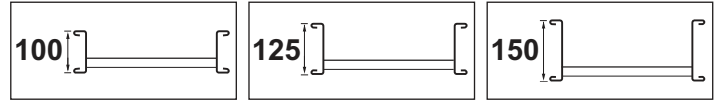

Boltable hold down brackets enable all ranges of cable ladder to be secured to either Swiftrack or fabricated structural steel supports. Brackets can be fitted wherever supports are available along the length of the ladder and fit to the inside of the ladder side rails thus minimising the total width required. Supplied singly with bracket to ladder fasteners.

■ Installation (typical)

Support between rungs

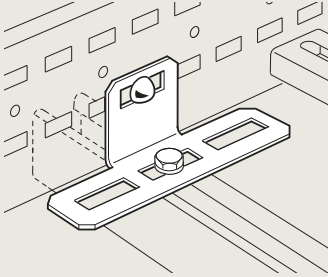

Support under rungs

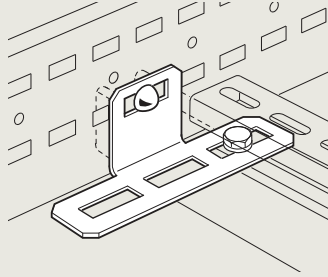

■ Assembly

When attaching boltable hold down brackets to fabricated structural steel supports, the spacing between fixing holes should be $W - 64$ mm, where W is the ladder width.

Bracket to ladder fasteners (included)

Cat. Nos.	Ladder range		
	Topaz	Sapphire	Emerald
ZNF	PNF	ENF	
Quantity of fasteners per bracket	1	1	1

M10 x 20 coachbolt
M10 flange nut

Fastener finishes

For ladders with G, D and E finishes, fasteners are high tensile Grade 8.8 hot dip galvanised.

For ladders with S finish, fasteners are corrosion resistant stainless Grade A470.

An alternative material for fasteners may be required depending on the installation environment, for details contact us on +44 (0) 845 605 4333.

Bracket to support fasteners (not included)

Slots are provided for M10 setscrews – length to suit application.

■ Dimensions and weights

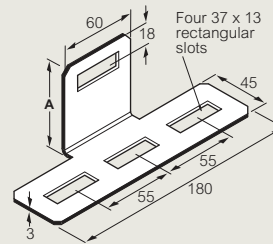

Cat. Nos.	A	Weight (kg)
ZNF	43.0	0.1
PNF	68.5	0.2
ENF	80.5	0.3

Weights

All weights given are in kilograms (kg) and are for hot dip galvanised G finish.

To obtain the appropriate component weight in other finishes, multiply the given weight by the following factors:

Deep galvanised	(D) x 1.07
Stainless steel	(S) x 0.94
Powder coated	(E) x 0.97

Key : Replace the letter shown in red with your choice from the following options :

F = Finish : **G** (hot dip galvanised after manufacture)
D (deep galvanised)
S (stainless steel)
E (powder coated)

All dimensions (mm) are nominal.

Swifts® cable ladder ancillary items

boltable angled hold down brackets

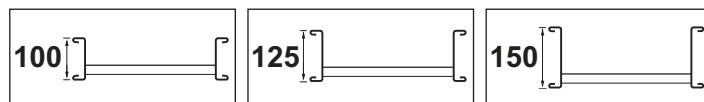

Boltable angled hold down brackets enable the Swifts ranges of cable ladder to be secured to Swifts heavy duty cantilever arms and trapeze hangers. Brackets can be fitted wherever supports are available along the length of the ladder and fit to the inside of the ladder side rails thus minimising the total width required

Boltable angled hold down brackets are supplied in handed pairs with bracket to ladder fasteners

For fixing cable ladder to Swiftrack channel or structural steel supports use boltable hold down bracket, see p. 82

■ Installation (typical)

Cantilever arm between rungs

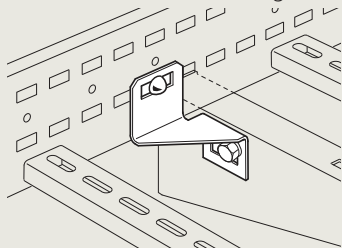

Trapeze hanger between rungs

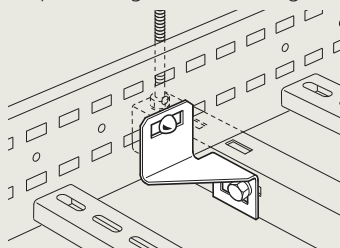

Trapeze hanger under rung (1)

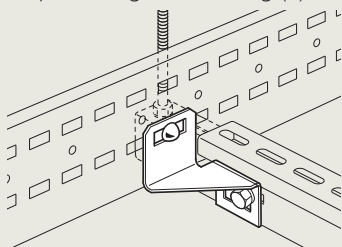

Trapeze hanger under rung (2)

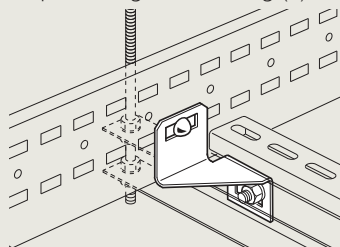

■ Assembly

Bracket to ladder fasteners (included)

Cat. Nos.	Ladder range		
	Topaz	Sapphire	Emerald
ZPF	PPF	EPF	
Quantity of fasteners per bracket	1	1	1

M10 x 20 coachbolt

M10 flange nut

Fastener finishes

For ladders with G, D and E finishes, fasteners are high tensile Grade 8.8 hot dip galvanised

For ladders with S finish, fasteners are corrosion resistant stainless Grade A470

An alternative material for fasteners may be required depending on the installation environment, for details contact us on +44 (0) 845 605 4333

Bracket to support fasteners (not included)

Slots are provided for M10 setscrews – length to suit application

■ Dimensions and weights

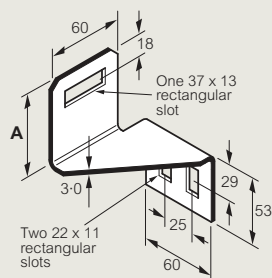

Cat. Nos.	A	Weight (kg)
ZPF	43.0	0.4
PPF	68.0	0.4
EPF	80.5	0.6

Weights

All weights given are in kilograms (kg) and are for a pair of brackets in hot dip galvanised G finish

To obtain the appropriate component weight in other finishes, multiply the given weight by the following factors :

Deep galvanised (D) x 1.07

Stainless steel (S) x 0.94

Powder coated (E) x 0.97

Key : Replace the letter shown in red with your choice from the following options :

F = Finish : G (hot dip galvanised after manufacture)

D (deep galvanised)

S (stainless steel)

E (powder coated)

All dimensions (mm) are nominal

→ Cantilever arms : see p. 74

→ Trapeze hangers : see p. 75

Swifts® cable ladder ancillary items

straight and curved dividers

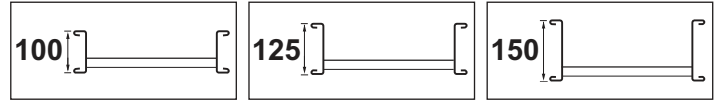

Straight dividers are used, along with curved dividers, to physically separate different types or groups of cable within one cable ladder run. Straight dividers are supplied in 3 m lengths with fasteners. Curved dividers are supplied in 1 m lengths with fasteners. Straight dividers with G finish are for use on ladder runs with G or D finishes. Curved dividers with G finish are for use on ladder runs with G or D finishes.

Installation (typical)

Straight divider

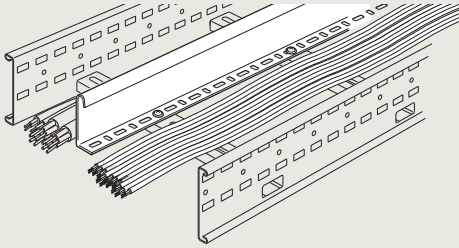

Curved divider

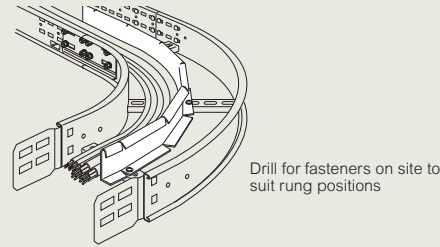

Assembly

Fasteners for straight dividers (included)

G and E finish dividers

M6 x 12 roofing bolt
M6 nut
M6 roofing washers (2 off)

S finish dividers

M6 x 12 pan head screw
M6 form A washer
M6 square washer
M6 nut

Cat. Nos.	Ladder range		
	Topaz	Sapphire	Emerald
ZDVF	PDVF	EDVF	
Quantity of fasteners per 3.0 m length	10	10	10

Fastener finishes

For ladders with G and D finishes, fasteners are galvanised or zinc plated.

For ladders with S finish, fasteners are corrosion resistant stainless Grade A470.

For ladders with E finish, the choice of material for fasteners will depend on the installation environment - contact us on +44 (0) 845 605 4333.

Assembly (continued)

Fasteners for curved dividers (included)

G and E finish dividers

M6 x 12 roofing bolt
M6 nut
M6 roofing washers (2 off)

S finish dividers

M6 x 12 pan head screw
M6 form A washer
M6 square washer
M6 nut

Cat. Nos.	Ladder range		
	Topaz	Sapphire	Emerald
ZCURF	PCURF	ECURF	
Quantity of fasteners per 1.0 m length	4	4	4

Fastener finishes

For ladders with G and D finishes, fasteners are galvanised or zinc plated.

For ladders with S finish, fasteners are corrosion resistant stainless Grade A470.

For ladders with E finish, the choice of material for fasteners will depend on the installation environment - contact us on +44 (0) 845 605 4333.

Dimensions and weights

For use with all ladder types of G, D, S and E finishes.

Straight divider

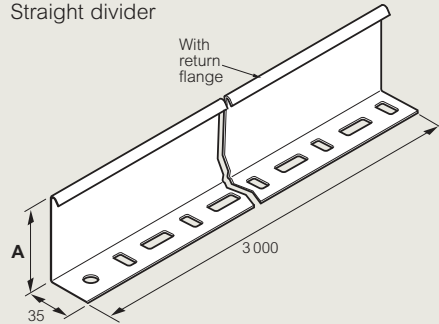

Cat. Nos.	A	Weight (kg) Finish		
		G	S	E
ZDVF	68	2.7	2.5	2.6
PDVF	93	4.0	3.7	3.9
EDVF	118	4.7	4.4	4.5

Curved divider

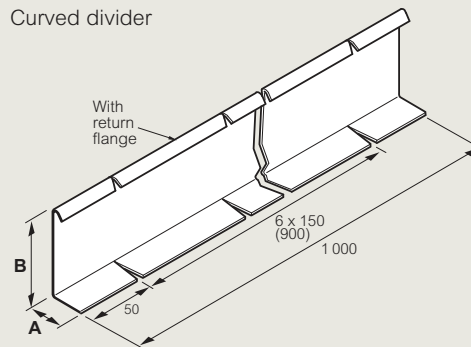

Cat. Nos.	A Finish G and S	B	Weight (kg) Finish		
			G	S	E
ZCURF	25	68	1.1	1.0	1.0
PCURF	25	93	1.3	1.2	1.2
ECURF	25	118	1.6	1.5	1.5

Key : Replace the letter shown in red with your choice from the following options :

F = Finish : **G** (hot dip galvanised after manufacture)
S (stainless steel)
E (powder coated)

All dimensions (mm) are nominal

Swifts® cable ladder ancillary items

articulated risers

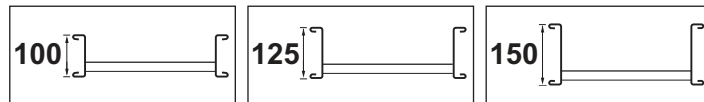

One or more articulated riser sets can be used to solve most misalignment problems on site or can be used to form risers. Each set comprises three articulated riser sections, and the necessary vertical hinged connectors with fasteners. Connect together to form pre-set angles or pre-assembled for adjustment on site using the holes / slots shown.

Installation (typical)

Articulated riser set bridging obstructions on site

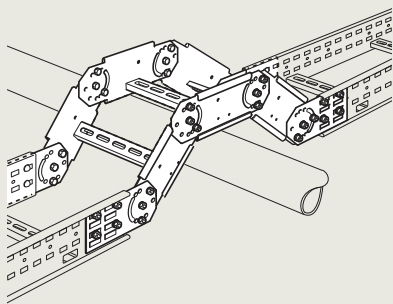

Two articulated riser sections used as a riser

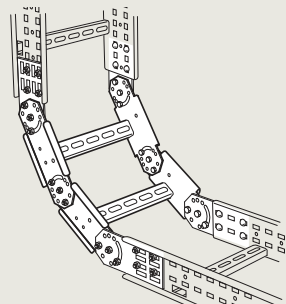

Rigid support for the cable ladder should be provided on both sides adjacent to each vertical hinged connector joint.

Assembly

Pre-set angles and radii

The diagrams below show the number of articulated riser sections needed to form a given angle and radius.

- Identify the correct fixing holes.
- Stand each component part on its side in its assembled position, overlapping the joint alternately. At every upper joint insert a fastener through the identified outer holes but do not fully tighten. Do not insert fasteners through the centre hole first, this makes identification of the outer holes very difficult.
- Adjust the assembly to align the centre holes of each joint. Fit fasteners but do not fully tighten.
- At each joint, insert a third fastener through the slot and corresponding hole.
- Tighten all fasteners.
- Turn the whole assembly over and repeat steps 1 to 5.

Section required for a given angle

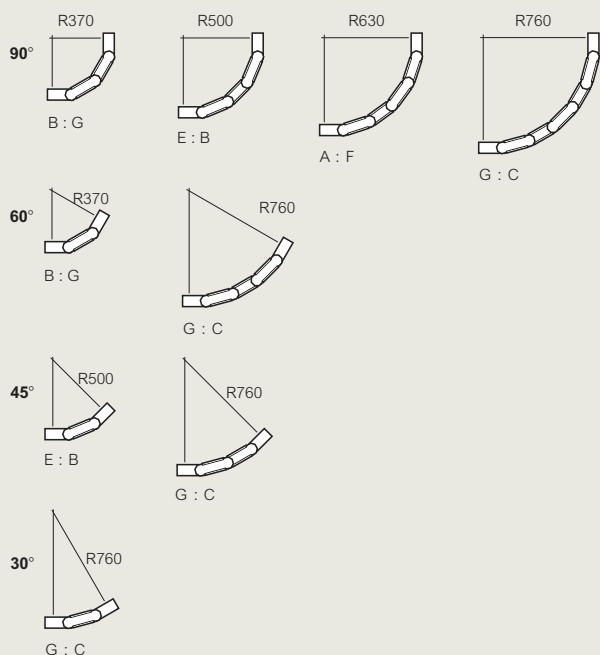

Key : Replace the letter shown in red with your choice from the following options :

- F = Finish : G (hot dip galvanised after manufacture)
- D (deep galvanised)
- S (stainless steel)
- E (powder coated)

Assembly (continued)

Pre-assembly for adjustment in-situ

- Lay out the required number of articulated riser sections and vertical hinged connectors, overlapping each joint alternately as shown above.
- At each joint align the centre holes in each component and insert a fastener sufficiently tight to hold the assembly together and carry it to the installation position.
- Fit the vertical hinged connectors to the ladder, see p. 42.
- Adjust the position of each section until the desired path is achieved and tighten the centre fastener at each joint.
- Insert two additional fasteners at each joint and tighten all fasteners.

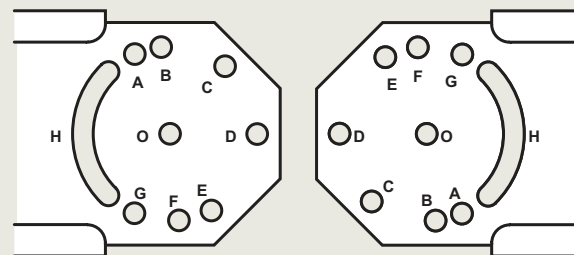

Cat. Nos.	Weight (kg)				
	15°	18°	22.5°	30°	45°
ZARF, PARF, EARF	G : C	A : F	E : B	B : G	F : C

Fasteners (included)

Medium duty (Topaz) ZAR

Heavy duty (Sapphire) PAR
Extra heavy duty (Emerald) EAR

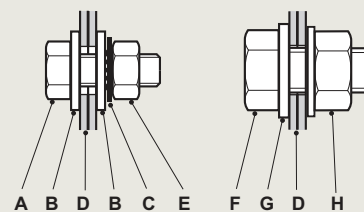

- A M6 x 16 setscrews
- B M6 washer
- C M6 shakeproof washer
- D Connector
- E M6 nut
- F M10 x 20 setscrews
- G M10 form A washer
- H Flange nut

Recommended Torque

Setting (M10): 40Nm

Fastener finishes

For ladders with G and D finishes, fasteners are galvanised or zinc plated. For ladders with S finish, fasteners are corrosion resistant stainless Grade A470.

For ladders with E finish, the choice of material for fasteners will depend on the installation environment - contact us on +44 (0) 845 605 4333.

Cat. Nos.	Ladder range		
	Topaz	Sapphire	Emerald
ZARF	PARF	EARF	
Quantity of fasteners per riser to riser joint	3 x M6	3 x M10	3 x M10

For quantity of fasteners for vertical hinged connectors, see p. 42.

All dimensions (mm) are nominal.

➔ Vertical hinged connectors : see p. 42

Swifts® cable ladder ancillary items articulated risers (continued)

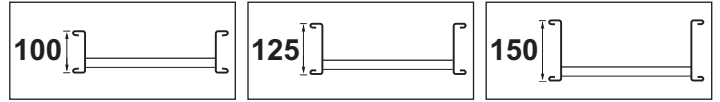

■ Dimensions and weights

Medium duty
(Topaz) ZAR

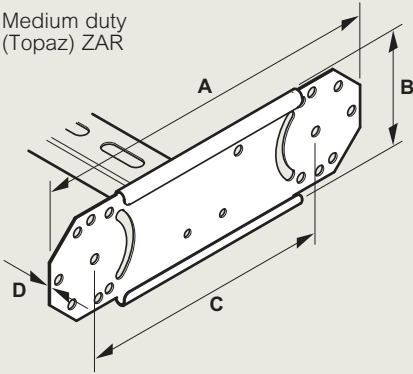

Heavy duty
(Sapphire) PAR

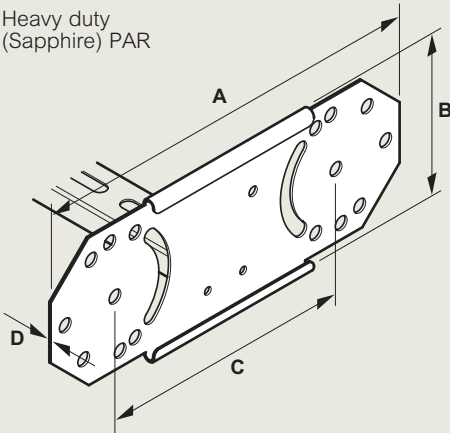

Extra heavy duty
(Emerald) EAR

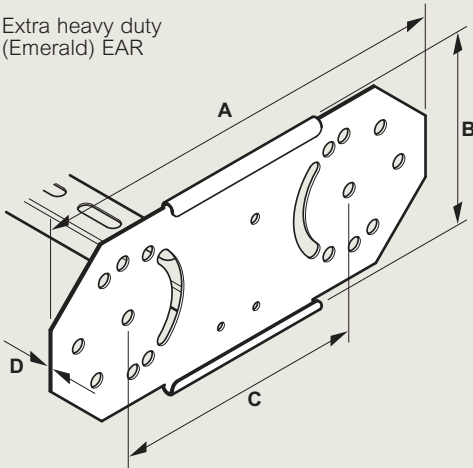

Cat. Nos.	Dimensions (mm)			
	A	B	C	D
ZAR F	280	90	200	1.5
PAR F	315	127	200	2.0
EAR F	338	150	200	2.0

Key : Replace the letter shown in red with your choice from the following options :

- F** = Finish : **G** (hot dip galvanised after manufacture)
- D** (deep galvanised)
- S** (stainless steel)
- E** (powder coated)

■ Dimensions and weights (continued)

Weights

All weights given are in kilograms (kg) and are for a single articulated riser section in a hot dip galvanised G finish

To obtain the appropriate component weight in other finishes, multiply the given weight by the following factors :

- Deep galvanised (D) x 1.07
- Stainless steel (S) x 0.94
- Powder coated (E) x 0.97

Cat. Nos.	150	300	Weight (kg)			
			450	600	750	900
ZAR F	0.8	1.0	1.1	1.3	1.6	1.8
PAR F	1.5	1.6	1.8	1.9	2.2	2.4
EAR F	1.8	2.0	2.1	2.3	2.6	2.8

Swifts® cable ladder ancillary items

dropout plates

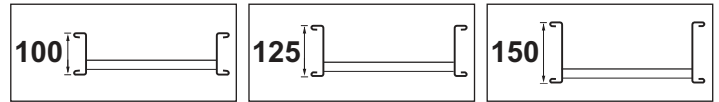

Dropout plates are designed to provide local support to cables as they exit a cable ladder run by passing between the rungs. Supplied singly with fasteners.

■ Installation (typical)

Cat. No. DOWF

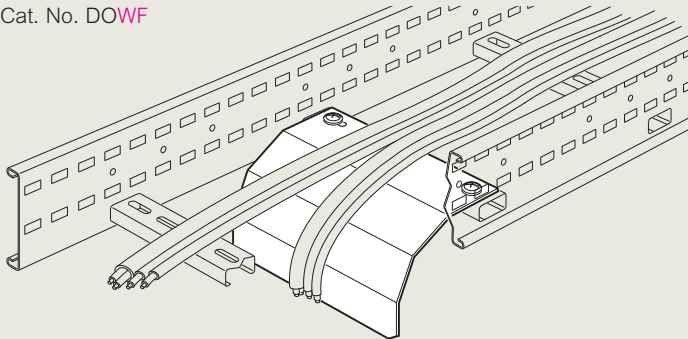

■ Assembly

Fasteners (included)

Two fasteners per plate up to 450 mm wide
Three fasteners per plate 600 mm wide and above

G and D finishes

M6 x 12 roofing bolt
M6 roofing washers (2 off)
M6 nut

S finish

M6 x 12 pan head screw
M6 form A washer
M6 square washer
M6 nut

Fastener finishes

For ladders with G and D finishes, fasteners are galvanised or zinc plated. For ladders with S finish, fasteners are corrosion resistant stainless Grade A470

For ladders with E finish, the choice of material for fasteners will depend on the installation environment - contact us on +44 (0) 845 605 4333

■ Dimensions and weights

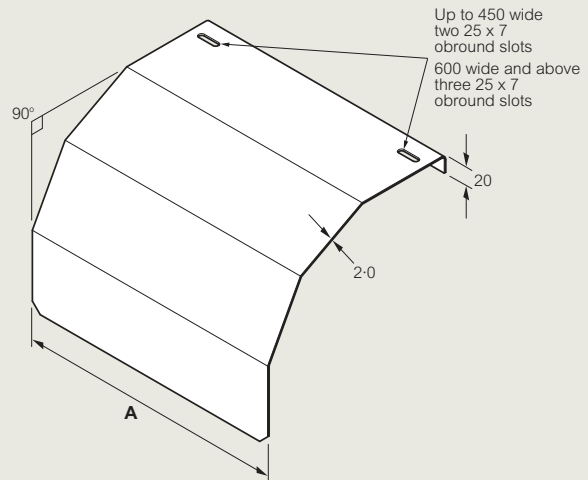

Ladder width (w)	A	Weight (kg)
150	130	0.8
300	280	1.7
450	430	2.7
600	580	3.6
750	790	4.5
900	880	5.5

Weights

All weights given are in kilograms (kg) and are for hot dip galvanised G finish

To obtain the appropriate component weight in other finishes, multiply the given weight by the following factors :

Deep galvanised (D) x 1.07
Stainless steel (S) x 0.94
Powder coated (E) x 0.97

Key : Replace the letter shown in red with your choice from the following options :

W = Width (mm) 150, 300, 450, 600, 750, 900

F = Finish : G (hot dip galvanised after manufacture)

D (deep galvanised)

S (stainless steel)

E (powder coated)

All dimensions (mm) are nominal

Swifts® cable ladder ancillary items

rail to rail dropout brackets

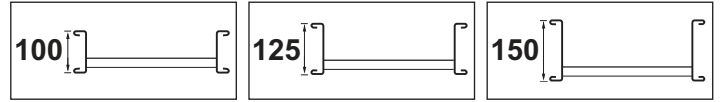

Rail to rail dropout brackets are used to attach a vertical cable ladder run beneath a horizontal main ladder run of the same width, or to attach a vertical cable tray run beneath one side rail of a horizontal main ladder run
Supplied in pairs with fasteners

■ Installation (typical)

Cat. No. MF

Ladder to ladder connection

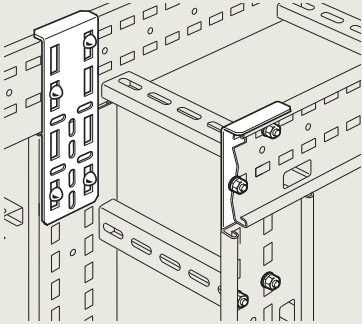

Tray to ladder connection

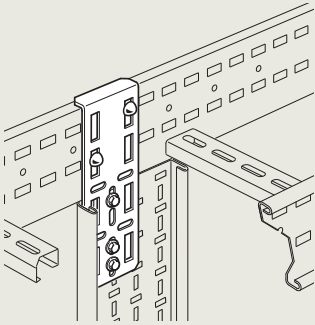

■ Assembly

Note

Unless the connecting vertical ladder or tray is properly supported at a lower position it must be considered as a point load imposed on the main ladder run, any implications of which must be properly considered

Bracket to ladder fasteners (included)

Recommended Torque Setting (M10): 40Nm

Five fasteners per bracket
M10 x 20 coach bolt
M10 flange nut

Fastener finishes

For ladders with G and D finishes, fasteners are galvanised or zinc plated. For ladders with S finish, fasteners are corrosion resistant stainless Grade A470

For ladders with E finish, the choice of material for fasteners will depend on the installation environment - contact us on +44 (0) 845 605 4333

Bracket to tray fasteners (not included)

M6 nuts and bolts (roofing or pan head)

■ Dimensions and weights

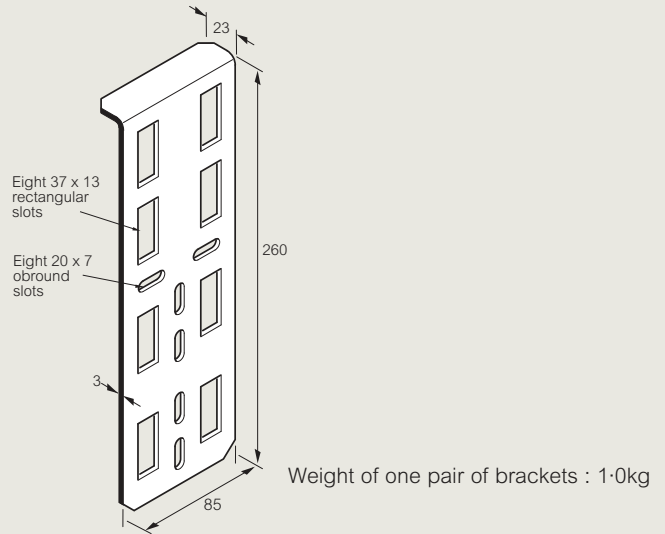

Weights

All weights given are in kilograms (kg) and are for a pair of brackets in hot dip galvanised G finish

To obtain the appropriate component weight in other finishes, multiply the given weight by the following factors :

Deep galvanised	(D) x 1.07
Stainless steel	(S) x 0.94
Powder coated	(E) x 0.97

Key : Replace the letter shown in red with your choice from the following options :

F = Finish : **G** (hot dip galvanised after manufacture)
D (deep galvanised)
S (stainless steel)
E (powder coated)

All dimensions (mm) are nominal

Swifts® cable ladder ancillary items

tee brackets

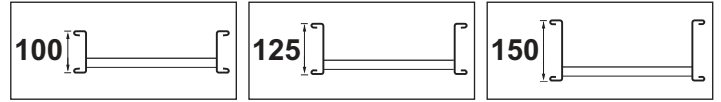

Tee brackets are a versatile means of carrying out the installation of a branch off a main cable ladder run. The branch can be installed at any position along the main run of ladder without cutting or drilling, making this approach particularly useful for installing a new branch onto an existing installation

The branch ladder may be the same type and width as the main run or it may be a lighter type and / or a narrower width

The branch ladder can be installed in either a horizontal or vertical position (as shown below). However, with the use of bendable or hinged connectors (shown on p. 41-42) any orientation of the ladder is possible

Supplied in pairs with fasteners

Installation (typical)

Horizontal connection

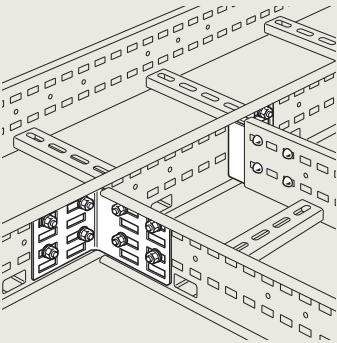

Vertical connection

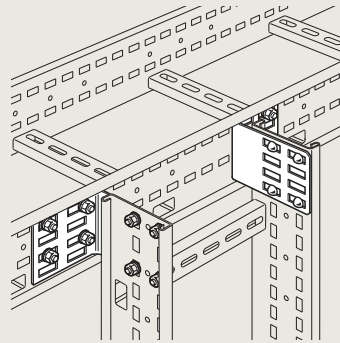

Main ladder run	Permitted ladder branch		
	Topaz	Sapphire	Emerald
Topaz	ZTB F	–	–
Sapphire	ZTB F	PTB F	–
Emerald	ZTB F	PTB F	ETB F

Tee brackets when used with bendable connectors or vertical hinged connectors are an economical and fast way of coping with unforeseen problems as they arise during installation

Tee brackets used with vertical hinged connectors

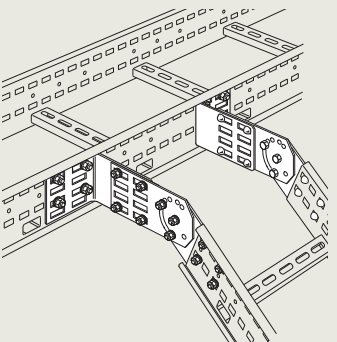

Tee brackets used with bendable connectors

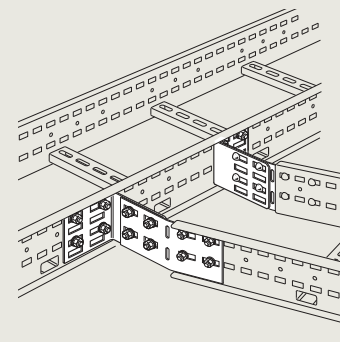

Note

Rigid support for the main ladder run should be provided immediately adjacent to the installed position of the branch. The cable loading on the branch should be treated as a point load applied unevenly to the main ladder run and the implications of this must be properly considered

Key : Replace the letter shown in red with your choice from the following options :

- F = Finish : G (hot dip galvanised after manufacture)
- D (deep galvanised)
- S (stainless steel)
- E (powder coated)

Assembly

Bracket to ladder fasteners (included)

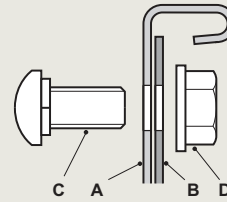

- A Side rail
- B Bracket
- C M10 x 20 coachbolt
- D M10 flange nut

	Topaz	Ladder range Sapphire	Emerald
Cat. Nos.	ZTB F	PTB F	ETB F
Quantity of fasteners per bracket	8 x M10	8 x M10	8 x M10

Recommended Torque Setting (M10): 40Nm

Fastener finishes

For ladders with G and D finishes, fasteners are galvanised or zinc plated. For ladders with S finish, fasteners are corrosion resistant stainless Grade A470

For ladders with E finish, the fasteners are Grade 8.8 hot dip galvanised

An alternative material for fasteners may be required depending on the installation environment - contact us on +44 (0) 845 605 4333

Dimensions and weights

Medium duty (Topaz) ZTB F

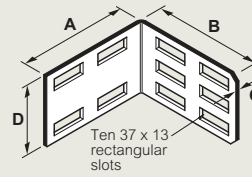

Heavy duty (Sapphire) PTB F and extra heavy duty (Emerald) ETB F

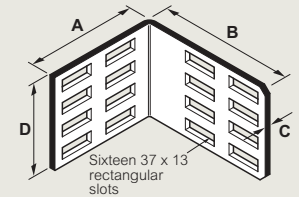

Cat. Nos.	A	B	C	D	Weight (kg)
ZTB F	125	125	2.0	78	0.5
PTB F	125	155	3.0	103	1.0
ETB F	125	155	3.0	103	1.0

Weights

All weights given are in kilograms (kg) and are for a pair of brackets in hot dip galvanised G finish

To obtain the appropriate component weight in other finishes, multiply the given weight by the following factors :

- Deep galvanised (D) x 1.07
- Stainless steel (S) x 0.94
- Powder coated (E) x 0.97

All dimensions (mm) are nominal

→ Bendable connectors : see p. 41

→ Vertical hinged connectors : see p. 42

Swifts® cable ladder ancillary items

short reducer brackets

Short reducer brackets can be used with all cable ladder ranges to provide a simple and economical way of forming a reducer on site. A single bracket can be used with a straight coupler to form either a left hand or right hand offset reducer, whereas two brackets are used to form a straight reducer. In the same way, short reducer brackets can be used to convert an equal tee into an unequal tee. Six sizes of bracket are available to fit each ladder range, providing a full range of reductions from 75 mm to 750 mm. Brackets can be fitted to the end of a full or cut ladder length without the need for drilling. When fitted to a cut length, the bracket provides a safe edge. Supplied singly with fasteners.

Installation (typical)

Offset reducer
(Use single bracket with straight coupler)

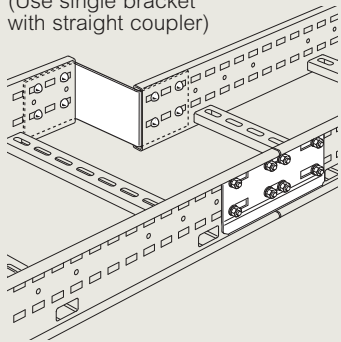

Straight reducer
(Use brackets in pairs)

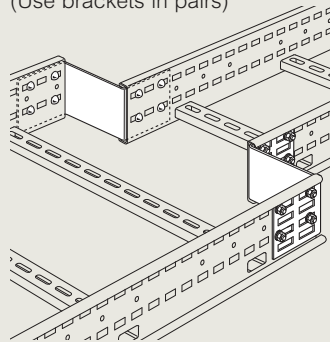

Ladder cut ends must have a minimum clear length of 150mm before the first rung when fitting short reducer brackets. Rigid support for the cable ladder should be provided on both sides adjacent to each joint.

Assembly

Fasteners (included)

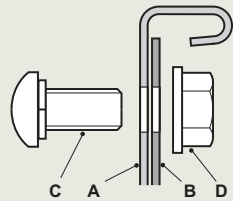

- A M10 x 20 coachbolt
- B Bracket
- C Side rail
- D M10 flange nut

Cat. Nos.	Ladder range		
	Topaz	Sapphire	Emerald
Quantity of fasteners per bracket	4	8	8

Recommended Torque Setting (M10): 40Nm

Fastener finishes

For ladders with G and D finishes, fasteners are galvanised or zinc plated. For ladders with S finish, fasteners are corrosion resistant stainless Grade A470.

For ladders with E finish, the fasteners are Grade 8.8 hot dip galvanised.

An alternative material for fasteners may be required depending on the installation environment - contact us on +44 (0) 845 605 4333.

Key : Replace the letter shown in red with your choice from the following options :

- Y = Ladder width reduction
- F = Finish : G (hot dip galvanised after manufacture)
D (deep galvanised)
S (stainless steel)
E (powder coated)

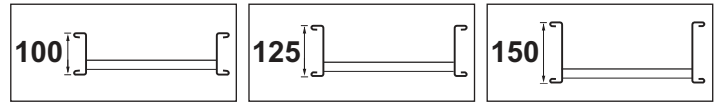

Ordering details

Supplied singly with fasteners
Use to form a reducer on site

Straight reducer
– use in pairs

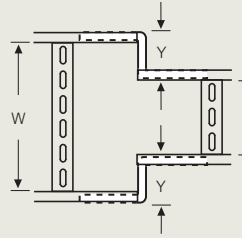

Offset reducer
– use singly with straight coupler

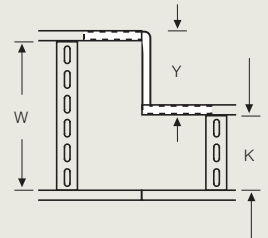

Use the following calculations to establish ladder width reduction. This measurement (Y), can then be inserted into relevant Cat. Nos. to show bracket size required (see p. 23).

Offset reducer $Y = W - K$ **Straight reducer** $Y = \frac{W - K}{2}$

W = main ladder mm
K = reduced ladder mm

Dimensions and weights

Medium duty
(Topaz) ZR^F

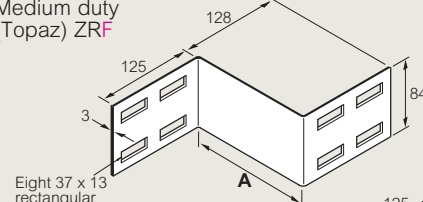

Heavy duty
(Sapphire) PR^F

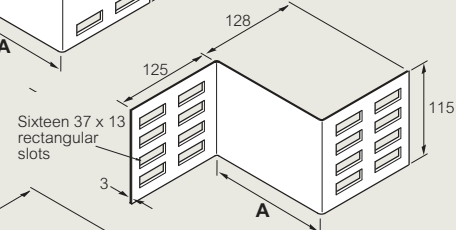

Extra heavy duty
(Emerald) ER^F

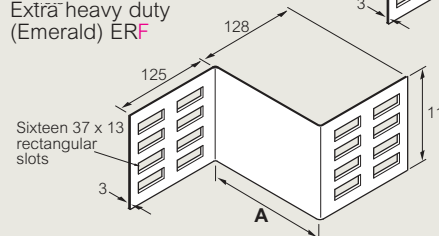

Ladder width difference	Weight (kg)			
	A	ZR	PR	ER
75	78	0.6	0.7	1.0
150	153	0.7	0.8	1.1
300	303	1.0	1.2	1.5
450	453	1.3	1.5	2.0
600	603	1.7	1.9	2.4
750	753	2.0	2.3	2.9

Weights

All weights given are in kilograms (kg) and are for hot dip galvanised G finish.

To obtain the appropriate component weight in other finishes, multiply the given weight by the following factors :

- Deep galvanised (D) x 1.07
- Stainless steel (S) x 0.94
- Powder coated (E) x 0.97

All dimensions (mm) are nominal

Swifts® cable ladder ancillary items

ancillary mounting brackets

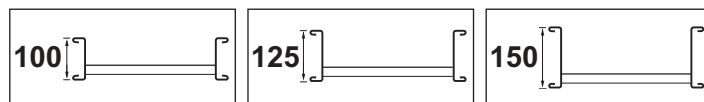

Ancillary mounting brackets are designed to enable ancillary equipment to be mounted to horizontal or vertical cable ladder runs and can be used singly to support small items, or any number can be used for larger or heavier items

Slots for M6 fasteners are provided for mounting ancillary items
Supplied singly with bracket to ladder fasteners

■ Installation (typical)

Cat. No. AMBWF

For services below

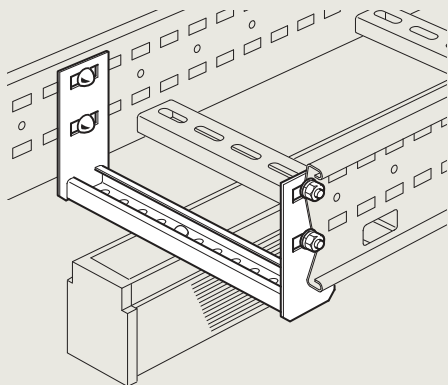

For services above

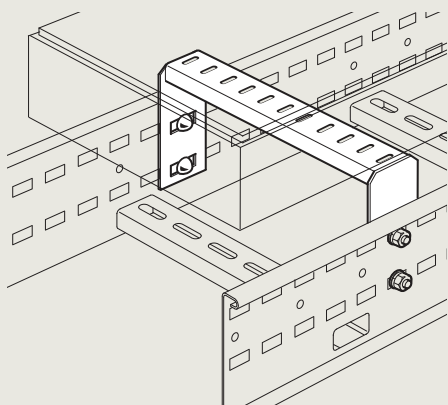

For services vertically

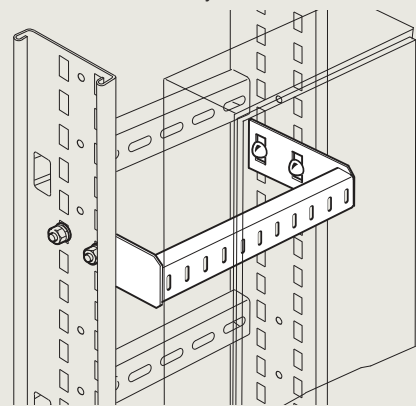

■ Assembly

Bracket to ladder fasteners (included)

Four fasteners per bracket

Recommended Torque Setting (M10): 40Nm

M10 x 20 coachbolt

M10 flange nut

Fastener finishes

For ladders with G and D finishes, fasteners are high tensile Grade 8.8

For ladders with S finish, fasteners are corrosion resistant stainless Grade A470

For ladders with E finish, the fasteners are Grade 8.8 hot dip galvanised

An alternative material for fasteners may be required depending on the installation environment - contact us on +44 (0) 845 605 4333

Bracket to ancillary fasteners (not included)

Slots are provided for attaching ancillary items

■ Dimensions and weights

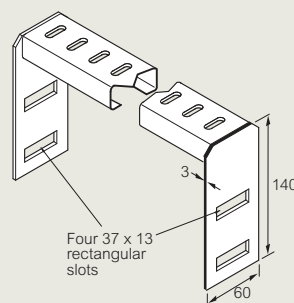

Ladder width (w)	Weight (kg)
150	0.6
300	0.7
450	0.8
600	1.0
750	1.4
900	1.6

Weights

All weights given are in kilograms (kg) and are for hot dip galvanised G finish

To obtain the appropriate component weight in other finishes, multiply the given weight by the following factors :

Deep galvanised (D) x 1.07

Stainless steel (S) x 0.94

Powder coated (E) x 0.97

Key : Replace the letter shown in red with your choice from the following options :

W = Width (mm) 150, 300, 450, 600, 750, 900

F = Finish : G (hot dip galvanised after manufacture)

D (deep galvanised)

S (stainless steel)

E (powder coated)

All dimensions (mm) are nominal

Swifts® cable ladder ancillary items

ancillary mounting plate

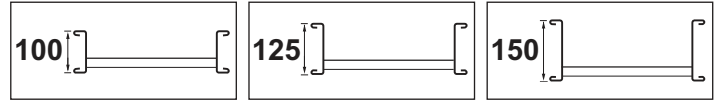

Ancillary mounting plates are used for mounting small and lightweight items of ancillary equipment to cable ladder runs and can be fitted to bridge adjacent rungs on all cable ladder ranges, or fixed perpendicularly to the inside of a side rail. Supplied singly with plate to ladder fasteners.

Installation (typical)

Cat. No. MP F

Rung mounting

Side rail mounting

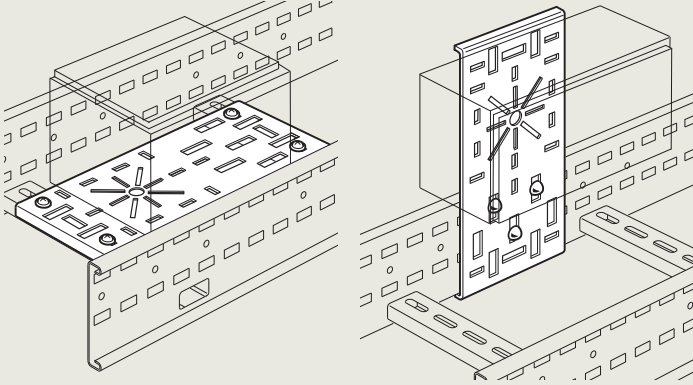

Assembly

Plate to ladder fasteners (included – see opposite for positioning)

Four fasteners per plate for fixing position A

Three fasteners per plate for fixing position C

Recommended Torque Setting (M10): 40Nm

A

M10 x 20 coachbolt

M10 flange nut

C

M10 x 20 coachbolt

M10 flange nut

Fastener finishes

For ladders with G and D finishes, fasteners are galvanised or zinc plated. For ladders with S finish, fasteners are corrosion resistant stainless Grade A470

For ladders with E finish, the fasteners are Grade 8.8 hot dip galvanised

An alternative material for fasteners may be required depending on the installation environment - contact us on +44 (0) 845 605 4333

Plate to ancillary fasteners (not included)

Slots are provided for attaching ancillary items

Assembly (continued)

Rung fixing position (A)

All ladder ranges

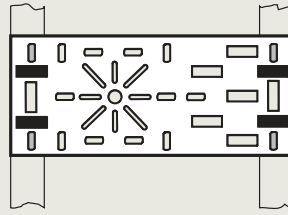

Side rail fixing positions (C)

Medium duty (Topaz)

Heavy duty (Sapphire) and extra heavy duty (Emerald)

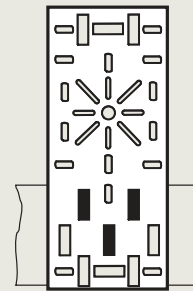
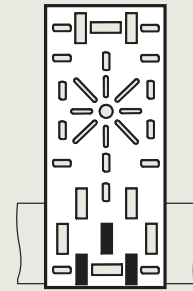

Dimensions and weights

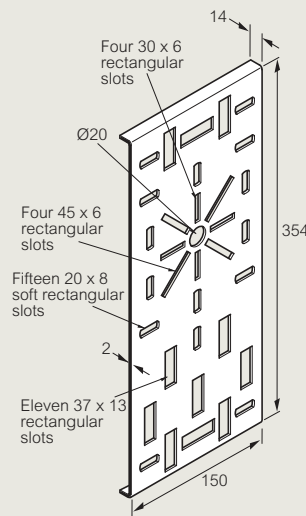

Weights

All weights given are in kilograms (kg) and are for hot dip galvanised G finish

To obtain the appropriate component weight in other finishes, multiply the given weight by the following factors :

Deep galvanised (D) x 1.07

Stainless steel (S) x 0.94

Powder coated (E) x 0.97

Key : Replace the letter shown in red with your choice from the following options :

F = Finish : G (hot dip galvanised after manufacture)
 D (deep galvanised)
 S (stainless steel)
 E (powder coated)

All dimensions (mm) are nominal

Swifts® cable ladder ancillary items

cable support bracket

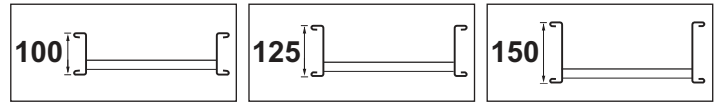

Cable support brackets are designed for use with all cable ladder ranges when the ladder is installed with the rungs vertical. Several brackets can be fitted to each rung at a minimum spacing of 100 mm. The maximum recommended cable loading is 30 kg per bracket.

Supplied singly with fasteners but without cable ties.

■ Installation (typical)

Cat. No. CSB F

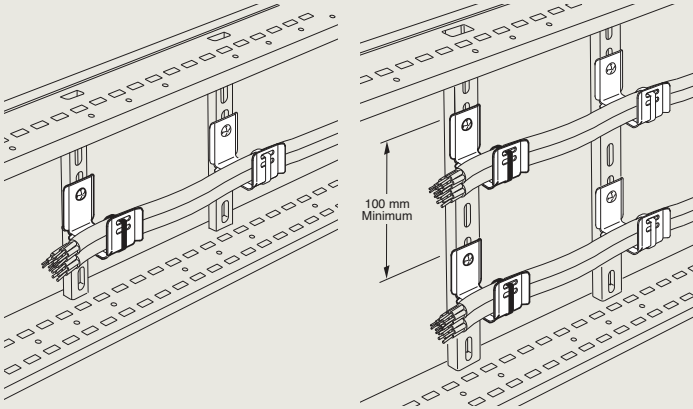

■ Assembly

Fasteners (included)

One fastener per bracket

G and D finishes

M6 x 12 roofing bolt
M6 roofing washers (2 off)
M6 nut

S finish

M6 x 12 pan head screw
M6 form A washer
M6 square washer
M6 nut

Fastener finishes

For ladders with G and D finishes, fasteners are galvanised or zinc plated. For ladders with S finish, fasteners are corrosion resistant stainless Grade A470.

For ladders with E finish, the fasteners are Grade 8.8 hot dip galvanised.

An alternative material for fasteners may be required depending on the installation environment - contact us on +44 (0) 845 605 4333.

■ Dimensions and weights

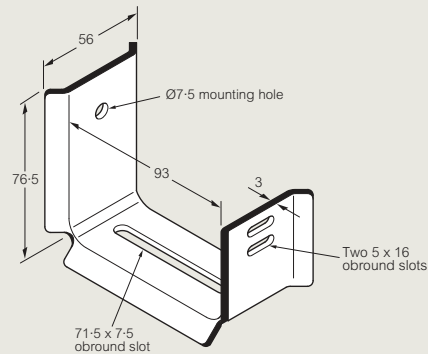

Weights

All weights given are in kilograms (kg) and are for hot dip galvanised G finish.

To obtain the appropriate component weight in other finishes, multiply the given weight by the following factors:

Deep galvanised	(D) x 1.07
Stainless steel	(S) x 0.94
Powder coated	(E) x 0.97

Key : Replace the letter shown in red with your choice from the following options :

F = Finish : **G** (hot dip galvanised after manufacture)
D (deep galvanised)
S (stainless steel)
E (powder coated)

All dimensions (mm) are nominal

Swifts® cable ladder ancillary items

stop ends

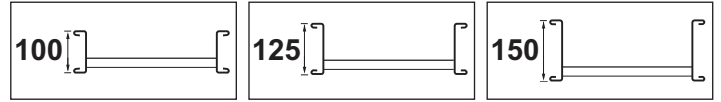

Stop ends provide both a neat method of terminating a cable ladder run and also an alternative to the use of 90° connectors for fixing the end of a cable ladder run to a vertical surface (steel, concrete or masonry)

Supplied singly with stop end to ladder fasteners

Installation (typical)

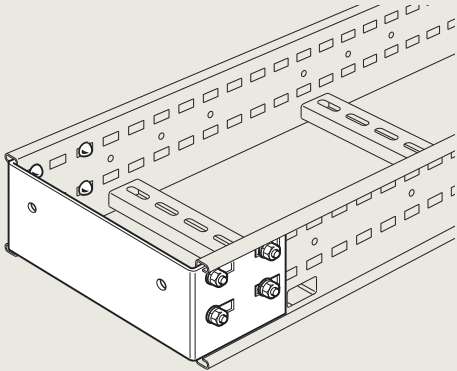

Cat. Nos.	Ladder range		
	Topaz	Sapphire	Emerald
	ZSWF	PSWF	ESWF
Quantity of fasteners per bracket	8	8	8

Assembly

Stop end to ladder fasteners (included)

Recommended torque setting (M10) : 40Nm

M10 x 20 coachbolt

M10 flange nut

Fastener finishes

For ladders with G and D finishes, fasteners are galvanised or zinc plated. For ladders with S finish, fasteners are corrosion resistant stainless Grade A470

For ladders with E finish, the fasteners are Grade 8.8 hot dip galvanised

An alternative material for fasteners may be required depending on the installation environment - contact us on +44 (0) 845 605 4333

Stop end to support fasteners (not included)

Holes are provided for M10 setscrews – length and finish to suit application

Dimensions and weights

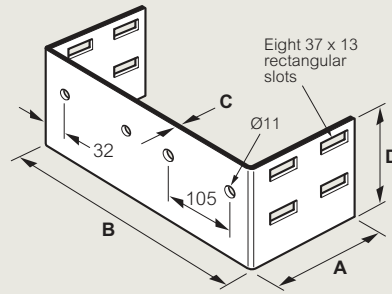

Additional holes for ladder widths 600 and over

Cat. Nos.	Topaz (ZS)					Sapphire (PS)					Emerald (ES)				
	Ladder width (W)	A	B	C	D	Wt (kg)	A	B	C	D	Wt (kg)	A	B	C	D
150	127	154	2-0	84	0-4	127	154	2-0	115	0-6	127	154	2-0	140	0-6
300	127	304	2-0	84	0-6	127	304	2-0	115	0-9	127	304	2-0	140	1-0
450	127	454	2-0	84	0-7	127	454	2-0	115	1-2	127	454	2-0	140	1-9
600	127	604	2-0	84	0-9	127	604	2-0	115	1-4	127	604	2-0	140	1-7
750	127	754	2-0	84	1-0	127	754	2-0	115	1-7	127	754	2-0	140	2-0
900	127	904	2-0	84	1-2	127	904	2-0	115	2-0	127	904	2-0	140	2-4

Weights

All weights given are in kilograms (kg) and are for hot dip galvanised G finish

To obtain the appropriate component weight in other finishes, multiply the given weight by the following factors :

Deep galvanised (D) x 1.07

Stainless steel (S) x 0.94

Powder coated (E) x 0.97

Key : Replace the letter shown in red with your choice from the following options :

W = Width (mm) 150, 300, 450, 600, 750, 900

F = Finish : G (hot dip galvanised after manufacture)

D (deep galvanised)

S (stainless steel)

E (powder coated)

All dimensions (mm) are nominal

Swifts® cable ladder ancillary items

covers for straight lengths

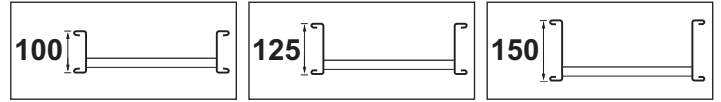

Medium duty (Topaz), heavy duty (Sapphire) and extra heavy duty (Emerald) use the same covers and closed / ventilated clips
 Covers can be installed either by resting directly on the ladder side rails (closed covers) or raised above the side rails providing a gap for air to circulate (ventilated covers)
 Covers up to 450 mm wide have a flat top surface and are simply butt-jointed together. Covers 600 mm wide and above are overlapped and bolted together to increase their rigidity. Covers 750 and 900 mm wide have a stiffener fitted along the joint for added rigidity
 All covers are 3 m in length and supplied with six cover clips and associated fasteners

For ordering information, see p. 23

Installation (typical)

Closed cover installations

Up to 450 wide

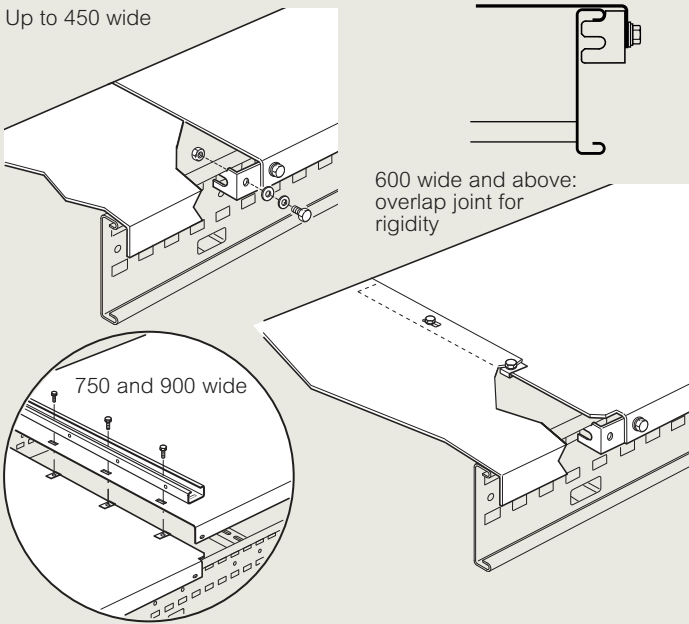

600 wide and above:
overlap joint for rigidity

Ventilated cover installations

Up to 450 wide

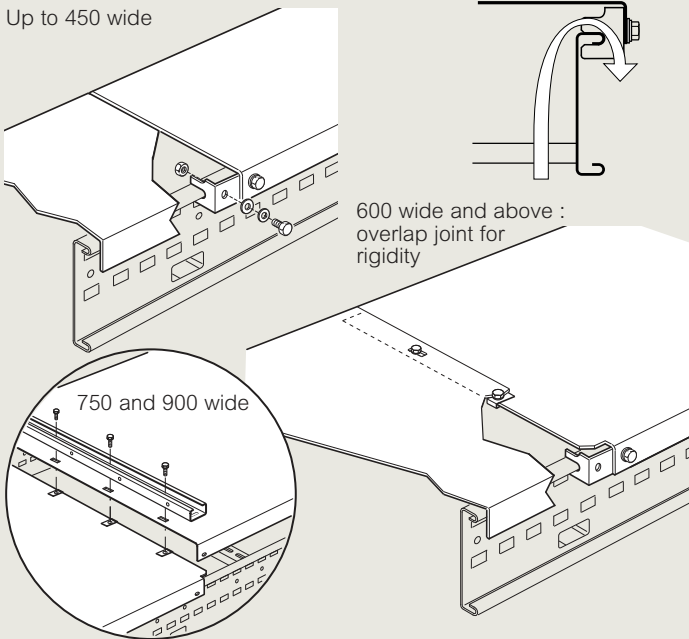

600 wide and above :
overlap joint for rigidity

Installation (typical) (continued)

Lid in run-off position

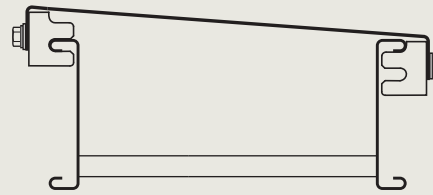

Assembly

Cover clip positions

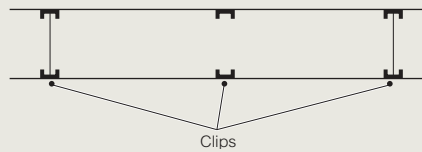

Clips are fitted to the inside of both cover side flanges as shown; the end clips provide anchorage for the joined ends of adjacent covers

Note

Covers can not be used when hanger rod brackets are fitted to ladder

Fasteners (included)

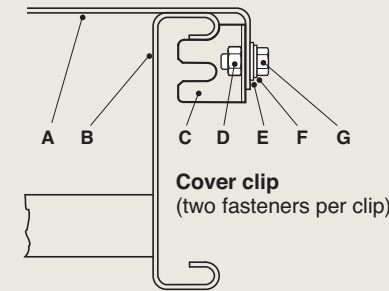

- A Cover
- B Side rail
- C Cover clip
- D M8 nut
- E M8 form A washer
- F Spring washer
- G M8 x 16 setscrew
- H Cover
- J 'U'-shape retaining nut
- K M6 x 16 setscrew
- L M6 form A washer
- M Spring washer
- N Stiffener

Overlap joint on 600 wide (two fasteners per joint)

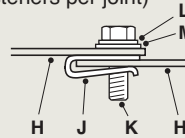

Overlap joint on 750 and 900 wide (four fasteners per joint)

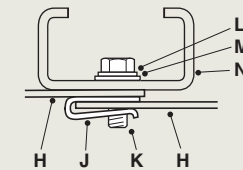

Fastener finishes

For ladders with G and D finishes, fasteners are galvanised or zinc plated. For ladders with S finish, fasteners are corrosion resistant stainless Grade A470

For ladders with E finish, the fasteners are Grade 8.8 hot dip galvanised

An alternative material for fasteners may be required depending on the installation environment, for details contact us on +44 (0) 845 605 4333

Key : Replace the letter shown in red with your choice from the following options :

W = Width (mm) 150, 300, 450, 600, 750, 900

F = Finish : G (hot dip galvanised after manufacture)

D (deep galvanised)

S (stainless steel)

E (powder coated)

All dimensions (mm) are nominal

Swifts® cable ladder ancillary items

covers for straight lengths (continued)

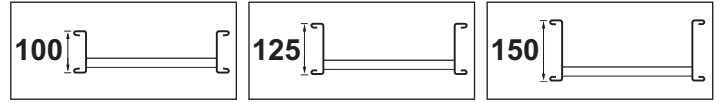

■ Assembly (continued)

Covers

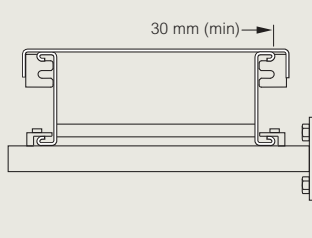

General

Before fitting the covers ensure a minimum clearance of 30 mm between the ladder and the vertical support face. For access to fit cover clips a larger clearance is required when the vertical support is a solid face

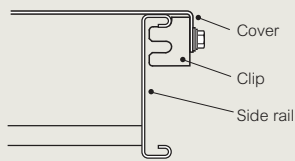

Closed covers

Place each cover over the ladder side rails and push the clip under the side rail return flanges before fitting and tightening the fasteners

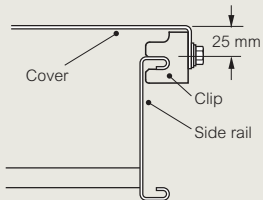

Ventilated covers

Slide the clips over the top return flange of the ladder side rails and place the cover over the clips. Fit and tighten the fasteners

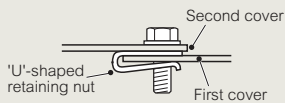

Wide covers – 600 mm and above

For wider covers with overlapped joints, fit the first cover as above. Push the 'U' shaped retaining nuts over the holes in the overlap tongue. Fit the second cover with its straight end overlapping the tongue on the first cover. Insert fasteners and secure

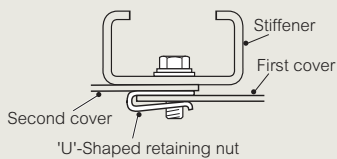

700 and 900mm wide covers

For covers fitted with a stiffener, assemble the covers as described above and place the stiffener on to the top cover along the joint. Insert fasteners and secure

■ Dimensions and weights – covers

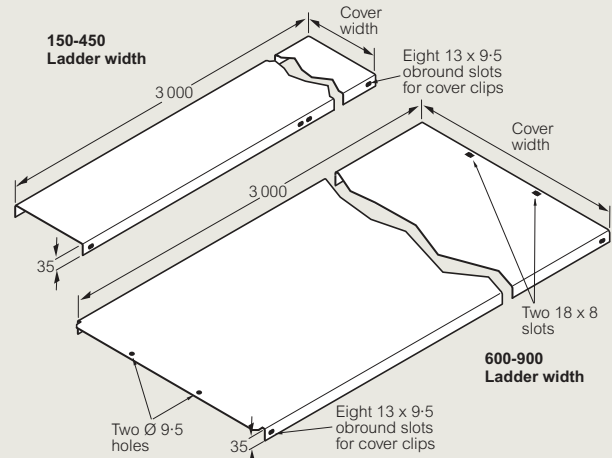

Widths 750 and 900 have two additional 18 x 8 slots and Ø 9.5 holes to accept stiffener for added rigidity

Ladder width (w)	Cover width	Weight (kg)
150	232	11.0
300	382	16.6
450	532	22.2
600	682	28.0
750	832	33.6
900	982	39.3

■ Dimensions and weights – clips

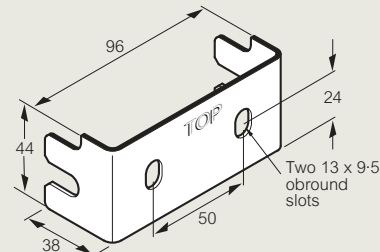

Weight: 0.5 kg per 4 clips

Weights

All weights given are in kilograms (kg) and are for hot dip galvanised G finish

To obtain the appropriate component weight in other finishes, multiply the given weight by the following factors :

Deep galvanised	(D) x 1.07
Stainless steel	(S) x 0.94
Powder coated	(E) x 0.97

Key : Replace the letter shown in red with your choice from the following options :

W = Width (mm) 150, 300, 450, 600, 750, 900

F = Finish : G (hot dip galvanised after manufacture)

D (deep galvanised)

S (stainless steel)

E (powder coated)

All dimensions (mm) are nominal

Swifts® cable ladder ancillary items

covers for fittings

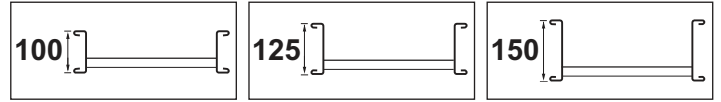

Covers are supplied to fit all fittings in the medium duty (Topaz), heavy duty (Sapphire) and extra heavy duty (Emerald) cable ladder ranges. Covers can be installed either by resting directly on the fitting side rails (closed covers) or raised above the side rails providing a gap for air to circulate (ventilated covers).

Covers for fittings up to 450 mm wide are simply butt-jointed together. Covers 600 mm wide and above are overlapped and bolted together to increase their rigidity. Covers 750 and 900 mm wide have a stiffener fitted along the joint for added rigidity.

All covers are supplied with the appropriate number of fasteners.

Installation (typical)

Closed cover installation

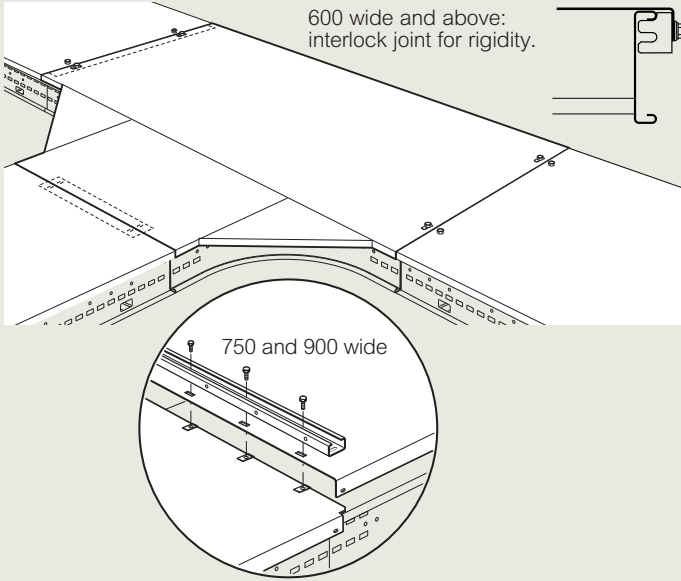

Ventilated cover installation

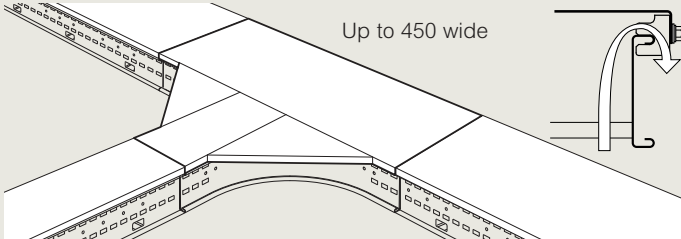

To order a cover for a fitting, (except risers) remove first letter of fitting product code (Z, P or E) and add CV before your chosen dimensions. Example: Product code = PFB 300 90 600 G

Cover code = FB CV 300 90 600 G

Riser covers are specific for Z, P or E

For risers :

Ladder range		Topaz	Sapphire	Emerald
Inside risers	Closed covers	ZIRC	PIRC	EIRC
Cat. Nos.	Ventilated covers	ZIRV	PIRV	EIRV
Outside risers	Closed covers	ZORC	PORC	EORC
Cat. Nos.	Closed covers	ZORC	PORC	EORC

Key : selecting for ancillary items and covers. Replace the letters shown in red with your choice from the following options :

W = Widths : 150, 300, 450, 600, 750, 900

Y = Ladder width reduction A = Angle (°) : 90 or 45

F = Finish : G (hot dip galvanised after manufacture), D (deep galvanised) S (stainless steel), E (powder coated)

r = Radius (mm) : 300, 600

Assembly

Cover clip positions

Clips are fitted to the inside of cover side flanges as shown ; the end clips provide anchorage for the joined ends of adjacent covers

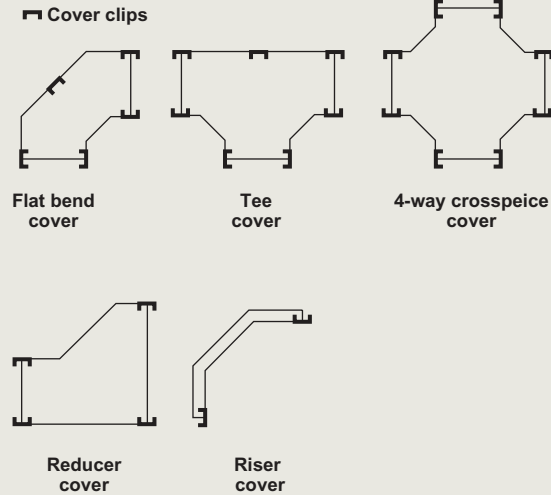

Note

Covers can not be used when hanger rod brackets are fitted to ladder

Fasteners (included)

Cover clip

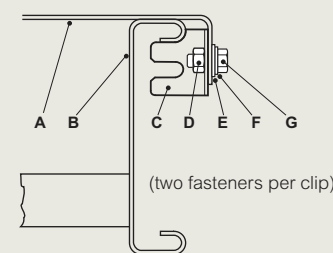

- A Cover
- B Side rail
- C Cover clip
- D M8 nut
- E M8 form A washer
- F Spring washer
- G M8 x 16 setscrew
- H Cover
- J 'U'-shape retaining nut
- K M6 x 16 setscrew
- L M6 form A washer
- M Spring washer
- N Stiffener

Overlap joint on 600 wide

(two fasteners per joint)

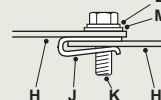

Overlap joint on 750 and 900 wide

(two fasteners per joint)

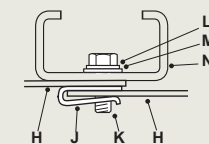

Fastener finishes

For ladders with G and D finishes, fasteners are galvanised or zinc plated. For ladders with S finish, fasteners are corrosion resistant stainless Grade A470

For ladders with E finish, the fasteners are Grade 8.8 hot dip galvanised

An alternative material for fasteners may be required depending on the installation environment - contact us on +44 (0) 845 605 4333

All dimensions (mm) are nominal

Swifts® cable ladder ancillary items

covers for fittings (continued)

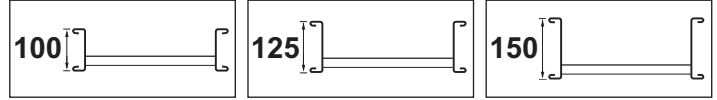

■ Assembly

Closed covers

To fit covers as closed, fit the cover over the fitting side rails and place the cover clips in position under the side rail return flanges. Fit and tighten the fasteners

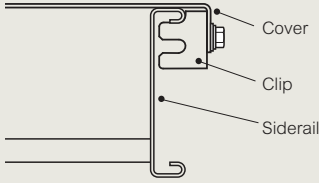

Ventilated covers

To fit the covers as ventilated, slide the clips over the top return flanges of the side rails and place the cover over the clips. Fit and tighten the fasteners.

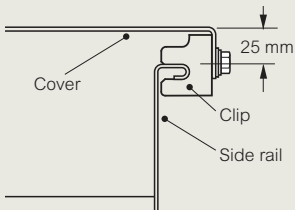

Joining covers

When wide (600 mm or over) covers are fitted, the fitting cover may join to either end of a straight length cover

If the straight cover has an overlap tongue, push 'U'-shaped retaining nuts over the holes in the tongue. Fit the fitting cover in position overlapping the tongue. Insert fasteners through both covers and the retaining nuts and tighten the fasteners

For 750 and 900 mm wide covers place the stiffener on to the top cover along the joint before inserting the fasteners

If the straight cover has not got an overlap tongue, fit four 'U'-shaped retaining nuts over the holes in a joint strip and position the strip under the butt-joint between covers. Insert fasteners through each cover and the two aligning holes in the joint strip and tighten the fasteners

For fitting a stiffener (covers 750 and 900 mm wide) refer to paragraph above

Note

It may be necessary to drill holes in the straight cover if it has been cut to length

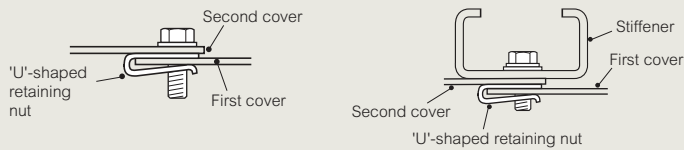

■ Dimensions and weights – covers

For information on dimensions and weights for specific fitting covers, contact us on +44 (0) 845 605 4333

Refer to p. 96 for cover clip dimensions and weights

Key : selecting for ancillary items and covers. Replace the letters shown in red with your choice from the following options :

W = Widths : 150, 300, 450, 600, 750, 900

Y = Ladder width reduction A = Angle (°) : 90 or 45

F = Finish : G (hot dip galvanised after manufacture),
D (deep galvanised) S (stainless steel), E (powder coated)

r = Radius (mm) : 300, 600

All dimensions (mm) are nominal

Swiftrack® channel lengths

single channels – plain and slotted

■ Single channels – plain

Single channels are available in standard and light gauge options in 3 and 6 m lengths, supplied singly
 Standard channels are cold rolled to BS 6946 from 2.5 mm pre-galvanised mild steel to BS EN 10346 : 2009 Grade S250GD + Z275
 Light gauge channels are cold rolled from 1.5 mm pre-galvanised mild steel to BS EN 10346 : 2009 Grade S250GD + Z275
 All single channels are designed to accept channel nuts, see p. 101

Standard

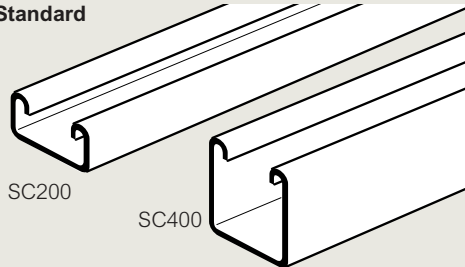

Light gauge

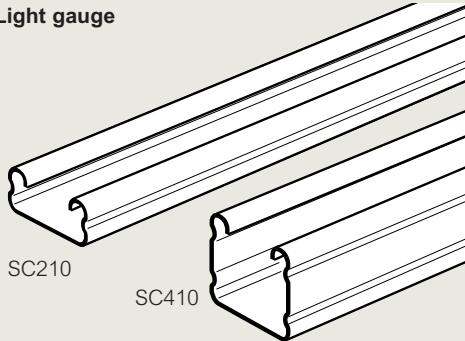

■ Dimensions and weights

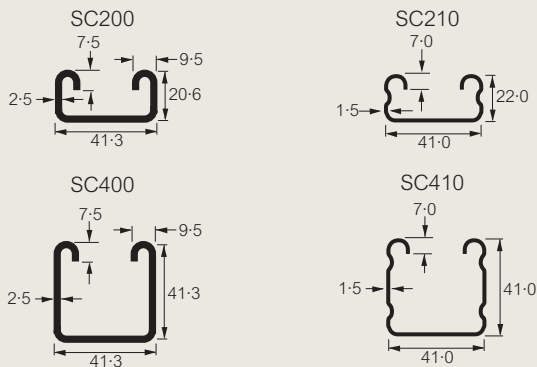

	Cat. Nos.		Weight (kg) per m
	3 m long	6 m long	
Standard Channel	SC200 3M	SC200 6M	1.8
	SC400 3M	SC400 6M	2.6
Light gauge Channel	SC210 3M	SC210 6M	1.2
	SC410 3M	SC410 6M	1.7

Cat. Nos. given are for standard finish single channel
 For alternative finishes, see opposite

■ Single channels – slotted

Slotted channels are available in standard and light gauge options in 3 and 6 m lengths, supplied singly
 Swiftrack channels conform to BS 6946

Standard

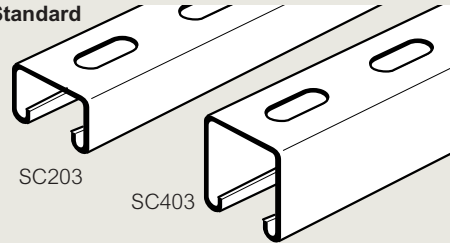

Light gauge

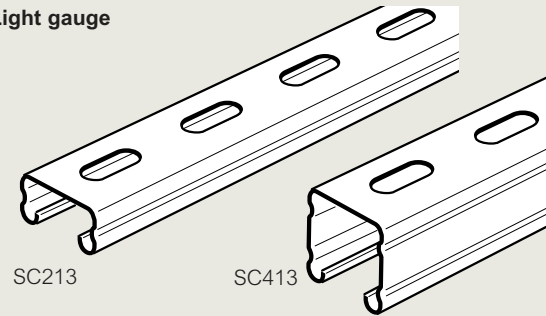

■ Dimensions and weights

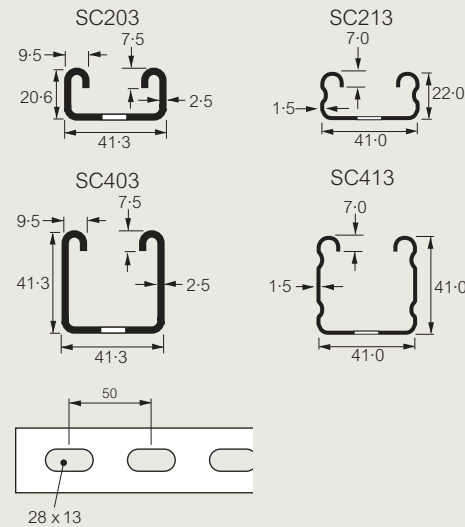

Slot pattern may differ on stainless steel channels

	Cat. Nos.		Weight (kg) per m
	3 m long	6 m long	
Standard Channel	SC203 3M	SC203 6M	1.8
	SC403 3M	SC403 6M	2.6
Light gauge Channel	SC213 3M	SC213 6M	1.2
	SC413 3M	SC413 6M	1.7

Cat. Nos. given are for standard finish single channel
 For alternative finishes see below

Weights

All weights given are in kilograms (kg) based on nominal thickness and are for pre-galvanised finish
 For weights in alternative finishes contact us on +44 (0) 845 605 4333

■ Finishes and standards

Standard finish :

Pre-galvanised mild steel to BS EN 10346 : 2009 Grade S250GD + Z275 finish (structural grade)

Alternative finishes :

G Hot dip galvanised after manufacture to BS EN ISO 1461
 S Stainless steel to BS EN 10088 : 2005 Grade 1.4404 (equivalent to S316L31)

All dimensions (mm) are nominal

Swiftrack® channel lengths

back-to-back channels and section properties

■ Back-to-back channels

Back to back channels are available in 3 and 6 m lengths, supplied singly

Back-to-back channels are formed by spot welding together two finished single channels at 150 mm centres under controlled conditions to BS EN 1993-1-3 : 2006. All welds and spot welds are suitably protected

■ Dimensions and weights

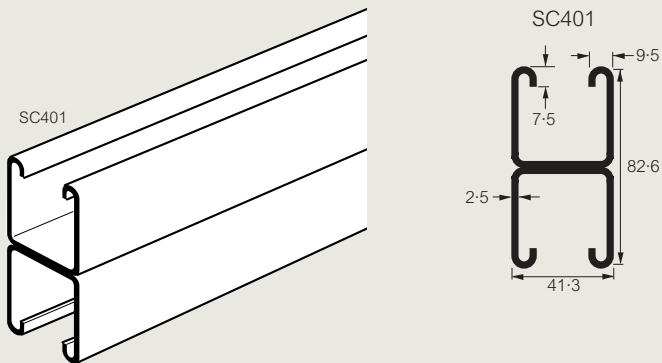

	Cat. Nos.		Weight (kg) per m
	3 m long	6 m long	
Back-to-back channel	SC401 3M	SC401 6M	5.3

Cat. Nos. given are for standard finish back-to-back channel
For alternative finishes see below

Weights

All weights given are in kilograms (kg) based on nominal thickness and are for pre-galvanised finish

For weights in alternative finishes contact us on +44 (0) 845 605 4333

■ Finishes and standards

Standard finish :

Pre-galvanised mild steel to BS EN 10346 : 2009 Grade S250GD + Z275 finish (structural grade)

Alternative finishes :

G Hot dip galvanised after manufacture to BS EN ISO 1461

S Stainless steel to BS EN 10088 : Grade 1.4404 (equivalent to S316L31)

■ Section properties

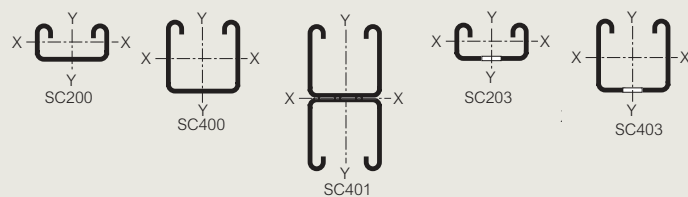

Cat. Nos.	Wt (kg/m)	A (mm ²)	I_{xx} (mm ⁴)	Z_{top} (min) (mm ³)	Z_{bottom} (max) (mm ³)	r_{xx} (mm)	I_{yy} (mm ⁴)	r_{yy} (mm)
SC200	1.8	219	10 779	862	1 330	7.1	49 776	15.1
SC203	1.6	219	8 960	794	961	6.4	49 318	15.0
SC400	2.6	322	67 157	2 857	3 772	14.5	88 783	16.6
SC401	5.3	645	339 300	8 215	8 215	23.0	177 566	16.6
SC403	2.4	322	57 221	2 645	2 909	13.3	88 325	16.5

Wt = weight of section (kg/m)

A = cross-sectional area (mm²)

I_{xx} = moment of inertia = second moment of area (mm⁴)

Z_{top} = section modulus about xx axis (mm³)

Z_{bottom} = section modulus about xx axis (mm³)

r_{xx} = radius of gyration (mm)

I_{yy} = moment of inertia = second moment of area (mm⁴)

r_{yy} = radius of gyration (mm)

xx = about xx axis

yy = about yy axis

All dimensions (mm) are nominal

→ Swiftrack brackets : see p. 104-107

Swiftrack® channel support system assembly

■ Assembly

Fasteners for single (plain and slotted) and back-to-back channel supplied separately

Fixing brackets to Swiftrack channel

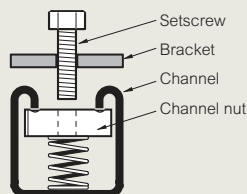

Standard fasteners for Swiftrack are high tensile hexagon head setscrews to BS 3692-8.8, these being zinc plated to BS 3382 : Part 2. Most standard Swiftrack brackets are made from 5 or 6 mm gauge steel. The use of too long a fastener will prevent proper tightening because the bolt end will foul the bottom of the channel before the head tightens down on the fitting.

When fastening brackets other than Swiftrack, longer bolts may be required if the bracket thickness is greater than 8 mm.

Fixing ladder to Swiftrack channel

Use M10 x 16 mm high tensile hexagon head setscrews

■ Channel nuts

Channel nuts are for use with all channels and are supplied in packs of 100. For maximum load capacity M12 channel nuts should always be used.

Channel nuts conform to BS 6946

Long spring

Short spring

No spring

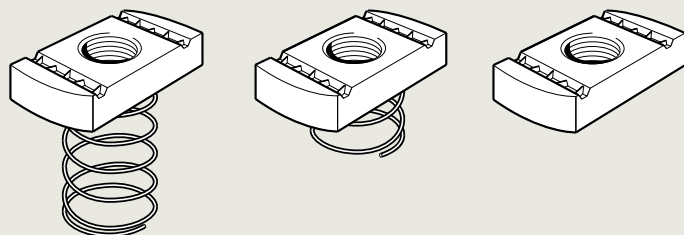

■ Dimensions and weights

Long spring

Short spring

No spring

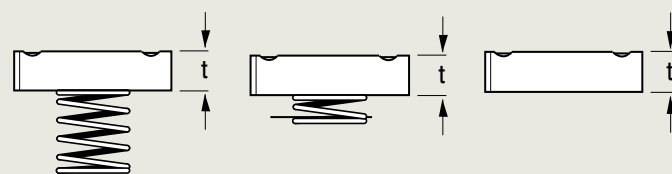

The safe working loads for zinc plated channel nuts only

Slip M10 : 3.0kN

M12 : 3.5kN

Pullout M10 : 6.0kN

M12 : 8.0kN

Safety Factor 3 when tested to BS 6946

Torque Tightened to M10 : 5.5 kgf.m (40ftlb)

M12 : 7.0 kgf.m (50ftlb)

	Cat. Nos.	Thread size	Depth of channel	t	Weight (kg) per 100
Long spring	PN061	M6	41	6.0	3.0
	PN081	M8	41	6.0	3.0
	PN101	M10	41	8.0	3.7
	PN121	M12	41	10.0	4.5
Short spring	PN062	M6	21	6.0	2.9
	PN082	M8	21	6.0	2.9
	PN102	M10	21	8.0	3.6
	PN122	M12	21	8.0	4.4
No spring	PN060	M6	ALL	6.0	2.8
	PN080	M8	ALL	6.0	2.8
	PN100	M10	ALL	8.0	3.5
	PN120	M12	ALL	10.0	4.3

Weights

All weights given are in kilograms (kg) based on nominal thickness, and are for zinc plated finish. For weights in stainless steel finish contact us on +44 (0) 845 605 4333

Note

Cat. Nos. given are for standard finish channel nuts, for alternative finish, see below

■ Finishes and standards

Standard finish

Zinc plated to BS 3382

G Hot dip galvanised after manufacture to BS EN ISO 1461

Alternative finish

S Stainless steel to BS EN 10088 : Grade 1.4404 (equivalent to S316L31)

All dimensions (mm) are nominal

Swiftrack® channel support system

cantilever arms

Cantilever arms are supplied singly without fasteners
 Cantilever arms conform to BS 6946

■ Dimensions and weights

Cantilever arms

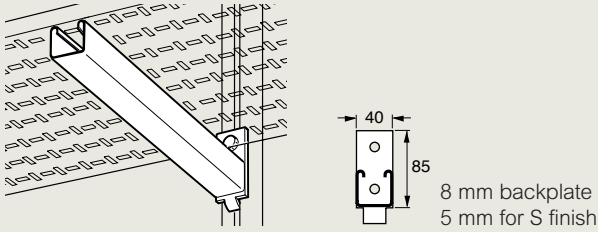

Cat. Nos.	Unit weight (kg)	Arm length (mm)	Maximum uniformly distributed load (kgf) ⁽¹⁾	Max. point load at outer end (kgf) ⁽¹⁾
SA750	0.64	150	350 ^{(2) (3)}	303
SA751	0.85	225	350 ⁽³⁾	198
SA752	1.03	300	304	152
SA753	1.42	450	202	101
SA754	1.81	600	150	75
SA755	2.20	750	110	55
SA757	2.60	900	90	45

Values assume the ladder or other loading medium is rigidly fixed to cantilever arm

(1) Based upon a load factor of 1.6 for hot dipped galvanised unrestrained condition as specified in BS EN 1993-1-3 : 2006

(2) Slip limits loading capacity

(3) Load limit is 50%

Cantilever arms, universal

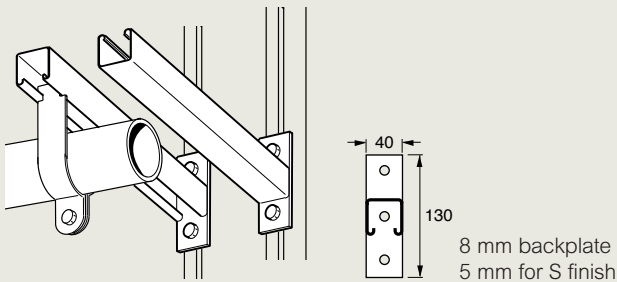

Cat. Nos.	Unit weight (kg)	Arm length (mm)	Maximum uniformly distributed load (kgf) ⁽¹⁾	Point load at outer end (kgf) ⁽¹⁾
SA760	0.64	150	700 ⁽²⁾	350
SA761	0.85	225	456	228
SA762	1.03	300	350	175
SA763	1.42	450	230	115
SA764	1.81	600	170	85
SA765	2.20	750	136	68
SA766	2.60	900	110	55

Values assume the ladder or other loading medium is rigidly fixed to cantilever arm

(1) Based upon a load factor of 1.6 for hot dipped galvanised unrestrained condition as specified in BS EN 1993-1-3 : 2006

(2) Load limit is 50%

■ Dimensions and weights (continued)

Cantilever arms, side

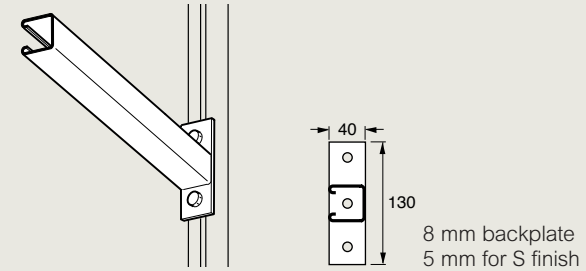

Cat. Nos.	Unit weight (kg)	Arm length (mm)
SA790	0.64	150
SA791	0.85	225
SA792	1.03	300
SA793	1.42	450
SA794	1.81	600
SA795	2.20	750
SA796	2.60	900

Cantilever arms, double channel

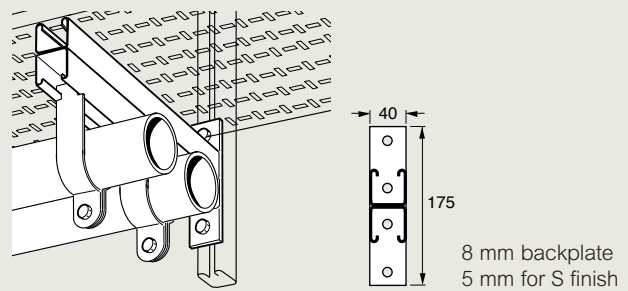

Cat. Nos.	Unit weight (kg)	Arm length (mm)	Maximum uniformly distributed load (kgf) ⁽¹⁾	Point load at outer end (kgf) ⁽¹⁾
SA770	1.14	150	700 ⁽²⁾⁽³⁾	648
SA771	1.68	225	700 ⁽²⁾⁽³⁾	420
SA772	2.02	300	650	325
SA773	2.90	450	430	215
SA774	3.78	600	320	160
SA775	4.66	750	250	125
SA776	5.60	900	200	100

Values assume the ladder or other loading medium is rigidly fixed to cantilever arm

(1) Based upon a load factor of 1.6 for hot dipped galvanised unrestrained condition as specified in BS EN 1993-1-3 : 2006

(2) Slip limits loading capacity

(3) Load limit is 50%

All dimensions (mm) are nominal

Swiftrack® channel support system

cantilever arms (continued)

■ Dimensions and weights (continued)

Cantilever arm bracket SA 756

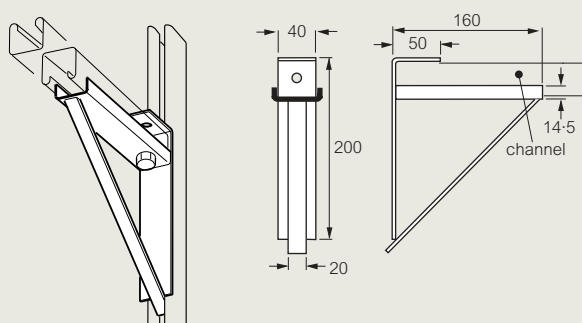

Horizontal arm section from 3 mm steel only
Weight each (kg) : 1.13

Weights

All weights given are in kilograms (kg) based on nominal thickness and standard finish

Loads

Maximum uniformly distributed loads for individual cantilever arms are given with the illustrations in this catalogue. However, should the loading not be uniform then the safe limit can be obtained by calculating the bending moment produced by the intended loads and comparing this with the maximum permissible bending moment for the relevant arm

45 kgf.m for SA750 – SA755 and SA757

52 kgf.m for SA760 – SA766

95 kgf.m for SA770 – SA776

To obtain the bending moment resulting from any point load, multiply the size of the load by its distance from the inner end of the arm (see illustration A)

If several point loads exist then the total bending moment will be the sum of the individual bending moment produced by each point load (see illustration B)

If some part of the total load applied to an arm is uniformly distributed along a section of the arm only, then this part load can be treated as a point load acting at the mid-point of that section of arm to which it is applied (see illustration C)

Illustration A

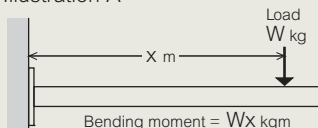

Illustration B

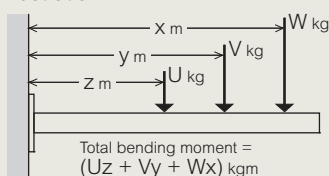
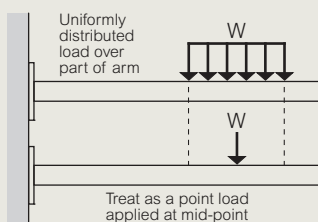

Illustration C



Values assume the ladder or other loading medium is rigidly fixed to cantilever arm

Stainless steel cantilever arms

Loads are 60% of those given in the tables, except for those marked (3), in the tables opposite, where the limit is 50%

■ Finishes and standards

The standard finish for all cantilever arms is hot dip galvanised steel to BS EN ISO 1461

Stainless steel to BS EN 10088 : Grade 1.4404 (equivalent to S316L31) is also available as an alternative where applicable

■ Assembly

Fasteners (not included)

Cantilever arms to Swiftrack channel

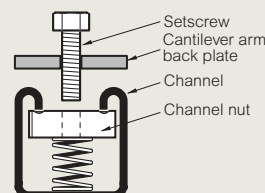

Standard fasteners for Swiftrack are high tensile hexagon head setscrews to BS 3692-8.8, these being zinc plated to BS 3382: Part 2. Most standard Swiftrack brackets are made from 5 or 6 mm gauge steel. Standard cantilever arm backplates are made from 8 mm gauge steel. The use of too long a fastener will prevent proper tightening because the bolt end will foul the bottom of the channel before the head tightens down on the fitting.

When fastening brackets other than Swiftrack, longer bolts may be required if the bracket thickness is greater than 8 mm

Channel type	Backplate thickness	Recommended fasteners
Deep channel SC400 series	6-8 mm 5-6 mm	M10 or M12 x 35 M10 or M12 x 25
Shallow channel SC200 series	7-8 mm 5-6 mm	M10 or M12 x 25 M10 or M12 x 20

Swiftrack® channel support system

framework brackets

All framework brackets are manufactured to BS 6946 from steel which complies with BS EN 10025 Grade S275JRC and are supplied singly. Channel nuts and setscrews are not supplied with brackets, therefore must be ordered separately

■ Dimensions and weights

Made from 5 or 6 mm thick steel unless otherwise stated
 Brackets are 40 mm wide and have 14 mm diameter holes to accept M12 (or smaller) setscrews
 All bend radii are 5 mm unless otherwise stated

Weights

All weights given are in kilograms (kg) based on nominal thickness and are for hot dip galvanised finish. For weights in stainless steel finish contact us on +44 (0) 845 605 4333

Loads

All loads are for hot dip galvanised brackets fixed with M12 setscrews and M12 zinc plated channel nuts. Loads for stainless steel brackets are available on request - contact us on +44 (0) 845 605 4333
 Minimum Yield Stress of material is 275 N/mm²

Only M10 or M12 channel nuts and bolts should be used for the attachment of load-bearing brackets

In most cases the mode of failure will be slippage of the bracket along the channel. However there are few channel/bracket combinations where the maximum load is dependant upon the strength of the bracket itself

■ Finishes and standards

The standard finish for all framework brackets and beam clamps is hot dip galvanised steel to BS EN ISO 1461

Stainless steel to BS EN 10088 : Grade 1.4404 (equivalent to S316L31) is also available as an alternative where applicable. To order stainless steel finish add **S** to the end of the standard catalogue number
 For example : SB500**S**

■ Assembly

Fasteners (not included)

Fixing brackets to Swiftrack channel

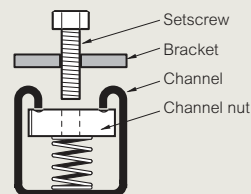

Standard fasteners for Swiftrack are high tensile hexagon head setscrews to BS 3692-8.8, these being zinc plated to BS 3382 : Part 2
 The use of too long a fastener will prevent proper tightening because the bolt end will foul the bottom of the channel before the head tightens down on the fitting

When fastening brackets other than Swiftrack, longer bolts may be required if the bracket thickness is greater than 8 mm

For channel nuts, see p. 101

Channel type	Backplate thickness	Recommended fasteners ⁽¹⁾
Deep channel SC400 series	6 mm and 8 mm	M10 or M12 x 35 mm ⁽²⁾
	5 mm and 6 mm	M10 or M12 x 20 mm
Shallow channel SC200 series	7 mm and 8 mm	M10 or M12 x 25 mm ⁽²⁾
	5 mm and 6 mm	M10 or M12 x 20 mm

(1) The use of too long a fastener will prevent proper tightening because the bolt end will foul the bottom of the channel before the head tightens down on the fitting

(2) When fastener brackets other than Swiftrack, longer bolts may be required if the bracket thickness is greater than 8 mm

■ 90° brackets

SB500

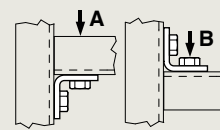
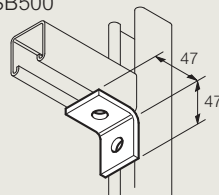

Maximum load on each bracket with both ends supported : A = 350kgf. B = 174kgf
 Unit weight (kg) : 0.125

SB501

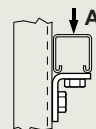
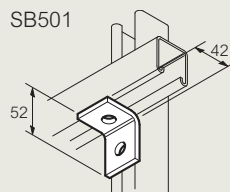

Maximum load on each bracket :
 A = 180kgf
 Unit weight (kg) : 0.125

SB502

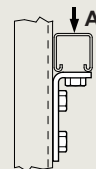
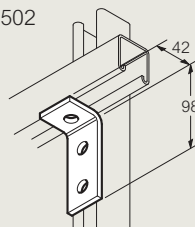

Maximum load on each bracket :
 A = 230kgf
 Unit weight (kg) : 0.191

SB503

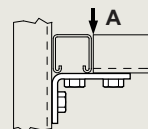
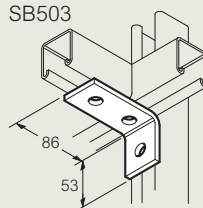

Maximum load on each bracket with both ends supported : A = 120kgf
 Unit weight (kg) : 0.191

SB504

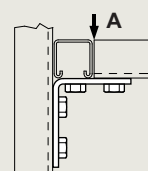
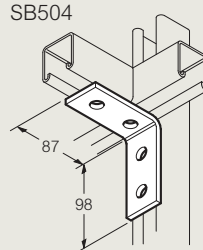

Maximum load on each bracket :
 A = 120kgf
 Unit weight (kg) : 0.257

SB505

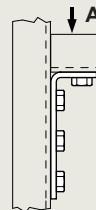
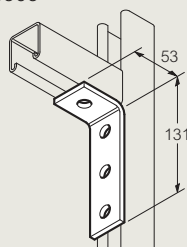

Maximum load on each bracket :
 A = 300kgf
 Unit weight (kg) : 0.257

All dimensions (mm) are nominal

Swiftrack® channel support system framework brackets (continued)

■ 90° brackets (continued)

SB550

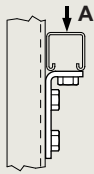
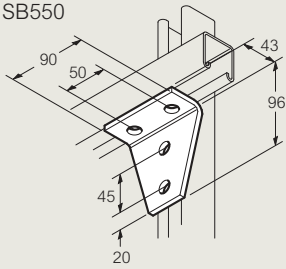

Maximum load on each bracket :
A = 600kgf
Unit weight (kg) : 0-359

SB551

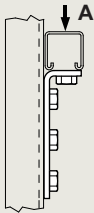
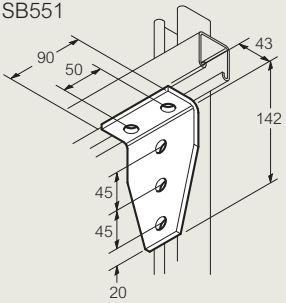

Maximum load on each bracket :
A = 600kgf
Unit weight (kg) : 0-516

SB552

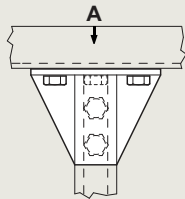
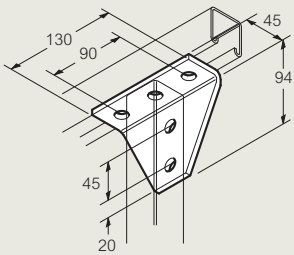

Maximum load on each bracket :
A = 700kgf. 5mm thick.
Unit weight (kg) : 0-488

SB556

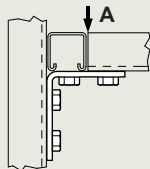
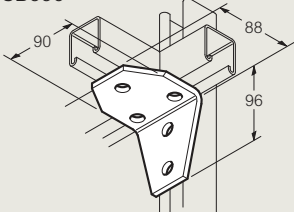

Maximum load on each bracket with
both ends supported : A = 260kgf
Unit weight (kg) : 0-478

■ Square plates and splice plates

Square plates

Cat. Nos.	Fasteners	Unit weight (kg)
SB50606	M6	0-063
SB50608	M8	0-062
SB50610	M10	0-061
SB50612	M12	0-058

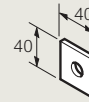

Use as location plate when attaching any special fitment which will not sit across both channel sides

Splice plates

Holes spaced at 45 mm centres

SB507

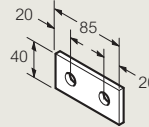

Unit weight (kg) : 0-125

SB508

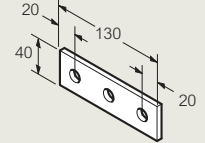

Unit weight (kg) : 0-191

SB509

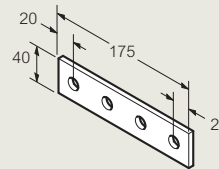

Unit weight (kg) : 0-257

SB510

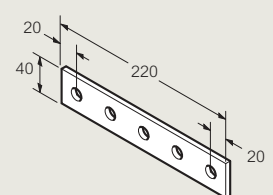

Unit weight (kg) : 0-323

■ U and Z brackets

U bracket

SB514

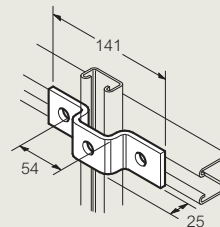

Unit weight (kg) : 0-243

SB515

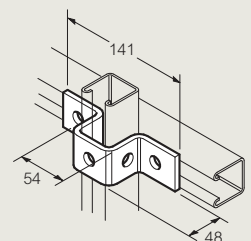

Hole on one side of bracket only
Unit weight (kg) : 0-307

Z bracket

SB511

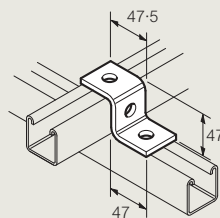

Unit weight (kg) : 0-179

SB513

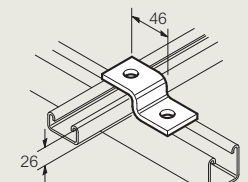

Unit weight (kg) : 0-150

All dimensions (mm) are nominal

Swiftrack® channel support system

framework brackets (continued)

■ Angle brackets and plates

Obtuse angle brackets

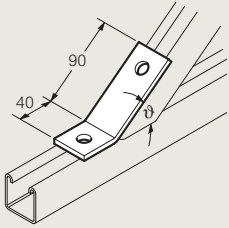

Cat. Nos.	Angle ϑ	Unit weight (kg)
SB520	15	0.197
SB524	45	0.197
SB526	60	0.197
SB528	75	0.197

Acute angle brackets

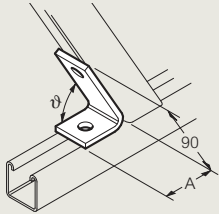

Cat. Nos.	Angle ϑ	A (mm)	Unit weight (kg)
SB532	45	65	0.237
SB534	60	46	0.197
SB536	75	46	0.197

■ T brackets and plates

T plate

SB554

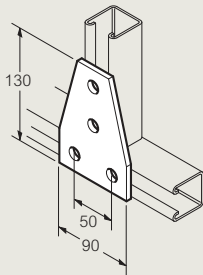

Unit weight (kg) : 0.359

SB555

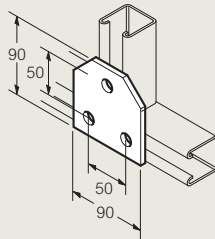

Unit weight (kg) : 0.284

T bracket

SB603

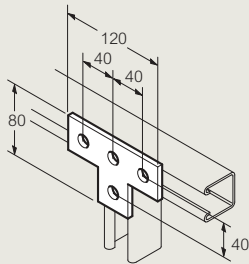

Unit weight (kg) : 0.233

90° T bracket

SB606

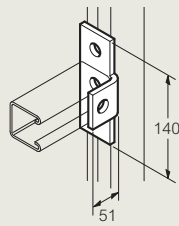

Unit weight (kg) : 0.32
Not available in S finish

Cross plate

SB603+

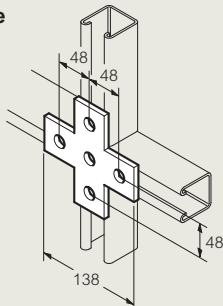

Unit weight (kg) : 0.35
Not available in S finish

45° T bracket

SB607

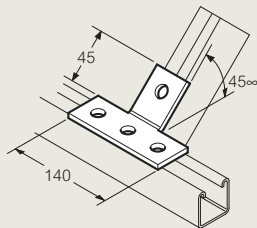

Unit weight (kg) : 0.32
Not available in S finish

■ Joining brackets and channels

Joining bracket

SB518

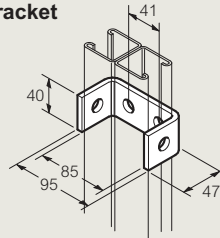

Unit weight (kg) : 0.249

Joining channel

SB651

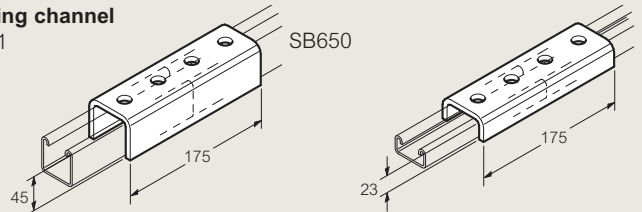

For SC400 channel. 45 mm deep
Unit weight (kg) : 0.85

For SC200 channel. 23 mm deep
Unit weight (kg) : 0.55

■ L brackets

L bracket

SB600

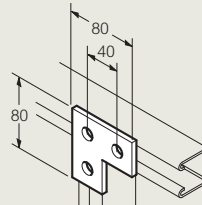

Unit weight (kg) : 0.163

Left hand

L corner bracket

SB602

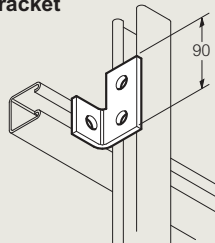

Unit weight (kg) : 0.27
Not available in S finish

Right hand

L corner bracket

SB601

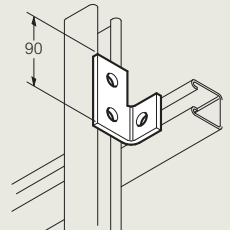

Unit weight (kg) : 0.27
Not available in S finish

Swiftrack® channel support system

framework brackets (continued) and beam clamps

Wing brackets and shelf brackets

2 lug wing bracket
SB700

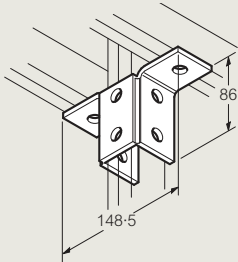

Unit weight (kg) : 0.492

3 lug wing bracket
SB701

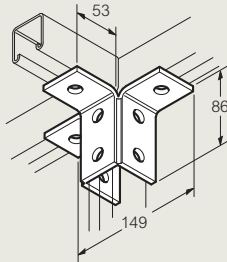

Unit weight (kg) : 0.581

Angled wing bracket
SB707

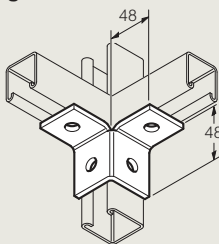

Unit weight (kg) : 0.250
Not available in S finish

Shelf bracket
SB703

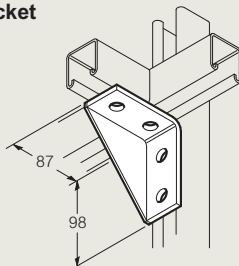

Gusset only, 3 mm thick
Unit weight (kg) : 0.369

Base plates and gusseted brackets

Single channel base plate
SB704

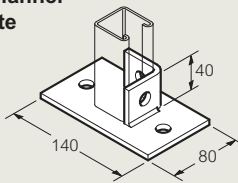

Distance between hole centres : 100 mm
Unit weight (kg) : 0.618

Double channel base plate
SB705

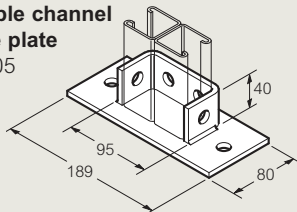

Distance between hole centres : 149 mm
Unit weight (kg) : 0.848

Single channel gusseted bracket
SB702

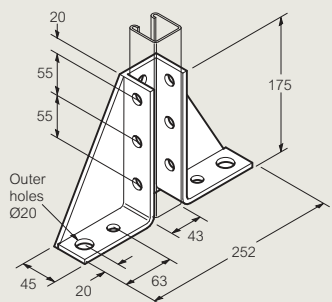

Unit weight (kg) : 1.848

Double channel gusseted bracket
SB706

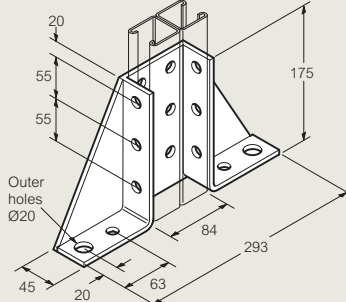

Unit weight (kg) : 2.118

All dimensions (mm) are nominal

Beam clamps

Beam clamps are supplied singly
Nut, bolts, cone point screws and U bolts where shown are included
Beam clamps conform to BS 6946

Dimensions and weights

All weights given are in kilograms (kg) based on nominal thickness and are for hot dip galvanised finish unless otherwise stated. For weights in stainless steel finish contact us on +44 (0) 845 605 4333

Beam clamp
SC850

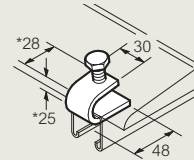

6 mm
Maximum load : 400kgf/pair
Use in pairs
Not available in S finish
Unit weight (kg) : 0.117

Beam clamp
SC851

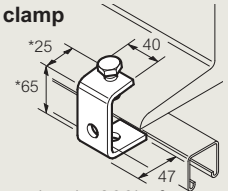

6 mm
Maximum load : 200kgf
Unit weight (kg) : 0.208

Window beam clamp
SC852/21

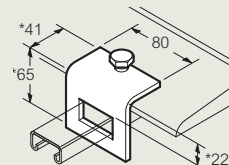

6 mm
For 21 mm channel
Maximum load : 475kgf/pair
Use in pairs
Unit weight (kg) : 0.37

Window beam clamp
SC852/41

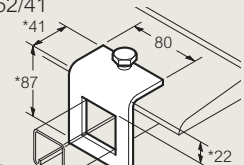

6 mm
For 41 mm channel and 21 mm back-to-back channels
Maximum load : 475kgf/pair
Use in pairs
Unit weight (kg) : 0.52

Window beam clamp
SC852/82

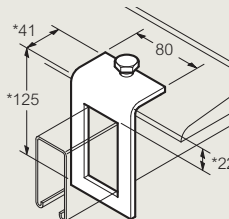

6 mm
For 41 mm back-to-back channels.
Maximum load : 375kgf/pair
Use in pairs
Not available in S finish
Unit weight (kg) : 0.56

Beam clamp
SC853

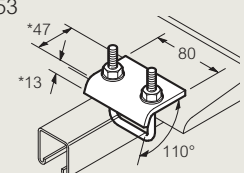

Maximum load : 900kgf/pair
Use in pairs
Unit weight (kg) : 0.30

Beam Clamp
SC854

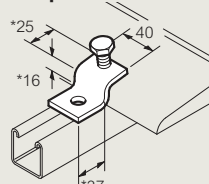

6 mm
Maximum load : 350kgf/pair
Use in pairs
Unit weight (kg) : 0.17

(*) Inside dimensions (mm)

Swiftrack® channel support system

beam clamps, pipe clamps and channel accessories

■ Beam clamps (continued)

Beam clamp
SC855

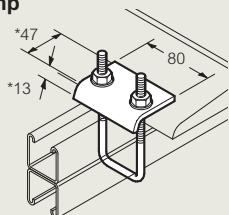

Maximum load : 900kgf/pair
Use in pairs
Unit weight (kg) : 0.308

Toe beam clamp
SC856

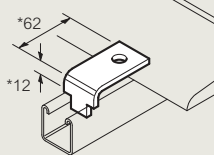

6 mm
Maximum load : 400kgf/pair
Use in pairs
Requires 2 setscrews and channel nuts for fixing (not included)
Unit weight (kg) : 0.179

Beam Clamp
ZC1

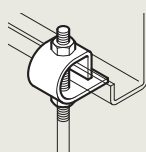

Maximum load : 25kg
Use M10 Rod
Zinc plated to BS 3382 : Part 2
Unit weight (kg) : 0.10

Beam Clamp
FL2

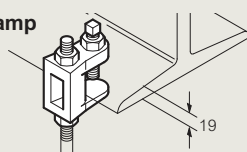

Maximum load : 240kg
Use M10 Rod
Zinc plated to BS 3382 : Part 2
Not available in S finish
Unit weight (kg) : 0.15

■ Pipe clamps

Supplied singly
Nuts and bolts where shown are included
Pipe clamps conform to BS 6946

Dimensions and weights

All weights given are in kilograms (kg) based on nominal thickness and are for hot dip galvanised finish unless otherwise stated. For weights in stainless steel finish contact us on +44 (0) 845 605 4333

SP960 - SP973

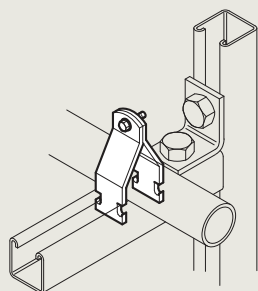

Cat. Nos.	Pipe diameter (mm)	Unit weight (kg)
SP960	10-14	0.06
SP964	17-22	0.08
SP965	22-26	0.09
SP968	25-36	0.10
SP969	32-42	0.11
SP972	42-59	0.13
SP973	54-65	0.15

SP975 - SP976

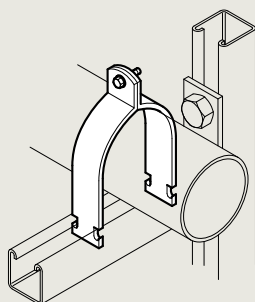

Cat. Nos.	Pipe diameter (mm)	Unit weight (kg)
SP975	62-71	0.16
SP976	73-83	0.17

■ Channel accessories

Channel accessories conform to BS 6946

Dimensions and weights

All weights given are in kilograms (kg) based on nominal thickness and are for hot dip galvanised finish unless otherwise stated. For weights in stainless steel finish contact us on +44 (0) 845 605 4333

Channel end caps	
Cat. Nos.	Finish
SC950B	black
SC950W	white

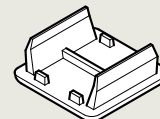

For SC400, SC401 and SC403 channels
Supplied in packs of 100
Weight per 100 (kg): 0.9

Channel end caps	
Cat. Nos.	Finish
SC951B	black
SC951W	white

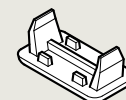

For SC200, SC201 and SC203 channels
Supplied in packs of 100
Weight per 100 (kg) : 0.9

Closure strips	
Cat. Nos.	Finish
SC952	plastic
SC953	metal

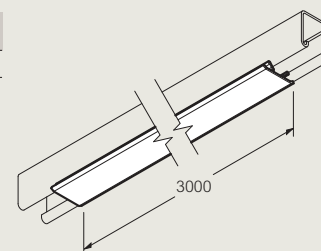

Standard length 3 metres
Unit weight (kg) : SC952 : 0.4
SC953 : 1.0

■ Finishes and standards

The standard finish for pipe clamps is pre-galvanised steel to BS EN 10327 – grade DX51D and Z275 finish
Stainless steel to BS EN 10088 : Grade 1.4404 (equivalent to S316L31) is also available as an alternative

All dimensions (mm) are nominal

Ceiling support system

heavy duty

The dedicated ceiling support system allows for a flexible, multi-tiered approach for single or double sided loads with a maximum cantilever arm width of 700 mm to accept Swifts cable ladders up to 600 mm wide, either lidded or unlidded

Ceiling fixings are not included

Cantilever arms will accept the following maximum width items :

Cat. Nos.	Width (mm)	
557233	200	150 mm unlidded ladder
557243	300	150 mm lidded or unlidded ladder
557253	400	300 mm lidded or unlidded ladder
557263	500	450 mm unlidded ladder
557273	600	450 mm lidded ladder
557383	700	600 mm lidded or unlidded ladder

■ Ceiling supports

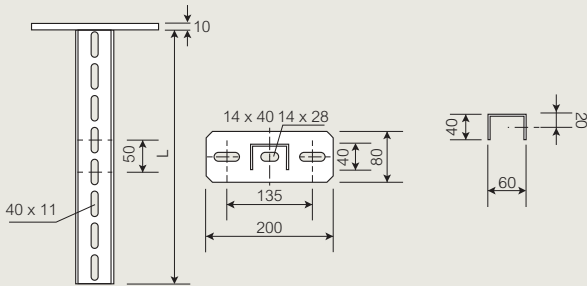

Ceiling supports		
Cat. Nos.	Weight (kg)	Load (kn)
8766502	1.318	6
8766503	1.630	6
8766504	1.942	6
8766505	2.254	6
8766506	2.566	6
8766507	2.878	6
8766508	3.190	6
8766509	3.502	6
8766510	3.814	6
8766511	4.126	6
8766512	4.438	6
8766513	4.750	6
8766514	5.062	6
8766515	5.374	6
8766516	5.686	6
8766518	6.310	6
8766520	6.934	6

■ Extension profiles

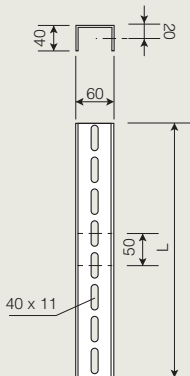

Extension profiles	
Cat. Nos.	Weight (kg)
8766530	9.600
8766545	14.400

■ Ceiling bracket

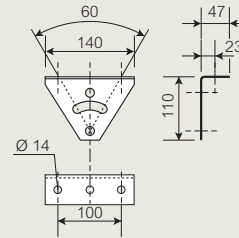

Ceiling bracket	
Cat. No.	Weight (kg)
8766550	0.500

■ End plate profile

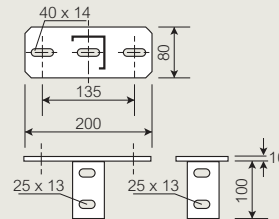

End plate profile	
Cat. No.	Weight (kg)
8766560	0.970

■ Profile connector

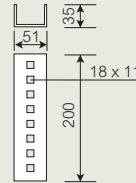

Profile connector	
Cat. No.	Weight (kg)
8766570	0.418

■ Cantilever arms

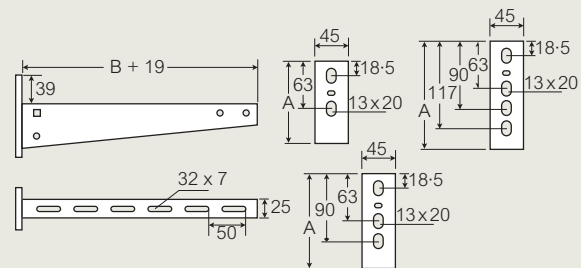

100 – 400 back plate = 4 mm
500 – 700 back plate = 6 mm

Cantilever arms				
Cat. Nos.	Weight (kg)	Load (kn)	A (mm)	B (mm)
557233	0.335	3	103	200
557243	0.464	3	111	300
557253	0.637	3	121	400
557263	0.782	3	128	500
557273	1.110	3	138	600
557383	1.438	3	146	700

■ Finish

G S235J hot dip galvanised steel to BS EN ISO 1461

For further technical information, please contact us on +44 (0) 845 605 4333

All dimensions (mm) are nominal

DESIGN NOTES





IN THIS SECTION

Selecting the right finish

Preventing corrosion	
- Chemical corrosion	112
- Electrochemical corrosion	112
- Galvanic Series	113
- The merits of Zinc	114-115
- Common corrosion situations	116
Suitability of finishes	
- Metallic finishes	116-117
- Organic finishes	116-117

Finishes

British standards	118
Hot dip galvanised (G)	119
Deep galvanised (D)	119
Pre-galvanised (PG)	120
Stainless steel (S)	120
Powder coated (E)	121

Installation of services

Cable ladder systems	
- Design factors to consider	122-128
- Recommended support locations	125-126
- 6 m lengths over long spans	128-129
- Loading graphs	130-131

Structural support characteristics

Structural characteristics	
- Cable ladder	132
- Beams	132-133
- Columns	133
- Deflection	133
Designing a support system	
- Ceiling to floor applications	134
- Ceiling mounted applications	135
- Wall mounted applications	135
- Floor mounted applications	135
Swiftrack channel support	
- Channels	136
- Channel nuts	136
- Framework brackets	136
- Fasteners	136
- Cantilever arms	137
- Maximum safety recommended loadings	137
- Channels used as beams	138
- Channels used as columns	138
- Fully restrained and unrestrained loads	138
- Beam loads	139

Packaging, handling, storage and safety

Export packaging	140
Handling and storage	141
Safety during installation phase	141

Relevant British, European and International Standards

142-143

Selecting the right finish

IN THIS SECTION...

Preventing corrosion

1. Chemical corrosion
2. Electrochemical corrosion
3. Galvanic Series
4. The merits of Zinc
5. Common corrosion situations

Suitability of finishes

1. Metallic finishes
2. Organic finishes

Preventing corrosion

In planning any cabling or support installation the choice of an appropriate corrosion resistant finish is always a key issue at the specification stage, ranking alongside installation time and load carrying ability. However, unlike these other factors, which are only of importance during the installation phase, the correct choice of finish has long term implications and is crucial for ensuring the longevity (and aesthetics) of the complete installation in order to meet with the client's expectations.

Since future maintenance of any support system is virtually impossible, it is vital that the finish specified for the equipment is capable of providing lifetime protection from corrosion within the intended environment - ideally with some margin of safety.

The following pages give information on how corrosion occurs and supporting technical data on the standard construction materials and surface finishes available within each range of products supplied by Legrand. Contact our technical team on +44 (0) 845 605 4333 for further information.

Corrosion occurs on all metals to some extent. With some, such as stainless steel, its effects are usually only slight but even then the presence of certain chemicals or physical contact with other metals may cause rapid corrosion. It is therefore important to consider every aspect of the environment surrounding any intended installation in order to choose a material or finish which will minimise the risk of damage to the support system through the effects of corrosion.

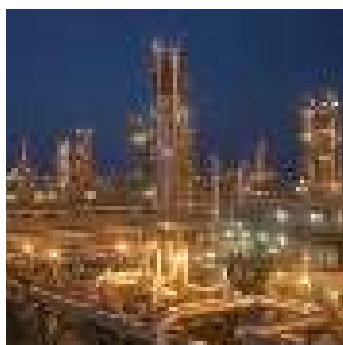

1 Chemical corrosion

Few metals will suffer corrosion damage in a dry, unpolluted atmosphere at a normal ambient temperature. Unfortunately such environments are exceptional and atmospheric pollutants are likely to be present to some degree in most situations where support systems will be installed. Thus mild chemical corrosion is normal in almost all situations and useful information on the types of material or choices of finish which will inhibit and control this are given within the following pages.

Any support installation which will be situated in an area where higher concentrations of chemicals exist must receive more detailed consideration in order to select a finish which provides the best combination of initial cost and expected life. To assist in this, tables on page 117, give guidance on the suitability of the standard materials and finishes used for support systems in the presence of those chemicals most commonly found within industry. More detailed information is available upon request, please contact us on +44 (0) 845 605 4333.

2 Electrochemical corrosion

When two dissimilar metals are in contact and become damp it is possible for corrosion to be induced in one of the metals. Such corrosion may progress rapidly and cause considerable damage so it is important to consider and, if necessary, take steps to eliminate this process occurring.

Electrochemical (or electrolytic) corrosion takes place because the two different metals each behave as electrodes and the moisture as the electrolyte in a simple battery; as with any battery the resulting flow of current will cause corrosion of the anode.

The likely effects of this reaction can be predicted using the Galvanic Series.

3 Galvanic Series

Even when two dissimilar metals are in moist contact, electrochemical corrosion need not necessarily take place. Its likelihood depends upon the potential difference between the two metals; this can be obtained by taking their respective values from the chart below and subtracting one from the other.

When the potential difference is less than the values given in the table to the right corrosion is unlikely to occur.

Environment	Maximum Potential Difference
Marine and outdoor	0.3 volts
Indoor	0.5 volts
Indoor, hermetically sealed (dry)	No restriction ⁽¹⁾

(1) With no moisture to act as the electrolyte no electrochemical corrosion can take place

If corrosion does take place the metal which is higher in the Series (to the right) will be corroded in preference to that which is lower in the Series (to the left).

Galvanic Series chart

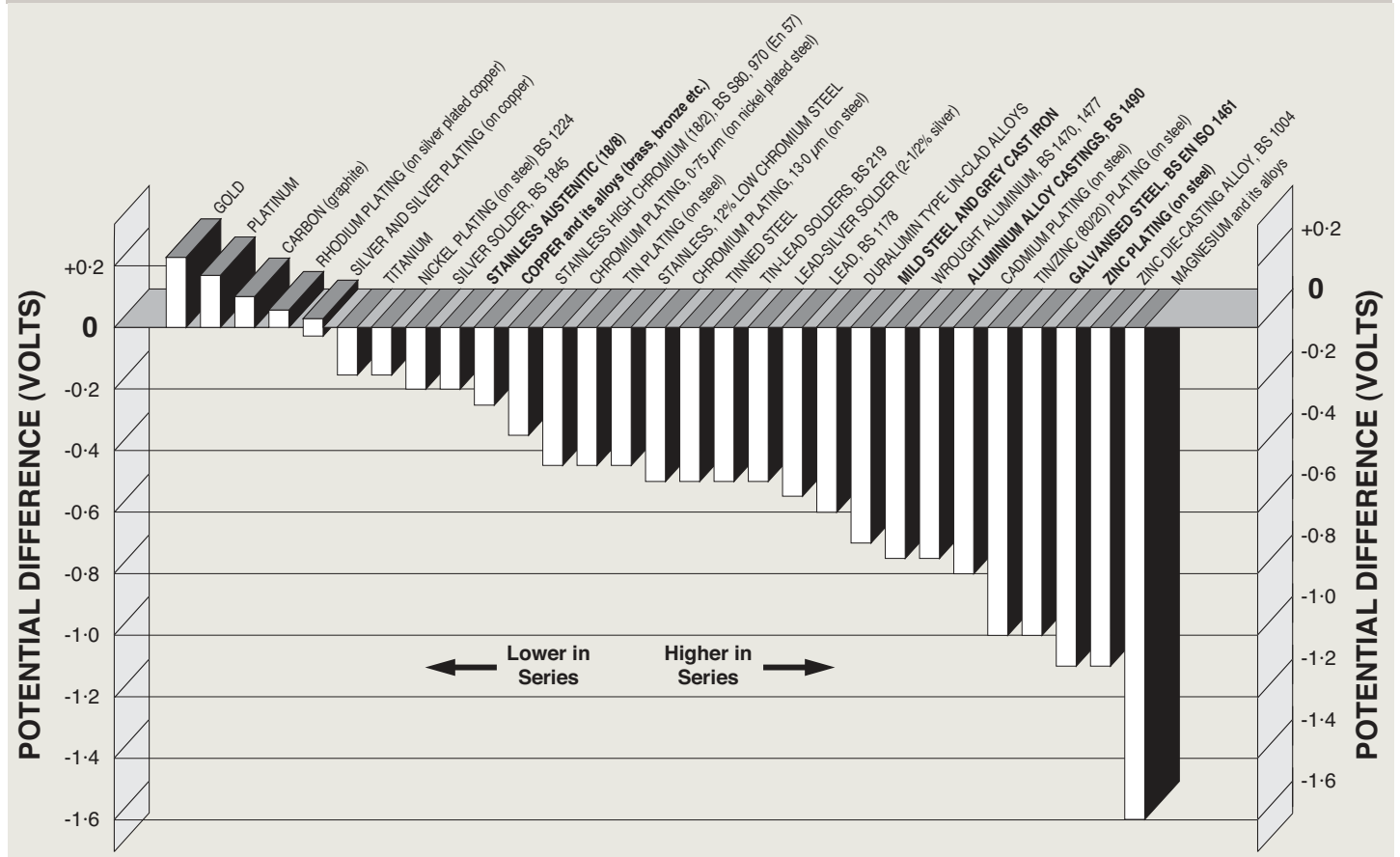

The Galvanic Series illustrates the potential difference between a section of metal and a Calomel electrode when both are immersed in sea water at 25°C. This chart contains most commonly used engineering or plating metals.

If corrosion does take place the metal which is higher in the series (to the right) will be corroded in preference to that which is lower in the series (to the left).

If the affected metal has a small surface area in relation to its counterpart it will be corroded very aggressively and any sacrificial protection it provides may be short-lived. If on the other hand it has a large surface area in comparison to its less reactive counterpart, some minor corrosion may take place at points of contact but the process is likely to reach equilibrium rapidly so that any further reaction is insignificant.

If from consideration of this Series excessive corrosion does appear likely then the risk can be largely eliminated by insulating the dissimilar metals from one another, breaking the electrical path between them. A layer of paint on either surface is usually sufficient to achieve this.

4 The merits of Zinc

The Galvanic Series does show why zinc is such a useful corrosion resistant coating for mild steel.

Firstly, it forms an impervious zinc barrier around the steel, coating it with a metal whose own rate of chemical corrosion is both low and predictable in most situations.

Secondly, if the coating is damaged at any point (e.g. at a cut edge) the zinc surrounding the damaged area becomes the anode of the electrolytic cell and is sacrificially corroded away very slowly in preference to the underlying steel. This ensures the strength of the steel structure remains unaffected.

Because zinc appears near the top of the Galvanic Series it will act as a sacrificial anode in relation to most other metals; thus its relatively low cost and the ease with which it can be applied as a galvanised coating on steel means that it continues to be the most commonly specified protective finish for support systems.

Life expectancy of zinc coatings

The resistance of galvanising to atmospheric corrosion depends on a protective film which forms on the surface of the zinc. When the steel is withdrawn from the galvanising bath the zinc has a clean, bright, shiny surface. Over time the appearance will change to a dull grey patina as the surface reacts with oxygen, water and carbon dioxide in the atmosphere. A complex but tough, stable and protective layer is formed which adheres to the zinc. Contaminants in the atmosphere affect the nature of this protective film.

The most significant contaminant which will accelerate the corrosion rate of zinc is sulphur dioxide (SO₂) and it is the presence of SO₂ which largely controls the atmospheric corrosion of zinc.

The Galvanizers Association has undertaken significant research based upon the positioning of reference canisters placed throughout the UK and the Republic of Ireland to establish background corrosion rates for 10 km square grids which has resulted in the formation of The Zinc Millennium Map.

For most sites on this map an average hot dip galvanised coating will last between 40 to 100 years, highlighting the potential for significant financial savings when galvanising is specified. However, with the correct use of the map specific locations can be analysed for average zinc corrosion rates per year.

The Zinc Millennium Map

The definitive geographical guide to the different corrosion levels of galvanised steel products used in the construction industry

Corrosion rate key	1	2	3	4	5
Average Corrosion rate (µm/year)	0.5	1	1.5	2	2.5
Average life of 85µm galvanised coating (years)	187	85	57	43	34

Please note this is an average background corrosion rate for zinc. For further information please contact the Galvanizers Association

BS EN ISO 14713 general corrosion effects and life expectancy for zinc coated products

Corrosivity category	Corrosion rate of	Environment - interior	Environment - exterior	Pollution level	Zinc coating thickness	Coating life years										
						10	20	30	40	50	60	70	80	90	100	
C1	< 0.1 Very low	Warm, dry, no pollution		0	PG (Z275) = 19 microns											> 100
					G = 55 microns											> 100
					D = 110 microns											> 100
C2	0.1 to 0.7 Low	Unheated, low condensation, low pollution	Temperate, rural, urban with low pollution	<5	PG (Z275) = 19 microns											> 100
					G = 55 microns											> 100
					D = 110 microns											> 100
C3	0.7 to 2 Medium	Moderate condensation & pollution eg food processing plants	Temperate, urban with medium pollution, mild coastal	5 to 30	PG (Z275) = 19 microns											> 100
					G = 55 microns											> 100
					D = 110 microns											> 100
C4	2 to 4 High	High condensation, high pollution eg chemical or industrial plants,	Temperate, urban with high pollution, industrial, coastal	30 to 90	PG (Z275) = 19 microns											> 100
					G = 55 microns											> 100
					D = 110 microns											> 100
C5	4 to 8 Very high	Very high condensation & industrial pollution, eg mines	Temperate, very high pollution, industrial & high salinity coastal	90 to 250	PG (Z275) = 19 microns											> 100
					G = 55 microns											> 100
					D = 110 microns											> 100
CX	8 to 25 Extreme	Permanent condensation & high pollution	Very high pollution, extreme industrial, coastal & offshore with occasional salt	>250	PG (Z275) = 19 microns											> 100
					G = 55 microns											> 100
					D = 110 microns											> 100

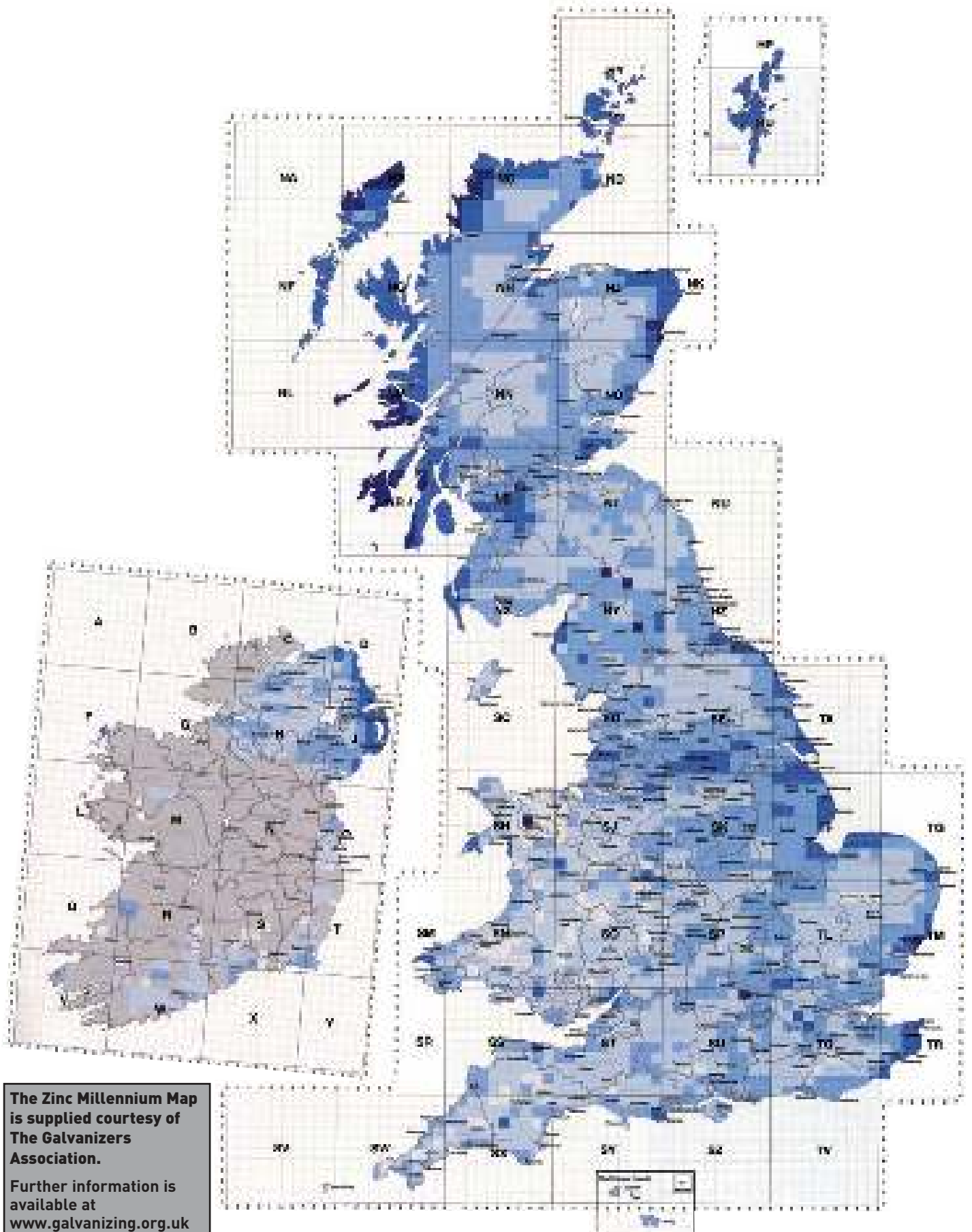

The Zinc Millennium Map is supplied courtesy of The Galvanizers Association.

Further information is available at www.galvanizing.org.uk

5 Common corrosion situations

Finally, the most common occurrences of contact between dissimilar metals within support systems are :

- a. Where stainless steel components are being fixed to a carbon steel structure
- b. Where galvanised or zinc plated components are being fixed onto a stainless steel support system
- c. Where copper components (e.g. copper tubing or MICC cable) are being installed onto a galvanised steel support system

In relation to these three sets of conditions the following comments apply :

(i) Stainless steel – mild steel

This situation has been the subject of much consideration and debate over recent years, particularly in the offshore energy industry.

Whilst Legrand can supply kits of components (including, according to the circumstances, insulating pads, sleeves for fasteners or insulating coatings) the latest metallurgical advice from both the manufacturers of stainless steel and other bodies is that these metals are sufficiently close together in the Galvanic Series for any electrolytic effects to be ignored in normal offshore environments. One exception is when a small mild steel (or galvanised mild steel) component is in direct contact with a large mass of stainless steel.

It is now accepted that the application of a simple paint coating to one of the juxtaposed surfaces will provide sufficient insulation to break the electrical circuit, effectively eliminating any problems.

(ii) Small galvanised components on stainless steel

The zinc coating will provide very limited protection to its underlying steel because of the rapidity with which it will erode away. Once exposed the base steel (often a fastener) will be aggressively corroded causing unsightly staining of the stainless steel and premature failure to the component. In the case of fasteners such failure could be catastrophic to the installation so appropriate stainless steel fasteners should always be used with a stainless steel support system.

(iii) Copper on zinc

If copper is laid directly onto a galvanised surface the zinc will rapidly erode. Thus MICC cable should always have an insulating sheath if it is to be installed on galvanised cable ladder.

Suitability of finishes

1 Metallic finishes

The table on the following page outlines the suitability of metallic finishes under a variety of conditions. The following notes apply to the data :

1. Hard water promotes the formation of a stable protective film on a hot dip galvanised coating.
2. Salt spray testing should not be used on galvanised coatings; the data provided by such accelerated weathering tests is misleading and inaccurate on this finish since the formation of the protective film (patina) is prevented from forming under the artificial conditions.
3. No information is available on the resistance of galvanised coatings to contact with this type of oil. However, in general terms galvanised coatings are resistant to oil-based products.
4. Resistant provided that the oil is stable, free from acidity and of mineral origin.
5. Under immersed conditions contact with this chemical is not recommended and over-coating with a paint or powder system is necessary. When this chemical is an airborne aerosol the coating performance depends on various factors specific to the particular application. Corrosion rates will be high and if condensation is likely to be heavy and its pH value is outside the range pH5 - pH12.5 then overpainting or coating of the galvanising is normally recommended.

If the galvanised surface is frequently washed by fresh water and allowed to periodically dry out then the level of corrosion will be less severe.

2 Organic finishes

Refer to the table on the following page for information on the suitability of organic finishes under a variety of conditions.

Suitability of metallic finishes

		Stainless steel 316	Stainless steel 304	Pre-galvanised steel	Hot dip galvanised steel	Deep galvanised steel	Aluminium
ENVIRONMENTS	Fresh water	✓	✓	×	✓ see note (1)	✓ see note (1)	
	Salt spray B177 Test	✓	✓	×	✓ see note (2)	✓ see note (2)	✓
	Polluted marine environment	✓	×	×	✓	✓	0
SOLVENTS	Acetone	✓	✓		✓	✓	✓
	Petroleum (gasoline)	✓	✓		✓	✓	✓
	Trichloroethylene	✓	✓		✓	✓	
	Glycerine	✓	✓		✓	✓	
	Methyl chloride	✓	✓		✓	✓	0
OILS	Linseed oil	✓	✓	0 see note (3)	0 see note (3)	0 see note (3)	
	Penetrating oil	✓	✓	0 see note (3)	0 see note (3)	0 see note (3)	
	Lubricating oil	✓	✓	0 see note (5)	0 see note (4)	0 see note (4)	
ACIDS	10% Sulphuric acid	×	×	0 see note (5)	0 see note (5)	0 see note (5)	×
	Conc. Sulphuric acid	✓ X at high temp.	✓ X at high temp.	0 see note (5)	0 see note (5)	0 see note (5)	✓ X above 40°C.
	10% Hydrochloric acid	×	×	0 see note (5)	0 see note (5)	0 see note (5)	×
	10% Nitric acid	✓	✓	0 see note (5)	0 see note (5)	0 see note (5)	✓
	50% Phosphoric acid	✓	×	0 see note (5)	0 see note (5)	0 see note (5)	×
	10% Acetic acid	✓	✓	0 see note (5)	0 see note (5)	0 see note (5)	
	5% Tartaric acid	✓	0	0 see note (5)	0 see note (5)	0 see note (5)	×
	5% Citric acid	✓	✓ X at high temp.	0 see note (5)	0 see note (5)	0 see note (5)	×
10% Lactic acid	✓	×	0 see note (5)	0 see note (5)	0 see note (5)		
ALKALINES	10% Caustic soda sodium hydroxide	✓	×	0 see note (5)	0 see note (5)	0 see note (5)	
	25% Caustic soda	✓	×	0 see note (5)	0 see note (5)	0 see note (5)	×
	10% Ammonia	0	0	0 see note (5)	0 see note (5)	0 see note (5)	

KEY : ✓ Probably suitable ● × Probably unsuitable ● 0 Investigate if no alternative

For notes (1) to (5) see left hand page

Suitability of organic finishes

		Epoxy powder	Polyester epoxy mix coating	PVC coating	GRP polyester	GRP vinyl ester	PVC
ENVIRONMENTS	Fresh water	✓	✓	✓	✓	✓	✓
	Salt spray B177 Test	✓	✓ 500 hours	✓ 500 hours	0	0	✓
	Polluted marine environment	×	×	×	×	✓	×
SOLVENTS	Acetone	×	✓	×	×	×	×
	Petroleum (gasoline)	✓	✓	✓ X above 75°C.	✓ X above 60°C.	✓	✓ X above 75°C.
	Trichloroethylene	×	✓	×	×	×	×
	Glycerine	✓	✓	✓ X above 75°C.	✓	✓	✓ X above 75°C.
	Methyl chloride	×	✓	×	×	×	×
OILS	Linseed oil	✓	✓	✓ X above 75°C.	✓	✓	✓ X above 75°C.
	Penetrating oil	✓	✓	✓ X above 75°C.	✓	✓	✓ X above 75°C.
	Lubricating oil	✓	✓		✓ X above 60°C.	✓	
ACIDS	10% Sulphuric acid	✓	✓	✓ X above 75°C.	✓	✓	✓ X above 75°C.
	Conc. Sulphuric acid	×	×	×	×	✓	×
	10% Hydrochloric acid	✓	✓	✓ X above 30°C.	✓ X above 60°C.	✓	✓ X above 30°C.
	10% Nitric acid	×	✓ X above 20°C.	✓ X above 30°C.	×	✓ X above 50°C.	
	50% Phosphoric acid	✓	✓	✓ X at high temp.	✓	✓	✓ X above 75°C.
	10% Acetic acid	✓	✓	×	✓	✓	
	5% Tartaric acid	✓	✓	✓ X above 75°C.	✓	✓	×
	5% Citric acid	✓	✓	✓	✓	✓	✓ X above 75°C.
10% Lactic acid	✓	✓	✓	✓ X above 60°C.	✓	✓ X above 75°C.	
ALKALINES	10% Caustic soda sodium hydroxide	✓	✓	✓	×	✓	✓ X above 75°C.
	Caustic soda	✓	✓	✓ X above 75°C.	×	×	
	10% Ammonia	✓	✓	✓	×	✓ X above 35°C.	✓ X above 75°C.

KEY : ✓ Probably suitable ● × Probably unsuitable ● 0 Investigate if no alternative

Finishes

IN THIS SECTION...

1. British standards
2. Hot dip galvanised (G)
3. Deep galvanised (D)
4. Pre-galvanised (PG)
5. Stainless steel (S)
6. Powder coated (E)

Available on cable ladder and Swiftrack support systems

1 British standards

Legrand ensures that all of the materials used during the construction and finishing of their products conform to the relevant standards, a full list of which is provided on see p. 142.

In particular, the relevant standards for steel are :

Finish	Product	Current standard/grade
G	Ladder less than 1.5mm thick	BS EN 10130 : 2006 Grade DC01
G	Ladder 1.5mm and thicker	BS EN 10111 : 1998 Grade 1.0332 / BS EN 10025 : 2004 Grade S275JRC
G	Swiftrack channel	BS EN 10025 : 1993 Grade S235JRC (Ys = 250N/mm ² min)
G	Swiftrack brackets	BS EN 10025 : 2004 Grade S275JRC
PG	Swiftrack channel	BS EN 10346 : 2009 Grade S250GD + Z275
D	Ladder	BS EN 10025-5 : 2004 Grade S355JOWP
S	Ladder and Swiftrack	BS EN 10088 : 2005 Grade 1.4404 (equivalent to S316L31)

Finishes :

G = hot dip galvanised after manufacture

PG = pre-galvanised

D = deep galvanised

S = stainless steel

E = powder coated

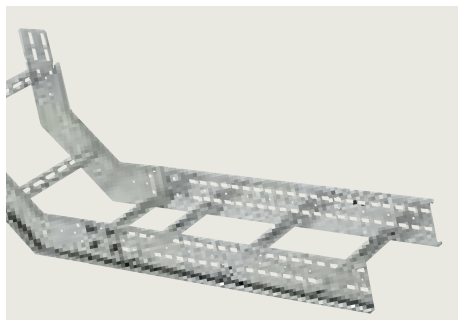

Heavy duty (Sapphire) length shown in G finish
See p. 16

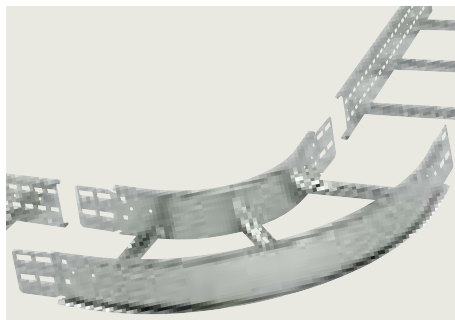

Heavy duty (Sapphire) bend shown in G finish
See p. 16

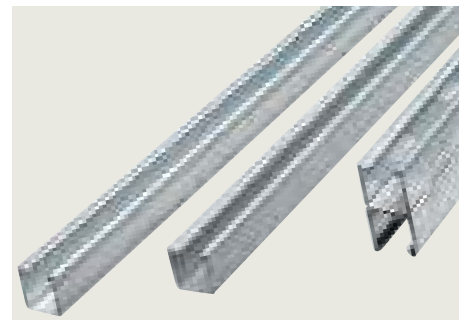

Swiftrack channel support shown in PG finish
See p. 25

2 Hot dip galvanised (G)

Hot dip galvanising after manufacture is an excellent, economical protective finish used on support systems in many industrial and commercial applications.

Background

The galvanised coating is applied as a final manufacturing process by immersing a steel component (after various pre-treatments) in a large bath of molten zinc; the zinc forms an alloy with the steel substrate and protects the steel from corrosion in two ways.

Firstly, the zinc coating surrounds the base steel with a total, tough physical barrier preventing corrosion of the steel by the surrounding atmosphere. Secondly, if steel does become exposed, e.g. at a cut edge, the zinc coating acts as a sacrificial anode and will be gradually corroded in preference to the underlying steel. Corrosion products from the zinc will also be deposited onto the steel, effectively re-sealing the surface and maintaining the integrity of the barrier.

The life of a zinc coating is directly proportional to its thickness but in different environments this life does vary. However because hot dip galvanising has been used for many years its life in diverse environments has been well established. The most comprehensive guide to the design life of protective systems in different environments is contained in BS EN ISO 12944-5 : 2007 'Paints and varnishes' and BS EN ISO 14713 : 2009 'Parts 1 + 2 - zinc coatings'. In the presence of certain atmospheric pollutants (such as sulphur dioxide in industrial areas) or when installed in an aggressive coastal or marine environment the rate of dissipation of the zinc will be accelerated; however in most situations hot dip galvanising remains an extremely effective and economical corrosion resistant finish.

Specification

BS EN ISO 1461 provides the specification for a hot dip galvanised coating. Heavier gauges of steel will usually take up a thicker coating of zinc than lighter gauges so the standard defines the coating for different steel gauges in terms of the weight of zinc per square metre of surface area. Ensuring compliance with this standard is obviously important. Unfortunately it is not reasonable to use this weight principle for checking the coating weight on components which have already been galvanised as it involves calculating the surface area then weighing a component, destructively removing the coating by chemical means and then re-weighing the component. It is therefore usual to measure instead the coating thickness (which can be done non-destructively using magnetic or electronic instruments) at a number of points on the surface of a component. The coating thicknesses given in the standard and their equivalent coating weights are shown in table 1.

Table 1
Galvanising standard BS EN ISO 1461 : 2009
Minimum average zinc thickness

Steel thickness	Minimum average zinc thickness (microns)
Less than 1.5 mm	45
1.5 mm and thicker up to 3 mm	55
3 mm and thicker but less than 6 mm	70
6 mm and thicker	85

Note

For threaded and very small components which are spun galvanised, thinner coatings are used as recommended by BS EN ISO 1461.

It is important to distinguish between 'hot dip galvanised after manufacture to BS EN ISO 1461' and less precise descriptions such as 'galvanised', 'mill galvanised' or even the term 'hot dip galvanised', when used without reference to any standard. Mill galvanised steel is frequently used as an alternative finish for many support system components (see 'pre-galvanised steel', p. 120), and is available from Legrand, but this material does have a much thinner zinc coating which renders it unsuitable for exposed applications.

Suggested specification text : "All components should be hot dip galvanised after completed manufacture to the requirements of BS EN ISO 1461."

3 Deep galvanised (D)

A deep galvanised finish has all of the characteristics of hot dip galvanising but with a much thicker coating of zinc. This gives 2-3 times the life of the standard hot dip galvanised (BS EN ISO 1461) finish.

Background

The life of a galvanised coating depends very much upon the degree of pollution of the surrounding atmosphere; in an industrial or marine environment corrosion of the zinc may take place at double or treble the rate which would occur in an inland environment. Thus, if heavy atmospheric pollution or aggressive conditions exist in the vicinity of an installation, it is well worth considering the benefits provided by deep galvanising.

Since this finish is produced in the same basic process as normal hot dip galvanising the initial cost premium of the material is relatively low; however the site installation costs will remain unchanged. Therefore, for a relatively modest premium on the overall installed cost the life of the installation can be increased dramatically.

Specification

Although the appropriate British Standard for deep galvanising is BS EN ISO 1461 (the same as for hot dip galvanising after manufacture) the process requires the use of steel containing a slightly higher proportion of silicon; often referred to as high silicon steel. When galvanising normal mild steel the process effectively ceases after a short immersion time in the galvanising bath, giving, depending on the gauge of the steel, the coating thicknesses laid down within BS EN ISO 1461. However with silicon bearing steels the chemistry of the galvanising process changes, resulting in the zinc coating continuing to increase in thickness as long as the steel remains immersed in the zinc.

Coatings up to three times as thick as the minimum requirements of BS EN ISO 1461 are both possible and practical to achieve. However the most cost effective coating thickness is usually twice the thickness required by BS EN ISO 1461.

4 Pre-galvanised (PG)

A zinc coating can be economically applied to steel sheet immediately after its manufacture; the result, pre-galvanised steel (to BS EN 10346) can be an attractive, bright material which is suitable for non-arduous environments.

Background

Pre-galvanised (or mill galvanised) steel is produced by unwinding steel coil and passing it continuously through a bath of molten zinc and then past air jets to remove excess zinc from the surface. The process is closely controlled to produce a thin, even and ripple-free zinc coating with very few imperfections.

Because this pre-galvanised steel coil must then be cut to shape during subsequent manufacture of support equipment, the edges of the finished components will have no zinc coating; this aspect, together with the relatively light zinc coating provided by the process, make pre-galvanised services suitable for indoor, non-corrosive environments (particularly where an aesthetically attractive appearance is important) but unsuitable for humid indoor or outdoor applications.

Specification

For steel for Swiftrack channel, steel grade is BS EN 10346 : 2009 Grade S250GD + Z275

5 Stainless steel (S)

For all practical purposes most stainless steel services supports can be regarded as maintenance free and suffering no corrosion. Inevitably there is a relatively high price to pay for these attractive properties but, in aggressive environments or where the cost or inconvenience of gaining subsequent maintenance access is prohibitive, this initial cost premium may well be justified.

Background

Stainless steel contains a high proportion of chromium (usually at least 17%) and the steel's remarkable immunity to corrosive attack is conferred by the chromium-rich oxide film which occurs naturally on its surface. This invisible film is not only inert and tightly bonded to the surface, it also re-forms quickly if the surface is damaged in any way.

The fire resistance of stainless steel is particularly noteworthy; tests have demonstrated that stainless steel cable supports can be expected to maintain their integrity for considerable periods even when exposed to direct flame temperatures exceeding 1,000°C. This may be an important consideration where the electrical circuits being supported provide for emergency power or control systems.

Stainless steel is also used where hygiene is a major consideration. Its advantages in such applications are again its excellent resistance to the various chemicals and washes which are frequently used for cleaning purposes and the smoothness of surface (depending on the finish specified) which minimises the soiling or contamination that can take place.

Specification

Many grades of stainless steel are available but the one generally used in aggressive marine environments is BS EN 10088 Grade 1-4404 (equivalent to S316L31, BS 1449: Part 2). This grade has improved corrosion resistance (particularly in the presence of chlorides) and high temperature strength. It is much used in the chloride-laden marine conditions which exist on offshore installations and in coastal regions.

For less aggressive environments BS EN 10088 Grade 1-4301 (equivalent to 304, BS 1449: Part 2) is the normal grade. This grade offers good corrosion resistance in internal applications and also has a good aesthetic quality, often used in the dairy and food industries. Final finishes with mechanical brushing or polishing are often used to provide a good looking and robust surface finish.

Pickling and passivation

A stainless steel surface will have excellent corrosion resistance due to the chromium oxide layer on the surface of the product. With some stainless steels however, the surface areas can become subject to corrosion due to the depletion of chromium during welding, or the introduction of iron during a machining process (not applicable to most cable management products). Where a uniform appearance is important after carrying out welding processes, it is often specified that all surfaces should be pickled and passivated to remove the smoke stain from the welding process. Also where extreme corrosion resistance is called for, this process may help to remove crevice corrosion from around the welding area. Experience has shown that this is not normally necessary for the majority of cable management products.

Pickling

The pickling process involves the article being immersed in a blend of acids which dissolve iron and iron oxides which adhere to, or are embedded in, the surface of the stainless steel. These acids cause a removal of the surface layer of between 1 and 3 microns. The article is finally rinsed with water to complete this stage of the process.

Passivation

Passivation of the stainless steel will occur naturally after pickling when the oxygen in the air will react with the surface of the steel to form a passive chromium oxide layer. However it is usual for this passivation process to be speeded up by immersing the article in a nitric acid or other passivating agent.

Pickle and passivation is available as a special order finish, for more information please contact us on +44 (0) 845 605 4333.

Electropolishing

In various industries such as food, pharmaceutical and electronics, there is a requirement for easier cleaning and reduced bacterial growth on the surface of the stainless steel. This increased surface smoothness is achieved by a process called electropolishing.

Electropolishing is, in principle, a reversal of the electroplating process. The article is submerged in a special acid electrolyte and a DC current passed into the article and through the electrolyte. This process removes the high spots from the surface micro roughness leaving a surface which is bright and smooth.

6 Powder coated (E)

Powder coated finishes give excellent protection against scratches as they are normally between 50 - 100% harder than the equivalent wet paint finishes.

They are available in a wide range of colours and can have matt or various gloss finishes. In addition to the aesthetic qualities powder coating are available in various grades to cope with different site conditions. Grades are produced to cope with exterior applications where there can be high levels of ultra violet light or low smoke and fume applications for fire risk areas such as occur in tunnels.

Because powder coated finishes are inherently resilient and resistant to chemical or corrosive attack, these finishes are frequently used for protection only where there is no aesthetic requirement.

Background

The process of powder coating is carried out by applying the electrostatically charged powder to the article, and then passing the article into an oven where the powder is baked onto the surface of the article.

The application of the powder, and the associated stoving, can vary with different types of finish so the careful control of the process is required.

Specification

With such a wide variety of types of powder available it is necessary to specify in addition to the colour what the finish is required to do.

The colour can be specified by BS or RAL number, or by exact colour match if a sample of the colour is provided. The required gloss level should also be given.

The usual finish is for aesthetic indoor use, but if other qualities are required they should be clearly indicated at the outset as the powder cost and application cost can vary considerably between different types of powder.

Epoxy coated

Epoxy coatings are based on thermo-setting epoxy resins and give a very hard, durable finish suitable for internal applications. Epoxy coatings are usually quite thin but they have good chemical resistance with excellent adhesion and coating flexibility.

Polyester epoxy mix

Some modern coating developments consist of both polyester and epoxy. These give properties which are very suitable for use with cable support systems. The finish is thick and fairly soft and gives good protection to the cables being installed. The coating has strong adhesive properties and in cases of fire is halogen free with low smoke and fume characteristics. There are many types and grades of these materials and when using them advice should be sought from our technical sales support team, please contact us on +44 (0) 845 605 4333.

Architectural powder coatings

These powder coatings are formulated to meet the particular requirements of exterior environments. They are inherently resilient and resistant to damage and chemical or corrosive attack, providing maximum protection to the substrate. When subjected to high levels of ultra violet light present within sunlight the coatings have excellent gloss retention and resistance to chalking. These coatings would normally be applied over a galvanised finish.

Installation of services

Cable ladder systems

Cable ladder systems are intended for the support of a combination of cables, electrical equipment and/or communication system installations. Where necessary cable ladder systems may be used for the segregation of cables.

Note : these systems are designed for use as supports for cables and not as enclosures giving full mechanical protection.

These systems are covered by BS EN 61537.

1 Design factors to consider

Consideration should be given to the following factors when undertaking the design of a support system although some of these (e.g. snow/wind loads) may not be relevant to every installation.

- (i) Distributed loads (eg. cables, pipes)
- (ii) Point loads
- (iii) Snow, wind and external forces
- (iv) Safety factor
- (v) Deflection
- (vi) Spacing of supports
- (vii) Location of couplers
- (viii) Installation of cables within a support system
- (ix) Earth protection
- (x) Electromagnetic compatibility (EMC)
- (xi) Thermal expansion and contraction

The following sections provide a wealth of useful information on each of these design aspects.

(i) Distributed loads

Before commencing the design process for a new installation it is usual to consider whether future changes in the pattern of demand for building services will impose increased loading requirements on the support system. If so, it is good design practice to allow both the physical space and sufficient load carrying capacity for the future addition of 25% more cables or other loading medium.

Estimation of cable loads

If full details of the cabling layout are available then the likely cable load can be calculated using either manufacturer's published information or the tables of cable weights and diameters which are given opposite. However, it is often necessary to select a ladder design in the absence of accurate information on the likely cable load. To assist this selection process a useful approach can be to choose a likely size of ladder and then to estimate the maximum cable weight which is capable of being contained within it. This estimate may be arrived at using the following guide :

IN THIS SECTION...

Cable ladder systems

1. Design factors to consider
2. Cable ladder – 6 m lengths over long spans
3. Loading graphs

Max. cabling capacity (kg/m) = cable laying area (m²) x 2800

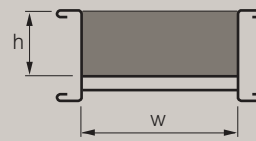

Cable laying area

Cable laying area (m²) = w (m) x h (m)

Applicable to cable ladder

Note : this formula only provides an estimate of the maximum load which can be physically contained within a ladder. The ability of that ladder to support such a load depends upon the spacing of its supports.

Cable weights and diameters

Tables 1 and 2 below give typical weights and diameters (D) for PVC sheathed, steel wire armoured cables with stranded copper conductors.

Tables 3 and 4 give typical weights and diameters for PVC sheathed, unarmoured stranded copper power cables. Cables with XLPE (cross linked polyethylene) insulation are usually slightly lighter so the information given may also be used for these cables too.

For all other types of cable (e.g. paper insulated cable or cable with aluminium conductors) refer to the cable manufacturer's catalogue for details and guidance.

Values show approx weight and diameter of typical cables.
D = Overall cable diameter.

Table 1 : PVC armoured power/control cables to BS 6346

Nom. area of conductor (mm ²)	2 core		3 core		4 core	
	kg/m	D in mm	kg/m	D in mm	kg/m	D in mm
1.5	0.3	12.3	0.3	12.8	0.4	13.5
2.5	0.4	13.6	0.4	14.1	0.5	15.0
4.0	0.5	15.1	0.5	15.8	0.7	17.8
6.0	0.6	16.5	0.7	18.0	0.9	19.2
10.0	0.9	20.1	1.0	21.2	1.2	22.8
16.0	1.0	21.9	1.2	23.1	1.7	26.3

Table 2 : PVC insulated and sheathed circular surface wiring

Nom. area of conductor (mm ²)	2 core		3 core		4 core	
	kg/m	D in mm	kg/m	D in mm	kg/m	D in mm
1.5	0.1	7.7	0.1	8.2	0.1	9.1
2.5	0.1	9.2	0.2	9.7	0.2	10.6
4.0	0.2	10.2	0.3	11.0	0.3	12.6
6.0	0.2	12.0	0.3	12.8	0.4	14.2
10.0	0.4	14.6	0.5	15.6	0.7	17.4
16.0	0.6	16.9	0.7	18.0	0.9	20.0

Table 3 : PVC unarmoured stranded copper power cables to BS 6346

Nom. area of conductor (mm ²)	2 core		3 core		4 core	
	kg/m	D in mm	kg/m	D in mm	kg/m	D in mm
25	0.7	18.4	1.0	20.4	1.3	22.7
35	0.9	20.0	1.3	22.4	1.7	25.0
50	1.2	22.2	1.7	25.4	2.3	28.6
70	1.7	24.6	2.4	28.4	3.1	32.2
95	2.3	28.2	3.3	33.1	4.3	37.2
120	2.8	30.9	4.0	36.0	5.3	40.6
150	3.5	34.1	4.9	39.7	6.5	45.0
185	4.2	37.8	6.1	44.1	8.0	49.8
240	5.5	43.2	8.0	49.6	10.6	56.2
300	7.0	47.2	9.7	55.0	13.2	62.5
400	8.5	53.2	12.6	61.4	16.7	69.6

Table 3 : PVC armoured stranded copper power cables to BS 6346

Nom. area of conductor (mm ²)	2 core		3 core		4 core	
	kg/m	D in mm	kg/m	D in mm	kg/m	D in mm
25	1.3	23.0	1.7	25.1	2.1	27.5
35	1.6	24.8	2.1	27.3	2.6	30.0
50	2.0	27.2	2.6	30.5	3.5	34.8
70	2.5	29.5	3.6	34.8	4.5	38.4
95	3.5	34.4	4.6	39.1	5.9	43.3
120	4.1	37.1	5.5	41.9	7.5	48.1
150	4.9	40.2	7.0	47.2	8.8	52.3
185	6.3	45.1	8.4	51.4	10.7	57.5
240	7.8	50.5	10.7	57.3	13.5	63.9
300	9.3	55.4	12.7	62.6	16.4	69.9
400	11.3	60.8	15.7	68.8	21.3	78.8

(ii) Point loads

Point loads may consist of permanent equipment, such as lighting luminaires, junction boxes or other switchgear, or temporary loads such as commissioning equipment or installation personnel (but see 'Safety during the installation phase' page 141).

Analysis of uniformly distributed loads (such as cables or pipes) is relatively simple but analysing the effect of a point load is quite complex; fortunately a simple alternative approach is available.

Firstly, one makes the reasonable assumption that the point load will be situated in the worst position at mid-span. The force this point load imposes can then be taken as equivalent to that imposed by a load of twice its value uniformly distributed along the span. Thus the point load can be converted to the equivalent uniformly distributed load which is then added to other UDL's to produce one total uniform load.

Example:

Point load = 30 kg

Support spacing = 3 m

UDL = 100 kg/m

UDL equivalent to 30 kg point load =

2 x Point Load = 2 x 30 kg = 60 kg = 20 kg/m

Total UDL = 100 kg/m + 20 kg/m = 120 kg/m

The suitability of a ladder to carry this total load can then be considered using the loading graph information (see p. 131).

Although this treatment does assume the point load will be in the 'worst case' position, the installer should, given discretion, always position any point load as close as possible both to a support and to either side flange, minimising the stress on the installation, as per the following illustration.

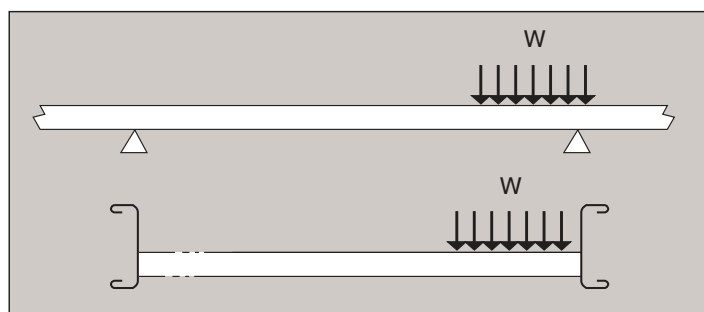

Single spans

For single spans the loading capability is also severely reduced. In this circumstance the safe working load (SWL) should, as a simple rule, be reduced to half that indicated by the loading graphs on p. 131, and there must be no joint in the span.

This derating of the loading capacity for either single spans or point loads depends to some extent upon the ladder type and the intended span. If therefore the design calculations indicate this aspect is critical, more detailed information should be sought from Legrand, contact us on +44 (0) 845 605 4333.

(iii) Snow, wind and external forces

The loading graphs on p. 131 show the maximum safe working steady load for each type of support system. If the system is outdoors and must also sustain snow, ice, wind or other variable forces these must also be taken into account at the design stage.

Appropriate design data for UK weather conditions is given in British Standard BS EN 1991, see p. 142.

For snow and ice the appropriate extra weight as indicated by these standards must be added to the weight of the cable (and any point loads) to give a total working load; this should then be compared with the safe working load (SWL) for the ladder using the graphs in this document.

The horizontal force imposed by a wind is proportional to the vertical surface area of the installation so particular care must be taken where cable ladder will be mounted on edge. Where high winds are likely, large spans should be avoided.

High winds can also create a strong lifting force on ladder or covers and this too must be borne in mind when installing covers in exposed locations. Ideally covers should not be installed temporarily, they should only be installed after the electrical installation has been completed and they must be properly secured immediately.

(iv) Safety factor

To arrive at a safe working load (SWL) for each type of equipment Legrand test their products to find the ultimate failure load. The SWL is obtained by dividing the load before failure by a factor of 1.7 minimum.

This safety factor may need to be increased by the designer depending upon the circumstances. For example, if the support system is expected to be subject to aggressive abuse a safety factor as high as three or more may be used. Such treatment is, however, the exception and care should be taken not to over-design the system by using an unnecessarily high safety factor.

(v) Deflection

The deflection of a cable ladder under load is not directly related to its strength but it is obviously of aesthetic importance. For this reason it may be necessary to estimate the likely deflection whilst designing an installation, especially if it will be in a highly visible location. Experience has shown that in order to maintain a degree of deflection which is subjectively acceptable to the eye, the load on the cable ladder will often be restricted to well below its safe maximum.

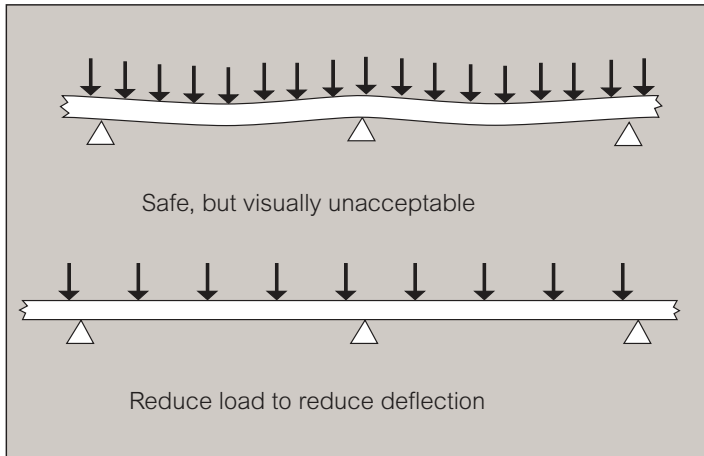

(vi) Spacing of supports

Services support installations are usually considered as multi-span arrangements but it is important to recognise that the loading capability of the system is not uniform from end-to-end. The strength of the two end spans in any run is much lower than that of intermediate spans, even when the ends are rigidly fixed. In many situations the end spans will be more lightly loaded anyway; if however they are not and the installation will be fully loaded from end-to-end then it is recommended that the support spacing of both end spans should be reduced to no more than three quarters that of intermediate spans. However it is not a mandatory requirement, but is both useful and advisable.

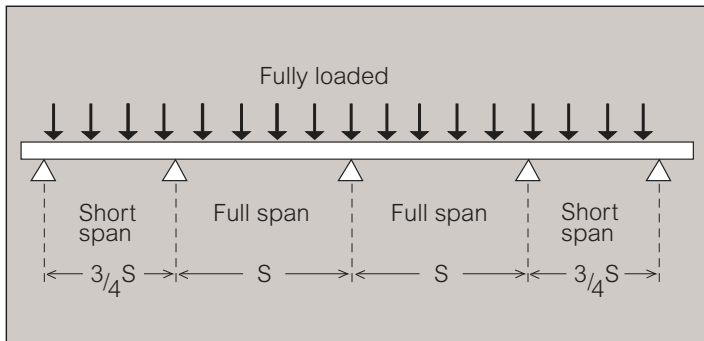

Sometimes the necessary support spacing may be dictated by the nature of the building fabric. If however the designer has discretion over the spacing of supports the loading graphs can be used to maximise this distance. This will reduce the number of support components and fixings that will be required, thus reducing the overall cost of the installed system.

Supports for cable ladder

Cable ladder installations are usually designed with a significantly longer spacing between supports, 2 to 4 metres being a typical span distance.

Support of fittings

Cable ladder fittings must always be provided with local support. The illustrations on pages 125 to 126 give recommended support positions.

(vii) Location of couplers

In practice it is often impossible to pre-determine where the couplers will be located within a straight run of cable ladder. However it is well worth making some effort to roughly plan their position during the early stages of installation.

The worst positions for the couplers is at mid-span. At these locations they will suffer the greatest stress. A mid-span joint should be particularly avoided on the end spans of an installation to minimise deflections.

The best position for joints in a continuous installation is on quarter of the span distance on either side of each point of support.

However, for 6 m spans using 6 m ladders the best position for the joints is on the supports (refer to section 2 on page 128).

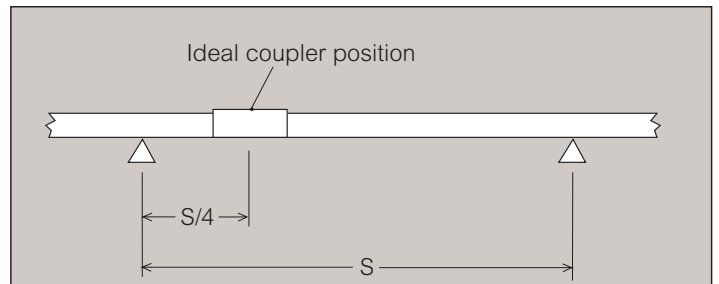

Loading graphs

Refer to loading graphs on page 131.

Recommended support locations – cable ladder

Large = ladder widths or radius 600 mm and above
 Small = sizes below 600 mm

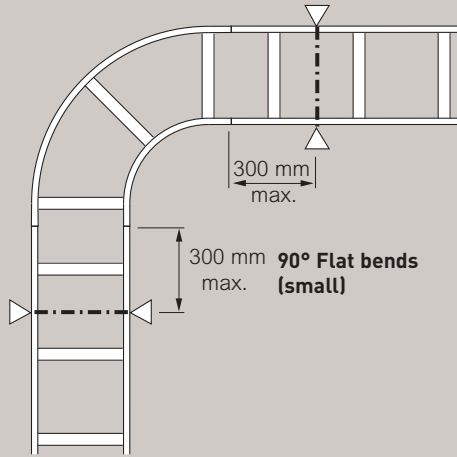

90° Flat bends (small)

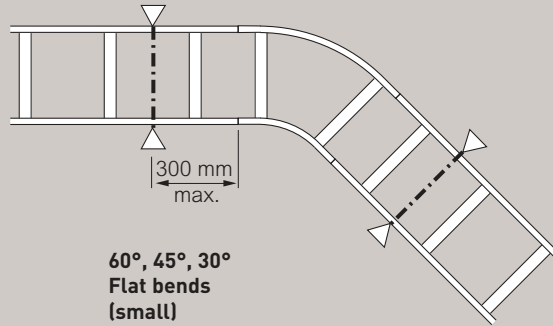

60°, 45°, 30° Flat bends (small)

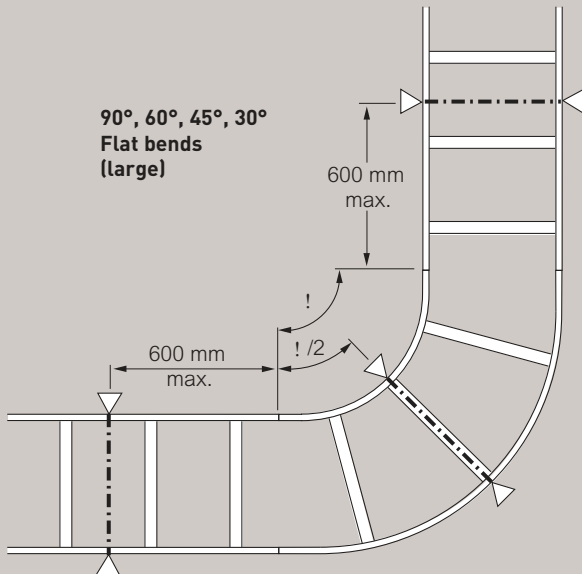
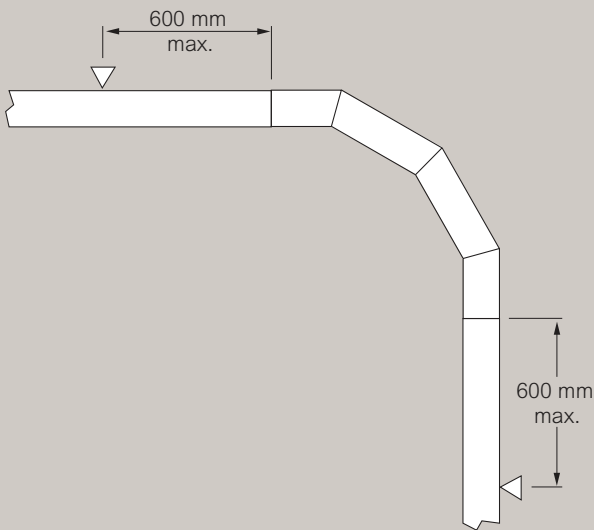

90°, 60°, 45°, 30° Flat bends (large)

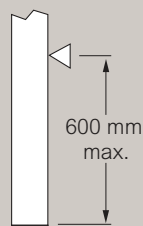

90°, 60°, 45°, 30° Inside and outside risers

NOTE :

For inclined ladder runs, support spacing should not exceed those recommended for horizontal runs.

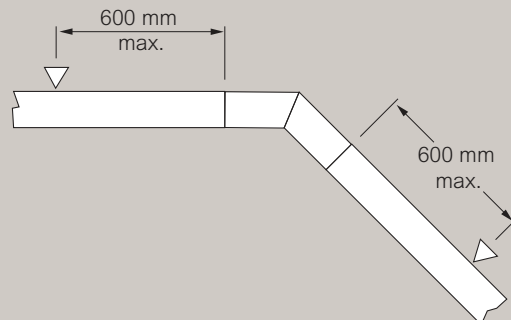

Recommended support locations – cable ladder (continued)

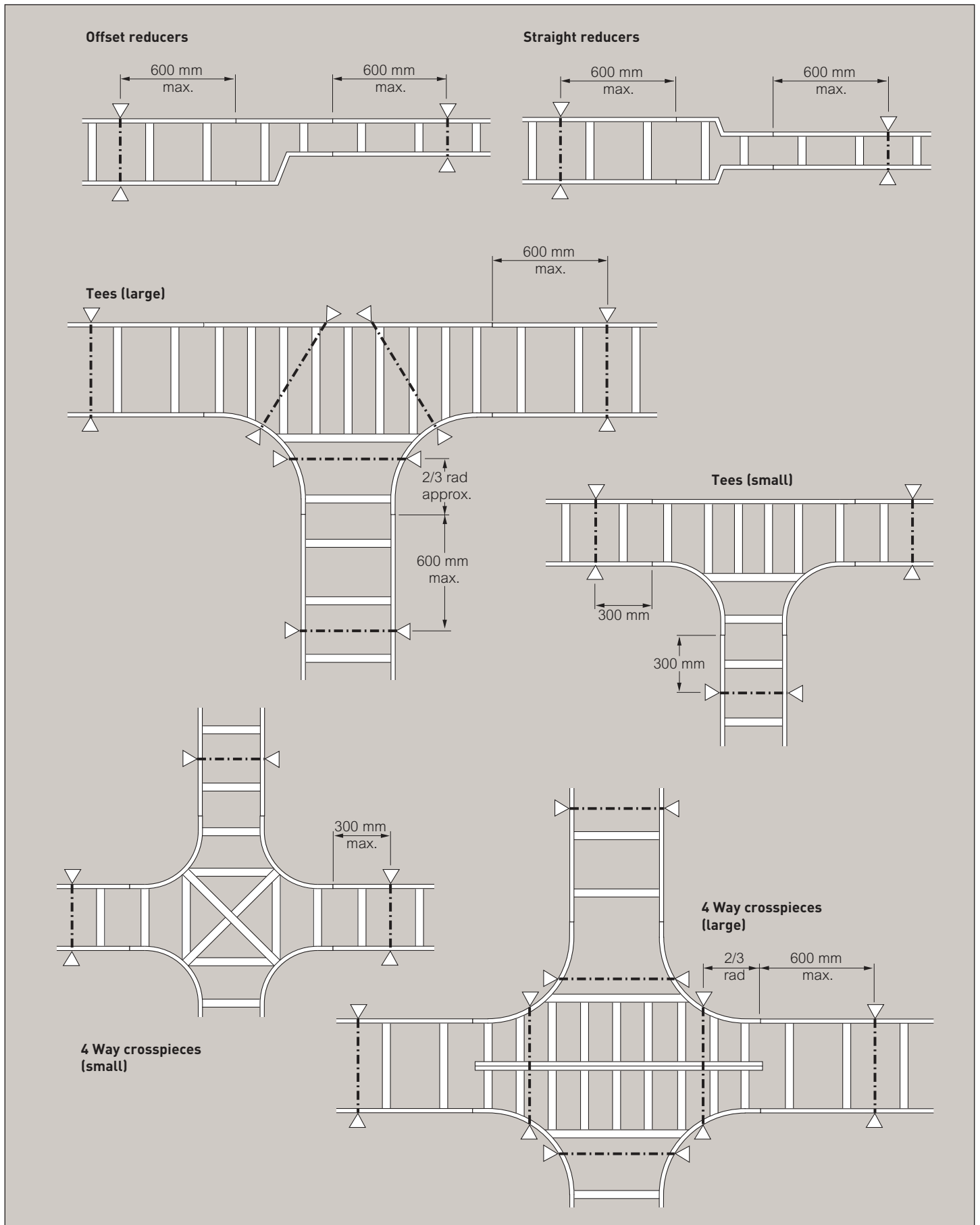

(viii) Installation of cables within a support system

Detailed guidance concerning the selection and use of appropriate electric cables is available from cable manufacturers, relevant standards (both British Standards and European Cenelec Standards) and the Wiring Regulations. However the following general comments may also be helpful.

Cables are designed for continuous operation within a range of ambient temperatures; attention must be paid to the ventilation arrangements to ensure that the maximum temperature is not consistently exceeded. Where cable routings pass through enclosed ducts it is important to ensure that the ducts are large enough to avoid overheating.

Cable support spacing

Cables must either be continuously supported or supported at intervals which are no more than those given in Table 5 below. Cables should not themselves be used as a support or as a restraint for other loads.

Table 5

Cable diameter (mm)	Support spacing (mm)	
	Horizontal ⁽¹⁾	Vertical ⁽²⁾
Below 100	250	400
10 to 15	300	400
16 to 20	350	450
21 to 40	400	550

(1) From horizontal through to 60° inclination

(2) From 60° inclination (30° from vertical) through to vertical

Fixing of cables to cable ladder

In addition to cable ties or strapping, steel, aluminium or moulded cleats are also frequently used; alternative rung slot patterns are available to suit the various fixing options.

Minimum bending radius of cables

All cables have a minimum bending radius beyond which they should not be bent either during handling or when finally installed. Details of the minimum bending radius for various types of cable are given in Table 6 below.

Table 6

Type of cable (mm)	Minimum bending radius D = cable diameter
Unarmoured cable, D < 10 mm	3D
Unarmoured cable, 25 mm < D < 10 mm	4D
Unarmoured cable, D < 25 mm	6D
Armoured cable to BS 5467, BS 6346 and BS 6724 (LSF cables)	8D

Radius of fittings

On a cable support system the size and type of cables must be considered to ensure that the radius of the support fittings exceeds the minimum bending radius of the cables themselves. The table above gives a general guide to these minimum values but wherever possible a larger installation radius should be used. Cables must not be accidentally bent to a tighter radius during installation. If only one or two large cables are being installed on a flat ladder installation (without risers) then it may be possible to use smaller radius fittings by ensuring these cables are always positioned along the centre of the ladder.

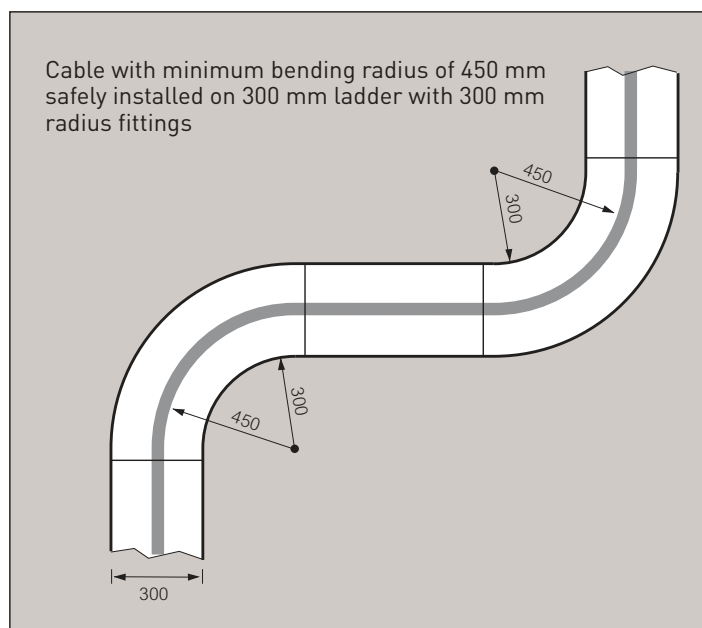

(ix) Earth protection

Cable ladder is deemed to provide continuous support to any cables installed upon it but, because it is not completely enclosed, it does not offer mechanical protection. For this reason unshielded, single insulated power cables should not be installed on ladder, all cables should have some mechanical protection in the form of PVC sheathing, steel wire armouring or a copper covering (MICC). Where moisture may be present, copper covered cables must also be PVC sheathed to avoid electrochemical corrosion between the copper and the cable support system.

Cable ladder can be specifically designed to act as a circuit protective conductor (CPC), which connects exposed conductive parts of equipment to the main earth terminal and will thereby provide some protection against electric shock. For this to be acceptable the cross-sectional area of the cable support must exceed a value obtained by calculation, the formula for this calculation being given in Regulation 543-01-03 of the Wiring Regulations BS 7671. This formula takes into account the fault current of the circuit, the nature of the cables themselves and the operating time of the disconnecting device used to protect against excessive currents. Other features, such as protection of the support system against mechanical damage and corrosion (to ensure the CPC remains intact), visual identification that the support system is being used as a CPC and the impedance of the circuit must also be considered by a competent electrical engineer before ladder can be used as a CPC.

If armoured cables (with an integral CPC) are installed on a ladder and the support system is not being used as a protective conductor, then it is generally considered as a metal part which is neither extraneous nor exposed; continuity is not an issue in this situation. Normal ladder assembly methods are adequate and BS 7671 (the Wiring Regulations) impose no requirement for continuity of such metal parts unless they are being used as a protective conductor.

If unarmoured cables are installed on a ladder installation which is not being used as a protective conductor, consideration should be given to the possibility of damage to these cables, causing the ladder to become live and hence the need to earth the support system.

The continuity of properly fixed ladder joints is such that earth continuity connectors (bonding connectors) are not necessary for any general ladder application; however in special locations or hazardous areas (as described in BS 7671: Section 6) earth continuity connectors may be required, subject to consideration by a competent electrical engineer.

(x) Electromagnetic Compatibility (EMC)

In normal use cable ladder is considered as passive in respect of electromagnetic influences. The installation of current carrying media may cause emissions and these media may also be influenced by electromagnetic signals from elsewhere but the degree of influence will depend on the nature of the installation and the apparatus connected to the system.

A draft technical report IEC1000-S-1 provides details of the cable separation required according to the type of signal being considered and the IEE Guidance Note No.1 provides further information on the subject of EMC. However, as a basic principle, if power and signal cables can be run separately on different ladders then this will significantly reduce any possibility of one electrical circuit having any undesirable influence upon another.

(xi) Thermal expansion and contraction

In locations where large variations in temperature are anticipated the design of the support system should make allowance for changes in the length of the support system due to the expansion and the contraction of the metal.

For cable ladder, Swifts flexible couplers provide for 10 mm of linear movement between adjacent ladders. They should be installed instead of standard couplers at regular intervals with their spacing being determined using the following formula :

$$L = \frac{K_s}{T}$$

where:

L = Distance between flexible couplers, in metres

K_s = 909 for mild steel or 962 for stainless steel

T = Range of temperature variation (in Celcius degrees) for which allowance is to be made

For information, the relevant coefficients of linear expansion are :

Mild steel $11 \times 10^{-6} / ^\circ\text{C}$

Stainless steel $10.4 \times 10^{-6} / ^\circ\text{C}$

When expansion couplers are used, the ladder must be supported either side of the joint.

2 Cable ladder – 6 m lengths over long spans

The maximum acceptable deflection for cable ladder is normally considered to be 1/200th of the span distance. However, when cable ladder is to be installed on long spans of 5 m or 6 m the limiting factor which determines the loading capacity is the maximum allowable stress in the ladder side rails rather than the deflection. Deeper side rails can withstand higher stresses and for this reason 125 mm deep Sapphire or 150 mm deep Emerald ladder should be used for long spans. The use of 3 m ladder lengths is not recommended for long spans.

The end span of any installation cannot safely support the same maximum load as the inner spans. If therefore the applied cable load is uniform from one end of a run to the other then it is advisable to incorporate at the design stage some reduction in the length of the two end spans. If using 6 m ladders over 6 m spans, with joints on supports, then end span reduction will require cut lengths.

The designer should also endeavour to provide supports which are wider than normal, 80-100 mm is ideal on a long span installation. This reduces the local stresses at the contact footprint where the full weight of the installation is carried by the bottom flange of the ladder. On most ladder installations it is good practice to locate the couplers within the span where the bending moments are lowest. However on 6 m spans the couplers should be located directly over the points of support as this will also provide additional local reinforcement of the ladder side rails.

For external installations a maximum ladder width of 600 mm is recommended in order to reduce the possible effect of wind and snow, these being exaggerated on longer spans. On cable ladder installed internally these unpredictable loads are less of a problem. Nevertheless, they cannot be totally disregarded as the careless application of temporary loads to one side rail of a fully loaded system (e.g. a carelessly placed access ladder) can be potentially damaging.

Care is also needed with regard to any dynamic loads which may cause oscillations in long ladder spans; this is much less likely after the cables have been installed as their stiffness (especially with larger cables) will heavily dampen the system and reduce any tendency for oscillations to develop.

The effect of lateral loads can be much reduced by adding diagonal bracing to the cable ladder (see illustration). See p. 37 for further details.

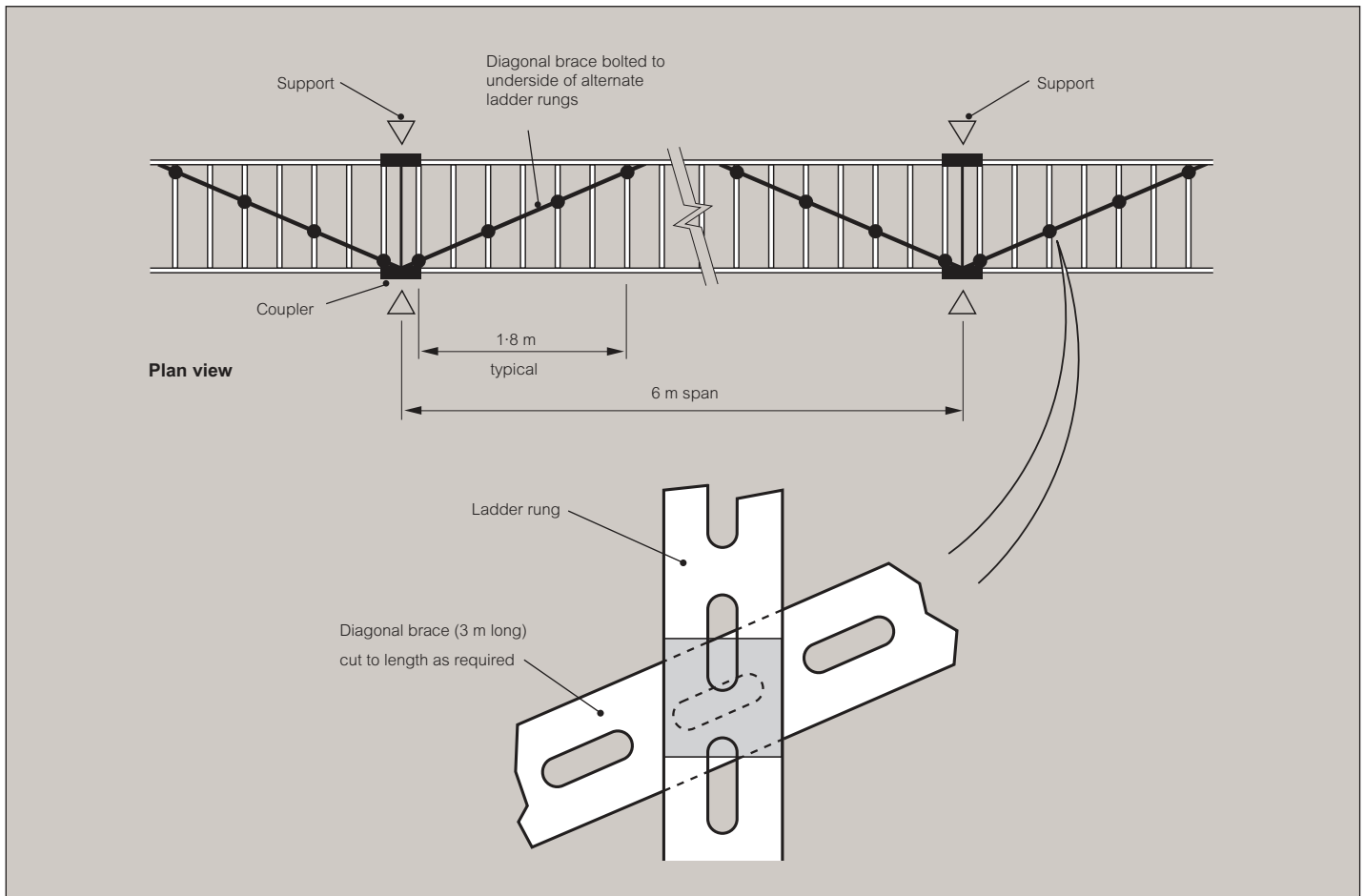

The loading proposed for any cable support system must be carefully checked against the information provided to ensure the integrity of the complete installation. The suitability of the support brackets, their spacing and their strength should be checked using the information given in this document. The method used to fix the support system back to the structure is equally important and must be checked for structural safety.

These loading graphs are based on cable support systems which run across multiple spans with the imposed load uniformly distributed. The user should ensure that allowance is made for any snow, wind or other external loads within these total loadings. Appropriate design data for these is provided by British Standard BS EN 1991, see p. 142.

3 Use of loading graphs

Provided the relevant graph line lies above the intersection of the load/span lines the proposed arrangement is acceptable. (See the illustration opposite). The deflection will often be less than 1/200th of the span and in most cases it will be less than 1/360th of the span. However where point loads will be imposed or where there are short runs with three spans or less, the deflection will increase and the safe working loads (SWL) may need to be reduced from the values given.

Further information on this subject is given on pages 122 to 124.

These graphs should not be extrapolated to longer spans than shown, nor should they be used for situations where the bed of the ladder is vertically orientated. In exposed situations the use of long spans requires particularly careful consideration, see page 128. Any further information on loads and deflections for such circumstances should be sought from Legrand, contact us on +44 (0) 845 605 4333.

The values given in this document have been obtained from extensive testing of our cable support equipment. They are given as a guide, so that their customers may use Legrand's products to the best advantage; they are nevertheless average figures which are given in good faith, but without accepting any liability in contract, tort or otherwise in the event of different performance by equipment which is actually supplied.

The cable support systems in this document are not designed for use as walkways or to support personnel during cable installation.

Loading graphs

The loads shown on all graphs are the safe recommended maximum loads that can be applied and must include wind, snow and any other external forces in addition to the cable load. The graphs show the maximum load for ladder installed at a support spacing within its recommended range.

When the graph line is above the intersection of the required load and span lines, the support equipment is suitable for use within those load and span conditions.

The graphs shown are for hot dip galvanised finish, with an indication of stainless steel where applicable.

Load tests carried out to BS EN 61537 test type 1 (safety factor 1.7+ and joint in middle of span) or test type 4 (safety factor 1.7+ and joint in middle of span with rung slot over support).

Load tests for medium duty (Topaz) carried out over 2 m, 3 m and 4 m spans using 3 m lengths.

For heavy duty (Sapphire) and extra heavy duty (Emerald) cable ladder, load tests carried out over 3 m, 4 m, and 5 m spans using 3 m lengths and 6 m spans using 6 m lengths.

For spans 5 m and less : data can be used for 3 m or 6 m lengths

For spans greater than 5 m : data is for 6 m lengths only.

For spans greater than 5 m : ladder is not suitable for use with dynamic loads (e.g. wind, snow).

When installed, inner span deflection will vary depending on joint positions but will typically be about half of test end span deflection shown on following page.

Medium duty (Topaz)

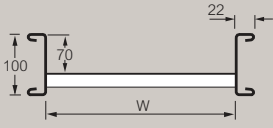

End span deflection at Max. SWL (mm)

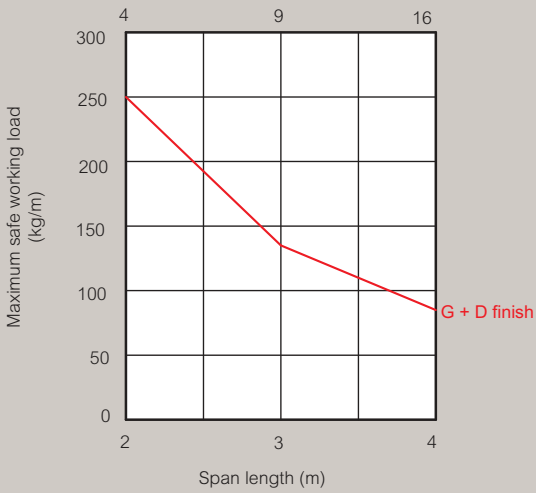

Graph showing safe working load vs span with deflections shown at SWL

Heavy duty (Sapphire)

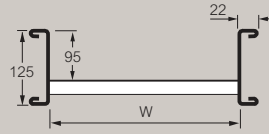

End span deflection at Max. SWL (mm)⁽¹⁾

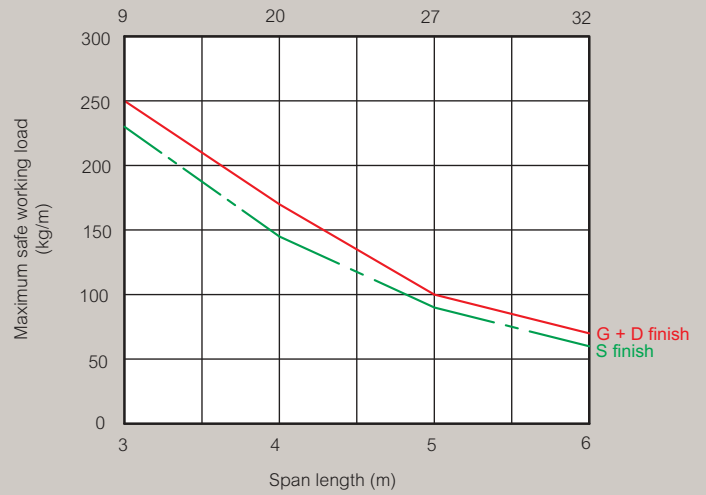

Graph showing safe working load vs span with deflections shown at SWL

(1) Deflections shown for G finish. D and S finish deflections on application, please contact us on +44 (0) 845 605 4333

Extra heavy duty (Emerald)

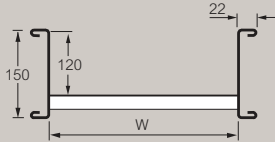

End span deflection at Max. SWL (mm)⁽¹⁾

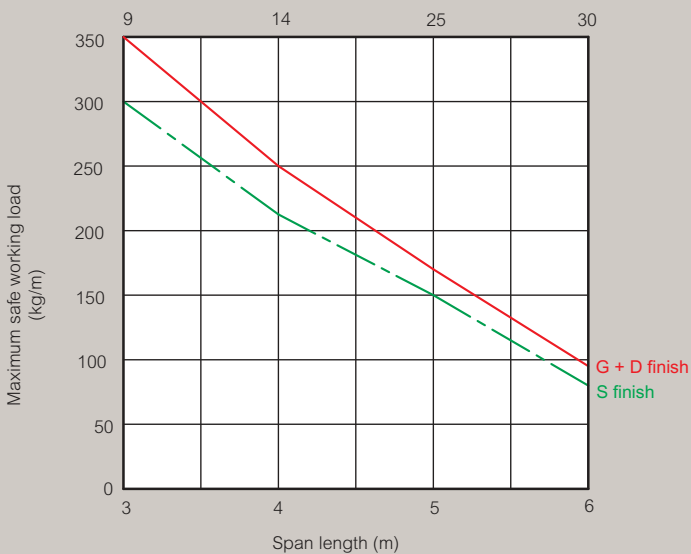

Graph showing safe working load vs span with deflections shown at SWL

(1) Deflections shown for G finish. D and S finish deflections on application, please contact us on +44 (0) 845 605 4333

Example

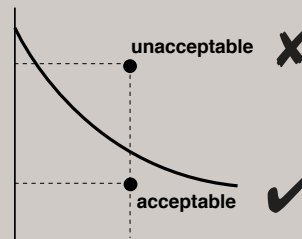

Structural support characteristics

including channel support systems

IN THIS SECTION...

Structural characteristics

1. Cable ladder
2. Beams
3. Columns
4. Deflection

Designing support systems

1. Ceiling to floor applications
2. Ceiling mounted applications
3. Wall mounted applications
4. Floor mounted applications

Swiftrack channel support

1. Channels
2. Channel nuts
3. Framework brackets
4. Fasteners
5. Cantilever arms
6. Maximum safe recommended loadings
7. Channels used as beams
8. Channels used as columns
9. Fully restrained and unrestrained loads
10. Beam loads

Structural characteristics

1 Cable ladder

On many occasions cable ladder is installed in circumstances where it will only ever carry a light cable load, possibly just one or two cables, and its main role is to physically secure and protect its contents. In these situations it is often the inherent ruggedness or the aesthetics of the ladder design which bear most heavily on the specification decision. However, when a support system is required to be more heavily loaded it is useful to have a knowledge of the theoretical aspects of rudimentary structural design in order to ensure that the completed system does fulfil its purpose with the greatest safety and economy.

2 Beams

Any installed ladder system can be considered structurally as a loaded beam; four basic beam configurations may be found in a typical installation :

- Simple beam
- Fixed beam
- Continuous beam
- Cantilever beam

Simple beam

A single length of cable ladder mounted on, but not fastened to, two supports represents a simple beam, which will bend as any load is applied to it with the supports offering no restraint to this bending.

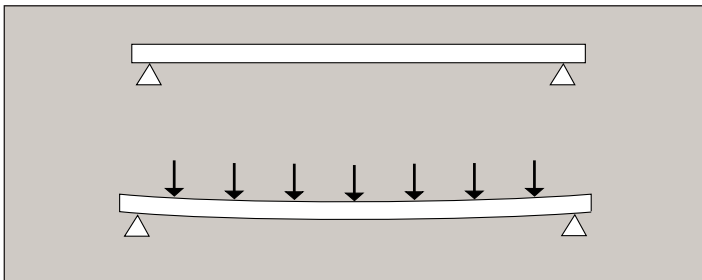

This simple arrangement is fairly onerous and does not realistically model many real-life installations; thus the load/deflection information given in this document is based upon more typical multi-span configurations, which incorporate joints too. However, if an unjointed single span does actually occur the safe working load (SWL) can, as a practical guide, be taken as 1/2 of that indicated by the loading graphs.

Fixed beam

A fixed beam arrangement is a single structural member with both ends fastened rigidly to supports. Compared with a simple beam this degree of restraint does significantly increase the ability of the beam to carry loads but it is unlikely that cable ladder can, in practice, be secured sufficiently rigidly to be considered as a fixed beam.

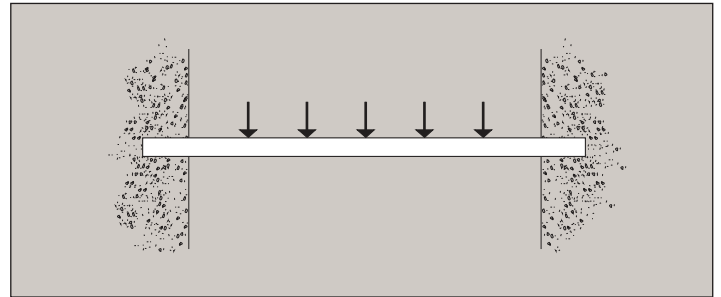

However, in the context of a complete ladder system the main importance of the fixed beam configuration is that some appreciation of its properties, along with those of a simple beam arrangement, will assist the designer to understand the more complex behaviour of a continuous, multi-span cable ladder installation.

Continuous beam

A typical multi-span ladder installation behaves largely as a continuous beam and the greater the number of spans the closer the similarity. However in practice a run must contain joints and it can also never be considered of infinite length so it is important to appreciate how its characteristics do vary from span to span and how these variations should be taken into account when designing the installation.

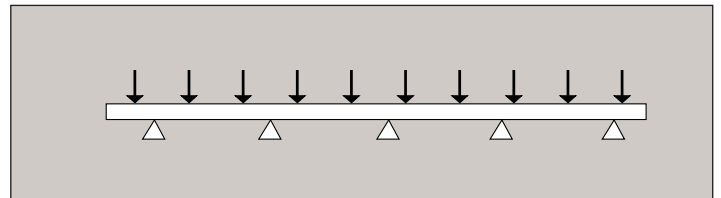

When a run of cable ladder is loaded uniformly from end to end the load on each span is effectively in balance with the loads on the adjacent spans.

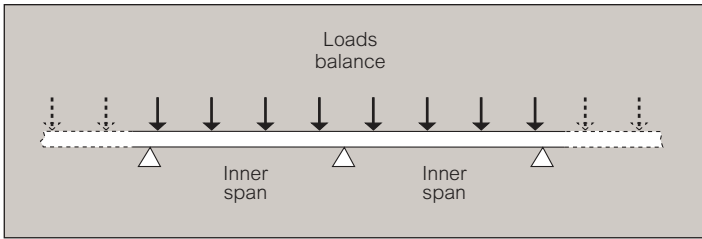

This causes the inner spans to behave substantially as fixed beams imparting to them a considerable load carrying ability. However the two end spans of the installation are not so counterbalanced thus they perform more akin to simple beams, with consequently lower load carrying capabilities.

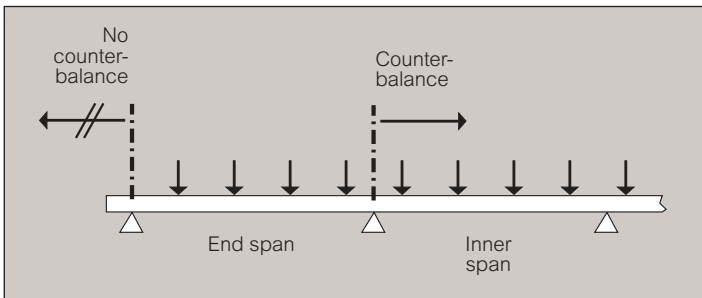

However if this is not the case the support spacing on the two end spans should advisably be reduced to $3/4$ of the intermediate spans in order to compensate (see page 124, spacing of supports).

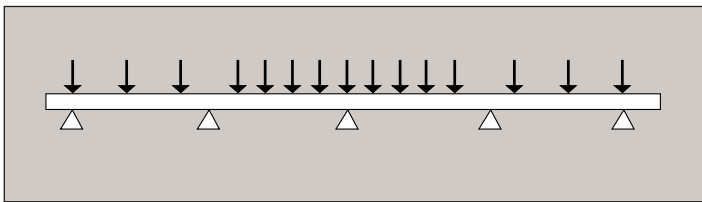

Cantilever beam

This type of arrangement most commonly occurs with the brackets which are used to support cable ladder, these being fixed to the structure at one end only.

For cable ladder installations it is usual to consider the cable load to be uniformly distributed along the length of the cantilever arm (i.e. across the width of the ladder); however, if cables will be bunched then their combined weight effectively acts as a point load on the arm so the bunch should, ideally, be laid nearest the supported inner end.

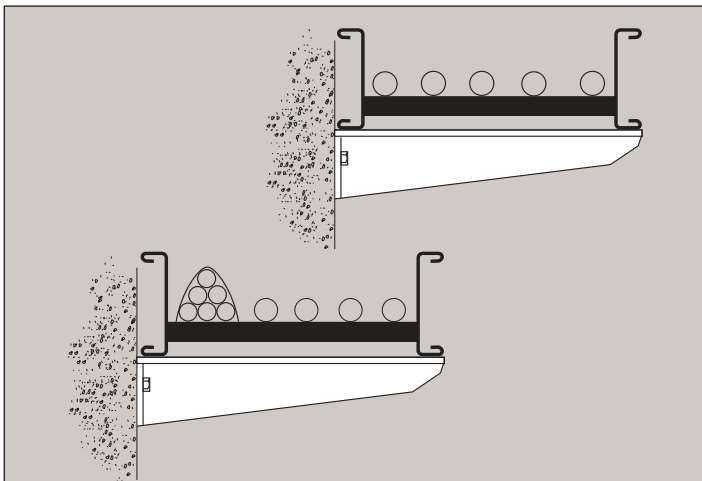

3 Columns

Any vertically arranged component, whether ladder or channel, acts structurally as a column; however it is not usual to consider ladder in this way because it is not designed for this purpose.

Swiftrack channel sections, in both single and multiple configurations, are however frequently arranged as vertical columns and the properties of these sections are both consistent and well known, making them suitable for an analytical approach to be used.

The downward load which can be applied to the end of a column is proportional to the compressive strength of the material from which it is made, but will reduce as the column gets longer. However there are few real applications where no loads are applied from other directions and since the effects of such loads are very significant it is important to consider the totality of the intended structure rather than focus simplistically only on the loads applied down the column.

Proper structural analysis must take detailed account of any side forces or eccentric loads caused by cantilever arms or other brackets fixed to the vertical channel. Such calculations must be carried out by a qualified engineer. The necessary data on the structural properties of the various channel sections is given on page 134, 'Designing support systems'.

4 Deflection

As discussed earlier (page 123, Deflection), the deflection of a ladder under load is not directly related to its strength. However deflection is directly proportional to the applied load, so doubling the load will double the consequent deflection.

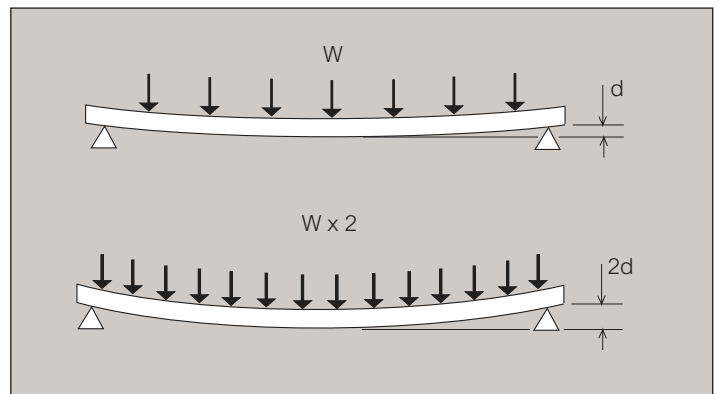

Any point load will have a magnified effect upon deflection. For a point load placed at mid-span (the worst position) the deflection will be approximately double that caused by the same load uniformly distributed along the span, although this value will vary depending upon the coupler and support positions.

Designing support systems

Swiftrack channel support system includes a range of versatile components which link together to provide support for any building services, including tray, ladder, trunking, piping, sprinkler systems and heat/ventilation ducting. Assembled on site, without welding, Swiftrack can be broken down into various elements. Each element needs to be checked to ensure the following :

- It can safely support the loads being imposed upon it (see p. 138-139)
 - The proposed fixing to adjacent elements can also support the required loads (see p. 138)
- Conforms to BS 6946

1 Ceiling to floor applications

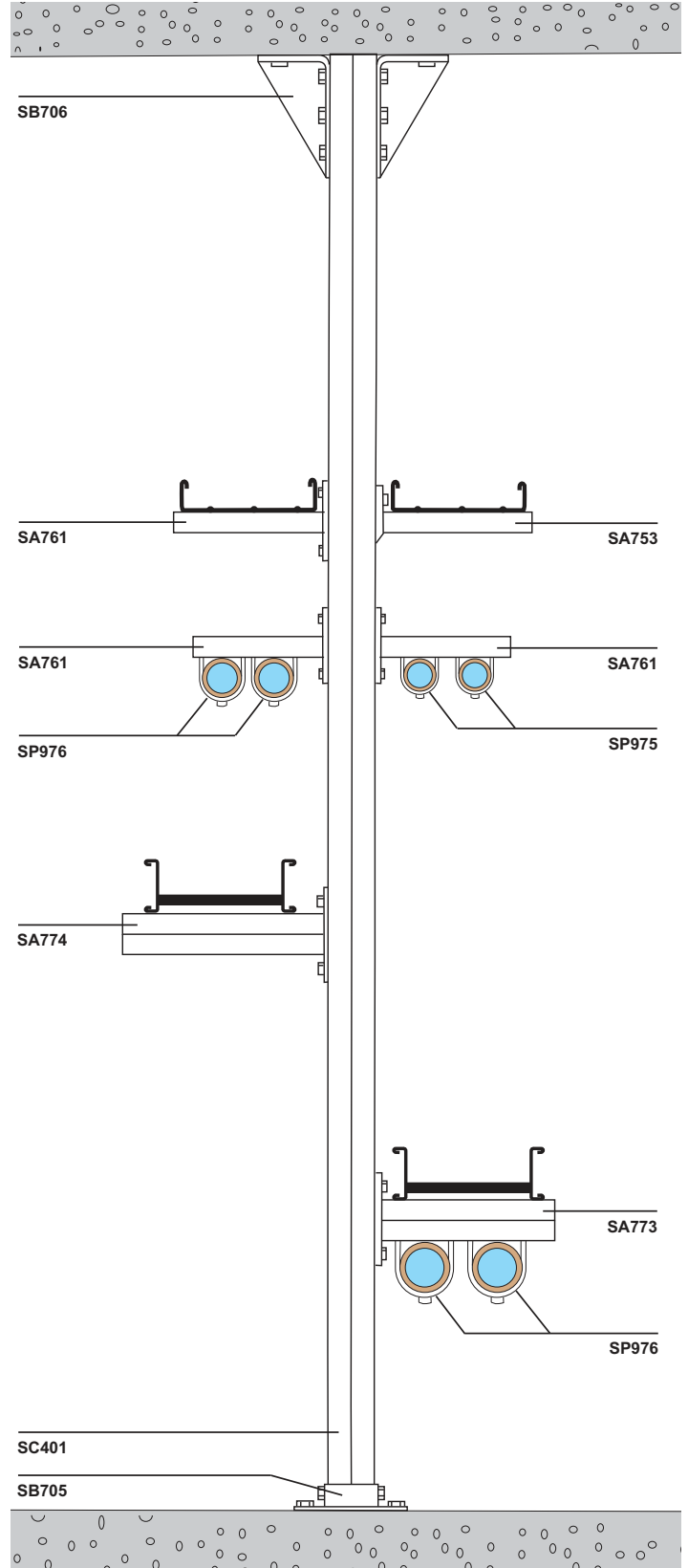
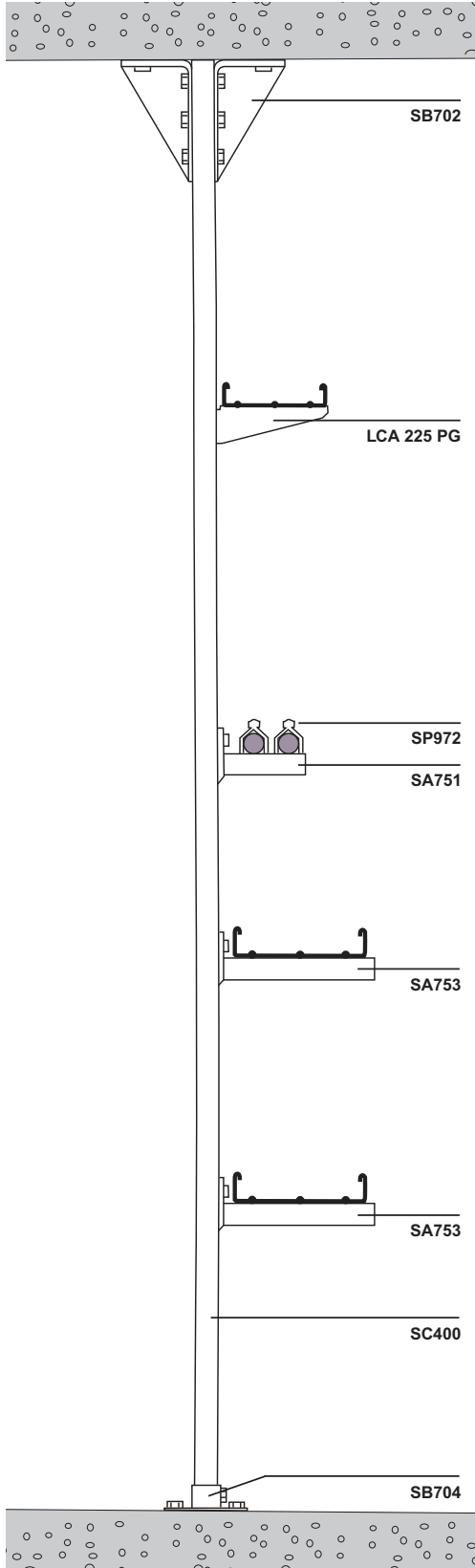

2 Ceiling mounted applications

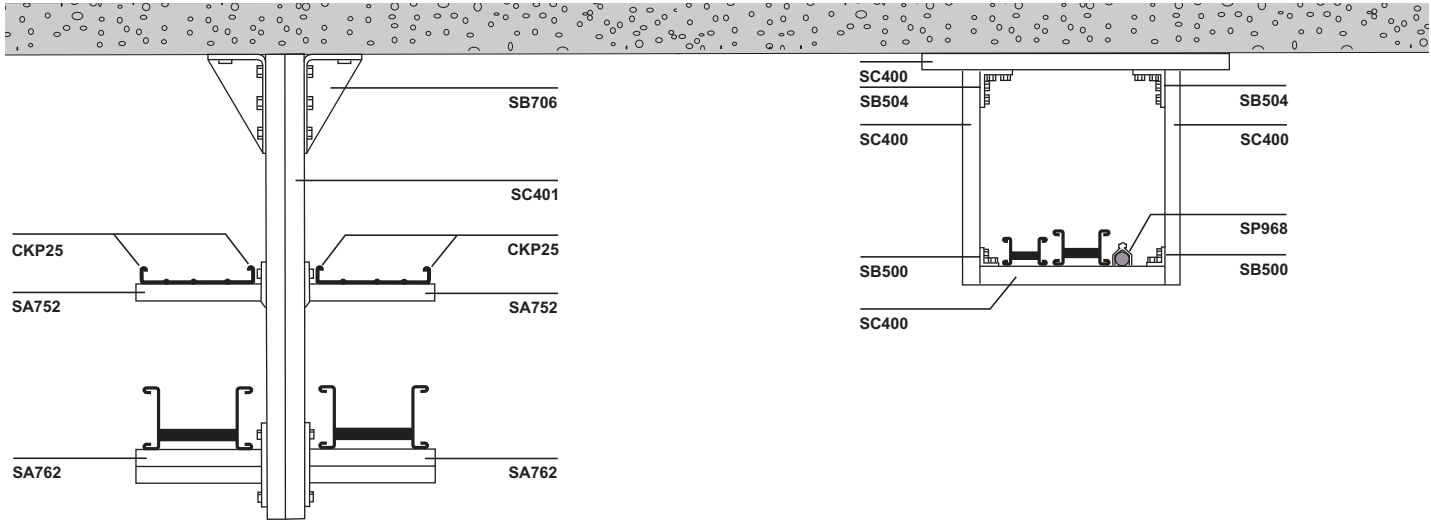

3 Wall mounted applications

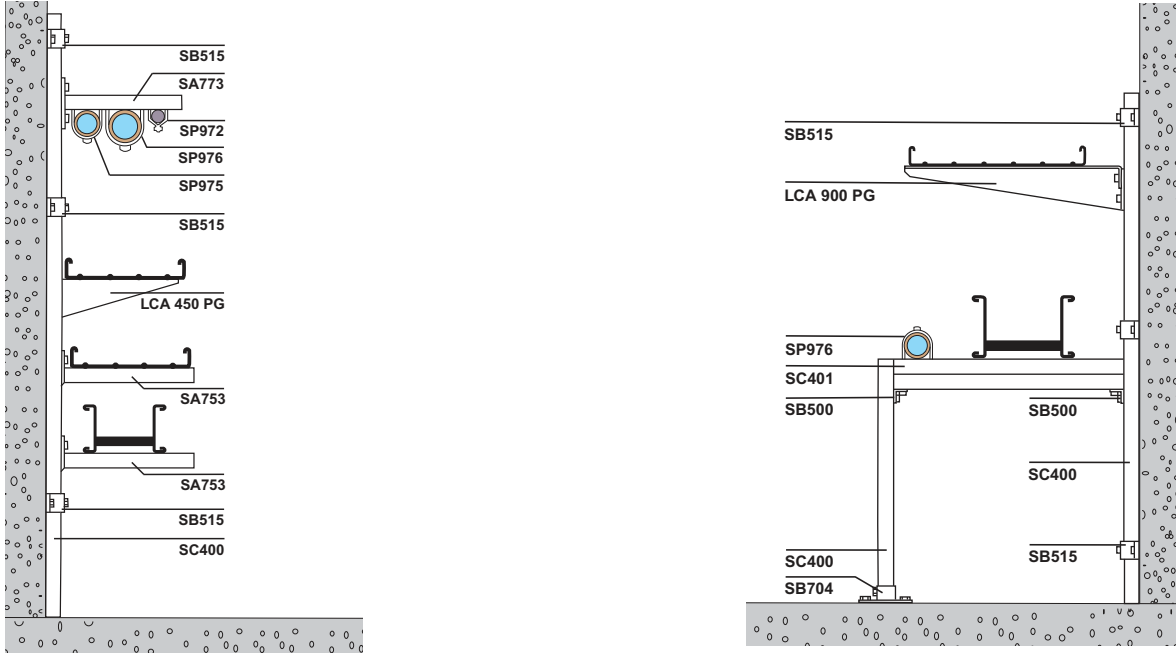

4 Floor mounted applications

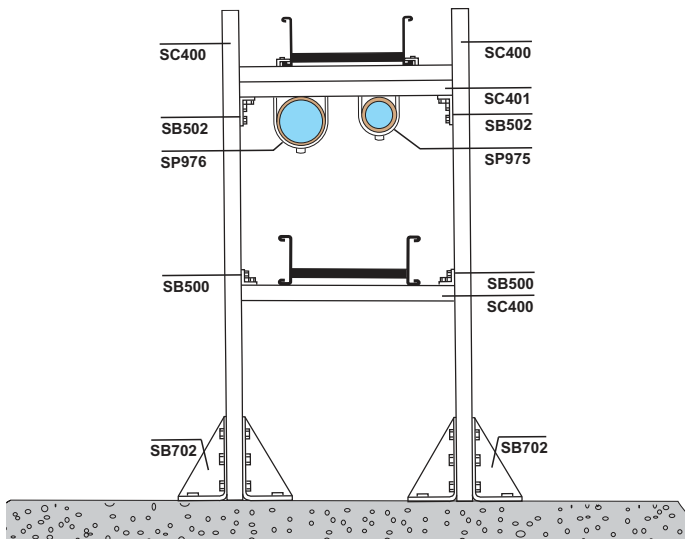

Swiftrack channel support

1 Channels

Standard channels are cold rolled to BS 6946 from 2.5 mm pre-galvanised mild steel to BS EN 10346 : 2009 grade S250GD + Z275

Light gauge channels are cold rolled from 1.5 mm pre-galvanised mild steel to BS EN 10346 : 2009 grade S250GD + Z275

Back-to-back channels are formed by spot welding together two finished single channels at 150 mm centres under controlled conditions to BS EN 1993-1-3 : 2006. All welds and spot welds are suitably protected

The standard lengths for single or multiple channels are 3 m and 6 m

Minimum yield strength, Y_s : 250N/mm²

Minimum ultimate strength : 350N/mm²

Minimum design strength, P_y : 250N/mm²

Section properties

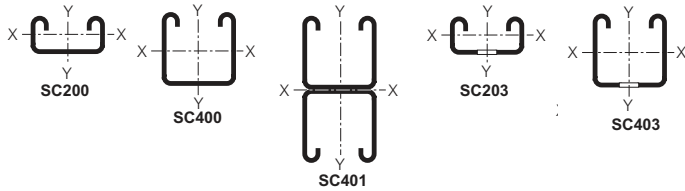

Cat. Nos.	Wt kg/m	A mm ²	I ^{xx} mm ⁴	Z ^{top} (min) mm ³	Z ^{bottom} (max) mm ³	r ^{xx} mm	I ^{yy} mm ⁴	r ^{yy} mm
SC200	1.8	219	10779	862	1330	7.1	49776	15.1
SC203	1.6	219	8960	794	961	6.4	49318	15.0
SC400	2.6	322	67157	2857	3772	14.5	88783	16.6
SC401	5.3	645	339300	8215	8215	23.0	177566	16.6
SC403	2.4	322	57221	2645	2909	13.3	88325	16.5

Wt = weight of section (kg/m)

A = cross-sectional area (mm²)

I^{xx} = moment of inertia = second moment of area (mm⁴)

Z^{top} = section modulus about xx axis (mm³)

Z^{bottom} = section modulus about xx axis (mm³)

r^{xx} = radius of gyration (mm)

I^{yy} = moment of inertia = second moment of area (mm⁴)

r^{yy} = radius of gyration (mm)

xx = about xx axis

yy = about yy axis

2 Channel nuts

The safe working loads for zinc plated channel nuts only.

Slip M10 : 3.0kN

M12 : 3.5kN

Pullout M10 : 6.0kN

M12 : 8.0kN

Safety Factor 3 when tested to BS 6946

Torque tightened to : M10 : 5.5 kgf.m (40 ftlb)

M12 : 7 kgf.m (50 ftlb)

3 Framework brackets

Brackets are manufactured to BS 6946.

Unless otherwise stated, brackets are made from 5 or 6 mm thick steel to BS EN 10025 Grade S275JRC.

Material Properties

Minimum yield strength : 275 N/mm²

Maximum Loads

Maximum loads for individual brackets are given with the illustrations on pages 104 to 107. In most cases the mode of failure will be slippage of the bracket along the channel. However there are few channel/bracket combinations where the maximum load is dependent upon the strength of the bracket itself. Only M10 or M12 channel nuts and bolts should be used for the attachment of load-bearing brackets.

4 Fasteners

Fixing brackets and supports to Swiftrack channel

Standard fasteners for Swiftrack are high tensile hexagon head setscrews to BS 3692-8.8, these being zinc plated to BS 3382 : Part 2.

Channel type	Fitting thickness	Recommended fastener ⁽¹⁾
Deep channel SC400 series	6 mm and 8 mm 5 mm and 6 mm	M10 or M12 x 35 mm ⁽²⁾ M10 or M12 x 20 mm
Shallow channel SC200 series	7 mm and 8 mm 5 mm and 6 mm	M10 or M12 x 25 mm ⁽²⁾ M10 or M12 x 20 mm

(1) The use of too long a fastener will prevent proper tightening because the bolt end will foul the bottom of the channel before the head tightens down on the fitting

(2) When fastener brackets other than Swiftrack, longer bolts may be required if the bracket thickness is greater than 8 mm

Fixing ladder to supports

Use M10 high tensile hexagon head setscrews. Screws should be 20 mm long for shallow channel and 35 mm long for deep channel.

5 Cantilever arms

Maximum uniformly distributed loads for individual cantilever arms are given on page 102. However, should the loading not be uniform then the safe limit can be obtained by calculating the bending moment produced by the intended loads and comparing this with the maximum permissible bending moment for the relevant arm.

45 kgf.m for SA750 - SA755 and SA757

52 kgf.m for SA760 - SA766

95 kgf.m for SA770 - SA776

To obtain the bending moment resulting from any point load, multiply the size of the load by its distance from the inner end of the arm (see illustration A).

If several point loads exist then the total bending moment will be the sum of the individual bending moment produced by each point load (see illustration B).

If some part of the total load applied to an arm is uniformly distributed along a section of the arm only, then this part load can be treated as a point load acting at the mid-point of that section of arm to which it is applied (see illustration C).

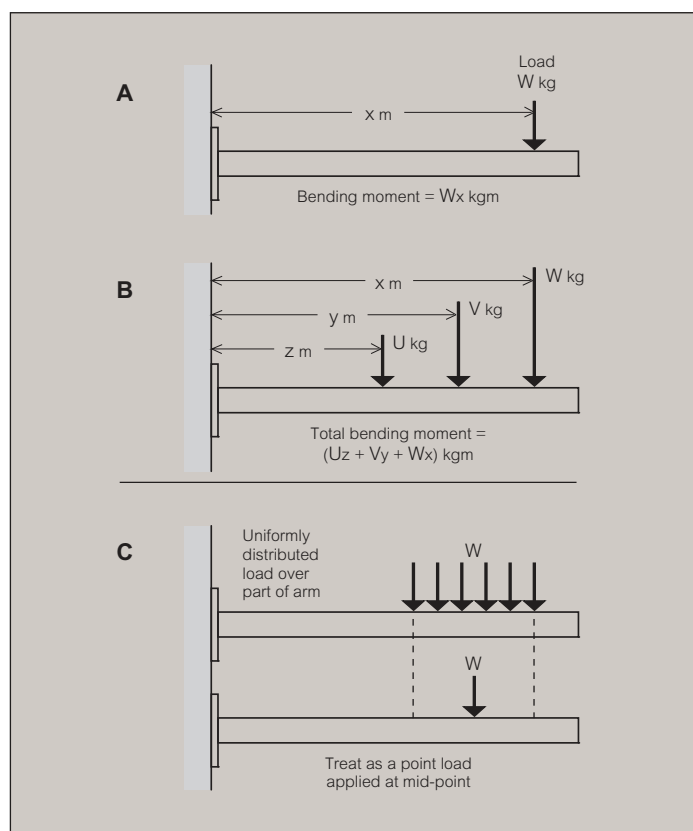

Note

Assumes loads are rigidly fixed to cantilever arms in such a way as to prevent the arms from twisting.

6 Maximum safe recommended loadings

(Based upon a load factor of 1.6 for hot dip galvanised unrestrained condition as specified in BS EN 1993 - 1-3 : 2006)

Cantilever arms

Cat. Nos.	Unit weight (kg)	Arm length (mm)	Maximum uniformly distributed load (kgf)	Point load at outer end (kgf)
SA750	0.64	150	350 ⁽¹⁾	303
SA751	0.85	225	350 ⁽¹⁾	198
SA752	1.03	300	304	152
SA753	1.42	450	202	101
SA754	1.81	600	150	75
SA755	2.20	750	110	55
SA757	2.60	900	90	45



Values assume the ladder or other loading medium is rigidly fixed to cantilever arm

Cantilever arms, universal

Cat. Nos.	Unit weight (kg)	Arm length (mm)	Maximum uniformly distributed load (kgf)	Point load at outer end (kgf)
SA760	0.64	150	700 ⁽¹⁾	350
SA761	0.85	225	456 ⁽¹⁾	228
SA762	1.03	300	350	175
SA763	1.42	450	230	115
SA764	1.81	600	170	85
SA765	2.20	750	136	68
SA766	2.60	900	110	55

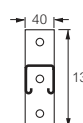

Values assume the ladder or other loading medium is rigidly fixed to cantilever arm

Cantilever arms, double channel

Cat. Nos.	Unit weight (kg)	Arm length (mm)	Maximum uniformly distributed load (kgf)	Point load at outer end (kgf)
SA770	1.14	150	700 ⁽¹⁾	648
SA771	1.68	225	700 ⁽¹⁾	420
SA772	2.02	300	650	325
SA773	2.90	450	430	215
SA774	3.78	600	320	160
SA775	4.66	750	250	125
SA776	5.60	900	200	100

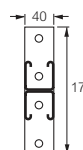

Values assume the ladder or other loading medium is rigidly fixed to cantilever arm

Note

The loads for stainless steel cantilever arms are 60% of those given in the tables, except those marked (1) where the limit is 50%.

Cantilever arm loads detailed in the tables above are for M12 screws and channel nuts.

Assumes loads are rigidly fixed to cantilever arms in such a way as to prevent the arms from twisting.

7 Channels used as beams

The maximum safe load for a channel can be calculated knowing the strength of the steel (yield stress). Alternatively, if the appearance of the channel under load is considered important, then its deflection can be kept within visually acceptable limits.

Deflection limitations may render a lower recommended loading than that calculated from the strength of the steel.

Thus the two alternative approaches are:

- 1) To apply a maximum mid-span deflection of 1/200th of the span.
- 2) To place no limit on deflection and to apply a maximum load derived from calculations which include both the minimum yield stress of the steel and a safety factor (1.6).

Details of the maximum recommended uniformly distributed and point loads under both of these conditions are given in the table on page 139; these are provided for both restrained and unrestrained conditions (see opposite) and they apply to the worst situation of a simple single span only.

If in practice loads are neither uniformly distributed across the complete beam nor imposed at mid-span only, it is still possible to use a safe approximation and assess the suitability of a channel section. Do this by assuming that all loads are point loads imposed at mid-span only, and then consider the point load data in the table. This approximation will render a cautious result, which is nevertheless sufficient in most cases to show that a channel is satisfactory.

However, if it does yield an unsatisfactory result check with Legrand, as the degree of inherent caution is such that the design may still be safe. Legrand will be pleased to recheck your calculations, using your intended loadings.

The data provided in the table on page 139 is calculated in accordance with BS 5950 Part 5.

8 Channels used as columns

It is rare that any loads will be applied only to the end of a vertical column; most practical loading conditions involve the use of brackets and fittings attached to the open side of the channel. Loads applied in this way will produce a combined axial force down the column and a bending force on the side of the column which will reduce the allowable maximum load. The effects of such eccentric loadings should be carefully checked in accordance with standard design practice as given in BS 5950 Part 5.

Legrand will be pleased to give further advice and assistance on request.

9 Fully restrained and unrestrained loads

There are two alternative approaches to providing information on the structural strength of channel section used as beams.

Data is sometimes given on the basis of a fully restrained condition, which assumes that the channel section is in some way completely prevented from twisting under load (see illustration A). Alternatively data may be given on the basis of an unrestrained condition which assumes that, because no channel is perfect, placing it under load may result in some twisting taking place even though the ends of the channel are firmly secured (see illustration B).

Because the channel is constrained to remain in the optimum position, data given on a fully restrained basis will, for larger spans, suggest that a far higher load can be applied than with the unrestrained condition.

Both alternative sets of data are given in the table on page 139; however, unless positive intermediate restraint is applied to completely prevent any twisting it is recommended that the data for unrestrained channels, given in the table opposite, should normally be used.

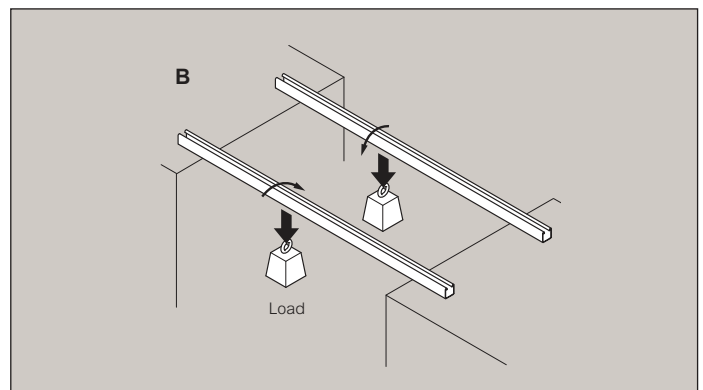
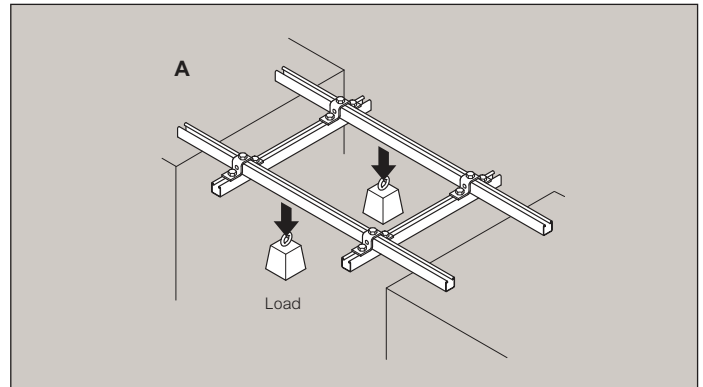

10 Beam loads

Cat. Nos.	Distance between supports (m)	Laterally unrestrained condition				Fully laterally restrained condition			
		Safe maximum loads		Maximum deflection of span/200		Safe maximum loads		Maximum deflection of span/200	
		Uniformly distributed across span (kgf)	Point load at mid-span (kgf)	UD load (kgf)	Point load at mid-span (kgf)	Uniformly distributed across span (kgf)	Point load at mid-span (kgf)	UD load (kgf)	Point load at mid-span (kgf)
SC400	0-20	700 ⁽²⁾	700 ⁽²⁾	700 ⁽²⁾	700 ⁽²⁾	700 ⁽²⁾	700 ⁽²⁾	700 ⁽¹⁾	700 ⁽¹⁾
SC200	0-20	687	343	687 ⁽¹⁾	343 ⁽¹⁾	687	343	687 ⁽¹⁾	343 ⁽¹⁾
SC401	0-20	700 ⁽²⁾	700 ⁽²⁾	700 ⁽²⁾	700 ⁽²⁾	700 ⁽²⁾	700 ⁽²⁾	700 ⁽¹⁾	700 ⁽¹⁾
SC400	0-40	700 ⁽²⁾	561	700 ⁽²⁾	561 ⁽¹⁾	700 ⁽²⁾	561	700 ⁽¹⁾	561 ⁽¹⁾
SC200	0-40	343	171	343 ⁽¹⁾	171 ⁽¹⁾	343	171	343 ⁽¹⁾	171 ⁽¹⁾
SC401	0-40	700 ⁽²⁾	700 ⁽²⁾	700 ⁽²⁾	700 ⁽²⁾	700 ⁽²⁾	700 ⁽²⁾	700 ⁽¹⁾	700 ⁽¹⁾
SC400	0-60	700	374	747 ⁽¹⁾	374 ⁽¹⁾	747	374	700 ⁽¹⁾	374 ⁽¹⁾
SC200	0-60	226	113	226 ⁽¹⁾	113 ⁽¹⁾	228	114	228 ⁽¹⁾	114 ⁽¹⁾
SC401	0-60	700 ⁽²⁾	700 ⁽²⁾	700 ⁽²⁾	700 ⁽²⁾	700 ⁽²⁾	700	700 ⁽¹⁾	700 ⁽¹⁾
SC400	0-80	543	271	543 ⁽¹⁾	271 ⁽¹⁾	560	280	560 ⁽¹⁾	280 ⁽¹⁾
SC200	0-80	164	82	134	82 ⁽¹⁾	170	85	134	84
SC401	0-80	700 ⁽²⁾	700	700 ⁽²⁾	700 ⁽¹⁾	700 ⁽²⁾	700	700 ⁽¹⁾	700 ⁽¹⁾
SC400	1-00	419	210	419 ⁽¹⁾	210 ⁽¹⁾	447	223	447 ⁽¹⁾	223 ⁽¹⁾
SC200	1-00	126	63	85	53	136	68	85	53
SC401	1-00	700 ⁽²⁾	548	700 ⁽²⁾	548 ⁽¹⁾	700 ⁽²⁾	582	700 ⁽¹⁾	582 ⁽¹⁾
SC400	1-20	336	168	336 ⁽¹⁾	168 ⁽¹⁾	371	186	371 ⁽¹⁾	186 ⁽¹⁾
SC200	1-20	101	50	58	36	113	56	58	36
SC401	1-20	700 ⁽²⁾	440	700 ⁽²⁾	440 ⁽¹⁾	700	484	700 ⁽¹⁾	484 ⁽¹⁾
SC400	1-40	275	138	271	138 ⁽¹⁾	317	159	271	159 ⁽¹⁾
SC200	1-40	83	41	42	26	96	48	42	26
SC401	1-40	700	361	700 ⁽¹⁾	361 ⁽¹⁾	700	414	700 ⁽¹⁾	414 ⁽¹⁾
SC400	1-60	230	115	206	115 ⁽¹⁾	277	139	206	129
SC200	1-60	69	35	31	19	83	42	31	19
SC401	1-60	604	302	604 ⁽¹⁾	302 ⁽¹⁾	700	362	700 ⁽¹⁾	362 ⁽¹⁾
SC400	1-80	194	97	162	97 ⁽¹⁾	245	123	162	101
SC200	1-80	59	29	23	15	73	37	23	15
SC401	1-80	510	255	510 ⁽¹⁾	255 ⁽¹⁾	641	321	641 ⁽¹⁾	321 ⁽¹⁾
SC400	2-00	165	83	130	81	220	110	130	81
SC200	2-00	51	25	18	11	66	33	18	11
SC401	2-00	434	217	434 ⁽¹⁾	217 ⁽¹⁾	575	288	575 ⁽¹⁾	288 ⁽¹⁾
SC400	2-20	142	71	106	66	199	100	106	66
SC200	2-20	44	22	14	9	59	29	14	9
SC401	2-20	371	186	371 ⁽¹⁾	186 ⁽¹⁾	521	261	521 ⁽¹⁾	261 ⁽¹⁾
SC400	2-40	123	61	87	55	182	91	87	55
SC200	2-40	38	19	11	7	53	27	11	7
SC401	2-40	319	160	319 ⁽¹⁾	160 ⁽¹⁾	476	238	460	238 ⁽¹⁾
SC400	2-60	107	53	73	46	167	83	73	46
SC200	2-60	33	17	8	5	49	24	8	5
SC401	2-60	276	138	276 ⁽¹⁾	138 ⁽¹⁾	436	219	389	219 ⁽¹⁾
SC400	2-80	94	47	61	38	154	77	61	38
SC200	2-80	29	15	6	4	45	22	6	4
SC401	2-80	240	120	240 ⁽¹⁾	120 ⁽¹⁾	405	202	333	202 ⁽¹⁾
SC400	3-00	82	41	52	33	143	71	52	33
SC200	3-00	25	13	4	3	41	21	4	3
SC401	3-00	209	105	209 ⁽¹⁾	105 ⁽¹⁾	376	188	286	179

Column loads

Section	Maximum axial column load (kgf)	Column height (m)	(kgf)
SC400	0-20	6325	
SC200	0-20	4279	
SC401	0-20	11475	
SC400	0-40	6217	
SC200	0-40	3850	
SC401	0-40	11375	
SC400	0-60	5982	
SC200	0-60	2879	
SC401	0-60	11041	
SC400	0-80	5640	
SC200	0-80	1867	
SC401	0-80	10621	
SC400	1-00	5102	
SC200	1-00	1253	
SC401	1-00	10035	
SC400	1-20	4346	
SC200	1-20	891	
SC401	1-20	9193	
SC400	1-40	3549	
SC200	1-40	664	
SC401	1-40	8088	
SC400	1-60	2872	
SC200	1-60	513	
SC401	1-60	6889	
SC400	1-80	2345	
SC200	1-80	408	
SC401	1-80	5792	
SC400	2-00	1938	
SC200	2-00	332 ⁽³⁾	
SC401	2-00	4874	
SC400	2-20	1625	
SC200	2-20	276 ⁽³⁾	
SC401	2-20	4131	
SC400	2-40	1381	
SC200	2-40	233 ⁽³⁾	
SC401	2-40	3534	
SC400	2-60	1186	
SC200	2-60	199 ⁽³⁾	
SC401	2-60	3051	
SC400	2-80	1030	
SC200	2-80	172 ⁽³⁾	
SC401	2-80	2658	
SC400	3-00	902	
SC200	3-00	150 ⁽³⁾	
SC401	3-00	2335	

Note to tables

(1) Based on a limited deflection of $\frac{\Delta_0}{200}$, the safe maximum load value is given which will give a deflection of $< \frac{\Delta_0}{200}$

(2) Limited by slip on a single bolt connection each end

(3) For columns, the limiting slenderness ratio of 180 is exceeded at the length indicated

(4) It should be noted that maximum axial column loads are supplied for guidance only. It is unlikely that columns will be loaded with axial load only. Most practical load conditions will involve the use of brackets and fittings attached to the column. Loads applied in this way will produce both axial load and bending on the columns which will reduce the allowable maximum load

The above loads have been treated as imposed loads in accordance with

BS 5950 Part 5 and accordingly a load factor of $f = 1.6$ has been assumed. Should the loads to be applied be of a permanent nature it may be appropriate to use a load factor of $f = 1.4$. This would lead to an increase in the load capacity provided that capacity is not limited by bolt slip or deflection

Loads given in the chart are for pre-galvanised channels to BS EN 10346 grade S250GD Z275. The process of manufacturing channel increases the strength of the steel and this increase has been allowed for in the data (as recommended in BS 5950 Part 5). However, if channels are subsequently hot dip galvanised the stresses created during manufacture are relieved by the heat of the process, thereby negating the strength enhancement

Therefore for hot dip galvanised channels the loads in the chart should be reduced by between 10% and 20% depending on the section. A 20% reduction will provide a conservative maximum load value for all types of hot dip galvanised channel

All loads are for brackets fixed with M12 setscrews and M12 zinc plated channel nuts

Packaging, handling, storage and safety

IN THIS SECTION...

- Export packaging
- Handling and storage
- Safety during installation phase

Export packaging

Safe handling

All Legrand products can be supplied packed appropriately for any mode of shipment.

The various packing options are illustrated below.

Further details and packing recommendations are available from Legrand, contact us on +44 (0) 845 605 4333.

Even when appropriately packed it is most important that equipment is correctly loaded.

All equipment must be properly secured against movement during transit otherwise damage may occur during the journey.

Containerised seafreight

Straight lengths

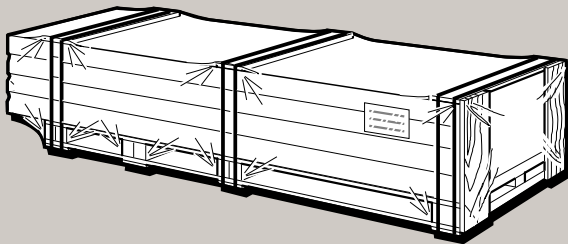

- The specially designed wooden framework enables lifting of the pallet by fork lift vehicle from either side or one end only. It is also designed to prevent insertion of the forks between components which will cause damage.
- Equipment is steel strapped to the wooden framework. If required the complete assembly is shrink wrapped in heavy duty polythene.
- Shipping marks are applied to meet with contract requirements.

Cable ladder and support system accessories

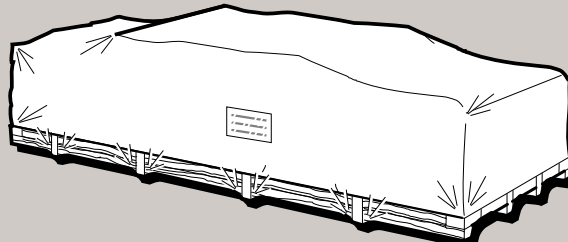

- The specially designed wooden framework enables lifting of the pallet by fork lift vehicle from either side or one end only. It is also designed to prevent insertion of the forks between components which will cause damage.
- Equipment is steel strapped to the wooden framework. The complete assembly is shrink wrapped in heavy duty polythene.
- Shipping marks are applied to meet with contract requirements.

Non-containerised seafreight, road or airfreight

Straight lengths

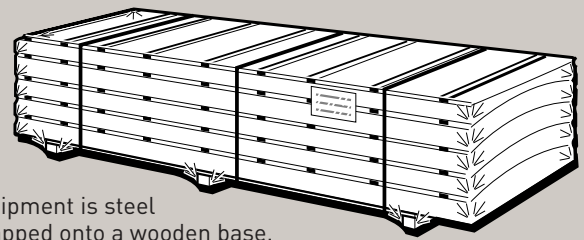

Equipment is steel strapped onto a wooden base.

If required the complete assembly is shrink wrapped in heavy duty polythene.

Shipping marks are applied to meet with contract requirements.

Specialised packing

Legrand can also supply equipment packed in wooden crates or wooden cases for shipment to destinations where transhipment or rough handling en route is likely or where transport over rough terrain is anticipated.

Wooden casing

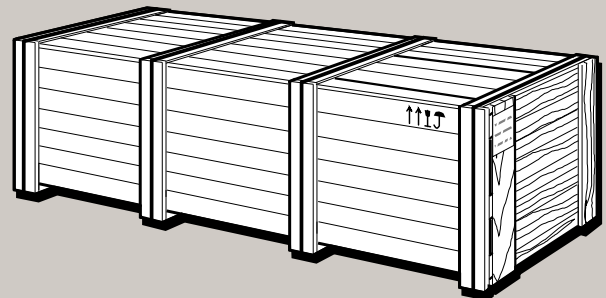

Equipment is steel strapped in suitable stacks.

Stacks are then tightly packed within a case constructed from close wooden boards with no gaps.

Wooden crating

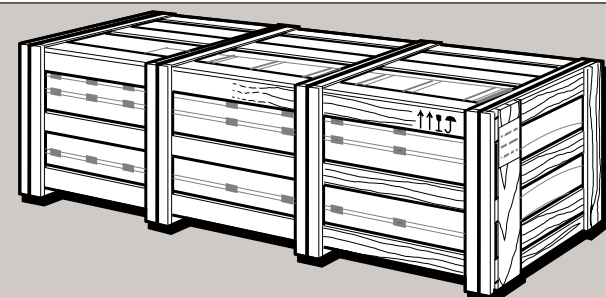

Equipment is steel strapped in suitable stacks.

Each stack is then shrink wrapped in heavy duty polythene. Stacks are then tightly packed within a wooden crate.

Handling and storage

Safe handling

Site deliveries will only be made provided suitable mechanical handling equipment is available on site.

The delivered material must be treated with care. Lifting must only be carried out from the sides and lifting forks must pass below a complete stack. Forks must never be inserted into the end of the stack (unless goods are packed in special containerisation crates, see Export Packaging on page 140); this practice is likely to cause the safety limits of most lifting vehicles to be exceeded and will certainly cause damage to the equipment being lifted.

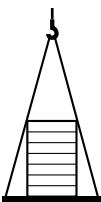

For offloading by crane suitable lifting beams should be inserted from side to side beneath a stack and these must be sufficiently long to avoid undue pressure on the edges of the bottom components.



The tensioned banding used for securing bundles of equipment during transport is not suitable for lifting purposes. When cutting this banding appropriate eye protection must be worn to avoid injury.



Sheared steel (particularly pre-galvanised or stainless steel) does have relatively sharp edges and protective gloves must be worn during handling.

Storage

Most support equipment is supplied with a corrosion resistant finish (often hot dip galvanising) which will, once the equipment is erected and open to the air, have a service life of many years. However if hot dip galvanised equipment is allowed to become wet whilst stacked awaiting installation the finish can quickly suffer from unsightly staining and powdering on the surface. This is known as Wet storage stain (see below) and the effects are particularly exaggerated if products are left in back to back contact.

It is therefore essential that all support system equipment is stored in a dry, unheated environment and that the following precautions are observed to prevent deterioration on site :

- Any outer packaging should be removed from stacks immediately following delivery, before the goods are placed in store.
- Store all support equipment under cover, in dry, unheated premises. Do not leave any uncovered, part-used stacks lying outside for long periods.
- If stacks of equipment have become wet they must be re-stacked as soon as possible with wooden battens inserted between components to allow air to circulate.
- If no undercover storage is available then equipment should be re-stacked as in (c) immediately following delivery and a simple shelter, using polythene or a tarpaulin, should be erected over the stored equipment to protect it from rain. This covering should not be laid directly onto the stack as air must be allowed to circulate through and around the stored goods.
- Inspect stored goods regularly to ensure that moisture has not penetrated into the stacks.
- Do not store the delivered material where people will walk across it.

Wet storage stain

Failure to comply with the above storage conditions may result in galvanised material being quickly disfigured by Wet storage stain. Fortunately this problem is rarely serious and (unless the poor storage conditions have continued unchecked for several months) it has no significant effect on the long term corrosion resistance of the finish. Where equipment has been affected by Wet storage stain the unsightly marking will usually become much less prominent and will often disappear completely within months of installation.

Safety during installation phase

Site safety

Heavy duty cable ladders are designed for rugged conditions and can withstand some abuse. However they are not designed or intended for use as walkways or scaffolds and proper working platforms or temporary access scaffolding must be provided for the use of installation personnel.

Control of hazardous substances



Legrand cable management support systems will have a surface coating of either zinc, light oil or a plastic material, depending upon the specified finish.



If any welding of equipment is carried out these substances can give rise to fumes and so appropriate ventilation must be provided to ensure the exposure of the operator is kept below the statutory limits.



The current occupational exposure limits for zinc oxide fumes published by the U.K. Health & Safety Executive are 10mg/m³ for short term exposure and 5mg/m³ for long term exposure.

Relevant British, European and International standards

Standard Type	BS No	Part	Title
BS	1140	0	Specification for resistance spot welding of uncoated and coated low carbon steel.
BS EN	1179	0	Zinc and zinc alloys. Primary zinc.
BS EN ISO	1461	0	Hot dip galvanised coatings on fabricated iron and steel articles – specifications and test methods.
BS	7371	3	Coatings on metal fasteners. Specification for electroplated zinc coatings
BS EN ISO	2081	0	Metallic and other inorganic coatings. Electroplated coatings of zinc with supplementary treatments on iron or steel
BS EN ISO	3506	1	Mechanical properties of corrosion resistant stainless steel fasteners. Part 1, Bolts, Screws and Studs.
BS EN ISO	3506	2	Mechanical properties of corrosion resistant stainless steel fasteners. Part 2 Nuts.
BS	3692	0	ISO metric precision hexagon bolts, screws and nuts. Specification.
BS	4320	0	Specification for metal washers for general engineering purposes. Metric series.
BS	4872	1	Specification for approval testing of welders when welding procedure approval is not required. Fusion welding of steel.
BS	5950	5	Structural use of steelwork in building.
BS	6338	0	Chromate conversion coatings on electroplated zinc and cadmium coatings.
PD	6484	0	Commentary on corrosion at bimetallic contacts and its alleviation.
BS	6946	0	Specification for metal channel cable support systems for electrical installations.

Standard Type	BS No	Part	Title
BS	7671	0	Requirements for electrical installations. IEE Wiring Regulations. Seventeenth Edition.
BS EN ISO	9000		Quality management systems - fundamentals and vocabulary.
BS EN ISO	9001		Quality management systems - requirements.
BS EN ISO	9004		Quality management systems - guidelines for performance improvements.
BS EN	10025	2	Hot rolled products of structural steels. Technical delivery conditions for non alloy structural steels.
BS EN	10025	5	Hot rolled products of structural steels. Technical delivery conditions for structural steels with improved atmospheric corrosion resistance.
BS EN	10088	1	Stainless steels. Part 1: List of stainless steels.
BS EN	10088	2	Stainless steels. Part 2: Technical delivery conditions for steel sheet/plate and strip of corrosion resisting steels for general purposes.
BS EN	10088	3	Stainless steels. Part 3: Technical delivery conditions for semi-finished products, bars, rods, wire, sections and bright products of corrosion resisting steels for general purposes.
BS EN	10346	0	Continuously hot-dip coated steel flat products. Technical delivery conditions.
BS EN ISO	12944	5	Paints and varnishes - Corrosion protection of steel structures by protective paint systems. Part Protective paint systems.
BS EN ISO	14713	1	Zinc coatings. Guidelines and recommendations for the protection against corrosion of iron and steel in structures. General principles of design and corrosion resistance.
BS EN ISO	14713	2	Hot dip galvanising. Guidelines and recommendations for the protection against corrosion of iron and steel in structures. General principles of design and corrosion resistance.
IEC	61537	0	Cable Tray systems and cable ladder systems for cable management.
BS EN	1991	1.3	Eurocode 1 : Action on structures. General actions : snow loads
BS EN	1991	1.4	Eurocode 1 : Action on structures. General actions : wind loads
BS EN	1993	1.3	Eurocode 3 : Design of steel structures. General rules. Supplementary rules for cold-formed members and sheeting.

Cat. Nos.	Page No.	Cat. Nos.	Page No.	Cat. Nos.	Page No.	Cat. Nos.	Page No.	Cat. Nos.	Page No.	Cat. Nos.	Page No.
500000		EL450F	18	PL900F	16	SA773	26	SC852/21	28	ZCURF	22
		EL600F	-	PLFEB	21	SA774	-	SC852/41	-	ZDVF	-
		EL750F	-	PLRWKF	17	SA775	-	SC852/82	-	ZEF	21
5572 33	31	EL900F	-	PN060	25	SA776	-	SC853	-	ZFBWArF	14
5572 43	-	ELRWKF	-	PN061	-	SA790	-	SC854	-	ZFCF	-
5572 53	-	ENF	21	PN062	-	SA791	-	SC855	-	ZFF	21
5572 63	-	EORWArF	18	PN080	-	SA792	-	SC856	-	ZHF	-
5572 73	-	EORCWArF	23	PN081	-	SA793	-	SC950B	-	ZIRWArF	14
5572 83	-	EORVWArF	-	PN082	-	SA794	-	SC950W	-	ZIRCWArF	23
		EPF	21	PN100	-	SA795	-	SC951B	-	ZIRVWArF	-
		ERBF	20	PN101	-	SA796	-	SC951W	-	ZJF	21
8000000		ERYF	23	PN102	-	SB500	27	SC952	-	ZL150F	14
		ERRWKF	19	PN120	-	SB501	-	SC953	-	ZL300F	-
87665 02	31	ESRWKF	-	PN121	-	SB502	-	SP960	-	ZL450F	-
87665 03	-	ESWF	22	PN122	-	SB503	-	SP964	-	ZL600F	-
87665 04	-	ETBF	-	PNF	21	SB504	-	SP965	-	ZL750F	-
87665 05	-	ETWArF	19	PORWArF	16	SB505	-	SP968	-	ZL900F	-
87665 06	-	EUTWBrF	-	PORCWArF	23	SB50606	-	SP969	-	ZLRWKF	15
87665 07	-	EVF	22	PORVWArF	-	SB50608	-	SP972	-	ZNF	21
87665 08	-	EWSBF	20	PPF	21	SB50610	-	SP973	-	ZORWArF	14
87665 09	-	EXWArF	19	PRYF	23	SB50612	-	SP975	-	ZORCWArF	23
87665 10	-			PRBF	20	SB507	-	SP976	-	ZORVWArF	-
87665 11	-			PRRWKF	17	SB508	-	SS0616	24	ZPF	21
87665 12	-	F		PSRWKF	-	SB509	-	SS0620	-	ZRYF	23
87665 13	-			PSWF	22	SB510	-	SS0625	-	ZRBF	20
87665 14	-	FL2	28	PTBF	-	SB511	-	SS0630	-	ZRRWKF	15
87665 15	-	FW06	24	PTWArF	17	SB513	-	SS0820	29	ZSRWKF	-
87665 16	-	FW08	-	PUTWBrF	-	SB514	-	SS0825	-	ZSWF	22
87665 18	-	FW10	-	PVF	22	SB515	-	SS0830	-	ZTWArF	-
87665 20	-	FW12	-	PW06	30	SB518	28	SS0835	-	ZTBF	-
87665 30	-			PW08	-	SB520	27	SS0840	-	ZUTWBrF	15
87665 45	-			PW10	-	SB524	-	SS0850	-	ZVF	22
87665 50	-	H		PW12	-	SB526	-	SS1016	24	ZWSBF	20
87665 60	-			PWSBF	20	SB528	-	SS1020	-	ZXWArF	15
87665 70	-	HCAWF	20	PXWArF	17	SB532	-	SS1025	-		
		HN06	24			SB534	-	SS1030	-		
A		HN08	-	R		SB536	27	SS1035	-		
		HN10	24			SB550	-	SS1040	-		
		HN12	-			SB551	-	SS1045	-		
AMBWF	23	HTHWF	20	RB0612	24	SB552	-	SS1050	-		
C		L		RB0612S	-	SB554	-	SS1060	-		
				RB0616	-	SB555	-	SS1220	-		
CSBF	23	LFGM10P50	14	RB0616S	-	SB556	-	SS1225	-		
CP1035	29	LFSM10P50	-	RB0620	-	SB600	28	SS1230	-		
CP1035S	-			RB0620S	-	SB601	-	SS1235	-		
CVWF	23			RB0625	-	SB602	-	SS1240	-		
		M		RB0630	-	SB603	27	SS1250	-		
D				RB0640	-	SB603+	-	SSG0612	29		
		MF	22	RB0650	-	SB606	-	SSG0616	24		
DOWF	22	MPF	23	RBG0612	-	SB607	-	SSG0620	-		
E		P		RBG0616	-	SB650	28	SSG0625	-		
				RC06	-	SB651	-	SSG0630	-		
EARWF	22	PARWF	22	RC08	-	SB700	-	SSG0635	29		
EB06	30	PBF	20	RC10	-	SB701	-	SW06	-		
EB08	-	PBW300RF	17	RC12	-	SB702	-	SW08	-		
EB10	-	PCF	-	RWG06	30	SB703	-	SW10	-		
EBF	20	PCURF	22			SB704	-	SW12	-		
EBW300RF	19	PDVF	-	S		SB705	-				
ECF	18	PFCF	16	SA750	26	SB706	-	T			
ECURF	22	PEF	21	SA751	-	SB707	-	TR06	24		
EDVF	-	PFBWArF	16	SA752	-	SC2003M	25	TR08	-		
EEF	21	PFF	21	SA753	-	SC2006M	-	TR10	-		
EFBWArF	18	PHF	-	SA754	-	SC2033M	-	TR12	-		
EFCF	-	PIRWArF	16	SA755	-	SC2036M	-	TW06	30		
EFF	21	PIRCWArF	23	SA757	-	SC2103M	-	TWG06	-		
EHF	-	PIRVWArF	-	SA760	-	SC2133M	-				
EIRWArF	18	PJF	21	SA761	-	SC4003M	-				
EIRCWArF	23	PL150F	16	SA762	-	SC4006M	-				
EIRVWArF	-	PL300F	-	SA763	-	SC4013M	-				
EJF	21	PL450F	-	SA764	-	SC4016M	-				
EL150F	18	PL600F	-	SA765	-	SC4033M	-				
EL300F	-	PL750F	-	SA766	-	SC4036M	-				
				SA770	-	SC4103M	-				
				SA771	-	SC4133M	-				
				SA772	-	SC850	28				
						SC851	-				
								ZARWF	22		
								ZBF	20		
								ZBW300RF	15		
								ZC1	28		
								ZCF	14		



LEGRAND WORLDWIDE

- Algeria**
Legrand
Tel. : (213) 21 91 38 32
Fax : (213) 21 91 26 39
- Australia**
Legrand
Tel. : (61) 2 87 19 43 33
Fax : (61) 2 87 19 43 45
- Austria**
Legrand Osterreich
Tel. : (43) 1 277 62
Fax : (43) 1 277 62 225
- Belarus**
Legrand
Tel. : (375) 17 205 04 78/79
Fax : (375) 17 205 04 78/79
- Belgium**
Legrand Belgique S.A.
Tel. : (32) 2 719 17 11
Fax : (32) 2 719 17 00
- Bosnia-Herzegovina**
Legrand
Tel. : (387) 33 71 10 25
Fax : (387) 33 52 17 84
- Brazil**
GL Electro-Eletronicos Ltda
Tel. : (55) 11 56 44 26 00
Fax : (55) 11 51 81 06 04/59 14
- Bulgaria**
Legrand
Tel. : (359) 2 489 92 97
Fax : (359) 2 489 94 70
- Canada**
Pass & Seymour Canada Inc
Tel. : (1) 905 738 91 95
Fax : (1) 905 738 97 21
- Chile**
Legrand Electro Andina Ltda (EAL)
Tel. : (56) 2 550 52 00
Fax : (56) 2 550 53 09
- China**
Legrand China
Tel. : (86) 21 52 11 01 11
Fax : (86) 21 52 11 00 86
- Colombia**
Legrand Colombia S.A.
Tel. : (57) 1 437 67 00
Fax : (57) 1 436 26 54
- Costa Rica**
Bticino Costa Rica
Tel. : (506) 22 98 56 00
Fax : (506) 22 39 04 72
- Croatia**
Legrand
Tel. : (385) 1 606 43 50
Fax : (385) 1 606 43 59
- Cyprus**
Legrand
Tel. : (357) 22 318 588
Fax : (357) 22 318 588
- Czech Republic**
Legrand s.r.o.
Tel. : (420) 2 46 00 76 68
Fax : (420) 2 46 00 76 69
- Egypt**
EMB Electrical Industries SAE
Tel. : (202) 23 78 61 50
Fax : (202) 23 80 70 32
- Estonia**
Legrand SNC
Tel. : (372) 67 99 110
Fax : (372) 67 99 113
- France**
Legrand S.A.
Tel. : (33) 5 55 06 87 87
Fax : (33) 5 55 06 88 88
- Germany**
Legrand GmbH
Tel. : (49) 29 21 10 40
Fax : (49) 29 21 10 42 02
- Greece**
Helliniki Legrand S.A.
Tel. : (30) 2 10 67 97 500
Fax : (30) 2 10 67 97 540
- Hong Kong**
Legrand (HK) Ltd
Tel. : (852) 26 87 42 00
Fax : (852) 26 87 43 00
- Hungary**
Legrand Zrt
Tel. : (36) 63 51 02 00
Fax : (36) 63 51 02 10
- India**
Legrand (India) Pvt Ltd
Tel. : (91) 22 30 41 62 00
Fax : (91) 22 24 93 31 58
- Indonesia**
PT Legrand Indonesia
Tel. : (62) 21 525 06 08
Fax : (62) 21 525 59 35
- Iran**
Alborz Electrical Industries Ltd
Tel. : (98) 218 873 94 57/86 70
Fax : (98) 218 873 79 03
- Italy**
Bticino S.p.a.
Tel. : (39) 03 32 27 91 11
Fax : (39) 03 32 26 56 61
- Jordan**
Legrand
Tel. : (962) 64 65 59 02
Fax : (962) 64 65 59 03
- Kazakhstan**
Legrand Kazakhstan
Tel. : (7) 32 72 26 03 63
Fax : (7) 32 72 26 03 63
- Korea**
Anam Legrand Co. Ltd
Tel. : (82) 25 50 32 00
Fax : (82) 25 50 32 99
- Kuwait**
Legrand
Tel. : (965) 22 25 18 20
Fax : (965) 22 25 18 19
- Lebanon**
Legrand
Tel. : (961) 1 422 166
Fax : (961) 1 422 167
- Lithuania**
Legrand
Tel. : (370) 523 56 500
Fax : (370) 523 56 700
- Malaysia**
Legrand
Tel. : (603) 62 04 06 88
Fax : (603) 62 04 07 88
- Mauritius**
Legrand
Tel. : (230) 249 14 00
Fax : (230) 249 15 00
- Mexico**
Bticino Mexico S.A. of C.V.
Tel. : (52) 442 238 04 00
Fax : (52) 442 238 04 82
- Morocco**
Simapel
Tel. : (212) 2 235 93 73
Fax : (212) 2 235 58 30
- Netherlands**
Legrand Netherlands B.V.
Tel. : (31) 411 653 111
Fax : (31) 411 653 158
- New Caledonia**
Legrand
Tel. : (687) 76 49 28
Fax : (687) 25 95 64
- New Zealand**
HPM Legrand
Tel. : (64) 9 442 08 000
Fax : (64) 9 442 08 003
- Ouzbekistan**
Legrand
Tel. : (998) 71 138 9948
Fax : (998) 71 138 9947
- Peru**
Bticino del Peru S.A.
Tel. : (51) 1242 60 00
Fax : (51) 1242 41 00
- Philippines**
Bticino Philippines Inc.
Tel. : (63) 2 89 28 972
Fax : (63) 2 89 28 971
- Poland**
Legrand Polska
Tel. : (48) 748 162 300
Fax : (48) 748 152 149
- Portugal**
Legrand Electrica S.A.
Tel. : (351) 21 454 88 00
Fax : (351) 21 454 88 86
- Qatar**
Legrand
Tel. : (974) 456 90 83
Fax : (974) 465 99 16
- Reunion**
Legrand Indian Ocean
Tel. : 02 62 90 01 80
Fax : 02 62 90 01 89
- Romania**
Legrand Romania SRL
Tel. : (40) 21 232 07 77
Fax : (40) 21 232 07 76
- Russia**
Firelec Legrand P.T.
Tel. : (7) 495 660 75 50/60
Fax : (7) 495 660 75 51/61
- Saudi Arabia**
Legrand
Tel. : (966) 2 651 28 48
Fax : (966) 2 651 74 34
- Senegal**
Legrand
Tel. : (221) 33 865 00 01
Fax : (221) 33 820 63 69
- Serbia and Montenegro**
Legrand
Tel. : (381) 11 26 05 308
Fax : (381) 11 26 05 267
- Singapore**
Legrand (S) Pte Ltd
Tel. : (65) 6416 1550
Fax : (65) 6416 1580
- Slovakia**
Legrand
Tel. : (421) 232 153 601
Fax : (421) 232 153 609
- Slovenia**
Legrand SLV d.o.o.
Tel. : 386 (0) 1 562 01 70
Fax : 386 (0) 1 562 13 12
- South Africa**
Legrand electrical accessories
Tel. : (27) 11 444 79 71
Fax : (27) 11 444 79 80
- Spain**
Legrand Group España
Tel. : (34) 91 656 18 12
Fax : (34) 91 656 67 88
- Switzerland**
Legrand (Suisse) S.A.
Tel. : (41) 56 464 67 67
Fax : (41) 56 464 67 60
- Syria**
Legrand
Tel. : (963) 11 33 22 920/970
Fax : (963) 11 33 22 512
- Thailand**
Bticino (Thailand) Limited
Tel. : (66) 2 656 91 62/67
Fax : (66) 2 656 91 97
- Tunisia**
Legrand
Tel. : (216) 71 964 022
Fax : (216) 71 963 297
- Turkey**
Legrand Elektrik San. A.S.
Tel. : (90) 262 648 90 00
Fax : (90) 262 751 12 67
- U.A.E.**
Legrand SNC FZE
Tel. : (971) 48 137 111
Fax : (971) 48 864 784
- Ukraine**
Legrand Ukraine Ltd
Tel. : (38) 044 494 00 10
Fax : (38) 044 490 67 56
- United States**
Legrand North America
Tel. : (1) 860 233 6251
Fax : (1) 860 570 2813
- Venezuela**
Bticino De Venezuela C.A.
Tel. : (58) 212 361 33 33
Fax : (58) 212 362 25 25
- Vietnam**
Legrand Vietnam
Tel. : (848) 9 307 448
Fax : (848) 9 307 449
- West Indies**
Legrand
Tel. : (0) 5 90 86 18 53
Fax : (0) 5 90 86 23 05
- Other countries :**
www.legrandgroup.com
- International department direct :**
Tel. : 33 5 55 06 87 87
Fax : 33 5 55 06 74 55

Contact details

United Kingdom

Great King Street North,
Birmingham, B19 2LF

Customer Services:

Tel: +44 (0) 845 605 4333 Fax: +44 (0) 845 605 4334
E-mail: legrand.sales@legrand.co.uk

Technical Support:

Tel: +44 (0) 870 608 9020 Fax: +44 (0) 870 608 9021
E-mail: technical.uk@legrand.co.uk

Republic of Ireland:

Tel: 01 295 9673 Fax: 01 295 4671
E-mail: legrand.sales@legrand.co.uk



Distributor:



Head office (UK and Ireland):

Legrand Electric Limited
Great King Street North, Birmingham, B19 2LF
Tel: +44 (0) 870 608 9000 Fax: +44 (0) 870 608 9004
Website: www.legrand.co.uk



This document is printed on sustainably sourced paper. Please recycle.

The Legrand logo is a registered trademark of the Legrand group of companies.