

Property of ASCO Power Technologies™

RELIABILITY

Low Voltage Transfer Switch Fundamentals



Course Code: CEU324
CEU Value: 0.1 CEU



Property of ASCO



Learning Objectives

- What Is A Transfer Switch?
- What Is A Transfer Switch Used For?
- Transfer Switch Design Criteria
- Control Features And Functions
- Types of Transfer Switches
- Transfer Switch Solutions

What is a Transfer Switch?

An automatic transfer switch is an integral component of an emergency power supply system (EPSS).

- The transfer switch allows **safe switching from utility power to standby power** while maintaining isolation of each source from the other.
- The main goal is to provide electrical power to the facility loads (during a power outage) from the standby generator without back feeding that can damage utility equipment and hurt (or kill) utility workers.
- **Automatic transfer switches safeguard data and telecommunication networks**, industrial processes and critical installations such as health care facilities and financial transaction centers.



Codes And Regulations

Code/Standard	Description	Relevance to ATS Purchasing
UL 1008 – Standard for Safety	Product safety testing requirements for transfer switches	UL-Listed ATS required for NEC® compliance
National Electrical Code®	Equipment installation standards	NEC compliance required to satisfy electrical inspections by local authorities
NFPA 110 Standard for Emergency and Standby Power Systems	Standards for backup power systems at facilities with regulated life safety systems	Drives periodic testing and reporting for backup power systems
The Joint Commission	Primary organization for accrediting healthcare facility compliance with codes and regulations	In many states, Joint Commission accreditation required to obtain operating licenses.
Centers for Medicaid and Medicare Services	Requires accreditation/compliance with codes and regulations	Government Healthcare reimbursements contingent upon facility compliance with codes and regulations
Commission on Accreditation for Law Enforcement Agencies	Prescribes backup power standards for regulated public facilities	Compliance required for emergency service facilities, 911 call centers, etc.

Transfer Switch Definition & Types: UL Directive

UL 1008 Safety Standard for Transfer Switch Equipment

An “**Automatic transfer switch**” as covered by these requirements is a device that automatically transfers a common load from a normal supply to an alternate supply in the event of failure of the normal supply, and **automatically returns** the load to the normal supply when the normal supply is restored.

A “**Non-automatic transfer switch**” as covered by these requirements is a device, **operated manually** by a physical action, or electrically by remote control, for transferring a common load between a normal and alternate supply.

Transfer Switch Types

UL 1008 Non-Automatic Transfer Switches

Two Types

1. Electrically Operated
 - a. Uses simple control panel
 - b. Limited accessories and voltage frequency sensing

2. Manually Operated
 - a. No control panel
 - b. Limited accessories
 - c. Manually operated
 - d. No controls or voltage sensing



Major Functions of an Automatic Transfer Switch

1. Carry current continuously
2. Detect Power Failures
3. Initiate Alternate Source
4. Transfer Load
5. Sense Restoration to Normal
6. Re-Transfer to Normal
7. Withstand and Close-On Fault Currents

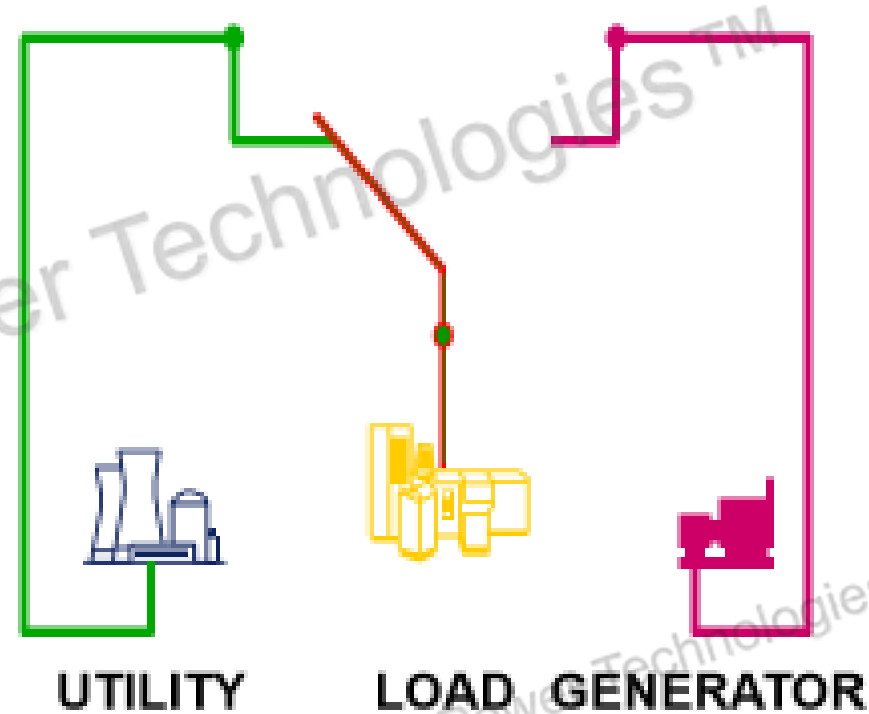

Transfer Switch vs Circuit Breakers

Transfer Switches & Circuit Breakers

An automatic transfer switch connects a critical load to an alternate power source when the normal power source is not acceptable. It must be able to withstand & close-on short circuit currents (WCR).

A circuit breaker's function is to disconnect the circuit and the load from the power source under overcurrent conditions. It must be capable of interrupting or breaking short circuit currents (AIC)

UL1008 Short Circuit Testing

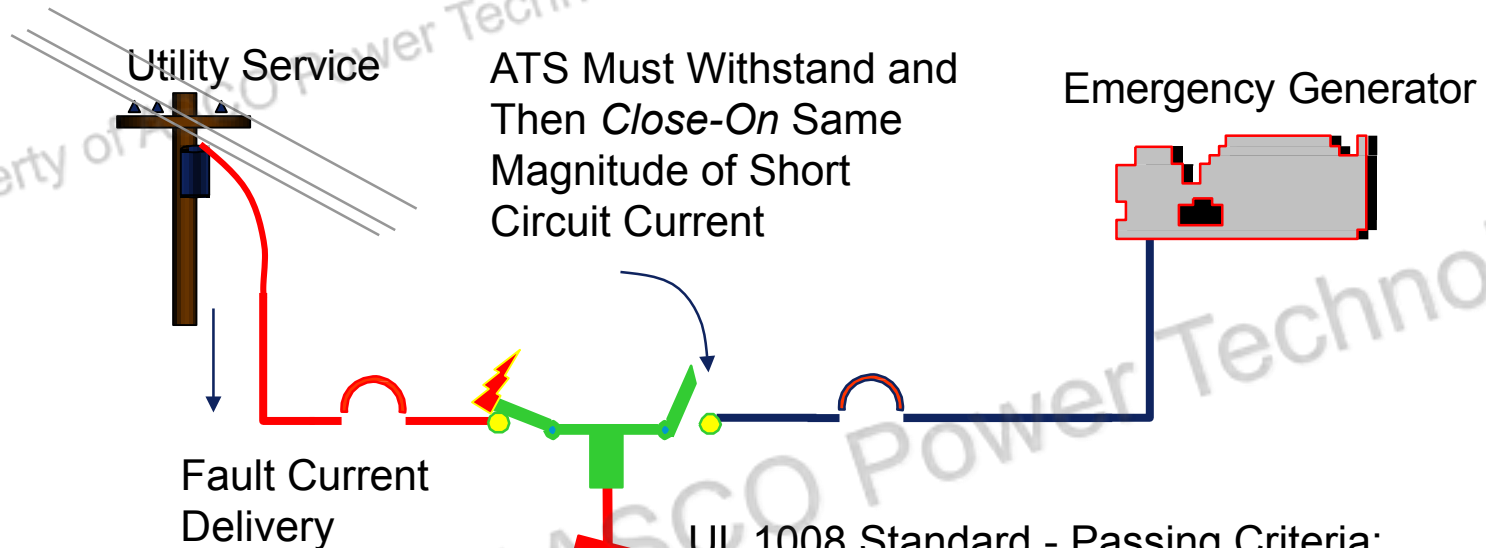

UL 1008 Standard - Passing Criteria:

- Alternate Source Main Contacts Must Exhibit Continuity After Test
- Enclosure Door Must Remain Closed
- Phase-to-Enclosure Fuse Must Be Intact
- ATS Must be Operable by Intended Means
- No Breakage of Switch Base...
- Power Cables Can't Pull Free of Terminal Lugs

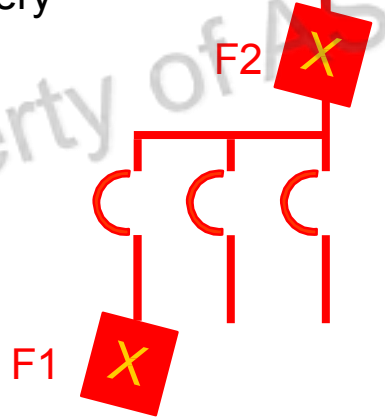

Transfer Switch Ratings

Basic Electrical Ratings

- Number of Poles: 2,3,4 Pole
- Voltage Ratings
 - Low Voltage - 120 to 600 Volts AC, 250 VDC
 - 50 or 60Hz
 - Medium Voltage Transfer Switches - 5 to 15 KV
- Current Rating: 30-4000 Amp

Current Ratings

- Continuous
- Inrush
- Overload
- Tungsten Load
- Withstand and Close-On Rating

Requirements

- Must carry current 24 hours/day
- In both normal or emergency positions
- 7 days/week for 20-40 years
- NO overheating of contacts

Automatic Transfer Switches : Physical Elements

Transfer Panel (TS)

- TS Panel / Contactor
 - Solenoid Operator
 - Motor Mechanism(s)
- Main & Arcing Contacts
- Control and Auxiliary Contacts
- Power Connections
 - Mechanical Lugs
 - Bus Stab/ Bar



Controller

- Source Monitoring
- Time Delays
- Annunciation & Controls
- Transfer Control

Over 90% of ATSs are supplied in enclosures by manufacturer, also mounted in switchboards & motor control centers.

Transfer Panel Major Components

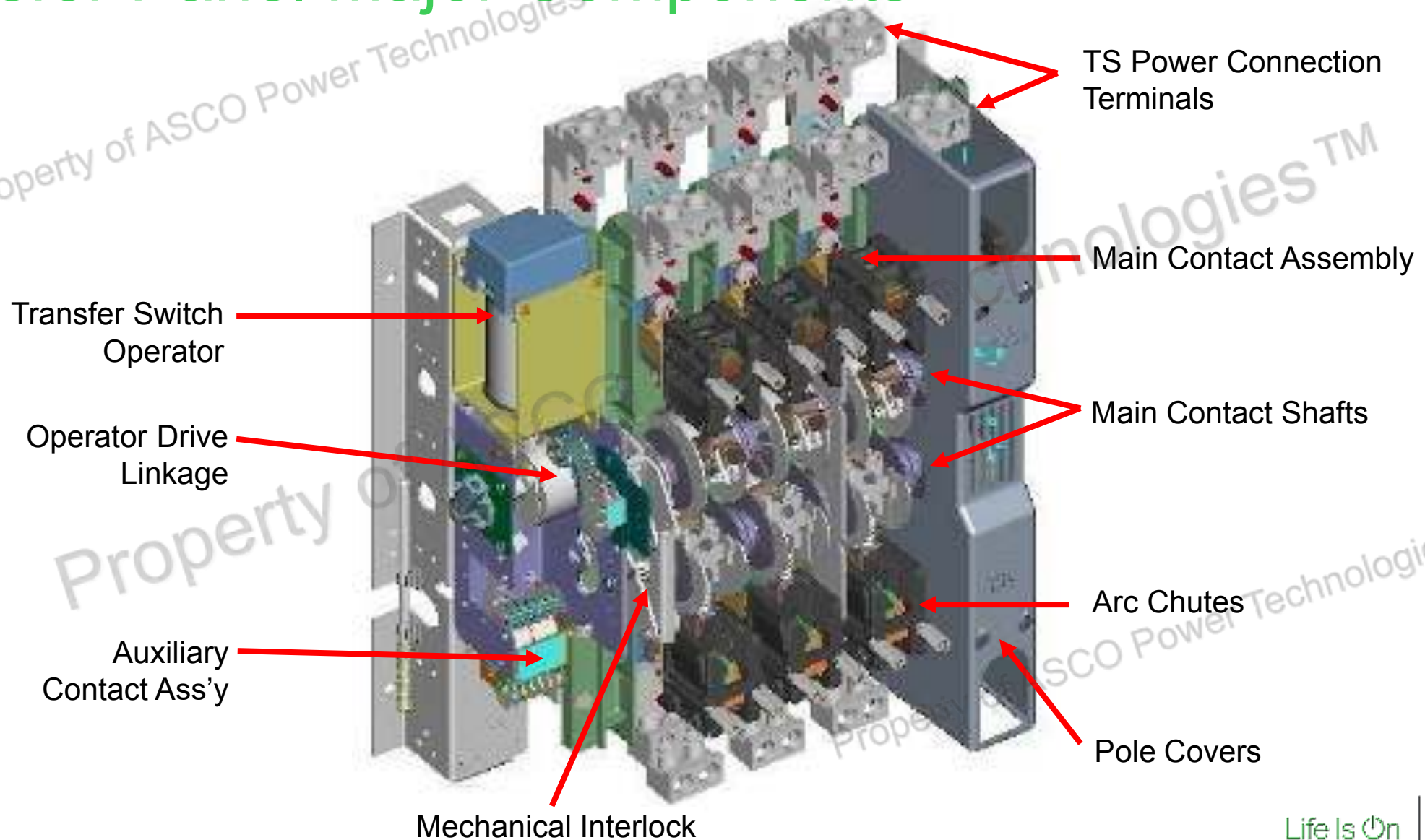

Transfer Switch Design Criteria

Designing High Reliability Transfer Switches

- Designed for Transfer Applications Between Two Live Sources
- Main Contact Structure & Material Design
- Arc Isolation & Suppression
- TS Operating Mechanism
- Neutral Conductor Switching Design

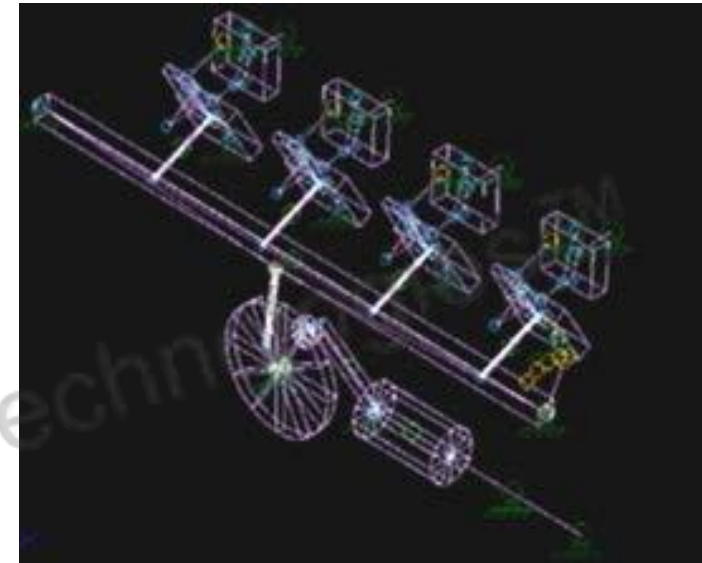

Main And Arcing Contact Path Of Motion

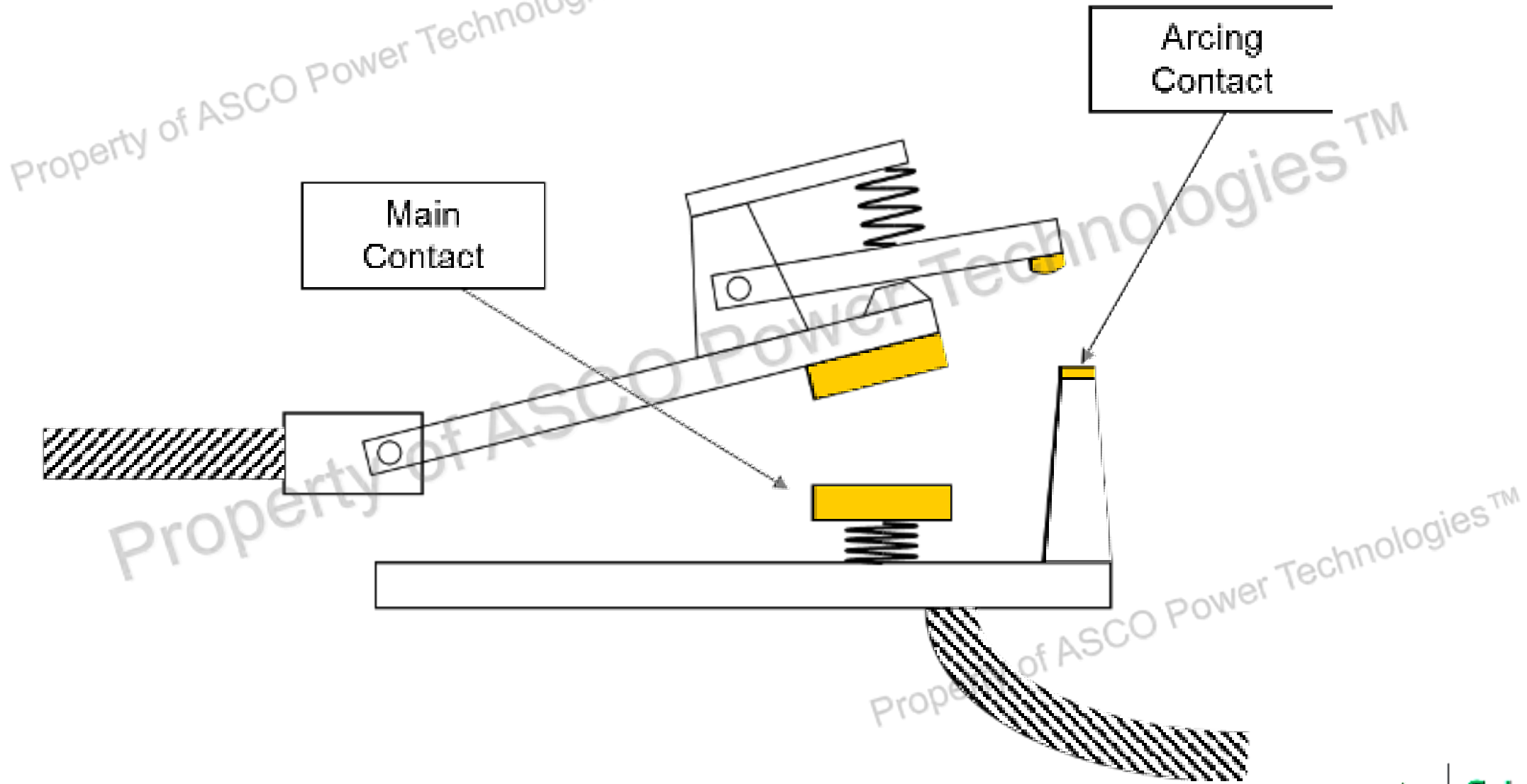

Main And Arcing Contact Path Of Motion

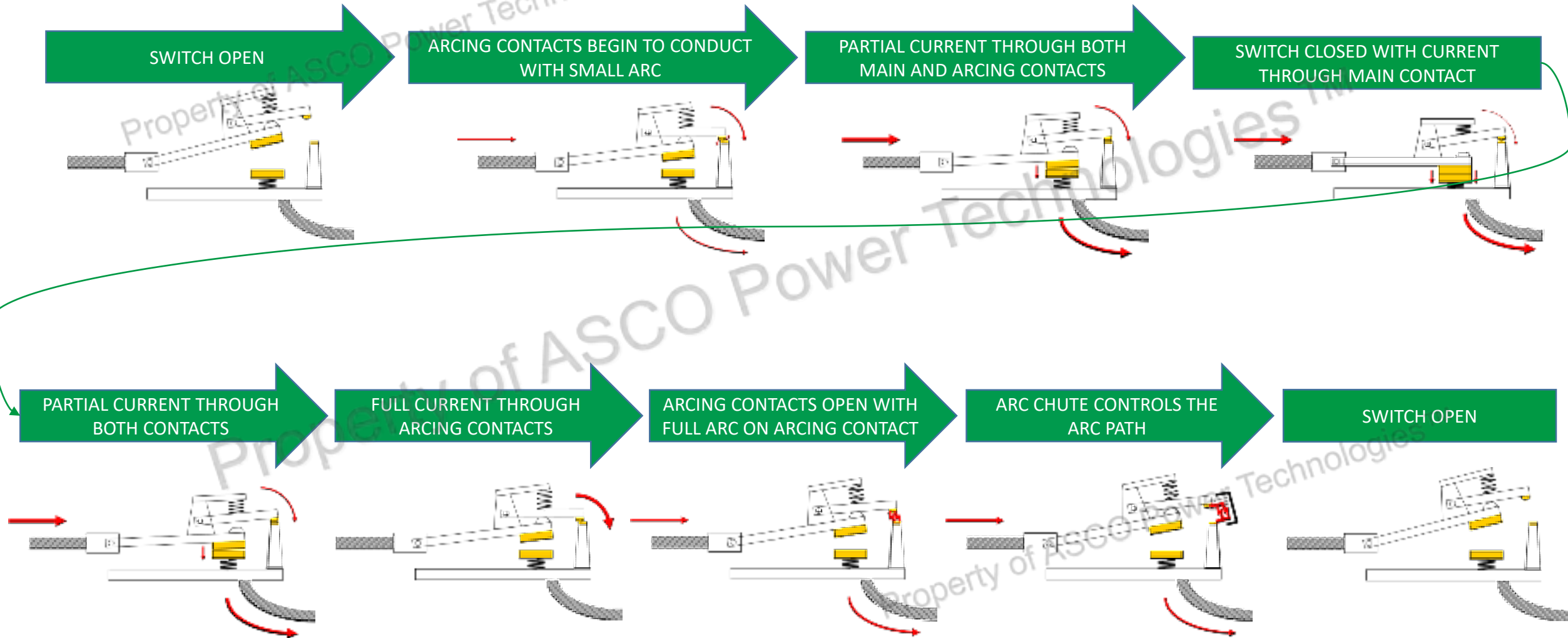

Solenoid Operator Path Of Motion

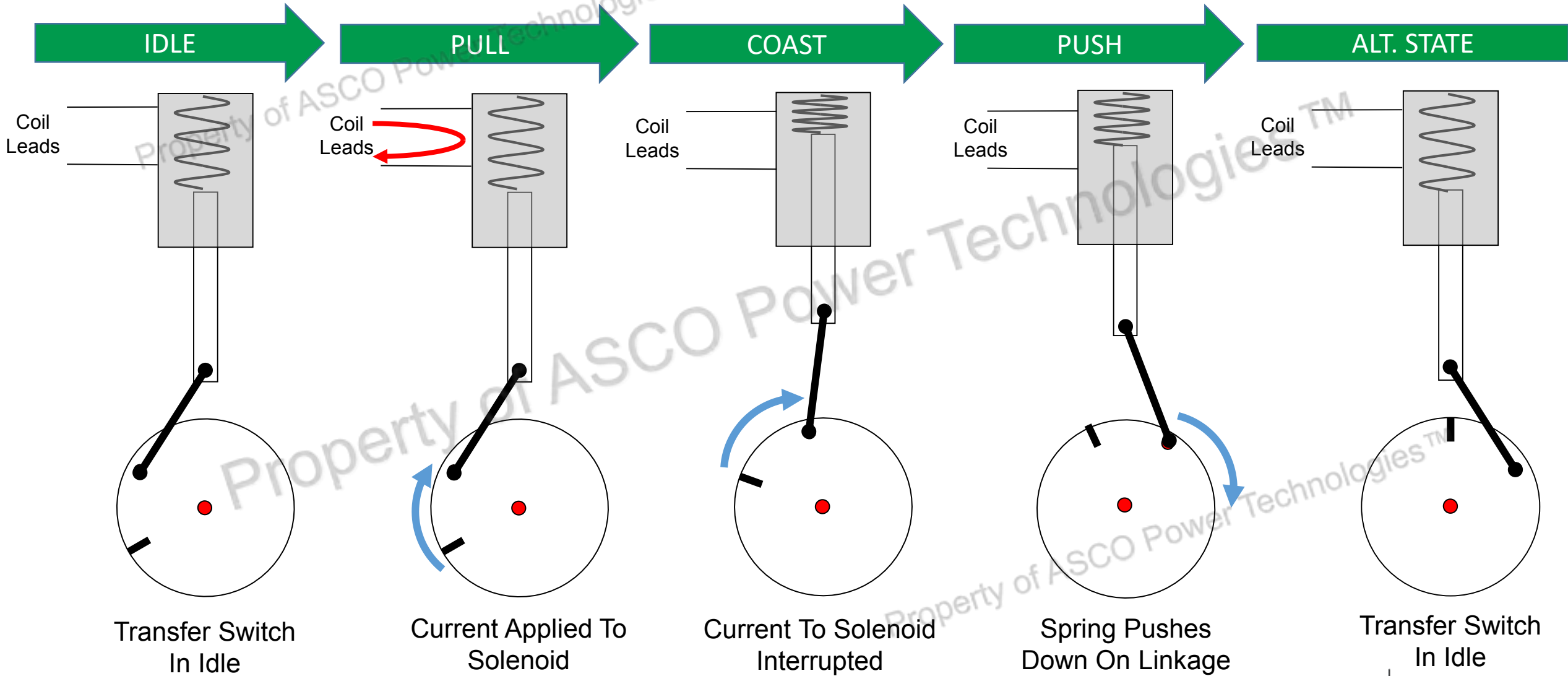

Transfer Switch Design Criteria

Design Considerations

- Carry current without over heating
- Low resistance, soft material (more silver)

Main Contact Design

- Mechanical Pressure on Main Contacts
- Segmented Contacts [vs. solid]
- Easy to Inspect and Maintain

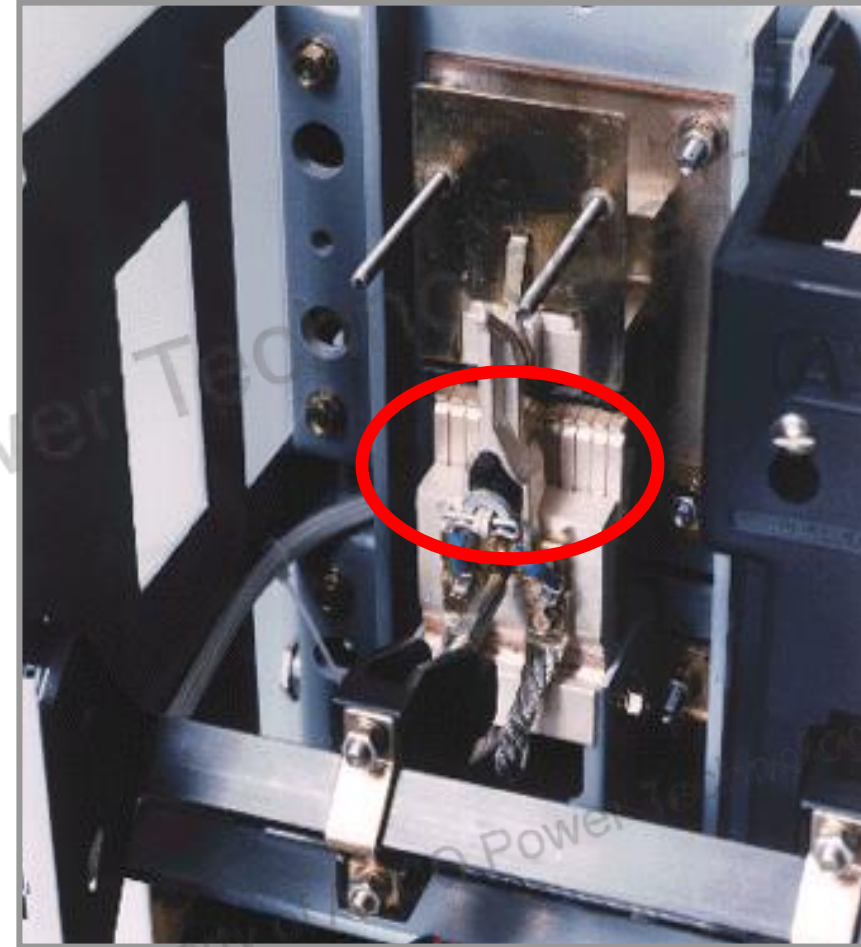

Transfer Switch Design Criteria

Design Considerations

- Carry and extinguish arcing
- Harder material (more tungsten) to sustain heat from arcing and minimize contact erosion

Arcing Contact Design

- Designed for Transfer Switch Applications
- Arcing Contact Material
- Easy to Inspect and Maintain

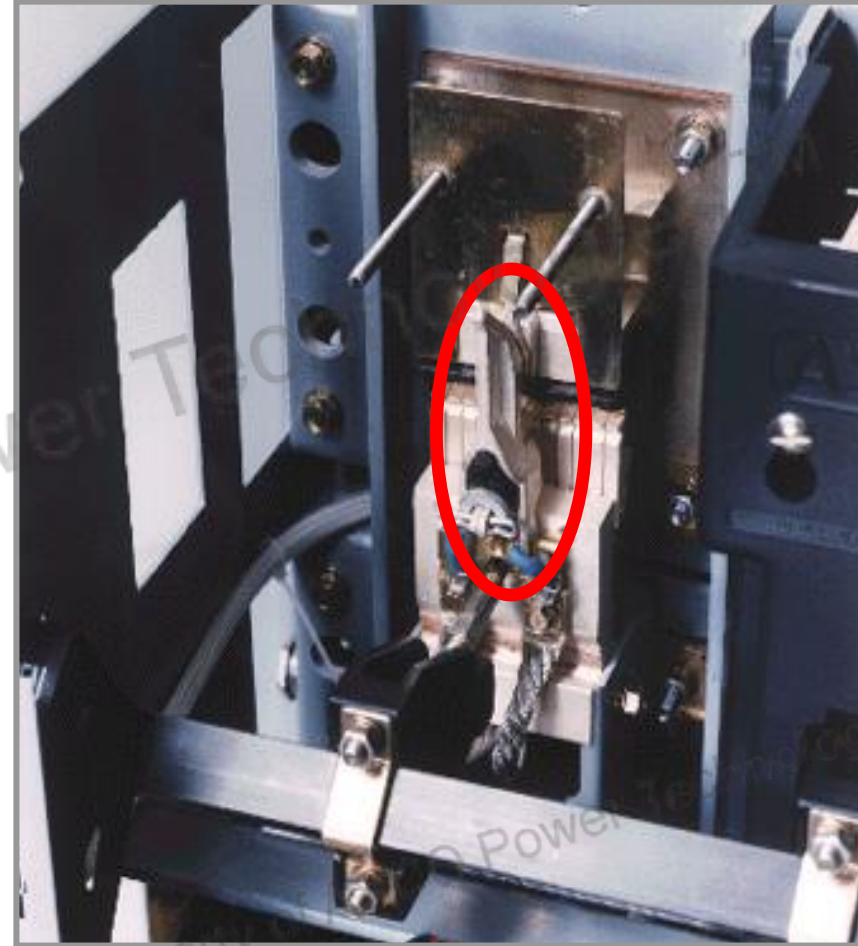

Transfer Switch Design Criteria

Effective Arc Suppression Considerations

- Must Extinguish the Arc Prior to Connection of the Opposite Source
- Separate Arcing Contacts or Arcing Tips
- Speed of Operation
- Arcing Chutes
- Wide Arc Gaps



Independent 3rd Party Study

- 10 Years Of Service Records Reviewed
- > 200 Million Operating Hours In Field
- Weibull Distribution Plots Confirmed Validity Of Data/MTBF
- Average MTBF = 1.4 Million Hours = ~159 Years
- 5 – 9's Of Availability
- Ultra Conservative Process Used

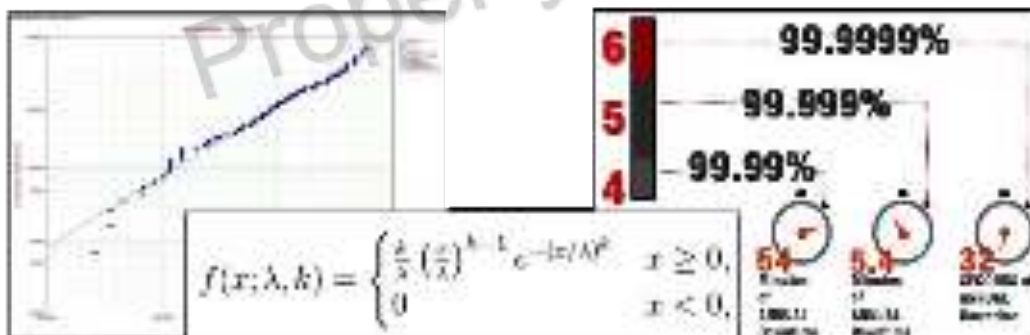

Determining Reliability of Low Voltage Transfer Switches [2016-PSEC-0039]

Robert Arco, Harris Information Systems, 2016 IEEE
 Mark D'Amico, Harris Information Systems
 Alvin Trivette, ASCO Power Technologies, IEEE Member
 Joseph Winters, P.E., ASCO Power Technologies, IEEE Life Member

IEEE	GOLD BOOK	THIS STUDY
MTBF	171,197	1,412,450
Failures/Year	0.05117	0.006
Availability	99.997605%	99.9997998%
Annual Downtime	15minutes, 46 seconds	63 seconds

3-Pole vs 4-Pole (Single Ground Path)

A Typical 3-phase, 4-wire ATS Installation Can Be Comprised Of A 3-pole ATS With Solid Neutral And A Single Path To Ground In The System.

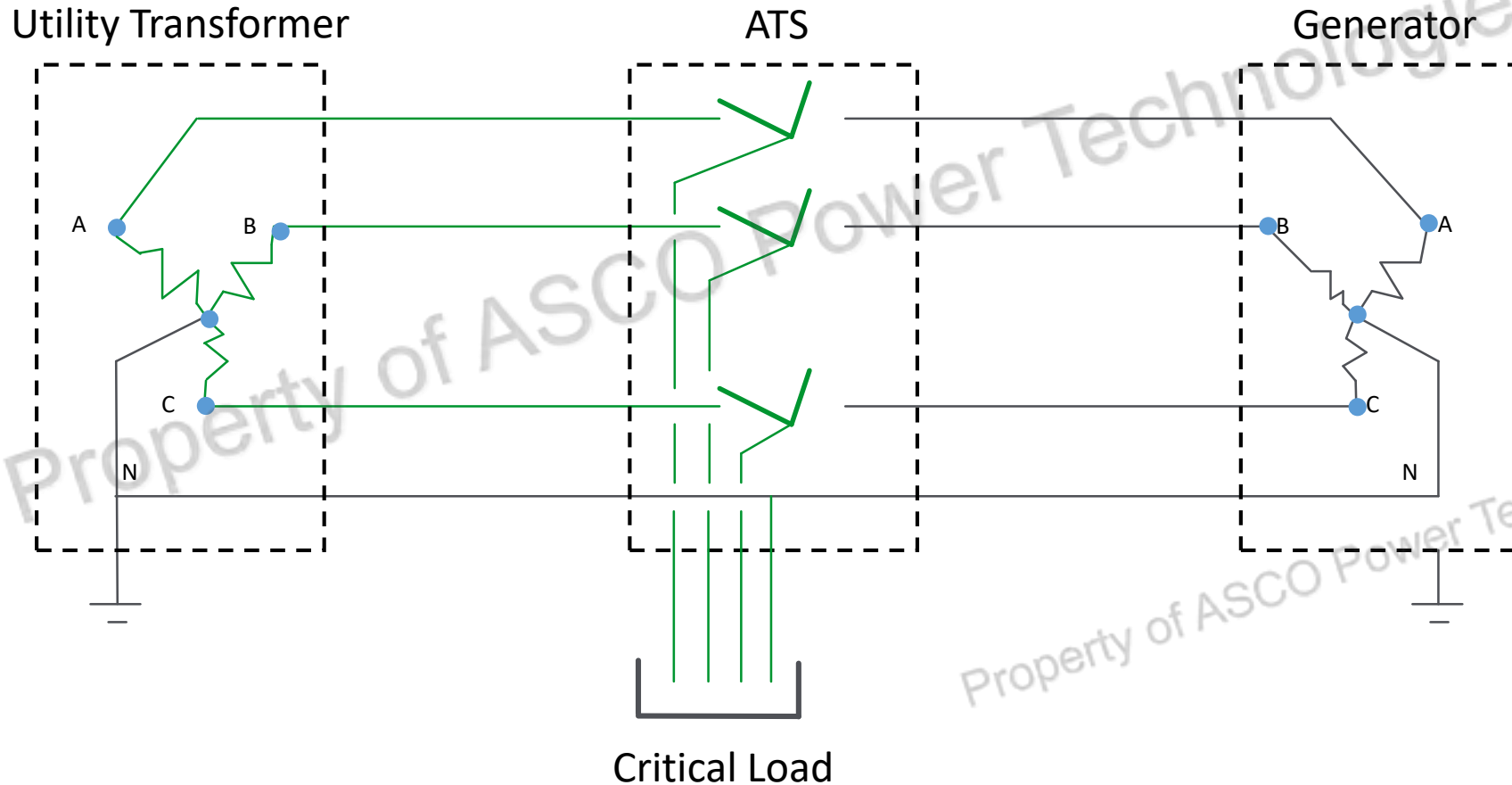

3-Pole vs 4-Pole (Single Ground Path)

A Normal Side Cable Failure Can Result In An Ungrounded System.

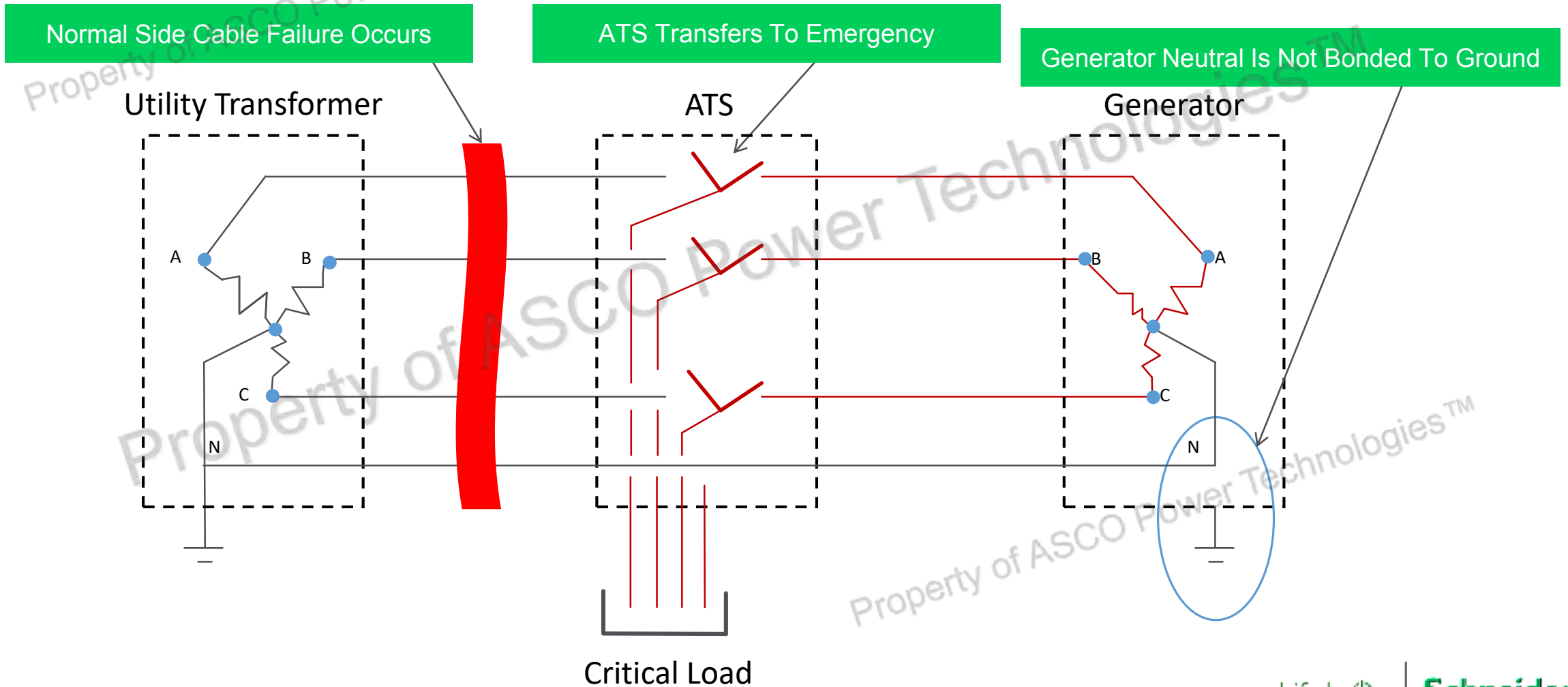

3-Pole vs 4-Pole (Two Ground Paths)

This Example Shows A 3-phase, 4-wire System With Both the Neutral Of the Utility Transformer And the Generator Bonded To Ground.

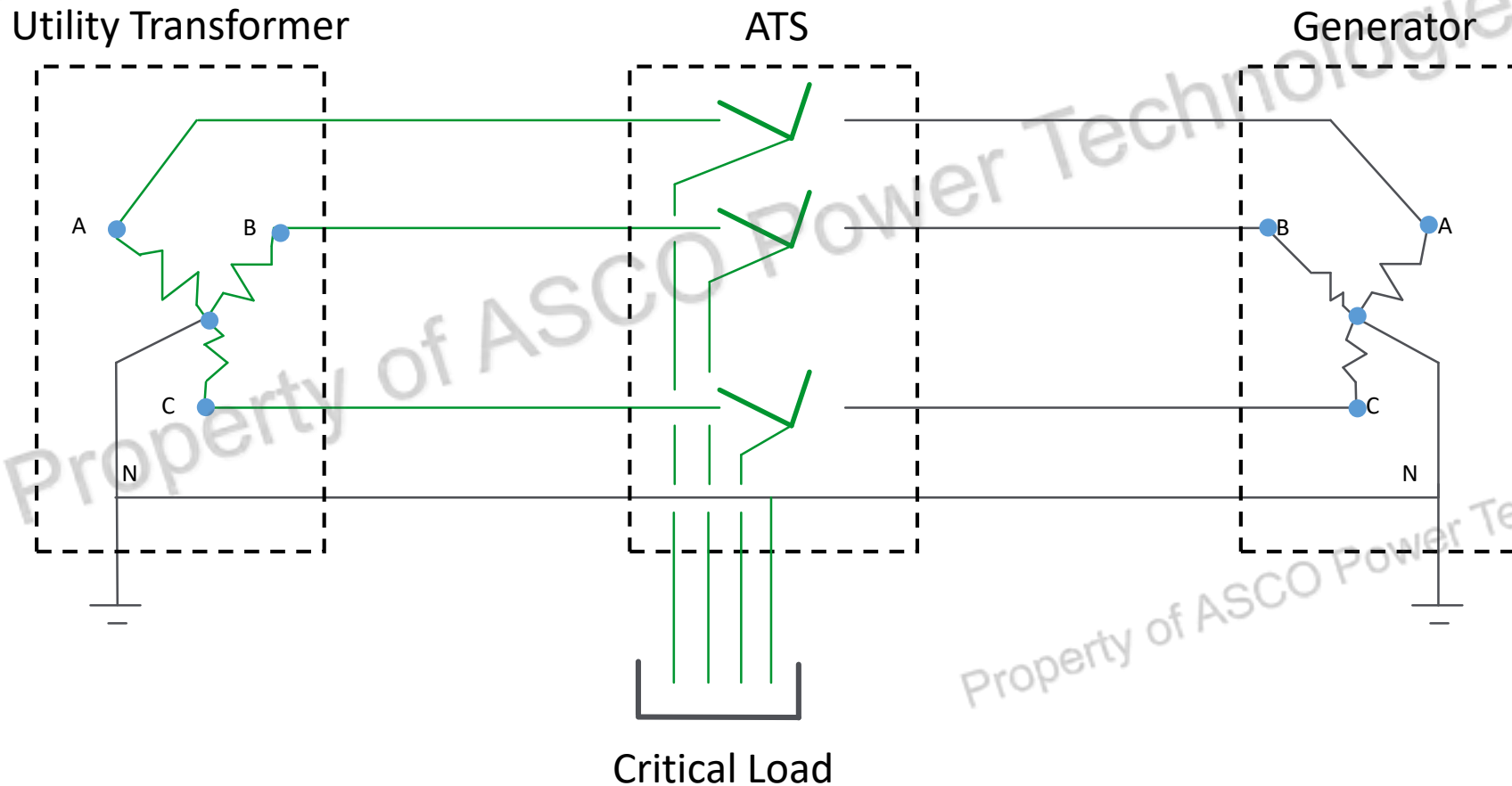

3-Pole vs 4-Pole (Two Ground Paths)

If A Ground Fault Occurs, Two Paths Exist For Carrying The Ground Fault To The Source.

Current Traveling In The Correct Path For Zero Sequence Sensing

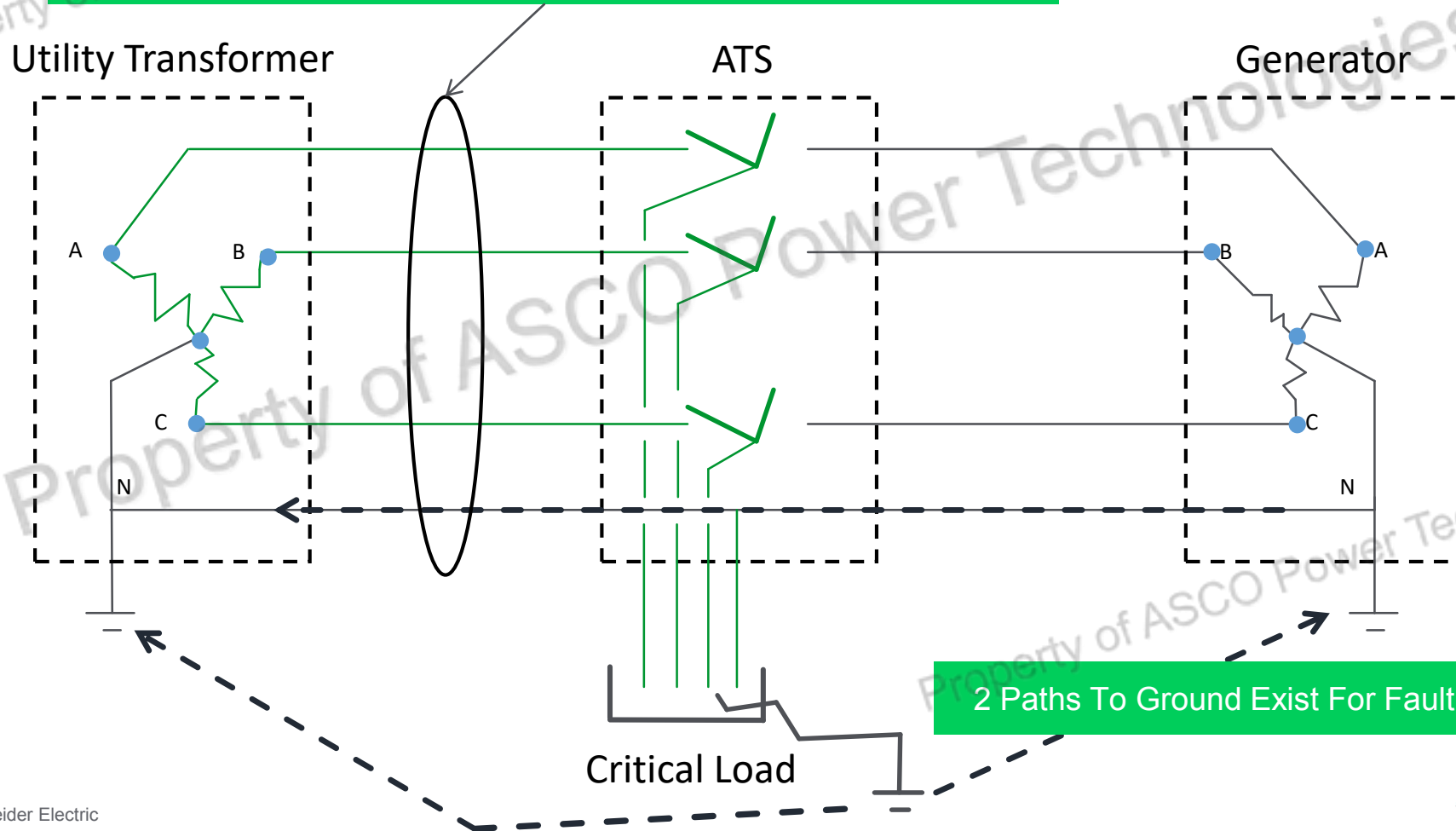

4-Pole ATS Deployment

This Example Shows A 3-phase, 4-wire System With Both the Neutral Of the Utility Transformer And the Generator Bonded To Ground And a 4-pole ATS.

Switching The 4th Pole Provides Neutral Isolation And Proper Ground Fault Sensing In The Event Of A Ground Fault

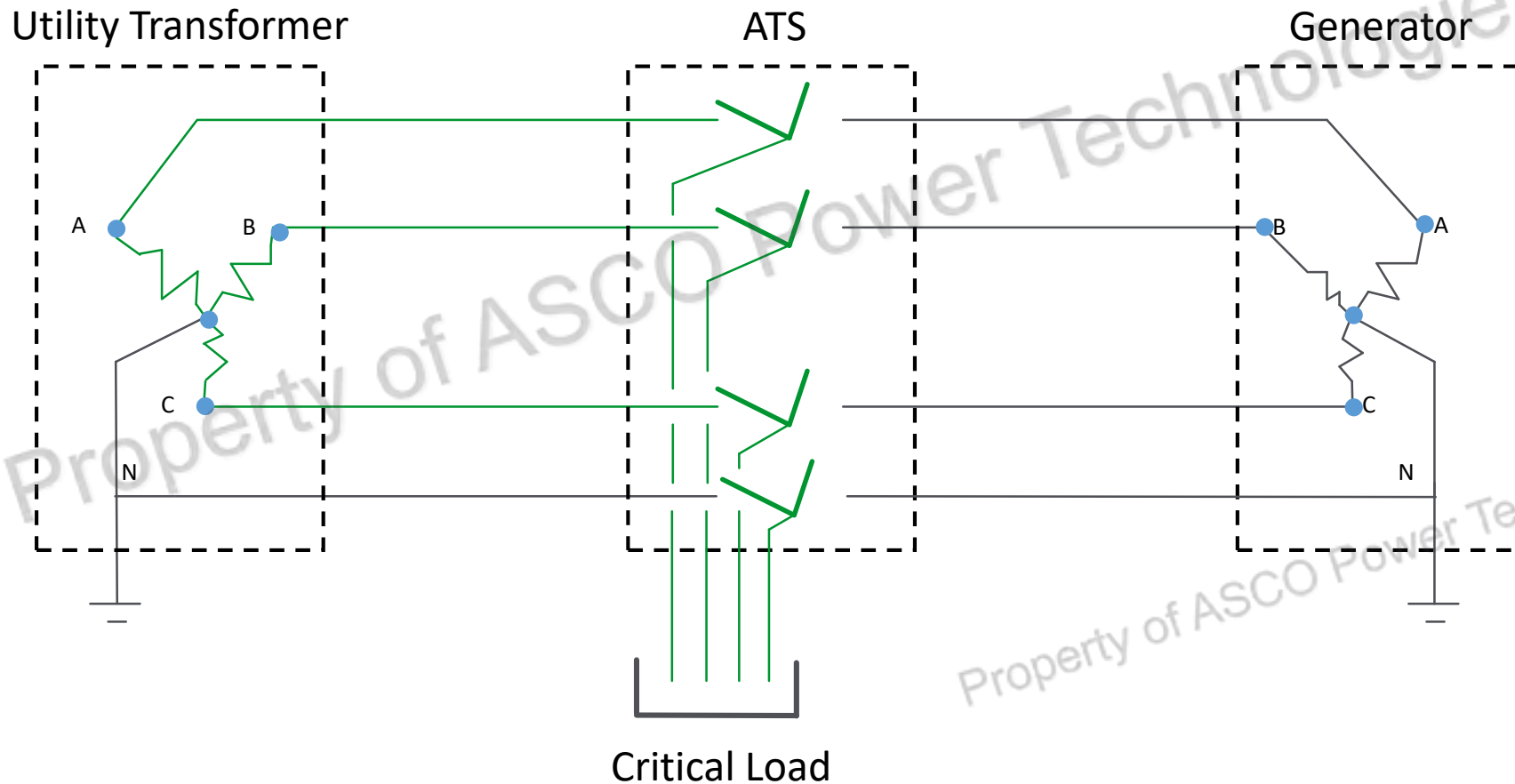

Sensing and Measurement

- Core ATS controls are driven based on two parameters.
 - Voltage
 - Frequency
- All other parameters are derived based on these readings.
 - Phase Angle
 - Voltage Unbalance
 - Phase Rotation
- Some systems may add current sensing to allow for more advanced features.
- Although sensing happens at sub cycle levels all information is presented in RMS format.
- Most controllers accept LV range up to 600Vac but can support higher voltages via Potential Transformers. (ex. Medium voltage transfer switches)

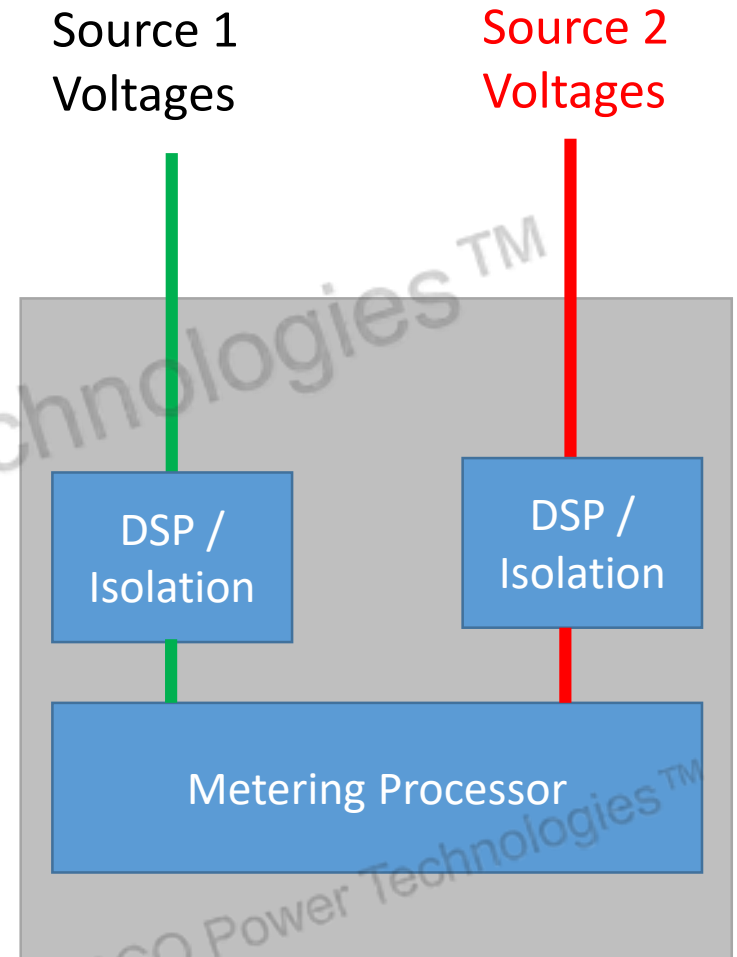

Source Health & Acceptability

- The acceptability of a source is determined by comparing the Realtime voltage & frequency to pre-defined levels.
 - Under/Over Voltage - to ensure voltage is at safe levels. Not limited to blackout conditions but also brown outs.
 - Under/Over Frequency – to ensure frequency is at proper levels. Usually more relevant on Generator sources where overload may result in frequency drop.
 - Voltage Unbalance – useful in detecting transformer issues or single phasing situations.
 - Phase Rotation- to ensure phases are wired in the proper order especially on portable generator installations. (ABC/CBA)
- Most parameters depend on pickup and dropout settings.
- These levels can be user configurable or hard coded.
- Exact acceptability requirements may change based on loads or geographic characteristics.

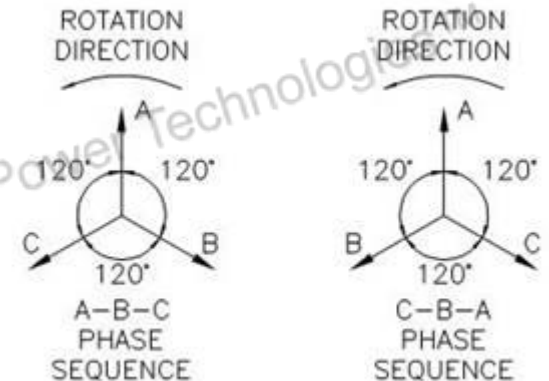

Pickups & Dropouts

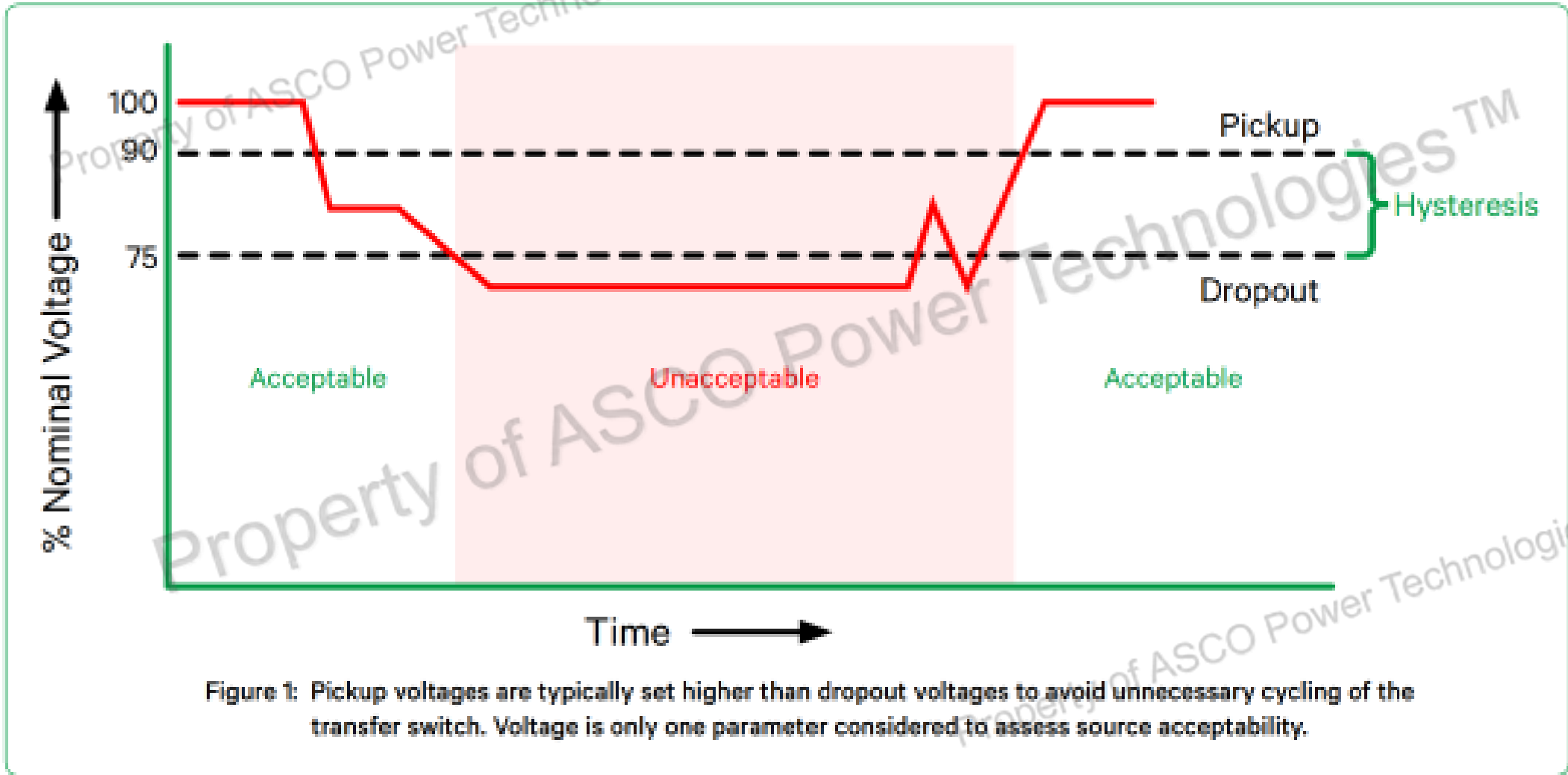

Figure 1: Pickup voltages are typically set higher than dropout voltages to avoid unnecessary cycling of the transfer switch. Voltage is only one parameter considered to assess source acceptability.

Common Time Delays

Time Delay

Typical Duration

Source Failure Delay

- Begins when the primary source becomes unacceptable.
- Used to override momentary source transients and prevent nuisance gen starts.
- Gives time for protection devices to clear faults.
- Issues engine start signal when complete. (duration limited by controller power supply)

~3s

ENGINE START ACTIVATED

S1 to S2 Transfer Delay

- Begins once generator power becomes acceptable.
- Gives generator time to stabilize.
- Allows user to stagger transfers of multiple transfer switches.
- When complete the transfer sequence is initiated.

~5s-30s

TRANSFER TO S2

S2 to S1 Transfer Delay

- Begins once S1 is becomes acceptable or test signal is removed.
- Gives time to ensure that source has returned for good.
- Allows user to stagger transfer of multiple transfer switches.
- When complete transfer sequence is initiated.
- Various sub timers exist to allow for differing delays based upon condition that caused the initial transfer.

~5m - 30m

RETRANSFER TO S1

Engine Cooldown

- Begins once switch has returned to S1.
- Keeps engine start signal active while running to allow for engine to cooldown prior to shutdown.
- When complete deactivates engine start signal.
- Sometimes can have multiple settings based on if it was a tru

~10m - 15m

ENGINE START DEACTIVATED

Usually set to 0 for life safety loads to time to power

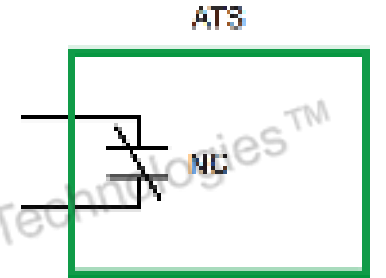

Engine Start signal is a 2 wire signal driven from a relay that deenergizes when the generator is needed.

Transfer Switch Types-Transitions

Automatic Transfer Switches use differing sequences to optimize switching events according to application.



Open Transition (Break-before-make)

- Most common transition mode.
- Only requirement is that there be acceptable power on destination source.
- Results in momentary (<80ms) loss of power while contacts are moving. May result in some electronics to shut off.
- Can optionally be done “in-phase” between the sources when performing hot-to-hot transfer.

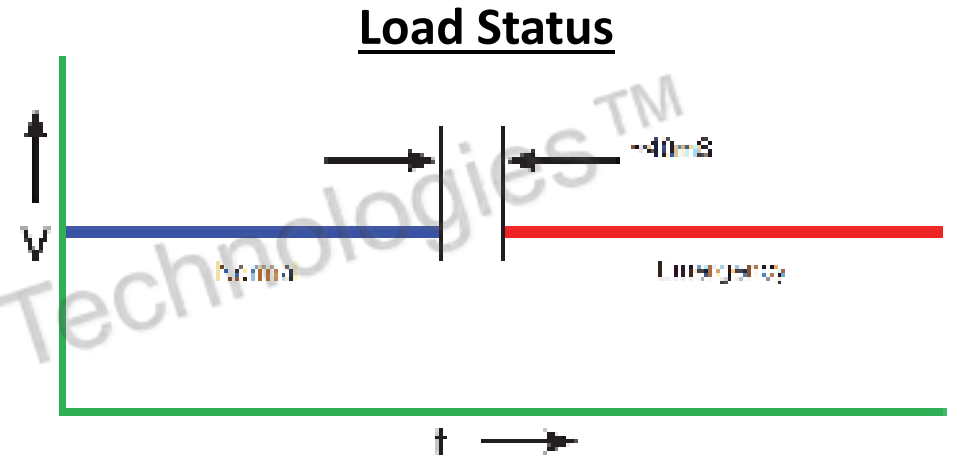

Before Transfer

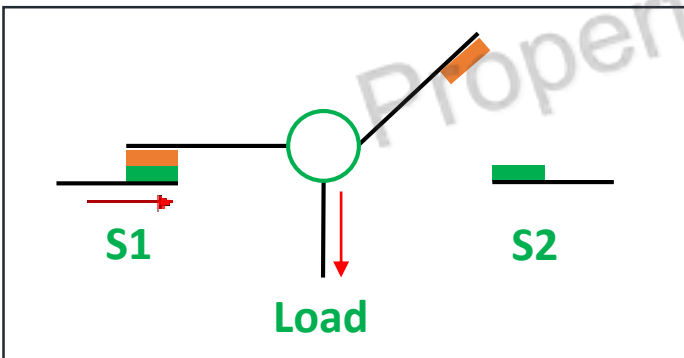

During Transfer

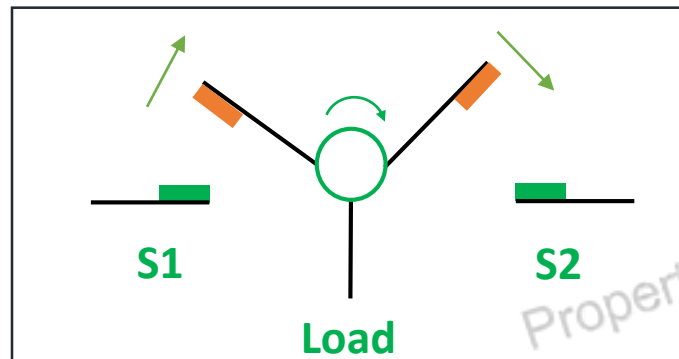

After Transfer

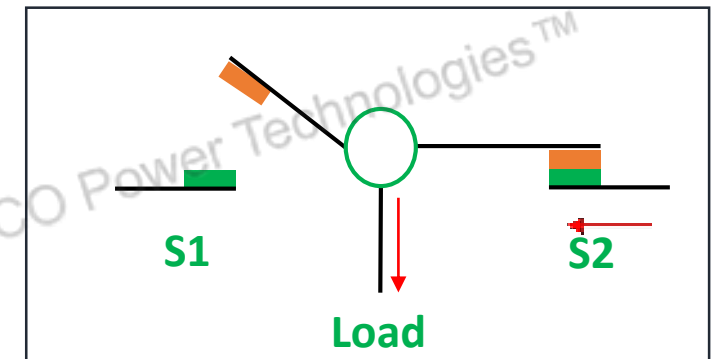

In-Phase Transfer

- During hot-to-hot transfers motors may be stressed due to a rapid shift in phase angle between the two sources.
- In-phase transfer passively monitors the phase angle difference between the sources and transfers when they are within a “in-phase” window.
- This adds a variable delay in the transfer sequence while the system waits for in-phase to occur.
- Usually generators frequencies are set slightly (0.1Hz) higher than utility to ensure natural drift.
- Recommended only for open transition systems due to quick transfer operation requirement.

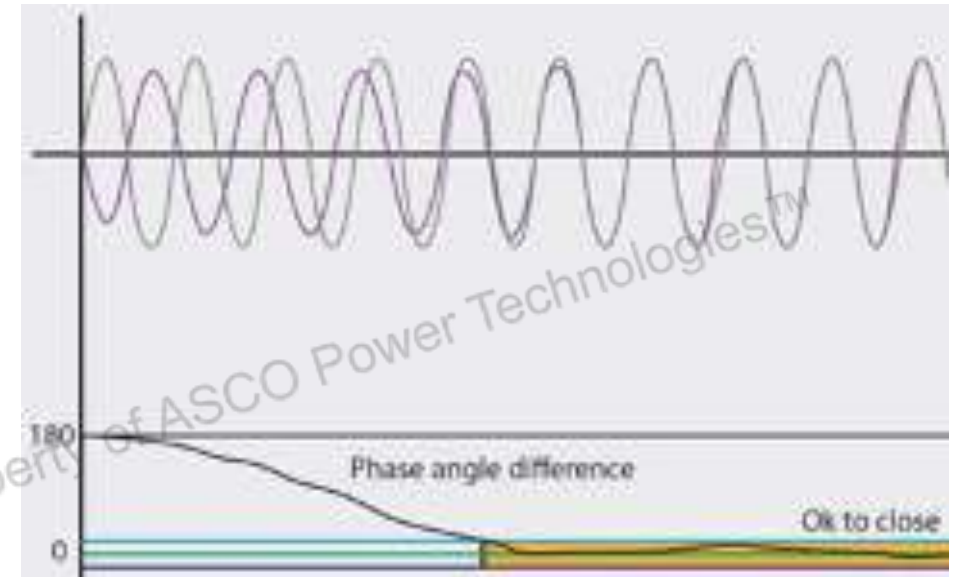
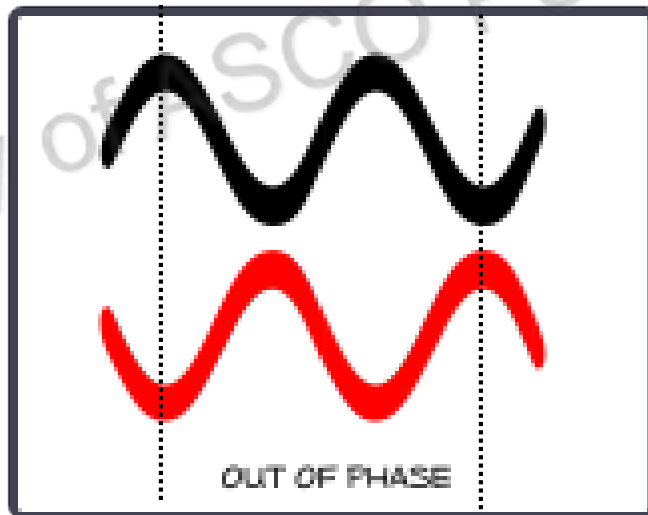
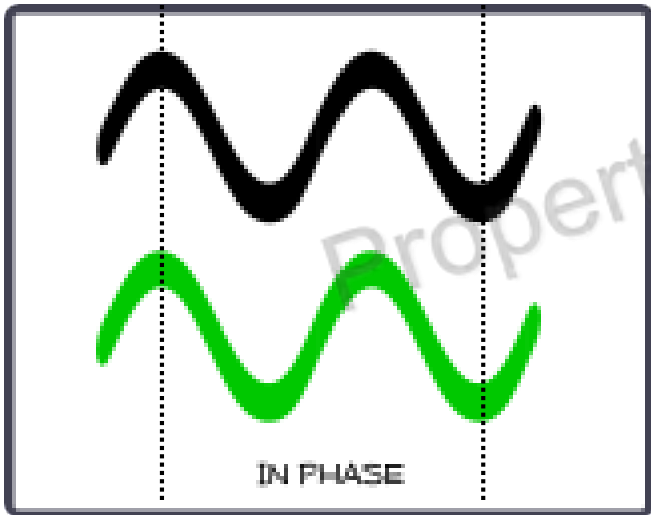

Delayed / Programmed Transition (Break-before-make)

- Provides extended duration of disconnect time before reconnecting.
- Disconnect period allows motor loads to wind down and transformers dissipate residual voltages.
- Only requirement is acceptable power on S2 and independent operators.

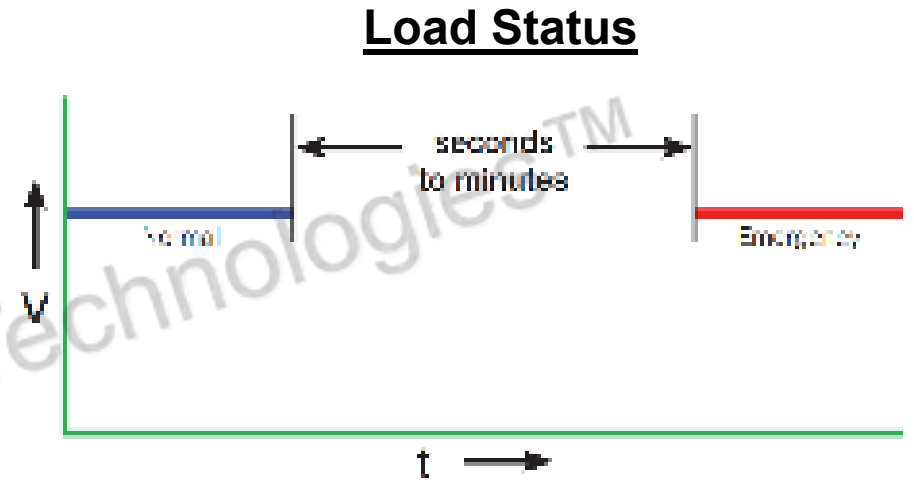

Before Transfer

Disconnect S1

Wait...

Connect S2

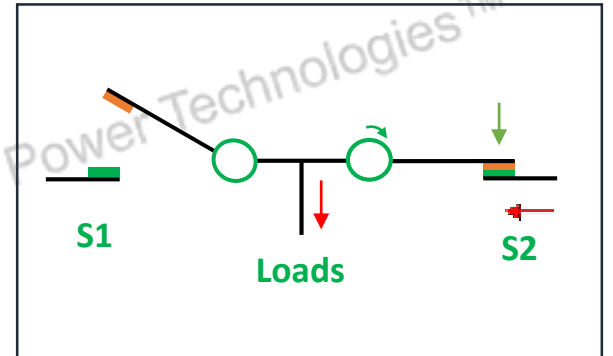
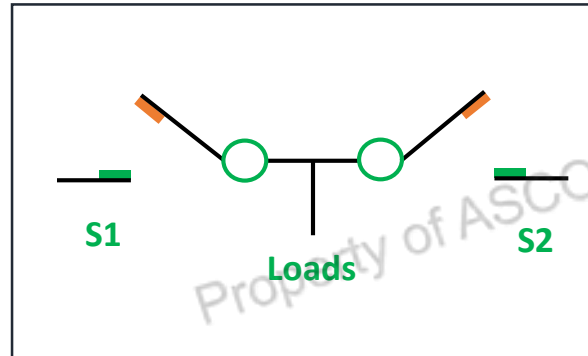
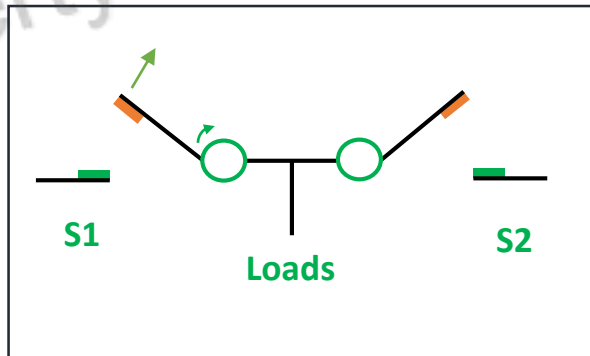
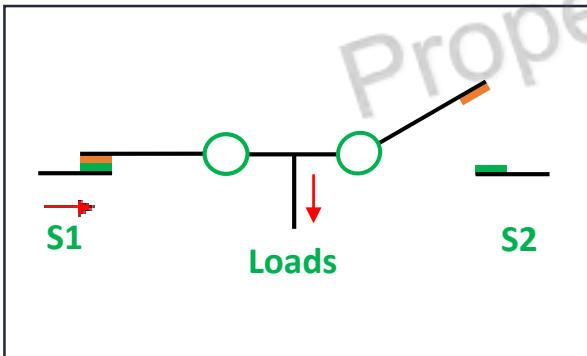

Closed Transition (Make-before-break)

- Provides momentary parallel during to prevent any interruptions to loads.
- Convenient for periodic system testing or retransfer events with minimal load impact.
- Should include multiple recovery modes in response to stalled transfer.
 - If S1 fails to disconnect, then go back and disconnect S2 to end parallel..
 - If parallel goes beyond 100ms send shunt trip to upstream breaker.

Load Status

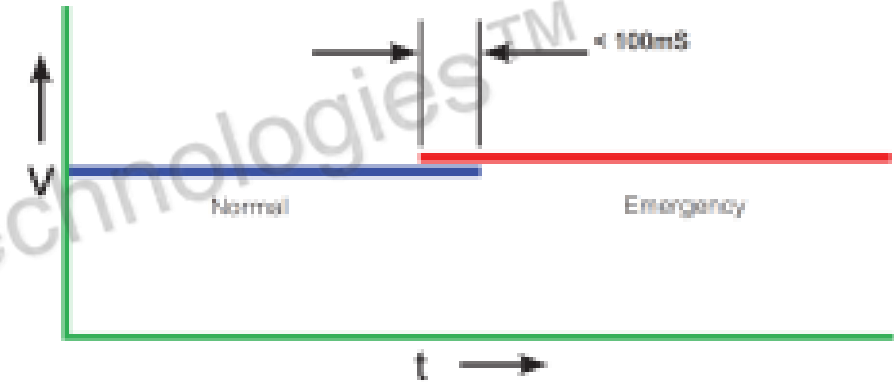

Before Transfer

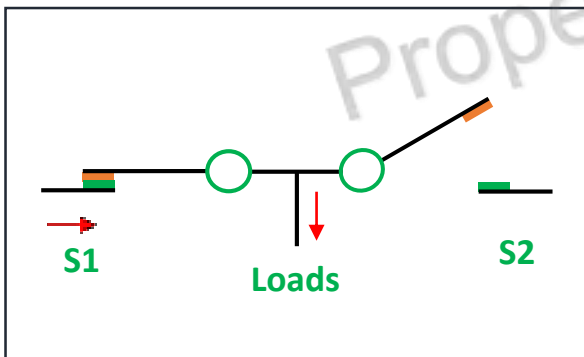

Connect S2

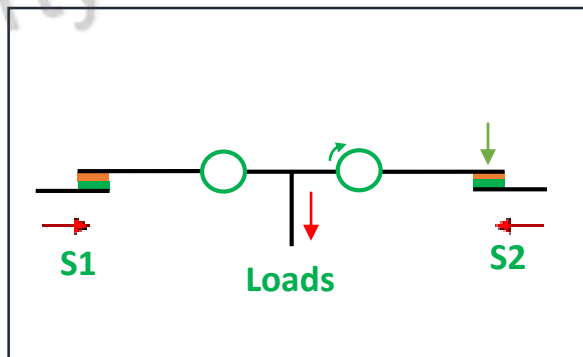

Parallel <100ms

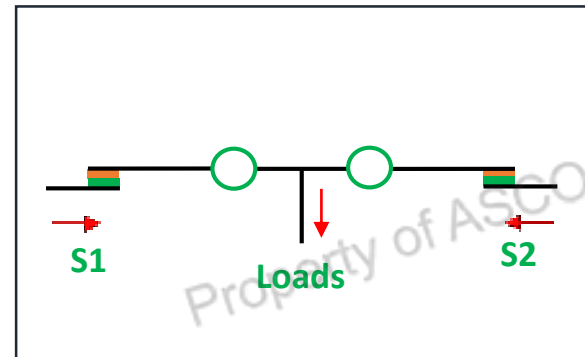

Disconnect S1

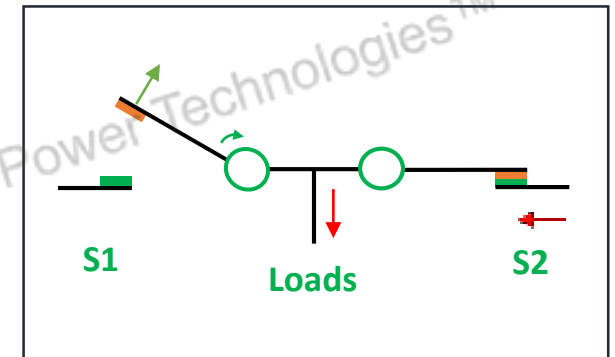

Closed Transition (cont'd)

- Closed Transition (Make-before-break)

- To avoid mechanical shocks, large transients, reverse power flow, and large in-rush currents many parameters must be met before Closed Transition Transfer can occur...
 - Both sources must be acceptable.
 - Frequency difference must be $<0.2\text{Hz}$
 - Voltages must be within 5% of each other.
 - Phase angle difference must be <5 degrees. (will passively monitor phase angle relationship)
- This adds a variable in the transfer duration.
- If after a user configured duration these criteria are not met the systems can be programmed to proceed with a delayed transition transfer instead.
- Requires coordination with utility to check for any special requirements.



CONSOLIDATED EDISON COMPANY OF NEW YORK, INC.
4 IRVING PLACE
NEW YORK, NY 10003

DISTRIBUTION ENGINEERING, NETWORK SYSTEMS SECTION

SPECIFICATION EO-2104
REVISION 2
DECEMBER, 2012

CLOSED TRANSITION TRANSFER
FROM AND TO CON EDISON'S SUPPLY

FILE: APPLICATION AND DESIGN
MANUAL NO. 3

TARGET AUDIENCE	ENERGY SERVICES FIELDING OPERATIONS REGIONAL ENGINEERING DISTRIBUTION ENGINEERING
NE&C REFERENCE 2012	

Copyright Information: This document is a confidential document and its use is restricted to the intended audience. It is not to be distributed outside the intended audience. If you are not an intended audience, you should not disseminate this information. Page 10 of 11

Load Shed vs Load Management

- Load Management

- Used to signal downstream loads to turn off or disconnect to prevent overloading of a source.
- These signals are outputs from the ATS which drive...
 - Breakers to shunt trip open
 - Contactors to open
 - Equipment to turn off
- Requires of monitoring loading (current sensing/metering).
- Used in smaller systems where no power control system is present.

- Load Shedding

- Used to force a transfer switch to disconnect from a source.
 - Shedding a switch results in it going to an unacceptable source or a disconnected position.
 - When initiated load shedding bypasses all time delays.
- Load shed is an input to an ATS.
- Used by power control systems to remove a low priority ATS from an emergency bus if the gen is overloaded.
- Delayed transition switches are recommended to allow for a disconnect position rather than expose loads to unacceptable source.



Transfer Switch System Solutions

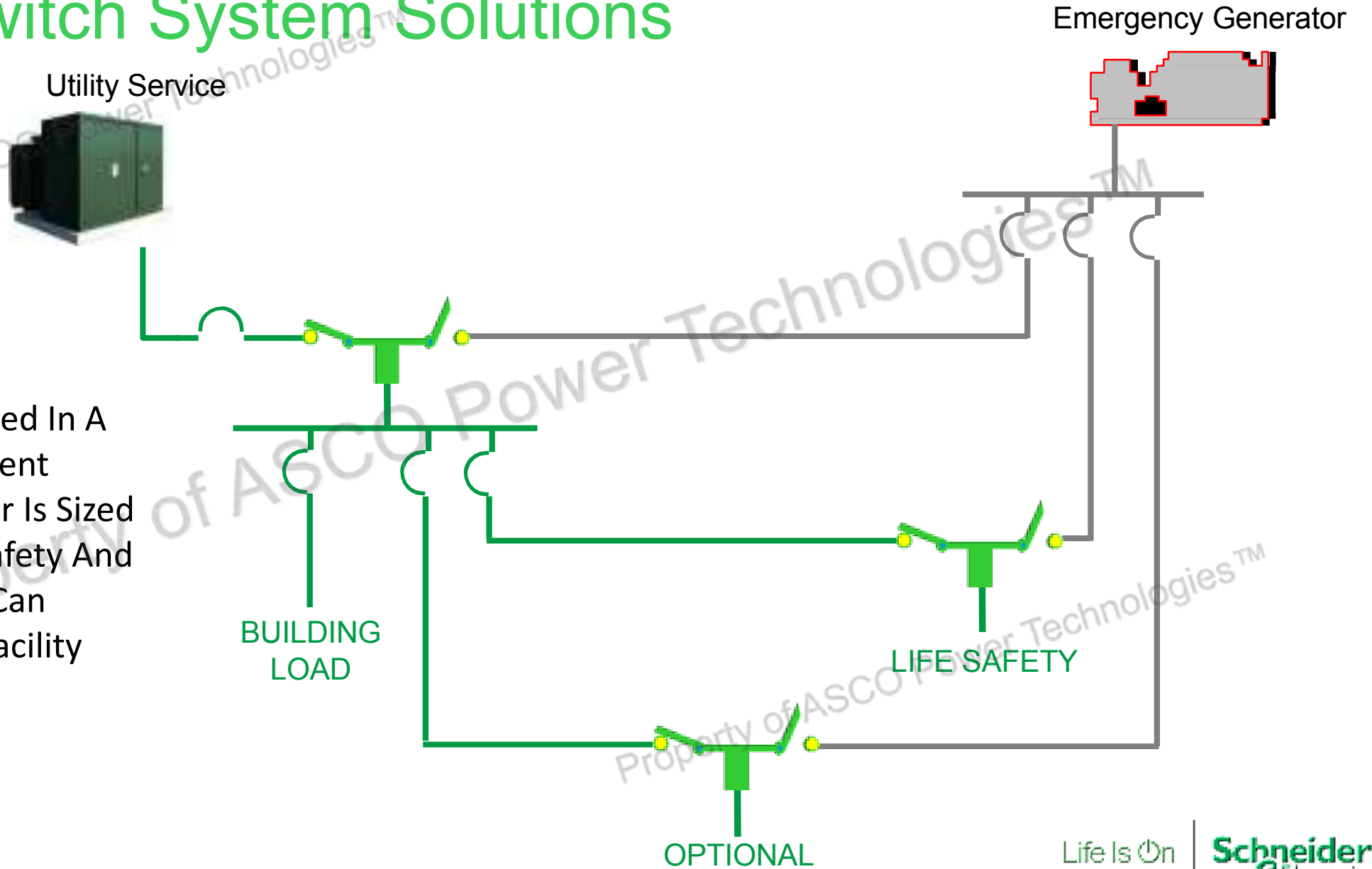

The Facility Is Deployed In A Temperate Environment Where The Generator Is Sized To Handle The Life Safety And Optional Loads And Can Support The Entire Facility 70% Of The Time.

Transfer Switch System Solutions

NO CONTROL APPLIED

Utility Service



POTENTIAL OVERLOAD

Emergency Generator

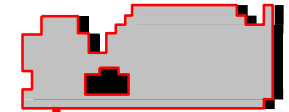

A Loss Of Utility Allows All Automatic Transfer Switches To Transfer To The Generator Source, Creating A Potential Overload.

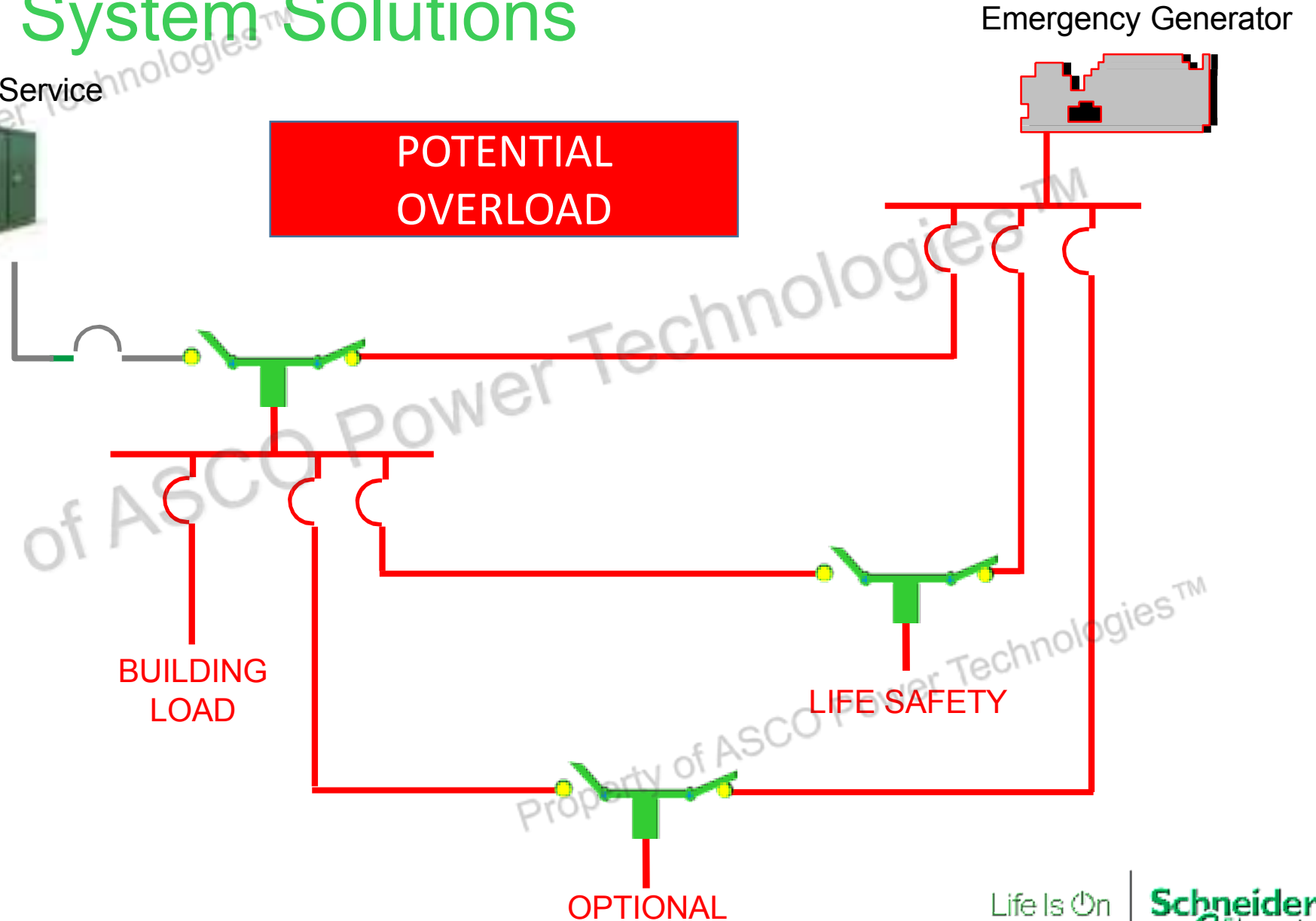

Transfer Switch System Solutions

NO CONTROL APPLIED



DOWNSTREAM ATSS RETRANSFER

Emergency Generator

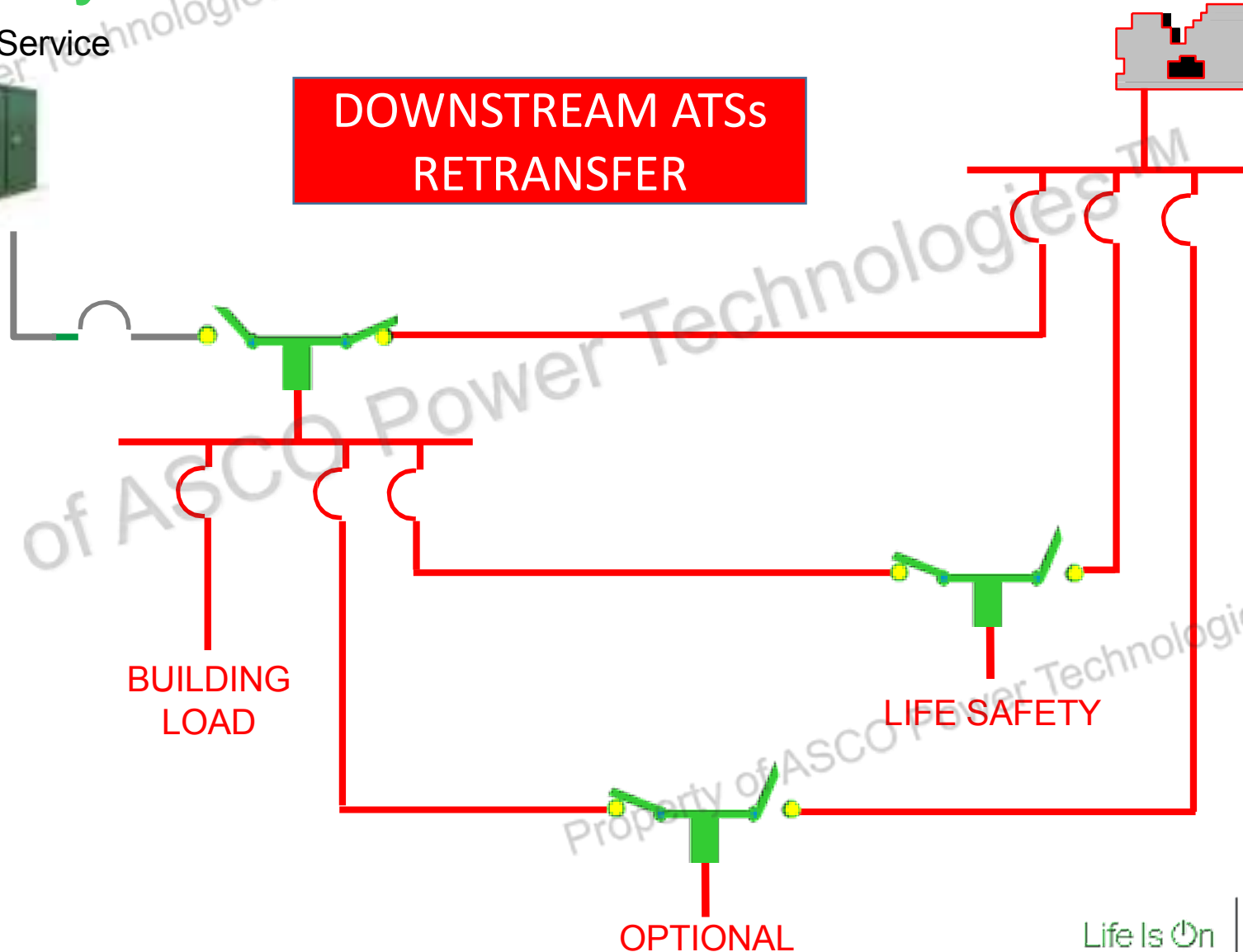
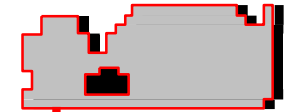

The Downstream Automatic Transfer Switches Will Retransfer To Their Primary Source Once The Service Entrance Rated Automatic Transfer Switch Transfers To The Generator Source.

Transfer Switch System Solutions

NO CONTROL APPLIED



DOWNSTREAM ATSS DE-ENERGIZE

Emergency Generator

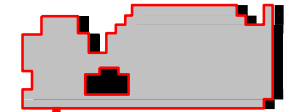

The Downstream Automatic Transfer Switches Will Experience An Additional Outage When The Service Entrance Rated Automatic Transfer Switch Retranksers To The Utility Source.

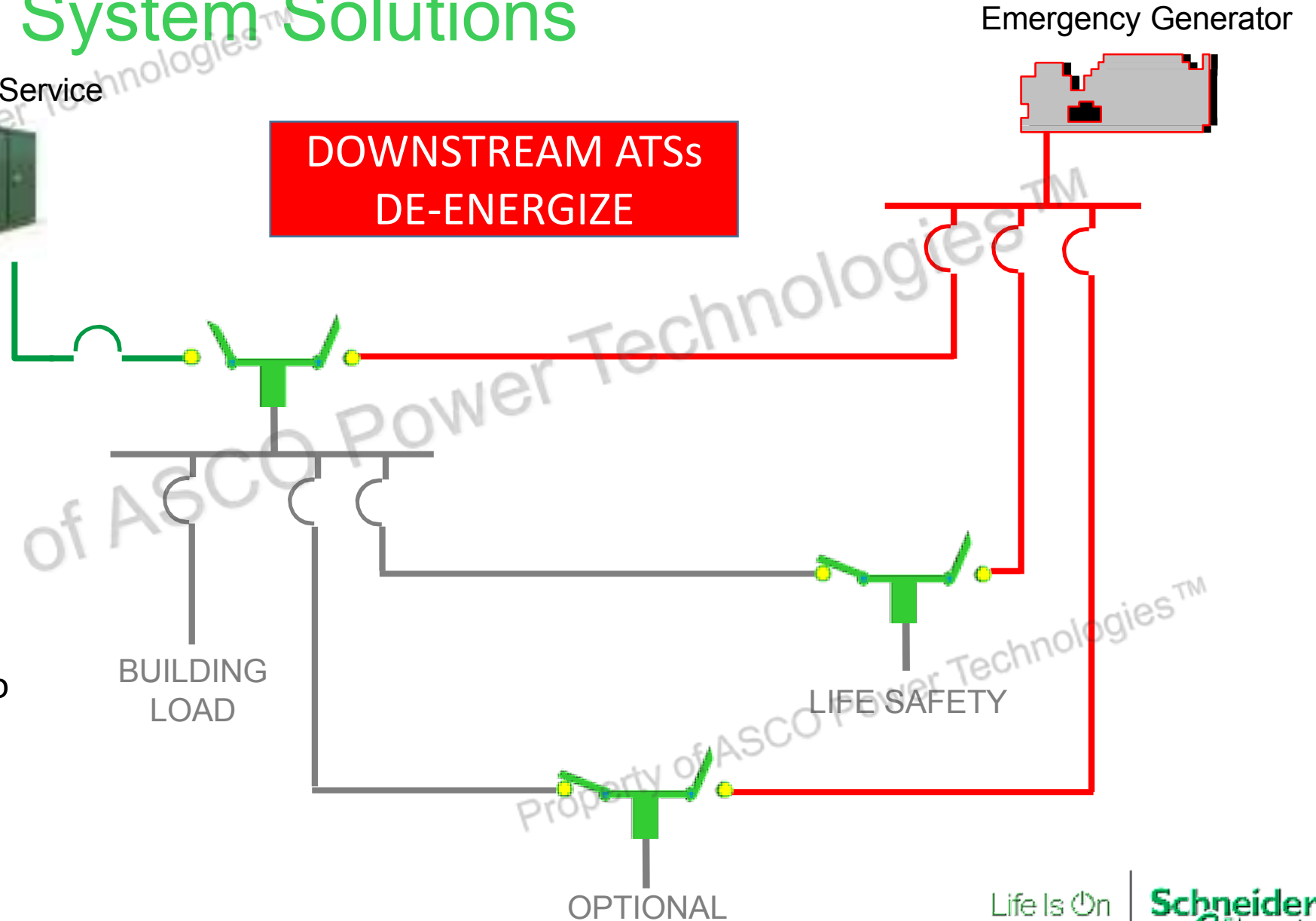

Transfer Switch System Solutions

CONTROL APPLIED

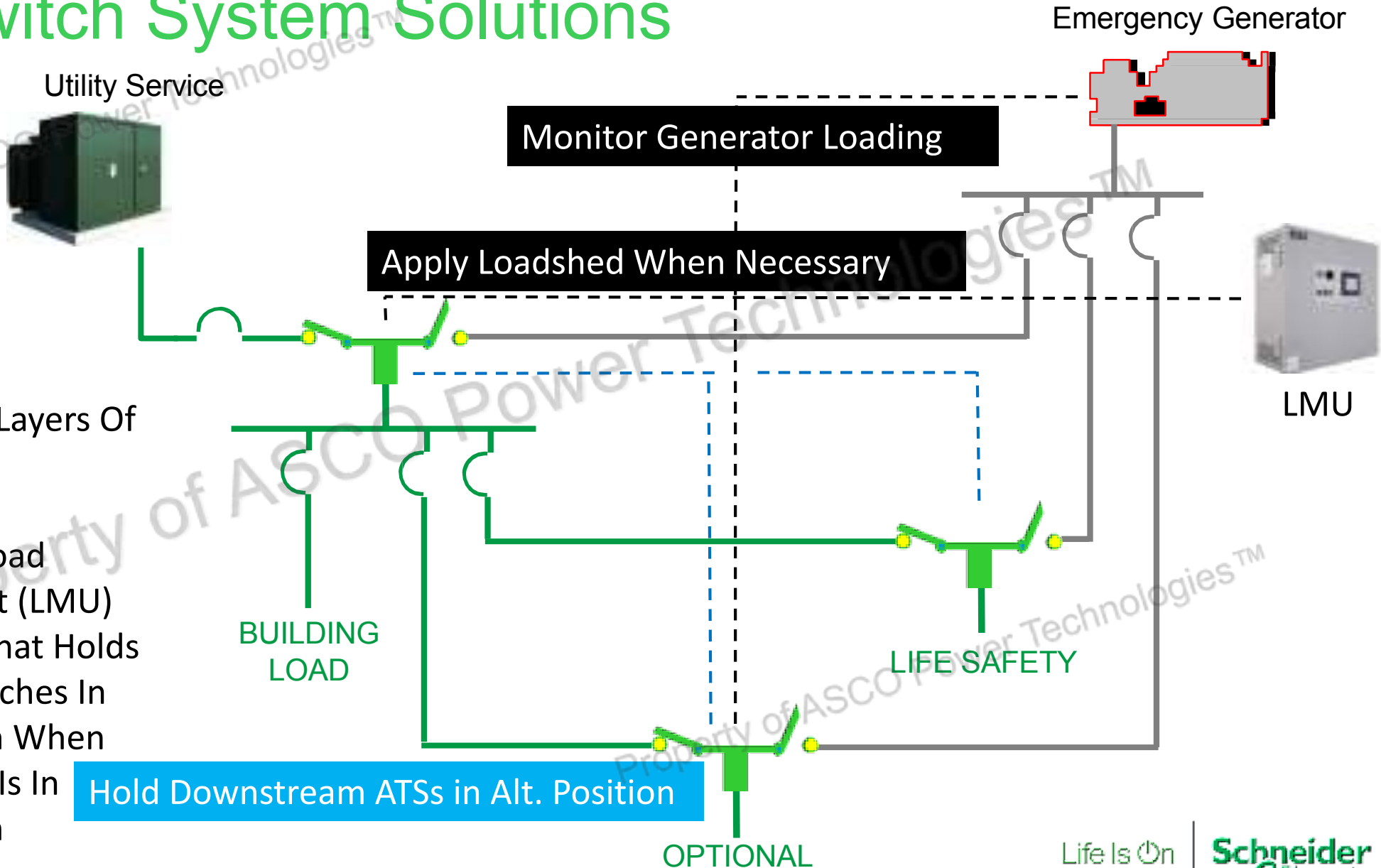

Apply The Following Layers Of Control:

- Small Proactive Load Management Unit (LMU)
- Create Circuitry That Holds Downstream Switches In Alternate Position When Upstream Switch Is In Alternate Position

Additional Considerations

- Connectivity
- Control Power Requirements
- Power Quality Metering
- Bypass-Isolation
- Thermal Monitoring
- Unique Deployment Requirements

Property of ASCO Power Technologies™

Life Is On



Schneider
Electric

Property of ASCO Power Technologies™

Property of ASCO Power Technologies™