

LINK™ ESCALATORS

Make your  
building  
come alive

---

OTIS

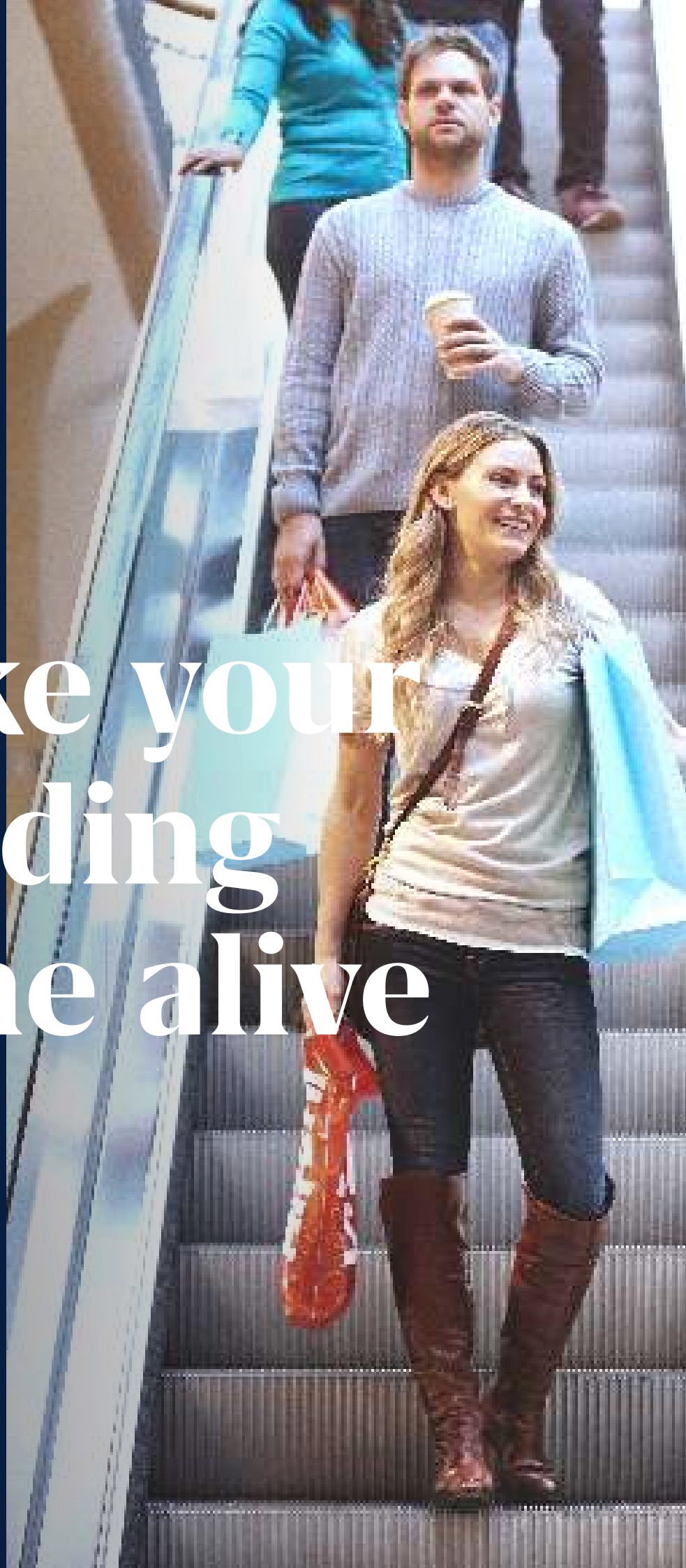

# Connecting your customers to moments that matter

What separates a place from a destination is the experience. That starts with creating a lively atmosphere and moving customers and tenants through space in ways that guide and delight.

That's where Otis can help. Our industry-leading Link escalators have everything you want in an escalator: reliability, safety and style. They are custom-made solutions that complement your unique environment. Otis Link escalators don't just usher people to an experience, they make them a part of it.

## OTIS LINK OVERVIEW

Maximum rise	8 m (26' 2")
Inclination	30°, 35°
Step width	600 mm (24"), 800 mm (32"), 1000 mm (40")
Step chain	Inside roller
Balustrade height	930 mm, 1000 mm, 1100 mm
Application	Indoor, semi-outdoor, outdoor



# Create a unique and seamless experience

Escalators are the grand staircases of your building's entrance. They should complement your architecture and design. Whether you're welcoming patrons into a luxury fashion store or busy travelers to a streamlined, minimalist airport, Link escalators give you the architectural flexibility to create an experience.

## GRACEFUL LINES

From elegantly tapered handrail entry boxes that minimize safety risks to an elongated newel that gives passengers more time to grasp the handrail before getting on, every detail is made to look good and perform even better.

## ARCHITECTURAL FLEXIBILITY

Experience design freedom with a compact escalator footprint and a truss design that can span greater distances without the need for cumbersome intermediate support columns.

## INTEGRATED ILLUMINATION

Match the style of your space with energy-efficient LED lighting. Our balustrade illumination option allows you to change the lighting color with a click of a button.

# Build an experience that lasts

A great experience leaves lasting memories on your customers. It's a shared goal to make sure people keep making those memories for years to come. To do our part, we focus on delivering a more sustainable experience. We have applied innovative thinking every step of the way – from design and manufacturing to installation and throughout the product lifecycle.



## + ENERGY EFFICIENCY

# 60%

less energy used compared to escalators without regenerative drives when using Otis ReGen® drives.\*

## + OPTIMAL LUBRICATION

# 98%

less oil consumed with our high-efficiency lubrication system than manual lubrication systems.

## + SUSTAINABLE DESIGN

# 90%

recyclable materials used to make Link escalators. And all exposed applied finishes use an extremely durable, non-toxic powder coating technique.

\*Based on internal calculations for the following conditions: daily operation of 12 hours with sleep mode. 3.5hrs at no load, 3.75hrs at 25% load, 4.5hrs at 50% load, 0.75hrs at 100% load.

# Engineered to keep your world in motion

Otis moves billions of people every day, and we care about every single one. That's why Link escalators are designed for easy maintenance and maximum uptime. All of our products undergo rigorous performance, safety and lifetime qualification tests and in many cases exceed code requirements. We demand the same standards across our global supply chain. Our commitment to quality ensures Link escalators don't just set your world in motion – they keep everyone moving for years to come.

## ULTIMATE UPTIME

Our step assembly makes it easier to remove and replace steps, reducing maintenance time. Step axles between step chains allow for step removal without compromising alignment. And with our Dr. Step™ diagnostic tool, Otis mechanics can quickly assess escalator performance and quality during a routine service visit.

## BUILT TO LAST

Link escalators are fortified with unique rectangular steel tube trusses for enhanced structural rigidity with seal welds to protect from internal corrosion. Our truss design also spans greater distances without cumbersome intermediate supports.

## DESIGNED TOUGH

We monitor over 50 critical safety features during the manufacturing process. Every step is subjected to a 20 million cycle dynamic load test rather than the standard five million cycles.

# People are at the center of everything we do

We think about our passengers, how they may step or misstep onto a Link escalator, and how they might experience the ride differently. Then we design for safety to deliver the best ride possible.



## SMARTER DESIGN

The tapered handrail entry box design with deflectors hide the entry point and minimize risk of contact by passengers. Safety brushes guide passengers away from skirt panels. And low-friction coating on the skirt panels reduces friction to prevent objects from getting caught.



## ENHANCED MONITORING

Link escalators are equipped with the Multifunction Escalator Safety Device, an advanced electronic safety system that activates the brakes quickly and consistently when it detects an issue.



## SAFER MAINTENANCE

At Otis, safety comes first – whether it's for your riders or our employees. From enhanced safety features in our products to job site procedures like self-audit and hazard scans, we provide improved protection for our service technicians.



# Life never stops moving – we keep it that way

Our mechanics see your building as their own. That's why our 31,000 service professionals work around the clock to keep your equipment operating like new, every day. With our maintenance program, you also have access to our 24-hour customer call center, centralized spare parts delivery and dedicated around-the-clock service support.

## MODERNIZATION MADE EASY

Purchasing an Otis escalator means our team will be there when it's time to upgrade or enhance your escalator with a personalized modernization plan that guarantees the least disruption to your schedule – and your budget.

## TURNING DATA INTO ACTION

As one of the first elevator companies to use big data and predictive analytics to improve performance, we're experts at getting the most out of emerging technology. Our digital ecosystem uses the Internet of Things (IoT) and mobility tools to predict and diagnose issues before they occur. All of this to stay ahead of your needs and to deliver a seamless passenger experience.

## INFORMATION AT YOUR FINGERTIPS

With the eService customer portal and mobile app, you have instant online access to important information about your escalator system – 24 hours a day. You can view performance data, place service calls and handle invoices – all from your computer, tablet or mobile device.

# Going above and beyond

At Otis, we believe that when it comes to safety, just meeting code is not enough. That's why we deliver a wide range of superior safety features to avoid entrapment, freewheeling and other safety risks. See all of our standard and premium safety features at [otis.com](https://www.otis.com) or talk to your sales representative.

01. Anti-static brush for step
02. Comb plate safety device
03. Floor plate contacts
04. Handrail entry device
05. Chain and step wheel control contact
06. Step chain control contacts
07. Missing step device
08. Handrail broken contact
09. Emergency stop button
10. Upthrust track device
11. Skirt panel safety device
12. Handrail speed monitoring device
13. Non-reversal device
14. Overspeed monitoring device
15. Motor thermal device
16. Auxiliary brake



# Customized for your building

With one of the widest selections of finishes for steps, balustrades and railings, our products are designed to harmonize with and enhance any building or project.

## HANDRAILS



## HANDRAIL ENTRY BOX

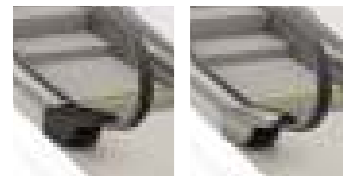

## DECKING

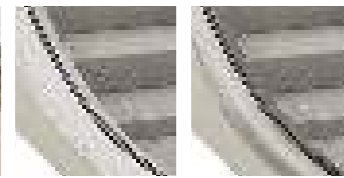

## SKIRT PANEL



## STEP



## BALUSTRADE GLASS PANEL

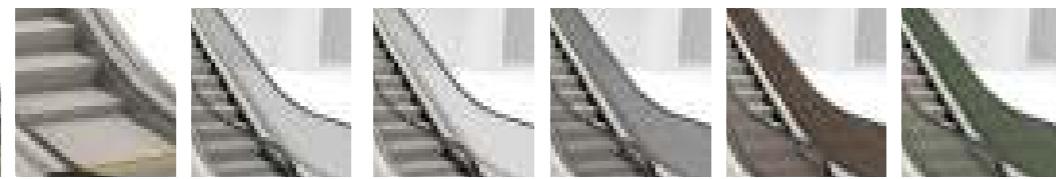

## BALUSTRADE LIGHTING

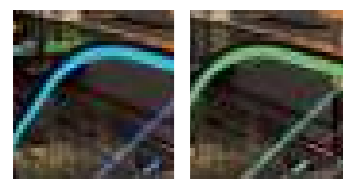

## SKIRT PANEL LIGHTING



## UNDER STEP LIGHTING

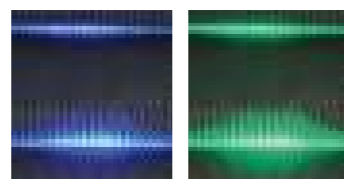

## COMB LIGHTING

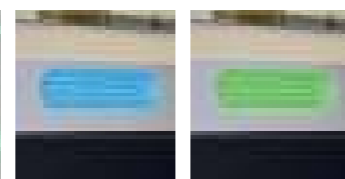

\*Available with yellow demarcation lines

\*Available in White, Red, Blue, Green and Yellow

The power of smarter design is now at your fingertips with the Otis escalator design tool. Easily customize materials, aesthetic features, lighting and more.

> Design your custom escalator at [otis.com](https://www.otis.com)

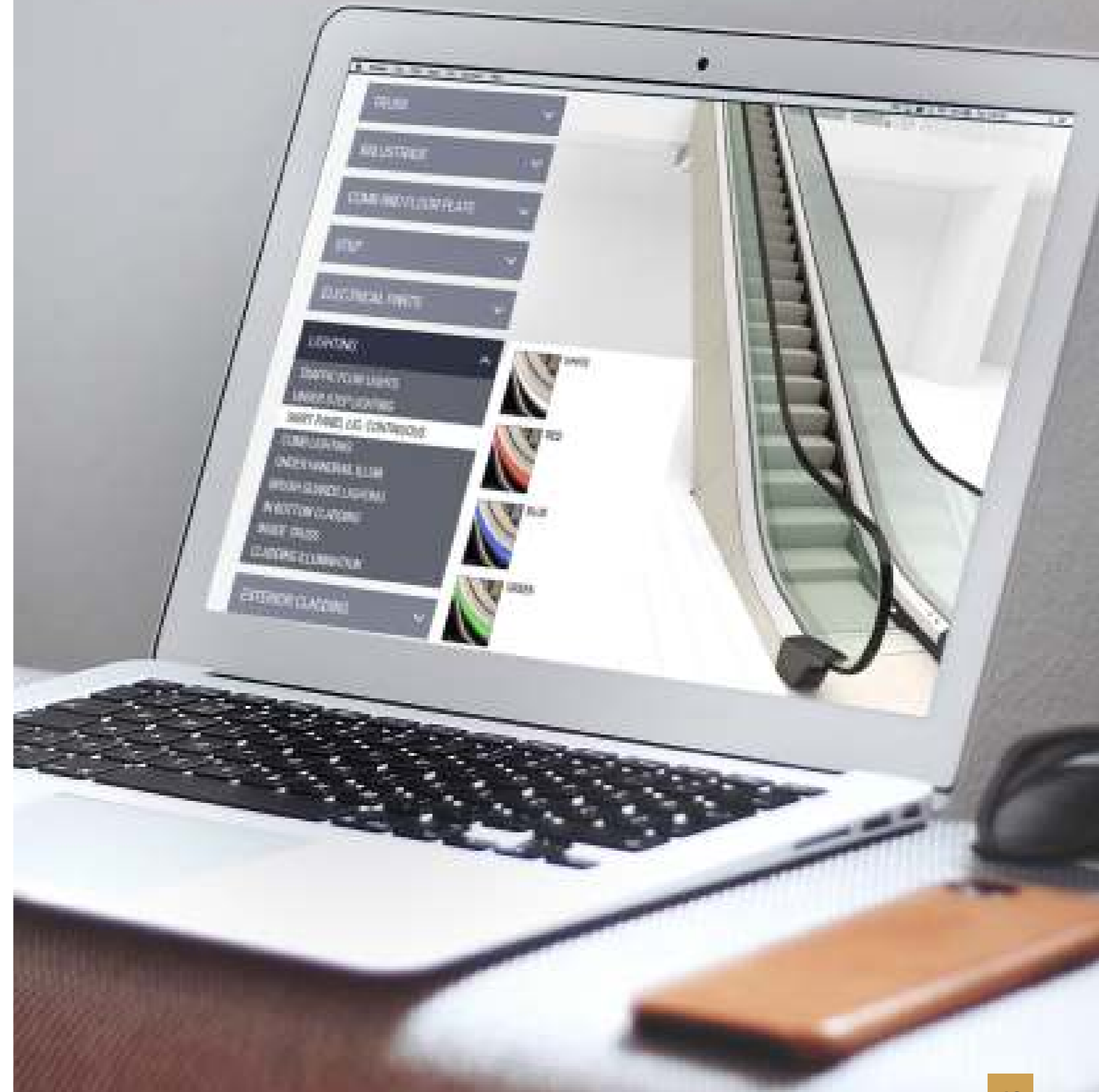

# Link 30° specifications

**MAXIMUM RISE: 8 M / INCLINATION: 30° / SPEED: 0.5 MPS**

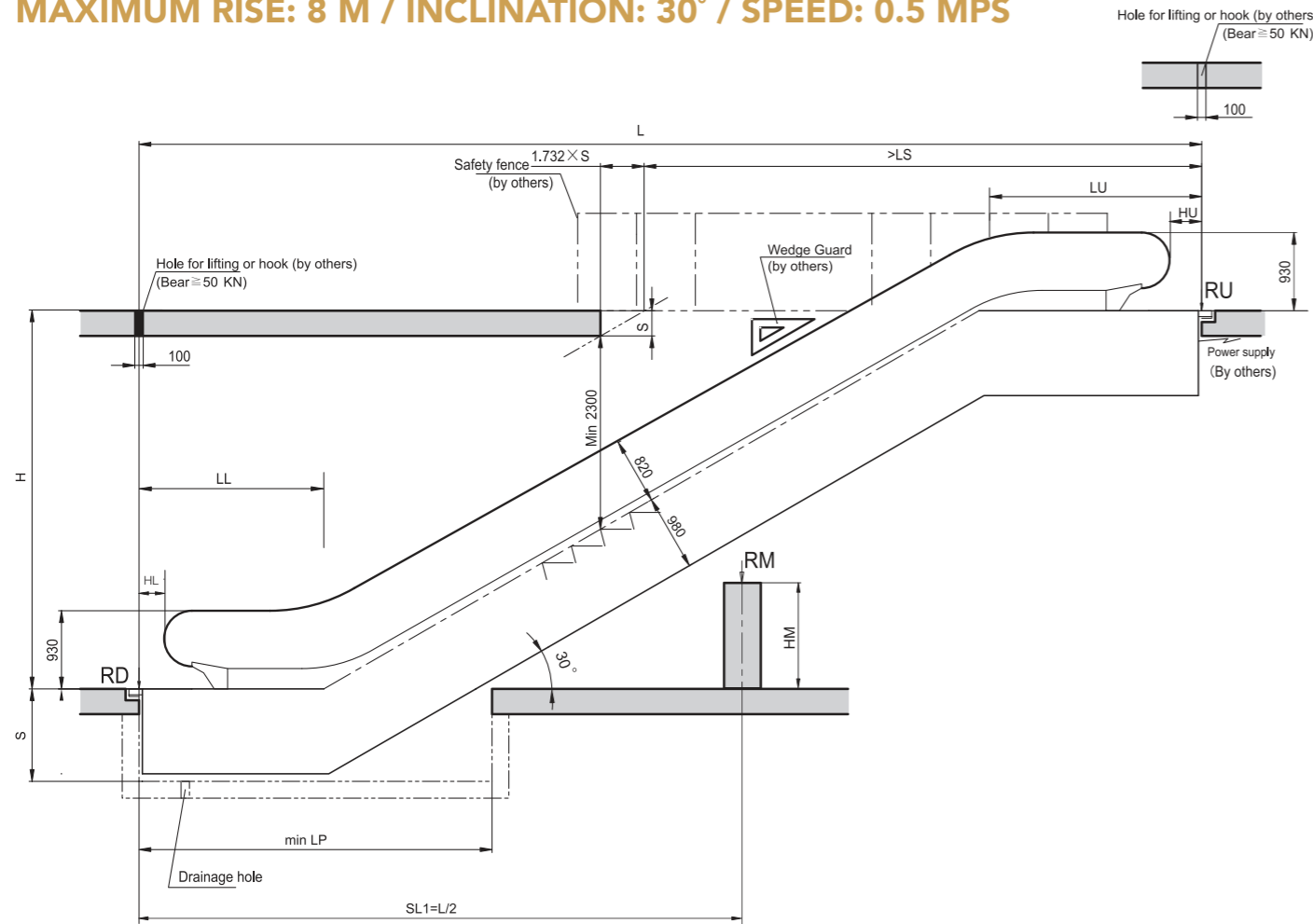

Rise H (mm)	Step Width A (mm)	Span L (mm)	Min LP (mm)	LU (mm)	LL (mm)	LS (mm)	HU* (mm)	HL* (mm)	RU (kN)	RD (kN)	RM (kN)
H ≤ 6000 with 2 flat steps	1000	1.732H+4698	4350	2449	2249	6433	267	267	4.96L+7	4.96L+2.3	-
	800								4.31L+7	4.31L+2.3	-
	600	1.732H+5198		2949	6933	767			3.66L+7	3.66L+2.3	-
6000 < H ≤ 8000 with 3 flat steps	1000	1.732H+5498	4750	2849	2649	6833	267	267	2.03L+5.7	2.03L+2.3	6.46L+1.4
	800								1.78L+5.2	1.78L+2.2	5.74L+1.3
	600	1.732H+5998		3349	7333	767			1.53L+4.8	1.53L+2.0	5.02L+1.3

Note: Dimensions may vary based on code/local requirements as well as choice of machine and drive. Dimensions can be adapted for the replacement of existing escalators. Please contact your local Otis sales representative for details.

\*HU and HL values in table are for 930 mm balustrade height  
Minimum S = 1056 (indoor) and 1256 (outdoor)

Step Width A (mm)	Handrail Center Width B (mm)	Escalator Width C (mm)	Pit Width D (mm)	Truss Width E (mm)
1000	1247	1540	1620	1500
800	1044	1340	1420	1297
600	841	1140	1220	1094

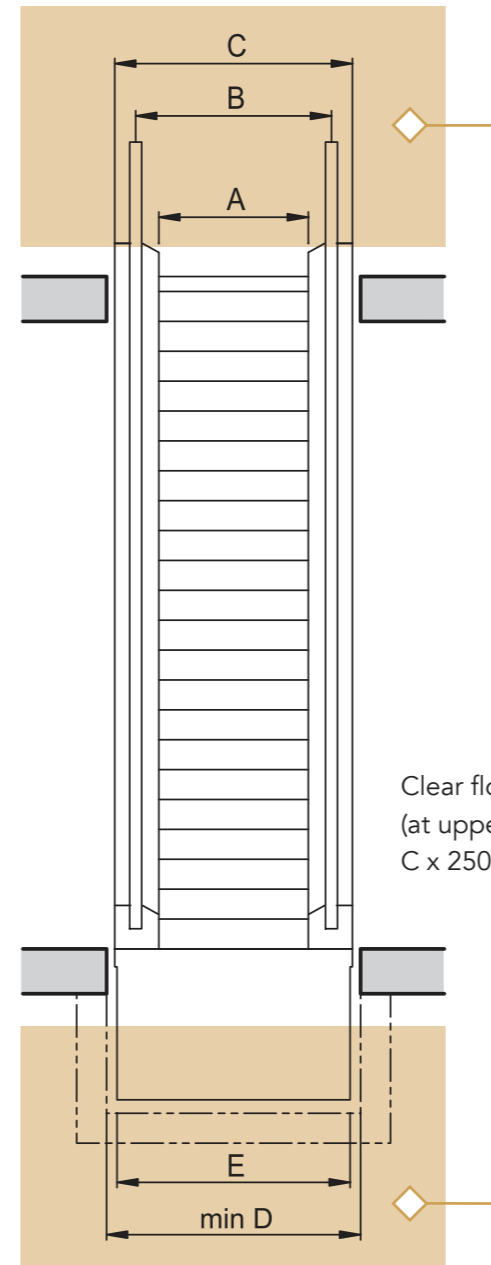

Clear floor access area (at upper and lower landing):  
C x 2500 mm or 2C x 2000 mm

### Steel plate support (standard for upper and lower landing)

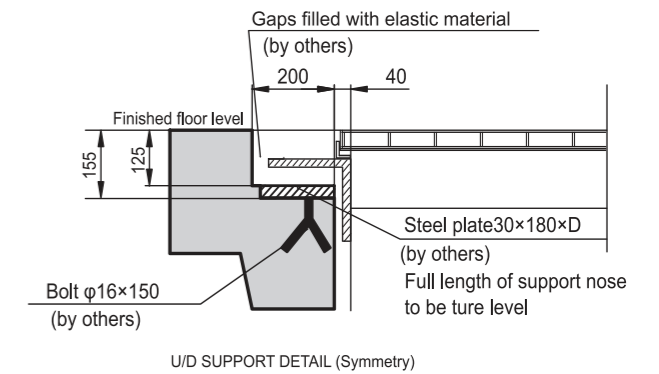

### Anti-vibration support (standard for upper and lower landing)

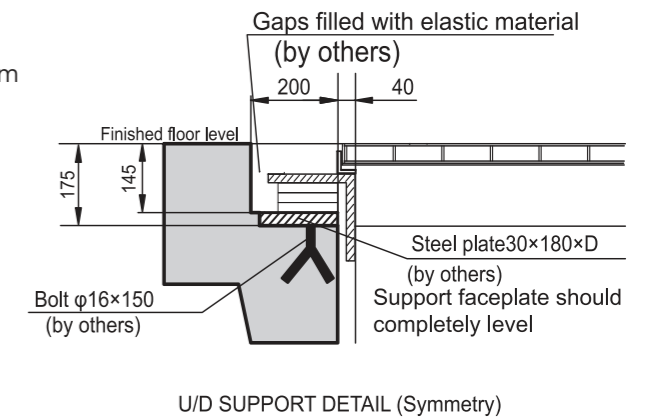

### Intermediate support (needed if L > 15.24m)

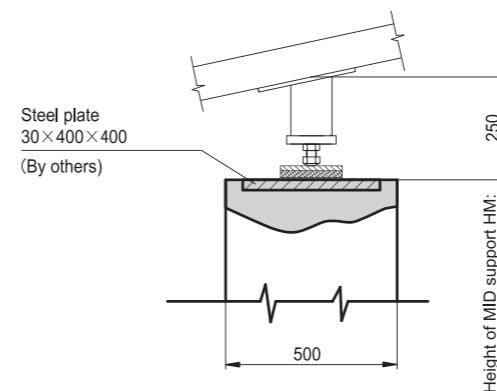

Position of intermediate support is at center of span

Height of intermediate support beam:

**For 6000 < H ≤ 8000,**  
 $HM = (SL1 - 2649) \times \tan 30^\circ - (980 / \cos 30^\circ) - 250$

**For H ≤ 6000,**  
 $HM = (SL1 - 2249) \times \tan 30^\circ - (980 / \cos 30^\circ) - 250$

# Link 35<sup>0</sup> specifications

**MAXIMUM RISE: 6 M / INCLINATION: 35° / SPEED: 0.5 MPS**

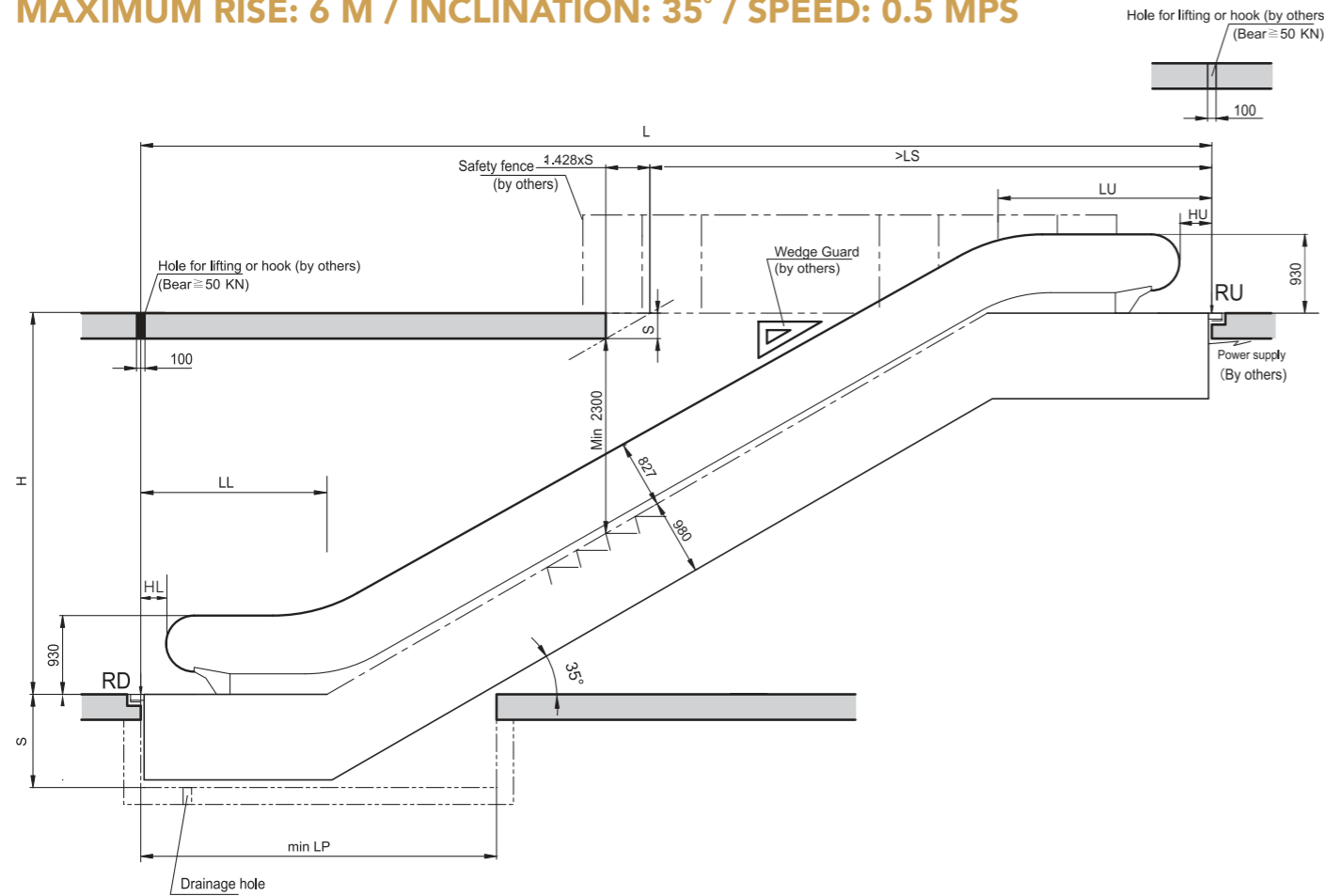

Rise H (mm)	Step Width A (mm)	Span L (mm)	Min LP (mm)	LU (mm)	LL (mm)	LS (mm)	HU* (mm)	HL* (mm)	RU (kN)	RD (kN)
H≤6000 with 2 flat steps	1000	1.428H+4793	4200	2477	2316	5761	267	267	5.11L+7	5.11L+2.3
	800								4.41L+7	4.41L+2.3
	600	1.428H+5293		2977					6261	767

Note: Dimensions may vary based on code/local requirements as well as choice of machine and drive. Dimensions can be adapted for the replacement of existing escalators. Please contact your local Otis sales representative for details.

\*HU and HL values in table are for 930mm balustrade height. Minimum S = 1056 (indoor) and 1256 (outdoor)

Step Width A (mm)	Handrail Center Width B (mm)	Escalator Width C (mm)	Pit Width D (mm)	Truss Width E (mm)
1000	1247	1540	1620	1500
800	1044	1340	1420	1297
600	841	1140	1220	1094

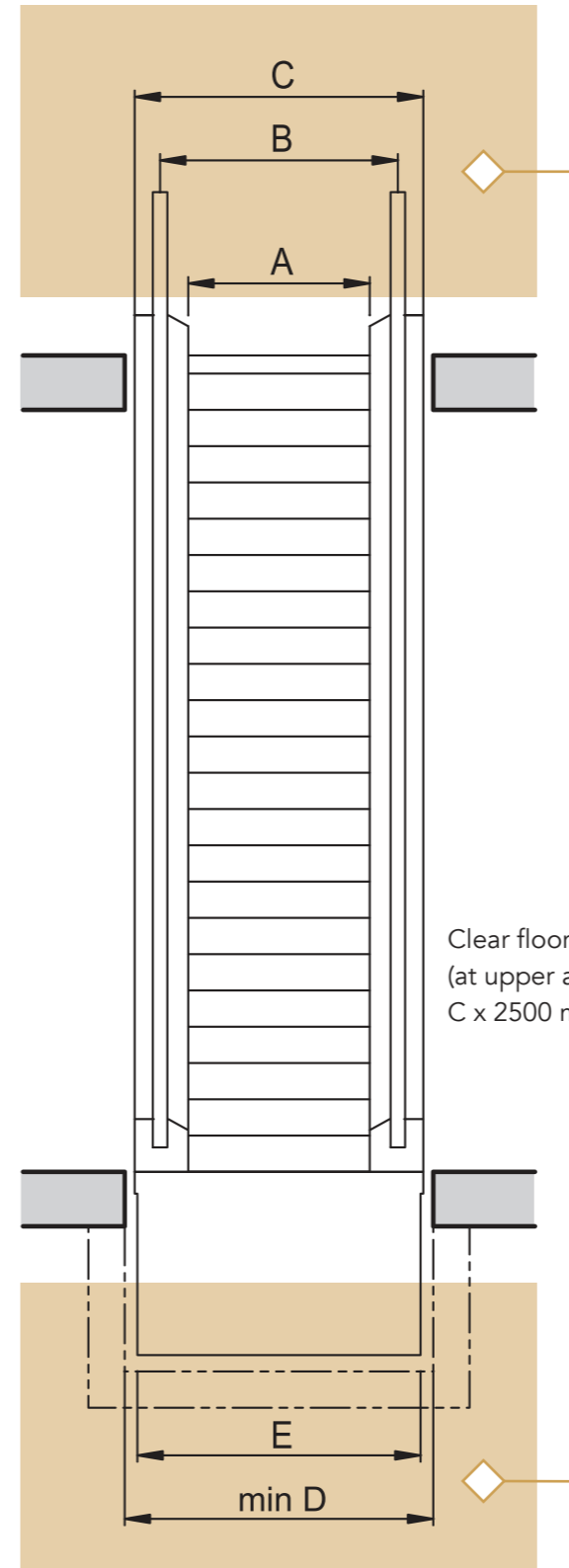

### Steel plate support (standard for upper and lower landing)

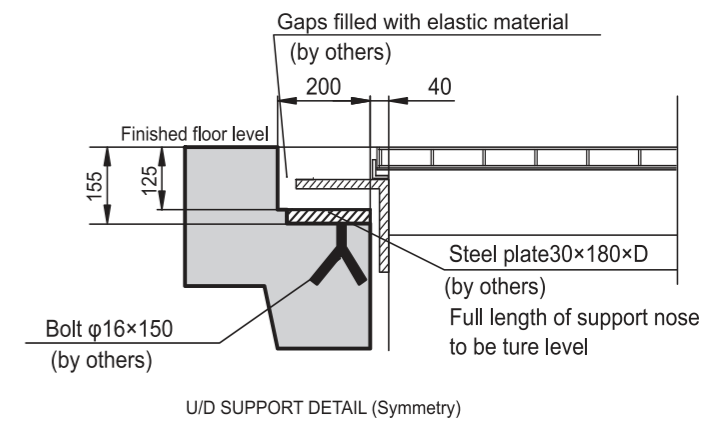

### Anti-vibration support (standard for upper and lower landing)

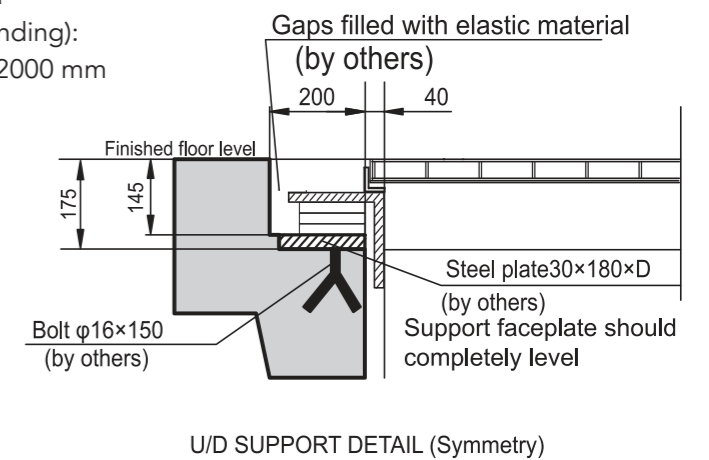

# Let's build something unique, together

From the most fashionable malls to busy city centers and everything in between, you'll find Otis escalators in the world's most iconic buildings. Put our extensive experience to work on your unique project. Otis can help you plan and install the right escalator system for your building and create an optimal service plan to keep your environment in motion. We believe your customers and tenants aren't the only ones who deserve a great experience – you do too.

## LINK ESCALATORS COMPLEMENT OTHER VERSATILE OTIS EQUIPMENT

- + GEN2® ELEVATORS**  
High-performance elevator series for residential and commercial buildings
- + MOVING WALKWAYS**  
Stylish and reliable moving walks for supermarkets, department stores and airports
- + SKYRISE® ELEVATORS**  
Premier high-rise elevator systems



— Otis Elevator Company is the world's largest manufacturer and maintainer of people-moving products including elevators, escalators and moving walkways. With headquarters in Farmington, Connecticut, Otis employs 60,000 people globally, offers products and services in approximately 200 countries and territories and maintains more than 2 million elevators and escalators worldwide. United Technologies Corp., based in Hartford, Connecticut, is a diversified company providing high technology products and services to the building and aerospace industries.