

Power and Distribution Transformers



Global Transformer Presence

Schneider Electric has a large network of transformer manufacturing plants around the world, producing medium power transformers, oil distribution and dry-type transformers and special transformers.

Having a worldwide footprint

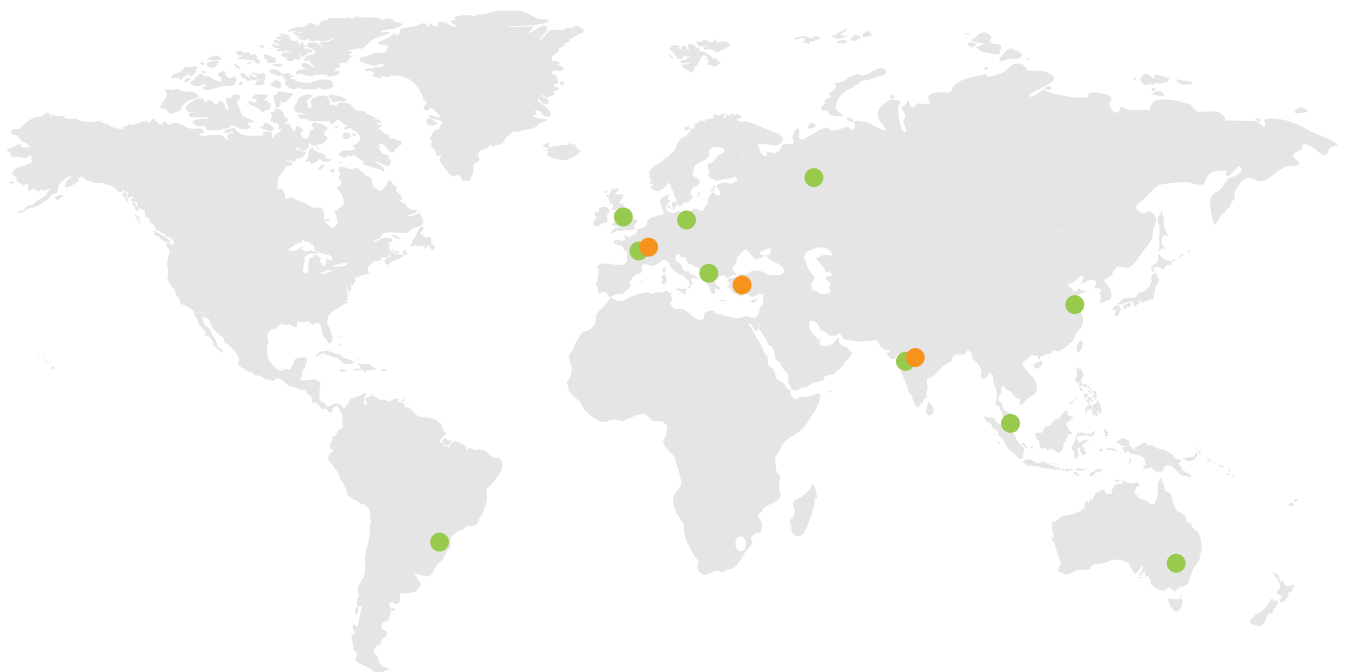

 **3** Competency centres

 **15** Industrial sites



Schneider Electric: Best In Class Transformer at the right place for the right job!

Producing medium power, oil distribution and dry-type transformers and special transformers to address each and every customer requirement.

Schneider Electric's worldwide presence and excellence assures the quality of the Transformers; high performance and safety, environmental friendly, reliable, safe, efficient, robust and 100% integrated with other Schneider Electric solutions.

Discover our Transformer offer compliant with today and tomorrow's international and specific standards & regulations (IEC, ANSI, BS, GOST, IEEE, IS, BS, etc.), built with proven technology and a deep know how!

Schneider Electric know-how guarantees the best Transformers.

| | |
|---|-----------|
| Transformers | 6 |
| Selection table | 6 |
| <hr/> | |
| Oil Distribution Transformers | 8 |
| Minera | 8 |
| Minera Pole-Mounted Transformers | 9 |
| Minera HE+ High Efficiency Transformers | 10 |
| <hr/> | |
| Cast Resine Transformers | 11 |
| Trihal - Cast Resin Transformers | 11 |
| Tricast - Cast Resin Transformers | 12 |
| Resiglas - Epoxy Resin / Fiberglass Transformers | 13 |
| <hr/> | |
| Medium Power Transformers | 14 |
| Minera MP | 14 |
| <hr/> | |
| Special Transformers | 15 |
| Minera SGrid Transformers | 15 |
| Minera Ex Explosive Area Transformers | 16 |
| Minera R - Oil-immersed rectifier Transformers | 17 |
| Minera E - Earthing Transformers | 18 |
| Minera PV Transformers for Photovoltaic Systems | 19 |
| Siltrim - Compact Size Transformers | 20 |
| Vegeta - Biodegradable vegetable oil Transformers | 21 |
| Imprego | 22 |
| Imprego AT | 22 |
| R-Cool - Air Conditioned Special Dry-Type | 23 |
| <hr/> | |
| Technical Information | 24 |
| Three-Phase Common Transformer Vector Groups | 24 |
| Transformer Calculations | 25 |
| EcoDesign Regulation EU 548-2014 | 29 |
| Total Cost of Ownership | 31 |

Oil Distribution Transformer up to 3.15 MVA



| | Minera | Minera Pole-Mounted | Minera HE+ |
|--------------------------|--|---|---|
| Max. rated power (MVA) | 3.15 | 0.5 | 1.6 |
| Max. rated voltage (kV) | 36 | 36 | 36 |
| Indoor/outdoor | Indoor and outdoor | Outdoor | Indoor and outdoor |
| Features and application | Ground-mounted and pole-mounted oil-immersed transformer. Three-phase units. | Pole-mounted oil-immersed transformer. Three-phase units (single-phase available on request). | High efficiency transformer with amorphous core technology. |
| Catalogue Page No. | Page 8 | Page 9 | Page 10 |

Cast Resin Transformers



| | Trihal | Tricast | Resiglas |
|--------------------------|--|---|---|
| Max. rated power (MVA) | 15 | 25 | 25 |
| Max. rated voltage (kV) | 36 | 52 | 36 |
| Indoor/outdoor | Indoor and outdoor | Indoor and outdoor | Indoor and outdoor |
| Features and application | Cast resin dry transformer. Indoor: IP00, IP21 or IP31 Outdoor IP44. Highly rated to standards for environmental, climate and fire resistance. | Cast resin dry transformer Indoor: IP00, IP21 or IP31 Outdoor IP44. Highly rated to standards for environmental, climate and fire resistance. | Suitable for power supply of non-linear loads with high harmonic contents (transformers with k-factor). Has a flexible design (adjustment of impedances). |
| Catalogue Page No. | Page 11 | Page 12 | Page 13 |

Medium Power Transformers



| | Minera MP |
|--------------------------|--|
| Max. rated power (MVA) | 100 |
| Max. rated voltage (kV) | 170 |
| Indoor/outdoor | Indoor and outdoor |
| Features and application | Hermetically sealed or breathing with conservator. Low flammability dielectric liquids (Vegeta ranges). High capacity of cooling options such as ONAN, ONAF, ODAF, OFAF or OFWF. |
| Catalogue Page No. | Page 14 |

Special Transformers Solutions

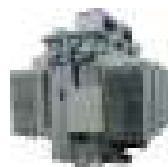
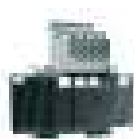

| | Minera SGrid | Minera Ex | Minera R | Minera E |
|--------------------------|--|---|---|---|
| Max. rated power (MVA) | 1 | 60 | 80 | 15 kA (earth fault current) |
| Max. rated voltage (kV) | 36 | 36 | 170 | 72 |
| Indoor/outdoor | Indoor and outdoor | Indoor and outdoor | Indoor and outdoor | Indoor and outdoor |
| Features and application | Transformer suitable. It features an on-load tap changer. Voltage stabilization. | Zone 1 and Zone 2 explosion proof transformer for mines and the oil and gas industries. Hazardous zones (Atex / IECEx Transformer range). Naturally cooled (ONAN) or air forced (ONAF). | Rectifier transformer for railways, metals and renewable. Rectifier feeder (Rectifier Transformer range). | Earthing transformer. Designed to create the HV network neutral point and to limit the fault current in the phase-earth connection. |
| Catalogue Page No. | Page 15 | Page 16 | Page 17 | Page 18 |



| | Minera PV | Siltrim | Vegeta |
|--------------------------|---|--|---|
| Max. rated power (MVA) | 3.2 | 3.3 | 25 |
| Max. rated voltage (kV) | 36 | 36 | 72.5 |
| Indoor/outdoor | Indoor and Outdoor | Indoor and outdoor | Indoor and outdoor |
| Features and application | Transformer for photovoltaic (PV) generation. Natural cooled (ONAN) or air-forced (ONAF). | Very compact distribution transformer adapted to fit into reduced spaces such as wind towers and offshore oil & gas platforms. | The safest transformer for the environment and people using biodegradable vegetable oil as dielectric medium. |
| Catalogue Page No. | Page 19 | Page 20 | Page 21 |



| | Imprego | Imprego AT | R-Cool |
|--------------------------|---|--|--|
| Max. rated power (MVA) | 0.4 | 0.4 | 15 |
| Max. rated voltage (kV) | 1.1 | 1.1 | 36 |
| Indoor/outdoor | Indoor and Outdoor | Indoor and Outdoor | Indoor and Outdoor |
| Features and application | Where the earthing system needs to be changed or as an isolation transformer. | Autotransformer applications including stepping voltage up or down without isolating the secondary or primary. | Air-conditioned special dry-type transformer, which is designed to achieve high IP ratings and an efficient cooling solution that can not be reached with conventional enclosures and cooling. |
| Catalogue Page No. | Page 22 | Page 22 | Page 23 |

Minera

Up to 3.15 MVA and 36 kV

Applications

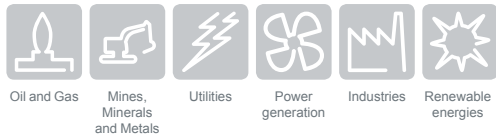

Minera

Schneider Electric follows a policy of continuous improvement taking into account the latest worldwide developments. This ensures that our transformers are state-of-the-art and fully compliant with the modern world’s highest requirements: fast delivery time, improved quality and recycling capacities, reduced size and, on request, very low noise and losses values.

With a large industrial worldwide platform, we offer versatility and flexibility and are able to deliver you the oil-immersed distribution transformer to meet your needs. Whatever the transformer type you require, you will find your solution in Minera.

We can deliver every type of Minera:

- Hermetically sealed or breathing type
- For indoor applications in buildings or industrial plants and in compact distribution substations
- For outdoor applications: ground-mounted but also pad or pole-mounted
- Low noise level for urban or residential areas
- Normal, low, or very low level of losses

All our production sites of Minera oil-immersed transformers are ISO 9001, ISO 14001 and ISO 18001 certified.

Technical Characteristics

| | |
|---------------------------|---|
| Rated power | 3.15 MVA |
| Rated voltage | 36 kV |
| Phases | Three-phase unit |
| Rated frequency | 50 Hz or 60 Hz |
| Type of cooling | ONAN, ONAF (other on request) |
| Voltage regulation | Off-circuit tap changer (DETC) or on load tap changer (OLTC) |
| Other (optional) | Breathing or sealed type, standard or low noise levels, a wide variety of accessories |

Minera Pole-Mounted Transformers

Up to 500 kVA and 36 kV

Applications

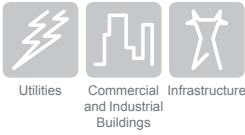

Utilities

Commercial and Industrial Buildings

Infrastructure



Minera Pole-mounted Transformer



The Minera pole-mounted range is an outdoor range of pole-top oil-filled transformers. Rated from 10 kVA to 500 kVA, single or three-phase at 12 kV, 24 kV and 36 kV.

A wide range of oil-immersed transformers and transformer solutions are designed to meet different specifications and applications.

Technical Characteristics

| | |
|-------------------------|------------------------------|
| Rated power | Up to 500 kVA |
| Rated voltage | 12, 24 and 36 kV |
| Phases | Three-phase and single-phase |
| Rated frequency | 50 Hz |
| Type of cooling | ONAN |
| Other (optional) | Oil temperature indicator |

Minera HE+ High Efficiency Transformers

Up to 1600 kVA and 36 kV

Applications



Minera HE+



Minera HE+ Transformer

High efficiency transformer correspond to an equipment design with low level of losses to ensure reduced cost of ownership for end user. The losses can be divided into two categories: load losses, which are proportional to the transformer load; and no-load losses, which are caused by the magnetisation of the core steel and are constant - independent of the transformer load.

Schneider Electric provides a full range of energy-efficient solutions to suit your exact needs. In addition to the existing high efficiency Minera HE transformers, Schneider Electric offers a new technology product range; amorphous core transformers Minera HE+, which provide even greater energy savings. Minera HE+ is an ultra high efficiency amorphous transformer, which is more economical than "standard efficiency" transformers, as it consumes 70% to 80% less energy than conventional silicon steel transformers.

Technical Characteristics

| | |
|------------------------|---|
| Rated power | Up to 1600 kVA |
| Rated voltage | Up to 36 kV |
| Phases | Three-phase (single-phase available upon request) |
| Rated frequency | 50 Hz or 60 Hz |
| Type of cooling | ONAN, KNAN (other on request) |

What is Amorphous Core Technology?

Amorphous metal is a solid metallic material with high magnetic conductivity that provides energy saving performance. The metal atoms are disordered and arranged in a non-crystalline way. Amorphous metal is easier to magnetise and demagnetize than conventional silicon steels. Its thickness, 0.02 mm is about 1/10 the thickness of conventional steel.

Advantages of Amorphous Metal Magnetic Core

- Reduction of magnetising current
- Lower temperature rise of core
- Low-loss, especially no-load losses divided by three more than conventional steel
- Lower greenhouse emissions.

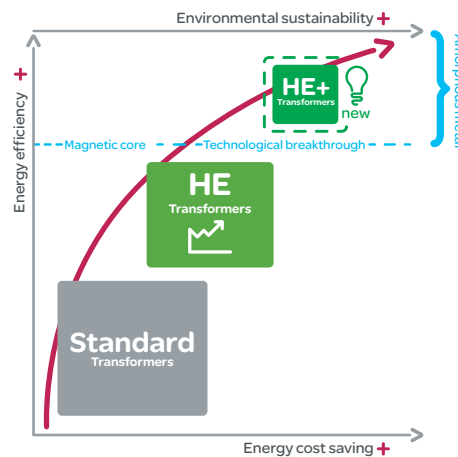

Trihal - Cast Resin Transformers

Dry-Type Transformers

up to 15 MVA and 36 kV

Applications

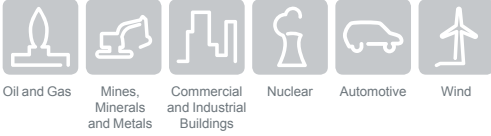

Trihal with Enclosure



Trihal Dry-Type Transformer

For high safety and exceptional environmental friendliness, there's no matching a dry-type cast resin transformer.

Trihal is a best-in-class high-quality transformer that performs reliably in a wide range of environments. It's perfectly suited to a wide variety of industries, from highly populated buildings and critical infrastructure to heavy industry and renewable energy production.

Technical Characteristics

| | |
|------------------------|---|
| Rated power | Up to 15 MVA |
| Rated voltage | Up to 36 kV |
| Rated frequency | 50 Hz or 60 Hz |
| Type of cooling | AN, AF (other on request) |
| Other | Thermal protection system |
| On request | Enclosure, fans, anti-vibration pads, plug-in bushing, monobloc bushing, automatic voltage regulator panel, surge arrestors, etc. |

Safety and Reliability

To ensure total compliance with relevant national and international standards, Trihal transformers have been put through the most stringent series of tests. Trihal is one of few transformers having successfully passed these tests and is characterised by the following features:

- C3 – Climate Test – Operation and Storage to -50°C
- E3 – Environment Test – Nearly total condensation or heavy pollution or both
- Abnormal level of humidity up to 95% to IEC 60076-16
- F1 – Fire Behaviour – reduced flammability and self extinguishing
Excellent classification to IEC 60076-11 standard
- ≤ 5pC – Special test for Partial Discharge based on IEC 60076-11;
Tested at 1.3 Un with ≤ 5pC result.

Tricast - Cast Resin Transformers

Dry-Type Transformers

up to 25 MVA and 52 kV

Applications



Tricast Dry-Type Transformer

With today’s focus on improving environmental impact and preserving the earth’s natural resources, Schneider Electric’s contribution is to manufacture safe and environmentally friendly equipment: Tricast

High quality and reliability make Tricast Cast Resin Dry-Type Transformers the perfect solution for infrastructure projects such as transmission and distribution substations, public buildings and high-rise developments.

As Tricast is self-extinguishing, it provides an effective solution for use in industrial installations susceptible to fire hazards. In addition, it meets the needs of special applications such as wind farms.

Technical Characteristics

| | |
|------------------------|---|
| Rated power | 25 MVA |
| Rated voltage | 52 kV |
| Rated frequency | 50 Hz or 60 Hz |
| Type of cooling | AN, AF (other on request) |
| Other | Thermal protection system |
| On request | On-load tap changer, enclosure, fans, antivibration pads, plug-in bushing, monobloc bushing, automatic voltage regulator panel, surge arrestors, etc. |

Safety and Reliability

To ensure total compliance with relevant national and international standards, Tricast transformers have been put through the most stringent series of tests. Tricast is one of few transformers having successfully passed these tests and is characterised by the following features:

- C2 – Climate Test – Operation and Storage to -25°C
- E2 – Environment Test – Frequent condensation or heavy pollution or both
- Relative humidity up to 93%
- F1 – Fire Behaviour – reduced flammability and self extinguishing
Excellent classification to IEC 60076-11 standard
- ≤ 10pC – Routine Test for Partial Discharge.

Resiglas - Epoxy Resin / Fiberglass Transformers

Dry-Type Transformers up to 25 MVA and 36 kV

Applications

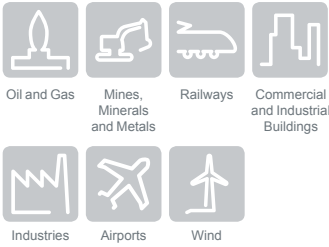

Resiglas

Schneider Electric wants to meet such expectations by manufacturing products that are safe and environmentally friendly. High quality and reliability make Resiglas transformers ideal solutions for investment projects such as: transformer stations, production plants or public use buildings (shopping centres, subway, etc.)

Resiglas transformers are equipped with MV coils reeled using "wet" technology; the product itself is made of non-flammable and fire retardant materials. Therefore, it is perfect for application where the use of other types of transformers is impossible because of safety and difficult working conditions, e.g. in industrial installations susceptible to fire hazards. Additionally, it is suitable for internal use as a substitute for oil transformers.

Technical Characteristics

| | |
|-----------------|--|
| Rated power | Up to 25 MVA |
| Rated voltage | Up to 36 kV |
| Phases | One or three-phase unit |
| Rated frequency | 50 Hz or 60 Hz |
| Type of cooling | AN (other on request) |
| Other | Provided with protection levels up to IP55 |

Safety and Reliability

In order to ensure full compliance with all national and international standards, Resiglas cast resin transformers were subject to the most demanding tests. Thanks to successful test results, transformers may be characterised as follows:

Standard offer

- C2 – resistance to thermal shocks
- E2 – Environment Test – resistance to environment corrosivity
- Relative air humidity at 20°C - to 95%
- F1 – Fire Behaviour – fire retardant or non-flammable and self-extinguishing
- ≤ 10pC – Routine Test for Partial Discharge - Resiglas transformers withstand large changes in load and overload.

Resiglas adapted to special applications

Flame resistant and self-extinguishing, Resiglas provides an effective solution for infrastructure projects and public buildings confronted by fire hazards as well as special applications.

Minera MP

Up to 100 MVA and 170 kV

Applications

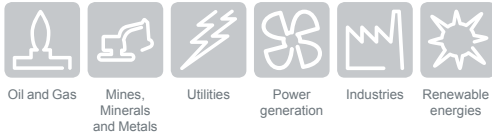

Minera MP Transformer

The Minera oil-immersed medium voltage power transformer is dedicated to all applications up to 170 kV and 100 MVA. Schneider Electric technical expertise and know how allow to propose a wide variety of reliable transformers to meet customer requirements for both utility and industrial applications even the most demanding such as Oil and Gas.

Technical Characteristics

| | |
|---------------------------|---|
| Rated power | From 3.15 up to 100 MVA |
| Rated voltage | Up to 170 kV |
| Phases | One or three-phase unit |
| Rated frequency | 50 Hz or 60 Hz |
| Type of cooling | ONAN, (ONAF, OFAF, ODAF, OFWF or ODWF on request) |
| Voltage regulation | Off-circuit tap changer (DETC) or on load tap changer (OLTC) |
| Other (optional) | Breathing or sealed type, standard or low noise levels, a wide variety of accessories |

Magnetic Core

The transformer's magnetic core is manufactured from a high grade, cold-rolled, grain-oriented silicon steel. The lamination stacking is either butt-lap or step-lap-type. The magnetic core is generally a multi-layer circular cross-section and the slitting and cutting of the magnetic core is made by automated machines.

In order to reduce transformer sound level to a minimum, the magnetic core and its framework are carefully sized to minimise the vibrations and, in particular, magnetostriction effects, which constitute the main sources of sound in medium power transformers.

Moreover, in order to reduce the no-load losses and / or the no-load transformer current, the quality of the magnetic steel and the induction, together with the design of the magnetic core, are carefully chosen to meet the requirements.

Tank construction

The main tank construction type is panel radiator type. The corrugated wall tank is also available in some ranges. Radiators are welded or removable. Tank welding is done by qualified welders. To validate the oil-tightness after complete assembly, the tank is leak tested under gas or liquid overpressure.

High voltage winding

The high voltage winding material is copper or Aluminium according to the rated power. To obtain a controlled temperature gradient, the cooling ducts are added in the coil. High voltage coils are in long layers or disc type. Due to recent developments in the winding process, interlayer insulation and wire insulation have allowed the automation of the winding process. The tap changers allow voltage adjustment for a variation of the supply network voltages on the primary side of the transformer or for increasing or decreasing the secondary voltage. Tappings are provided on the primary winding connected to an off-circuit or on-load tap changer. The operating handle for hand operated tap changer is mounted outside. In general, tapping range for off-load tap changer is 3, 5 or 7 position and for on-load tap changer it is from 7 to 27 positions.

We provide tap position & range as per customer requirements.

Low voltage windings

The low voltage winding material is copper or Aluminium according to the rated power. The shape of the conductor is rectangular or foil type. To obtain a controlled temperature gradient, cooling ducts are added in the coil. The low voltage winding is built around the magnetic core. An insulating barrier is wound or installed around the low voltage coil in order to provide an electrical separation between LV and HV coils.

Surface protection

One of our mayor quality commitment is to provide high-quality surface protection. Our transformers, certified ISO 12944-5:2007, are corrosion resistant and painting (coating) is chosen depending on different environmental conditions, quality of the surface preparation and expected level of durability. Durability of the painting is classified as limited, middle and high durability. We are able to provide to a customer with the durability classes that he needs, from C3 medium durability to C5-M or C5-I high durability class.

Minera SGrid Transformers

Up to 1 MVA and 36 kV

Applications



Minera SGrid-Booster Solution



Minera SGrid

Minera SGrid is a regulated distribution transformer created to help distribution network owners eliminate the risk of voltage fluctuation. It's an innovative answer to voltage regulation, based on proven technology and designed for compliance with key modern regulations.

Whether intended for new substations or retrofit in existing locations, Minera SGrid helps you improve network quality on its own.

Technical Characteristics

| | |
|------------------------|------------------|
| Rated power | Up to 1000 kVA |
| Rated voltage | Up to 36 kV |
| Phases | Three-phase unit |
| Rated frequency | 50 Hz |
| Type of cooling | ONAN |

The intelligent answer to voltage fluctuation

Minera SGrid solves the modern problem of voltage fluctuation using field-proven components. The result is greater reliability and peace of mind for network operators.

But how does it work? Minera SGrid's primary components include:

- A serial transformer working together with the conventional active part
- A set of low-current LV contactors
- A PLC to control operations.

The serial transformer keeps voltage output within a specified range by using the contactors to manage the step process. Most importantly, all parts overseeing voltage regulation are located outside the transformer tank. This greatly simplifies maintenance and makes it easy to adjust regulation as needed.

Minera Ex

Explosive Area Transformers

Up to 60 MVA and 36 kV

Applications



Oil and Gas Mines,
Minerals
and Metals

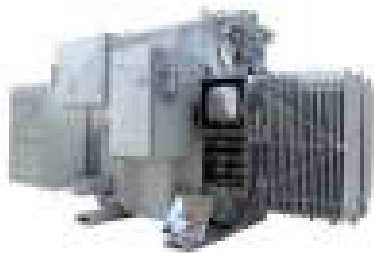

Minera Ex Transformer

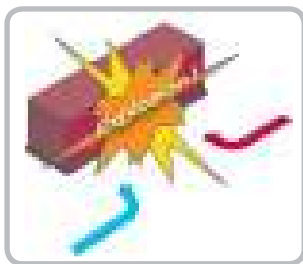

Oil-immersed transformers can be installed in explosive atmospheres, particularly around hydrocarbon fluids. In this case, explosion proof transformers in accordance with the relevant standards can be supplied. Based on decades of field-tested experience in electrical generation and distribution for both offshore and onshore installations, Schneider Electric has adapted transformers to provide safety solutions for Zone 1 and Zone 2 applications in accordance with the latest ATEX and IECEx standards.

Technical Characteristics

| | |
|-------------------------|--|
| Rated power | Up to 60 MVA |
| Rated voltage | Up to 36 kV |
| Phases | Three-phase units (single-phase available on request) |
| Rated frequency | 50 Hz or 60 Hz |
| Type of cooling | ONAN, (ONAF on request) |
| Other (optional) | Hermetically sealed or conservator; ground-mounted with normal, low noise or very low noise levels |

How Do Explosions Occur?

An explosion is any uncontrolled combustion wave. Many manufacturing and processing industries generate potentially explosive atmospheres using substances ranging from solvents to baking flour. An explosion can be produced due to the combination of fuel, an oxidizer (such as the oxygen in the air) and a source of ignition energy. To avoid ignition, the following actions can be taken:

- use special terminal boxes
- avoid non-essential accessories
- use ex-type cable boxes and glands
- use intrinsically safe relays.

What can cause ignition?

Keeping in mind that every material has an Autogenous Ignition Temperature (AIT) at which it will ignite spontaneously, some of the more common ignitors are Accessory contacts, Bushing live parts, Liquide leakage, Sparks, Arcs and Other electrical live parts.

What can we do to avoid ignition?

- By using special terminal boxes
- By avoiding non-essential accessories
- By using ex-type cable boxes and glands
- By using intrinsically safe relay.

Minera R Oil-immersed rectifier Transformers

Up to 80 MVA and 170 kV

Applications

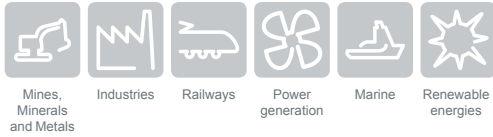

The electrical and mechanical design of the Schneider Electric rectifier transformer is based on decades of experience in transformer design for both medium and high voltage ranges, expert calculation and CAD programming. They are oil-type transformers filled with mineral, silicone or vegetable oil. They operate at the fundamental frequency of an alternating current system and are designed to have one or more output windings connected to the rectifier. It is possible to make major changes in the output current and voltage by using the transformer with a different rectifier configuration.

Rectifier transformers that are designed for treating high harmonics will dramatically increase load losses (DC and eddy currents) but have very little effect on no-load losses. Various types of transformer connections are available on request including polygon or double-zigzag connections. High or low value coupling coefficient and phase shifting options are also available.



Technical Characteristics

| | |
|------------------------|-------------------------------|
| Rated power | Up to 80 MVA |
| Rated voltage | Various - please consult us |
| Phases | Three-phase unit |
| Rated frequency | 50 Hz or 60 Hz |
| Type of cooling | ONAN, ONAF (other on request) |

How to Avoid Harmonic Effects on the Transformer

What are the negative effects on the transformer due to harmonics? Harmonic distortion will result in an increase of transformer stray/eddy current losses in the windings and steel parts due to harmonic current components. The net effect of harmonic distortion is an increase in the operational temperature and a consequential reduction in service life. Taking into account the power needs of the equipment fed by the transformer and especially the harmonics generated by the rectifier or the speed drive, our experts will dimension the transformer to the exact size using CAD programming. These programs have been created based on our long term experience and are constantly evolving and being improved.

As a result, you can:

- improve your power quality
- improve the transformer's and surrounding equipment's life expectancy
- minimise space requirements.



Minera R Transformer

Minera E - Earthing Transformers

Up to 15 kA and 72 kV

Applications

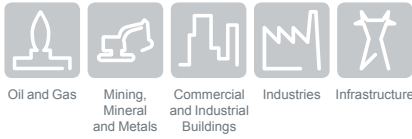

Oil and Gas Mining, Mineral and Metals Commercial and Industrial Buildings Industries Infrastructure



Minera E Transformer

Schneider Electric’s Minera-E is recognized for its reinforced, rugged mechanical design that supports short circuit conditions while protecting the network.

Minera E earthing transformers and coils have been designed to protect your system against phase-earth fault currents for the given fault time duration. If an earth fault occurs on one line of an insulated system - usually one fed by a delta-connected main transformer winding with no return path available for the earth fault current and no current flow - the system will continue to operate, but the other two lines will rise in voltage and both the transformer and the system will suffer from over-stressed insulation.

Minera E complies with the specified international standards required including IEC 60070 Part 6, and relevant IEE and EN/VDE standards.

Technical Characteristics

| | |
|-------------------------|---|
| Rated power | Up to 15 kA (earth fault current) |
| Rated voltage | Up to 72 kV |
| Phases | Three-phase unit |
| Rated frequency | 50 Hz or 60 Hz |
| Type of cooling | ONAN |
| Other (optional) | Oil temperature indicator, integrated safety detector, pressure relief device, winding temperature indicator, marshalling box and wheels, limiting dimensions, fittings and paint systems, are available on request |

Minera PV Transformers for Photovoltaic Systems

Up to 1600 kVA and 36 kV

Applications



Solar

Schneider Electric developed transformers specially designed for grid connected photovoltaic systems. These transformers are designed according to any single customer requirements regarding voltage, power, low losses, sound level, climate and more. Special attention to people and environmental safety issues is always considered. In large PV installations, multiple inverters paralleled to the PV arrays are directly connected to one or more medium-voltage transformers. Schneider Electric's offer of three-winding transformers can reduce costs without compromising any of the transformer functions. The transformer's primary voltage is at the low voltage side and the secondary is at the medium voltage side.



Technical Characteristics

| | |
|------------------------|---|
| Rated power | Up to 1600 kVA |
| Rated voltage | Up to 36 kV |
| Phases | Three-phase unit |
| Rated frequency | 50 Hz or 60 Hz |
| Type of cooling | ONAN or ONAF |
| Other | Protection relays on the filing plug, liquid retention tank |



Minera PV Transformer

Photovoltaic Systems

Minera PV transformers are the ideal solution for photovoltaic systems. The technology used along with the appropriate sizing of the core, the framework and the high quality materials results in the most suitable product in terms of quality, reliability, efficiency and cost effectiveness. Three-winding transformer features include:

- galvanic isolation between the solar inverter and the feeding network
- voltage step-up from the inverter output to the MV feeding network
- wound magnetic core for:
 - standard or low losses
 - minimum sound levels and low inrush current.

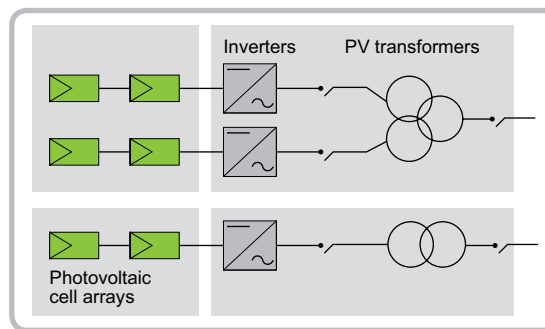

Diagram for photovoltaic systems

Siltrim - Compact Size Transformers

Up to 3.3 MVA and 36 kV

Applications



Oil and Gas

Utilities

Wind



Siltrim



Schneider Electric has designed a very compact distribution transformer answering your technical requirements and adapted to fit into reduced spaces.

Siltrim's patented design allows it to remain cool despite its extremely compact size. Siltrim is specifically built for our customers' complex mechanical and electrical environments and can be installed in the harshest environmental locations.

It has been tested for an extremely high overvoltage level and is equipped with a pressure-relief device as an added safety measure against explosion. It offers lower winding hotspot temperatures resulting in a longer working life with high availability and proven reliability.

Technical Characteristics

| | |
|-------------------------|------------------|
| Rated power | Up to 3.3 MVA |
| Rated voltage | Up to 36 kV |
| Phases | Three-phase unit |
| Rated frequency | 50 Hz or 60 Hz |
| Type of cooling | ONAN |
| Other (optional) | On request |

Siltrim, for extra power without extra heat!

Siltrim's high performance level (higher efficiency, low temperature rise, fire resistance) combined with its compactness is obtained by using an excellent fire resistant and heat dissipating dielectric liquid. Siltrim can handle high harmonics, environmental and overload conditions.

- Long life cycle
- Compact
- Increased fire resistance
- Designed for high harmonic environments and overload conditions
- Low heat dissipation
- Optional vibration pads for additional resistance
- Near-zero maintenance, recyclable.

Vegeta - Biodegradable vegetable oil Transformers

Up to 25 MVA and 72.5 kV

Applications



Vegeta

With natural ester-based biodegradable vegetable oil as the dielectric medium, Vegeta oil-immersed transformer becomes one of the most environment friendly product available on the market today.

The vegetable oil is specifically formulated to be safe for people and the environment. It is made of food-grade seeds and is not listed as hazardous by international authorities such as EPA (Environmental Protection Agency) and OSHA (Occupational Safety and Healthy Administration).

This technology is biodegradable and non-toxic with a superior back-to-nature recycling rate of more than 99%. Vegeta has been assigned a water hazard classification of zero, which means it is also eligible for use in areas where stringent environmental restrictions apply (water points, fields and forests).

Technical Characteristics

| | |
|------------------------|------------------------------|
| Rated power | 50 kVA to 25 MVA |
| Rated voltage | 72.5 kV |
| Phases | One or three-phase unit |
| Rated frequency | 50 Hz or 60 Hz |
| Type of cooling | ONAN, ONAF, ODAF, ODAN, ODWF |

Environmentally friendly and adapted to sensitive area

- An active eco-citizen approach
- No risk for people's health
- Enhanced fire behaviour
- Increased overload withstand.

Vegetable oil has a better environmental and health profile than conventional mineral oil.

Vegetable oil has the advantage of being biodegradable, so oil spill management solutions are made easier. Its unique ability to absorb moisture contained in aging paper can extend insulation life by a factor of as much as five.

It also chemically helps to prevent long cellulose paper molecules from scission (i.e. aging) due to heat exposure. These properties can result in an increase of overloading capability and longer transformer insulation life. The results are lower lifecycle costs and better use of your assets.

Imprego & Imprego AT

Up to 400 kVA and 1.1 kV

Applications



Oil and Gas Infrastructure Industries Marine Security network



LV/LV Special transformer

Imprego

The range of LV/LV transformers are available in ratings up to 400 kVA. Imprego transformers are used to change the earthing system, isolate network disturbances, change the voltage and to supply power and ensure personal safety or equipment maintenance.

Technical Characteristics

| | |
|------------------------|---|
| Rated power | Up to 400 kVA (for higher ratings, please consult us) |
| Rated voltage | 400/400 V or 400/231 V and up to 1.1 kV |
| Phases | Single phase, three-phase |
| Rated frequency | 50 Hz or 60 Hz |
| Other | Electrostatic shield between the primary and the secondary connected to the earth, completely separate windings; covers may be purchased later as accessories |

Applications



Oil and Gas Infrastructure Health Care Marine



Imprego AT

Dry-Type Autotransformer

The range of autotransformers are available in ratings up to 400 kVA. They are used to adapt the network voltage without isolating the installation from electrical disturbances and they help gain in size compared to a transformer with the same power.

Technical Characteristics

| | |
|------------------------|---|
| Rated power | Up to 400 kVA (for higher ratings, please consult us) |
| Rated voltage | 231/400 V or 400/231 V and up to 1.1 kV |
| Phases | Three-phase |
| Rated frequency | 50 Hz or 60 Hz |
| Other | Star/star coupling with neutral |

R-Cool - Air Conditioned Special Dry-Type Dry-Type Transformers up to 3150 kVA and 36 kV

Applications



R-Cool dry-type transformer is an air conditioned special dry-type transformer, designed to achieve high IP ratings and efficient cooling, which can not be reached with conventional enclosures and cooling. It is now possible to utilise dry-type transformers in extreme temperatures and dust; indoor or outdoor or 100 per cent humidity without the need for filters or any other disposal materials. External air, water or other coolant is not required at site since R-Cool is a complete stand-alone solution; it simply needs to be powered up to operate.

The R-Cool dry-type transformer is equipped with a transformer enclosure and a cooling compartment. Due to the size of the transformer, cooling compartments can be single or dual. Enclosure and cooling compartments are manufactured with 2 mm S235 sheet steel. Outdoor units are also zinc coated to achieve higher corrosion resistance.



Technical Characteristics

| | |
|------------------------|-------------------------------|
| Rated power | Up to 3150 kVA |
| Rated voltage | Up to 36 kV |
| Phases | Three-phase unit |
| Rated frequency | 50 Hz or 60 Hz |
| Type of cooling | Two independent cooling flows |



R-Cool Dry-Type Transformer

R-Cool Cooling System

The purpose of R-Cool systems is to transfer heat from the evaporator to the condenser by the refrigerant transfer. Basically, there are two independent flows in the system. Condenser fans use ambient air to cool down the condenser. This flow is completely separated from enclosure so the transformer is isolated from ambient conditions. R-Cool system does not only cool transformer coils like conventional cooling systems, but provides the desired environment by creating and controlling the ambient inside the transformer enclosure. The R-Cool system provides a homogenous and stable environment for the entire unit, while the conventionally cooled dry-type transformers only cool down the transformer coils.

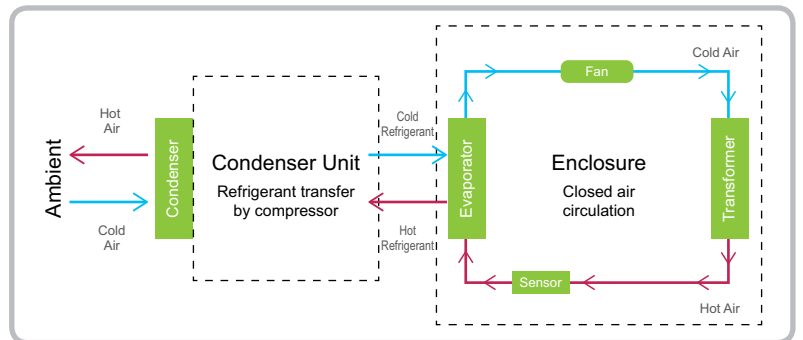

R-Cool System

Three-Phase Common Transformer Vector Groups

| Phasor symbols | Terminal markings and phase displacement diagram of induced voltages | | Winding connections |
|---|--|------------|---------------------|
| | HV winding | LV winding | |
| Dy1 | | | |
| Yd1 | | | |
| Phase displacement = - 30° Clock-hour figure = 1 | | | |
| Dy11 | | | |
| Yd11 | | | |
| Phase displacement = 30° Clock-hour figure = 11 | | | |

Calculation of Transformer Efficiency

Let us assume that a three-phase transformer, 630 kVA, 20/0.4 kV, has 1200 W no-load losses and 9300 W load losses. Determine the transformer efficiency at full load (case 1) and at 75% load (case 2) for power factor 1.0 and 0.8.

Case 1: full load

The efficiency at full load and for power factor equal to 1.0 (cos φ = 1.0) is calculated as follows:

$$\eta_1 = \frac{S \cos \varphi}{S \cos \varphi + \text{NLL} + \text{LL} (S/S_B)^2} = \frac{630000 \cdot 1.0}{630000 \cdot 1.0 + 1200 + 9300 \cdot (1.0)^2} = 0.9836 = 98.36\%$$

The efficiency at full load and cos φ = 0.8 is:

$$\eta_2 = \frac{630000 \cdot 0.8}{630000 \cdot 0.8 + 1200 + 9300 \cdot (1.0)^2} = 97.96\%$$

Case 2: load 75%

The efficiency at load 75% and cos φ = 1.0 is:

$$\eta_3 = \frac{472500 \cdot 1.0}{472500 \cdot 1.0 + 1200 + 9300 \cdot (0.75)^2} = 98.66\%$$

The efficiency at load 75% and cos φ = 0.8 is:

$$\eta_4 = \frac{472500 \cdot 0.8}{472500 \cdot 0.8 + 1200 + 9300 \cdot (0.75)^2} = 98.33\%$$

Calculation of Transformer Efficiency

Let us assume that a three-phase transformer, 630 kVA, 20/0.4 kV, has 9300 W load losses and 6% short-circuit impedance. Determine the voltage drop at full load (case 1) and at 75% load (case 2) for power factor 1.0 and 0.8.

The voltage drop is given by the following equation:

$$U_{\text{drop}} = \frac{S}{S_B} (e_r \cos \varphi + e_x \sin \varphi) + \frac{1}{2} \frac{1}{100} \left(\frac{S}{S_B}\right)^2 (e_r \sin \varphi + e_x \cos \varphi)^2$$

where:

$$e_r = \frac{\text{LL}}{S_B} = \frac{9300}{630000} = 0.014762 = 1.4762\% \text{ and } e_x = \sqrt{U_k^2 - e_r^2} = \sqrt{0.06^2 - 0.014762^2} = 0.05816 = 5.816\%$$

Case 1: full load

For cos φ = 1, sin φ = 0.

$$U_{\text{drop}} = \frac{S}{S_B} (e_r \cos \varphi + e_x \sin \varphi) + \frac{1}{2} \frac{1}{100} \left(\frac{S}{S_B}\right)^2 (e_r \sin \varphi + e_x \cos \varphi)^2 = (1.0) \cdot (1.4762 \cdot 1 + 5.816 \cdot 0) + \frac{1}{2} \frac{1}{100} (1.0)^2 (1.4762 \cdot 0 + 5.816 \cdot 1)^2 = 1.645\%$$

For cos φ = 0.8, sin φ = √(1 - (cos φ)²) = 0.6.

$$U_{\text{drop}} = (1.0) \cdot (1.4762 \cdot 0.8 + 5.816 \cdot 0.6) + \frac{1}{2} \frac{1}{100} (1.0)^2 (1.4762 \cdot 0.6 + 5.816 \cdot 0.8)^2 = 4.741\%$$

Case 2: load 75%

For cos φ = 1, the voltage drop is calculated as follows:

$$U_{\text{drop}} = (0.75) \cdot (1.4762 \cdot 1 + 5.816 \cdot 0) + \frac{1}{2} \frac{1}{100} (0.75)^2 (1.4762 \cdot 0 + 5.816 \cdot 1)^2 = 1.202\%$$

For cos φ = 0.8, the voltage drop is:

$$U_{\text{drop}} = (0.75) \cdot (1.4762 \cdot 0.8 + 5.816 \cdot 0.6) + \frac{1}{2} \frac{1}{100} (0.75)^2 (1.4762 \cdot 0.6 + 5.816 \cdot 0.8)^2 = 3.543\%$$

Transformer Calculations

Parallel Operation and Transformer Selection

Parallel Operation of Transformers

Let us assume that three transformers operate in parallel.
 The first transformer has 800 kVA rated power and 4.4% short-circuit impedance.
 The rated power and the short-circuit impedance of the other two transformers is 500 kVA and 4.8%, and 315 kVA and 4.0%, respectively.
 Calculate the maximum total load of the three transformers.

Among the three transformers, the third transformer has the minimum short-circuit impedance,

$$\text{i.e } U_{k,\min} = 4.0\%$$

The load of transformer 1 is:

$$P_{n,1} = P_1 \frac{U_{k,\min}}{U_{k,1}} = 800 \frac{4}{4.4} = 728 \text{ kVA}$$

The load of transformer 2 is:

$$P_{n,2} = P_2 \frac{U_{k,\min}}{U_{k,2}} = 500 \frac{4}{4.8} = 417 \text{ kVA}$$

The load of transformer 3 is:

$$P_{n,3} = P_3 \frac{U_{k,\min}}{U_{k,3}} = 315 \frac{4}{4} = 315 \text{ kVA}$$

The maximum total load of the three transformers is:

$$P_{\text{tot}} = P_{n,1} + P_{n,2} + P_{n,3} = 728 + 417 + 315 = 1460 \text{ kVA}$$

The three transformers have total installed power:

$$P = P_1 + P_2 + P_3 = 800 + 500 + 315 = 1615 \text{ kVA}$$

From the above, it is concluded that the maximum total load (1460 kVA) represents the 90.4% of the total installed power (1615 kVA).

It should be noted that, in order the maximum total load to be equal to the total installed power, the transformers must have the same short-circuit impedance.

Transformer Calculations

Air Resistance and Cross-Section Input and Output Openings

When the transformer is going to be installed inside an electrical room (indoor installation), particular attention should be paid to the calculation of the dimensions of the installation area as well as to the ventilation of the installation room. The ventilation of the electrical room influences the cooling, and consequently, the transformer's life. The distance between the walls of the room and the transformer end points must be from 50 to 60 cm.

Calculation of air resistance

For the calculation of the dimensions of the openings for the input and output of air in the electrical room, the calculation of the air resistance is required.

For the air resistance, the symbol W is used in the sequel. The value of the air resistance depends on the existence or not of lattices, meshes and venetian blinds.

If there are no lattices, meshes and venetian blinds in the input and output openings of the air, then the minimum air resistance is:

$$W_{\min} = 4$$

For each lattice, the value $W_L = 1$ is added to the value of W_{\min} .

For each mesh, the value $W_M = 1.5$ is added to the value of W_{\min} .

For each adjustable venetian blind, the value of $W_V = 3$ is added to the value of W_{\min} .

For example, for a transformer installation room with two meshes (one in the input and one in the output of air), the minimum air resistance is:

$$W = W_{\min} + 2 W_M = 4 + 2 \times 1.5 = 7$$

The lowest possible temperature in the transformer electrical room is achieved with the following ways:

- the opening for the output of the hot air is placed in the highest possible location,
- the opening for the input of the cold air is placed in the lowest possible location.

Calculation of cross-section area of the input and output openings

The cross-section area of the opening for the input of air, $F1$ (m^2), is calculated by the following formula:

$$F1 = \frac{4.25}{100} V \sqrt{\frac{10^4 W}{H t^3}}$$

where V is the total transformer losses (kW), W is the air resistance, H is the height (m) of the opening for the output of air from the horizontal symmetry axis of transformer (see diagram), and t is the temperature rise ($^{\circ}C$) of the transformer room.

The cross-section area of the opening for the output of air, $F2$ (m^2), should be 10% to 15% larger than the cross-section area of the opening for the input of air ($F1$).

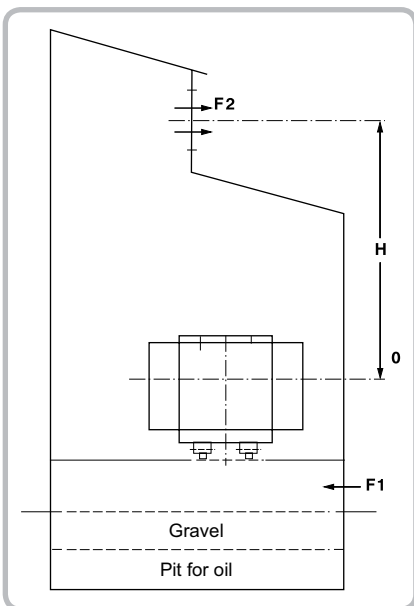

Dimensions of transformer installation room

Transformer Calculations

Overloading

Ambient Temperature

The rated power of the transformer is typically calculated for the following conditions:

- maximum ambient temperature of 40°C
- average daily ambient temperature of 30°C
- average annual ambient temperature of 20°C.

On request, transformers operating under different ambient temperature conditions can be produced.

Overloading

The rated overloading of transformer depends on the transformer's previous load or the corresponding oil temperature at the beginning of the overloading. Examples of the permissible duration and the respective levels of the acceptable overloadings are shown below.

For example, if the transformer is loaded with 50% of its rated power continuously, then the transformer can be overloaded to 150% of its rated power for 15 minutes or to 120% of its rated power for 90 minutes.

| Previous continuous loading % of rated power | Oil temperature °C | Duration (min.) of overloading for specific levels of overloading (% of rated power) | | | | |
|---|-----------------------|--|----------|----------|----------|----------|
| | | 10% min. | 20% min. | 30% min. | 40% min. | 50% min. |
| 50 | 55 | 180 | 90 | 60 | 30 | 15 |
| 75 | 68 | 120 | 60 | 30 | 15 | 8 |
| 90 | 78 | 60 | 30 | 15 | 8 | 4 |

Permissible duration and level of acceptable overloading.

It should also be noted that the oil temperature is not a safe measure for the winding temperature, since the time constant of the oil is 2 to 4 hours, while the time constant of the winding is 2 to 6 minutes. Therefore, the determination of the permissible duration of the overloading must be done very carefully, since there is a danger of the winding temperature exceeding the critical temperature of 105°C, without being visible by the oil temperature.

What is it?

EcoDesign is a European Union regulation which came into force in 11th June 2014 in the 28 countries of European Union.

This new legislation imposes, within the EU, the maximum level of losses for transformers placed in the market or put into service from 1st July 2015 and purchased after 11th June 2014.

After the date of entry into force, manufacturers should not engage in new framework contracts for transformers with energy efficiency specifications below the minimum requirements outlined in the regulation.

Framework contracts signed before 11th June 2014 can go on until the end date, even with deliveries after 1st July 2015.

Why this regulation?

- EcoDesign aims for two major objectives on the Transformer product:
 - Reduce electrical losses (1st step in 2015/ 2nd step in 2021)
 - Clarify and make more visible indication of performance.
- Harmonisation of maximum loss levels in the European Union
- Efficiency request on medium power transformers for the 1st time.

Which transformers are impacted?

The following equipments are impacted:

- All transformers exceeding 1 kVA and with the high voltage higher than 1 kV
- Oil Distribution and Dry-type transformers (≤ 3150 kVA) with high voltage winding above 1.1 kV up to and up to 36 kV
- Medium power and Large power transformers > 3150 kVA and higher than 36 kV (limited to 10 MVA 36 kV for Dry-type Transformers).

Special transformers are not impacted by this regulation (please refer to restriction list for details).

What are the losses levels authorized?

For Oil Distribution and Dry-type transformers (≤ 3150 kVA):

- Losses levels to be applied (reference of MV ≤ 24 kV and LV ≤ 1.1 kV).

| Maximum Loss Levels | Rated power | Tier 1: from 01.07.2015 | Tier 2: from 01.07.2021 (Values subject to further validation) |
|---------------------|----------------------|-------------------------|---|
| Pole-mounted | 25, 50 and 100 kVA | AoCk | AoBk |
| | 160 kVA | CoCk+32% | Co-10% Ck+32% |
| | 200, 250 and 315 kVA | CoCk | BoBk |
| ODT | ≤ 1000 kVA | AoCk | Ao-10% Ak |
| | > 1000 kVA | AoBk | |
| CRT | ≤ 630 kVA | AoBk | |
| | > 630 kVA | AoAk | |

- ODT and CRT not covered by reference transformers:
(additional losses allowed compared to standard losses ranges)

| Other requirement | Impact on no load losses compared to standard losses table | Impact on load losses compared to standard losses table |
|--|---|--|
| MV insulation level ≤ 24 kV LV insulation level > 1.1 kV | 10% | 10% |
| MV insulation level = 36 kV LV insulation level ≤ 1.1 kV | 15% | 10% |
| MV insulation level = 36 kV LV insulation level > 1.1 kV | 20% | 15% |
| Dual voltage on MV winding and 85% power limitation on higher MV voltage | No impact | No impact |
| Dual voltage on MV winding and 85% power limitation on higher LV voltage | No impact | No impact |
| Dual voltage on one winding (MV or LV) and full power on all voltages considered | 15% | 10% |
| Dual voltage on both windings (MV and LV) | 20% | 20% |
| Transformers with tappings for operation while being energized (such as Voltage Regulation Distribution Transformers) | 20% (reduced to +10% in 01-07-2021) | 5% |

Ex: ODT 630 kVA, 33 kV - 410 V
max losses to be considered: A0+15% - Ck +10%

EcoDesign Regulation EU 548-2014

- Medium power and power transformers: Level of Peak Efficiency (Mix of load losses and no load losses) for transformers > 3150 kVA (limited to 10 MVA 36 kV for Dry-type Transformers)
 - No losses levels imposed but minimum PEI (Peak Efficiency Index)
 - PEI corresponds to:
 - the maximum efficiency of the transformer
 - Ratio between the no load losses and losses.

$$PEI = 1 - \frac{2(P_0 + P_{co})}{S_r \sqrt{\frac{P_0 + P_{co}}{P_k}}}$$

P₀: No load losses
P_k: Load losses
S_r: Rated power
P_{co}: Losses of ventilation

| Sr (MVA) | PEI - T1 (%) | PEI - T2 (%) |
|----------|--------------|--------------|
| ≤ 4 | 99.465 | 99.532 |
| 5 | 99.483 | 99.548 |
| 6.3 | 99.510 | 99.571 |
| 8 | 99.535 | 99.593 |
| 10 | 99.56 | 99.615 |
| 12.5 | 99.588 | 99.640 |
| 16 | 99.615 | 99.663 |
| 20 | 99.639 | 99.684 |
| 25 | 99.657 | 99.700 |
| 31.5 | 99.671 | 99.712 |
| 40 | 99.684 | 99.724 |
| 50 | 99.696 | 99.734 |
| 63 | 99.709 | 99.745 |
| 80 | 99.723 | 99.758 |
| ≥ 100 | 99.737 | 99.770 |

The values given are Maximal value → no more tolerances on design considered:

| Measured parameter | Before | With new regulation |
|--------------------|--------|---------------------|
| Load losses | +15% | 0% |
| No load losses | +15% | 0% |
| Total losses | +10% | 0% |

Reduced operation costs and then improved Total Cost of Ownership of the product.

As a global energy efficiency leader Schneider Electric will support you providing a fully compliant Transformer!

Total Cost of Ownership

A pragmatic way to choose the right transformer

When purchasing a transformer and even more when comparing two different solutions, the right choice is driven by economical analysis of the equipments. Total Cost of Ownership, giving transformers cost of use along their lifespan including purchasing, operating and maintaining costs.

Basically some simplification can be done when comparing two different transformers with the same technology: installation, maintenance and decommissioning will generate the same cost levels and then be put out of the comparison.

The calculation has to take into consideration the evolution of the cost of energy during transformer lifespan. This is the interest rate to be considered as given below.

The simplified calculation formula of the Total cost of ownership becomes the following:

Total Cost of Ownership = Purchasing Price + No Load Losses Cost + Load Losses Cost

With:

No Load Losses Cost: $NLLC = (1+i)^n - 1 / i(1+i)^n * C * Time$

Load Losses Cost: $LLC = (1+i)^n - 1 / i(1+i)^n * C * Time * Load\ factor^2$

Where:

i: interest rate [%/year]

n: lifetime [years]

C: kWh price [USD/kWh]

Time: number of hours in a year [h/year] = 8760

Load factor: average load of the transformer during its life time

Total Cost of Ownership calculation is a key to consider operating costs when purchasing a new Transformer.
[Visit our TCO online tool for more details!](#)

Schneider Electric Industries SAS

35, rue Joseph Monier
CS 30323
92506 Rueil Malmaison Cedex
France

RCS Nanterre 954 503 439
Capital social 896 313 776 €
www.schneider-electric.com

As standards, specifications and designs change from time to time, please ask for confirmation of the information given in this publication.

Design, publication: Schneider Electric Industries SAS
Photos: Schneider Electric Industries SAS, © Fotolia
Printing:



 This document has been printed on ecological paper