



# PowerLogic System

Energy management, revenue metering, and power quality monitoring



[www.schneider-electric.us/powermonitoring](http://www.schneider-electric.us/powermonitoring)

Life Is On



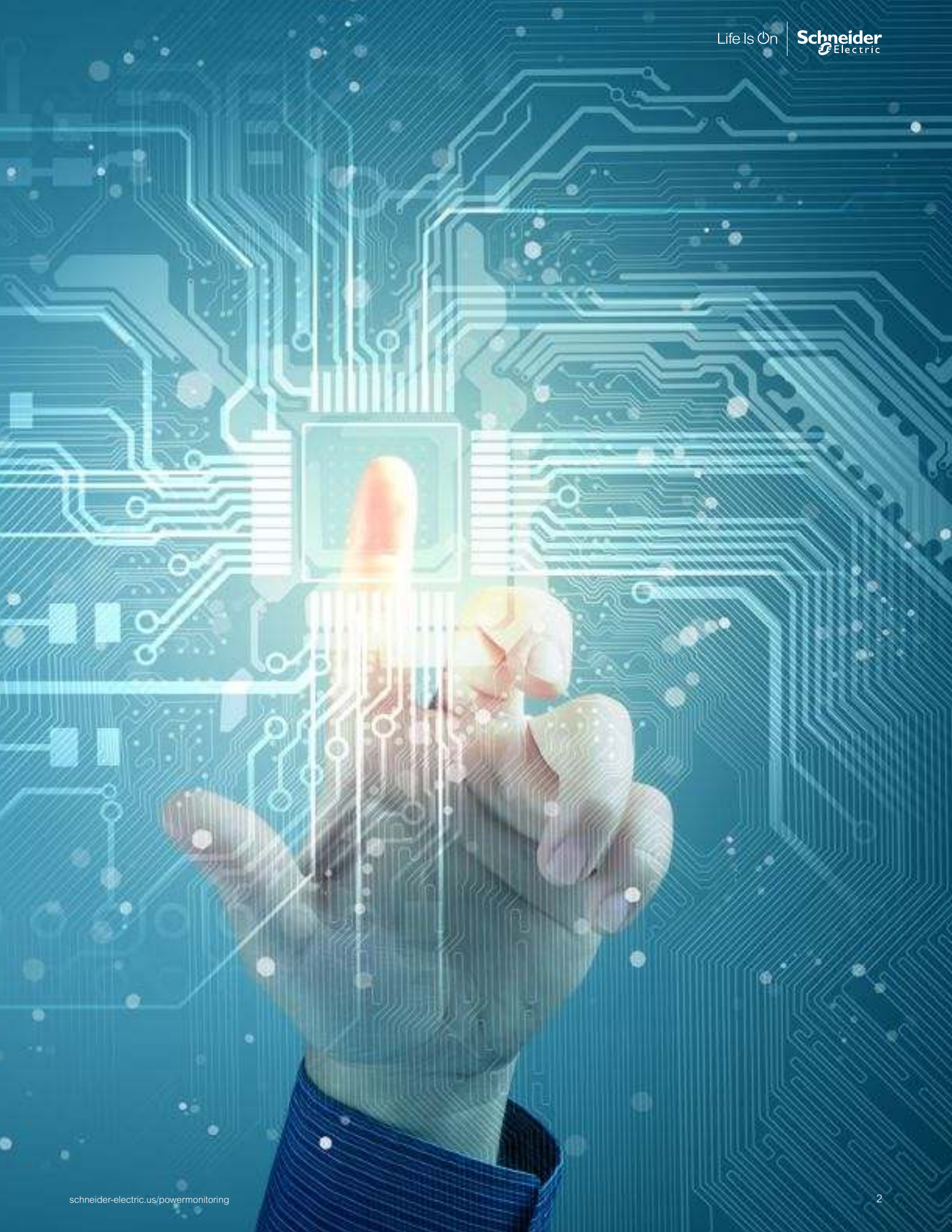

The Power of PowerLogic	4
Basic energy metering PowerLogic energy meters and IEM3000 series	14
Basic multi-function metering PM3000 series, PM5000 series, ION6200, EM3500, and EM4200 series	36
Intermediate metering PM8000 series	80
Advanced metering ION7550/ION7650 series, CM4000T, and ION9000	94
Advanced utility metering ION7400 and ION8650	128
Multi-circuit metering BCPM, EM4900, EM4000, and EM4800	152
Communications Link150, Com'X 210, Com'X 510, and ION7550 RTU	190
Monitoring software EcoStruxure™ power management software	216

# The Power of PowerLogic

Schneider Electric believes every business can increase productivity while consuming less and achieving energy savings of 10–30%.

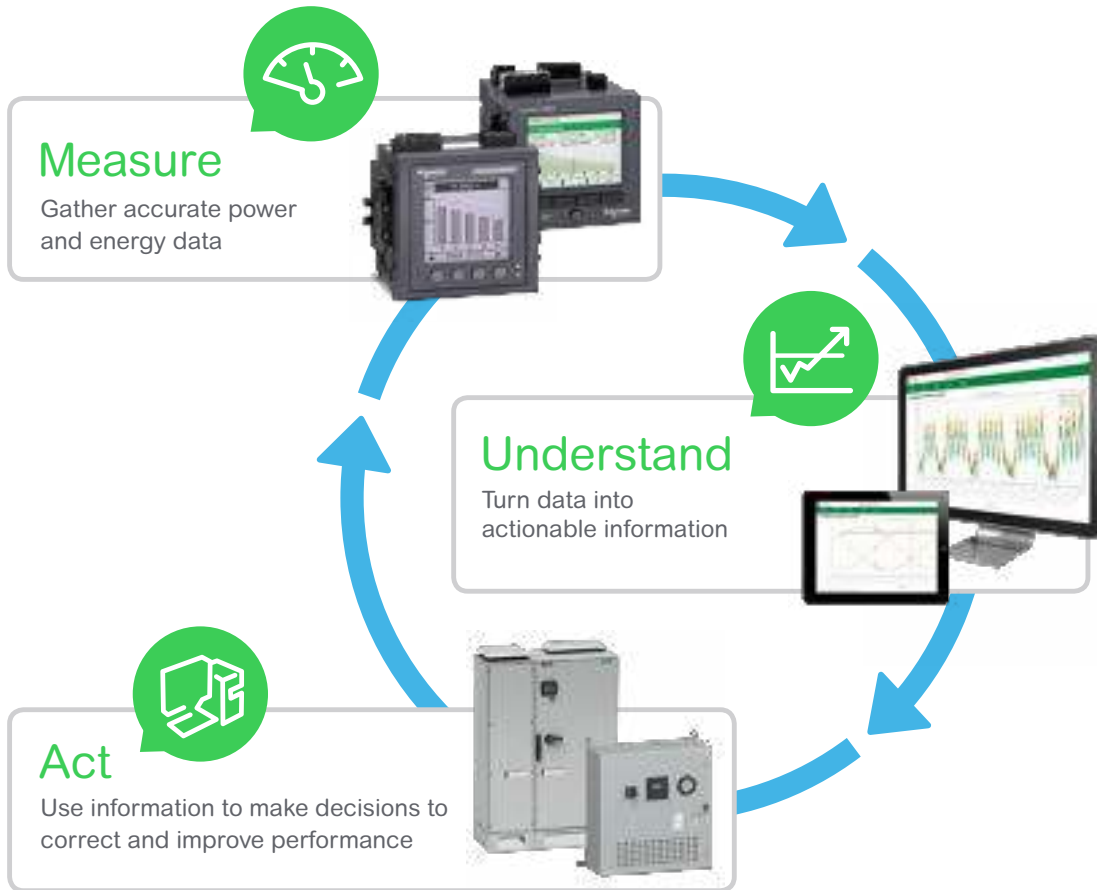

PowerLogic™ technology forms one part of your total energy management solution from Schneider Electric. As the global energy management specialist, we offer end-to-end power, building and process management solutions that help you optimize energy use and costs, improve performance, enhance comfort and safety, and deliver uninterrupted service while taking responsible care of our planet.

Our expert services can help you audit your energy use and build your energy action plan. From power factor correction systems, harmonic filtering and variable speed drives to HVAC and lighting controls, we offer a complete range of energy-efficient technologies.

Saving energy reduces costs and pollution, but you need the tools to uncover all opportunities, avoid risks, track progress against goals, and verify success. Schneider Electric provides these tools via the world's most advanced energy intelligence technology — PowerLogic.

A PowerLogic system of meters, software, and power quality solutions help manage all energy assets, every second of the day. A PowerLogic system enables all stakeholders, from CEO to facility and engineering managers, to respond quickly to potential problems and manage energy in financial and environmental terms.

PowerLogic technology delivers the key performance indicators and analytics that you need to strategically balance emissions, efficiency, reliability, and cost.

# Gain energy insight and control with PowerLogic systems

## Cutting-edge technology to increase profitability

PowerLogic technology converts the complex dynamics governing the relationship between power generation and distribution on the utility side, and energy consumption and cost and reliability on the consumer side, into timely, easily understood information. Businesses can use this powerful data to improve tactical actions and strategic decision-making.

From a single facility to an entire enterprise, PowerLogic meters monitor key distribution points 24 hours a day. Whether from generators, substations, service entrances, mains, feeders, loads, or third-party equipment and systems, PowerLogic technology tracks, records, and reports all real-time conditions and historical performance data. Intuitive web-based interfaces give stakeholders access to this data as well as advanced analytics, alarm annunciation, and control capabilities. It supports comprehensive energy-management programs by tracking performance and empowering you to make effective decisions.

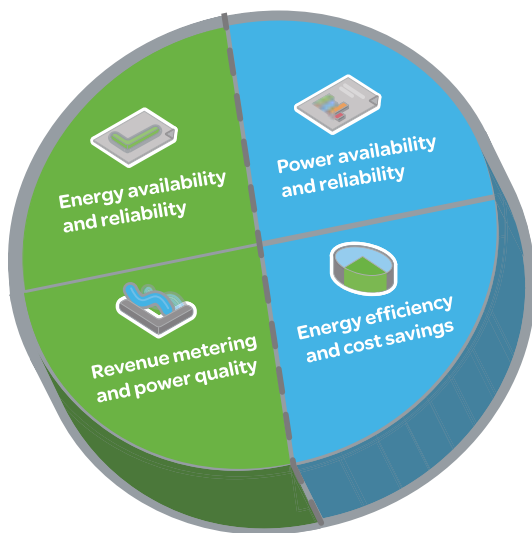

### Supply

Energy availability and reliability

- Improve T&D network reliability
- Enhance substation automation
- Maximize the use of your existing infrastructure

Revenue metering and power quality

- Maximize metering accuracy at all interchange points
- Verify compliance with new power quality standards
- Analyze and isolate the source of power quality problems

### Demand

Power availability and reliability

- Validate that power quality complies with the energy contract
- Identify power quality issues and fix them quickly with reliable mitigation solutions
- Improve response to power-related problems
- Leverage existing infrastructure capacity and avoid over-building
- Support proactive maintenance to prolong asset life

Energy efficiency and cost savings

- Measure efficiency, reveal opportunities, and verify savings
- Manage greenhouse gas emissions
- Allocate energy costs to departments or processes
- Reduce peak-demand and power-factor penalties
- Enable participation in load curtailment programs (e.g., demand response)
- Strengthen rate negotiation with energy suppliers
- Identify billing discrepancies
- Sub-bill tenants for energy costs

# EcoStruxure

## Innovation At Every Level

### IoT-enabled solutions that drive operational and energy efficiency

PowerLogic products are a part of EcoStruxure Power; EcoStruxure™ is Schneider Electric's open, interoperable, IoT-enabled system architecture and platform.

EcoStruxure delivers enhanced value around safety, reliability, efficiency, sustainability, and connectivity for our customers.

EcoStruxure leverages advancements in IoT, mobility, sensing, cloud, analytics, and cybersecurity to deliver Innovation at Every Level including connected products, edge control, and apps, analytics, and services. EcoStruxure has been deployed in 450,000+ installations, with the support of 9,000 system integrators, connecting over one billion devices.

### One EcoStruxure architecture, serving 4 End Markets with 6 Domains of Expertise

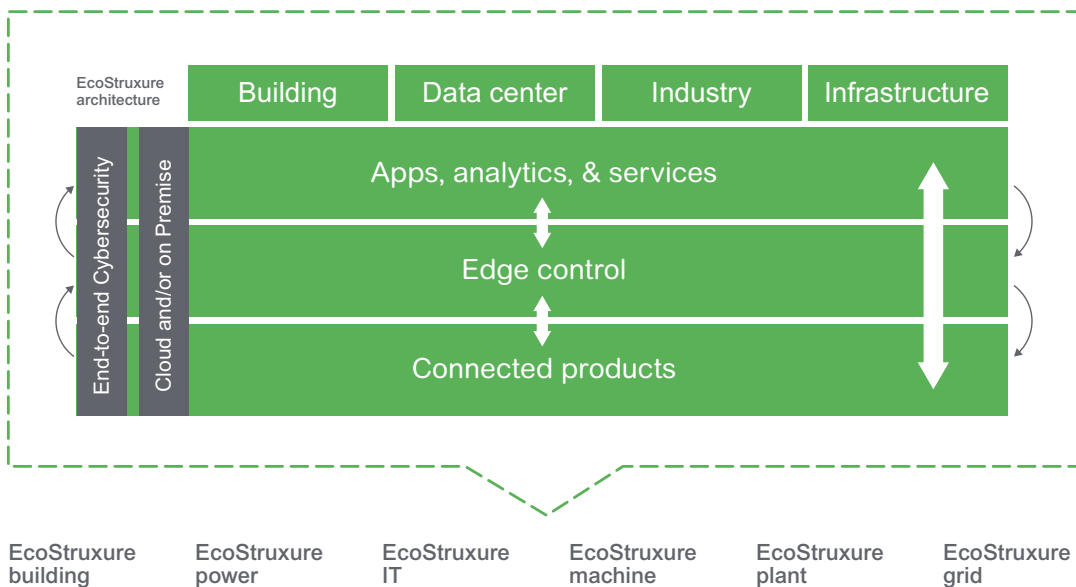

#### Connected products

The Internet of Things starts with the best things. Our IoT-enabled best-in-class connected products include breakers, drives, UPS, relays, sensors, and more. Devices with embedded intelligence drive better decision-making throughout operations.

#### Edge control

Mission-critical scenarios can be unpredictable, so control of devices at the edge of the IoT network is a must. This essential capability provides real-time solutions that enable local control at the edge, protecting safety and uptime.

#### Apps, analytics, & services

Interoperability is imperative to supporting the diverse hardware and systems in building, data center, industry, and grid environments. EcoStruxure enables a breadth of agnostic apps, analytics, & services for seamless enterprise integration.

Find out more about EcoStruxure

[schneider-electric.us/ecostruxure](https://schneider-electric.us/ecostruxure)

# Market segments



## Industry

PowerLogic technology gives industry professionals the energy intelligence and control to support strategic decisions and establish best energy practices. It will help you reduce operational costs and meet new emissions standards without compromising production.

Key points are monitored throughout your power distribution, building, and backup systems. Enterprise-level software helps you maximize the use of your existing energy assets, increase efficiency, and avoid demand or power-factor penalties. You can uncover hidden power problems that can shorten equipment life or cause costly downtime.

- Cost allocation
- Procurement optimization
- Power factor correction



## Utilities

Whether you generate, transmit, or distribute electricity, more stakeholders need shared access to timely, accurate energy data from more exchange points and you need to maintain power availability and reduce price volatility in the face of rising demand and transmission congestion. A PowerLogic system helps you meet all of these challenges by:

- Metering all key interchange points with absolute accuracy
- Improving the quality of power delivered to your customers
- Assuring network and equipment reliability and efficiency

From advanced energy and power quality metering systems to enterprise-level analytic software, PowerLogic systems deliver business-critical information that conventional metering, SCADA, and billing systems cannot. Gain the energy intelligence and control needed to track performance, stay informed of critical conditions, and make strategic decisions. It will help you increase reliability, maximize the use of resources, and improve service.

- Revenue metering
- Power quality monitoring
- Power availability and reliability



## Buildings

Cut energy and maintenance costs without affecting the comfort or productivity of your tenants, employees, students, patients, or customers. A PowerLogic system will track all utilities and equipment conditions, and enterprise-level software will help you analyze and improve electrical reliability.

You can forecast energy requirements, optimize multi-site contracts, and accurately allocate or sub-bill costs. Find and sustain energy savings, reduce emissions, and meet “green” building standards in order to increase asset value and attract or retain tenants.

- Tenant sub-billing
- Cost allocation
- Energy efficiency/benchmarking
- Procurement optimization
- Power availability
- Demand response/load curtailment



## Critical infrastructure

PowerLogic technology helps keep your systems operating continuously and securely with an economical supply of energy. Whether you manage data, communication, transportation, or environmental services, minimizing the risk of power-related downtime and reducing costs is a priority.

A PowerLogic system monitors all power systems, accurately tracks energy consumption, and allows you to identify and fix power quality issues. Enterprise-level software delivers insightful diagnostics and metrics to help verify the reliability of your backup systems and maximize the use of existing capacity to defer new capital investments. You can also reveal energy inefficiencies and strengthen energy procurement across multiple sites.

- Infrastructure optimization
- Power quality analysis compliance
- Alarming and event notification
- Energy efficiency
- Cost allocation
- Procurement optimization

# Panorama of the PowerLogic range

**Basic energy metering** | **Basic multi-function metering**



Name	PowerLogic energy meter	iEM3000 series	PM3000 series	EM4200	ION6200	EM3500
Function	Kilowatt-hour meters 1% including CTs	Kilowatt-hour meters	Metering and sub-metering Class 0.5S IEC 62053-22 Class 1 IEC 62053-21 Class 2 IEC 62053-23	Power and energy meter ANSI C12.20 0.2% IEC 62053-22 Class 0.2S	Metering and sub-metering Class 0.5S IEC 62053-22 Class 1 IEC 62053-21 Class 2 IEC 62053-23	DIN rail power and energy meter ANSI 12.20 0.2% accuracy, IEC 62053-22 Class 0.2S for EM35xx models, ANSI C12.20 0.5% accuracy, IEC 62053-22 Class 0.2S for EM35xxA models
<b>Applications Panel instrumentation</b>						
Panel instrumentation	E (power demand)	I, V, F, kW, kVAR, kVA, PF, E (power demand and current demand)	I, V, F, kW, kVAR, kVA, PF, E (power demand and current demand)	I, V, F, kW, kVAR, kVA, PF, E (Power demand and current demand)	I, V, F, kW, kVAR, kVA, PF, E (power demand and current demand)	I, V, F, kW, kVAR, kVA, PF, E (power demand and current demand)
<b>Energy efficiency and cost</b>						
Sub-billing and cost allocation	■	■	■	■	■	■
Demand and load management		■	■	■	■	■
Billing analysis						
<b>Power availability and reliability</b>						
Compliance monitoring						
Sag and swell, transient						
Harmonics						
<b>Revenue metering</b>						
Revenue metering						
<b>Characteristics</b>						
Measurement accuracy	±1% of reading from 2% to 100% of the CT current rating	Class 0.5S/Class 1	Class 0.5	ANSI C12.20 Class 0.2S IEC 62053-22 Class 0.2S	Class 0.5S	Class 1 (mains active energy)
Installation	Surface mount, enclosure provided	DIN rail	DIN rail	DIN rail, screw, clip-on, or hook	Flush mount or DIN rail	DIN rail
Voltage measurement	Basic: 120/240V, 208Y/120V Extended: 120/240V, 480Y/277V	50–330 V (Ph-N) 80–570 V (Ph-Ph) up to 1MV AC (ext VT)	50–330 V AC (Ph-N) 80–570 V AC (Ph-Ph) up to 1M V AC (ext VT)	890–480 V AC L-L	60–400 V AC L-N 103.5–690 V AC L-L	90 V L-N–600 V L-L
Current measurement	100A to 1600A, CTs included with meter	Internal or External CT	External CT	External CT, 5–5000 A	External CT	External LVCT or Rogowski coil CTs (EM35xxA models)
Communication ports	1	1	1	1	1	1
Inputs/outputs	1 I/O	2 I/O	2 I/O		2 I/O	up to 2 I/O
Memory capacity						(see datasheet)

[Link to: \*\*page 18\*\* Datasheet](#)    
 [page 26](#) Datasheet    
 [page 40](#) Datasheet    
 [page 74](#) Datasheet    
 [page 60](#) Datasheet    
 [page 68](#) Datasheet

# Panorama of the PowerLogic range (cont.)

Basic multi-function metering cont	Intermediate metering	Advanced metering	
------------------------------------	-----------------------	-------------------	--



Name	PM5100/PM5300/PM5500	PM8000	ION7550/ION7650	CM4000T
Function	Metering and sub-metering Class 0.5S IEC 62053-22 Class 0.2S (PM55xx) IEC 62053-22 Class 1/2 IEC 62053-24 IEC 61557-12	Energy and basic power quality meter IEC 61557-12 IEC 62053-22 IEC 61000-4-30 Class S IEC 62586 ANSI C12.20 Class 0.2 PMD/Sx/K70/0.2	Energy and power quality meter IEC 62052-11 IEC 62053-22/23 Class 0.2S IEC 61000-4-30 Class A	Energy and power quality meter Class 0.5S IEC 62053-22 ANSI 12.20 Class 0.2S real energy impulsive transient detection
<b>Applications Panel instrumentation</b>				
Panel instrumentation	I, V, F, kW, kVAR, kVA, PF, E (power demand and current demand)	I, V, F, kW, kVAR, kVA, PF, E Min/Max, harm, alarm, I/O (I, U unbalance, demand, clock/cal	I, V, F, kW, kVAR, kVA, PF, E (Demand, minimum, and maximum values)	
<b>Energy efficiency and cost</b>				
Sub-billing and cost allocation	■	■	■	■
Demand and load management	■	■	■	■
Billing analysis		■	■	■
<b>Power availability and reliability</b>				
Harmonics	■	■	■	■
Sag/swell, transient		■	■	■
Compliance monitoring		■	■	■
<b>Revenue metering</b>				
Revenue metering				
<b>Characteristics</b>				
Measurement accuracy (active energy)	Class 0.2S (PM55xx) Class 0.5S	IEC 61053-22 Class 0.2S ANSI 12.20 Class 0.2S	Class 0.2S	Class 0.2S
Installation	Flush and DIN rail mount 3.77 in x 3.77 in (96mm x 96mm)	Flush and DIN rail mount 3.77 in x 3.77 in (96 mm x 96 mm)	DIN 192 Standard cutout 7.32 in x 7.32 in (186 mm x 186 mm)	Panel mounted
Voltage measurement	20–400 V L-N 20–690 V L-L (PM55xx)	57–400 V AC L-N 3P (100–690 V AC L-L)	57–347 V L-N AC or 100–600 V L-L AC	Mounting pan 0–600 V AC
Current measurement	External CT	External CT	External CT	External CT
Communication ports	up to 3	3	5	3
Inputs/outputs	1DO for PM51xx 4/6 I/O PM53xx based on model 6 I/O for PM55xx	Up to 27 DI, 9 DO Up to 16 AI, 8 AO	Up to 32 I/O	Up to 25 I/O
Memory capacity	256 kb 1.1 MB (PM55xx)	512 MB	Up to 10 MB	Up to 32 MB

Link to: [page 48 Datasheet](#)

[page 84 Datasheet](#)

[page 98 Datasheet](#)

[page 108 Datasheet](#)

# Panorama of the PowerLogic range (cont.)

**Advanced metering (cont.)** | **Advanced utility metering**



Name	ION9000	ION7400	ION8650		
			A	B	C
Function	Energy and advanced power quality meter IEC 62053-22 Class 0.1S ANSI C12.20 Class 0.1 IEC 61000-4-30 Class A IEC 62586 IEC 61557-12 PMD/SD/K70/0.2 IEC 61557-12 PMD/SS/K70/0.2 UL 61010-1	Energy and basic power quality meter IEC 61557-12 IEC 62053-22 IEC 61000-4-30 Class S IEC 62586 ANSI C12.20 Class 0.2 PMD/Sx/K70/0.2	Energy and power quality meter IEC 62052-11 IEC 62053-22/23 Class 0.2S IEC 61000-4-30 Class A		
<b>Applications Panel instrumentation</b>					
Panel instrumentation	I, U, F, P, Q, S, PF, E, THD, Min/Max, harm, alarm, I/O (I, U unbalance, demand, clock/cal, dip/swell, transients, flicker, RVC, mains signalling, 1/2 cycle RMS)	I, V, F, kW, kVAR, kVA, PF, E Min/Max, harm, alarm, I/O (I, U unbalance, demand, clock/cal)	I, V, F, kW, kVAR, kVA, PF, E (demand, minimum and maximum values)		
<b>Energy efficiency and cost</b>					
Sub-billing and cost allocation	■	■	■		
Demand and load management	■	■	■		
Billing analysis	■	■	■		
<b>Power availability and reliability</b>					
Harmonics	■	■	■		
Sag/swell, transient	■	■	■		
Compliance monitoring	■	■	■		
<b>Revenue metering</b>					
Revenue metering		■	■		
<b>Characteristics</b>					
Measurement accuracy (active energy)	IEC 62053-22 Class 0.1S ANSI C12.20 Class 0.1	IEC 61053-22 Class 0.2S ANSI 12.20 Class 0.2S	Class 0.2S		
Installation	Flush & DIN (160 mm x 160 mm) Display (96 mm or 197 mm x 175 mm)	Flush and DIN rail mount 3.77 in x 3.77 in (96 mm x 96 mm)	ANSI socket mount 9S, 35S, 36S, 39S and 76S; FT21 switchboard case		
Voltage measurement	57-400 V L-N AC or 100-690 V L-L AC	57-400 V AC L-N 3P (100-690 V AC L-L)	57-277 V L-N AC (9S, 36S); 120-480 V L-L AC (35S)		
Current measurement	External CT	External CT	External CT		
Communication ports	4	2	5		
Inputs/outputs	up to 32 DI, 4 DO, 10 RO (relay) up to 16 AI, 8 AO	Up to 27 DI, 9 DO Up to 16 AI, 8 AO	Up to 22 I/O		
Memory capacity	2 GB	512 MB	10 MB 4 MB 2 MB		

Link to: [page 116 Datasheet](#)

[page 132 Datasheet](#)

[page 142 Datasheet](#)

# Panorama of the PowerLogic range (cont.)

## Multi-circuit metering



Name	BCPM	EM4900	EM4000	EM4800
Function	Branch circuit monitor IEC 61036 Class 1	Multi-circuit energy and power meter	Multi-circuit energy meter Class 0.5 ANSI C12.1, C12.20 Class 0.5S IEC 62053-22	Multi-circuit energy meter Class 0.5 ANSI C12.1, C12.20 Class 0.5S IEC 62053-22
<b>Applications</b>				
<b>Panel Instrumentation</b>				
Panel instrumentation	I, V, F, kW, kVAR, kVA, PF, E (Power demand and current demand)	I, V, F, kW, kVAR, kVA, PF, E (Power demand and current demand)	I, V, F, kW, kVAR, kVA, PF, E (Power demand and current demand)	I, V, F, kW, kVAR, kVA, PF, E (Power demand and current demand)
<b>Energy efficiency and cost</b>				
Sub-billing and cost allocation	■	■	■	■
Demand and load management	■	■	■	■
Billing analysis				
<b>Power availability and reliability</b>				
Compliance monitoring				
Sag and swell, transient				
Harmonics	■	■		
<b>Revenue metering</b>				
Revenue metering				
<b>Characteristics</b>				
Measurement accuracy	Class 1 (mains active energy)	Class 0.5S	Class 0.5S	Class 0.5S
Installation	Panel or enclosure	Panel or enclosure	Panel or enclosure	Panel or enclosure
Voltage measurement	90–277 V line to neutral voltage inputs	150 – 480 V AC L-L 90 – 277 V AC L-N	80–480 V AC L-L without PTs, Up to 999 kV with external PTs	80–480 V AC L-L without PTs, Up to 999 kV with external PTs
Current measurement	CT strips for branch circuits and external CTs for mains	Split- or solid-core CTs	Split- or solid-core CTs	Split- or solid-core CTs
Communication ports	1	Up to 2	2	2
Inputs/outputs			2	2
Memory capacity				

Link to: [page 156 Datasheet](#)

[page 170 Datasheet](#)

[page 178 Datasheet](#)

[page 186 Datasheet](#)

# Panorama of the PowerLogic range (cont.)

**Communications and gateways**

**Monitoring software**



Name	Link150	Com'X 210 Com'X 510	ION7550 RTU	EcoStruxure™ power management software
Function	Modbus serial to Modbus TCP/IP protocol gateway	Modbus gateway plus energy server and Cloud connector	Ethernet gateway-server + onboard I/O	Power management, network protection, and control
<b>Features</b>				
RS-485/Ethernet gateway	Ethernet gateway	Ethernet gateway		
Devices supported	All Modbus devices	100+ known Schneider Electric devices and the ability to create custom Modbus models. EM3000 series, iEM3000 series, Acti 9 Smartlink masterpact, PM5000 series, compact NSX, iEM1, iEM2000 series, PM3000 series, PM5350, PM5000, PM8000, ION7550/7650, CM4000	ION7550/7650, Modbus devices PM5000 PM8000	100+ Schneider Electric devices EcoStruxure Power Monitoring Expert EcoStruxure Power SCADA Operation
Web server with standard HTML pages	Configuration only	Com'X 510 — full support Com'X 210 — configuration only		
Web server with custom HTML pages		Custom web page support		
Real-time data		Real-time data available on Com'X 510		
Historical data		Com'X 510 onboard storage Com'X 210 — publish to database server		
Automatic notification		Event notification to FI		
Alarm and event logs				
Waveform display			RTU includes alarm and event logs	
Custom animated graphics				
Manual/automatic reports				
<b>Characteristics</b>				
Ethernet ports Modbus TCP/IP protocol	2 (switch mode only)	2	10/100 Base TX port	EcoStruxure™ is a suite of interoperable, and scalable supervisory software dedicated to power monitoring that enables you to maximize operational efficiency, optimize power distribution systems, and improve bottom-line performance.
RS-485 (2-wire/4-wire) ports Modbus protocol	2w/4w – 1 (rj45)	1	3	
Number of devices connected directly	32	64 devices/32 max Modbus, 2 analogue sensors	64	
RS-232 configuration ports	1		1	
Miscellaneous	Serial line to Ethernet connectivity — serial or Ethernet master	Connectivity: WiFi, Ethernet, Zigbee, GPRS, + 3G	Modem port I/O (20 I/12 O)	
Installation	9 DIN rail	DIN rail	DIN 192 cutout 186 x 186 mm	

**Link to:** [page 196](#)  
**Datasheet**

[page 204](#)  
**Datasheet**

[page 210](#)  
**Datasheet**

[page 218](#)  
**Datasheet**

NOTES

---

# Basic energy metering



# Applications

Basic energy meters are designed for submetering/billing and cost allocation of energy consumed for each sector, unit, workshop, etc. in buildings, industry, data centers, and infrastructure.

# Product overview

## Basic energy metering

Our energy meters are designed to gather the data you need to clearly understand your energy costs. Whether you require a single-phase kWh meter or full-featured, dual tariff energy meter, Schneider Electric offers a meter that is the best fit for your application.

- PowerLogic energy meters
- Acti 9 iEM3000 series

BASIC ENERGY METERING



# PowerLogic energy meters

## Functions and characteristics

The PowerLogic energy meter combines highly accurate, industrial-grade split-core CTs and precision, microprocessor-based metering electronics to provide exceptional metering accuracy and greatly reduce the total metering system installed cost. The accuracy of the energy meter is plus or minus one percent of reading from two percent (2 A with a 100 A CT) to one hundred percent of the current rating of the CT. The meter display provides valuable installation diagnostics. If the meter is installed and the CTs and voltage leads are not properly matched, the display gives the installer feedback as to what is wrong. The PowerLogic energy meter comes in two different models: basic and extended range.

### Applications

- Tenant submetering
- Cost allocation
- Performance contracting
- Real-time power monitoring
- LEED certification
- EPACK 2005 compliance
- Demand response



Energy meter and CTs

## BASIC ENERGY METERING

### The solution for

Markets that can benefit from a solution that includes PowerLogic energy meters:

- Buildings
- Healthcare
- Data centers

---

### Benefits

- Improve energy efficiency and reduce energy-related costs
- Accurately allocate costs
- Access reliable and accurate submetering

### Competitive advantages

- Compact, scalable energy-management solution
- Exceptional metering accuracy
- True reading display, no multipliers required

---

### Conformity of standards

- ANSI C12.15 ± 1% accuracy

# PowerLogic energy meters

## Functions and characteristics

### Features

#### High-resolution, back-lit liquid crystal display

- Provides clear data readings from a distance under all lighting conditions.

#### True reading display

- No multipliers are required for data readings. The true reading is what you see in the display.

#### High accuracy

- $\pm 1\%$  systems accuracy from 2–100% of the CT rating meets ANSI C12.1 metering accuracy standards.

#### kW demand metering

- The optional EMCB also provides kW demand monitoring in the energy meter. The user can set the demand interval from five minutes to one hour to accurately measure kW demand.

#### Simple, fast installation

- Factory assembled split-core CTs greatly reduce installation time. The meter automatically corrects for phase reversal, eliminating concern with CT load orientation. To simplify installation further, CTs and voltage terminals are color coded, making it easy to determine the correct phase matching.

#### Easy integration to PowerLogic or control/data acquisition systems

- Extended models have pulse output contacts, selectable from 1/10 to 1 kWh per pulse, for easy integration to existing control systems.

#### Automatic meter reading

- The optional energy meter communications board (EMCB) provides serial Modbus® RS-485 RTU communications for connecting the energy meter to a remote monitoring system. With the addition of the EMCB, the energy meter can be used with PowerLogic software for electrical cost allocation and billing of sub-metered electrical systems.

Basic 120/240 Volt 208 Y/120 V	
Model	Description
EMB1010	Basic 100 A, .518" x 1.28" ID, 1 CT
EMB1021	Basic 200 A, .75" x 1.10" ID, 1 CT
EMB1032	Basic 300 A, 1.25" x 1.51" ID, 1 CT
EMB2010	Basic 100 A, .518" x 1.28" ID, 2 CTs
EMB2021	Basic 200 A, .75" x 1.10" ID, 2 CTs
EMB2032	Basic 300 A, 1.25" x 1.51" ID, 2 CTs
EMB2043	Basic 400 A, 2.45" x 2.89" ID, 2 CTs
EMB2083	Basic 800 A, 2.45" x 2.89" ID, 2 CTs
EMB3010	Basic 100 A, .518" x 1.28" ID, 3 CTs
EMB3021	Basic 200 A, .75" x 1.10" ID, 3 CTs
EMB3032	Basic 300 A, 1.25" x 1.51" ID, 3 CTs
EMB3043	Basic 400 A, 2.45" x 2.89" ID, 3 CTs
EMB3083	Basic 800 A, 2.45" x 2.89" ID, 3 CTs
EMB3084	Basic 800 A, 2.45" x 5.50" ID, 3 CTs
EMB3164	Basic 1600 A, 2.45" x 5.50" ID, 3 CTs

Extended Range 120/240 Volt to 480 Y/277 V (4 wire)	
Model	Description
EME1010	Extended Range 100 A, .518" x 1.28" ID, 1 CT
EME1021	Extended Range 200 A, .75" x 1.10" ID, 1 CT
EME1032	Extended Range 300 A, 1.25" x 1.51" ID, 1 CT
EME2010	Extended Range 100 A, .518" x 1.28" ID, 2 CTs
EME2021	Extended Range 200 A, .75" x 1.10" ID, 2 CTs
EME2032	Extended Range 300 A, 1.25" x 1.51" ID, 2 CTs
EME2043	Extended Range 400 A, 2.45" x 2.89" ID, 2 CTs
EME2083	Extended Range 800 A, 2.45" x 2.89" ID, 2 CTs
EME3010	Extended Range 100 A, .518" x 1.28" ID, 3 CTs
EME3021	Extended Range 200 A, .75" x 1.10" ID, 3 CTs
EME3032	Extended Range 300 A, 1.25" x 1.51" ID, 3 CTs
EME3043	Extended Range 400 A, 2.45" x 2.89" ID, 3 CTs
EME3083	Extended Range 800 A, 2.45" x 2.89" ID, 3 CTs
EME3084	Extended Range 800 A, 2.45" x 5.50" ID, 3 CTs
EME3164	Extended Range 1600 A, 2.45" x 5.50" ID, 3 CTs

# PowerLogic energy meters

## Dimensions

	Product type	EMB meter	EME meter
Form factor	Socket with integral display	-	-
	Panel mount with integral display	-	-
	DIN mount transducer with optional remote display	-	-
	DIN mount with integral display	-	-
	Retrofit inside equipment	-	-
	Self-enclosed	•	•
Accuracy	Current accuracy	-	-
	Voltage accuracy	-	-
	Power accuracy	1.0%	1.0%
	Samples per cycle or sample frequency	1280 Hz	1280 Hz
Control power	AC	•	•
	DC	-	-
	Low voltage DC	-	-
Current sensor type	CT	-	-
	80 mA CT	-	-
	LVCT	•	•
	Rope (Rogowski coil)	-	-
Input metering capability	Number of measurement channels	3	3
	Direct voltage connection (max)	240V	480V
	Wiring self-test	-	-
Instantaneous values	Current (I) total and per phase	•	•
	Voltage (V) total and per phase	•	•
	Frequency (F)	-	-
	Active power (kW) total and per phase	•	•
	Reactive power (kVAR) total and per phase	•	•
	Apparent power (kVA) total and per phase	-	-
	Power factor (PF) total and per phase	•	•
Energy values	Active energy (kWh) total and per phase	•	•
	Reactive energy (kVARh) total and per phase	-	-
	Apparent energy (kVAh) total and per phase	-	-
	Settable accumulation modes	-	-
Demand values	Current demand (Id) present and max values	-	-
	Active power demand (kWd) present and max values	Present only	Present only
	Reactive power demand (kVARd) present and max values	-	-
	Apparent power demand (kVAd) present and max values	-	-
	Predicted power demand, active (kWd), reactive (kVARd), and apparent (kVAd)	-	-
	Synchronization of the demand measurement window	-	-
	Demand modes: fixed block, sliding, rolling, etc.	-	-
	Demand modes: thermal	-	-

# PowerLogic energy meters

## Dimensions

	Product type	EMB meter	EME meter
Power quality measurements	Harmonic distortion — current and voltage	-	-
	Individual harmonics — via front panel	-	-
	Individual harmonics — via software	-	-
	Waveform capture	-	-
	Transient capture	-	-
	Detection of voltage sags and swells	-	-
	Disturbance direction detection	-	-
	IEC 61000-4-30 class A/S	-	-
	IEC 61000-4-15 (flicker)	-	-
	High-speed data recording	-	-
	EN50160 compliance reporting	-	-
	Programmable (logic and math functions)	-	-
Data recording	Onboard memory (in MB)	-	-
	Revenue logs	-	-
	Min/max of instantaneous values	-	-
	Data logs	-	-
	Event logs	-	-
	Trending/forecasting	-	-
	Alarms	-	-
	Alarm setpoint learning	-	-
	Alarm notification via email	-	-
	Sequence of events recording	-	-
	Historical logs	-	-
	Harmonics logs	-	-
	Sag and swell logs	-	-
	Data update rate	-	-
	Transient logs	-	-
Time stamping	Time stamp resolution	-	-
	Time synchronization — IRIG-B	-	-
	Time synchronization — DCF-77	-	-
Inputs/outputs (I/O)	Pulse output (front panel LED)	-	•
	Base digital inputs DI	-	-
	Base digital outputs DO solid state	-	2
	Base digital outputs DO relay	-	-
	Option digital inputs DI (max)	-	-
	Option digital outputs DO solid state (max)	-	-
	Option digital outputs DO relay (max)	-	-
	Option analog inputs AI (max)	-	-
Option analog outputs AO (max)	-	-	

# PowerLogic energy meters

## Dimensions

	Product type	EMB meter	EME meter
Communication ports	ANSI 12.18 Type II optical port	-	-
	USB	-	-
	RS 485/RS 232 port	-	-
	RS485 2 wire	-	-
	RS485 2/4 wire	-	EMCB
	RS232	-	-
	Ethernet 10/100BASE-TX	-	-
	Internal modem	-	-
	IRIG-B port	-	-
	100BASE-FX	-	-
	Zigbee Pro (wireless)	-	-
Serial protocols	Modbus RTU	-	EMCB
	Modbus ASCII	-	-
	ION	-	-
	DNP 3	-	-
	DLMS IEC 62056	-	-
	Jbus	-	-
	M-Bus	-	-
	LONworks	-	-
	BACnet MS/TP	-	-
	MV-90	-	-
Ethernet protocols	Modbus TCP/IP	-	-
	ION TCP	-	-
	DNP 3 TCP	-	-
	IEC61850	-	-
	COMTRADE IEC 60255-24	-	-
	BACnet IP	-	-
	HTTP web server	-	-
	SNMP	-	-
	SMTP email	-	-
	FTP file transfer	-	-
	XML	-	-
	NTP time synchronization	-	-
	SNTP time synchronization	-	-
Gateway function	Ethernet Modbus gateway	-	-
	Modem gateway	-	-

BASIC ENERGY METERING

# PowerLogic energy meters

## Dimensions

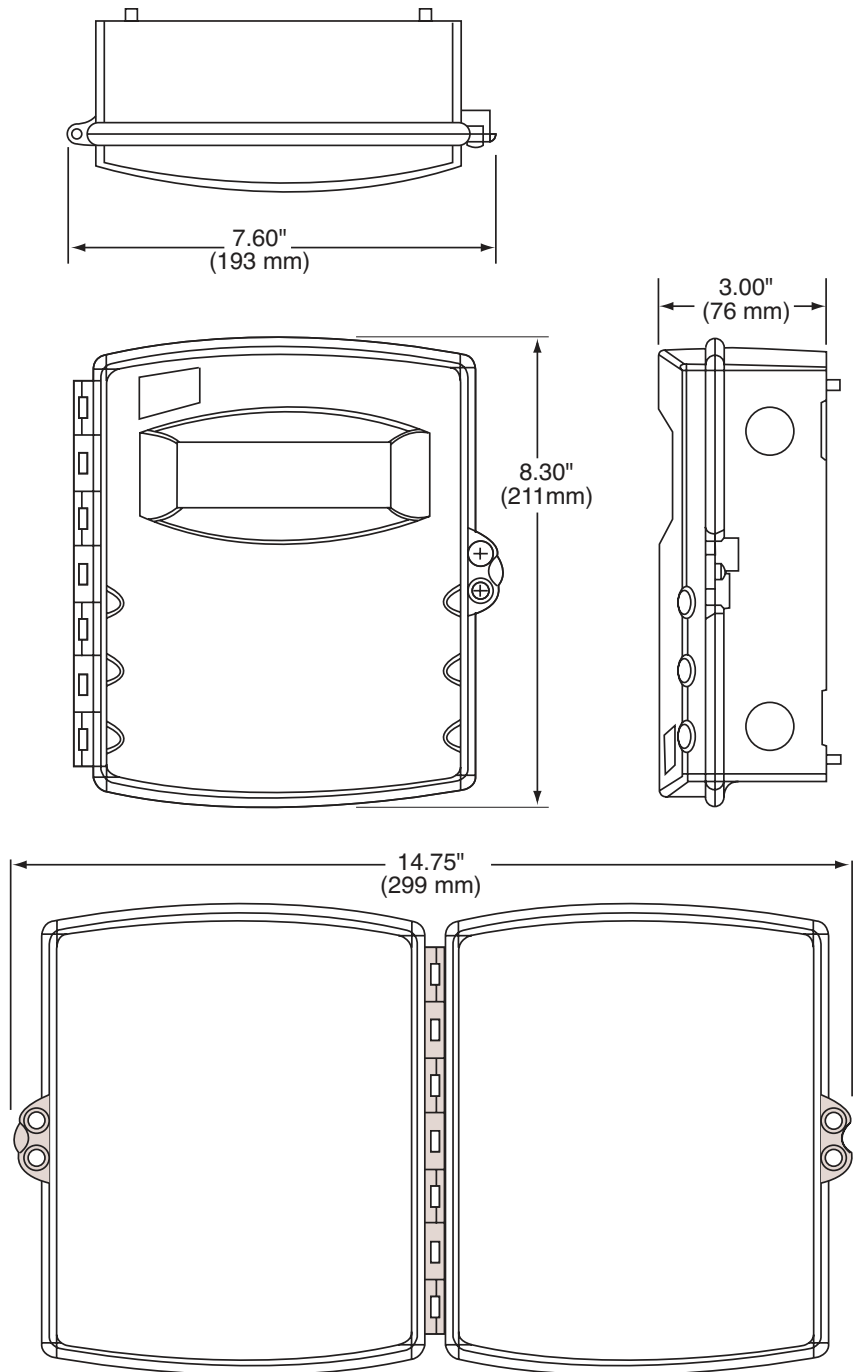

Energy meter dimensions

# PowerLogic energy meters

## Dimensions

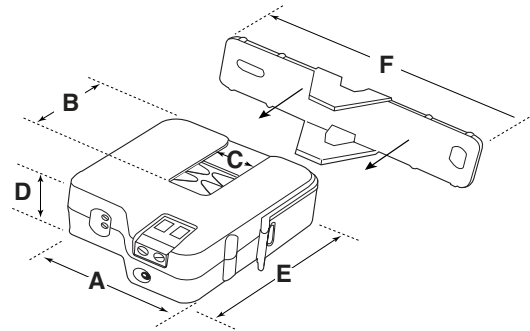

### Size 0

A =	2.0"	(55 mm)
B =	1.28"	(33 mm)
C =	.518"	(13 mm)
D =	.915"	(23 mm)
E =	2.34"	(60 mm)
F =	3.52"	(90 mm)

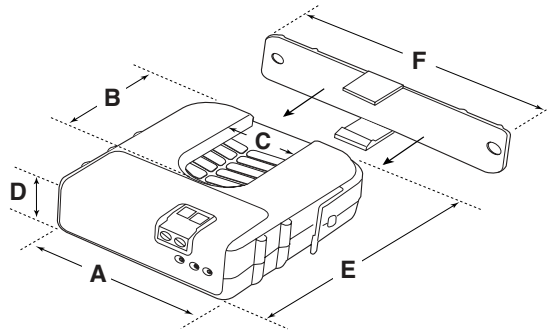

### Size 1

A =	2.58"	(81 mm)
B =	1.90"	(48 mm)
C =	.90"	(23 mm)
D =	1.04"	(26 mm)
E =	2.90"	(74 mm)
F =	3.52"	(90 mm)

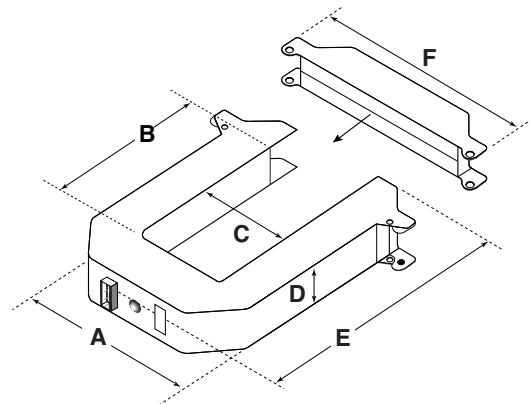

### Size 3

A =	4.90"	(124 mm)
B =	2.89"	(73 mm)
C =	2.45"	(62 mm)
D =	1.13"	(29 mm)
E =	5.57"	(141 mm)
F =	5.91"	(150 mm)

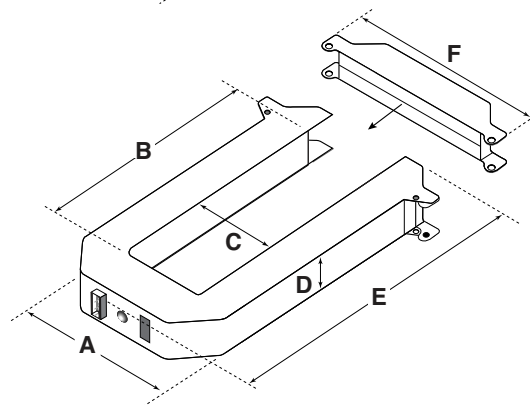

### Size 4

A =	4.90"	(124 mm)
B =	5.50"	(140 mm)
C =	2.45"	(62 mm)
D =	1.13"	(29 mm)
E =	8.13"	(207 mm)
F =	5.92"	(150 mm)

CT dimensions

## BASIC ENERGY METERING

# Acti 9 iEM3000 series

The Acti 9 iEM3000 series energy meters is a cost-attractive, feature-rich energy metering offer for DIN rail, modular enclosures. With Modbus, BACnet, M-Bus, and LON protocol support, you can easily integrate these meters into commercial and non-critical buildings to add simple energy management applications to any BMS, AMR, or EMS system.

## Applications

### Cost-management applications

- Bill checking to verify that you are only charged for the energy you use
- Sub-billing individual tenants for their energy consumption, including WAGES
- Aggregation of energy consumption, including WAGES, and allocating costs per area, per usage, per shift, or per time within the same facility

### Network-management applications

- Basic metering of electrical parameters to better understand the behavior of your electrical distribution system
- Onboard overload alarm to avoid circuit overload and trip
- Easy integration with PLC systems by input/output interface



## BASIC ENERGY METERING

More than just kWh meters, the Acti 9 iEM3000 series meters provide a full view of both energy consumption and on-site generation with full four-quadrant measurement of active and reactive energy delivered and received. Additionally, extensive real-time measurements (V, I, P, PF) give customers greater detail on their energy usage, and multiple tariffs give customers the flexibility to match the billing structure of their utility.

### The solution for

Markets that can benefit from a solution that includes PowerLogic iEM3000 series meters:

- Buildings and industry
- Data centers and networks
- Infrastructure (airports, road tunnels, telecom)

### Benefits

Optimize your energy consumption and enable energy-efficiency practices

- Collect and analyze energy consumption data from each area for each type of load or circuit
- Gain an accurate understanding of business expenses by allocating the energy-related costs
- Use information to implement actions designed to reduce energy consumption

Monitor the energy consumption of your tenants or customers and establish accurate invoices

- Drive energy-efficient behavior
- Allow building owners to bill tenants for individual measured utility usage
- Give accurate and achievable objectives for energy savings

### Competitive advantages

- Compact size
- Programmable digital inputs/outputs
- Multi-tariff capability
- Onboard Modbus, LON, M-Bus or BACnet communication
- A complete range of energy meters
- Compatible with Acti9 range

### Conformity of standards

- IEC 61557-12
- EN 50470-3
- IEC 62053-21/22
- IEC 61036
- IEC 62053-23
- IEC 61010

# Acti 9 iEM3000 series energy meters

## Functions and characteristics



Acti 9 iEM3100/3200 energy meter



Acti 9 iEM3300 energy meter

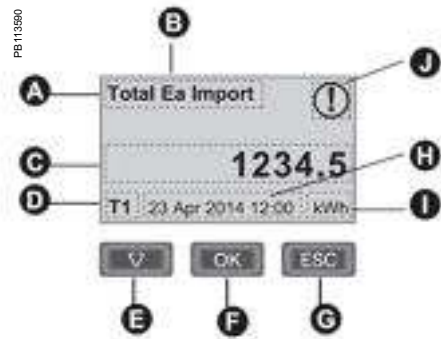

### Front panel display and buttons

- A** Measurement
- B** Ea/Er = active/reactive energy (if available)
- C** Value
- D** Active tariff (if applicable)
- E** Scroll through the available screens
- F** View more screens related to the measurement category (if available)
- G** Go back to previous screen
- H** Date and time (if applicable)
- I** Unit
- J** Icon indicating date/time not set

The Acti 9 iEM3000 energy meter series offers a cost-attractive, competitive range of DIN rail-mounted energy meters ideal for sub-billing and cost allocation applications. Combined with communication systems, like Smart Link, the Acti 9 iEM3000 series makes it easy to integrate electrical distribution measurements into customers' facility management systems. It's the right energy meter at the right price for the right job.

Several versions are available: 63 A direct measure (iEM3100 models), current transformers associated meter (iEM3200 models), and 125 A direct measure (iEM3300 models), low-voltage current transformers (iEM3400 models), and Rogowski coils (iEM3500 models). For each range, eight versions are available (seven for the iEM3300) to satisfy basic to advanced applications:

- iEM3100/iEM3200/iEM3300: kWh meter with partial counter
- iEM3110/iEM3210/iEM3310: kWh meter with partial counter and pulse output; MID certified
- iEM3115/iEM3215: multi-tariff meter controlled by digital input or internal clock, MID certified
- iEM3135/iEM3235/iEM3335: energy meter, four quadrant, multi-tariffs with partial digital I/O and MID certified
- iEM3150/iEM3250/iEM3350: kWh meter with partial counter and current, voltage, power measurement; Modbus communication
- iEM3155/iEM3255/iEM3355/iEM3455/iEM3555: energy meter, four quadrant, multi-tariffs with partial counter and current, voltage, power measurement; Modbus communication, digital I/O, MID certified (iEM3155, iEM3255, iEM3355 only)
- iEM3165/iEM3265/iEM3365/iEM3465/iEM3565: energy meter, four quadrant, multi-tariffs with partial counter and current, voltage, power measurement; BACnet communication, digital I/O and MID certified (iEM3165, iEM3265, iEM3365 only)
- iEM3175/iEM3275/iEM3375: energy meter, four quadrant, multi-tariffs with partial counter and current, voltage, power measurement; LON communication, digital input, and MID certified

### Innovative design makes the meters smart and simple

- Easy to install for panel builders (LVCT safer to install)
- Easy to commission for contractors and installers
- Easy to operate for end-users

### Characteristics

- Self-powered meters
- Chain measurement (meters + CTs) Accuracy Class 1 (selected models)
- Compliant with IEC 61557-12, IEC 62053-21/22, IEC 62053-23, EN50470-3
- Compact, 5-module width
- Graphical display for easy viewing
- Onboard Modbus, LON, M-Bus or BACnet communication
- Easy wiring (without CTs) Acti 9 iEM3100 and iEM3300 models
- Double fixation on DIN rail (horizontal or vertical)
- Anti-tamper security features ensure the integrity of your data
- MID-compliant (selected models, not iEM3455, iEM3465, iEM3555, iEM3565) providing certified accuracy and data security
- LVCT support (iEM3455 and iEM3465)
- Rogowski support (iEM3555 and iEM3565)

# Acti 9 iEM3000 series energy meters

## Functions and characteristics

Feature selection	iEM3100	iEM3110	iEM3135	iEM3150	iEM3155	iEM3165	iEM3175
	iEM3200	iEM3210	iEM3235	iEM3250	iEM3255	iEM3265	iEM3275
	iEM3300	iEM3310	iEM3335	iEM3350	iEM3355	iEM3455	iEM3555
Width (0.71 in, 18 mm module, DIN rail mounting)	5/5/7	5/5/7	5/5/7	5/5/7	5/5/7/5/5	5/5/7/5/5	5/5/7
Direct measurement (up to 63 A or 125 A)	63 A/-/125 A	63 A/-/125 A	63 A/-/125 A	63 A/-/125 A	63 A/-/125 A/ LVCT/Rog.	63 A/-/125 A/ LVCT/Rog.	63 A/-/125 A
Measurement inputs through CTs (1 A, 5 A)	-/■/-	-/■/-	-/■/-	-/■/-	-/■/-/ LVCT/Rog.	-/■/-/ LVCT/Rog.	-/■/-
Measurement inputs through VTs			-/■/-	-/■/-	-/■/-/■/■	-/■/-/■/■	-/■/-
Active energy measurements class (total and partial kWh)	1/0.5S/1	1/0.5S/1	1/0.5S/1	1/0.5S/1	1/0.5S/1/ 0.5S/0.5S	1/0.5S/1/ 0.5S/0.5S	1/0.5S/1
Four Quadrant Energy measurements			■		■	■	■
Electrical measurements (I, V, P, ...)			■	■	■	■	■
Multi-tariff (internal clock)			4		4	4	4
Multi-tariff (external control)			2		2	2	2
Measurement display (number of lines)	3	3	3	3	3	3	3
Digital inputs	Programmable (tariff control or wages input)		1		1	1	1
	Tariff control only						
Digital outputs	Programmable (kWh pulse or kW alarm)		1		1	1	
	kWh pulse only		1				
kW overload alarm			1		1	1	
M-Bus protocol			■				
Modbus protocol				■	■		
BACnet protocol						■	
LON							■
MID (legal metrology certification)		■	■		3155/3255/ 3355	3165/3265/ 3365	■



Acti 9 iEM3100 models direct connected (63 A)



Acti 9 iEM3200 models (1 A/5 A CT connected)

### Connectivity advantages

Programmable digital input	External tariff control signal (4 tariffs) Remote Reset partial counter External status, e.g., breaker status Collect WAGES pulses
Programmable digital output	kWh overload alarm (iEM3135, iEM3155, iEM3165, iEM3235, iEM3255, iEM3265, iEM3335, iEM3355, iEM3365, iEM3455, iEM3465, iEM3555, iEM3565) kWh pulses
Graphic LCD display	Scroll energies Current, voltage, power, frequency, power factor
Communication	Serial communication options are available with M-Bus, Modbus, BACnet, or LON protocols

### Standards

Industry standards	IEC 61557-12, IEC 61036, IEC 61010, UL61010-1, IEC 62053-21/22 Class 1 and Class 0.5S, IEC 62053-23 ANSI C12.20 0.5%
--------------------	--

### Multi-tariff capability

The Acti 9 iEM3000 series allows arrangement of kWh consumption in four different registers. This can be controlled by:

- Digital inputs; signal can be provided by PLC or utilities
- Internal clock programmable by HMI
- Through communication

### This function allows users to:

- Make tenant metering for dual-source applications to differentiate backup source or utility source
- Understand well the consumption during working time and non-working time, and between working days and weekends
- Follow-up feeders consumption in line with utility tariff rates

# Acti 9 iEM3000 series energy meters

## Functions and characteristics

### Technical specifications iEM3100/iEM3300 models

	iEM3100 iEM3300	iEM3110 iEM3310	iEM3135 iEM3335	iEM3150 iEM3350	iEM3155 iEM3355	iEM3165 iEM3365	iEM3175 iEM3375
Max current (direct connection)	63A for iEM3100 models, 125A for iEM3300 models						
Meter constant LED	500/kWh						
Pulse output		Up to 1000p/kWh	Up to 1000p/kWh			Up to 1000p/kWh	
Multi-tariff			4 tariffs			4 tariffs	
Communication			M-Bus	Modbus	Modbus	BACnet	LON
DI/DO		0/1	1/1		1/1	1/1	1/0
Network	1P+N, 3P, 3P+N						
Accuracy class	Class 1 (IEC 62053-21 and IEC61557-12) class B (EN50470-3)						
Wiring capacity	16 mm <sup>2</sup> , #6AWG for iEM3100 models, 50 mm <sup>2</sup> , #1AWG for iEM3300 models						
Display max	LCD 99999999.9kWh						
Voltage (L-L)	3 x 100/173 V AC to 3 x 277/480 V AC (50/60 Hz)						
IP protection	IP40 front panel and IP20 casing						
Temperature	-25°C to 55°C (K55)						
Product size	0.20 in x 0.71 in (7 x 18 mm) for iEM3100 models, 0.20 in x 0.71 in (7 x 18 mm) for iEM3300 models						
Overvoltage and measurement	Category III, degree of pollution 2						
kWh	■	■	■	■	■	■	■
kVARh			■		■	■	■
Active power			■	■	■	■	■
Reactive power			■		■	■	■
Currents and voltages			■	■	■	■	■
Overload alarm			■		■	■	■
Hour counter			■		■	■	■

BASIC ENERGY METERING

# Acti 9 iEM3000 series energy meters

## Functions and characteristics

### Technical specifications iEM3200 models

	iEM3200	iEM3210	iEM3235	iEM3250	iEM3255	iEM3265	iEM3275
Max current (1A/5A CT connected)	6 A						
Meter constant LED	5000/kWh						
Pulse output frequency		Up to 500p/kWh	Up to 500p/kWh		Up to 500p/kWh		
Multi-tariff			4 tariffs		4 tariffs		
Communication			M-Bus	Modbus	Modbus	BACnet	LON
DI/DO		0/1	1/1		1/1	1/1	1/0
Network	1P+N, 3P, 3P+N support CTs		1P+N, 3P, 3P+N support CTs & VTs				
Accuracy class	Class 0.5S (IEC 62053-22 and IEC61557-12) Class C (EN50470-3)(1)						
Wiring capacity	6 mm <sup>2</sup> , #10AWG for currents and 4 mm <sup>2</sup> , #12AWG for voltages						
Display max	LCD 99999999.9kWh or 99999999.9MWh						
Voltage (L-L)	3 x 100/173 V AC to 3 x 277/480 V AC (50/60 Hz)						
IP protection	IP40 front panel and IP20 casing						
Temperature	-25°C to 55°C (K55)						
Product size	5 steps of 0.71 in (18 mm)						
Overvoltage and measurement	Category III, degree of pollution 2						
kWh	■	■	■	■	■	■	■
kVARh			■		■	■	■
Active power			■	■	■	■	■
Reactive power			■		■	■	■
Currents and voltages			■	■	■	■	■
Overload alarm			■		■	■	■
Hour counter			■		■	■	■

(1) For 1 A CTs Class 1 (IEC 6253-21 and IEC 61557-12 Class B (EN 50470-3))

BASIC ENERGY METERING

# Acti 9 iEM3000 series energy meters

## Functions and characteristics

PB115417



Split-core LVCT00101S 100 A

PB115418



Split-core LVCT00102S 100 A

PB115419



Split-core LVCT00201S 200 A

PB115421



Split-core LVCT01004S 400 A

PB115422



Rope-style

Technical specifications	iEM3400/iEM3500 models			
	iEM3455	iEM3465	iEM3555	iEM3565
Max current	0.333V-1.0V LVCTs	0.333V-1.0V LVCTs	Rogowski coils	Rogowski coils
Meter constant LED	5000/kWh			
Pulse output frequency	Up to 500p/kWh			
Multi-tariff	4 tariffs			
Communication	Modbus	BACnet	Modbus	BACnet
DI/DO	1/1			
Network	1P+N, 3P, 3P+N support LVCTs, Rogowski coils, and VTs			
Wiring capacity	6 mm <sup>2</sup> , #10AWG for currents and 4 mm <sup>2</sup> , #12AWG for voltages			
Display max	LCD 99999999.9kWh or 99999999.9MWh			
Voltage (L-L)	3 x 100/173 V AC to 3 x 277/480 V AC (50/60 Hz)			
IP protection	IP40 front panel and IP20 casing			
Temperature	-25°C to 70°C (K55)			
Product size	5 steps of 0.71 in (18 mm)			
Overvoltage and measurement	Category III, degree of pollution 2			
kWh		■		
kVARh		■		
Active power		■		
Reactive power		■		
Currents and voltages		■		
Overload alarm		■		
Hour counter		■		

PB115488



iEM3455

PB115487



iEM3455 with sealing covers open LVCT00201S 200 A

# Acti 9 iEM3000 series energy meters

## Functions and characteristics

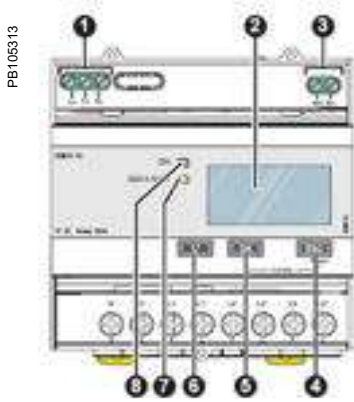

### Acti 9 iEM3000 series parts

- 1 Digital inputs for tariff control (iEM3115/iEM3215)
- 2 Display for measurement and configuration
- 3 Pulse out for remote transfer (iEM3110/iEM3210)
- 4 Cancellation
- 5 Confirmation
- 6 Selection
- 7 Flashing yellow meter indicator to check accuracy
- 8 Green indicator: on/off, error

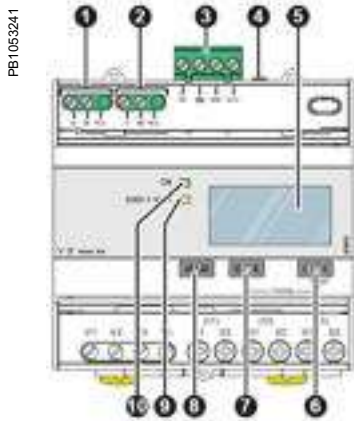

### Acti 9 iEM3000 series parts

- 1 Digital inputs for tariff control (iEM3155/iEM3255)
- 2 Digital output (iEM3155/iEM3255)
- 3 Communication port
- 4 Yellow indicator for communication diagnosis
- 5 Display for measurement and configuration
- 6 Cancellation
- 7 Confirmation
- 8 Selection
- 9 Flashing yellow meter indicator to check accuracy
- 10 Green indicator: on/off, error

### iEM3200/iEM3400/iEM3500 series dimensions

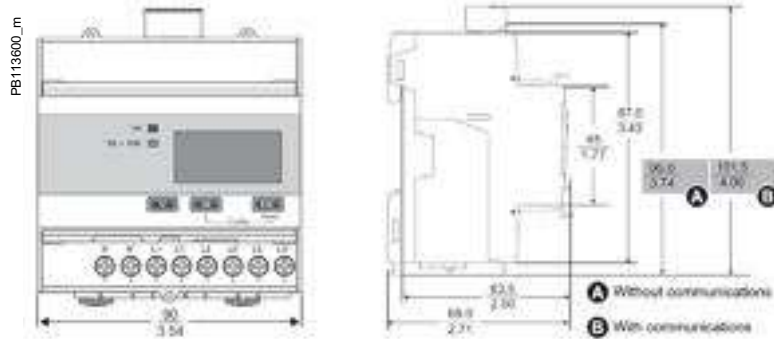

### iEM3100/iEM3200/iEM3400/iEM3500 series front sealing covers open and closed

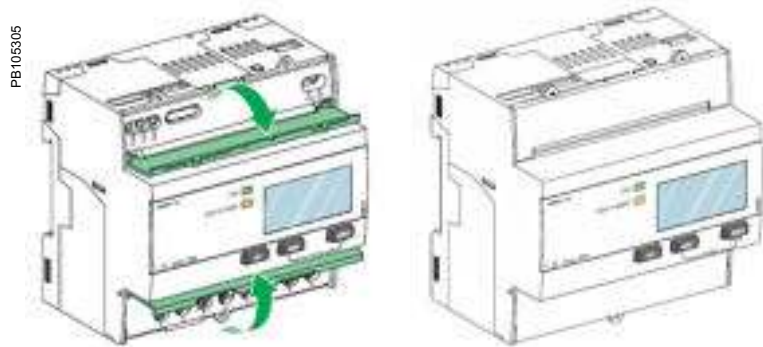

### iEM3300 series dimensions

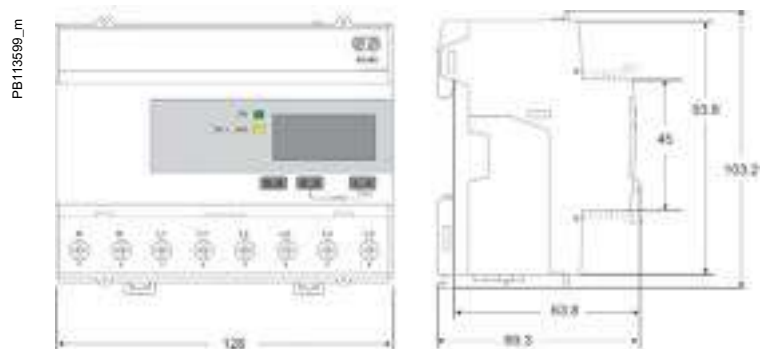

See appropriate product Installation Guide for further details.

# Acti 9 iEM3000 series energy meters

## Functions and characteristics

<b>iEM31xx/iEM32xx/iEM33xx Meter model and description</b>	<b>Current measurement</b>	<b>Commercial ref. no.</b>
iEM3100 basic energy meter	Direct connected 63 A	A9MEM3100
iEM3110 energy meter with pulse output	Direct connected 63 A	A9MEM3110
iEM3135 advanced multi-tariff energy meter and electrical parameter plus M-Bus comm port	Direct connected 63 A	A9MEM3135
iEM3150 energy meter and electrical parameter plus Modbus RS485 comm port	Direct connected 63 A	A9MEM3150
iEM3155 advanced multi-tariff energy meter and electrical parameter plus Modbus RS485 comm port	Direct connected 63 A	A9MEM3155
iEM3165 advanced multi-tariff energy meter and electrical parameter plus BACnet MS/TP comm port	Direct connected 63 A	A9MEM3165
iEM3175 advanced multi-tariff energy meter and electrical parameter plus LON TP/FT-10 comm port	Direct connected 63 A	A9MEM3175
iEM3200 basic energy meter	Transformer connected 5 A	A9MEM3200
iEM3210 energy meter with pulse output	Transformer connected 5 A	A9MEM3210
iEM3235 advanced multi-tariff energy meter and electrical parameter plus M-Bus comm port	Transformer connected 5 A	A9MEM3235
iEM3250 energy meter and electrical parameter plus Modbus RS485 comm port	Transformer connected 5 A	A9MEM3250
iEM3255 advanced multi-tariff energy meter and electrical parameter plus Modbus RS485 comm port	Transformer connected 5 A	A9MEM3255
iEM3265 advanced multi-tariff energy meter and electrical parameter plus BACnet MS/TP comm port	Transformer connected 5 A	A9MEM3265
iEM3275 advanced multi-tariff energy meter and electrical parameter plus LON TP/FT-10 comm port	Transformer connected 5 A	A9MEM3275
iEM3300 basic energy meter	Direct connected 125 A	A9MEM3300
iEM3310 energy meter with pulse output	Direct connected 125 A	A9MEM3310
iEM3335 advanced multi-tariff energy meter and electrical parameter plus M-Bus comm port	Direct connected 125 A	A9MEM3335
iEM3350 energy meter and electrical parameter plus Modbus RS485 comm port	Direct connected 125 A	A9MEM3350
iEM3355 advanced multi-tariff energy meter and electrical parameter plus Modbus RS485 comm port	Direct connected 125 A	A9MEM3355
iEM3365 advanced multi-tariff energy meter and electrical parameter plus BACnet MS/TP comm port	Direct connected 125 A	A9MEM3365
iEM3375 advanced multi-tariff energy meter and electrical parameter plus LON TP/FT-10 comm port	Direct connected 125 A	A9MEM3375
<b>iEM34xx/iEM35xx</b>	<b>Current measurement</b>	<b>Commercial ref. no.</b>
iEM3455 advanced multi-tariff energy meter and electrical parameter plus Modbus MS/TP comm port	LVCT	A9MEM3455
iEM3465 advanced multi-tariff energy meter and electrical parameter plus BACnet MS/TP comm port	LVCT	A9MEM3465
iEM3555 advanced multi-tariff energy meter and electrical parameter plus Modbus MS/TP comm port	Rogowski coil	A9MEM3555
iEM3565 advanced multi-tariff energy meter and electrical parameter plus BACnet MS/TP comm port	Rogowski coil	A9MEM3565
<b>LVCTs*</b>		<b>Commercial ref. no.</b>
CT, split-core, size 0, 50 A to 0.333 V		LVCT00050S
CT, split-core, size 1, 100 A to 0.333 V		LVCT00101S
CT, split-core, size 1, 200 A to 0.333 V		LVCT00201S
CT, split-core, size 2, 100 A to 0.333 V		LVCT00102S
CT, split-core, size 2, 200 A to 0.333 V		LVCT00202S
CT, split-core, size 2, 300 A to 0.333 V		LVCT00302S
CT, split-core, size 3, 400 A to 0.333 V		LVCT00403S
CT, split-core, size 3, 600 A to 0.333 V		LVCT00603S
CT, split-core, size 3, 800 A to 0.333 V		LVCT00803S
CT, split-core, size 4, 800 A to 0.333 V		LVCT00804S
CT, split-core, size 4, 1000 A to 0.333 V		LVCT01004S
CT, split-core, size 4, 1200 A to 0.333 V		LVCT01204S
CT, split-core, size 4, 1600 A to 0.333 V		LVCT01604S
CT, split-core, size 4, 2000 A to 0.333 V		LVCT02004S
CT, split-core, size 4, 2400 A to 0.333 V		LVCT02404S

See your Schneider Electric representative for complete ordering information.

BASIC ENERGY METERING

# Acti 9 iEM3000 series energy meters

## Functions and characteristics

Rogowski coils for iEM3555 and iEM3565 meters	Commercial ref. no.
ROGCOIL 12 in (0.30 m) 8 ft (2.40 m) 5000 A	METSECTR30500
ROGCOIL 18 in (0.45 m) 8 ft (2.40 m) 5000 A	METSECTR46500
ROGCOIL 24 in (0.60 m) 8 ft (2.40 m) 5000 A	METSECTR60500
ROGCOIL 36 in (0.90 m) 8 ft (2.40 m) 5000 A	METSECTR90500

\* Available in select countries (as used for BCPM accessories).  
 See your Schneider Electric representative for complete ordering information.

### LVCT split-core dimensions

These dimensions apply to both BCPMSCCTxx (branch CTs) and LVCT0xxx0S/1S (for Mains) 50 A-200 A CT families. Please note, the BCPMSCCTxx (branch CTs) will not work with the iEM3500 model.

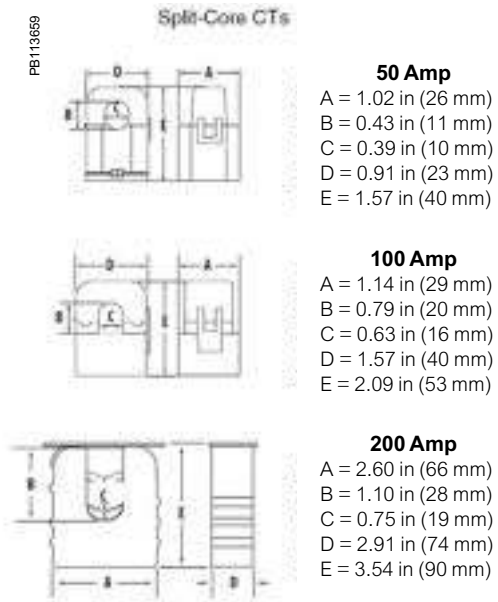

See appropriate product Installation Guide for further information.

# Basic multi-function metering

# Applications

Basic multi-function meters are designed for optimizing energy use and costs across your entire organization. They provide the measurement capabilities needed to allocate energy usage, perform tenant metering, and sub-billing.

As well as pin-point energy savings, you can optimize equipment efficiency and utilization. Basic multi-function meters perform a high-level assessment of the power quality in an electrical network.

# Product overview

## Basic multi-function metering

A range of meters designed for cost management and simple network management. Affordable to buy and easy to choose, these highly capable meters are designed to provide the best combination of features to match all your energy cost-management needs.

- PowerLogic PM3000
- PowerLogic PM5000
- PowerLogic ION6200
- PowerLogic EM3500
- PowerLogic EM4200

BASIC MULTI-FUNCTION METERING



## BASIC MULTI-FUNCTION METERING

# PM3000 series

The PowerLogic PM3000 series power meters are a cost-attractive, feature-rich range of DIN rail-mounted power meters that offer all the measurement capabilities required to monitor an electrical installation.

Ideal for power metering and network monitoring applications that seek to improve the availability and reliability of your electrical distribution system, the meters are also fully capable of supporting submetering and cost-allocation applications.

## Applications

### Cost-management applications

- Bill checking to verify that you are only charged for the energy you use
- Aggregation of energy consumption, including WAGES, and cost allocation per area, per usage, per shift or per time within the same facility
- Energy cost and usage analysis per zone, per usage, or per time period to optimize energy usage

### Network-management applications

- Metering of electrical parameters to better understand the behavior of your electrical distribution system



### The solution for

Markets that can benefit from a solution that includes PowerLogic PM3000 series meters:

- Buildings
- Industry
- Data centers and networks
- Infrastructure (e.g., airports, road tunnels, telecom)

---

### Benefits

Optimize your energy consumption and enable energy efficiency practices

- Collect and analyze energy consumption data from each area for each type of load or circuit
- Gain an accurate understanding of business expenses by allocating the energy-related costs
- Identify savings opportunities
- Use information to implement actions designed to reduce energy consumption

### Competitive advantages

#### Connectivity advantages

- Programmable digital input
  - External tariff control signal (4-tariff)
  - Remote reset partial counter
  - External status like breaker status
  - Collect WAGES pulses
- Programmable digital output
  - Alarm (PM3255)
  - kWh pulses
- Graphic LCD display
- Modbus RS485 with screw terminals

### Conformity of standards

- IEC 61557-12
- IEC 61000-4-2
- IEC 62052-11
- IEC 61000-4-3
- IEC 62053-21
- IEC 61000-4-4
- IEC 62053-22
- IEC 61000-4-5
- IEC 62053-23
- IEC 61000-4-6
- EN 50470-1
- IEC 61000-4-8
- EN 50470-3
- EN55022
- IEC 61010-1

### Multi-tariff capability

The PM3000 series allow arrangement of kWh consumption in four different registers. This can be controlled by:

- Digital inputs; signal can be provided by PLC or utilities
- Internal clock programmable by HMI
- Through communication

This function allows users to:

- Make tenant metering for dual-source applications to differentiate backup source or utility source
- Understand consumption during peak time and off-peak time, weekdays and weekends holidays, and working days, etc.
- Follow-up feeders consumption in line with utility tariff rates

# Power meter series PM3200

## Functions and characteristics



Power meter series PM3200

This PowerLogic power meter offers basic to advanced measurement capabilities. With compact size and DIN rail mounting, the PM3200 allows mains and feeders monitoring in small electrical cabinets. Combined with current transformers and voltage transformers, these meters can monitor 2-, 3-, and 4-wire systems. The graphic display has intuitive navigation to easily access important parameters.

Four versions are available offering basic to advanced applications

### PM3200 Range

- Electrical parameters I, In, U, V, PQS, E, PF, Hz
- Power/current demand
- Min/max

### PM3210

- Electrical parameters I, In, U, V, PQS, E, PF, Hz, TH
- Power/current demand, peak demand
- Min/max
- 5 timestamped alarms
- kWh pulse output

### PM3250

- Electrical parameters I, In, U, V, PQS, E, PF, Hz, TH
- Power/current demand, peak demand
- Min/max
- 5 timestamped alarms
- LED to indicate communications
- RS-485 port for Modbus communications

### PM3255

- Electrical parameters I, In, U, V, PQS, E, PF, Hz, TH
- Power/current demand and peak demand
- Flexible power and energy data logging
- Min/max and 15 timestamped alarm
- LED to indicate communication
- Up to 4-tariffs management
- 2 digital inputs, 2 digital output
- Memory for load profile (demand 10mn to 60mn)
- Memory for energy (kWh, kVARh, kVAh) logging at 10, 15, 20, 30, or 60 minutes
- RS-485 port for Modbus communications
- Innovative design makes the meters smart and simple
- Easy to install for panel builder
- Easy to commission for contractors and installer
- Easy to operate for end-user



Power meter series PM3255

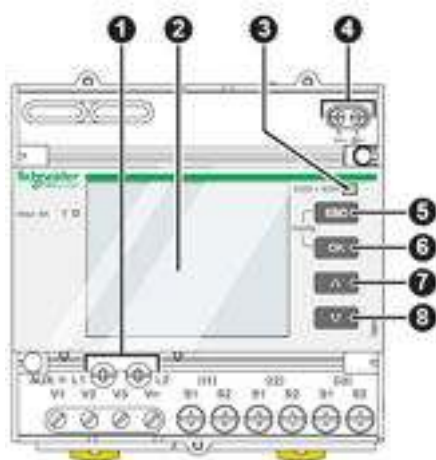

### Front of meter parts

- 1 Control power
- 2 Display with white backlit
- 3 Flashing yellow meter indicator (to check accuracy)
- 4 Pulse output for remote transfer (PM3210)
- 5 Cancellation
- 6 Confirmation
- 7 Up
- 8 Down

# Power meter series PM3200

## Functions and characteristics (cont.)

### Network-management application

- Panel instrumentation
- Up to 15 <sup>n</sup> board timestamped alarms to monitor event
- Easy integration with PLC system by input/output interface

### Commercial reference numbers

Meter model and description	Performance	Comm. ref. no.
PM3200 basic power meter	Basic power meter	METSEPM3200
PM3210 power meter with pulse output	Power, current, THD, peak demand	METSEPM3210
PM3250 power meter with RS-485 port	Power, current, THD, peak demand	METSEPM3250
PM3255 power meter plus 2 digital inputs, 2 digital outputs with RS485 port	Power, current, THD, peak demand, memory for load profile	METSEPM3255

# Power meter series PM3200

## Functions and characteristics (cont.)

### Feature selection PM3200 range

	PM3200	PM3210	PM3250	PM3255
<b>Performance standard</b>				
IEC61557-12 PMD/Sx/K55/0.5	■	■	■	■
<b>General</b>				
Use on LV and HV systems	■	■	■	■
Number of samples per cycle	32	32	32	32
CT input 1A/5A	■	■	■	■
VT input	■	■	■	■
Multi-tariff	4	4	4	4
Multi-lingual backlit display	■	■	■	■
<b>Instantaneous RMS values</b>				
Current, voltage	Per phase and average	■	■	■
Active, reactive, apparent power	Total and per phase	■	■	■
Power factor	Total and per phase	■	■	■
Energy values				
Active, reactive, and apparent energy; import and export	■	■	■	■
<b>Demand value</b>				
Current, power (active, reactive, apparent) demand; present	■	■	■	■
Current, power (active, reactive, apparent) demand; peak		■	■	■
<b>Power quality measurements</b>				
THD current and voltage		■	■	■
<b>Data recording</b>				
Min/Max of the instantaneous values	■	■	■	■
Power demand logs				■
Energy consumption log (day, week, month)				■
Alarms with timestamping		5	5	15
Digital inputs/digital outputs		0/1		2/2
<b>Communication</b>				
RS-485 port			■	■
Modbus protocol			■	■
Ordering reference	METSEPM3200	METSEPM3210	METSEPM3250	METSEPM3255



Power meter series PM3210

### Connectivity advantages

Programmable digital input	External tariff control signal (4-tariffs) Remote Reset partial counter External status like breaker status Collect WAGES pulses
Programmable digital output	Alarm (PM3255) kWh pulses
Graphic LCD display	Backlit graphic display allows smart navigation in relevant information and in multi-languages
Communication	Modbus RS-485 with screw terminals allows connection to a daisy chain

# Power meter series PM3200

## Functions and characteristics

Technical specifications	PM3200 range
Type of measurement	True RMS up to the 15th harmonic on three-phase (3P, 3P+N) and single-phase AC systems 32 samples per cycle
<b>Measurement accuracy</b>	
Current with x/5 A CTs	0.3 % from 0.5 A to 6 A
Current with x/1 A CTs	0.5 % from 0.1 A to 1.2 A
Voltage	0.3 % from 50 V to 330 V (Ph-N), from 80 V to 570 V (Ph-Ph)
Power factor	±0.005 from 0.5 A to 6 A with x/5 A CTs; from 0.1 A to 1.2 A with x/1 A CTs and from 0.5 L to 0.8 C
Active/apparent power with x/5 A CTs	Class 0.5
Active/apparent power with x/1 A CTs	Class 1
Reactive power	Class 2
Frequency	0.05 % from 45 to 65 Hz
Active energy with x/5 A CTs	IEC 62053-22 Class 0.5S
Active energy with x/1 A CTs	IEC 62053-21 Class 1
Reactive energy	IEC 62053-23 Class 2
<b>Data update rate</b>	
Update rate	1s
<b>Input-voltage characteristics</b>	
Measured voltage	50 V to 330 V AC (direct/VT secondary Ph-N) 80 V to 570 V AC (direct/VT secondary Ph-Ph) up to 1 M V AC (with external VT)
Frequency range	45 Hz to 65 Hz
<b>Input-current characteristics</b>	
CT primary	Adjustable from 1 A to 32767 A
CT secondary	1 A or 5 A
Measurement input range with x/5A CTs	0.05 A to 6 A
Measurement input range with x/1A CTs	0.02 A to 1.2 A
Permissible overload	10 A continuous, 20 A for 10s/hour
<b>Control Power</b>	
AC	100/173 to 277/480 V AC (+/-20 %), 3W/5 VA; 45 Hz to 65 Hz
DC	100 to 300 V DC, 3 W
<b>Input</b>	
Digital inputs (PM3255)	11 to 40 V DC, 24 V DC nominal, ≤ 4 mA maximum burden, 3.5 kVrms insulation
<b>Output</b>	
Digital output (PM3210)	Optocoupler, polarity sensitive, 5 to 30 V, 15 mA max, 3.5 kVrms insulation
Digital outputs (PM3255)	Solid state relay, polarity insensitive, 5 to 40 V, 50 mA max, 50 Ω max, 3.5 kVrms insulation

# Power meter series PM3200

## Functions and characteristics (cont.)

Specifications (continued)	PM3200 range
<b>Mechanical characteristics</b>	
Weight	0.57 in (0.26 kg)
IP degree of protection (IEC60529)	IP40 front panel, IP20 meter body
Dimension	3.54 x 3.74 x 2.76 in (90 x 95 x 70 mm)
<b>Environmental conditions</b>	
Operating temperature	-25 °C to 55 °C
Storage temperature	-40 °C to 85 °C
Humidity rating	5 to 95 % RH at 50 °C (non-condensing)
Pollution degree	2
Metering category	III, for distribution systems up to 277/480 V AC
Dielectric withstand	As per IEC61010-1, double-insulated front panel display
Altitude	3000m (984 ft) max
<b>Electromagnetic compatibility</b>	
Electrostatic discharge	Level IV (IEC61000-4-2)
Immunity to radiated fields	Level III (IEC61000-4-3)
Immunity to fast transients	Level IV (IEC61000-4-4)
Immunity to surge	Level IV (IEC61000-4-5)
Conducted immunity	Level III (IEC61000-4-6)
Immunity to power frequency magnetic fields	0.5mT (IEC61000-4-8)
Conducted and radiated emissions	Class B (EN55022)
<b>Safety</b>	
	CE as per IEC61010-1 ★
<b>Communication</b>	
RS-485 port	Half duplex, from 9600 up to 38400 bauds, Modbus RTU (double-insulation)
<b>Display characteristics</b>	
Dimensions (VA)	1.69 x 1.36 in (43 x 34.6 mm)
Display resolution	128 x 96 dots
<b>Standard compliance</b>	
	IEC 61557-12, EN 61557-12 IEC 61010-1, UL 61010-1 IEC 62052-11, IEC 62053-21, IEC 62053-22, IEC 62053-23 EN 50470-1, EN 50470-3

★ Protected throughout by double-insulation



Power meter series PM3250

### Multi-tariff capability

The PM3200 range allows arrangement of kWh consumption in four different registers. This can be controlled by:

- Digital inputs; signal can be provided by PLC or utilities
- Internal clock programmable by HMI
- Through communication

This function allows users to:

- Make tenant metering for dual-source applications to differentiate backup source or utility source
- Understand well the consumption during working time and non-working time, and between working days and weekends
- Follow-up feeders consumption in line with utility tariff rates

BASIC MULTI-FUNCTION METERING

# Power meter series PM3200

## Functions and characteristics



PM3200 top and lower flaps

### PM3200 series dimensions

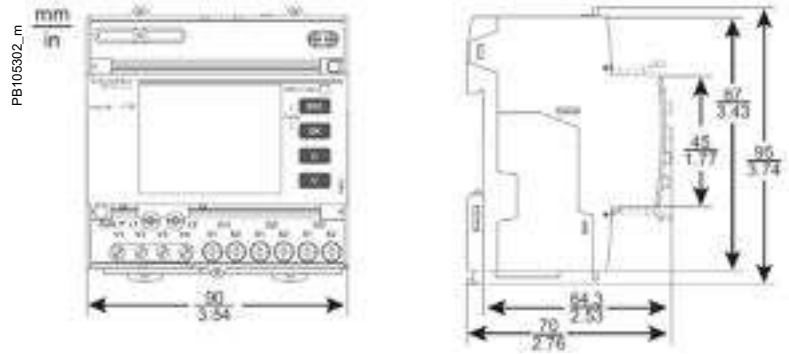

### PM3200 series easy installation

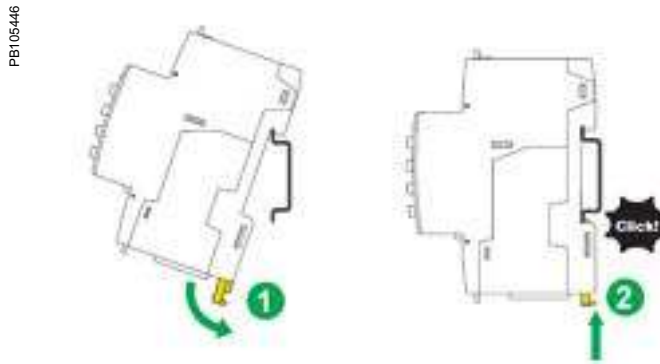

See appropriate product Installation Guide for further information.

BASIC MULTI-FUNCTION METERING

## PM5000 series

The PowerLogic PM5000 series power meters are the new benchmark in affordable, precision metering.

The PowerLogic PM500 is the ideal fit for high-end cost-management applications, providing the measurement capabilities needed to allocate energy usage, perform tenant metering and sub-billing, pin-point energy savings, optimize equipment efficiency and utilization, and perform a high-level assessment of the power quality in an electrical network.

### Applications

Capable of essential cost management:

- Sub-billing/Tenant metering
- Equipment sub-billing
- Energy cost allocation

Also ideal for electrical network management:

- Track real-time power conditions
- Monitor control functions
- Provide basic power quality values
- Monitor equipment and network status



BASIC MULTI-FUNCTION METERING

The solution for

All markets that can benefit from a solution that includes PowerLogic PM5000 series:

- Buildings
- Industry
- Healthcare
- Data centers and networks
- Infrastructure

Benefits

System integrators' benefit

- Ease of integration
- Ease of setup
- Cost effectiveness

Panel builders' benefit

- Ease of installation
- Cost effectiveness
- Aesthetically pleasing
- Simplified ordering

End-users' benefit

- Ease of use
- Precision metering and sub-billing
- Billing flexibility
- Comprehensive, consistent, and superior performance

Competitive advantages

- Easy to install and operate
- Easy for circuit-breaker monitoring and control
- Direct metering of neutral circuit and calculated ground current value to avoid overload and resulting outage (PM556x)
- Power quality analysis
- Load management combined with alarm and timestamping
- High performance and accuracy

Conformity of standards

- |               |                 |
|---------------|-----------------|
| • IEC61557-12 | • IEC 61000-4-2 |
| • IEC62053-22 | • IEC 61000-4-3 |
| • IEC62053-24 | • IEC 61000-4-4 |
| • EN50470-1   | • IEC 61000-4-5 |
| • EN50470-3   | • IEC 61000-4-6 |
| • IEC 61010-1 | • IEC 61000-4-8 |

# PM5000

## Functions and characteristics

PB111777



PowerLogic™ PM5000 series meter

PB111784



PowerLogic™ PM5563 remote display

### PowerLogic PM5100, PM5300, and PM5500 series

The PowerLogic™ PM5000 power meter is the ideal fit for cost-management applications. Designed for use in both energy management systems and building management systems, it provides the measurement capabilities needed to allocate energy usage, perform tenant metering and sub-billing, pin-point energy savings, optimize equipment efficiency and utilization, and perform a high-level assessment of the power quality of the electrical network.

In a single 3.78 x 3.78 in unit, with a graphical display, (plus optional remote display) all three phases, neutral, and ground can be monitored simultaneously. The bright, anti-glare display features large characters and powerful backlighting for easy reading even in extreme lighting conditions and viewing angles.

Easy-to-understand menus, text in eight selectable languages, icons, and graphics create a friendly environment to learn about your electrical network. Ethernet gateway and enhanced cybersecurity are also benefits. These are highly accurate devices with global billing certifications.

### Applications

**Cost management:** Cost-saving opportunities become clear once you understand how and when your facility uses electricity. The PowerLogic PM5000 series meters are ideal for:

- **Sub-billing/Tenant metering:** allows a landlord, property management firm, condominium association, homeowners association, or other multi-tenant property to bill tenants for individual measured utility (electricity) usage. The meters are MID approved for billing applications across Europe.
- **Cost allocation:** Allocate energy costs between different departments (HVAC, indoor and outdoor lighting, refrigeration, etc.), different parts of an industrial process, or different cost centers. Cost-allocation systems can help you save money by making changes to your operation, better maintaining your equipment, taking advantage of pricing fluctuations, and managing your demand.

**Network management:** Improving reliability of the electrical network is key for success in any business. Monitoring values such as voltage levels, harmonic distortion, and voltage unbalance will help you to ensure proper operation and maintenance of your electrical network and equipment. PowerLogic™ PM5000 series meters are the perfect tool for:

- **Basic Power Quality monitoring:** Power quality phenomena can cause undesirable effects such as heating in transformers, capacitors, motors, and generators, and misoperation of electronic equipment and protection devices.
- **Min/Max monitoring (with timestamp):** Understanding when electrical parameters, such as voltage, current, and power demand, reach maximum and minimum values will give you the insight to correctly maintain your electrical network and assure equipment will not be damaged.
- **Alarming:** Alarms help you to be aware of any abnormal behavior on the electrical network in the moment it happens.
- **WAGES monitoring:** Take advantage of the input metering on PM5000 meters to integrate measurements from third-party devices such as water, air, gas, electricity, or steam meters.

# PM5000

## Functions and characteristics (cont.)

PB111777



PowerLogic™ PM5500 meter

### Main characteristics

#### Easy to install

The PM 5000 mounts using two clips, in standard cutout for DIN 3.78 x 3.78 in, no tools required. This is a compact meter with 2.83 in (3.03 in for PM5500) depth, and is connectable up to 690 V L-L without voltage transformers for installations compliant with category III, and has an optional remote display (PM5563), as well as an Ethernet gateway functionality via RS-485 port.

#### Easy to operate

The PM5000 possesses intuitive navigation with self-guided, language-selectable menus, six lines, and four concurrent values. Two LEDs on the meter face help the user confirm normal operation with a green LED-heartbeat/communications indicator and an amber LED – customizable either for alarms or energy pulse outputs. Onboard web pages (PM5500) show real-time and logged information, and verify communications.

#### Easy circuit-breaker monitoring and control

The PM5300 provides two relay outputs (high-performance Form A type) with capability to command most of the circuit breaker coils directly. For digital inputs, monitored switches can be wired directly to the meter without external power supply.

PM5500 series meters have four status inputs (digital) and two digital outputs (solid state) to use for WAGES monitoring, control, and alarm annunciation.

#### Accurate energy measurement for precise cost allocation

	PM5100	PM5300	PM5500
IEC 62053-22 (active energy)	Class 0.5S	Class 0.5S	Class 0.2S

#### Native multi-protocol support

The PM5500 is now easier than ever to integrate into new and existing BMS systems. With native BACnet/IP protocol support, meters can simultaneously communicate via BACnet and Modbus in applications where multiple software systems are used (building management and energy management systems).

The PM5500 series has been tested and certified in accordance with BACnet testing laboratories (BTL) requirements.

#### Direct metering of neutral current

The PM5500 has a fourth CT for measuring neutral current. In demanding IT applications, where loads are non-linear (i.e., switching power supplies on computers/servers), measuring neutral current is essential to avoid overload and resulting outage. In addition, the PM5500 provides a calculated ground current value, not available in meters with 3 CTs.

#### Power Quality analysis

The PM5000 offers total harmonic distortion (THD/thd), total demand distortion (TDD) measurements, and individual harmonics (odds) magnitudes and angles for voltage and current.

	PM5100	PM5300	PM5500
Individual harmonics	Magnitudes up to 15th	Magnitudes up to 31st	Magnitudes and angles up to 63rd

These types of power quality parameters help to identify the source of harmonics that can harm transformers, capacitors, generators, motors, and electronic equipment.

# PM5000

## Functions and characteristics (cont.)

PB11772



PowerLogic™ PM5300 meter

PB11768



PowerLogic™ PM5100 meter

### Load management

Peak demands with timestamping are provided. Predicted demand values can be used in combination with alarms for basic load-shedding applications.

### Alarming with timestamping

A different combination of set point-driven alarms and digital alarms with 1s timestamping are available in the PM5000 family.

	PM5100	PM5300	PM5500
<b>Set point-driven alarms</b>	29	29	29
<b>Unary</b>	4	4	4
<b>Digital</b>	–	2	4
<b>Boolean/logic</b>	–	–	10
<b>Custom defined</b>	–	–	5

Alarms can be visualized as active (both those that have picked up and those that have not yet dropped out) or historical (those that happened in the past). Alarms can be programmed and combined to trigger digital outputs and mechanical relays (PM5300). The PM5000 series keeps an alarm log of active and historical alarms with date and timestamping. SMTP protocol for receiving alarm conditions via email and text, and SNTP protocol for date/time network synchronization are available as well.

### Load timer

A load timer can be set to count load running hours based on a minimum current withdraw adjustable to monitor, and advise maintenance requirements on the load.

### High performance and accuracy

IEC 61557-12 performance measuring and monitoring devices (PMDs) define the performance expectations based on classes. They define the allowable error in the class for real and reactive power and energy, frequency, current, voltage, power factor, voltage unbalance, voltage and current harmonics (odds), voltage THD, current THD, as well as ratings for temperature, relative humidity, altitude, start-up current, and safety. It makes compliant meter readings comparable — they will measure the same values when connected to the same load.

Meets IEC 61557-12 PMD/[SD|SS]/K70/0.5 for PM5100 and PM5300

Meets IEC 61557-12 PMD/[SD|SS]/K70/0.2 for PM5500

### Legal billing compliance

MID compliance is compulsory for billing applications across Europe. In addition to billing applications, for facility managers responsible for energy cost, MID provides the same level of quality as a billing meter.

BASIC MULTI-FUNCTION METERING

# PM5000

## Functions and characteristics (cont.)

### Technical specifications

		PM5100	PM5300	PM5500
Use on LV and MV systems			■	
Basic metering with THD and min/max readings			■	
<b>Instantaneous rms values</b>				
Current	Per phase, neutral and ground (PM5500)		■	
Voltage	Total, per phase L-L and L-N		■	
Frequency			■	
Real, reactive, and apparent power	Total and per phase			Signed, four quadrant
True power factor	Total and per phase			Signed, four quadrant
Displacement PF	Total and per phase			Signed, four quadrant
% Unbalanced I, VL-N, VL-L			■	
Direct monitoring of neutral current				■
<b>Energy values</b>				
Accumulated active, reactive and apparent energy		Received/Delivered; net and absolute; time counters		
<b>Demand value</b>				
Current average		Present, last, predicted, peak, and peak date time		
Active power		Present, last, predicted, peak, and peak date time		
Reactive power		Present, last, predicted, peak, and peak date time		
Apparent power		Present, last, predicted, peak, and peak date time		
Peak demand with timestamping D/T for current and powers			■	
Demand calculation sliding, fixed and rolling block, thermal methods			■	
Synchronization of the measurement window to input, communication command, or internal clock			■	
Settable demand intervals			■	
Demand calculation for pulse input (WAGES)				■
<b>Other measurements</b>				
I/O timer			■	
Operating timer			■	
Load timer			■	
Alarm counters and alarm logs			■	
<b>Power quality measurements</b>				
THD, thd (total harmonic distortion) I, VLN, VLL per phase			I,VLN, VLL 00	
TDD (total demand distortion)			■	
Individual harmonics (odds)		15th	31st	63rd
Neutral current metering with ground current calculation				■
<b>Data recording</b>				
Min/max of instantaneous values, plus phase identification*			■	
Alarms with 1s timestamping*			■	
Data logging			2 selectable parameters kWh and kVAh with configurable interval and duration (e.g., 2 parameters for 60 days at 15-minute intervals)	Up to 14 selectable parameters with configurable interval and duration (e.g., 6 parameters for 90 days at 15-minute intervals)
Memory capacity			256 kB	1.1 MB
Min/max log		■	■	■
Maintenance, alarm, and event logs			■	■
Customizable data logs				■

BASIC MULTI-FUNCTION METERING

# PM5000

## Functions and characteristics (cont.)

Electrical characteristics		PM5100	PM5300	PM5500	
Type of measurement: true rms on three-phase (3P, 3P + N), zero blind		64 samples per cycle		128 samples per cycle	
Measurement accuracy	Active energy	0.5%		0.2%	
	Reactive energy	2%		1%	
	Active power	0.5%		0.2%	
	Apparent power	0.5%			
	Current, phase	0.5%		0.15%	
	Voltage, L-N	0.5%		0.1%	
	Frequency	0.05%			
Measurement accuracy compliance	Measurement accuracy	IEC 61557-12 PMD/[SD]/[SS]/K70/0.5		IEC 61557-12 PMD/[SD]/[SS]/K70/0.2	
	Active energy accuracy	IEC 62053-22 Class 0.2 S ANSI C12.20 Class 0.5		IEC 62053-22 Class 0.2 S ANSI C12.20 Class 0.2	
	Reactive energy accuracy	IEC 62053-23 Class 2			
Input-voltage (up to 1.0 MV AC max, with voltage transformer)	Nominal measured voltage range	20 V L-N / 35 V L-L to 400 V L-N / 690 V L-L absolute range 35 V L-L to 760 V L-L		20 V L-N / 20 V L-L to 400 V L-N/ 690 V L-L absolute range 20 V L-L to 828 V L-L	
	Impedance	5 M Ω			
	F nom	50 or 60 Hz ±2%		50 or 60 Hz ±10%	
Input-current	I nom	1 A or 5 A			
	Measured amps with over range and crest factor	Starting current: 5 mA Operating range: 50 mA to 8.5 A		Starting current: 5 mA Operating range: 50 mA to 10 A	
	Withstand	Continuous 20 A, 10s/hr 50 A, 1s/hr 500 A			
	Impedance	< 0.3 mΩ			
	F nom	50 or 60 Hz ±2%		50 or 60 Hz ±10%	
	Burden	< 0.026 VA at 8.5 A		< 0.024 VA at 10 A	
	Operating range	100-415 V AC +/- 10% CAT III 300V class per IEC 61010		100-480 V AC ±10% CAT III 600V class per IEC 61010	
AC control power	Burden	< 5 W, 11 VA at 415 V L-L		< 5W/16.0 VA at 480 V AC	
	Frequency	45 to 65 Hz			
	Ride-through time	80 mS typical at 120 V AC and maximum burden 100 mS typical at 230 V AC and maximum burden 100 mS typical at 415 V AC and maximum burden		35 ms typical at 120 V L-N and maximum burden 129 ms typical at 230 V L-N and maximum burden	
	Operating range	125-250 V DC ±20%			
DC control power	Burden	4 W max at 125 V DC		typical 3.1 W at 125 V DC, max 5W	
	Ride-through time	50 mS typical at 125 V DC and maximum burden			
	Outputs	Relay	Max output frequency	0.5 Hz maximum (1 second ON/1 second OFF— minimum times)	
Switching current			250 V AC at 8.0 amps, 25 k cycles, resistive 30 V DC at 2.0 amps, 75 k cycles, resistive 30 V DC at 5.0 amps, 12.5 k cycles, resistive		
Isolation			2.5 kV rms		
Digital outputs			1	2	2
		Max load voltage	40 V DC		30 V AC/60 V DC
		Max load current	20 mA		125 mA
		On resistance	50 Ω max		8 Ω
		Meter constant	from 1 to 9,999,999 pulses per kWh k_h (configurable for delivered or received or delivered + received energy for kWh or kVARh or kVAh)		
		Pulse width for digital output	50% duty cycle		
		Pulse frequency for digital output	25 Hz max		
		Leakage current	0.03 microamps		1 microamps
Isolation		5 kV rms		2.5 kV rms	
Optical outputs					
		Pulse width (LED)	200 microseconds		
		Pulse frequency	50 Hz. max		2.5 kHz. max
	Meter constant	from 1 to 9,999,999 pulses per kWh k_h (configurable for delivered or received or delivered + received energy for kWh or kVARh or kVAh)			

# PM5000

## Functions and characteristics (cont.)

Electrical characteristics (cont.)		PM5100	PM5300	PM5500
Status inputs	ON voltage		18.5 to 36 V DC	30 V AC/60 V DC max
	OFF voltage		0 to 4 V DC	
	Input resistance		110 k Ω	100 k Ω
	Maximum frequency		2 Hz (T ON min = T OFF min = 250 mS)	25 Hz (T ON min = T OFF min = 20 mS)
	Response time		20 mS	10 mS
	Opto isolation		5 kV RMS	2.5 kV RMS
	Whetting output		24 V DC/8 mA max	
	Input burden		2 mA @ 24 V DC	2 mA @ 24 V AC/DC
<b>Mechanical characteristics</b>				
Product weight		380 g	430 g	450 g
IP degree of protection (IEC 60529)		IP52 front display, IP20 meter body		
Dimensions W x H x D [protrusion from cabinet] ★		3.78 x 3.78 x 2.83 in (96 x 96 x 72 mm) (3.03 in [77mm] for PM5500) (depth of meter from housing mounting flange) [0.51 in (13 mm)]		
Mounting position ★		Vertical		
Panel thickness		0.24 in (6 mm) maximum		
<b>Environmental characteristics</b>				
Operating temperature	Meter	-25 °C to 70 °C		
	Display (display functions to -25° with reduced performance)	-25 °C to 70 °C		
Storage temperature		-40 °C to 85 °C		
Humidity range		5 % to 95 % RH at 37°C (non-condensing)		
Pollution degree		2		
Altitude		2000 m CAT III/3000 m CAT II	3000 m max CAT III	
<b>Electromagnetic compatibility ★★</b>				
Harmonic current emissions		IEC 61000-3-2		
Flicker emissions		IEC 61000-3-3		
Electrostatic discharge		IEC 61000-4-2		
Immunity to radiated fields		IEC 61000-4-3		
Immunity to fast transients		IEC 61000-4-4		
Immunity to surge		IEC 61000-4-5		
Conducted immunity 150kHz to 80MHz		IEC 61000-4-6		
Immunity to magnetic fields		IEC 61000-4-8		
Immunity to voltage dips		IEC 61000-4-11		
Radiated emissions		FCC part 15, EN 55022 Class B		
Conducted emissions		FCC part 15, EN 55022 Class B		

★ PM5563 is DIN mounted

★★ Tests are conducted as per IEC 61557-12 (IEC 61326-1), 62052-11, and EN 50470

# PM5000

## Functions and characteristics (cont.)

Safety	PM5100	PM5300	PM5500		
Europe	CE, as per IEC 61010-1 Ed. 3, IEC 62052-11 and IEC 61557-12				
U.S. and Canada	cULus as per UL61010-1 (3rd Edition)				
Measurement category (voltage and current inputs)	CAT III up to 400 V L-N / 690 V L-L				
Dielectric	As per IEC/UL 61010-1 (3rd edition)				
Protective class	II, double insulated for user-accessible parts				
<b>Communication</b>					
RS-485 port Modbus RTU, Modbus ASCII (7 or 8 bit), JBUS	2-Wire, 9600,19200 or 38400 baud, Parity even, odd, or none, 1 stop bit if parity odd or even, 2 stop bits if none; (optional in PM51x and PM53x)				
Ethernet port: 10/100 Mbps; Modbus TCP/IP		1 optional	2 (for daisy chain only, one IP address); BACnet/IP		
Firmware and language file update	Meter firmware update via the communication ports				
Isolation	2.5 kVrms, double insulated				
<b>Human machine interface</b>					
Display type	Monochrome graphics LCD				
Resolution	128 x 128				
Backlight	White LED				
Viewable area (W x H)	2.64 x 2.46 in (67 x 62.5 mm)				
Keypad	4-button				
Indicator heartbeat/comm activity	Green LED				
Energy pulse output/active alarm indication (configurable)	Optical, amber LED				
Wavelength	590 to 635 nm				
Maximum pulse rate	2.5 kHz				
	<b>PM5100</b>	<b>PM5300</b>	<b>PM5500</b>		
Short reference numbers	PM5110	PM5330	PM5340	PM5560	PM5563
<b>Installation</b>					
Fast panel mount with integrated display	■	■	■	■	-
Remote display (optional)	-	-	-	-	■
Fast installation, DIN rail mountable	-	-	-	-	■
<b>Accuracy</b>	<b>CL 0.5S</b>	<b>CL 0.5S</b>	<b>CL 0.5S</b>	<b>CL 0.2S</b>	<b>CL 0.2S</b>
<b>Display</b>					
Backlit LCD, multilingual, bar graphs, 6 lines, 4 concurrent values	■	■	■	■	■
<b>Power and energy metering</b>					
3-phase voltage, current, power, demand, energy, frequency, power factor	■	■	■	■	■
Multi-tariff	-	4	4	8	8
<b>Power quality analysis</b>					
THD, thd, TDD	■	■	■	■	■
Harmonics, individual (odd) up to	15th	31st	31st	63rd	63rd
<b>I/Os and relays</b>					
I/Os	1DO	2DI/2DO	2DI/2DO	4DI/2DO	4DI/2DO
Relays	0	2	2	0	0
<b>Alarms and control</b>					
Alarms	33	35	35	52	52
Set point-response time, seconds	1	1	1	1	1
Single and multi-conditional alarms	-	■	■	■	■
Boolean alarm logic	-	-	-	■	■
<b>Communications</b>					
Serial ports with Modbus protocol	1	1	-	1	1
Ethernet port with Modbus TCP protocol	-	-	1	2 ★	2 ★
Ethernet port with BACnet/IP protocol ★	-	-	-	2 ★★	2 ★★
Ethernet-to-serial-gateway	-	-	-	■	■
Onboard web server with web pages	-	-	-	■	■

★ Ability to simultaneously communicate via Modbus TCP/IP and BACnet/IP.  
 ★ ★ 2 Ethernet ports for daisy chain, one IP address. Ability to simultaneously communicate via Modbus TCP/IP and BACnet/IP.

# PM5000

## Dimensions and connection

Commercial reference numbers	
Part description	Commercial ref. no.
PM5300 power meter, serial + 2DI-2DO-2relay out	METSEPM5330
PM5300 power meter, serial + 2DI-2DO-2relay out, MID	METSEPM5331
PM5300 power meter, ETH + 2DI-2DO-2relay out	METSEPM5340
PM5300 power meter, ETH + 2DI-2DO-2relay out, MID	METSEPM5341
PM5560 power meter, ETH-serial + 4DI-2DO out	METSEPM5560
PM5561 power meter, ETH-serial + 4DI-2DO out, MID	METSEPM5561
PM5563 power meter, ETH-serial + 4DI-2DO out, no display	METSEPM5563 <sup>(1)</sup>
PM5500 power meter, ETH-serial + 4DI-2DO out, remote display	METSEPM5563RD <sup>(1)</sup>
Remote display for PM5563 power meter	METSEPM5RD <sup>(1)</sup>
Hardware kit for PM51XX (voltage, current, comms, and IO connectors + moulding clips)	METSEPM51HK
Hardware kit for PM53XX (voltage, current, comms, and IO connectors + moulding clips)	METSEPM53HK
Revenue sealing kit for PM51XX & PM53XX (sealing covers for voltage + current connectors)	METSEPM51-3RSK
Hardware kit for PM55XX (voltage, current, comms, and IO connectors, + moulding clips)	METSEPM55HK
Revenue sealing kit for PM55XX (sealing covers for voltage + current connectors)	METSEPM55RSK

(1) METSEPM5563RD includes both METSEPM5563 and METSEPM5RD

BASIC MULTI-FUNCTION METERING

# PM5000

## Dimensions and connection (cont.)

**PM5000 series meter flush mounting\***

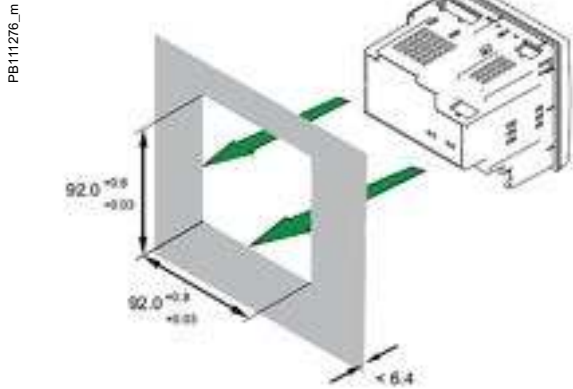

**PM5000 series meter dimensions**

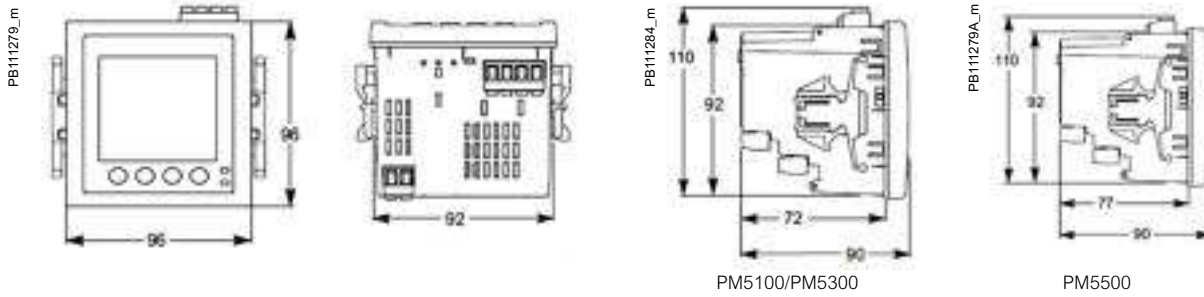

**PM5000 series remote display dimensions**

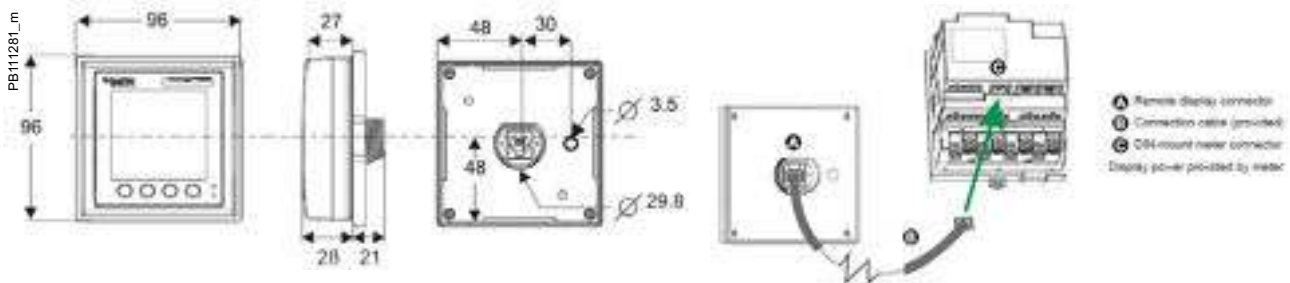

**PM5000 series meter parts**



- PM5000 meter parts**
- A** Menu selection buttons
  - B** LED indicators
  - C** Navigation or menu selections
  - D** Maintenance and alarm notification area

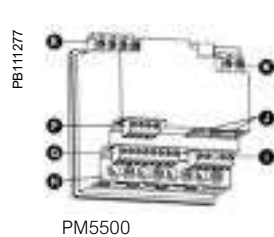

- PM5500 meter parts**
- E** Voltage inputs
  - F** RS-485 comms
  - G** Digital inputs
  - H** Current inputs
  - I** Digital outputs
  - J** Ethernet ports
  - K** Control power

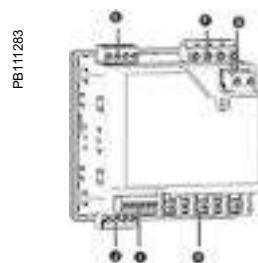

- PM5100/PM5300 meter parts**
- E** Relay output (PM5300 only)
  - F** Voltage inputs
  - G** Control power
  - H** Current inputs
  - I** Status inputs/digital outputs
  - J** Communications port: Ethernet (PM5300 only) or RS-485

NOTES

---

BASIC MULTI-FUNCTION METERING

# ION6200

The PowerLogic ION6200 series meter is a low-cost, highly accurate, and flexible power and energy meter with outstanding quality, versatility, and function. Simple to use, easy to wire and mount, the meter features a compact design and modular architecture for scalability.

**Applications:**

- Basic power and energy meter for feeders, loads, or tenant space
- Analysis of efficiency, losses, and capacity
- Cost allocation and submetering
- Demand or power factor management
- Stand-alone metering
- Replace multiple analog meters



PowerLogic ION6200

## BASIC MULTI-FUNCTION METERING

### The solution for

Markets that can benefit from a solution that includes ION6200 series meters

- Buildings
  - Multi-tenant facilities
  - Healthcare
  - Data centers
- 

### Benefits

- Improve energy efficiency
  - Improve operations
  - Reduce energy-related costs
  - Optimize equipment use
- 

### Competitive advantages

- Compact, scalable energy-management solution
- Easily integrates with existing energy-management systems and RTUs
- Patented ION technology

### Conformity of standards

- IEC 60687 Class 0.5
- ANSI 12.20 Class 0.5
- IEC 61000-4-2 (EN61000-4-2/IEC801-2)
- IEC 61000-4-3 (EN61000-4-3/IEC801-3)
- IEC 61000-4-4 (EN61000-4-4/IEC801-4)
- IEC 61000-4-5 (EN61000-4-5/IEC801-5)
- IEC 61000-4-6 (EN61000-4-6/IEC801-6)
- IEC 61000-6-2
- IEC1010-1 (EN61010-1)

# ION6200

## Functions and characteristics

### Main characteristics

#### High visibility front panel display

The ION6200 displays all basic power parameters on a bright LED display with twelve 0.75 in high digits.

#### Megawatt option

The Megawatt option displays all power and energy values in millions (e.g., megawatts) and volts in thousands (kilovolts), using a different front panel faceplate than the standard meter, with labels for kV, MW, MVA, Mvar, MWh, MVAh and Mvarh.

#### Complete communications

Optional RS 485 port with standard Modbus RTU and ION compatible protocol; data rates from 1,200 bps to 19,200 bps.

#### Modularity

The ION6200's modular construction allows for simple retrofit, allowing you to save money by making a low initial investment that can be upgraded to meet future needs.

#### Easy to use

Fast setup via display or software, free configuration software, and a bright, easy-to-read LED display make the ION6200 easy to use.

#### Accuracy certification

This meter offers IEC 60687 Class 0.5S accuracy for use as a tariff meter.

#### Revenue metering option

Provides power and energy measurements that are certified for revenue metering and protection against unauthorized alteration of these measured quantities.

#### Flexible architecture

Patented ION® technology provides a modular, flexible architecture that offers extensive user programmability. It uniquely addresses complex monitoring and control applications, and adapts to changing needs, avoiding obsolescence.

#### Multiple installation options

Supports direct four-wire wye, three-wire wye, three-wire delta, direct delta, and single-phase configurations.

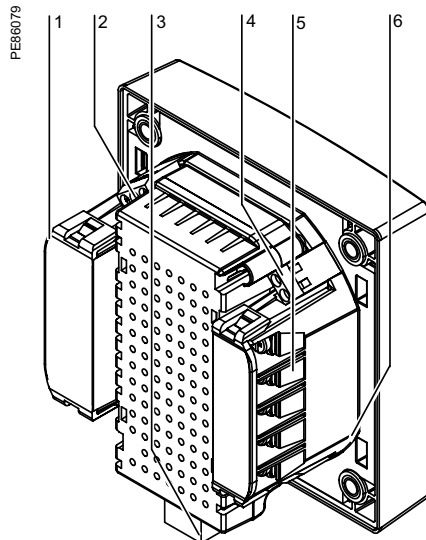

- 1 Current inputs
- 2 COM1 port
- 3 Power supply
- 4 D2: Form A digital out
- 5 Voltage inputs
- 6 D1: Form A digital out

Selection guide		ION6200 Standard	ION6200 EP #1*	ION6200 EP #2*
<b>General</b>		(N)	(P)	(R)
Use on LV and HV systems		■	■	■
Current and voltage accuracy <sup>(1)</sup>		0.3%	0.3%	0.3%
Energy and power accuracy		0.5%	0.5%	0.5%
Number of samples per cycle		64	64	64
<b>Instantaneous RMS values</b>				
Current and voltage <sup>(2)</sup>		■	■	■
Frequency		-	■	■
Active power	Total	-	■	■
	Per phase	-	-	■
Reactive and apparent power	Total	-	-	■
	Per phase	-	-	■
Power factor	Total	-	■	■
	Per phase	-	-	■
<b>Energy values</b>				
Active energy <sup>(3)</sup>		-	■	■
Reactive, apparent energy <sup>(3)</sup>		-	-	■
<b>Demand values</b>				
Current	Present and max	-	■	■
Active power	Present	-	-	■
	Max	-	■	■
Reactive and apparent power	Present and max	-	-	■
<b>Power quality measurements</b>				
Harmonic distortion <sup>(2)</sup>	Current, voltage	-	-	■
<b>Display and I/O</b>				
LED display		■	■	■
Pulse output		■	■	■
Direct voltage connection (V ac)		400/690	400/690	400/690
<b>Communication</b>				
RS-485 port		■	■	■
ION compatibility		■	■	■
Modbus RTU protocol		■	■	■

(\* EP = 'enhanced package.'

(1) For L-N only. L-L = 0.5% reading accuracy.

(2) Some values not available when volts mode is set to delta or direct delta.

(3) Additional energy values available on standard and EP #1 models through pulse output.

# ION6200

## Functions and characteristics (cont.)

PE86127



PowerLogic ION6200

Electrical characteristics		
Type of measurement	True RMS electrical parameters Up to 64 samples per cycle	
Measurement accuracy	Current $\geq 5\%$ of full scale	0.3% reading
	$< 5\%$ of full scale	0.3% reading + 0.05% full scale
	I4 derivation	0.6% reading + 0.05% full scale
	Voltage	L-N 0.3% reading, L-L 0.5% reading
Power	IEC 60687 Class 0.5 ANSI 12.20 Class 0.5	
Frequency	0.1% reading	
Power factor	1.0% reading	
Energy	IEC 60687 Class 0.5 ANSI 12.20 Class 0.5	
Harmonic distortion	Total harmonic distortion $\pm 1.0\%$	
Input-voltage characteristics	Measured voltage <sup>(1)</sup>	60-400 LN (103.5-690 LL) V ac RMS (3-phase) 60-400 LN V ac (single-phase)
	Measurement range	60-400 LN V ac
	Impedance	2 M $\Omega$ /phase
	Inputs	V1, V2, V3, Vref
	Overload	1500 V ac RMS continuous
	Dielectric withstand	>3250 V ac RMS; 60 Hz for 1 minute
Input-current characteristics	Rated inputs <sup>(1)</sup>	5 A nominal/10 A full scale RMS (+20% overrange with full accuracy, 300 V RMS to ground)
	Permissible overload	120 A RMS for 1 second, non-recurring
	Starting current	0.005 A RMS
	Burden	0.05 VA (typical) @ 5 A RMS
	Inputs	I1, I2, I3
	Dielectric withstand	3000 V RMS for 1 minute
Power supply	AC	Standard: 100-240 V ac, 50-60 Hz
	DC	Standard: 110-300 V dc Low voltage DC: 20-60 V dc
Input/outputs	Digital outputs	2 optically isolated digital outputs for KY pulsing or control Max forward current: 150 mA Max voltage: 200 V Max current: 150 mA
	RS-485 port	Optically isolated
Mechanical characteristics		
Weight	1.5 lb (0.68 kg) (shipping)	
IP degree of protection (IEC 60529)	Meter with display: front IP 65, back IP 30 Transducer unit (no integrated display): IP 30 Remote display unit: front IP 65, back IP 30	
Dimensions	Basic unit installed depth: 4.20 x 4.20 x 1.60 in (106.7 x 106.7 x 40.6) Remote display: 4.2 x 4.2 x 0.90 in (106.7 x 106.7 x 22.9 mm)	
Environmental conditions		
Operating temperature	-20 °C to 70 °C ambient air	
Storage temperature	-40 °C to 85 °C	
Humidity rating	5% to 95% non-condensing	
Pollution degree	2	
Installation category	III (Distribution)	
Electromagnetic compatibility		
Electrostatic discharge	IEC 61000-4-2 (EN61000-4-2/IEC801-2)	
Immunity to radiated fields	IEC 61000-4-3 (EN61000-4-3/IEC801-3)	
Immunity to fast transients	IEC 61000-4-4 (EN61000-4-4/IEC801-4)	
Surge immunity	IEC 61000-4-5 (EN61000-4-5/IEC801-5)	
Conducted immunity	IEC 61000-4-6 (EN61000-4-6/IEC801-6)	
Electromagnetic compatibility for industrial environments	IEC 61000-6-2	
Safety		
	cUL compliant to CSA C22.2 No. 1010-1 IEC1010-1 (EN61010-1) UL 3111-1	
Communications		
RS 485 port	Up to 19 200 bps, Modbus RTU, ION-compatible protocol	
Display characteristics		
Bright LED display	0.75 in (19 mm) high digits Displays all basic power parameters Easy setup for common configuration parameters Password protection on setup parameters Password protection for demand reset	

(1) The meter inputs can be used with PTs that have secondaries rated between 50 V ac and 347 V ac +25%. Use CTs that are compliant with the electrical safety code in your region.

# ION6200

## Functions and characteristics (cont.)

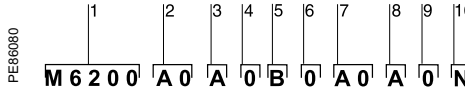

Example product part number

- 1 Model
- 2 Form factor
- 3 Current inputs
- 4 Voltage inputs
- 5 Power supply
- 6 System frequency
- 7 Communications
- 8 Onboard inputs/outputs
- 9 Security
- 10 Measurement package

PE66081



Part numbers		
Item	Code	Description
1 Model	M6200	ION6200 Meter Kit: ION6200 meter base, options card, and power supply
2 Form factor	A0	Integrated display model
	R1	Transducer model with DIN rail mount, remote display and 14-ft cable (RJ11, 6 conductor, 26 gauge)
	R2	Transducer model with DIN rail mount, remote display and 6-ft cable (RJ11, 6 conductor, 26 gauge)
	R3	Transducer model with DIN rail mount, remote display and 30-ft cable (RJ11, 6 conductor, 26 gauge)
3 Current inputs	T1	Transducer model with DIN rail mount (requires comms or pulse outputs)
	A	10 amp current inputs (12 amp max)
	0	Autoranging (57-400 V ac L-N / 99-690 V ac L-L)
	0	Calibrated for use with 50 Hz or 60 Hz systems
4 Voltage inputs	Z0	No communications
	A0	Single RS-485 port (supports Modbus RTU protocol and ION-compatible PML protocol)
6 System Frequency	A	No I/O
	B	This option activates the two Form A digital outputs for kWh, kvarh energy pulsing
7 Communications	0	No hardware lock (setup is password protected)
	2	RMANSI: revenue meter approved for use in the U.S (ANSI C12.16 approved; meets ANSI C12.20 Class 0.5 accuracy at 23°C; 10A current inputs only)
	3	RMICAN: measurement Canada approved revenue meter for use in Canada (10A current inputs only)
	4	**RMICAN-SEAL: factory-sealed and Measurement Canada approved revenue meter
8 I/O	N	Standard measurements (volts/amps per phase and avg)
	P	Enhanced package #1 (standard measurements plus energy/power total, frequency, power factor total, neutral current)
	R	Enhanced package #2 (all measurements)
9 Security	<b>Power supply</b>	
	P620PB	Standard plug-in power supply (100–240 V AC/50–60 Hz or 110–300 V DC)
	P620PC	Low voltage DC plug-in power supply (20-60 V DC)
10 Measurement package	<b>Part numbers</b>	
	<b>PowerLogic ION6200 meters</b>	
	PowerLogic ION6200	M6200

# ION6200

## Functions and characteristics (cont.)

PE66082



PE66083



### Megawatt options

Megawatt option on meter base with integrated display; not available for RMICAN or RMICAN-sealed meters	M0
Megawatt option on transducer model with DIN rail mount, remote Display and 14-ft cable (RJ11, 6 conductor, 26 gauge); not available with Security options RMICAN or RMICAN-SEAL	N1
Megawatt option on transducer model with DIN rail mount, Remote display and 6-ft cable (RJ11, 6 conductor, 26 gauge); not available with security options RMICAN or RMICAN-SEAL	N2
Megawatt option on transducer model with DIN rail mount, remote display and 30-ft cable (RJ11, 6 conductor, 26 gauge); not available with security options RMICAN or RMICAN-SEAL	N3

### Options card

1	Standard measurements	Z0A0N
2	Enhanced package #1	Z0A0P
3	Enhanced package #2	Z0A0R
4	Standard measurements, two pulse outputs	Z0B0P
5	Enhanced package #1, two pulse outputs	Z0B0P
6	Enhanced package #2, two pulse outputs	Z0B0R
7	Standard measurements, RS-485	A0A0N
8	Enhanced package #1, RS-485	A0A0P
9	Enhanced package #2, RS-485	A0A0R
10	Standard measurements, two pulse outputs, RS-485	A0B0N
11	Enhanced package #1, two pulse outputs, RS-485	A0B0P
12	Enhanced package #2, two pulse outputs, RS-485	A0B0R

### Remote modular display (RMD)

Model	M620D	
Display Type	Standard display	R
	Megawatt option – for use with transducer meter base with megawatt option	N
Cable Length	No cable	0
	14-ft cable for connecting remote display unit to the ION6200 transducer meter base	1
	6-ft cable for connecting remote display unit to the ION6200 transducer meter base	2
	30-ft cable for connecting remote display unit to the ION6200 transducer meter base	3

### Cables for remote modular display

14-ft cable for connecting remote display unit to the ION6200 transducer meter base	P620C1
6-ft cable for connecting remote display unit to the ION6200 transducer meter base	P620C2
30-ft cable for connecting remote display unit to the ION6200 transducer meter base	P620C3

BASIC MULTI-FUNCTION METERING

# ION6200

## Functions and characteristics (cont.)

### ION6200 integrated model dimensions

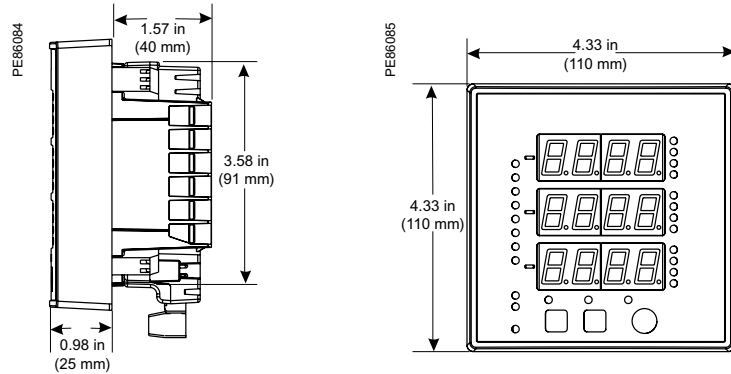

### ION6200 TRAN model dimensions

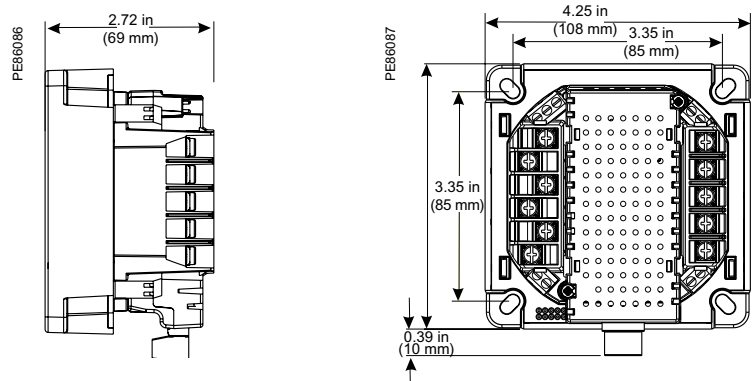

### ION6200 RMD dimensions

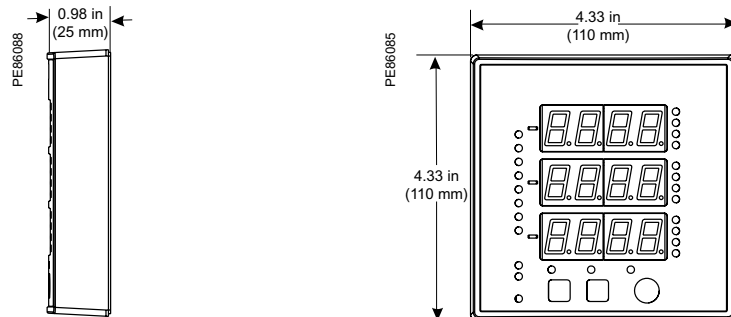

BASIC MULTI-FUNCTION METERING

# ION6200

## Functions and characteristics (cont.)

### Mounting integrated model – ANSI 4" (4 1/2" switchboard)

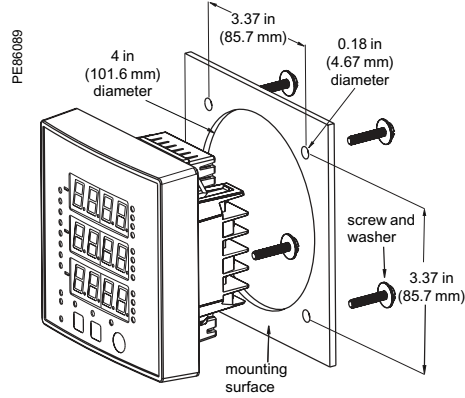

### Mounting integrated model – DIN 96

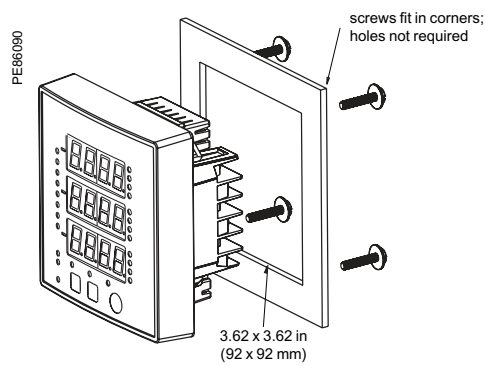

### Mounting the TRAN model

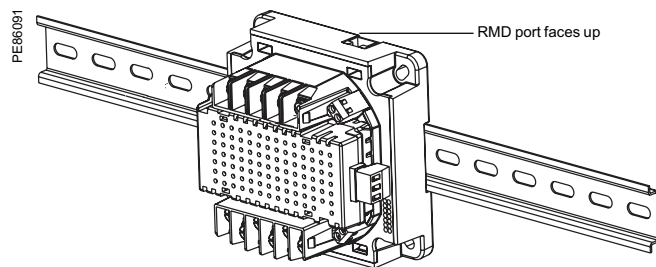

BASIC MULTI-FUNCTION METERING

# EM3500

The EM3500 series DIN rail meter combines exceptional performance and easy installation to deliver a cost-effective solution for power-monitoring applications. This compact, affordable series of DIN-mounted meters offers versatility and flexibility for system integration.

## Applications:

- Energy monitoring in building automation systems
- Renewable energy monitoring
- Energy management
- Commercial submetering
- Industrial monitoring
- Cost allocation



PowerLogic™ EM3500

## BASIC MULTI-FUNCTION METERING

### The solution for

All markets that can benefit from a solution that includes EM3500 series meters:

- Buildings
  - Healthcare
  - Data centers
- 

### Benefits

- Reduce energy consumption and save on utility bills
  - Make informed load-shifting and shedding decisions
  - Measure power data and demand
  - Optimize equipment use
- 

### Competitive advantages

- Compact, scalable energy-management solution
- Easily integrates with existing energy-management systems and RTUs
- Patented ION technology

### Conformity of standards

- ANSI C12.20 0.5% accuracy, IEC 62053-22 Class 0.5S
- ANSI C12.20 0.2% accuracy, IEC 62053-22 Class 0.2S

BASIC MULTI-FUNCTION METERING

# EM3500

## Functions and characteristics

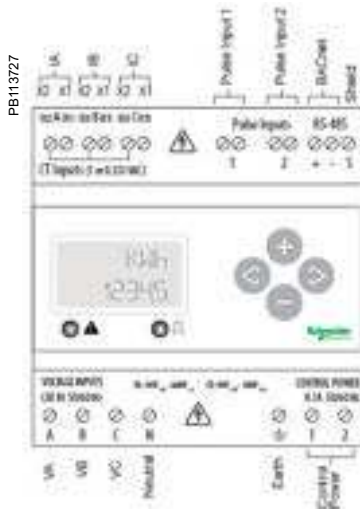

EM3555 models: an essential solution for solar and other renewable energy applications

- Bi-directional metering (4-quadrant); allows net metering
- Data-logging capability; ensures long-term data retrieval
- CSI approved

Model	Description	Part Numbers
EM3502	Pulse out only	METSEEM3502
EM3550	Modbus – two-quadrant	METSEEM3550
EM3555	Modbus – four-quadrant with logging	METSEEM3555
EM3560	BACnet with logging	METSEEM3560
EM3502A	Pulse rope CT model	METSEEM3502A
EM3550A	Modbus rope CT model	METSEEM3550A
EM3560A	BACnet w/logging rope CT model	METSEEM3560A
EM3561	BACnet without logging	METSEEM3561
EM3561A	BACnet without logging rope CT model	METSEEM3561A

EM3500 parts and connection terminals

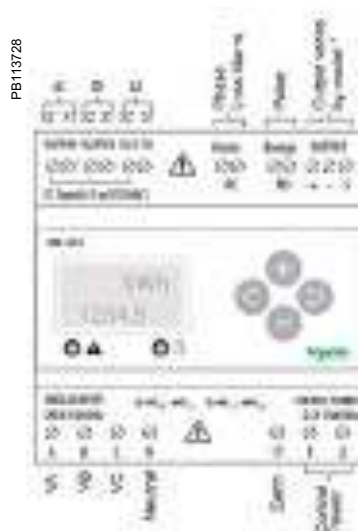

EM3502/EM355x parts and connection terminals

# EM3500

## Functions and characteristics (cont.)

### Features

All models: a compact solution for panelboard monitoring

- DIN rail-mounting option; easy installation
- ANSI 12.20 0.2% accuracy, IEC 62053-22 Class 0.2S for all 35xx models; great for cost allocation
- ANSI C12.20 0.5% accuracy, IEC 62053-22 Class 0.2S for EM35xxA models
- Real energy output and phase loss alarm output on EM3502(A), EM3550(A), and EM3555 models; one device serves multiple applications
- 90-600 VAC; application versatility with fewer models to stock
- Bright backlit LCD; easy visibility in dark enclosures
- Data-logging capability EM3555 and EM3560(A); safeguard during power failures
- EM35xx models compatible with LVCTs from 5A to 32000A; wide range of service types
- User-enabled password protection; prevents tampering
- EM35xxA models are designed to work exclusively with U018 Rope Style CTs 50-5000A range; eliminate site walks, and save time and money (Not recommended in high-harmonic applications)
- System integration via Modbus EM355xx(A) or BACnet MS/TP EM356xx(A); convenient compatibility with existing systems
- Native BACnet MS/TP support (no gateway) with serial rates up to 115.2 kbaud for EM3560, EM3561, EM3560A, and EM3561A



EM3500 in enclosure

Technical specifications		
Electrical characteristics		
Inputs	Control power, AC	50/60 Hz; 5 VA max.; 90 V min.; UL maximums: 600 V L-L (347V L-N); CE maximums: 300 V L-N (520V L-L )
	Control power, DC	3W max.; UL and CE: 125 to 300 V DC (external DC current limiting required)
	Voltage input	UL: 90 V L-N to 600 V L-L; CE: 90 V L-N to 300 V L
Current input	Scaling	5 A to 32,000 A non-A models only 50 A to 5000 A for A models only
	input range	1/3V and 1V nominal LVCT (selectable) Non-A models only U018 CTs only for A models
Pulse Inputs (EM3560 and EM3560A)		Two sets of contact inputs to pulse accumulators
	(EM3561 and EM3561A)	One set of contact inputs pulse accumulators
Accuracy	Real power and energy	0.2% (ANSI C12.20, IEC 62053-22 Class 0.2S) EM35xx models only 0.5% (ANSI C12.20, IEC 62053-22 Class 0.5S) EM35xx models only
Outputs	All models (EM3560, EM3560A, EM3561 and EM3561A)	Real energy pulse: N.O. static; alarm contacts: N.C. static
	EM3502	Reactive energy pulse 30 VAC/DC
	EM3550, EM3555, EM3550A	RS-485 two-wire Modbus RTU (1200 baud to 38.4 kbaud)
	EM3560, EM3560A, EM3561, EM3561A	RS-485 2-wire BACnet MS/TP (9600 baud to 115.2 kbaud)
Mechanical characteristics		
Mounting	DIN rail or 3-point screw mount	
Environmental conditions		
Operating temperature range	-30 °C to 70 °C (-22 °F to 158 °F)	
Storage temperature range	-40 °C to 85°C (-40 °F to 185 °F)	
Humidity range	< 95 % RH non-condensing	
Accessories		
NEMA 4x enclosure (EM3500-ENC, pictured)		
Split-core low-voltage CTs (LVCTxx)		
Fuse kits (EFP1, EFP2, EFP3)		
Safety		
U.S. and Canada (cULus) UL508 (open type device)/CSA 22.2 No. 14-05		
Europe (CE) EN61010-1:2001		

# EM3500

## Functions and characteristics (cont.)

Measurement capability, full data set	EM3502	EM3550	EM3560	EM3561	EM3555	EM3502A	EM3550A	EM3560A	EM3561A
Bi-directional energy measurements					■				
Power (3-phase total and per phase): real (kW) reactive (kVAR), and apparent (kVA)	■	■	■	■	■	■	■	■	■
Power factor: 3-phase average and per phase	■	■	■	■	■	■	■	■	■
Present power demand: real (kW), reactive (kVAR), and apparent (kVA)	■	■	■	■	■	■	■	■	■
Import and export totals of present power demand: real (kW), reactive (kVAR), and apparent (kVA)					■				
Peak power demand: real (kW), reactive (kVAR), and apparent (kVA)	■	■	■	■	■	■	■	■	■
Current (three-phase average and per phase)	■	■	■	■	■	■	■	■	■
Voltage: line-line and line-neutral (three-phase average and per phase)	■	■	■	■	■	■	■	■	■
Frequency	■	■	■	■	■	■	■	■	■
ANSI C12.20 0.5 % accuracy, IEC 62053-22 Class 0.5S						■	■	■	■
ANSI C12.20 0.2 % accuracy, IEC 62053-22 Class 0.2S	■	■	■	■	■				
Accumulated net energy: real (kWh), reactive (kVARh), and apparent (kVAh)	■	■	■	■	■	■	■	■	■
Accumulated real energy by phase (kWh)	■	■	■	■	■	■	■	■	■
Import and export accumulators of real and apparent energy					■				
Reactive energy accumulators by quadrant (three-phase total & per phase)					■				
Demand interval configuration: fixed or rolling block	■	■	■	■	■	■	■	■	■
Demand interval configuration: external sync to comms		■	■	■	■		■	■	■
<b>Data logging (store up to 60 days at 15-minute intervals)</b>									
Data logging: 10 16-bit configurable (can include date/time) data buffers					■				
Data logging: 3 timestamped 32-bit configurable data buffers			■					■	
<b>Outputs</b>									
Alarm output (N.C.)	■	■	■		■	■	■	■	■
1-pulse output (N.O.)		■			■	■			
2-pulse outputs (N.O.)	■					■			
RS-485 serial (Modbus RTU protocol)		■			■		■		
RS-485 serial (BACnet MS/TP protocol)			■	■				■	■
LON FT serial (LonTalk protocol)									
<b>Inputs</b>									
2-pulse contact accumulator inputs			■						■
1-pulse contact accumulator input				■					■



BASIC MULTI-FUNCTION METERING

# EM3500

## Functions and characteristics (cont.)

### EM3500 dimensions

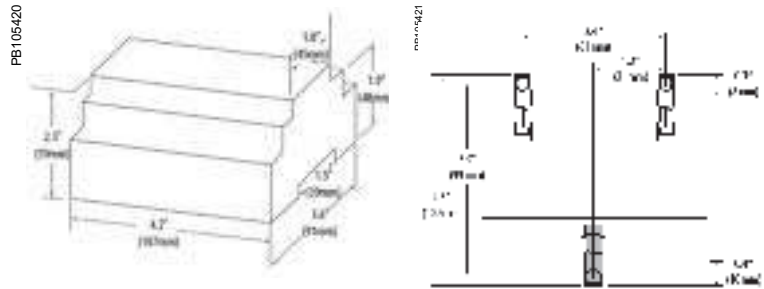

### EM3500 dimensions

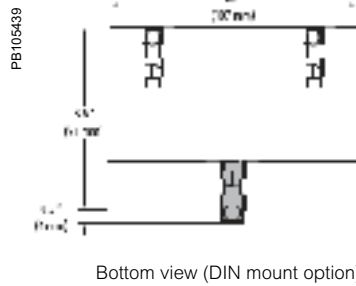

### EM3500 connections

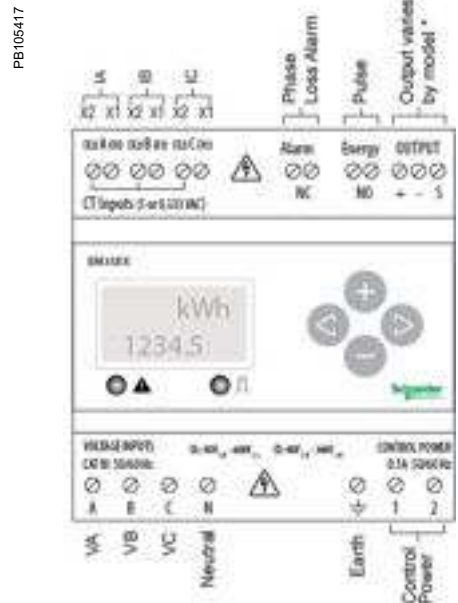

Two five-character rows of display text;  
Top row alphanumeric;  
bottom row numeric only

The red Alarm LED lights when any of the three-phase voltages drop below the selected threshold

The green Energy LED lights momentarily each time the Energy output pulse is active

Please see EM3500 User Guide and EM3500 Installation Guide for safe and correct wiring and connection information.

BASIC MULTI-FUNCTION METERING

# EM4200 series

The PowerLogic EM4200 Series Enercept power and energy meters provide a unique solution for measuring energy data. Designed with the user in mind, the EM4200 series offers maximum application flexibility for retrofit applications.

Designed for simplicity, the range includes two main offers: System Calibrated and Flex.

The EM4200 System Calibrated offers system accuracy, pre-mounted Current Transducers, with a simple to quote and order single part number.

The EM4200 Flex offers the flexibility of a wide range of Current Transducers to match most applications, no matter how varied.

With 75 percent of the buildings that will be occupied in 2050 having already been built, and a large number of those not meeting today's strict energy codes and standards, a metering solution that can be easily installed and integrated into existing buildings is imperative. The EM4200 Series Enercept brings industry-leading flexibility to power and energy monitoring, making it the ideal meter for retrofit applications.

## Applications

Capable of essential cost management:

- Energy monitoring in building automation systems
- Renewable energy monitoring
- Energy management
- Commercial sub-metering
- Industrial monitoring
- Accurate cost allocation

PB115451



### The solution for

Markets that can benefit from a solution that includes EM4200 series meters:

- Healthcare
- Data centers
- Buildings
- Industry
- Infrastructure

---

### Benefits

#### System integrators' benefit

- Ease of integration
- Ease of setup
- Cost effectiveness

#### Panel builders' benefit

- Ease of installation
- Cost effectiveness
- Aesthetically pleasing
- Simplified ordering

#### End users' benefit

- Ease of use
- Precision metering & sub-billing
- Billing flexibility
- Comprehensive, consistent and superior performance

### Competitive advantages

- High reliability with high system, or meter accuracy.
- Single part to order a metering chain (System Calibrated).
- Supports a large range of Sensor options. Flex can adapt to CTs from 50 to 5000 A, or different Rogowski coil sizes rated for up to 5000 A.
- Modbus and BACnet protocols along with uni-directional and bi-directional feature sets.
- Wide 90 to 480 V AC input range.
- DIN rail or screw-mount options, including mounting bracket for easy installation.
- Seamless integration with EcoStruxure™ Power Management software products.

---

### Conformity of standards

- CAN/CSA-C22.2
- EN 61000-6-2
- EN 61000-6-4 Class A
- EN 61010-1
- EN 61326-1 Class A
- FCC 47 CFR Part 15 Class A
- UL 61010-1

---

### Accuracy standards

#### Flex models

- ANSI C12.20-2015 Class 0.2
- IEC 62053-24 Class 1S  
When used with 1/3 V CT (Meter accuracy)
- IEC 62053-22 Class 0.2S 0.2% When used with Rogowski Coils (Meter accuracy)
- IEC 62053-22 Class 0.5S

#### System calibrated

- ANSI C12.1, 1%
- IEC 62053-22 Class 1S 1%

BASIC MULTI-FUNCTION METERING

# EM4200 series

## Functions and characteristics (cont.)

The EM4200 meter series provides a highly flexible retrofit option ideal when adding metering to an existing building, or to integrate in an OEM solution. Designed to simplify the ordering process, the meter is designed in 2 major options:

**System Calibrated** offers the simplest way to order, deploy and meet requirements. The meter comes with pre-mounted Current Transducers (CT), or Rogowski Coils. A single reference provides a System calibrated accuracy meter with a 100, 200, 400A CT, or 5,000A Rogowski coil.

**Flex** offers the flexibility required when the CT, or Rogowski coil, rating or size needs to further adapt to the site. CTs can range from 50 to 5,000A and Rogowski coils can be different sizes with a 5,000 A rating.

### General features

- Uni and Bi-Directional metering to support to power generation application.
- Data logging.
- Modbus and BACnet serial communication with auto-protocol and baud rate detection.
- Configurable with or without power.
- DIN rail or screw-mount options, including mounting brackets for easy installation.
- Seamless integration in Power Monitoring Operations and Power SCADA Operations.
- Wide input range of 90 to 480 V AC.
- Approvals: UL 61010-1, IEC/EN 61010-1

### System calibrated features

- Factory mounted and calibrated Current Transducers (100, 200 or 400 A), or Rogowski coils (5,000 A, 12" or 18" (304.8 mm or 457.2 mm)). Simplifies ordering and commissioning.
- ANSI version only: Fuse packs factory mounted.
- System Accuracy from 1% to 100% load:
- Real Power and Energy: ANSI C12.1 1%, IEC 62053-22 Class 1S, 1%.
- Reactive Power and Energy: IEC 62053-24 Class 1, 1%

### Flex features

- Supports generic 1/3 V CTs from 50 to 5,000 A. Or 1/3 V 5,000 A Rogowski coils.
- ANSI: Optional fuse packs available.
- Meter Accuracy from 1% to 100% of load (CT mode):
  - Real Power and Energy: ANSI C12.20 0.2%, IEC 62053-22 Class 0.2S, 0.2%.
  - Reactive Power and Energy: IEC 62053-24 Class 1, 1%.



EM4200 Flex Power Meter



EM4200 System  
Calibrated with calibrated Rogowski coils

BASIC MULTI-FUNCTION METERING

# EM4200 series

## Selection guide

Advantage	EM4200 Flex		EM4200 System Calibrated			
	METSEEM4235	METSEEM4236	METSEEM4235Axx	METSEEM4236Axx	METSEEM4235Bxx	METSEEM4236Bxx
<b>General</b>						
Market	IEC	ANSI	IEC	ANSI	IEC	ANSI
Single part to order			Yes	Yes	Yes	Yes
Factory mounted CTs/Rogowski coil			Yes	Yes	Yes	Yes
<b>CT</b>						
Rating	50 to 5000 A user choice	50 to 5000 A user choice	5000 A	5000 A	100, 200 or 400 A	100, 200 or 400 A
Type	1/3 V Solid or Split Core	1/3 V Solid or Split Core			Split Core	Split Core
<b>Rogowski Coil</b>						
Rating	5000 A	5000 A	5000 A	5000 A		
Type						
Size	User choice	User choice	12" or 18"	12" or 18"		
<b>Accuracy</b>						
Meter	0.2% with CTs 0.5% with Rogowski Coil	0.2% with CTs 0.5% with Rogowski Coil				
System			1%	1%	1%	1%
<b>Fuse pack</b>						
	Option sold separately	Option sold separately		Factory mounted		Factory mounted
<b>Communication</b>						
	BACnet MS/TP Modbus RTU over RS485	BACnet MS/TP Modbus RTU over RS485	BACnet MS/TP Modbus RTU over RS485	BACnet MS/TP Modbus RTU over RS485	BACnet MS/TP Modbus RTU over RS485	BACnet MS/TP Modbus RTU over RS485

## EM4200 parts descriptions and advantages

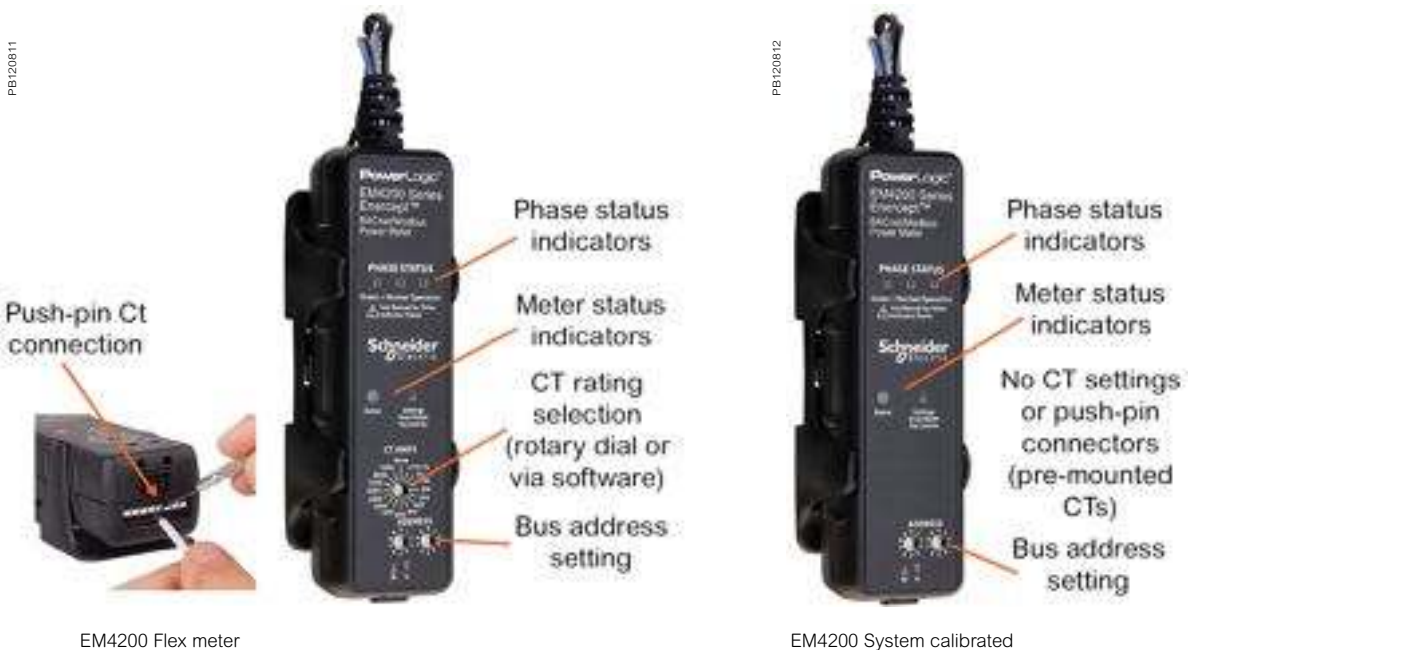

BASIC MULTI-FUNCTION METERING

# EM4200 series

## Functions and characteristics

Electrical characteristics		EM4200 Flex	EM4200 System Calibrated				
Input-voltage characteristics	Inputs	V1, V2, V3, Vn	V1, V2, V3, Vn				
	Measured voltage	90 - 277 V AC L-N UL max 480 V L-L CE max 300 V L-N	90 - 277 V AC L-N UL max 480 V L-L CE max 300 V L-N				
	Frequency range	50/60 Hz	50/60 Hz				
Mechanical characteristics							
Weight		approx. 2.2 lb (1.0 kg)	Between 3.10 lb and 4.85 lb (1.4 and 2.2 Kg) (model dependent)				
Dimensions		1.84 x 1.41 x 6.0 in (46.63 x 35.81 x 152.36 mm)	1.84 x 1.41 x 6.0 in (46.63 x 35.81 x 152.36 mm) (Meter alone), CT/Rogowski size varies with model				
Environmental conditions							
Operating temperature		-30 °C to 70 °C (-22 to 158 °F)	0 to 70 °C (32 to 158 °F)				
Storage temperature		-40 °C to 85 °C (-40 to 185 °F)	with Split Core CTs: -40 to 85 °C (-40 to 185 °F) with Rogowski Coils: -40 to 70 °C (-40 to 158 °F)				
Humidity rating		<95 % RH non-condensing	<95 % RH non-condensing				
Enclosure		Indoor use only - not suitable for wet locations	Indoor use only - not suitable for wet locations				
Altitude		3000 m (10,000 ft)	3000 m (10,000 ft)				
Pollution degree		2	2				
Electromagnetic compatibility							
Compliance							
		CAN/CSA-C22.2 EN 61000-6-2 EN 61000-6-4 Class A EN 61010-1 EN 61326-1 Class A FCC 47 CFR Part 15 Class A UL 61010-1	CAN/CSA-C22.2 EN 61000-6-2 EN 61000-6-4 Class A EN 61010-1 EN 61326-1 Class A FCC 47 CFR Part 15 Class A UL 61010-1				
Accuracy							
		ANSI C12.20-2015 Class 0.2	ANSI C12.20-2015 Class 0.2				
		IEC 62053-24 Class 1S	IEC 62053-24 Class 1S				
		ANSI C12.20 2015 Class 0.2 IEC 62053-24 Class 1S When used with 1/3 V CT (Meter accuracy) IEC 62053-22 Class 0.2S 0.2% When used with Rogowski coils (Meter accuracy) IEC 62053-22 Class 0.5S	ANSI C12.1 1% IEC 62053-21 Class 1S 1% IEC 62053-24 Class 1 1%				
Commercial Reference Numbers							
Market	Commercial ref. no.	Rating	CTR type	CT size	Fuse pack	CT lead length	System calibrated
IEC	METSEEM4235	User choice					
IEC	METSEEM4235A12	Up to 5000 A (3 Coils supplied)	Rogowski	12" (304.8 mm)		6 ft (1828.8 mm)	Yes
IEC	METSEEM4235A18	Up to 5000 A (3 Coils supplied)	Rogowski	18" (457.2 mm)		6 ft (1828.8 mm)	Yes
IEC	METSEEM4235B101	100 A (3 CTs supplied)	Split core			6 ft (1828.8 mm)	Yes
IEC	METSEEM4235B201	200 A (3 CTs supplied)	Split core			6 ft (1828.8 mm)	Yes
IEC	METSEEM4235B401	400 A (3 CTs supplied)	Split core			6 ft (1828.8 mm)	Yes
ANSI	METSEEM4236	User choice			Option		
ANSI	METSEEM4236A12	Up to 5000 A (3 Coils supplied)	Rogowski	12" (304.8 mm)	Yes	6 ft (1828.8 mm)	Yes
ANSI	METSEEM4236A18	Up to 5000 A (3 Coils supplied)	Rogowski	18" (457.2 mm)	Yes	6 ft (1828.8 mm)	Yes
ANSI	METSEEM4236B101	100 A (3 CTs supplied)	Split core		Yes	6 ft (1828.8 mm)	Yes
ANSI	METSEEM4236B201	200 A (3 CTs supplied)	Split core		Yes	6 ft (1828.8 mm)	Yes
ANSI	METSEEM4236B401	400 A (3 CTs supplied)	Split core		Yes	6 ft (1828.8 mm)	Yes

BASIC MULTI-FUNCTION METERING

# EM4200 series

## Dimensions

### EM4200 dimensions

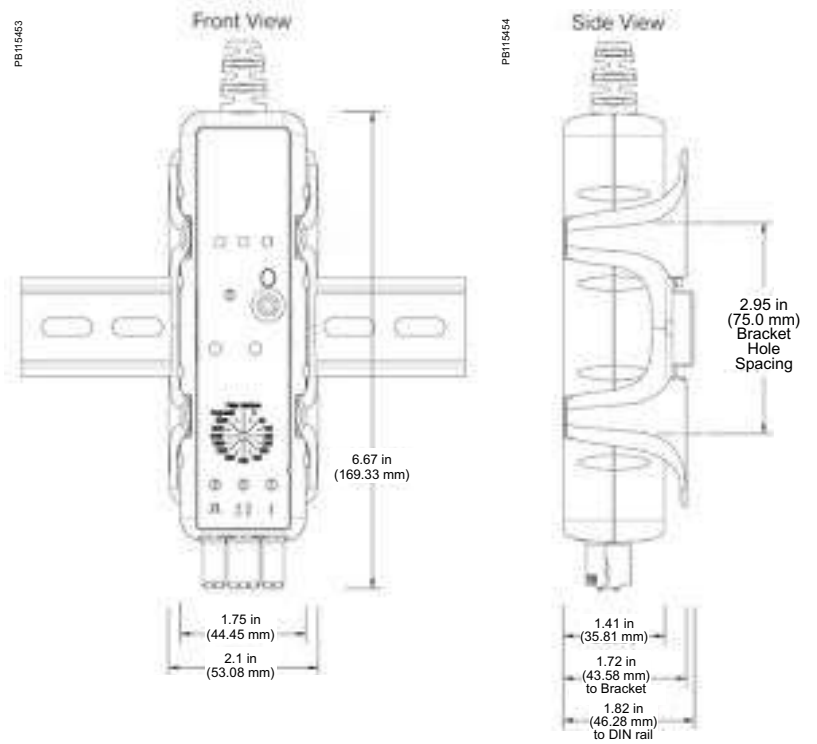
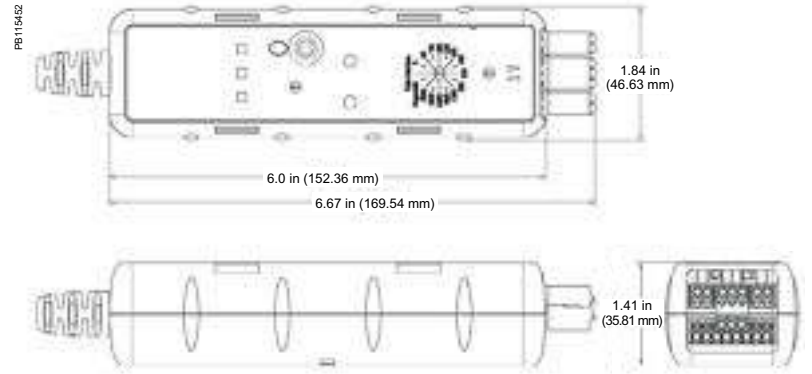

# Intermediate metering

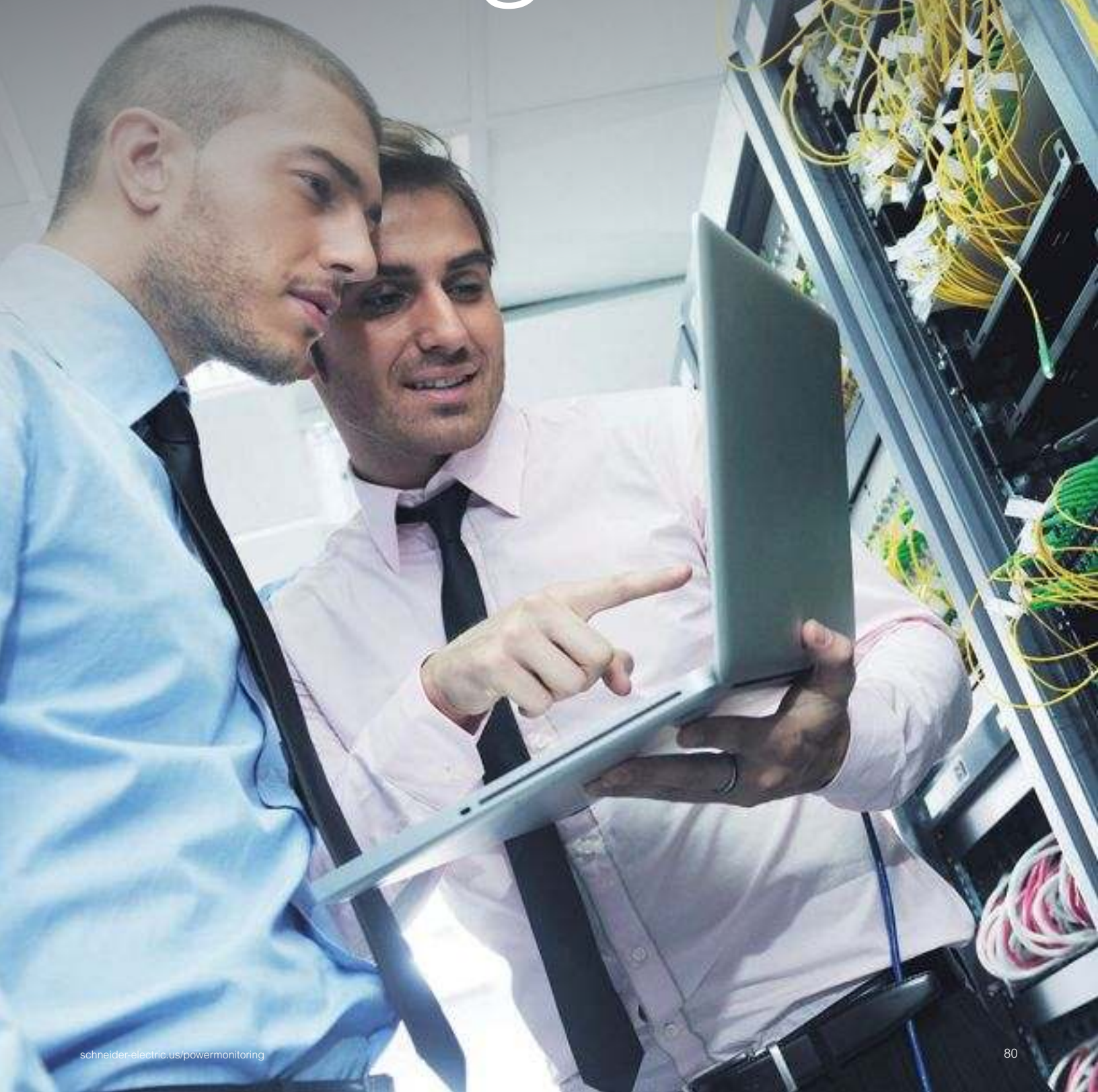

# Applications

Intermediate meters are designed for low- to high-voltage network management applications for your critical loads, feeders, and LV incomers.

These meters seek to improve the availability and reliability of your electrical system in industrial facilities, data centers, commercial buildings, utilities networks, or critical power environments. They are fully capable of supporting billing and cost allocation applications.

# Product overview

## Intermediate metering

Introducing the PowerLogic PM8000 series meters — a range of power and energy meters designed for network monitoring applications like tracking real-time power conditions, monitoring network and equipment status, load trending, harmonics measurement, and alarm and event logging and reporting. Ensure the reliability and efficiency of your power-critical facility.

- PowerLogic PM8000

INTERMEDIATE METERING



INTERMEDIATE METERING

## PM8000 series

The PowerLogic PM8000 series meters are compact, cost-effective multifunction power meters that will help you ensure reliability and efficiency of your power-critical facility.

Reveal and understand complex power quality conditions. Measure, understand, and act on insightful data gathered from your entire power system. Designed for key metering points throughout your energy infrastructure, the PowerLogic PM8000 series meter has the versatility to perform nearly any job you need a meter to do, wherever you need it.

### Applications:

- Ideal for low- to high-voltage applications in industrial facilities, commercial buildings, utility networks, or critical power environments



## INTERMEDIATE METERING

### The solution for

Markets that can benefit from a solution that includes PowerLogic PM8000 series meters:

- Healthcare
- Data centers
- Buildings
- Industry
- Infrastructure
- Utility

### Benefits

- Makes understanding power quality simple to help operations personnel avoid downtime and ensure increased productivity and equipment life
- Makes energy and power quality immediately relevant and actionable to support your operational and sustainability goals
- Maximize profits by providing the highest output possible with the least amount of risk to availability
- Optimize availability and reliability of electrical systems and equipment

### Competitive advantages

- ION technology
- Color screen
- Multiple communication options

### Conformity of standards

- IEC 61557-12
- IEC 62586
- IEC 62053-22
- IEC 62053-24
- EN50470-1
- EN50470-3
- IEC 61000-4-30
- EN50160
- IEC 62053-11
- IEC 61000-4-2
- IEC 61000-4-3
- IEC 61000-4-4
- IEC 61000-4-5
- IEC 61000-4-6
- IEC 61000-4-8
- IEC 61010

INTERMEDIATE METERING



PowerLogic PM8000 series meter



PowerLogic PM8000 series meter – rear view



PowerLogic PM8000 DIN rail mounted meter

Main characteristics

- Precision metering
  - IEC 61557-12 PMD Sx K70 3000m 0.2 (performance measuring and monitoring functions)
  - Class 0.2S accuracy IEC 62053-22, ANSI C12.20 Class 0.2 (active energy)
  - Industry-leading Class 0.5S\* accuracy for reactive energy (IEC 62053-24)
  - Cycle-by-cycle RMS measurements updated every half cycle
  - Full multi-utility WAGES metering support
  - Net metering
  - Anti-tamper protection seals
- PQ compliance reporting and basic PQ analysis:
  - Monitors and logs parameters in support of international PQ standards
    - IEC 61000-4-30 Class S
    - IEC 62586 PQI-S
    - EN 50160
  - Generates onboard PQ compliance reports accessible via onboard web pages
    - Basic event summary and pass/fail reports, such as EN 50160 for power frequency, supply voltage magnitude, supply voltage dips, short and long interruptions, temporary over voltages, voltage unbalance, and harmonic voltage
    - ITIC (CBEMA) and SEMI curves, with alarm categorization to support further analysis
    - NEMA motor derating curve
    - Basic meter provides EN 50160 but can be configured to provide IEEE 519
  - Harmonic analysis
    - THD on voltage and current, per phase, min/max, custom alarming
    - Individual harmonic magnitudes and angles on voltage and current, up to the 63rd harmonic
  - High-resolution waveform capture: triggered manually or by alarm, captured waveforms available directly from the meter via FTP in a COMTRADE format
  - Disturbance detection and capture: sag and swell on any current and voltage channel, alarm on disturbance event, waveform capture with pre-event information
  - Patented disturbance direction detection: provides indication of the captured disturbance occurring upstream or downstream of the meter; timestamped results provided in the event log with degree of certainty of disturbance direction
- When used with EcoStruxure Power Monitoring Expert software, provides detailed PQ reporting across entire network
  - EN50160:2010, and IEEE 519:2014
  - IEC 61000-4-30 report
  - PQ compliance summary
  - ISO 50001
  - Display of waveforms and PQ data from all connected meters
  - Onboard data and event logging
  - 512MB of standard non-volatile memory; 10 MB of standard non-volatile memory dedicated to capture billing data, events, and waveforms

INTERMEDIATE METERING



PowerLogic remote display



PowerLogic I/O module



PowerLogic PM8000 series meter with remote display

- No data gaps due to network outages or server downtime
- Min/max log for standard values
- 50 user-definable data logs, recording up to 16 parameters on a cycle-by-cycle or other user-definable interval
- Continuous logging or 'snapshot' triggered by setpoint and stopped after defined duration
- Trend energy, demand, and other measured parameters
- Forecasting via web pages: average, minimum, and maximum for the next four hours and next four days
- Time-of-use in conjunction with EcoStruxure software
- Event log: alarm conditions, metering configuration changes, and power outages, timestamped to one millisecond
- Alarming and control
  - 50+ definable alarms to log critical event data, trigger waveform recording, or perform control function
  - Trigger on any condition, with cycle-by-cycle and one-second response time
  - Combine alarms using Boolean logic and to create alarm levels
  - Alarm notification via email and message
  - In conjunction with EcoStruxure Power Monitoring Expert, software alarms and alarm frequency are categorized and trended for easy evaluation of worsening or improving conditions
- Excellent quality: ISO 9001 and ISO 14000 certified manufacturing

Usability

- Easy installation and setup
  - Panel and DIN rail mounting options, remote display option
  - Pluggable connectors
  - Free setup application simplifies meter configuration
- Front panel
  - Easy to read color graphic display
  - Simple, intuitive menu navigation with multi-language (8) support
- Flexible remote communications
  - Multiple simultaneously operating communication ports and protocols allow interfacing with other automation systems; (e.g., waveforms, alarms, billing data, etc.) can be uploaded for viewing and analysis while other systems access real-time information
  - Supports Modbus, ION, DNP3, and IEC 61850
  - Dual port Ethernet: 10/100BASE-TX; daisy-chaining capability removes need for additional switches
  - Create redundant network loop using rapid spanning tree protocol (RSTP) and managed Ethernet switches
  - Customize TCP/IP port numbers allow individual ports to be enabled and disabled
  - RS-485 two-wire connection, up to 115200 baud, Modbus RTU, and ION protocols; DNP3 is also supported via RS-485
  - Ethernet to serial gateway with Modbus Master functionality, connecting to 31 downstream serial Modbus devices; also supports Modbus mastering over TCP/IP (Ethernet) network
  - Full-function web server with factory and customizable pages to access real-time and PQ-compliance data
  - Push historical data via email
  - Advanced security: up to 16 configurable user accounts

INTERMEDIATE METERING



PowerLogic PM8000 series meter with I/O modules

- Time synchronization via
  - GPS clock (RS485) or IRIG-B (digital input) to +/- 1 millisecond; also supports Network Time Protocol (NTP/SNTP), Precision time protocol (PTP), and timeset function from EcoStruxure software server

Adaptability

- ION™ frameworks allow customizable, scalable applications, object-oriented programming, compartmentalizes functions, and increases flexibility and adaptability
- Applications include access and aggregate data from Modbus devices on serial port or across the network (Modbus TCP/IP), logging and/or processing data by totaling, unit conversion or other calculations, applying complex logic for alarming or control operations, and data visualization via web pages

Standard meter I/O

- Three digital status/counter inputs
- One KY (Form A) energy pulse output for interfacing with other systems

Modular I/O options

- Optional expansion modules
- Up to two modules per panel mounted meter
- Up to four module per DIN rail mounted meter

Option modules include

- Digital module
  - Six digital status/counter inputs
  - Two form C relay outputs, 250V, 8A
- Analog module
  - Four analog inputs (4-20mA, 0-1mA, 0-20mA; 0-30V)
  - Two analog outputs (4-20mA, 0-1mA, 0-20mA; 0-10V) for interfacing with building management sensors and systems

Commercial reference numbers	
Meter description	Commercial ref. no.
DIN96 panel mount meter	METSEPM8240
DIN rail mount meter	METSEPM8243
DIN rail mount meter with remote display	METSEPM8244
Accessories description	Commercial ref. no.
Remote display, 3 M cable, mounting hardware for 1.18 in (30 mm) hole (nut and centering pin), mounting hardware for DIN96 cutout 3.62 x 3.62 in (92 x 92 mm) adapter plate	METSEPM89RD96
Terminal covers for utility sealing	METSEPM8000SK
Adapters for mounting meter and remote display back-to-back and ANSI 4.01 in (102 mm), 11.81 in (300 mm) Ethernet cable	METSEPM8000SK
Display cable, 1 meter	METSECAB1
Display cable, 3 meters	METSECAB3
Display cable, 10 meters	METSECAB10
Digital I/O module (6 digital inputs and 2 relay outputs)	METSEPM89M2600
Analog I/O module (4 analog inputs and 2 analog outputs)	METSEPM89M0024
PM8000 hardware kit	METSEPM8HWK
PM8000 remote display hardware kit	METSEPM8RDHWK

INTERMEDIATE METERING

PB113696



PowerLogic™ PM8000 bottom view DIN mounting

Feature guide

PM8000

General		
Use on LV and MV systems		■
Current accuracy (5A nominal)		0.1 % reading
Voltage accuracy (57 V LN/100 V LL to 400 V LN/690 V LL)		0.1 % reading
Active energy accuracy		0.2 %
Number of samples per cycle or sample frequency		256
Instantaneous RMS values		
Current, voltage, frequency		■
Active, reactive, apparent power	Total and per phase	■
Power factor	Total and per phase	■
Current measurement range (autoranging)		0.05 - 10A
Energy values		
Active, reactive, apparent energy		■
Settable accumulation modes		■
Demand values		
Current	Present and max values	■
Active, reactive, apparent power	Present and max values	■
Predicted active, reactive, apparent power		■
Synchronization of the measurement window		■
Setting of calculation mode	Block, sliding	■
Power quality measurements		
Harmonic distortion	Current and voltage	■
Individual harmonics	Via front panel and web page	63
	Via EcoStruxure software	127
Waveform capture		■
Detection of voltage swells and sags		■
Fast acquisition	1/2 cycle data	■
EN 50160 compliance checking		■
Customizable data outputs (using logic and math functions)		■
Data recording		
Min/max of instantaneous values		■
Data logs		■
Event logs		■
Trending/forecasting		■
SER (sequence of event recording)		■
Timestamping		■
GPS synchronization (+/- 1 ms)		■
Memory (in MB)		512
Display and I/O		
Front panel display		■
Wiring self-test		■
Pulse output		1
Digital or analog inputs (max)		27 digital, 16 analog
Digital or analog outputs (max, including pulse output)		1 digital, 8 relay, 8 analog
Communication		
RS 485 port		1
Ethernet port		2
Serial port (Modbus, ION, DNP3)		■
Ethernet port (Modbus/TCP, ION TCP, DNP3 TCP, IEC 61850 <sup>(2)</sup> )		■
Ethernet gateway		■
Alarm notification via email		■
HTTPS web server		■
SNMP with custom MIB and traps for alarms		■
SMTP email		■
NTP and PTP time synchronization		■
FTP file transfer		■

INTERMEDIATE METERING

# PM8000 series

## Functions and characteristics (cont.)

### Technical specifications

Electrical characteristics		
Type of measurement		True RMS to 256 samples per cycle
Measurement accuracy	Current and voltage	Class 0.2 as per IEC 61557-12
	Active power	Class 0.2 as per IEC 61557-12
	Power factor	Class 0.5 as per IEC 61557-12
	Frequency	Class 0.2 as per IEC 61557-12
	Active energy	Class 0.2S IEC 62053-22 (In=5A) Class 0.2 IEC 61557-12, ANSI C12.20 Class 0.2
	Reactive energy	Class 0.5S IEC 62053-24*
	MID directive	EN50470-1, EN50470-1, annex B and annex D (optional model)
Data update rate		1/2 cycle or 1 second
Input-voltage characteristics	Specified accuracy voltage	57 VLN/100 VLL to 400 VLN/690 VLL
	Impedance	5 MΩ per phase
	Specified accuracy frequency — frequency	42 to 69Hz (50/60Hz nominal)
	Limit range of operation — frequency	20 to 450Hz
Input-current characteristics	Rated nominal current	1A (0.5S), 5A (0.2S), 10A (0.2 ANSI)
	Specified accuracy current range	Starting current: 5mA Accurate range: 50mA - 10A
	Permissible overload	200 A RMS for 0.5s, non-recurring
	Impedance	0.0003 Ω per phase
	Burden	0.024 VA at 10A
Power supply	AC	90-415 V AC ±10% (50/60Hz ± 10%)
	DC	120-300 V DC ±10%
	Ride-through time	100 ms (6 cycles at 60 Hz) min., any condition 200 ms (12 cycles at 60 Hz) typ., 120 V AC 500 ms (30 cycles at 60 Hz) typ., 415 V AC
	Burden	Meter only: 18 VA max at 415V AC, 6W at 300V DC Fully optioned meter: 36 VA max at 415V AC, 17W at 300V DC
Input/outputs	Meter base only	3 Form A digital inputs (30V AC/60 V DC) 1 Form A (KY) solid state digital output (30V AC/60 V DC, 75mA)
	Optional	Digital — 6 Form A digital inputs (30V AC/60V DC) wetted + 2 Form C relay outputs (250V AC, 8A) Analog — 4 Analog inputs (4-20mA, 0-30V) + 2 analog outputs (4-20mA, 0-10V DC)

Mechanical characteristics		
Weight		Integrated Display Model 1.28 lb (0.581 kg) DIN rail mounted Model 1.16 lb (0.528 kg) IO modules 0.31 lb (0.410 kg) Remote display 0.66 lb (0.300 kg)
IP degree of protection		IP 54, UL type 12: panel mount and remote display, front IP 30: panel mount rear, DIN rail mount, I/O modules
Dimensions	Panel mount model	3.78 x 3.78 x 3.05 in (96 x 96 x 77.5 mm)
	DIN model	3.56 x 3.56 x 3.58 in (90.5 x 90.5 x 90.8 mm)
	Remote display	3.78 x 3.78 x 1.06 in (96 x 96 x 27 mm)
	IO modules	3.56 x 3.56 x 0.87 in (90.5 x 90.5 x 22 mm)

INTERMEDIATE METERING

# PM8000 series

## Functions and characteristics (cont.)

Environmental conditions	
Operating temperature	-25 °C to +70 °C
Remote display unit	-25 °C to +60 °C
Storage temperature	-40 °C to +85 °C
Humidity rating	5% to 95% non-condensing
Installation category	III
Operating altitude (maximum)	3000 meters above sea level
Electromagnetic compatibility	
Product standards	IEC 62052-11 and IEC 61326-1
Immunity to electrostatic discharge	IEC 61000-4-2
Immunity to radiated fields	IEC 61000-4-3
Immunity to fast transients	IEC 61000-4-4
Immunity to surges	IEC 61000-4-5
Immunity to conducted disturbances	IEC 61000-4-6
Immunity to power frequency magnetic fields	IEC 61000-4-8
Immunity to conducted disturbances, 2-150kHz	CLC/TR 50579
Immunity to voltage dips and interruptions	IEC 61000-4-11
Immunity to ring waves	IEC 61000-4-12
Conducted and radiated emissions	EN 55022, EN 55011, FCC part 15, ICES-003
Surge withstand capability (SWC)	IEEE C37.90.1
Safety	
Safety construction	IEC/EN 61010-1 ed.3, CAT III, 400 VLN / 690 V LL UL 61010-1 ed.3 and CSA-C22.2 No. 61010-1 ed.3, CAT III, 347 V LN / 600 V LL IEC/EN 62052-11, protective class II
Communication <sup>(1)</sup>	
Ethernet to serial line gateway	Communicates directly with up to 32 unit load ION slave devices
Web server	Customizable pages, new page creation capabilities, HTML/XML compatible
Serial port RS 485	Baud rates of 2400 to 115200, pluggable screw terminal connector
Ethernet port(s)	2x 10/100BASE-TX, RJ45 connector (UTP)
Protocol	Modbus, ION, DNP3, IEC 61850, HTTPS, FTP, SNMP, SMTP, DPWS, RSTP, NTP, SNTP, GPS protocols
Firmware characteristics	
High-speed data recording	Down to 1/2 cycle interval burst recording, stores detailed characteristics of disturbances or outages; trigger recording by a user-defined setpoint or from external equipment
Harmonic distortion	Up to 63rd harmonic (127th via EcoStruxure software) for all voltage and current inputs
Sag and swell detection	Analyze severity/potential impact of sags and swells: magnitude and duration data suitable for plotting on voltage tolerance curves per phase triggers for waveform recording and control
Disturbance direction detection	Determine the location of a disturbance more quickly and accurately by determining the direction of the disturbance relative to the meter; analysis results are captured in the event log, along with a timestamp and confidence level indicating level of certainty
Instantaneous	High accuracy of standard speed (1s) and high-speed (1/2 cycle) measurements, including true RMS per phase and total for voltage current, active power (kW), reactive power (kvar), apparent power (kVA), power factor, frequency, voltage and current unbalance, and phase reversal

# PM8000 series

## Functions and characteristics (cont.)

Firmware characteristics (cont.)	
Load profiling	Channel assignments (800 channels via 50 data recorders) configurable for any measurable parameter, including historical trend recording of energy, demand, voltage, current, power quality, or any measured parameter; trigger recorders based on time interval, calendar schedule, and alarm or event condition, or settings can be configured manually.
Trend curves	Historical trends and future forecasts to better manage demand, circuit loading, and other parameters; provides average, minimum, maximum, and standard deviation every hour for the last 24 hours, every day for last month, every week for last eight weeks, and every month for last 12 months
Waveform captures	Ability to record from 210 cycles at 256 samples per cycle to over 2880 cycles at 16 samples per cycle with user selectable sampling rate as well as pre- and post-trigger lengths
Alarms	Threshold alarms: adjustable pickup and dropout setpoints and time delays, numerous activation levels possible for a given type of alarm, user-defined or automatic alarm threshold settings, user-defined priority levels (optional automatic alarm setting)
Advanced security	Up to 16 users with unique access rights; users can perform resets, time sync, or meter configurations based on user privileges
Memory	512MB (10MB for programming and interval logging)
Firmware update	Update via the communication ports
Display characteristics	
Integrated or remote display	320 x 240 (1/4 VGA) Color LCD, configurable screens, five buttons and two LED indicators (alarm and meter status)
Languages	English, French, Spanish, Russian, Portugese, German, Italian, and Chinese
Notations	IEC, IEEE
The HMI menu includes	
Alarms	Active alarms, historic alarms
Basic reading	Voltage, current, frequency, power summary
Power	Power summary, demand, power factor
Energy	Energy total, delivered, received
Events	Timestamped verbose event log
Power quality	EN 50160, harmonics, phasor diagrams
Inputs/outputs	Digital inputs, digital outputs, analog inputs, analog outputs
Nameplate	Model, serial, and FW version
Custom screens	Build your own metrics
Setup menu	Meter setup, communications setup, display setup, date/time/clock setup, alarm setup, language setup, time-of-use setup, resets, password setup

INTERMEDIATE METERING

# PM8000 series

## PM8240 and PM82401 dimensions

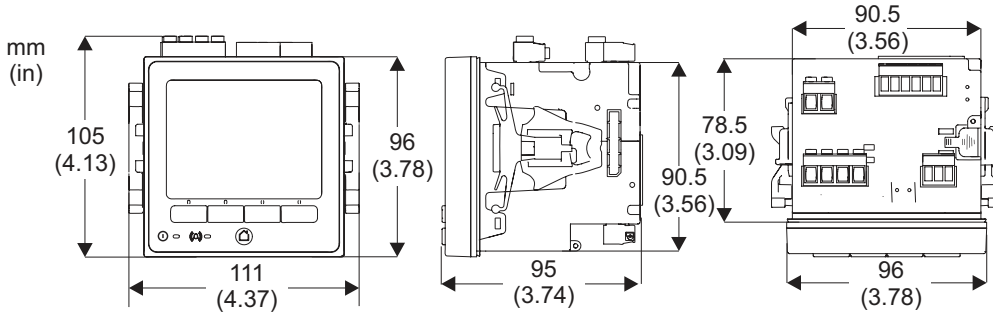

## PM8243 dimensions

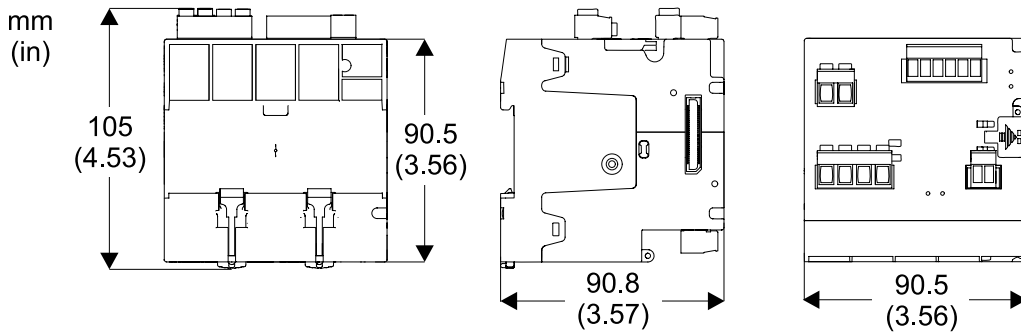

## PM89RD96 dimensions

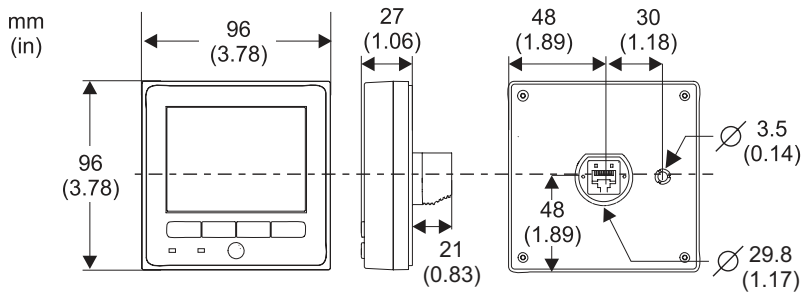

## PM89M2600 and PM89M0024 dimensions

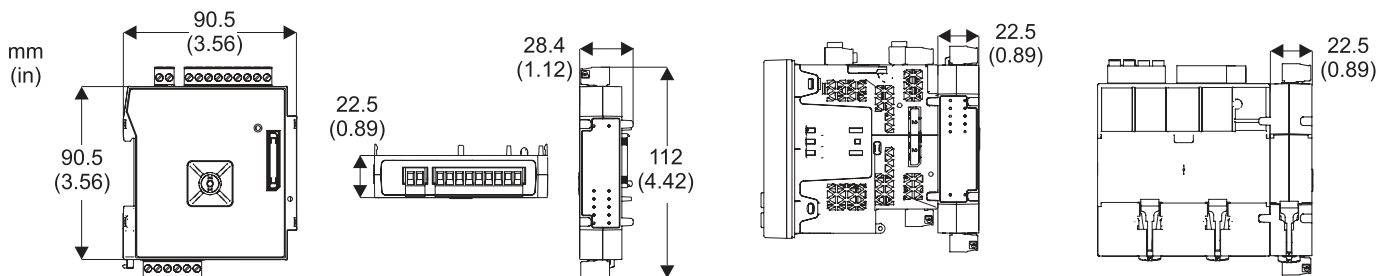

# Advanced metering



# Applications

Advanced high-performance meters are designed for mains or critical loads on MV/LV networks. They provide analysis of efficiency, losses and capacity, bill verification, power quality compliance monitoring, problem notification and diagnosis, and control of loads, etc.

# Product overview

## Advanced metering

Power quality meters are classified as advanced meters designed to monitor service entrances and critical network locations to maximize power availability and reliability by providing a comprehensive system load profile, power quality, and root cause analyses.

- PowerLogic ION7550/7650
- PowerLogic CM4000T
- PowerLogic ION9000

ADVANCED METERING



ION7550/7650 series (VFD)



CM4000 + vacuum fluorescent display (VFD)

## ADVANCED METERING

# ION7550/7650 series

Ideal for both energy suppliers and consumers, and loaded with advanced functionality for monitoring key distribution points and sensitive loads, the PowerLogic ION7650/7550 power and energy meter offers an unmatched feature set, including advanced power quality analysis coupled with revenue accuracy, multiple communications options, web compatibility, and control capabilities.

## Applications

- Analysis of efficiency, losses, and capacity
- Bill verification, cost allocation, and submetering
- Power quality compliance monitoring
- Problem notification and diagnosis
- Demand or power factor management
- Control of loads, generators, or other equipment



### The solution for

Markets that can benefit from a solution that includes PowerLogic ION7550/7650 series meters

- Critical buildings
- Industry
- Data centers and networks
- Infrastructure (e.g., airports, road tunnels, telecom)

---

### Competitive advantages

ION technology

- Customize metering or analysis functions at your work station without hard wiring
- Just link drag-and-drop icons or select default settings

Flexibility of connectivity

- Be integrated with Power Monitoring Experts or share data with SCADA system via multiple communication channels and protocols

---

### Benefits

The PowerLogic ION7650/ION7550 meters help you

- Reduce energy and operations costs
- Improve power quality, reliability, and uptime
- Optimize equipment use for optimal management of your electrical installation and for greater productivity

### Conformity of standards

- |                   |                      |
|-------------------|----------------------|
| • IEC 62053-22    | • IEEE 1453*         |
| • IEEE 519        | • IEC 61000-4-2      |
| • IEEE 1159       | • IEC 61000-4-3      |
| • CNEMA/ITIC      | • IEC 61000-4-4      |
| • IEC 61000-4-30* | • IEC 61000-4-5      |
| • EN 50160*       | • CISPR 22           |
| • IEC 61000-4-7*  | • IEC 61010-1        |
| • IEC 61000-4-15* | <i>*ION7650 only</i> |

ADVANCED METERING

Main characteristics

- Anticipate, diagnose, and verify to increase efficiency
  - Reveal energy inefficiencies or waste and optimize equipment operation to increase efficiency; isolate reliability risks, diagnose power-related equipment issues, and verify reliable operation
- Summarize power quality, set targets, and measure and verify results
  - Consolidate all the power quality characteristics into a single trendable index; benchmark power quality and reliability and compare against standards, or compare facilities or processes
- Easy-to-use, multi-lingual, IEC/IEEE configurable display
  - Bright LCD display with adjustable contrast; screen-based menu system to configure meter settings including IEC or IEEE notations; multilingual support for English, French, Spanish, and Russian; 12/24-hour clock support in multiple formats
- Modbus Master functionality
  - Read information from downstream Modbus devices and view it via the front panel, or store in memory until you upload to the system level.
- IEC 61850 protocol
- Increase interoperability and decrease engineering time using standard protocol
- Gateway functionality
  - Access through the meter’s Ethernet port (EtherGate) or telephone network (ModemGate) to Modbus communicating devices connected to meter serial ports
  - Detect and capture transients as short as 20µs at 50 Hz (17µs at 60 Hz)
  - Identify problems due to short disturbances, e.g., switching of capacitors, etc.
- Power quality compliance monitoring
  - Monitor compliance with international quality-of-supply standards (IEC 61000-4-30 Class A ed. 2(1), EN50160(1), IEC 61000-4-7(1), IEC 61000-4-15(1), IEEE 519, IEEE 1159, and CBEMA/ITIC); evaluate flicker based on IEC 61000-4-15(1) and IEEE 1453(1)
- Detect waveshape changes
  - Detection of phase switching phenomena (e.g., during the transfer of a high-speed static switch) not detected by classical threshold-based alarms
- Record ultra-fast electrical parameters every 100 ms or every cycle
  - Preventive maintenance: acquisition of a motor startup curve, etc.
- Trend curves and short-term forecasting
  - Rapid trending and forecasting of upcoming values for better decision making
- Disturbance direction detection
  - Determine disturbance location and direction relative to the meter; results captured in the event log, along with a timestamp and certainty level
- Alarm setpoint learning
  - The meter analyzes the circuit and recommends alarm setpoints to minimize nuisance or missed alarms
- Alarm notification via email
  - High-priority alarms can be sent directly to the user’s PC; instant notification of power quality events by email<sup>1)</sup>; ON7650 only

Commercial reference numbers	
Description	Commercial ref. no.
ION7550	M7550
ION7650	M7650
Remote display	M765RD
Remote display with power supply	M765RDPS

ADVANCED METERING

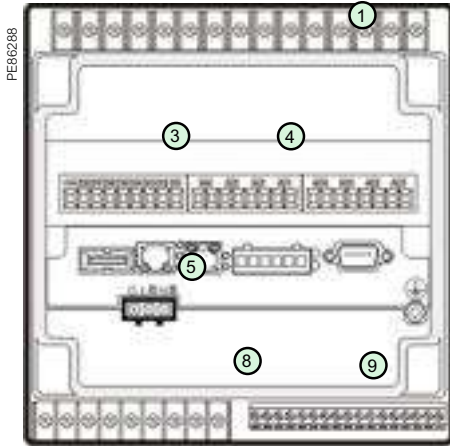

PowerLogic™ ION7550/ION7650 rear view

- 1 Current/voltage inputs
- 2 Digital inputs
- 3 Analog inputs
- 4 Analog outputs
- 5 Communications card
- 6 Power supply
- 7 Form C digital outputs
- 8 Digital inputs
- 9 Form A digital outputs

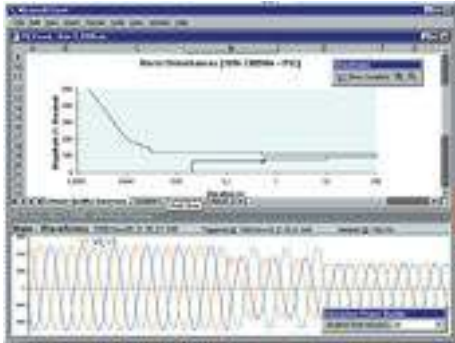

Disturbance waveform capture and power quality report

Selection guide

General		ION7550	ION7650
Use on LV and HV systems		■	■
Current accuracy (1A to 5A)		0.1 % reading	0.1 % reading
Voltage accuracy (57V to 288V)		0.1 % reading	0.1 % reading
Energy accuracy		0.2 %	0.2 %
Number of samples per cycle or sample frequency		256	1024
Instantaneous RMS values			
Current, voltage, frequency		■	■
Active, reactive, apparent power	Total and per phase	■	■
Power factor	Total and per phase	■	■
Current measurement range (autoranging)		0.0 $\pm$ 5 - $\sqrt{2}$ †	0.0 $\pm$ 5 - $\sqrt{2}$ †
Energy values			
Active, reactive, apparent energy		■	■
Settable accumulation modes		■	■
Demand values			
Current	Present and max values	■	■
Active, reactive, apparent power	Present and max values	■	■
Predicted active, reactive, apparent power		■	■
Synchronization of the measurement window		■	■
Setting of calculation mode	Block, sliding	■	■
Power quality measurements			
Harmonic distortion	current and voltage	■	■
Individual harmonics	via front panel	63	63
	via ION Enterprise	127	511
Waveform capture		■	■
Detection of voltage swells and sags		■	■
Detection and capture of transients		-	20 $\mu$ s <sup>(1)</sup>
Flicker		-	■
Fast acquisition of 100 ms or 20 ms data		■	■
EN50160 compliance checking		-	■
Programmable (logic and math functions)		■	■
Data recording			
Min/max of instantaneous values		■	■
Data logs		■	■
Event logs		■	■
Trending/forecasting		■	■
SER (sequence of event recording)		■	■
Timestamping		■	■
GPS synchronization (1 ms)		■	■
Memory (in MB)		10	10
Display and I/O			
Front-panel display		■	■
Wiring self-test		■	■
Pulse output		1	1
Digital or analog inputs (max)		20	20
Digital or analog outputs (max, including pulse output)		12	12
Communication			
RS 485 port		1	1
RS 485/RS 232 port		1	1
Optical port		1	1
Modbus protocol		■	■
IEC 61850 protocol		■	■
Ethernet port (Modbus/TCP/IP protocol, IEC 61850(2))		1	1
Ethernet gateway (EtherGate)		1	1
Alarms (optional automatic alarm setting)		■	■
Alarm notification via email		■	■
HTML web page server (WebMeter)		■	■
Internal modem		1	1
Modem gateway (ModemGate)		■	■
DNP 3.0 through serial, modem, and I/R ports		■	■

(1) For 50 Hz line frequency; 17 $\mu$ s for 60 Hz line frequency.

# ION7550/7650 series

## Technical specifications

Electrical characteristics		
Type of measurement		True RMS to 1024 samples per cycle (ION7650)
Measurement accuracy	Current and voltage	±0.01% of reading + ±0.025% of full scale
	Power	±0.075% of reading + ±0.025% of full scale
	Frequency	±0.005Hz
	Power factor	±0.002 from 0.5 leading to 0.5 lagging
	Energy	IEC62053-22 0,2S, 1A and 5A
Data update rate		1/2 cycle or 1 second
Input-voltage characteristics	Measurement range	Autoranging 57 V through 347 V LN/600 V LL
	Impedance	5 MΩ/phase (phase - Vref)
	Frequency measurement range	42 to 69Hz
Input-current characteristics	Rated nominal current	1A, 2A, 5A, 10A
	Measurement range	0.005 - 20 A autoranging (standard range) 0.001 - 10 A autoranging (optional range)
	Permissible overload	500 A RMS for 1 s, non-recurring (5A) 50 A RMS for 1s, non-recurring (1A)
	Impedance	0.002 Ω per phase (5A) 0.015 Ω per phase (1A)
Power supply	Burden	0.05 VA per phase (5 A) 0.015 VA per phase (1 A)
	AC	85-240 V AC ±10% (47-63 Hz)
	DC	110-300 V DC ±10%
	DC low voltage (optional)	20-60 V DC ±10%
	Ride-through time	100 ms (6 cycles at 60 Hz) min
Input/outputs <sup>(1)</sup>	Standard	8 digital inputs (120 V DC) 3 relay outputs (250 V AC/30 V DC) 4 digital outputs (solid state)
	Optional	8 additional digital inputs 4 analog outputs, and/or 4 analog inputs
Mechanical characteristics		
Weight		4.19 lb (1.9 kg)
IP degree of protection (IEC 60529)		Integrated display, front: IP 50; back: IP 30 Transducer unit (no display): IP 30
Dimensions	Standard model	7.56 in x 7.56 x 5.91 in (192 x 192 x 150 mm)
	TRAN model	9.27 x 8.52 x 5.24 in (235.5 x 216.3 x 133.1 mm)
Environmental conditions		
Operating temperature	Standard power supply	-20 to +70 °C
	Low-voltage DC supply	-20 to +50 °C
	Display operating range	-20 to +60 °C
Storage temperature	Display, TRAN	-40 to +85 °C
Humidity rating		5 to 95% non-condensing
Installation category		III (2000m above sea level)
Dielectric withstand		As per EN 61010-1, IEC 62051-22A <sup>(2)</sup>
Electromagnetic compatibility		
Electrostatic discharge		IEC 61000-4-2
Immunity to radiated fields		IEC 61000-4-3
Immunity to fast transients		IEC 61000-4-4
Immunity to surges		IEC 61000-4-5
Conducted and radiated emissions		CISPR 22
Safety		
Europe		IEC 61010-1
Communication		
RS 232/485 port <sup>(1)</sup>		Up to 115,200 bauds (57,600 bauds for RS 485), ION, DNP 3.0, Modbus, GPS, EtherGate, ModemGate, Modbus Master
RS 485 port <sup>(1)</sup>		Up to 57,600 bauds, ION, DNP 3.0, Modbus, GPS, EtherGate, ModemGate, Modbus Master
Infrared port <sup>(1)</sup>		ANSI type 2, up to 19,200 bauds, ION, Modbus, DNP 3.0
Ethernet port		10BASE-T/100BASE-TX, RJ45 connector, 100 m link
Fiber optic Ethernet link		100BASE FX, SC duplex connector, 1300 nm, FO multimode with gradient index 62.5/125 μm or 50/125 μm, 2000 m link

(1) Consult the ION7550/ION7650 Installation Guide for complete specifications. (2) IEC 62051-22B with serial ports only.

# ION7550/7650 series (cont.)



PE86004

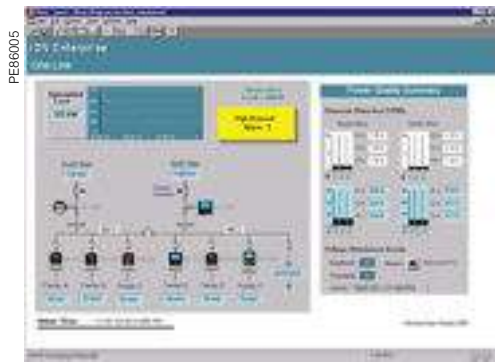

PE86005

Example showing instantaneous values and alarm

Communication (cont.)	
Protocol	ION, Modbus, TCP/IP, DNP 3.0, Telnet, IEC 61850 <sup>(2)</sup>
EtherGate	Communicates directly with up to 62 slave devices via available serial ports
ModemGate	Communicates directly with up to 31 slave devices
Ethernet port	10BASE-T/100BASE-TX, RJ45 connector, 100 m link
WebMeter	5 customizable pages, new page creation capabilities, HTML/XML compatible
Firmware characteristics	
High-speed data recording	Down to 5ms interval burst recording, stores detailed characteristics of disturbances or outages; trigger recording by a user-defined setpoint, or from external equipment
Harmonic distortion	Up to 63rd harmonic (511th for ION7650 via ION Enterprise software) for all voltage and current inputs
Sag and swell detection	Analyze severity/potential impact of sags and swells: magnitude and duration data suitable for plotting on voltage tolerance curves per phase triggers for waveform recording and control
Disturbance direction detection	Determine the location of a disturbance more quickly and accurately by determining the direction of the disturbance relative to the meter; analysis results are captured in the event log, along with a timestamp and confidence level indicating level of certainty
Instantaneous	High-accuracy (1s) or high-speed (1/2 cycle) measurements, including true RMS per phase/total for: voltage and current active power (kW) and reactive power (kvar) apparent power (kVA power factor and frequency voltage and current unbalance phase reversal
Load profiling	Channel assignments (800 channels via 50 data recorders) configurable for any measurable parameter, including historical trend recording of energy, demand, voltage, current, power quality, or any measured parameter; trigger recorders based on time interval, calendar schedule, alarm/event condition, or manually
Trend curves	Access historical data at the front panel; display trend and continuously update historical data with date and timestamps for up to four parameters simultaneously
Waveform captures	Simultaneous capture of all voltage and current channels sub-cycle disturbance capture: maximum cycles is 214,000 (16 samples per cycle x 96 cycles, 10MB memory) 256 samples per cycle (ION7550) 512 samples per cycle standard, 1024 samples per cycle optional (ION7650) COMTRADE waveform format available direct from the meter (Ethernet port option only)
Alarms	Threshold alarms: adjustable pickup and dropout setpoints and time delays, numerous activation levels possible for a given type of alarm, user-defined priority levels, boolean combination of alarms is possible using the operators NAND, OR, NOR and XOR
Advanced security	Up to 16 users with unique access rights. Perform resets, time syncs, or meter configurations on user privileges
Transformer correction	Correct for phase/magnitude inaccuracies in current transformers (CTs), potential transformers (PTs)
Memory	5 to 10 MB (specified at time of order)
Firmware update	Update via the communication ports
Display characteristics	
Integrated display	Backlit LCD, configurable screens
Languages	English, French, Spanish, Russian
Notations	IEC, IEEE

(1) Consult the ION7550/ION7650 Installation Guide for complete specifications.

(2) IEC 62051-22B with serial ports only.

ADVANCED METERING

# ION7550/7650 series (cont.)

## Part numbers

Item	Code	Description
1 Model	S7650	Advanced meter with wide-range voltage inputs (57-347V line-neutral or 100-600V line-line), transient detection, data and waveform recording, IEC 61000-4-30 Class A & EN50160; supports ION, IEC 61850 (only for meters with 5MB memory and Ethernet comm card) Modbus-RTU, and DNP 3.0
	S7550	Advanced meter with wide-range voltage inputs (57-347V line-neutral or 100-600V line-line), sag and swell detection, data and waveform recording; supports ION, IEC 61850 (only for meters with 5MB memory and Ethernet comm card) Modbus-RTU, and DNP 3.0
2 Form factor	A0	Integrated display with front optical port, 5 MB logging memory, and 512 samples per cycle resolution (ION7650) or 256 samples per cycle (ION7550)
	A1	ION7650 only; integrated display with front optical port, 5 MB logging memory, and 1024 samples per cycle resolution
	B0	Integrated display with front optical port, 10 MB logging memory, and 512 samples per cycle resolution (ION7650) or 256 samples per cycle (ION7550)
	B1	ION7650 only; integrated display with front optical port, 10 MB logging memory, and 1024 samples per cycle resolution
	T0	Transducer (no display) version, with 5 MB logging memory, and 512 samples per cycle resolution (ION7650) or 256 samples per cycle (ION7550)
	T1	ION7650 only; transducer (no display) version, with 5 MB logging memory, and 1024 samples per cycle resolution
	U0	Transducer (no display) version, with 10 MB logging memory, and 512 samples per cycle resolution (ION7650) or 256 samples per cycle (ION7550)
3 Current inputs	C	5 amp nominal, 20-Ampm full-scale current input
	E	1 amp nominal, 10-Ampm full-scale current input
	F	Current probe inputs (for 0-1 VAC current probes; sold separately)
	G	Current probe inputs with three universal technic 10A clamp on CTs; meets IEC 1036 accuracy
4 Voltage inputs	0	57 to 347 VAC line-to-neutral/100 to 600 VAC line-to-line
5 Power supply	B	Standard power supply (85-240 VAC, ±10%/47-63 Hz/110-300 VDC, ±10%)
	C	Low-voltage DC power supply (20-60 VDC)
6 System frequency	5	Calibrated for 50 Hz systems
	6	Calibrated for 60 Hz systems
7 Communications	A0	Standard communications (1 RS-232/RS-485 port, 1 RS-485 port). Integrated display models include 1 ANSI Type 2 optical port
	C1	Standard communications plus 10BASE-T/100BASE-TX Ethernet (RJ45), 56k universal internal modem (RJ11); Ethernet and modem gateway functions each use a serial communications port
	D7	Standard communications plus 10BASE-T/100BASE-TX Ethernet (RJ45) and 100BASEFX Ethernet Fiber, 56k universal internal modem (RJ11); Ethernet/modem gateway uses serial port
	E0	Standard communications plus 10BASE-T/100BASE-TX (RJ45); Ethernet gateway function uses a serial communications port
	F1	Standard communications plus 10BASE-T/100BASE-TX Ethernet (RJ45) and 100BASE-FX (SC male Fiber Optic connection); Ethernet gateway function uses a serial port
	M1	Standard communications plus 56k universal internal modem (RJ11); Modem gateway function uses a serial port
8 I/O	A	Standard I/O (8 digital ins, 3 form C relays, 4 form A solid-state out)
	E	Standard I/O plus expansion I/O card (8 additional digital inputs and four 0 to 20 mA analog inputs)
	K	Standard I/O plus expansion I/O card (8 additional digital inputs and four 0 to 20 mA analog outputs)
	N	Standard I/O plus expansion I/O card (8 additional digital inputs and four 0 to 20 mA analog inputs and four 0 to 20 mA outputs)
	P	Standard I/O plus expansion I/O card (8 additional digital inputs and four 0 to 1 analog inputs and four -1 to 1 mA analog outputs)
9 Security	0	Password protected, no hardware lock
	1	Password protected, hardware lockable (enabled/disabled via jumper on comm card)
	6	Password protected with security lock enabled, terminal cover and UK OFGEM labels

**1 Model**  
**2 Form factor**  
**3 Current Inputs**  
**4 Voltage Inputs**  
**5 Power supply**  
**6 System frequency**  
**7 Communications**  
**8 Inputs/outputs**  
**9 Security**  
**10 Special order**

Example ION7650 product part number

ADVANCED METERING

# ION7550/7650 series (cont.)

Part numbers (cont.)

Item	Code	Description
10 Other options	A	None
	C	Tropicalization treatment applied
	E	ION7650 only; EN 50160 compliance monitoring, IEC 61000-4-30 class A measurements
	F	ION7650 only; EN 50160 compliance monitoring, with tropicalization treatment, IEC 61000-4-30 class A measurements
<b>Communications card</b>		
1 Comm card	P765C	ION7550/ION7650 communication card for field retrofit installations
2 Type	A0	Standard communications (1 RS-232/RS-485 port, 1 RS-485 port); integrated display models include 1 ANSI Type 2 optical port
	C1	Standard communications plus 10BASE-T/100BASE-TX Ethernet (RJ45), 56k universal internal modem (RJ11); Ethernet and modem gateway functions each use a serial communications port
	D7	Standard communications plus 10BASE-T/100BASE-TX Ethernet (RJ45) and 100BASEFX Ethernet Fiber, 56k universal internal modem (RJ11); Ethernet/modem gateway uses serial port
	E0	Standard communications plus 10BASE-T/100BASE-TX (RJ45); Ethernet gateway function uses a serial communications port
	F1	Standard communications plus 10BASE-T/100BASE-TX Ethernet (RJ45) and 100BASE-FX (SC male Fiber Optic connection); Ethernet gateway function uses a serial port
	M1	Standard communications plus 56k universal internal modem (RJ11); modem gateway function uses a serial port
3 Special order	A	None
	C	Tropicalization treatment applied
<b>Input/Output expansion card</b>		
I/O card	P760A	Expansion I/O for field retrofit installations
	E	Expansion I/O card with eight digital inputs, four 0 to 20 mA analog inputs
	K	Expansion I/O card with eight digital inputs, four 0 to 20 mA analog outputs
	N	Expansion I/O card with eight digital inputs, four 0 to 20 mA analog inputs & four 0 to 20 mA outputs
	P	Expansion I/O card with eight digital inputs, four 0 to 1 analog inputs and four -1 to 1 mA analog outputs
Special order	A	None
	C	Tropicalization treatment applied

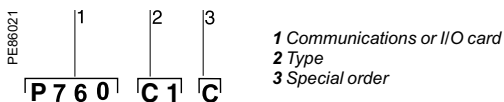

Example order code. Use this group of codes when ordering the PowerLogic™ ION7550/7650 communications or I/O cards.

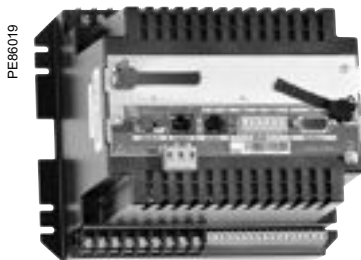

PowerLogic™ ION7550 TRAN

ION7550/ION7650 related items	
Description	Commercial ref. no.
Adapter plate to fit meter into a 3710 or 3720 ACM panel cutout	ADPT-37XX-7500
Terminal strip cover for the ION7550 or ION7650	TERMCVR-7500
10 A/1 V AC Universal Technic Clamp On Current Probe	M1UB10A1V-10A
1000 A/1 V AC Universal Technic Clamp On Current Probe	P32UEP813-1000A
3000 A/1 V AC Universal Technic Clamp On Current Probe	P32UEP815-3000A
5 A/0.333 V AC Magnelabs Split Core Current Probe	SCT0750-005-5A
300 A/0.333 V AC Magnelabs Split Core Current Probe	SCT1250-300-300A

\* Firmware version 350 or higher required.

# ION7550/7650 series (cont.)

## ION7550/ION7650 dimensions

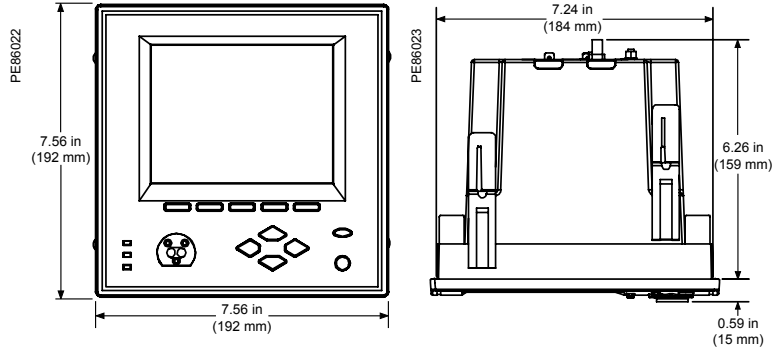

## ION7550/ION7650 TRAN dimensions

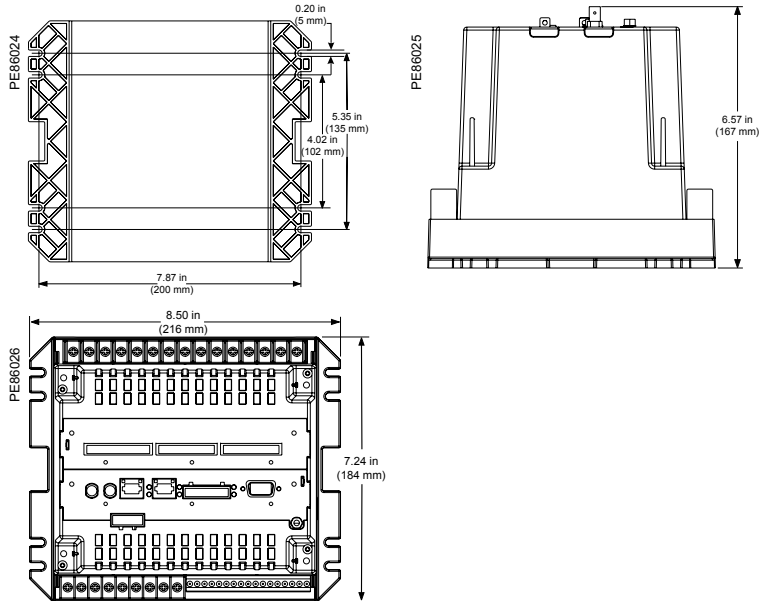

## Front-panel mounting

ION7550 and ION7650 meters can have either integrated or remote display. The meter with integrated display is designed to fit a DIN standard 192 cutout 7.32 x 7.32 in (186 x 186 mm). The remote display is installed through a circular cutout (0.86 in [22.5 mm], diameter) at the panel door and it has a front and a back module connected to the meter mounted in a DIN rail at the back.

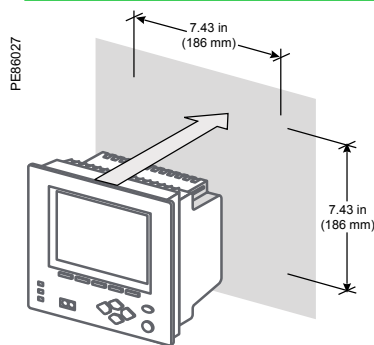

See appropriate Installation Guide for this product.

NOTES

---

## ADVANCED METERING

# Circuit monitor series 4000

The PowerLogic CM4000T circuit monitor offers high-performance digital instrumentation, data acquisition, and control capabilities. It can integrate easily in power monitoring and control systems due to its optional Ethernet connections and embedded web server. They are transparent ready.

These devices are designed for applications where power quality and availability are critical factors. They are generally used at service entrances and interconnection points, or on circuits feeding sensitive equipment. Due to their very wide range of features, including transient detection, it is possible to rapidly solve problems related to poor power quality. EN 50160 compliance-checking capability makes these products ideal to meet the needs related to market deregulation.

## Applications

- Panel instrumentation
- Sub-billing/cost allocation
- Remote monitoring of an electrical installation
- Extensive power quality monitoring
- Contract and load-curve optimization
- EN 50160 electrical supply compliance checking
- Metering of other utilities



CM4000 + vacuum fluorescent display (VFD)

## ADVANCED METERING

### The solution for

Markets that can benefit from a solution that includes circuit monitor series 4000:

- Buildings
- Industry
- Healthcare
- Data centers and networks
- Infrastructure

### Benefits

- Makes understanding power quality simple to help operations personnel avoid downtime and ensure increased productivity and equipment life
- Makes energy and power quality immediately relevant and actionable to support your operational and sustainability goals
- Optimizes availability and reliability of electrical systems and equipment
- Reduces energy costs

### Competitive advantages

- Disturbance direction detection
- Integrates easily due to optional Ethernet connections

### Conformity of standards

- IEC 62053-22 and ANSI C12.20 Class 0.2S
- EN 50160

### Main characteristics

- Disturbance direction detection
  - Indication of whether the source of a specific power quality event is upstream or downstream from the meter
- Power quality summary
  - Consolidation of all the power quality characteristics into a single trendable index
- Adaptive waveform capture
  - Capture of long-duration events
- Shift energy summary
  - Indication of energy usage per shift up to three shifts a day
- Detection and capture of voltage sags and swells
  - Fast identification of problems causing production shutdown
- Detection and capture of short transients less than 1  $\mu$ s
  - Identification of problems due to short disturbances, e.g., switching of capacitors, etc.
- Flicker evaluation based on IEC 61000-4-15 and IEEE 1453
  - Measurement of rapid voltage variations
- Detection of major waveform changes
  - Detection of phase switching phenomena (for example during the transfer of a high-speed static switch) not detected by classical threshold-based alarms
- Ultra-fast recording of electrical parameters every 100 ms or every cycle
  - Preventive maintenance: acquisition of a motor startup curve, etc.
- Trend curves and short-term forecasting
  - Rapid trending and forecasting of upcoming values for better decision making
- Automatic alarm setting
  - Alarm setpoint learning feature for optimum threshold settings
- 32 MB of memory
  - For archiving of data and waveforms
- Ethernet 10/100 Mb/s card and server for HTML pages (with optional Ethernet card)
  - Rapid data transfers over an intranet or the internet, simply using a web browser
- Alarm notification via email
  - High-priority alarms sent directly to the user's PC; instant notification of power quality events by email
- Up to 25 inputs/outputs to monitor the electrical installation (with optional I/O cards)
  - Status of circuit breakers, as well as metering of other commodities, e.g., gas, water, etc.
- IEC 62053-22 and ANSI C12.20 Class 0.2S for energy
  - Verification of consumption and load curves

# Circuit monitor series 4000

## Functions and characteristics (cont.)

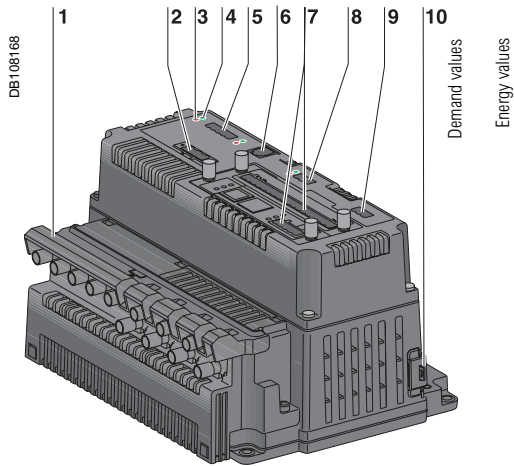

CM4000 series

- 1 Current/voltage module
- 2 Control power-supply connector
- 3 Maintenance LED indicator
- 4 Power LED indicator
- 5 RS 485 port with transmit and receive LED indicators
- 6 Display communication port
- 7 Slots for optional cards
- 8 RS 232 port with transmit and receive LED indicators
- 9 KYZ pulse output
- 10 Sealable access door

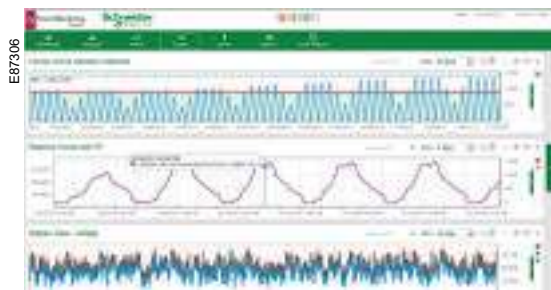

Disturbance waveform capture: detection of a voltage sag

Commercial reference numbers		Commercial ref. no.
Circuit monitor series 4000		CM4000T
Circuit monitor CM4000T		CM4000T
Selection guide		CM4000T
General		
Use on LV and HV systems		■
Current and voltage accuracy		0.07 %
Energy and power accuracy		0.2 %
Number of samples per cycle or sample frequency		5 MHz
Instantaneous RMS values		
Current, voltage, and frequency		■
Active, reactive, and apparent power	Total and per phase	■
Power factor	Total and per phase	■
Energy values		
Active, reactive, and apparent energy		■
Settable accumulation modes		■
Demand values		
Current	Present and max values	■
Active, reactive, and apparent power	Present and max values	■
Predicted active, reactive, apparent power		■
Synchronization of the measurement window		■
Setting of calculation mode	Block, sliding	■
Power quality measurements		
Interharmonics		-
Harmonic distortion	Current and voltage	■
Individual harmonics	Via monitor	63
	Via SMS	255
Waveform capture		■
Detection of voltage swells and sags		■
Adaptive waveform capture (up to 64 s)		■
Detection and capture of transients (< 1 μs)		■
Flicker		■
Fast acquisition of 100 ms or cycle-by-cycle data		■
EN 50160 compliance checking *		■
Programmable (logic and math functions)		■
Data recording		
Min/max of instantaneous values		■
Data logs		■
Event logs		■
Trending/forecasting		■
Alarms (optional automatic alarm setting)		■
Alarm notification via email		ECC21 option
SER (sequence of event recording)		■
Timestamping		■
GPS synchronization (1 ms)		IOC44 option
Memory expandable up to		32 MB
Display and I/O		
Display		CMDLC or CMDVF option
Multilingual: English, French, Spanish, German, Italian, Polish		■
Wiring self-test		■
Pulse output		■
Maximum number of I/Os		25
Input metering capability (number of channels)		10
Direct voltage connection		600 V
Communication		
RS-485 port		2/4 wires
RS-232 port		■
Modbus protocol		■
Ethernet card (Modbus/TCP/IP protocol)		ECC21 option
HTML-page web server		ECC21 option
Ethernet gateway for third-party products		ECC21 option

\*Except for interharmonics, signaling voltages, flicker, and transients.

# Circuit monitor series 4000

## Functions and characteristics (cont.)

The circuit monitor has two optional display units, an LCD display and a vacuum fluorescent display (VFD). They may be used for local circuit-monitor setup and operation.



### CMDLC display

The circuit monitor has a back-lit LCD display with four lines and 20 characters per line. The display units has four navigation buttons, a contrast button, and a red LED alarm, and it connects to the circuit monitor with a 4.2 meter CAB 12 cable that is supplied with the display.

### Commercial reference numbers

		Commercial ref. no.
LCD display with CAB12 cable		CMDLC
Connection cables:	1.37 y (1.25 m)	CAB4
Circuit monitor <-> display	4 y (3.65 m)	CAB12
	10 y (9.14 m)	CAB30

### CMDVF display

The vacuum fluorescent display (VFD) has four lines with 20 characters per line. The display unit has four navigation buttons, a contrast button, and a red LED alarm, and connects to the circuit monitor with a 4.2 meter CAB cable that is supplied with the display.

### Commercial reference numbers

		Commercial ref. no.
VFD with CAB 12 cable		CMDVF
Connection cables:	1.37 y (1.25 m)	CAB4
Circuit monitor <-> display	4 y (3.65 m)	CAB12
	10 y (9.14 m)	CAB30

Display

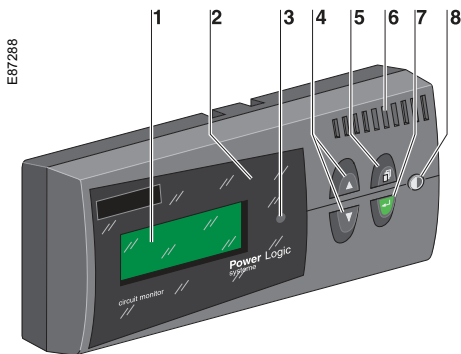

- 1 Display screen
- 2 Alarm LED
- 3 Arrow buttons
- 4 Menu button
- 5 Proximity sensor (VFD display only)
- 6 Enter button
- 7 Contrast button

Display

# Circuit monitor series 4000

## Functions and characteristics (cont.)



CM4000 + options: ECC21, IOC44, and IOX2411

Technical specifications		
Type of measurement		True RMS up to the 255th harmonic On three-phase AC system (3P 3P + N) Up to 512 samples per cycle Up to 5 MHz for transient events (CM4000T only)
Measurement accuracy	Current and voltage	±0.04 % of reading + ±0.025 % of full scale
	Power	±0.075 % of reading + ±0.025 % of full scale
	Frequency	±0.01 Hz from 45 to 67 Hz ±0.1 Hz from 350 to 450 Hz
	Power factor	±0.002 from 0.5 leading to 0.5 lagging
	Energy	IEC 62053-22 and ANSI C12.20 Class 0.2S
Data update rate		1 s in normal mode
Input-voltage characteristics	Measured voltage	0 to 600 V AC on CM4000T (direct) 0 to 1200 kV AC (with external VT)
	Measurement range	0 to 1.5 Un
	Impedance	> 2 M
	Frequency measurement range	45 Hz to 67 Hz and 350 Hz to 450 Hz
Input-current characteristics	CT ratings	Adjustable from 5 A to 30,000 A
	Measurement range	5 mA to 10 A
	Permissible overload	15 A continuous 50 A for 10 seconds per hour 500 A for 1 second per hour
Power supply	Impedance	< 0.1
	Load	< 0.15 VA
	AC	100 to 275 V AC (±10 %), 50 VA
	DC	125 to 250 V DC (±20 %), 30 W
Ride-through time		100 ms at 120 V DC
Input/outputs	Pulse output	Static output (240 V AC max, 96 mA max)
	IOC44 card (optional)	4 digital inputs (20-138 V AC/DC), 3 relay outputs (5 A to 240 V AC) 1 static output (96 mA max to 240 V AC)
	IOX extender (optional)	Slots for 8 I/Os
	IOX08 (optional)	8 digital inputs 120 V AC
	IOX0404 (optional) ★	4 digital inputs 120 V AC, 4 analog outputs 4-20 mA
	IOX2411 (optional) ★	2 digital outputs 120 V AC, 4 digital inputs 32 V DC, 1 analog input 0-5 V, 1 analog output 4-20 mA

Mechanical characteristics		
Weight		4.19 lb (1.9 kg)
IP degree of protection (IEC 60529)		IP52
Dimensions	Without IOX accessory	9.27 x 6.52 x 5.24 in (235.5 x 165.6 x 133.1 mm)
	With IOX accessory	9.27 x 8.52 x 5.24 in (235.5 x 216.3 x 133.1 mm)

Environmental conditions		
Operating temperature	Circuit monitor	-25 °C to 70 °C
	CMDLC display	-20 °C to 60 °C
	CMDVF display	-20 °C to 70 °C
Storage temperature	CM + displays	-40 °C to 85 °C
Humidity rating		5% to 95% RH at 40 °C
Pollution degree		2
Installation category	CVM42	IV
	CVMT	II
Dielectric withstand		As per EN 61010, UL508, CSA C22.2-2-4-M1987

Electromagnetic compatibility		
Electrostatic discharge		Level 3 (IEC 61000-4-2)
Immunity to radiated fields		Level 3 (IEC 61000-4-3)
Immunity to fast transients		Level 3 (IEC 61000-4-4)
Immunity to impulse waves		Level 4 (IEC 61000-4-5)
Conducted and radiated emissions		CE industrial environment/FCC part 15 class A

Safety		
U.S. and Canada		UL508 and CSA C22.2-2-4-M1987

★ Operating limits: 0 °C to +60 °C  
Storage limits: -25 °C to +85 °C

# Circuit monitor series 4000

## Functions and characteristics (cont.)

E100279



EcoStruxure provides many different report templates that allow users to easily display and deliver the information they need

E100280

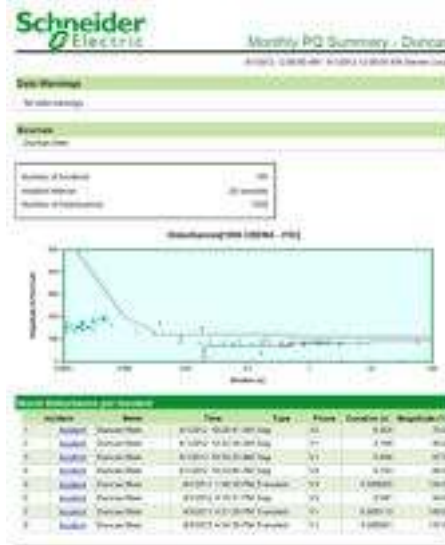

Power Quality Summary Report example

E87309



Example CM4250 HTML page showing instantaneous values

Communication	
RS-485 port *	2/4 wires, up to 38400 baud, Modbus
RS-232 port *	Up to 38400 baud, Modbus, direct connection to a PC or modem
Ethernet ECC21 card with HTML server (optional) <sup>(1)</sup>	
Copper Ethernet link	10/100 BASE-TX, RJ45 connector, 100 m link
Fiber optic Ethernet link	100BASE-FX, LC duplex connector, 1300 nm, FO multimode with gradient index 62.5/125 μm or 50/125 μm, 2000 m link
Protocol	Modbus/TCP/IP
Gateway function for products connected to the ECC21	Master Modbus port, 31 daisy-chained slaves, 63 with repeater, 2/4 wires, 1200 to 38400 baud, also compatible with the PowerLogic protocol
HTML server	1 standard page, 5 customizable pages
Firmware characteristics	
14 data logs	Up to 96 different parameters, factory-set logs ready to use
One 100 ms data log	Parameters recorded every 100 ms for events
One 20 ms (50 Hz) or 16 ms (60 Hz) data log	Parameters recorded every 20 ms or 16 ms for events
One min/max log	—
One min/max/avg log	Min/max/avg values recorded for 23 parameters at regular intervals from 1 to 1440 minutes
One event log	Time stamping to 1 ms, synchronized 1 ms by GPS
Trend curves	Four trend curves: 1 minute, 1 hour, 1 day, and 1 month Min/max/avg values recorded for eight parameters: - every second for one minute for the 1-minute curve - every minute for one hour for the 1-hour curve - every hour for one day for the 1-day curve - every day for one month for the 1-month curve
Forecasting	Forecasting of the values for the eight parameters for the next four hours and next four days
Waveform captures	Standard: manual launch, 1 cycle, 512 samples, 255 <sup>th</sup> harmonic Disturbance: manual launch or by alarm, adjustable from 512 samples per cycle over 28 cycles to 16 samples per cycle over 915 cycles, response time less than 0.5 cycles, number of cycles before alarm settable from 2 to 10 Adaptive: manual launch or by alarm, adjustable from 512 samples per cycle over 8 seconds to 16 samples per cycle over 264 seconds, capture takes place during a set duration or as long as an alarm is active (to save memory), number of cycles before alarm settable from 2 to 10 Transient: voltage sampling at 5 MHz 83 333 samples per cycle over 2 ms to capture transient peaks < 1 μs
Alarms	Threshold alarms: - adjustable pickup and dropout setpoints and time delays, numerous activation levels possible for a given type of alarm - 4 priority levels - 4 response times: standard 1 s, fast 100 ms, disturbance < 1/2-cycle, transient < 1 μs - Boolean combination of four alarms is possible using the operators NAND, OR, NOR, and XOR  Automatic alarm setting: after a learning phase, the alarm thresholds are set automatically. The alarms will trip in the event of drift with respect to reference values determined during the learning period. Digital alarms: logic input transitions Waveform alarms: alarm tripping by a special algorithm when the current or voltage waveform is distorted beyond an adjustable level, making it possible to detect disturbances that cannot be detected by classical threshold alarms (e.g., phase switching)
Memory	8 MB standard, expandable to 32 MB
Firmware update	Update via the communication ports
Display characteristics	
CMDLC (optional)	Backlit LCD
CMDVF (optional)	Vacuum fluorescent display (VFD) with IR port
Languages	English, French, Spanish, German, Italian, and Polish

\* All communication ports may be used simultaneously.

# Circuit monitor series 4000

## Dimensions and connection

### CM4000T dimensions

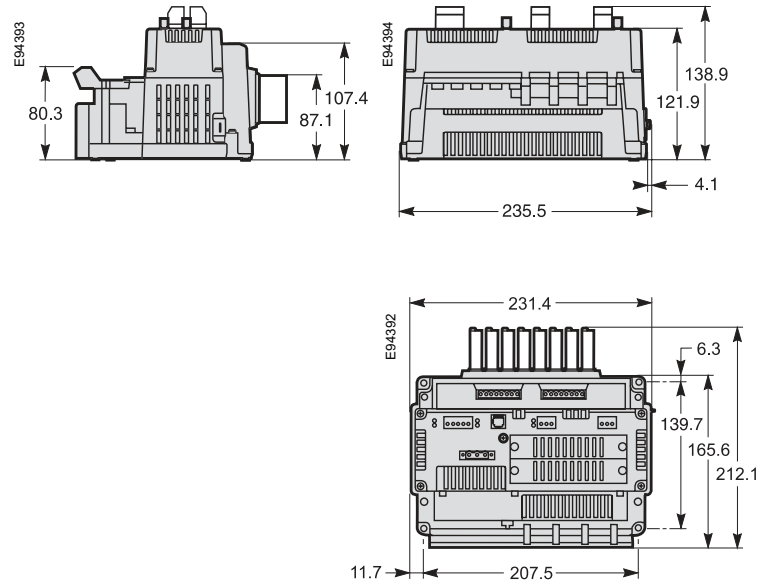

### Mounting on a backplate

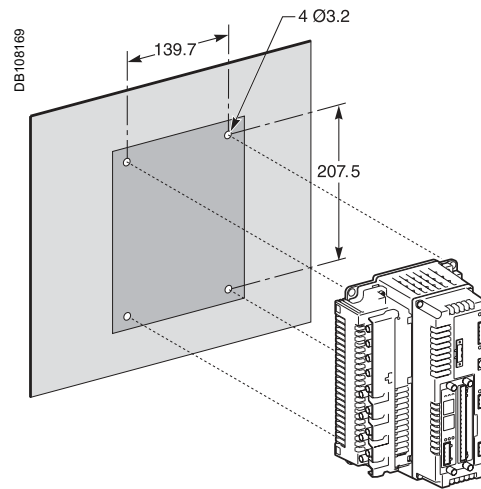

# Circuit monitor series 4000

## Dimensions and connection (cont.)

### Mounting possibilities

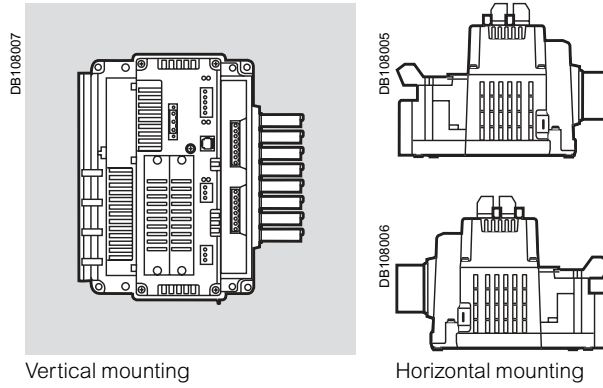

### CMDLC/CMDVF dimensions

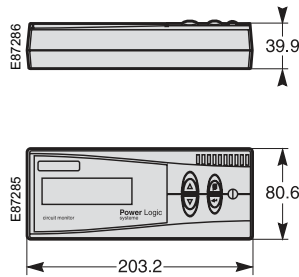

### Mounting on a backplate

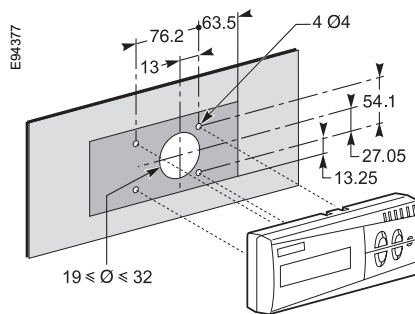

## ION9000 Series

The PowerLogic™ ION9000 is your 24/7 power quality expert, providing information, not just data.

This meter offers a comprehensive and industry leading Power Quality Instrument (PQI) performance designation according to IEC 62586-1/-2. It provides the highest accuracy in industry according to ANSI C12.20 Class 0.1 and IEC 62053-22 Class 0.1S. Third-party, lab-verified power quality, accuracy and safety ensure reliable performance and demonstrates the meter's suitability for both supply and demand side applications.

Identify the source of power quality issues faster with our patented Disturbance Direction Detection. Protect your future through highly customizable modularity and field programmability to satisfy any solution. All backed by Schneider Electric's global services and support.

### Applications

Ideal for low to high voltage applications in industrial facilities, data centers, infrastructure and other critical power environments.

PB115917



### The market solution for

Markets that benefit from a solution that includes PowerLogic ION9000 series meters:

- Data centers
- Healthcare facilities
- Semiconductor
- Pharmaceutical and chemical
- Energy industries
- Mining, Minerals, and Metals
- Renewable energy interconnects
- Medium voltage distribution, and energy automation

---

### Benefits

- Makes understanding power quality simple which helps operations personnel avoid downtime and increase productivity and equipment life
- Makes energy and power quality data immediately actionable and relevant to operational and sustainability goals

---

### Competitive advantages

- Modular, flexible, patented ION™ programmable technology
- Utility grade energy accuracy
- Patented Disturbance Direction Detection
- Third-party, lab-verified compliance with latest PQ standards
- Onboard pass/fail PQ characterization and assessment according to EN50160 and IEEE519
- Cybersecurity event logging, Syslog protocol, HTTPS, and full control of each communication port

### Conformity of standards

- ANSI C12.20
- ANSI C37.90.1
- IEC 61000-4-15
- IEC 61000-4-30
- IEC 61010-1
- IEC 61326-1
- IEC 61557-12
- IEC 61850
- IEC 62052-11
- IEC 62052-31
- IEC 62053-22
- IEC 62053-23
- IEC 62053-24
- IEC 62586
- UL 61010-1

ADVANCED METERING



PowerLogic™ ION9000 series meter with RD192 display



PowerLogic™ ION9000 RD192 remote display



PowerLogic™ ION9000 front view

Main characteristics

- PQ compliance reporting and basic PQ analysis:
  - Monitors and logs parameters in support of international PQ standards:
    - IEC 61000-4-30 Class A (test methods as per IEC 62586-2).
  - High resolution waveform capture: triggered manually or by alarm. Captured waveforms available directly from the meter via FTP in a COMTRADE format, and viewable in the meter's web interface.
  - Generates onboard PQ compliance reports accessible via onboard web pages:
    - Pass/fail report for IEEE 519 for voltage and current harmonic limits.
    - ITIC (CBEMA) and SEMI curves, with alarm categorization to support further analyses.
    - NEMA Motor Derating curve.
  - Harmonic analysis:
    - THD and TDD per phase, min/max, custom alarming.
    - Individual harmonic magnitudes and angles on voltage and current, up to the 63rd harmonic.
  - Disturbance detection and capture: sag/swell on any current and voltage channel, alarm on disturbance event, waveform capture with pre-event information.
  - Patented Disturbance Direction Detection: provides indication of the captured disturbance occurring upstream or downstream of the meter; timestamped results provided in the event log, with degree of certainty of disturbance direction.
- Transient capture of events 20 microseconds or longer in duration on any voltage channel with waveform capture and pre-event information.
- Metering precision:
  - IEC 61557-12 PMD/SD/K70/0.2 and PMD/SS/K70/0.2 3000m (Performance Measuring and Monitoring devices (PMD)).
  - Class 0.1S accuracy IEC 62053-22, ANSI C12.20 Class 0.1 (active energy).
  - Industry leading Class 0.5S accuracy for reactive energy (IEC 62053-24).
  - Cycle-by-cycle RMS measurements updated every ½ cycle.
  - Full 'multi-utility' WAGES metering support.
  - Net metering.
  - Anti-tamper protection seals and hardware metrology lock.
- Cybersecurity:
  - Security events logging with Syslog protocol support.
  - HTTPS secure protocol.
  - Ability to enable or disable any communication port and any protocol per port.
  - Anti-tamper protection seals and hardware metrology lock.
  - User accounts with strong passwords.

ADVANCED METERING



PowerLogic ION9000 with panel mounting adapter



PowerLogic ION9000 front with two option modules



PowerLogic ION9000 bottom with two option modules

- Used with Schneider Electric's advanced software tools, provides detailed PQ reporting across entire network:
  - EN 50160 compliance report.
  - IEEE 519 harmonic compliance report.
  - IEC 61000-4-30 report.
  - Power quality compliance summary.
  - Energy reports for consumption analysis and cost management.
  - WAGES dashboards and reports.
  - Display of waveforms and PQ data from all connected meters.
  - Onboard web-based waveform viewer.
  - EcoStruxure Power Events Analysis, including alarm management, sequence of events, and root cause analysis.
  
- Data and event logging:
  - Onboard data and event logging.
  - 2 GB of standard non-volatile memory.
  - No data gaps due to network outages or server downtime.
  - Min/max log for standard values.
  - 100 user-definable data logs, recording up to 16 parameters at a 1/2 cycle or other user definable interval.
  - Continuous logging or snapshot, triggered by setpoint and stopped after defined duration.
  - Trend energy, demand, and other measured parameters.
  - Forecasting via web pages: average, minimum and maximum for the next four hours and next four days.
  - Advanced time-of-use capability.
  - Security/event log: alarm conditions, metering configuration changes, power outages, firmware download, and user login/logout with timestamp.
  
- Alarming and control:
  - 50+ definable alarms to log critical event data, trigger waveform recording, or perform control function.
  - Trigger on any condition, with 1/2-cycle and 1-second response time.
  - Combine alarms using Boolean logic enabling customization of alarms.
  - Alarm notification via email.
  - In conjunction with Schneider Electric's EcoStruxure software, alarms, software alarms, and alarm frequency are categorized and trended enabling sequence of events and root cause analyses.

Usability

- On-board, full function web server enables simple web commissioning:
  - Panel and DIN rail mounting options, remote display option.
  - Pluggable connectors.
  - Free setup wizard simplifies meter configuration.
  - Auto-discovery using DPWS (Device Profile Web Services).
  - DHCP for automatic IP address configuration.
  
- Front panel:
  - Easy to read color graphic display.
  - Simple and intuitive menu navigation with multiple language interface and support.

ADVANCED METERING



PowerLogic ION9000 Harmonics display

- Flexible remote communications:
  - Multiple simultaneously operating communication ports and protocols allow interfacing with other automation systems, e.g. waveforms, alarms, billing data, etc. Data can be uploaded for viewing/analysis while other systems access real-time information.
  - Supports: Modbus, ION, DNP3, DLMS, SNMP, and IEC 61850.
  - Dual port Ethernet: 2x 10/100BASE-TX; supports IPV4 and IPV6; daisy-chaining capability removes need for additional switches.
  - Create redundant network loop using Rapid Spanning Tree Protocol (RSTP) and managed Ethernet switches.
  - Secure web interface with HTTPS and TLS 1.2 with support for user-provided certificates.
  - Customize TCP/IP port numbers and enable/disable individual ports.
  - RS-485 2-wire connection, up to 115,200 baud.
  - Ethernet to serial gateway with Modbus Master functionality, connecting to 31 unit loads of downstream serial Modbus devices. Also supports Modbus Mastering over TCP/IP (Ethernet) network.
  - Full function web server with factory and customizable pages to access real-time and PQ compliance data.
  - Push historical data via email.
  - Advanced network security: Up to 50 configurable user accounts.
  
- Time synchronization via:
  - Precision network time protocol (PTP) based on IEEE 1588 / IEC 61588.
  - GPS clock (RS-485) or IRIG-B (digital input) to  $\pm 1$  millisecond.
  - Network Time Protocol (NTP/SNTP).
  - Automatic time synchronization available through Schneider Electric software server.

Adaptability

- ION™ frameworks are customizable, scalable applications with object-oriented programming that compartmentalizes functions, and increases flexibility and adaptability.
- Applications include: access and aggregate data from Modbus devices on serial port or across the network (Modbus TCP/IP), logging and/or processing data by totaling, unit conversion or other calculations, applying complex logic for alarming or control operations, data visualization via web pages.

Standard meter I/O

- Eight digital status/counter inputs with  $\pm 1$  millisecond timestamp.
- Four solid state digital outputs (Form A) for energy pulsing, interfacing with other systems or control.
- Two Form C relay outputs for control applications.

Modular I/O options

- Optional expansion modules.
- Up to four modules per meter.

Option modules include:

- Digital module:
  - Six digital status/counter inputs.
  - Two Form C relay outputs, 250 V AC, 8 A.
  
- Analog module:
  - Four analog inputs (4-20 mA; 0-30 V).
  - Two analog outputs (4-20 mA; 0-10 V) for interfacing with building management sensors and systems.

# ION9000 series

Feature Guide		ION9000
<b>General</b>		
Use on LV, MV, and HV systems		■
Current accuracy		0.1 % reading
Voltage accuracy		0.1 % reading
Active energy accuracy		0.1 Class
Number of samples/cycle or sample frequency		1024
<b>Instantaneous rms values</b>		
Current, voltage, frequency		■
Active, reactive, apparent power		Total and per phase
Power factor		Total and per phase
<b>Energy values</b>		
Active, reactive, apparent energy		■
Settable accumulation modes		■
<b>Demand values</b>		
Current		Present and max. values
Active, reactive, apparent power		Present and max. values
Predicted active, reactive, apparent power		■
Synchronization of the measurement window		■
Setting of calculation mode		Block, sliding
<b>Power Quality measurements</b>		
Harmonic distortion		Current and voltage
Individual harmonics		via front panel and web page: 63 via EcoStruxure™ software: 511
Interharmonics		■
Waveform capture		■
Detection of voltage swells and sags		■
Fast acquisition		1/2 cycle data
EN 50160 and IEEE 519 compliance checking		■
Customizable data outputs (using logic and math functions)		■
<b>Data recording</b>		
Min/max of instantaneous values		■
Data logs		■
Event logs		■
Trending/forecasting		■
SER (Sequence of event recording)		■
Time stamping		■
PTP, IRIG-B, and GPS time synchronization ( $\pm$ 1ms)		■
Memory		2000 MB
<b>Display and I/O</b>		
Front panel display, 2 options		3.78 in (96 mm) and 7.56 (192 mm)
Pulse output		2
Digital or analog inputs (max)		32 digital, 16 analog
Digital or analog outputs (max, including pulse output)		4 digital, 10 relay, 8 analog
<b>Communication</b>		
RS-485 port(s)		2
Ethernet port(s)		2x 10/100BASE-TX, RJ45 connector, CAT5/5e/6/6a cable
Serial port protocols (Modbus, ION, DNP3, DLMS)		■
Ethernet port protocols (Modbus, ION, DNP3, DLMS, IEC 61850)		■
Ethernet gateway		■
Alarm notification via email		■
HTTP/HTTPS web server with waveform viewer		■
SNMP with custom MIB and traps for alarms		■
SMTP email		■
PTP and NTP time synchronization		■
FTP file transfer		■

# ION9000 series

## Technical specifications

Electrical characteristics		
Type of measurement		True rms to 1,024 samples per cycle
Measurement accuracy	Current & voltage	Class 0.1 as per IEC 61557-12
	Active Power	Class 0.1 as per IEC 61557-12
	Power factor	Class 0.5 as per IEC 61557-12
	Frequency	Class 0.02 as per IEC 61557-12
	Active energy	Class 0.1S IEC 62053-22 Class 0.1 IEC 61557-12 Class 0.1 ANSI C12.20
	Reactive Energy	Class 0.5S IEC 62053-24
Display refresh rate		HMI display updated once per second; data refresh rate 1/2 cycle or 1 second
Input-voltage characteristics	Specified accuracy voltage	57 - 400 V L-N / 100 - 690 V L-L
	Impedance	5 M $\Omega$ per phase
	Specified accuracy frequency	42 to 69 Hz (50/60 Hz nominal)
	Limit range of operation - frequency	20 to 450 Hz
Input-current characteristics	Rated nominal current	1 A (0.1S), 5 A (0.1S); current class 2, 10, 20 A (0.1 ANSI)
	Specified accuracy current range	Starting Current: 1 mA (no accuracy) Accurate Range: 10 mA - 20 A
	Permissible overload	500 A rms for 1.0s
	Impedance	0.0003 $\Omega$ per phase
	Burden	0.01 VA max at 5 A
Power supply AC/DC	AC	90-480 V AC $\pm$ 10 % (50/60 Hz $\pm$ 10 %) 90-120 V AC $\pm$ 10% (400 Hz)
	DC	110-480 V DC $\pm$ 15 %
	Ride-through time (Values for meters with no optional accessories)	100 ms (5 cycles at 50/60 Hz) typ., 120 V AC 400 ms (20 cycles at 50/60 Hz) typ., 240 V AC 1,200 ms (60 cycles at 50/60 Hz) typ., 480 V AC
	Burden	Typical: 16.5 W / 38 VA at 480 V (50/60 Hz) Fully optioned: max. 40 W / 80 VA at 480 V (50/60 Hz)
Input/outputs	Meter base Only	8 digital inputs (30 V AC/60 V DC) 4 Form A (KY) solid state digital output (30 V AC/60 V DC, 75 mA) 2 Form C relays (8 A at 250 V AC, 5 A at 24 V DC)
	Optional	Digital - 6 digital inputs (30 V AC / 60 V DC) wetted + 2 Form C relay outputs (250 V AC, 8 A)
		Analog - 4 analog inputs (4-20 mA, 0-30 V DC) + 2 analog outputs (4-20 mA, 0-10 V DC).
Mechanical characteristics		
Weight		DIN rail mount meter 3.31 lbs (1.5 kg) IO modules 0.31 lbs (0.140 kg) Touchscreen display 0.66 lbs (0.300 kg)
IP degree of protection		IP 65, UL type 12: Panel mount and touchscreen display, front IP 30: Panel mount rear, DIN rail mount, I/O modules
Excellent quality		ISO 9001 and ISO 14000 certified manufacturing
Dimensions	Panel mount	6.30 x 6.30 x 5.33 in (160 x 160 x 135.3 mm)
	DIN rail mount meter	6.30 x 6.30 x 5.33 in (160 x 160 x 135.3 mm)
	Color remote display (2 options)	7.76 x 6.89 x 1.08 in (197 x 175 x 27.5 mm) touchscreen 3.78 x 3.78 x 1.06 in (96 x 96 x 27 mm) pushbutton
	I/O modules	3.56 x 3.56 x 0.87 in (90.5 x 90.5 x 22 mm)
	Touchscreen display(s)	7.56 in and 3.78 in (192 mm and 96 mm)

# ION9000 series

Environmental conditions	
Operating temperature	-25 to 70 °C
Remote Display Unit	-25 to 60 °C
Storage temperature	-40 to 85 °C
Humidity rating	5 to 95% non-condensing
Installation category	III
Operating altitude (maximum)	3,000 m above sea-level
Electromagnetic compatibility	
EMC standards	IEC 62052-11, IEC 61326-1, IEC 61000-6-5
Immunity to electrostatic discharge	IEC 61000-4-2
Immunity to radiated fields	IEC 61000-4-3
Immunity to fast transients	IEC 61000-4-4
Immunity to surges	IEC 61000-4-5
Immunity to conducted disturbances	IEC 61000-4-6
Immunity to power frequency magnetic fields	IEC 61000-4-8
Immunity to conducted disturbances, 2-150kHz	CLC/TR 50579
Immunity to voltage dips and interruptions	IEC 61000-4-11
Immunity to ring waves	IEC 61000-4-12
Conducted and radiated emissions	EN 55011 and EN 55032 Class B, FCC part 15 Class B, ICES-003 Class B
Surge withstand Capability (SWC)	IEEE/ANSI C37.90.1
Safety	
Safety Construction	IEC/EN 61010-1 ed.3, CAT III, 400 V L-N / 690 V L-L UL 61010-1 ed.3 and CSA-C22.2 No. 61010-1 ed.3, CAT III, 347 V L-N / 600 V L-L IEC/EN 62052-31, protective class II
Communication	
Ethernet to serial line gateway	Communicates directly with up to 31 serial devices
Web server	Customizable pages, new page creation capabilities, HTML/XML compatible
Serial port RS-485	2x, Baud rates of 2,400 to 115,200, pluggable screw terminal connector
Ethernet port(s)	2x 10/100BASE-TX, RJ45 connector, CAT5/5e/6/6a cable
Protocol	HTTPS, FTP, SNMP, SMTP, DPWS, RSTR, PTR, NTP/SNTP, GPS, Syslog, DHCR, IPv4, IPv6
Firmware characteristics	
High-speed data recording	Down to 1/2 cycle interval recording, stores detailed characteristics of disturbances or outages. Trigger recording by a user-defined setpoint, or from external equipment.
Harmonic distortion	Up to 63rd harmonic (511th via Schneider Electric EcoStruxure software) for all voltage and current inputs
Sag/swell detection	Analyze severity/potential impact of sags and swells: magnitude and duration data suitable for plotting on voltage tolerance curves per phase triggers for waveform recording
Disturbance direction detection	Determine the location of a disturbance more quickly and accurately by determining the direction of the disturbance relative to the meter. Results are captured in the event log, along with a timestamp and confidence level indicating level of certainty.
Detection and capture of transients	As short as 20 µs at 50 Hz (17 µs at 60 Hz)
Instantaneous	High accuracy of standard speed (1s) and high-speed (1/2 cycle) measurements, including true rms per phase and total for: voltage, current, active power (kW), reactive power (kvar), apparent power (kVA), power factor, frequency, voltage and current unbalance, phase reversal
Load profiling	Channel assignments (1600 channels via 100 recorders) configurable for any measurable parameter, including historical trend recording of energy, demand, voltage, current, power quality, or any measured parameter. Trigger recorders based on time interval, calendar schedule, alarm/event condition, or manually.
Trend curves	Historical trends and future forecasts to better manage demand, circuit loading, and other parameters. Provides average, min, max, and standard deviation every hour for last 24 hours, every day for last month, every week for last 8 weeks and every month for last 12 months.

# ION9000 series

Firmware characteristics (cont.)	
Waveform captures	Simultaneous capture of voltage and current channels, sub-cycle disturbance captures of 180-cycles @ 1,024 samples/cycle to 7,200-cycles @ 16 sample/cycle, retriggerable
Alarms	Threshold alarms: adjustable pickup and dropout setpoints and time delays, numerous activation levels possible for a given type of alarm, user-defined or automatic alarm threshold settings, user-defined priority levels (optional automatic alarm setting)
Advanced Time of Use (TOU)	6 seasons; 3 different day types: weekend, weekday, and holiday; up to 8 tariffs per day type
Advanced network security	Up to 50 users with unique access rights. Perform resets, time sync, or meter configurations based on user privileges
Memory	2,000 MB
Firmware update	Update via the communication ports
Display characteristics	
96 mm pushbutton display	320 x 240 (1/4 VGA) color LCD, configurable screens, 5 buttons and 2 LED indicators (alarm and meter status)
192 mm touchscreen display	800 x 400 pixels, 177.8 mm (7") Color LCD, +/- 85 degree view angle, sunlight readable, dual capacitive touch, usable when wet or through Class 0 lineman gloves, impact resistant to 5 joules, IP65 rating
Languages	English, French, Spanish, Russian, Portugese, German, Italian, Chinese
Notations	IEC, IEEE
The HMI menu includes	
Alarms	Active alarms, historic alarms (50+ alarms)
Basic reading	Voltage, current, frequency, power summary
Power	Power summary, demand, power factor
Energy	Energy total, delivered, received
Events	Timestamped verbose event log
Power Quality	EN 50160, IEEE 519, harmonics, phasor diagrams
Inputs/Outputs	Digital inputs, digital outputs, relay outputs, analog inputs, analog outputs
Nameplate	Model, serial and FW version
Custom screens	Build your own metrics
Setup menu	Meter setup, communications setup, display setup, date/time/clock setup, alarm setup, language setup, time of use setup, resets, password setup

## ION9000 Commercial reference numbers

Commercial reference number	Description
METSEION92030	ION9200 meter, DIN mount, no display, HW kit
METSEION92040	ION9200 meter, DIN mount, 7.56 in (192 mm) display, B2B adapter, HW kit
METSEPM89RD96	Remote display, color LCD, 3.78 x 3.78 in (96 x 96 mm)
METSERD192	Remote display, color touchscreen, 7.56 x 7.56 in (192 x 192 mm)
METSEPM89M2600	I/O module, 2 relay outputs, 6 digital inputs
METSEPM89M0024	I/O module, 2 analog outputs, 4 analog inputs
METSE9HWK	ION9000 meter hardware kit – plugs, terminal guards, spare grounding screw, DIN clips
METSERD192HWK	RD192 remote display hardware kit
METSE9B2BMA	ION9000 B2B adapter
METSE9USBK	ION9000 USB cover hardware kit
METSE9CTHWK	ION9000 Current Input hardware kit – terminal screws, CT covers
METSE7x4MAK	ION7x50 Mounting Adapter Kit

Contact your Schneider Electric representative for complete ordering information.

ADVANCED METERING

# ION9000 series

## ION9000 meter dimensions

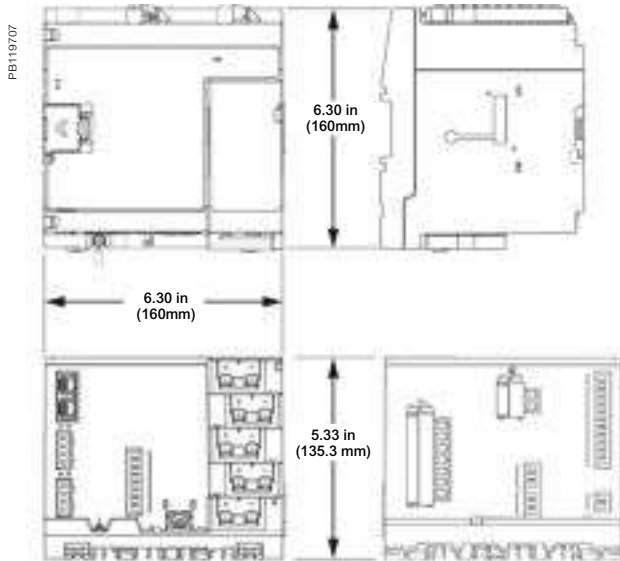

## ION9000 mounting template

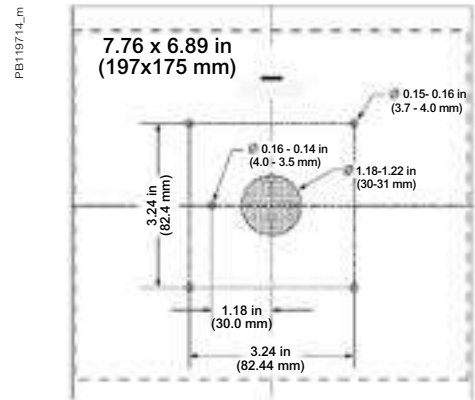

## ION9000 back-to-back (B2B) dimensions

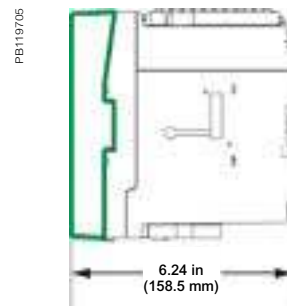

## ION9000 7.56 in (192 mm) display dimensions

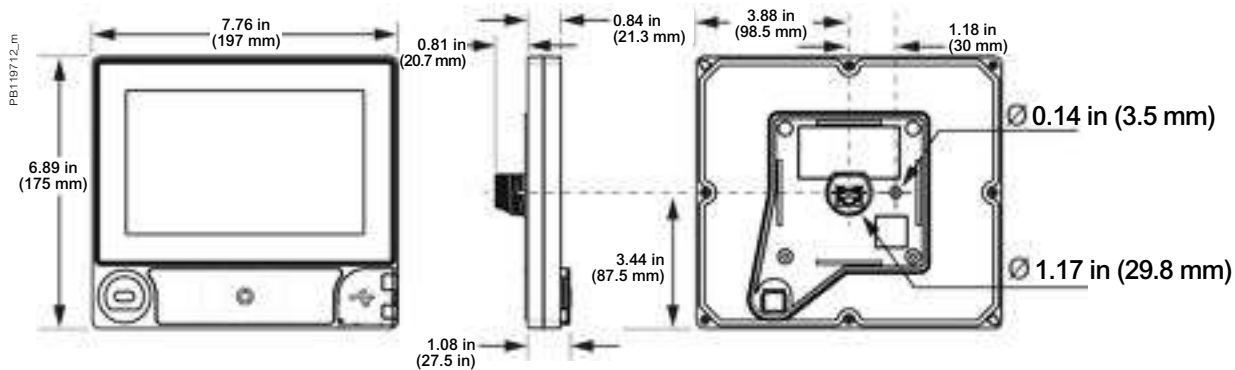

## ION9000 3.78 in (96 mm) display dimensions

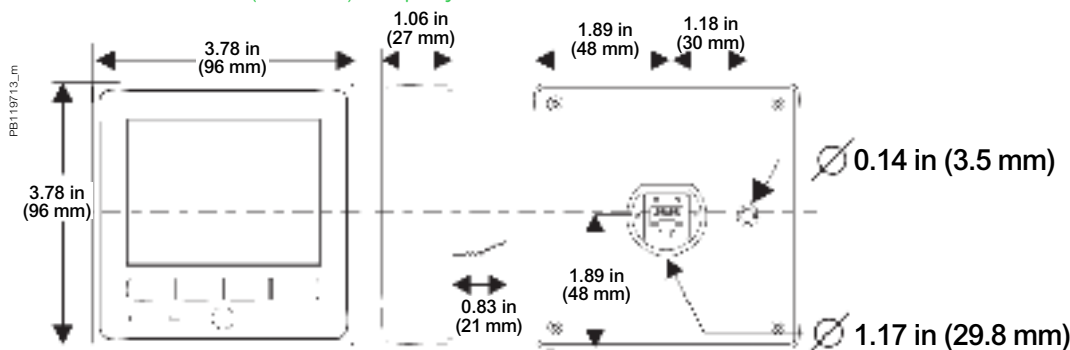

Please refer to ION9000 Series Meter Installation Sheet for accurate and complete information on the installation of this product.

ADVANCED METERING

# ION9000 series

## ION9000 meter DIN rail dimensions

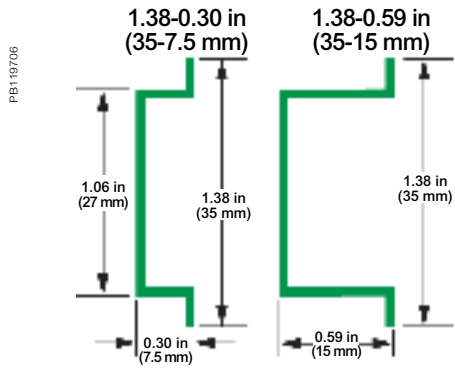

## ION7x50 mounting adapter dimensions

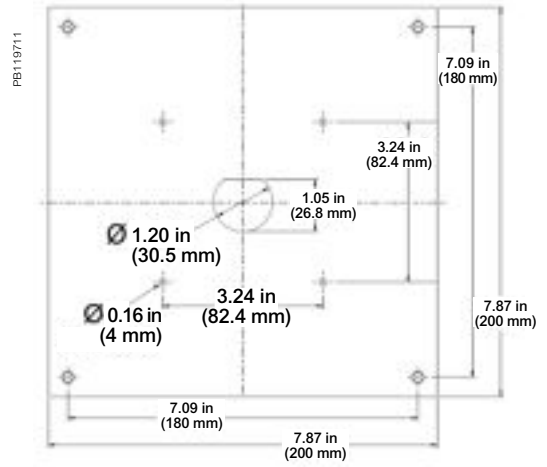

## ION9000 meter click installation

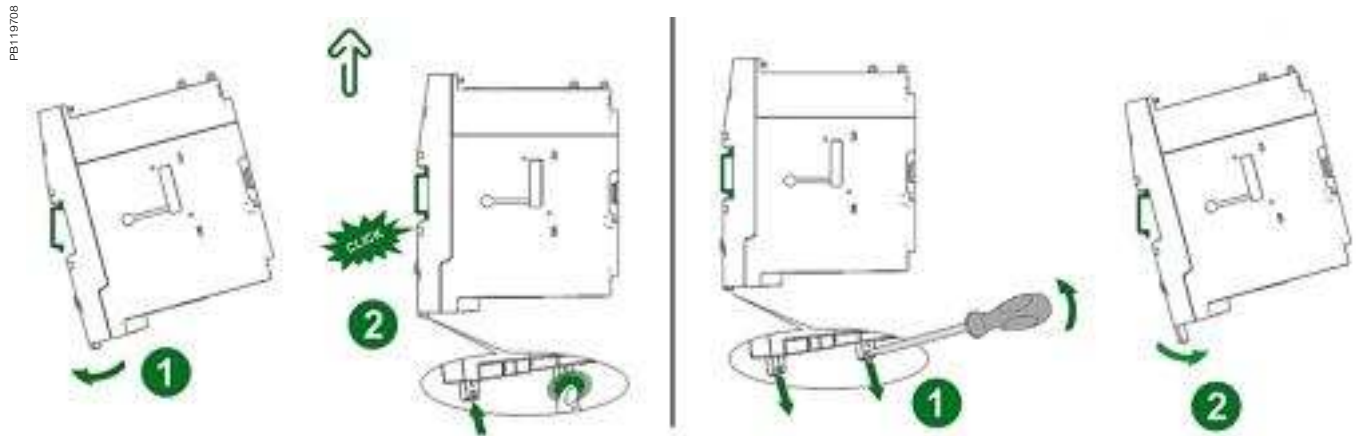

NOTES

---

# Advanced utility metering

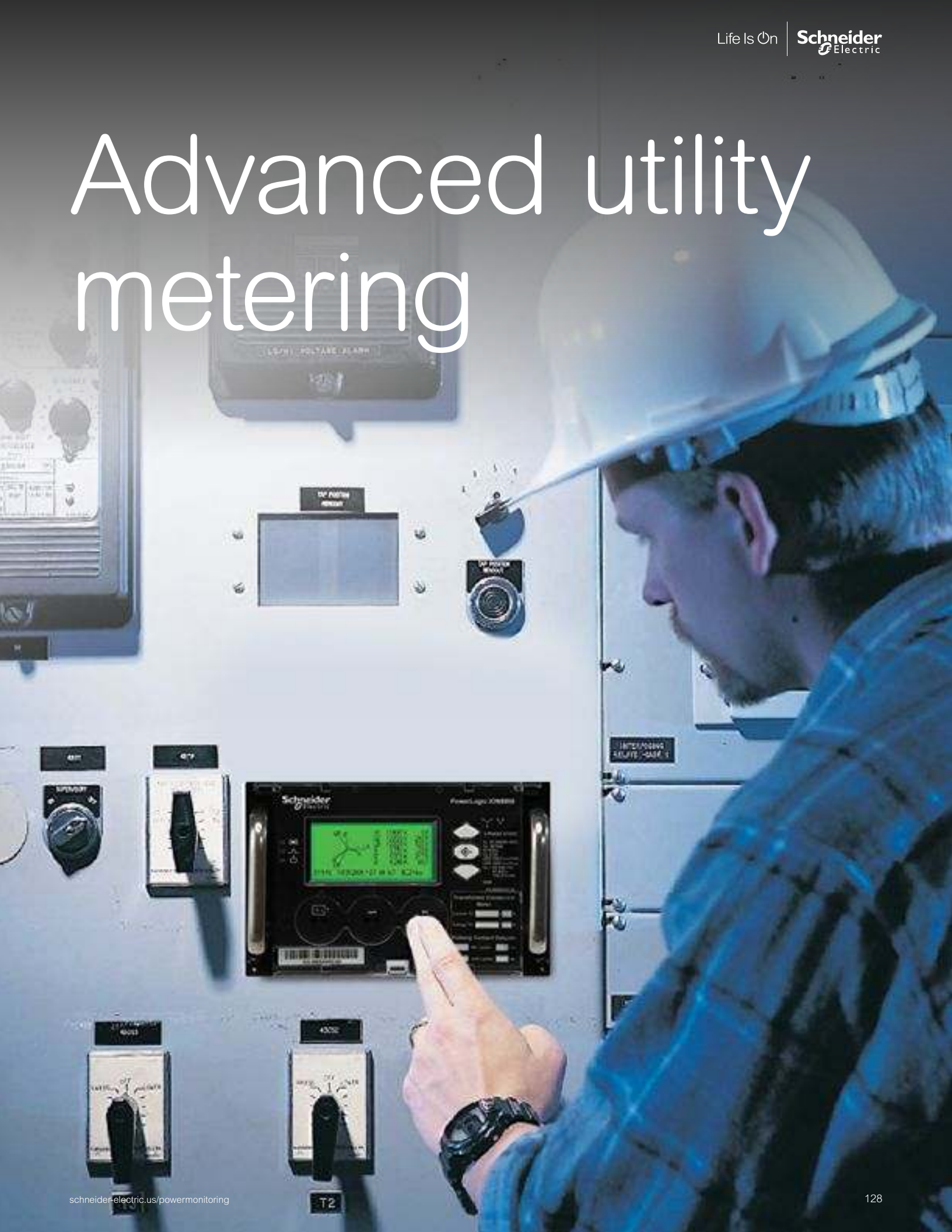

# Applications

Our power quality and revenue meters are designed to monitor utility networks such as transmission and distribution networks.

# Product overview

## Advanced utility metering

Our revenue and power quality meters are designed for precision metering at key transmission network inter-ties, distribution substations, and service entrances to optimise power reliability and energy efficiency in utility smart grids.

- PowerLogic ION8650
- PowerLogic ION7400

ADVANCED UTILITY METERING



# ION7400 utility feeder meter

The PowerLogic ION7400 utility feeder meter is a highly accurate, extremely reliable power and energy meter with unmatched flexibility and usability. The meter combines accurate 3-phase energy and power measurements with data logging, power quality analysis, alarming, and I/O capabilities not typically available in such a compact meter.

The panel or DIN mounted ION7400 meter is flexible enough to fit into a utility's existing billing or SCADA system, and provides industry-leading cost management (Class 0.2) and network management (Class S PQ) data. It is compliant with stringent international standards that guarantee metering accuracy and power quality measurements, and is ideal for installations that are responsible for maintaining the operation and profitability of a facility.

## Applications

- Revenue metering
- Extensive power quality monitoring and analysis
- Power quality compliance monitoring

PB115152



PowerLogic ION7400 meter showing active alarms

ION7400Rear



PowerLogic ION7400 meter—rear view

ION7400\_DIN\_Rear



PowerLogic ION7403 DIN rail-mounted meter

## ADVANCED UTILITY METERING

### The solution for

All markets that can benefit from a solution that includes PowerLogic ION7400 series meters:

- Utility networks

---

### Benefits

- Reduce operations costs
- Improve power quality
- Improve continuity of service

---

### Competitive advantages

- Can be integrated into existing wholesale settlement system
- Uses Power Monitoring Expert software for data analysis, and shares operation data with SCADA systems through multiple communication channels and protocols
- Transformer and line-loss compensation
- Backed by a 10-year warranty

### Conformity of standards

- IEC 61557-12 PMD Sx K70 3000m 0.2
- Class 0.2S accuracy IEC 62053-22, ANSI C12.20 Class 0.2
- IEC 61000-4-30 Class S
- IEC 61000-4-15 Flicker
- IEC 62586
- EN 50160
- IEC 61326-1
- IEC 62052-11
- CLC/TR50579

## Main characteristics

- Precision metering:
  - IEC 61557-12 PMD Sx K70 3000m 0.2 (performance measuring and monitoring functions)
  - Class 0.2S accuracy IEC 62053-22, ANSI C12.20, and Class 0.2 (active energy)
  - Industry-leading Class 0.5S accuracy for reactive energy (IEC 62053-24)
  - Cycle-by-cycle RMS measurements updated every 1/2 cycle
  - Full multi-utility WAGES metering support
  - Net metering
  - Anti-tamper protection seals
  - Test mode
- PQ-compliance reporting and basic PQ analysis
- Monitors and logs parameters in support of international PQ standards:
  - IEC 61000-4-30 Class S, IEC 61000-4-15 Flicker, IEC 62586, EN50160:2010, and IEEE 519:2014
- Generates onboard PQ-compliance reports accessible via onboard web pages:
  - Basic event summary and pass/fail reports, such as EN 50160 for power frequency, supply voltage magnitude, supply voltage dips, short and long interruptions, temporary over voltages, voltage unbalance, and harmonic voltage
  - ITIC (CBEMA) and SEMI curves, with alarm categorization to support further analyses
- Harmonic analysis:
  - THD on voltage and current, per phase, min/max, and custom alarming
  - Individual harmonic magnitudes and angles on voltage and current, up to the 63rd harmonic
- High-resolution waveform capture:
  - Triggered manually or by alarm, captured waveforms available directly from the meter via FTP in a COMTRADE format
- Disturbance detection and capture:
  - Sag and swell on any current and voltage channel, alarm on disturbance event, waveform capture with pre-event information
- Patented disturbance direction detection:
  - Provides indication of the captured disturbance occurring upstream or downstream of the meter; timestamped results provided in the event log, with degree of certainty of disturbance direction
- Used with EcoStruxure Power Monitoring Expert software, provides detailed PQ reporting across entire network:
  - EN 50160 report
  - IEC 61000-4-30 report
  - PQ compliance summary
  - ISO 50001
  - Display of waveforms and PQ data from all connected meters

# ION7400 utility feeder meter

## Functions and characteristics (cont.)

PB115153



PowerLogic ION7400 with Harmonics display

### Onboard data and event logging

- 512 MB of standard non-volatile memory; 10 MB of standard non-volatile memory dedicated to capturing billing data, events, and waveforms
- No data gaps due to network outages or server downtime
- Min/max log for standard values
- 50 user-definable data logs, recording up to 16 parameters on a cycle-by-cycle basis, or other user-definable intervals
- Continuous logging or 'snapshot' triggered by setpoint and stopped after defined duration
- Trend energy, demand, and other measured parameters
- Forecasting via web pages: average, minimum, and maximum for the next four hours and next four days
- Time-of-use in conjunction with EcoStruxure software
- Event log: alarm conditions, metering configuration changes, and power outages, timestamped to one millisecond

ION7400\_Remote\_Display



PowerLogic remote display

### Alarming and control

- 50+ definable alarms to log critical event data, trigger waveform recording, or perform control function
- Trigger on any condition, with cycle-by-cycle and 1-second response time
- Combine alarms using Boolean logic and create alarm levels
- Alarm notification via email text message
- In conjunction with EcoStruxure Power Monitoring Expert, software alarms and alarm frequency are categorized and trended for easy evaluation of worsening or improving conditions

PB113671



PowerLogic I/O module

### Excellent quality: ISO 9001 and ISO 14000 certified manufacturing

### Easy installation and setup

- Panel and DIN rail-mounting options, remote display option
- Pluggable connectors
- Free setup application simplifies meter configuration

### Front panel

- Easy-to-read color-graphic display
- Simple, intuitive menu navigation with multi-language (8) support
- Optical port
- Two energy-pulsing LEDs
- Alt and Norm screens



# ION7400 utility feeder meter

## Functions and characteristics (cont.)



PowerLogic ION7400 series meter with phasor display

Commercial reference numbers	
Meter description	Commercial ref. no.
ION7400 panel mount meter (integrated display with optical port and two energy-pulse LEDs)	METSEION7400
DIN rail mount — utility meter base	METSEION7403
Accessories description	
Accessories description	Commercial ref. no.
Remote display, 3-meter cable, mounting hardware for 1.18 in (30 mm) hole (nut and centering pin), mounting hardware for DIN96 cutout (3.78 x 3.78 in [96 x 96 mm]) adapter plate	METSEPM89RD96
Digital I/O module (six digital inputs and two relay outputs)	METSEPM89M2600
Analog I/O module (four analog inputs and two analog outputs)	METSEPM89M0024
Display cable, 10 meter	METSECAB10
Sealing kit	METSEPM8000SK

### Flexible remote communications

- Multiple simultaneously operating communication ports and protocols allow interfacing with other automation systems; (e.g., waveforms, alarms, billing data, etc.) can be uploaded for viewing/analysis while other systems access real-time information
- Supports Modbus, ION, DNP3 and IEC 61850
- Dual-port Ethernet: 10/100BASE-TX; daisy-chaining capability removes need for additional switches
- Create redundant network loop using rapid spanning tree protocol (RSTP) and managed Ethernet switches
- Customize TCP/IP port numbers enable or disable individual ports
- RS-485 two-wire connection, up to 115200 baud, Modbus RTU and ION protocols; DNP3 is also supported via RS-485
- Ethernet to serial gateway with Modbus Master functionality, connecting to 31 downstream serial Modbus devices. Also supports Modbus mastering over TCP/IP (Ethernet) network
- Full-function web server with factory and customizable pages to access real-time and PQ-compliance data
- Push historical data via email
- Advanced security: up to 16 configurable user accounts

### Time synchronization via:

- GPS clock (RS-485) or IRIG-B (digital input) to +/- 1 millisecond
- Also supports network time protocol (NTP/SNTP), Precision time protocol (PTP), and timeset function from EcoStruxure software server
- ION™ frameworks allow customizable, scalable applications and object-oriented programming, and also compartmentalizes functions and increases flexibility and adaptability
- Applications allow users to access and aggregate data from Modbus devices on a serial port or across the network (Modbus TCP/IP); log and process data by totalizing, unit conversion, or other calculations; apply complex logic for alarming or control operations; and allows data visualization via web pages

### Standard meter I/O

- Three digital status/counter inputs
- One KY (Form A) energy-pulse output for interfacing with other systems

### Modular I/O options

- Optional expansion modules (up to four per meter) add digital/analog I/O

### Optional modules include:

#### Digital module

- Six digital status/counter inputs
- Two form C relay outputs, 250 V, 8 A

#### Analog module

- Four analog inputs (4-20mA, 0-1mA, 0-20mA; 0-30V)
- Two analog outputs (4-20mA, 0-1mA, 0-20mA; 0-10V) for interfacing with building management sensors and systems

### Languages supported

English, French, Spanish, Chinese, Italian, German, Russian, Portuguese

# ION7400 utility feeder meter

## Functions and characteristics (cont.)

PB113696



PowerLogic™ ION7400 bottom view DIN mounting

Features		ION7400
<b>General</b>		
Use on LV and MV systems		■
Current accuracy (5 A Nominal)		0.1 % reading
Voltage accuracy (90-690 V AC L-L, 50, 60, 400 Hz)		0.1 % reading
Active energy accuracy		0.2 %
Number of samples per cycle or sample frequency		256
<b>Instantaneous RMS values</b>		
Current, voltage, and frequency		■
Active, reactive, and apparent power	Total and per phase	■
Power factor	Total and per phase	■
Current measurement range (autoranging)		0.05 A - 10 A
<b>Energy values</b>		
Active, reactive, and apparent energy		■
Settable accumulation modes		■
<b>Demand values</b>		
Current	Present and max values	■
Active, reactive, and apparent power	Present and max values	■
Predicted active, reactive, and apparent power		■
Synchronization of the measurement window		■
Setting of calculation mode	Block, sliding	■
<b>Power quality measurements</b>		
Harmonic distortion	Current and voltage	■
Individual harmonics	Via front panel and web page	31
	Via EcoStruxure software	63
Waveform capture		■
Detection of voltage swells and sags		■
Flicker		■
Fast acquisition	1/2 cycle data	■
EN 50160 compliance checking		■
Customizable data outputs (using logic and math functions)		■
<b>Data recording</b>		
Min/max of instantaneous values		■
Data logs		■
Event logs		■
Trending/forecasting		■
SER (sequence of event recording)		■
Timestamping		■
GPS synchronization (+/- 1 ms)		■
Memory (in MB)		512 (10 MB for frameworks)
<b>Display and I/O</b>		
Front-panel display 3.50 in (89 mm) TFT		■
Wiring self-test		■
Pulse output		1
Digital		6 In/2 Out
Analog		4 In/2 Out
Digital or analog outputs (max, including pulse output)		1 digital 8 relay 8 analog
<b>Communication</b>		
RS-485 port		1
10/100BASE-TX		2
Serial port (Modbus, ION, DNP3)		■
Ethernet port (Modbus/TCP, ION TCP, DNP3 TCP, IEC 61850)		■
USB port (mini type B)		■
ANSI C12.19 optical port		■

All communications ports may be used simultaneously.

# ION7400 utility feeder meter

## Functions and characteristics (cont.)

ION7400 meter parts descriptions

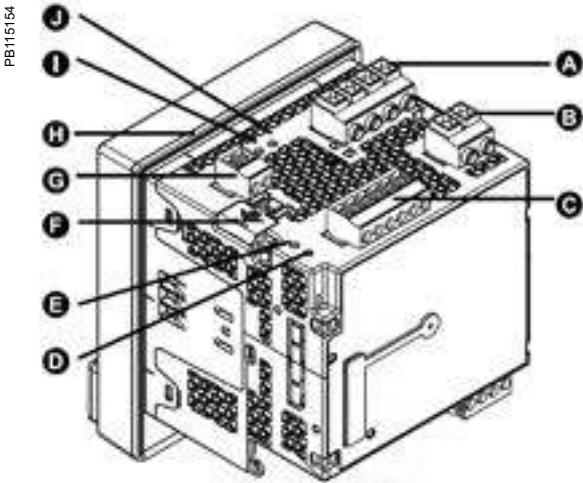

- A Voltage inputs
- B Control power
- C Digital inputs
- D Revenue lock LED
- E Status LED (2)
- F Revenue lock switch
- G Digital output
- H Sealing gasket
- I Infrared energy-pulsing LED
- J Energy-pulsing LED

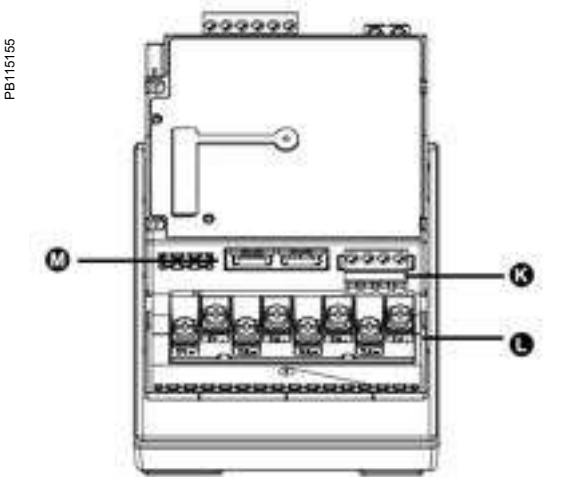

- K RS-485
  - L Current inputs
  - M Ethernet (2)
  - N Date/time
  - O Indicator icons
- NORM / ALT Mode Alarm Revenue

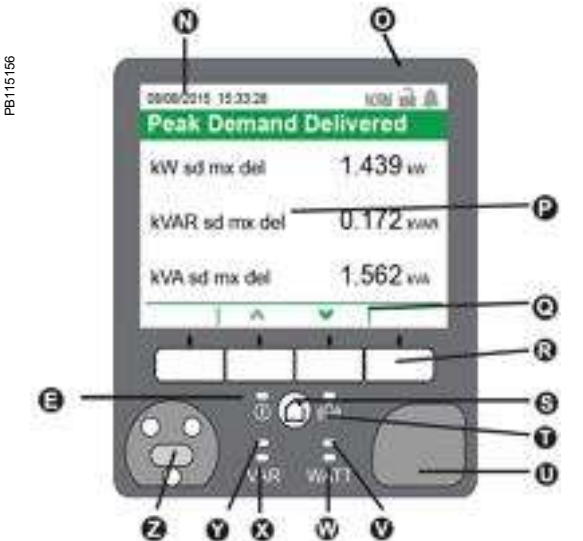

- P Display
- Q Navigation icons
- Select Cancel Edit More
- R Navigation buttons
- S Home button
- T Alarm LED
- U USB ports cover
- V Watt energy-pulsing LED
- W Watt infrared energy-pulsing LED
- X VAR infrared energy-pulsing LED
- Y VAR energy-pulsing LED
- Z Optical port

# ION7400 utility feeder meter

## Functions and characteristics (cont.)

Technical specifications		ION7400
Type of measurement		True RMS to 256 samples per cycle
Measurement accuracy	Current and voltage	Class 0.2 as per IEC 61557-12
	Active power	Class 0.2 as per IEC 61557-12
	Power factor	Class 0.5 as per IEC 61557-12
	Frequency	Class 0.2 as per IEC 61557-12
	Active energy	Class 0.2S IEC 62053-22 (In = 5A) Class 0.2 IEC 61557-12, ANSI C12.20 Class 0.2
	Reactive energy	Class 0.5S IEC 62053-24
Data update rate		1/2 cycle or 1 second
Input-voltage characteristics	Specified accuracy voltage	57 V L-N/100 V L-L to 400 V L-N/690 V L-L
	Impedance	5 MΩ per phase
	Specified accuracy frequency - frequency	42 to 69 Hz (50/60 Hz nominal)
	Limit range of operation - frequency	20 Hz to 450 Hz
Input-current characteristics	Rated nominal current	1 A (0.2S), 5 A (0.2S), 10 A (0.2 ANSI)
	Specified accuracy current range	Starting current: 5 mA Accurate range: 50 mA – 10 A
	Permissible overload	200 A RMS for 0.5s, non-recurring
	Impedance	0.0003 Ω per phase
	Burden	0.024 VA at 10 A
	Power supply	AC
DC		120-300 V DC ±10%
Ride-through time		100 ms (6 cycles at 60 Hz) min, any condition 200 ms (12 cycles at 60 Hz) typ., 120 V AC 500 ms (30 cycles at 60 Hz) typ., 415 V AC
Burden		Meter only: 18 VA max at 415 V AC, 6W at 300 V DC Fully optioned meter: 36 VA max at 415 V AC, 17 W at 300 V DC
Input/outputs	Meter base only	3 Form A digital inputs (30 V AC/60 V DC) 1 Form A (KY) solid state digital output (30 V AC/60 V DC, 75 mA)
	Optional	Digital – 6 Form A digital inputs (30 V AC/60 V DC) wetted + 2 Form C relay outputs (250 V AC/30 V DC, 8 A at 250 V AC or 5 A at 24 V DC) Analog – 4 analog inputs (4-20mA, 0-30 V DC) + 2 analog outputs (4-20 mA, 0-10 V DC)
Mechanical characteristics		
Weight		Integrated display model 1.56 lb (0.706 kg) DIN rail-mounted model 1.16 lb (0.528 kg) IO modules 0.31 lb (0.140 kg) Remote display 0.66 lb (0.300 kg)
IP degree of protection		IP 54, UL type 12: panel mount and remote display, front IP 30: panel mount rear, DIN rail mount, I/O modules
Dimensions	Panel mount model	3.86 x 4.41 x 3.09 in (98 x 112 x 78.5 mm)
	DIN model	3.56 x 3.56 x 3.57 in (90.5 x 90.5 x 90.8 mm)
	Remote display	3.78 x 3.78 x 1.06 in (96 x 96 x 27 mm)
	IO modules	3.56 x 3.56 x 0.87 in (90.5 x 90.5 x 22 mm)
Environmental conditions		
Operating temperature		-25 °C to 70 °C
Remote display unit		-25 °C to 60 °C
Storage temperature		-40 °C to 85 °C
Humidity rating		5% to 95% non-condensing
Installation category		III
Operating altitude (maximum)		3000 m above sea level

# ION7400 utility feeder meter

## Functions and characteristics (cont.)

Electromagnetic compatibility	
Product standards	IEC 62052-11 and IEC 61326-1
Immunity to electrostatic discharge	IEC 61000-4-2
Immunity to radiated fields	IEC 61000-4-3
Immunity to fast transients	IEC 61000-4-4
Immunity to surges	IEC 61000-4-5
Immunity to conducted disturbances	IEC 61000-4-6
Immunity to power frequency magnetic fields	IEC 61000-4-8
Immunity to conducted disturbances, 2-150kHz	CLC/TR 50579
Immunity to voltage dips and interruptions	IEC 61000-4-11
Immunity to ring waves	IEC 61000-4-12
Conducted and radiated emissions	EN 55022, EN 55011, FCC part 15, ICES-003
Surge withstand capability (SWC)	IEEE C37.90.1
Safety	
Safety construction	IEC/EN 61010-1 ed.3, CAT III, 400 V L-N/690 V L-L UL 61010-1 ed.3 and CSA-C22.2 No. 61010-1 ed.3, CAT III, 347 V L-N/600 V L-L IEC/EN 62052-11, protective class II
Communication	
Ethernet to serial line gateway	Communicates directly with up to 32 unit load ION slave devices
Web server	Customizable pages, new page creation capabilities, HTML/XML compatible
Serial port RS 485	Baud rates of 2400 to 115200, pluggable screw terminal connector
Ethernet port(s)	2 x 10/100BASE-TX, RJ45 connector (UTP)
USB port	Virtual serial port supports USB 3.0, 2.0, 1.1 using ION protocol
Protocol	Modbus, ION, DNP3, IEC 61850, HTTPS, FTP, SNMP, SMTP, DPWS, RSTP, NTP, SNTP, and GPS protocols
Firmware characteristics	
High-speed data recording	Down to 1/2-cycle interval-burst recording, stores detailed characteristics of disturbances or outages; trigger recording by a user-defined setpoint or from external equipment
Harmonic distortion	Up to 63rd harmonic (127th via EcoStruxure software) for all voltage and current inputs
Sag and swell detection	Analyze severity/potential impact of sags and swells: magnitude and duration data suitable for plotting on voltage tolerance curves per phase triggers for waveform recording, control
Disturbance direction detection	Determine the location of a disturbance more quickly and accurately by determining the direction of the disturbance relative to the meter; analysis results are captured in the event log, along with a timestamp and confidence level indicating level of certainty
Instantaneous	High accuracy of standard speed (1s) and high-speed (1/2-cycle) measurements, including true RMS per phase and total for voltage, current, active power (kW), reactive power (kvar), apparent power (kVA), power factor, frequency, voltage and current unbalance, and phase reversal
Load profiling	Channel assignments (800 channels via 50 data recorders) configurable for any measurable parameter, including historical trend recording of energy, demand, voltage, current, power quality, or any measured parameter; trigger recorders based on time interval, calendar schedule, alarm/event condition, or can be set manually
Trend curves	Historical trends and future forecasts to better manage demand, circuit loading, and other parameters; provides average, min, max, and standard deviation every hour for last 24 hours, every day for last month, every week for last 8 weeks, and every month for last 12 months
Waveform captures	Ability to record from 210 cycles at 256 samples per cycle to over 2880 cycles at 16 samples per cycle with user selectable sampling rate as well as pre- and post-trigger lengths
Alarms	Threshold alarms have adjustable pickup and dropout setpoints and time delays; numerous activation levels possible for a given type of alarm; user-defined or automatic alarm threshold settings; user-defined priority levels (optional automatic alarm setting)

All communication ports may be used simultaneously.

ADVANCED UTILITY METERING

# ION7400 utility feeder meter

## Functions and characteristics (cont.)

### ION7400 meter dimensions

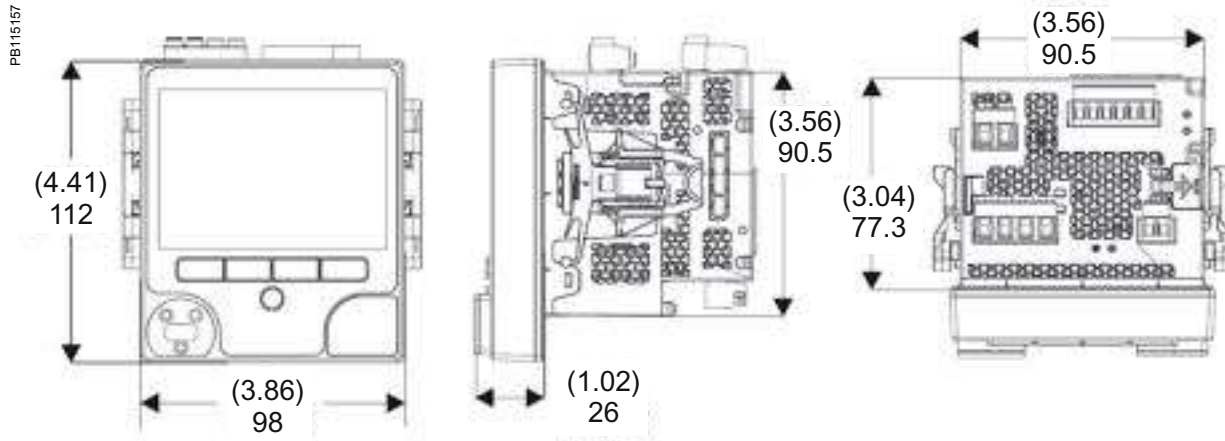

### ION7400 panel cutout dimensions

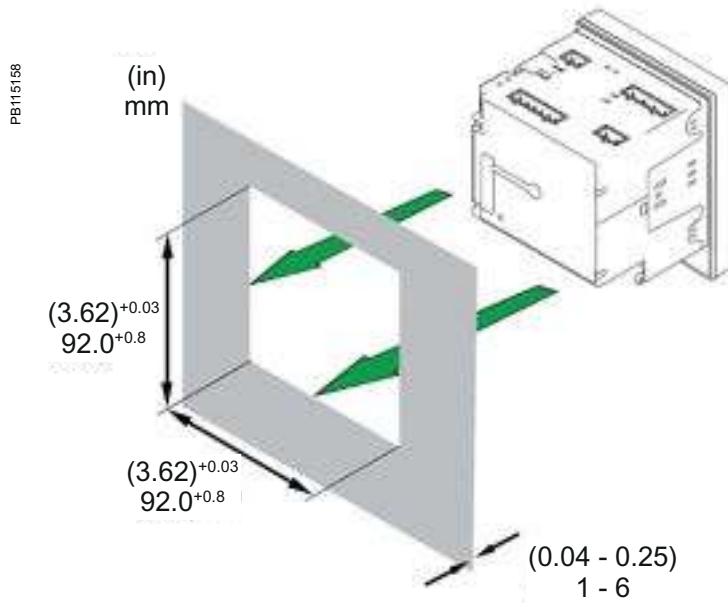

For further details, please see appropriate Schneider Electric Installation Guide for this product.

ADVANCED UTILITY METERING

# ION8650

Used to monitor electric energy provider networks, service entrances, and substations, PowerLogic ION8650 meters are ideal for independent power producers, as well as cogeneration applications that need to accurately measure energy bi-directionally in both generation and stand-by modes.

These meters give utilities the tools to manage complex energy supply contracts that include commitments to power quality. Integrate them with our EcoStruxure Power Monitoring (ION Enterprise™) operations software, or with other energy management and SCADA systems through multiple communication channels and protocols, including Itron MV-90, Modbus, DNP, DLMS, and IEC 61850 Ed. 2.

## Applications

- Revenue metering
- Co-generation and IPP monitoring
- Compliance monitoring
- Power quality analysis
- Demand and power factor control
- Load curtailment
- Equipment monitoring and control
- Energy pulsing and totalization
- Instrument transformer correction
- Key customer PCC metering/PQ monitoring
- Microgrids and renewables (solar, wind, DER)
- Intelligent SCADA node
- Transmission and distribution system metering
- Grid intertie metering
- Customized engineering

PB107500



PowerLogic ION8650 socket meter

## ADVANCED UTILITY METERING

### The solution for

Markets that can benefit from a solution that includes PowerLogic ION8650 series meters:

- Utility networks
- 

### Benefits

- Reduce operational costs
- Improve power quality
- Improve electrical network reliability
- Provide class-leading ANSI revenue metering accuracy
- Manage complex metering requirements easily
- Seamlessly integrate with multiple systems

### Competitive advantages

- Integrates with Power Monitoring Expert software for data analysis or to share operation data with SCADA systems through multiple communication channels and protocols
  - Transformer/line-loss compensation
  - Backed by a 10-year warranty
- 

### Conformity of standards

- Class 0.2S accuracy IEC 62053-22, ANSI C12.20 Class 0.2
- IEC 61000-4-30 Class S
- IEC 61000-4-7
- IEC 61000-4-15 Flicker
- IEEE 1159
- IEEE 519
- IEC 61850 Ed. 2

# ION8650

## Functions and characteristics (cont.)

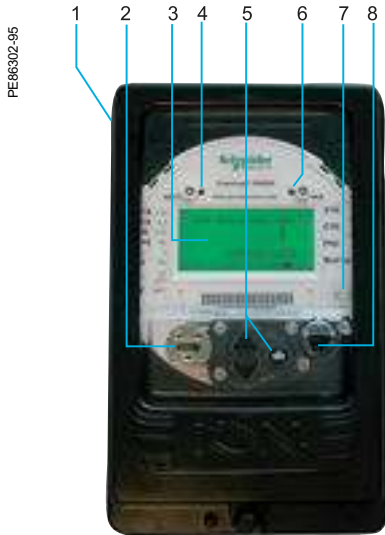

PowerLogic ION8650 switchboard meter

- 1 Terminals**
- 2 Optical port**
- 3 Main display status bar**
- 4 Watt LED**
- 5 Navigation, ALTIEnter buttons**
- 6 VAR LED**
- 7 Nameplate label**
- 8 Demand reset switch**

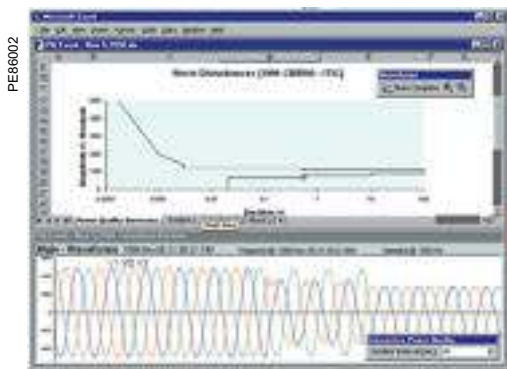

Disturbance waveform capture and power quality report

### Commercial reference numbers

ION8650 meters	Commercial ref. no.
ION8650A	S8650A
ION8650B	S8650B
ION8650C	S8650C

### Main characteristics

- ANSI Class 0.2 and IEC 62053-22/23 Class 0.2 S metering
  - For interconnection points on medium, high, and ultra-high voltage networks; twice as accurate as current IEC and ANSI Class 0.2 standards over all conditions and including single, wide-range current measurement
- Power quality compliance monitoring
  - Monitor compliance with international quality-of-supply standards (IEC 61000-4-30 Class A/S, EN 50160 Ed. 4, IEC 61000-4-7, IEC 61000-4-15, IEEE 1159, IEEE 519); also detects disturbance direction
- Digital fault recording
  - Simultaneous capture of voltage and current channels for sub-cycle disturbance
- Complete communications
  - Multi-port; multi-protocol ports including serial, infrared, modem, and Ethernet; simultaneously supports multiple industry standard protocols including Itron MV-90, Modbus, Modbus Master, DLMS, DNP 3.0, and IEC 61850 Ed. 2
- Multiple tariffs and time-of-use
  - Apply tariffs and seasonal rate schedules to measure energy and demand values for time periods with specific billing requirements
- Multiple setpoints for alarm and functions
  - Use up to 65 setpoints for single/multi-condition alarms and I/O functions with response times down to a 1/2 cycle
- Instrument transformer correction
  - Save money and improve accuracy by correcting for less accurate transformers
- Alarm notification via email
  - High-priority alarms and data logs can be sent directly to the user's PC, providing instant notification of power quality events by email
- Cybersecurity enhancements
  - Assign communication admin rights to selected user, prevention measures ensure no loss of security logs, and support syslog for external security

# ION8650

## Functions and characteristics (cont.)

Selection guide	ION8650 A	ION8650 B	ION8650 C
<b>General</b>			
Use on LV, MV, and HV systems	■	■	■
Current accuracy	0.1 %	0.1 %	0.1 %
Voltage accuracy	0.1 %	0.1 %	0.1 %
Power accuracy	0.1 %	0.1 %	0.1 %
Samples per cycle	1024	1024	1024
<b>Instantaneous values</b>			
Current, voltage, and frequency	■	■	■
Active, reactive, and apparent power	Total and per phase	■	■
Power factor	Total and per phase	■	■
Current measurement range	0 A- 20 A	0 A- 20 A	0 A- 20 A
<b>Energy values</b>			
Active, reactive, and apparent energy	■	■	■
Settable accumulation modes	■	■	■
<b>Demand values</b>			
Current	Present and max values	■	■
Active, reactive, and apparent power	Present and max values	■	■
Predicted active, reactive, and apparent power		■	■
Synchronization of the measurement window		■	■
Demand modes: block (sliding), thermal (exponential)		■	■
<b>Power quality measurements</b>			
Harmonic distortion	Current and voltage	■	■
Individual harmonics	Via front panel	63	63
Waveform/transient capture		■ / ■	- / -
Harmonics: magnitude, phase, and interharmonics		50	40
Detection of voltage sags and swells		■	■
IEC 61000-4-30 class A /S		↑	↗
IEC 61000-4-15 (flicker)		■	■
High-speed data recording (down to 10 ms)		■	■
EN 50160-compliance reporting		■	■
Programmable (logic and math functions)		■	■
<b>Data recording</b>			
Onboard memory (in MB)	128	64	32
Revenue logs	■	■	■
Event logs	■	■	■
Historical logs	■	■	■
Harmonics logs	■	■	■
Sag and swell logs	■	■	■
Transient logs	■	-	-
Timestamping to 1 ms	■	■	■
GPS synchronization (IRIG-B standard)	■	■	■
<b>Display and I/O</b>			
Front-panel display	■	■	■
Wiring self-test (requires PowerLogic ION setup)	■	■	■
Pulse output (front panel LED)	2	2	2
Digital or analog inputs* (max)	11	11	11
Digital or analog outputs* (max, including pulse output)	16	16	16
<b>Communication</b>			
Infrared port	1	1	1
RS-485/RS-232 port	1	1	1**
RS-485 port	1	1	1**
Ethernet port (Modbus/TCP/IP protocol) with gateway	1	1	1**
Internal modem with gateway (ModemGate)	1	1	1**
HTML web page server	■	■	■
IRIG-B port (unmodulated IRIG B00x time format)	1	1	1
Modbus TCP master/slave (Ethernet port)	■ / ■	■ / ■	- / ■
Modbus RTU master/slave (serial ports)	■ / ■	■ / ■	- / ■
DNP 3.0 through serial, modem, and I/R ports	■	■	■

\* With optional I/O Expander

\*\* C model limited to IR + 2 other ports at one time; ports can be enabled/disabled by user

# ION8650

## Functions and characteristics (cont.)

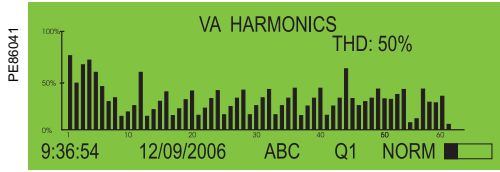

PowerLogic ION8650 front panel harmonic display

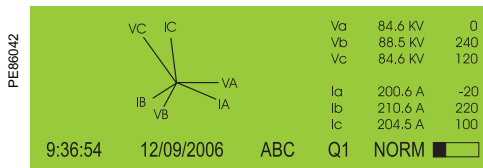

ION8650 front panel phasor display and table

Technical characteristics		
Type of measurement		True RMS 1024 samples per cycle
Measurement accuracy	Current and voltage	0.1 % reading
	Power	0.1 %
	Frequency	±0.001 Hz
	Power factor	0.1 %
	Energy	0.1 %, twice as accurate as ANSI Class 0.2 and IEC 62053-22/23 (0,2S)
Data update rate		0.5 cycle or 1 second (depending on value)
Input-voltage characteristics*	Nominal voltage	57 V to 277 V L-N RMS 100 V to 480 V L-L RMS (35S)
	Maximum voltage	347 V L-N RMS, 600 V L-L RMS (9S)
	Impedance	5 MΩ/phase (phase-Vref/Ground)
	Inputs	V1, V2, V3, VREF
Input-current characteristics	Rated nominal current class	1A, 2 A, 5 A and/or 10 A (Class 1/2/10/20)
	Accuracy range	0.01 – 20 A (standard range)
	Measurement range	0.001 – 24 A
	Permissible overload	500 A RMS for 1 second, non-recurring
	Burden per phase	Socket: typical: 3 W, 8 VA/phase, 3-phase operation Maximum: 4 W, 11 VA/phase, 3-phase operation Switchboard: 0.05 V A at 1 A (0.05 Ω max)
	Power supply	Standard power supply, blade powered
Auxiliary powered low voltage		AC: 65-120 (+/- 15 %) VLN RMS, 47-63 Hz DC: 80-160 (+/- 20 %) VDC
Auxiliary powered high voltage		AC: 160-277 (+/- 20 %) V L-N RMS, 47-63 Hz DC: 200-300 (+/- 20 %) V DC
Ride-through time, (standard power supply)		Socket: min guaranteed: 6 cycles at nominal frequency (minimum 50 Hz), at 120 V L-N RMS (208 V L-L RMS) 3-phase operation Switchboard: min guaranteed: 6 cycles at nominal frequency (minimum 50 Hz), at 120 V L-N RMS (208 V L-L RMS) 3-phase operation
Input/outputs**		Digital outputs
	Digital inputs	Up to 3 self-excited, dry contact-sensing inputs
Mechanical characteristics		
Weight		15.43 lb (7.0 kg)
IP degree of protection	Socket	Front IP65, back IP51
	Switchboard	Front IP50, back IP30
Dimensions	Socket	7 x 9.33 in (178 x 237 mm)
	Switchboard	11.22 x 8.98 x 6.42 in (285 x 228 x 163 mm)
Environmental conditions		
Operating temperature		-40 °C to 85 °C
Display operating range		-40 °C to 70 °C
Storage temperature		-40 °C to 85 °C
Humidity rating		5 % to 95 % RH non-condensing
Pollution degree		2
Installation category		Cat III
Dielectric withstand		2.5 kV
Electromagnetic compatibility		
Electrostatic discharge		IEC 61000-4-2
Immunity to radiated fields		IEC 61000-4-3
Immunity to fast transients		IEC 61000-4-4
Immunity to surge		IEC 61000-4-5
Immunity conducted		IEC 61000-4-6
Damped oscillatory waves immunity		IEC 61000-4-12
Conducted and radiated emissions		CISPR 22 (Class B)
Safety		
Europe		As per IEC 62052-11
North America		As per ANSI C12.1

\* Specifications are limited by the operating range of the power supply if a non-aux power supply is used

\*\* More input and output selections available via optional I/O expander

# ION8650

## Functions and characteristics (cont.)



Example embedded web server page (WebMeter) showing real-time values

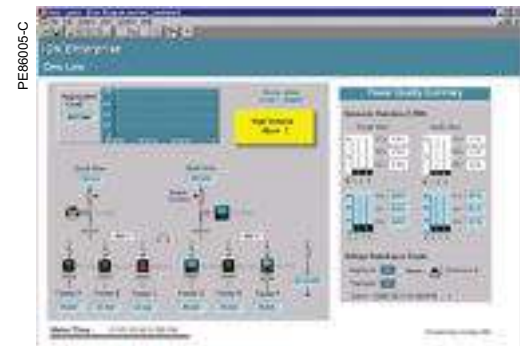

Communication	
RS-232 / RS-485 port (COM1)	User-selectable RS-232 or RS-485 300–115,200 bauds (RS-485 limited to 57,600 bps) Protocols: ION, Modbus/RTU/Mastering, DLMS, DNP 3.0, GPSTRUETIME/DATUM
Internal modem port (COM2)	300 – 57,600 bps
ANSI 12.18 Type II optical port (COM3)	Up to 57,600 bps
RS-485 port (COM4)	Up to 57,600 bauds, Modbus, direct connection to a PC or modem
Ethernet port	10/100BASE-T, RJ45 connector, protocols: DNP, ION, Modbus/TCP/Mastering, IEC 61850 Ed. 2 or 100BASE-FX multimode, male ST connectors
EtherGate	Up to 31 slave devices via serial ports
ModemGate	Up to 31 slave devices

Firmware characteristics	
High-speed data recording	Up to 1/2-cycle, interval-burst recording, stores detailed characteristics of disturbances or outages; trigger recording by a user-defined setpoint, or from external equipment
Harmonic distortion	Up to 63rd harmonic for all voltage and current inputs
Dip/swell detection	Analyze severity/potential impact of sags and swells: - magnitude and duration data suitable for plotting on voltage tolerance curves - per phase triggers for waveform recording or control operations
Instantaneous	High-accuracy measurements with 1s or 1/2 cycle update rate for: - voltage and current - active power (kW) and reactive power (kVAR) - apparent power (kVA) - power factor and frequency - voltage and current unbalance - phase reversal
Load profiling	Channel assignments are user configurable: - 800 channels via 50 data recorders (feature set A) - 720 channels via 45 data recorders (feature set B) - 80 channels via 5 data recorders (feature set C) Configure for historical trend recording of energy, demand, voltage, current, power quality, and other measured parameters; recorders can trigger on a time interval basis, calendar schedule, alarm/event condition, or can be set manually
Waveform captures	Simultaneous capture of all voltage and current channels - sub-cycle disturbance capture (16 to 1024 samples per cycle)
Alarms	Threshold alarms: - adjustable pickup and dropout setpoints and time delays, numerous activation levels possible for a given type of alarm - user-defined priority levels - Boolean combination of alarms
Advanced security	Up to 50 users with unique access rights; perform resets, time syncs, or meter configurations based on user privileges
Transformer correction	Correct for phase/magnitude inaccuracies in current transformers (CTs), potential transformers (PTs)
Memory	128 MB (A), 64 MB (B), 32 MB (C)
Firmware update	Update via the communication ports

Display characteristics	
Type	FSTN transreflective LCD
Backlight	LED
Languages	English

# ION8650

## Functions and characteristics (cont.)

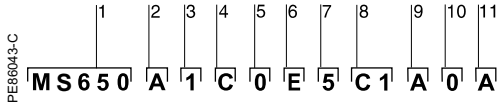

Example product part number

- 1 Model
- 2 Feature set
- 3 Form factor
- 4 Current inputs
- 5 Voltage inputs
- 6 Power supply
- 7 System frequency
- 8 Communications
- 9 Input/output options
- 10 Security
- 11 Special order options



PowerLogic ION8650 meter with switchboard case

### Commercial reference numbers

Item	Code	Description	
1 Model	S8650	Schneider Electric energy and power quality meter	
2 Feature set	A	128 MB Memory Class A power quality analysis, waveforms, and transient capture with 1024 samples per cycle	
	B	64 MB memory, energy meter Class S EN 50160 Ed. 4 power quality monitoring	
	C	32 MB memory, basic tariff/energy metering (5 data recorders, 80 channels)	
3 Form factor (1)	0	Form 9S/29S/36S base, 57-277 V L-N (autoranging) 3-element, 4-wire / 2 1/2-element, 4-wire	
	1	Form 35S base – 120-480 V L-L (autoranging) 2-element, 3-wire	
	4	Form 9/29/35/36S FT21 switchboard (meter + case) with breakout panel	
	7	Form 9/29/35/36S FT21 switchboard (meter + case) with breakout cable	
	4 Current inputs	C	1, 2, or 5 A nominal, 20 A full scale (24 A fault capture, start at 0.001 A)
5 Voltage inputs	0	Standard (see Form factor above)	
6 Power supply*	E	Form 9/29/35/36S, (socket) and Form 9, 36 (FT21 switchboard): 120-277 V AC. Form 35S (socket) and form 35 (FT21 switchboard): 120-480 V AC; powered from the meter's voltage connections	
	H	Auxiliary power pigtail: 65-120 V AC or 80-160 V DC (power from external source)	
	J	Auxiliary power pigtail: 160-277 V AC or 200-300 V DC (power from external source)	
	7 System frequency	5	Calibrated for 50 Hz systems
		6	Calibrated for 60 Hz systems
8 Communications	A 0	Infrared optical port, RS-232/RS-485 port, RS-485 port	
	C 7	Infrared optical port, Ethernet (10/100BASE-T), RS-232/485 port, RS-485 port (note: in addition to infrared optical port, Feature Set C can use any two ports [configurable]), 56 k universal internal modem (RJ11)	
	E 1	Infrared optical port, Ethernet (10/100BASE-T), RS 232/485 port, RS-485 port (note: in addition to infrared optical port, Feature Set C can use any two ports [configurable])	
	F 1	Infrared optical port, Ethernet (100BASE-FX multi-mode) with male ST connectors (available on socket meters only, forms 0 and 1 above; I/O card not available with this option) RS-232/485 port, RS-485 port (note: in addition to infrared optical port, Feature Set C can use any two ports [configurable])	
	M 1	Infrared optical port, RS-232/485 port, RS-485 port (note: in addition to infrared optical port, Feature Set C can use any two ports [configurable]), 56 k universal internal modem (RJ11)	
	S 0	Infrared optical port, Ethernet (10BASE-T), RS-232/485 port, RS-485 port (note: in addition to infrared optical port, Feature Set C can use any two ports [configurable]), Verizon cell modem**	
	S 1	Infrared optical port, Ethernet (10 BASE-T), RS-232/485 port, RS-485 port (note: in addition to infrared optical port, Feature Set C can use any two ports (configurable)), Verizon 4G LTE cell modem**	
	9 Onboard I/O	A	None
	B	4 Form C digital outputs, 3 Form A digital inputs	
	C	4 Form C digital outputs, 1 Form A digital output, 1 digital input	
	10 Security	1	Password protected, no security lock
2		Password protected with security lock enabled	
3		RMICAN (Measurement Canada approved)	
4		RMICAN-SEAL (Measurement Canada approved and factory sealed)	
7		Password protected, no security lock (U.S. only)	
	8	Password protected with security lock enabled (U.S. only)	
11 Special order	A	None	

\*Specifications are limited by the operating range of the power supply if a non-aux power supply is used

\*\*Communications options S0 and S1 are not available with Form Factor 4 or 7

# ION8650

## Functions and characteristics (cont.)

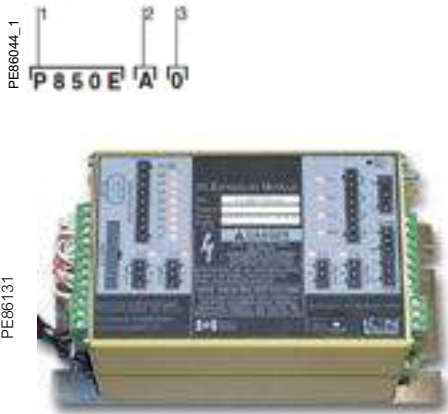

Example order code. Use this group of codes when ordering the I/O Expander.

- 1 Digital/Analog I/O
- 2 I/O option
- 3 Cable option

### Commercial reference numbers (cont.)

I/O Expander		
Digital/analog I/O	<b>P850E</b>	Schneider Electric I/O Expander for ION8600 meters: inputs and outputs for energy pulsing, control, energy counting, status monitoring, and analog interface to SCADA
I/O option	<b>A</b>	External I/O box with 8 digital inputs and 8 digital outputs (4 Form A, 4 Form C)
	<b>B</b>	External I/O box with 8 digital inputs and 4 digital outputs (4 Form C) and 4 analog outputs (0 to 20mA)
	<b>C</b>	External I/O box with 8 digital inputs and 4 digital outputs (4 Form C) and 4 analog outputs (-1mA to 1mA)
	<b>D</b>	External I/O box with 8 digital inputs and 4 digital outputs (4 Form C) and 4 analog outputs (two -1 to 1 mA, and two 0 to 20 mA outputs)
Cable option	<b>0</b>	No cable – cables for the I/O box are not ordered as a separate part number. Refer to commercial reference numbers: <b>CBL-8X00IOE5FT</b> , <b>CBL-8X00IOE15FT</b> and <b>CBL-8XX0-BOP-IOBOX</b> under Connector cables, below

A-BASE adapters	Comm. ref. no.
Form 9S to Form 9A adapter	<b>A-BASE-ADAPTER-9</b>
Form 35S to Form 35A adapter	<b>A-BASE-ADAPTER-35</b>
Optical communication interface	OPTICAL-PROBE
Optical communication interface	<b>OPTICAL-PROBE</b>
Connector cables	
1.5 m extension cable, mates with 24-pin male Molex connector from the meter to the 24-pin Molex connector on the I/O expander box (not for use with breakout panel E8, F8 & G8 form factors)	<b>CBL-8X00BRKOUT</b>
44.57 m extension cable, mates with 24-pin male Molex connector from the meter to the 24-pin Molex connector on the I/O expander box (not for use with breakout panel E8, F8 & G8 form factors)	<b>CBL-8X00IOE5FT</b>
44.57 m extension cable, mates with 24-pin male Molex connector from the meter to the 24-pin female Molex connector on the I/O expander box (not for use with breakout panel E8, F8 and G8 form factors)	<b>CBL-8X00IOE15FT</b>
1.8 m connector cable, 24-pin male to 14-pin male Molex connector for connecting an ION8000 series meter with breakout panel to an I/O expander box	<b>CBL-8XX0-BOP-IOBOX</b>

ADVANCED UTILITY METERING

# ION8650

## Functions and characteristics (cont.)

### ION8650 socket dimensions

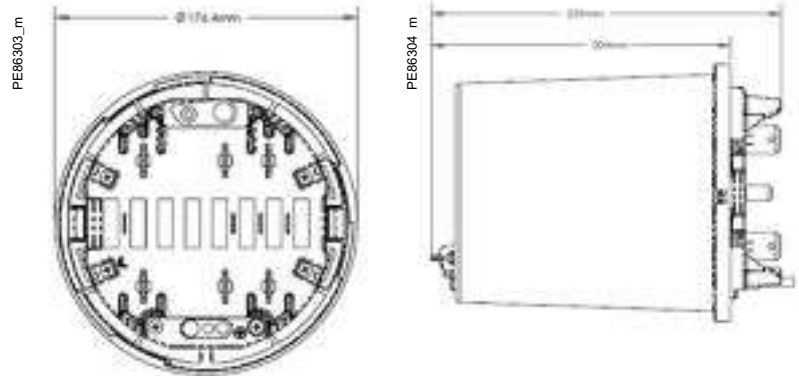

### ION8650 switchboard dimensions

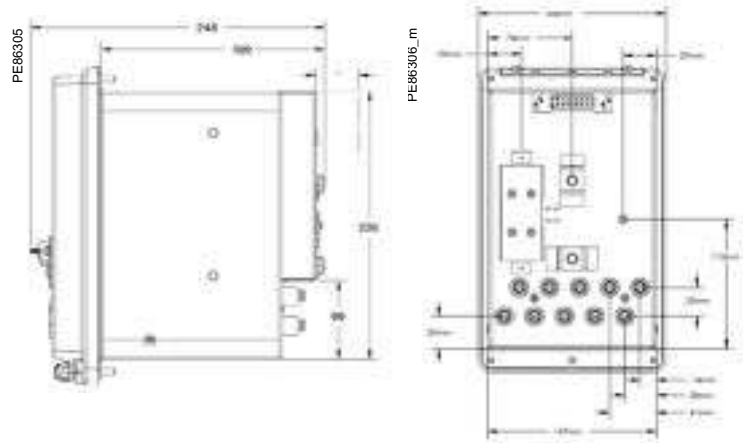

### I/O expander dimensions

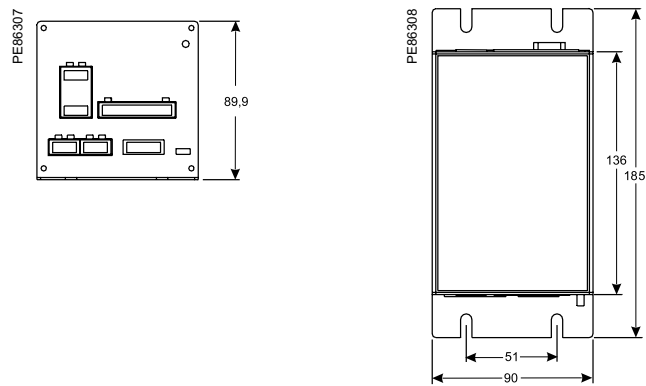

# ION8650

## Functions and characteristics (cont.)

### ION8650 suggested switchboard mounting dimensions

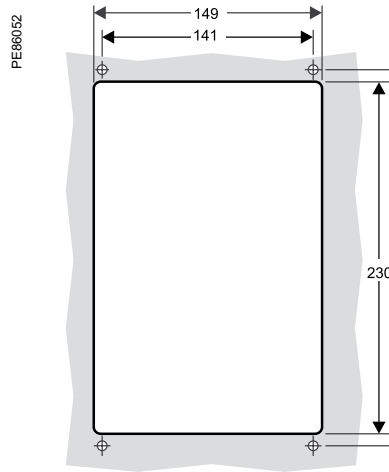

### ION8650 switchboard mounting

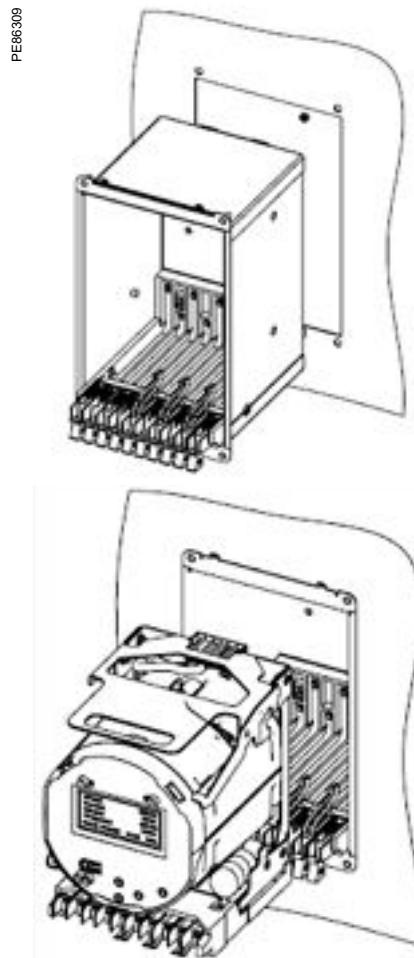

For further details, please see appropriate Schneider Electric Installation Guide for this product.

# Multi-circuit metering

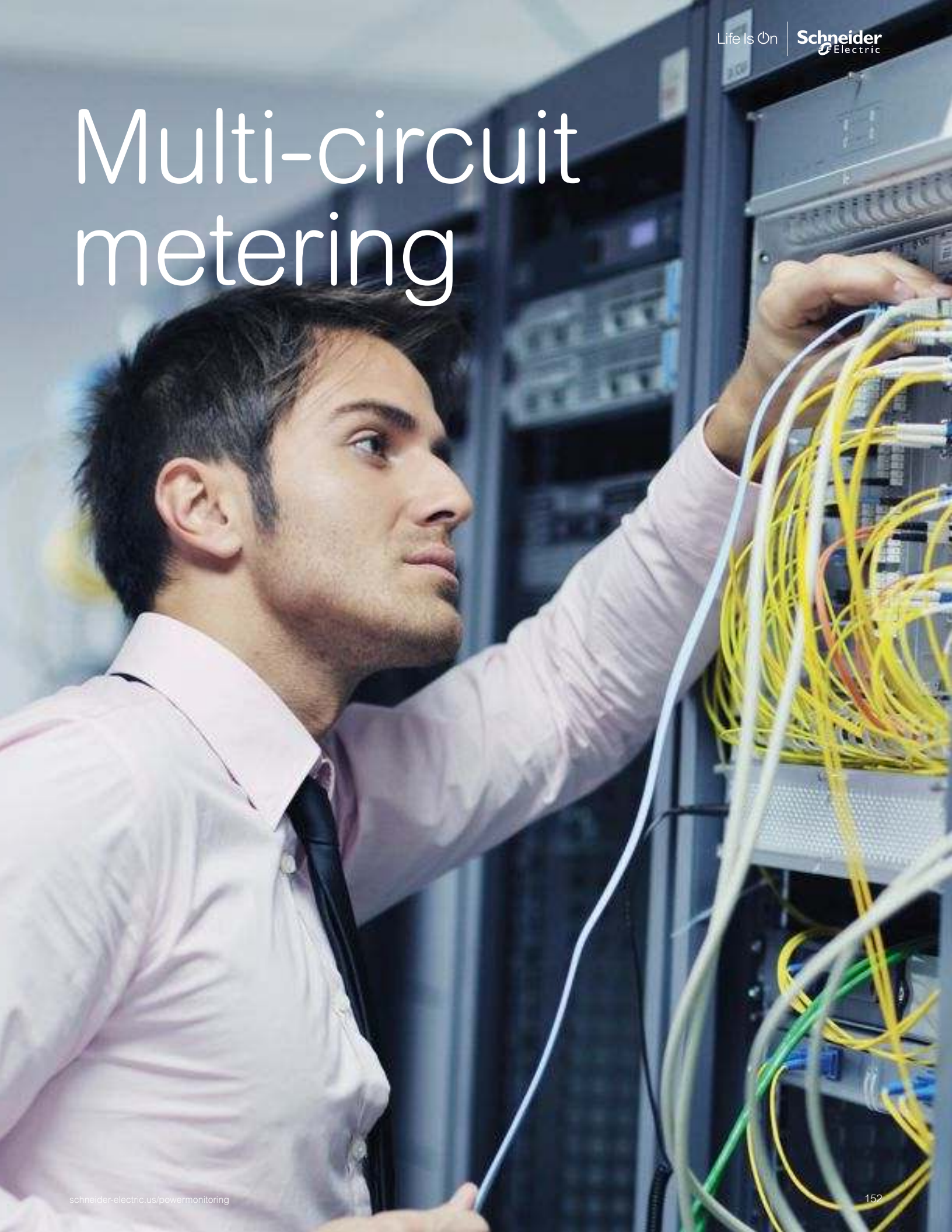

# Applications

This is an integrated solution for monitoring multi-circuits and mains by using a single meter. The meter is designed for use in both new build and retrofit and is used for critical power operations in data centers and for energy management in buildings.

# Product overview

## Multi-circuit metering

This solution is ideal for data center managers, energy or facility managers, engineers, and operational executives who are responsible for delivering power to critical applications.

In corporate and hosted data center facilities, this technology helps you plan and optimize the critical power infrastructure to meet the demands of continuous availability. Enclosed solutions like the EM4000 and EM4800 provide a compact, "energy management in a box" solution and are ideal for and tenant metering.

- PowerLogic BCPM
- PowerLogic EM4000
- PowerLogic EM4800
- PowerLogic EM4900

MULTI-CIRCUIT METERING

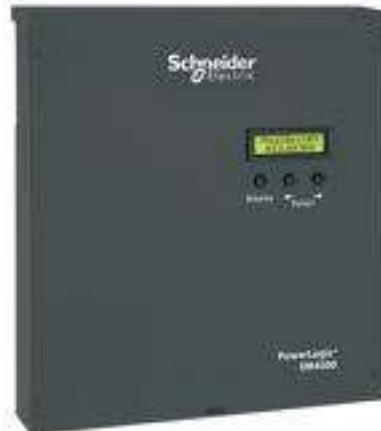

## MULTI-CIRCUIT METERING

# PowerLogic BCPM

The PowerLogic BCPM is a highly accurate, full-featured metering product designed for the unique, multi-circuit, minimal-space requirements of a high-performance power distribution unit (PDU) or remote power panel (RPP).

It offers Class 1 (1%) power and energy system accuracy (including 50 A or 100 A CTs) on all branch channels. The BCPM monitors up to 84 branch circuits and the incoming power mains to provide information on a complete PDU. Full alarming capabilities ensure that potential issues are dealt with before they become problems.

## Applications

- Maximize uptime and avoid outages
- Optimize existing infrastructure
- Improve power distribution efficiency
- Track usage and allocate energy costs
- Enable accurate submetering



## MULTI-CIRCUIT METERING

### The solution for

Markets that can benefit from a solution that includes PowerLogic BCPM series meters:

- Data centers
  - Buildings
- 

### Benefits

The flexible BCPM fits any PDU or RPP design and supports both new and retrofit installations. It has exceptional dynamic range and accuracy, and optional feature sets to meet the energy challenges of mission-critical data centers.

---

### Competitive advantages

- Fit any PDU or RPP design for both new and retrofit projects
- Class 1.0 system accuracy
- Ethernet communication

### Conformity of standards

- IEC 61010

MULTI-CIRCUIT METERING

# PowerLogic BCPM

## Functions and characteristics



PowerLogic™ BCPM A/B/C main board

The ideal solution for data center managers, energy or facility managers, engineers, and operational executives who are responsible for delivering power to critical applications. The BCPM helps you plan and optimize the critical power infrastructure to meet the demands of continuous availability.

### Applications

- Revenue grade sub-billing
- Data center load monitoring and alarming
- Comprehensive monitoring of lighting control panels
- Maximize uptime and avoid outages
- Optimize existing infrastructure
- Effectively plan future infrastructure needs
- Improve power distribution efficiency
- Track usage and allocate energy costs

### Main characteristics

Monitor up to 84 branch circuits with a single BCPM.

### Ideal for installation in both new PDUs and retrofit projects

- New installations: BCPM with solid-core CTs monitors up to 84 branch circuits using 2 or 4 CT strips. Solid-core CTs are rated to 100 A CTs and are mounted on strips to simplify installation. CT strips are available with 12, 8, or 21 CTs per strip on 0.71 in (18 mm) spacings. 21 CT strips with 0.75 in (19 mm) or 0.98 in (25 mm) spacings are also available.
- Retrofit projects: BCPMSC with split-core CTs is ideal for retrofits. Any number of split-core CTs, up to 84 maximum, can be installed with a single BCPM. Three sizes of CT are supported (50 A, 100 A, and 200 A) and all three CT sizes can be used on a single BCPM. Adapter boards with terminals for split-core CTs can be mounted using DIN-rail, Snaptrack, or on a common mounting plate with the main board (42 ch Y63 models only).



PowerLogic™ BCPME measurement unit

### Class 1.0 system accuracy for Revenue Grade measurements

- Branch power and energy measurements fully meet ANSI and IEC Class 1 accuracy requirements with 50 A or 100 A CTs included. No need to de-rate meter branch accuracy to allow for CTs. Voltage and current measurement accuracy is 0.5% and currents are measured down to 50 mA. Easily differentiate between the flow of low current and a trip where no current flows.

### Designed to fit any PDU or RPP design

- Lowers your total installation costs as well as the cost per meter point by supporting both new and retrofit installations.

### New models with integrated Ethernet offer broad protocol support

All models integrate easily into existing networks using Modbus RTU communications over an RS-485 serial link. BCPME and BCPMSCE models offer integrated Ethernet and add support for Modbus TCP, BACnet IP, BACnet MS/TP, and SNMP. An optional external gateway can be added to all other models to add the same capability.

### Flexible configuration capability

- Set the ordering and orientation of CT strips, assign individual CT sizes and phases
- Support for 1-, 2-, and 3-pole breakers in any configuration.

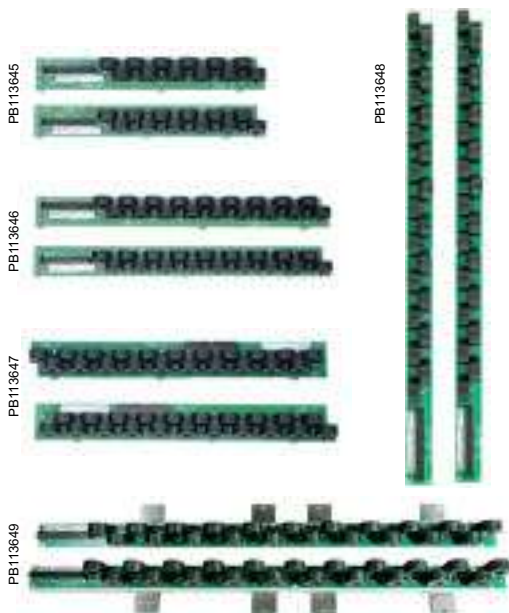

PowerLogic™ BCPM split-core 0.47 in, 0.71 in, 0.83 in, .75 in and 1 in CTs strips

# PowerLogic BCPM

## Functions and characteristics (cont.)

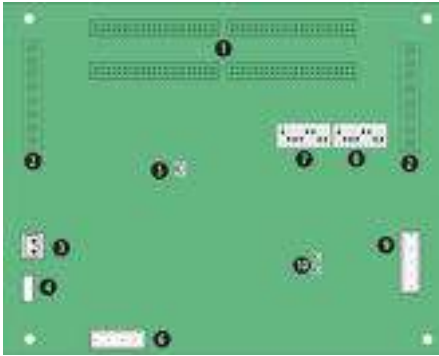

PE89167

**PowerLogic BCPM**

- 1 50-pin ribbon cable connectors (data acquisition board)
- 2 Auxiliary inputs
- 3 Control (mains) power connection
- 4 Control power fuse
- 5 Alive LED
- 6 Voltage taps
- 7 Communications address DIP switches
- 8 Communications settings DIP switch
- 9 RS-485 2 connection
- 10 RS-485 LEDs

Selection guide		BCPMA	BCPMB	BCPMC	BCPME
<b>General</b>					
Use on LV systems		■	■	■	■
<b>Power and energy measurements</b>					
Mains		■	■	-	■
Branch circuits		■	-	-	■
<b>Instantaneous RMS values</b>					
Voltage, frequency		■	■	-	■
Current		■	■	■	■
Active power	Total and per phase	■	■ (mains only)	-	■
Power factor	Total and per phase	■	■ (mains only)	-	■
<b>Energy values</b>					
Active energy		■	■ (mains only)	-	■
<b>Demand values</b>					
Total active power	Present and max values	■	■ (mains only)	-	■
<b>Power quality measurements</b>					
Detection of over-voltage/under-voltage		■	■	-	■
<b>Alarming</b>					
Alarms		■	■	■	■
<b>Power supply</b>					
AC version		90-277 V AC	90-277 V AC	90-277 V AC	100-277 V AC
<b>Communication</b>					
RS-485 port		■	■	■	■
Modbus protocol		■	■	■	■
Ethernet Port		1★	1★	1★	■
Modbus RTU protocol		1★	1★	1★	■
BACnet IP protocol		1★	1★	1★	■
BACnet MS/TP protocol		1★	1★	1★	■
SNMP protocol		1★	1★	1★	■
<b>Technical specifications</b>					
<b>Electrical characteristics</b>					
Type of measurement					
Accuracy	Power/energy	1% system accuracy (including 50 A or 100 A branch CTs)			
	Voltage	±0.5% of reading			
	Current	±0.5% of reading			
	Minimum "ON" current	50 mA			
Sampling rate points per cycle		2560 Hz			
Data update rate		1.8 seconds (Modbus), 14 seconds (BACnet) 20 seconds (SNMP)			
Input-voltage characteristics	Measured voltage	150 – 480 V AC L-L★★ 90 – 277 V AC L-N★★			
	Measurement range	150 – 480 V AC L-L★★ 90 – 277 V AC L-N★★			
Power supply	AC	100 – 277 V AC (50/60 Hz)			
Auxiliary CT current input range		0-0.333 V; CTs must be rated for use with Class 1 voltage inputs			

- ★ 1 Add E8951 Gateway
- ★★ Feature sets A, B, and E only

# PowerLogic BCPM

## Functions and characteristics (cont.)

Technical specifications (cont'd)		
<b>Mechanical characteristics</b>		
Weight		3.31 lb (1.5 kg)
Dimensions	A/B/C model circuit board	11.34 x 5.75 in (288 x 146 mm)
	E model housing (w/ brackets on long sides)	9.96 in W x 12.01 in H x 2.80 in D (253 mm W x 307 mm H x 71 mm D)
	E model housing (w/ brackets on short ends)	8.27 in W x 13.90 in H x 2.76 in D (210 mm W x 353 mm H x 71 mm D)
<b>Environmental conditions</b>		
Operating temperature		0 to 60 °C
Storage temperature		-40 °C to 70 °C
Installation category		CAT III, pollution degree 2
<b>Safety</b>		
Europe		IEC 61010
U.S. and Canada		UL 508 open type device
<b>Communication</b>		
RS-485 (A/B/C models)		Baud rate: DIP-switch selectable 9600, 19200, 38400 DIP-switch selectable 2-wire or 4-wire RS-485; parity selectable: even, odd or none
RS-485 (E Models)		Baud rate: configured via web server; baud selectable: 9600, 19200, 38400; parity selectable: even, odd or none; 2-wire RS-485
Ethernet (E models)		10/100 Mbit Ethernet; RJ-45 connection; static IP or DHCP
Protocols		Modbus RTU on all models, BCPME models also support Modbus TCP, SNMP, BACnet IP, and BACnet MS/TP
<b>Firmware characteristics</b>		
Detection of over-voltage/ under-voltage		User-defined alarm thresholds for over-voltage and under-voltage detection
Alarms		Four alarm levels: high-high, high, low, and low-low (users define the setpoints for each; each alarm has a latching status to alert the operator that an alarm has previously occurred; high and low alarms have instantaneous status to let the operator know if the alarm state is still occurring)
Firmware update		Update via Modbus
<b>1/3 V low-voltage CT (LVCT) for mains — specifications</b>		
<b>Electrical characteristics</b>		
Accuracy		1% from 10% to 100% of rated current (LVCT0xxx0S/1S/2S/3S/4S [split-core]) 0.5% from 5% to 100% of rated current (LVCT2xxx0S/2S/3S [solid-core])
Frequency range		50/60 Hz
Leads		18 AWG, 600 V AC, 1.8 m standard length
Max voltage L-N sensed conductor		300 V AC (LVCT0xxx0S) 600 V AC (LVCT0xxx1S/2S/3S/4S, LVCT2xxxxS)
<b>Environmental conditions</b>		
Operating temperature		0°C to 70°C (LVCT0xxx0S/1S) -15°C to 60°C (LVCT0xxx2S/3S/4S less than 2400 A) -15°C to 60°C (LVCT02404S [2400 A]) -40°C to 85°C (LVCT2xxx0S/2S/3S [solid-core])
Storage temperature		-40°C to 105°C (LVCT0xxx0S/1S) -40°C to 70°C (LVCT0xxx2S/3S/4S) -50°C to 105°C (LVCT2xxx0S/2S/3S [solid-core])
Humidity range		0% to 95% non-condensing

- ★ 1 Add E8951 Gateway
- ★★ Feature sets A, B, and E only

# PowerLogic BCPM

## Functions and characteristics (cont.)

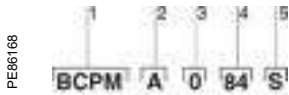

PEB6168

Example BCPM with solid-core CTs part number

- 1 Model
- 2 Feature set
- 3 CT spacing (solid-core models only)
- 4 Number of circuits
- 5 Brand

The PowerLogic BCPM uses .333 V AC output split-core CTs for the auxiliary inputs. These CTs are ordered separately from the BCPM.



BCPM part numbers			
BCPM with solid-core CTs			
Item	Code	Description	
1 Model	BCPM	BCPM with solid-core CTs; highly accurate meter that monitors branch circuits and the incoming power mains and includes full alarming capabilities	
	2 Feature set	A	Advanced — monitors power and energy per circuit and mains, Modbus RTU only (add E8951 for other protocols), meter main board comes on an aluminum mounting plate
		B	Intermediate — monitors current per circuit, power, and energy per mains, Modbus RTU only (add E8951 for other protocols), meter main board comes on an aluminum mounting plate
		C	Basic — monitors current only per circuit and mains, Modbus RTU only (add E8951 for other protocols), meter main board comes on an aluminum mounting plate
		E	Advanced, with Ethernet — monitors power and energy per circuit and mains, meter main board is enclosed in a metal housing
3 CT spacing	0	0.75 in (19 mm) CT spacing	
	1	1.02 in (26 mm) CT spacing	
	2	0.71 in (18 mm) CT spacing	
4 Number of circuits	24	24 circuits, (2) 18-CT strips (0.71 in (18 mm) spacing only)	
	36	36 circuits, (2) 18-CT strips (0.71 in (18 mm) spacing only)	
	42	42 circuits, (2) 21-CT strips	
	48	48 circuits, (4) 18-CT strips (0.71 in (18 mm) spacing only)	
	72	72 circuits, (4) 18-CT strips (0.71 in (18 mm) spacing only)	
	84	84 circuits, (4) 21-CT strips	
5 Brand	S	Schneider Electric	

★ Quantity and style of CT strips and cables included varies by model.

MULTI-CIRCUIT METERING

# PowerLogic BCPM

## Functions and characteristics (cont.)

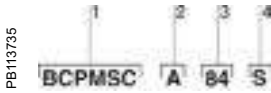

Example BCPMSC with split-core CTs part number

- 1 Model
- 2 Feature set
- 3 Number of circuits
- 4 Brand

The BCPMSC models with 1, 2, or Y63 as the number of circuits DO NOT INCLUDE ANY branch CTs or ribbon cables (they include only the main board and adapter board assemblies). These models are provided to allow users to order a specific combination of CT quantities, CT sizes, CT lead lengths, and ribbon cable styles and lengths. The CTs and cables must be ordered separately.

Models with more than two circuits include 50 A branch CTs with two meter leads and 1.8 M round ribbon cables.

The PowerLogic BCPMSC uses .333 V AC output split-core CTs for the auxiliary inputs. These CTs are ordered separately from the BCPM.



BCPM with split-core CTs		
Model	BCPMSC	BCPM with split-core CTs; highly accurate meter that monitors branch circuits and the incoming power mains and includes full alarming capabilities
2 Feature set	A	Advanced — monitors power and energy per circuit and mains, Modbus RTU only (add E8951 for other protocols), meter main board comes on an aluminum mounting plate
	B	Intermediate — monitors current per circuit, power and energy per mains, Modbus RTU only (add E8951 for other protocols), meter main board comes on an aluminum mounting plate
	C	Basic — monitors current only per circuit and mains, Modbus RTU only (add E8951 for other protocols), meter main board comes on an aluminum mounting plate
	E	Advanced, with Ethernet — monitors power and energy per circuit & mains, meter main board is enclosed in a metal housing
4 Number of circuits	1	42 circuits (no branch CTs or ribbon cables, order separately)
	2	84 circuits (no branch CTs or ribbon cables, order separately)
	Y63	42 circuits main and adapter boards on single mounting plate (no branch CTs or ribbon, order separately)
	30	30 split-core CTs (50 A)
	42	42 split-core CTs (50 A)
	60	60 split-core CTs (50 A)
	84	84 split-core CTs (50 A)
5 Brand	S	Schneider Electric

MULTI-CIRCUIT METERING

# PowerLogic BCPM

## Functions and characteristics (cont.)



Flat ribbon cable



Round ribbon cable

### Cabling and connection

Flat ribbon cables are recommended for use when the BCPM printed circuit board will be mounted inside of the PDU that is being monitored. Round ribbon cables are the preferred choice when the ribbon cable will be threaded through conduit.



BCPMSCxY63S 42-circuit split-core models come with the main board, (2) adapter boards and ribbon cables all mounted on a backplate, to simplify installation.

BCPM Commercial reference numbers for solid and split-core CTs	
BCPM with split-core CTs Description	Commercial ref. no.
42-circuit solid-core power and energy meter, 100 A CTs (2 strips), 0.75 in (19 mm) spacing	<b>BCPMA042S</b>
84-circuit solid-core power and energy meter, 100 A CTs (4 strips), 0.75 in (19 mm) spacing	<b>BCPMA084S</b>
42-circuit solid-core power and energy meter, 100 A CTs (2 strips), 0.98 in (25 mm) spacing	<b>BCPMA142S</b>
84-circuit solid-core power and energy meter, 100 A CTs (4 strips), 0.98 in (25 mm) spacing	<b>BCPMA184S</b>
24-circuit solid-core power and energy meter, 100 A CTs (2 strips), 0.71 in (18 mm) spacing	<b>BCPMA224S</b>
36-circuit solid-core power and energy meter, 100 A CTs (2 strips), 0.71 in (18 mm) spacing	<b>BCPMA236S</b>
42-circuit solid-core power and energy meter, 100 A CTs (2 strips), 0.71 in (18 mm) spacing	<b>BCPMA242S</b>
48-circuit solid-core power and energy meter, 100 A CTs (4 strips), 0.71 in (18 mm) spacing	<b>BCPMA248S</b>
72-circuit solid-core power and energy meter, 100 A CTs (4 strips), 0.71 in (18 mm) spacing	<b>BCPMA272S</b>
84-circuit solid-core power and energy meter, 100 A CTs (4 strips), 0.71 in (18 mm) spacing	<b>BCPMA284S</b>
42-circuit solid-core branch current, mains power meter, 100 A CTs (2 strips), 0.75 in (19 mm) spacing	<b>BCPMB042S</b>
84-circuit solid-core branch current, mains power meter, 100 A CTs (4 strips), 0.75 in (19 mm) spacing	<b>BCPMB084S</b>
42-circuit solid-core branch current, mains power meter, 100 A CTs (2 strips), 0.98 in (25 mm) spacing	<b>BCPMB142S</b>
84-circuit solid-core branch current, mains power meter, 100 A CTs (4 strips), 0.98 in (25 mm) spacing	<b>BCPMB184S</b>
24-circuit solid-core branch current, mains power meter, 100 A CTs (2 strips), 0.71 in (18 mm) spacing	<b>BCPMB224S</b>
36-circuit solid-core branch current, mains power meter, 100 A CTs (2 strips), 0.71 in (18 mm) spacing	<b>BCPMB236S</b>
42-circuit solid-core branch current, mains power meter, 100 A CTs (2 strips), 0.71 in (18 mm) spacing	<b>BCPMB242S</b>
48-circuit solid-core branch current, mains power meter, 100 A CTs (4 strips), 0.71 in (18 mm) spacing	<b>BCPMB248S</b>
72-circuit solid-core branch current, mains power meter, 100 A CTs (4 strips), 0.71 in (18 mm) spacing	<b>BCPMB272S</b>
84-circuit solid-core branch current, mains power meter, 100 A CTs (4 strips), 0.71 in (18 mm) spacing	<b>BCPMB284S</b>
42-circuit solid-core branch current meter, 100 A CTs (2 strips), 19 mm spacing	<b>BCPMC042S</b>
84-circuit solid-core branch current meter, 100 A CTs (4 strips), 19 mm spacing	<b>BCPMC084S</b>
42-circuit solid-core branch current meter, 100 A CTs (2 strips), 0.98 in (25 mm) spacing	<b>BCPMC142S</b>
84-circuit solid-core branch current meter, 100 A CTs (4 strips), 0.98 in (25 mm) spacing	<b>BCPMC184S</b>
24-circuit solid-core branch current meter, 100 A CTs (2 strips), 0.71 in (18 mm) spacing	<b>BCPMC224S</b>
36-circuit solid-core branch current meter, 100 A CTs (2 strips), 0.71 in (18 mm) spacing	<b>BCPMC236S</b>
42-circuit solid-core branch current meter, 100 A CTs (2 strips), 0.71 in (18 mm) spacing	<b>BCPMC242S</b>
48-circuit solid-core branch current meter, 100 A CTs (4 strips), 0.71 in (18 mm) spacing	<b>BCPMC248S</b>
72-circuit solid-core branch current meter, 100 A CTs (4 strips), 0.71 in (18 mm) spacing	<b>BCPMC272S</b>
84-circuit solid-core branch current meter, 100 A CTs (4 strips), 0.71 in (18 mm) spacing	<b>BCPMC284S</b>
42-circuit solid-core power and energy meter w/ Ethernet, 100 A CTs (2 strips), 0.75 in (19 mm) spacing	<b>BCPME042S</b>
84-circuit solid-core power and energy meter w/ Ethernet, 100 A CTs (4 strips), 0.75 in (19 mm) spacing	<b>BCPME084S</b>
42-circuit solid-core power and energy meter w/ Ethernet, 100 A CTs (2 strips), 0.98 in (25 mm) spacing	<b>BCPME142S</b>
84-circuit solid-core power and energy meter w/ Ethernet, 100 A CTs (4 strips), 0.98 in (25 mm) spacing	<b>BCPME184S</b>
24-circuit solid-core power and energy meter w/ Ethernet, 100 A CTs (2 strips), 0.71 in (18 mm) spacing	<b>BCPME224S</b>
36-circuit solid-core power and energy meter w/ Ethernet, 100 A CTs (2 strips), 0.71 in (18 mm) spacing	<b>BCPME236S</b>
42-circuit solid-core power and energy meter w/ Ethernet, 100 A CTs (2 strips), 0.71 in (18 mm) spacing	<b>BCPME242S</b>
48-circuit solid-core power and energy meter w/ Ethernet, 100 A CTs (4 strips), 0.71 in (18 mm) spacing	<b>BCPME248S</b>
72-circuit solid-core power and energy meter w/ Ethernet, 100 A CTs (4 strips), 0.71 in (18 mm) spacing	<b>BCPME272S</b>
84-circuit solid-core power and energy meter w/ Ethernet, 100 A CTs (4 strips), 0.71 in (18 mm) spacing	<b>BCPME284S</b>

MULTI-CIRCUIT METERING

# PowerLogic BCPM

## Functions and characteristics (cont.)

PE86183



PowerLogic™ LVCT0xxxxS split-core low-voltage (1/3V) CTs for aux inputs (mains) are ideal for retrofit applications.

PB113652



PB113657



PB113658

PowerLogic™ LVCT2xxxxS low-voltage (1/3V) solid-core CTs for aux inputs (mains) are ideal for panel builders (small, medium, and large).

The PowerLogic™ BCPM uses 0.333 V AC output split-core CTs for the auxiliary inputs. These CTs are ordered separately from the BCPM.

BCPM with split-core CTs (cont'd)	Commercial ref. no.
42-circuit split-core power and energy meter, CTs and cables sold separately	<b>BCPMSCA1S</b>
84-circuit split-core power and energy meter, CTs and cables sold separately	<b>BCPMSCA2S</b>
30-circuit split-core power and energy meter, (30) 50 A CTs and (2) 4' cables	<b>BCPMSCA30S</b>
42-circuit split-core power and energy meter, (42) 50 A CTs and (2) 4' cables	<b>BCPMSCA42S</b>
60-circuit split-core power and energy meter, (60) 50 A CTs and (4) 4' cables	<b>BCPMSCA60S</b>
42-circuit split-core power and energy meter, all boards on backplate, CTs and cables sold separately	<b>BCPMSCAY63S</b>
84-circuit split-core power and energy meter, with (84) 50 A CTs and (4) 4' cables	<b>BCPMSCA84S</b>
42-circuit split-core branch current, mains power meter, CTs and cables sold separately	<b>BCPMSCB1S</b>
84-circuit split-core branch current, mains power meter, CTs and cables sold separately	<b>BCPMSCB2S</b>
30-circuit split-core branch current, mains power meter, (30) 50 A CTs and (2) 4' cables	<b>BCPMSCB30S</b>
42-circuit split-core branch current, mains power meter, (42) 50 A CTs and (2) 4' cables	<b>BCPMSCB42S</b>
60-circuit split-core branch current, mains power meter, (60) 50 A CTs and (4) 4' cables	<b>BCPMSCB60S</b>
42-circuit split-core branch current, mains, all boards on backplate, CTs and cables sold separately	<b>BCPMSCBY63S</b>
84-circuit split-core branch current, mains power meter, (84) 50 A CTs and (4) 4' cables	<b>BCPMSCB84S</b>
42-circuit split-core current meter, CTs and cables sold separately	<b>BCPMSCC1S</b>
84-circuit split-core current meter, CTs and cables sold separately	<b>BCPMSCC2S</b>
30-circuit split-core current meter, (30) 50 A CTs and (2) 4' cables	<b>BCPMSCC30S</b>
42 circuit split-core current meter, (42) 50 A CTs and (2) 4' cables	<b>BCPMSCC42S</b>
60-circuit split-core current meter, (60) 50 A CTs and (4) 4' cables	<b>BCPMSCC60S</b>
42-circuit split-core current meter, all boards on backplate, CTs and cables sold separately	<b>BCPMSCCY63S</b>
84-circuit split-core current meter, (84) 50A CTs and (4) 4' cables	<b>BCPMSCC84S</b>
42-circuit split-core power and energy meter w/ Ethernet, CTs and cables sold separately	<b>BCPMSCCE1S</b>
84-circuit split-core power and energy meter w/ Ethernet, CTs and cables sold separately	<b>BCPMSCCE2S</b>
30-circuit split-core power and energy meter w/ Ethernet, (30) 50A CTs and (2) 1.21 m cables	<b>BCPMSCCE30S</b>
42-circuit split-core power and energy meter w/ Ethernet, (42) 50A CTs and (2) 1.21 m cables	<b>BCPMSCCE42S</b>
60-circuit split-core power and energy meter w/ Ethernet, (60) 50A CTs and (4) 1.21 m cables	<b>BCPMSCCE60S</b>
84-circuit split-core power and energy meter w/ Ethernet, (84) 50A CTs and (4) 1.21 m cables	<b>BCPMSCCE84S</b>

# PowerLogic BCPM

## Functions and characteristics (cont.)

BCPM split-core branch CTs and adapter boards		
BCPM adapter boards, Quantity 2, for split-core BCPM		<b>BCPMSCADPBS</b>
BCPM 50 A split-core CTs, Quantity 6, 1.8 m lead lengths		<b>BCPMSCCT0</b>
BCPM 50 A split-core CTs, Quantity 6, 6 m lead lengths		<b>BCPMSCCT0R20</b>
BCPM 100 A split-core CTs, Quantity 6, 1.8 m lead lengths		<b>BCPMSCCT1</b>
BCPM 100 A split-core CTs, Quantity 6, 6 m lead lengths		<b>BCPMSCCT1R20</b>
BCPM 200 A split-core CTs, Quantity 1, 1.8 m lead lengths		<b>BCPMSCCT3</b>
BCPM 200 A split-core CTs, Quantity 1, 6 m lead lengths		<b>BCPMSCCT3R20</b>
Additional accessories for use with BCPM products		
BCPM circuit board cover		<b>BCPMCOVERS</b>
CT repair kit for solid-core BCPM (includes one CT)		<b>BCPMREPAIR</b>
Additional 100A split-core CT for use with solid-core repair kit		<b>H6803R-0100</b>
Modbus to BACnet protocol converter		<b>E8951</b>
Flat Ribbon cable (quantity 1) for BCPM, length = 0.45 m		<b>CBL008</b>
Flat Ribbon cable (quantity 1) for BCPM, length = 1.2 m		<b>CBL016</b>
Flat Ribbon cable (quantity 1) for BCPM, length = 1.5 m		<b>CBL017</b>
Flat Ribbon cable (quantity 1) for BCPM, length = 1.8 m		<b>CBL018</b>
Flat Ribbon cable (quantity 1) for BCPM, length = 2.4 m		<b>CBL019</b>
Flat Ribbon cable (quantity 1) for BCPM, length = 3.0 m		<b>CBL020</b>
Flat Ribbon cable (quantity 1) for BCPM, length = 6.1 m		<b>CBL021</b>
Round Ribbon cable (quantity 1) for BCPM, length = 1.2 m		<b>CBL022</b>
Round Ribbon cable (quantity 1) for BCPM, length = 3 m		<b>CBL023</b>
Round Ribbon cable (quantity 1) for BCPM, length = 6.1 m		<b>CBL024</b>
Round Ribbon cable (quantity 1) for BCPM, length = 0.5 m		<b>CBL031</b>
Round Ribbon cable (quantity 1) for BCPM, length = 0.8 m		<b>CBL033</b>
1/3 V low-voltage split-core CTs for aux inputs (mains)		
Amperage rating	Inside dimensions	Commercial ref. no.
50 A	0.39 x 0.43 in (10 x 11 mm)	<b>LVCT00050S</b>
200 A	0.63 x 0.79 in (16 x 20 mm)	<b>LVCT00101S</b>
200 A	1.26 x 1.26 in (32 x 32 mm)	<b>LVCT00202S</b>
100 A	1.18 x 1.22 in (30 x 31 mm)	<b>LVCT00102S</b>
200 A	1.18 x 1.22 in (30 x 31 mm)	<b>LVCT00202S</b>
300 A	1.18 x 1.22 in (30 x 31 mm)	<b>LVCT00302S</b>
400 A	2.44 x 2.87 in (62 x 73 mm)	<b>LVCT00403S</b>
600 A	2.44 x 2.87 in (62 x 73 mm)	<b>LVCT00603S</b>
800 A	2.44 x 2.87 in (62 x 73 mm)	<b>LVCT00803S</b>
800 A	2.44 x 5.47 in (62 x 139 mm)	<b>LVCT00804S</b>
1000 A	2.44 x 5.47 in (62 x 139 mm)	<b>LVCT01004S</b>
1200 A	2.44 x 5.47 in (62 x 139 mm)	<b>LVCT01204S</b>
1600 A	2.44 x 5.47 in (62 x 139 mm)	<b>LVCT01604S</b>
2000 A	2.44 x 5.47 in (62 x 139 mm)	<b>LVCT02004S</b>
2400 A	2.44 x 5.47 in (62 x 139 mm)	<b>LVCT02404S</b>
1/3 V low-voltage solid-core CTs for aux inputs (mains)		
Amperage rating	Inside dimensions	Commercial ref. no.
50 A	0.39 in (10 mm)	<b>LVCT20050S</b>
100 A	0.39 in (10 mm)	<b>LVCT20100S</b>
200 A	0.98 in (25 mm)	<b>LVCT20202S</b>
400 A	1.22 in (31 mm)	<b>LVCT20403S</b>

MULTI-CIRCUIT METERING

# PowerLogic BCPM

## Dimensions and connection

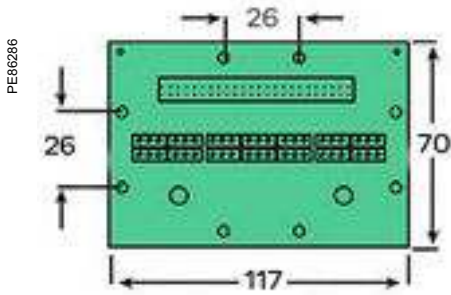

PowerLogic BCPM adapter board  
(one board per 21 split-core branch CTs)

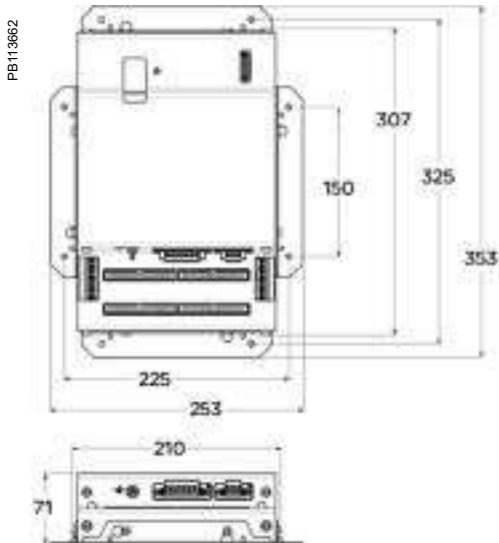

### PowerLogic BCPM dimensions

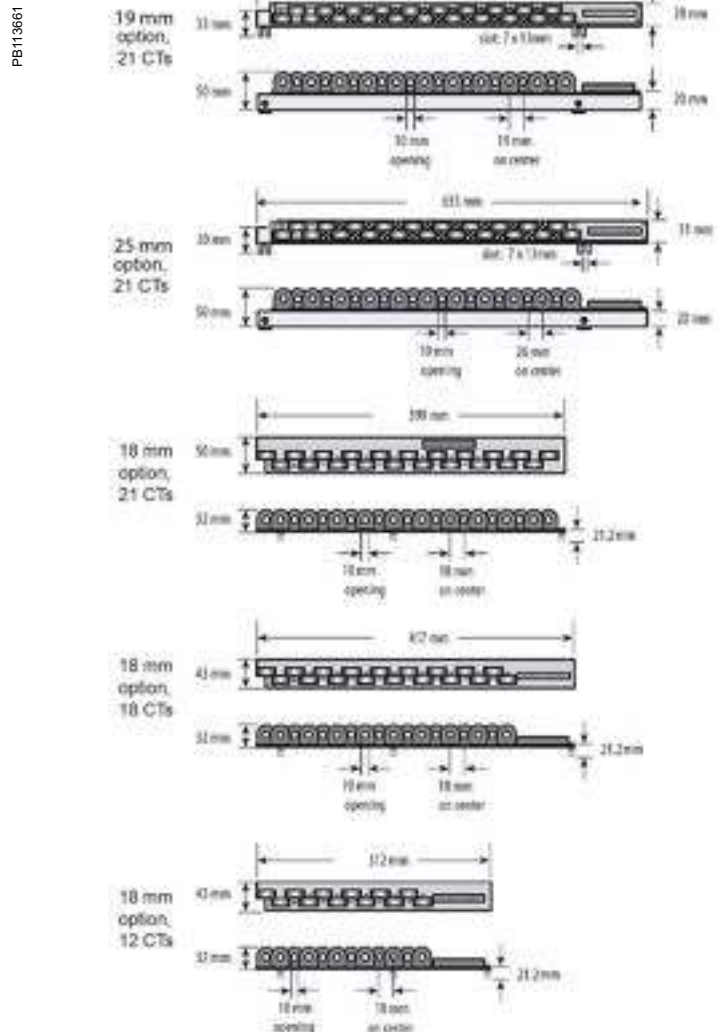
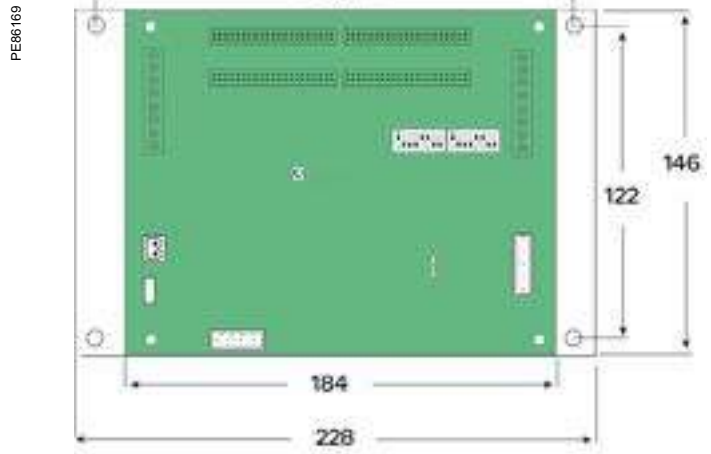

MULTI-CIRCUIT METERING

# PowerLogic BCPM

## Dimensions and connection (cont.)

### 50A-200A split-core CT dimensions

PB113669\_m

These dimensions apply to both BCPMSCCTxx (branch CTs) and LVCT0xxxx0S/1S (for mains) 50 A-200 A CT families.

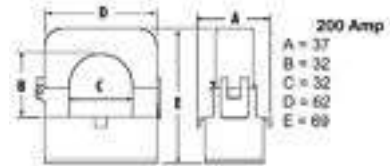
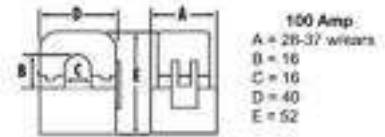
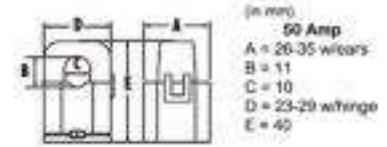

### Solid-core CT dimensions

PB113660

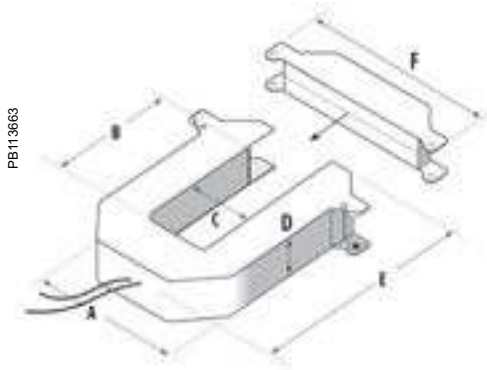
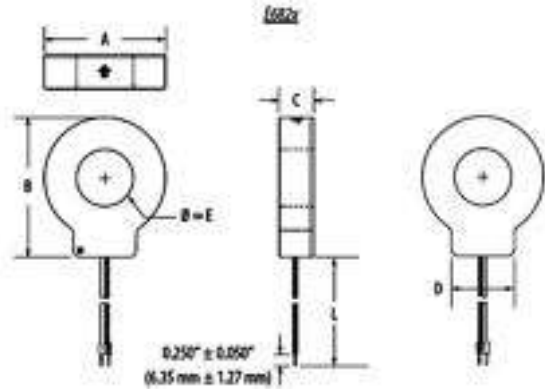

PB113663

Model	L	A	B	C	D	E
LVCT200505	1.97 y (1.8 m)	1.30 in (33 mm)	1.50 in (38 mm)	0.71 in (18 mm)	0.83 in (21 mm)	0.39 in (10 mm)
LVCT201005	1.97 y (1.8 m)	2.32 in (59 mm)	2.60 in (66 mm)	0.71 in (18 mm)	1.22 in (31 mm)	0.98 in (25 mm)
LVCT202025	1.97 y (1.8 m)	2.76 in (70 mm)	3.23 in (82 mm)	0.98 in (25 mm)	1.41 in (36 mm)	1.22 in (31 mm)

1/3 V low-voltage CT form factor		
Small form factor 100/200/300 A	Medium form factor 400/600/800 A	Large form factor 800/1000/1200/ 1600/2000/2400 A
A = 3.78 in (96 mm)	A = 4.92 in (125 mm)	A = 4.92 in (125 mm)
B = 1.18 in (30 mm)	B = 2.87 in (73 mm)	B = 5.47 in (139 mm)
C = 1.22 in (31 mm)	C = 2.44 in (62 mm)	C = 2.44 in (62 mm)
D = 1.18 in (30 mm)	D = 1.18 in (30 mm)	D = 1.18 in (30 mm)
E = 3.94 in (100 mm)	E = 5.20 in (132 mm)	E = 7.91 in (201 mm)
F = 4.76 in (121 mm)	F = 5.94 in (151 mm)	F = 5.94 in (151 mm)

MULTI-CIRCUIT METERING

# PowerLogic BCPM

## Dimensions and connection (cont.)

### PowerLogic BCPM with solid-core CT strips installation details

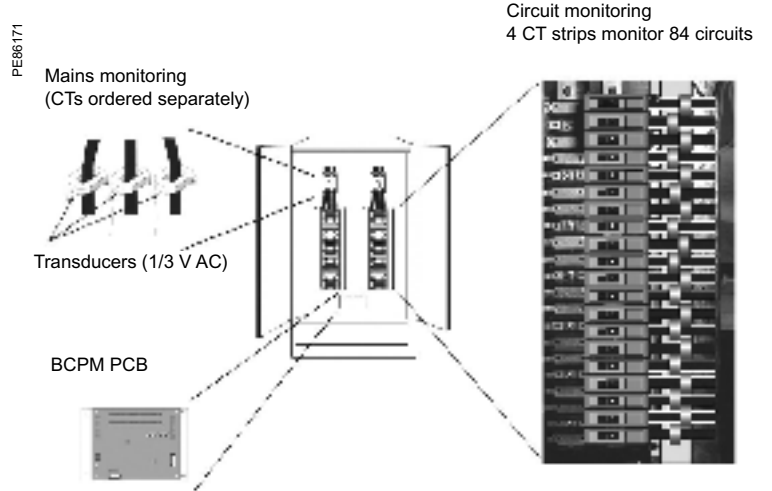

### PowerLogic BCPM with split-core CTs installation details

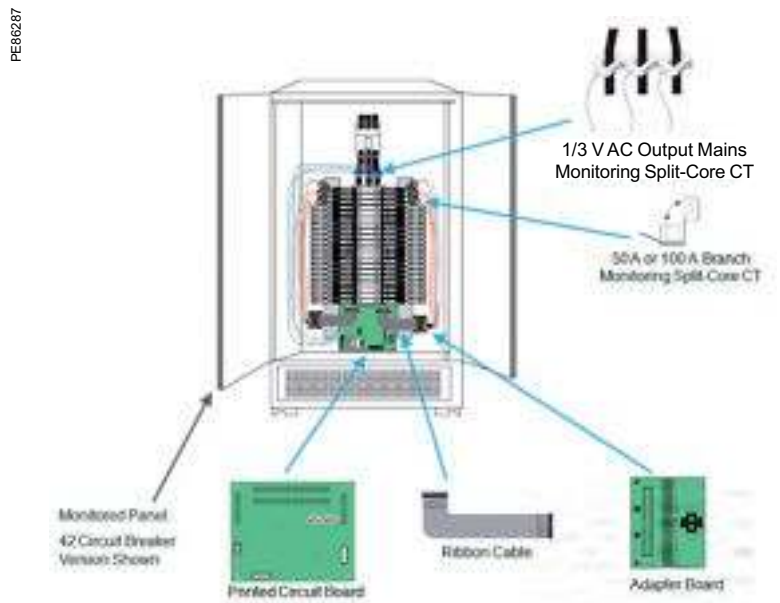

See appropriate Installation Guide for this product.

NOTES

---

## MULTI-CIRCUIT METERING

# PowerLogic EM4900 series

The PowerLogic EM4900 series multi-circuit meters make it easy to add many metering points without having to purchase, mount, wire, and commission individual energy meters. Simply add a single device with common voltage inputs and communication interface that can measure the current, voltage, power, energy consumption, and total harmonic distortion (THD) of up to (14) 3-phase circuits with a single board, or up to (28) 3-phase circuits with a two board configuration. Save on both equipment cost and installation.

## Applications

- Commercial and residential subtenant billing
- Load-based cost allocation
- Measuring for load balancing and demand response
- Overload protection

PB117150

PB117149



## MULTI-CIRCUIT METERING

### The solution for

Markets that can benefit from a solution that includes PowerLogic EM4900 series meters:

- Buildings
  - Industry
  - Healthcare
  - Hotels, multi-dweller units (condos)
- 

### Benefits

System integrators' benefit

- Ease of integration
- Ease of setup
- Cost effectiveness

Panel builders' benefit

- Ease of installation
- Cost effectiveness
- Aesthetically pleasing
- Simplified ordering

End users' benefit

- Ease of use
  - Precision metering and sub-billing
  - Billing flexibility
  - Comprehensive, consistent, and superior performance
- 

### Competitive advantages

- Lower cost and space per metering point
- Adapts to any mix of metering needs (1ph, 2ph, 3ph with or without neutral wire)
- Class 0.5 accuracy for revenue grade measurement
- THD monitoring to help identify problem loads and early wear and tear
- Capable of concurrent communication to software packages, including PowerLogic software packages, and third-party systems

### Power management solutions

Schneider Electric provides innovative power management solutions to increase your energy efficiency and cost savings, maximize electrical network reliability and availability, and optimize electrical asset performance.

---

### Conformity of standards

- EN 61000-6-3 Class B — Part 6-3
- EN 61000-6-3 Class B — Part 6-3
- EN 61000-6-4 Class A — Part 6
- EN 61010-1 — Part 1
- EN 61326-1 Class A — Part 1
- EN 61326-1 Class B — Part 1
- IEC 62053-22 Class 0.5 — Part 21
- FCC 47 CFR Part 15 Class A and Class B
- UL 508 Open Device Type
- IEC 61010-1 — Part 1

MULTI-CIRCUIT METERING

# PowerLogic EM4900 series

## Functions and characteristics (cont.)



PowerLogic™ EM4914A



PowerLogic™ EM4914E

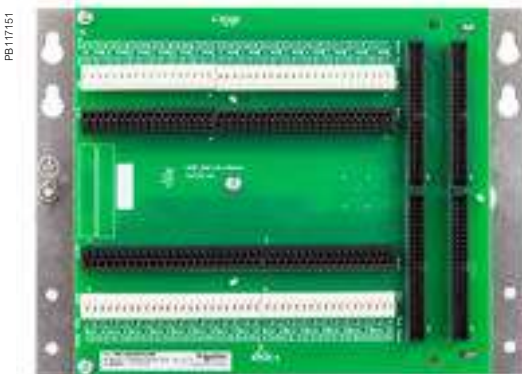

28-meter adapter board (EM4928A and EM4928E)

### Main characteristics

- Add metering points without large additional costs
  - Add up to 28 3-phase meters by installing a single product small enough to fit inside many distribution panels. Save on both equipment cost and installation cost. Common voltage and communication connections and color-coded push-in CT connections save installation time and effort.
- Class 0.5 accuracy for revenue grade measurements
  - Power and energy measurements with ANSI and IEC Class 0.5 accuracy provide the accuracy needed for tenant billing applications. Voltage and current measurement accuracy is 0.5 % and currents are measured down to 0.1% of the CT range. Easily differentiate between the flow of low current and a trip or load disconnect where no current flows.
- Total harmonics distortion measurements
  - Helps assess basic power quality to reduce risks to the load and provide indication of potential early wear and tear of the electrical network and its load.
- Common CTs, 1/3V outputs
  - CTs with low-voltage outputs eliminate the need for shorting blocks that add cost and labor to the installation. They also allow long CT lead extensions without compromising accuracy. Choose from a range of our CT styles and sizes or use any CTs with industry-standard 0.333V outputs.
- Models with integrated Ethernet offer broad protocol support
  - All models integrate easily into existing networks using Modbus RTU communications over an RS-485 serial link. EM49xxE models offer integrated Ethernet and add support for Modbus TCP, BACnet IP, BACnet MS/TP, and SNMP. Those Ethernet protocols can be run in parallel allowing multiple software to access the device (building management system, energy management system, etc.). An optional external gateway can be added to EM49xxA models to offer the same capability.
- Compatible with PowerLogic power monitoring software
  - Easily turn the large amount of data collected by the devices into useful decision-making information.
- Configure the meters you want
  - Choose 4, 8, 14, or 28 3-phase meters that are user-configurable to any combination of 1-, 2-, or 3-phase meters. Reconfigure channels as needed to monitor neutral current.



- 1 Model
- 2 Number of 3-phase meters (without neutral current)
- 3 Communication interfaces and protocols

MULTI-CIRCUIT METERING

# PowerLogic EM4900 series

## Functions and characteristics (cont.)

Measurements	
Measurement voltage	90 to 300 V AC L-N, 50/60 Hz
Total harmonic distortion (THD)	THD % voltage L-L, L-N, and THD % on current
Control power	
EM49xxA	90 to 277 V AC L-N, 50/60 Hz
EM49xxE	100 to 277 V AC L-N, 50/60 Hz
Accuracy	
Power/energy	IEC 62053-21 Class 0.5, ANSI C12.20 Class 0.5
Voltage	±0.5% of reading 90 to 277 V L-N
Current	±0.5% of reading from 2% to 100% of full-scale
Operation	
Sampling frequency	2560 Hz
Update rate	1.8 seconds (both panels)
Overload capability	22 kAIC
EM49xxA serial communication	
Type	Modbus RTU
Connection	DIP switch-selectable 2-wire or 4-wire, RS-485
Address	DIP switch-selectable address 1 to 247 (in pairs of 2) (See <i>Installation Guide</i> )
Baud rate	DIP switch-selectable 9600, 19200, 38400
Parity	DIP switch-selectable none, odd, or even
Communication format	8 data bits, 1 start bit, 1 stop bit
Termination	5-position plug-in connector (TX+ TX- SHIELD TX+/RX+ TX-/RX-)
EM49xxE serial communication	
Physical Interface	2-wire RS-485
Serial protocols supported	Modbus RTU or BACnet MS/TP
Address range	1 to 247 for Modbus RTU; 0 to 127 for BACnet MS/TP
Baud rate	9600, 19200, 38400
Parity	Modbus RTU: none, odd, or even BACnet MS/TP: none (fixed)
Communication format	8 data bits, 1 start bit, 1 stop bit
Termination	2x3 position connector
EM49xxE Ethernet communication	
Physical interface	Protocols supported
Protocols supported	Modbus TCP, BACnet IP, SNMP V2c
Wire size range	
Removable connectors on main board	24 to 12 AWG
CT Terminals and EM49xxE serial connector terminals	26 to 16 AWG
Terminal block torque	
Removable connectors	0.5 to 0.6 N-m
Mechanical	
Ribbon cable support (28-meter models only)	0.9 m round ribbon cable ships standard; up to 6 m flat or round available
Operating conditions	
Operating temperature range	0 to 60 °C (<95% RH non-condensing)
Storage temperature range	-40 to 70 °C
Altitude of operation	3000 m
Mounting location	Not suitable for wet locations; for indoor use only
Compliance information	
Agency approvals	UL 508 open type device <sup>1</sup> , IEC/EN 61010-1
Installation category	Cat III, pollution degree 2 <sup>2</sup>
Conducted emissions	EM49xxA Models: FCC part 15 Class B, EN 61000-6-3, EN 61326-1 Class B (residential and light industrial)
Radiated emissions	EM49xxE Models: FCC part 15 Class A, EN 6100-6-4, EN 61326-1 Class A
Conducted and radiated immunity	EN 61000-6-2 and EN 61326-1

<sup>1</sup>Install EM49xx in appropriate fire enclosure; if used with circuits higher than product ratings, circuits must be segregated per UL 508A Sec 17.5 (EM49xx internal circuitry are not circuits as defined by UL 508A)

<sup>2</sup>A pollution degree 2 environment must control conductive pollution and the possibility of condensation or high humidity; consideration must be given to the enclosure, the correct use of ventilation, thermal properties of the equipment and the relationship with the environment

# PowerLogic EM4900 series

## Functions and characteristics (cont.)

### 1/3 V low-voltage CT (LVCT)

Electrical characteristics	
Accuracy	1 % from 10 % to 100 % of rated current (LVCT0xxx0S/1S/2S/3S/4S [split core]) 0.5 % from 5 % to 100 % of rated current (LVCT2xxx0S/2S/3S [solid core])
Frequency range	50/60 Hz
Leads	18 AWG, 600 V AC, 1.8 m standard length
Max voltage L-N sensed conductor	300 V AC (LVCT0xxx0S) 600 V AC (LVCT0xxx1S/2S/3S/4S, LVCT2xxxxS)
Measurements	
Real time measurements	Current: multi-phase average and per phase Current phase angle per branch Real power (kW): multi-phase total and per phase Apparent power (kVA): multi-phase total and per phase Power factor: multi-phase average and per phase
Demand measurements	Current present demand: multi-phase average and per phase Real power (kW) present demand: multi-phase average and per phase
Historic maximums	Maximum instantaneous current: multi-phase average and per phase Maximum current demand: multi-phase average and per phase Maximum real power demand: multi-phase total and per phase
Accumulate energy	Energy (kWh): multi-phase total and per phase
Energy snapshots	Energy (kWh): multi-phase total and per phase

### EM4900 series part numbers

Item	Code	Description
1 Model	METSEEM49	Multi-circuit meter
2 Number of 3-phase meters	04	Up to (4) 3-phase meters (see table for variations)
	08	Up to (8) 3-phase meters (see table for variations)
	14	Up to (14) 3-phase meters (see table for variations)
	28	Up to (28) 3-phase meters (see table for variations)
3 Communication interfaces and protocols	A	RS-485 serial with Modbus RTU (add E8951 for other protocols)
	E	Ethernet with Modbus TCP, BACnet IP and SNMP protocols and RS-485 serial with Modbus RTU or BACnet IP

### Number of meters

Commercial ref. no.	"E" - integrated Ethernet	3ph no neutral	3ph no neutral	2ph	1ph
METSEEM4904A	METSEEM4904E	4	3	6	12
METSEEM4908A	METSEEM4908E	8	6	12	24
METSEEM4914A	METSEEM4914E	14	10	21	42
METSEEM4928A	METSEEM4928E	28	21	42	84

### Number of meters supported

EM4900 models are all factory-configured as all 3-phase meters (w/o neutral). They can be easily re-configured to any combination of 1-ph, 2-ph, or 3-ph meters (with ION setup). Any unused channels can be used to measure neutral current. Label overlays (to re-number CT connections) are provided for 1-ph/2-ph applications.

Commercial ref. no.	EM4900 multi-circuit meters
METSEEM4904A	Multi-circuit meter — (4) 3-phase meters — Modbus RTU only
METSEEM4908A	Multi-circuit meter — (8) 3-phase meters — Modbus RTU only
METSEEM4914A	Multi-circuit meter — (14) 3-phase meters — Modbus RTU only
METSEEM4928A	Multi-circuit meter — (28) 3-phase meters — Modbus RTU only
METSEEM4904E	Multi-circuit meter — (4) 3-phase meters — Ethernet and serial (Modbus, BACnet, and SNMP)
METSEEM4908E	Multi-circuit meter — (8) 3-phase meters — Ethernet and serial (Modbus, BACnet, and SNMP)
METSEEM4914E	Multi-circuit meter — (14) 3-phase meters — Ethernet and serial (Modbus, BACnet, and SNMP)
METSEEM4928E	Multi-circuit meter — (28) 3-phase meters — Ethernet and serial (Modbus, BACnet, and SNMP)

MULTI-CIRCUIT METERING

# PowerLogic EM4900 series

## Functions and characteristics (cont.)



Flat ribbon cable



Round ribbon cable



PowerLogic™ LVCT0xxxS split-core low-voltage (1/3V) CTs are ideal for retrofit applications



PowerLogic™ LVCT2xxxS low-voltage (1/3V) solid core CTs are ideal for panel builders (small, medium, large)

### EM4900 series accessories

Commercial reference number	Description
BCPMCOVERS	EM4900 circuit board cover
E8951	Modbus to BACnet protocol converter

### Ribbon cables for 28-meter models

1.22 m cables are standard — others must be ordered separately

CBL008	Flat ribbon cable (quantity 1) for BCPM, length = 0.45 m
CBL016	Flat ribbon cable (quantity 1) for BCPM, length = 1.2 m
CBL017	Flat ribbon cable (quantity 1) for BCPM, length = 1.5 m
CBL018	Flat ribbon cable (quantity 1) for BCPM, length = 1.8 m
CBL019	Flat ribbon cable (quantity 1) for BCPM, length = 2.4 m
CBL020	Flat ribbon cable (quantity 1) for BCPM, length = 3.0 m
CBL021	Flat ribbon cable (quantity 1) for BCPM, length = 6.1 m
CBL022	Round ribbon cable (quantity 1) for BCPM, length = 1.2 m
CBL023	Round ribbon cable (quantity 1) for BCPM, length = 3 m
CBL024	Round ribbon cable (quantity 1) for BCPM, length = 6.1 m
CBL031	Round ribbon cable (quantity 1) for BCPM, length = 0.5 m
CBL033	Round ribbon cable (quantity 1) for BCPM, length = 0.8 m

### 1/3 V low-voltage split-core CTs

Commercial reference number	Amperage rating	Inside dimensions
LVCT00050S	50 A	10 x 11 mm
LVCT00101S	200 A	16 x 20 mm
LVCT00201S	200 A	32 x 32 mm
LVCT00102S	100 A	30 x 31 mm
LVCT00202S	200 A	30 x 31 mm
LVCT00302S	300 A	30 x 31 mm
LVCT00403S	400 A	62 x 73 mm
LVCT00603S	600 A	62 x 73 mm
LVCT00803S	800 A	62 x 73 mm
LVCT00804S	800 A	62 x 139 mm
LVCT01004S	1000 A	62 x 139 mm
LVCT01204S	1200 A	62 x 139 mm
LVCT01604S	1600 A	62 x 139 mm
LVCT02004S	2000 A	62 x 139 mm
LVCT02404S	2400 A	62 x 139 mm

### 1/3 V low-voltage solid-core CTs

Commercial reference number	Amperage rating	Inside dimensions
LVCT 20050S	50 A	10 mm
LVCT20100S	100 A	10 mm
LVCT20202S	200 A	25 mm
LVCT20403S	400 A	31 mm

MULTI-CIRCUIT METERING

# PowerLogic EM4900 series

## Dimensions and connection

EM49xxA main board dimensions

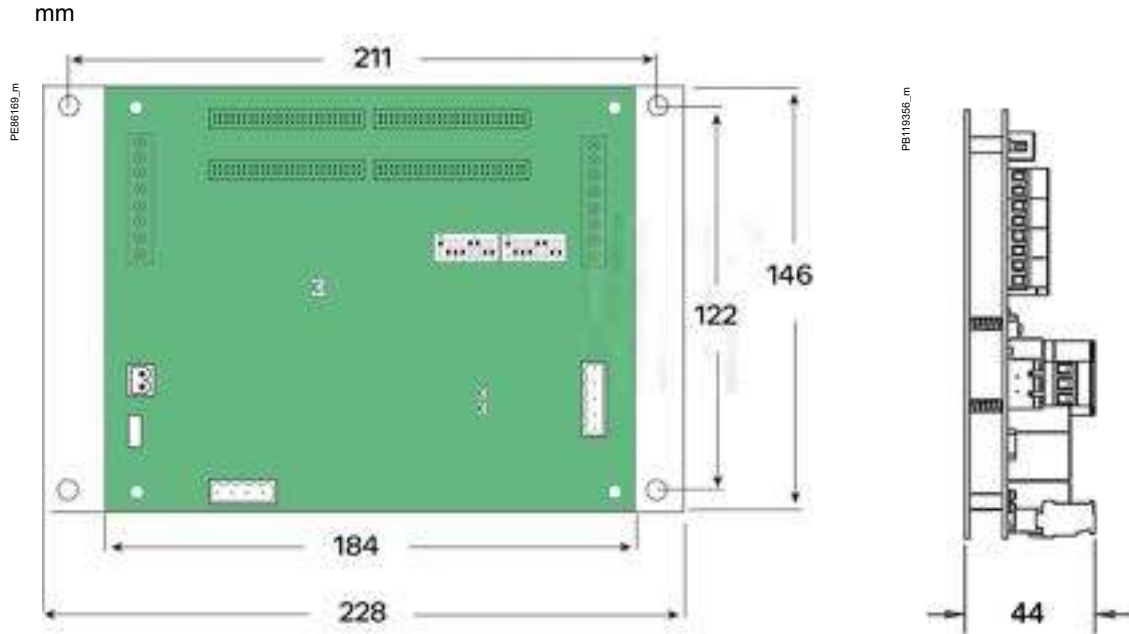

28-meter CT adapter assembly dimensions

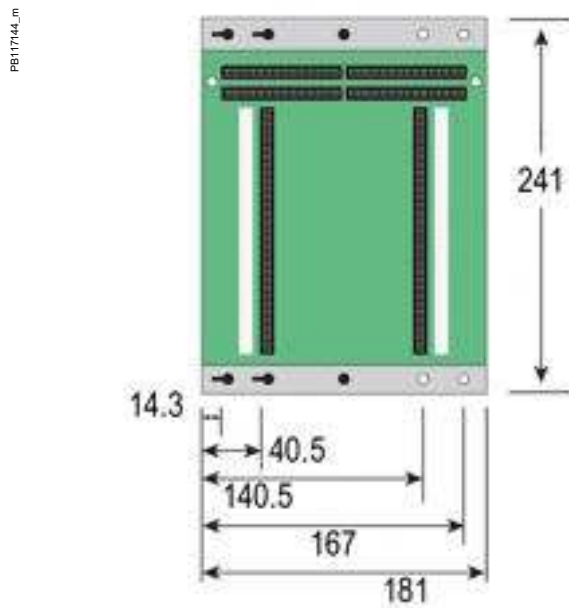

MULTI-CIRCUIT METERING

# PowerLogic EM4900 series

## Dimensions and connection (cont.)

### 50 A-200 A split-core CT dimensions

PB113659

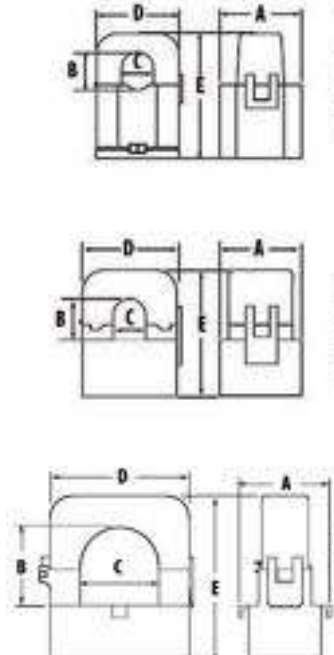

CT rating	A	B	C	D	E
50 A	26 mm	11 mm	10 mm	23 mm	40 mm
100 A	28 mm	16 mm	16 mm	40 mm	52 mm
200 A	37 mm	32 mm	32 mm	62 mm	69 mm

### Solid-core CT dimensions

PB113660

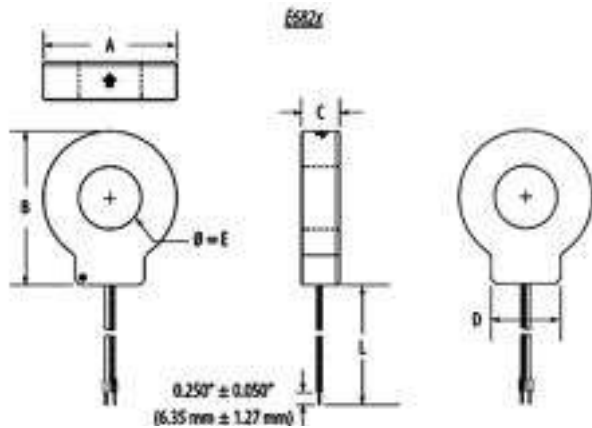

Model	L	A	B	C	D	E
LVCT200505	1.8 m	33 mm	38 mm	18 mm	21 mm	10 mm
LVCT201005		33 mm	38 mm	18 mm	21 mm	10 mm
LVCT202025	1.8 m	59 mm	66 mm	18 mm	31 mm	25 mm
LVCT204035	1.8 m	70 mm	82 mm	25 mm	36 mm	31 mm

### 1/3 V low-voltage CT form factor

PB113663

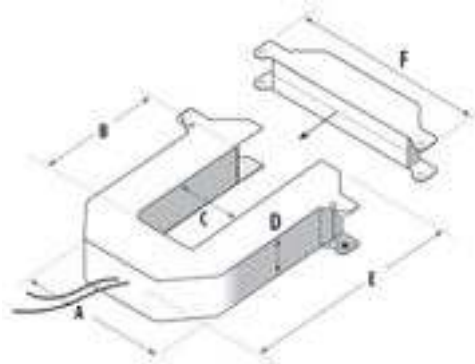

Small form factor 100/200/300 A	Medium form factor 400/600/800 A	Large form factor 800/1000/1200/ 1600/2000/2400 A
A = 96 mm	A = 125 mm	A = 125 mm
B = 30 mm	B = 73 mm	B = 139 mm
C = 31 mm	C = 62 mm	C = 62 mm
D = 30 mm	D = 30 mm	D = 30 mm
E = 100 mm	E = 132 mm	E = 201 mm
F = 121 mm	F = 151 mm	F = 151 mm

Split-core CT dimensions - see table.

MULTI-CIRCUIT METERING

# PowerLogic EM4000 series

The compact PowerLogic EM4000 series multi-circuit energy meter from Schneider Electric enables reliable monitoring of building electrical loads with a low installation cost-per-point by combining revenue-accurate electricity submetering with advanced communications technology.

## Applications

- Energy management
- Energy cost allocation
- Utility bill verification

PB113714

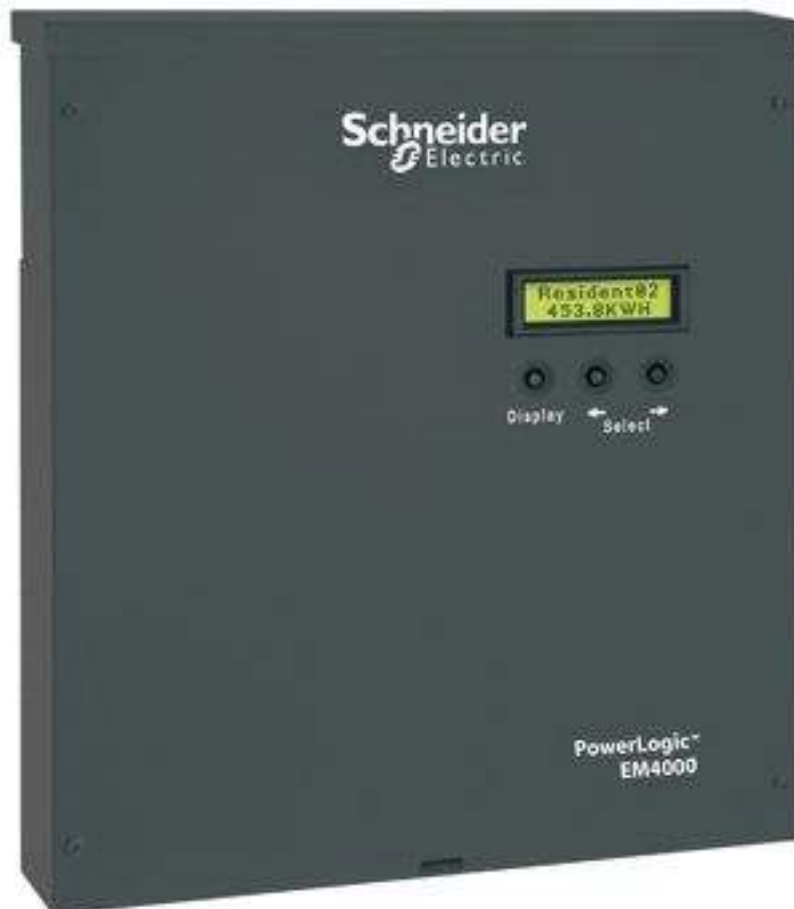

EM4000 series multi-circuit energy meter

MULTI-CIRCUIT METERING

The solution for

Markets that can benefit from a solution that includes EM4000 series meters:

- Buildings
- Multi-tenant facilities
- Healthcare
- Data centers

Benefits

- Improve energy efficiency
- Cost allocation
- Compact, maintenance-free design

Competitive advantages

- Compact energy-management solution
- Integrated communications

Conformity of standards

- IEC/EA/CSA 61010-1
- ICES-003 EN 55022
- IEC 6100-4-5
- CSA-C22.2 No 61010-1-04
- ANSI/TIA968-A: 2002

Main characteristics

- Compact, maintenance-free design
  - Requires no floor space
- Hi-density, flexible connection
  - From single-pole to single- or three-phase metering, supports up to 24 circuits
  - Select the connection type using an intuitive configuration tool
- Direct connection
  - For 100–300 V AC L-N electrical distribution systems
  - 120/240 V, 120/208 V, 277/480 V
- Multiple CT types
  - Support a variety of needs in both new and retrofit installations
  - 1/3 V output CT option does not require shorting blocks, making it the ideal choice for retrofit installations
- No rewiring required
  - Use existing wiring to connect to existing panels
- Integrated communications networks
  - Onboard Ethernet or RS-485 allows for easy integration into existing communications network

Part numbers

Model	Description	Commercial ref. no.
EM4033	24 x 333 mV inputs, 120 V control power 60 Hz	<b>METSEEM403316</b>
	24 x 333 mV inputs, 277 V control power 60 Hz	<b>METSEEM403336</b>
EM4080	24 x 80 mA inputs, 120 V control power 60 Hz	<b>METSEEM408016</b>
	24 x 80 mA inputs, 277 V control power 60 Hz	<b>METSEEM408036</b>

MULTI-CIRCUIT METERING

# PowerLogic EM4000 series

## Functions and characteristics (cont.)

The EM4000 is ideal for departmental metering applications and M&V within office towers, condominiums, apartment buildings, shopping centers, and other multi-user environments or small-footprint retail.

The PowerLogic EM4000 series meters monitor up to 24 meter points with a single device. Multiple meters can be combined to support an unlimited number of points.

Two meter models offer a choice of CTs and installation options:

- PowerLogic EM4033: 333 mV, split-core CTs
- PowerLogic EM4080: 80 mA, solid-core CTs

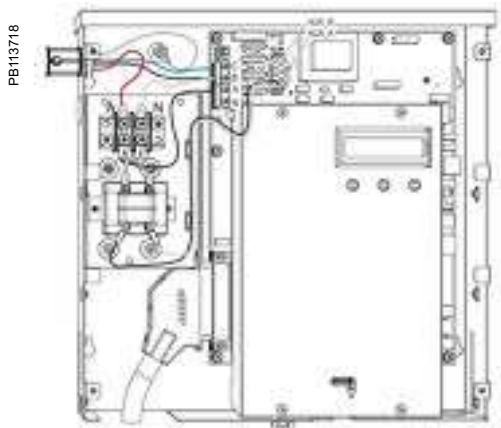

PowerLogic EM4000 meter 480Y/277V three-phase wye service connection

Selection guide		EM4033	EM4080
<b>General</b>			
Use on LV systems		■	■
Accuracy	+/- 0.5%	■	■
Accuracy compliance	ANSI C12.1 and C12.20 Class 0.5; IEC 62053-22, Class 0.5S	■	■
Maximum circuits: single-pole/single-phase/ three-phase	24/12/8	■	■
<b>Instantaneous RMS values</b>			
Energy	real, kWh received/delivered	■	■
	reactive, kvarh received/delivered	■	■
	apparent, VAh	■	■
Voltage		■	■
Pulse counts		■	■
Voltage and current	V RMS, I RMS per phase	■	■
Power	real, reactive, apparent	■	■
Power factor		■	■
<b>Measurements available for data logging</b>			
Energy	real, kWh received/delivered	■	■
	reactive, kvarh received/delivered	■	■
	apparent, VAh	■	■
Voltage		■	■
<b>Display</b>			
Backlit LCD display	2 lines of 16 characters	■	■
Optional remote modular display available		■	■
<b>Communication</b>			
Ethernet port		■	■
Modbus-RTU over RS-485		■	■
Pulse inputs	2	■	■
Protocols: Modbus TCP/IP, HTTP, BACnet/IP, FTP, and SNTP		■	■
<b>Installation options</b>			
0.333 V CTs		■	
80 mA CTs			■
Split-core CT		■	
Solid-core CT		■	■

# PowerLogic EM4000 series

## Functions and characteristics (cont.)

Technical specifications		
Input-voltage characteristics	Inputs	V1, V2, V3, Vn
	Measured voltage	80–480 V AC L-L without PTs Up to 999 kV with external PTs
	Frequency range	60 Hz
Mechanical characteristics		
Weight	EM4033/EM4080	Approx. 8.82 lb (4.0 kg)g
Dimensions	EM4033/EM4080	13.12 x 12.01 x 2.17 in (335 x 305 x 55 mm)
Environmental conditions		
Operating temperature		-40 °C to 70 °C
Storage temperature		-40 °C to 70 °C
Humidity rating		0% to 90% RH non-condensing
Enclosure		Type 1 (indoor or enclosed outdoor use)
Altitude		3000 m
Pollution degree		2
Safety and standards		
UL Certified to IEC/EA/CSA 61010-1		
CSA-C22.2 No 61010-1-04		
FCC Part 15 Class B		
ICES-003 EN 55022, IEC 6100-4-5		
ANSI/TIA968-A: 2002		
Communication		
Ports		Ethernet
		Modbus-RTU over RS-485
Pulse inputs		2
Protocols: Modbus TCP/IP, HTTP, BACnet/IP, FTP, and SNMP		
Display characteristics		
Integrated backlit LCD display		2 lines, 16 digits per line display R/L arrow buttons select metering point Display button cycles through measurements per point

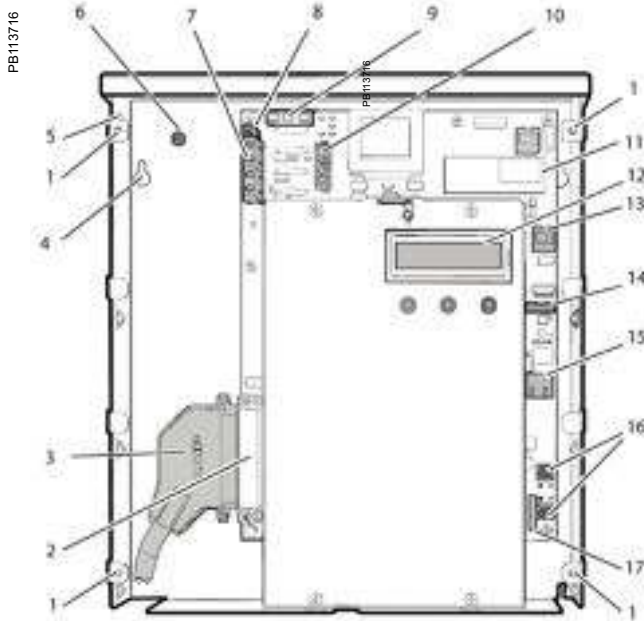

**Legend:**

- 1 Cover screw location
- 2 Meter point input connector
- 3 Cable connector
- 4 Mounting keyhole
- 5 Ingress punch-outs
- 6 Earth stud
- 7 Sense voltage terminal block
- 8 Control voltage terminal block
- 9 Fuse
- 10 Control voltage jumper
- 11 RTU interface
- 12 Display
- 13 Remote display connector
- 14 Serial RS-232
- 15 Ethernet port
- 16 Pulse in terminal blocks
- 17 Pulse out connector

PowerLogic EM4033 and PowerLogic EM4080 internal view

MULTI-CIRCUIT METERING

# PowerLogic EM4000 series

## Dimensions and connection

**EM4X00, CT termination, PT module**

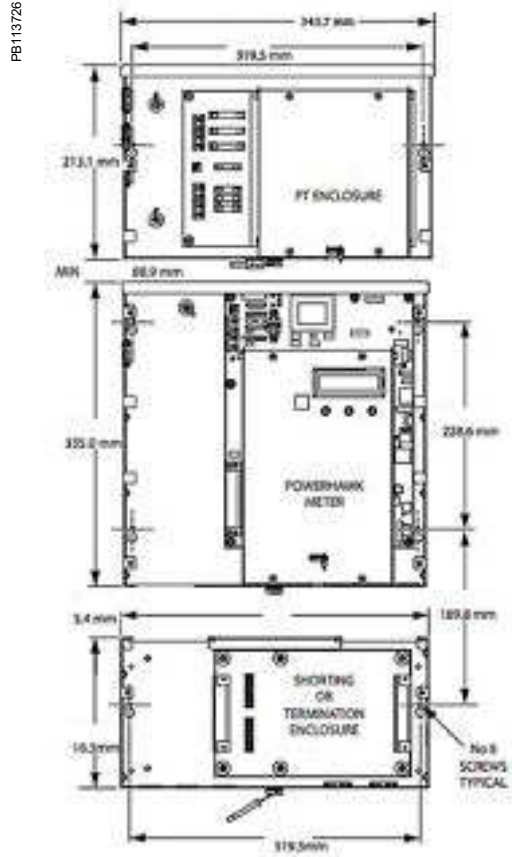

**EM4X00, CT termination, PT module**

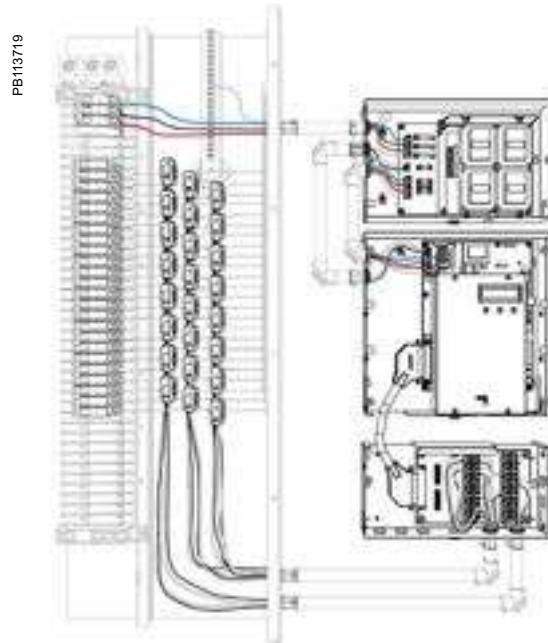

See appropriate Installation Guide for this product.

# PowerLogic EM4000 series

## Accessories



### PT module

The PT module provides step-down voltage connections to Schneider Electric PowerLogic meters for metering single-phase to three-phase voltages of 600 V, 347 V, or 400 V, while meeting all regulatory electrical safety and ANSI 0.5 Accuracy Class standards. The PT module provides both the per-phase input metering voltages and the auxiliary input power required by Schneider Electric PowerLogic energy meters.

There are two variants of the PT module that support the following source voltages and wiring configurations:

347 V wye/600 V delta-variant supports:

- 347 V, three-phase, 4-wire wye
- 600 V, three-phase, 3-wire delta

480 V delta variant supports:

- 480 V, three-phase, 3-wire delta

The 347 V/600 V PT module variant has three sense voltage potential transformers for metering. The configuration of the transformers (347 V wye or 600 V delta) is selected by using the jumper provided. The 480 V PT module has two sense-voltage potential transformers for metering. There is a separate auxiliary power transformer in both variants to operate the meter. All voltage inputs are fused.

PowerHawk PT module specifications			
Dimensions	Height	8.39 in (213.1 mm)	
	Width	2.13 in (54 mm)	
	Depth	2.13 in (54 mm)	
	Weight	12.5 lb (5.67 kg)	
Fuse ratings	High-voltage inputs	F1	T315 mA, 1000 V
		F2	T315 mA, 1000 V
		F3	T315 mA, 1000 V
	Voltage inputs	F4	T250 mA, 250 V
		F5	T250 mA, 250 V
		F6	T250 mA, 250 V
		F7	T250 mA, 250 V
Transformer specifications	Input voltage	600 V	Voltage tolerance: +/-10%
		480 V	Voltage tolerance: +/-10%
		347 V	Voltage tolerance: +/-10%
	Output voltage	120 V	Accuracy: 0.3%
Environmental	Operating temperature	-40 °C to 70 °C	
	Operating humidity	5% to 90% non-condensing	
	Usage environment	Indoor or enclosed outdoor environment	
	Maximum altitude	3000 m	
	Pollution degree	2	

Description	Commercial ref. no.
480 V PT module for EM4X00 meter	<b>METSEPTMOD480</b>
347 V/600 V PT module for EM4X00 meter	<b>METSEPTMOD347600</b>

MULTI-CIRCUIT METERING

# PowerLogic EM4000 series

## Accessories (cont.)

PB113725



### CT module

PowerLogic 4080 meters have two shorting options that provide a seamless and sealable mechanical package. The CT shorting module provides CT connections via the color-coded 25 pair cable routed into the breaker panel. All CTs are shorted at the same time for safe removal of the meter for maintenance when the electrical circuits are still live.

The CT termination module has the same shorting ability, but provides CT connections via 24 2-position screw-down terminal blocks. Individual pairs are then routed from the CT termination module to one or more breaker panels via conduit knockouts provided on the module, thus eliminating the need for a splitter box to route CT cables to multiple panels.

Description	Commercial ref. no.
CT termination module for EM4X00 meter	<b>METSECTTERM</b>
CT shorting module for EM4X00 meter	<b>METSECTSHORT</b>

PB113729

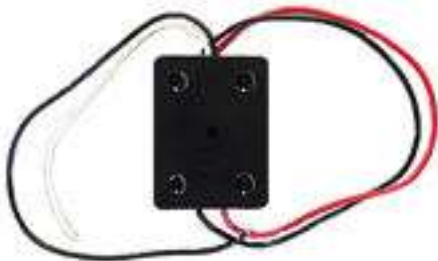

### Converter

The 5 A:80 mA converter is useful in applications where there are existing 5 A CTs integrated into large motors or switch gears. The 5 A:80 mA converter matches the 5 A secondary of the load to the 80 mA input of the meter. In billing grade applications, the 5 A:80 mA converter is also used to connect regulatory-grade large-aperture, large-amperage CT's with 5 A secondaries to the 80 mA of PowerLogic 4X80 meters.

Description	Commercial ref. no.
5 A : 80 mA converter for EM4X00 meter	<b>METSECONV580</b>

PB111056

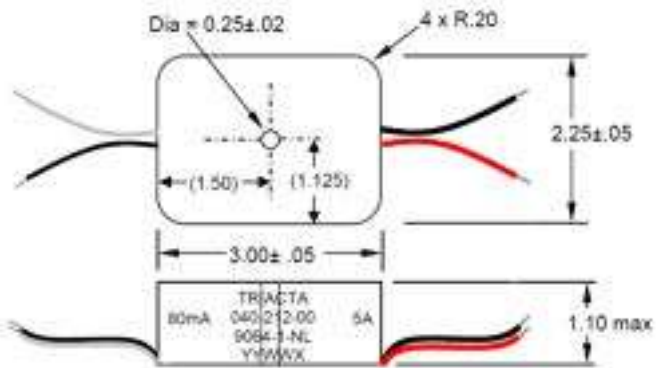

The 5 A to 80 mA converter dimensions

See appropriate Installation Guide for this product.

MULTI-CIRCUIT METERING

# PowerLogic EM4000 series

## Accessories and dimensions (cont.)

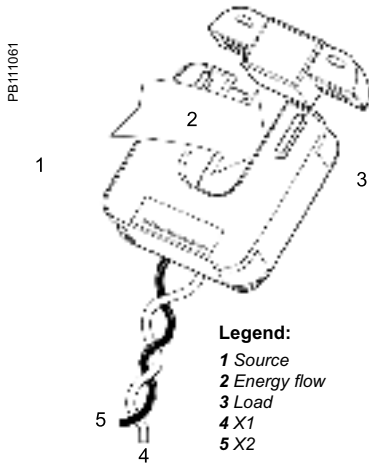

PowerLogic EM4033 split-core 0.333V current transformer

### CTs

- Model 8 (80/100 mA Secondary)
- Window size: 3.25 in (82.5 mm) diameters
- Application: metering
- Frequency: 50-400 Hz
- Insulation level: 600 volts, 10 Kv BIL full wave
- Flexible leads available for all case configurations; flexible leads are UL 1015 105°C, CSA approved #16 AWG, and 24 in (609.6 mm) long standard length; non-standard lengths are available upon request
- Terminals are brass studs (No. 8-32 UNC) with one flat washer, one lock washer, and one nut each; terminals are only available on the square case configuration
- Mounting-bracket kits for the model 8SHT are available when required
- Approximate weight: 3 lb (1.36 kg)

Description	Commercial ref. no.
CT, solid-core, 200 A primary, 80 mA secondary, for use with EM4X80 multi-circuit meter	<b>METSECT80200</b>
CT, solid-core, 400 A primary, 80 mA secondary, for use with EM4X80 multi-circuit meter	<b>METSECT80400</b>
CT, solid-core, 600 A primary, 80 mA secondary, for use with EM4X80 multi-circuit meter	<b>METSECT80600</b>



200 A CT

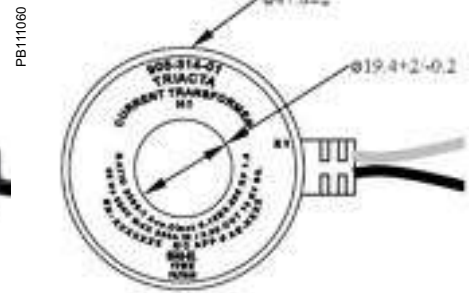

200 A CT dimensions



400 A CT

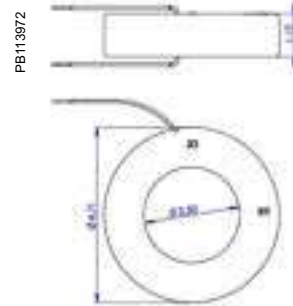

400 A CT dimensions



METSECT80600 600 A 80 mA CT

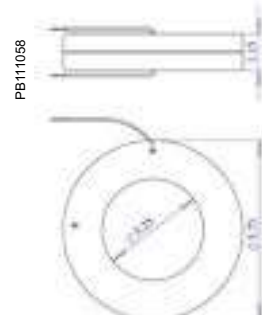

600 A 80 mA CT dimensions

## MULTI-CIRCUIT METERING

# PowerLogic EM4800 SERIES

The compact PowerLogic EM4800 series multi-circuit energy meter from Schneider Electric enables reliable metering of individual tenants with a low installation cost-per-point by combining revenue-accurate electricity submetering with advanced communications technology.

## Applications

- Multi-tenant metering
- Energy management
- Energy cost allocation
- Utility bill verification

PE66325

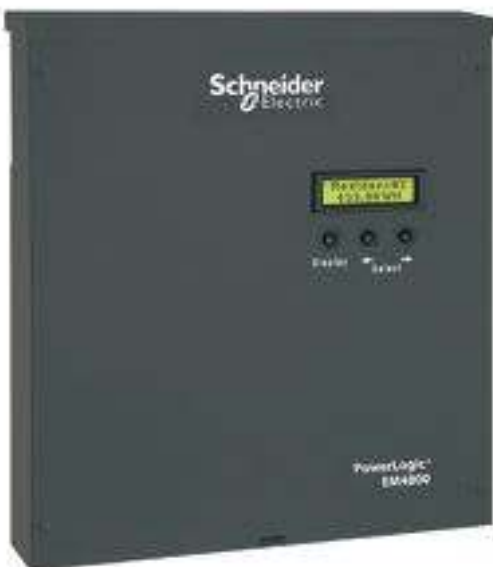

EM4800 series multi-circuit energy meter front (left),  
installed in panel (right)

## MULTI-CIRCUIT METERING

## The solution for

Markets that can benefit from a solution that includes EM4800 series meters:

- Buildings
- Multi-tenant facilities
- Healthcare

## Benefits

- Improve energy efficiency
- Cost allocation and tenant metering
- Compact, maintenance-free design

## Competitive advantages

- Compact energy-management solution
- Integrated communications

## Conformity of standards

- ANSI C12.1 and C12.20 Class 0.5
- IEC 62053-22, Class 0.5S
- IEC/EA/CSA 61010-1
- CSA-C22.2 No 61010-1-04
- ICES-003 EN55022
- IEC 6100-4-5
- ANSI/TIA968-A: 2002

PowerLogic EM4800 series meters monitor up to 24 tenants with a single device. Multiple meters can be combined to support an unlimited number of suites.

Three meter models offer a choice of CT secondary ratings and installation options:

- PowerLogic EM4805: 5 A, split- or solid-core CTs
- PowerLogic EM4833: 0.333 V, split- or solid-core CTs
- PowerLogic EM4880: 80 mA, solid-core CTs

## Main characteristics

- Compact, maintenance-free design
  - Requires no floor space
- Hi-density, flexible connection
  - From single-pole to single- or three-phase metering, supports up to 24 circuits. Select the connection type using an intuitive configuration tool
- Direct connection
  - For 100–300V AC L-N electrical distribution systems
  - 120/240 V, 120/208 V, 230/240 V, 220/380 V, 240/415 V, 277/480 V
- Multiple CT types
  - Support a variety of needs in both new and retrofit installations
  - 1/3 V output CT option does not require shorting blocks, making it the ideal choice for retrofit installations
- No rewiring required
  - Use existing wiring to connect to existing panels
- Integrated communications
  - Onboard Ethernet and modem allows for easy integration into existing communications networks

# PowerLogic EM4800 series

## Functions and characteristics (cont.)

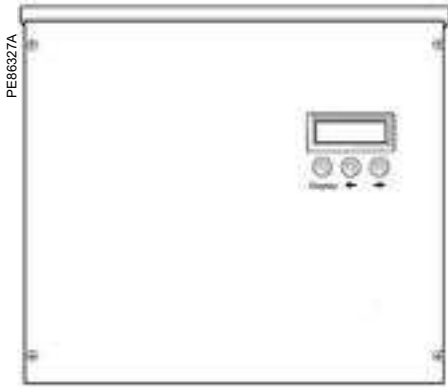

PowerLogic EM4800 series digital panel meter

Selection guide		EM4805	EM4833	EM4880
<b>General</b>				
Use on LV systems		■	■	■
Accuracy	+/- 0.5%	■	■	■
Accuracy compliance	ANSI C12.1 and C12.20 Class 0.5; IEC 62053-22, Class 0.5S	■	■	■
Maximum circuits: single-pole/single phase/ three-phase	24/12/8	■	■	■
<b>Instantaneous RMS values</b>				
Energy	Real, kWh received/delivered	■	■	■
	Reactive, kvarh received/ delivered	■	■	■
	Apparent, VAh	■	■	■
Voltage		■	■	■
Pulse counts		■	■	■
Voltage and current	V RMS, I RMS per phase	■	■	■
Power	real, reactive, apparent	■	■	■
Power factor		■	■	■
<b>Measurements available for data logging</b>				
Energy	Real, kWh received/delivered	■	■	■
	Reactive, kvarh received/ delivered	■	■	■
	Apparent, VAh	■	■	■
Voltage		■	■	■
<b>Display</b>				
Backlit LCD display	2 lines of 16 characters	■	■	■
Optional remote modular display available		■	■	■
<b>Communication</b>				
Ethernet port		■	■	■
V.90 modem port		■	■	■
Pulse inputs	2	■	■	■
Protocols: Modbus TCP/IP, HTTP, BACnet/IP, FTP, and SNTP		■	■	■
<b>Installation options</b>				
5 A CTs		■		
0.333 V CTs			■	
80 mA CTs				■
Split-core CT		■	■	
Solid-core CT		■	■	■
Remote modular display		■	■	■

### Commercial reference numbers

Model	Description	Commercial ref. no.
EM4805	24 x 5 A inputs, 230/240 V control power, 50 Hz	<b>METSEEM480525</b>
	24 x 5 A inputs, 120 V control power, 60 Hz	<b>METSEEM480516</b>
EM4833	24 x 333 mV inputs, 230/240 V control power, 50 Hz	<b>METSEEM483325</b>
	24 x 333 mV inputs, 120 V control power, 60 Hz	<b>METSEEM483316</b>
EM4880	24 x 80 mA inputs, 120 V control power, 60 Hz	<b>METSEEM488016</b>
	24 x 80 mA inputs, 230/240 V control power, 50 Hz	<b>METSEEM488025</b>

# PowerLogic EM4800 series

## Functions and characteristics (cont.)

Technical specifications		
Input-voltage characteristics	Inputs	V1, V2, V3, Vn
	Measured voltage	80 - 480 V AC L-L without PTs Up to 999 kV with external PTs
	Frequency range	50/60 Hz
Mechanical characteristics		
Weight	EM4805	Approx. 11.91 lb (5.4 kg)
	EM4833/EM4880	Approx. 8.82 lb (4.0 kg)
Dimensions	EM4805	13.19 x 1.73 x 2.17 in (335 x 44 x 55 mm)
	EM4833/EM4880	13.19 x 12.01 x 2.17 in (335 x 305 x 55 mm)
Environmental conditions		
Operating temperature	-40 °C to 70 °C	
Storage temperature	-40 °C to 70 °C	
Humidity rating	0% to 90% RH non-condensing	
Enclosure	Type 1 (indoor or enclosed outdoor use)	
Altitude	3000 m	
Pollution degree	2	
Safety and standards		
UL Certified to IEC/EA/CSA 61010-1		
CSA-C22.2 No. 61010-1-04		
FCC Part 15 Class B		
ICES-003 EN55022, IEC 6100-4-5		
ANSI/TIA968-A: 2002		
Communication		
Ports	Ethernet	
	V.90 modem	
Pulse inputs	2	
Protocols: Modbus TCP/IP, HTTP, BACnet/IP, FTP, and SNMP		
Display characteristics		
Integrated backlit LCD display	2 lines, 16 digits per line display; R/L arrow buttons select metering point; display button cycles through measurements per point	

# Communications



# Applications

This is a part of your metering solution which provides an interface between energy-monitoring software and your metering points via GPRS, wired connection and WiFi. We also offer the option of an integrated gateway-server which provides all-in-one energy-management solutions. They are fully capable of supporting EcoStruxure Power Monitoring software.

# Product overview

## Communications

Data loggers, gateways, and remote terminal units help measured data reach the power-monitoring software for analysis.

They are fundamental components in most power- and energy-management system architectures.

- Gateway Link150
- Data logger Com'X 210
- Data logger Com'X 510
- ION7550 RTU

COMMUNICATIONS

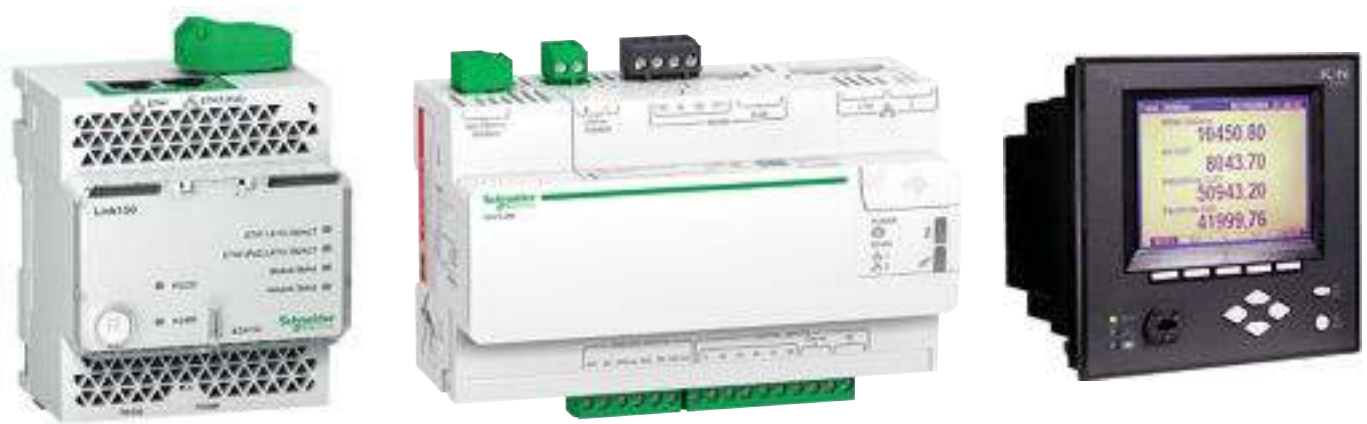

COMMUNICATIONS

# Serial link

With communication technology, it is no longer necessary to be physically present at the site to access information. Data is transmitted by networks.

In all architectures, the communication interface serves as the link between the installation devices and the PC running the operating software. It provides the physical link and protocol adaptation. Adaptation is required because the communication systems used by the PC (Modbus via RS232 and/or Ethernet) are generally not those used by the installation devices (e.g., the Modbus protocol via RS485).

Dedicated application software prepares the information for analysis under the best possible conditions.

In addition, a Modbus-Ethernet gateway in serial port slave mode allows a serial Modbus master device to access information from other devices across a Modbus TCP/IP network.

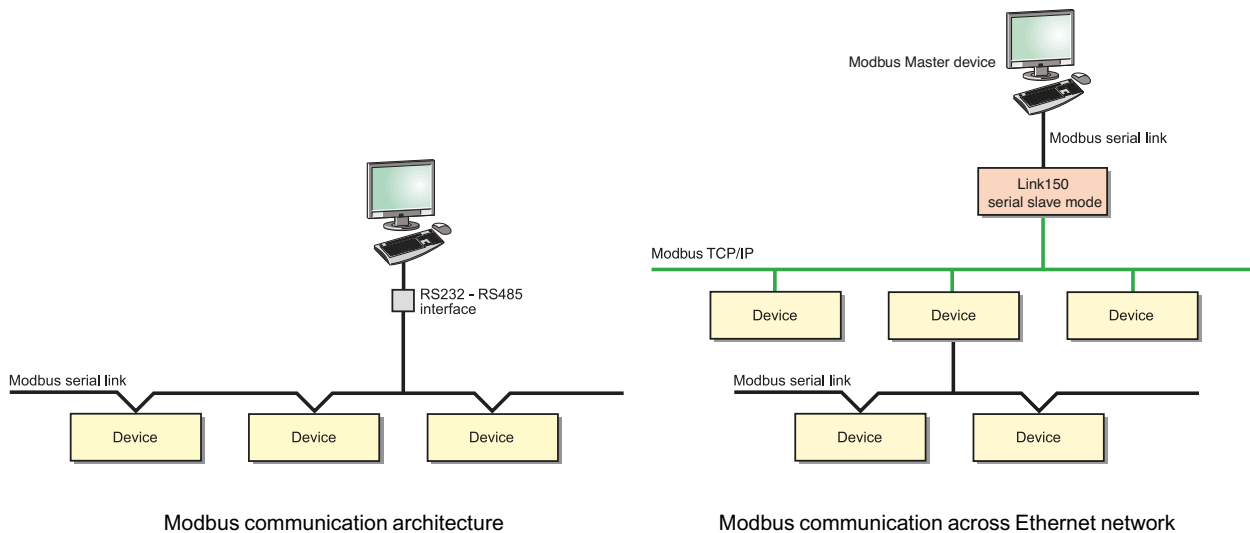

Switchboard-data acquisition and monitoring make it possible to anticipate events. In this way, they reduce customer costs in terms of operation, maintenance and investment.

COMMUNICATIONS

# Ethernet link

Using modern Web technologies, the operator can access information from monitoring and protection devices using any PC connected to the network, with all the required security.

The Ethernet Modbus-Ethernet gateway or the integrated gateway-servers provide connectivity between Modbus RS485 and Ethernet Modbus TCP/IP.

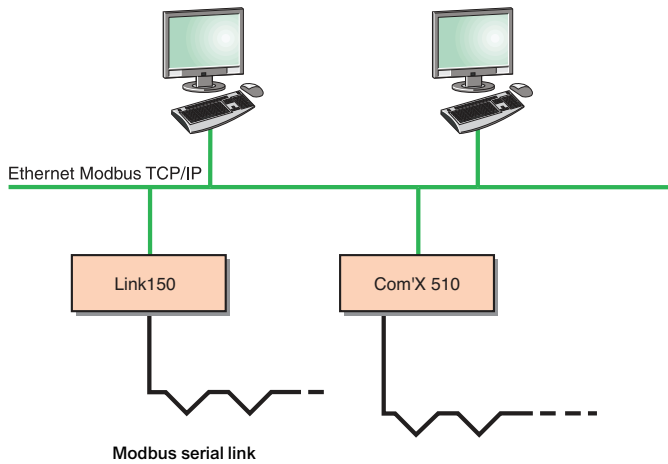

Ethernet communication architecture

The services available with these technologies considerably simplify the creation, maintenance, and operation of these supervision systems.

The application software is now standardized: the web interface into the system does not require custom web pages to be created. It is personalized by simply identifying the components in your installation and can be used as easily as any internet application.

The first step in this approach is the integrated gateway-server with HTTP pages. Power management software (EcoStruxure Power Monitoring Expert and EcoStruxure Power SCADA Operation), running on a PC, provide broader coverage for more specific needs.

## COMMUNICATIONS

# Link150 Ethernet gateway

The Link150 gateway provides fast, reliable Ethernet connectivity in the most demanding applications, from a single building to a multi-site enterprise. This gateway supports meters, monitors, protective relays, trip units, motor controls, and other devices that need to communicate data quickly and efficiently. It's your simple, cost-effective serial line to full Ethernet connectivity.

## Applications:

- Energy management
- Power distribution
- Building automation
- Factory automation



COMMUNICATIONS

The solution for

All markets that can benefit from a solution that includes the Link150 gateway:

- Buildings
- Data centers
- Healthcare
- Industry
- Infrastructure
- Utility

Benefits

- Easy to install and set up
- Easy to maintain
- Advanced security feature
- Compatible with Schneider Electric software offerings
- Reliable Modbus to Ethernet protocol conversion

Energy and power management software

Powerlogic software is recommended as a user interface, which provides access to all status and measurement information. It also prepares summary reports for energy and power management. *(Please see page 207.)*  
The Link150 is compatible with:

- EcoStruxure Power Monitoring Expert software
- EcoStruxure Power SCADA Operation

Conformity of standards

- EN55022/EN55011/ FCC Class A
- EN 61000-4-5
- EN 61000-4-6
- EN 61000-6-2
- EN 61000-4-8
- EN 61000-4-2
- EN 60950
- EN 61000-4-3
- EN 61000-4-4

Architecture

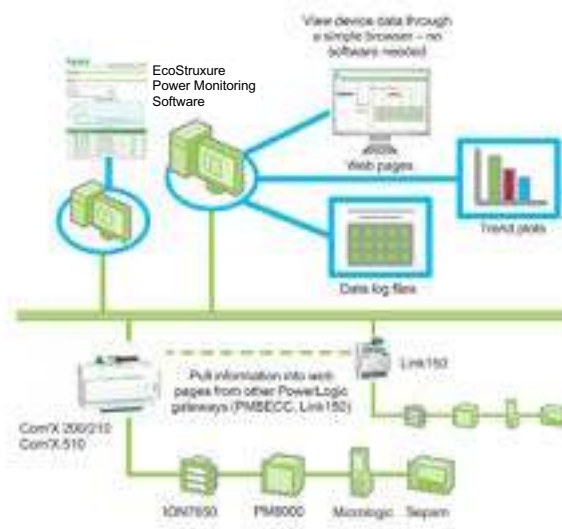

Security

- Secure user interface including user's name and password for login
- Advanced security features to allow users to specify which Modbus TCP/IP master devices may access attached serial slave devices
- Modbus TCP/IP filtering feature
- Allows user to specify the level of access for each master device as read-only or full access
- Web pages provide easy configuration and setup

Commercial reference numbers

Powerlogic Link150	Commercial ref. no.
Link150	EGX150
Modbus 3M cable RJ45 to free wires	VW3A8306D30

Contact your Schneider Electric representative for complete ordering information.

COMMUNICATIONS

# Link150

## Ethernet gateway

PB115132



Link150 front view

Characteristics	Link150
Weight	175 g without packing
Dimensions (HxWxD)	2.83 x 4.13 x 2.80 in (72 x 105 x 71 mm)
Mounting	DIN rail
Power-over-Ethernet (PoE)	Class 3
Power supply	24 V DC (-20/+10%) or Power-over-Ethernet (PoE Class 3 IEEE 802.3 af) at 15 W
Consumption (typical)	24 V DC, 130 mA at 20 °C PoE 48 V DC, 65 mA at 20 °C
Ambient operating temperature	-25 °C to 70 °C
Ambient storage temperature	-40 °C to 85 °C
Humidity rating	5% to 95% relative humidity (without condensation) at +55 °C
Pollution degree	Level 2
IP ratings	On the front panel (wall-mounted enclosure): IP4x Connectors: IP20 Other parts: IP30

### Regulatory/standards compliance for electromagnetic interference

Emissions (radiated and conducted)	EN 55022/EN 55011/FCC Class A
Immunity for industrial environments:	
Electrostatic discharge	EN 61000-6-2
Radiated RF	EN 61000-4-2
Electrical fast transients	EN 61000-4-3
Surge	EN 61000-4-4
Conducted RF	EN 61000-4-5
Power frequency	EN 61000-4-6
Magnetic field	EN 61000-4-8

### Regulatory/standards compliance for safety

Safety — IEC	IEC 60950
Safety — UL *	UL 60950 UL 61010-2-201
EMC	IEC 6100-6-2
Australia	C-tick – RCM
Sustainability	Green premium

### Serial ports

Number of ports	2 (1 available at a time)
Types of ports	RS-232 or RS-485 (2-wire or 4-wire), depending on settings
Protocol	Modbus, serial
Baud rates	19200 bps (factory setting), 2400 bps, 4800 bps, 9600 bps, 38400 bps, 56000 bps**, 57600 bps**
Maximum number of connected devices	32 (directly) 247 (indirectly)

### Ethernet ports (used as a switch)

Number of ports	2
Type of port	10/100BASE-TX (802.3af) port
Protocol	HTTP, Modbus TCP/IP, FTP, SNMP (MIB II)

\* Dual listed for U.S. and Canada

\*\* Only available when physical interface is set to RS-232 and transmission mode is set to Modbus ASCII

COMMUNICATIONS

# Link150

## Ethernet gateway

### Parts

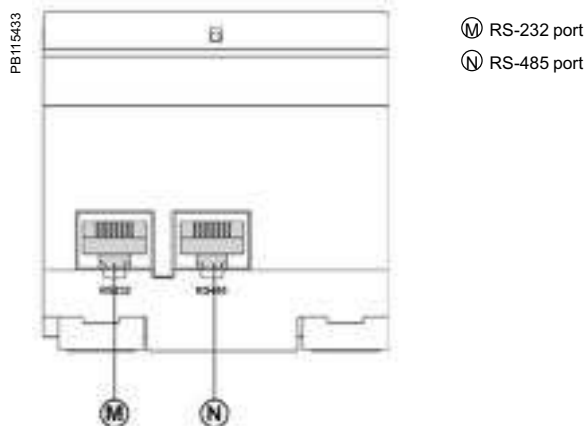
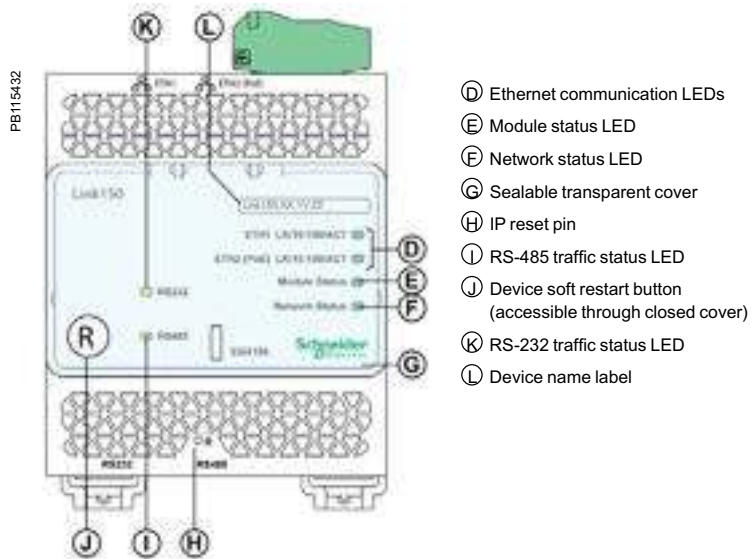
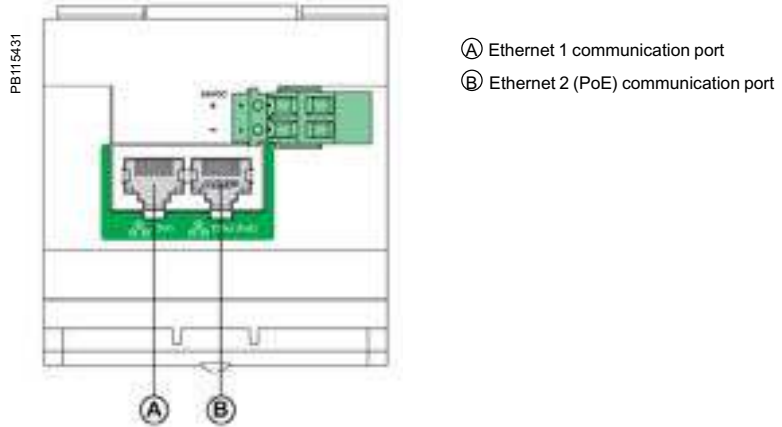

COMMUNICATIONS

# Link150

## Ethernet gateway

### Dimensions

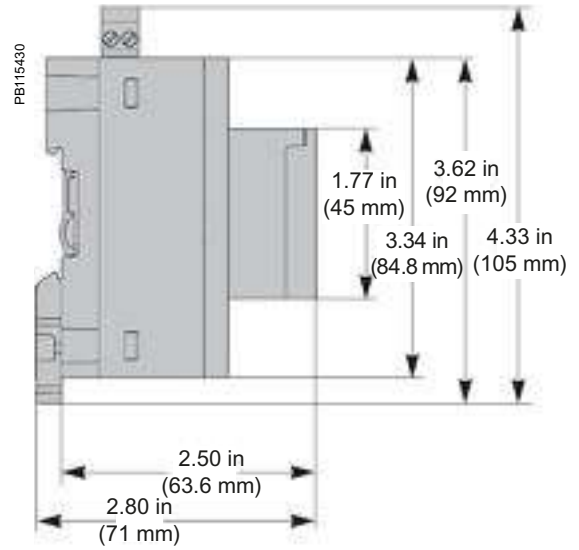

### DIN rail mounting

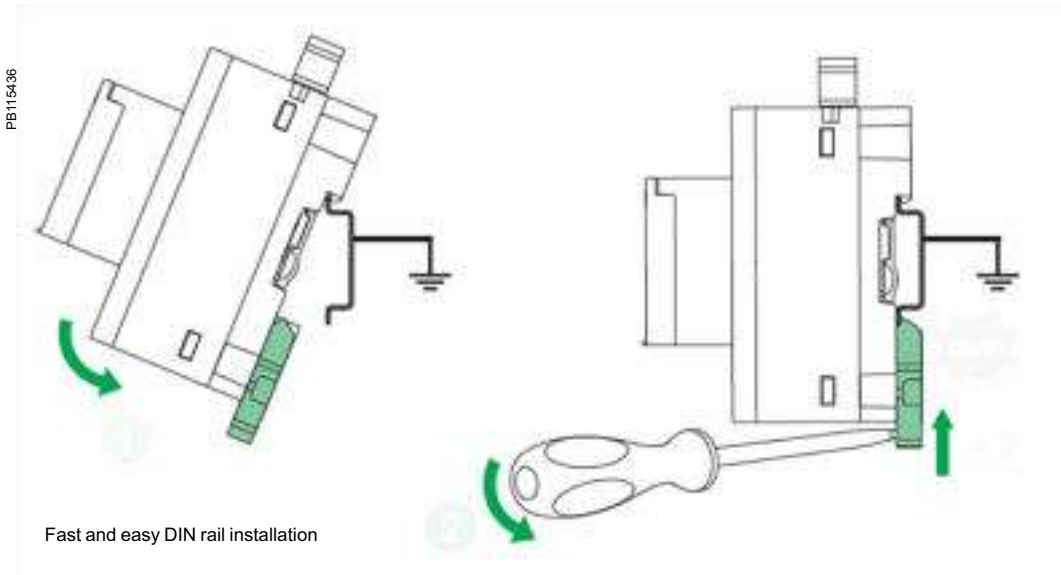

See appropriate Installation Guide for this product.

## COMMUNICATIONS

# Com'X 210

A highly flexible plug-and-play Energy Server Com'X 210 collects and stores WAGES consumptions and environmental parameters such as temperatures, humidity, and CO2 levels in a building. Data is periodically transmitted as a report to an internet database server for further processing. The Energy Server Com'X 210 not only reduces your technical complexity, it also helps manage your energy.

## Applications:

The quickest path to multi-site energy management and online services:

- Delivers batches of data ready to process by EcoStruxure solutions and services
- Publishes logged data to the Schneider Electric cloud or another hosted platform

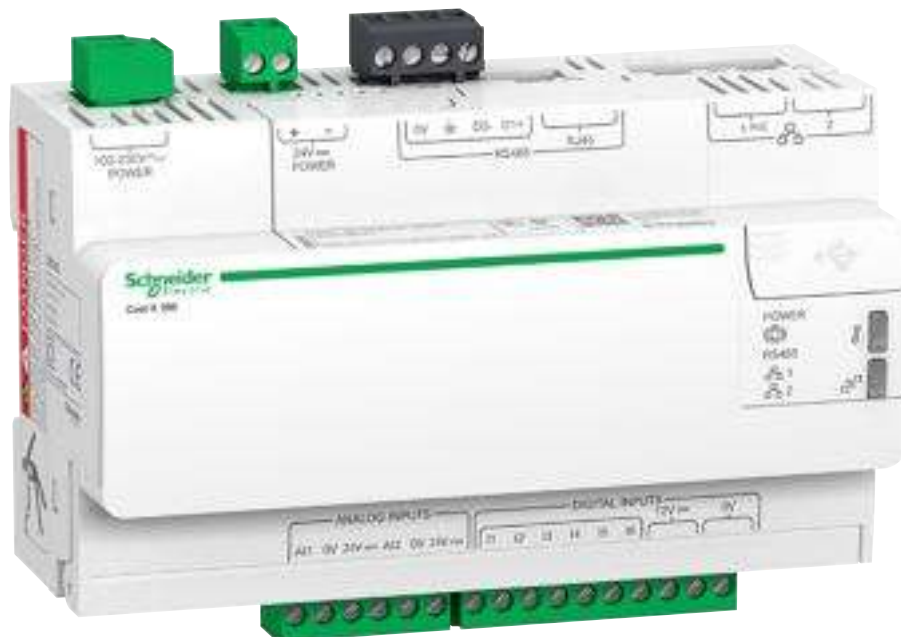

## COMMUNICATIONS

### The solution for

Markets that can benefit from a solution that includes data logger Com'X 210:

- Buildings
  - Industry
- 

### Benefits

- Data collection from up to 64 field devices
- Data publishing leveraging existing infrastructures, Ethernet or WiFi, GPRS-ready
- Quick fitting into electrical switchboards thanks to DIN rail clipping and profile
- Quick setup and configuration thanks to intuitive HMI

### Energy-management solutions

The data collected and stored by Com'X 210 can be processed and displayed as web pages through web services provided by Schneider Electric, such as EcoStruxure Energy Operation or by any private energy platform.

The Com'X 210 also provides a transparent interface between Ethernet-based networks and field devices. This gateway function supports the use of monitoring software, such as Power Monitoring Expert (PME) for data collection, trending, event management, analysis, and further processing.

---

### Conformity of standards

- EN60950

COMMUNICATIONS



Energy dashboard comparing accumulated over time energy values (partial screen)

Data collector

As soon as they are connected to the LAN, it can be detected and assigned an IP address by DHCP. Your operating system's DPWS feature allows your computer to automatically recognize the device as Com'X. Embedded web pages are then immediately accessible by clicking each Com'X device icon or by typing the assigned IP address into your web browser.

Collects and stores energy data from up to 64 field devices, connected to either:

- Ethernet TCP/IP field network
- Modbus serial line network (up to 32 devices)
- Embedded digital and analog inputs

"Field devices" consist of

- PowerLogic meters for power and energy monitoring
- Masterpact, powerpact, or compact circuit breakers for protection and monitoring
- Acti 9 protection devices, meters, remote controlled switches, etc.
- Water, air, gas, electricity, and steam consumption meters, from specialized manufacturers, delivering pulses as per standard
- Environmental sensors such as temperatures, humidity, and CO<sub>2</sub> levels in a building, providing analog information

Data-logging and storage capabilities include:

- Data-logging period, configurable from every minute to once a week
- Data-storage duration of up to two years, depending on quantity of collected data
- Ability to set time and send reset instructions to field devices

Embedded energy-management software

The Com'X provides the end-user with immediate visibility into energy consumption throughout the site. As soon as the Com'X is connected to the Local Area Network (LAN), several web pages are accessible via any standard web browser (without plug-in or additional components).

These web pages display real-time data as it is collected, in easy-to-understand tabular and summary formats. In addition, users can get simple analysis of historical data in bar graph or trending formats.

Com'X 210 commercial reference numbers	
Com'X 210 data logger 24 V DC power supplied UL rated	<b>EBX210</b>
Com'X Wi-Fi USB interface	<b>EBXA-USB-WiFi</b>
Com'X GPRS interface with SIM card for RSP only	<b>EBXA-GPRS-SIM</b>
Com'X GPRS interface	<b>EBXA-GPRS</b>
Com'X external GPRS antenna	<b>EBXA-ANT-5M</b>
Com'X Zigbee USB interface	<b>EBXA-USB-Zigbee</b>

Please see your Schneider Electric representative for complete ordering information.

## COMMUNICATIONS

# Com'X 510

A highly flexible plug-and-play Energy Server Com'X 510 collects and stores WAGES consumptions and environmental parameters such as temperatures, humidity, and CO<sub>2</sub> levels in a building. The Com'X 510 has up to two years of data storage and embedded web pages, which means all your energy data can be viewed and managed on-site.

### Applications:

- All-in-one-box energy-management solution especially suitable for buildings up to 10,000 sq. meters

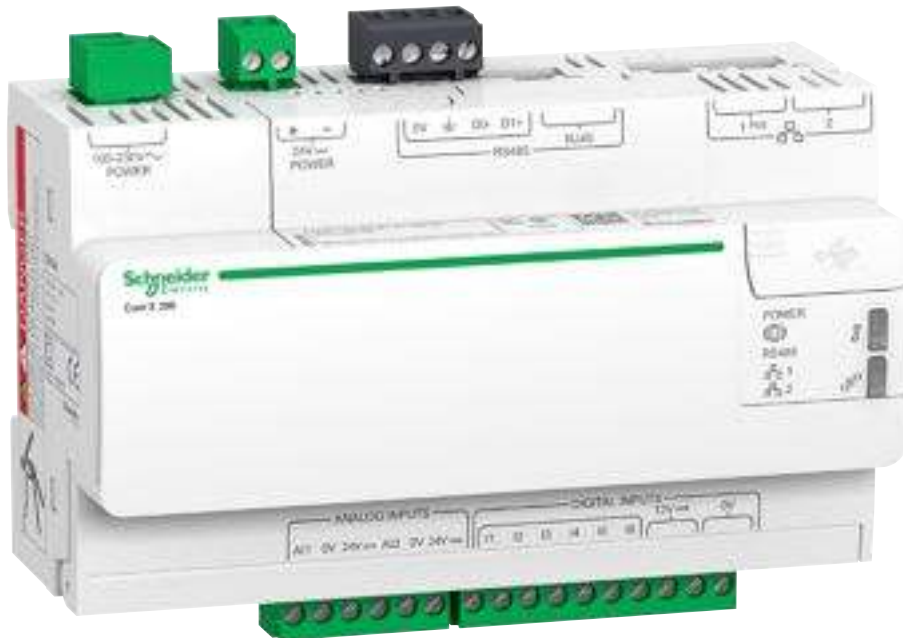

## COMMUNICATIONS

### The solution for

Markets that can benefit from a solution that includes data logger Com'X 510:

- Buildings
  - Industry
- 

### Benefits

- Data collection from up to 64 field devices
  - Data publishing leveraging existing infrastructures: Ethernet or Wi-Fi, GPRS-ready
  - Quick fitting into electrical switchboards thanks to DIN rail clipping and profile
  - Quick setup and configuration thanks to intuitive HMI
- 

### Competitive advantages

- Fit any PDU or RPP design for both new and retrofit projects
- Class 1.0 system accuracy
- Ethernet communication

### Energy management solution

The data collected and stored by Com'X 510 can be processed and displayed through its own onboard web page.

The Com'X 510 also provides a transparent interface between Ethernet-based networks and field devices. This gateway function supports the use of monitoring software, such as Power Monitoring Expert (PME) for data collection, trending, event management, analysis, and further processing.

---

### Conformity of standards

- EN60950

COMMUNICATIONS



Energy Server Com'X 510 data logger



Raw data and measurements from one field device (partial screen)



Historical trending comparing multiple devices or multiple topics (partial screen)

Additional functions

Data publisher

Batches of collected data can also be periodically transmitted to an Internet server as:

- XML files, for processing by EcoStruxure web services, such as Energy Operation
- CSV files for viewing in Excel or transformed and uploaded to programs such as EcoStruxure Power Monitoring Expert, or any compatible software

Data publishing function supports four transfer protocols over Ethernet or WiFi:

- HTTP
- HTTPS
- FTP
- SMTP

Gateway

- If selected by the user, the Com'X 510 can make data from connected devices available in real time
- In Modbus TCP/IP format over Ethernet or Wi-Fi
- For requests by energy-management software
- Gateway to Zigbee device data by external Modbus TCP/IP clients

Modbus packets can be sent from managing software to field devices through Modbus serial line or Modbus TCP/IP over Ethernet.

- Real-time trending
- Custom web page support

Com'X 510 commercial reference numbers	
Com'X 510 energy server 24 V DC power supplied UL rated	<b>EBX510</b>
Com'X Wi-Fi USB interface	<b>EBXA-USB-WiFi</b>
Com'X GPRS interface SIM card	<b>EBXA-GPRS-SIM</b>
Com'X GPRS interface	<b>EBXA-GPRS</b>
Com'X External GPRS antenna	<b>EBXA-ANT-5M</b>
Com'X Zigbee USB interface	<b>EBXA-USB-Zigbee</b>

*Please see your Schneider Electric representative for complete ordering information.*

COMMUNICATIONS

# Com'X 210/510 Connectivity



**Connection points**

- 1 Terminal block
- 2 RJ45 cable
- 3 Ethernet port #1
- 4 Ethernet port #2



Power supply to analog and digital inputs



WiFi USB stick



GPRS modem



GPRS antenna

**Connectivity**

Modbus SL/RS-485 connections to field devices

- By cable with RJ45 connector

2 Ethernet ports

- Used to either separate upstream connection from field devices network or to daisy chain Ethernet devices
- RJ45 10/100BASE connectors
- Static IP address

Ethernet port #1

- Connection to local area network (LAN).
- PoE Class 3 (802.3af) can act as main/backup power supply for the Com'X
- DHCP client

Ethernet port #2

- Connection to field devices
- DHCP client or server

Power supply to analog and digital outputs

- Outputs to supply sensors and inputs when Com'X is supplied through 24 V DC input on top
- 12 V DC 60 mA for digital inputs
- 24 V DC for analog inputs
- Compliant with electrical switchboard environment (temperature, electromagnetic compatibility)

Two inputs for analog sensors

PT100 or PT1000 temperature probes

- Various sensors (humidity, CO2, etc.) with 0-10 V output
- Various sensors with 4-20 mA output

Six inputs for dry contact sensors or pulse counters

- Max 25 pulses per second (min duration 20 ms)
- IEC 62053-31 Class A

Wi-Fi USB stick

- As an alternative to publication over Ethernet, connects Com'X to the site WiFi router for regular data transmission
- Can also be used for Com'X 510 configuration through one-to-one connection with laptop or tablet
- Simply plugs into USB port 2 under front cover

GPRS/3G modem

- For connection to the data processing server through cellular or user's APN network
- Also connect to Schneider Electric's Digital Service Platform
- Especially suitable for sites with no Internet access
- Simply plugs into dedicated port under the front cover

GPRS antenna

- Improves GPRS signal strength in case of poor transmission conditions
- Recommended for Com'X located inside metallic electrical panels

Zigbee dongle (not shown)

- For connection to wireless digital-enabled field devices
- Plugs into USB ports

# Com'X 210/510

## Setup and configuration



*Device settings page (partial), as displayed after auto-discovery, enabling user to assign circuit identifications and select data for logging and publication.*

### Installation

- DIN rail fitting (Front face IP40, terminals IP20)
- Weight 1 lb (450 g)
- Dimensions (H x W x D) 3.58 x 5.67 x 2.59 in (91 x 144 x 65.8 mm)

### Setup and configuration

#### Connection to LAN

As soon as the data loggers are connected to the LAN, they can be detected and assigned an IP address by DHCP. Your operating system's DPWS feature allows your computer to automatically recognize the device as Com'X. Embedded web pages are then immediately accessible by clicking each Com'X device icon or by typing the assigned IP address into your web browser.

#### Field device auto-discovery

The user-activated device discovery function automatically identifies all field devices connected to Modbus SL, Ethernet port, or Zigbee dongle.

- Known Schneider Electric devices display with the product image.
- Other devices appear as "unknown," allowing the user to manually assign a device type
- Users can assign their own device types
- Users can complete additional device identification fields, such as circuit ID or building zone

#### Custom library available for unknown field devices

- Ability to create your own custom model based upon Modbus RTU/TCP, pulse, sensor, etc.
- Log data from the custom model
- Export/import the custom model into other Com'X devices

#### Data selection for logging and publication

Web page configuration tabs allow you to configure, in just a few clicks, which connected field devices collect and publish data.

#### Advanced diagnostics and troubleshooting features

- Modbus serial and TCP/IP device statistics
- Ethernet network statistics
- Communications check wizard
- Direct reading of register values from local and remote devices

### Additional features and benefits

- Cybersecurity — works well with your cybersecurity architecture
- Two Ethernet ports to separate upstream cloud connection, or to daisy chain with other Ethernet devices, from field device network
- Data storage in case of communications failure
- Local backup of configuration parameters — back up your system to a USB storage device and have it available for system restore or to duplicate the configuration on another box

#### When associated with Schneider Electric Services:

- Remotely managed (configuration backup, troubleshooting, parameter setting)
- GPRS SIM contract management (with EBXA-GPRS-SIM)

COMMUNICATIONS

# Com'X 210/510 Specifications

Com'X 210/510 environment	
Operating temperature	-25 °C to 70 °C Com'X 210/510
Storage temperature	-40 °C to 85 °C
GPRS dongle Operating temperature	-20 °C to 60 °C
GPRS dongle Storage temperature	-40 °C to 85 °C
WiFi dongle Operating temperature	0 °C to 50 °C
WiFi dongle Storage temperature	-20 °C to 80 °C
Humidity	5% to 95% relative humidity (without condensation) at 55 °C
Pollution	Class III

Safety standards/regulation	
International (CB scheme)	IEC 60950
U.S.	UL 508
U.S.	UL 60950 (Com'X 210 and Com'X 510 only)
Canada	cUL 60950 (Com'X 210 and Com'X 510 only)
Canada	cULus 508
Europe	EN 60950

Quality Brands	
	CE, UL

Power Supply		Com'X 210	Com'X 510
AC	100 to 230 V (+/- 15%) (50-60 Hz)		
DC	24 V (+/- 10%)	■	■
Power over Ethernet	15.4 W DC	■	■
Max power	26 W max	■	■
Mechanical			
IP	Front face IP40, terminals IP20	■	■
Dimensions (HxWxD)	3.58 x 5.67 x 2.59 in (91 x 144 x 65.8 mm)	■	■
Weight	1 lb (450 g)	■	■

## COMMUNICATIONS

# ION7550 RTU

The PowerLogic ION7550 RTU (remote terminal unit) is an intelligent web-enabled device ideal for combined utilities metering of water, air, gas, electricity, and steam (WAGES). When combined with power management software, the ION7550 RTU offers a seamless, end-to-end WAGES metering solution.

Featuring a large, high-visibility display and overall versatility of the PowerLogic system, the ION7550 RTU provides extensive analog and digital I/O choices, and is a cost-effective dedicated WAGES solution when compared to a traditional meter. The device automatically collects, scales, and logs readings from a large number of connected meters or transducers, and delivers information to one or more head-end systems through a unique combination of integrated Ethernet, modem, or serial gateways.

### Applications:

- WAGES (water, air, gas, electricity, steam) metering
- Integrated utility metering with advanced programmable math functions
- Data concentration through multi-port, multi-protocol communications
- Equipment status monitoring and control
- Programmable set points for out-of-limit triggers or alarm conditions



## COMMUNICATIONS

### The solution for

Markets that can benefit from a solution that includes PowerLogic ION7550RTU series meters:

- Buildings
- Industry
- Healthcare
- Education

### Benefits

- Help reduce waste and optimize equipment operation to increase energy efficiency
- A large, intuitive display
- Extensive digital and analog I/O
- Dedicated WAGES solution when compared to a traditional meter

### Competitive advantages

- Data concentration through multi-port, multi-protocol communications
- Integrated utility metering with advanced programmable function

### Conformity of standards

- EN 61010-1
- IEC 61000-4-2
- IEC 61000-4-3
- IEC 61000-4-4
- IEC 61000-4-5
- CISPR 22

### Main characteristics

- Increase efficiency
  - Reduce waste and optimize equipment operation to increase efficiency
- Easy to operate
  - Screen-based menu system to configure meter settings and bright LCD display with adjustable contrast
- Integrate with software
  - Easily integrated with PowerLogic or other energy-management enterprises, including SCADA systems
- Transducer and equipment condition monitoring
  - Versatile communications, extensive I/O points, clock synchronization, event logging, and sequence of events recording capabilities for transducer and equipment condition and status monitoring at utility substations
- Set automatic alarms
  - Alarm setpoint learning feature for optimum threshold settings
- Up to 10 MB of memory
  - For archiving of data and waveforms
- Notification alarms via email
  - High-priority alarms sent directly to the user's PC, and instant notification of power quality events by email
- Modbus Master functionality
  - Aggregate and store data from downstream Modbus devices using serial or Ethernet connections

# ION7550 RTU

## Functions and characteristics (cont.)

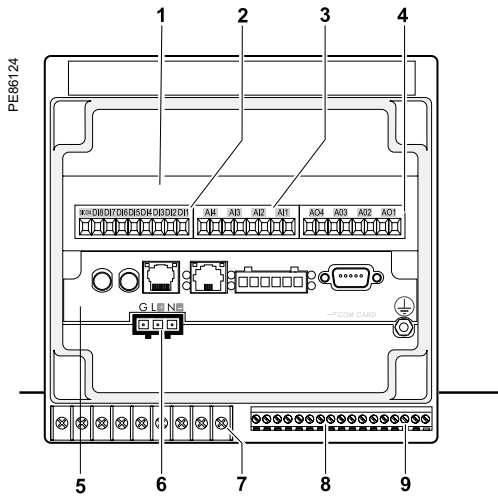

### Selection guide ION7550 RTU

Data recording	
Min/max of instantaneous values	■
Data logs	■
Event logs	■
Trending	■
SER (sequence of event recording)	■
Timestamping	■
GPS synchronization (1 ms)	■
Memory (in MB)	10 MB

Display and I/O	
Front-panel display	■
Pulse output	1
Digital or analog inputs (max)	24
Digital or analog outputs (max, including pulse output)	30

### Electrical characteristics

Data update rate	1/2 cycle or 1 second	
Power supply	AC	85 to 240 V AC ±10% (47-63 Hz)
	DC	110 to 300 V DC ±10%
	DC low voltage (optional)	20 to 60 V DC ±10%
	Ride-through time	100 ms (6 cycles at 60 Hz) min at 120 V DC
	Burden	Standard: typical 15 VA, max 35 VA Low voltage DC: typical 12 VA, max 18 VA
Input/outputs *	Standard	8 digital inputs (120 V DC) 3 relay outputs (250 V AC/30 V DC) 4 digital outputs (solid state)
	Optional	8 additional digital inputs 4 analog outputs, and/or 4 analog inputs

### Mechanical characteristics

Weight	4.19 lb (1.9 kg)	
IP degree of protection (IEC 60529)	IP52	
Dimensions	Standard model	7.56 x 7.56 x 6.26 in (192 x 192 x 159 mm)
	TRAN model	9.27 x 8.52 x 5.24 in (235.5 x 216.3 x 133.1 mm)

### Environmental conditions

Operating temperature	Standard power supply	-20 °C to 70 °C
	Low-voltage DC supply	-20 °C to 50 °C
	Display operating range	-20 °C to 70 °C
Storage temperature	Display, TRAN	-40 °C to 85 °C
Humidity rating	5% to 95% non-condensing	
Installation category	III 2000m above sea level	
Dielectric withstand	As per EN 61010-1, IEC 62051-22A **	

### Electromagnetic compatibility

Electrostatic discharge	IEC 61000-4-2
Immunity to radiated fields	IEC 61000-4-3
Immunity to fast transients	IEC 61000-4-4
Immunity to surges	IEC 61000-4-5
Conducted and radiated emissions	CISPR 22

### Safety

Europe	IEC 61010-1
--------	-------------

\* Consult the ION7550/ION7650 Installation Guide for complete specifications.

\*\* IEC 62051-22B with serial ports only.

### Commercial reference number

ION7550 RTU	Comm. ref. no.
ION7550	M7550

# ION7550 RTU

## Functions and characteristics (cont.)

Communication	
RS-232/RS-485 port *	Up to 115,200 baud (57,600 baud for RS-485), ION, DNP 3.0, Modbus, GPS, EtherGate, ModemGate, Modbus Master
RS-485 port *	Up to 115,200 baud, ION, DNP 3.0, Modbus, GPS, EtherGate, ModemGate, Modbus Master
Infrared port *	ANSI type 2, up to 19,200 baud, ION, Modbus, DNP 3.0
Ethernet port	10BASE-T, 100Base-TX RJ45 connector, 10/100 m link
Fiber-optic Ethernet link	100BASE-FX, SC duplex connector, 1300 nm, FO multimode with gradient index 62.5/125 µm or 50/125 µm, 2000 m link
Protocol	ION, Modbus, Modbus Master, TCP/IP, DNP 3.0, Telnet
EtherGate	Communicates directly with up to 62 slave devices via available serial ports
ModemGate	Internal modem, communicates directly with up to 31 slave devices
WebMeter	5 customizable pages, new page creation capabilities, HTML/XML compatible
Firmware characteristics	
High-speed data recording	Down to 5ms interval-burst recording, stores detailed characteristics of disturbances or outages; trigger recording by a user-defined setpoint, or from external equipment
Load profiling	Channel assignments (800 channels via 50 data recorders) are configurable for any measurable parameter; trigger recorders based on time interval, calendar schedule, alarm/event condition, or manually
Trend curves	Access historical data at the front panel; display, trend and continuously update historical data with date and timestamps for up to four parameters simultaneously
Alarms	Threshold alarms: - Adjustable pickup and dropout setpoints and time delays, numerous activation levels possible for a given type of alarm user-defined priority levels - Boolean combination of alarms is possible using the operators NAND, OR, NOR, and XOR
Advanced security	Up to 16 users with unique access rights; perform resets, time syncs, or meter configurations based on user privileges
Memory	5 MB to 10 MB (specified at time of order)
Firmware update	Update via the communication ports
Display characteristics	
Integrated display	Backlit LCD, configurable screens
Languages	English

\* All communication ports may be used simultaneously.

# ION7550 RTU

## Functions and characteristics (cont.)

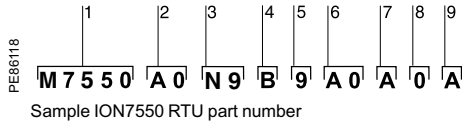

### Commercial reference numbers

Item	Code	Description
1 Model	7550	ION7550 device
2 Form factor	A0	Integrated display with front optical port, 5 MB logging memory, and 512 samples per cycle resolution
	B0	Integrated display with front optical port, 10 MB logging memory, and 512 samples per cycle resolution
	T0	Transducer (no display) version, with 5 MB logging memory
	U0	Transducer (no display) version, with 10 MB logging memory
3 RTU option	N9	RTU option
4 Power supply	B	Standard power supply (85-240 V AC, ±10%/47-63 Hz/110-330 V DC, ±10%)
	C	Low-voltage DC power supply (20-60 VDC)
5 Internal use	9	This field for internal use only
6 Communications	A0	Standard communications (1 RS-232/RS-485 port, 1 RS-485 port); integrated display models also include 1 ANSI type 2 optical communications port
	C1	Standard communications plus 10BASE-T/100BASE-TX Ethernet (RJ-45), 56k universal internal modem (RJ-11); Ethernet, modem gateway functions each use a serial port
	D7	Standard comms plus 10BASE-T/100BASE-TX Ethernet (RJ-45) and 100BASE-FX Ethernet Fiber, 56 k universal internal modem (RJ-11); Ethernet and modem gateway functions each use a serial communications port
	E0	Standard communications plus 10BASE-T/100BASE-TX Ethernet (RJ-45); Ethernet gateway function uses serial port
	F1	Standard communications plus 10BASE-T/100BASE-TX Ethernet (RJ-45); and 100BASE-FX (SC fiber-optic connection); Ethernet gateway uses a serial port
	M1	Standard communications plus 56 k universal internal modem (RJ-11); modem gateway uses serial communications port
	7 I/O	A
	E	Standard I/O plus expansion I/O card (eight additional digital inputs and four 0 to 20 mA analog inputs)
	K	Standard I/O plus expansion I/O card (eight additional digital inputs and four 0 to 20 mA analog outputs)
	N	Standard I/O plus expansion I/O card (eight additional digital inputs and four 0 to 20 mA analog inputs and four 0 to 20 mA outputs)
	P	Standard I/O plus expansion I/O card (eight additional digital inputs and four 0 to 1 analog inputs and four -1 to 1 mA analog outputs)
8 Security	0	Password protected, no hardware lock
9 Special order	A	None
	C	Tropicalization treatment applied

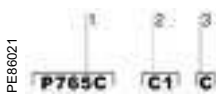

Example order code. Use this group of codes when ordering the PowerLogic ION7550 RTU communication or I/O card.

- 1 Communications or I/O card
- 2 Type
- 3 Special order

### Communications Card

Item	Code	Description
1 Comm card	P765C	ION7550 RTU communication card for field retrofit installations
2 Type	A0	Standard communications (1 RS-232/RS-485 port, 1 RS-485 port); front optical port support for meters with integrated display
	C1	Standard communications plus 10BASE-T/100BASE-TX Ethernet (RJ-45), 56 k universal internal modem (RJ-11); the modem port is shared with the front optical port; Ethernet and modem gateway functions each use a serial communications port.
	D7	Standard communications plus 10BASE-T/100BASE-TX Ethernet, 100BASE-FX Ethernet Fiber, 56k universal internal modem (RJ-11); the modem port is shared with the front optical port; Ethernet and modem gateway functions each use a serial communications port
	E0	Standard communications plus 10BASE-T/100BASE-TX Ethernet; Ethernet gateway function uses a serial communications port
	F1	Standard communications plus 10BASE-T/100BASE-TX Ethernet, 100BASE-FX Ethernet Fiber (SC fiber-optic connection); Ethernet gateway function uses a serial communications port
	M1	Standard communications plus 56 k universal internal modem (RJ-11); the modem port is shared with the front optical port) Modem gateway function uses a serial communications port
3 Special order	A	None
	C	Tropicalization treatment applied

# ION7550 RTU

## Functions and characteristics (cont.)

Commercial reference numbers (cont'd)		
Input/output expansion card		
Item	Code	Description
I/O card	P760A	Expansion I/O for field retrofit installations
	E	Expansion I/O card with eight digital inputs, four 0 to 20 mA analog inputs
	K	Expansion I/O card with eight digital inputs, four 0 to 20 mA analog outputs
	N	Expansion I/O card with eight digital inputs, four 0 to 20 mA analog inputs and four 0 to 20 mA outputs
	P	Expansion I/O card with eight digital inputs, four 0 to 1 analog inputs and four -1 to 1 mA analog outputs
Special order	A	None
	C	Tropicalization treatment applied

## Dimensions and connection

### ION7550 RTU dimensions

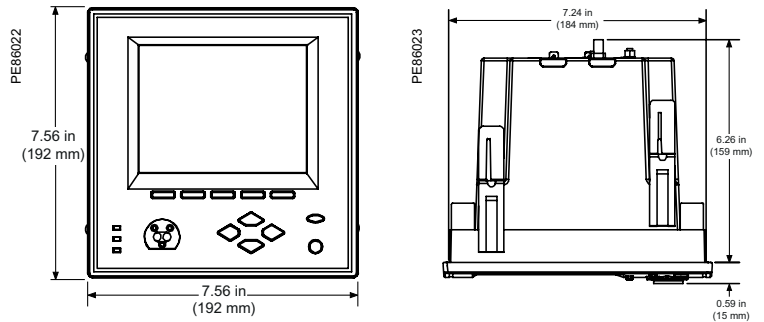

### Front-panel mounting

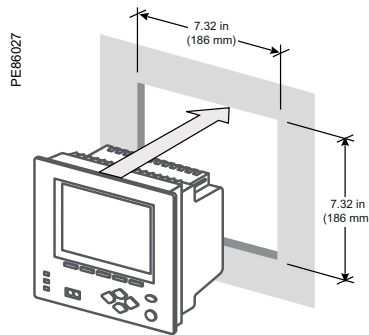

### Power supply

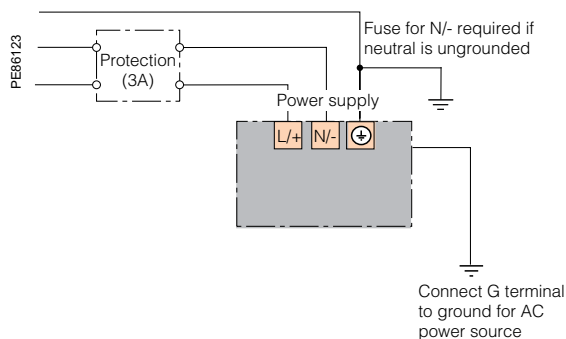

Note: the current and voltage terminal strip (I52, I51, I42, I41, I32, I31, I22, I21, I12, I11, V4, V3, V2, V1, Vref) is not present on the RTU.

See appropriate *Installation Guide* for this product.

# Monitoring software





## A choice of powerful, effective solutions

EcoStruxure power management software provides a complete power-management supervisory interface that gives you access to your entire electrical network from anywhere. The software converts energy-related data into timely, accurate information for you to act on.

Track real-time power conditions, analyze power quality and reliability, and respond quickly to alarms to avoid critical situations. Our power-management software provides extensive analysis and reporting tools, intuitive visualization and control interfaces, and flexible, scalable architectures that can meet your unique needs today and continue to do so well into the future. The depth of different offerings makes it easy to match a product to your goals, your business, and your budget.

### Extensive reach and flexibility

Software forms an important part of your overall energy efficiency and reliability solutions from Schneider Electric. Power management software can grow with your business, giving you the level of energy intelligence and control you need to reduce energy consumption and costs, minimize environmental impacts, prolong equipment life, and assure power availability, uptime, and safety.

Each product collects energy-related data from a variety of sources, including PowerLogic or third-party meters and sensors. Some products offer integration with other Schneider Electric or third-party automation systems, and other energy-relevant information feeds.

### System requirements

Whether you're building a new system or enhancing an existing operation, a Schneider Electric representative will advise you on complete system requirements and commissioning information for EcoStruxure power management software.

## Power management software

EcoStruxure Power Monitoring Expert is an operations-level supervisory software that provides a complete power-management solution for industry, large commercial and institutional buildings, data centers, healthcare facilities, and utilities.

Engineering and management personnel can cut energy-related costs, avoid downtime, and optimize equipment operations by using the information provided by EcoStruxure Power Monitoring software.

EcoStruxure Power Monitoring Expert also enables tracking of real-time power conditions, analysis of power quality and reliability, and quick response to alarms to avoid critical situations. The software forms a layer of energy intelligence across your facility, campus, or service area, acting as a unified interface to all electrical and piped utilities.



EcoStruxure Power SCADA Operation is a reliable, flexible, and high-performance monitoring and control solution designed to reduce outages and increase power efficiency.



It's built to handle user requirements from the smallest to the most demanding enterprises, while still providing high-time performance and reliability. Easy-to-use configuration tools and powerful features enable faster development and deployment of applications of any size.

Object-based standard graphics and symbols provide operators with an interactive and user-friendly interface. Intuitive commands and controls increase efficiency of operators to interact with the system interface. EcoStruxure Power SCADA Operation controls your system with high reliability, performance, and data integrity through the use of advanced architectures, such as hot/warm redundant I/O device configurations, self-healing ring communications, and primary and standby server configurations. Comprehensive user-based security is integrated into all interface elements, ensuring a secure control system.

### The solution for

Markets that can benefit from a solution that includes power-management software:

- Buildings
- Data centers
- Healthcare
- Industry
- Infrastructure
- Utility

Category	Application
 Energy efficiency and cost	Energy usage analysis
	Cost allocation
	Procurement optimization
	Peak-demand reduction
	Demand response and curtailment
	Power factor correction
 Power availability and reliability	Electrical distribution (ED)
	Power quality analysis and compliance
	ED commissioning, monitoring, and troubleshooting
	ED alarming and events
 Asset management	Capacity planning
	Generator monitoring
	Breaker-aging management
	UPS battery monitoring



## Typical applications

EcoStruxure power management software has many applications:

- Monitor the facility electrical network and verify reliable operation
- Improve response to power-related events and restore operations quickly
- Analyze and isolate the source of power quality problems
- Analyze energy use to identify waste and reduce cost
- Estimate utility bills to verify accuracy and identify errors
- Allocate energy costs to departments to drive accountability and awareness
- Reduce peak-demand surcharges and power-factor penalties
- Identify excess capacity in existing infrastructure and avoid over-building
- Support proactive maintenance to prolong asset life
- Network protection and control
- Operate distribution network safely and reliably
- Improve continuity of electrical service
- Equipment monitoring and control
- Energy availability and reliability
- Verify the reliable operation of equipment
- Support proactive maintenance to prolong asset life

For electric utilities:

- Improve T&D network reliability
- Enhance substation automation
- Maximize the use of existing infrastructure
- Verify compliance with new power quality standards
- Analyze and isolate the source of power quality problems
- Help customers manage reliability using operational and power quality data

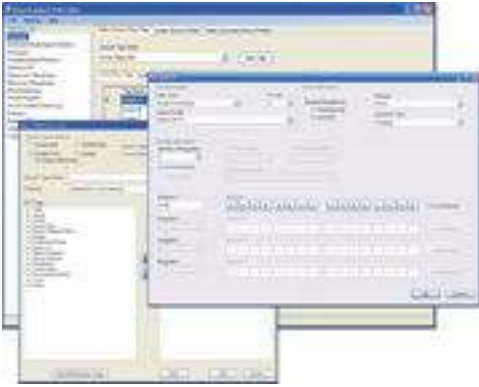

## Scalable, flexible architecture

### Functional components

Operators are provided with a rich environment in which to view and navigate real-time displays of measurements and status indicators, perform power quality and reliability analysis, historical trending, alarms, and manual control. This software offers secure, operator-dedicated, multi-user data and controls access through a local server interface, full control client, and also via web clients.

### Web clients

Access our power-monitoring system from anywhere on your network using a web browser and enjoy day-to-day functionality, including system status and alarm response, and dashboard viewing. Web client provides authenticated access to these common functions:

- Diagrams – navigate network displays to check system status and analyze trends
- Tables – quickly compare multiple devices in your network in real time
- Reports – generate or edit historical reports for energy cost, consumption, and power quality
- Alarms – quickly identify alarm states in your system and investigate root causes
- Dashboards – share information from your power-monitoring system with any occupant

### Engineering workstations

Client software gives engineers and power users access to administrative and configuration functions of the software, and real-time display, control, and historical analysis functions.

Build and edit custom graphical displays to represent your facility. One-line diagrams, campus maps, equipment plan views, and mimic diagrams are easily created using Vista graphical objects and imported graphic files.

Use the designer interface to program ION devices and create system applications with ION Technology and Virtual ION Processors Reporter — generate or edit historical reports for energy cost, consumption, and power quality.

### Data acquisition and management

- Communicate with over 300 different powerlog and third-party meters
- Scale from one device to thousands
- Perform advanced logic and arithmetic operations on real-time and historical data
- Use web services to interoperate and integrate with other software platforms

MONITORING SOFTWARE

# Functions

EcoStruxure power management software offers a wide range of functions:

- Data acquisition and integration
- Real-time monitoring
- Trend analysis
- Power quality analysis
- Alarms and events
- Reporting
- Dashboards
- Manual and automated control

## Data acquisition and integration

Integrate WAGES (water, air, gas, electricity, steam) metering. Native, out-of-the-box support for dozens of devices (see Supported devices section for details).

- Enables access to real-time and timestamped historical meter data, control of on-board relays and digital outputs, and server time synchronization
- Communicate over Internet, Ethernet, wireless
- Interface with third-party meters, transducers, PLCs, RTUs, and power distribution or mitigation equipment through Modbus or OPC
- Add and configure direct communications with remote devices over Modbus RTU or Modbus TCP protocols using easy-to-use device templates

The scalable platform enables remote device and user-client addition as needs grow while maintaining original investment. Integrate other energy-management or automation systems (e.g., SCADA, BAC, DCS, ERP) through ODBC, XML, OPC, email, FTP, CSV, and PQDIF compliance, or integrate with web services through XML.

## Real-time monitoring

View the status of your electrical network from any workstation:

- See numeric values, status indicators, gauges, and trends, all with intuitive graphical navigation
- Extend comprehensive, out-of-the-box displays and create custom graphical diagrams to represent your facility; one-line diagrams, campus maps, equipment plan views, and mimic diagrams can be created using embedded graphical objects and imported graphic files
- Quickly compare multiple devices in your network in real-time in a tabular display
- Choose from a library of pre-built tables, or create your own; save your favorites for quick access later

## Trend analysis

- Trend parameters to reveal demand peaks and track system-wide energy costs
- Graph any combination of measured parameters
- Plot time-series or scatter charts
- Perform calculations, obtain statistics, and display historical data
- Identify dangerous trends and redistribute loads
- Optimize network capacity and avoid over-building
- View operating parameters and determine when maintenance is required
- Avoid peak-demand surcharges and power-factor penalties

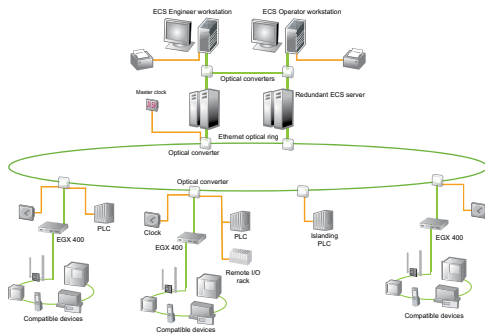

Consumption details by area and load type

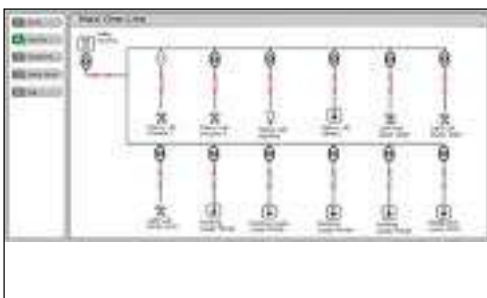

Equipment status example

MONITORING SOFTWARE

# Scalable, flexible architecture

## Power quality analysis

- EcoStruxure power management software allows continuous, wide-area monitoring and data capture for power quality and reliability conditions
- Power quality events automatically detected by PQ-capable metering devices are uploaded to the system automatically, and users can analyze waveforms to determine source and cause of issue
- Determine if power quality events are upstream or downstream (using PowerLogic meters with Disturbance Direction Detection feature)
- IEC 61000-4-30 and EN50160 compliance reporting verifies power quality performance to international standards and allows you to quickly review power quality indices as numeric charts or graphic profiles (using PowerLogic meters to support compliance monitoring)
- Display harmonic histograms, odd/even harmonics, THD, K-factor, crest factor, phasor diagrams, and symmetrical components
- Plot waveforms of up to many seconds in duration, with overlays that correlate phase-to-phase relationships between voltages, currents, and cascading failures
- Plot sags, swells, short-duration transients, and other disturbance events on industry-standard voltage tolerance curves, including ITIC (CBEMA) and SEMI
- Display for any event a list of associated timestamped incidents, then click on any incident to see more detailed information

## Alarms and events

Receive alerts to outages or impending problems that could lead to equipment stress, failures, or downtime.

- Quickly filter on active or unacknowledged alarms
- Acknowledge alarms from anywhere in your facility
- Trigger on complex conditions
- Log all relevant data sequence of events for diagnosis
- Flag and avert potential problems
- Alert key personnel 24/7
- Optimize maintenance scheduling
- Easily discriminate between alarm criticality levels
- High-speed alarm response
- Organize, filter, and print by any alarm property; configure specific alarm occurrences to change symbol color or flash an icon on a page
- View the five most recent alarms from every page, and receive detailed information in easy-to-understand formats
- Event log for all PC-based and on-board field events and alarms
- Easily configure to annunciate based on alarm type

## Dashboards

Create engaging dashboard displays of your power monitoring system information and easily share information with anyone in your facility

- Make power monitoring information visible and engaging
- Promote education and drive behavior
- Display as an interactive kiosk on corporate intranet or on wall-mounted display
- Replace hard to maintain home-grown portals and dashboards
- Chart or trend any quantity in your power monitoring database
- Simply convert into other units (e.g., dollars, emissions, normalizations, etc.)
- Compare multiple time-ranges
- Show impact of temperature, occupancy, or production values on energy usage
- Create eye-catching backgrounds to enhance presentation value
- User authentication for configuration, with both authenticated and unauthenticated modes available for display



Applications allow users to see costs of power quality issues

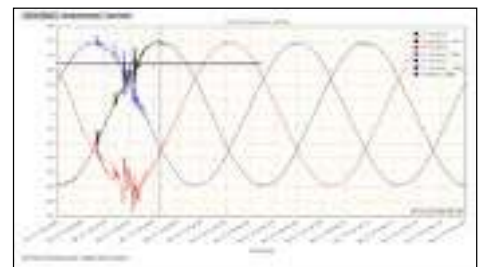

Users can view and analyze waveforms captured by devices

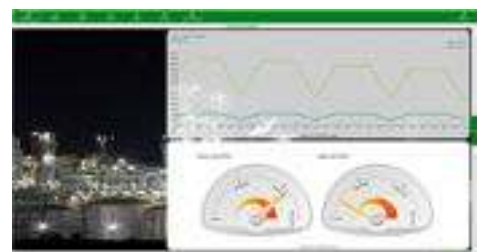

Load profile dashboard (sample)

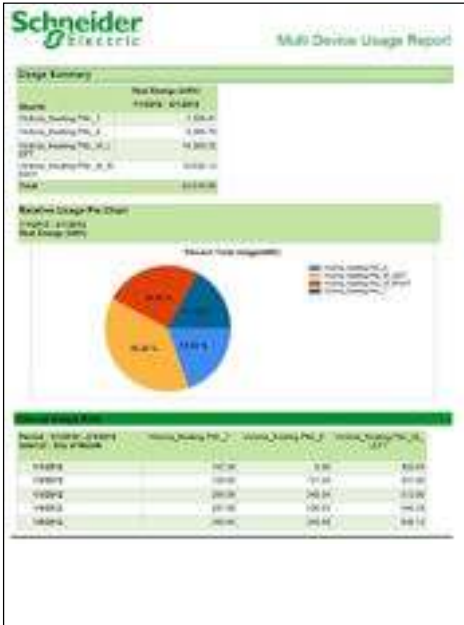

EcoStruxure provides many different report templates to allow users to easily display and deliver the information they need



## Scalable, flexible architecture

### Reporting

Reports – generate or edit historical reports for energy cost, consumption, and power quality (requires Microsoft SQL Server Standard Edition).

- Powerful, intuitive reporting options let users see critical information exactly how, where, and when they need it
- Reports can be generated manually and saved as Excel, HTML, and other formats, or scheduled to automatically distribute to a printer or via email

### Configuration tools

Our power-management software is supplied with a package of configuration tools designed to make setup uniquely easy and quick.

- Designed to help make project setup and network configuration fast and easy
- Provides standard device types and their associated profiles and allows engineers to easily customize the profiles of the devices specific to the project
- Standardized tags per device profile (configurable), XML file
- Standard interface for quick database generation
- Instantiation of devices, on a per object basis
- Creates tags, trends, alarms, and events when devices are added to system
- Batch editing supported by automation interface

### Manual and automated control

- Perform fast, manual control operations by clicking on-screen trigger buttons, and operate remote breakers, relays, and other power distribution and mitigation equipment
- Perform manual or setpoint-triggered functions
- Coordinate control of multiple loads, generators, relays, etc.
- Support energy-saving applications
- Manage distributed energy assets
- Automate substations and reduce service time

### Interoperability

- Integrate all energy-management and automation systems (SCADA, BAC, DCS, ERP, etc.)
- Share data with third-party, automation, and accounting systems
- Comply with ODBC, OPC, and PQDIF standards

### Patented ION technology

EcoStruxure power management software and a variety of PowerLogic ION metering products feature the unique ION architecture. This modular, flexible architecture offers extensive customization of functionality using a simple building block approach. The technology uniquely addresses advanced monitoring and control applications and adapts to changing needs, avoiding obsolescence.

### Global solutions

Software is available in many languages – English, French, Spanish, German, and Chinese. Software needs to be installed by Schneider Electric’s Power Solution Application team or by a certified partner of Schneider Electric. Contact your Schneider Electric representative.



To learn more, visit [www.schneider-electric.us/powerandenergy](http://www.schneider-electric.us/powerandenergy)

Schneider Electric  
6700 Tower Circle  
Franklin, TN 37067  
1-888-797-6468  
[www.schneider-electric.com/us](http://www.schneider-electric.com/us)

As standards, specifications, and designs develop from time to time, please ask for confirmation of the information given in this document.

© 2019 Schneider Electric. All Rights Reserved. Life Is On Schneider Electric is a trademark and the property of Schneider Electric SE, its subsidiaries and affiliated companies.  
998-20514554\_GMA-US