

# Measuring and monitoring relays

## Product group picture

2



# Measuring and monitoring relays

## Table of contents

<b>Measuring and monitoring relays</b>	
Measuring and monitoring relays	2/1
Product group picture	2/1
Table of contents	2/2
Benefits and advantages	2/3
Monitoring features and application ranges	2/5
Approvals and marks	2/7
Current and voltage monitoring relays, single-phase	2/9
Three-phase monitoring relays	2/27
Insulation monitoring relays for unearthed supply systems	2/53
Motor load monitoring relays	2/69
Motor control and protection	2/75
Thermistor motor protection relays	2/81
Temperature monitoring relays	2/91
Liquid level monitors and controls	2/103
Contact protection and Sensor interface relays	2/117
Cycle monitoring relay with watchdog function	2/123
General technical data, Accessories, Current transformers	2/127

# Measuring and monitoring relays

## Benefits and advantages

### Benefits CM-E range

2



- Only 22.5 mm wide housing
- Output contacts: 1 c/o contact or 1 n/o contact
- One supply voltage range
- One monitoring function
- Cost-efficient solution for OEM applications
- Preset monitoring ranges

### CM-S range: Universal and multifunctional



- Only 22.5 mm wide housing
- Output contacts: 1 or 2 c/o (SPDT) contacts
- One supply voltage range or supplied by measuring circuit
- Setting and operation via front-face operating controls
- Adjustment of threshold values and switching hysteresis via direct reading scale
- Integrated and snap-fitted front-face marker
- Snap-on housing: The relays can be placed on a DIN rail tool-free - just snap it on or remove it tool-free
- Sealable transparent cover (accessory)

### Combination screws ①

Easy tightening and release of the connection screws with pozidrive, pan- or crosshead screwdriver.

### Safety ②

The "real distance" is hidden. The clearance and the creepage distances of our products exceed international standards and substantially increase the safety of our products.



1SVR 110 000 F0606

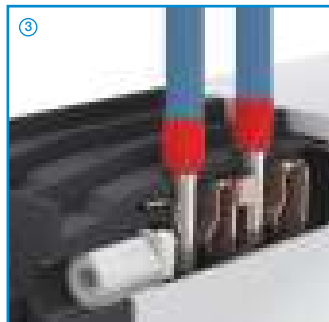

2CDC 253 026 F0011

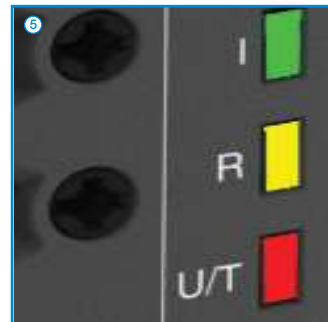

2CDC 253 035 F0011

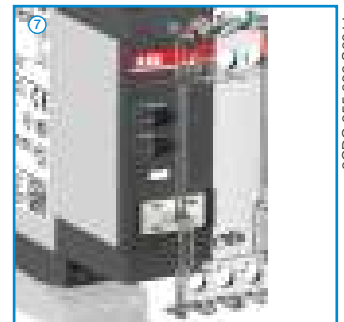

2CDC 255 006 S0011

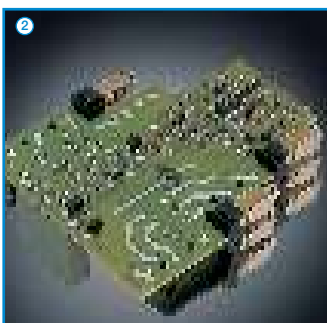

2CDC 253 011 F0003

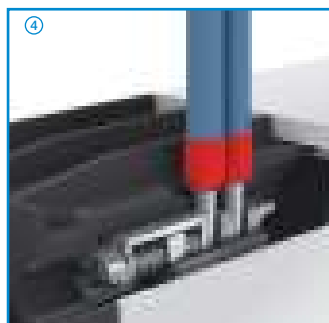

2CDC 253 025 F0011



2CDC 253 007 F0012

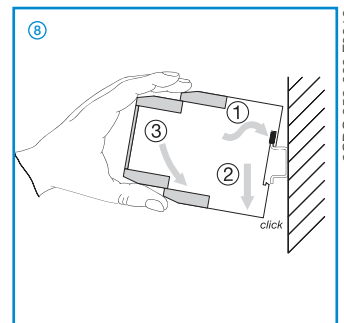

2CDC 253 006 F0010

# Measuring and monitoring relays

## Benefits and advantages

### CM-N range: Multifunctional



- 45 mm wide housing
- Output contacts: 2 c/o (SPDT) contacts
- Continuous voltage range (24-240 V AC/DC) or single-supply
- Setting and operation via front-face operating controls
- Adjustment of threshold values and switching hysteresis via direct reading scale
- Adjustable time delays
- Integrated and snap-fitted front-face marker label
- Sealable transparent cover (accessory)

### ABB's measuring and monitoring relays in a new housing

#### Benefits at a glance

#### Double-chamber cage connection terminals

##### Easy conversions:

The old range of measuring and monitoring relays is replaced by an identical range of relays with Double-chamber cage connection terminals.

The ordering number just changed in one digit:

1SVRx3 ... changed to 1SVR73...

1SVRx5 ... changed to 1SVR75...

and for the type designator we are using one more specifier:

CM-xxS changed to CM-xxS.S

CM-xxN changed to CM-xxN.S

The new range is identically replacing the old range.

#### Extended features

##### Flammability:

The plastic housing material used meets the requirements for the highest flammability class. (UL94 V-0 rated)

##### Look and feel:

The new housing fits perfectly with ABB's control products offer.

### Easy Connect Technology & Double-chamber cage connection terminals

#### Benefits new CM-S range housing

##### Easy Connect Technology ③

Tool-free wiring for excellent vibration resistance. Push-in terminals provide connection of wires up to 2 x 0.5 - 1.5 mm<sup>2</sup>, rigid or fine stranded with or without wire end ferrules.

##### Double-chamber cage connection terminals ④

Double-chamber cage connection terminals provide connection of wires up to 2 x 0.5-2.5 mm<sup>2</sup> (2 x 20-14 AWG) rigid or fine-strand, with or without wire end ferrules. Potential distribution does not require additional terminals.

##### LED's for status indication ⑤

All actual operational states are displayed by front-face LED's, thus simplifying commissioning and troubleshooting.

##### Integrated marker label ⑥

Integrated marker labels allow the product to be marked quickly and simply. No additional marker labels are required.

##### Sealable transparent cover ⑦

Protection against unauthorized changes of time and threshold values. Available as an accessory.

##### Snap-On housing ⑧

Tool-free DIN rail installation and deinstallation of the monitoring relay with Snap-On housing.

#### Easy Connect Technology

##### New options:

Additionally to the existing well established screw connections a new innovative connection technology can be offered: Easy Connect Technology with push-in terminals.

##### Tool-free wiring:

The push-in terminals can be wired with rigid or fine stranded wires with wire end ferrules totally tool-free. The connection direction is exactly the same as the screw version.

##### Higher utility class:

The Easy Connect Technology provides excellent vibration resistance with gas tight push-in terminals – the right solution for harsh environment.

# Measuring and monitoring relays

## Monitoring features and application ranges

2

### Single-phase current and voltage monitoring

- Over- or undercurrent monitoring CM-SRS and CM-SRS.M
- Over- and undercurrent monitoring CM-SFS
- Over- or undervoltage monitoring CM-ESS and CM-ESS.M
- Over- and undervoltage monitoring CM-EFS

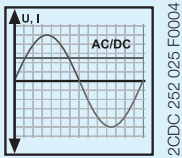

#### Current monitoring

- Monitoring of motor current consumption
- Monitoring of lighting installations and heating circuits
- Monitoring of hoisting gear and transportation equipment overload
- Monitoring of locking devices, electromechanical brake gear and locked rotor

#### Voltage monitoring

- Speed monitoring of DC motors
- Monitoring of battery voltages and other supply networks
- Monitoring of upper and lower voltage threshold values

### Insulation monitoring

- CM-IWS.2 for electrically isolated AC systems, and CM-IWS.1 & CM-IWN.1 for electrically isolated AC, DC and mixed AC/DC systems.
- CM-IWN.5 for solar applications  $\leq 1000 \mu\text{F}$

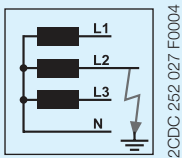

#### Insulation monitoring

- Monitoring of electrically isolated supply mains for insulation resistance failure
- Detection of initial faults
- Protection against earth faults

### Thermistor motor protection

CM-MSE, CM-MSS and CM-MSN provide full protection of motors with integrated PTC resistor sensors.

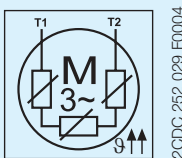

#### Thermistor motor protection

- Protection of motors against thermal overload, e. g. caused by insufficient cooling, heavy load starting conditions, undersized motors, etc.

### Three-phase monitoring

- Phase loss CM-PBE
- Over- and undervoltage CM-PVE
- Phase sequence and phase loss CM-PFE and CM-PFS
- Phase sequence and phase loss, over- and undervoltage CM-PSS.xx and CM-PVS.xx
- Phase sequence and phase loss, unbalance CM-PAS.xx
- Phase sequence and phase loss, unbalance, over- and undervoltage CM-MPS.xx and CM-MPN.xx
- Over- and undervoltage, over- and underfrequency CM-UFS.x

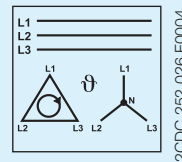

#### Three-phase voltage monitoring

- Voltage monitoring of mobile three-phase equipment
- Protection of personnel and installations against phase reversal
- Monitoring of the supply voltage to machines and installations
- Protection of equipment against damage caused by unstable supply voltage
- Switching to emergency or auxiliary supply
- Protection of motors against damage caused by unbalanced phase voltages and phase loss
- Automatic connection & disconnection of decentralised power stations to the grid

### Motor load monitoring

CM-LWN monitoring relays load states of single- and three-phase asynchronous motors.

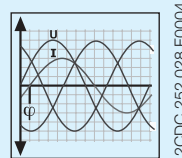

#### Motor load monitoring

- Detection of V-belt breaking
- Motor protection against overload
- Monitoring of filters for clogging
- Protection of pumps against dry running
- Detection of high pressure in conduit systems
- Monitoring for dulling blades in sawing and cutting machines

### Liquid level monitoring

CM-ENE, CM-ENS and CM-ENN for control and regulation of liquid levels and ratios of mixtures of conductive fluids.

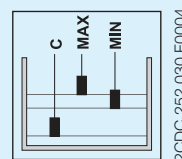

#### Liquid level monitoring and control

- Protection of pumps against dry running
- Protection against container overflow
- Control of liquid levels
- Detection of leaks
- Control of mixing ratios

# Measuring and monitoring relays

## Monitoring features and application ranges

### Contact protection, sensor evaluation

The CM-KRN protects sensitive control contacts from excessive loads and can store switch positions. The CM-SIS supplies and evaluates NPN and PNP sensors.

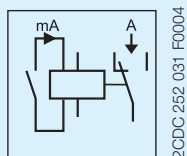

#### Contact protection / sensor evaluation

- Storage of the switching states of bouncing contacts
- Amplification of the switch state information of sensitive contacts
- Supply and evaluation of NPN or PNP sensors

### Cycle monitoring

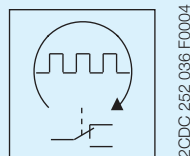

#### Cycle monitoring

- External monitoring of the correct function of programmable logic controllers (plc) and industrial pcs (ipc)

### Temperature monitoring

Acquisition, messaging and regulation of temperatures of solid, liquid and gaseous media in processes and machines via PT100, PT1000, KTY83, KTY 84 or NTC sensors with C510, C511, C512, C513.

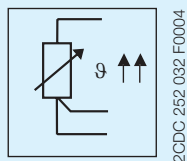

#### Temperature monitoring

- Motor and system protection
- Control panel temperature monitoring
- Frost monitoring
- Temperature limits for process variables, e.g. in the packing or electroplating industry
- Control of systems and machines like heating, air-conditioning and ventilation systems, solar collectors, heat pumps or hot water supply systems
- Monitoring of servomotors with KTY sensors
- Bearing and gear oil monitoring
- Coolant monitoring

# Measuring and monitoring relays

## Approvals and marks

2

		Current and voltage monitoring, single-phase							Three-phase monitoring													
		CM-SFS.1x	CM-SFS.2x	CM-SFS.M	CM-SFS.2	CM-ESS.2x	CM-ESS.M	CM-EFS.2	CM-PBE	CM-PVE	CM-PFE	CM-PFS	CM-PSS.x1	CM-PVS.x1	CM-PAS.x1	CM-MPS.x1	CM-MPS.x3	CM-MPN.52	CM-MPN.62	CM-MPN.72	CM-UFS.2	
<b>Approvals</b>																						
	UL 508, CAN/CSA C22.2 No.14	■	■	■	■	■	■	■	■	■	■	■	■	■	■	■	■	■	■	■	■	■
	GL	□	□	□	□	□	□	□														
	GOST	■	■	■	■	■	■	■	■	■	■	■	■	■	■	■	■	■	■	■	■	■
	CB scheme	■	■	■	■	■	■	■	■	■	■	■	■	■	■	■	■	■	■	■	■	■
	CCC	■	■	■	■	■	■	■	■	■	■	■	■	■	■	■	■	■	■	■	■	■
	RMRS	■	■	■	■	■	■	■	■	■	■	■										
	ENEL DK 5940 Ed. 2.2																					■
<b>Marks</b>																						
	CE	■	■	■	■	■	■	■	■	■	■	■	■	■	■	■	■	■	■	■	■	■
	C-Tick	■	■	■	■	■	■	■	■	■	■	■	■	■	■	■	■	■	■	■	■	■

		Insulation monitoring relays for un-grounded supply mains					Motor load monitoring			Temperature monitoring			Contact protection, sensor interface					
		CM-IWS.2	CM-IWS.1	CM-IWN.1	CM-IWN.5	CM-IWN	CM-LWN			CM-TCS	C512	C513	CM-KRN	CM-SIS				
<b>Approvals</b>																		
	UL 508, CAN/CSA C22.2 No.14	■	■	■	■	■	■			■	■	■	■	■				
	GL	■	■	■		■	■						■					
	GOST	■	■	■	■	■	■			■			■	■				
	CB scheme	■	■	■	□	■	■			■								
	CCC	■	■	■	□	■	■			■								
	RMRS						■						■	■				
<b>Marks</b>																		
	CE	■	■	■	■	■	■			■	■	■	■	■				
	C-Tick	■	■	■	■	■	■			■				■				

		Cycle monitoring			Thermistor motor protection									Liquid level monitoring					
		CM-WDS			CM-MSE	CM-MSS (1)	CM-MSS (2)	CM-MSS (3)	CM-MSS (4)	CM-MSS (5)	CM-MSS (6)	CM-MSS (7)	CM-MSN	CM-ENE MIN	CM-ENE MAX	CM-ENS	CM-ENS UP/...	CM-ENN	CM-ENN UP/...
<b>Approvals</b>																			
	UL 508, CAN/CSA C22.2 No.14	■			■	■	■	■	■	□	■	■	■	■	■	■	■	■	■
	GL					■	■	■	■	■	■	■				■		■	
	GOST	■			■	■	■	■	■	■	■	■		■	■	■	■	■	■
	II (2) G D, PTB 02 ATEX 3080																		
	CB scheme				■	■	■	■	■	■	■	■		■	■	■	■	■	■
	CCC				■	■	■	■	■	■	■	■		■	■	■	■	■	■
	RMRS	■			■	■	■	■	■	■	■	■		■	■	■	■	■	■
<b>Marks</b>																			
	CE	■			■	■	■	■	■	■	■	■		■	■	■	■	■	■
	C-Tick				■	■	■	■	■	■	■	■		■	■	■	■	■	■

<sup>1)</sup> Versions with safety isolation without approval

# Measuring and monitoring relays

## Notes

A series of horizontal dotted lines for taking notes.



# Current and voltage monitoring relays, single-phase

## Product group picture

2



# Current and voltage monitoring relays, single-phase

## Table of contents

<b>Current and voltage monitoring relays, single-phase</b>	
Product group picture	2/9
Table of contents	2/10
Benefits and advantages	2/11
Notes	2/12
Selection and conversion	2/13
Ordering details - Current monitors	2/15
Ordering details - Voltage monitors	2/16
Function diagrams	2/17
Connection diagrams, DIP switches	2/20
Technical data	2/22
Notes	2/26

# Current and voltage monitoring relays, single-phase

## Benefits and advantages

2



### Characteristics current monitoring relays

- Monitoring of DC and AC currents: 3 mA to 15 A <sup>1)</sup>
- TRMS measuring principle
- One device includes 3 measuring ranges
- Over- and undercurrent monitoring<sup>1)</sup>
- ON or OFF delay configurable<sup>1)</sup>
- Open- or closed circuit principle configurable<sup>1)</sup>
- Latching function configurable<sup>1)</sup>
- Thresholds for >I and/or <I adjustable<sup>1)</sup>
- Fixed hysteresis of 5 %<sup>1)</sup>
- Start-up delay  $T_v$  adjustable 0; 0.1 - 30 s<sup>1)</sup>
- Tripping delay  $T_v$  adjustable 0; 0.1 - 30 s<sup>1)</sup>
- 1 x 2 c/o contacts (common signal) or 2 x 1 c/o contact (separate signals for >I and <I) configurable<sup>1)</sup>
- 22.5 mm width
- 3 LED's for status indication

<sup>1)</sup> depending on device

### Current monitoring, single-phase

The ABB current monitoring relays CM-SRS.xx reliably monitor the occurrence of currents that exceed or fall below the selected threshold value. The functions overcurrent or undercurrent monitoring can be preselected. Single- and multifunction devices for the monitoring of direct or alternating currents from 3 mA to 15 A are available.

### Current window monitoring ( $I_{min}$ , $I_{max}$ )

The window monitoring relay CM-SFS.2x is available if the application requires the simultaneous monitoring of over- and undercurrents.

### Characteristics voltage monitoring relays

- Monitoring of DC and AC voltages from 3 - 600 V
- TRMS measuring principle
- One device includes 4 measuring ranges: 3 - 30 V; 6 - 60 V; 30 - 300 V; 60 - 600 V
- Over- and undervoltage monitoring<sup>1)</sup>
- ON or OFF delay configurable<sup>1)</sup>
- Open- or closed circuit principle configurable<sup>1)</sup>
- Latching function configurable<sup>1)</sup>
- Threshold values for >U and/or <U adjustable<sup>1)</sup>
- Fixed hysteresis of 5 %<sup>1)</sup>
- Start-up delay  $T_v$  adjustable 0; 0.1 - 30 s<sup>1)</sup>
- Tripping delay  $T_v$  adjustable 0; 0.1 - 30 s<sup>1)</sup>
- 1 x 2 c/o contacts (common signal) or 2 x 1 c/o contact (separate signals for >U and <U) configurable<sup>1)</sup>
- 22.5 mm width
- 3 LED's for status indication

### Voltage monitoring, single-phase

The ABB voltage monitoring relays CM-SRS.xx are used to monitor direct and alternating voltages within a range of 3-600 V. Over- or undervoltage detection can be preselected.

### Voltage window monitoring ( $U_{min}$ , $U_{max}$ )

For the simultaneous detection of over- and undervoltages, the window monitoring relay CM-EFS.2 can be used.

# Current and voltage monitoring relays, single-phase

## Notes

Lined area for notes, consisting of multiple horizontal dotted lines.



# Current and voltage monitoring relays, single-phase

## Selection and conversion

Type	Order number	Predecessor
CM-ESS.1S	1SVR 730 831 R0300	1SVR 430 831 R0300
CM-ESS.1P	1SVR 740 831 R0300	
CM-ESS.1S	1SVR 730 831 R0300	1SVR 430 831 R0300
CM-ESS.1P	1SVR 740 831 R0300	
CM-ESS.1S	1SVR 730 831 R1300	1SVR 430 831 R1300
CM-ESS.1P	1SVR 740 831 R1300	
CM-ESS.2S	1SVR 730 830 R0400	1SVR 430 830 R0400
CM-ESS.2P	1SVR 740 830 R0400	
CM-ESS.2S	1SVR 730 831 R0400	1SVR 430 831 R0400
CM-ESS.2P	1SVR 740 831 R0400	
CM-ESS.2S	1SVR 730 831 R1400	1SVR 430 831 R1400
CM-ESS.2P	1SVR 740 831 R1400	
CM-ESS.MS	1SVR 730 830 R0500	1SVR 430 830 R0500
CM-ESS.MP	1SVR 740 830 R0500	
CM-EFS.2S	1SVR 730 750 R0400	1SVR 430 750 R0400
CM-EFS.2P	1SVR 740 750 R0400	

Rated control supply voltage $U_c$	1	2	3	4	5	6	7	8	9	10	11	12	13	14
24 - 240 V AC/DC	■	■						■	■				■	■
110 - 130 V AC			■	■						■	■			
220 - 240 V AC					■	■					■	■		

Measuring ranges AC/DC	1	2	3	4	5	6	7	8	9	10	11	12	13	14
3 - 30 V	■	■	■	■	■	■	■	■	■	■	■	■	■	■
6 - 60 V	■	■	■	■	■	■	■	■	■	■	■	■	■	■
30 - 300 V	■	■	■	■	■	■	■	■	■	■	■	■	■	■
60 - 600 V	■	■	■	■	■	■	■	■	■	■	■	■	■	■

Monitoring function	1	2	3	4	5	6	7	8	9	10	11	12	13	14
Over- or undervoltage	■	■	■	■	■	■	■	■	■	■	■	■	■	■
Windows voltage monitoring													■	■
Latching													sel	sel
Open circuit or closed circuit principle													sel	sel

Timing functions for tripping delay	1	2	3	4	5	6	7	8	9	10	11	12	13	14
ON delay, 0 or 0,1 - 30 s							adj	adj	adj	adj	adj	adj	adj	adj
ON or OFF delay														sel

Output	1	2	3	4	5	6	7	8	9	10	11	12	13	14
c/o contact	1	1	1	1	1	1	2	2	2	2	2	2	2	2

  

Connection type	1	2	3	4	5	6	7	8	9	10	11	12	13	14
Push-in terminals		■		■		■		■		■		■		■
Double-chamber cage connection terminals	■		■		■		■		■		■		■	

# Current and voltage monitoring relays, single-phase

## Ordering details - Current monitors

2

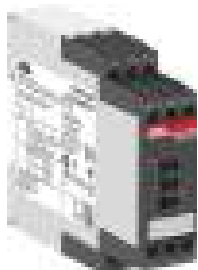

2CDC251 054 V0011

CM-SRS.22S



2CDC251 056 V0011

CM-SFS.22P

### Description

The CM range current monitoring relays protect single-phase mains (DC or AC) from over- and undercurrent from 3 mA to 15 A. Two different terminal versions are available. You can choose between the proven screw connection technology (double-chamber cage connecting terminals) and the completely tool-free Easy Connect Technology (push-in terminals).

### Ordering details

Rated control supply voltage	Tripping delay $T_v$	Measuring range	Type	Order code	Price 1 pce	Weight (1 pce) kg (lb)
24-240 V AC/DC	without	3-30 mA 10-100 mA 0.1-1 A	CM-SRS.11S	1SVR730840R0200		0.145 (0.320)
110-130 V AC				1SVR730841R0200		0.161 (0.355)
220-240 V AC				1SVR730841R1200		0.161 (0.355)
24-240 V AC/DC			CM-SRS.11P	1SVR740840R0200		0.137 (0.302)
110-130 V AC				1SVR740841R0200		0.153 (0.337)
220-240 V AC				1SVR740841R1200		0.153 (0.337)
24-240 V AC/DC	without	0.3-1.5 A 1-5 A 3-15 A	CM-SRS.12S	1SVR730840R0300		0.137 (0.302)
110-130 V AC				1SVR730841R0300		0.168 (0.370)
220-240 V AC				1SVR730841R1300		0.168 (0.370)
24-240 V AC/DC			CM-SRS.21S	1SVR730840R0400		0.152 (0.335)
110-130 V AC				1SVR730841R0400		0.179 (0.395)
220-240 V AC				1SVR730841R1400		0.179 (0.395)
24-240 V AC/DC	adjustable 0 or 0.1-30 s	3-30 mA 10-100 mA 0.1-1 A	CM-SRS.21P	1SVR740840R0400		0.141 (0.311)
110-130 V AC				1SVR740841R0400		0.168 (0.370)
220-240 V AC				1SVR740841R1400		0.168 (0.370)
24-240 V AC/DC	adjustable 0 or 0.1-30 s	0.3-1.5 A 1-5 A 3-15 A	CM-SRS.22S	1SVR730840R0500		0.144 (0.399)
110-130 V AC				1SVR730841R0500		0.181 (0.399)
220-240 V AC				1SVR730841R1500		0.181 (0.399)
24-240 V AC/DC	adjustable 0 or 0.1-30 s	3-30 mA 10-100 mA 0.1-1 A	CM-SRS.M1S	1SVR730840R0600		0.153 (0.337)
24-240 V AC/DC			CM-SRS.M1P	1SVR740840R0600		0.142 (0.313)
24-240 V AC/DC	adjustable 0 or 0.1-30 s	0.3-1.5 A 1-5 A 3-15 A	CM-SRS.M2S	1SVR730840R0700		0.155 (0.342)
24-240 V AC/DC				CM-SFS.21S	1SVR730760R0400	
24-240 V AC/DC	adjustable 0 or 0.1-30 s	3-30 mA 10-100 mA 0.1-1 A	CM-SFS.21P	1SVR740760R0400		0.139 (0.306)
24-240 V AC/DC			CM-SFS.22S	1SVR730760R0500		0.158 (0.348)

# Current and voltage monitoring relays, single-phase

## Ordering details - Voltage monitors

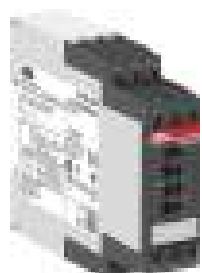

CM-ESS.MP

2CDC 251 080 V0011

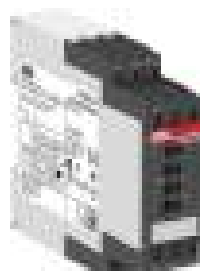

CM-EFS.2

2CDC 251 059 V0011

### Description

The CM range voltage monitoring relays provide reliable monitoring of voltages as well as detection of phase loss in single-phase mains.

All devices are available with two different terminal versions. You can choose between the proven screw connection technology (double-chamber cage connecting terminals) and the completely tool-free Easy Connect Technology (push-in terminals).

### Ordering details

Rated control supply voltage	Tripping delay $T_V$	Measuring range	Type	Order code	Price 1 pce	Weight (1 pce) kg (lb)
24-240 V AC/DC	without	3-30 V 6-60 V 30-300 V 60-600 V	CM-ESS.1S	1SVR730830R0300		0.135 (0.298)
110-130 V AC				1SVR730831R0300		0.164 (0.362)
220-240 V AC				1SVR730831R1300		0.164 (0.362)
24-240 V AC/DC			CM-ESS.1P	1SVR740830R0300		0.126 (0.278)
110-130 V AC				1SVR740831R0300		0.155 (0.342)
220-240 V AC				1SVR740831R1300		0.155 (0.342)
24-240 V AC/DC	adjustable 0 or 0.1-30 s	3-30 V 6-60 V 30-300 V 60-600 V	CM-ESS.2S	1SVR730830R0400		0.153 (0.337)
110-130 V AC				1SVR730831R0400		0.181 (0.399)
220-240 V AC				1SVR730831R1400		0.181 (0.399)
24-240 V AC/DC			CM-ESS.2P	1SVR740830R0400		0.142 (0.313)
110-130 V AC				1SVR740831R0400		0.170 (0.375)
220-240 V AC				1SVR740831R1400		0.170 (0.375)
24-240 V AC/DC	adjustable 0 or 0.1-30 s	3-30 V 6-60 V 30-300 V 60-600 V	CM-ESS.MS	1SVR730830R0500		0.154 (0.340)
			CM-ESS.MP	1SVR740830R0500		0.143 (0.320)
24-240 V AC/DC	adjustable 0 or 0.1-30 s	3-30 V 6-60 V 30-300 V 60-600 V	CM-EFS.2S	1SVR730750R0400		0.157 (0.346)
			CM-EFS.2P	1SVR740750R0400		0.146 (0.322)



# Current and voltage monitoring relays, single-phase

## Function diagrams

### Function diagrams CM-SRS.1

### Function diagrams CM-SRS.2

2

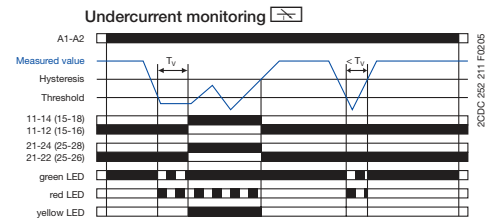
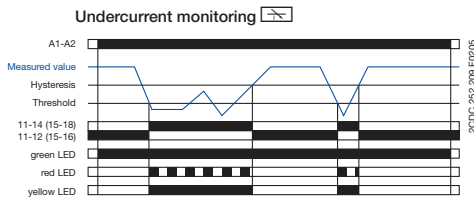
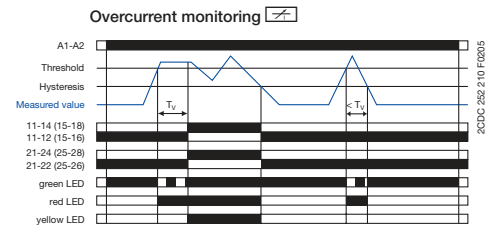
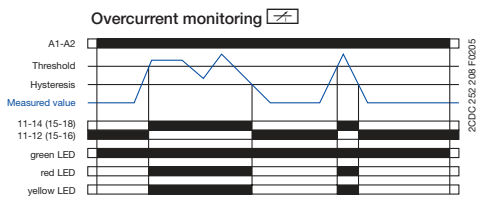

If the measured value exceeds resp. drops below the adjusted threshold value, the output relay(s) energize(s): on the CM-SRS.1 immediately, on the CM-SRS.2 after the set tripping delay  $T_V$ . If the measured value exceeds resp. drops below the threshold value plus resp. minus the adjusted hysteresis, the output relay(s) de-energize(s). The hysteresis is adjustable within a range of 3-30 % of the threshold value.

### Function diagrams CM-SRS.M

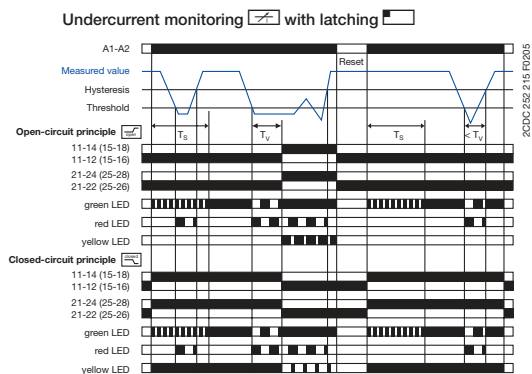
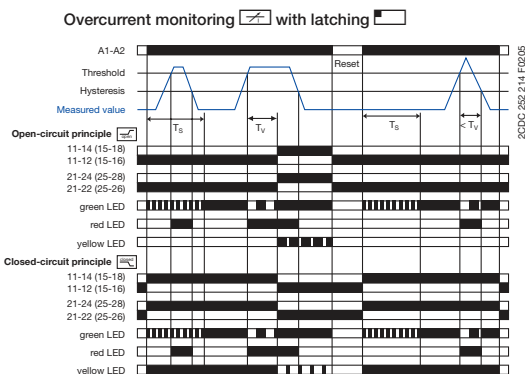
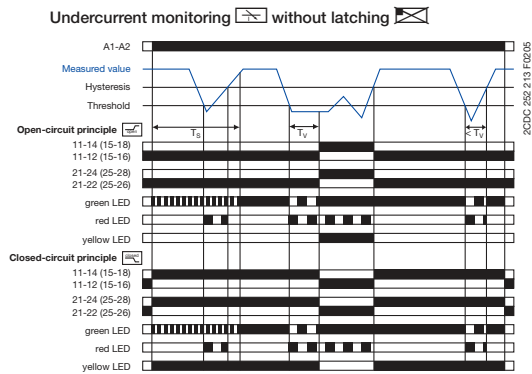
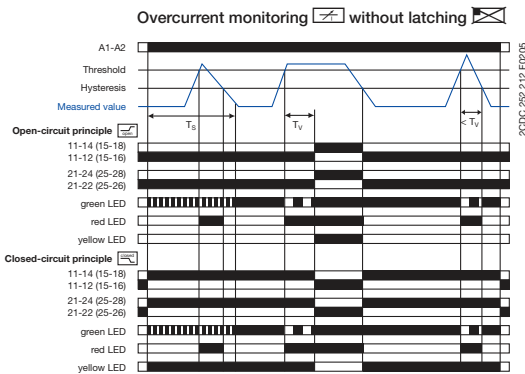

If the measured value exceeds resp. drops below the adjusted threshold value before the set start-up delay  $T_S$  is complete, the output relays do not change their actual state. If the measured value exceeds resp. drops below the adjusted threshold value when  $T_S$  is complete, the tripping delay  $T_V$  starts. If  $T_V$  is complete and the measured value is still exceeding resp. below the threshold value plus resp. minus the set hysteresis, the output relays energize / de-energize .

If the measured value exceeds resp. drops below the threshold value minus resp. plus the set hysteresis and the latching function is not activated , the output relays de-energize / energize . With activated latching function the output relays remain energized and de-energize only, when the supply voltage is interrupted / the output relays remain de-energized and energize only, when the supply voltage is switched off and then again switched on = Reset.

The hysteresis is adjustable within a range of 3-30 % of the threshold value.

# Current and voltage monitoring relays, single-phase



## Function diagrams

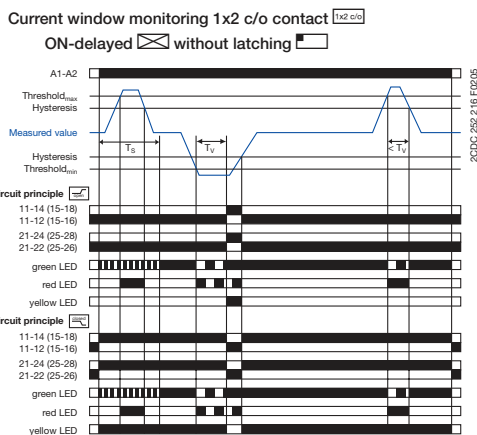



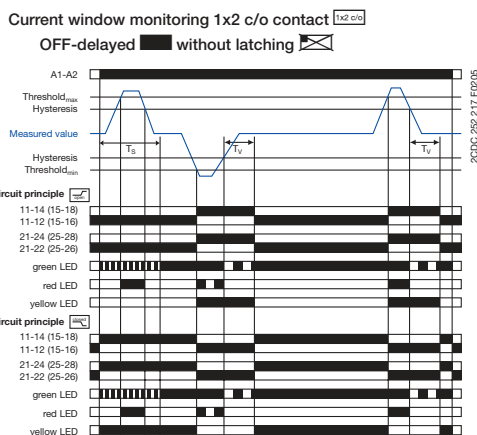



### Function diagrams CM-SFS.2









Further function diagrams see data sheet.









ON-delayed  current window monitoring with parallel switching c/o contacts   
 If the measured value exceeds resp. drops below the adjusted threshold value before the set start-up delay  $T_s$  is complete, the output relays do not change their actual state.

If the measured value exceeds resp. drops below the adjusted threshold value when  $T_s$  is complete, the tripping delay  $T_v$  starts, when  is configured. If  $T_v$  is complete and the measured value is still exceeding resp. below the threshold value minus resp. plus the fixed hysteresis (5%), the output relays energize  / de-energize . If the measured value exceeds resp. drops below the threshold value plus resp. minus the hysteresis and the latching function is not activated , the output relays de-energize  / energize . With activated latching function  the output relays remain energized  and de-energize only, when the supply voltage is interrupted / the output relays remain de-energized  and energize only, when the supply voltage is switched off and then again switched on = Reset.

OFF-delayed  current window monitoring with parallel switching c/o contacts   
 If the measured value exceeds resp. drops below the adjusted threshold value when the set start-up delay  $T_s$  is complete, the output relays energize  / de-energize  , when  is configured, and remain in this position during the set tripping delay  $T_v$ .

If the measured value exceeds resp. drops below the threshold value plus resp. minus the fixed hysteresis (5%) and the latching function is not activated , the tripping delay  $T_v$  starts.

After completion of  $T_v$ , the output relays de-energize  / energize , provided that the latching function is not activated . With activated latching function  the output relays remain energized  and de-energize only, when the supply voltage is interrupted / the output relays remain de-energized  and energize only, when the supply voltage is switched off and then again switched on = Reset.

When  is adjusted on the device, the functionality is equivalent to the one described above. There is only to consider that in this case, instead of both output relays, only one output relay each will be switched.

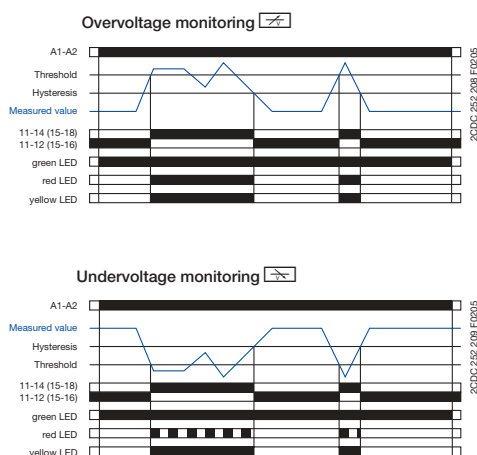

">" = 11<sub>15</sub>-12<sub>16</sub>/14<sub>18</sub> ; "<" = 21<sub>25</sub>-22<sub>26</sub>/24<sub>28</sub>

### Function diagrams CM-ESS.1

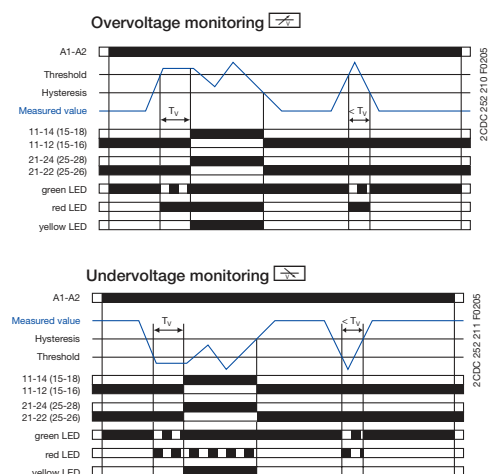

### Function diagrams CM-ESS.2



Depending on the configuration, the voltage monitoring relays **CM-ESS.1** and **CM-ESS.2** can be used for over-  or undervoltage monitoring  in single-phase AC and/or DC systems. The voltage to be monitored (measured value) is applied to terminals B-C. The devices work according to the open-circuit principle. If the measured value exceeds resp. drops below the adjusted threshold value, the output relay(s) energize(s): on the CM-ESS.1 immediately, on the CM-ESS.2 after the set tripping delay  $T_v$ . If the measured value exceeds resp. drops below the threshold value plus resp. minus the adjusted hysteresis, the output relay(s) de-energize(s). The hysteresis is adjustable within a range of 3-30 % of the threshold value.

# Current and voltage monitoring relays, single-phase

## Function diagrams

### Function diagrams CM-ESS.M

#### Overvoltage monitoring without latching

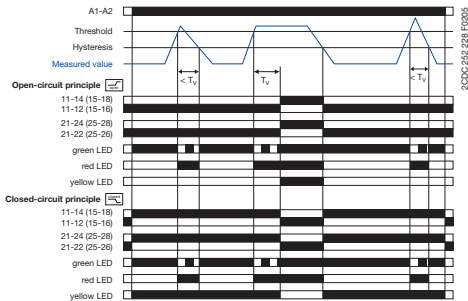

#### Overvoltage monitoring with latching

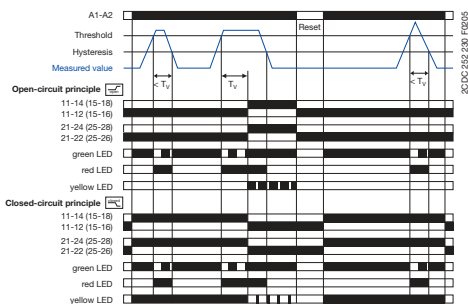

#### Undervoltage monitoring without latching

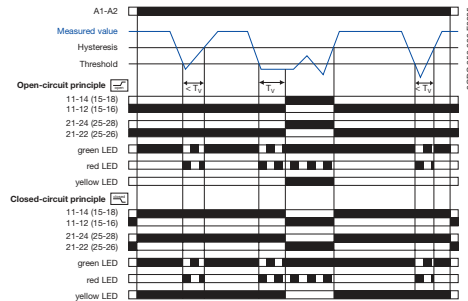

#### Undervoltage monitoring with latching

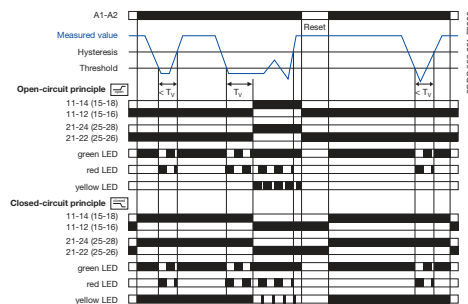

If the measured value exceeds resp. drops below the adjusted threshold value, the tripping delay  $T_V$  starts. If  $T_V$  is complete and the measured value is still exceeding resp. below the threshold value plus resp. minus the set hysteresis, the output relays energize / de-energize .

If the measured value exceeds resp. drops below the threshold value plus resp. minus the set hysteresis and the latching function is not activated , the output relays de-energize / energize . With activated latching function the output relays remain energized and de-energize only, when the supply voltage is interrupted / the output relays remain de-energized and energize only, when the supply voltage is switched off and then again switched on = Reset. The hysteresis is adjustable within a range of 3-30 % of the threshold value. Further function diagrams see data sheet.

#### Voltage window monitoring 1x2 c/o contact

##### ON-delayed without latching

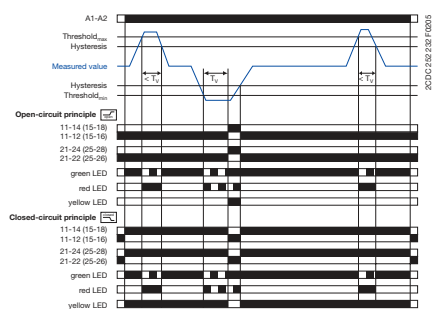

#### Voltage window monitoring 1x2 c/o contact

##### OFF-delayed without latching

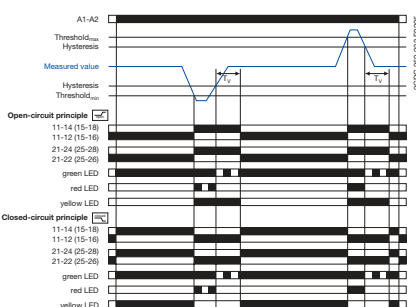

#### ON-delayed voltage window monitoring with parallel switching c/o contacts

If the measured value exceeds resp. drops below the adjusted threshold value, the tripping delay  $T_V$  starts, when is configured. If  $T_V$  is complete and the measured value is still exceeding resp. below the threshold value minus resp. plus the fixed hysteresis (5%), the output relays energize / de-energize .

If the measured value exceeds resp. drops below the threshold value plus resp. minus the hysteresis and the latching function is not activated , the output relays de-energize / energize . With activated latching function the output relays remain energized and de-energize only, when the supply voltage is interrupted / the output relays remain de-energized and energize only, when the supply voltage is switched off and then again switched on = Reset.

#### OFF-delayed voltage window monitoring with parallel switching c/o contacts

If the measured value exceeds resp. drops below the adjusted threshold value, the output relays energize / de-energize , when is configured, and remain in this position during the set tripping delay  $T_V$ .

If the measured value exceeds resp. drops below the threshold value plus resp. minus the fixed hysteresis (5%) and the latching function is not activated , the tripping delay  $T_V$  starts.

After completion of  $T_V$ , the output relays de-energize / energize , provided that the latching function is not activated . With activated latching function the output relays remain energized and de-energize only, when the supply voltage is interrupted / the output relays remain de-energized and energize only, when the supply voltage is switched off and then again switched on = Reset.

When is adjusted on the device, the functionality is equivalent to the one described above. There is only to consider that in this case, instead of both output relays, only one output relay each will be switched.

$$">U" = 11_{15-12,16}/14_{18}; "<U" = 21_{25-22,26}/24_{28}$$

# Current and voltage monitoring relays, single-phase

## Connection diagrams, DIP switches

### Connection diagram CM-SRS.1, CM-SRS.2

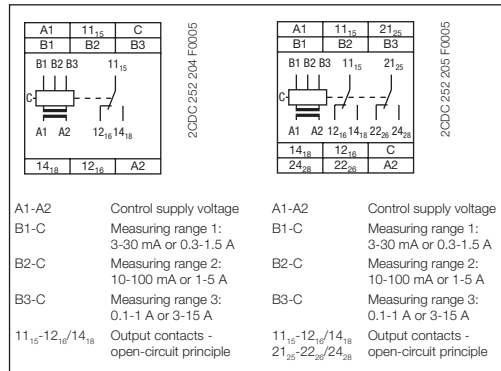

### DIP switch functions CM-SRS.1, CM-SRS.2

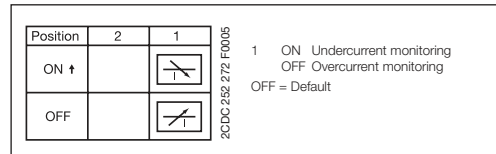

### Connection diagram CM-SRS.M

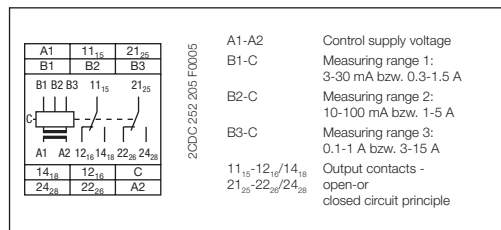

### DIP switch functions CM-SRS.M

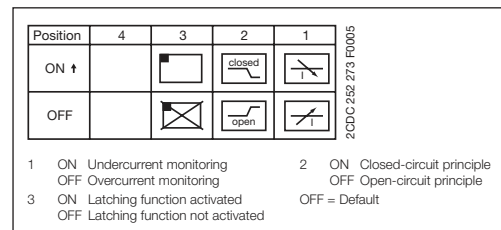

### Connection diagram CM-SFS.2

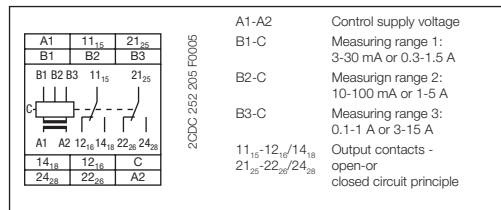

### DIP switch function CM-SFS.2

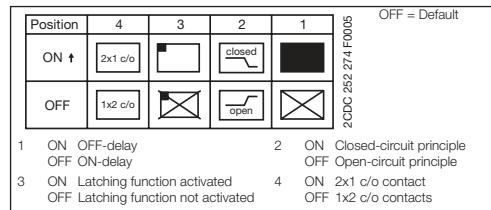

### Connection diagram CM-ESS.M

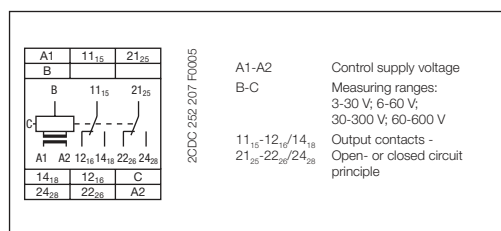

### DIP switch functions CM-ESS.M

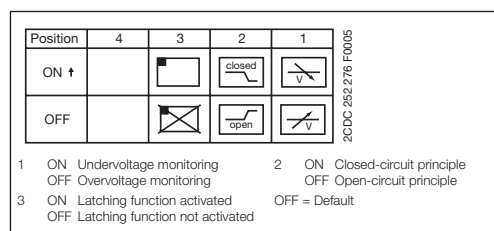

# Current and voltage monitoring relays, single-phase

## Connection diagrams, DIP switches

2

### Connection diagram CM-ESS.1, CM-ESS.2

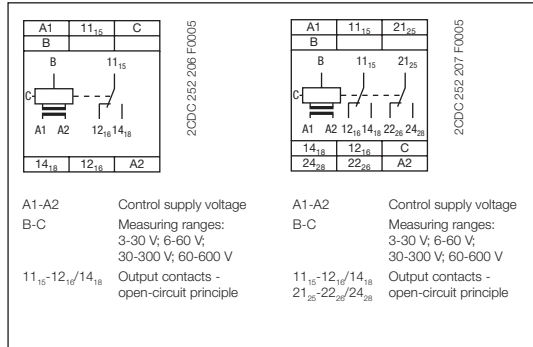

### DIP switch functions CM-ESS.1, CM-ESS.2

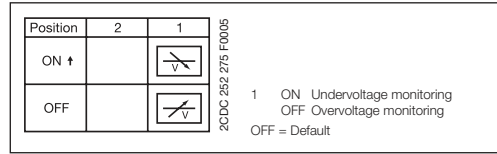

### Connection diagram CM-EFS.2

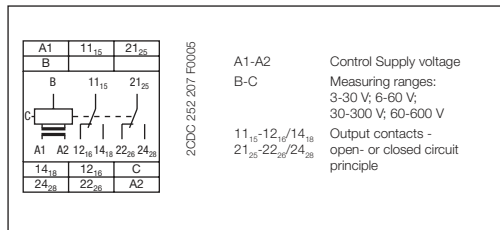

### DIP switch functions CM-EFS.2

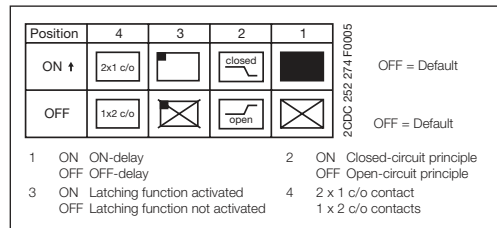

# Current monitoring relays, single-phase

## Technical data

Type		CM-SRS.1	CM-SRS.2	CM-SRS.M	CM-SFS.2
<b>Input circuit - Supply circuit</b>		<b>A1-A2</b>			
Rated control supply voltage $U_s$	A1-A2	110-130 V AC			
	A1-A2	220-240 V AC			
	A1-A2	24-240 V AC/DC			
Rated control supply voltage $U_s$ tolerance		-15...+10 %			
Rated frequency	AC versions	50/60 Hz			
	AC/DC versions	50/60 Hz or DC			
Current / power consumption		see data sheets			
Power failure buffering time		20 ms			
Transient overvoltage protection		Varistors			
<b>Input circuit - Measuring circuit</b>		<b>B1/B2/B3-C</b>			
Monitoring function		over- or undercurrent monitoring configurable			over- and under-current monitoring
Measuring method		True RMS measuring principle			
Measuring inputs		<b>CM-SxS.x1</b>		<b>CM-SxS.x2</b>	
	Terminal connection	<b>B1-C</b>	<b>B2-C</b>	<b>B3-C</b>	<b>B1-C</b>
	Measuring ranges AC/DC	3-30 mA	10-100 mA	0.1-1 A	0.3-1.5 A
	Input resistance	3.3 q	1 q	0.1 q	0.05 q
	Pulse overload capacity $t < 1$ s	500 mA	1 A	10 A	15 A
	Continuous capacity	50 mA	150 mA	1.5 A	2 A
Threshold value(s)		adjustable within the indicated measuring range			
Setting accuracy of threshold value		10 %			
Repeat accuracy (constant parameters)		0.07 % of full scale			
Hysteresis related to the threshold value		3-30 % adjustable			5 % fixed
Measuring signal frequency range		DC / 15 Hz - 2 kHz			
Rated measuring signal frequency range		DC / 50-60 Hz			
Maximum response time		AC: 80 ms / DC: 120 ms			
Accuracy within the control supply voltage tolerance		$\Delta U \leq 0.5$ %			
Accuracy within the temperature range		$\Delta U \leq 0.06$ % / °C			
<b>Timing circuit</b>					
Start-up delay $T_s$		none		0 or 0.1-30 s adjustable	
Tripping delay $T_V$		none	0 or 0.1-30 s adjustable		
Repeat accuracy (constant parameters)		$\pm 0.07$ % of full scale			
Accuracy within the control supply voltage tolerance		-	$\Delta t \leq 0.5$ %		
Accuracy within the temperature range		-	$\Delta t \leq 0.06$ % / °C		
<b>Indication of operational states</b>					
Control supply voltage	U/T: green LED	: control supply voltage applied, : start-up delay $T_s$ active, : tripping delay $T_V$ active			
Measured value	I: red LED	: overcurrent, : undercurrent			
Relay status	R: yellow LED	: relay energized, no latching function : relay energized, active latching function : relay de-energized, active latching function			
<b>Output circuits</b>		<b>11(15)-12(16)/14(18), 21(25)-22(26)/24(28) - Relays</b>			
Kind of output		1 c/o contact	2 c/o contacts	1x2 c/o contacts or 2x1 c/o contact configurable	
Operating principle <sup>1)</sup>		open-circuit principle		open- or closed-circuit principle configurable	
Contact material		AgNi			
Rated operational voltage $U$	IEC/EN 60947-1	250 V			
Minimum switching voltage / minimum switching current		24 V / 10 mA			
Maximum switching voltage / maximum switching current		250 V AC / 4 A AC			
Rated operational current $I_o$ (IEC/EN 60947-5-1)	AC12 (resistive) at 230 V	4 A			
	AC15 (inductive) at 230 V	3 A			
	DC12 (resistive) at 24 V	4 A			
	DC13 (inductive) at 24 V	2 A			
AC rating (UL 508)	Utilization category (Control Circuit Rating Code) max. rated operational voltage	B 300			
	max. continuous thermal current at B 300	300 V AC			
	max. making/breaking apparent power (Make/Break) at B 300	5 A			
Mechanical lifetime		30x10 <sup>6</sup> switching cycles			
Electrical lifetime (AC12, 230 V, 4 A)		0.1x10 <sup>6</sup> switching cycles			
Max. fuse rating to achieve short-circuit protection	n/c contact	6 A fast-acting	10 A fast-acting	6 A fast-acting	
	n/o contact	10 A fast-acting			

<sup>1)</sup> Open-circuit principle: output relay energizes if the measured value exceeds / falls below the adjusted threshold value  
 Closed-circuit principle: output relay de-energizes if measured value exceeds / falls below the adjusted threshold value

<sup>2)</sup> In case of measured currents > 10 A, lateral spacing has to be min. 10 mm

# Current monitoring relays, single-phase







## Technical data





2

Type		CM-SRS.1	CM-SRS.2	CM-SRS.M	CM-SFS.2
<b>General data</b>					
MTBF		on request			
Duty time		100%			
Dimensions (W x H x D)	product dimensions	22.5 x 85.6 x 103.7 mm (0.89 x 3.37 x 4.08 in)			
	packaging dimensions	97 x 109 x 30 mm (3.82 x 4.29 x 1.18 in)			
Weight	net weight	depending on device, see ordering details			
	gross weight	depending on device, see ordering details			
Mounting		DIN rail (IEC/EN 60715), snap-on mounting without any tool			
Mounting position		any			
Minimum distance to other units		10mm (0.39in) at measured current > 10 A <sup>2)</sup>			
Material of housing		UL 94 V-0			
Degree of protection	housing / terminals	IP50 / IP20			
<b>Electrical connection</b>					
Wire size		<b>Screw connection technology</b>		<b>Easy Connect Technology (Push-in)</b>	
	fine-strand with(out) wire end ferrule	1 x 0.5-2.5 mm <sup>2</sup> (1 x 20-14 AWG) 2 x 0.5-1.5 mm <sup>2</sup> (2 x 20-16 AWG)		2 x 0.5-1.5 mm <sup>2</sup> (2 x 20-16 AWG)	
		rigid	1 x 0.5-4 mm <sup>2</sup> (1 x 20-12 AWG) 2 x 0.5-2.5 mm <sup>2</sup> (2 x 20-14 AWG)		2 x 0.5-1.5 mm <sup>2</sup> (2 x 20-16 AWG)
Stripping length		8 mm (0.32 in)			
Tightening torque		0.6-0.8 Nm (5.31-7.08 lb.in)		-	
<b>Environmental data</b>					
Ambient temperature range	operation / storage	-20...+60 °C / -40...+85 °C			
Damp heat (IEC 60068-2-30)		55 °C, 6 cycles			
Vibration (sinusoidal) (IEC/EN 60255-21-1)		Class 2			
Shock (IEC/EN 60255-21-2)		Class 2			
<b>Isolation data</b>					
Rated insulation voltage (VDE 0110, IEC 60947-1, IEC/EN 60255-5)	supply / measuring circuit / output	600 V			
	supply / output 1/2	250 V			
Rated impulse withstand voltage U <sub>imp</sub> (IEC/EN 60947-1, IEC/EN 60255-5)	supply / measuring circuit / output	6 kV 1.2/50 μs			
	supply / output 1/2	4 kV 1.2/50 μs			
Pollution degree (VDE 0110, IEC 664, IEC/EN 60255-5)		3			
Overvoltage category (VDE 0110, IEC 664, IEC/EN 60255-5)		III			
<b>Standards</b>					
Product standard		IEC/EN 60255-6			
Low Voltage Directive		2006/95/EC			
EMC Directive		2004/108/EC			
<b>Electromagnetic compatibility</b>					
Interference immunity to		IEC/EN 61000-6-2			
electrostatic discharge	IEC/EN 61000-4-2	Level 3			
radiated, radio-frequency, electromagnetic field	IEC/EN 61000-4-3	Level 3			
electrical fast transient / burst	IEC/EN 61000-4-4	Level 3			
surge	IEC/EN 61000-4-5	Level 3			
conducted disturbances, induced by radio-frequency fields	IEC/EN 61000-4-6	Level 3			
Interference emission		IEC/EN 61000-6-3			
high-frequency radiated	IEC/CISPR 22; EN 55022	Class B			
high-frequency conducted	IEC/CISPR 22; EN 55022	Class B			

# Voltage monitoring relays, single-phase

## Technical data

Type	CM-ESS.1	CM-ESS.2	CM-ESS.M	CM-EFS.2
<b>Input circuit - Supply circuit</b>	<b>A1-A2</b>			
Rated control supply voltage $U_s$	A1-A2	110-130 V AC		
	A1-A2	220-240 V AC		
	A1-A2	24-240 V AC/DC		
Rated control supply voltage $U_s$ tolerance		-15...+10 %		
Rated frequency	AC versions	50/60 Hz		
	AC/DC versions	50/60 Hz or DC		
Current / power consumption	see data sheet			
Power failure buffering time	20 ms			
Transient overvoltage protection	Varistors			
<b>Input circuit - Measuring circuit</b>	<b>B-C</b>			
Monitoring function	over- or undervoltage monitoring configurable			over- and undervoltage monitoring configurable
Measuring method	True RMS measuring principle			
Measuring inputs	<b>CM-ExS</b>			
	Terminal connection	<b>B-C</b>	<b>B-C</b>	<b>B-C</b>
	Measuring range AC/DC	3-30 V	6-60 V	30-300 V
	Input resistance	600 k $\Omega$	600 k $\Omega$	600 k $\Omega$
	Pulse overload capacity $t < 1$ s	800 V	800 V	800 V
	Continuous capacity	660 V	660 V	660 V
Threshold value(s)	adjustable within the indicated measuring range			
Setting accuracy of threshold value	10 %			
Repeat accuracy (constant parameters)	$\pm 0.07$ % of full scale			
Hysteresis related to the threshold value	3-30 % adjustable			5 % fixed
Measuring signal frequency range	DC / 15 Hz - 2 kHz			
Rated measuring signal frequency range	DC / 50-60 Hz			
Maximum response time	AC: 80 ms / DC: 120 ms			
Accuracy within the control supply voltage tolerance	$\Delta U \leq 0.5$ %			
Accuracy within the temperature range	$\Delta U \leq 0.06$ % / $^{\circ}\text{C}$			
Transient overvoltage protection	Varistors			
<b>Timing circuit</b>				
Delay time $T_d$	none	0 or 0.1-30 s adjustable		
Repeat accuracy (constant parameters)	$\pm 0.07$ % of full scale			
Accuracy within the control supply voltage tolerance	-	$\Delta t \leq 0.5$ %		
Accuracy within the temperature range	-	$\Delta t \leq 0.06$ % / $^{\circ}\text{C}$		
<b>Indication of operational states</b>				
Control supply voltage	U/T: green LED	 : control supply voltage applied  : tripping delay $T_d$ active		
Measured value	U: red LED	 : overvoltage,  : undervoltage		
Relay status	R: yellow LED	 : relay energized, no latching function  : relay energized, active latching function  : relay de-energized, active latching function		
<b>Output circuits</b>				
Kind of output	1 c/o contact	2 c/o contacts	1x2 c/o contacts or 2x1 c/o contact configurable	
Operating principle <sup>1)</sup>	open-circuit principle		open- or closed-circuit principle configurable	
Contact material	AgNi			
Rated operational voltage $U_b$	IEC/EN 60947-1	250 V		
Minimum switching voltage / minimum switching current	24 V / 10 mA			
Maximum switching voltage / maximum switching current	250 V AC / 4 A AC			
Rated operational current $I_b$ (IEC/EN 60947-5-1)	AC12 (resistive) at 230 V	4 A		
	AC15 (inductive) at 230 V	3 A		
	DC12 (resistive) at 24 V	4 A		
	DC13 (inductive) at 24 V	2 A		

<sup>1)</sup> Open-circuit principle: output relay energizes if the measured value exceeds  / falls below  the adjusted threshold value  
 Closed-circuit principle: output relay de-energizes if measured value exceeds  / falls below  the adjusted threshold value<sup>2)</sup>



# Voltage monitoring relays, single-phase

## Technical data

2

Type		CM-ESS.1	CM-ESS.2	CM-ESS.M	CM-EFS.2
AC rating (UL 508)	Utilization category (Control Circuit Rating Code)	B 300			
	max. rated operational voltage	300 V AC			
	max. continuous thermal current at B 300	5 A			
	max. making/breaking apparent power (Make/Break) at B 300	3600/360 VA			
Mechanical lifetime		30x10 <sup>6</sup> switching cycles			
Electrical lifetime (AC12, 230 V, 4 A)		0.1x10 <sup>6</sup> switching cycles			
Max. fuse rating to achieve short-circuit protection	n/c contact	6 A fast-acting	10 A fast-acting		6 A fast-acting
	n/o contact	10 A fast-acting			
<b>General data</b>					
MTBF		on request			
Duty time		100%			
Dimensions (W x H x D)	product dimensions	22.5 x 85.6 x 103.7 mm (0.89 x 3.37 x 4.08 in)			
	packaging dimensions	97 x 109 x 30 mm (3.82 x 4.29 x 1.18 in)			
Weight	net weight	depending on device, see ordering details			
	gross weight	depending on device, see ordering details			
Mounting		DIN rail (IEC/EN 60715), snap-on mounting without any tool			
Mounting position		any			
Minimum distance to other units	vertical / horizontal	not necessary / not necessary			
Material of housing		UL 94 V-0			
Degree of protection	housing / terminals	IP50 / IP20			
<b>Electrical connection</b>					
Wire size		<b>Screw connection technology</b>		<b>Easy Connect Technology (Push-in)</b>	
	fine-strand with(out) wire end ferrule	1 x 0.5-2.5 mm <sup>2</sup> (1 x 20-14 AWG)		2 x 0.5-1.5 mm <sup>2</sup> (2 x 20-16 AWG)	
		2 x 0.5-1.5 mm <sup>2</sup> (2 x 20-16 AWG)			
rigid	1 x 0.5-4 mm <sup>2</sup> (1 x 20-12 AWG)		2 x 0.5-1.5 mm <sup>2</sup> (2 x 20-16 AWG)		
Stripping length		8 mm (0.32 in)			
Tightening torque		0.6-0.8 Nm (5.31-7.08 lb.in)		-	
<b>Isolation data</b>					
Rated insulation voltage (VDE 0110, IEC 60947-1, IEC/EN 60255-5)	supply / measuring circuit / output	600 V			
	supply / output 1/2	250 V			
Rated impulse withstand voltage U <sub>imp</sub> (IEC/EN 60947-1, IEC/EN 60255-5)	supply / measuring circuit / output	6 kV 1.2/50 μs			
	supply / output 1/2	4 kV 1.2/50 μs			
Pollution degree (VDE 0110, IEC 664, IEC/EN 60255-5)		3			
Overvoltage category (VDE 0110, IEC 664, IEC/EN 60255-5)		III			
<b>Standards</b>					
Product standard		IEC/EN 60255-6			
Low Voltage Directive		2006/95/EC			
EMC Directive		2004/108/EC			
<b>Electromagnetic compatibility</b>					
Interference immunity to electrostatic discharge	IEC/EN 61000-4-2	IEC/EN 61000-6-2 Level 3			
	IEC/EN 61000-4-3	Level 3			
radiated, radio-frequency, electromagnetic field	IEC/EN 61000-4-4	Level 3			
	IEC/EN 61000-4-5	Level 3			
electrical fast transient / burst surge	IEC/EN 61000-4-6	Level 3			
		Level 3			
conducted disturbances, induced by radio-frequency fields		Level 3			
		Level 3			
Interference emission		IEC/EN 61000-6-3			
high-frequency radiated	IEC/CISPR 22; EN 55022	Class B			
high-frequency conducted	IEC/CISPR 22; EN 55022	Class B			

# Current and voltage monitoring relays, single-phase

## Notes

A large area of horizontal dotted lines for writing notes.

# Three-phase monitoring relays

## Product group picture

2



# Three-phase monitoring relays

## Table of contents

---









<b>Three phase monitoring relays</b>	
Product group picture	2/27
Table of contents	2/28
Benefits and advantages, Applications	2/29
Notes	2/30
Selection and conversion	2/31
Ordering details	2/33
Function diagrams	2/35
Connection diagrams, DIP switches	2/40
Connection diagrams, DIP switches, Rotary switches	2/41
Notes	2/42

# Three-phase monitoring relays

## Benefits and advantages, Applications

2

### Characteristics of the CM range three-phase monitors

- Adjustable phase unbalance threshold value <sup>1)</sup>
- Adjustable ON-delay/OFF-delay time <sup>1)</sup>
- Dual frequency measuring 50/60 Hz
- Powered by the measuring circuit
- 1 n/o contact, 1 or 2 contacts
- LED status indication
- Approvals:      
- Marks:  
- Multifunctional and single-functional devices
- Phase loss monitoring
- Phase sequence monitoring <sup>1)</sup>
- Over- and undervoltage monitoring (fixed or adjustable)<sup>1)</sup>
- Wide-range operating voltage guarantees world-wide operation

<sup>1)</sup> depending on device type

### Phase unbalance monitoring

If the supply by the three-phase system is unbalanced due to uneven distribution of the load, the motor will convert a part of the energy into reactive power. This energy gets lost unexploited; also the motor is exposed to higher thermal stress. Other thermal protection devices fail to detect continuing unbalances which can lead to damage or destruction of the motor. The CM range three-phase monitors with phase unbalance monitoring can reliably detect this critical situation.

### Phase sequence

Changing the phase sequence during operation or a wrong phase sequence prior to startup causes a change of the rotational direction of the connected device. Generators, pumps or fans rotate in the wrong direction and the installation is no longer working properly. Especially for moveable equipment, such as construction machinery, phase sequence detection prior to the startup process is highly reasonable.

### Phase loss

In case of phase loss, undefined states of the installation are likely to occur. E.g. the startup process of motors is disturbed. All three-phase monitors of the ABB CM range detect a phase loss as soon as the voltage of one phase drops below 60% of its nominal value.

### Voltage monitoring

All electric devices can be damaged when operated continuously in a network with out-of-range voltages. For example, safe starting is not ensured in case of undervoltage. Also, the switching state of a contactor is not clearly defined when operated in a „forbidden“ voltage range. This can lead to undefined states of the installation and cause damage or destruction of valuable parts.

### Extended functionality

ABB's new generation of three-phase monitoring relays feature additional functions making the application field for the devices considerably larger.

### Selectable phase sequence monitoring

The phase sequence monitoring can be switched off by means of a rotary switch or a DIP switch. This enables monitoring of three-phase mains where phase sequence is not relevant for the application, for example in case of motors with forward and reverse rotation, heating applications, etc.

### Automatic phase sequence correction

The automatic phase sequence correction is activated by means of a DIP switch. With activated phase sequence correction, it is ensured that for any non-fixed or portable equipment, e.g. construction machinery, the correct phase sequence is always applied to the input terminals of the load. For details regarding the wiring, please see function description / diagrams.

### Structure of the type designation

CM-\_\_ x.yz

x: width of enclosure

y: Control supply voltage / measuring range

1	110, 115, 120, 127 V supply systems (phase-neutral)
2	220, 230, 240 V supply systems (phase-neutral)
3	200, 208, 220, 230, 240, 257, 260 V supply systems (phase-phase)
4	440, 460 V supply systems (phase-phase)
5	480, 500 V supply systems (phase-phase)
6	575, 600 V supply systems (phase-phase)
7	660, 690 V supply systems (phase-phase)
8	200, 400 V supply systems (phase-phase)

z: Rated frequency / output circuit

1	50/60 Hz – 1x2 c/o
2	50/60 Hz – 1x2 or 2x1 c/o
3	50/60/400 Hz – 1x2 oder 2x1 c/o



- 1 Threshold value  $V_{min}/V_{max}$
- 2 R/T: yellow LED  
Relay status, timing  
  
F1: red LED  
fault message  
  
F2: red LED failure:  
- overvoltage: F1  
- undervoltage: F2  
- phase unbalance:  
F1 and F2 constant  
- phase loss: F1 on F2  
flashing  
- phase sequence:  
F1 and F2 alternately flashing
- 3 Adjustment of the tripping delay  
time setting 0.1-10 s
- 4 Adjustment of the threshold  
value for phase unbalance



# Three-phase monitoring relays

## Selection and conversion

Rated control supply voltage $U_c$	Predecessor																																					
	Type	Order number																																				
	CM-PBE	1SVR 550 881 R9400																																				
	CM-PBE	1SVR 550 882 R9500																																				
	CM-PVE	1SVR 550 870 R9400	no predecessor																																			
	CM-PVE	1SVR 550 871 R9500																																				
	CM-PFE	1SVR 550 824 R9100																																				
	CM-PFS.S <sup>1)</sup>	1SVR 730 824 R9300	1SVR 630 824 R9300																																			
	CM-PFS.P <sup>1)</sup>	1SVR 740 824 R9300																																				
	CM-PSS.31S	1SVR 730 784 R2300	1SVR 630 784 R2300																																			
	CM-PSS.31P	1SVR 740 784 R2300																																				
	CM-PSS.41S	1SVR 730 784 R3300	1SVR 630 784 R3300																																			
	CM-PSS.41P	1SVR 740 784 R3300																																				
	CM-PVS.31S	1SVR 730 794 R1300	1SVR 630 794 R1300																																			
	CM-PVS.31P	1SVR 740 794 R1300																																				
	CM-PVS.41S	1SVR 730 794 R3300	1SVR 630 794 R3300																																			
	CM-PVS.41P	1SVR 740 794 R3300																																				
	CM-PVS.81S	1SVR 730 794 R2300	1SVR 630 794 R2300																																			
	CM-PVS.81P	1SVR 740 794 R2300																																				
	CM-PAS.31S	1SVR 730 774 R1300	1SVR 630 774 R1300																																			
	CM-PAS.31P	1SVR 740 774 R1300																																				
	CM-PAS.41S	1SVR 730 774 R3300	1SVR 630 774 R3300																																			
	CM-PAS.41P	1SVR 740 774 R3300																																				
	CM-MPS.11S	1SVR 730 885 R1300	1SVR 630 885 R1300																																			
	CM-MPS.11P	1SVR 740 885 R1300																																				
	CM-MPS.21S	1SVR 730 885 R3300	1SVR 630 885 R3300																																			
	CM-MPS.21P	1SVR 740 885 R3300																																				
	CM-MPS.31S	1SVR 730 884 R1300	1SVR 630 884 R1300																																			
	CM-MPS.31P	1SVR 740 884 R1300																																				
	CM-MPS.41S	1SVR 730 884 R3300	1SVR 630 884 R4300																																			
<b>Phase to Phase</b>																																						
160-300 V AC																																						
200-400 V AC																																						
200-500 V AC																																						
208-440 V AC																																						
300-500 V AC																																						
320-460 V AC																																						
350-580 V AC																																						
380 V AC																																						
380-440 V AC																																						
400 V AC																																						
450-720 V AC																																						
530-820 V AC																																						
<b>Phase to Neutral</b>																																						
90-170 V AC																																						
180-280 V AC																																						
185-265 V AC																																						
220-240 V AC																																						
230 V AC																																						
<b>Rated frequency</b>																																						
50/60 Hz																																						
50/60/400 Hz																																						
<b>Suitable for monitoring</b>																																						
Single-phase mains																																						
Three-phase mains																																						
<b>Monitoring function</b>																																						
Phase failure																																						
Phase sequence																																						
Automatic phase sequence correction																																						
Overvoltage																																						
Undervoltage																																						
Unbalance																																						
Neutral																																						
Overfrequency																																						
Underfrequency																																						
<b>Thresholds</b>																																						
fix	fix	fix	fix	fix	fix	fix	fix	fix	fix	fix	fix	fix	fix	fix	fix	fix	fix	fix	fix	fix	fix	fix	fix	fix	fix	fix	fix	fix	fix	fix	fix	fix	fix	fix	fix	fix	fix	
<b>Timing functions for tripping delay</b>																																						
ON delay																																						
On and OFF delay	fix	fix	fix	fix	fix	fix																																
<b>Connection type</b>																																						
Push-in terminals																																						
Double-chamber cage connection terminals																																						





# Three-phase monitoring relays

## Ordering details

2



CM-PBE

2CDC 251 064 V0011



CM-PSS.41P

2CDC 251 064 V0011



CM-PAS.31P

2CDC 251 063 V0011

### Description

Only reliable and continuous monitoring of a three-phase network guarantees the trouble-free and economic operation of machines and installations.

### Ordering details

Rated control supply voltage = measuring voltage	Monitoring function	Neutral monitoring	Type	Order code	Price 1 pce	Weight (1 pce) kg (lb)
3x380-440 V AC, 220-240 V AC	Phase failure detection (Single- and three-phase)	■	CM-PBE <sup>1)</sup>	1SVR550881R9400		0.08 (0.17)
3x380-440 V AC			CM-PBE	1SVR550882R9500		0.08 (0.17)
3x320-460 V AC, 185-265 V AC	Over- / under-voltage and phase failure detection (Single- and three-phase)	■	CM-PVE <sup>1)</sup>	1SVR550870R9400		0.08 (0.17)
3x320-460 V AC			CM-PVE	1SVR550871R9500		0.08 (0.17)
3x208-440 V AC			CM-PFE <sup>2)</sup>	1SVR550824R9100		0.08 (0.17)
3x200-500 V AC	Phase sequence monitoring and phase failure detection (Three-phase)		CM-PFS <sup>2)</sup>	1SVR430824R9300		0.15 (0.33)
			CM-PFS.S <sup>3)</sup>	1SVR730824R9300		0.127 (0.280)
			CM-PFS.P <sup>3)</sup>	1SVR740824R9300		0.119 (0.262)
3x380 V AC	Over- / under-voltage with fixed threshold values $\pm 10\%$		CM-PSS.31S	1SVR730784R2300		0.132 (0.291)
			CM-PSS.31P	1SVR740784R2300		0.123 (0.271)
3x400 V AC			CM-PSS.41S	1SVR740784R3300		0.132 (0.291)
			CM-PSS.41P	1SVR730784R3300		0.123 (0.271)
3x160-300 V AC	Over- and under-voltage with adjustable threshold values (Three-phase)		CM-PVS.31S	1SVR730794R1300		0.141 (0.311)
			CM-PVS.31P	1SVR740794R1300		0.132 (0.291)
3x300-500 V AC			CM-PVS.41S	1SVR730794R3300		0.139 (0.306)
			CM-PVS.41P	1SVR740794R3300		0.131 (0.289)
3x200-400 V AC			CM-PVS.81S	1SVR730794R2300		0.136 (0.300)
			CM-PVS.81P	1SVR740794R2300		0.128 (0.282)
3x160-300 V AC	Phase unbalance (Three-phase)		CM-PAS.31S	1SVR730774R1300		0.133 (0.293)
			CM-PAS.31P	1SVR740774R1300		0.124 (0.273)
3x300-500 V AC			CM-PAS.41S	1SVR730774R3300		0.132 (0.291)
			CM-PAS.41P	1SVR740774R3300		0.123 (0.271)

<sup>1)</sup> The version with neutral monitoring is also suitable for monitoring single-phase mains. For this, all three external conductors (L1,L2,L3) have to be jumpered and connected as one single conductor.

<sup>2)</sup> For applications where a reverse fed voltage >60% is expected, we recommend to use our three-phase monitoring relays for unbalance CM-PAS.xx

<sup>3)</sup> new generation available 4th quarter 2012

# Three-phase monitoring relays

## Ordering details

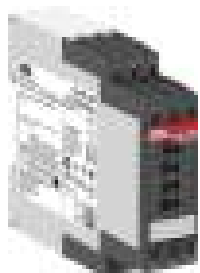

CM-MPS.23P

2CDC251 065 V0011



CM-MPN.52P

2CDC251 062 V0011

### Ordering details

Rated control supply voltage = measuring voltage	Monitoring function	Neutral monitoring	Type	Order code	Price 1 pce	Weight (1 pce) kg (lb)
90-170 V AC	Multifunctional (Three-phase phase failure detection, Phase sequence monitoring, overvoltage, undervoltage, Phase unbalance)	■	CM-MPS.11S	1SVR730885R1300		0.148 (0.326)
180-280 V AC			CM-MPS.11P	1SVR740885R1300		0.137 (0.302)
			CM-MPS.21S	1SVR730885R3300		0.146 (0.322)
			CM-MPS.21P	1SVR740885R3300		0.135 (0.298)
		3x300-500 V AC	CM-MPS.31S	1SVR730884R1300		0.142 (0.313)
CM-MPS.31P			1SVR740884R1300		0.133 (0.293)	
CM-MPS.41S			1SVR730884R3300		0.140 (0.309)	
CM-MPS.41P			1SVR740884R3300		0.132 (0.291)	
180-280 V AC	Multifunctional (Three-phase phase failure detection, Phase sequence monitoring, overvoltage, undervoltage, Phase unbalance)	■	CM-MPS.23S	1SVR730885R4300		0.149 (0.328)
3x300-500 V AC			CM-MPS.23P	1SVR740885R4300		0.138 (0.304)
		3x350-580 V AC	CM-MPS.43S	1SVR730884R4300		0.148 (0.327)
CM-MPS.43P			1SVR740884R4300		0.137 (0.302)	
3x450-720 V AC		CM-MPN.52S	1SVR750487R8300		0.230 (0.507)	
		CM-MPN.52P	1SVR760487R8300		0.226 (0.498)	
3x530-820 V AC		CM-MPN.62S	1SVR750488R8300		0.229 (0.505)	
		CM-MPN.62P	1SVR760488R8300		0.225 (0.496)	
3 x 400 V AC (L-L) / 230 V AC (L-N)		CM-MPN.72S	1SVR750489R8300		0.224 (0.494)	
		CM-MPN.72P	1SVR760489R8300		0.220 (0.485)	
24-240 V AC/DC	see Three-phase overview page	■	CM-UFS.2	1SVR630736R1300		0.140 (0.309)
			CM-UFD.M21	1SVR510730R0300		0.225 (0.496)

# Three-phase monitoring relays

## Function diagrams

2

### Function diagrams - Three-phase monitoring CM-PBE

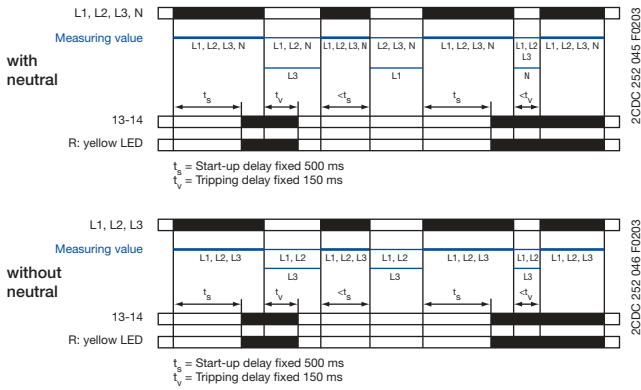

If all phases (and the neutral) are present, the output relay energizes after the start-up delay  $t_s$  is complete. If a phase failure occurs, the tripping delay  $t_v$  starts. When timing is complete, the output relay de-energizes. As soon as the voltage returns to the tolerance range, timing of  $t_s$  starts. When timing is complete, the output relay re-energizes automatically. The yellow LED glows when the output relay is energized.

### Function diagrams - Three-phase monitoring CM-PVE

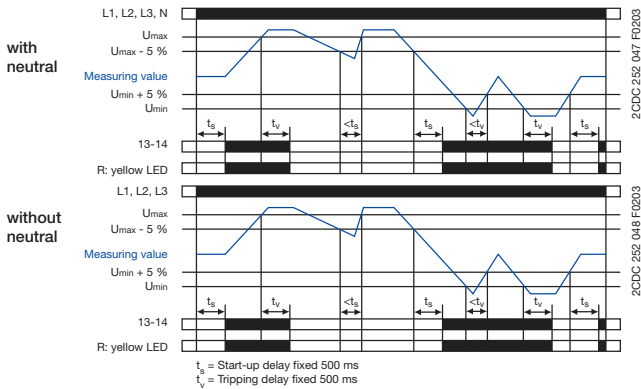

If all phases (and the neutral) are present with correct voltage, the output relay energizes after the start-up delay  $t_s$  is complete. If the voltage exceeds or falls below the fixed threshold value or if a phase failure occurs, the tripping delay  $t_v$  starts. When timing is complete, the output relay de-energizes. As soon as the voltage returns to the tolerance range, timing of  $t_s$  starts. When timing is complete, the output relay re-energizes automatically. The yellow LED glows when the output relay is energized.

### Function diagram - CM-PFE

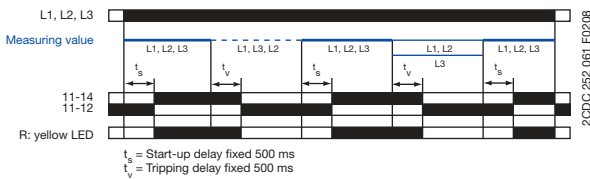

If all phases are present with the correct phase sequence, the output relay energizes after the start-up delay  $t_s$  is complete. If a phase failure or a phase sequence error occurs, the tripping delay  $t_v$  starts. When timing is complete, the output relay de-energizes. The yellow LED glows when the output relay is energized.

In case of motors which continue running with only two phases, the CM-PFE detects phase failure if the reverse fed voltage is less than 60 % of the originally applied voltage.

### Function diagram - CM-PFS

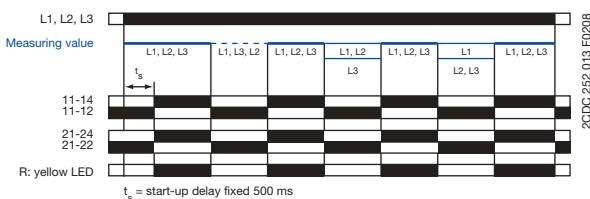

If all phases are present with the correct phase sequence, the output relay energizes after the start-up delay  $t_s$  is complete. If a phase failure or a phase sequence error occurs, the output relay de-energizes instantaneously. The yellow LED glows when the output relay is energized.

In case of motors which continue running with only two phases, the CM-PFS detects phase failure if the reverse fed voltage is less than 60 % of the originally applied voltage.

#### ATTENTION

If several CM-PFS units are placed side by side and the control supply voltage is higher than 415 V, spacing of at least 10 mm has to be kept between the individual units.

# Three-phase monitoring relays

## Function diagrams

### Phase sequence and phase failure monitoring

CM-PSS.xx, CM-PVS.xx, CM.PAS.xx, CM-MPS.xx, CM-MPN.xx

Applying control supply voltage begins the fixed start-up delay  $t_s$ . When  $t_s$  is complete and all phases are present with correct voltage, the output relays energize and the yellow LED R/T glows.

### Phase sequence monitoring

If phase sequence monitoring is activated, the output relays de-energize as soon as a phase sequence error occurs. The fault is displayed by alternated flashing of the LEDs F1 and F2. The output relays re-energize automatically as soon as the phase sequence is correct again.

### Phase failure monitoring

The output relays de-energize instantaneous if a phase failure occurs. The fault is indicated by lighting of LED F1 and flashing of LED F2. The output relays re-energize automatically as soon as the voltage returns to the tolerance range.

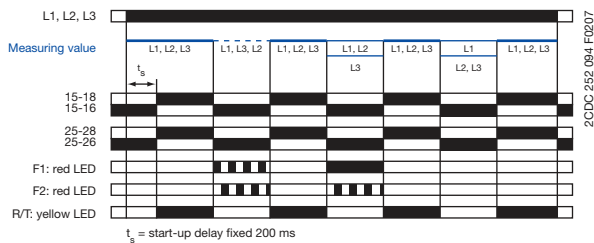

### Interrupted neutral monitoring

CM-MPS.11, CM-MPS.21, CM-MPS.23

The interruption of the neutral in the main to be monitored is detected by means of phase unbalance evaluation.

Determined by the system, in case of unloaded neutral, i.e. symmetrical load between all three phases, it may happen that an interruption of the neutral will not be detected.

If the star point is displaced by asymmetrical load in the three-phase main, an interrupted neutral will be detected.

### Displacement of the star point

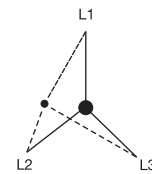

### Automatic phase sequence correction

CM-MPS.x3, CM-MPN.x2

This function can be selected only if phase sequence monitoring is activated and operating mode 2x1 c/o (SPDT) contact is selected.

Applying control supply voltage begins the fixed start-up delay  $t_{s1}$ . When  $t_{s1}$  is complete and all phases are present with correct voltage, output relay R1 energizes. Output relay R2 energizes when the fixed start-up delay  $t_{s2}$  is complete and all phases are present with correct phase sequence. Output relay R2 remains de-energized if the phase sequence is incorrect.

If the voltage to be monitored exceeds or falls below the set threshold values for phase unbalance, over- or undervoltage or if a phase failure occurs, output relay R1 de-energizes and the LEDs F1 and F2 indicate the fault.

Output relay R2 is responsive only to a false phase sequence. In conjunction with a reversing contactor combination, this enables an automatic correction of the rotation direction. See circuit diagrams on the right.

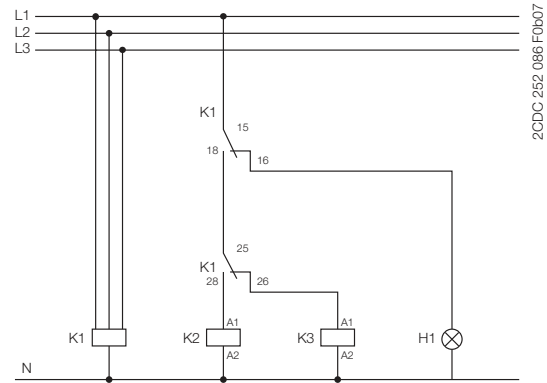
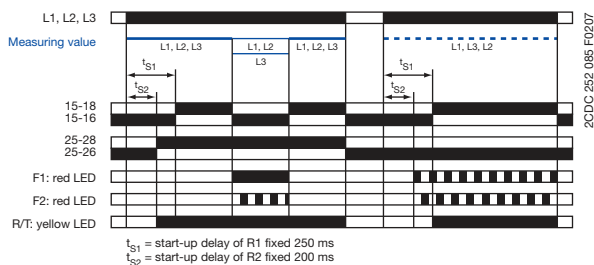

Control circuit diagram (K1 = CM-MPS.xx or CM-MPN.xx)

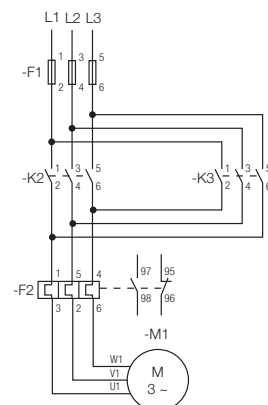

Power circuit diagram

# Three-phase monitoring relays

## Function diagrams

2

### Over- and undervoltage monitoring 1x2 c/o

CM-PSS.xx<sup>1</sup>, CM-PVS.xx<sup>2</sup>, CM-MPS.xx<sup>2</sup>, CM-MPN.xx<sup>2</sup>

Applying control supply voltage begins the fixed start-up delay  $t_s$ . When  $t_s$  is complete and all phases are present with correct voltage and with correct phase sequence, the output relays energize and the yellow LED R/T glows.

#### Type of tripping delay = ON-delay

If the voltage to be monitored exceeds or falls below the fixed<sup>1</sup> or set<sup>2</sup> threshold value, the output relays de-energize after the set tripping delay  $t_v$  is complete. The LED R/T flashes during timing and turns off as soon as the output relays de-energize.

The output relays re-energize automatically as soon as the voltage returns to the tolerance range, taking into account a fixed hysteresis of 5% and the LED R/T glows.

#### Type of tripping delay = OFF-delay

If the voltage to be monitored exceeds or falls below the fixed<sup>1</sup> or set<sup>2</sup> threshold value, the output relays de-energize instantaneously and the LED R/T turns off.

As soon as the voltage returns to the tolerance range, taking into account a fixed hysteresis of 5%, the output relays re-energize automatically after the set tripping delay  $t_v$  is complete. The LED R/T flashes during timing and turns steady when timing is complete.

### ON-delay 1x2 c/o contacts 1x2 c/o

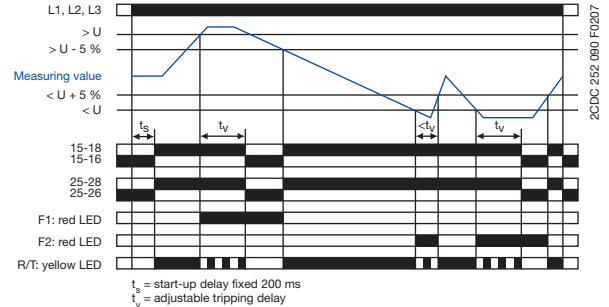

### OFF-delay 1x2 c/o contacts 1x2 c/o

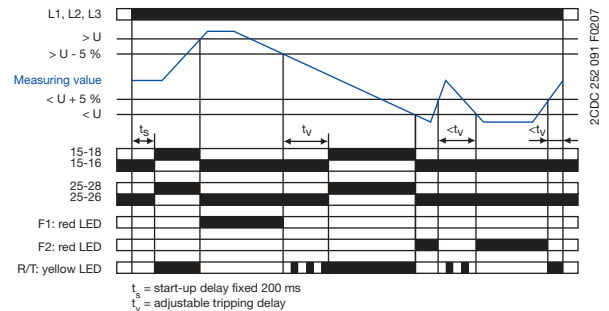

### Over- and undervoltage monitoring 2x1 c/o

CM-MPS.x3, CM-MPN.x2

Applying control supply voltage begins the fixed start-up delay  $t_s$ . When  $t_s$  is complete and all phases are present with correct voltage and with correct phase sequence, the output relays energize. The yellow LED R/T glows as long as at least one output relay is energized.

#### Type of tripping delay = ON-delay

If the voltage to be monitored exceeds or falls below the set threshold value, output relay R1 (overvoltage) or output relay R2 (undervoltage) de-energizes after the set tripping delay  $t_v$  is complete. The LED R/T flashes during timing.

The corresponding output relay re-energizes automatically as soon as the voltage returns to the tolerance range, taking into account a fixed hysteresis of 5%.

#### Type of tripping delay = OFF-delay

If the voltage to be monitored exceeds or falls below the set threshold value, output relay R1 (overvoltage) or output relay R2 (undervoltage) de-energizes instantaneously.

As soon as the voltage returns to the tolerance range, taking into account a fixed hysteresis of 5%, the corresponding output relay re-energizes automatically after the set tripping delay  $t_v$  is complete. The LED R/T flashes during timing.

### ON-delay 2x1 c/o contact 2x1 c/o

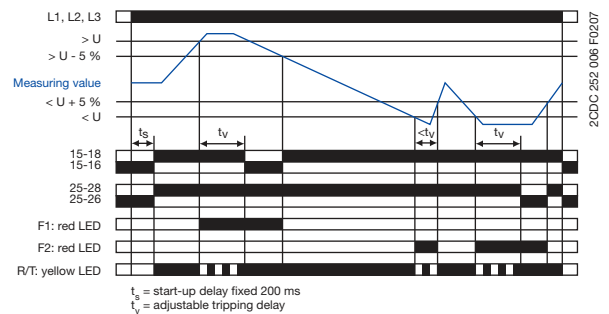

### OFF-delay 2x1 c/o contact 2x1 c/o

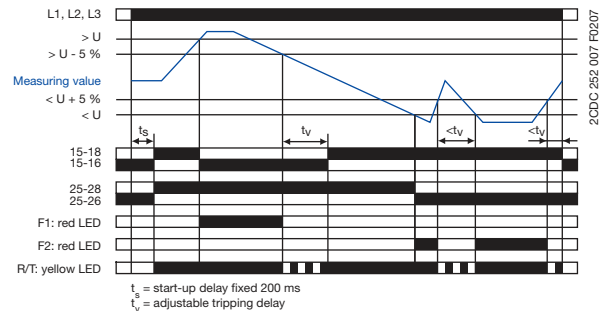

# Three-phase monitoring relays

## Function diagrams

### Phase unbalance monitoring CM-PAS.xx, CM-MPS.xx, CM-MPN.xx

Applying control supply voltage begins the fixed start-up delay  $t_s$ . When  $t_s$  is complete and all phases are present with correct voltage and with correct phase sequence, the output relays energize and the yellow LED R/T glows.

#### Type of tripping delay = ON-delay

If the voltage to be monitored exceeds or falls below the set phase unbalance threshold value, the output relays de-energize after the set tripping delay  $t_v$  is complete. The LED R/T flashes during timing and turns off as soon as the output relays de-energize.

The output relays re-energize automatically as soon as the voltage returns to the tolerance range, taking into account a fixed hysteresis of 20 % and the LED R/T glows.

#### Type of tripping delay = OFF-delay

If the voltage to be monitored exceeds or falls below the set phase unbalance threshold value, the output relays de-energize instantaneously and the LED R/T turns off.

As soon as the voltage returns to the tolerance range, taking into account a fixed hysteresis of 20 %, the output relays re-energize automatically after the set tripping delay  $t_v$  is complete. The LED R/T flashes during timing and turns steady when timing is complete.

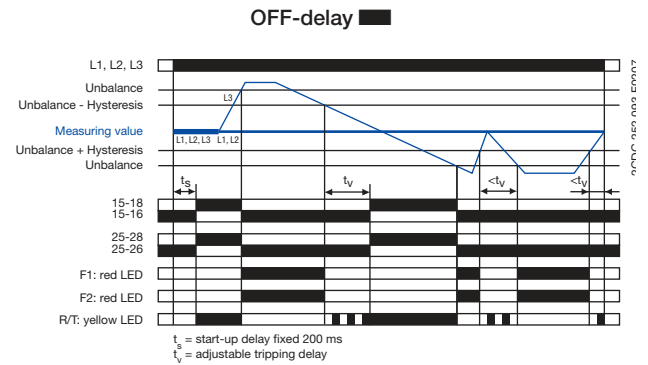
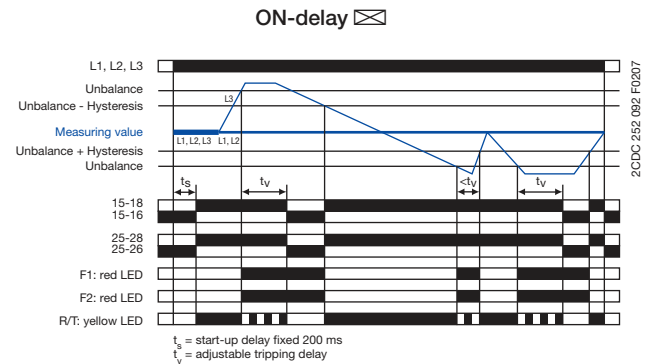

### LED functions CM-PSS.xx, CM-PSV.xx, CM-PAS.xx, CM-MPS.xx, CM-MPN.xx

Function	R/T: yellow LED	F1: red LED	F2: red LED
Control supply voltage applied, output relay energized		-	-
Tripping delay $t_v$ active		-	-
Phase failure	-		
Phase sequence	-		
Overvoltage	-		-
Undervoltage	-	-	
Phase unbalance	-		
Interruption of the neutral	-		
Adjustment error <sup>1)</sup>			

<sup>1)</sup> Possible misadjustments of the front-face operating controls:

Overlapping of the threshold values: An overlapping of the threshold values is given, if the threshold value for overvoltage is set to a smaller value than the threshold value for undervoltage.

DIP switch 3 = OFF and DIP switch 4 = ON: Automatic phase sequence correction is activated and selected operating mode is 1x2 c/o contacts

DIP switch 2 and 4 = ON: Phase sequence detection is deactivated and the automatic phase sequence correction is activated

### Type of tripping delay CM-PSS.xx, CM-PSV.xx, CM-PAS.xx, CM-MPS.xx, CM-MPN.xx

The type of tripping delay ☒ / ■ can be adjusted via a rotary (CM-PxS.xx) or a DIP switch (CM-MPx.xx).

#### Switch position ON-delay ☒:

In case of a fault, the de-energizing of the output relays and the respective fault message are suppressed for the adjusted tripping delay  $t_v$ .

#### Switch position OFF-delay ■:

In case of a fault, the output relays de-energize instantaneously and a fault message is displayed and stored for the length of the adjusted tripping delay  $t_v$ . Thereby, also momentary undervoltage conditions are recognized.

# Three-phase monitoring relays

## Function diagrams

### Grid feeding monitoring CM-UFS.2

#### Function of the yellow LED

The yellow LED is flashing during timing and turns steady as soon as the output relays are energized.

2

#### Phase failure monitoring

Applying control supply voltage begins the fixed start-up delay  $t_{S1}$ . When  $t_{S1}$  is complete and all phases are present with correct voltage and frequency, the output relays energize. They de-energize instantaneously if a phase failure occurs. The fault is indicated by LEDs.

As soon as all 3 phases are present again, the output relays re-energize automatically after the set restart delay  $t_{S2}$  is complete.

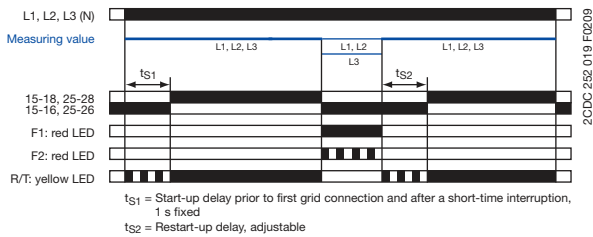

#### Over- and underfrequency monitoring

Applying control supply voltage begins the fixed start-up delay  $t_{S1}$ . When  $t_{S1}$  is complete and all phases are present with correct voltage and frequency, the output relays energize.

If the frequency to be monitored exceeds or falls below the fixed threshold value, the output relays deenergize instantaneously. The fault type is indicated by LEDs. As soon as the frequency returns to the tolerance range, taking into account a fixed hysteresis, the output relays re-energize after the set restart delay  $t_{S2}$  is complete.

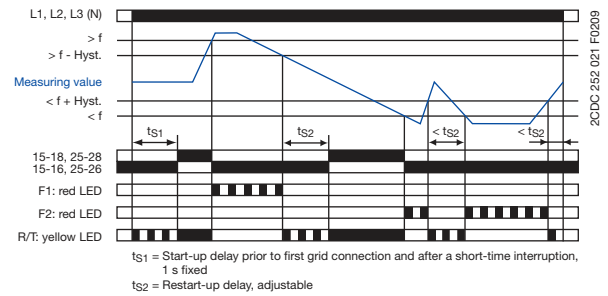

#### Over- and undervoltage monitoring

Applying control supply voltage begins the fixed start-up delay  $t_{S1}$ . When  $t_{S1}$  is complete and all phases are present with correct voltage and frequency, the output relays energize.

If the voltage to be monitored exceeds or falls below the fixed threshold value, the output relays de-energize instantaneously. The fault type is indicated by LEDs. As soon as the voltage returns to the tolerance range, taking into account a fixed hysteresis of 5 %, the output relays re-energize after the set restart delay  $t_{S2}$  is complete.

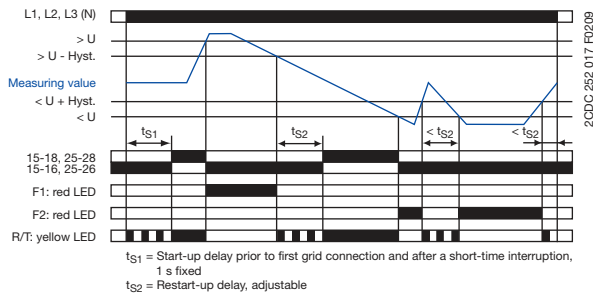

#### Function diagram legend

- Control supply voltage not applied / Output contact open / LED off
- Control supply voltage applied / Output contact closed / LED glowing

#### LED Funktionen

Function	R/T: yellow LED	F1: red LED	F2: red LED
Output relay energized	■	-	-
Delay active	▬	-	-
Overvoltage	-	▬	-
Undervoltage	-	-	▬
Overfrequency	-	▬	-
Underfrequency	-	-	▬
Phase failure	-	▬	▬

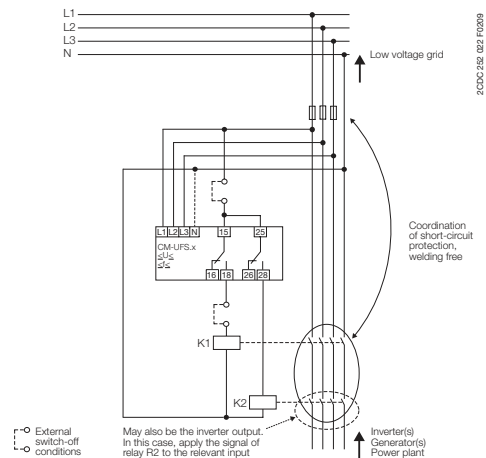

Automatized grid connection instead of a permanently accessible switching point with a disconnection function

# Three-phase monitoring relays

## Connection diagrams, DIP switches

Connection diagrams CM-PBE

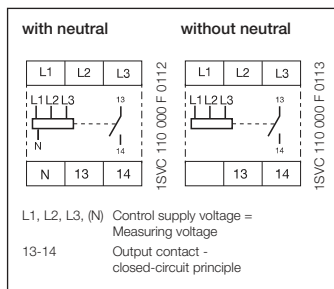

Connection diagram CM-PVS.x1

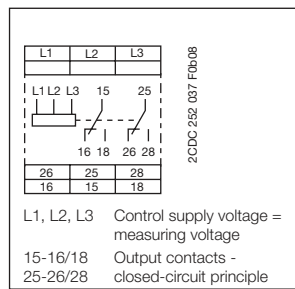

Connection diagram CM-PFS

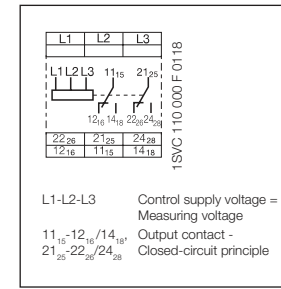

Rotary switch "Function" CM-PVS

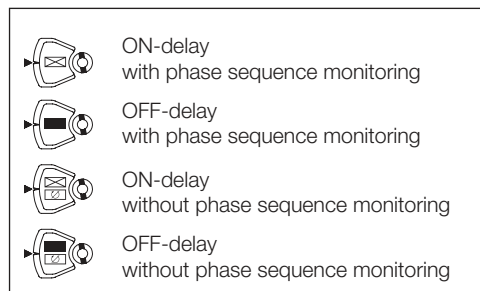

Connection diagrams CM-PVE

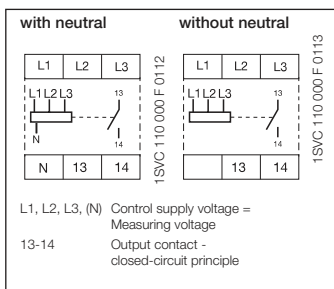

Connection diagram CM-PSS.x1

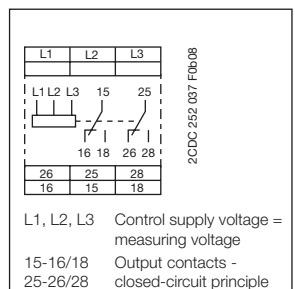

Connection diagram CM-PFE

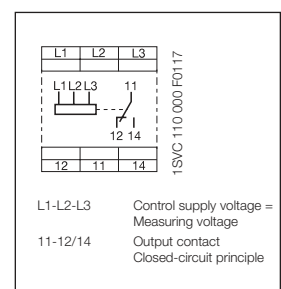

Rotary switch "Function" CM-PSS

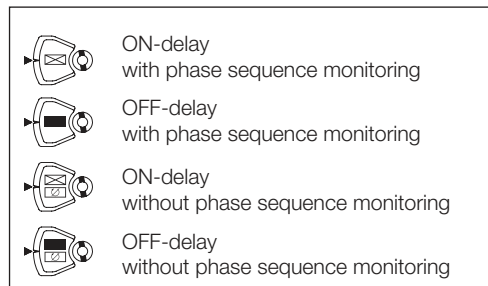

Connection diagram CM-UFS.2

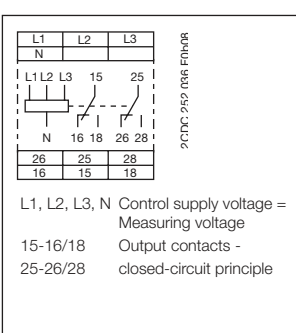

Connection diagram CM-MPN.x2

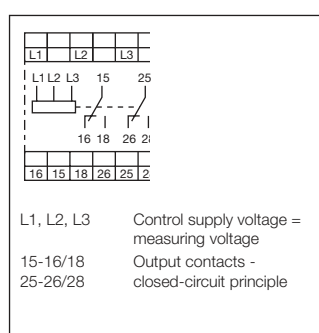

Connection diagram CM-PAS.x1

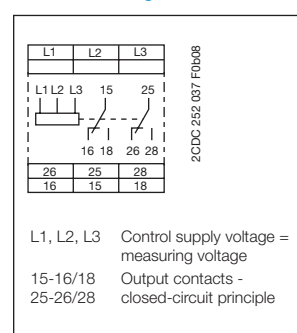



# Three-phase monitoring relays

## Connection diagrams, DIP switches, Rotary switches

2

### Connection diagram CM-MPS.x3

L1, L2, L3, (N) Control supply voltage = measuring voltage  
 15-16/18 Output contacts - closed-circuit principle  
 25-26/28

### DIP switch functions CM-MPS.x3 and CM-MPN.x2

Position	4	3	2	1
ON ↑				
OFF				

2CDC 252 041 F0008

**1 Timing function**  
 ON ON-delayed  
 OFF OFF-delayed

**2 Phase sequence monitoring**  
 ON deactivated  
 OFF activated

**3 Operating principle of output**  
 ON 2x1 c/o contact  
 OFF 1x2 c/o contacts

**4 Phase sequence correction**  
 ON activated  
 OFF deactivated

<sup>1)</sup> Output relay R1 is responsive to overvoltage, output relay R2 is responsive to undervoltage. In case of other faults, both output relays react synchronously.

### Connection diagram CM-MPS.x1

L1, L2, L3, (N) Control supply voltage = measuring voltage  
 15-16/18 Output contacts - closed-circuit principle  
 25-26/28

### DIP switch functions CM-MPS.x1

Position	2	1
ON ↑		
OFF		

2CDC 252 040 F0008

**1 Timing function**  
 ON ON-delayed  
 OFF OFF-delayed

**2 Phase sequence monitoring**  
 ON deactivated  
 OFF activated



# Three-phase monitoring relays

## Technical data

Data at  $T_a = 25\text{ °C}$  and rated values, unless otherwise indicated

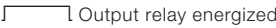
Type	CM-PBE <sup>1)</sup>	CM-PBE	CM-PVE <sup>1)</sup>	CM-PVE	CM-PFE	CM-PFS <sup>2)</sup>
<b>Supply circuit = measuring circuit</b>	<b>L1-L2-L3-N</b>	<b>L1-L2-L3</b>	<b>L1-L2-L3-N</b>	<b>L1-L2-L3</b>	<b>L1-L2-L3</b>	
Rated control supply voltage $U_s =$ measuring voltage	3x380-440 V AC, 220-240 V AC	3x380-440 V AC	3x320-460 V AC, 185-265 V AC	3x320-460 V AC	3x208-440 V AC	3x200-500 V AC
Power consumption					approx. 15 VA	
Rated control supply voltage $U_s$ tolerance	-15...+15 %		-15...+10 %		-10...+10 %	-15...+10 %
Rated frequency	50/60 Hz		50/60 Hz (-10...+10 %)			50/60 Hz
Duty time	100 %					
Measuring circuit	L1-L2-L3-N	L1-L2-L3	L1-L2-L3-N	L1-L2-L3	L1-L2-L3	
Monitoring functions	phase failure ■	■	■	■	■	■
	phase sequence -	-	-	-	■	■
	over- / undervoltage -	-	■	■	-	-
	neutral ■	-	-	-	-	-
Measuring ranges	3x380-440 V AC, 220-240 V AC	3x380-440 V AC	3x320-460 V AC, 185-265 V AC	3x320-460 V AC	3x208-440 V AC	3x200-500 V AC
Thresholds	$U_{min}$ $U_{max}$	0.6 x UN	fixed 185 V / 320 V	fixed 320 V	0.6 x UN	
Hysteresis related to the threshold value	fixed 5 % (release value = 0.65 x UN)		fixed 5 %			
Measuring voltage frequency	50/60 Hz (-10 %...+10 %)				50/60 Hz	
Response time	40 ms		80 ms		500 ms	
Accuracy within the rated control supply voltage tolerance					$\Delta U \leq 0.5\ %$	
Accuracy within the temperature range					$\Delta U \leq 0.06\ \% / \text{°C}$	
<b>Timing circuit</b>						
Start-up delay $t_s$	fixed 500 ms ( $\pm 20\ %$ )				fixed 500 ms	
Tripping $t_v$	fixed 150 ms ( $\pm 20\ %$ )		at over- / undervoltage fixed 500 ms ( $\pm 20\ %$ )		fixed 500 ms -	
<b>Indication of operational states</b>						
Relay status	R: yellow LED	 Output relay energized				
<b>Output circuits</b>	13-14				11-12/14	11(15)-12(16)/14(18), 21(25)-22(26)/24(28)
Kind of output	1 n/o contact				1 c/o contact	2 c/o contacts
Operating principle <sup>3)</sup>	closed-circuit principle					
Contact material	AgCdO					AgNi
Rated operational voltage $U_n$	IEC/EN 60947-1 250 V					
Minimum switching voltage / Minimum switching current	- / -					
Maximum switching voltage	250 V AC, 250 V DC					
Rated operational current $I_n$	AC12 (resistive) 230 V 4 A					
(IEC/EN 60947-5-1)	AC15 (inductive) 230 V 3 A					
	DC12 (resistive) 24 V 4 A					
	DC13 (inductive) 24 V 2 A					
Mechanical lifetime	30 x 10 <sup>6</sup> switching cycles					
Electrical lifetime (AC12, 230 V, 4 A)	0.1 x 10 <sup>6</sup> switching cycles					
Max. fuse rating to achieve short-circuit protection	n/c contact	10 A fast-acting				4 A fast-acting
	n/o contact	10 A fast-acting				6 A fast-acting
AC rating (UL 508)	Utilization category (Control Circuit Rating Code)	B 300				
	max. rated operational voltage	300 V AC				
	max. continuous thermal current at B 300	5 A				
	max. making/breaking apparent power at B 300	3600/360 VA				

<sup>1)</sup> Device with neutral monitoring: The external conductor voltage towards the neutral conductor is measured.

<sup>2)</sup> CM-PFS.S/P in new housing do vary in several technical data. Please refer to the data sheet.

<sup>3)</sup> Closed-circuit principle: Output relay is de-energized if the measured value exceeds/drops below the adjusted threshold.

# Three-phase monitoring relays

## Technical data

Data at  $T_a = 25\text{ °C}$  and rated values, unless otherwise indicated

Type	CM-PBE <sup>1)</sup>	CM-PBE	CM-PVE <sup>1)</sup>	CM-PVE	CM-PFE	CM-PFS
<b>General data</b>						
Dimensions (W x H x D)	22.5 x 78 x 78.5 mm (0.89 x 3.07 x 3.09 in)					22.5 x 78 x 100 mm (0.89 x 3.07 x 3.94 in)
Weight	see data sheet					
Mounting	DIN rail (IEC/EN 60715)					
Mounting position	any					
Degree of protection	housing / terminals	IP50 / IP20				
<b>Electrical connection</b>						
Wire size	fine-strand with wire end ferrule	2 x 0.75-1.5 mm <sup>2</sup> (2 x 18-16 AWG)				2 x 0.75- 2.5 mm <sup>2</sup> (2 x 8-14 AWG)
	fine-strand without wire end ferrule	2 x 1-1.5 mm <sup>2</sup> (2 x 18-16 AWG)				
	rigid	2 x 0.75-1.5 mm <sup>2</sup> (2 x 18-16 AWG)				2 x 0.5- 4 mm <sup>2</sup> (2 x 20-12 AWG)
Stripping length		10 mm (0.39 in)				7 mm (0.28 in)
Tightening torque		0.6-0.8 Nm				
<b>Environmental data</b>						
Ambient temperature range	operation / storage	-20...+60 °C / -40...+85 °C				
Environmental testing (IEC 68-2-30)		24 h cycle time, 55 °C, 93 % rel., 96 h				
Operational reliability (IEC 68-2-6)		6 g				4 g
Mechanical resistance (IEC 68-2-6)		10 g				6 g
<b>Isolation data</b>						
Rated insulation volt. between supply, measuring and output circuits (VDE 0110, IEC 60947-1)		400 V			500 V	
Rated impulse withstand voltage $U_{imp}$ between all isolated circuits (VDE 0110, IEC 664)		4 kV / 1.2 - 50 µs				
Test voltage between all isolated circuits		2.5 kV, 50 Hz, 1 min.				
Pollution category (VDE 0110, IEC/EN 60664, IEC 255-5)		3				
Overvoltage category (VDE 0110, IEC/EN 60664, IEC 255-5)		III				
<b>Standards</b>						
Product standard		IEC 255-6, EN 60255-6				
Low Voltage Directive		2006/95/EC				
EMC Directive		2004/108/EC				
<b>Electromagnetic compatibility</b>						
Interference immunity to		EN 61000-6-2				
electrostatic discharge	IEC/EN 61000-4-2	Level 3 - 6 kV/ 8 kV				
radiated, radio-frequency, electromagnetic field	IEC/EN 61000-4-3	Level 3 - 10 V/m				
electrical fast transient / burst	IEC/EN 61000-4-4	Level 3 - 2 kV / 5 kHz				
surge	IEC/EN 61000-4-5	Level 4 - 2 kV-L				
conducted disturbances, induced by radio-frequency fields	IEC/EN 61000-4-6	Level 3 - 10 V				
Interference emission		EN 61000-6-4				

<sup>1)</sup> Device with neutral monitoring: The external conductor voltage towards the neutral conductor is measured.

# Three-phase monitoring relays

## Technical data

Data at  $T_a = 25\text{ °C}$  and rated values, unless otherwise indicated

Type	CM-PSS.31	CM-PSS.41	CM-PVS.31	CM-PVS.41	CM-PVS.81	CM-PAS.31	CM-PAS.41
<b>Input circuit = Measuring circuit</b>							
<b>L1, L2, L3</b>							
Rated control supply voltage $U_s$ = measuring voltage	3x380 V AC	3x400 V AC	3x160-300 V AC	3x300-500 V AC	3x200-400 V AC	3x160-300 V AC	3x300-500 V AC
Rated control supply voltage $U_s$ tolerance	-15...+10 %						
Rated frequency	50/60 Hz						
Frequency range	45-65 Hz						
Typical current / power consumption	25 mA / 18 VA (380 V AC)	25 mA / 18 VA (400 V AC)	25 mA / 10 VA (230 V AC)	25 mA / 18 VA (400 V AC)	19 mA / 10 VA (300 V AC)	25 mA / 10 VA (230 V AC)	25 mA / 18 VA (400 V AC)
<b>Measuring circuit</b>							
<b>L1, L2, L3</b>							
Monitoring functions	■	■	■	■	■	■	■
Phase failure	can be switched off						
Phase sequence	-						
Automatic phase sequence correction	-	-	-	-	-	-	-
Over- / undervoltage	■	■	■	■	■	-	-
Phase unbalance	-	-	-	-	-	■	■
Neutral	-	-	-	-	-	-	-
Measuring range	Overvoltage	3x418 V AC	3x440 V AC	3x220-300 V AC	3x420-500 V AC	3x300-400 V AC	-
	Undervoltage	3x342 V AC	3x360 V AC	3x160-230 V AC	3x300-380 V AC	3x210-300 V AC	-
	Phase unbalance	-	-	-	-	-	2-25 % of average of phase voltages
Thresholds	Overvoltage	fixed	-	adjustable within measuring range	-	-	-
	Undervoltage	fixed	-	adjustable within measuring range	-	-	-
	Phase unbalance (switch-off value)	-	-	-	-	-	adjust. within meas. range
Hysteresis related to the threshold value	Over- / undervoltage	fixed 5 %	-	-	-	-	-
	Phase unbalance	-	-	-	-	-	fixed 20 %
Rated frequency of the measuring signal	50/60 Hz						
Frequency range of the measuring signal	45-65 Hz						
Maximum measuring cycle time	100 ms						
Accuracy within the rated control supply voltage tolerance	$\Delta U \leq 0.5\%$						
Accuracy within the temperature range	$\Delta U \leq 0.06\% / \text{°C}$						
Measuring method	True RMS						
<b>Timing circuit</b>							
Start-up delay $t_s$	fixed 200 ms						
Tripping delay $t_v$	ON- or OFF-delay 0; 0.1-30 s adjustable					ON- delay 0; 0.1-30 s adjustable	
Repeat accuracy (constant parameters)	-						
Accuracy within the rated control supply voltage tolerance	$\Delta t \leq 0.5\%$						
Accuracy within the temperature range	$\Delta t \leq 0.06\% / \text{°C}$						
Indication of operational states	-			1 yellow LED, 2 red LED's		-	
	Details see function description / -diagrams		Details see operating mode and function description / -diagrams			Details see function description / -diagrams	
<b>Output circuits</b>							
<b>15-16/18, 25-26/28</b>							
Kind of output	2x1 c/o contacts (Relays)						
Operating principle <sup>1)</sup>	closed-circuit principle						
Contact material	AgNi alloy, Cd free						
Rated operational voltage $U_a$	IEC/EN 60947-1 250 V						
Minimum switching power	24 V / 10 mA						
Maximum switching voltage	see load limit curve						

<sup>1)</sup> Closed-circuit principle: Output relay(s) de-energize(s) if measured value exceeds or falls below the adjusted threshold value

# Three-phase monitoring relays

## Technical data

Data at  $T_a = 25\text{ °C}$  and rated values, unless otherwise indicated

Type		CM-PSS.31	CM-PSS.41	CM-PVS.31	CM-PVS.41	CM-PVS.81	CM-PAS.31	CM-PAS.41	
Rated operational current $I_o$ (IEC/EN 60947-5-1)	AC12 (resistive) 230 V	4 A							
	AC15 (inductive) 230 V	3 A							
	DC12 (resistive) 24 V	4 A							
	DC13 (inductive) 24 V	2 A							
	Utilization category (Control Circuit Rating Code)	B 300							
AC rating (UL 508)	max. rated operational voltage	300 V AC							
	max. continuous thermal current at B 300	5 A							
	max. making/breaking apparent power at B 300	3600/360 VA							
Mechanical lifetime	30 x 10 <sup>6</sup> switching cycles								
Electrical lifetime (AC12, 230 V, 4 A)	0.1 x 10 <sup>6</sup> switching cycles								
Max. fuse rating to achieve short-circuit protection	n/c contact	6 A fast-acting							
	n/o contact	10 A fast-acting							
<b>General data <sup>1)</sup></b>									
MTBF								on request	
Duty time								100%	
Dimensions (W x H x D)	product dimensions	22.5 x 85.6 x 103.7 mm (0.89 x 3.37 x 4.08 in)							
	packaging dimensions	97 x 109 x 30 mm (3.82 x 4.29 x 1.18 in)							
Weight								depending on device, see ordering details	
Mounting								DIN rail (IEC/EN 60715), snap-on mounting without any tool	
								any	
Mounting position								any	
Minimum distance to other units	vertical / horizontal	not necessary / not necessary							
Material of housing								UL 94 V-0	
Degree of protection	housing / terminals								IP50 / IP20
<b>Electrical connection <sup>1)</sup></b>									
Wire size			<b>Screw connection technology</b>			<b>Easy Connect Technology (Push-in)</b>			
	fine-strand with(out) wire end ferrule	input circuit	1 x 0.5-2.5 mm <sup>2</sup> (1 x 20-14 AWG)			2 x 0.5-1.5 mm <sup>2</sup> (2 x 20-16 AWG)			
		output circuit 1 / output circuit 2	2 x 0.5-1.5 mm <sup>2</sup> (2 x 20-16 AWG)						
	rigid	input circuit	1 x 0.5-4 mm <sup>2</sup> (1 x 20-12 AWG)			2 x 0.5-1.5 mm <sup>2</sup> (2 x 20-16 AWG)			
		output circuit	2 x 0.5-2.5 mm <sup>2</sup> (2 x 20-14 AWG)						
Stripping length			8 mm (0.32 in)						
Tightening torque			0.6-0.8 Nm (5.31-7.08 lb.in)						
<b>Environmental data</b>									
Ambient temperature ranges	operation / storage	-25...+60 °C / -40...+85 °C							
Damp heat (IEC 60068-2-30)	55 °C, 6 cycles								
Climatic category	3K3								
Vibration (sinusoidal) (IEC/EN 60255-21-1)	Class 2								
Shock (IEC/EN 60255-21-2)	Class 2								
<b>Isolation data <sup>1)</sup></b>									
Rated insulation voltage $U_i$	input circuit / output circuit	600 V							
	output circuit 1 / output circuit 2	300 V							
Rated impulse withstand voltage $U_{imp}$ (VDE 0110, IEC/EN 60664)	input circuit	6 kV; 1.2/50 $\mu$ s							
	output circuit	4 kV; 1.2/50 $\mu$ s							
Test voltage between all isolated circuits (type test)	2.5 kV, 50 Hz, 1 s								
Basis insulation	input circuit / output circuit	600 V							
	input circuit / output circuit	-							
Protective separation (VDE 0106 part 101 and 101/A, IEC/EN 1140)	input circuit / output circuit	-							
Pollution degree (VDE 0110, IEC/EN 60664)	3								
Overvoltage category (VDE 0110, IEC 60664)	III								
<b>Standards <sup>1)</sup></b>									
Product standard	IEC/EN 60255-6, EN 50178								
Low Voltage Directive	2006/95/EG								
EMC directive	2004/108/EG								
RoHS directive	2002/95/EG								
<b>Electromagnetic compatibility</b>									
Interference immunity to		EN 61000-6-1, EN 61000-6-2							
electrostatic discharge	IEC/EN 61000-4-2	Level 3 (6 kV / 8 kV)							
radiated, radio-frequency, electromagnetic field	IEC/EN 61000-4-3	Level 3 (10 V/m)							
electrical fast transient / burst	IEC/EN 61000-4-4	Level 3 (2 kV / 2 kHz)							
surge	IEC/EN 61000-4-5	Level 4 (2 kV L-L)							
conducted disturbances, induced by radio-frequency fields	IEC/EN 61000-4-6	Level 3 (10 V)							
Interference emission		Class 3							
high-frequency radiated	IEC/CISPR 22, EN 50022	EN 61000-6-3, EN 61000-6-4							
high-frequency conducted	IEC/CISPR 22, EN 50022	Class B							

<sup>1)</sup> Data for devices 1SVR 730 xxx xxx, 1SVR 740 xxx xxx, 1SVR 750 xxx xxx, 1SVR 760 xxx xxx. For devices 1SVR x30 xxx xxx, 1SVR x50 xxx xxx refer to the data sheet.

# Three-phase monitoring relays

## Technical data

Data at  $T_a = 25\text{ °C}$  and rated values, unless otherwise indicated

Type	CM-MPS.11	CM-MPS.21	CM-MPS.31	CM-MPS.41
<b>Input circuit = Measuring circuit</b>				
	<b>L1, L2, L3, N</b>		<b>L1, L2, L3</b>	
Rated control supply voltage $U_s =$ measuring voltage	3x90-170 V AC	3x180-280 V AC	3x160-300 V AC	3x300-500 V AC
Rated control supply voltage $U_s$ tolerance	-15...+10 %			
Rated frequency	50/60 Hz			
Frequency range	45-65 Hz			
Typical current / power consumption	25 mA / 10 VA (115 V AC)	25 mA / 18 VA (230 V AC)	25 mA / 10 VA (230 V AC)	25 mA / 18 VA (400 V AC)
<b>Measuring circuit</b>				
	<b>L1, L2, L3, N</b>		<b>L1, L2, L3</b>	
Monitoring functions	Phase failure	■	■	■
	Phase sequence	can be switched off	-	-
	Automatic phase sequence correction	-	-	-
	Over- / undervoltage	■	■	■
	Phase unbalance	■	■	■
	Interrupted neutral	■	-	-
Measuring range	Overvoltage	3x120-170 V AC	3x240-280 V AC	3x220-300 V AC
	Undervoltage	3x90-130 V AC	3x180-220 V AC	3x160-230 V AC
	Phase unbalance	2-25 % of average of phase voltages		
Thresholds	Overvoltage	adjustable within measuring range		
	Undervoltage	adjustable within measuring range		
	Phase unbalance (switch-off value)	adjustable within measuring range		
Hysteresis related to the threshold value	Over- / undervoltage	fixed 5 %		
	Phase unbalance	fixed 20 %		
Rated frequency of the measuring signal	50/60 Hz			
Frequency range of the measuring signal	45-65 Hz			
Maximum measuring cycle time	100 ms			
Accuracy within the rated control supply voltage tolerance	$\Delta U \leq 0.5\%$			
Accuracy within the temperature range	$\Delta U \leq 0.06\% / \text{°C}$			
Measuring method	True RMS			
<b>Timing circuit</b>				
Start-up delay $t_s$	fixed 200 ms			
Tripping delay $t_v$	ON- or OFF-delay 0; 0.1-30 s adjustable			
Accuracy within the rated control supply voltage tolerance	$\Delta t \leq 0.5\%$			
Accuracy within the temperature range	$\Delta t \leq 0.06\% / \text{°C}$			
Indication of operational states	Details see function description / -diagrams			
<b>Output circuits</b>				
	15-16/18, 25-26/28			
Kind of output	1x2 c/o contacts (Relays)			
Operating principle <sup>1)</sup>	closed-circuit principle			
Contact material	AgNi alloy, Cd free			
Rated operational voltage $U_o$ (IEC/EN 60947-1)	250 V			
Minimum switching power	24 V / 10 mA			
Maximum switching voltage	see load limit curve			
Rated operational current $I_o$ (IEC/EN 60947-5-1)	AC12 (resistive) 230 V	4 A		
	AC15 (inductive) 230 V	3 A		
	DC12 (resistive) 24 V	4 A		
	DC13 (inductive) 24 V	2 A		
AC rating (UL 508)	Utilization category (Control Circuit Rating Code)	B 300		
	max. rated operational voltage	300 V AC		
	max. continuous thermal current at B 300	5 A		
	max. making/breaking apparent power at B 300	3600/360 VA		
Mechanical lifetime	30 x 10 <sup>6</sup> switching cycles			
Electrical lifetime (AC12, 230 V, 4 A)	0.1 x 10 <sup>6</sup> switching cycles			
Max. fuse rating to achieve short-circuit protection	n/c contact	6 A fast-acting		
	n/o contact	10 A fast-acting		

<sup>1)</sup> Closed-circuit principle: Output relay(s) de-energize(s) if measured value exceeds or falls below the adjusted threshold value

# Three-phase monitoring relays

## Technical data

Data at  $T_a = 25\text{ °C}$  and rated values, unless otherwise indicated

Type		CM-MPS.11	CM-MPS.21	CM-MPS.31	CM-MPS.41
<b>General data <sup>2)</sup></b>					
MTBF		on request			
Duty time		100%			
Dimensions	product dimensions	22.5 x 85.6 x 103.7 mm (0.89 x 3.37 x 4.08 in)			
	packaging dimensions	97 x 109 x 30 mm (3.82 x 4.29 x 1.18 in)			
(W x H x D)					
Weight		<b>Screw connection technology</b>		<b>Easy Connect Technology (Push-in)</b>	
	net weight	depending on device, see ordering details			
	gross weight	depending on device, see ordering details			
Mounting		DIN rail (IEC/EN 60715), snap-on mounting without any tool			
Mounting position		any			
Minimum distance to other units	vertical / horizontal	not necessary / not necessary			
Material of housing		UL 94 V-0			
Degree of protection	housing / terminals	IP50 / IP20			
<b>Electrical connection <sup>2)</sup></b>					
Wire size		<b>Screw connection technology</b>		<b>Easy Connect Technology (Push-in)</b>	
	fine-strand with(out) wire end ferrule	1 x 0.5-2.5 mm <sup>2</sup> (1 x 20-14 AWG) 2 x 0.5-1.5 mm <sup>2</sup> (2 x 20-16 AWG)		2 x 0.5-1.5 mm <sup>2</sup> (2 x 20-16 AWG)	
		rigid	1 x 0.5-4 mm <sup>2</sup> (1 x 20-12 AWG) 2 x 0.5-2.5 mm <sup>2</sup> (2 x 20-14 AWG)		2 x 0.5-1.5 mm <sup>2</sup> (2 x 20-16 AWG)
Stripping length		8 mm (0.32 in)			
Tightening torque		0.6-0.8 Nm (5.31-7.08 lb.in)		-	
<b>Environmental data</b>					
Ambient temperature ranges	operation / storage	-25...+60 °C / -40...+85 °C			
Damp heat (IEC 60068-2-30)		55 °C, 6 cycles			
Climatic category		3K3			
Vibration (sinusoidal) (IEC/EN 60255-21-1)		Class 2			
Shock (IEC/EN 60255-21-2)		Class 2			
<b>Isolation data <sup>2)</sup></b>					
Rated insulation voltage $U_i$	input circuit / output circuit	600 V			
	output circuit 1 / output circuit 2	300 V			
Rated impulse withstand voltage $U_{imp}$ (VDE 0110, IEC/EN 60664)	input circuit	6 kV; 1.2/50 $\mu$ s			
	output circuit	4 kV; 1.2/50 $\mu$ s			
Test voltage between all isolated circuits (type test)		2.5 kV, 50 Hz, 1 s			
Basis isolation	input circuit / output circuit	600 V			
Protective separation (VDE 0106 part 101 and 101/A, IEC/EN 61140)	input circuit / output circuit	yes		-	
Pollution degree (VDE 0110, IEC/EN 60664)		3			
Overvoltage category (VDE 0110, IEC 60664)		III			
<b>Standards <sup>2)</sup></b>					
Product standard		IEC/EN 60255-6, EN 50178			
Low Voltage Directive		2006/95/EG			
EMC directive		2004/108/EG			
RoHS directive		2002/95/EG			
<b>Electromagnetic compatibility</b>					
Interference immunity to		EN 61000-6-1, EN 61000-6-2			
electrostatic discharge	IEC/EN 61000-4-2	Level 3 (6 kV / 8 kV)			
radiated, radio-frequency, electromagnetic field	IEC/EN 61000-4-3	Level 3 (10 V/m)			
electrical fast transient / burst	IEC/EN 61000-4-4	Level 3 (2 kV / 2 kHz)			
surge	IEC/EN 61000-4-5	Level 4 (2 kV L-L)			
conducted disturbances, induced by radio-frequency fields	IEC/EN 61000-4-6	Level 3 (10 V)			
harmonics and interharmonics	IEC/EN 61000-4-13	Class 3			
Interference emission		EN 61000-6-3, EN 61000-6-4			
high-frequency radiated	IEC/CISPR 22, EN 50022	Class B			
high-frequency conducted	IEC/CISPR 22, EN 50022	Class B			

<sup>2)</sup> Data for devices 1SVR 730 xxx xxx, 1SVR 740 xxx xxx, 1SVR 750 xxx xxx, 1SVR 760 xxx xxx. For devices 1SVR x30 xxx xxx, 1SVR x50 xxx xxx refer to the data sheet.



# Three-phase monitoring relays

## Technical data

Data at  $T_a = 25\text{ °C}$  and rated values, unless otherwise indicated

Type	CM-MPS.23	CM-MPS.43	CM-MPN.52	CM-MPN.62	CM-MPN.72
<b>Input circuit = Measuring circuit</b>	<b>L1, L2, L3, N</b>		<b>L1, L2, L3</b>		
Rated control supply voltage $U_s =$ measuring voltage	3x180-280 V AC	3x300-500 V AC	3x350-580 V AC	3x450-720 V AC	3x530-820 V AC
Rated control supply voltage $U_s$ tolerance	-15...+10 %				
Rated frequency	50/60/400 Hz		50/60 Hz		
Frequency range	45-440 Hz		45-65 Hz		
Typical current / power consumption	5 mA / 4 VA (230 V AC)	5 mA / 4 VA (400 V AC)	29 mA / 41 VA (480 V AC)	29 mA / 52 VA (600 V AC)	29 mA / 59 VA (690 V AC)
<b>Measuring circuit</b>	<b>L1, L2, L3, N</b>		<b>L1, L2, L3</b>		
Monitoring functions	Phase failure	■	■	■	■
	Phase sequence	can be switched off			
	Automatic phase sequence correction	configurable			
	Over- / undervoltage	■	■	■	■
	Phase unbalance	■	■	■	■
	Interrupted neutral	■	-	-	-
Measuring range	Overvoltage	3x240-280 V AC	3x420-500 V AC	3x480-580 V AC	3x600-720 V AC
	Undervoltage	3x180-220 V AC	3x300-380 V AC	3x350-460 V AC	3x450-570 V AC
	Phase unbalance	2-25 % of average of phase voltages			
Thresholds	Overvoltage	adjustable within measuring range			
	Undervoltage	adjustable within measuring range			
	Phase unbalance (switch-off value)	adjustable within measuring range			
Hysteresis related to the threshold value	Over- / undervoltage	fixed 5 %			
	Phase unbalance	fixed 20 %			
Rated frequency of the measuring signal	50/60/400 Hz		50/60 Hz		
Frequency range of the measuring signal	45-440 Hz		45-65 Hz		
Maximum measuring cycle time	100 ms				
Accuracy within the rated control supply voltage tolerance	$\Delta U \leq 0.5\%$				
Accuracy within the temperature range	$\Delta U \leq 0.06\% / \text{°C}$				
Measuring method	True RMS				
<b>Timing circuit</b>					
Start-up delay $t_s$ and $t_{s2}$	fixed 200 ms				
Start-up delay $t_{s1}$	fixed 250 ms				
Tripping delay $t_v$	ON- or OFF-delay 0; 0.1-30 s adjustable			ON-delay 0; 0.1-30 s adjustable	
Accuracy within the rated control supply voltage tolerance	$\Delta t \leq 0.5\%$				
Accuracy within the temperature range	$\Delta t \leq 0.06\% / \text{°C}$				
Indication of operational states	Details see function description / -diagrams				
<b>Output circuits</b>	<b>15-16/18, 25-26/28</b>				
Kind of output	2x1 or 1x2 c/o contacts configurable (Relays)				
Operating principle <sup>1)</sup>	closed-circuit principle				
Contact material	AgNi alloy, Cd free				
Rated operational voltage $U_s$	IEC/EN 60947-1 250 V				
Minimum switching power	24 V / 10 mA				
Maximum switching voltage	see load limit curve				
Rated operational current $I_s$ (IEC/EN 60947-5-1)	AC12 (resistive) 230 V	4 A			
	AC15 (inductive) 230 V	3 A			
	DC12 (resistive) 24 V	4 A			
	DC13 (inductive) 24 V	2 A			
AC rating (UL 508)	Utilization category (Control Circuit Rating Code)	B 300			
	max. rated operational voltage	300 V AC			
	max. continuous thermal current at B 300	5 A			
	max. making/breaking apparent power at B 300	3600/360 VA			
Mechanical lifetime	30 x 10 <sup>6</sup> switching cycles				
Electrical lifetime (AC12, 230 V, 4 A)	0.1 x 10 <sup>6</sup> switching cycles				
Max. fuse rating to achieve short-circuit protection	n/c contact	6 A fast-acting		10 A fast-acting	
	n/o contact	10 A fast-acting			

<sup>1)</sup> Closed-circuit principle: Output relay(s) de-energize(s) if measured value exceeds or falls below the adjusted threshold value

# Three-phase monitoring relays

## Technical data

Data at  $T_a = 25\text{ °C}$  and rated values, unless otherwise indicated

Type	CM-MPS.23	CM-MPS.43	CM-MPN.52	CM-MPN.62	CM-MPN.72
<b>General data <sup>2)</sup></b>					
MTBF	on request				
Duty time	100%				
Dimensions (W x H x D)	product dimensions	22.5 x 85.6 x 103.7 mm (0.89 x 3.37 x 4.08 in)			
	packaging dimensions	97 x 109 x 30 mm (3.82 x 4.29 x 1.18 in)			
Weight	depending on device, see ordering details				
Mounting	DIN rail (IEC/EN 60715), snap-on mounting without any tool				
Mounting position	any				
Minimum distance to other units	vertical / horizontal	not necessary / not necessary			
Material of housing	UL 94 V-0				
Degree of protection	housing / terminals	IP50 / IP20			
<b>Electrical connection <sup>2)</sup></b>					
Wire size	fine-strand with(out) wire end ferrule	<b>Screw connection technology</b>		<b>Easy Connect Technology (Push-in)</b>	
		1 x 0.5-2.5 mm <sup>2</sup> (1 x 20-14 AWG)		2 x 0.5-1.5 mm <sup>2</sup> (2 x 20-16 AWG)	
		2 x 0.5-1.5 mm <sup>2</sup> (2 x 20-16 AWG)		2 x 0.5-1.5 mm <sup>2</sup> (2 x 20-16 AWG)	
Stripping length	rigid	1 x 0.5-4 mm <sup>2</sup> (1 x 20-12 AWG)		2 x 0.5-1.5 mm <sup>2</sup> (2 x 20-16 AWG)	
		2 x 0.5-2.5 mm <sup>2</sup> (2 x 20-14 AWG)		8 mm (0.32 in)	
Tightening torque	0.6-0.8 Nm (5.31-7.08 lb.in)				
<b>Environmental data</b>					
Ambient temperature ranges	operation / storage	-25...+60 °C / -40...+85 °C			
Damp heat (IEC 60068-2-30)		55 °C, 6 cycles			
Climatic category		3K3			
Vibration (sinusoidal) (IEC/EN 60255-21-1)		Class 2			
Shock (IEC/EN 60255-21-2)		Class 2			
<b>Isolation data <sup>2)</sup></b>					
Rated insulation voltage $U_i$	input circuit / output circuit	600 V		1000 V	
	output circuit 1 / 2	300 V			
Rated impulse withstand voltage $U_{imp}$ (VDE 0110, IEC/EN 60664)	input circuit	6 kV; 1.2/50 $\mu$ s		8 kV; 1.2/50 $\mu$ s	
	output circuit	4 kV; 1.2/50 $\mu$ s			
Test voltage (type test) between	isolated output circuits	2.5 kV, 50 Hz, 1 s			
	input circuit and isolated output circuits	2.5 kV, 50 Hz, 1 s		4 kV, 50 Hz, 1 s	
Basis isolation	input circuit / output circuit	600 V		1000 V	
Protective separation (VDE 0106 part 101 and 101/A, IEC/EN 61140)	input circuit / output circuit	-			
Pollution degree (VDE 0110, IEC/EN 60664)		3			
Overvoltage category (VDE 0110, IEC 60664)		III			
<b>Standards <sup>2)</sup></b>					
Product standard	IEC/EN 60255-6, EN 50178				
Low Voltage Directive	2006/95/EG				
EMC directive	2004/108/EG				
RoHS directive	2002/95/EG				
<b>Electromagnetic compatibility</b>					
Interference immunity to		EN 61000-6-1, EN 61000-6-2			
electrostatic discharge	IEC/EN 61000-4-2	Level 3 (6 kV / 8 kV)			
radiated, radio-frequency, electromagnetic field	IEC/EN 61000-4-3	Level 3 (10 V/m)			
electrical fast transient / burst	IEC/EN 61000-4-4	Level 3 (2 kV / 2 kHz)			
surge	IEC/EN 61000-4-5	Level 4 (2 kV L-N)		Level 4 (2 kV L-L)	
conducted disturbances, induced by radio-frequency fields	IEC/EN 61000-4-6	Level 3 (10 V)			
harmonics and interharmonics	IEC/EN 61000-4-13	Class 3			
Interference emission		EN 61000-6-3, EN 61000-6-4			
high-frequency radiated	IEC/CISPR 22, EN 50022	Class B			
high-frequency conducted	IEC/CISPR 22, EN 50022	Class B			

<sup>2)</sup> Data for devices 1SVR 730 xxx xxx, 1SVR 740 xxx xxx, 1SVR 750 xxx xxx, 1SVR 760 xxx xxx. For devices 1SVR x30 xxx xxx, 1SVR x50 xxx xxx refer to the data sheet.

# Three-phase monitoring relays

## Technical data

Data at  $T_a = 25\text{ °C}$  and rated values, unless otherwise indicated

Type	CM-UFS.2	
Input circuit - Measuring circuit	L1, L2, L3	L-N
Rated control supply voltage $U_s$ = measuring voltage	3 x 400 V AC	3 x 230 V AC
Rated control supply voltage tolerance $U_s$	-20...+20 %	
Control supply voltage range	3 x 300-500 V AC	3 x 180-280 V AC
Rated frequency	50 Hz	
Frequency range	45-55 Hz	
Typical current / power consumption	23 mA / 16 VA	
Power failure buffering time	min. 20 ms	
Input circuit - measuring circuit	L1, L2, L3	L-N
Monitoring functions	Phase failure ■ Over-/ undervoltage ■ Over-/ underfrequency ■ 10 minutes average value –	
Measuring range	Voltage range 3 x 320-480 V AC Frequency range 45-55 Hz	3 x 184-276 V AC
Thresholds	Overvoltage fix, 120 % of $U_s$ Undervoltage fix, 80 % of $U_s$ Overfrequency 50,3 or 51 Hz, configurable Underfrequency 49,7 or 49 Hz, configurable 10 minutes average value –	
Hysteresis related to the threshold value	Over-/ undervoltage fix 5 % Over-/ underfrequency fix 20 mHz	
Rated frequency of the measuring signal	50 Hz	
Frequency range of the measuring signal	45-55 Hz	
Maximum measuring cycle time	50 ms	
Maximum reaction time (time between fault detection and change of switching status of the relay)	Over-/ undervoltage < 120 ms Over-/ underfrequency < 100 ms 10 minutes average value –	
Accuracy within the rated control supply voltage tolerance	$\Delta U \leq 0,5\%$	
Accuracy within the temperature range	$\Delta U \leq 0,06\% / \text{°C}$	
Measuring method	True RMS	
Timing circuit		
Start-up delay $t_{s1}$ prior to grid connection after a short interruption	fix, 1 s	
Restart delay $t_{s2}$	adjustable, 0 s; 0,1 – 30 s	
Accuracy within the rated control supply voltage tolerance	$\Delta t \leq 0,5\%$	
Accuracy within the temperature range	$\Delta t \leq 0,06\% / \text{°C}$	
Indication of operational states	1 yellow LED, 2 red LEDs Details see operation mode and function description/diagrams	
Output circuits	15-16/18, 25-26/28	
Kind of output	Relais, 1 x 2 changeover	
Operation principle <sup>1)</sup>	closed-circuit principle	
Contact material	AgNi alloy, Cd free	
Rated operational voltage $U_o$ (IEC/EN 60947-1)	250 V	
Minimum switching voltage / switching current	24 V / 10 mA	
Maximum switching voltage / switching current	see load limit curve	
Rated operational current $I_o$ (IEC/EN 60947-5-1)	AC12 (resistive) 230 V 4 A AC15 (inductive) 230 V 3 A DC12 (resistive) 24 V 4 A DC13 (inductive) 24 V 2 A	
Mechanical lifetime	30 x 10 <sup>6</sup> switching cycles	
Electrical lifetime (AC12, 230 V, 4 A)	0,1 x 10 <sup>6</sup> switching cycles	
Max. fuse rating to achieve short-circuit protection	n/c contact	6 A fast-acting
	n/o contact	10 A fast-acting

<sup>1)</sup> Closed-circuit principle: Output relay(s) de-energize(s) if measured value exceeds or falls below the adjusted threshold value

# Three-phase monitoring relays

## Technical data

Data at  $T_a = 25\text{ °C}$  and rated values, unless otherwise indicated

Type		CM-UFS.2
<b>General data</b>		
MTBF		on request
Duty time		100%
Dimensions (W x H x D)	product dimensions	22.5 x 78 x 100 mm (0.89 x 3.07 x 3.94 in)
Weight	gross weight	0.140 (0.31)
Mounting		DIN rail (IEC/EN 60715), snap-on mounting without any tool
Mounting position		any
Minimum distance to other units	vertical / horizontal	not necessary / not necessary
Degree of protection	housing / terminals	IP50 / IP20
<b>Electrical connection</b>		
Wire size	fine-strand with(out) wire end ferrule	2 x 0.75 - 2.5 mm <sup>2</sup> (2 x 18-14 AWG)
	rigid	2 x 0.5 - 4 mm <sup>2</sup> (2 x 20-12 AWG)
Stripping length		7 mm (0.28 in)
Tightening torque		0.6-0.8 Nm (5.31-7.08 lb.in)
<b>Environmental data</b>		
Ambient temperature range	operation / storage	-25...+60 °C / -40...+85 °C
Damp heat, cyclic (IEC/EN 60068-2-30)		2 x 12 h cycle, 55 °C, 95 % RH
Climatic category (IEC/EN 60721-3-1)		3K3
Vibration (sinusoidal) (IEC/EN 60255-21-1)		Class 2
Shock (IEC/EN 60255-21-2)		Class 2
<b>Isolation data</b>		
Rated impulse withstand voltage $U_i$	input circuit / output circuit	600 V
	output circuit 1 / 2	300 V
Rated impulse withstand voltage $U_{imp}$ (VDE 0110, IEC/EN 60664)	input circuit	6 kV; 1,2/50 $\mu$ s
	output circuit	4 kV; 1,2/50 $\mu$ s
Test voltage between all isolated circuits (type test)		2,5 kV, 50 Hz, 1 s
Basis isolation	input circuit / output circuit	600 V
Protective separation (VDE 0160 Part 101 and 101/A, IEC/EN 61140)	input circuit / output circuit	yes
Pollution degree (VDE 0110, IEC/EN 60664)		3
Overvoltage category (VDE 0110, IEC 60664)		III
<b>Standards</b>		
Product standard		Type-tested in accordance with the "Guideline for Connections to ENEL distribution network" Ed.2.1., January 2011
Further standards		EN 50178, EN 61727
Low Voltage Directive		2006/95/EG
EMV-Directive		2004/108/EG
RoHS-Directive		2002/95/EG
<b>Electromagnetic compatibility</b>		
Interference immunity to		IEC/EN 61000-6-1, IEC/EN 61000-6-2
electrostatic discharge	IEC/EN 61000-4-2	Level 3 (6 kV / 8 kV)
radiated, radio-frequency, electromagnetic field	IEC/EN 61000-4-3	Level 3 (10 V/m)
electrical fast transient / burst	IEC/EN 61000-4-4	Level 3 (2 kV / 2 kHz)
surge	IEC/EN 61000-4-5	Level 4 (2 kV L-L, L-N)
conducted disturbances, induced by radio-frequency fields	IEC/EN 61000-4-6	Level 3 (10 V)
harmonics and interharmonics	IEC/EN 61000-4-13	Class 3
Interference emission		IEC/EN 61000-6-3, IEC/EN 61000-6-4
high-frequency radiated	IEC/CISPR 22, EN 50022	Class B
high-frequency conducted	IEC/CISPR 22, EN 50022	Class B

# Insulation monitoring relays for unearthed supply systems

## Product group picture

2



# Insulation monitoring relays for unearthed supply systems

## Table of contents

<b>Insulation monitoring relays for unearthed supply systems</b>	
Product group picture	2/53
Table of contents	2/54
Benefits and advantages	2/55
Insulation monitoring in IT systems	2/56
Application / monitoring function, Measuring principle	2/57
Characteristics	2/58
Selection and conversion table	2/59
Ordering details	2/60
Operating state indication	2/61
Connection diagrams, DIP switches	2/62
Technical data	2/63
Technical data - New housing range	2/66
Technical data	2/67

# Insulation monitoring relays for unearthed supply systems

## Benefits and advantages

2



2CDC251 079 F0009



2CDC251 078 F0009



2CDC251 060 F0009

### Insulation monitoring relays for unearthed pure AC systems: Characteristics

- For monitoring the insulation resistance of unearthed IT systems: up to  $U_n = 400$  V AC
- According to IEC/EN 61227-8 "Electrical safety in low voltage distribution systems up to 1000 V AC and 1500 V DC – Equipment for testing, measuring or monitoring of protective measures – Part 8: Insulation monitoring devices for IT systems"
- Rated control supply voltage 24–240 V AC/DC
- Superimposed DC signal
- One measuring range 1–100 k $\Omega$
- Precise adjustment of the threshold value in 1 k $\Omega$  steps
- Interrupted wire detection
- Fault storage/latching configurable by control input
- 1 c/o contact, closed-circuit principle
- 22.5 mm [0.89 in] width
- 3 LEDs for status indication

### A new generation of insulation monitoring relays of the CM range consolidates ABB's strengths in innovative control products.

The new products are in accordance to IEC/EN 61557-1 and to IEC/EN 61557-8. That means the monitoring relays can be used directly to measure the insulation resistance in unearthed AC and DC mains with a voltage up to 690 V AC and 1000 V DC!

With the new prognostic measuring principle the measuring and response time is reduced significantly.

### Insulation monitoring relays for unearthed AC, DC or mixed AC/DC systems: Characteristics

- For monitoring the insulation resistance of unearthed IT systems up to  $U_n = 250$  V AC and 300 V DC or  $U_n = 400$  V AC and 600 V DC
- According to IEC/EN 61227-8 "Electrical safety in low voltage distribution systems up to 1000 V AC and 1500 V DC – Equipment for testing, measuring or monitoring of protective measures – Part 8: Insulation monitoring devices for IT systems"
- Rated control supply voltage 24–240 V AC/DC
- Prognostic measuring principle with superimposed square wave signal
- 1 or 2 measuring ranges (1–100k $\Omega$  or 1–100 k $\Omega$  + 2–200 k $\Omega$ )<sup>1)</sup>
- 1 or 2 (configurable) c/o contacts<sup>1)</sup>
- Precise adjustment of the measuring value in 1 or 2 k $\Omega$  steps<sup>1)</sup>
- (non-volatile) fault storage, configurable latching, interrupted wire protection, open- or closed-circuit principle selectable<sup>1)</sup>
- 22.5 or 45 mm width
- 3 LEDs for status indication
- Solution for solar available

<sup>1)</sup> depending on device

### Standardisation background:

- IEC/EN 61557-1 "Electrical safety in low voltage distribution system up to 1000 V AC and 1500 V DC – Equipment for testing, measuring or monitoring of protective measures – Part 1: General requirements"
- IEC/EN 61557-8 "Electrical safety in low voltage distribution system up to 1000 V AC and 1500 V DC – Equipment for testing, measuring or monitoring of protective measures – Part 1: Insulation monitoring devices for IT systems"

# Insulation monitoring relays for unearthed supply systems

## Insulation monitoring in IT systems

In electricity supply systems, an earthing system defines the electrical potential of the conductors relative to that of the earth's conductive surface. The choice of earthing system has implications for the safety and electromagnetic compatibility of the power supply. Note that regulations for earthing (grounding) systems vary considerably among different countries.

The international standard IEC 60364 distinguishes three families of earthing arrangements, using the two-letter codes TN, TT and IT.

### IT supply systems

The IT system is supplied either by an isolation transformer or a voltage source, such as battery or a generator.

In this system no active conductor is directly connected to earth potential. The advantage of this is that only a small fault current can flow in case of an insulation fault. This current is essentially caused by the leakage capacitance of the system.

The fuse of the system or MCB does not respond, thus maintaining the voltage supply and therefore operation even in case of a phase-to-earth fault.

The first letter indicates the connection between earth and the power-supply equipment (generator or transformer):

T: direct connection of a point with earth (Latin: terra)

I: no point is connected with earth (insulation), except perhaps via a high impedance

The second letter indicates the connection between earth and the electrical device being supplied:

T: direct connection of a point with earth

N: direct connection to neutral at the origin of installation, which is connected to the earth

The high reliability of an IT system is guaranteed thanks to continuous insulation monitoring.

The insulation monitoring device recognizes insulation faults as they develop, and immediately reports that the value has fallen below the minimum. This prevents operational interruptions caused by a second more severe insulation fault.

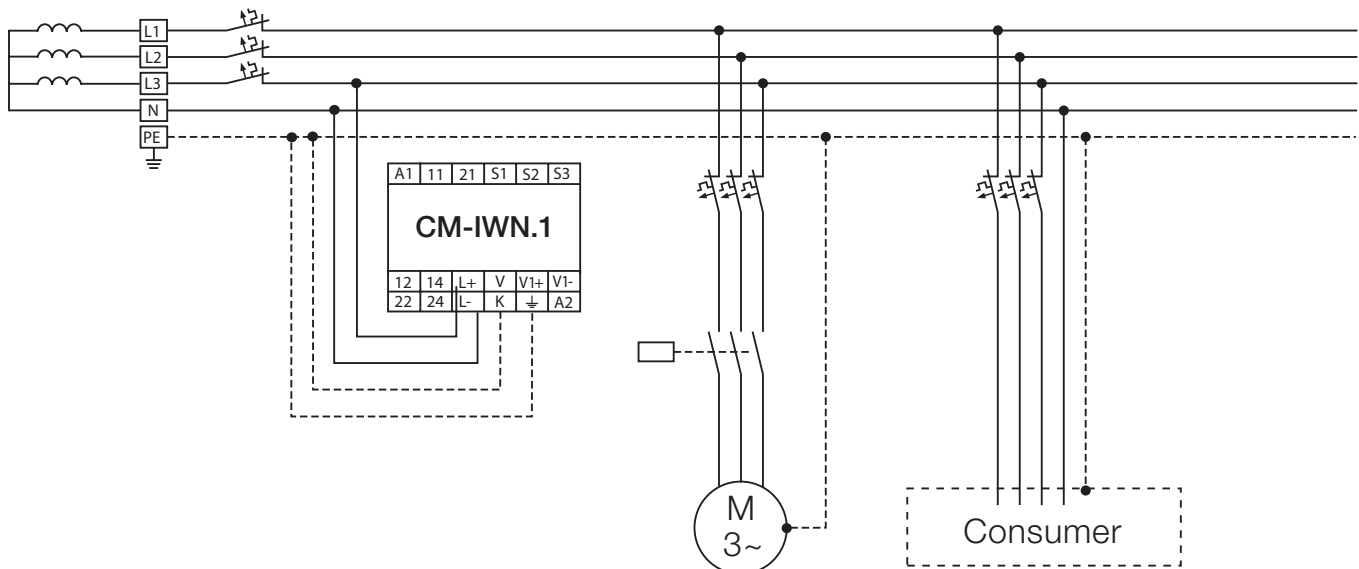



# Insulation monitoring relays for unearthed supply systems

## Application / monitoring function, Measuring principle

2

### Application / monitoring function CM-IWS.2

The CM-IWS.2 serves to monitor insulation resistance in accordance with IEC 61557-8 in unearthed IT AC systems. The insulation resistance between system lines and system earth is measured. If this falls below the adjustable threshold values, the output relay de-energizes. The device can monitor control circuits (single-phase) and main circuits (3-phase). Supply systems with voltages  $U_n = 0-400$  V AC (45-65 Hz) can be directly connected to the measuring inputs and their insulation resistance being monitored. For systems with voltages above 400 V AC the insulation monitoring relay CM-IWN.1 with or without the coupling unit CM-IVN can be used.

### Application / monitoring function CM-IWS.1

The CM-IWS.1 serves to monitor insulation resistance in accordance with IEC 61557-8 in unearthed IT AC systems, IT AC systems with galvanically connected DC circuits, or unearthed IT DC systems. The insulation resistance between system lines and system earth is measured. If this falls below the adjustable threshold value, the output relay de-energizes. The device can monitor control circuits (single-phase) and main circuits (3-phase). Supply systems with voltages  $U_n = 0-250$  V AC (15-400 Hz) or 0-300 V DC can be directly connected to the measuring inputs and their insulation resistance being monitored. For systems with voltages above 250 V AC and 300 V DC the insulation monitoring relay CM-IWN.x with or without the coupling unit CM-IVN can be used.

### Application / monitoring function CM-IWN.1 / CM-IWN.5

The CM-IWN.x serves to monitor insulation resistance in accordance with IEC 61557-8 in unearthed IT AC systems, IT AC systems with galvanically connected DC circuits, or unearthed IT DC systems. The insulation resistance between system lines and system earth is measured. If this falls below the adjustable threshold values, the output relays switch into the fault state. The device can monitor control circuits (single-phase) and main circuits (3-phase). Supply systems with voltages  $U_n = 0-400$  V AC (15-400 Hz) or 0-600 V DC can be directly connected to the measuring inputs and their insulation resistance being monitored. For systems with voltages above 400 V AC and 600 V DC the coupling unit CM-IVN can be used for the expansion of the CM-IWN.x voltage range.

### Application / monitoring function CM-IVN

The coupling unit CM-IVN is designed to extend the nominal voltage range of the insulation monitoring relay CM-IWN.1 up to 690 V AC and 1000 V DC. The coupling unit can be connected to the system to be monitored by means of the terminals VL+ and VL-. The terminal V $\perp$  has to be connected to the earth potential. The terminals L+, V1+, L-, V1-, VS and VE have to be connected to the CM-IWN.1 as shown in the connection diagrams below. Supply systems with voltages  $U_n = 0-690$  V AC (15-400 Hz) or 0-1000 V DC can be connected.

### Measuring principle CM-IWS.2

A superimposed DC measuring signal is used for measurement. From the superimposed DC measuring voltage and its resultant current the value of the insulation resistance of the system to be monitored is calculated.

### Measuring principle CM-IWS.1

A pulsating measuring signal is fed into the system to be monitored and the insulation resistance calculated. This pulsating measuring signal alters its form depending on the insulation resistance and system leakage capacitance. From this altered form the change in the insulation resistance is forecast. When the forecast insulation resistance corresponds to the insulation resistance calculated in the next measurement cycle and is smaller than the set threshold value, the output relay de-energizes. This measuring principle is also suitable for the detection of symmetrical insulation faults.

### Measuring principle CM-IWN.1 / CM-IWN.5

A pulsating measuring signal is fed into the system to be monitored and the insulation resistance calculated. This pulsating measuring signal alters its form depending on the insulation resistance and system leakage capacitance. From this altered form the change in the insulation resistance is forecast. When the forecast insulation resistance corresponds to the insulation resistance calculated in the next measurement cycle and is smaller than the set threshold value, the output relays are activated or deactivated, depending on the device configuration. This measuring principle is also suitable for the detection of symmetrical insulation faults.

### Measuring principle CM-IVN

With CM-IWN.1 a pulsating measuring signal is fed into the system to be monitored and the insulation resistance calculated. This pulsating measuring signal alters its form depending on the insulation resistance and system leakage capacitance. From this altered form the change in the insulation resistance is forecast. When the forecast insulation resistance corresponds to the insulation resistance calculated in the next measurement cycle and is smaller than the set threshold value, the output relays are activated or deactivated, depending on the device configuration. This measuring principle is also suitable for the detection of symmetrical insulation faults.

# Insulation monitoring relays for unearthed supply systems

## Characteristics

### Characteristics CM-IWS.2

- For monitoring the insulation resistance of unearthed IT systems up to  $U_n = 400$  V AC
- Rated control supply voltage 24-240 V AC/DC
- Measuring principle with superimposed DC voltage
- One measuring range 1-100 k $\Omega$
- Precise adjustment of the threshold value in 1 k $\Omega$  steps
- Fault storage / latching configurable by control input
- 1 c/o contact, closed-circuit principle
- 22.5 mm [0.89 in] width
- 3 LEDs for status indication

### Characteristics CM-IWS.1

- For monitoring the insulation resistance of unearthed IT systems up to  $U_n = 250$  V AC and 300 V DC
- Rated control supply voltage 24-240 V AC/DC
- Prognostic measuring principle with superimposed square wave signal
- One measuring range 1-100 k $\Omega$
- Precise adjustment of the threshold value in 1 k $\Omega$  steps
- Interrupted wire detection
- Fault storage / latching configurable by control input
- 1 c/o [SPDT] contact, closed-circuit principle
- 22.5 mm [0.89 in] width
- 3 LEDs for status indication

### Characteristics CM-IWN.1, CM-IWN.4, CM-IWN.5, CM-IWN.6

- For monitoring the insulation resistance of unearthed IT systems up to  $U_n = 400$  V AC and 600 V DC
- CM-IWN.4,5,6: According to IEC/EN 61557-8 "Electrical safety in low voltage distribution systems up to 1000 V a.c. and 1500 V d.c. – Equipment for testing, measuring or monitoring of protective measures – Part 8: Insulation monitoring devices for IT systems"
- Rated control supply voltage 24-240 V AC/DC
- Prognostic measuring principle with superimposed square wave signal
- Two measuring ranges 1-100 k $\Omega$  and 2-200 k $\Omega$
- One (1 x 2 c/o) or two (2 x 1 c/o) threshold values  $R_{an1}/R1^{1)}$  (final switch-off) and  $R_{an2}/R21)$  (prewarning) configurable<sup>2)</sup>
- Precise adjustment of the threshold values in 1 k $\Omega$  steps (R1) and 2 k $\Omega$  steps (R2)
- Interrupted wire detection configurable
- Non-volatile fault storage configurable
- Open- or closed-circuit principle configurable
- 45 mm (1.77 in) width
- 3 LEDs for status indication
- System leakage capacitance: 20  $\mu$ F, 500  $\mu$ F, 1000  $\mu$ F or 2000  $\mu$ F

<sup>1)</sup> term. acc. to IEC/EN 61557-8

<sup>2)</sup> R2 only active with 2 x 1 c/o configuration

### Characteristics CM-IVN

- Expansion of the nominal voltage range of the insulation monitoring relay CM-IWN.1 for monitoring the insulation resistance of unearthed IT systems up to 690 V AC and 1000 V DC
- According to IEC/EN 61557-8 "Electrical safety in low voltage distribution systems up to 1000 V AC and 1500 V DC – Equipment for testing, measuring or monitoring of protective measures – Part 8: Insulation monitoring devices for IT systems"
- Passive device, no supply voltage needed
- 45 mm [1.77 in] width

# Insulation monitoring relays for unearthed supply systems

## Selection and conversion table

Existing range		New range <sup>1)</sup>	
Type	Order number	Type	Order number
CM-IWS.2	1SVR 630 670 R0200	CM-IWS.2S	1SVR 730 670 R0200
CM-IWS.1	1SVR 630 660 R0100	CM-IWS.2P	1SVR 740 670 R0200
CM-IWN.1	1SVR 650 660 R0200	CM-IWS.1S	1SVR 730 660 R0100
		CM-IWS.1P	1SVR 740 660 R0100
		CM-IWN.1S	1SVR 750 660 R0200
		CM-IWN.1P	1SVR 760 660 R0200
		CM-IWN.4S	1SVR 750 660 R0300
		CM-IWN.4P	1SVR 760 660 R0300
		CM-IWN.5S	1SVR 750 660 R0400
		CM-IWN.5P	1SVR 760 660 R0400
		CM-IWN.6S	1SVR 750 660 R0500
		CM-IWN.6P	1SVR 760 660 R0500

**Rated control supply voltage U<sub>c</sub>**

24 - 240 VAC/DC	■	■	■	■	■	■	■	■	■	■	■	■
-----------------	---	---	---	---	---	---	---	---	---	---	---	---

**Measuring voltages**

250 V AC (L-PE)			■	■								
400 V AC (L-PE)	■	■			■	■	■	■	■	■	■	■
690 V AC (L-PE)					■ <sup>2)</sup>	■ <sup>2)</sup>	■ <sup>2)</sup>	■ <sup>2)</sup>	■ <sup>2)</sup>	■ <sup>2)</sup>	■ <sup>2)</sup>	■ <sup>2)</sup>
300 V DC (L-PE)			■	■								
600 V DC (L-PE)					■	■	■	■	■	■	■	■
1000 V DC (L-PE)					■ <sup>2)</sup>	■ <sup>2)</sup>	■ <sup>2)</sup>	■ <sup>2)</sup>	■ <sup>2)</sup>	■ <sup>2)</sup>	■ <sup>2)</sup>	■ <sup>2)</sup>

**Measuring range**

1 - 100 kΩ	■	■	■	■	■	■	■	■	■	■	■	■
2 - 200 kΩ					■	■	■	■	■	■	■	■

**System leakage capacitance, max.**

10 μF	■	■	■	■								
20 μF					■	■						
500 μF							■	■				
1000 μF									■	■		
2000 μF											■	■
1 c/o	■	■	■	■								
1 x 2 c/o or 2 x 1 c/o					■	■	■	■	■	■	■	■

**Working principle**

open circuit principle	■	■	■	■								
open or closed principle adjustable					■	■	■	■	■	■	■	■

**Test**

Front face button or control input	■	■	■	■	■	■	■	■	■	■	■	■
------------------------------------	---	---	---	---	---	---	---	---	---	---	---	---

**Reset**

Front face button or control input	■	■	■	■	■	■	■	■	■	■	■	■
Fault storage / latching configurable	■	■	■	■	■	■	■	■	■	■	■	■
Non voltage storage configurable	■	■	■	■	■	■	■	■	■	■	■	■
Interrupted wire detection					■	■	■	■	■	■	■	■
Threshold values configurable	1	1	1	1	2	2	2	2	2	2	2	2

<sup>2)</sup> With coupling module CM-IVN	Existing range <sup>3)</sup>				New range <sup>1)</sup>							
screw version	1SVR650669R9400				CM-IVN.S: 1SVR750669R9400							
push-in version					CM-IVN.P: 1SVR760669R9400							

<sup>1)</sup> available 4th quarter 2012

<sup>2)</sup> with coupling module CM-IVN

<sup>3)</sup> Existing range will be available until release of new generation

# Insulation monitoring relays for unearthed supply systems

## Ordering details



2CDC 251 079 S0009

CM-IWS.2

### Description

The high reliability of an IT system is guaranteed thanks to continuous insulation monitoring. An insulation monitoring device recognizes insulation faults as they develop, and immediately reports that the value has fallen below the minimum. This prevents operational interruption caused by a second, more severe insulation fault.

ABB developed a totally new range of insulation monitors for AC, DC or mixed AC/DC IT Systems up to 690 V AC or 1000 V DC. With only 4 devices most standard applications can be served. Additionally a version for solar applications with increased earth leakage capacitance has been added.



2CDC 251 078 S0009

CM-IWS.1



2CDC 251 080 S0009

CM-IWN.1



2CDC 251 081 S0009

CM-IVN

### Ordering details - Existing range

Rated control supply voltage = measuring voltage	Nominal voltage $U_n$ of the distribution system to be monitored	System leakage capacitance, max.	Adjustment range of the specified response value $R_{an}$ (threshold)	Type	Order code	Price 1 pce	Weight (1 pce) kg (lb)
24-240 V AC/DC	0-250 V AC / 0-300 V DC	10 $\mu$ F	1-100 k $\Omega$	CM-IWS.1	1SVR630660R0100		0.133 (0.293)
24-240 V AC/DC	0-400 V AC	10 $\mu$ F	1-100 k $\Omega$	CM-IWS.2	1SVR630670R0200		0.127 (0.280)
24-240 V AC/DC	0-400 V AC / 0-600 V DC	20 $\mu$ F	1-100 k $\Omega$ 2-200 k $\Omega$ (activated / de-activated by DIP-switch)	CM-IWN.1	1SVR650660R0200		0.231 (0.509)
24-240 V AC/DC	0-400 V AC / 0-600 V DC	1000 $\mu$ F		CM-IWN.5	1SVR650660R0400		0.231 (0.509)
Passive device, no control supply voltage needed	0-690 V AC / 0-1000 V DC			CM-IVN	1SVR650669R9400		0.169 (0.373)

### Ordering details - New range available at 4th quarter of 2012

Rated control supply voltage = measuring voltage	Nominal voltage $U_n$ of the distribution system to be monitored	System leakage capacitance, max.	Adjustment range of the specified response value $R_{an}$ (threshold)	Type	Order code	Price 1 pce	Weight (1 pce) kg (lb)
24-240 V AC/DC	0-250 V AC / 0-300 V DC	10 $\mu$ F	1-100 k $\Omega$	CM-IWS.1S	1SVR730660R0100		0.148 (0.326)
				CM-IWS.1P	1SVR740660R0100		0.137 (0.302)
24-240 V AC/DC	0-400 V AC	10 $\mu$ F	1-100 k $\Omega$	CM-IWS.2S	1SVR730670R0200		0.141 (0.311)
				CM-IWS.2P	1SVR740670R0200		0.130 (0.287)
24-240 V AC/DC	0-400 V AC / 0-600 V DC	20 $\mu$ F		CM-IWN.1S	1SVR750660R0200		0.241 (0.531)
				CM-IWN.1P	1SVR760660R0200		0.217 (0.478)
24-240 V AC/DC	0-400 V AC / 0-600 V DC	500 $\mu$ F	1-100 k $\Omega$ 2-200 k $\Omega$ (activated / de-activated by DIP-switch)	CM-IWN.4S	1SVR750660R0300		0.241 (0.531)
				CM-IWN.4P	1SVR760660R0300		0.217 (0.478)
24-240 V AC/DC	0-400 V AC / 0-600 V DC	1000 $\mu$ F		CM-IWN.5S	1SVR750660R0400		0.241 (0.531)
				CM-IWN.5P	1SVR760660R0400		0.217 (0.478)
24-240 V AC/DC	0-400 V AC / 0-600 V DC	2000 $\mu$ F		CM-IWN.6S	1SVR760660R0500		0.241 (0.531)
				CM-IWN.6P	1SVR760660R0500		0.217 (0.478)

# Insulation monitoring relays for unearthed supply systems

## Operating state indication

### LEDs, status information and fault messages CM-IWS.2

Operational state	LED U (green)	LED F (red)	LED R (yellow)
Start-up		OFF	OFF
No fault		OFF	
Insulation fault (below threshold value)			OFF
Invalid measuring result			OFF
Internal system fault	OFF		OFF
Test function		OFF	OFF
No fault after fault storage1)		2)	

1) The device has triggered after an insulation fault. The fault has been stored and the insulation resistance has returned to a higher value than the threshold value plus hysteresis.

2) Depending on the fault.

### LEDs, status information and fault messages CM-IWS.1

Operational state	LED U (green)	LED F (red)	LED R (yellow)
Start-up		OFF	OFF
No fault		OFF	
Insulation fault (below threshold value)			OFF
KE/⊥ wire interruption			OFF
System leakage capacitance too high / invalid measurement result			OFF
Internal system fault	OFF		OFF
Test function		OFF	OFF
No fault after fault storage1)		2)	

1) The device has triggered after an insulation fault. The fault has been stored and the insulation resistance has returned to a higher value than the threshold value plus hysteresis.

2) Depending on the fault.

### LEDs, status information and fault messages CM-IWN.1, CM-IWN.4, CM-IWN.5, CM-IWN.6

Operational state	LED U (green)	LED F (red)	LED R (yellow)
Start-up		OFF	OFF
No fault		OFF	1)
Prewarning			
Insulation fault (below threshold value)			1)
KE/⊥ wire interruption			1)
L+/L- wire interruption during system start-up / test function	/		1)
System leakage capacitance too high / invalid measurement result			1)
Internal system fault	1)		1)
Setting fault <sup>2)</sup>			
Test function		OFF	1)
No fault after fault storage <sup>3)</sup>		4)	

1) Depending on the configuration

2) Possible faulty setting: The threshold value for final switch-off is set at a higher value than the threshold value for prewarning.

3) The device has triggered after an insulation fault. The fault has been stored and the insulation resistance has returned to a higher value than the threshold value plus hysteresis.

4) Depending on the fault

# Insulation monitoring relays for unearthed supply systems

## Connection diagrams, DIP switches

Connection diagram CM-IWS.2

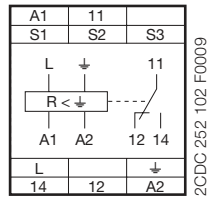

- A1-A2 Control supply voltage
- S1-S3 Remote test
- S2-S3 Remote reset
- L Measuring circuit/input, system connection
- ↓ Measuring circuit/input, earth connections
- 11-12/14 Output relay, closed-circuit principle

Connection diagram CM-IWS.1

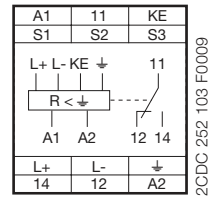

- A1-A2 Control supply voltage
- S1-S3 Remote test
- S2-S3 Remote reset
- L+, L- Measuring circuit/input, system connection
- ↓, KE Measuring circuit/input, earth connections
- 11-12/14 Output relay, closed-circuit principle

Connection diagram CM-IWN.1, 4, 5, 6

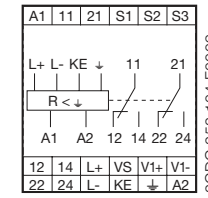

- A1-A2 Control supply voltage
- S1-S3 Remote test
- S2-S3 Remote reset
- L+, L- Measuring circuit/input, system connection
- ↓, KE Measuring circuit/input, earth connections
- VS, V1+, V1- Measuring circuit/input, earth connections
- 11-12/14 Connections for the coupling unit (if used)
- 21-22/24 Output relay 1, open- or closed-circuit principle
- Output relay 2, open- or closed-circuit principle

### DIP switches of CM-IWN.1, 4, 5, 6

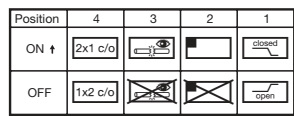

2CDC 252 050 F0b09

	ON	OFF (default)
<b>DIP switch 1</b>	Closed-circuit principle <input checked="" type="checkbox"/>	Open-circuit principle <input type="checkbox"/>
Operating principle of the output relays	If closed-circuit principle is selected, the output relays de-energize in case a fault is occurring. In non-fault state the relays are energized.	If open-circuit principle is selected, the output relays energize in case a fault is occurring. In non-fault state the relays are de-energized.
<b>DIP switch 2</b>	Fault storage activated (latching) <input type="checkbox"/>	Fault storage de-activated (non latching) <input checked="" type="checkbox"/>
Non-volatile fault storage	If the fault storage function is activated, the output relays remain in tripped position until a reset is done either by the front-face button or by the remote reset connection S2-S3. This function is non-volatile.	If the fault storage function is de-activated, the output relays switch back to their original position as soon as the insulation fault no longer exists.
<b>DIP switch 3</b>	Interrupted wire detection activated <input checked="" type="checkbox"/>	Interrupted wire detection de-activated <input type="checkbox"/> With this configuration the interrupted wire detection is de-activated.
Interrupted wire detection	With this configuration, the CM-IWN.1 monitoring relays the wires connected to + and KE for interruptions.	
<b>DIP switch 4</b>	2 x 1 c/o (SPDT) contact <input checked="" type="checkbox"/>	1 x 2 c/o (SPDT) contacts <input type="checkbox"/>
2 x 1 c/o, 1 x 2 c/o	If operating principle 2 x 1 c/o contact is selected, the output relay R1 (11-12/14) reacts to threshold value R1 (final switch-off) and the output relay R2 (21-22/24) reacts to threshold value R2 (prewarning)	If operating principle 1 x 2 c/o contacts is selected, both output relays R1 (11-12/14) and R2 (21-22/24) react synchronously to threshold value R1. Settings of the threshold value R2 have no effect on the operation.

### Connection diagram CM-IVN

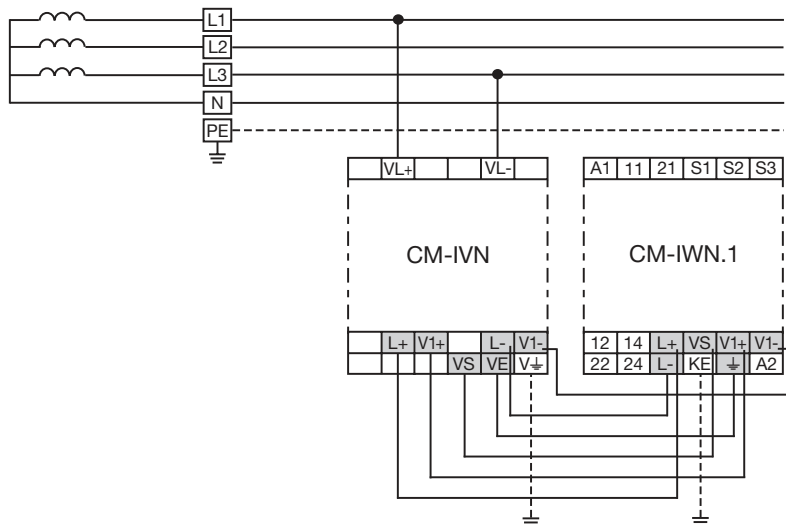

2CDC 252 107 F0009

- VE Connection to CM-IWN.1 - ↓
- VS Connection to CM-IWN.1 - VS
- L+ Connection to CM-IWN.1 - L+
- V1+ Connection to CM-IWN.1 - V1+
- L- Connection to CM-IWN.1 - L-
- V1- Connection to CM-IWN.1 - V1-
- VL+, VL- Measuring circuit / Measuring input Connection to the system
- V↓ Measuring circuit / Measuring input Connection to earth

# Insulation monitoring relays for unearthed supply systems

## Technical data

Data at  $T_a = 25\text{ °C}$  and rated values, unless otherwise indicated

		CM-IWS.2	CM-IWS.1	CM-IWN.1, 4, 5, 6
<b>Input circuit - Supply circuit</b>		<b>A1 - A2</b>		
Rated control supply voltage $U_s$		24-240 V AC/DC		
Rated control supply voltage tolerance		-15...+10 %		
Typical current / power consumption	24 V DC	30 mA / 0.7 VA	35 mA / 0.9 VA	55 mA / 1.3 VA
	115 V AC	12 mA / 1.4 VA	17 mA / 2.0 VA	20 mA / 2.3 VA
	230 V AC	12 mA / 2.8 VA	14 mA / 3.2 VA	15 mA / 3.5 VA
Rated frequency $f_N$		DC or 15-400 Hz		
Frequency range AC		13.5-440 Hz		
Power failure buffering time	min.	20 ms		
<b>Input circuit - Measuring circuit</b>		<b>L, ↓</b>	<b>L+, L-, ↓, KE</b>	<b>L+, L-, ↓, KE</b>
Monitoring function		insulation resistance monitoring of IT systems (IEC/EN 61557-8)		
Measuring principle		superimposed DC voltage	prognostic measuring principle with superimposed square wave signal	
Nominal voltage $U_n$ of the distribution system to be monitored		0-400 V AC	0-250 V AC / 0-300 V DC	400 V AC / 0-600 V DC
Voltage range of the distribution system to be monitored		0-460 V AC (tolerance +15 %)	0-287.5 V AC / 0-345 V DC (tolerance +15 %)	0-460 V AC / 0-690 V DC (tolerance +15 %)
Rated frequency $f_N$ of the distribution system to be monitored		50-60 Hz	DC or 15-400 Hz	DC or 15-400 Hz
System leakage capacitance $C_e$	max.	10 $\mu$ F		CM-IWN.1 20 $\mu$ F CM-IWN.5 1000 $\mu$ F
Tolerance of the rated frequency $f_N$		45-65 Hz	13.5-440 Hz	13.5-440 Hz
Extraneous DC voltage $U_b$ (when connected to an AC system)	max.	none	290 V DC	460 V DC
Number of possible response / threshold values		1		2
Adjustment range of the specified response value $R_{an}$ (threshold)	min.-max.	1-100 k $\Omega$		-
	min.-max. R1	-		1-100 k $\Omega$
	min.-max. R2	-		2-200 k $\Omega$ (activated / de-activated by DIP-switch)
Adjustment resolution		1 k $\Omega$		-
	R1	1 k $\Omega$		1 k $\Omega$
	R2	-		2 k $\Omega$
Tolerance of the adjusted threshold value / Relative percentage uncertainty A at -5...+45 °C, $U_n = 0-115\%$ , $U_s = 85-110\%$ , $f_N, f_s, C_e = 1\mu$ F	at 1-10 k $\Omega$ $R_F$	$\pm 0.5\%$		-
	at 10-100 k $\Omega$ $R_F$	$\pm 6\%$		-
	at 1-15 k $\Omega$ $R_F$	-		$\pm 1\text{ k}\Omega^*$
	at 15-200 k $\Omega$ $R_F$	-		$\pm 8\%$
Hysteresis related to the threshold value		25 %; min. 2 k $\Omega$		-
Internal impedance Z	at 50 Hz	135 k $\Omega$	100 k $\Omega$	155 k $\Omega$
Internal DC resistance $R_i$		185 k $\Omega$	115 k $\Omega$	185 k $\Omega$
Measuring voltage $U_m$		15 V	22 V	24 V
Tolerance of measuring voltage $U_m$		+10 %		-
Measuring current $I_m$	max.	0.1 mA	0.3 mA	0.15 mA
Response time $t_{an}$	pure AC system $0.5 \times R_{an}$ and $C_e = 1\mu$ F	max. 10 s		-
	DC system or AC system with connected rectifiers	-	max. 15 s	-
Repeat accuracy (constant parameters)		< 0.1 % of full scale		
Accuracy of $R_s$ (measured value) within the rated control supply voltage tolerance		< 0.05 % of full scale		
Accuracy of $R_s$ (measured value) within the operation temperature range	at 1-10 k $\Omega$ $R_F$	5 W / K		-
	at 10-100 k $\Omega$ $R_F$	0.05 % / K		-
	at 10-200 k $\Omega$ $R_F$	-		0.05 % / K
Transient over voltage protection ( $\perp$ - terminal)		Z-diode	avalanche diode	
<b>Input circuit - Control circuits</b>		<b>S1 - S2 - S3</b>		
Control inputs - volt free	S1-S3 S2-S3	remote test remote reset		
Maximum switching current in the control circuit		1 mA		
Maximum cable length to the control inputs		50 m - 100 pF/m [164 ft - 30.5 pF/ft]		
Minimum control pulse length		150 ms		
No-load voltage at the control input		$\leq 24\text{ V} \pm 5\%$	$\leq 24\text{ V DC}$	
<b>Indication of operational states</b>				
Control supply voltage		LED U (green)*		
Fault message		LED F (red)*		
Relay status		LED R (yellow)*		
<b>Output circuits</b>				

\*in combination with CM-IWN  $\pm 1.5\text{ k}\Omega$

# Insulation monitoring relays for unearthed supply systems

## Technical data

2

	CM-IWS.2	CM-IWS.1	CM-IWN.1, 4, 5, 6
Kind of output	relay, 1 c/o (SPDT) contact		2 x 1 or 1 x 2 c/o (SPDT) contacts configurable
Operating principle	closed-circuit principle <sup>1)</sup>		open- or closed circuit principle <sup>1)</sup> configurable
Contact material	AgNi alloy, Cd free		
Rated voltage (VDE 0110, IEC 60947-1)	250 V AC / 300 V DC		
Min. switching voltage / Min. switching current	24 V / 10 mA		
Max. switching voltage / Max. switching current	see data sheet		
Rated operational current I <sub>o</sub> (IEC/EN 60947-5-1)	AC12 (resistive) at 230 V	4 A	
	AC15 (inductive) at 230 V	3 A	
	DC12 (resistive) at 24 V	4 A	
	DC13 (inductive) at 24 V	2 A	
AC rating (UL 508)	Utilization category (Control Circuit Rating Code)	B 300, pilot duty general purpose (250 V, 4 A, cos φ 0.75)	
	max. rated operational voltage	250 V AC	
	max. continuous thermal current at B 300	4 A	
	max. making/breaking apparent power at B 300	3600/360 VA	
Mechanical lifetime	30 x 10 <sup>6</sup> switching cycles		
Electrical lifetime (AC12, 230 V, 4 A)	0.1 x 10 <sup>6</sup> switching cycles		
Max. fuse rating to achieve short-circuit protection	n/c contact	6 A fast-acting	
	n/o contact	10 A fast-acting	
Conventional thermal current I <sub>th</sub> (IEC/EN 60947-1)	4 A		
<b>General data <sup>1)</sup></b>			
Duty time	100 %		
Dimensions (W x H x D)	22.5 x 78 x 100 mm [0.89 x 3.07 x 3.94 in]		45 x 78 x 100 mm [1.78 x 3.07 x 3.94 in]
Weight	gross weight	0.149 kg [0.328 lb]	0.163 kg [0.359 lb]
	net weight	0.127 kg [0.280 lb]	0.133 kg [0.293 lb]
Mounting	DIN rail (EN 60715), snap-on mounting without any tool		
Mounting position	any		
Minimum distance to other units	vertical	not necessary	
	horizontal	10 mm [0.4 in] at U <sub>n</sub> > 240 V	not necessary
Degree of protection	housing / terminal	IP50 / IP20	
<b>Electrical connection <sup>1)</sup></b>			
Wire size	fine-strand with(out) wire end ferrule	2 x 0.75-2.5 mm <sup>2</sup> (2 x 18-14 AWG)	
	rigid	2 x 0.5-4 mm <sup>2</sup> (2 x 20-12 AWG)	
Stripping length	7 mm [0.28 in]		
Tightening torque	0.6-0.8 Nm [5.31-7.08 lb.in]		
<b>Environmental data <sup>1)</sup></b>			
Ambient temperature ranges	operation / storage / transport	-25...+60 °C/-40...+85 °C/-40...+85 °C	
Climatic category	IEC/EN 60721-3-3	3K5 (no condensation, no ice formation)	
Damp heat, cyclic	IEC/EN 60068-2-30	6 x 24 h cycle, 55 °C, 95 % RH	
Vibration, sinusoidal	IEC/EN 60255-21-1	Class 2	
Shock, half-sine	IEC/EN 60255-21-2	Class 2	
<b>Isolation data</b>			

<sup>1)</sup> The products with new order codes (1SVR 7x0 xxx xxx) vary in different technical data. Please refer to page: 2/66



# Insulation monitoring relays for unearthed supply systems

## Technical data

2

		CM-IWS.2	CM-IWS.1	CM-IWN.1, 4, 5, 6
Rated impulse withstand voltage $U_{imp}$ between all isolated circuits (IEC/EN 60947-1, IEC/EN 60664-1, VDE 0110-1)	supply / measuring circuit	6 kV		
	supply / output circuit	6 kV		
	measuring / output circuit	6 kV		
	output 1 / output circuit 2			4 kV
Pollution degree (IEC/EN 60664-1, VDE 0110-1)		3		
Overvoltage category (IEC/EN 60664-1, VDE 0110-1)		III		
Rated insulation voltage $U$ (IEC/EN 60947-1, IEC/EN 60664-1, VDE 0110-1)	supply / measuring circuit	400 V	300 V	600 V
	supply / output circuit	300 V		
	supply / measuring circuit	400 V	300 V	600 V
	output 1 / output circuit 2	-	-	300 V
Basis isolation for rated control supply voltage (IEC/EN 60664-1, VDE 0110-1)	supply / measuring circuit	400 V AC / 300 V DC	250 V AC / 300 V DC	400 V AC / 600 V DC
	supply / output circuit	250 V AC / 300 V DC		
	measuring / output circuit	400 V AC / 300 V DC	250 V AC / 300 V DC	400 V AC / 600 V DC
	output 1 / output 2	250 V AC / 300 V DC		
Protective separation (IEC/EN 61140)	supply / output circuit	250 V AC / 250 V DC		
	supply / measuring circuit	250 V AC / 250 V DC		
	measuring / output circuit	250 V AC / 250 V DC		
	supply / output circuit	2.32 kV, 50 Hz, 2 s		
Test voltage between all isolated circuits, routine test (IEC/EN 60255-5, IEC/EN 61010-1)	supply / measuring circuit	2.32 kV, 50 Hz, 2 s		
	supply / output circuit	2.32 kV, 50 Hz, 2 s		
	measuring / output circuit	2.2 kV, 50 Hz, 1 s		2.53 kV, 50 Hz, 1 s
<b>Standards</b>				
Product standard		IEC/EN 61557-8, IEC/EN 60255-6		
Other standards		EN 50178		
Low Voltage Directive		2006/95/EC		
EMC Directive		2004/108/EC		
RoHS Directive		2002/95/EC		
<b>Electromagnetic compatibility</b>				
Interference immunity to		IEC/EN 61000-6-1, IEC/EN 61000-6-2, IEC/EN 61326-2-4		
electrostatic discharge	IEC/EN 61000-4-2	Level 3, 6 kV / 8 kV		
radiated, radio-frequency, electromagnetic field	IEC/EN 61000-4-3	Level 3, 10 V/m (1 GHz) / 3 V/m (2 GHz) / 1 V/m (2.7 GHz)		
electrical fast transient/burst	IEC/EN 61000-4-4	Level 3, 2 kV / 5 kHz		
surge	IEC/EN 61000-4-5	Level 3, installation class 3, supply circuit and measuring circuit 1 kV L-L, 2 kV L-earth		
conducted disturbances, induced by radio-frequency fields	IEC/EN 61000-4-6	Level 3, 10 V		
voltage dips, short interruptions and voltage variations	IEC/EN 61000-4-11	Level 3		
harmonics and interharmonics	IEC/EN 61000-4-13	Level 3		
high-frequency radiated	IEC/CISPR 22, EN 50022	IEC/EN 61000-6-3, IEC/EN 61000-6-4 Class B		
high-frequency conducted	IEC/CISPR 22, EN 50022	Class B		

# Insulation monitoring relays for unearthed supply systems

## Technical data - New housing range

2

General data		CM-IWS.1, 2 S/P	CM-IWN.1, 4, 5, 6 S/P
Dimensions (W x H x D)	product dimensions	22.5 x 85.6 x 103.7 mm (0.89 x 3.37 x 4.08 in)	22.5 x 85.6 x 103.7 mm (0.89 x 3.37 x 4.08 in)
	packaging dimensions	97 x 109 x 30 mm (3.82 x 4.29 x 1.18 in)	97 x 109 x 30 mm (3.82 x 4.29 x 1.18 in)
Weight	CM-IWS.1P	0.137 (0.302)	
	CM-IWS.1S	0.148 (0.326)	
	CM-IWS.2P	0.130 (0.287)	
	CM-IWS.2S	0.141 (0.311)	
	CM-IWN.1S		0.241 (0.531)
	CM-IWN.1P		0.217 (0.478)
	CM-IWN.4S		0.241 (0.531)
	CM-IWN.4P		0.217 (0.478)
	CM-IWN.5S		0.241 (0.531)
	CM-IWN.5P		0.217 (0.478)
CM-IWN.6S		0.241 (0.531)	
CM-IWN.6P		0.217 (0.478)	
Mounting		DIN rail (IEC/EN 60715), snap-on mounting without any tool	
Mounting position		any	
Minimum distance to other units	vertical / horizontal	not necessary / not necessary	
Material of housing		UL 94 V-0	
Degree of protection	housing / terminals	IP50 / IP20	

Electrical connection		CM-IWS.1, CM-IWS.2, CM-IWN.1, 4, 5, 6 in new housing	
		Screw connection technology	Easy Connect Technology (Push-in)
Wire size	fine-strand with(out) wire end ferrule	1 x 0.5-2.5 mm <sup>2</sup> (1 x 20-14 AWG) 2 x 0.5-1.5 mm <sup>2</sup> (2 x 20-16 AWG)	2 x 0.5-1.5 mm <sup>2</sup> (2 x 20-16 AWG)
	rigid	1 x 0.5-4 mm <sup>2</sup> (1 x 20-12 AWG) 2 x 0.5-2.5 mm <sup>2</sup> (2 x 20-14 AWG)	2 x 0.5-1.5 mm <sup>2</sup> (2 x 20-16 AWG)
Stripping length		8 mm (0.32 in)	-
Tightening torque		0.6-0.8 Nm (5.31-7.08 lb.in)	-

# Insulation monitoring relays for unearthed supply systems

## Technical data

### Technical data - CM-IWN

Input circuit - Measuring circuit		VL+, VL-, V+
Function		expansion of the nominal voltage range of the insulation monitoring relay CM-IWN.1 to 690 V AC or 1000 V DC, max. length of connection cable 40 cm see CM-IWN.1
Measuring principle		see CM-IWN.1
Nominal voltage $U_n$ of the distribution system to be monitored		0-690 V AC / 0-1000 V DC
Voltage range of the distribution system to be monitored		0-793.5 V AC / 0-1150 V DC (tolerance +15 %)
Rated frequency $f_N$ of the distribution system to be monitored		DC or 15-400 Hz
Tolerance of the rated frequency $f_N$		13.5-440 Hz
System leakage capacitance $C_s$	max.	identical to that of the insulation monitoring relay used
Extraneous DC voltage $U_{dc}$ (when connected to an AC system)	max.	793.5 V DC
Tolerance of the adjusted threshold value / Relative percentage uncertainty A at -5...+45 °C, $U_n = 0-115$ %, $U_s = 85-110$ %, $f_s f_c = 1 \mu F$	at 1-15 k $\Omega$ $R_F$	$\pm 1.5$ k $\Omega$
	at 15-200 k $\Omega$ $R_F$	$\pm 8$ %
Internal impedance $Z_i$	at 50 Hz	195 k $\Omega$
Internal DC resistance $R_i$		200 k $\Omega$
Measuring voltage $U_m$		24 V
Tolerance of measuring voltage $U_m$		+10 %
Measuring current $I_m$		0.15 mA
<b>General data</b>		
MTBF		on request
Duty time		100 %
Dimensions (W x H x D)		45 x 78 x 100 mm [1.78 x 3.07 x 3.94 in]
Weight	gross weight	0.200 kg [0.441 lb]
	net weight	0.169 kg [0.373 lb]
Mounting		DIN rail (IEC/EN 60715), snap-on mounting without any tool
Mounting position		any
Minimum distance to other units	vertical	not necessary
	horizontal	10 mm [0.4 in] at $U_n > 600$ V
Degree of protection		IP50 / IP20
<b>Electrical connection</b>		
Wire size	fine-strand with(out) wire end ferrule	2 x 0.75-2.5 mm <sup>2</sup> (2 x 18-14 AWG)
	rigid	2 x 0.5-4 mm <sup>2</sup> (2 x 20-12 AWG)
Stripping length		7 mm [0.28 in]
Tightening torque		0.6-0.8 Nm [5.31-7.08 lb.in]
Max. length of connection cable to CM-IWN.1		40 cm
<b>Environmental data</b>		
Ambient temperature ranges	operation / storage / transport	-25...+60 °C / -40...+85 °C / -40...+85 °C
Climatic category	IEC/EN 60721-3-3	3K5 (no condensation, no ice formation)
Damp heat, cyclic	IEC/EN 60068-2-30	6 x 24 h cycle, 55 °C, 95 % RH
Vibration, sinusoidal	IEC/EN 60255-21-1	Class 2
Shock, half-sine	IEC/EN 60255-21-2	Class 2
<b>Isolation data</b>		
Rated impulse withstand voltage $U_{imp}$ between all isolated circuits (IEC/EN 60947-1, IEC/EN 60664-1, VDE 0110-1)	input circuit / PE	8 kV
Pollution degree (IEC/EN 60664-1, VDE 0110-1)		3
Overvoltage category (IEC/EN 60664-1, VDE 0110-1)		III
Rated insulation voltage $U_i$ (IEC/EN 60947-1, IEC/EN 60664-1, VDE 0110-1)	input circuit / PE	1000 V
Test voltage between all isolated circuits, routine test (IEC/EN 60255-5, IEC/EN 61010-1)	input circuit / PE	3.3 kV, 50 Hz, 1 s
<b>Standards</b>		
Product standard		IEC/EN 61557-8, IEC/EN 60255-6
Other standards		EN 50178
Low Voltage Directive		2006/95/EC
EMC Directive		2004/108/EC
RoHS Directive		2002/95/EC
<b>Electromagnetic compatibility</b>		
Interference immunity to electrostatic discharge	IEC/EN 61000-4-2	IEC/EN 61000-6-1, IEC/EN 61000-6-2, IEC/EN 61326-2-4 Level 3, 6 kV / 8 kV
	IEC/EN 61000-4-3	Level 3, 10 V/m (1 GHz) / 3 V/m (2 GHz) / 1 V/m (2.7 GHz)
radiated, radio-frequency, electromagnetic field	IEC/EN 61000-4-4	Level 3, 2 kV / 5 kHz
	IEC/EN 61000-4-5	Level 3, installation class 3, supply circuit and measuring circuit 1 kV L-L, 2 kV L-earth
electrical fast transient/burst surge	IEC/EN 61000-4-6	Level 3, 10 V
	IEC/EN 61000-4-11	Level 3
conducted disturbances, induced by radio-frequency fields	IEC/EN 61000-4-13	Level 3
	IEC/EN 61000-4-11	Level 3
voltage dips, short interruptions and voltage variations	IEC/EN 61000-4-13	Level 3
	IEC/EN 61000-4-11	Level 3
harmonics and interharmonics	IEC/EN 61000-4-13	Level 3
	IEC/EN 61000-4-11	Level 3
<b>Interference emission</b>		
high-frequency radiated	IEC/CISPR 22, EN 50022	IEC/EN 61000-6-3, IEC/EN 61000-6-4 Class B
	IEC/CISPR 22, EN 50022	Class B
high-frequency conducted	IEC/CISPR 22, EN 50022	Class B

# Insulation monitoring relays for unearthed supply systems

## Notes

A series of horizontal dotted lines intended for user notes.

# Motor load monitoring relays

## Product picture

2



# Motor load monitoring relays

## Table of contents

---

<b>Motor load monitoring relays</b>	
Product picture	2/69
Table of contents	2/70
Fields of application	2/71
Ordering details	2/72
Technical information	2/73
Technical data	2/74

# Motor load monitoring relays

## Fields of application

The motor load monitor relay monitors the load states of single-phase and three-phase asynchronous motors. The evaluation of the phase angle between current and voltage allows a very precise monitoring of the load states.

Compared with other conventional measuring principles (e.g. pressure transducers, current measurement),  $\cos \varphi$  monitoring is a more precise and economical alternative. The motor is used as a sensor for its own load status.

### 2 Main applications

- Pump monitoring
  - Dry-running protection (underload)
  - Closed valves (overload)
  - Pipe break (overload)
- Heating, air-conditioning, ventilation
  - Monitoring of filter pollution
  - V-belt breakage (underload)
  - Closed shutters/valves (overload)
  - Air ventilating volume
- Agitating machines
  - High consistency within the tank (overload)
  - Pollution of the tank (overload)
- Transport/Conveyance
  - Congested conveyor belts (overload)
  - Jamming of belts (overload)
  - Material accumulation in spiral conveyors (overload)
  - Lifting platforms
- Machine installation
  - Wear of tools, e.g. worn saw blades in circular saws, etc. (overload)
  - Tool breakage (underload)
  - V-belt drives (breakage underload)

### Pump control

#### Dry-running protection

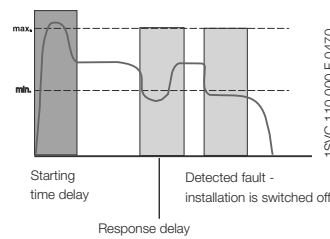

#### Filter pollution

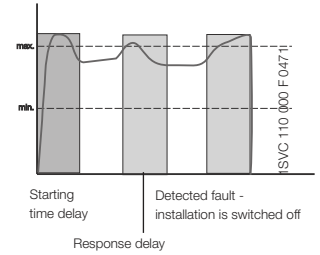

### Ventilator monitoring

#### V-belt monitoring

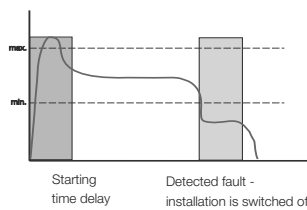

#### Filter pollution

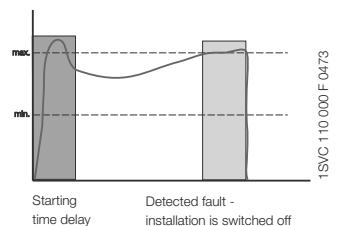

### Wiring examples (for motor currents $\leq 20$ A)

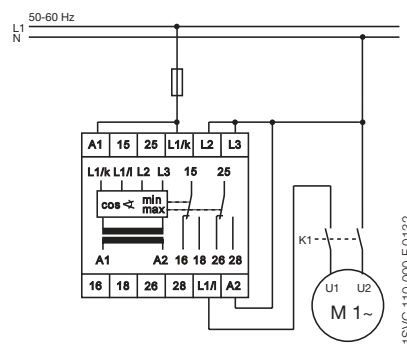
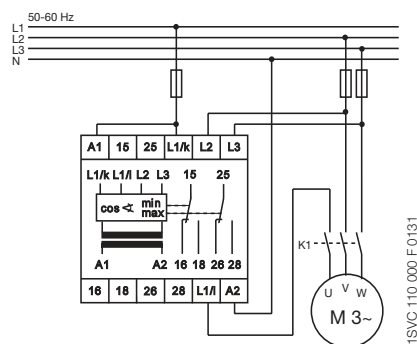

### Wiring examples (for motor currents $\geq 20$ A)

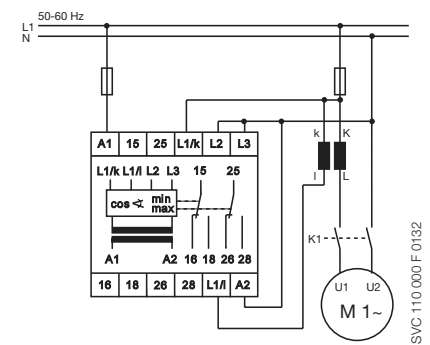
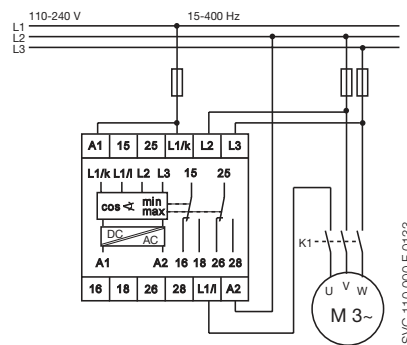
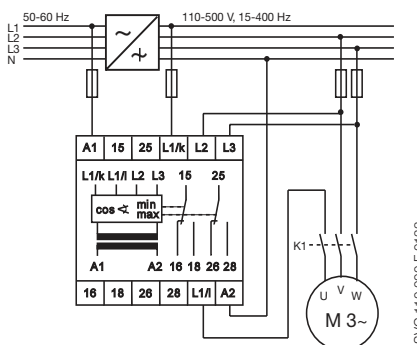
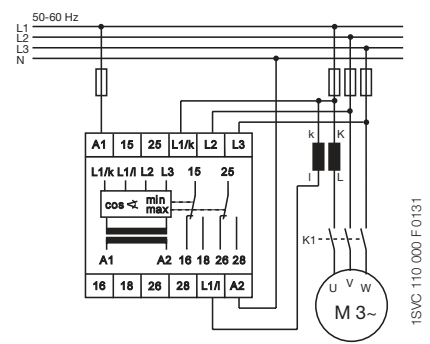

• Current transformers..... 2/103

# Motor load monitoring relays

## Ordering details



CM-LWN

1SVR 450 335 R0100

### Description

The motor load monitor CM-LWN monitors the load of single-phase and three-phase asynchronous motors. The evaluation of the phase angle between current and voltage ( $\cos \phi$  monitoring) allows a very precise monitoring of the load status.

### Ordering details

Rated control supply voltage = measuring voltage	Current range	Type	Order code	Price	Weight (1 pce)
				1 pce	kg (lb)
24-240 V AC/DC	0.5-5 A	CM-LWN	1SVR450335R0000		0.30 (0.66)
110-130 V AC			1SVR450330R0000		0.30 (0.66)
220-240 V AC			1SVR450331R0000		0.30 (0.66)
380- 440 V AC			1SVR450332R0000		0.30 (0.66)
480-500 V AC			1SVR450334R0000		0.30 (0.66)
24-240 V AC/DC	2-20 A		1SVR450335R0100		0.30 (0.66)
110-130 V AC			1SVR450330R0100		0.30 (0.66)
220-240 V AC			1SVR450331R0100		0.30 (0.66)
380- 440 V AC			1SVR450332R0100		0.30 (0.66)
480-500 V AC			1SVR450334R0100		0.30 (0.66)

Current transformers see page 2/132.

### Characteristics

- Pump monitoring
- Under- and overload monitoring  $\cos \phi$  and  $\cos \phi$  in one unit
- Adjustable starting delay 0.3-30 s
- Direct measurement of currents up to 20 A
- Adjustable response time delay 0.2-2 s
- Single-phase or three-phase monitoring
- 2 x 1 c/o contact, closed-circuit principle
- 3 LEDs for status indication



# Motor load monitoring relays

## Technical information

2

The **CM-LWN** module monitors the load status of inductive loads.

The primary application is the monitoring of single- or three-phase asynchronous motors (squirrel cage) under varying load conditions. The measuring principle is based on the evaluation of the phase shift ( $\varphi$ ) between the voltage and the current in one phase.

The phase difference is nearly inversely proportional to the load. Therefore,  $\cos \varphi$ , measured relatively from 0 to 1, measures the relationship of effective power to apparent power. A value towards 0 indicates low load and a value towards 1 indicates high load.

Threshold values can be set individually for  $\cos \varphi_{\max}$  and  $\cos \varphi_{\min}$ . If the set threshold value is reached, a LED lights up and the relay is de-energized.

If  $\cos \varphi$  returns to the acceptable limits (taking into account the hysteresis), the relay is reset to its original state and the LED flashes permanently to indicate the occurrence of the trip event. This message can be deleted using the reset button or by switching off the supply.

A time delay (Time S) of 0.3 to 30 s can be set for the starting phase of the motor. It is also possible to set a response delay time (Time R) of 0.2 to 2 s to suppress unwanted tripping due to unavoidable short load changes during normal operation.

To guarantee correct operation of the response delay (Time R), the adjusted value for  $\cos \varphi_{\max}$  has to be higher than the value for  $\cos \varphi_{\min}$  plus the hysteresis. Consequently, the overload and underload indication must not be active at the same time.

Due to the internal electrical isolation of the supply circuit and the measuring circuit, it is also possible to use the device in systems with different supply voltages.

### Function diagram CM-LWN

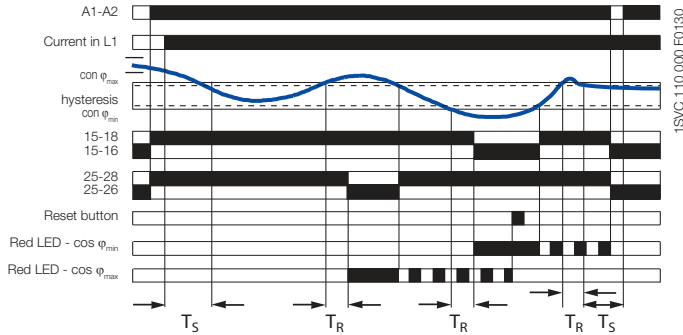

### Connection diagram CM-LWN

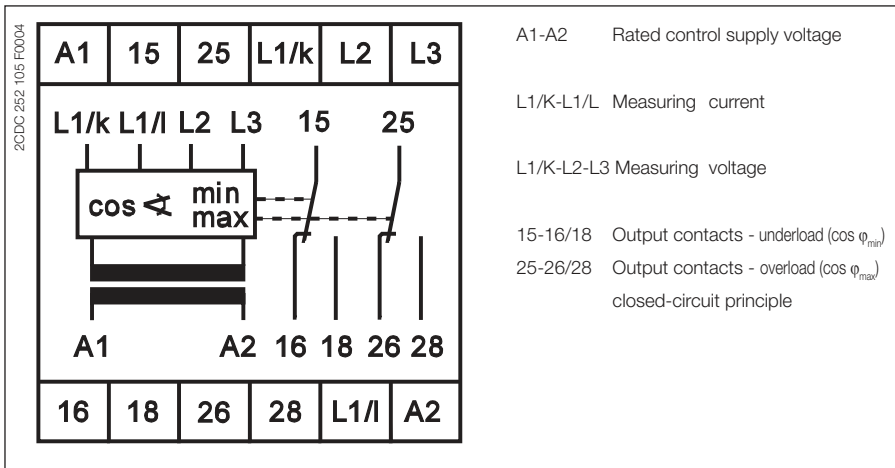

# Motor load monitoring relays

## Technical data

Type		CM-LWN A1-A2
<b>Input circuit - Supply circuit</b>		
Rated control supply voltage $U_s$ - power consumption	A1-A2	24-240 V AC/DC approx. 8.4 VA/W
	A1-A2	110-130 V AC approx. 3.6 VA
	A1-A2	220-240 V AC approx. 3.6 VA
	A1-A2	380-440 V AC approx. 3.6 VA
	A1-A2	480-500 V AC approx. 3.6 VA
Rated control supply voltage $U_s$ tolerance		-15 %...+10 %
Rated frequency	AC versions	50-60 Hz
	AC/DC versions	15-400 Hz or DC
Duty time		100 %
<b>Measuring circuit</b>		L1/L-L1/K-L2-L3
Monitoring function		Motor load monitoring by $\cos \phi$
Voltage range	L1/K-L2-L3	110-500 V AC single-phase or three-phase
Current range	L1/L-L1/K	0.5-5 A version 2-20 A version
Permissible overload of current input		25 A for 3 s 100 A for 3 s
Thresholds		$\cos \phi_{\min}$ and $\cos \phi_{\max}$ adjustable from 0 to 1
Hysteresis (related to phase angle $\phi$ in °)		4°
Frequency of measuring voltage		15-400 Hz
Response time		300 ms
<b>Timing circuits</b>		indication of over- and undervoltage fault
Start-up time (Time S)		0.3-30 s, adjustable
Response delay (Time R)		0.2-2 s, adjustable
Accuracy within the rated control supply voltage tolerance		$\Delta t \leq 0.5 \%$
Accuracy within the temperature range		$\Delta t \leq 0.06 \%$ / °C
<b>Indication of operational states</b>		
Control supply voltage		U: green LED
below $\cos \phi_{\min}$		$\cos \phi_{\min}$ : red LED
$\cos \phi_{\max}$ exceeded		$\cos \phi_{\max}$ : red LED
<b>Output circuits</b>		15-16/18, 25-26/28
Kind of output		2 x 1 c/o contact
Operational principle <sup>1)</sup>		closed-circuit principle
Contact material		AgCdO
Rated voltage (VDE 0110, IEC 664-1, IEC 947-1)		250 V
Max. switching voltage		400 V AC, 300 V DC
Rated operational current $I_s$ (IEC/EN 60947-1)	AC12 (resistive) 230 V	4 A
	AC15 (inductive) 230 V	3 A
	DC12 (resistive) 24 V	4 A
	DC13 (inductive) 24 V	2 A
AC rating (UL 508)	Utilization category (Control Circuit Rating Code)	B 300
	max. rated operational voltage	300 V AC
	max. continuous thermal current at B 300	5 A
	max. making/breaking apparent power at B 300	3600/360 VA
Mechanical lifetime		30 x 10 <sup>6</sup> switching cycles
Electrical lifetime	at AC12, 230 V, 4 A	0.1 x 10 <sup>6</sup> switching cycles
Max. fuse rating to achieve short-circuit protection	n/c / n/o contact	10 A fast-acting / 10 A fast-acting
<b>General data</b>		
Dimensions (W x H x D)		45 mm x 78 mm x 100 mm (1.77 inch x 3.07 inch x 3.94 inch)
Mounting position		any
Degree of protection	housing / terminals	IP50 / IP20
Ambient temperature range	operation / storage	-25...+65 °C / -40...+85 °C
Mounting		DIN rail (IEC/EN 60715)
<b>Electrical connection</b>		
Wire size	fine-strand with wire end ferrule	2 x 2.5 mm <sup>2</sup> (2 x 14 AWG)
<b>Standards</b>		
Product standard		IEC 255-6, EN 60255-6
Low Voltage Directive		2006/95/EC
EMC Directive		2004/108/EC, 91/263/EEC, 92/31/EEC, 93/68/EEC, 93/67/EEC
<b>Electromagnetic compatibility</b>		EN 61000-6-2, EN 61000-6-4
electrostatic discharge	IEC/EN 61000-4-2	Level 3 (6 kV / 8 kV)
radiated, radio-frequency, electromagnetic field	IEC/EN 61000-4-3	Level 3 (10 V/m)
electrical fast transient / burst	IEC/EN 61000-4-4	Level 3 (2 kV / 5 kHz)
surge	IEC/EN 61000-4-5	Level 4 (2 kV L-L)
conducted disturbances, induced by radio-frequency fields	IEC/EN 61000-4-6	Level 3 (10 V)
Operational reliability (IEC 68-2-6)		5 g
Mechanical resistance (IEC 68-2-6)		10 g
Environmental testing (IEC 68-2-30)		24 h cycle time, 55 °C, 93 % rel., 96 h
<b>Isolation data</b>		
Rating (HD 625.1 S1, VDE 0110, IEC 664-1, IEC 60255-5)		250 V, 400 V, 500 V depending on the version
Rated insulation voltage between supply-, measuring- and output circuit		4 kV / 1.2 - 50 $\mu$ s
Rated impulse withstand voltage between all isolated circuits		2.5 kV, 50 Hz, 1 min.
Test voltage between all isolated circuits		3
Pollution category		III
Overvoltage category		III

<sup>1)</sup> Open-circuit principle: Output relay is energized if the measured value exceeds/drops below the adjusted threshold.

Closed-circuit principle: Output relay is de-energized if the measured value exceeds/drops below the adjusted threshold.

# Motor control and protection

## Product group picture

2



# Motor control and protection

## Table of contents

---

<b>Motor control and protection</b>	
Product group picture	2/75
Table of contents	2/76
Benefits and advantages	2/77
Technical data	2/78
Notes	2/80

# Motor control and protection

## Benefits and advantages

2

UMC100-FBP is a flexible, modular and expandable motor management system for constant-speed low-voltage range motors.

It's most important tasks include motor protection, prevention of plant standstills and the reduction of down time. This is made possible by early information relating to possible motor problems which avoids unplanned plant standstills. Even if a motor trips, quick diagnosis of the cause of the fault serves to reduce downtime.

UMC100-FBP combines in a very compact unit:

### Motor protection

- Overload, underload
- Overvoltage, undervoltage
- Blocked rotor, low / high current
- Phase failure, imbalance, phase sequence
- Earth leakage
- Thermistor protection
- Limitation of starts per time
- One single version with integrated measuring system covers the rated motor current from 0,24 to 63 A

### Motor control

- Integrated and easy to parametrize motor starter functions like direct, reverse, star-delta,...
- Additionally free programmable logic for application specific control functions
- Expansion modules DX111, DX122 for more I/Os
- Expansion modules VI150, VI155 for 3-phase voltage measuring

### Motor diagnostics

- Quick and comprehensive access to all relevant data via fieldbus and/or operator panel
- Current, thermal load
- Phase voltages
- Power factor
- Energy

### Communication

- Communication-independent basic device
- Freely selectable fieldbus protocol with FieldBusPlug
- Profibus DP
- DeviceNet
- Modbus
- CANopen

### Typical application segments

- Oil & gas
- Cement
- Paper
- Mining
- Steel
- Chemical industry

Further information

UMC & FBP Catalogue 2CDC 190 022 D0204

UMC & FBP Brochure 2CDC 135 011 B0202

# Motor control and protection

## Technical data



### Basic device UMC100-FBP

UMC100-FBP allows the connection of one I/O-expansion module DX111 or DX122, and one voltage module VI150 or VI155. Expansion modules are connected via 2-wire bus, the max. distance to UMC100-FBP is 3 m.

Main power	
Voltage	max 1000 V AC
Frequency	45 to 65 Hz
Rated motor current	0.24 to 63 A, without accessories
	Greater currents with transformer
Transformer diameter	11 mm (max 25 mm2)
Tripping classes	5, 10, 20, 30, 40 in accordance with EN/IEC 60947-4-1
Short-circuit protection	Separate fuse on network side

Control unit	
Supply voltage	24 V DC
Reverse polarity protection	yes
Inputs	6 digital inputs 24 V DC
	1 PTC input
Outputs	3 relay outputs relay
	1 digital output transistor
Interfaces	1 for ABB FieldBusPlug
	1 for UMC100-PAN control station
	1 for expansion module
Parametric assignment	via fieldbus, control station and / or software
Addressing	Control station or addressing set
LEDs	3 LEDs: green, yellow, red

Environment and mechanical data	
Fastening	on DIN busbar (EN50022-35) or with 4 screws x M4
Dimensions (W x H x D)	70 x 105 x 110 mm (incl. FieldBusPlug and control panel)
Weight	0.39 kg
Terminal cross-section	max. 2.5 mm <sup>2</sup> or 2 x 1.5 mm <sup>2</sup>



### I/O-expansion modules DX111 / DX122

Expansion modules to increase the number of I/Os of a UMC100-FBP. Easy use of inputs by parametrizing for fault or warning; individual message on operator panel configurable.

Supply voltage	24 V DC
Inputs	DX111 8 digital inputs 24 V DC
	DX122 8 digital inputs 110/230 V AC
Outputs	4 relay outputs relay
	1 analogue output, 0/4 to 20 mA / 0 to 10 V configurable
Fastening	on DIN busbar (EN50022-35)
Dimensions (W x H x D)	45 x 77 x 100 mm (without terminal block)

# Motor control and protection

## Technical data

2

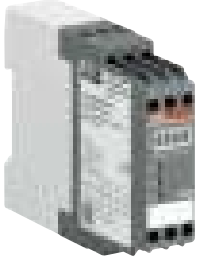

### Voltage expansion modules

Measures the 3 phase voltages of a motor. Different versions for use in grounded and ungrounded networks.

Supply voltage		24 V DC
Inputs	VI150	3 analogue inputs 150 - 690 V AC
		For use in grounded networks
		Maximum operation altitude 2000 m
Inputs	VI155	3 analogue inputs 150 - 690 V AC
		For use in all networks
		Maximum operation altitude > 2000 m
Outputs		1 relay output
Fastening		on DIN busbar (EN50022-35)
Dimensions (W x H x D)		22.5 x 77 x 100 mm (without terminal block)

### Control panel UMC100-PAN

Installation on the device or on the switching cabinet door

Graphics-enabled and backlit display, 3 LEDs for status indication

Freely configurable error messages

Multilingual: German, English, French, Italian, Portuguese, Spanish, Russian

# Motor control and protection Notes

Lined area for notes, consisting of horizontal dashed lines.



# Thermistor motor protection relays

## Product group picture

2



# Thermistor motor protection relays

## Table of contents

---

<b>Thermistor motor protection relays</b>	
Product group picture	2/81
Table of contents	2/82
Benefits and advantages, Selection table	2/83
Product overview	2/84
Ordering details	2/86
Ordering details - PTC temperature sensors C011	2/87
Technical information - PTC temperature sensors C011	2/88
Technical data	2/89

# Thermistor motor protection relays

## Benefits and advantages, Selection table

### Operating principle and fields of application for thermistor motor protection relays

The CM range of thermistor motor protection relays are used to control motors equipped with PTC temperature sensors. The PTC temperature sensors are incorporated in the motor windings to measure the motor heating. This enables direct control and evaluation of the following operating conditions:

- heavy duty starting
- increased switching frequency
- single-phase operation
- high ambient temperature
- insufficient cooling
- break operation
- unbalance

The relay is independent of the rated motor current, the insulation class and the method of starting.

The PTC sensors are connected in series to the terminals  $T_a$  and  $T_b$  (or  $T_a$  and  $T_{bx}$  without short-circuit detection). The number of possible PTC sensors per measuring circuit is limited by the sum of the individual PTC sensor resistances:  $R_G = R_1 + R_2 + R_N \leq 1.5 \text{ k}\Omega$ .

Under normal operating conditions the resistance is below the response threshold. If only one of the PTC resistors heats up excessively, the output relay de-energizes. If the autoreset function is configured, the output relay energizes automatically after cooling down.

Devices with manual (pushbutton on front-side) or remote reset configuration have to be controlled via the control input by the required signal.

#### Further applications:

Temperature monitoring of equipment with PTC sensors integrated, such as

- machine rolling bearings,
- hot-air ventilators,
- oil,
- air,
- heating installations, etc.

#### Resistance characteristic

for one single temperature sensor acc. to DIN 44 081.

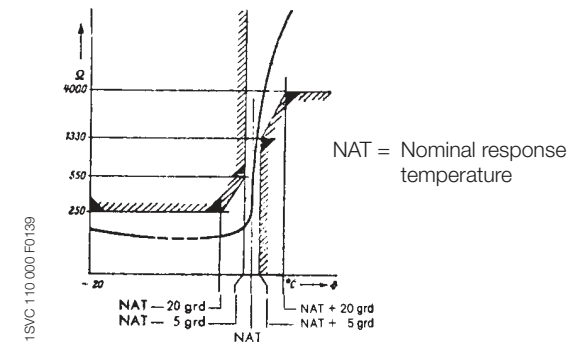

### Selection table thermistor motor protection relays

Type	CM-MSE	CM-MSS (1)	CM-MSS (2)	CM-MSS (3)	CM-MSS (4)	CM-MSS (5)	CM-MSS (6)	CM-MSS (7)	CM-MSN
Function									
Measuring range									
Number of sensor circuits	1	1	1	1	1	1	2	3	6
Wire break monitoring	●	●	●	●	●	●	●	●	●
Short-circuit detection	–	–	–	● <sup>1)</sup>	●	●	●	●	●
Non-volatile fault storage	–	–	–	–	● <sup>2)</sup>	● <sup>2)</sup>	–	● <sup>2)</sup>	● <sup>2)</sup>
Operation/Reset									
Auto reset	●	●	●	●	● <sup>2)</sup>	● <sup>2)</sup>	● <sup>2)</sup>	● <sup>2)</sup>	● <sup>2)</sup>
Manual reset	–	–	●	●	●	●	●	●	●
Remote reset	–	–	●	●	●	●	●	●	●
Test button	–	–	–	–	●	●	●	●	●
Output contacts									
Operational principle	closed-circuit principle								
Number / type	1 n/o	1 c/o	2 c/o	2 c/o	1 n/o + 1 n/c	2 c/o	1 c/o per sensor circuit	1 n/o + 1 n/c accumulative evaluation	1 n/o + 1 n/c accumulative evaluation
Width of housing	22.5 mm								45 mm
Supply voltages and order codes	1SVR550805R9300	1SVR430800R9100	1SVR430811R9300	1SVR430710R9300					
24 V AC/DC			1SVR430810R9300	1SVR430711R9300					
110-130 V AC	1SVR550800R9300		1SVR430811R0300	1SVR430711R0300					
220-240 V AC	1SVR550801R9300	1SVR430801R1100	1SVR430811R1300	1SVR430711R1300					
380-440 V AC				1SVR430711R2300					
24-240 V AC/DC					1SVR430720R0400	1SVR430720R0300	1SVR430710R0200	1SVR430720R0500	1SVR450025R0100

1) configurable via terminals

2) Auto reset without non-volatile fault storage configurable by permanent jumpering of connection terminals S1-T2 or S1/X1-S2/X2

# Thermistor motor protection relays

## Product overview

### CM-MSE

- Auto reset
- Connection of several sensors (max. 6 sensors conn. in series)
- Monitoring of bimetals
- 1 n/o contact
- Excellent cost / performance ratio

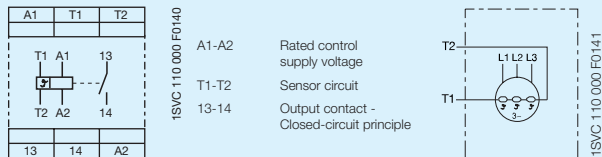

1SVC 110 000 F0140  
 A1-A2 Rated control supply voltage  
 T1-T2 Sensor circuit  
 13-14 Output contact - Closed-circuit principle

### CM-MSS (1), 1 c/o contact

- Auto reset
- Connection of several sensors
- Monitoring of bimetals
- 1 c/o contact
- 2 LEDs for status indication

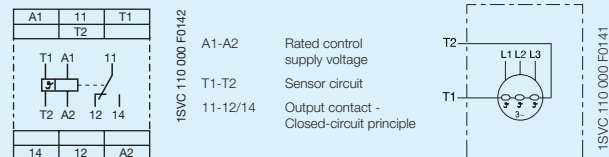

1SVC 110 000 F0142  
 A1-A2 Rated control supply voltage  
 T1-T2 Sensor circuit  
 11-12/14 Output contact - Closed-circuit principle

### CM-MSS (2), 2 c/o contacts

- Fault storage can be switched off
- Auto reset configurable
- Reset button
- Remote reset
- Monitoring of bimetals
- 2 c/o contacts
- 2 LEDs for status indication

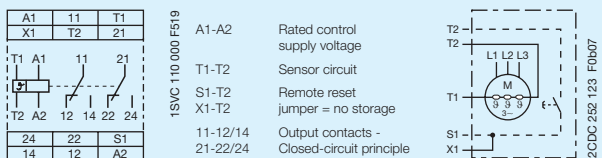

1SVC 110 000 F519  
 A1-A2 Rated control supply voltage  
 T1-T2 Sensor circuit  
 S1-T2 Remote reset jumper = no storage  
 X1-T2 Remote reset  
 11-12/14 Output contacts - Closed-circuit principle  
 21-22/24

### CM-MSS (3), 2 c/o contacts, short-circuit monitoring configurable

- Fault storage can be switched off
- Auto reset configurable
- Reset button
- Remote reset
- Monitoring of bimetals
- Short-circuit monitoring of the sensor circuit configurable
- 2 c/o contacts
- 2 LEDs for status indication

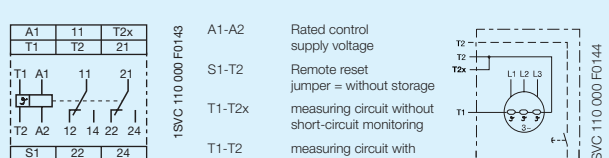

1SVC 110 000 F0143  
 A1-A2 Rated control supply voltage  
 S1-T2 Remote reset jumper = without storage  
 T1-T2x measuring circuit without short-circuit monitoring  
 T1-T2 measuring circuit with short-circuit monitoring  
 11-12/14 Output contacts - Closed-circuit principle  
 21-22/24

### CM-MSS (4) + CM-MSS (5), 1-channel

- Short-circuit monitoring of the sensor circuit
- Wide supply voltage range: 24-240 V AC/DC
- Non-volatile fault storage selectable
- Reset and test button
- Remote reset
- Auto reset configurable
- Output contacts: 1 n/c and 1 n/o or 2 c/o contacts
- 2 LEDs for status indication

### CM-MSS (4)

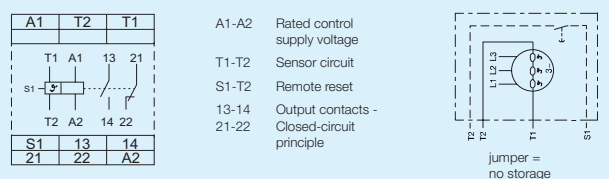

1SVC 110 000 F0145  
 A1-A2 Rated control supply voltage  
 T1-T2 Sensor circuit  
 S1-T2 Remote reset  
 13-14 Output contacts - Closed-circuit principle  
 21-22 Remote reset  
 jumper = no storage

### CM-MSS (5)

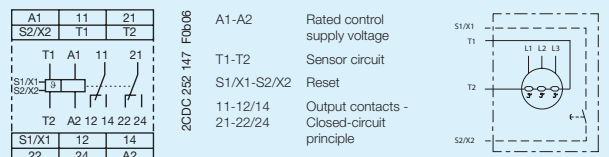

2CDC 252 147 F0b06  
 A1-A2 Rated control supply voltage  
 T1-T2 Sensor circuit  
 S1/X1-S2/X2 Reset  
 11-12/14 Output contacts - Closed-circuit principle  
 21-22/24

# Thermistor motor protection relays

## Product overview

2

### CM-MSS (6), 2-channel, single evaluation

- Short-circuit monitoring for the sensor circuits
- Wide supply voltage range: 24-240 V AC/DC
- 2 separate sensor circuits for monitoring of two motors or one motor with 2 sensor circuits (prewarning and final switch off)
- Reset button
- Auto reset configurable
- Output contacts: 2 x 1 c/o contact
- 3 LEDs for status indication

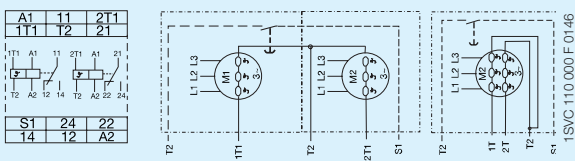

A1-A2 Rated control supply voltage  
 11-12/14, 21-22/24 Output contacts - Closed-circuit principle  
 1T1-T2 Sensor circuit  
 2T1-T2 S1-T2 jumpered = no storage

### CM-MSS (7), 3 sensor circuits, accumulative evaluation

- Short-circuit monitoring for the sensor circuits
- Wide supply voltage range: 24-240 V AC/DC
- Non-volatile fault storage configurable
- Remote reset
- Auto reset configurable
- Reset and test button
- Output contacts: 1 n/c and 1 n/o contact
- 4 LEDs for status indication

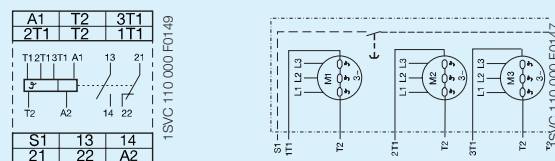

A1-A2 Rated control supply voltage  
 13-14 Output contacts - Closed-circuit principle  
 21-22 S1-T2 Remote reset jumpered = no storage

### CM-MSN, 6 sensor circuits, accumulative evaluation

- Short-circuit monitoring of the sensor circuit
- Wide supply voltage range: 24-240 V AC/DC
- Non-volatile fault storage configurable
- Remote reset
- Auto reset configurable
- Reset and test button
- Output contacts: 1 n/c, 1 n/o contact
- 7 LEDs for status indication

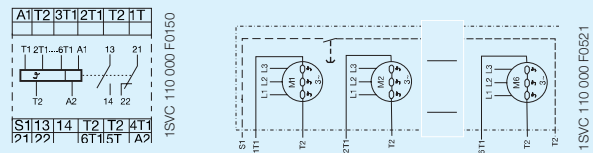

A1-A2 Rated control supply voltage  
 13-14 Output contacts - Closed-circuit principle

accumulative evaluation = if any input exceeds the threshold, the output relay will trip

# Thermistor motor protection relays

## Ordering details

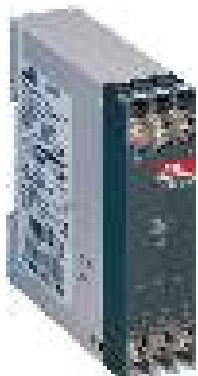

2CDC 251 012 F0003

CM-MSE

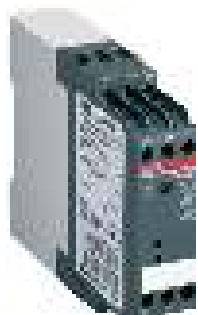

2CDC 251 047 F0004

CM-MSS (5)



1SVR 450 025 F0000

CM-MSN

### Description

The thermistor motor protection relays CM-MSE, CM-MSS and CM-MSN are used to control motors equipped with PTC temperature sensors. The PTC temperature sensors are incorporated in the motor windings to measure the motor heating. This enables direct control and evaluation of various operating conditions. Depending on the products also ATEX approvals for use in hazardous areas are available.

ABB also offers PTC temperature sensors C011 (according to DIN 44081) which are suitable for embedding in motor windings.

### Ordering details

Rated control supply voltage = measuring voltage	Type	Order code	Price 1 pce	Weight (1 pce) kg (lb)
24 V AC	CM-MSE	1SVR550805R9300		0.11 (0.24)
110-130 V AC		1SVR550800R9300		0.11 (0.24)
220-240 V AC		1SVR550801R9300		0.11 (0.24)
24 V AC/DC <sup>1)</sup>	CM-MSS (1)	1SVR430800R9100		0.15 (0.33)
220-240 V AC		1SVR430801R1100		0.15 (0.33)
24 V AC/DC <sup>1)</sup>	CM-MSS (2)	1SVR430810R9300		0.15 (0.33)
24 V AC		1SVR430811R9300		0.15 (0.33)
110-130 V AC		1SVR430811R0300		0.15 (0.33)
220-240 V AC	CM-MSS (3) <sup>4)</sup>	1SVR430811R1300		0.15 (0.33)
24 V AC/DC <sup>1)</sup>		1SVR430710R9300		0.15 (0.33)
110-130 V AC		1SVR430711R0300		0.15 (0.33)
220-240 V AC	CM-MSS (4) <sup>2) 4)</sup>	1SVR430711R1300		0.15 (0.33)
380-440 V AC		1SVR430711R2300		0.15 (0.33)
24-240 V AC/DC	CM-MSS (5) <sup>3) 4)</sup>	1SVR430720R0400		0.15 (0.33)
	CM-MSS (6) <sup>4)</sup>	1SVR430720R0300		0.15 (0.33)
	CM-MSS (7) <sup>4)</sup>	1SVR430710R0200		0.15 (0.33)
	CM-MSS (7) <sup>4)</sup>	1SVR430720R0500		0.15 (0.33)
	CM-MSN <sup>4)</sup>	1SVR450025R0100		0.23 (0.51)

<sup>1)</sup> Not electrically isolated

<sup>2)</sup> CM-MSS (4): 1-channel 1 n/c, 1 n/o

<sup>3)</sup> CM-MSS (5): 1-channel 2 c/o

<sup>4)</sup>

# Thermistor motor protection relays

## Ordering details - PTC temperature sensors C011

2



1SVC 110 000 F0531

### Temperature sensor characteristics

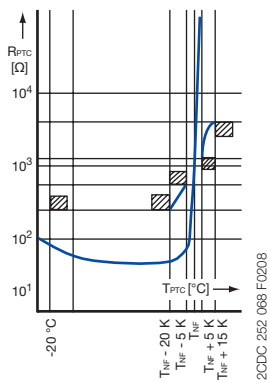

2CDC 252 065 F0208

### Description

The PTC temperature sensors (temperature-dependent with positive temperature coefficient) are selected by the manufacturer of the motor depending on:

- the motor insulation class according to IEC/EN 60034-11,
- the special characteristics of the motor, such as the conductor cross-section of the windings, the permissible overload factor etc.
- special conditions prescribed by the user, such as the permissible ambient temperature, risks resulting from locked rotor, extent of permitted overload etc.

One temperature sensor must be embedded in each phase winding. For instance, in case of three-phase squirrel cage motors, three sensors are embedded in the stator windings. For pole-changing motors with one winding (Dahlander connection), 3 sensors are also sufficient. Pole-changing motors with two windings, however, require The sensors are suitable for embedding in motor windings with rated operating voltages of up to 600 V AC. Conductor length: 500 mm per sensor. A 14 V varistor can be connected in parallel to protect the sensors from overvoltage. Due to their characteristics, the thermistor motor protection relays can also be used with PTC temperature sensors of other manufacturers which comply with DIN 44 081 and DIN 44 082 6 sensors.

If an additional warning is required before the motor is switched off, separate sensors for a correspondingly lower temperature must be embedded in the winding. They have to be connected to a second control unit.

### Ordering details

Rated response temperature $T_{NF}$	Color Coding	Type	Order code	Price 1 pce	Weight (1 pce) kg (lb)
70 °C	white-brown	C011-70 <sup>1)</sup>	GHC0110003R0001		0.02 (0.044)
80 °C	white-white	C011-80 <sup>1)</sup>	GHC0110003R0002		0.02 (0.044)
90 °C	green-green	C011-90 <sup>1)</sup>	GHC0110003R0003		0.02 (0.044)
100 °C	red-red	C011-100 <sup>1)</sup>	GHC0110003R0004		0.02 (0.044)
110 °C	brown-brown	C011-110 <sup>1)</sup>	GHC0110003R0005		0.02 (0.044)
120 °C	gray-gray	C011-120 <sup>1)</sup>	GHC0110003R0006		0.02 (0.044)
130 °C	blue-blue	C011-130 <sup>1)</sup>	GHC0110003R0007		0.02 (0.044)
140 °C	white-blue	C011-140 <sup>1)</sup>	GHC0110003R0011		0.02 (0.044)
150 °C	black-black	C011-150 <sup>1)</sup>	GHC0110003R0008		0.02 (0.044)
160 °C	blue-red	C011-160 <sup>1)</sup>	GHC0110003R0009		0.02 (0.044)
170 °C	white-green	C011-170 <sup>1)</sup>	GHC0110003R0010		0.02 (0.044)
150 °C	black-black	C011-3-150 <sup>2)</sup>	GHC0110033R0008		0.05 (0.11)

<sup>1)</sup> Temperature sensor C011, standard version acc. to DIN 44081

<sup>2)</sup> Triple temperature sensor C011-3

# Thermistor motor protection relays

## Technical information - PTC temperature sensors C011

### Technical data

Characteristic data	Sensor type C011
Cold-state resistance	50 -100 $\Omega$ at 25 °C
Warm-state resistance $\pm 5$ up to 6 K of rated response temperature $T_{NF}$	10 000 $\Omega$
Thermal time constant, sensor open <sup>1)</sup>	< 5 s
Permitted ambient temperature	+180 °C

2

Rated response temperature $\pm$ tolerance $T_{NF} \pm \Delta T_{NF}$	PTC resistance R from -20 °C to $T_{NF} - 20$ K	PTC resistance R at PTC temperatures of:			
		$T_{NF} - \Delta T_{NF}$ (UPTC $\leq 2.5$ V)	$T_{NF} + \Delta T_{NF}$ (UPTC $\leq 2.5$ V)	$T_{NF} + 15$ K (UPTC $\leq 7.5$ V)	
70 $\pm 5$ °C	$\leq 100 \Omega$	$\leq 570 \Omega$	$\geq 570 \Omega$	-	
80 $\pm 5$ °C					
90 $\pm 5$ °C					
100 $\pm 5$ °C					
110 $\pm 5$ °C					
120 $\pm 5$ °C					
130 $\pm 5$ °C			$\leq 550 \Omega$	$\geq 1330 \Omega$	$\geq 4000 \Omega$
140 $\pm 5$ °C					
150 $\pm 5$ °C					
160 $\pm 5$ °C					
170 $\pm 7$ °C		$\leq 570 \Omega$	$\geq 570 \Omega$	-	

<sup>1)</sup> Not embedded in windings.

<sup>2)</sup> For triple temperature sensor take values x 3.



# Thermistor motor protection relays

## Technical data

2

Type		CM-MSE	CM-MSS	CM-MSN
<b>Input circuit</b>				
Rated control supply voltage $U_s$ power consumption	A1-A2	24 V AC approx. 1.5 VA		
	A1-A2	24 V AC/DC approx. 1.1 VA / 0.6 W		
	A1-A2	110-130 V AC approx. 1.5 VA		
	A1-A2	220-240 V AC approx. 1.5 VA		
	A1-A2	380-440 V AC approx. 1.7 VA		
	A1-A2	24-240 V AC/DC approx. 1.4-1.7 W / approx. 3.5-5.7 VA		
Rated control supply voltage $U_s$ tolerance		-15 % ... +10 %		
Rated frequency		AC: 50-60 Hz / 24-240 V AC/DC versions: 15-400 Hz		
Duty time		100 %		
<b>Measuring circuit</b>		<b>T1-T2</b>	<b>T1-T2/T2x, 1T1...6T1-T2</b>	<b>1T1...6T1-T2</b>
Monitoring function		temperature monitoring by means of PTC sensors		
Number of sensor circuits		1	1, 2 oder 3 (see order. details)	6
Short-circuit monitoring		-	see ordering details	yes
Non-volatile fault storage		-	see ordering details	configurable
Test function		-	see ordering details	yes
<b>Sensor circuit</b>				
Temperature threshold (relay de-energizes)		2.7-3.7 k $\Omega$	CM-MSS (1+2): 3050 $\pm$ 550 $\Omega$ CM-MSS (3-7): 3.6 k $\Omega$ $\pm$ 5 %	3.6 k $\Omega$ $\pm$ 5 %
Temperature hysteresis (relay energizes)		1.7-2.3 k $\Omega$	CM-MSS (1+2): 1900 $\pm$ 400 $\Omega$ CM-MSS (3-7): 1.6 k $\Omega$ $\pm$ 5 %	1.6 k $\Omega$ $\pm$ 5 %
Short-circuit threshold (relay de-energizes)		<18 $\Omega$		
Short-circuit hysteresis (relay energizes)		>45 $\Omega$		
Maximum total resistance of sensors connected in series (cold state)		$\leq$ 1.5 k $\Omega$		
Maximum sensor cable length for short-circuit detection		2 x 100 m at 0.75 mm <sup>2</sup> , 2 x 400 m at 2.5 mm <sup>2</sup>		
Response time		<100 ms		
<b>Control circuit for storage and hysteresis function</b>				
Remote reset	S1-T2 or S1/X1-S2/X2	-	n/o contact	
Maximum no-load voltage		-	approx. 25 V, 24-240 V; AC/DC versions: 5.5 V	
Maximum cable length		-	$\leq$ 50 m, 100-200 m if shielded	
<b>Indication of operational states</b>				
Control supply voltage	U: green LED	-	□: control supply voltage applied	
Fault indication	F: red LED	-	□: output relay de-energized	
<b>Output circuits</b>		<b>13-14</b>	<b>11-12/14, 21-22/24, 13-14, 21-22</b>	<b>13-14, 21-22</b>
Kind of output		1 n/o contact	CM-MSS (1): 1 c/o contact CM-MSS (2,3,5): 2 c/o contacts CM-MSS (4, 7): 1 n/o + 1 n/c CM-MSS (6): 2x1 c/o contact	1 n/o + 1 n/c contact
Operational principle		closed-circuit principle (output relay de-energizes if the measured value exceeds/drops below the adjusted threshold)		
Contact material		AgCdO	CM-MSS (1+2+6): AgCdO CM-MSS (3+4+5+7): AgNi	AgNi
Rated voltage (VDE 0110, IEC 664-1, IEC 60947-1)		250 V		
Maximum switching voltage		250 V		
Rated operational current $I_n$ (IEC/EN 60947-5-1)	AC12 (resistive) at 230 V	4 A		
	AC15 (inductive) at 230 V	3 A		
	DC12 (resistive) at 24 V	4 A		
	DC13 (resistive) at 24 V	2 A (1.5 A - n/c contact <sup>1)</sup> )		
AC rating (UL 508)	Utilization category (Control Circuit Rating Code)			
	max. rated operational voltage	300 V AC		
	max. continuous thermal current at B 300	5 A		
	max. making/breaking apparent power at B300	3600/360 VA		
Mechanical lifetime		30 (10 <sup>-3</sup> ) x 10 <sup>6</sup> switching cycles		
Electrical lifetime (AC12, 230 V, 4 A)		0.1 x 10 <sup>6</sup> switching cycles		
Max. fuse rating to achieve short-circuit protection	n/c contact	10 A fast-acting	4 A (10 A <sup>1)</sup> fast-acting	10 A fast-acting
	n/o contact	10 A fast-acting	6 A (10 A <sup>1)</sup> fast-acting	10 A fast-acting
<b>General data</b>				
Dimensions (W x H x D)		22.5 x 78 x 78.5 mm (0.89 x 3.07 x 3.09 in)	22.5 x 78 x 100 mm (0.89 x 3.07 x 3.94 in)	45 x 78 x 100 mm (1.77 x 3.07 x 3.94 in)
Weight		approx. 0.11 kg (0.24 lb)	approx. 0.15 kg (0.33 lb)	approx. 0.23 kg (0.51 lb)
Mounting position		any		
Degree of protection	housing / terminals	IP50 / IP20		
Ambient temperature range	operation	-20...+60 °C		
	storage	-40...+85 °C		
Mounting		DIN rail (IEC/EN 60715)		

<sup>1)</sup> 1SVR 430 710 R 0200, 1SVR 430 8xx R xxxx

# Thermistor motor protection relays

## Technical data

Type		CM-MSE	CM-MSS	CM-MSN
<b>Electrical connection</b>				
Wire size	fine strand with wire end ferrule	2 x 1.5 mm <sup>2</sup> (2 x 16 AWG)	2 x 2.5 mm <sup>2</sup> (2 x 14 AWG)	
	fine strand without wire end ferrule	2 x 0.75-1.5 mm <sup>2</sup> (2 x 18-16 AWG)	2 x 0.75-2.5 mm <sup>2</sup> (2 x 18-14 AWG)	
	rigid	2 x 1-1.5 mm <sup>2</sup> (2 x 18-16 AWG)	2 x 0.75-2.5 mm <sup>2</sup> (2 x 18-14 AWG)	
Stripping length		2 x 0.75-1.5 mm <sup>2</sup> (2 x 18-16 AWG)	2 x 0.5-4 mm <sup>2</sup> (2 x 20-12 AWG)	
Tightening torque		10 mm (0.39 inch)	7 mm (0.28 inch)	
<b>Standards</b>				
Product standard		IEC 255-6, EN 60255-6		
Low Voltage Directive		2006/95/EC		
EMC Directive		2004/108/EC, 91/263/EEC, 92/31/EEC, 93/68/EEC, 93/67/EEC		
<b>Electromagnetic compatibility</b>		<b>EN 61000-6-2, EN 61000-6-4</b>		
electrostatic discharge	IEC/EN 61000-4-2	Level 3 (6 kV / 8 kV)		
radiated, radio-frequency, electromagnetic field	IEC/EN 61000-4-3	Level 3 (10 V/m)		
electrical fast transient /burst	IEC/EN 61000-4-4	Level 3 (2 kV / 5 kHz)		
surge	IEC/EN 61000-4-5	Level 3/4 (1/2 kV)		
conducted disturbances, induced by radio-frequency fields	IEC/EN 61000-4-6	Level 3 (10 V)		
Operational reliability (IEC 68-2-6)		6 g	4 g	5 g
Resistance to vibration (IEC 68-2-6)		10 g	6 g	10 g
Environmental testing (IEC 68-2-30)		24 h cycle time, 55 °C, 93 % rel., 96 h		
<b>Isolation data</b>				
Rated voltage between supply, measuring and output circuit		250 V		
Rated impulse withstand voltage between all isolated circuits		4 kV / 1.2 - 50 μs		
Test voltage between all isolated circuits		2.5 kV, 50 Hz, 1 min.		
Pollution degree		3		
Overvoltage category		III		

# Temperature monitoring relays

## Product group picture

2



# Temperature monitoring relays

## Table of contents

---

<b>Temperature monitoring relays</b>	
Product group picture	2/91
Table of contents	2/92
Benefits and advantages	2/93
Selection and conversion	2/94
Ordering details	2/95
Overview, functional description and diagrams	2/96
Connection diagrams, Resistance thermometer sensors	2/98
Technical data	2/99
Notes	2/102

# Temperature monitoring relays

## Benefits and advantages

2

### New range of temperature monitoring relays CM-TCS

The new CM-TCS temperature monitoring relays replace the existing C510 and C511 range. The numbers of references have been reduced in order to make the selection and stock keeping easier. All products feature now over-temperature and under-temperature monitoring. Also the working principle is configurable: open or closed circuit principle.

The temperature monitoring relays CM-TCS monitor overtemperature, undertemperature or temperatures between threshold values (window monitoring) with PT100 sensor. As soon as the temperature falls below or exceeds the threshold value the output relays change their positions according to the configured functionality and the front-face LED's display the current status.

#### Characteristics CM-TCS

- Adjustable sensor type: PT100
- Functionality like overtemperature monitoring, undertemperature monitoring, temperature window monitoring configurable
- All configurations and adjustments by front-face operating elements
- Precise adjustment with direct reading scales
- One or two threshold values
- Hysteresis 2...20 % adjustable
- Operating temperature range -40...+60 °C
- 1 x 2 c/o or 2 x 1 c/o configurable
- Open- or closed-circuit principle configurable
- Short-circuit monitoring and interrupted wire detection
- 22.5 mm (0.89 in) width
- LED's for status indication

#### Characteristics C512 + C513

- Adjustable sensor types: PT100, PT1000, KTY83, KTY84, NTC-B57227-K333-A1
- Measuring principle for 2-wire and 3-wire sensors
- Temperature monitor for 1-3 sensor circuits
- Adjustable over-, undertemperature monitoring or range monitoring function
- 2 thresholds
- Hysteresis for both thresholds (1-99 Kelvin)
- Adjustable time delay from 0-999 s affects to both thresholds
- Storage function selectable via external signal (Y1-Y2)
- Non volatile storage of parameter settings
- 1 n/o (for wire-break and short-circuit detection) and 2 c/o
- Multifunctional digital display
- 3 LED's for status indication
- Open- or closed-circuit principle selectable
- 45 mm wide housing with 24 terminals

#### C512

- Temperature monitor for 1 sensor circuit

#### C513

- Temperature monitor for 1-3 sensor circuits
- In the 3-sensor version the status of the single sensors is displayed if the temperature exceeds or falls below the threshold.

This way it can be easily determined which one of the connected sensors has exceeded or dropped below either one or both threshold values.

# Temperature monitoring relays

## Selection and conversion

	Existing range <sup>2)</sup>												New range <sup>1)</sup>			
	Type	Order number											Type	Order number		
	CM-TCS.21	1SVR 630 740 R9100											CM-TCS.21S	1SVR 730 740 R9100		
													CM-TCS.21P	1SVR 740 740 R9100		
	CM-TCS.11	1SVR 630 740 R0100											CM-TCS.11S	1SVR 730 740 R0100		
													CM-TCS.11P	1SVR 740 740 R0100		
	CM-TCS.22	1SVR 630 740 R9200											CM-TCS.22S	1SVR 730 740 R9200		
													CM-TCS.22P	1SVR 740 740 R9200		
	CM-TCS.12	1SVR 630 740 R0200											CM-TCS.12S	1SVR 730 740 R0200		
													CM-TCS.12P	1SVR 740 740 R0200		
	CM-TCS.23	1SVR 630 740 R9300											CM-TCS.23S	1SVR 730 740 R9300		
													CM-TCS.23P	1SVR 740 740 R9300		
	CM-TCS.13	1SVR 630 740 R0300											CM-TCS.13S	1SVR 730 740 R0300		
													CM-TCS.13P	1SVR 740 740 R0300		
	C512-24	1SAR 700 016 R0005														
	C512-W	1SAR 700 016 R0010														
	C513-W	1SAR 700 016 R0010														
<b>Rated control supply voltage U<sub>s</sub></b>																
24 V AC/DC																
24-240 V AC/DC	■	■		■	■		■	■		■	■		■	■		
<b>Technology</b>																
analogue	■	■	■	■	■	■	■	■	■	■	■	■	■	■	■	
digital														■	■	
<b>Sensor circuits (2 or 3 wire)</b>																
no of temperature sensors	1	1	1	1	1	1	1	1	1	1	1	1	1	1	1	3
no of thresholds	2	2	2	2	2	2	2	2	2	2	2	2	2	2	2	3
<b>Sensor type</b>																
PT100	■	■	■	■	■	■	■	■	■	■	■	■	■	■	■	■
PT100, KTY83, KTY84, NTC															■	■
<b>Measuring temperature range</b>																
-50...+50 °C	■	■	■	■												
0...+100 °C					■	■	■	■								
0...+200 °C										■	■	■	■			
-50...+500 °C															■	■
<b>Monitoring function</b>																
overtemperature	■	■	■	■	■	■	■	■	■	■	■	■	■	■	■	■
undertemperature	■	■	■	■	■	■	■	■	■	■	■	■	■	■	■	■
window temperature	■	■	■	■	■	■	■	■	■	■	■	■	■	■	■	■
<b>Operating principle</b>																
open or closed principle	■	■	■	■	■	■	■	■	■	■	■	■	■	■	■	■
<b>Output contacts</b>																
n/o															1	1
c/o	2	2	2	2	2	2	2	2	2	2	2	2	2	2	2	2

<sup>1)</sup> available 4th quarter 2012  
<sup>2)</sup> Existing range will be available until release of new generation

# Temperature monitoring relays

## Ordering details

2



CM-TCS

2CDC 251 002 S0010



C512, C513

1SVC 110 000 P0557

<sup>1)</sup> PT100 sensors, 2 or 3 wire connection, 2 thresholds adjustable  
<sup>2)</sup> PT100, PT1000, KTY83, KTY84, NTC-B57227-K333-A1, 2 or 3 wire connection, 2 thresholds, multifunctional display. Open or closed circuit principle adjustable, 1 n/o, 2 c/o contacts

### Description

Acquisition, messaging and regulation of temperatures of solid, liquid and gaseous media in processes and machines via PT100, PT1000, KTY83, KTY84 or NTC sensors. ABB offers different temperature monitoring relays to meet the needs of your application:

### Ordering details - Temperature monitoring relays

Rated control supply voltage	Measuring range	Type	Order code	Price	Weight (1 pce)
				1 pce	kg (lb)
24-240 V AC/DC	-50...+50 °C	CM-TCS.11 <sup>1)</sup>	1SVR630740R0100		0.127 (0.281)
	0...+100 °C	CM-TCS.12 <sup>1)</sup>	1SVR630740R0200		0.127 (0.281)
	0...+200 °C	CM-TCS.13 <sup>1)</sup>	1SVR630740R0300		0.127 (0.281)
24 V AC/DC	-50...+50 °C	CM-TCS.21 <sup>1)</sup>	1SVR630740R9100		0.141 (0.310)
	0...+100 °C	CM-TCS.22 <sup>1)</sup>	1SVR630740R9200		0.141 (0.310)
	0...+200 °C	CM-TCS.23 <sup>1)</sup>	1SVR630740R9300		0.141 (0.310)
24 V AC/DC		C512-24 <sup>2)</sup>	1SAR700100R0005		0.32 (0.71)
24-240 V AC/DC	-50...+500 °C *)	C512-W <sup>2)</sup>	1SAR700100R0010		0.33 (0.73)
24-240 V AC/DC		C513-W <sup>2)</sup>	1SAR700110R0010		0.34 (0.75)

### Ordering details - Temperature monitoring relays new range available at 4th quarter of 2012

Rated control supply voltage	Measuring range	Type	Order code	Price	Weight (1 pce)
				1 pce	kg (lb)
24-240 V AC/DC	-50...+50 °C	CM-TCS.11S <sup>1)3)</sup>	1SVR730740R0100		0.151 (0.333)
		CM-TCS.11P <sup>1)3)</sup>	1SVR740740R0100		0.140 (0.309)
		CM-TCS.12S <sup>1)3)</sup>	1SVR730740R0200		0.151 (0.333)
	0...+100 °C	CM-TCS.12P <sup>1)3)</sup>	1SVR740740R0200		0.140 (0.309)
		CM-TCS.13S <sup>1)3)</sup>	1SVR730740R0300		0.151 (0.333)
		CM-TCS.13P <sup>1)3)</sup>	1SVR740740R0300		0.140 (0.309)
24 V AC/DC	-50...+50 °C	CM-TCS.21S <sup>1)3)</sup>	1SVR730740R9100		0.138 (0.304)
		CM-TCS.21P <sup>1)3)</sup>	1SVR740740R9100		0.127 (0.280)
	0...+100 °C	CM-TCS.22S <sup>1)3)</sup>	1SVR730740R9200		0.138 (0.304)
		CM-TCS.22P <sup>1)3)</sup>	1SVR740740R9200		0.127 (0.280)
	0...+200 °C	CM-TCS.23S <sup>1)3)</sup>	1SVR730740R9300		0.138 (0.304)
		CM-TCS.23P <sup>1)3)</sup>	1SVR740740R9300		0.127 (0.280)

### Ordering details - Replaceable cover marking for digital devices

Use for	Language	Type	Order code	Price	Weight (1 pce)
				5 pces	kg (lb)
C512	German	C512-D	1SVR700101R0100		
C512	English	C512-E	1SVR700102R0100		
C513	German	C513-D	1SVR700111R0100		
C513	English	C513-E	1SVR700112R0100		

\*) The measuring range depends on the used sensor type:

- PT100: -50...+500 °C
  - PT1000: -50...+500 °C
  - NTC: +80...+160 °C
  - KTY83: -50...+175 °C
  - KTY84: -40...+300 °C
- (Typ Siemens Matsushita B57272-A333-A1 - 100 °C: 1,8 kΩ, 25 °C: 32,762 kΩ)

# Temperature monitoring relays

## Overview, functional description and diagrams

### Overview

The temperature monitoring relays can be used for temperature measurement in solid, liquid and gaseous media. The temperature is acquired by the sensor in the medium, evaluated by the device and monitored to determine whether it is within an operating range (range monitoring function) or has exceeded or fallen below a threshold.

### Functional description

#### CM-TCS

The temperature monitoring relays CM-TCS monitor overtemperature, undertemperature, or temperatures between two threshold values (window monitoring) with PT100 sensor. As soon as the temperature falls below or exceeds the threshold value the output relays change their positions according to the configured functionality and the front-face LEDs display the current status. Regardless of the selected configuration, the device is monitoring its measuring circuit for interrupted wires or short-circuits.

#### DIP switches

Position	4	3	2	1
ON ↑				
OFF				

### Function diagrams

#### CM-TCS - Overvoltage

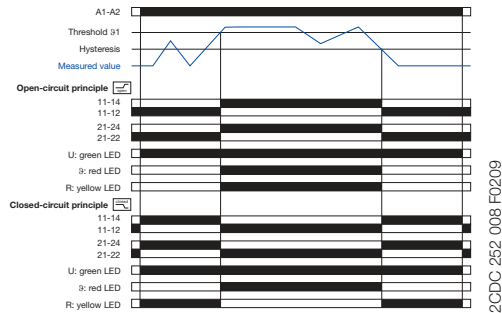

2CDC 252 008 F0209

#### CM-TCS - Undervoltage

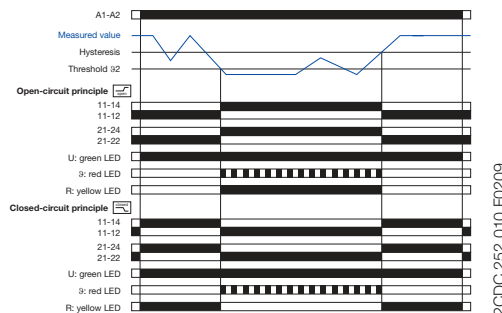

2CDC 252 010 F0209

#### CM-TCS - Temperature monitoring

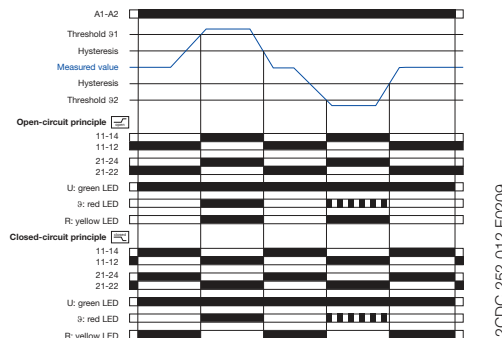

2CDC 252 012 F0209

	ON	OFF (default)
DIP switch 1 Monitoring principle	Overtemperature monitoring If overtemperature monitoring is selected, the CM-TCS recognizes temperatures above the selected threshold and trips the output relay according to the selected operating principle.	Undertemperature monitoring If undertemperature monitoring is selected, the CM-TCS recognizes temperatures below the selected threshold and trips the output relay according to the selected operating principle.
DIP switch 2 Temperature window monitoring	Temperature window monitoring activated If temperature window monitoring is selected, the CM-TCS monitors over- and undertemperature. If temperature window monitoring is activated, DIP switch 1 is disabled.	Temperature window monitoring de-activated Temperature window monitoring is de-selected.
DIP switch 3 Operating principle of the output relays	Closed-circuit principle If closed-circuit principle is selected, the output relays are energized. They de-energize if a fault is occurring.	Open-circuit principle If open-circuit principle is selected, the output relays are deenergized. They energize if a fault is occurring.
DIP switch 4 2 x 1 c/o contact, 1 x 2 c/o contacts	2 x 1 c/o (SPDT) contact If operating principle 2 x 1 c/o contact is selected, the output relay R1 (11-12/14) reacts to threshold value $t_1$ and the output relay R2 (21-22/24) reacts to threshold value $t_2$ .	1 x 2 c/o (SPDT) contacts If operating principle 1 x 2 c/o contacts is selected, both output relays R1 (11-12/14) and R2 (21-22/24) react synchronously to one threshold value. Overtemperature monitoring: Settings of the threshold value $t_2$ have no effect on the operation. Undertemperature monitoring: Settings of the threshold values $t_2$ have no effect on the operation.



# Temperature monitoring relays

## Overview, functional description and diagrams

### Functional description

#### Digital tripping devices

Once the temperature has reached the set threshold of  $\upsilon_1$ , output relay K1 changes its switching state after the set time delay  $t$  has elapsed (K2 reacts in the same way for  $\upsilon_2$ ).

2

### Characteristic curves of resistance sensors

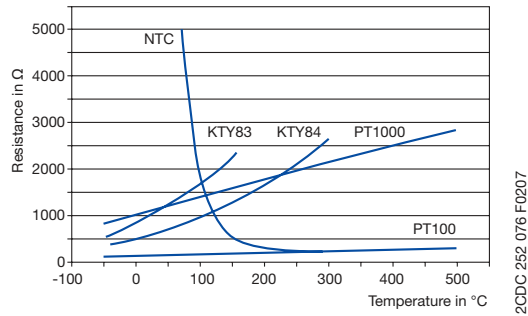

### Function diagrams

#### Overtemperature - C512/C513

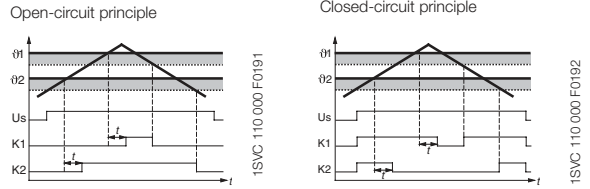

#### Undertemperature - C512/C513

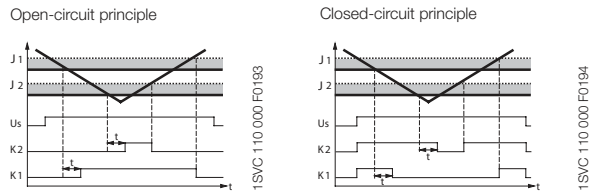

#### Range monitoring - C512/C513

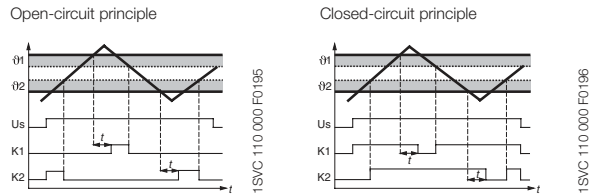

#### Function principle with storage function - C512/C513

using overtemperature with closed-circuit principle as an example

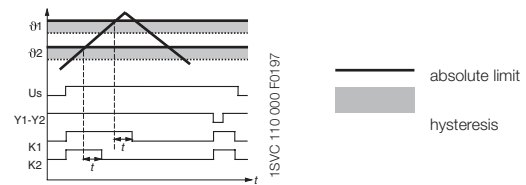

# Temperature monitoring relays

## Connection diagrams, Resistance thermometer sensors

### Connection diagrams

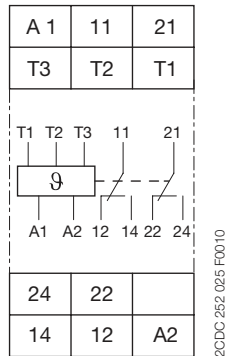

#### CM-TCS

A1-A2 Control supply voltage  
 11-12/14 Output relay R1  
 21-22/24 Output relay R2  
 T1, T2, T3 Measuring input, connection PT100

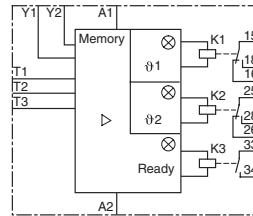

#### C512

A1-A2 Rated control supply voltage  
 15-16/18 Output contacts  
 25-26/28  
 33-34  
 T1-T3 Sensor connection  
 Y1-Y2 Connection for storage bridge

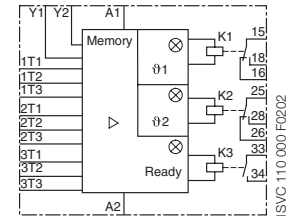

#### C513

A1-A2 Rated control supply voltage  
 15-16/18 Output contacts  
 25-26/28  
 33-34  
 1T1-1T3 Sensor connection 1  
 2T1-2T3 Sensor connection 2  
 3T1-3T3 Sensor connection 3  
 Y1-Y2 Connection for storage bridge

### Connection of resistance thermometer sensors

#### 2-wire measurement

When using 2-wire temperature sensors the sensor resistance and the wire resistance are added together.

The resulting systematic errors must be taken into account when adjusting the tripping device.

A jumper must be connected between the terminals T2 and T3.

The following table can be used for PT100 sensors to determine the temperature errors caused by the line length.

When using resistance sensors with two-wire connection a bridge must be inserted between terminals T2 and T3.

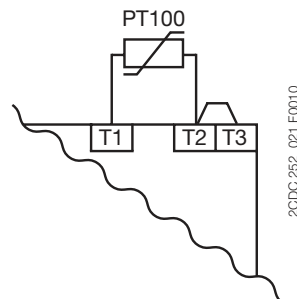

#### Error caused by the line

The error resulting from the line resistance amounts to approx. 2.5 Kelvin/Ohm. If the resistance of the line is not known and it is not possible to measure it, the error caused by the line can be estimated using the following table.

#### Temperature error

(depending on the line length and conductor cross section for PT100 sensors at an ambient temperature of 20 °C, in K)

Line length in m	Wire size mm <sup>2</sup>			
	0.50	0.75	1	1.5
0	0.0	0.0	0.0	0.0
10	1.8	1.2	0.9	0.6
25	4.5	3.0	2.3	1.5
50	9.0	6.0	4.5	3.0
75	13.6	9.0	6.8	4.5
100	18.1	12.1	9.0	6.0
200	36.3	24.2	18.1	12.1
500	91.6	60.8	45.5	30.2

#### 3-wire measurement

To minimize the influence of the wire resistance, a three-wire connection is usually used.

By means of the additional wire two measuring circuits are created. One of these two circuits is used for reference. This way, the tripping device can calculate and take into account the wire resistance automatically.

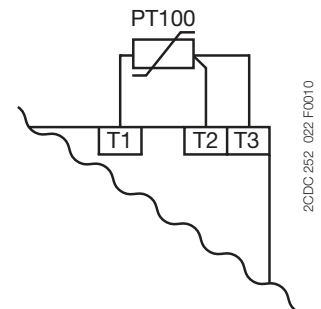

# Temperature monitoring relays

## Technical data

2

Type		CM-TCS.11/12/13 S/P <sup>1)</sup>	CM-TCS.21/22/23 S/P <sup>1)</sup>
<b>Input circuit</b>			
Rated control supply voltage U <sub>s</sub>	A1-A2	24-240 V AC/DC	24 V AC/DC
Rated control supply voltage U <sub>s</sub> tolerance		-15...+10 %	
Typical current / power / consumption	24 V DC	33 mA / 0.8 VA	18 mA / 0.45 VA
	115 V AC	12.5 mA / 1.5 VA	n/a
	230 V AC	13 mA / 2.9 VA	n/a
Rated frequency	AC	13.5-440 Hz	50/60 Hz
Frequency range	AC	13.5-440 Hz	45-65 Hz
Power failure buffering time	min.	20 ms	
<b>Measuring circuit</b>		<b>T1, T2, T3</b>	
Sensor type		PT100	
Connection of the sensor	2-wire	yes, jumper between T2-T3	
	3-wire	yes, use terminal T1, T2, T3	
Monitoring function		overtemperature, undertemperature or window monitoring	
Threshold values adjustable within the measuring range	CM-TCS.x1	-50...+50 °C	
	CM-TCS.x2	0...+100 °C	
	CM-TCS.x3	0...+200 °C	
Number of possible thresholds		2	
Tolerance of the adjusted threshold value		typ. ±5 % of the range end value	
Hysteresis related to the threshold value		2-20 % of threshold value, min. 1 °C	
Measuring principle		continuous current	
Typical current in the sensor circuit		0.8 mA	
Interrupted wire detection		yes, indicated via LED status	
Short-circuit detection		yes, indicated via LED status	
Accuracy within the rated control supply voltage tolerance		< 0.2 °C / or < 0.01 %/K	
Accuracy within the temperature range		< 0.2 °C / or < 0.01 %/K	
Repeat accuracy (constant parameters)		< 0.2 % of full scale	
Maximum measuring cycle		320 ms	
<b>Output circuit</b>			
Kind of output		2 x 1 or 1 x 2 c/o (SPDT) contacts configurable	
Operating principle <sup>1)</sup>		open- or closed-circuit principle configurable	
Contact material		AgNi alloy, Cd free	
Rated voltage (VDE 0110, IEC 60947-1)		250 V AC / 300 V DC	
Minimum switching voltage / Minimum switching current		24 V / 10 mA	
Maximum switching voltage / Maximum switching current		see 'Load limit curves'	
Rated operating current I <sub>b</sub> (IEC/EN 60947-1-5)	AC12 (resistive) 230 V	4 A	
	AC15 (inductive 230 V	3 A	
	DC12 (resistive) 24 V	4 A	
	DC13 (inductive) 24 V	2 A	
	utilization category	B 300, pilot duty general purpose (250 V, 4 A, cos φ 0.75)	
AC Rating (UL508)	maximum rated operational voltage	250 V AC	
	maximum continuous thermal current at B 300	4 A	
	maximum making/breaking apparent power at B 300	3600/360 VA	
Mechanical lifetime		30 x 10 <sup>6</sup> switching cycles	
Electrical lifetime ((AC12, 230 V, 4 A)		0.1 x 10 <sup>6</sup> switching cycles	
Maximum fuse rating to achieve short-circuit protection	n/c contact	6 A fast-acting	
	n/o contact	10 A fast-acting	
Conventional thermal current I <sub>th acc.</sub> IEC/EN 60947-1		4 A	
<b>General data</b>			
Dimensions (W x H x D)		22.5 x 78 x 100 mm (0.89 x 3.07 x 3.94 in)	
Mounting position		any	
Weight	net weight	0.141 kg (0.310 lb)	0.127 kg (0.281 lb)
	gross weight	0.166 kg (0.366 lb)	0.153 kg (0.367 lb)
	enclosure / terminals	IP50 / IP20	
Ambient temperature range	operation	-40...+60 °C	
	storage/transport	-40...+85 °C	
Mounting		DIN rail (IEC/EN 60715), snap-on mounting without any tool	
<b>General data for devices in new housing</b>			
Dimensions (W x H x D)		22.5 x 85.6 x 103.7 mm (0.89 x 3.37 x 4.08 in)	
Mounting position		any	
Weight	net weight	CM-TCS.1x	0.151 kg (0.333 lb)
		CM-TCS.2x	0.138 kg (0.304 lb)
	gross weight	CM-TCS.1x	0.176 kg (0.388 lb)
	CM-TCS.2x	0.163 kg (0.360 lb)	
Degree of protection	enclosure / terminals	IP50 / IP20	
Ambient temperature range	operation	-40...+60 °C	
	storage/transport	-40...+85 °C	
Mounting		DIN rail (IEC/EN 60715), snap-on mounting without any tool	

<sup>1)</sup> The products with old order codes (1SVR 6x0 xxx xxx) vary in different technical data. Please refer to page the old data sheet 2CDC 112 162 D0201.

# Temperature monitoring relays

## Technical data

Type		CM-TCS.11/12/13 <sup>1)</sup>	CM-TCS.21/22/23 <sup>1)</sup>
<b>Electrical connection</b>			
Wire size	rigid	2 x 0.5-4 mm <sup>2</sup> (2 x 20-12 AWG)	
	fine-strand with wire end ferrule	2 x 0.75-2.5 mm <sup>2</sup> (2 x 18-14 AWG)	
Stripping length		7 mm (0.28 in)	
Tightening torque		0.6-0.8 Nm (5.31-7.08 lb.in)	
<b>Electrical connection for devices in new housing</b>			
Wire size		<b>Screw connection technology</b>	<b>Easy Connect Technology (Push-in)</b>
	rigid	1 x 0.5-2.5 mm <sup>2</sup> (1 x 20-14 AWG) 2 x 0.5-1.5 mm <sup>2</sup> (2 x 20-16 AWG)	2 x 0.5-1.5 mm <sup>2</sup> (2 x 20-16 AWG)
	fine-strand with wire end ferrule	1 x 0.5-4 mm <sup>2</sup> (1 x 20-12 AWG) 2 x 0.5-2.5 mm <sup>2</sup> (2 x 20-14 AWG)	2 x 0.5-1.5 mm <sup>2</sup> (2 x 20-16 AWG)
Stripping length		8 mm (0.32 in)	
Tightening torque		0.6-0.8 Nm (5.31-7.08 lb.in)	-
<b>Standards</b>			
Product standard		IEC/EN 60255-6: 2008	
Other standards		EN 50178, IEC/EN 60204	
Low Voltage Directive		2006/95/EC	
EMC Directive		2004/108/EC	
RoHS Directive		2002/95/EC	
<b>Environmental data</b>			
Ambient temperature ranges	operation/storage/ transport	-40...+60°C/-40...+85°C/-40...+85°C	
Climatic category		3K5 (no condensation, no ice formation)	
Damp heat, cyclic		6 x 24 h cycle, 55 °C, 95 % RH	
Vibration, sinusoidal		Class 2	
Shock		Class 2	
<b>Isolation data</b>			
Rated impulse withstand voltage U <sub>imp</sub> between all isolated circuits (IEC/EN 60947-1, IEC/EN 60664-1, VDE 0110-1)	supply circuit / measuring circuit	4 kV	n/a
	supply circuit / output circuits	4 kV	
	measuring circuit / output circuits	4 kV	
	output circuit 1 / output circuit 2	4 kV	
Pollution degree (IEC/EN 60664-1, VDE 0110-1)		3	
Overvoltage category (IEC/EN 60664-1, VDE 0110-1)		III	
Rated insulation voltage U <sub>i</sub> (IEC/EN 60947-1, IEC/EN 60664-1, VDE 0110-1)	supply circuit / measuring circuit	300 V	n/a
	supply circuit / output circuits	300 V	
	measuring circuit / output circuits	300 V	
	output circuit 1 / output circuit 2	300 V	
Basis isolation for rated control supply voltage (IEC/EN 60664-1, VDE 0110-1)	supply circuit / measuring circuit	250 V AC / 300 V DC	n/a
	supply circuit / output circuits	250 V AC / 300 V DC	
	measuring circuit / output circuits	250 V AC / 300 V DC	
	output circuit 1 / output circuit 2	250 V AC / 300 V DC	
Protective separation (IEC/EN 61140, IEC/EN 50178)	supply circuit / measuring circuit	250 V AC / 250 V DC	n/a
	supply circuit / output circuits	250 V AC / 300 V DC	250 V AC / 250 V DC
	measuring circuit / output circuits	250 V AC / 300 V DC	250 V AC / 250 V DC
Test voltage between all isolated circuits, routine test (IEC/EN 60255-5, IEC/EN 61010-1)	supply circuit / measuring circuit	2.0 kV, 50 Hz, 1 s	-
	supply circuit / output circuits	2.0 kV, 50 Hz, 1 s	
	measuring circuit / output circuits	2.0 kV, 50 Hz, 1 s	
Test voltage between all isolated circuits, type test (IEC/EN 60255-5)	supply circuit / measuring circuit	4.0 kV, 50 Hz, 1 s	-
	supply circuit / output circuits	4.0 kV, 50 Hz, 1 s	
	measuring circuit / output circuits	4.0 kV, 50 Hz, 1 s	
<b>Electromagnetic compatibility</b>			
Interference immunity to			
electrostatic discharge	IEC/EN 61000-4-2	IEC/EN 61000-6-1, IEC/EN 61000-6-2, IEC/EN 61326-2-4	
radiated, radio-frequency, electromagnetic field	IEC/EN 61000-4-3	Level 3, 6 kV / 8 kV	
electrical fast transient/burst	IEC/EN 61000-4-4	Level 3, 10 V/m (1 GHz) / 3 V/m (2 GHz) / 1 V/m (2.7 GHz)	
surge	IEC/EN 61000-4-52	Level 3, 2 kV / 5 kVz	
conducted disturbances, induced by radio-frequency fields	IEC/EN 61000-4-6	Level 3, installation class 3, supply circuit and measuring circuit 1 kV L-L, 2 kV L-earth	
voltage dips, short interruptions and voltage variations	IEC/EN 61000-4-11	Level 3, 10 V	
harmonics and interharmonics	IEC/EN 61000-4-13	Level 3	
Interference emission			
high-frequency radiated	IEC/CISPR 22, EN 50022	EN 61000-6-3, EN 61000-6-4	
high-frequency conducted	IEC/CISPR 22, EN 50022	Class B	

<sup>1)</sup> The products with old order codes (1SVR 6x0 xxx xxx) vary in different technical data. Please refer to page the old data sheet 2CDC 112 162 D0201.

# Temperature monitoring relays

## Technical data

2

Type		C512	C513
<b>Input circuit</b>			
Rated control supply voltage $U_s$	A1-A2	24 V AC/DC	-
Power consumption	A1-A2	24-240 V AC/DC	
	AC	< 7 VA	
	DC	< 4 W	
Rated control supply voltage $U_s$ tolerance		-15...+10 %	
Rated frequency	AC		
<b>Sensor circuit</b>			
Sensor type		PT100, PT1000, KTY83, KTY84, NTC	
Sensor current	PT100	typ. 1 mA	
	PT1000, KTY83, KTY84, NTC	typ. 0.2 mA	
Wire-break detection		yes (not for NTC)	
Short-circuit detection		yes	
3-wire connection		yes (2-wire connection of sensors with terminals T2 and T3 bridged)	
<b>Measuring circuit</b>			
Setting accuracy at $T_a = 20\text{ °C}$ ( $T_{20}$ )		< $\pm 2\text{ K} \pm 1\text{ digit}$	
Accuracy within the temperature range		0.05 °C / °C deviation from $T_{20}$	
Response time		500 ms	
Hysteresis settings	temperature 1	1-99 kelvin	
	temperature 2	1-99 kelvin	
Tripping delay		0-999 s	
<b>Output circuit</b>			
Kind of output		2 c/o + 1n/o	2 c/o + 1 n/o
Rated operating current $I_o$ (IEC/EN 60947-1-5)	AC12 (resistive) 230 V	n/a	
	AC15 (inductive) 230 V	3 A	
	DC12 (resistive) 24 V	1 A	
	DC13 (inductive) 24 V	0.1 A	
Mechanical lifetime		30 x 10 <sup>6</sup> switching cycles	
Electrical lifetime (AC15 at 3 A)		0.1 x 10 <sup>5</sup> switching cycles	
Max. fuse rating to achieve short-circuit protection		4 A, operating class gL/gG	
<b>General data</b>			
Dimensions (W x H x D)		45 x 105.9 x 86 mm (1.77 x 4.17 x 3.39 in)	
Tightening torque		0.8-1.2 Nm	
Mounting position		any	
Degree of protection	enclosure / terminals	IP 40 / IP 20	
Ambient temperature range	operation	-25...+60 °C	
	storage	-40...+80 °C	
Mounting		DIN rail (IEC/EN 60715)	
<b>Electrical connection</b>			
Wire size	rigid	1 x 4 mm <sup>2</sup> (1 x 12 AWG), 2 x 2.5 mm <sup>2</sup> (2 x 14 AWG)	
	fine-strand with wire end ferrule	1 x 2.5 mm <sup>2</sup> (1 x 14 AWG), 2 x 1.5 mm <sup>2</sup> (2 x 16 AWG)	
<b>Standards</b>			
Environmental conditions		IEC 60721-3-3	
Low Voltage Directive		IEC 60947-5-1, VDE 0660	
Electromagnetic compatibility	Interference immunity	EN 61000-6-2	
	Interference emission	EN 61000-6-4	
Vibration resistance (IEC 68-2-6)		5-26 Hz / 0.75 mm	
Shock resistance (IEC 68-2-27)		15 g / 11 ms	
<b>Isolation data</b>			
Rated insulation voltage		300 V AC	
Pollution degree		3	



# Liquid level monitors and controls

## Product group picture

2



# Liquid level monitors and controls

## Table of contents

---

<b>Liquid level monitors and controls</b>	
Product group picture	2/103
Table of contents	2/104
Benefits and advantages	2/105
Ordering details	2/106
Ordering details - Accessories	2/107
Function diagrams	2/108
Connection diagrams	2/110
Application examples	2/111
Technical data	2/113
Notes	2/116



# Liquid level monitors and controls

## Benefits and advantages

2

### CM-ENE MIN/MAX

- Monitoring of pump systems for dry running (ENE MIN) and overflow (ENE MAX)
- Connection of 2 electrodes possible at C and MIN/MAX
- 3 supply voltage versions
- Optimal price/performance ratio
- 1 n/o contact: Open-circuit principle for CM-ENE MIN, Closed-circuit principle for CM-ENE MAX
- LED for status indication

### CM-ENS

- Monitoring and control of liquid levels (when draining or filling liquids in tanks)
- Monitoring and control of mixture ratios (conductivity of liquids)
- Adjustable response sensitivity 5-100 k $\Omega$
- 4 supply voltage versions 24 - 415 V AC
- Version with protective separation acc. to VDE 0160 
- Cascadable
- 1 c/o contact or 1 n/o and 1 n/c contact
- 2 LEDs for status indication

### CM-ENS UP/DOWN

- Monitoring and control of liquid levels
- Selectable function "fill" or "drain"
- Adjustable response sensitivity 5-100 k $\Omega$
- Cascadable
- 1 c/o contact
- 2 LEDs for status indication

### CM-ENN

- Monitoring and control of liquid levels (when emptying or filling liquids in tanks)
- Monitoring and control of mixture ratios (conductivity of liquids)
- 3 response sensitivities from 250  $\Omega$  - 500 k $\Omega$  in one unit
- 5 supply voltage versions 24 V AC/DC - 415 V AC
- Selectable ON- or OFF-delay 0.1-10 s
- 2 c/o contacts
- 2 LEDs for status indication

### CM-ENN UP/DOWN

- Liquid level relay with 5 electrode inputs
- Level control with integrated overflow and dry-running protection
- Adjustable response sensitivity 5-100 k $\Omega$
- Cascadable
- 1 c/o contact and 2 n/c contacts as alarm outputs
- 4 LEDs for status indication

Response sensitivity	Max. electrode current	Max. cable capacity	Max. cable length
250 $\Omega$ - 5 k $\Omega$	8 mA	200 nF	1000 m
2.5-50 k $\Omega$	2 mA	20 nF	100 m
25-500 k $\Omega$	0.5 mA	4 nF	20 m

# Liquid level monitors and controls

## Ordering details



1SVR550851R9500

CM-ENE MIN



1SVR550851R9400

CM-ENE MAX

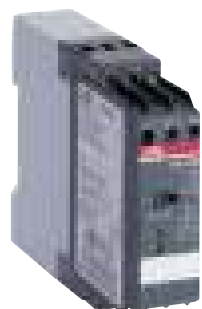

1SVR430851R1100

CM-ENS



1SVR450051R0000

CM-ENN

### Description

ABB's liquid level monitoring relays for regulation and control of liquid levels and ratios of mixtures of conductive fluids.

The assortment includes single function and multifunction monitoring relays which can be used for over flow and dry-running protection, for filling and draining applications, for max and min alarm or any combination of such functions. Furthermore a wide range of accessories is available

### Ordering details

Rated control supply voltage	Type	Order code	Price 1 pce	Weight (1 pce) kg (lb)
24 V AC	CM-ENE MIN	1SVR550855R9500		0.15 (0.33)
110-130 V AC		1SVR550850R9500		0.15 (0.33)
220-240 V AC		1SVR550851R9500		0.15 (0.33)
24 V AC	CM-ENE MAX	1SVR550855R9400		0.15 (0.33)
110-130 V AC		1SVR550850R9400		0.15 (0.33)
220-240 V AC		1SVR550851R9400		0.15 (0.33)
24 V AC	CM-ENS	1SVR430851R9100		0.15 (0.33)
110-130 V AC		1SVR430851R0100		0.15 (0.33)
220-240 V AC		1SVR430851R1100		0.15 (0.33)
380-415 V AC		1SVR430851R2100		0.15 (0.33)
220-240 V AC <sup>1)</sup>		1SVR430851R1300		0.15 (0.33)
24 V AC		1SVR430851R9200		0.15 (0.33)
110-130 V AC	CM-ENS UP/DOWN	1SVR430851R0200		0.15 (0.33)
220-240 V AC		1SVR430851R1200		0.15 (0.33)
24-240 V AC/DC	CM-ENN	1SVR450055R0000		0.30 (0.66)
24 V AC		1SVR450059R0000		0.30 (0.66)
110-130 V AC		1SVR450050R0000		0.30 (0.66)
220-240 V AC		1SVR450051R0000		0.30 (0.66)
380-415 V AC		1SVR450052R0000		0.30 (0.66)
24 V AC		1SVR450059R0100		0.15 (0.33)
110-130 V AC	CM-ENN UP/DOWN	1SVR450050R0100		0.15 (0.33)
220-240 V AC		1SVR450051R0100		0.15 (0.33)
380-415 V AC		1SVR450052R0100		0.15 (0.33)

<sup>1)</sup> Version with protective separation acc. to VDE 0160, 1 n/o, 1 n/c

### Liquid level monitors are

Suitable for		Not suitable for	
spring water	acids, bases	chemically pure water	ethylene glycol
drinking water	liquid fertilizers	fuel	concentrated alcohol
sea water	milk, beer, coffee	oils	paraffin
sewage	non-concentrated alcohol	explosive areas (liquid gas)	lacquers

# Liquid level monitors and controls

## Ordering details - Accessories

2

### Compact support CM-KH-3 for 3 bar electrodes

Dimensions in mm

- Ideally suited for use with liquid level relays CM-ENS and CM-ENN
- Wire connection by screw terminals
- Pull relief by M16 screwed cable glands
- Temperature range up to 90 °C
- Food safe material (PPH)
- Screw-in electrodes (M4 thread)
- Distance plate (CM-AH-3) and locking nut (CM-GM-1) optionally available as an accessory

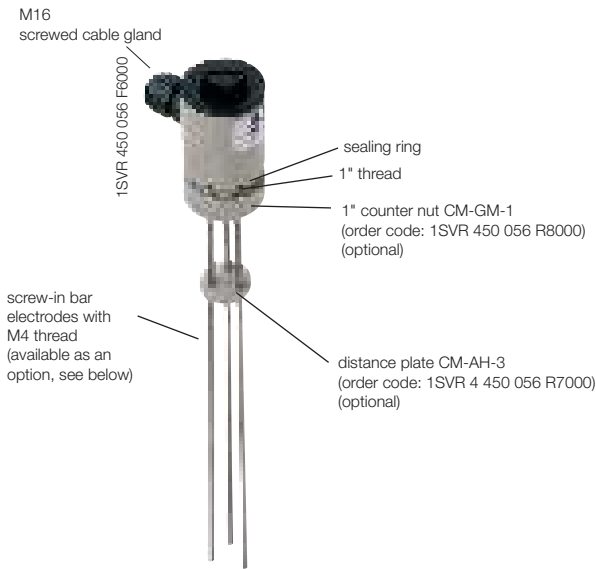

### Compact support CM-KH-3

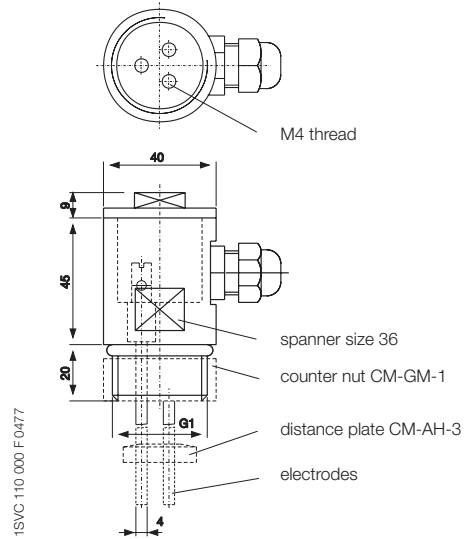

### Distance plate CM-AH-3

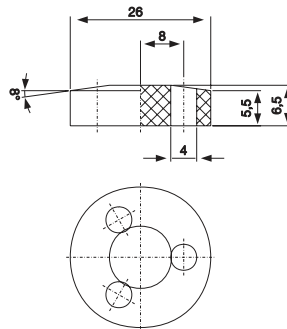

### Counter nut CM-GM-1

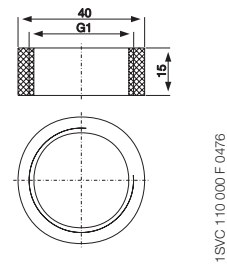

### Technical data compact support

Type of mounting:	G 1" thread
Mounting position:	any
Enclosure material:	PPH
Sealing:	NBR 70
Temperature range:	90 °C max.
Pressure:	10 bar max. (60 °C)

Description	Type	Order code	Price	Pkg qty	Weight (1 pce) kg (lb)
Compact support for 3 bar electrodes	CM-KH-3	1SVR450056R6000			0.06 (0.132)
Distance plate for 3 bar electrodes	CM-AH-3	1SVR450056R7000		1	0.06 (0.132)
Counter nut for 1" thread	CM-GM-1	1SVR450056R8000			0.06 (0.132)

### Screw-in bar electrodes for compact support CM-KH-3

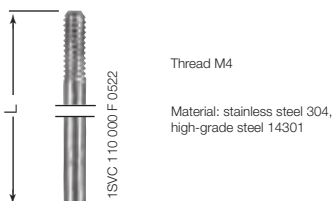

### Suspension electrode CM-HE

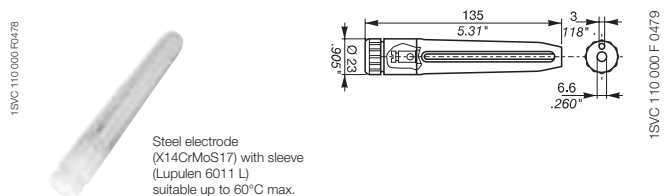

During project engineering the compatibility of the electrode material with the medium to be supervised is to be examined!

Lenght	Type	Order code	Price	Pkg qty	Weight (1 pce) kg (lb)
300 mm	CM-SE-300	1SVR450056R0000			0.08 (0.176)
600 mm	CM-SE-600	1SVR450056R0100			0.08 (0.176)
1000 mm	CM-SE-1000	1SVR450056R0200		1	0.08 (0.176)
CM-HE	CM-HE	1SVR402902R0000			0.08 (0.176)

# Liquid level monitors and controls

## Function diagrams

### Function diagram CM-ENS

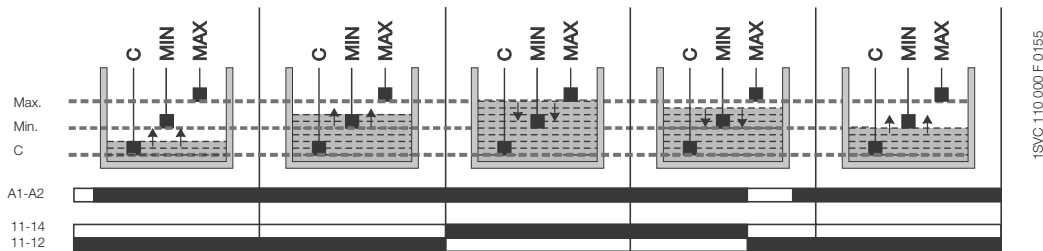

The CM-ENS monitors levels of conductive liquids and is used for example for liquid level control in pump systems. It can be used for filling or draining tanks for example. It is also suitable for monitoring the conductivity of liquids. The measuring principle is based on the resistance change sensed by single-pole electrodes. After the supply voltage is applied to the terminals A1 and A2, the output relay is de-energized. The probes must be connected to C, MAX, MIN. The output relay energizes if the liquid exceeds the maximum level (C and MAX wet) and de-energizes if the liquid level is below the minimum level (MAX and MIN dry). Based on the measuring circuit there will be a response delay of approx. 250 ms at maximum sensitivity. Different levels in one tank can be controlled by up to 5 CM-ENS without interfering with each other.

### Function diagram CM-ENN UP/DOWN

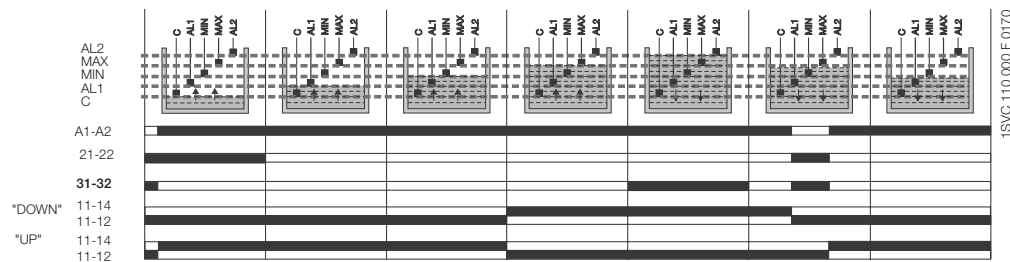

If a metal tank is used, the ground reference electrode C is not required. In this case the cable can be connected directly to the metal surface of the tank.

The CM-ENN UP/DOWN monitors levels of conductive liquids and media and is used e.g. for liquid level control in pump systems. The measuring principle is based on the resistance change sensed by single-pole electrodes. The function of the output relay 11-12/14 can be selected by a selector switch on the front of the unit to fill "UP" or drain "DOWN". If the "UP" function is selected, the output relay is energized until the MAX electrode becomes wet. Then it is de-energized and not re-energized until the MIN electrode becomes dry. If the "DOWN" function is selected, the output relay is energized as soon as the MAX electrode becomes wet. It remains energized until the liquid level has dropped below the MIN electrode. The electrode inputs AL1 and AL2 energize/de-energize the corresponding output relays RAL1 (21-22) and RAL2 (31-32). AL1 opens if contact RAL1 (21-22) is wet. AL2 closes if contact RAL2 (31-32) is wet. This way, two additional alarm outputs for exceeding or dropping below the normal level can be implemented in addition to the filling levels MAX and MIN.

### Function diagram CM-ENS UP/DOWN

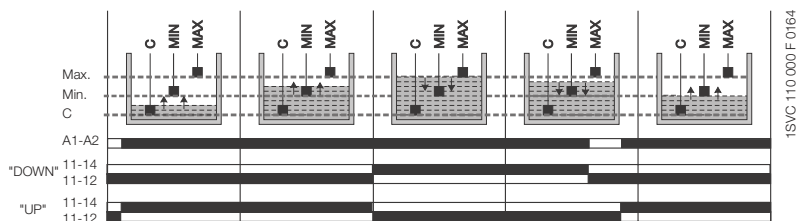

The CM-ENS UP/DOWN monitors levels of conductive liquids and other media, and is used e.g. for liquid level control in pump systems.

The measuring principle is based on the resistance change sensed by single-pole electrodes. The output relay functions fill (UP) or drain (DOWN) can be selected on a front-face selector switch. If the "UP" function is selected, the output relay is energized until the MAX electrode becomes wet. Then it is de-energized and not re-energized until the MIN electrode becomes dry. If the "DOWN" function is selected, the output relay is energized as soon as the MAX electrode becomes wet. It remains energized until the liquid level has dropped below the MIN electrode. The electrodes can be connected to more than one CM-ENS unit without interference.

# Liquid level monitors and controls

## Function diagrams

2

### Function diagrams CM-ENN

Circuit with 2 electrodes

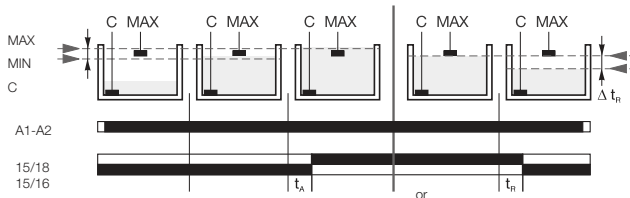

1SVC 110 000 F 0167

Circuit with 3 electrodes

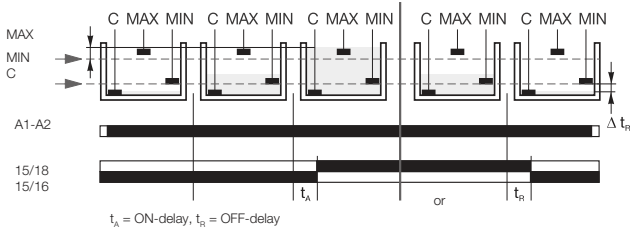

1SVC 110 000 F 0168

The CM-ENN monitors levels of conductive liquids and is used for example for liquid level monitoring in pump control systems, for dry-running protection of submersible pumps or overflow monitoring of tanks. It is also suitable for conductivity monitoring of liquids. The measuring principle is based on the resistance change sensed by single-pole electrodes (wet or dry). Instead of electrodes, other sensors or transducers can also be used if their output quantities are different resistance values. The measuring, output and supply circuits are electrically isolated for potential separation and to prevent electrical interference. Due to the integrated ON- or OFF-delay, it is possible to set up time-dependent liquid controls using only two electrodes (C, MAX). Different liquid levels in one tank can be controlled by up to 5 CM-ENN (AC version) without mutual interference.

### Function diagram CM-ENE MIN

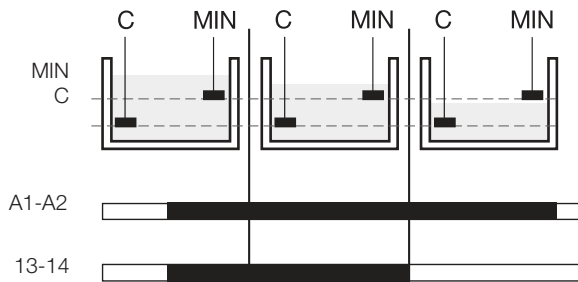

1SVC 110 000 F 0151

The liquid level relays CM-ENE MIN and CM-ENE MAX are used to monitor levels of conductive liquids, for example in pump control systems for dry-running or overflow monitoring. The measuring principle is based on the occurring resistance change when moistening single-pole electrodes. The single-pole electrodes (see also section Accessories) are connected to the terminals C and MIN or MAX. If the supply voltage is applied to A1-A2 and the electrodes are wet, the output relay of the CM-ENE MIN is energized and the output relay of the CM-ENE MAX is de-energized. The output relay of the CM-ENE MIN de-energizes if the electrodes are no longer wet. The output relay of the CM-ENE MAX energizes if the electrodes are no longer wet.

### Function diagram CM-ENE MAX

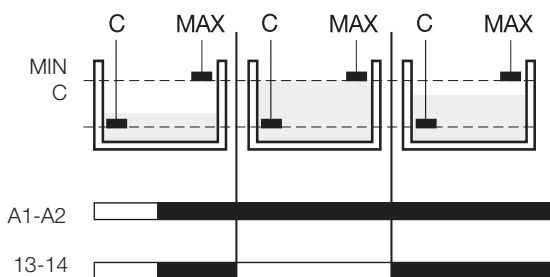

1SVC 110 000 F 0152

# Liquid level monitors and controls

## Connection diagrams

Connection diagram CM-ENE MIN

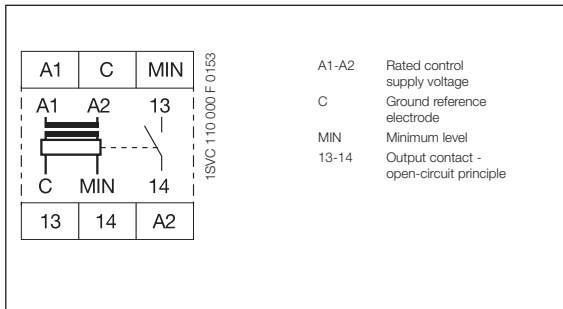

Connection diagram CM-ENE MAX

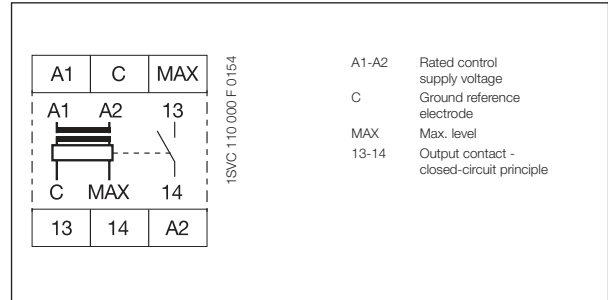

Connection diagram CM-ENS

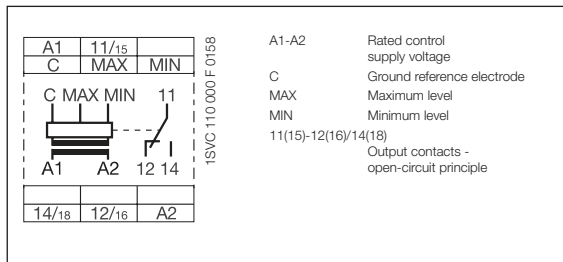

Connection diagram CM-ENN

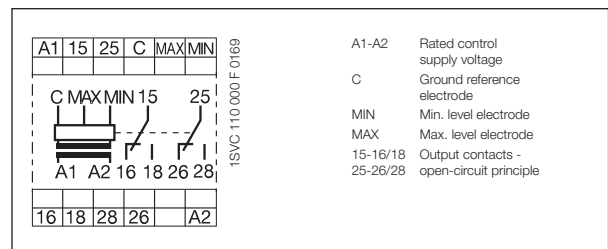

Connection diagram CM-ENS UP/DOWN

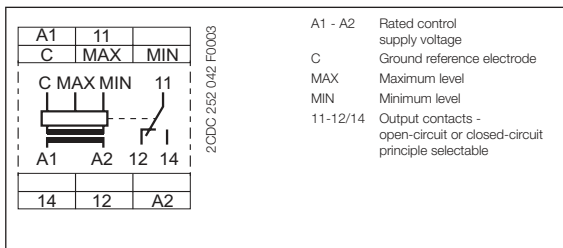

Connection diagram CM-ENN UP/DOWN

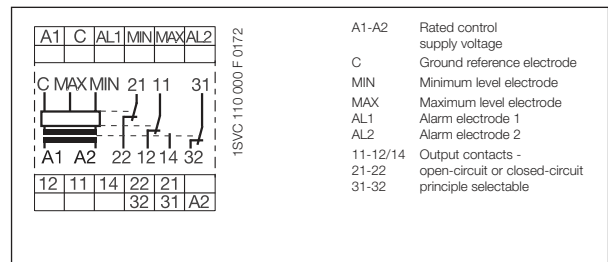

# Liquid level monitors and controls

## Application examples

### Application examples CM-ENE MIN/MAX

CM-ENE MIN

CM-ENE MAX

CM-ENE MIN und CM-ENE MAX

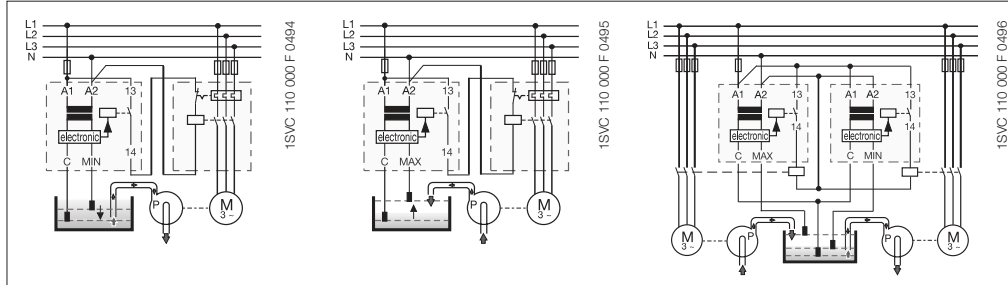

### Application examples CM-ENS

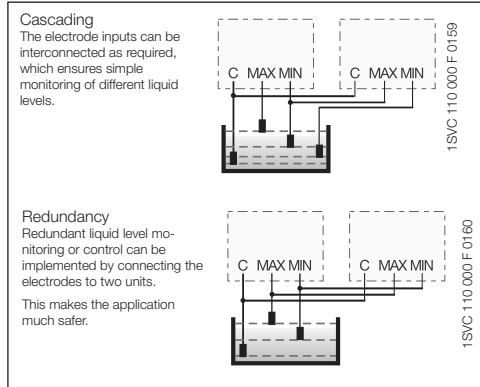
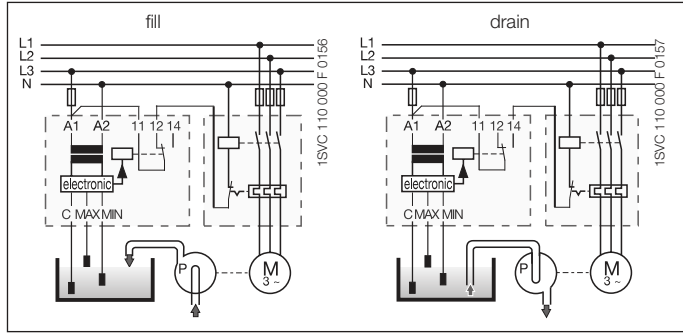

### Application examples CM-ENS UP/DOWN

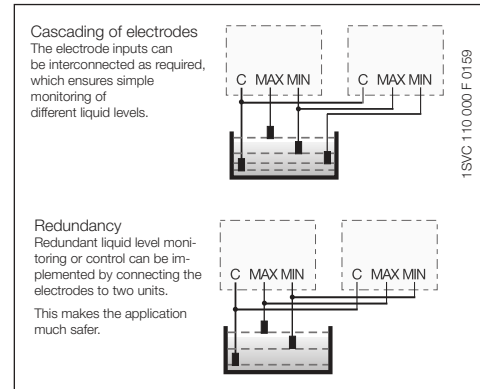
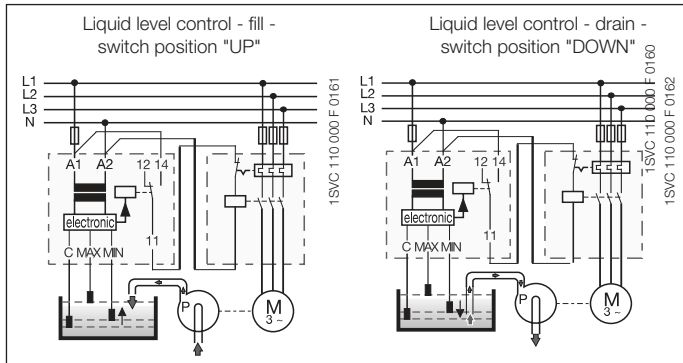

# Liquid level monitors and controls

## Application examples

### Application examples CM-ENN

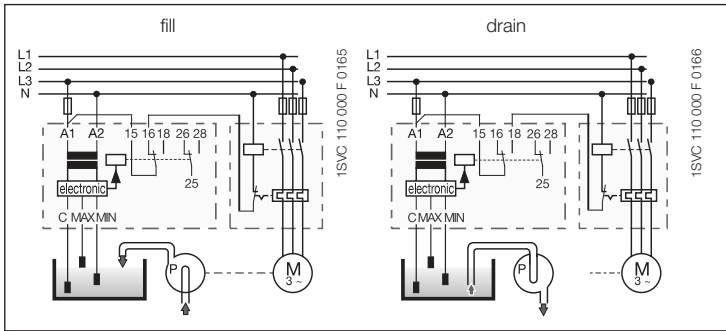

For commissioning, set both potentiometers (response sensitivity = R value and ON-delay = time value) to the minimum value (5) and select a suitable resistance range (sector). After all electrodes have been wetted by the liquid being monitored, turn the sensitivity potentiometer towards maximum value (100) until the relay energizes. If the relay does not energize, select a higher  $\Omega$  value (sector) on the device and proceed as before. Then it has to be checked if the relay de-energizes properly as soon as the electrodes C and MIN are no longer wet. Liquid levels higher than the maximum level electrode can be obtained by setting an ON-delay (TA = 0.1...10 s).

Liquid levels lower than the minimum level electrode can be obtained by setting an OFF-delay time (TR = 0.1...10 s), e.g. for emptying tanks.

### Application example CM-ENN UP/DOWN

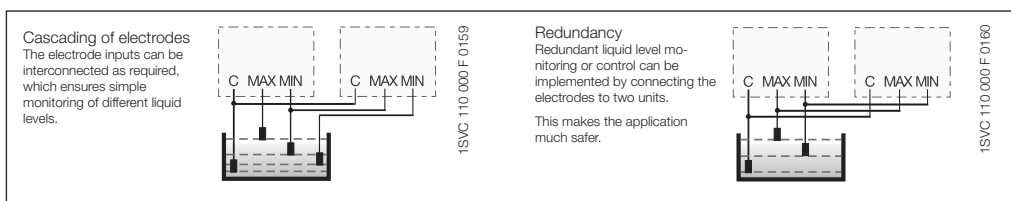
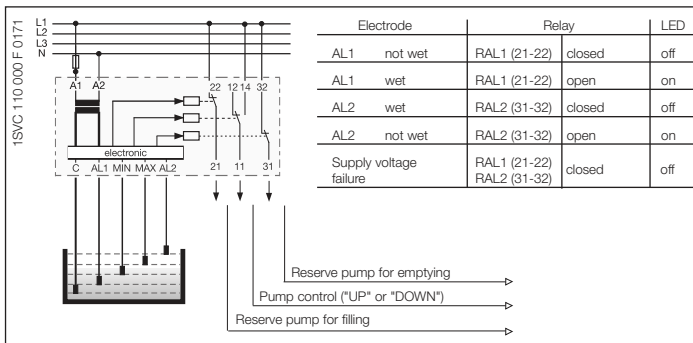



# Liquid level monitors and controls

## Technical data

2

Type		CM-ENE MIN	CM-ENE MAX
<b>Supply circuit</b>			
Rated control supply voltage $U_s$ - power consumption	A1-A2	24 V AC	approx. 1.5 VA
	A1-A2	110-130 V AC	approx. 1.2 VA
	A1-A2	220-240 V AC	approx. 1.4 VA
Rated control supply voltage $U_s$ tolerance		-15...+15 %	
Rated frequency		50-60 Hz	
Duty time		100 %	
<b>Measuring circuit</b>		<b>MIN-C, MAX-C</b>	
Monitoring function		dry-running protection	overflow protection
Response sensitivity		0-100 k $\Omega$ , not adjustable	
Maximum electrode voltage		30 V AC	
Maximum electrode current		1.5 mA	
Electrode supply line	max. cable capacity	3 nF	
	max. cable length	30 m	
<b>Timing circuit</b>			
Time delay		-	
Tripping delay		fixed approx. 200 ms	
<b>Indication of operational states</b>			
Output relay energized		R: yellow LED	
<b>Output circuits</b>		<b>13-14</b>	
Kind of output		1 n/o contact	
Operational principle <sup>1)</sup>		open-circuit principle	closed-circuit principle
Contact material		AgCdo	
Rated operational voltage $U_o$ (IEC/EN 60947-1)		250 V	
Minimum switching voltage / minimum switching current		- / -	
Maximum switching voltage		250 V	
Rated operational current $I_o$ (IEC/EN 60947-5-1)	AC12 (resistive) 230 V	4 A	
	AC15 (inductive) 230 V	3 A	
	DC12 (resistive) 24 V	4 A	
	DC13 (inductive) 24 V	2 A	
AC rating (UL 508)	Utilization category (Control Circuit Rating Code)	B 300	
	max. rated operational voltage	300 V AC	
	max. continuous thermal current at B 300	5 A	
	max. making/breaking apparent power at B 300	3600/360 VA	
Mechanical lifetime		30 x 10 <sup>6</sup> switching cycles	
Electrical lifetime (AC12, 230 V, 4 A)		0.3 x 10 <sup>6</sup> switching cycles	
Max. fuse rating to achieve short-circuit protection	n/c contact	-	
	n/o contact	10 A fast-acting	
<b>General data</b>			
Dimensions (W x H x D)		22.5 x 78 x 78.5 mm (0.89 x 3.07 x 3.09 in)	
Mounting position		any	
Degree of protection	enclosure / terminals	IP50 / IP20	
Ambient temperature range	operation / storage	-20...+60 °C / -40...+85 °C	
Mounting		DIN rail (IEC/EN 60715)	
<b>Electrical connection</b>			
Wire size	fine-strand with wire-end ferrule	2 x 0.75-1.5 mm <sup>2</sup> (2 x 18-16 AWG)	
	fine-strand without wire-end ferrule	2 x 1-1.5 mm <sup>2</sup> (2 x 18-16 AWG)	
	rigid	2 x 0.75-1.5 mm <sup>2</sup> (2 x 18-16 AWG)	
Stripping length		10 mm (0.39 inch)	
Tightening torque		0.6-0.8 Nm	
<b>Standards</b>			
Product standard		IEC 255-6, EN 60255-6	
Low Voltage Directive		2006/95/EC	
EMC Directive		2004/108/EC	
<b>Electromagnetic compatibility</b>		<b>EN 61000-6-2, EN 61000-6-4</b>	
electrostatic discharge	IEC/EN 61000-4-2	Level 3 (6 kV / 8 kV)	
radiated, radio-frequency, electromagnetic field	IEC/EN 61000-4-3	Level 3 (10 V/m)	
electrical fast transient / burst	IEC/EN 61000-4-4	Level 3 (2 kV / 5 kHz)	
surge	IEC/EN 61000-4-5	Level 4 (2 kV L-L)	
conducted disturbances, induced by radio-frequency fields	IEC/EN 61000-4-6	Level 3 (10 V)	
Resistance to vibration (IEC 68-2-6)		6 g	
Mechanical resistance (IEC 68-2-6)		10 g	
<b>Isolation data</b>			
Rat. insulation volt. betw. supply, meas. & output circuit (VDE 0110, IEC 60947)		250 V	
Rated impulse withstand voltage between all isolated circuits (VDE 0110, IEC 664)		4 kV / 1.2-50 $\mu$ s	
Test voltage between all isolated circuits		2.5 kV, 50 Hz, 1 min.	
Pollution category (VDE 0110, IEC 664, IEC 255-5)		3 / C	
Overvoltage category (VDE 0110, IEC 664, IEC 255-5)		III / C	
Environmental testing (IEC 68-2-30)		24 h cycle time, 55 °C, 93 % rel., 96 h	

<sup>1)</sup> Open-circuit principle: Output relay energizes if the measured value exceeds/drops below the adjusted threshold.

Closed-circuit principle: Output relay de-energizes if the measured value exceeds/drops below the adjusted threshold.

# Liquid level monitors and controls

## Technical data

Type		CM-ENS	CM ENS UP/DOWN
<b>Supply circuit</b>			
Rated control supply voltage $U_s$ - power consumption	A1-A2	24 V AC	24 V AC
	A1-A2	110-130 V AC approx. 1.5 VA	110-130 V AC approx. 4 VA
	A1-A2	220-240 V AC approx. 1.5 VA	220-240 V AC approx. 4 VA
	A1-A2	380-415 V AC approx. 1.5 VA	
Rated control supply voltage $U_s$ tolerance		-15...+10 %	
Rated frequency		50-60 Hz	
Duty time		100 %	
<b>Measuring circuit</b>		<b>MAX-MIN-C</b>	
Monitoring function		liquid level control	
Response sensitivity		5-100 k $\Omega$ , adjustable	
Maximum electrode voltage		30 V AC	
Maximum electrode current		1 mA	
Electrode supply line	max. cable capacity	10 nF	
	max. cable length	100 m	
<b>Timing circuit</b>			
Time delay		-	
Tripping delay		approx. 250 ms	
<b>Indication of operational states</b>			
Control supply voltage		U: green LED	
Output relay energized		R MAX/MIN: yellow LED	
Alarm relay AL1			R AL1: yellow LED
Alarm relay AL2			R AL2: yellow LED
<b>Output circuits</b>		<b>11-12/14, 21-22, 31-32</b>	
Kind of output		1 c/o contact, 1 n/o + 1 n/c contact <sup>2)</sup>	
Operational principle <sup>1)</sup>		open-circuit principle	open- and closed-circuit principle
Contact material		AgCdo	
Rated operational voltage $U_e$ (IEC/EN 60947-1)		250 V	
Minimum switching voltage / minimum switching current		- / -	
Maximum switching voltage		250 V	
Rated operational current $I_e$ (IEC/EN 60947-5-1)	AC12 (resistive) 230 V	4 A	
	AC15 (inductive) 230 V	3 A	
	DC12 (resistive) 24 V	4 A	
	DC13 (inductive) 24 V	2 A	
	AC rating (UL 508)	Utilization category (Control Circuit Rating Code)	B 300
	max. rated operational voltage	300 V AC	
	max. continuous thermal current at B 300	5 A	
	max. making/breaking apparent power at B 300	3600/360 VA	
Mechanical lifetime		30 x 10 <sup>6</sup> switching cycles	
Electrical lifetime (AC12, 230 V, 4 A)		0.3 x 10 <sup>6</sup> switching cycles	
Max. fuse rating to achieve short-circuit protection	n/c / n/o contact		10 A fast-acting / 10 A fast-acting
<b>General data</b>			
Dimensions (W x H x D)		22.5 x 70 x 100 mm (0.89 x 3.07 x 3.94 in)	
Mounting position		any	
Degree of protection	enclosure / terminals	IP50 / IP20	
Ambient temperature range	operation / storage	-20...+60 °C / -40...+85 °C	
Mounting		DIN rail (IEC/EN 60715)	
<b>Electrical connection</b>			
Wire size	fine-strand with wire end ferrule	2 x 2.5 mm <sup>2</sup> (2 x 14 AWG)	
Standards			
Product standard		IEC 255-6, EN 60255-6	
Low Voltage Directive		2006/95/EG	
EMC Directive		2004/108/EG	
<b>Electromagnetic compatibility</b>			
electrostatic discharge	IEC/EN 61000-4-2	Level 3 (6 kV / 8kV)	
radiated, radio-frequency, electromagnetic field	IEC/EN 61000-4-3	Level 3 (10 V/m)	
electrical fast transient / burst	IEC/EN 61000-4-4	Level 3 (2 kV / 5 kHz)	
surge	IEC/EN 61000-4-5	Level 4 (2 kV L-L)	
conducted disturbances, induced by radio-frequency fields	IEC/EN 61000-4-6	Level 3 (10 V)	
Resistance to vibration (IEC 68-2-6)		4 g	
Mechanical resistance (IEC 68-2-6)		6 g	
<b>Isolation data</b>			
Rated insulation voltage between supply, measuring and output circuit (VDE 0110, IEC 60947)		250 V	
Rated impulse withstand voltage between all isolated circuits (VDE 0110, IEC 664)		4 kV / 1.2 - 50 $\mu$ s	
Test voltage between all isolated circuits		2.5 kV, 50 Hz, 1 min.	
Pollution category (VDE 0110, IEC 664, IEC 255-5)		3 / C	
Overvoltage category (VDE 0110, IEC 664, IEC 255-5)		III / C	
Environmental testing (IEC 68-2-30)		24 h cycle time, 55 °C, 93 % rel., 96 h	

<sup>1)</sup> Open-circuit principle: Output relay energizes if the measured value exceeds/drops below the adjusted threshold.  
 Closed-circuit principle: Output relay de-energizes if the measured value exceeds/drops below the adjusted threshold.

<sup>2)</sup> 1SVR 430 851 R1300 (version with safe isolation)

# Liquid level monitors and controls

## Technical data

2

Type		CM-ENN UP/DOWN	CM-ENN		
<b>Supply circuit</b>					
Rated control supply voltage $U_s$ - power consumption	A1-A2	24 V AC	24 V AC		
	A1-A2	110-130 V AC approx. 1.5 VA	110-130 V AC approx. 2.5 VA		
	A1-A2	220-240 V AC approx. 1.5 VA	220-240 V AC approx. 3 VA		
	A1-A2	380-415 V AC approx. 1.5 VA	380-415 V AC approx. 4 VA		
	A1-A2		24-240 V AC/DC approx. 2 VA/W		
Rated control supply voltage $U_s$ tolerance		-15...+10 %			
Rated frequency		50-60 Hz	50-60 Hz oder DC		
Duty time		100 %			
<b>Measuring circuit</b>					
<b>MAX-MIN-C</b>					
Monitoring function		liquid level control			
Response sensitivity		adjustable	adjustable		
		5-100 k $\Omega$	250 $\Omega$ - 5 k $\Omega$	2.5-50 k $\Omega$	25-500 k $\Omega$
Maximum electrode voltage		30 V AC	20 V AC		
Maximum electrode current		1 mA	8 mA	2 mA	0.5 mA
Electrode supply line	max. cable capacity	10 nF	200 nF	20 nF	4 nF
	max. cable length	100 m	1000 m	100 m	20 m
<b>Timing circuit</b>					
Time delay		-	0.1-10 s, adjustable, ON- or OFF-delay		
Tripping delay		approx. 250 ms	-		
<b>Indication of operational states</b>					
Control supply voltage		U: green LED			
Output relay energized		R MAX/MIN: yellow LED	R: yellow LED		
<b>Output circuits</b>					
Kind of output		<b>11-12/14, 21-22, 31-32</b>	<b>15-16/18, 25-26/28</b>		
Operational principle <sup>1)</sup>		1 c/o + 2 n/c contacts	2 c/o contacts		
Contact material		open-circuit principle	open- and closed-circuit principle		
Rated operational voltage $U_o$	IEC/EN 60947-1	250 V	400 V		
Minimum switching voltage / minimum switching current		- / -			
Maximum switching voltage		250 V	400 V		
Rated operational current $I_o$	AC12 (resistive) 230 V	4 A	5 A		
(IEC/EN 60947-5-1)	AC15 (inductive) 230 V	3 A			
	DC12 (resistive) 24 V	4 A	5 A		
	DC13 (inductive) 24 V	2 A	2.5 A		
AC rating (UL 508)	Utilization category (Control Circuit Rating Code)	B 300			
	max. rated operational voltage	300 V AC			
	max. continuous thermal current at B 300	5 A			
	max. making/breaking apparent power at B 300	3600/360 VA			
Mechanical lifetime		30 x 10 <sup>6</sup> switching cycles			
Electrical lifetime (AC12, 230 V, 4 A)		0.3 x 10 <sup>6</sup> switching cycles	0.1 x 10 <sup>6</sup> switching cycles		
Max. fuse rating to achieve short-circuit protection	n/c / n/o contact	4 A fast-acting / 6 A fast-acting			
<b>General data</b>					
Dimensions (W X H X D)		45 x 78 x 100 mm (1.77 x 3.07 x 3.94 in)			
Mounting position		any			
Degree of protection	enclosure / terminals	IP50 / IP20			
Ambient temperature range	operation / storage	-25...+65 °C / -40...+85 °C			
Mounting		DIN rail (IEC/EN 60715)			
<b>Electrical connection</b>					
Wire size	fine-strand with wire end ferrule	2 x 2.5 mm <sup>2</sup> (2 x 14 AWG)			
<b>Standards</b>					
Product standard		IEC 255-6, EN 60255-6			
Low Voltage Directive		2006/95/EG			
EMC Directive		2004/108/EG			
<b>Electromagnetic compatibility</b>					
electrostatic discharge	IEC/EN 61000-4-2	Level 3 (6 kV / 8kV)			
radiated, radio-frequency, electromagnetic field	IEC/EN 61000-4-3	Level 3 (10 V/m)			
electrical fast transient / burst	IEC/EN 61000-4-4	Level 3 (2 kV / 5 kHz)			
surge	IEC/EN 61000-4-5	Level 4 (2 kV L-L)			
conducted disturbances, induced by radio-frequency fields	IEC/EN 61000-4-6	Level 3 (10 V)			
Resistance to vibration (IEC 68-2-6)		5 g			
Mechanical resistance (IEC 68-2-6)		10 g			
<b>Isolation data</b>					
Rated insulation voltage between supply, measuring and output circuit (VDE 0110, IEC 60947)		250 V	500 V		
Rated impulse withstand voltage between all isolated circuits (VDE 0110, IEC 664)		4 kV / 1.2 - 50 $\mu$ s			
Test voltage between all isolated circuits		2.5 kV, 50 Hz, 1 min.			
Pollution category (VDE 0110, IEC 664, IEC 255-5)		3 / C			
Overvoltage category (VDE 0110, IEC 664, IEC 255-5)		III / C			
Environmental testing (IEC 68-2-30)		24 h cycle time, 55 °C, 93 % rel., 96 h			

<sup>1)</sup> Open-circuit principle: Output relay energizes if the measured value exceeds/drops below the adjusted threshold.  
 Closed-circuit principle: Output relay de-energizes if the measured value exceeds/drops below the adjusted threshold.

# Liquid level monitors and controls

## Notes

Handwriting practice area consisting of horizontal dotted lines.

# Contact protection and Sensor interface relays

## Product group picture

2



# Contact protection and Sensor interface relays

## Table of contents

<b>Contact protection and Sensor interface relays</b>	
Product group picture	2/117
Table of contents	2/118
Ordering details	2/119
Technical information	2/120
Technical data	2/121

# Contact protection and Sensor interface relays

## Ordering details

2

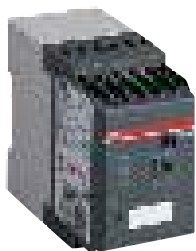

1SVR450 081 F0000

CM-KRN

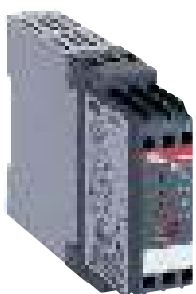

1SVR430 500 F2300

CM-SIS

### Description

#### Contact protection relay:

The CM-KRN protects sensitive control contacts from excessive load. It can be used with latching function or without. Bounce time of control contacts can be bypassed by the adjustable response delay time. Use for contact protection.

#### Senior interface relay:

The CM-SIS is used to supply 2- or 3-wire NPN or PNP sensors with power and to evaluate their switching signals. Two sensors of the types NPN or PNP can be connected simultaneously. Selection is done via the front-face rotary switch.

### Ordering details

Rated control supply voltage	Timing circuit	Type	Order code	Price	Weight (1 pce) kg (lb)
24 V AC	0.05-30 s	CM-KRN	1SVR450089R0000		0.30 (0.66)
110-130 V AC			1SVR450080R0000		0.30 (0.66)
220-240 V AC			1SVR450081R0000		0.30 (0.66)
380-415 V AC			1SVR450082R0000		0.30 (0.66)
24 V AC			1SVR450099R0000		0.30 (0.66)
110-130 V AC			1SVR450090R0000		0.30 (0.66)
220-240 V AC			1SVR450091R0000		0.30 (0.66)
24 V AC/DC <sup>1)</sup>			1SVR450099R1000		0.30 (0.66)
110-240 V AC / 105-260 V DC <sup>2)</sup>		CM-SIS	1SVR430500R2300		0.22 (0.48)

<sup>1)</sup> Not electrically isolated

<sup>2)</sup> Safe isolation, short circuit and overload proof

#### Characteristics CM-KRN

- Protects and reduces load from sensitive control contacts
- Adjustable ON-delay 0.05-30 s
- Acts as two-position switch
- Stores switch positions
- Electrically isolated circuits
- 2 c/o contacts
- 2 LEDs for status indication

#### Characteristics CM-SIS

- High efficiency
- Low heating
- Wide range of supply voltage
- Constant output voltage 24 V DC
- Safe isolation acc. to EN 50178 (VDE 0160)
- Short-circuit and overload proof
- Input protected by internal fuse
- 2 x 1 c/o contact
- 3 LEDs for status indication

# Contact protection and Sensor interface relays

## Technical information

Use for contact protection. The contact to be protected is connected to terminals Y1 and Y2. Use for contact protection with latching capacity. The output relay energizes after contact Y1-Y3 has been closed for at least 20 ms. It remains energized until contact Y1-Y4 closes. The switching positions are stored. The relay is suitable for load reduction purposes for devices with minimum and maximum contacts. The CM-KRN can be operated via 3-wire proximity sensors for switching of higher power. The supply circuit, the control circuit and the output circuit are electrically isolated against each other.

Function diagram CM-KRN

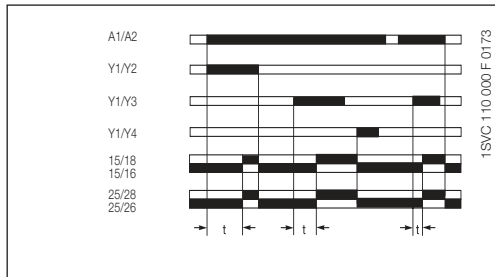

Connection diagram CM-KRN

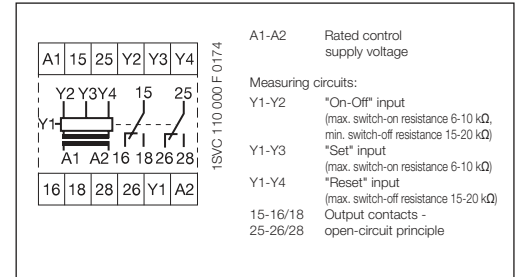

Use, applications

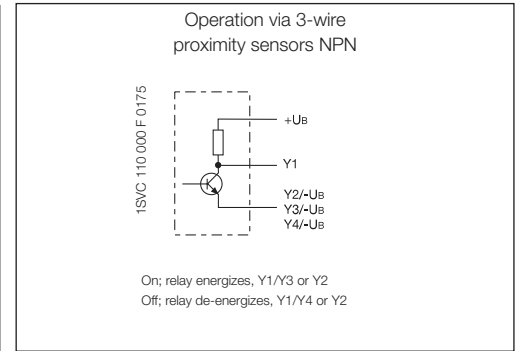
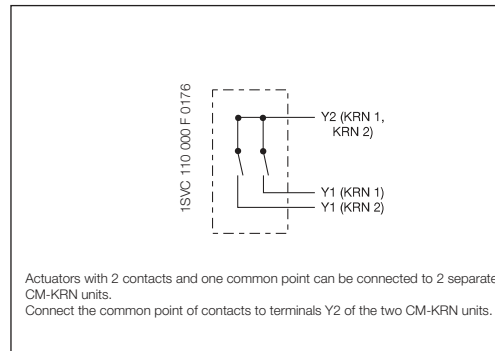

The CM-SIS (terminals L+, L-) supplies the connected sensors with voltage (24 V DC), the maximum power supply current is 0.5 A. The supply voltage and the sensor inputs are electrically isolated from the supply circuit. To ensure maximum safety when using these sensors, the principle of safe isolation has been included.

Each sensor input signal energizes the corresponding output relay without delay. The relay is energized as soon as a threshold current is exceeded at input I1 or I2. Sensor leakage currents of up to 8 mA don't affect the evaluation. The threshold value is about 9 mA. If the threshold value at input I1 or I2 is exceeded the corresponding relay R1 or R2 energizes and the corresponding LED lights up.

The wide-range supply voltage input of CM-SIS allows its application in nearly all supply systems.

The CM-SIS is also suitable for other applications, for example it is also possible to connect PTC or NTC resistors instead of PNP or NPN sensors or to operate the SIS directly by switching contacts.

Function diagram CM-SIS

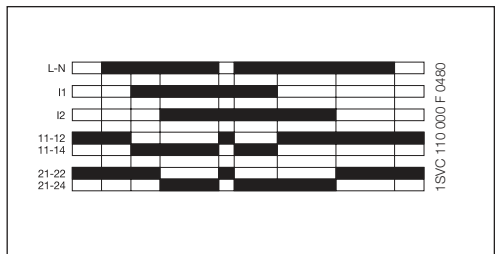

Connection diagram CM-SIS

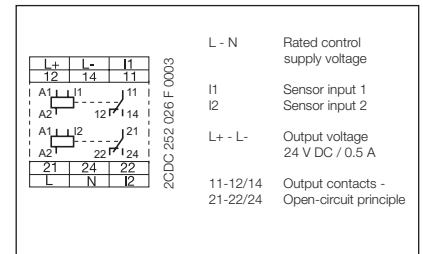

Connection of 2-wire sensors

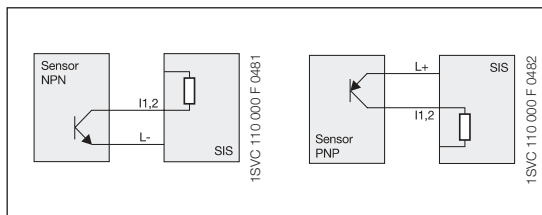

Connection of 3-wire sensors

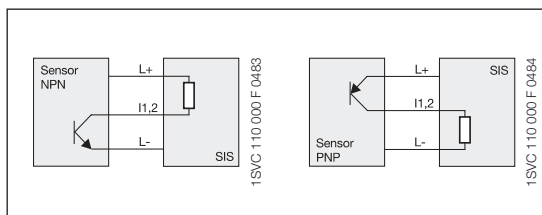





# Contact protection and Sensor interface relays

## Technical data

2

<b>Type</b>		<b>CM-KRN</b>
<b>Supply circuit</b>		<b>A1-A2</b>
Rated control supply voltage $U_s$ - power consumption	A1-A2	24 V AC - approx. 3.5 VA
	A1-A2	24 V AC/DC - approx. 3.5 VA
	A1-A2	110-130 V AC - approx. 3,5 VA
	A1-A2	220-240 V AC - approx. 3.5 VA
	A1-A2	380-415 V AC - approx. 3.5 VA
Rated control supply voltage $U_s$ tolerance		-15...+10 %
Rated frequency		50-60 Hz
Duty time		100 %
<b>Timing circuit</b>		
ON-delay time		0.05-1 s, 1.5-30 s
OFF-delay time		max. 50 ms
<b>Measuring circuit / contact circuit</b>		<b>Y1-Y2/Y3/Y4</b>
Measuring input	contact protection without latching	Y1-Y2
	contact protection with latching	Y1-Y3/Y4
Threshold	Y1-Y2/Y3	6-10 k $\Omega$
Threshold-Hysteresis	Y1-Y2/Y4	15-20 k $\Omega$
No-load voltage at the measuring input		$\leq$ 10 V DC
Contact time for latching (CM-KRN without timing circuit)		min. 20 ms
Switching current at the measuring input		3 mA
Maximum applied voltage at the measuring input		$\leq$ $\pm$ 30 V (contact voltage)
<b>Indication of operational states</b>		
Control supply voltage	U: green LED	 : control supply voltage applied
Relay status	R: yellow LED	 : output relay energized
Output circuit		15-16/18, 25-26/28
Kind of output		relay, 2 c/o contacts
Operating principle <sup>1)</sup>		open-circuit principle
Rated operational voltage (VDE 0110, IEC 60947-5-1)		400 V
Rated switching voltage		400 V AC
Rated operational current $I_n$ (IEC/EN 60947-5-1)	AC12 (resistive) 230 V	5 A
	AC15 (inductive) 230 V	3 A
	DC12 (resistive) 24 V	5 A
	DC13 (inductive) 24 V	2.5 A
AC rating (UL 508)	Utilization category (Control Circuit Rating Code)	B 300
	max. rated operational voltage	300 V AC
	max. continuous thermal current at B 300	5 A
	max. making/breaking apparent power at B 300	3600/360 VA
Mechanical lifetime		$30 \times 10^6$ switching cycles
Electrical lifetime (AC12, 230 V, 5 A)		$0.1 \times 10^6$ switching cycles
Max. fuse rating to achieve short-circuit protection	n/c / n/o contact	10 A fast-acting / 10 A fast-acting
<b>General data</b>		
Dimensions (W x H x D)		45 x 78 x 100 mm (1.77 x 3.07 x 3.94 in)
Mounting position		any
Degree of protection	enclosure / terminals	IP20 / IP50
Ambient temperature range	operation / storage	-25...+65 °C / -40...+85 °C
Mounting		DIN rail (IEC/EN 60715)
<b>Electrical connection</b>		
Wire size	fine-strand with wire end ferrule	2 x 2.5 mm <sup>2</sup> (2 x 14 AWG)
<b>Standards</b>		
Product standard		IEC 255-6, EN 60255-6
Low Voltage Directive		2006/95/EC
EMC Directive		2004/108/EC
<b>Electromagnetic compatibility</b>		
Interference immunity to electrostatic discharge	IEC/EN 61000-4-2	6 kV / 8 kV
radiated, radio-frequency, electromagnetic field	IEC/EN 61000-4-3	10 V/m
electrical fast transient / burst	IEC/EN 61000-4-4	2 kV / 5 kHz
surge	IEC/EN 61000-4-5	2 kV symmetrical
conducted disturbances, induced by radio-frequency fields	IEC/EN 61000-4-6	10 V
<b>Isolation data</b>		
Rated insulation voltage (IEC 60947-1)		400 V
Rated impulse withstand voltage $U_{imp}$ (IEC 644-6)		4 kV
Pollution category (IEC 255-5, IEC 664)		3
Overvoltage category (IEC 255-5, IEC 664)		III

<sup>1)</sup> Open-circuit principle: Output relay is energized if the measured value exceeds/drops below the adjusted threshold.

# Contact protection and Sensor interface relays

## Technical data

Type		CM-SIS	
<b>Input circuit</b>			
Supply voltage	L-N	AC	110-240 V AC (-15...+10 %)
		DC	110-240 V (max. 105-260 V DC)
Frequency, AC supply			47-440 Hz
Supply voltage failure bridging time			10 ms min. at 100 % load
Current consumption		max.	0.35 A
		at 115 V AC	0.27 A
		at 230 V AC	0.14 A
Inrush current at 25°C (≤ 2 ms)			33 A
Internal input fuse			800 mA slow-acting
<b>Measuring circuit</b>		<b>L+, L- / I1, I2</b>	
Sensor voltage	L+ L-		24 V DC ± 3%
Sensor current / power			max. 0.5 A / 12 W
Residual ripple			max. 100 mV <sub>pp</sub>
Deviation with		load change statical	max. ± 0.5 %
		load change dynamical 10-90 % change of the input voltage	max. .5 %
			max. ± 0.5 %
Short-circuit protection			overcurrent switch-off with automatic restart
Overload protection			excess temperature and overcurrent switch-off
Reset after thermal overload switch-off			automatic reset after cooling down
Sensor type connection possibilities		I1, I2	2- or 3-wire connection, NPN or PNP selectable by front-face switch
Input resistance			approx. 2.5 kΩ
Threshold value for relays R1, R2			$U_{\text{emitter-collector}} < 2,3 \text{ V}$ (I1, I2 > 8 mA)
Maximum switching frequency			approx. 20 Hz
<b>Output circuit</b>		<b>11-12/14, 21-22/24</b>	
Kind of output			2 relays, 1 c/o contact each
Operating principle <sup>1)</sup>			open-circuit principle
Rated operational voltage			250 V
Maximum switching voltage			250 V AC
Rated operational current I <sub>o</sub> (IEC/EN 60947-5-1)		AC12 (resistive) 230 V	4 A
		AC15 (inductive) 230 V	3 A
		DC12 (resistive) 24 V	4 A
		DC13 (inductive) 24 V	2 A
AC rating (UL 508)	Utilization category (Control Circuit Rating Code)		B 300
	max. rated operational voltage		300 V AC
	max. continuous thermal current at B 300		5 A
	max. making/breaking apparent power at B 300		3600/360 VA
Mechanical lifetime			10 x 10 <sup>6</sup> switching cycles
Electrical lifetime			0.1 x 10 <sup>6</sup> switching cycles
Max. fuse rating to achieve short-circuit protection	n/c / n/o contact		6 A fast-acting / 10 A fast-acting
<b>Indication of operational states</b>			
Control supply voltage	U: green LED		: control supply voltage applied
Relay status R1	R1: yellow LED		: threshold value at input I1 exceeded
Relay status R2	R2: yellow LED		: threshold value at input I2 exceeded
<b>General data</b>			
Efficiency at rated load			approx. 84 % (at 230 V AC)
Ambient temperature range	operation / storage		0...+55 °C / -25...+75 °C
Dimensions (W x H x D)			22.5 x 78 x 100 mm (0.89 x 3.07 x 3.94 in)
Mounting position			horizontally
Mounting			DIN rail (IEC/EN 60715)
Minimum distance to other units			left-hand side 10 mm (0.39 in), vertical distance 50 mm (1.97 in)
<b>Electrical connection</b>			
Wire size			2 x 2,5 mm <sup>2</sup> (2 x 14 AWG)
<b>Standards</b>			
Product standard			IEC 255-6, EN 60255-6
Electrical safety			IEC(EN) 60255-5, EN 50178 (VDE 0160), EN60950, UL 508, CSA 22.2
Galvanic isolation			safe isolation between L+,L-, I1,I2, and L,N,I1,I2,I4,I2,I2,I2,I4
<b>Electromagnetic compatibility</b>			
Interference immunity to electrostatic discharge	IEC/EN 61000-4-2		EN 61000-6-2 Level 3 (6 / 8 kV)
radiated, radio-frequency, electromagnetic field	IEC/EN 61000-4-3		Level 3 (10 V/m)
electrical fast transient / burst	IEC/EN 61000-4-4		Level 4 (4 kV)
surge	IEC/EN 61000-4-5		Inst. class 3 (2 kV)
conducted disturbances, induced by radio-frequency fields	IEC/EN 61000-4-6		Level 3 (10 V)
Interference immunity to Input current harmonics	EN 50081-2		radiated noise EN 55011, class B no limitation
<b>Isolation data</b>			
Insulation testing			2.5 kV AC (routine test), 3 kV AC (type test)
Degree of pollution			2
Overvoltage category			II

<sup>1)</sup> Open-circuit principle: Output relay is energized if the measured value exceeds/drops below the adjusted threshold.

# Cycle monitoring relay with watchdog function

## Product group picture

2



# Cycle monitoring relay with watchdog function

## Table of contents

<b>Cycle monitoring relay with watchdog function</b>	
Product group picture	2/123
Table of contents	2/124
Ordering details	2/125
Technical data	2/126

# Cycle monitoring relay with watchdog function

## Ordering details

2



CM-WDS

2CDC251 002 F0004

### Description

The cycle monitoring relay CM-WDS (watchdog) observes if a regularly intermittent pulse is applied to its pulse input "I". It is, for example, possible to connect the output of a programmable logic controller (plc), which is set and reset regularly (e. g. once each cycle). The connected cycle pulse must be generated by suitable programming of the plc/ipc. Now, the CM-WDS monitors if the cycle time of the plc/ipc program is smaller than the cycle monitoring time set by means of the front-face selector switch "time value (ms)".

The output relay 11-12/14 of the CM-WDS energizes and the red LED is switched off, if there are minimum 8 successive regular pulses on input "I". When the pulse signal stays out or is not regular, the output relay de-energizes and the red LED is illuminated.

In case the monitoring time is too short or too long, this can be adjusted by a modified programming of the plc/ipcs or by modified setting of the monitoring time "time value (ms)".

A fault recognized and stored with the CM-WDS can be reset by an H-impulse (0-1-transition) on the reset input "R(9)", so that the cycle monitoring is again released. The reset impulse can be generated by means of a reset button or by suitable programming of the controller (plc/ipc).

### Ordering details

Rated control supply voltage	Type	Order code	Price 1 pce	Weight (1 pce) kg (lb)
24 V DC	CM-WDS	1SVR430896R000		0.15 (0.33)

### Function diagram CM-WDS

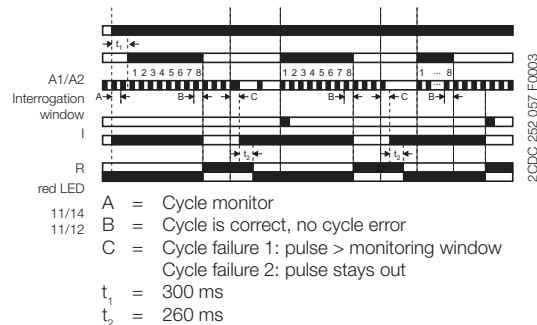

### Connection diagram CM-WDS

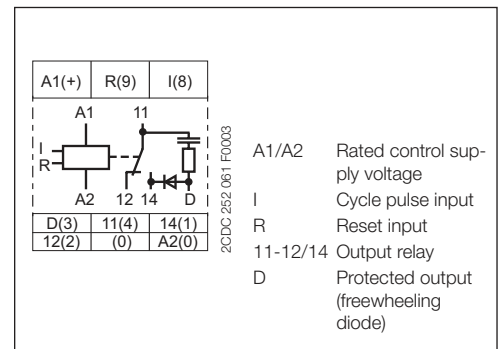

### Characteristics

- Cycle monitor for monitoring the function of programmable logic controllers or industrial pcs
- 4 selectable cycle monitoring time ranges from 0.5 to 1000 ms
- 24 V DC supply
- 1 c/o contact
- 2 LEDs for status indication

### Example of application - circuit diagram

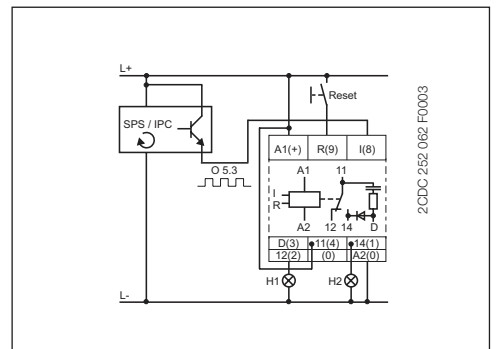

### Application

The CM-WDS is designed for the external monitoring of the correct function of programmable logic controllers (plc) and industrial pcs (ipc).

# Cycle monitoring relay with watchdog function

## Technical data

<b>Type</b>	<b>CM-WDS</b>	
<b>Input circuit</b>	<b>A1-A2</b>	
Rated control supply voltage $U_s$ - power consumption A1-A2	24 V DC - approx. 1 W	
Tolerance of the rated control supply voltage $U_s$	-30 % - +30 %	
Duty time	100 %	
<b>Measuring circuit</b>	I	
Monitoring function	cycle monitoring	
Measuring voltage	24 V DC	
Current consumption at the measuring input	approx. 5 mA	
Setting range of cycle monitoring time	selectable: 0.5-150 ms, 0.5-260 ms, 0.5-500 ms, 0.5-1000 ms	
Response time	approx. 0.5-1000 ms	
Accuracy within the supply voltage tolerance	$\Delta U \leq 0.5 \%$	
Accuracy within the temperature range	$\Delta U \leq 0.06 \%$ / °C	
<b>Timing circuit</b>		
ON-delay	approx. 2.2-10 s	
<b>Indication of operational states</b>		
Control supply voltage	U: green LED	
Output relay de-energized / cycle error	F: red LED	
<b>Output circuit</b>	<b>11-12/14</b>	
Kind of output	1 c/o	
Operating principle <sup>1)</sup>	Closed-circuit principle	
Contact material	AgCdo	
Rated operational voltage $U_o$	IEC/EN 60947-1	250 V
Minimum switching voltage / Minimum switching current	250 V AC, 250 V DC	
Maximum switching voltage	4 A	
Rated operational current $I_o$ (IEC/EN 60947-5-1)	AC12 (resistive) 230 V	4 A
	AC15 (inductive) 230 V	3 A
	DC12 (resistive) 24 V	4 A
	DC13 (inductive) 24 V	2 A
AC rating (UL 508)	Utilization category (Control Circuit Rating Code)	B 300
	max. rated operational voltage	300 V AC
	max. continuous thermal current at B 300	5 A
	max. making/breaking apparent power at B 300	3600/360 VA
Mechanical lifetime	10 x 10 <sup>6</sup> switching cycles	
Electrical lifetime (AC12, 230 V, 4 A)	0.1 x 10 <sup>6</sup> switching cycles	
Max. fuse rating to achieve short-circuit protection	n/c / n/o contacts	10 A fast-acting / 10 A fast-acting
<b>General data</b>		
Dimensions (W x H x D)	22.5 x 78 x 100 mm (0.89 x 3.07 x 3.94 in)	
Mounting position	any	
Degree of protection	enclosure / terminals	IP50 / IP20
Ambient temperature range	operation / storage	-20...+60 °C / -40...+85 °C
Mounting	DIN rail (IEC/EN 60715)	
<b>Electrical connection</b>		
Wire size	fine-strand with wire end ferrule	2 x 2.5 mm <sup>2</sup> (2 x 14 AWG)
<b>Standards</b>		
Product standard	IEC 255-6, EN 60255-6	
Low Voltage Directive	2006/95/EC	
EMC Directive	2004/108/EC	
Operational reliability (IEC 68-2-6)	4 g	
Mechanical shock resistance (IEC 68-2-6)	6 g	
<b>Electromagnetic compatibility</b>		
Interference immunity to	EN 61000-6-2	
electrostatic discharge	IEC/EN 61000-4-2	Level 3 (6 kV / 8 kV)
radiated, radio-frequency, electromagnetic field	IEC/EN 61000-4-3	Level 3 (10 V/m)
electrical fast transient / burst	IEC/EN 61000-4-4	Level 3 (2 kV / 5 kHz)
surge	IEC/EN 61000-4-5	Level 3 (2 kV L-L)
conducted disturbances, induced by radio-frequency fields	IEC/EN 61000-4-6	Level 3 (10 V)
Interference emission	EN 61000-6-4	
<b>Isolation data</b>		
Rated insulation voltage between supply-, control- and output circuit (VDE 0110, IEC 60947-1)	250 V	
Rated impulse withstand between all isolated circuits (VDE 0110, IEC 664)	4 kV / 1.2-50 $\mu$ s	
Test voltage between all isolated circuits	2.5 kV, 50 Hz, 1 min	
Pollution degree (VDE 0110, IEC 664, IEC 255-5)	3/C	
Overvoltage category (VDE 0110, IEC 664, IEC 255-5)	III	
Environmental tests (IEC 68-2-30)	24 h cycle, 55 °C, 93 % rel. 96 h	

<sup>1)</sup> Closed-circuit principle: Output relay de-energizes if a cycle error occurs



# General technical data, Accessories, Current transformers

## Table of contents

<b>General technical data, Accessories, Current transformers</b>	
Notes	2/127
Table of contents	2/128
Technical diagrams - CM-range	2/129
Dimensional drawings	2/130
Ordering details - CM-range accessories	2/131



# General technical data, Accessories, Current transformers

## Technical diagrams - CM-range

### Load limit curves

CM-S (22.5 mm), CM-E (22.5 mm)

AC load (resistive)

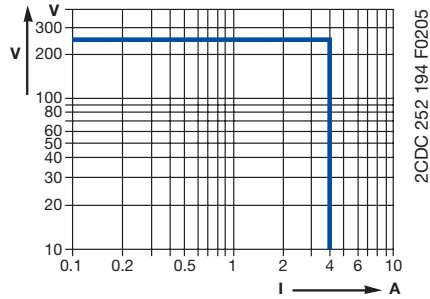

DC load (resistive)

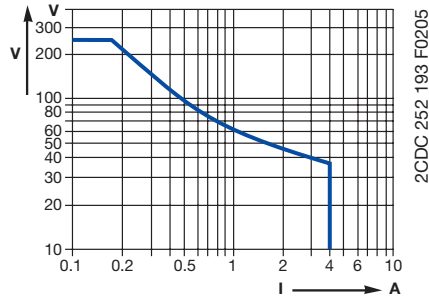

Derating factor F for inductive AC load

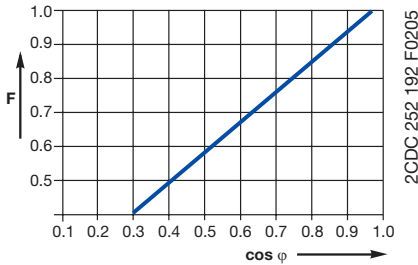

Contact lifetime

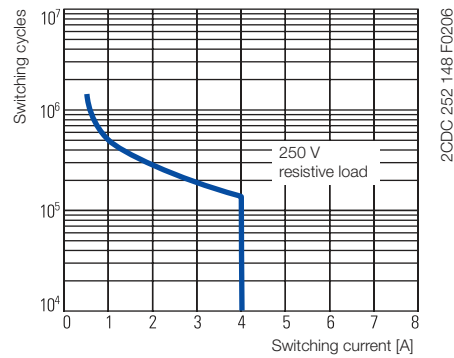

CM-N (45 mm)

AC load (resistive)

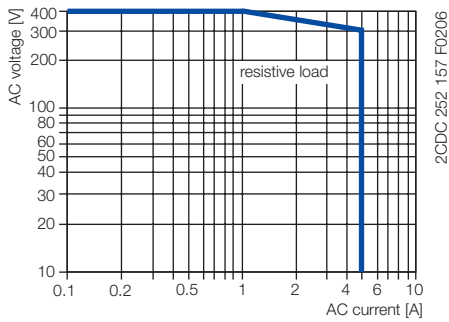

DC load (resistive)

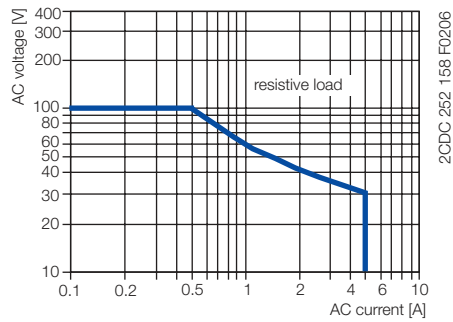

Derating factor F for inductive AC load

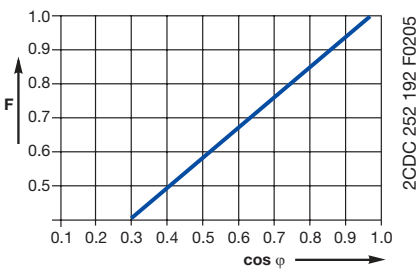

Contact lifetime

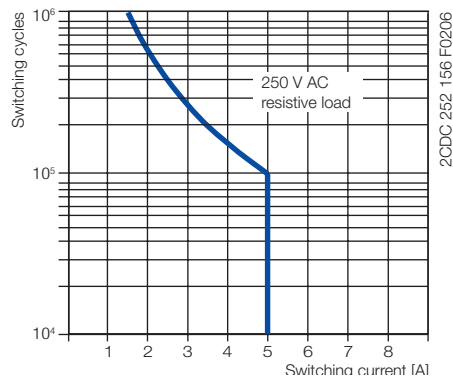

# General technical data, Accessories, Current transformers

## Dimensional drawings

### Measuring and monitoring relays CM range old housing

Dimensions in mm

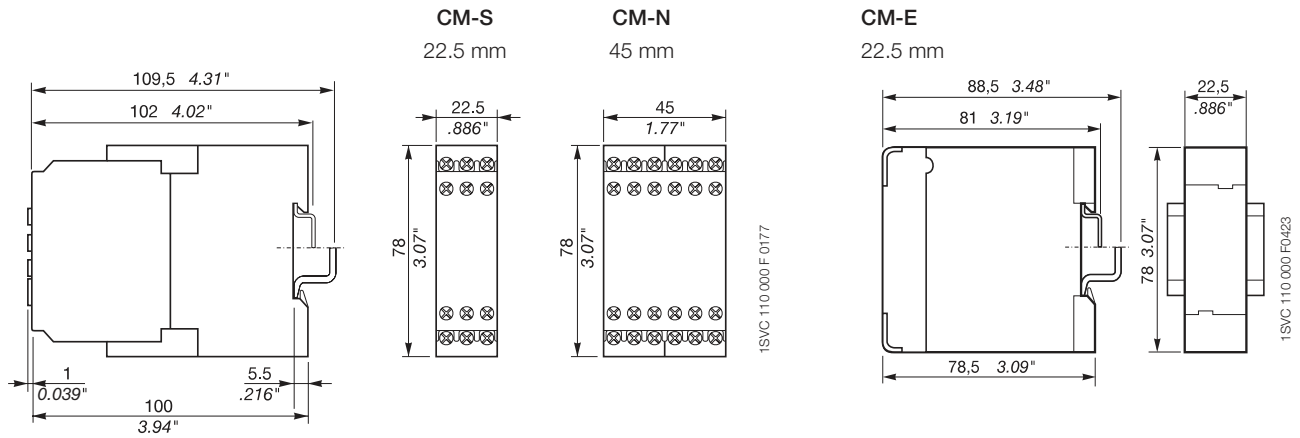

### Measuring and monitoring relays CM range new housing

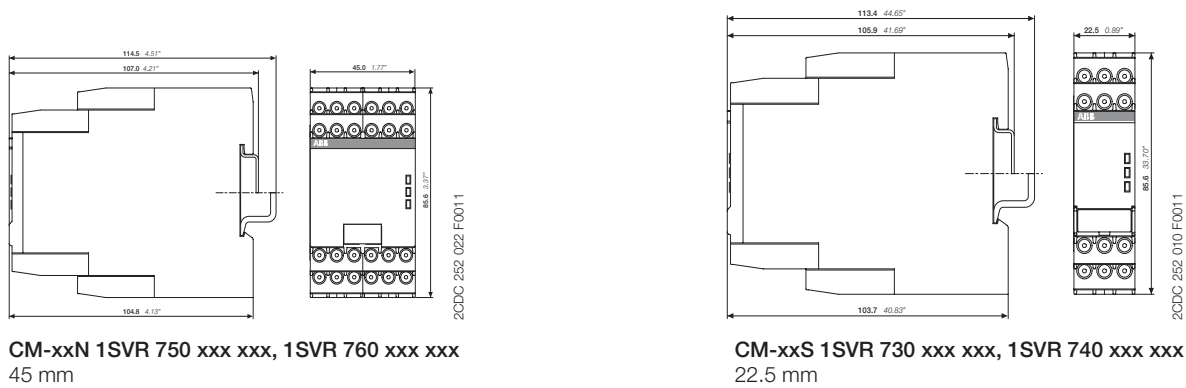

CM-xxN 1SVR 750 xxx xxx, 1SVR 760 xxx xxx  
45 mm

CM-xxS 1SVR 730 xxx xxx, 1SVR 740 xxx xxx  
22.5 mm

### Temperature monitoring relays

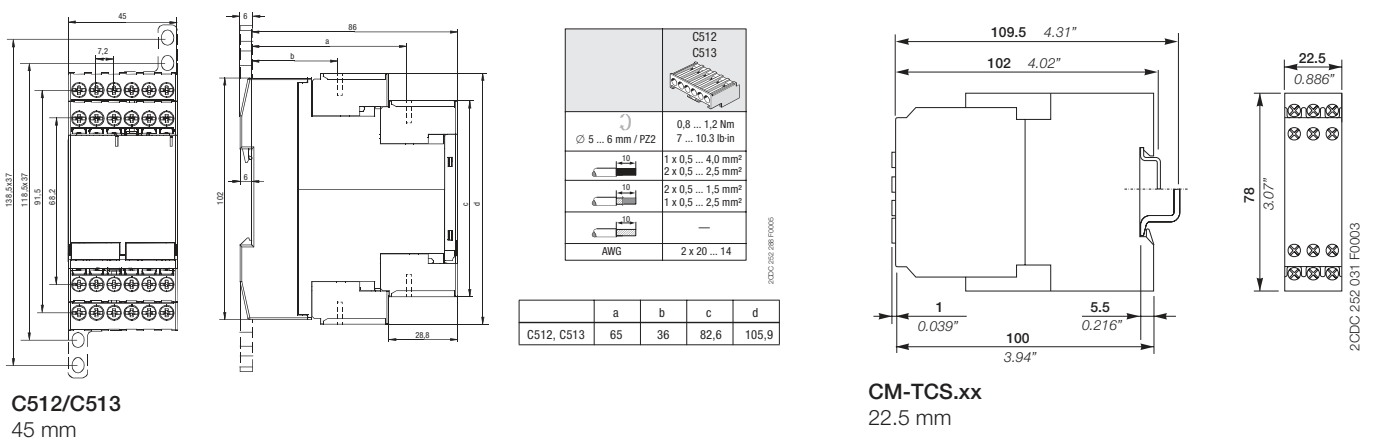

C512/C513  
45 mm

CM-TCS.xx  
22.5 mm

# General technical data, Accessories, Current transformers

## Ordering details - CM-range accessories

2

### Accessories

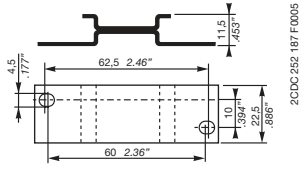

ADP.01

2CDC 252 187 F0005



MAR.01

2CDC 252 186 F0005

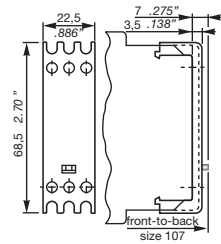

Sealable cover  
COV.01

2CDC 252 186 F0005

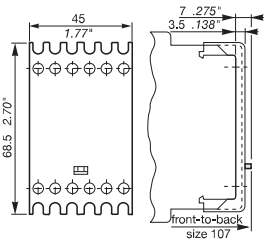

Sealable cover  
COV.02

1SVC 110 000 F 0190

#### Ordering details

Description	For type	Width in mm	for devices	Type	Order code	Price pce	Pkg qty	Weight (1 pce) g (oz)
Adapter for screw mounting	CM-S	22.5		ADP.01	1SVR430029R0100		1	18.4 (0.65)
	CM-N	45		ADP.02	1SVR440029R0100		1	36.7 (1.30)
Marker label	CM-S, CM-N		without DIP switches	MAR.01	1SVR366017R0100		10	0.19 (0.007)
	CM-S, CM-N		with DIP switches	MAR.02	1SVR430043R0000		10	0.13 (0.005)
	CM-S, CM-N in new housing		with DIP switches	MAR.12	1SVR730006R0000		10	0.152 (0.335)
Sealable transparent cover	CM-S	22.5		COV.01	1SVR430005R0100		1	5.2 (0.18)
	CM-N	45		COV.02	1SVR440005R0100		1	7.7 (0.27)
	CM-S.S/P	22.5		COV.11	1SVR730005R0100		1	4.0 (0.129)
	CM-N.S/P	45		COV.12	1SVR750005R0100		1	7 (0.247)

# General technical data, Accessories, Current transformers

## Ordering details - CM-range accessories

2CDC 251 002 F0005



CM-CT

### Plug-in current transformers CM-CT

- Without primary conductor though with foot angle, insulating protective cap and bar fastening screws
- Primary / rated current from 50 A to 600 A
- Secondary current of 1 A or 5 A
- Class 1

### Ordering details

Rated primary current	Secondary current	Burden class	Type	Order code	Price pce	Weight (1 pce) g (oz)
50 A	1 A	1 VA / 1	CM-CT 50/1	1SVR450116R1000		0.31 (0.683)
75 A		1.5 VA / 1	CM-CT 75/1	1SVR450116R1100		0.31 (0.683)
100 A		2.5 VA / 1	CM-CT 100/1	1SVR450116R1200		0.276 (0.608)
150 A		2.5 VA / 1	CM-CT 150/1	1SVR450116R1300		0.32 (0.705)
200 A		2.5 VA / 1	CM-CT 200/1	1SVR450116R1400		0.222 (0.489)
300 A		5 VA / 1	CM-CT 300/1	1SVR450117R1100		0.29 (0.639)
400 A		5 VA / 1	CM-CT 400/1	1SVR450117R1200		0.27 (0.595)
500 A		5 VA / 1	CM-CT 500/1	1SVR450117R1300		0.29 (0.639)
600 A	5 VA / 1	CM-CT 600/1	1SVR450117R1400		0.24 (0.529)	
50 A	5 A	1 VA / 1	CM-CT 50/5	1SVR450116R5000		0.3 (0.661)
75 A		1.5 VA / 1	CM-CT 75/5	1SVR450116R5100		0.31 (0.683)
100 A		2.5 VA / 1	CM-CT 100/5	1SVR450116R5200		0.31 (0.683)
150 A		2.5 VA / 1	CM-CT 150/5	1SVR450116R5300		0.28 (0.617)
200 A		5 VA / 1	CM-CT 200/5	1SVR450116R5400		0.29 (0.639)
300 A		5 VA / 1	CM-CT 300/5	1SVR450117R5100		0.252 (0.556)
400 A		5 VA / 1	CM-CT 400/5	1SVR450117R5200		0.26 (0.573)
500 A		5 VA / 1	CM-CT 500/5	1SVR450117R5300		0.208 (0.459)
600 A		5 VA / 1	CM-CT 600/5	1SVR450117R5400		0.21 (0.463)

2CDC 251 003 F0005



CM-CT with mounted accessories

### Ordering details - Accessories

Description	Type	Order code	Price 10 pces	Weight (1 pce) g (oz)
Snap-on fastener for DIN rail mounting of CM-CT	CM-CT A	1SVR450118R1000		0.009 (0.02)

2CDC 251 159 F0006



CM-CT-A mounted on DIN rail

### Operating principle / circuit diagram

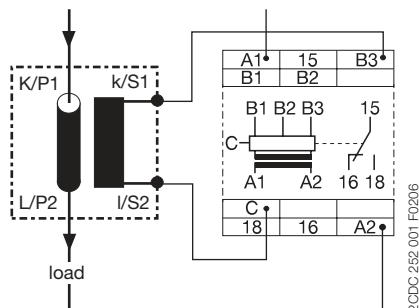

2CDC 252 001 F0206

### Dimensional drawing

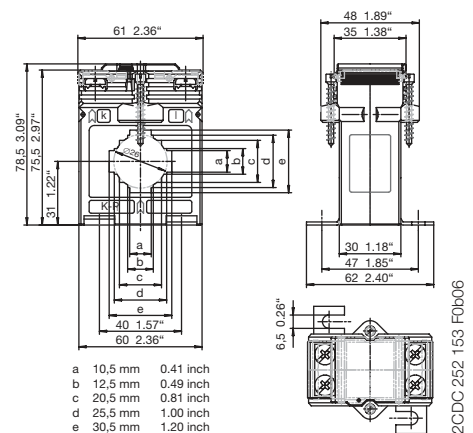

2CDC 252 153 F0006