



Schindler 5500

High-performance and sophisticated, flexible design in a mid-rise elevator.



Schindler

us.schindler.com



Fast facts

Capacity	2100 – 5000 lbs.
Travel height	Up to 350 feet
Stops/Openings	33 stops, with up to 45 openings
Door width	36, 42, 48 and 54 inches
Door height	7, 8 and 9 feet
Car height	8, 9 and 10 feet
Drive	PF1 regenerative drive standard
Speed	200, 350, 500 FPM
Car groups	Up to 8 cars expandable with PORT Technology
Compliance	Meets applicable federal, state and local codes. Check with your local sales representative for details.

Essentials for a perfect fit.

Schindler 5500

Layout flexibility

The Schindler 5500 is easily configured to meet the unique specifications and needs of your building. The entire system can be self-contained within the hoistway to speed installation and save valuable space.

High-level performance

Our powerful, compact drives can meet greater building heights and deliver quiet performance with noticeably smoother rides. Our trailblazing PORT Technology helps move more passengers in less time.

Freedom of design

From functional to sophisticated, pre-configured to custom – our design options give you the freedom to create stylish elevators that are the perfect complement to your building.

Green mobility

The Schindler 5500 helps lower your building's carbon footprint by utilizing Power Factor 1 regenerative drives, optimized motors and innovative traction media.

Layout flexibility

Configure a mobility solution with perfectly fitting cars and a smooth flow of people and goods. Machine room-less (MRL) or machine room above (MRA) options are available to make your building work your way.

More options mean a better fit

The elevator that conforms to your specifications

You determine the dimensions that best suit your ideas and the requirements of your building.

The Schindler 5500 will fit because:

- Standard car sizes are adaptable in width and depth with a maximum of 4" (100mm) around ISO standards.
- Variable car heights available in 8', 9', 10'.
- A single modular system is able to cover different market applications such as residential, commercial and public transportation

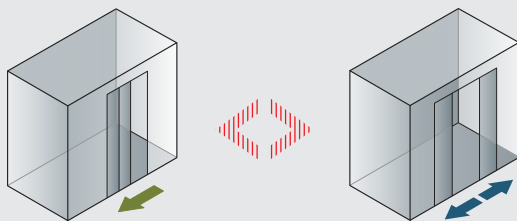
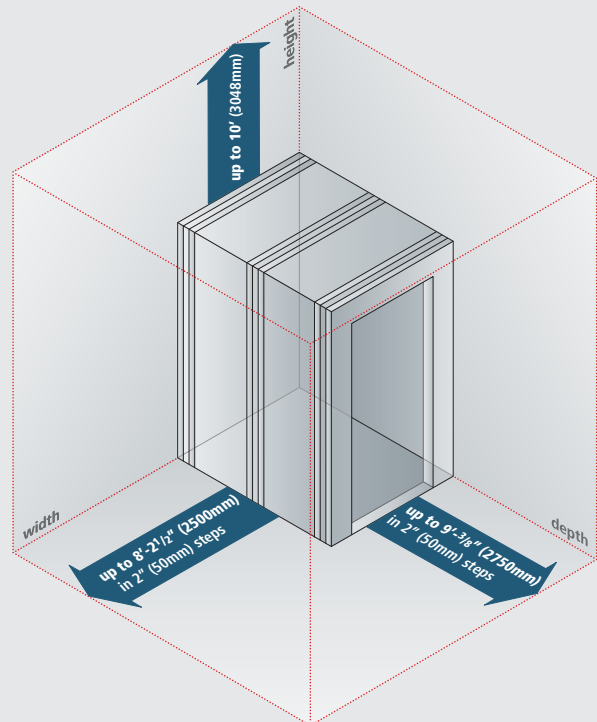

Standard and extended door range

The large range of door widths and heights adapts to code and building requirements.

- Maximum door height: 9'
- Maximum door width: General purpose – 4' and hospital service – 4'-6"

Doors are available in different finishes, including glass panels.

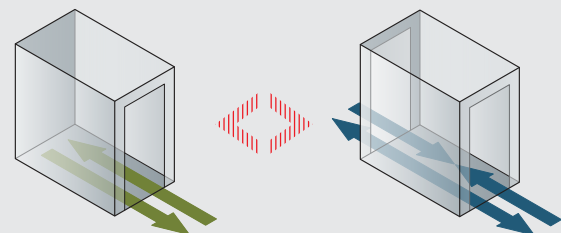

Front only or front/rear openings

For increased traffic handling efficiency, cars are available with smooth opening doors on both sides.

Building integration made easy

MRL and MRA layout

Depending on the dimensions of the hoistway, capacity and travel height requirements, there are MRL and MRA solutions for the Schindler 5500. MRL design is available for nearly all configurations. In addition, side or rear counterweights provide more options for perfect space utilization, maximized rentable space and lower building costs.

Why side counterweights?

	Side	Rear
Machine loads supported by the hoistway, not the building	✓	–
Contractor not required to provide pockets of machine support	✓	–
Lower hoistway construction costs	✓	–
Up to 20% faster installation with less coordination required with the contractor	✓	–
Machine can be raised through the hoistway without a crane	✓	–
Building can be topped off prior to elevator installation	✓	–

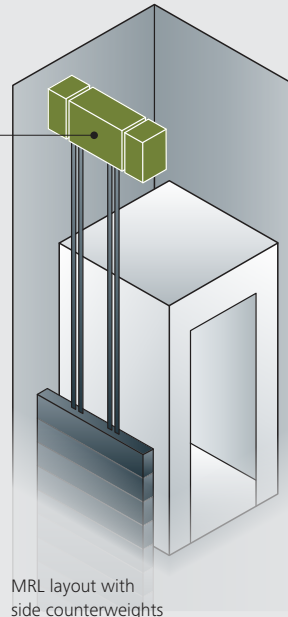

Elevator machine loads transferred to the building

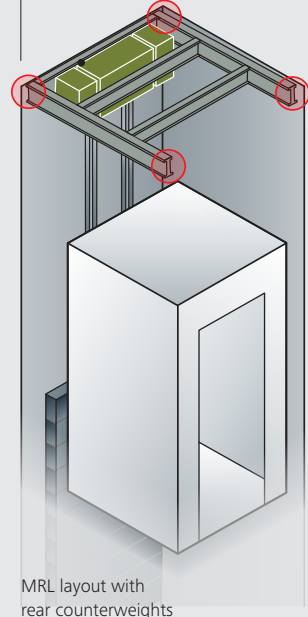

Smart design saves space

Compact and powerful regenerative drives can be mounted at the top of the hoistway, eliminating a machine room and adding more usable space to the building.

The space-efficient controller fits neatly into the top floor of the elevator door jamb, eliminating the need for even a small control closet in most applications.

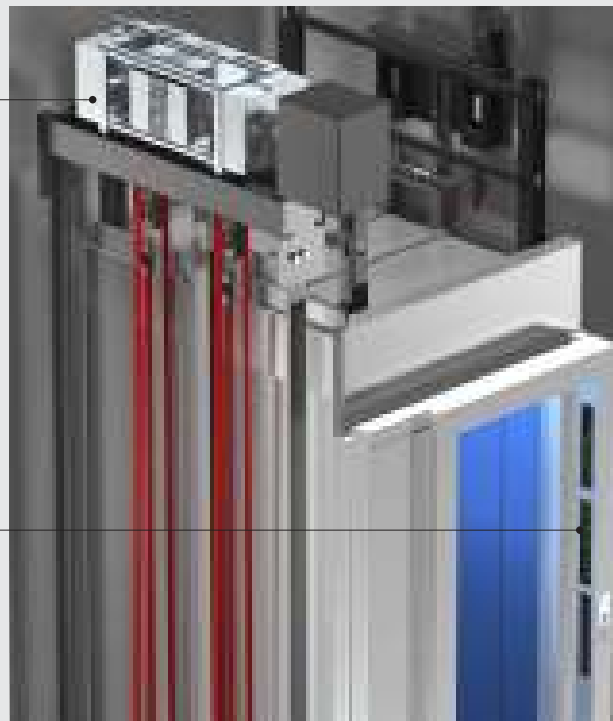

High-level performance

The enhanced Schindler 5500 offers smoother rides, with noise reduction and superior traffic management.

A new standard in the mid-rise building market

The Schindler 5500 has been engineered to deliver the combined benefits of reliable performance, greater travel heights, faster speeds, lower noise levels and less vibration.

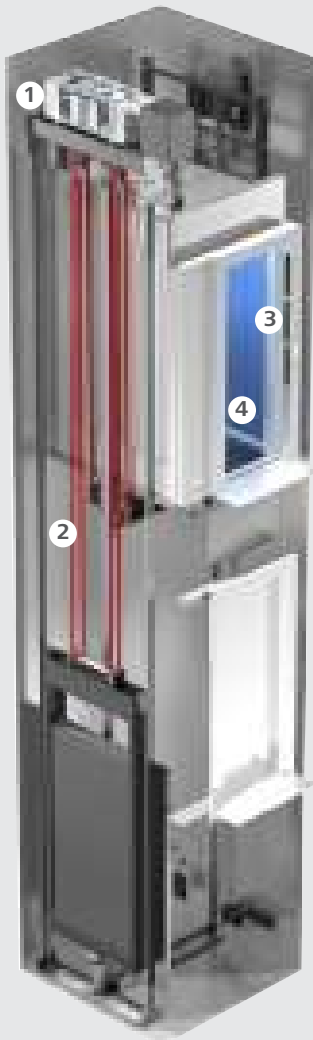

1 Drive

Reaching heights of up to 350 feet, our high-performance gearless machine is economical and environmentally-friendly. Variable-frequency control delivers a smooth ride, substantially less vibration. Advanced compact motor is optimized to save energy, emit minimal heat and run quietly.

2 Suspension traction media

Our innovative suspension traction media (STM) is lighter and needs less space than conventional steel ropes. Less noise is transmitted to the car and building while ride comfort is significantly improved.

3 Control

The integrated microprocessor control system manages the diverse operations of up to eight elevators. Numerous control options are available, including VIP service, hospital emergency and Sabbath operation.

4 Car

The car is centrally guided and ideally balanced to reduce friction and energy loss. Car dimensions are flexible, offering greater planning freedom. Car and landing operating panels have easy to read, energy-saving LED indicators.

Measurably better performance

Schindler is committed to meeting the ever-expanding global demand for better mobility solutions. The Schindler 5500 is another example of how we deliver higher levels of performance in the areas that matter most.

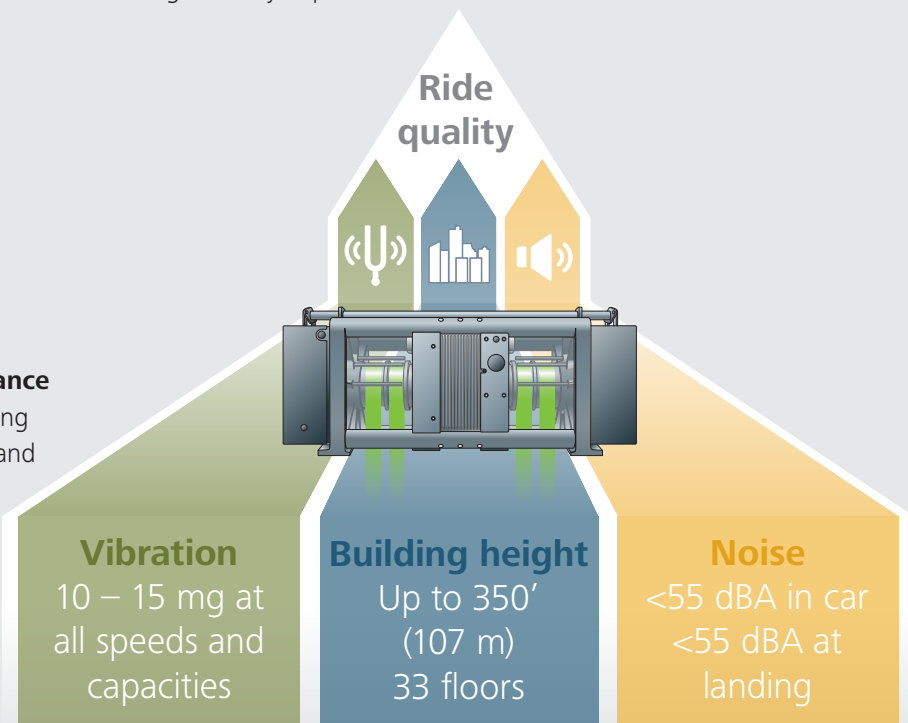

Powerful performance when paired with Schindler's PORT Technology



Brainpower for your building

Our optional Schindler PORT Technology is the highest standard for optimizing traffic flow through a building with flexible personalization and access capabilities. When compared to a conventional traffic management system, Schindler PORT Technology offers unmatched advantages.

The brain behind PORT Technology is a powerful software system that uses information to guide and transport people quickly and safely to their individual destinations. Passengers communicate through a simple yet elegant interface device called the PORT.

The PORT system calculates the optimum route to any destination within the building, assigns the best elevator to handle that call and then brings each passenger to their destination faster with fewer intermediate stops. Enabled with radio frequency identification (RFID) technology, the PORT system can identify individual travelers to customize their trip and provide personal service.

The system is also able to 'learn' how a building's occupants move, anticipating passenger needs to optimize flow and manage resources more effectively. It's the perfect choice for smarter, greener buildings.



The PORT Terminal

This new range of hall call destination terminals delivers brainpower to your building. Various PORT Terminal options are available to optimize traffic flows. For detailed information, visit www.theporttechnology.com.

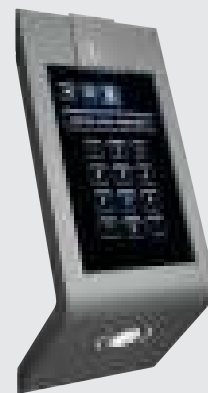

PORT Terminal with card reader

▶▶▶ Schindler's PORT Technology not only improves total time to destination by as much as 50%, it also reduces wait times by up to 50%. Improvement is realized in all traffic modes, including up peak, two way and down peak.

Freedom of design

Choose from our interior design options to create your own signature look. Combine elements to achieve the ambiance that fits your building's style.

Add personality to your elevator

Cars with distinction

We offer a wide range of decorative options for creating your own unique design to match your architectural concept and ideas. Mix and match colors, materials, lighting, mirrors, handrails and fixtures. Provide a unique ride experience with fresh colors, distinctive patterns, and high-quality materials. In some configurations, you can add as much as 50% of extra interior weight to the rated passenger load.

Versatile laminates and hung panels

Determine your modern look from warm or cool colors to create a fresh look or combine the options to enhance contrast for more depth. Choose from a standard selection of solid colors, textures, and woodgrain finishes to add distinctive features to any public, commercial or residential building.

From modern stainless to classic bronze designs

Choose from a variety of metal cab finishes, including:

- Stainless (brushed or mirrored)
- Bronze (brushed or mirrored)
- 5WL pattern.

Back painted glass panels

By putting color behind safety glass, you create a high gloss and vibrant effect that adds a pleasant ambiance to your car.

Glass doors and glass walls

Add eye-catching transparency to your car. The wide range of glass doors helps you to suit any application. Glass panels can either be installed on rear and side walls of the car for maximized visibility and security or they can be combined with other car interior materials. Frames for glass panels are available in three finishes.



Stainless steel



Glass walls

Working from our bare car option, you can design your own, totally custom car with materials and finishes of your own choosing.

Note: Specifications, options and colors are subject to change. All cars and options illustrated in this brochure are representative only. The samples shown may vary from the original in color and material.

Accessorize your elevator with style

Our car and landing operating panels and options, such as handrails, mirrors and lighting, suit your chosen styling to give your elevator the perfect finish — down to the smallest detail.

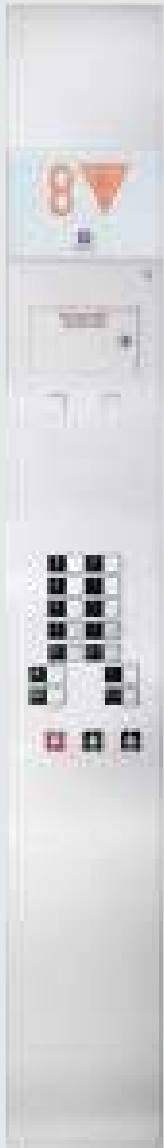

Car operating panel

Fixtures



Hall pushbuttons



Vandal-resistant hall pushbuttons

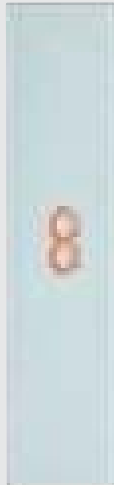

Hall lantern

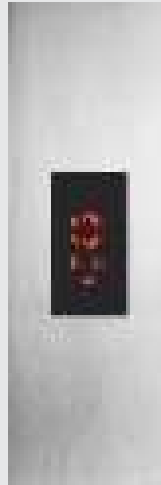

Vandal-resistant hall lantern

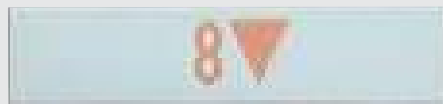

Horizontal landing indicator panel

Note: California Building Code compliant landing fixtures available. See 5500 MRL Fixtures Sheet.

Operating panels

Make your elevator easy to operate for all passengers - helping them locate the elevator and get to their selected destination comfortably. High resolution indicators are easy to read, and energy-efficient operating panels are made from high-quality materials with beautiful finishing options.

Mirrors

Mirrors always add a special sense of space to rooms and buildings. In order to give your car more appeal and depth, one sidewall or the rear wall can be provided with a full-height or half-height safety-glass mirror.

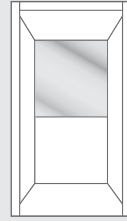

Half-height



Full-height



Full-height

Handrails

Handrails match the interior and layout of your car. They are available in stainless steel and bronze, and can be mounted to the side and rear walls.



Round handrail



Doors

Landing doors are available in stainless steel, bronze, and a variety of durable powder coat finishes. Variable frame sizes and welded and mitered frames allow you to match the design requirements of any building type. Doors can be configured as either center-opening or side-opening.

Lighting

A selection of four standard lighting options lets you add the right atmosphere to your elevator — from warm spot light to modern lighting designs.

You can choose from one of the lighting solutions that comes with our interior designs or you can opt for a custom solution.



LED round spot downlights

Green mobility

Keep energy consumption to a minimum by using power more efficiently. The new technological advances of the Schindler 5500, such as regenerative drives, new traction media, and carefully selected materials, ensure an ecologically sound solution.

From savings to sustainability

up to 30%



up to 20x

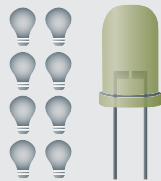

up to 50%



Clean drive technology

Thanks to high-efficiency regenerative drives the Schindler 5500 uses about 30% less energy than traditional elevators. With the clean PowerFactor 1 technology, the drives are even able to produce energy that can be fed back into the electricity grid immediately.

LED lighting

LED lights have an extremely long service life. They last up to 20 times longer than standard light bulbs while consuming less energy. A bright solution for passengers and the environment.

Optimized motor and traction media

Big in performance, compact in size. Efficient in travel, effective in energy usage. The new drive and traction configuration weighs up to 50% less than its predecessor while using less oil.

Energy-efficiency rating systems



Environmental responsibility

The Schindler 5500 is another leading example of our commitment to providing architects, contractors, building owners and managers with eco-friendly mobility solutions. In addition to energy-efficient performance features, we have developed responsible production systems and material usage while achieving faster, smoother installations.

What's more, Schindler is a member of the U.S. Green Building Council and can assist you in obtaining credits for certification through the LEED® Green Building Rating System.

Seamless connectivity

Made for today. Ready for the future.

With Schindler Ahead, we turn data into results for customers and passengers.

Schindler Ahead is a cloud platform, powered by GE Predix. Using 4G connectivity, this closed-loop digital platform allows your connected equipment to become part of the Building Internet of Things (IoT). Secure, automated data collection and real-time analytics provide insights that allow for predictive maintenance, equipment visibility, maximized uptime and more accurate capital planning. Building owners, facilities managers and passengers can have the relevant information they need, when they need it.

To learn more about Schindler Ahead, visit www.schindler.com/ahead-us.

Key benefits of Schindler Ahead



**Building Manager /
Owner / Developer**

**Facility Manager/
Administrator**

Passengers

- High reliability and uptime improves overall building performance
- Insights about component lifetime allow for better mid-term planning of repairs and modernizations
- Complete digital documentation of equipment portfolio
- 24/7 digital emergency service
- Increased building value by connecting to Internet of Things
- Cost-saving solutions with service guarantees and removal of phone line

- High reliability and uptime with fast reaction times, thanks to predictive maintenance
- Real-time information on equipment status and performance
- Push notifications via app, text, or email provide full transparency on status of maintenance activities

- Reduced wait times and increased reliability lead to potential improvements in the passenger experience
- Regular status updates about equipment and maintenance work via the app, text, or email
- Increased convenience thanks to interactive and personalized information

Need a Different Car or Hoistway Size?

The 5500 can be flexed to meet the requirements of your building. Contact your Schindler Representative for assistance.

Non-Seismic Layout Data

Load Capacity lbs (kg)	Cab Width	Cab Depth	Door Type ⁵	Door Width	Hoistway Width	Hoistway Depth	Pit Depth			Clear Overhead ⁸		
	ft-in (mm)	ft-in (mm)		ft-in (mm)	ft-in (mm)	ft-in (mm)	ft-in (mm)	ft-in (mm)	ft-in (mm)	ft-in (mm)	ft-in (mm)	ft-in (mm)
							200 fpm	350 fpm	500 fpm	200 fpm	350 fpm	500 fpm

General Purpose Side Counterweight

2100 (950)	5'-8 1/2" (1740)	4'-3 1/2" (1308)	2SSO	3' (914)	7'-10 1/2" (2400)	5'-7" (1702)	NA	5'-1" (1549)	5'-5" (1651)	5'-5" (1651)	13'-2" (4013)	13'-11" (4242)	13'-11" (4242)
2500 (1135)	6'-2 7/8" (1902)	4'-5 1/4" (1353)	2SSO	3'-6" (1067)	8'-6" (2591)	5'-9" (1753)	6'-6 1/4" (1988)	5'-1" (1549)	5'-5" (1651)	5'-5" (1651)	13'-2" (4013)	13'-11" (4242)	13'-11" (4242)
	6'-8 3/4" (2051)	4'-5 1/4" (1353)	SSCO	3'-6" (1067)	8'-11 1/8" (2721)	5'-6" (1676)	6'-0 1/4" (1835)	5'-1" (1549)	5'-5" (1651)	5'-5" (1651)	13'-2" (4013)	13'-11" (4242)	13'-11" (4242)
3000 (1360)	6'-2 7/8" (1902)	5'-3" (1600)	2SSO	3'-6" (1067)	8'-6" (2591)	6'-6 1/2" (1994)	7'-4" (2235)	5'-1" (1549)	5'-5" (1651)	5'-5" (1651)	13'-2" (4013)	13'-11" (4242)	13'-11" (4242)
	6'-2 7/8" (1902)	5'-3" (1600)	SSCO	3'-6" (1067)	8'-6" (2591)	6'-3 1/2" (1918)	6'-10 1/8" (2086)	5'-1" (1549)	5'-5" (1651)	5'-5" (1651)	13'-2" (4013)	13'-11" (4242)	13'-11" (4242)
3500 (1590)	6'-2 7/8" (1902)	5'-9" (1753)	2SSO ⁹	3'-6" (1067)	8'-6" (2591)	7'-0 1/2" (2146)	7'-10" (2388)	5'-7" (1702)	6'-1" (1854)	6'-1" (1854)	13'-2" (4013)	13'-11" (4242)	13'-11" (4242)
	6'-2 7/8" (1902)	5'-9" (1753)	SSCO	3'-6" (1067)	8'-6" (2591)	6'-9 1/2" (2070)	7'-4" ¹¹ (2235)	5'-7" (1702)	6'-1" (1854)	6'-1" (1854)	13'-2" (4013)	13'-11" (4242)	13'-11" (4242)
	6'-8 3/4" (2050)	5'-10 7/8" (1800)	SSCO ^{10,12}	3'-6" (1067)	8'-11 1/2" (2731)	7' (2134)	7'-6" (2286)	5'-7" (1702)	6'-1" (1854)	6'-1" (1854)	13'-2" (4013)	13'-11" (4242)	13'-11" (4242)
4000 (1815)	7'-0 5/8" (2150)	5'-9" (1753)	SSCO ¹²	4' (1219)	9'-5" (2870)	6'-9 1/2" (2070)	7'-4" (2235)	5'-11" (1803)	5'-11" (1803)	6'-5" (1956)	13'-2" (4013)	13'-11" (4242)	13'-11" (4242)

Hospital Service Side Counterweight

4000 (1815)	6'-0 1/2" (1842)	7'-2 5/8" (2200)	2SSO ¹²	4' ¹³ (1219)	8'-5" (2565)	8'-6" (2591)	9'-3 5/8" (2835)	5'-1" (1549)	5'-5" (1651)	5'-5" (1651)	13'-1" (3988)	13'-11" (4242)	14'-4" (4369)
4500 (2040)	6'-0 1/2" (1842)	7'-8 5/8" (2353)	2SSO ¹²	4' ¹³ (1219)	8'-5" (2565)	9' (2743)	9'-9 5/8" (2835)	5'-1" (1549)	5'-5" (1651)	5'-5" (1651)	13'-3" (4039)	14'-4" (4369)	14'-4" (4369)
5000 (2270)	6'-0 1/2" (1842)	8'-4 1/8" (2543)	2SSO ¹²	4' ¹³ (1219)	8'-5" (2565)	9'-8" (2946)	10'-5 1/2" (3188)	5'-8" (1727)	6'-1" (1854)	6'-1" (1854)	13'-9" (4181)	14'-4" (4369)	14'-4" (4369)
5000 AIA (2270)	5'-9" (1753)	9'-0 3/8" (2753)	2SSO ¹²	4' (1219)	8'-1 1/2" (2467)	10'-4" (3150)	11'-1 3/8" (3388)	5'-8" (1727)	6'-5" (1956)	6'-5" (1956)	13'-9" (4181)	14'-4" (4369)	14'-4" (4369)

General Purpose Rear Counterweight

2500 (1135)	7'-0 3/8" (2143)	4'-3 5/8" (1311)	2SSO	3'-6" (1067)	8'-6 3/8" (2600)	6'-6 5/8" (1972)	NA	5'-1" (1549)	5'-5" (1651)	5'-5" (1651)	15'-4" (4674)	16'-0" (4877)	16'-0" (4877)
	7'-0 3/8" (2143)	4'-3 5/8" (1311)	SSCO	3'-6" (1067)	8'-6 3/8" (2600)	6'-2 5/8" (1896)		5'-1" (1549)	5'-5" (1651)	5'-5" (1651)	15'-4" (4674)	16'-0" (4877)	16'-0" (4877)
3000 (1360)	7'-0 3/8" (2143)	4'-8 1/8" (1426)	2SSO ¹²	3'-6" (1067)	8'-6 3/8" (2600)	6'-10 1/8" (2086)		5'-1" (1549)	5'-5" (1651)	5'-5" (1651)	15'-4" (4674)	16'-0" (4877)	16'-0" (4877)
	7'-0 3/8" (2143)	4'-8 1/8" (1426)	SSCO	3'-6" (1067)	8'-6 3/8" (2600)	6'-7 1/4" (2013)		5'-1" (1549)	5'-5" (1651)	5'-5" (1651)	15'-4" (4674)	16'-0" (4877)	16'-0" (4877)
3500 (1590)	7'-0 3/8" (2143)	5'-4" (1626)	2SSO ¹²	3'-6" (1067)	8'-6 3/8" (2600)	7'-6" (2286)		5'-1" (1549)	5'-5" (1651)	5'-5" (1651)	15'-4" (4674)	16'-0" (4877)	16'-0" (4877)
	7'-0 3/8" (2143)	5'-4" (1626)	SSCO	3'-6" (1067)	8'-6 3/8" (2600)	7'-3 1/8" (2213)		5'-1" (1549)	5'-5" (1651)	5'-5" (1651)	15'-4" (4674)	16'-0" (4877)	16'-0" (4877)
4000 (1815)	8'-0 1/8" (2442)	5'-4" (1626)	SSCO ¹²	4' (1219)	9'-6 3/8" (2905)	7'-3 1/8" (2213)		5'-1" (1549)	5'-5" (1651)	5'-5" (1651)	15'-4" (4674)	16'-0" (4877)	16'-0" (4877)

Notes:

- All dimensions are for information only and cannot be used for construction purposes without Schindler confirmation. Contact your local Schindler Representative.
- Passenger car dimensions based on decoration weights that are 40% of the car's capacity. Service cars are based on side and rear walls with Schindler standard removable hung panels. Additional weight may impact pit and overhead dimensions.
- All dimensions are based on 8' tall cabs. 9' and 10' heights are also available.
- Doors are available in 7', 8', or 9' heights. Note that minimum floor to floor height must be at least 18" greater than the door height.
- If there is occupied or occupiable space below the hoistway, please contact your local Schindler Representative for dimensions.
- Horizontal tolerance for plumb hoistway is +/-1" for travel under 260', and +/-1.75" for travel over 260'. Over 260' of travel, dimensions will increase. Confirm with your local Schindler Representative.
- For configurations with remote control closet or machine room above, contact your Schindler Representative.

Seismic Layout Data 14

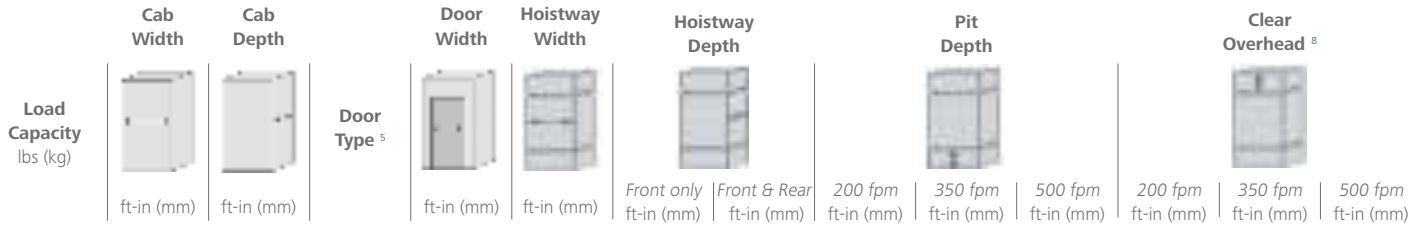

General Purpose Side Counterweight

Load Capacity	Cab Width	Cab Depth	Door Type	Door Width	Hoistway Width	Hoistway Depth	Pit Depth	Clear Overhead
2100 (950)	5'-8 1/2" (1740)	4'-3 1/2" (1308)	2SSO	3' (914)	8'-1" (2464)	5'-7" (1702)	NA	5'-1" (1549), 5'-5" (1651), 5'-5" (1651), 13'-2" (4013), 13'-9" (4181), 13'-11" (4242)
2500 (1135)	6'-2 7/8" (1902)	4'-5 1/4" (1353)	2SSO	3'-6" (1067)	8'-8 5/8" (2657)	5' 9" (1753)	6'-6 1/4" (1988)	5'-1" (1549), 5'-5" (1651), 5'-5" (1651), 13'-2" (4013), 13'-9" (4181), 13'-11" (4242)
	6'-8 3/4" (2051)	4'-5 1/4" (1353)	SSCO	3'-6" (1067)	9'-2 3/8" (2804)	5'-6" (1676)	6'-0 1/4" (1835)	5'-1" (1549), 5'-5" (1651), 5'-5" (1651), 13'-2" (4013), 13'-9" (4181), 13'-11" (4242)
3000 (1360)	6'-2 7/8" (1902)	5' 3" (1600)	2SSO	3'-6" (1067)	8'-8 5/8" (2657)	6'-6 1/2" (1994)	7'-4" (2235)	5'-1" (1549), 5'-5" (1651), 5'-5" (1651), 13'-2" (4013), 13'-9" (4181), 13'-11" (4242)
	6'-2 7/8" (1902)	5' 3" (1600)	SSCO	3'-6" (1067)	8'-9 1/8" (2670)	6'-3 1/2" (1918)	6'-10 1/8" (2086)	5'-1" (1549), 5'-5" (1651), 5'-5" (1651), 13'-2" (4013), 13'-9" (4181), 13'-11" (4242)
3500 (1590)	6'-2 7/8" (1902)	5'-9" (1753)	2SSO ⁹	3'-6" (1067)	8'-8 5/8" (2657)	7'-0 1/2" (2146)	7'-10" (2388)	5'-1" (1549), 5'-11" (1803), 5'-11" (1803), 13'-2" (4013), 13'-9" (4181), 13'-11" (4242)
	6'-2 7/8" (1902)	5'-9" (1753)	SSCO	3'-6" (1067)	8'-9 1/8" (2670)	6'-9 1/2" (2070)	7'-4" (2235)	5'-1" (1549), 5'-11" (1803), 5'-11" (1803), 13'-2" (4013), 13'-9" (4181), 13'-11" (4242)
	6'-8 3/4" (2050)	5'-10 7/8" (1800)	SSCO ^{10,12}	3'-6" (1067)	9'-2 3/4" (2813)	7'-0" (2134)	7'-6" (2286)	5'-1" (1549), 5'-11" (1803), 5'-11" (1803), 13'-2" (4013), 13'-9" (4181), 13'-11" (4242)
4000 (1815)	7'-0 5/8" (2150)	5'-9" (1753)	SSCO ¹²	4' (1219)	9'-8" (2946)	6'-9 1/2" (2070)	7'-4" (2235)	5'-5" (1651), 6' (1829), 6' (1829), 13'-2" (4013), 14'-0" (4267), 14'-0" (4267)

Hospital Service Side Counterweight

4000 (1815)	6'-0 1/2" (1842)	7'-2 5/8" (2200)	2SSO	4' ¹³ (1219)	8'-7" (2616)	8'-6" (2591)	9'-3 5/8" (2835)	5'-5" (1651)	6'-1" (1854)	6'-1" (1854)	13'-3" (4039)	13'-11" (4242)	15'-5" (4699)
4500 (2040)	6'-0 1/2" (1842)	7'-8 5/8" (2353)	2SSO	4' ¹³ (1219)	8'-7" (2616)	9'	9'-9 5/8" (2988)	6'-3" (1905)	6'-6" (1981)	6'-6" (1981)	13'-3" (4039)	14'-4" (4369)	15'-5" (4699)
5000 (2270)	6'-0 1/2" (1842)	8'-4 1/2" (2543)	2SSO	4' ¹³ (1219)	8'-7" (2616)	9'-8" (2946)	10'-5 1/2" (3188)	6'-5" (1956)	7'-2" (2185)	7'-2" (2185)	13'-9" (4191)	14'-4" (4369)	15'-5" (4699)
5000 AIA (2270)	5'-9" (1753)	9'-0 3/8" (2753)	2SSO	4' (1219)	8'-3" (2515)	10'-4" (3150)	11'-1 3/8" (3388)	6'-5" (1956)	7'-2" (2185)	7'-2" (2185)	13'-9" (4191)	14'-4" (4369)	15'-5" (4699)

General Purpose Rear Counterweight

2500 (1135)	7'-0 3/8" (2143)	4'-3 5/8" (1311)	2SSO	3'-6" (1067)	8'-7" (2616)	6'-6 5/8" (1997)	NA	5'-1" (1549)	5'-5" (1651)	5'-5" (1651)	15'-4" (4674)	16'-0" (4877)	16'-0" (4877)
	7'-0 3/8" (2143)	4'-3 5/8" (1311)	SSCO	3'-6" (1067)	8'-7" (2616)	6'-3 5/8" (1921)		5'-1" (1549)	5'-5" (1651)	5'-5" (1651)	15'-4" (4674)	16'-0" (4877)	16'-0" (4877)
3000 (1360)	7'-0 3/8" (2143)	4'-8 1/8" (1426)	2SSO ¹²	3'-6" (1067)	8'-7" (2616)	6'-11 1/8" (2112)		5'-1" (1549)	5'-5" (1651)	5'-5" (1651)	15'-4" (4674)	16'-0" (4877)	16'-0" (4877)
	7'-0 3/8" (2143)	4'-8 1/8" (1426)	SSCO	3'-6" (1067)	8'-7" (2616)	6'-8 1/8" (2035)		5'-1" (1549)	5'-5" (1651)	5'-5" (1651)	15'-4" (4674)	16'-0" (4877)	16'-0" (4877)
3500 (1590)	7'-0 3/8" (2143)	5'-4" (1626)	2SSO ¹²	3'-6" (1067)	8'-7" (2616)	7'-7" (2311)		5'-1" (1549)	5'-5" (1651)	5'-5" (1651)	15'-4" (4674)	16'-0" (4877)	16'-0" (4877)
	7'-0 3/8" (2143)	5'-4" (1626)	SSCO	3'-6" (1067)	8'-7" (2616)	7'-4" (2235)		5'-1" (1549)	5'-5" (1651)	5'-5" (1651)	15'-4" (4674)	16'-0" (4877)	16'-0" (4877)
4000 (1815)	8'-0 1/8" (2442)	5'-4" (1626)	SSCO ¹²	4' (1219)	9'-7" (2921)	7'-4" (2235)		5'-1" (1549)	5'-8" (1727)	5'-8" (1727)	15'-4" (4674)	16'-0" (4877)	16'-0" (4877)

Notes (continued):

- Clear overhead is measured from the top landing to the underside of the hoist beam. Overhead will increase 12" for each additional foot of cab height.
- Stretcher compliant with up to 1/2" of decoration thickness. For up to 1" of decoration thickness, additional hoistway width is required.
- This 3,500 lb car with CO doors fits an 84" stretcher with standard decoration (no hung panels).
- Dimensions based on front and rear entrances on the same side (passthrough). For cars with front and rear on different landings, contact your Schindler Representative.
- Configurations can accommodate an 84" stretcher.
- 4' 6" door also available.
- Seismic dimensions are based on Seismic Zone 4, and are only compliant with ASME A17.1 2010 code or greater. Dimensions may change for earlier code years, and final dimensions may vary based on your configuration.

Schindler 5500 Machine Room-Less (MRL) General Purpose and Hospital/Service

Capacity 2,100 – 5,000 lbs

Travel height Up to 350' and 33 stops, 45 openings

Speed 200 – 500 fpm

Cab height 8', 9', 10' (8' shown)

Plan view: counterweight on side

Single entrance (shown) or double entrance
Different door types possible (2SSO shown)

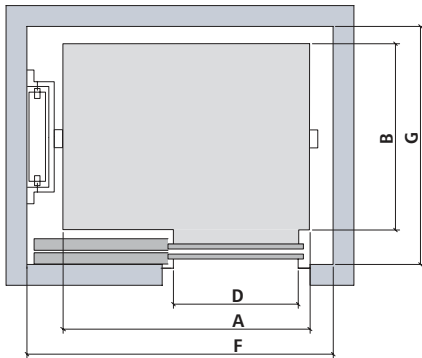

Plan view: counterweight on rear

Single entrance (shown)
Different door types possible (SSCO shown)

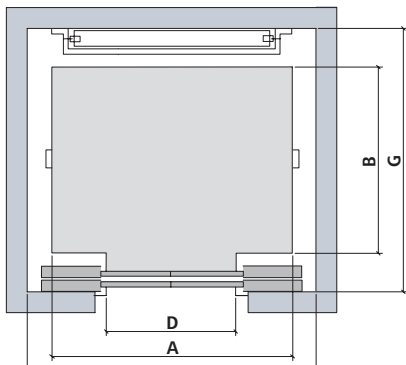

Vertical section*

Counterweight on side (shown) or rear
Single entrance (shown) or double entrance

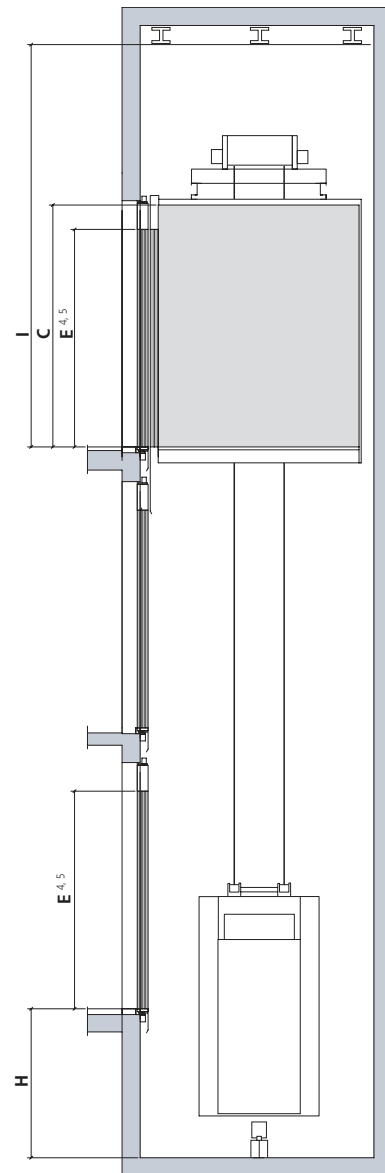

*Increasing overhead may reduce number of beams.

Abbreviations:

A Cab width	D Door width	G Hoistway depth
B Cab depth	E Door height	H Pit depth
C Car height	F Hoistway width	I Clear overhead

SSCO Single speed center opening door

2SSO Two speed side opening door

SchindlerPlan.com

Elevator and escalator design in minutes



Schindler Plan is an easy-to-use online planning tool that makes it simple to configure your elevator or escalator in minutes. Good elevator or escalator design plays a critical role in the quality of life and work in multi-story buildings. Schindler Plan was developed to enable accurate escalator or elevator preparation early in a project's life cycle.



Schindler – We Elevate

5500 CAPABILITIES BRO-WF3 1020

For more information, including the location of the Schindler office nearest you, please visit:

U.S. Headquarters. Morristown, New Jersey
Tel. 973.397.6500

www.us.schindler.com

Canada Headquarters. Toronto, Ontario
Tel. 416.332.8280

www.ca.schindler.com

We Elevate



Schindler has received renewal to ISO 9001 and ISO 14001 certificates.



Schindler prints with vegetable-based ink on paper containing post-consumer waste fiber.
© Schindler Elevator Corporation