

EM6400 series Multi-Function meters

- ① Digital display & Analog load bar indicators
- ② Bright Red LED display
- ③ Global: CE, UL marks
- ④ Universal



Demand
Monitoring



Quick and easy
installation



Turbo Key

Schneider
Electric™

EM6400 series Multi-Function meters

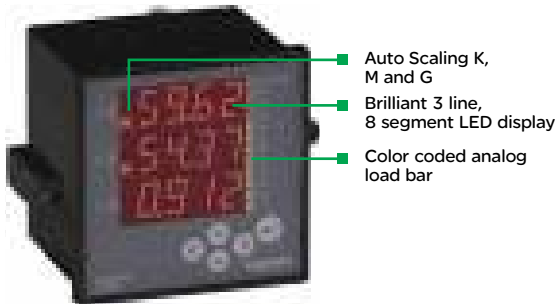

EM6400

- Auto Scaling K, M and G
- Brilliant 3 line, 8 segment LED display
- Color coded analog load bar



EM6459



EM6433

Features

EM6400 series meters are ideal replacements for analog meters. Use for standalone metering in custom panels, switch boards, switch gear, gensets, motor control centers and UPS systems.

Easy to use

- Fast setup via display or software

Measurements

- True RMS electrical parameters: per phase voltage, current, demand, W, VA, VAR
- Integrated parameters: kWh, kVARh, kVAh
- Neutral current, frequency, Power Factor, % Load, % Unbalance (V&I), Phase angle
- Onhours, Runhours & Interrupts.
- 4 Quadrant energy : bi-directional, absolute & net
- Demand: sliding & fixed block
- Options for Class 1.0, 0.5, 0.5S & CI 0.2 meters as per IEC 62052-11, IEC 62053-21, IEC 62053-22 & ANSI C112.20
- Total Harmonic Distortion (THD) measurement for both Voltage and Current circuit, per phase

Communications

- RS-485 port, Modbus RTU for integration with energy management systems

Certifications

- UL listed (US & Canada), CE, C-Tick certified

Front panel display

- Alpha numeric bright display
- Brilliant 3 line, 4 digit per line, (digit height 14 mm)
- LED display with auto-scaling capability for kilo, Mega, Giga
- View 3 parameters together
- Password protection for setup parameters
- User selectable default display page through keypad lock

Benefits

EM 6459

- Displays Volts, Amps, Frequency, PF simultaneously
- Monitors generator speed (RPM)
- Monitors generator loading efficiency
- ON hours & number of power interruptions

EM 6434

- Displays all power and energy parameters, Run hours, ON hours & number of power interruptions
- Monitors loading characteristics of motors

EM 6433

- Monitors active/apparent power & energy consumption, load current, Run hours, ON hours in a single meter
- Displays Amps, Power simultaneously

EM 6436

All benefits of EM 6433 and more

- Displays Volts, Amps, Frequency/PF simultaneously

EM 6400

All benefits of the above models and more

- Monitors all instantaneous, integrated and demand parameters
- Helps energy balancing

Applications

- Control Panels
- Motor Control Centers
- Power Distribution Panels
- Connection to Plant Monitoring & Control Systems
- Genset Panels
- Original Equipment Manufacturers (OEMs)
- Building Management System

User Programmable

- Delta / Star (Wye) / 2 Phase / 1 Phase
- PT, CT Ratios Primary & Secondary
- User selectable VAh/Wh (EM6436, EM6433)

Rugged Construction

Conforms to

Emission	: CISPR22
Fast Transient	: 4 kV IEC 61000-4-4
Surge withstand	: 4 kV IEC 61000-4-5
ESD	: 15 kV Air discharge, 8 kV Contact discharge IEC 61000-4-2
Impulse voltage	: 6kV, 1.2/50µSec, IEC 60060
Safety Construction	: Self extinguishable V0 plastic
Protection against	: Front IP 51 Rear IP 30

Technical Specification

Sensing/ Measurement	: True RMS, 1 sec update time 4 Quadrant Power & Energy
Accuracy	: Class 1.0 as per IEC 62052-11 and IEC 62053-21 Class 0.5 & 0.5S (optional) as per IEC 62052-11, 62053-22 and ANSIC12. 20 Class CI 0.2 (optional) as per IEC 62052-11 and IEC 62053-22
Aux Supply (Control Power)	: 44 to 300 Vac/dc
Input voltage	: 4 Voltage inputs (V1, V2, V3, VN) 110 or 415 Vac LL nominal(Range 80 to 600 Vac LL)
Input current (Energy Measurement)	: Current inputs (A1, A2, A3) 5 A Class 1.0 0.5: 5 mA (Starting) to 6 A* 5 A Class 0.5S 0.2: 5 mA (Starting) to 6 A 1 A Class 0.5S 0.2: 1 mA (Starting) to 1.2 A
Overload	: 5 A meter : 10 A max continuous 1 A meter : 2 A max continuous
Burden	: 0.2 VA max for each phase input voltage and current, 3 VA max on Aux Supply
Frequency	: 45 to 65 Hz
Resolution	: RMS 4 digit, INTG 8 digit
Communication	: RS 485 serial channel connection Industry standard Modbus RTU protocol
Isolation	: 2 kVac isolation for one min between all isolated circuits including communication port
Safety	: Measurement category III, Pollution Degree 2, Protection against shock by double insulation at user accessible area
Environmental	: Operating Temperature -10 °C to 60 °C (40 °F to 140 °F) Storage Temperature -25 °C to + 70 °C (-13 °F to 158 °F) Humidity 5% to 95% non condensing
Weight	: 400 gms approx. Unpacked 500 gms approx. Shipping

Note: * For 5 A universal meter additional error of 0.05% of full scale, for meter input current below 100 mA
For Class 0.5S and Class 0.2 meters, current inputs of 5A or 1A are factory set

Accuracy

Measurement	Accuracy % of Reading		
	CI 1.0	CI 5.5 /0.5S	CI 0.2
Volts LN per phase & Avg	1.0	0.5	0.2
Volts LL per phase & Avg	1.0	0.5	0.2
Amps per phase & Avg	1.0	0.5	0.2
Amps phase angle per phase	2°	1°	1°
Frequency	0.1	0.1	0.1
Active Power per phase & total	1.0	0.5	0.2
Reactive Power per phase & total	2.0	1.0	0.5
Apparent Power per phase & total	1.0	0.5	0.2
Active Energy Import/Export	1.0	0.5	0.2
Reactive Energy (Inductive/Capacitive)	2.0	1.0	0.5
Apparent Energy	1.0	0.5	0.2
RPM	1.0	0.5	0.2

Note: PF error limit is same as W error limit in %

Overload

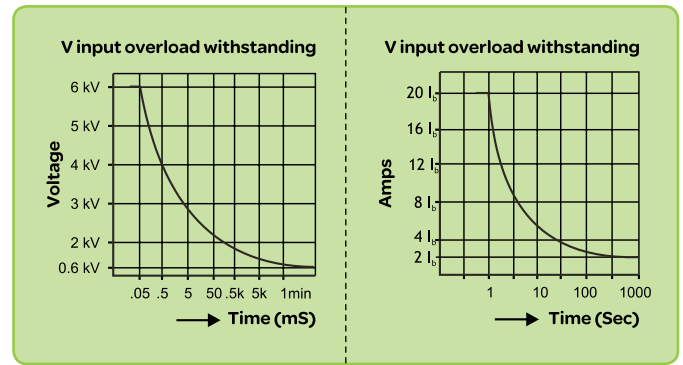

Models

v3.03

Parameter	EM 6459	EM 6433	EM 6434	EM 6436	EM 6400
V V1 V2 V3 V12 V23 V31				●	●
A A1 A2 A3	●	●		●	●
An Neutral Current	C				C
F	●			●	●
%Load					●
%A Unbal %V Unbal	●				●
PF PF1 PF2 PF3	●		●	●	●
%AFS Analog load bar	●	●	●	●	●
RPM	●				●
A Phase Angle A°1 A°2 A°3	●				●
W W1 W2 W3		⊙	●	⊙	●
VA VA1 VA2 VA3		⊙	●	⊙	●
VAR VAR1 VAR2 VAR3			●		●
nd VA/ W/ A					
Rising demand					DM
Time remaining					□
MD Maximum demand					
Hr MD occurred					
Wh		⊙	●	⊙	●
VAh		⊙	●	⊙	●
VARh			●		●
-VARh			●		●
Run hours		●	●	●	●
ON hours	●	●	●	●	●
INTR	●	●	●	●	●
R.Wh					
R.VAh					IE
R.VARh					□
-R.VARh					
Run hours					
Wh		⊙	●	⊙	●
VAh		⊙	●	⊙	●
VARh			●		●
-VARh			●		●
Run hours		●	●	●	●
R.Wh					
R.VAh					IE
R.VARh					□
-R.VARh					
Run hours					
V THD, per phase					●
Amps THD, per phase					●

Note: ● = Standard ■ = Option specified while ordering
C = Only through communication
⊙ = User selectable VAh/Wh through setup mode (EM 6436, EM 6433)

Communication Interface

RS 485 standard, communication capability using open Modbus RTU protocol. The meters can be multi-dropped using RS 485 twisted pair. The baud rate can be set from 1200 bps to 19200 bps. (Preferred settings is 9600 bps.)

RS 485 Half duplex isolated serial channel connection.

BMS Compatible

Access of either single (individual) parameter or block of parameters through RS 485 communication port. Integrates with BMS packages.

EM6400 meters are configurable with EGX gateway servers (EGX100, EGX300 etc.,)

EM6400 series meters can be directly configured with Schneider's Power Monitoring Expert (PME) or SPM or ION Enterprise Energy monitoring system softwares.

RS 485 Single Point
Communication Modbus



EM6400 meters can be interfaced through Modbus RTU protocol over RS-485 or TC/IP Ethernet network. Following schematic is for illustration only



Wiring Diagram

3 Phase 4 Wire Star (wye)

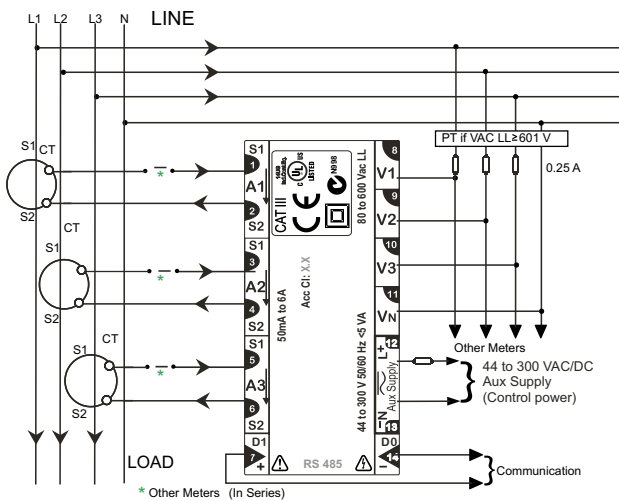

3 Phase 3 Wire Delta

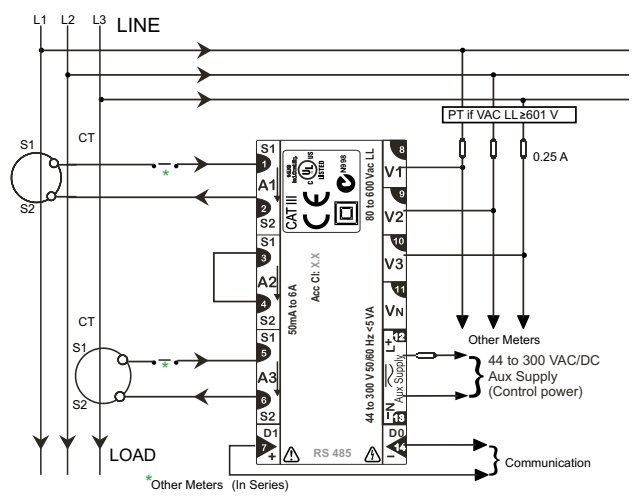

2 Phase 3 Wire

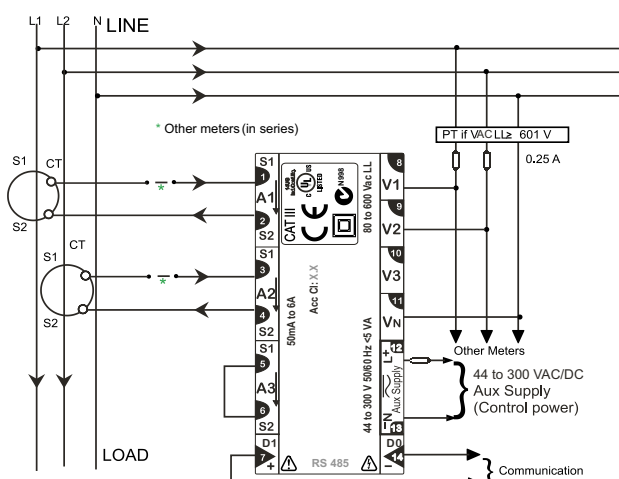

Single Phase

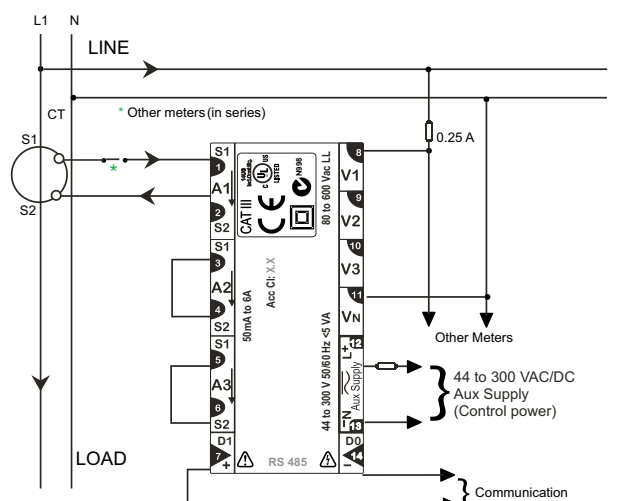

"3d" VA measurement

- EM 6400, EM 6433, EM 6436 is equipped with "3d VA Measurement" capability. This accurately include Distortion power (D) per IEEE 100, into the VA Calculation

$$\text{So, } VA_{3d} = \sqrt{W^2 + VAR^2 + D^2}$$

- However Arithmetic VA=VA1 +VA2+VA3 is also available as a set-up option

Demand Parameters Optional (for EM 6400 only)

- Monitors Demand - Present, Rising & Maximum, Time remaining
- VA or W or A demand is selectable through setup table
- User selectable demand interval through set up in steps of 5 minutes (5,10,15, 20, 25 & 30)
- Demand may be Sliding window (auto) or Fixed window (User), selectable through setup mode
- The time of occurrence for the Maximum Demand is based on " ON hrs" of the system
- Maximum Demand can be cleared independently or along with the integrators through the CLR function

Ordering Information

Specify

Model No.	RS485 COM Port
<input type="checkbox"/> EM 6459	
<input type="checkbox"/> EM 6433	<input checked="" type="checkbox"/> Built-in
<input type="checkbox"/> EM 6434	<input checked="" type="checkbox"/> Built-in
<input type="checkbox"/> EM 6436	<input type="checkbox"/>
<input type="checkbox"/> EM 6400 <input type="checkbox"/> Demand <input type="checkbox"/> Import/Export	<input type="checkbox"/>

Input Current	Accuracy
<input type="checkbox"/> 5A Universal	<input type="checkbox"/> CI 1.0 <input type="checkbox"/> CI 0.5
<input type="checkbox"/> 5A	<input type="checkbox"/> CI 0.5S <input type="checkbox"/> CI 0.2
<input type="checkbox"/> 1A	<input type="checkbox"/> CI 0.5S <input type="checkbox"/> CI 0.2

Integrated Parameters

- Import / Export is optional. Factory selectable on order (For EM 6400 only)
- Energy Parameter (kWh, kVAh, kVARh inductive and kVARh Capacitive) (Total, Import & Export)
- Separate Run hrs for Import, Export and Total
- Run hrs, ON hrs, No of interruptions

Terminals Description

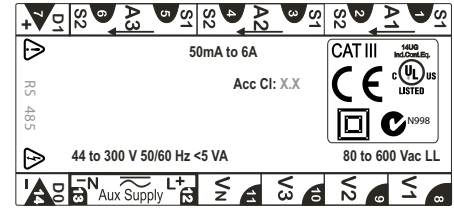

Dimensions

- Bezel : 96 x 96 mm
- Depth : 80 mm behind Bezel
- Panel cutout : 92^{+0.5}x92^{+0.5} mm

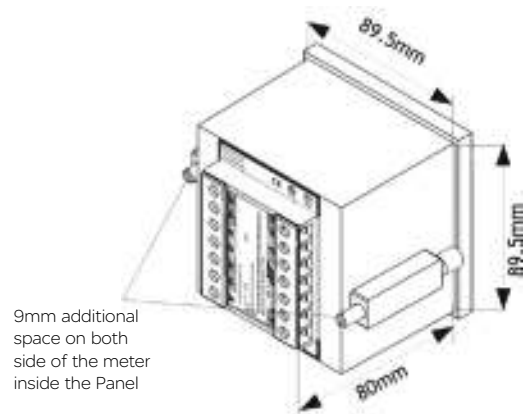

ION set up Software for Configuration

- A GUI based software tool for programming meters
- Downloadable from website



Make the most of your energySM

Schneider Electric India Pvt. Ltd.

Corporate office

9th Floor, DLF Building No.10, Tower C, DLF Cyber City,
Phase II, Gurgaon - 122002, Haryana
Tel: 0124 3940400, Fax: 0124 4222036
www.schneider-electric.com

Customer Care Centre :

Toll-free numbers: 1800 103 0011, 1800 425 4272
General number: 0124 4222040,
Email: customercare.in@schneider-electric.com

