

Low Voltage
Catalogue | 2013

Source changeover systems

Compact NSX100-630, Compact NS630b-1600,
Compact INS/INV, Masterpact





Efficient energy management and continuity of service with source-changeover system

To ensure continuity of service for critical applications, LV electrical installations need to be connected to at least **two independent power sources**:

① **A normal source (N)**

② **And a replacement source (R)***

used to supply energy to the installation when the normal source unavailable, or, for instance, when its quality and/or availability is no longer guaranteed.

The source-changeover system switches the load (partly or fully) between these two sources.

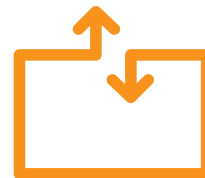

A few basics on source-changeover systems

> A source-changeover system **can be automated to manage transfers according to external conditions.**

> Switching from a main power source to a replacement source **can be performed either manually or automatically.**

> A source-changeover system **comprises circuit breakers, switch-disconnectors or contactors.**

* The replacement source (R) can be: a second power source (with possibly different characteristics from the normal source) or an electrical generator

3 ways to switch the load to meet your needs

1

Manual source-changeover system

(or MTSE: Manual Transfer Switching Equipment)

The simplest way to switch the load. It is controlled manually by an operator. The time required to switch from the 'N' source to 'R' source can vary.



System

2 or 3 mechanically interlocked manually-operated circuit breakers or 2 switch-disconnectors.

Applications

Buildings and infrastructure where the need for continuity of service is significant but not a priority: offices, small and medium-sized businesses.

2

Remote-operated source-changeover system

(or RTSE: Remote Transfer Switching Equipment)

The most commonly used system for devices with high ratings. No direct human intervention is required. Source-changeover is controlled electrically.



System

2 or 3 circuit breakers that may have different configurations, linked by an electrical interlocking system. In addition, a mechanical interlocking system protects against electrical malfunctions or incorrect manual operations.

Applications

Industry (assembly lines, engine rooms on ships, critical auxiliaries in thermal powerstations, etc.); **Infrastructure** (port and railway installations, runway lighting systems, control systems on military sites, etc.).

3

Automatic source-changeover system

(or ATSE: Automatic Transfer Switching Equipment)

An automatic controller may be added to a remote-operated source-changeover system. It is possible to automatically control source transfer according to programmed (dedicated controllers) or programmable (PLC) operating modes. These solutions ensure optimum energy management.



System

2 or 3 circuit breakers that may have different configurations, linked by an electrical interlocking system. A mechanical interlocking system protects against electrical malfunctions or incorrect manual operations, with an automatic control system (dedicated controllers or PLC).

Applications

Commercial and service sector (operating rooms in hospitals, safety systems for buildings, computer rooms for banks and insurance companies, lighting and emergency lighting systems in malls, etc.), **industry and infrastructure.**

Whatever the system, you benefit from our expertise!

> MTSE range



Compact INS
From 40 A to 630 A

> RTSE range

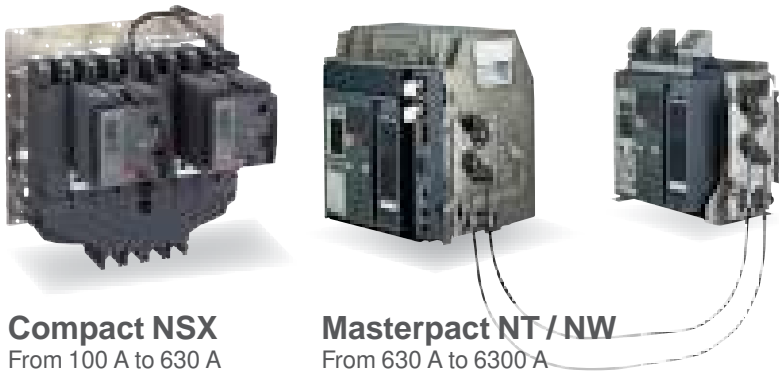

Compact NSX
From 100 A to 630 A

Masterpact NT / NW
From 630 A to 6300 A

> ATSE range



UA Controller **Compact NSX**
From 100 A to 630 A



Our expertise and support come together with the source-changeover system you choose for your LV electrical installation.

With Compact INS, Compact NSX and Masterpact NT and NW, we offer a complete range of solutions, designed around key values:

Maximum continuity of service

- > Energy availability is ensured whatever the external requirements (e.g. high power demand).
- > Maintenance and replacement of the sources (N or R) can be done with no interruption of service.

You can maintain a continuous level of service and customer satisfaction.

Maximum safety

For LV electrical installations where safety and continuity of service are critical for people and/or equipment such as hospitals, airports, banks, malls, etc.

Optimized energy management

- > Transfer the load to a replacement source according to external requirements.
 - > Manage power sources according to power quality and power costs.
 - > Perform system regulation.
 - > Switch to an emergency replacement source.
- You are no longer dependent on your power supply (and supplier)!

Simplicity and reliability

- > **Simple installation** on LV switchboard.
- > **Optimized size** of the switchboard.
- > System **based on pre-tested components**.
- > Compliance with **IEC 60947-6-1**.



For critical applications
in particular
For all others
in general

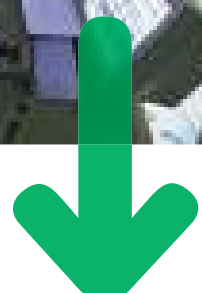
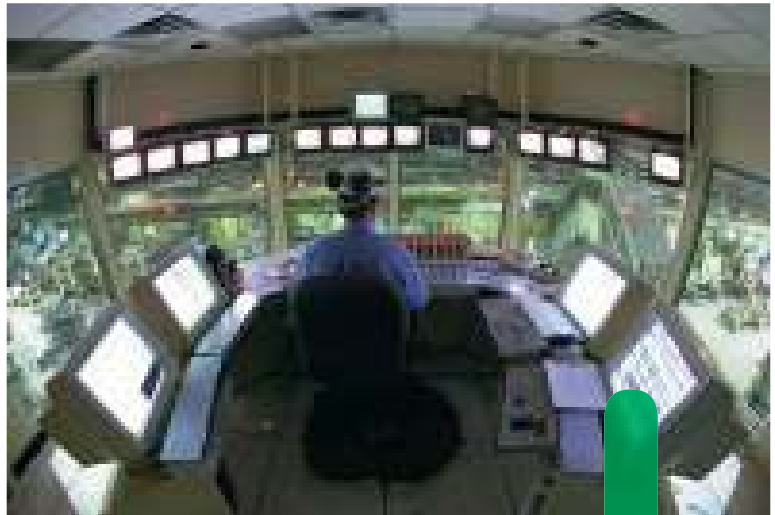

A source-changeover system is indispensable for applications that need a continuous supply of electric power (hospitals, airports, banks, government facilities, etc.).

But a source-changeover system is also suitable for all LV electrical installations exposed to:

- > Nominal voltage loss or dip (when there is high demand for electric power)
- > Unpredictable power quality
- > Frequent power cuts.

These factors, and many others, can damage the continuity of service of your electrical installation.

For infrastructure managers, a source-changeover system gives direct economic benefits: it is possible to select your source based on power cost.

In this case, the replacement source (R) is used as an alternative, more economical source.

Managing energy efficiently

Power Cost

Safety

| | |
|--------------|---|
| Presentation | 2 |
|--------------|---|

| | |
|-------------------------------|-----|
| Functions and characteristics | A-1 |
|-------------------------------|-----|

| | |
|------------|-----|
| Dimensions | B-1 |
|------------|-----|

| | |
|---------------------|-----|
| Electrical diagrams | C-1 |
|---------------------|-----|

| | |
|--------------------------------------|-----|
| Catalogue numbers and order forms | D-1 |
|--------------------------------------|-----|

For maximum continuity of service...

Incoming feeders and main LV switchboards



Currents
From 630 to 6300 A.

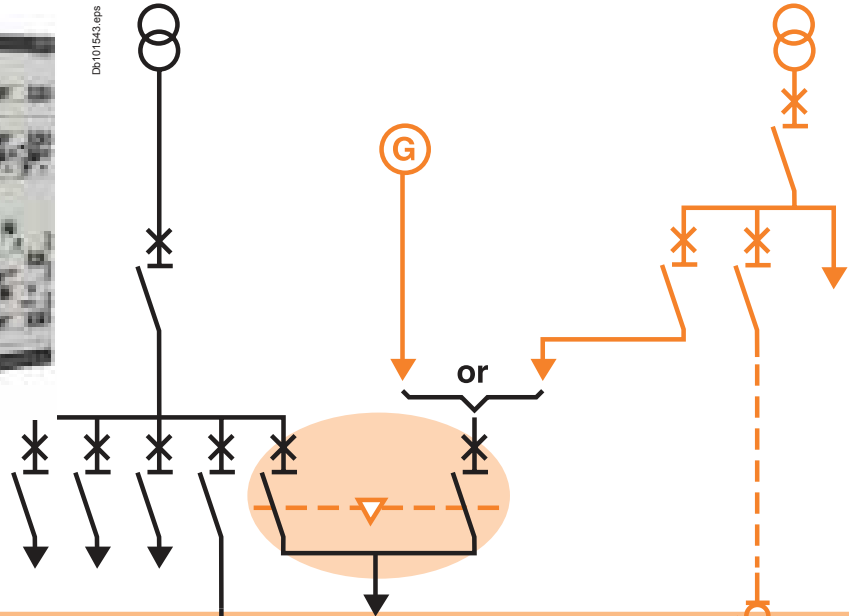

Power distribution



Currents
From 250 to 3200 A.

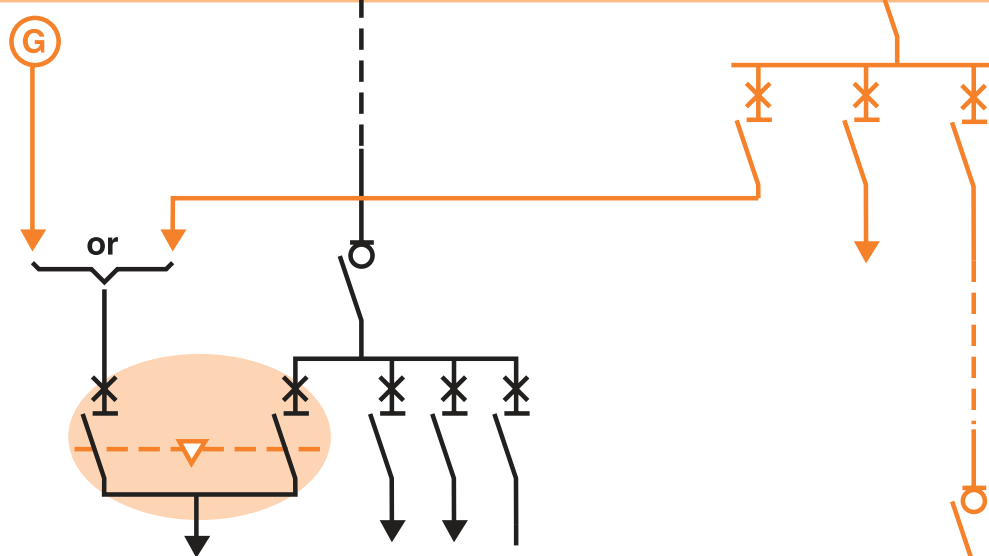

Loads



Currents
From 40 to 400 A.

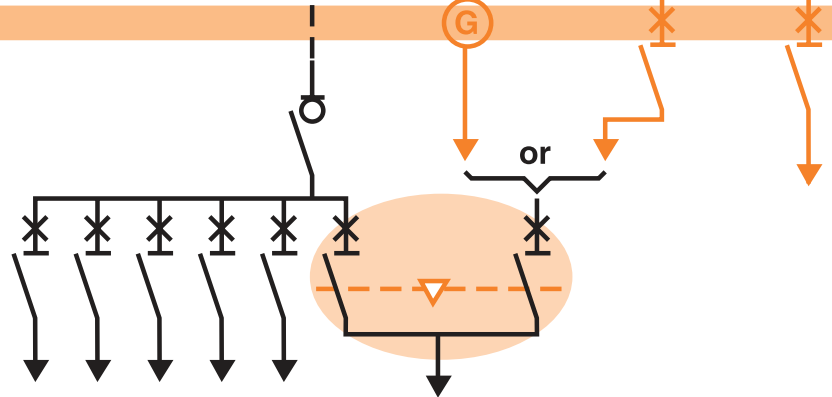

... in a wide range of applications

1 normal source
1 replacement source

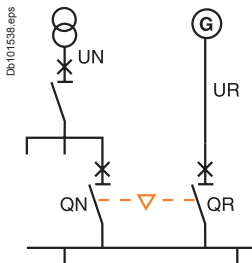

| QN | QR |
|----|----|
| 0 | 0 |
| 1 | 0 |
| 0 | 1 |

2 sources with coupler on busbars

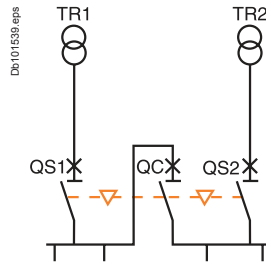

| QS1 | QC | QS2 |
|-----|----|------------------|
| 0 | 0 | 0 |
| 1 | 0 | 1 |
| 1 | 1 | 0 |
| 0 | 1 | 1 |
| 1 | 0 | 0 ⁽¹⁾ |
| 0 | 0 | 1 ⁽¹⁾ |

⁽¹⁾ possible by forcing source operation.

2 normal sources
1 replacement source

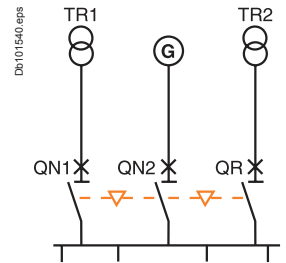

| QN1 | QN2 | QR |
|-----|-----|----|
| 0 | 0 | 0 |
| 1 | 1 | 0 |
| 0 | 0 | 1 |
| 1 | 0 | 0 |
| 0 | 1 | 0 |

Generator or permanent source

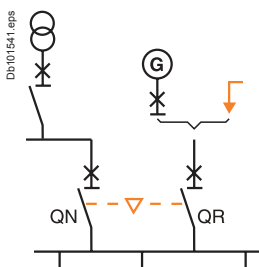

| QN | QR |
|----|----|
| 0 | 0 |
| 1 | 0 |
| 0 | 1 |

Typical applications:

- continuous production processes
- operating rooms
- computer rooms...

Generator or permanent source

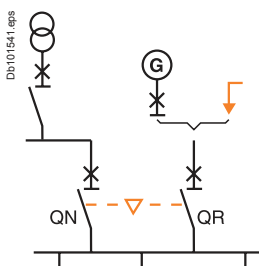

Generator or permanent source

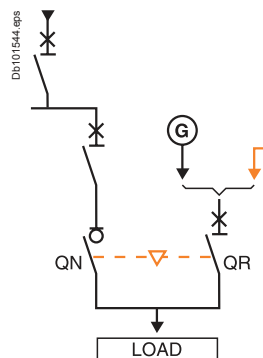

| QN | QR |
|----|----|
| 0 | 0 |
| 1 | 0 |
| 0 | 1 |

Typical applications:

- large electrical installations (e.g. airports)
- refrigeration units
- special electricity tariffs
- pumping stations...

Ecodial

Ecodial software is dedicated to LV electrical installation calculation in accordance with the IEC60364 international standard or national standards.

This 4th generation, "Ecodial Advance Calculation 4", offers a new ergonomic and new features:

- operating mode that allows easy calculation in case of installation with different type of sources (parallel transformers, back-up generators...)
- discrimination analysis associating curves checking and discrimination tables
- direct access to protection settings including residual current protections
- easy selection of alternate solutions or manual selection of a product.

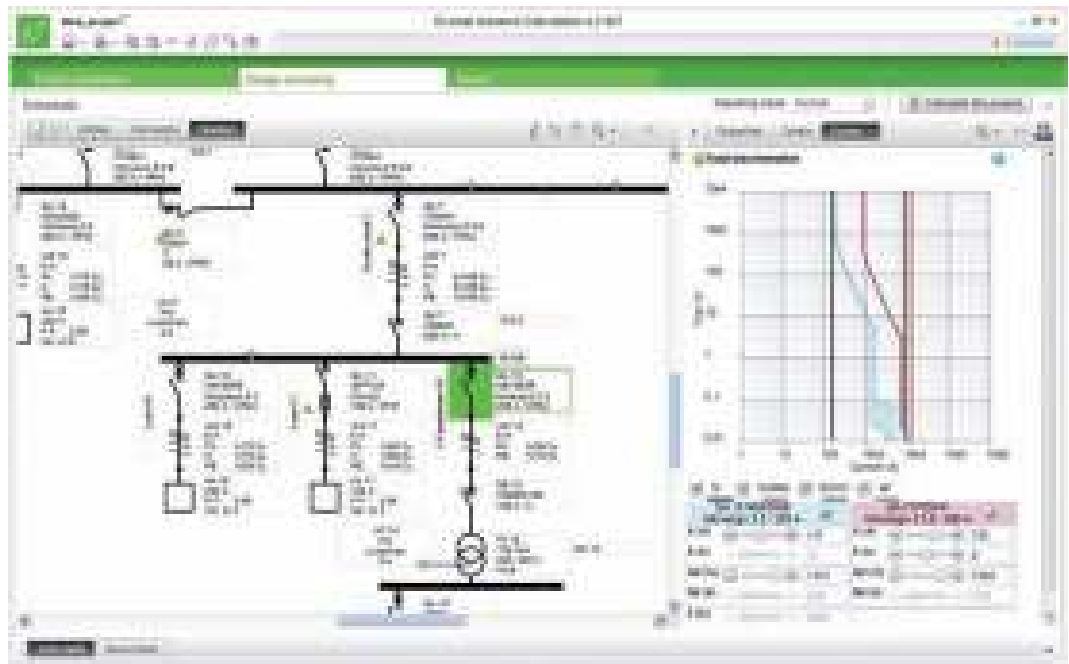

| | |
|--|-------------|
| <i>Presentation</i> | 2 |
| Overview of solutions | |
| Manual source-changeover systems Compact INS/INV 40 to 630 A, Compact NSX100/630 | A-2 |
| Manual source-changeover systems Compact NS and Masterpact NT/NW 630 A to 6300 A | A-3 |
| Remote-operated source-changeover systems Compact NSX100/630, Compact NS630b/1600 A | A-4 |
| Remote-operated source-changeover systems Masterpact NT/NW 630 A to 6300 A | A-5 |
| Manual source-changeover systems | |
| Possible combinations | A-6 |
| Remote-operated source-changeover systems | |
| Mechanical interlocking Compact NSX, Compact NS or Masterpact NT/NW | A-10 |
| Mechanical interlocking Compact NS or Masterpact NT/NW | A-11 |
| General characteristics Compact NSX | A-12 |
| General characteristics Compact NS, Masterpact NT/NW | A-13 |
| Mech. and elect. durability | A-14 |
| Connection and insulation accessories for Compact NSX and INS ≤ 630 A | A-15 |
| Electrical interlocking | A-16 |
| Standard configurations | A-17 |
| Associated controllers | |
| Controller selection | A-18 |
| Controller installation | A-19 |
| BA controller | A-20 |
| BA controller, Operating sequences | A-21 |
| UA controller | A-22 |
| UA controller, Operating sequences, Forced operation mode | A-23 |
| UA controller, Operating sequences, Special-tariff mode | A-24 |
| UA controller, Operating sequences, Test mode and automatic operation | A-25 |
| Operating sequences | |
| IVE unit | A-26 |
| BA/UA controller | A-27 |
| COM communications option | A-28 |
| <i>Dimensions</i> | <i>B-1</i> |
| <i>Electrical diagrams</i> | <i>C-1</i> |
| <i>Catalogue numbers and order forms</i> | <i>D-1</i> |

| Range | Compact | | Compact |
|----------------|---|--------------------------------------|---|
| Models | INS40 to INS80 INS100 to INS160 | INS250 to INS630 INV250 to INV630 | NSX100 to NSX250 NSX400 to NSX630 |
| Rating (A) | 40 to 160 | 100 to 630 | 100 to 630 |
| Type of device | Switch-disconnectors with extended handles | Switch-disconnectors | N/H/L circuit breakers NA switch-disconnectors |

Manual source-changeover systems

Interlocking via toggles

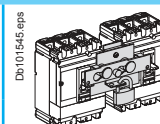
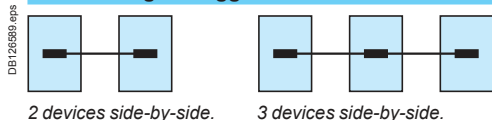

Interlocking via rotary handles

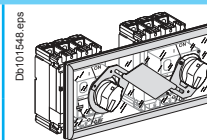
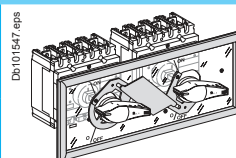
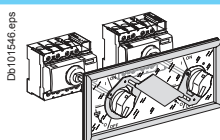
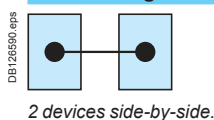

Interlocking via keylocks with captive keys

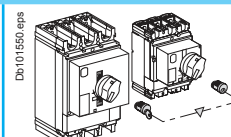
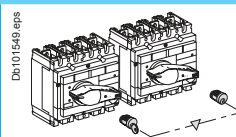
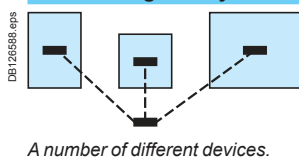

Interlocking on a base plate

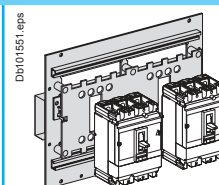
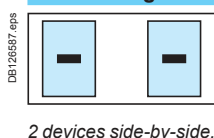

Complete source-changeover assemblies

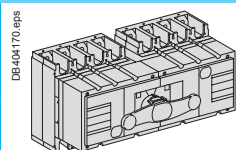
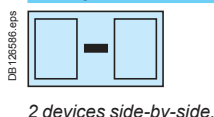

Manual source-changeover systems

Compact NS and Masterpact NT/NW 630 A to 6300 A

| Range | Compact | Masterpact | |
|----------------|---|---|--|
| Models | NS630b to NS1600 | NT06 to NT16 | NW08 to NW63 |
| Rating (A) | 630 to 1600 | 630 to 1600 | 800 to 6300 |
| Type of device | N/H/L circuit breakers NA switch-disconnectors | H1/L1 circuit breakers HA switch-disconnectors | N1/H1/H2/H3/L1 circuit breakers NA/HA/HF switch-disconnectors |

Manual source-changeover systems

Interlocking via extended rotary handles

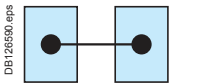

2 devices side-by-side.

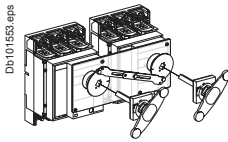

Interlocking via keylocks with captive keys

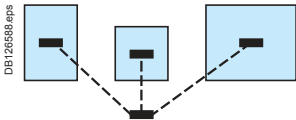

A number of different devices.

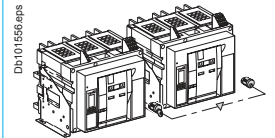
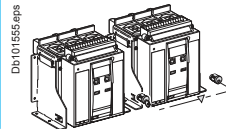
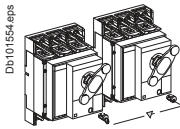

Mechanical interlocking using connecting rods

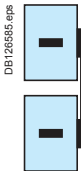

2 devices one above the other.

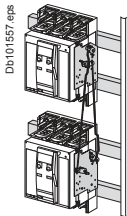

(1)

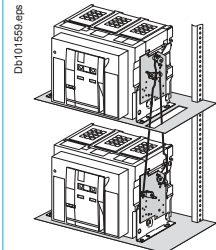
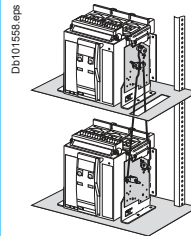

Mechanical interlocking using cables

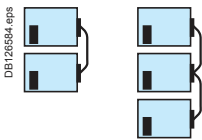

2 or 3 devices one above the other.

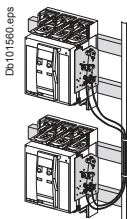

(1)

(2)

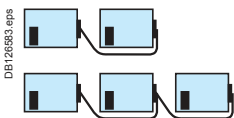
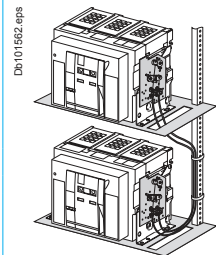
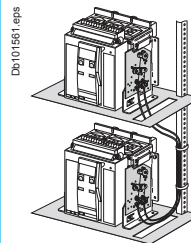

2 or 3 devices side-by-side.

For this case and other cases, please consult us

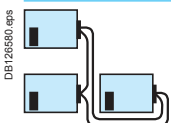

(1) Implemented with NS630b to NS1600 electrically-operated devices only.

(2) For source-changeover systems using cables, always respect the installation conditions specified on [page A-13](#).

| Range | Compact | |
|----------------|---|---|
| Models | NSX100 to NSX630 | NS630b to NS1600 |
| Rating (A) | 100 to 630 | 630 to 1600 |
| Type of device | N/H/L circuit breakers NA switch-disconnectors | N/H/L circuit breakers NA switch-disconnectors |

Remote-operated source-changeover system

Mechanical interlocking on base plate + electrical interlocking

DB126587.eps

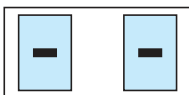

2 electrically-operated devices side-by-side combined with an electrical interlocking system.

DB101563.eps

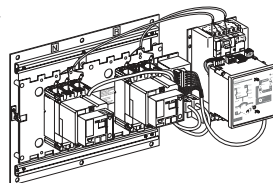

Mechanical interlocking using connecting rods + electrical interlocking

DB126585.eps



2 electrically-operated devices one above the other combined with an electrical interlocking system.

DB101587.eps

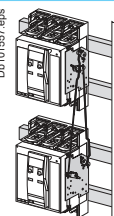

Mechanical interlocking using cables + electrical interlocking

DB126581.eps



2 electrically-operated devices one above the other combined with an electrical interlocking system.

DB126582.eps

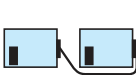

2 electrically-operated devices side-by-side combined with an electrical interlocking system.

DB101560.eps

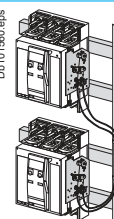

(1)

Automatic source-changeover systems

Remote-operated source-changeover system combined with an automatic-control system

DB126581.eps



The automatic controller operates the devices depending on external parameters.

BA: Simple controller that manages the changeover function.

UA: Controller that also manages engine generator sets.

UA150: UA controller with a communication option.

DB404439.eps

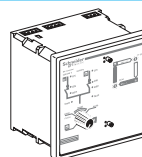

BA controller

DB404440.eps

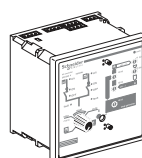

UA and UA150 controller

(1) For source-changeover systems using cables, always respect the installation conditions specified on [page A-13](#).

Remote-operated source-changeover systems Masterpact NT/NW 630 A to 6300 A

| Range | Masterpact | |
|----------------|---|--|
| Models | NT06 to NT16 | NW08 to NW63 |
| Rating (A) | 630 to 1600 | 800 to 6300 |
| Type of device | H1/L1 circuit breakers HA switch-disconnectors | N1/H1/H2/H3/L1 circuit breakers NA/HA/HF switch-disconnectors |

Remote-operated source-changeover system

Mechanical interlocking using connecting rods + electrical interlocking

DB126585.eps

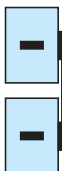

2 electrically-operated devices side-by-side combined with an electrical interlocking system.

DB101558.eps

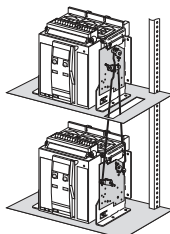

DB101559.eps

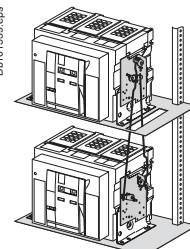

Mechanical interlocking using cables + electrical interlocking

DB126584.eps

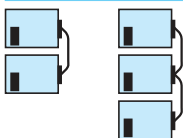

2 or 3 electrically-operated devices one above the other combined with an electrical interlocking system⁽¹⁾.

DB126583.eps

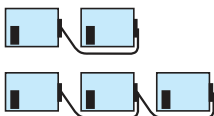

2 or 3 electrically-operated devices side-by-side combined with an electrical interlocking system⁽¹⁾.

DB101561.eps

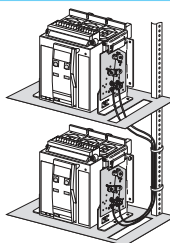

DB101562.eps

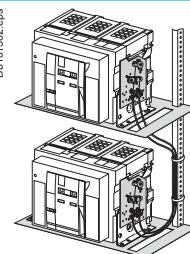

(2)

Automatic source-changeover systems

Remote-operated source-changeover system combined with an automatic-control system

DB126581.eps



The automatic controller operates the devices depending on external parameters.

BA: Simple controller that manages the changeover function.

UA: Controller that also manages engine generator sets.

UA150: UA controller with a communication option.

DB126582.eps



DB40439.eps

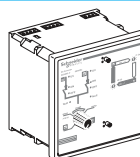

BA controller

DB40440.eps

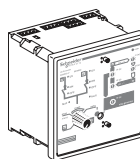

UA and UA150 controller

(1) Three devices with Masterpact NW only.

(2) For source-changeover systems using cables, always respect the installation conditions specified on page A-13. For other cases, please consult us.

Manual source-changeover systems

Possible combinations

A manual source-changeover system can be installed on two or three manually-operated and mechanically interlocked circuit breakers or switch-disconnectors. Interlocks prevent connection to both sources at the same time, even momentarily.

All possibilities for manual source-changeover systems

| Type of device | Type of interlocking for two devices | | | |
|-------------------------------------|--------------------------------------|---------|----------------------|------------------------|
| | Complete assembly | Keylock | Direct rotary handle | Extended rotary handle |
| Compact switch-disconnectors | | | | |
| INS40 to INS160 | | | | ■ |
| INS250-100 to INS630 | ■ | ■ | ■ ▲ | ■ ▲ |
| INV100 to 630 | | ■ | ■ ▲ | ■ ▲ ▲ |
| INS/INV630b to 2500 | | ■ | | |

Legend:

▲ Possible but visible break function disabled.

▲ 250 A and 630 A ratings can be mixed by using INS320/630 rotary handle interlocking system.

| Type of device | Type of interlocking for two devices | | | | | |
|---|--------------------------------------|---------|----------------------|------------------------|--|---------------------------------|
| | Toggle | Keylock | Direct rotary handle | Extended rotary handle | On base plate (toggle or direct extended rotary control) | On base plate (motor mechanism) |
| Compact fixed or withdrawable circuit breakers | | | | | | |
| NSX100 to 250 | ■ ■ | ■ ■ ● | ■ ■ | ■ ■ | ■ ■ ■ | ■ ■ ■ |
| NSX400 to NS630 | ■ ■ | ■ ■ ● | ■ ■ | ■ ■ | ■ ■ ■ | ■ ■ ■ |
| NSX100 to 630 | | ■ ■ ● | ■ ■ ● | ■ ■ ● | ■ ■ ■ ● | ■ ■ ■ ● |
| NS630b to 1600 with rotary handle | | ■ ■ ● | ■ ■ | ■ ■ | | |

Legend:

■ Fixed devices only.

■ Fixed or withdrawable devices.

■ Devices must be either both fixed or both withdrawable.

● With NSX400/630 rotary handle interlocking system.

● Possible with NSX400/630 base plate + NSX100-250 adaptation kit.

● Devices equipped with rotary handles.

| Type of device | Type of interlocking for either all fixed or all withdrawable devices | | | | | |
|--|---|------------------------------------|------------------------------------|---|---|---------------------------------------|
| | Keylock | Cable-type, 2 devices side-by-side | Cable-type, 3 devices side-by-side | Cable-type, 2 devices one above the other | Cable-type, 3 devices one above another | Rod-type, 3 devices one above another |
| Compact fixed or withdrawable circuit breakers or switch-disconnectors, with motor mechanism | | | | | | |
| NS630b to 1600 | ■ | ■ | | ■ | | ■ |
| Masterpact fixed or withdrawable circuit breakers or switch-disconnectors, manual operation or with motor mechanism | | | | | | |
| NT06 to 16 | ■ | ■ | | ■ | | ■ |
| NW08 to 63 | ■ | ■ | ■ | ■ | ■ | ■ |
| NT06 to NW63 | ■ | ■ | | ■ | | |

Possible combinations

Complete source-changeover assembly for two switch-disconnectors

All possibilities for manual source-changeover systems

DB404170.eps

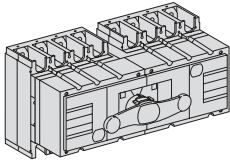

These assemblies provide an easy way to implement source changeover functions with:

- a single 3-position rotary handle that controls the two switch-disconnectors (Normal source ON, OFF, Replacement source ON)
- a smaller size, taking up less room in the switchboard.

A complete source changeover assembly can be ordered with a single catalogue number.

| "Normal N" | "Replacement" R | | | | | | | |
|-------------------|-----------------|------------|------------|------------|--------|--------|--------|--------|
| | INS250-100 | INS250-160 | INS200-200 | INS250-250 | INS320 | INS400 | INS500 | INS630 |
| INS250-100 | | | | | | | | |
| Ratings 100 A | ■ | | | | | | | |
| INS250-160 | | | | | | | | |
| Ratings 160 A | | ■ | | | | | | |
| INS200-200 | | | | | | | | |
| Ratings 200 A | | | ■ | | | | | |
| INS250-250 | | | | | | | | |
| Ratings 250 A | | | | ■ | | | | |
| INS320 | | | | | | | | |
| Ratings 320 A | | | | | ■ | | | |
| INS400 | | | | | | | | |
| Ratings 400 A | | | | | | ■ | | |
| INS500 | | | | | | | | |
| Ratings 500 A | | | | | | | ■ | |
| INS630 | | | | | | | | |
| Ratings 630 A | | | | | | | | ■ |

Interlocking of two or three toggle-controlled devices

Possible combinations of "Normal" and "Replacement" source circuit breakers

DB101656.eps

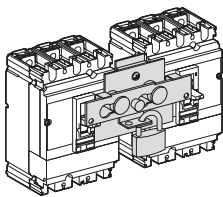

Two devices can be interlocked using this system. Two identical interlocking systems can be used to interlock three devices installed side by side, in which case one device is in the ON position and the two others are in the OFF position. Devices must all have the same configuration, i.e. fixed, plug-in, withdrawable or drawout.

The system is locked using one or two padlocks (shackle diameter 5 to 8 mm).

Two interlocking system models are available for:

- Compact NSX100 to 250
- Compact NSX400 to 630.

| "Normal N" | "Replacement" R | | | | |
|----------------------|-----------------|--------|--------|--------|--------|
| | NSX100 | NSX160 | NSX250 | NSX400 | NSX630 |
| NSX100 | | | | | |
| Ratings 16... 100 A | ■ | ■ | ■ | ■ | ■ |
| NSX160 | | | | | |
| Ratings 80... 160 A | ■ | ■ | ■ | ■ | ■ |
| NSX250 | | | | | |
| Ratings 125... 250 A | ■ | ■ | ■ | ■ | ■ |
| NSX400 | | | | | |
| Ratings 150... 400 A | ■ | ■ | ■ | ■ | ■ |
| NSX630 | | | | | |
| Ratings 630 A | ■ | ■ | ■ | ■ | ■ |

Manual source-changeover systems

Possible combinations

Interlocking of a number of devices using keylocks (captive keys)

Combination of "Normal" and "Replacement" devices

Dn1019568.eps

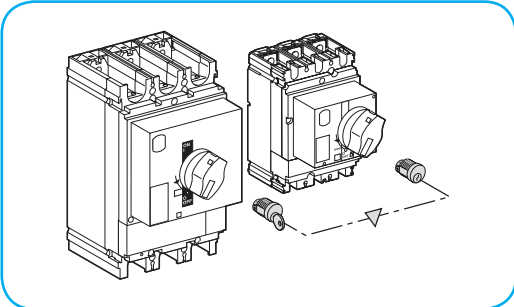

All Compact and Masterpact circuit breakers and Compact switch-disconnectors from 100 to 6300 A with rotary handles or motor mechanisms can be interlocked.

Interlocking is based on two identical keylocks with a single key and a keylock adapter (different for each device). This solution enables interlocking between two devices that are physically distant or that have very different characteristics, for example between a low and a medium-voltage device, or between Compact NSX circuit breakers and switch-disconnectors.

A system of wall-mounted captive key boxes makes possible a large number of combinations between many devices.

Interlocking of two devices with rotary handles

Possible combinations of "Normal" and "Replacement" source circuit breakers

Dn1019568.eps

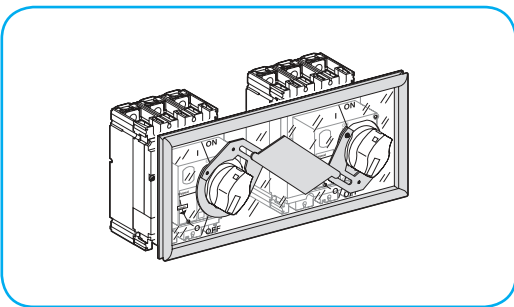

The direct or extended rotary handles are padlocked with the devices in the OFF position. The mechanism prevents simultaneous closing of the devices, but allows them to be opened.

| "Normal N" | "Replacement" R | | | | | |
|----------------------|-----------------------------------|--------|--------|--------|--------|--------|
| | Compact NSX100/630 ⁽¹⁾ | NSX100 | NSX160 | NSX250 | NSX400 | NSX630 |
| NSX100 | | | | | | |
| Ratings 16... 100 A | ■ | ■ | ■ | □ | □ | |
| NSX160 | | | | | | |
| Ratings 80...160 A | ■ | ■ | ■ | □ | □ | |
| NSX250 | | | | | | |
| Ratings 125...250 A | ■ | ■ | ■ | □ | □ | |
| NSX400 | | | | | | |
| Ratings 160... 400 A | □ | □ | □ | ■ | ■ | |
| NSX630 | | | | | | |
| Ratings 630 A | □ | □ | □ | ■ | ■ | |

□ 250 A and 630 A ratings can be mixed by using NSX400/630 rotary handle interlocking system.

| "Normal N" | "Replacement" R | | | | | |
|-----------------------|------------------------------------|--------|-------|--------|--------|--------|
| | Compact NS630b/1600 ⁽¹⁾ | NS630b | NS800 | NS1000 | NS1200 | NS1600 |
| NS630b | | | | | | |
| Ratings 250... 630 A | ■ | ■ | ■ | ■ | ■ | ■ |
| NS800 | | | | | | |
| Ratings 320... 800 A | ■ | ■ | ■ | ■ | ■ | ■ |
| NS1000 | | | | | | |
| Ratings 400... 1000 A | ■ | ■ | ■ | ■ | ■ | ■ |
| NS1200 | | | | | | |
| Ratings 480... 1200 A | ■ | ■ | ■ | ■ | ■ | ■ |
| NS1600 | | | | | | |
| Ratings 640... 1600 A | ■ | ■ | ■ | ■ | ■ | ■ |

⁽¹⁾ When mixing NSX100/250 and NSX400/630 circuit breakers, use the NSX400/630 interlocking system.

Possible combinations

Interlocking of two devices with rotary handles

Possible combinations of "Normal" and "Replacement" source switch-disconnectors

DB 107742.eps

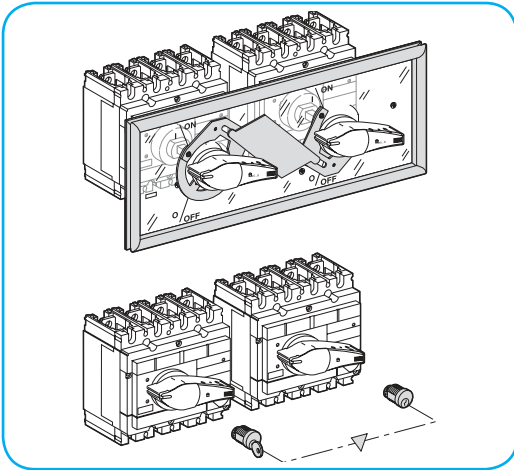

The direct or extended rotary handles are padlocked with the devices in the OFF position. The mechanism prevents simultaneous closing of the devices, but allows them to be opened.

| "Normal N" Compact INS ⁽¹⁾ | "Replacement" R | | | | | |
|--|-----------------|-------|-------|--------|--------|--------|
| | INS40 | INS63 | INS80 | INS100 | INS125 | INS160 |
| INS40 | | | | | | |
| Ratings 40 A | ■ | ■ | ■ | ■ | ■ | ■ |
| INS63 | | | | | | |
| Ratings 63 A | ■ | ■ | ■ | ■ | ■ | ■ |
| INS80 | | | | | | |
| Ratings 80 A | ■ | ■ | ■ | ■ | ■ | ■ |
| INS100 | | | | | | |
| Ratings 100 A | ■ | ■ | ■ | ■ | ■ | ■ |
| INS125 | | | | | | |
| Ratings 125 A | ■ | ■ | ■ | ■ | ■ | ■ |
| INS160 | | | | | | |
| Ratings 160 A | ■ | ■ | ■ | ■ | ■ | ■ |

⁽¹⁾ With extended rotary handles only.

⁽²⁾ Possible with INV, but visible-break function is significantly impaired.

| "Normal N" Compact INS /INV ⁽²⁾ | "Replacement" R | | | | | | | |
|---|-----------------------|-----------------------|-----------------------|-----------------------|-------------------|-------------------|-------------------|-------------------|
| | INS250-100/ INV100 | INS250-160/ INV160 | INS250-200/ INV200 | INS250-250/ INV250 | INS320/ INV320 | INS400/ INV400 | INS500/ INV500 | INS630/ INV630 |
| INS250-100/INV100 | | | | | | | | |
| Ratings 100 A | ■ | ■ | ■ | ■ | □ | □ | □ | |
| INS250-160/INV160 | | | | | | | | |
| Ratings 160 A | ■ | ■ | ■ | ■ | | | | |
| INS250-200/INV200 | | | | | | | | |
| Ratings 200 A | ■ | ■ | ■ | ■ | | | | |
| INS250-250/INV250 | | | | | | | | |
| Ratings 250 A | ■ | ■ | ■ | ■ | □ | | | □ |
| INS320/INV320 | | | | | | | | |
| Ratings 320 A | □ | | | □ | ■ | ■ | ■ | ■ |
| INS400/INV400 | | | | | | | | |
| Ratings 400 A | | | | | ■ | ■ | ■ | ■ |
| INS500/INV500 | | | | | | | | |
| Ratings 500 A | | | | | ■ | ■ | ■ | ■ |
| INS630/INV630 | | | | | | | | |
| Ratings 630 A | □ | | | □ | ■ | ■ | ■ | ■ |

□ 250 A and 630 A ratings can be mixed by using INS320/630 rotary handle interlocking system.

Interlocking of two devices on a base plate

Possible combinations of Compact NSX "Normal" and "Replacement" source circuit breakers

DB4 14891.eps

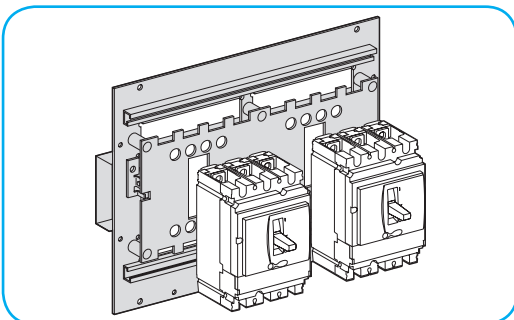

A base plate is available for mechanical interlocking of two manually-operated Compact NSX100 to 630 circuit breakers or switch-disconnectors.

| "Normal N" | "Replacement" R | | | | |
|----------------------|-----------------|--------|--------|--------|--------|
| | NSX100 | NSX160 | NSX250 | NSX400 | NSX630 |
| NSX100 | | | | | |
| Ratings 16... 100 A | ■ | ■ | ■ | ■ | ■ |
| NSX160 | | | | | |
| Ratings 80... 160 A | ■ | ■ | ■ | ■ | ■ |
| NSX250 | | | | | |
| Ratings 125... 250 A | ■ | ■ | ■ | ■ | ■ |
| NSX400 | | | | | |
| Ratings 150... 400 A | ■ | ■ | ■ | ■ | ■ |
| NSX630 | | | | | |
| Ratings 630 A | ■ | ■ | ■ | ■ | ■ |

Interlocking of a number of devices using keylocks (captive keys)

Combination of Masterpact devices

DB101903.eps

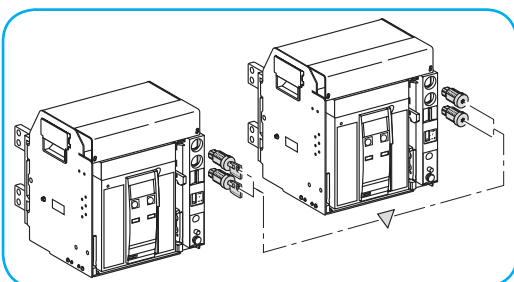

Interlocking uses two identical keylocks with a single key. This solution enables interlocking between two devices that are physically distant or that have significantly different characteristics.

Remote-operated source-changeover systems

Mechanical interlocking Compact NSX, Compact NS or Masterpact NT/NW

Mechanical interlocking of two or three devices is used to create a remote-operated source-changeover system. A basic mechanical interlocking system enhances the reliability of system operation.

PE105106_50.eps



Interlocking of two electrically-operated Compact NSX circuit breakers using a base plate.

Interlocking of two Compact NSX100 to 630 devices using a base plate

A base plate designed for two Compact circuit breakers can be installed horizontally or vertically on a mounting rail. Interlocking is carried out on the base plate by a mechanism located behind the breakers. Access to the circuit breaker controls and trip units is conserved. Circuit breakers must be fixed or plug-in versions, with or without earth-leakage protection or measurement modules. The base plate and the circuit breakers are supplied separately.

■ **Base plate for Compact NSX100 to 250 devices**

This base plate is intended for two Compact NSX100 to 250 devices.

■ **Base plate for Compact NSX400 to 630 devices**

This base plate is intended for two Compact NSX400 to 630 devices. It may also be used, without any modifications, to interlock a fixed Compact NSX100 to 250 with a Compact NSX400 or 630 device.

An adapter kit is required for plug-in versions of the Compact NSX100 to 250 devices.

Compact NSX100 to 250 devices, in both fixed and plug-in versions, may be equipped with spreaders.

Possible combinations of “Normal” and “Replacement” Compact NSX source circuit breakers

| “Normal N” | “Replacement” R | | | | |
|-----------------------|-----------------|--------|--------|--------|--------|
| | NSX100 | NSX160 | NSX250 | NSX400 | NSX630 |
| NSX100 | | | | | |
| Ratings 12,5... 100 A | ■ | ■ | ■ | ■ | ■ |
| NSX160 | | | | | |
| Ratings 12,5...160 A | ■ | ■ | ■ | ■ | ■ |
| NSX250 | | | | | |
| Ratings 12,5...250 A | ■ | ■ | ■ | ■ | ■ |
| NSX400 | | | | | |
| Ratings 160... 400 A | ■ | ■ | ■ | ■ | ■ |
| NSX630 | | | | | |
| Ratings 250... 630 A | ■ | ■ | ■ | ■ | ■ |

DE120268.eps

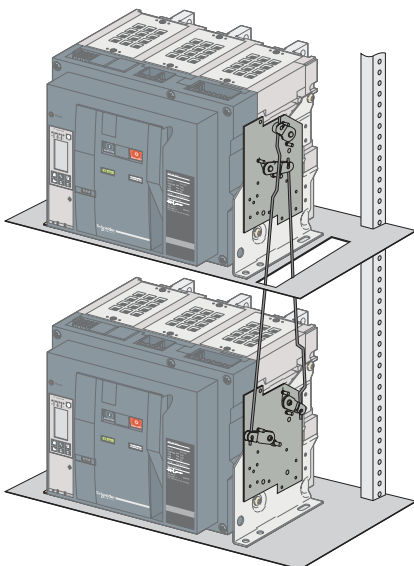

Interlocking of two Masterpact NT or NW circuit breakers using connecting rods.

Interlocking of two Compact NS630b to 1600 or two Masterpact NT and NW devices using connecting rods

The two devices must be mounted one above the other (either 2 fixed or 2 withdrawable/drawout devices).

Combinations are possible between Compact NS630b to NS1600 devices and between Masterpact NT and Masterpact NW devices.

Installation

This function requires:

- an adaptation fixture on the right side of each circuit breaker or switch-disconnector
- a set of connecting rods with no-slip adjustments.

The adaptation fixtures, connecting rods and circuit breakers or switch-disconnectors are supplied separately, ready for assembly by the customer. The maximum vertical distance between the fixing planes is 900 mm.

Possible combinations of “Normal” and “Replacement” source circuit breakers

| “Normal N” | “Replacement” R | | | |
|-------------------------|------------------|--------------|--------------|---------------|
| | NS630b to NS1600 | NT06 to NT16 | NW08 to NW40 | NW40b to NW63 |
| NS630b to NS1600 | | | | |
| Ratings 250... 1600 A | ■ | | | |
| NT06 to NT16 | | | | |
| Ratings 250... 1600 A | | ■ | ■ | ■ |
| NW08 to NW40 | | | | |
| Ratings 320... 4000 A | | ■ | ■ | ■ |
| NW40b to NW63 | | | | |
| Ratings 4000... 6300 A | | ■ | ■ | ■ |

Mechanical interlocking

Compact NS or Masterpact NT/NW

PB100942_00_SE.eps



Interlocking of two Masterpact circuit breakers using cables.

Interlocking of two Compact NS630b to 1600 or two Masterpact NT/NW or up to three Masterpact NW devices using cables

For cable interlocking, the circuit breakers may be mounted one above the other or side-by-side.

The interlocked devices may be fixed or drawout, three-pole or four-pole, and have different ratings and sizes.

Interlocking between two devices (Compact NS630b to 1600 or Masterpact NT and NW)

This function requires:

- an adaptation fixture on the right side of each device
- a set of cables with no-slip adjustments.

The maximum distance between the fixing planes (vertical or horizontal) is 2000 mm.

Interlocking between three devices (Masterpact NW only)

This function requires:

- a specific adaptation fixture for each type of interlocking, installed on the right side of each device
- two or three sets of cables with no-slip adjustments.

The maximum distance between the fixing planes (vertical or horizontal) is 1000 mm.

Installation

The adaptation fixtures, sets of cables and circuit breakers or switch-disconnectors are supplied separately, ready for assembly by the customer.

Installation conditions for cable interlocking systems:

- cable length: 2.5 m
- radius of curvature: 100 mm
- maximum number of curves: 3.

Possible combinations of “Normal” and “Replacement” source circuit breakers

| “Normal N” | “Replacement” R | | | |
|-------------------------|------------------|--------------|--------------|---------------|
| | NS630b to NS1600 | NT06 to NT16 | NW08 to NW40 | NW40b to NW63 |
| NS630b to NS1600 | | | | |
| Ratings 250... 1600 A | ■ | | | |
| NT06 to NT16 | | | | |
| Ratings 250... 1600 A | | ■ | ■ | ■ |
| NW08 to NW40 | | | | |
| Ratings 320... 4000 A | | ■ | ■ | ■ |
| NW40b to NW63 | | | | |
| Ratings 4000... 6300 A | | ■ | ■ | ■ |

It is not possible to combine Compact NS630b to 1600 and Masterpact NT (or Masterpact NW) devices.

All combinations of two Masterpact NT and Masterpact NW devices are possible, whatever the rating or size of the devices.

Possible combinations of three device

| “Normal N” | “Replacement” R | | | |
|-------------------------|------------------|--------------|--------------|---------------|
| | NS630b to NS1600 | NT06 to NT16 | NW08 to NW40 | NW40b to NW63 |
| NS630b to NS1600 | | | | |
| Ratings 250... 1600 A | | | | |
| NT06 to NT16 | | | | |
| Ratings 250... 1600 A | | | | |
| NW08 to NW40 | | | | |
| Ratings 320... 4000 A | | | ■ | ■ |
| NW40b to NW63 | | | | |
| Ratings 4000... 6300 A | | | ■ | ■ |

Only Masterpact NW may be used for three-device combinations.

Types of mechanical interlocking and combinations

See page A-4 to page A-9.

Remote-operated source-changeover systems

General characteristics

Compact NSX

| Range | | Compact NSX | |
|---|--|---|---|
| Types of devices | | NSX100 to NSX250 | NSX400 to NSX630 |
| Types of circuit breakers | | N / H / L | N / H / L |
| Switch-disconnector version | | NA | NA |
| Mixing possibilities | | all devices NS100 to NS250 N/H/L/NA fixed or plug-in | all devices NS100 to NS630 N/H/L/NA fixed or plug-in |
| Electrical characteristics | | | |
| Rating | | 15 to 250 A | 15 to 630 A |
| Insulating voltage U_i (V AC) | | 750 | 750 |
| Positive break indication | | ■ | ■ |
| Number of poles (N and R devices must have the same number of poles) | | 3, 4 | |
| Electrical durability | | See page A-14 | |
| Operating temperature | | -25 °C to +70 °C (50 °C for 440 V - 60 Hz) | |
| Control characteristics | | | |
| Control voltage | AC | 48 V - 50 Hz 110/130, 220/240, 380/440 V - 50/60 Hz | 48 V - 50 Hz 110/130, 220/240, 380/440 V - 50/60 Hz |
| | DC | 24-250 V | 24-250 V |
| Maximum consumption | AC | 500 VA | 500 VA |
| | DC | 500 W | 500 W |
| Minimum switching time | | 800 ms | 800 ms |
| Interlocking | | | |
| Mechanical (see page A-10) | | | |
| Electrical | by diagram (without IVE) | ■ | ■ |
| | with IVE unit | ■ | ■ |
| | auxiliary contacts used by circuit breaker | 1 OF + 1 SDE | 1 OF + 1 SDE |
| Protection and measurement | | | |
| Overload protection | long time | ■ | ■ |
| Short-circuit protection | short time | ■ | ■ |
| | instantaneous | ■ | ■ |
| Earth-fault protection | | | ■ |
| Zone selective interlocking (ZSI) | | | ■ |
| Earth-leakage protection | by Vigi module | ■ | ■ |
| | by control unit | | |
| | by add-on Vigirex relay | ■ | ■ |
| Current measurements | | | |
| Voltage, frequency, power measurements, etc. | | | |
| Indication and control auxiliaries | | | |
| Available auxiliary indication contacts | | OF + SD (+ SDV) | 3 OF + SD (+ SDV) |
| Voltage releases | MX shunt | ■ | ■ |
| | MN undervoltage | ■ | ■ |
| Voltage presence indicator | | ■ | ■ |
| Voltage transformer | | ■ | ■ |
| Ammeter module | | ■ | ■ |
| Insulation monitoring module | | ■ | ■ |
| Source-changeover controller | | | |
| With permanent replacement source | | ■ BA controller | |
| With standby generator set | | ■ UA controller | |
| Remote communication via bus | | | |
| Device status indications | | | |
| Device remote control | | | |
| Transmission of settings | | ■ | ■ |
| Indication and identification of protection status and alarms | | ■ | ■ |
| Transmission of measurements | | ■ | ■ |
| Installation and connection | | | |
| Fixed front connected | | | |
| Fixed rear connected | | ■ (long rear connections) | ■ (long rear connections) |
| Withdrawable, plug-in or drawout | | ■ (plug-in on base) | ■ (plug-in on base) |
| Installation and connection accessories | | | |
| Downstream coupling accessory | | ■ | ■ |
| Bare-cable connectors | | ■ | ■ |
| Terminal extensions | | ■ | ■ |
| Terminal shields and inter-phase barriers | | ■ | ■ |
| Locking | by padlock | ■ | ■ |
| | by keylock | ■ | ■ |
| Front panel escutcheons | | ■ | ■ |

Remote-operated source-changeover systems

Mech. and elect. durability Compact INS,
Compact NSX, NS, Masterpact NT/NW

Compact INS switch-disconnectors

| | | INS250-100 | | INS250-160 | | INS250-200 | | INS250 | |
|--|--------------------------------|--------------|--------------|--------------|--------------|--------------|--------------|--------------|--------------|
| Number of poles | | 3, 4 | | 3, 4 | | 3, 4 | | 3, 4 | |
| Conventional thermal current (A) I_{th} at 60 °C | | 100 | | 160 | | 200 | | 250 | |
| Rated operational current (A) I_e | Electrical AC, 50/60 Hz | AC22A | AC23A | AC22A | AC23A | AC22A | AC23A | AC22A | AC23A |
| | 440-480 V | 100 | 100 | 160 | 160 | 200 | 200 | 250 | 250 |
| | 660-690 V | 100 | 100 | 160 | 160 | 200 | 200 | 250 | 250 |
| Durability (category A) (O _N -C _R -O _R -C _N cycles) | Mechanical | 15000 | | 15000 | | 15000 | | 15000 | |
| | Electrical AC, 50/60 Hz | AC22A | AC23A | AC22A | AC23A | AC22A | AC23A | AC22A | AC23A |
| | 440-480 V | 1500 | 1500 | 1500 | 1500 | 1500 | 1500 | 1500 | 1500 |
| | 660-690 V | 1500 | 1500 | 1500 | 1500 | 1500 | 1500 | 1500 | 1500 |

| | | INS320 | | INS400 | | INS500 | | INS630 | |
|--|--------------------------------|--------------|--------------|--------------|--------------|--------------|--------------|--------------|--------------|
| Number of poles | | 3, 4 | | 3, 4 | | 3, 4 | | 3, 4 | |
| Conventional thermal current (A) I_{th} at 60 °C | | 320 | | 400 | | 500 | | 630 | |
| Rated operational current (A) I_e | Electrical AC, 50/60 Hz | AC22A | AC23A | AC22A | AC23A | AC22A | AC23A | AC22A | AC23A |
| | 440-480 V | 320 | 320 | 400 | 400 | 500 | 500 | 630 | 630 |
| | 660-690 V | 320 | 320 | 400 | 400 | 500 | 500 | 630 | 630 |
| Durability (category A) (O _N -C _R -O _R -C _N cycles) | Mechanical | 10000 | | 10000 | | 10000 | | 10000 | |
| | Electrical AC, 50/60 Hz | AC22A | AC23A | AC22A | AC23A | AC22A | AC23A | AC22A | AC23A |
| | 440-480 V | 1500 | 1500 | 1500 | 1500 | 1500 | 1500 | 1500 | 1500 |
| | 660-690 V | 1500 | 1500 | 1500 | 1500 | 1500 | 1500 | 1500 | 1500 |

Compact NSX100-630, Compact NS630b-1600

| | NSX100-250 | NSX400-630 | NS630b-NS1600 |
|--|-----------------------|-------------|---------------|
| Number of poles | 3, 4 | 3, 4 | 3, 4 |
| Rated current I _n (A) | 100 to 250 | 400 to 630 | 630 to 1600 |
| Mechanical durability (O _N -C _R -O _R -C _N cycles) | 20000 - 40000 - 50000 | 15000 | 8000 |
| Electrical durability at I _n (O _N -C _R -O _R -C _N cycles) for ≤ 440 V and 480 V NEMA ⁽²⁾ | 10000 - 20000 - 30000 | 4000 - 6000 | 2000 |
| Electrical durability at I _n (O _N -C _R -O _R -C _N cycles) for U = 500 V to 690 V ⁽²⁾ | 5000 - 7500 - 10000 | 2000 - 3000 | 1500 |

Masterpact NT06-NT16/NW08-NW63 ⁽¹⁾

| | NT06-NT10 | NT12-NT16 | NW08-NW16 | NW20 | NW25-NW40 | NW50-NW63 |
|--|-------------|-----------------------|-------------|-------|--------------|--------------|
| Number of poles | 3, 4 | 3, 4 | 3, 4 | 3, 4 | 3, 4 | 3, 4 |
| Rated current I _n (A) | 630 to 1600 | 1250 to 1600 | 800 to 1600 | 2000 | 2500 to 4000 | 5000 to 6300 |
| Mechanical durability (O _N -C _R -O _R -C _N cycles) | 8000 | 8000 | 10000 | 10000 | 10000 | 5000 |
| Electrical durability at I _n (O _N -C _R -O _R -C _N cycles) for ≤ 440 V and 480 V NEMA ⁽²⁾ | 6000 | 6000 NT16: 3000 | 10000 | 8000 | 5000 | 1500 |
| Electrical durability at I _n (O _N -C _R -O _R -C _N cycles) for U = 500 V to 690 V ⁽²⁾ | 3000 | 2000 NT16: 1000 | 10000 | 6000 | 2500 | 1500 |

⁽¹⁾ Mechanical and electrical durability not applicable to Masterpact H3 and L versions.

⁽²⁾ Electrical durability tests carried out with a power factor of 0.8 as per IEC 947-2.

Note:

O_N: opening of Normal source

C_R: closing of Replacement source

O_R: opening of Replacement source

C_N: closing of Normal source

Connection and insulation accessories for Compact NSX and INS ≤ 630 A

DEM13568.eps

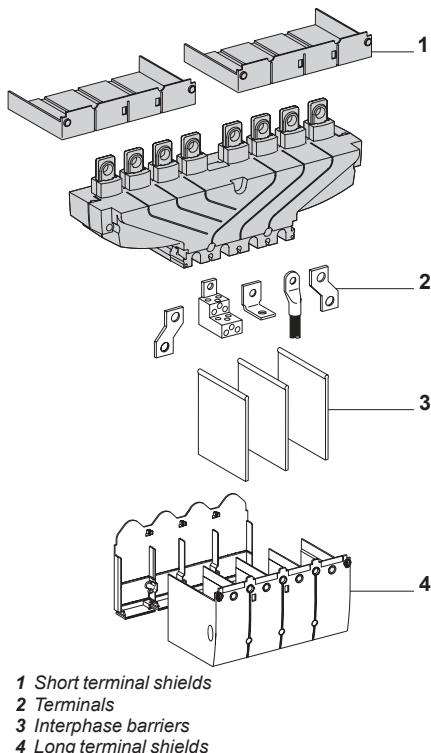

- 1 Short terminal shields
- 2 Terminals
- 3 Interphase barriers
- 4 Long terminal shields

Downstream coupling accessory

This accessory simplifies connection to bars and cables with lugs. It may be used to couple two circuit breakers (Compact NSX100 to 630) or switch-disconnectors (Compact INS/INV100 to 630) of the same size.

Pitch between outgoing terminals:

- Compact INS250 and INV100 to 250: 35 mm
- Compact INS/INV320 to 630: 45 mm
- Compact NSX100 to 250: 35 mm
- Compact NSX400 to 630: 45 mm.

For Compact NSX circuit breakers, the downstream coupling accessory can be used only with **fixed versions**.

Connection and insulation accessories

The coupling accessory can be fitted with the same connection and insulation accessories as the circuit breakers and switch-disconnectors.

| Possible uses | Downstream coupling | |
|--|---------------------|---------------------|
| | Possible mounting | Outgoing pitch (mm) |
| Manual source-changeover systems | | |
| INS250 (100 to 250 A) with rotary handle | ■ | 35 |
| NSX100/250 with rotary handle | ■ | 35 |
| NSX100/250 on base plate with toggle control | ■ | 35 |
| INS400/630 (320 to 630 A) with rotary handle | ■ | 45 |
| NSX400/630 with rotary handle | ■ | 45 |
| NSX400/630 on base plate with toggle control | ■ | 45 |
| Complete source-changeover assembly | | |
| INS250 (100 to 250 A) | ■ | 35 |
| INS400/630 (320 to 630 A) | ■ | 45 |
| Remote-operated source-changeover systems | | |
| NSX100/250 | ■ | 35 |
| NSX400/630 | ■ | 45 |

Remote-operated source-changeover systems

Electrical interlocking

Electrical interlocking is used with a mechanical interlocking system.
An automatic controller may be added to take into account information from the distribution system.

Moreover, the relays controlling the closing order to the “Normal” and “Replacement” circuit-breakers must be mechanically and/or electrically interlocked to prevent them from giving simultaneous closing commands.

Electrical interlocking is carried out by an electrical control device.
For Compact NSX up to 630 A, electrical interlocking is implemented by the IVE unit integrating control circuits and an external terminal block in accordance with the pages C-5 to C-4 of the chapter “Electric diagrams” of this catalogue.

The integrated control circuits implement the time delays required for correct source transfer.

For Compact NS630b to 1600 and Masterpact, this function can be implemented in one of two ways:

- using the IVE unit
- by an electrician based on the diagrams in accordance with the pages C-9 to C-14 of the chapter “Electric diagrams” of this catalogue.

Characteristics of the IVE unit

- External connection terminal block:
 - inputs: circuit breaker control signals
 - outputs: status of the SDE contacts on the “Normal” and “Replacement” source circuit breakers.
- 2 connectors for the two “Normal” and “Replacement” source circuit breakers:
 - inputs:
 - status of the OF contacts on each circuit breaker (ON or OFF)
 - status of the SDE contacts on the “Normal” and “Replacement” source circuit breakers
 - outputs: power supply for operating mechanisms.
- Control voltage:
 - 24 to 250 V DC
 - 48 to 415 V 50/60 Hz - 440 V 60 Hz.

The IVE unit control voltage must be same as that of the circuit breaker operating mechanisms.

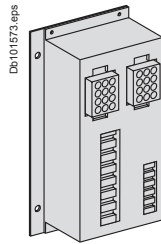

IVE unit.

Necessary equipment

For Compact NSX100 to 630, each circuit breaker must be equipped with:

- a motor mechanism
- an OF contact
- an SDE contact.

The components are supplied ready for assembly and the circuit breakers prewired. The rewiring must not be modified.

For Compact NS630b to 1600, each circuit breaker must be equipped with:

- a motor mechanism
- an available OF contact
- a CE connected-position contact (carriage switch) on withdrawable circuit breakers
- an SDE contact.

For Masterpact NT and NW, each circuit breaker must be equipped with:

- a remote-operation system made up of:
 - MCH gear motor
 - MX or MN opening release
 - XF closing release
 - PF “ready to close” contact
- an available OF contact
- one to three CE connected-position contacts (carriage switches) on drawout circuit breakers (depending on the installation).

Standard configurations

Compact NS, Masterpact NT and NW

| Types of mechanical interlocking | Possible combinations | Typical electrical diagrams | Diagram no. | | | | | | | |
|----------------------------------|---|-----------------------------|-------------|---|---|---|---|---|---|---|
| 2 devices | | | | | | | | | | |
| <p>Db101574.eps</p> | <table border="1"> <thead> <tr> <th>QN</th> <th>QR</th> </tr> </thead> <tbody> <tr> <td>0</td> <td>0</td> </tr> <tr> <td>1</td> <td>0</td> </tr> <tr> <td>0</td> <td>1</td> </tr> </tbody> </table> | QN | QR | 0 | 0 | 1 | 0 | 0 | 1 | <p>Compact NSX100 to 630:</p> <ul style="list-style-type: none"> ■ electrical interlocking without emergency power off (EPO) auxiliaries: 51201177 □ with EPO by MN 51201178 □ with EPO by MX 51201179 <p>Compact NS630b to 1600:</p> <ul style="list-style-type: none"> ■ electrical interlocking with lockout after fault: <ul style="list-style-type: none"> □ permanent replacement source (with IVE) 51201183 □ with EPO by MX (with IVE) 51201184 □ with EPO by MN (with IVE) 51201185 <p>Masterpact NT and NW:</p> <ul style="list-style-type: none"> ■ electrical interlocking with lockout after fault: <ul style="list-style-type: none"> □ permanent replacement source (with IVE) 51201142 □ with EPO by MX (with IVE) 51201143 □ with EPO by MN (with IVE) 51201144 ■ automatic control with lockout after fault: <ul style="list-style-type: none"> □ permanent replacement source (with IVE) 51156904 □ engine generator set (with IVE) 51156905 ■ BA/UA controller (with IVE) 51156903 |
| QN | QR | | | | | | | | | |
| 0 | 0 | | | | | | | | | |
| 1 | 0 | | | | | | | | | |
| 0 | 1 | | | | | | | | | |

Masterpact NW only

| Types of mechanical interlocking | Possible combinations | Typical electrical diagrams | Diagram no. | | | | | | | | | | | | | | | | | | | | |
|---|---|-----------------------------|-------------|-----|---|---|---|---|---|---|---|---|---|---|---|---|---|---|---|---|---|---|---|
| 3 devices: 2 "Normal" sources and 1 "Replacement" source | | | | | | | | | | | | | | | | | | | | | | | |
| <p>Db101575.eps</p> | <table border="1"> <thead> <tr> <th>QN1</th> <th>QN2</th> <th>QR</th> </tr> </thead> <tbody> <tr> <td>0</td> <td>0</td> <td>0</td> </tr> <tr> <td>1</td> <td>1</td> <td>0</td> </tr> <tr> <td>0</td> <td>0</td> <td>1</td> </tr> </tbody> </table> | QN1 | QN2 | QR | 0 | 0 | 0 | 1 | 1 | 0 | 0 | 0 | 1 | <ul style="list-style-type: none"> ■ electrical interlocking: <ul style="list-style-type: none"> □ without lockout after fault 51156906 □ with lockout after fault 51156907 | | | | | | | | | |
| QN1 | QN2 | QR | | | | | | | | | | | | | | | | | | | | | |
| 0 | 0 | 0 | | | | | | | | | | | | | | | | | | | | | |
| 1 | 1 | 0 | | | | | | | | | | | | | | | | | | | | | |
| 0 | 0 | 1 | | | | | | | | | | | | | | | | | | | | | |
| 3 devices: 2 "Normal" sources and 1 "Replacement" source with source selection | | | | | | | | | | | | | | | | | | | | | | | |
| <p>Db101576.eps</p> | <table border="1"> <thead> <tr> <th>QN1</th> <th>QN2</th> <th>QR</th> </tr> </thead> <tbody> <tr> <td>0</td> <td>0</td> <td>0</td> </tr> <tr> <td>1</td> <td>0</td> <td>0</td> </tr> <tr> <td>0</td> <td>0</td> <td>1</td> </tr> <tr> <td>1</td> <td>1</td> <td>0</td> </tr> <tr> <td>0</td> <td>1</td> <td>0</td> </tr> </tbody> </table> | QN1 | QN2 | QR | 0 | 0 | 0 | 1 | 0 | 0 | 0 | 0 | 1 | 1 | 1 | 0 | 0 | 1 | 0 | <ul style="list-style-type: none"> ■ automatic control with engine generator set: <ul style="list-style-type: none"> □ without lockout after fault (with MN) 51156908 □ with lockout after fault (with MN) 51156909 | | | |
| QN1 | QN2 | QR | | | | | | | | | | | | | | | | | | | | | |
| 0 | 0 | 0 | | | | | | | | | | | | | | | | | | | | | |
| 1 | 0 | 0 | | | | | | | | | | | | | | | | | | | | | |
| 0 | 0 | 1 | | | | | | | | | | | | | | | | | | | | | |
| 1 | 1 | 0 | | | | | | | | | | | | | | | | | | | | | |
| 0 | 1 | 0 | | | | | | | | | | | | | | | | | | | | | |
| 3 devices: 3 sources, only one device | | | | | | | | | | | | | | | | | | | | | | | |
| <p>Db101577.eps</p> | <table border="1"> <thead> <tr> <th>QS1</th> <th>QS2</th> <th>QS3</th> </tr> </thead> <tbody> <tr> <td>0</td> <td>0</td> <td>0</td> </tr> <tr> <td>1</td> <td>0</td> <td>0</td> </tr> <tr> <td>0</td> <td>1</td> <td>0</td> </tr> <tr> <td>0</td> <td>0</td> <td>1</td> </tr> </tbody> </table> | QS1 | QS2 | QS3 | 0 | 0 | 0 | 1 | 0 | 0 | 0 | 1 | 0 | 0 | 0 | 1 | <ul style="list-style-type: none"> ■ electrical interlocking: <ul style="list-style-type: none"> □ without lockout after fault 51156910 □ with lockout after fault 51156911 | | | | | | |
| QS1 | QS2 | QS3 | | | | | | | | | | | | | | | | | | | | | |
| 0 | 0 | 0 | | | | | | | | | | | | | | | | | | | | | |
| 1 | 0 | 0 | | | | | | | | | | | | | | | | | | | | | |
| 0 | 1 | 0 | | | | | | | | | | | | | | | | | | | | | |
| 0 | 0 | 1 | | | | | | | | | | | | | | | | | | | | | |
| 3 devices: 2 sources + 1 coupling | | | | | | | | | | | | | | | | | | | | | | | |
| <p>Db101578.eps</p> | <table border="1"> <thead> <tr> <th>QS1</th> <th>QC</th> <th>QS2</th> </tr> </thead> <tbody> <tr> <td>0</td> <td>0</td> <td>0</td> </tr> <tr> <td>1</td> <td>0</td> <td>1</td> </tr> <tr> <td>1</td> <td>1</td> <td>0</td> </tr> <tr> <td>0</td> <td>1</td> <td>1</td> </tr> <tr> <td>1</td> <td>0</td> <td>0</td> </tr> <tr> <td>0</td> <td>0</td> <td>1</td> </tr> </tbody> </table> <p>(1) possible by forcing operation</p> | QS1 | QC | QS2 | 0 | 0 | 0 | 1 | 0 | 1 | 1 | 1 | 0 | 0 | 1 | 1 | 1 | 0 | 0 | 0 | 0 | 1 | <ul style="list-style-type: none"> ■ electrical interlocking: <ul style="list-style-type: none"> □ without lockout after fault 51156912 □ with lockout after fault 51156913 ■ automatic control with lockout after fault 51156914 |
| QS1 | QC | QS2 | | | | | | | | | | | | | | | | | | | | | |
| 0 | 0 | 0 | | | | | | | | | | | | | | | | | | | | | |
| 1 | 0 | 1 | | | | | | | | | | | | | | | | | | | | | |
| 1 | 1 | 0 | | | | | | | | | | | | | | | | | | | | | |
| 0 | 1 | 1 | | | | | | | | | | | | | | | | | | | | | |
| 1 | 0 | 0 | | | | | | | | | | | | | | | | | | | | | |
| 0 | 0 | 1 | | | | | | | | | | | | | | | | | | | | | |

"Lockout after fault" option. This option makes it necessary to manually reset the device following fault tripping.

By combining a remote-operated source-changeover system with an integrated BA or UA automatic controller, it is possible to automatically control source transfer according to user-selected sequences. These controllers can be used on source-changeover systems comprising 2 circuit breakers. For source-changeover systems comprising 3 circuit breakers, the automatic control diagram must be prepared by the installer as a complement to diagrams provided in the "electrical diagrams" section of this catalogue.

DB403909.eps



BA controller.

DB403910.eps



UA controller.

| Controller | BA | UA | | | | | |
|--|---|-----------|-----------|------|------|------|------|
| Compatible circuit breakers | All Compact NS, Compact NSX and Masterpact circuit breakers | | | | | | |
| 4-position switch | | | | | | | |
| Automatic operation | ■ | ■ | | | | | |
| Forced operation on "Normal" source | ■ | ■ | | | | | |
| Forced operation on "Replacement" source | ■ | ■ | | | | | |
| Stop (both "Normal" and "Replacement" sources off) | ■ | ■ | | | | | |
| Automatic operation | | | | | | | |
| Monitoring of the "Normal" source and automatic transfer | ■ | ■ | | | | | |
| Generator set startup control | | ■ | | | | | |
| Delayed shutdown (adjustable) of generator set | | ■ | | | | | |
| Load shedding and reconnection of non-priority circuits | | ■ | | | | | |
| Transfer to the "Replacement" source if one of the phases of the "Normal" phase is absent | | ■ | | | | | |
| Test | | | | | | | |
| By opening the P25M circuit breaker supplying the controller | ■ | | | | | | |
| By pressing the test button on the front of the controller | | ■ | | | | | |
| Indications | | | | | | | |
| Circuit breaker status indication on the front of the controller: on, off, fault trip | ■ | ■ | | | | | |
| Automatic mode indicating contact | ■ | ■ | | | | | |
| Other functions | | | | | | | |
| Selection of type of "Normal" source (single-phase or three-phase) ⁽¹⁾ | | ■ | | | | | |
| Voluntary transfer to "Replacement" source (e.g. energy management commands) | ■ | ■ | | | | | |
| During peak-tariff periods (energy management commands) forced operation on "Normal" source if "Replacement" source not operational | | ■ | | | | | |
| Additional contact (not part of controller). Transfer to "Replacement" source only if contact is closed (e.g. used to test the frequency of UR). | ■ | ■ | | | | | |
| Setting of maximum startup time for the replacement source | | ■ | | | | | |
| Options | | | | | | | |
| Communication option | | | | | | | |
| Power supply | | | | | | | |
| Control voltages ⁽²⁾ | 110 V | ■ | ■ | | | | |
| | 220 to 240 V 50/60 Hz | ■ | ■ | | | | |
| | 380 to 415 V 50/60 Hz and 440 V 60 Hz | ■ | ■ | | | | |
| Operating thresholds | | | | | | | |
| Undervoltage | 0.35 Un ≤ voltage ≤ 0.7 Un | ■ | ■ | | | | |
| Phase failure | 0.5 Un ≤ voltage ≤ 0.7 Un | | ■ | | | | |
| Voltage presence | voltage ≥ 0.85 Un | ■ | ■ | | | | |
| IP degree of protection (EN 60529) and IK degree of protection against external mechanical impacts (EN 50102) | | | | | | | |
| Front | IP40 | ■ | ■ | | | | |
| Side | IP30 | ■ | ■ | | | | |
| Connectors | IP20 | ■ | ■ | | | | |
| Front | IK07 | ■ | ■ | | | | |
| Characteristics of output contacts (dry, volt-free contacts) | | | | | | | |
| Rated thermal current (A) | 8 | | | | | | |
| Minimum load | 10 mA at 12 V | | | | | | |
| Output contacts: | | | | | | | |
| Position of the Auto/Stop switch | | ■ | ■ | | | | |
| Load shedding and reconnection order | | | ■ | | | | |
| Generator set start order. | | | ■ | | | | |
| | | AC | DC | | | | |
| Utilisation category (IEC 947-5-1) | | AC12 | AC13 | AC14 | AC15 | DC12 | DC13 |
| Operational current (A) | 24 V | 8 | 7 | 5 | 5 | 8 | 2 |
| | 48 V | 8 | 7 | 5 | 5 | 2 | - |
| | 110 V | 8 | 6 | 4 | 4 | 0.6 | - |
| | 220/240 V | 8 | 6 | 4 | 3 | - | - |
| | 250 V | - | - | - | - | 0.4 | - |
| | 380/415 V | 5 | - | - | - | - | - |
| | 440 V | 4 | - | - | - | - | - |
| | 660/690 V | - | - | - | - | - | - |

(1) For example, 220 V single-phase or 220 V three-phase.

(2) The controller is powered by the ACP control plate. The same voltage must be used for the ACP plate, the IVE unit and the circuit breaker operating mechanisms. If this voltage is the same as the source voltage, then the "Normal" and "Replacement" sources can be used directly for the power supply. If not, an isolation transformer must be used.

Controller installation

PE100857_SE.eps



ACP control plate.

ACP control plate

The control plate provides in a single unit:

- protection for the BA or UA controller with two highly limiting P25M circuit breakers (infinite breaking capacity) for power drawn from the AC source
- control of circuit-breaker ON and OFF functions via two relay contactors
- connection of the circuit breakers to the BA or UA controller via a built-in terminal block.

Control voltages

- 110 V 50/60 Hz.
- 220 to 240 V 50/60 Hz.
- 380 to 415 V 50/60 Hz and 440 V 60 Hz.

The same voltage must be used for the ACP control plate, the controller and the circuit breaker operating mechanisms.

Installation

Connection between the ACP control plate and the IVE unit may use:

- wiring done by the installer
- prefabricated wiring (optional).

Installation of the BA and UA controllers

The BA and UA controllers may be installed in one of two manners:

- directly mounted on the ACP control plate
- mounted on the front panel of the switchboard
- if the length of the connection between the controller and the control plate (ACP) is less than or equal to 1 m, the connecting cable **ref. 29368** can be ordered as an optional extra. Cables longer than 1 m, but not longer than 2 m will be the responsibility of the installer.

DB 120289 eps

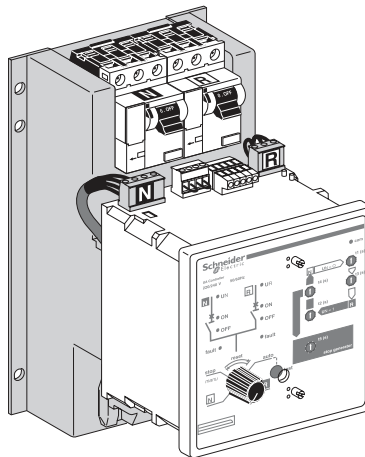

Mounting on the ACP control plate.

DB128270 eps

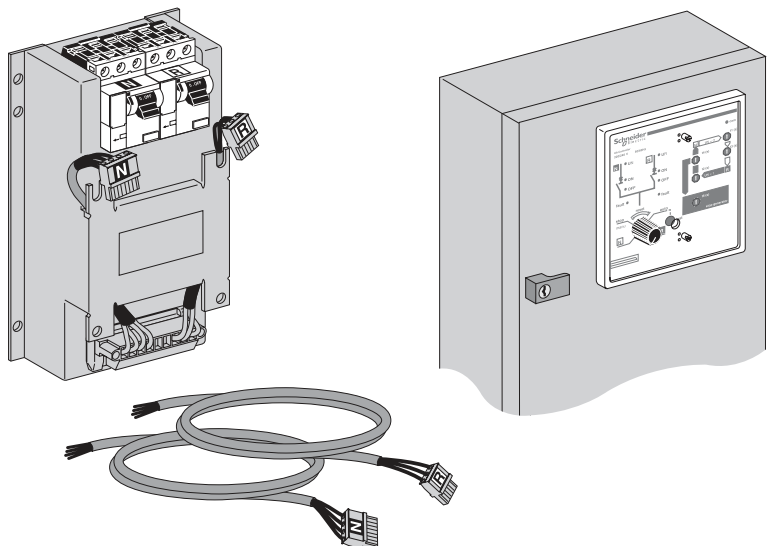

Mounting on the front panel of the switchboard.

The BA controller is used to create simple source-changeover systems that switch from one source to another depending on the presence of voltage U_N on the “Normal” source.

It is generally used to manage two permanent sources and can control Compact NS, Compact NSX and Masterpact NT/NW circuit breakers and switch-disconnectors.

DB403841.eps



DB403838.eps

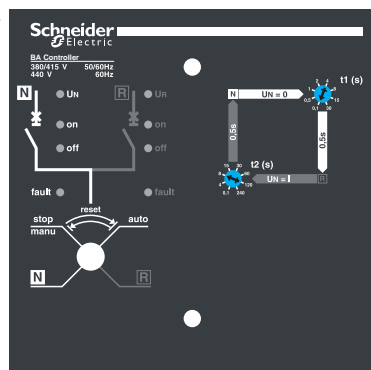

Front of the BA controller.

Operating modes

A four-position switch may be used to select:

- automatic operation
- forced operation on the “Normal” source
- forced operation on the “Replacement” source
- stop (both “Normal” and “Replacement” sources off).

Setting the time delays

Time delays are set on the front of the controller.

t1. delay between detection that the “Normal” source has failed and the transmission of the order to open the “Normal” source circuit breaker (adjustable from 0.1 to 30 seconds).

t2. delay between detection that the “Normal” source has returned and the transmission of the order to open the “Replacement” source circuit breaker (adjustable from 0.1 to 240 seconds).

Circuit breaker commands and status indications

The status of the circuit breakers is indicated on the front of the controller.

- ON, OFF, fault.

A built-in terminal block may be used to connect the following input/output signals:

- inputs:
 - voluntary order to transfer to source R (e.g. for special tariffs, etc.)
 - additional control contact (not part of the controller). Transfer to the “Replacement” source takes place only if the contact is closed (e.g. used to test the frequency of UR, etc.)
- outputs:
 - indication of operation in automatic or stop mode via changeover contacts.

Test

It is possible to test the operation of the BA controller by turning OFF (opening) the P25M circuit breaker for the “Normal” source and thus simulating a failure of voltage U_N .

BA controller Operating sequences

Switch set to Auto (automatic operation and special-tariff mode)

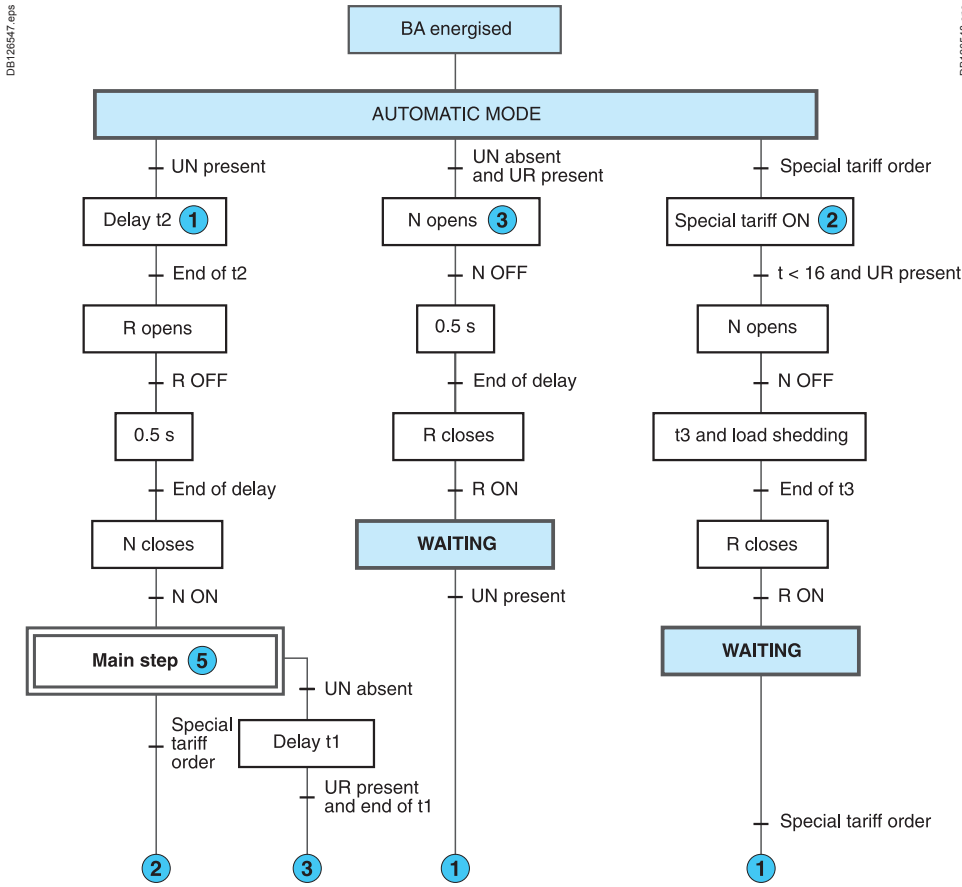

Switch set to the "N" position (forced operation on the "Normal" source)

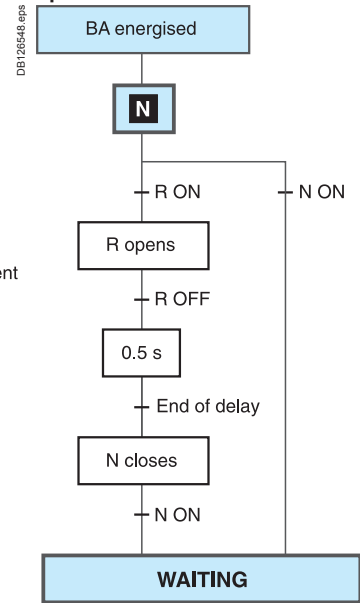

Switch set to the "R" position (forced operation on the "Replacement" source)

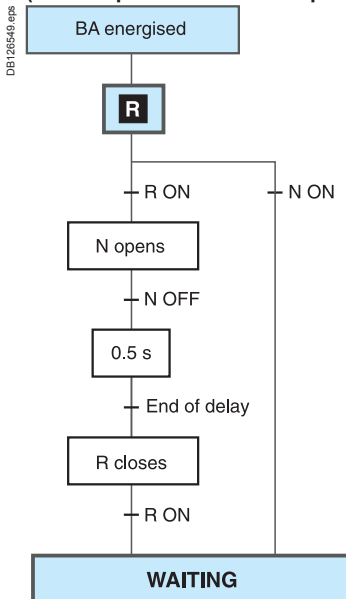

Switch set to the "Stop" position

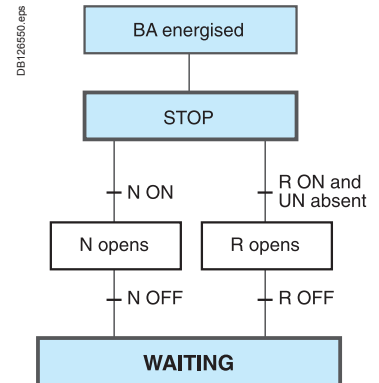

Key

UN : "Normal" source voltage
UR : "Replacement" source voltage
N : "Normal" source circuit breaker
R : "Replacement" source circuit breaker

WAITING The system exits this mode when the operating mode is modified or when an external event occurs (e.g. failure or return of UN).

① The number sends to the indicated step when the condition is true.

The UA controller is used to create a source-changeover system integrating the following automatic functions:

- transfer from one source to another depending on the presence of voltage UN on the “Normal” source
- startup of an engine generator set
- shedding and reconnection of non-priority circuits
- transfer to the “Replacement” source if one of the phases on the “Normal” source fails.

The UA controller can control Compact NS, Compact NSX and Masterpact NT/NW devices.

Operating modes

A four-position switch may be used to select:

- automatic operation
- forced operation on the “Normal” source
- forced operation on the “Replacement” source
- stop (both “Normal” and “Replacement” sources off, then manual operation).

Setting the time delays

Time delays are set on the front of the controller.

- t1.** delay between detection that the “Normal” source has failed and the transmission of the order to open the “Normal” source circuit breaker (adjustable from 0.1 to 30 seconds).
- t2.** delay between detection that the “Normal” source has returned and the transmission of the order to open the “Replacement” source circuit breaker (adjustable from 0.1 to 240 seconds).
- t3.** delay following opening of QN with load shedding and before closing of QR (adjustable from 0.5 to 30 seconds).
- t4.** delay following opening of QR with load reconnection and before closing of QN (adjustable from 0.5 to 30 seconds).
- t5.** delay for confirmation that UN is present before shutting down the engine generator set (adjustable from 60 to 600 seconds).
- t6.** delay before startup of the engine generator set (120 or 180 seconds).

Commands and indications

Circuit breaker status indications on the front of the controller:

- ON, OFF, fault.

A built-in terminal block may be used to connect the following input/output signals:

- inputs:
 - voluntary order to transfer to source R (e.g. for special tariffs, etc.)
 - additional control contact (not part of the controller). Transfer to the “Replacement” source takes place only if the contact is closed (e.g. used to test the frequency of UR, etc.)
- outputs:
 - control of an engine generator set (ON / OFF)
 - shedding of non-priority circuits
 - indication of operation in automatic mode via changeover contacts.

Distribution-system settings

Three switches are used to:

- select the type of “Normal” source, whether single-phase or three-phase (e.g. 240 V single-phase or 240 V three-phase)
- select whether to remain (or not) on the “Normal” source if the “Replacement” source is not operational during operation on special tariffs
- select the maximum permissible startup time for the engine generator set during operation on special tariffs (120 or 180 seconds).

Test

A pushbutton on the front of the controller may be used to test transfer from the “Normal” source to the “Replacement” source, then the return to the “Normal” source. The test lasts approximately three minutes.

COM communications option

Using the internal bus protocol, this option may be used to remote the following information:

- circuit breaker status (ON, OFF, fault trip)
- presence of the “Normal” and “Replacement” voltages
- presence of an order for forced operation (e.g. special tariffs)
- settings and configuration information
- status of non-priority circuits (loads shed or not)
- position of the switch (stop, auto, forced operation on the “Normal” source, forced operation on the “Replacement” source).

DB403942.eps



DB403937.eps

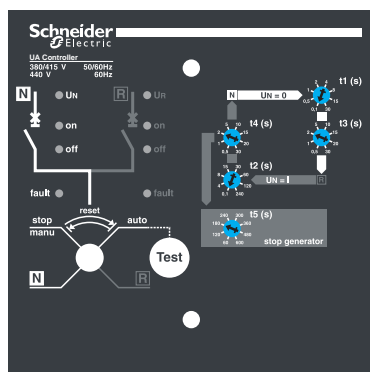

Front of the UA controller.

UA controller Operating sequences Forced operation mode

Switch set to the "R" position (forced operation on the "Replacement" source)

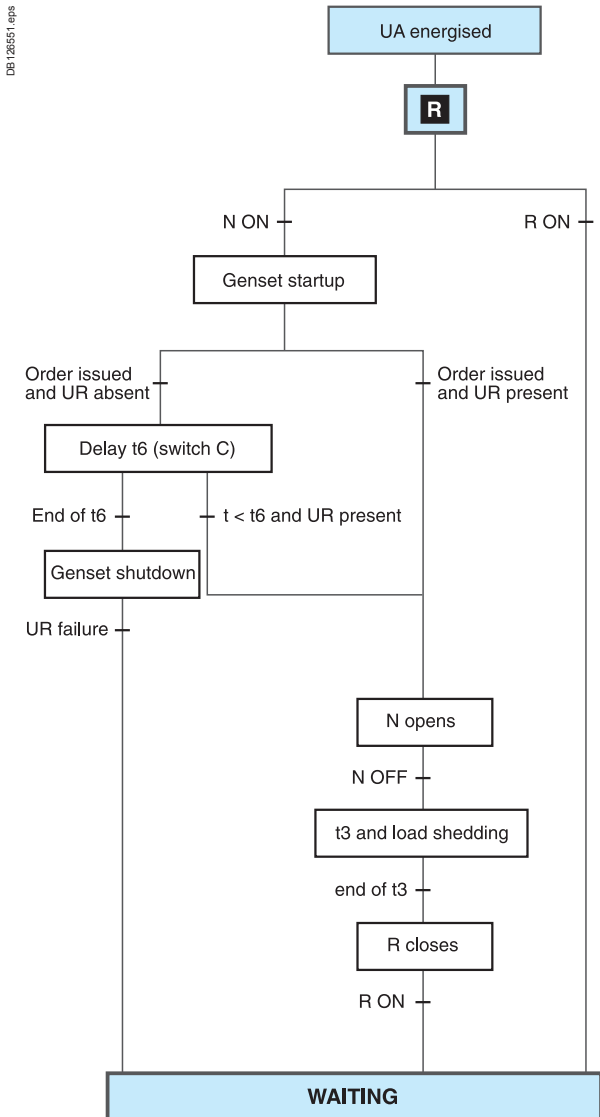

Switch set to the "N" position (forced operation on the "Normal" source)

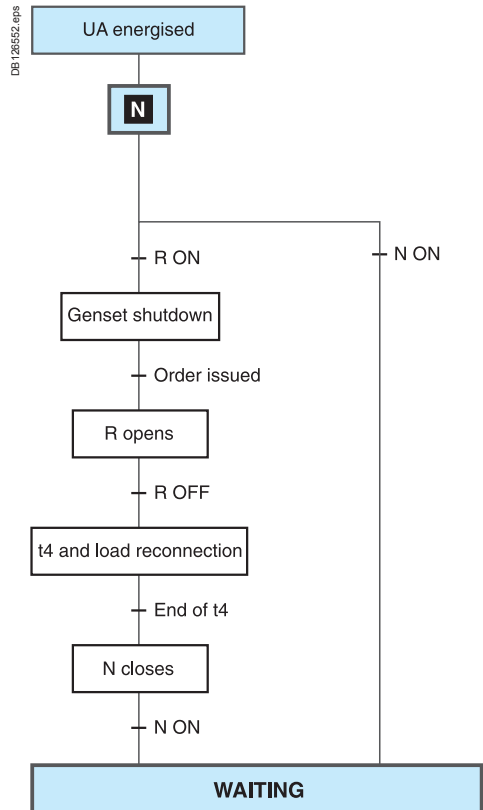

Switch set to the "Stop" position

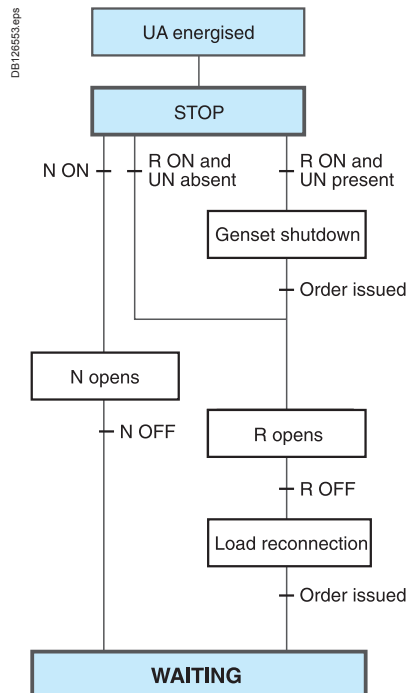

WAITING The system exits this mode when the operating mode is modified or when an external event occurs (e.g. failure or return of UN).

When the UA controller is not energised, the output for generator set startup is activated).

Key

- UN : "Normal" source voltage
- UR : "Replacement" source voltage
- N : "Normal" source circuit breaker
- R : "Replacement" source circuit breaker

Associated controllers

UA controller

Operating sequences

Special-tariff mode

Switch set to the "Auto" position (special-tariff mode)

WAITING The system exits this mode when the operating mode is modified or when an external event occurs (e.g. failure or return of UN).

When the UA controller is not energised, the output for generator set startup is activated).

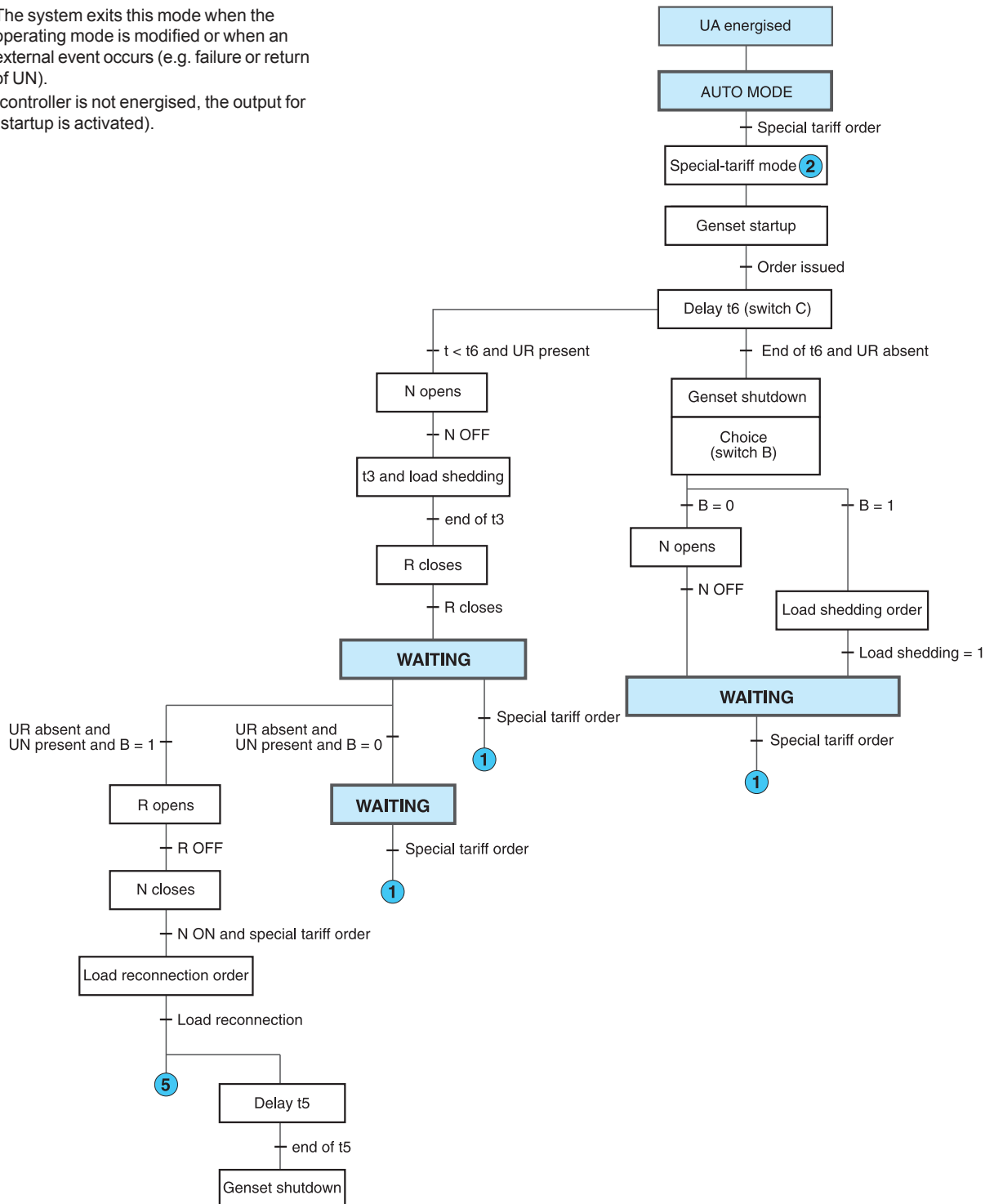

Key
 UN : "Normal" source voltage
 UR : "Replacement" source voltage
 N : "Normal" source circuit breaker
 R : "Replacement" source circuit breaker
 B : Penalties accepted (N ON), i.e. B = 1

1 The number sends to the indicated step when the condition is true.

UA controller Operating sequences Test mode and automatic operation

Switch set to the "Auto" position (automatic operation and test mode).

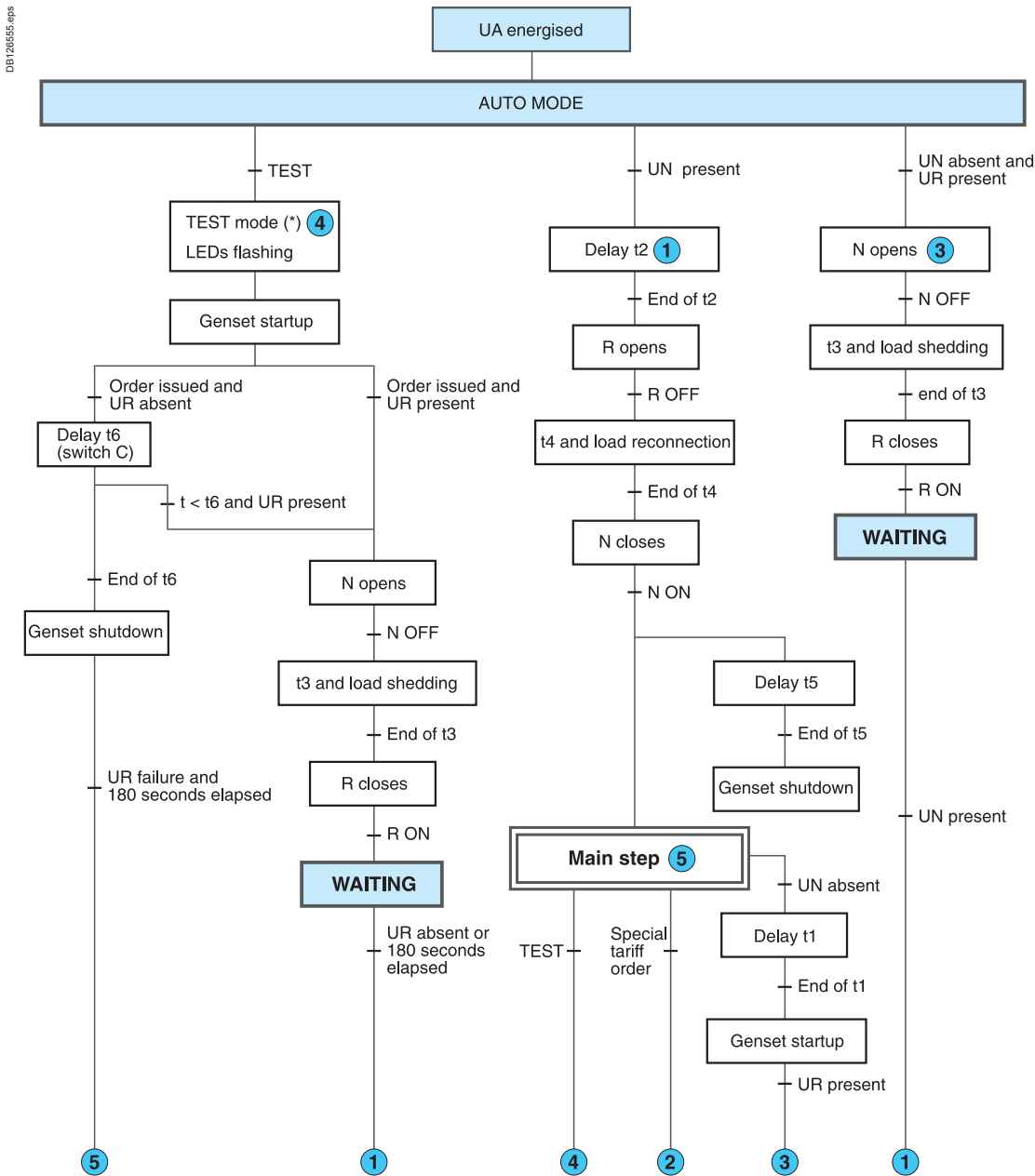

WAITING The system exits this mode when the operating mode is modified or when an external event occurs (e.g. failure or return of UN).

When the UA controller is not energised, the output for generator set startup is activated).

- Key**
- UN : "Normal" source voltage
 - UR : "Replacement" source voltage
 - N : "Normal" source circuit breaker
 - R : "Replacement" source circuit breaker
 - B : Penalties accepted (N ON), i.e. B = 1
 - (*) The test lasts 180 seconds.

① The number sends to the indicated step when the condition is true.

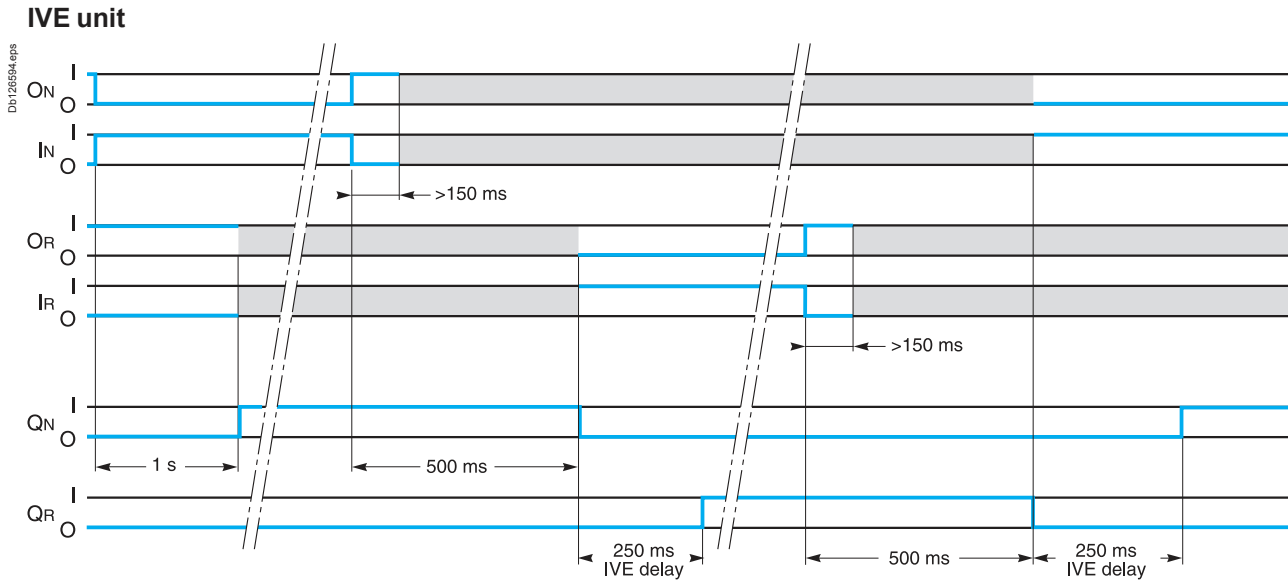

Symbols

- QN** : "Normal" Compact circuit breaker equipped for remote operation (motor mechanism)
- QR** : "Replacement" Compact circuit breaker equipped for remote operation (motor mechanism)
- ON** : Circuit breaker QN opening order
- OR** : Circuit breaker QR opening order
- IN** : Circuit breaker QN closing order
- IR** : Circuit breaker QR closing order
- L1** : Faulty "Normal" indication LED
- L2** : Faulty "Replacement" indication LED

Key

- O: OFF (circuit open)
- I: ON (circuit closed)
- : either ON or OFF.

Note: following all trips (overload, short-circuit, earth-leakage fault, voluntary trip), a manual reset on the front of the motor mechanism is required.

BA/UA controller

BA controller

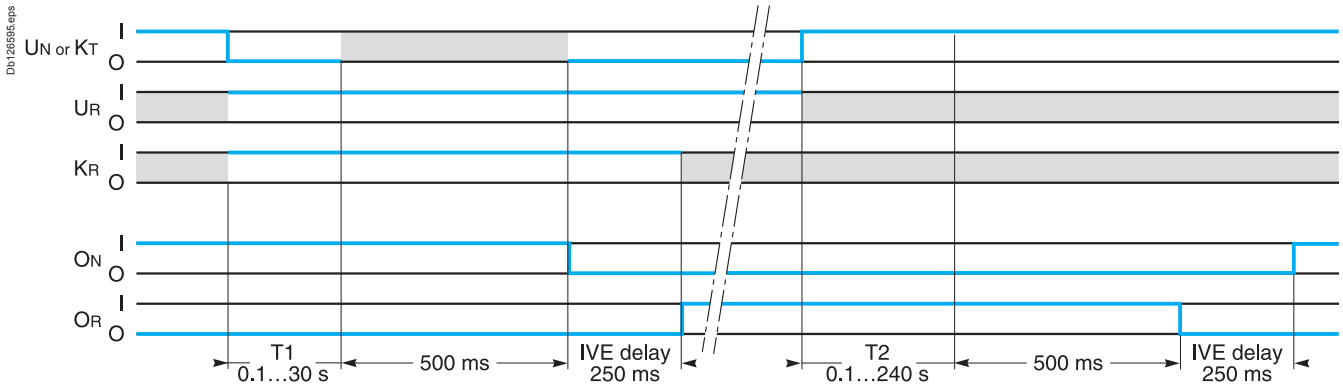

Inputs

- UN : "Normal" source voltage
- UR : "Replacement" source voltage
- KT : order for forced-operation on R
- KR : additional check before transfer

Outputs

- QN : "Normal" source circuit breaker
- QR : "Replacement" source circuit breaker

UA controller

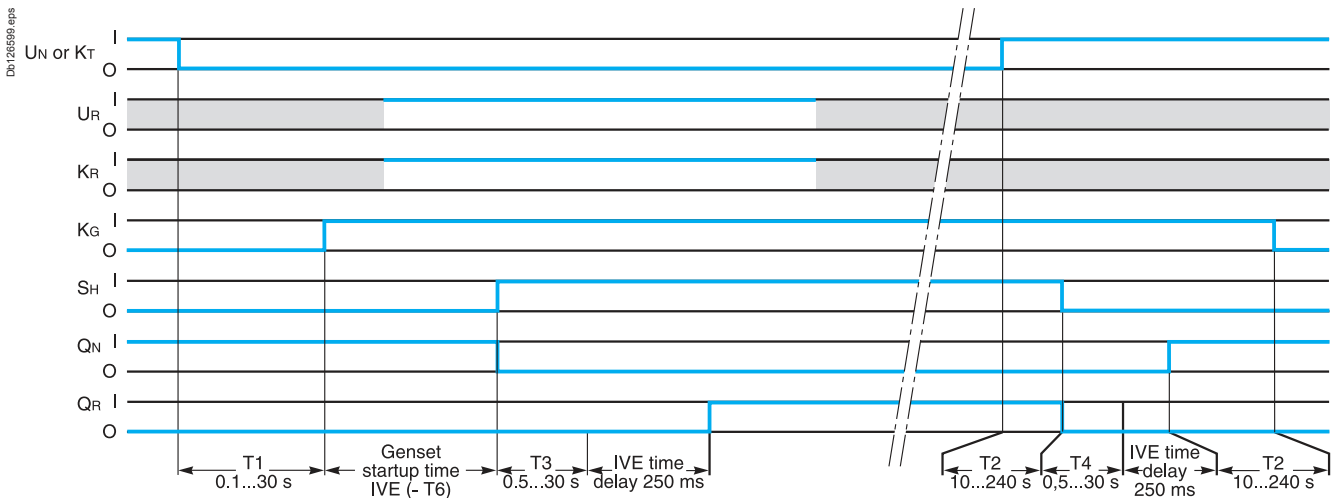

Inputs

- UN : "Normal" source voltage
- UR : "Replacement" source voltage
- KT : order for forced-operation on R
- KR : additional check before transfer

Outputs

- KG : order to the genset
- SH : load-shedding order
- QN : "Normal" source circuit breaker
- QR : "Replacement" source circuit breaker

Key

- O : OFF (circuit open)
- I : ON (circuit closed)
- : either ON or OFF

Important

If UR is not ON when the transfer order is issued (KT or UN), the sequence is not carried out. If KR status is not ON when the transfer order is issued (KT or UN), the transfer sequence is carried out later when KR status becomes I.

DB404157_aps

Electrical-installation management

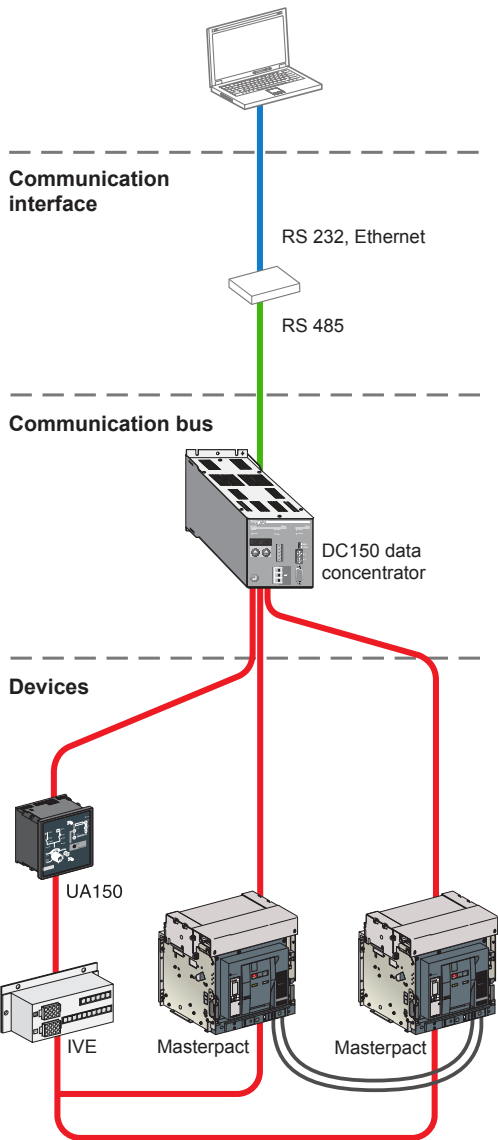

Communications option for Compact NS ≥ 630 A and Masterpact NT/NW

The COM communications option is compatible with all the source-changeover systems for Compact NS630b-1600 and Masterpact NT/NW circuit breakers and switch-disconnectors.

It can be used to remote status information. It may not be used to operate the circuit breakers (only possible locally on the front of the UA150 controller).

Masterpact and Compact NS630b to 1600 circuit breakers and switch-disconnectors are compatible with the Modbus ECO COM option.

Depending on the trip units or control units used, the COM option may also be used to analyse distribution-system parameters required for the operating and maintenance assistance.

Circuit breaker communication

| | Switch-disconnector | Circuit breaker |
|---|---------------------|-----------------|
| Compact NS630b-1600 status indications | | |
| ON / OFF | ■ | ■ |
| Fault trip | | ■ |
| Connected / disconnected position | ■ | ■ |
| Masterpact NT/NW status indications | | |
| ON / OFF | ■ | ■ |
| Fault trip | | ■ |
| Connected / disconnected position | ■ | ■ |

Operating and maintenance assistance

| Operating and maintenance aids | Modbus | | | |
|---------------------------------------|--------|---|---|---|
| Measurement | | | | |
| Current | A | E | P | H |
| Voltages, power... | | E | P | H |
| Frequency | | | P | H |
| Power quality: fundamental, harmonics | | | | H |
| Programming of demand metering | | E | P | H |
| Fault readings | | | | |
| Type of fault | A | E | P | H |
| Interrupted current | | | P | H |
| Waveform capture | | | | |
| On faults | | | | H |
| On demand or programmed | | | | H |
| Histories and logs | | | | |
| Trip history | | E | P | H |
| Alarm history | | | P | H |
| Event logs | | | P | H |
| Indicators | | | | |
| Counter operation | A | E | P | H |
| Contact wear | | | P | H |
| Maintenance register | | | P | H |

Note: see the description of the Micrologic control units for further details on protection and alarms, measurements, waveform capture, histories, logs and maintenance indicators.

COM communications option

| Controller | UA150 |
|---|-------|
| Status indications | |
| “Normal” source | |
| ON / OFF | ■ |
| Circuit breaker ON | ■ |
| Fault trip (SDE) | ■ |
| Voltage presence | ■ |
| “Replacement” source | |
| Circuit breaker ON | ■ |
| Fault trip (SDE) | ■ |
| Voltage presence | ■ |
| Status of R voltage contact | ■ |
| Controller | |
| Automatic mode | ■ |
| “Normal” mode | ■ |
| “Replacement” mode | ■ |
| Stop mode | ■ |
| Testing | ■ |
| “Replacement” engine generator set | |
| Genset failure | ■ |
| Genset OFF | ■ |
| Genset ON | ■ |
| Shedding of non-priority circuits | ■ |
| Reconnection of non-priority circuits | ■ |
| Settings | |
| Time delay t1 for validation of UN absence | ■ |
| Time delay t2 for validation of UN return | ■ |
| Time delay t3 for wait between opening of N and closing of R | ■ |
| Time delay t4 for wait between opening of R and closing of N | ■ |
| Time delay t5 for wait between return of UN and order for genset shutdown | ■ |
| Time delay t6 for wait before declaring genset failure | ■ |
| Penalties accepted to avoid special tariff transfer | ■ |

DB640074.eps

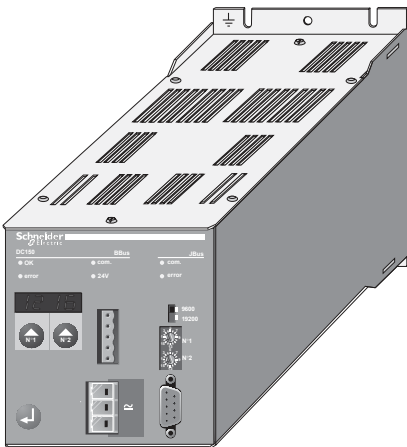

DC150 data concentrator

The DC150 data concentrator is designed to centralise the information provided by the communicating switchgear of the Digipact range and to make this information accessible to a supervisor or PLC under the MODBUS/JBUS protocol.

Main characteristics

- Power supply:
110 V AC to 240 V AC
115 V DC to 125 V DC.
- Weight: 1.5 kg.
- Installation: on panel with the DC150 box which must be earthed on metal part of the installation.
- Over dimensions H x W x D (mm): 138.5 x 100 x 192.8.

schneider-electric.com

This international site allows you to access all the Schneider Electric Solution and Product information via :

- comprehensive descriptions
- range data sheets
- a download area
- product selectors
- ...

You can also access the information dedicated to your business and get in touch with your Schneider Electric country support.



| | |
|--|------|
| <i>Presentation</i> | 2 |
| <i>Functions and characteristics</i> | A-1 |
| Manual source-changeover systems | |
| Interlocking of direct rotary handles | B-2 |
| Interlocking of extended rotary handles | B-3 |
| Interlocking of toggles | B-5 |
| Complete source-changeover assembly | B-6 |
| Downstream coupling accessory | B-7 |
| Remote-operated source-changeover systems | |
| Interlocking on a base plate | B-9 |
| Interlocking using connecting rods | B-13 |
| Interlocking using cables | B-15 |
| IVE unit, BA and UA automatic controllers | B-20 |
| <i>Electrical diagrams</i> | C-1 |
| <i>Catalogue numbers and order forms</i> | D-1 |

Manual source-changeover systems

Interlocking of direct rotary handles

Compact NSX100 to 630

Dimensions

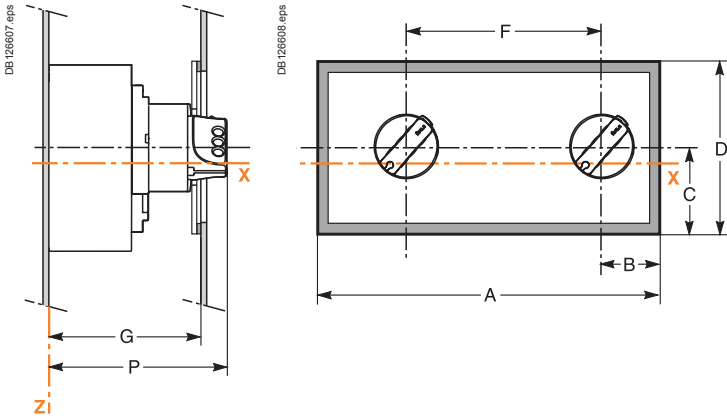

Front-panel cutout

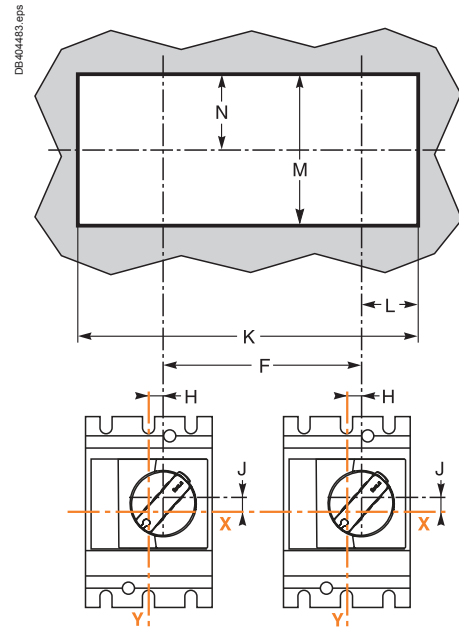

Dimensions (mm)

| | A | B | C | D | F | G | H | J | K | L | M | N | P |
|----------------|-----|-----|------|-----|-----|-----|------|------|-----|------|-----|------|-----|
| NSX100/160/250 | 325 | 90 | 87.5 | 175 | 156 | 133 | 9.25 | 9 | 295 | 75.5 | 150 | 75 | 155 |
| NSX400/630 | 416 | 115 | 100 | 200 | 210 | 157 | 5 | 24.6 | 386 | 100 | 175 | 74.5 | 179 |

Compact INS/INV250 - 100 to 250 / Compact INS/INV320/400/500/630

Dimensions

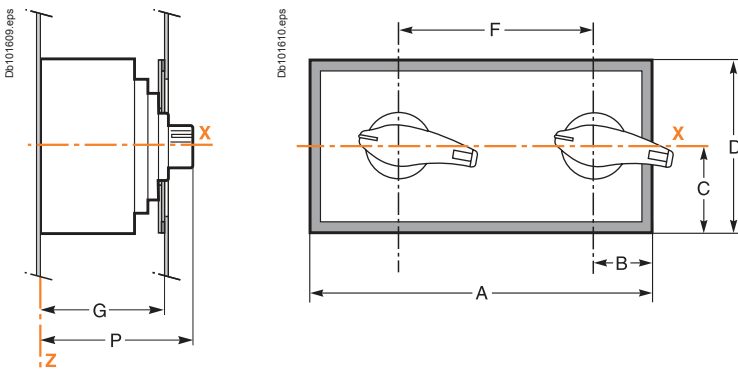

Front-panel cutout

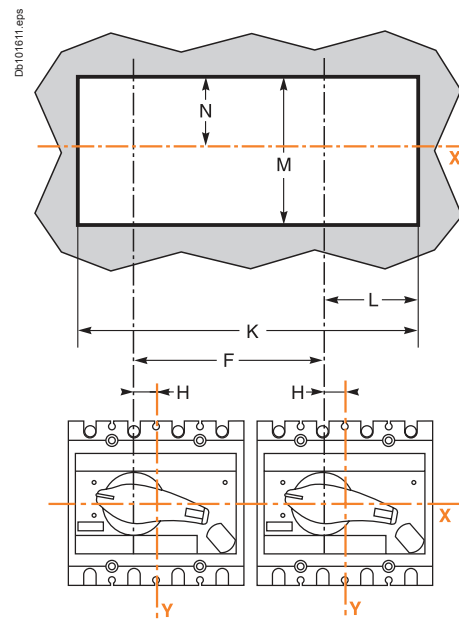

Dimensions (mm)

| Type | A | B | C | D | F | G | H | K | L | M | N | P |
|------------------------------|-----|-----|------|-----|-----|-----|------|-----|------|-----|------|-------|
| INS/INV250 - 100/160/200/250 | 325 | 90 | 87.5 | 175 | 156 | 106 | 17.5 | 295 | 75.5 | 150 | 75 | 131 |
| INS/INV320/400/500/630 | 416 | 115 | 100 | 200 | 210 | 130 | 22.5 | 386 | 100 | 175 | 74.5 | 160.4 |

Note: X and Y are the symmetry planes for a 3-pole device.

Interlocking of extended rotary handles

Compact NSX100 to 630

Dimensions

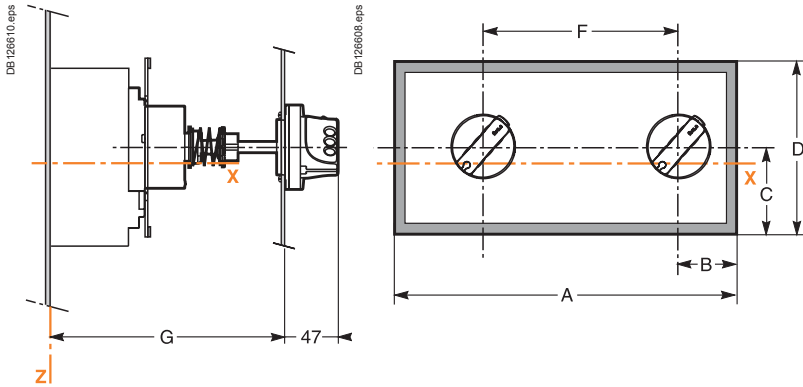

Front-panel cutout

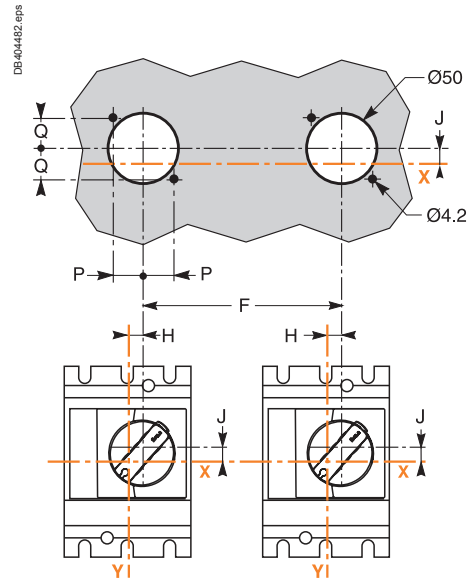

Dimensions (mm)

| Type | A | B | C | D | F | G min | G max | H | J | P | Q |
|----------------|-----|-----|------|-----|-----|-------|-------|------|------|------|------|
| NSX100/160/250 | 325 | 90 | 87.5 | 175 | 156 | 171 | 600 | 9.25 | 9 | 25.5 | 25.5 |
| NSX400/630 | 416 | 115 | 100 | 200 | 210 | 195 | 600 | 5 | 24.6 | 30.8 | 30.8 |

Compact INS40/63/80/100/125/160 / Compact INS/INV250 - 100 to 250 / Compact INS/INV320/400/500/630

Dimensions

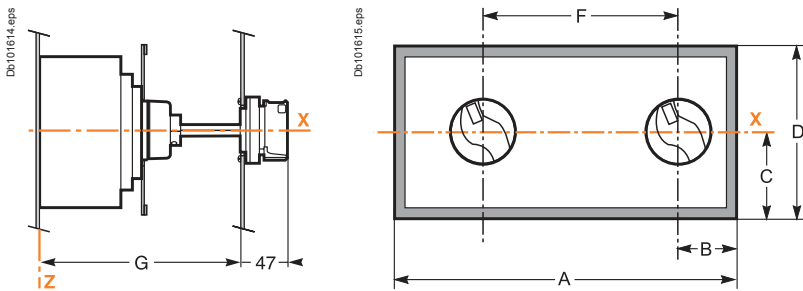

Front-panel cutout

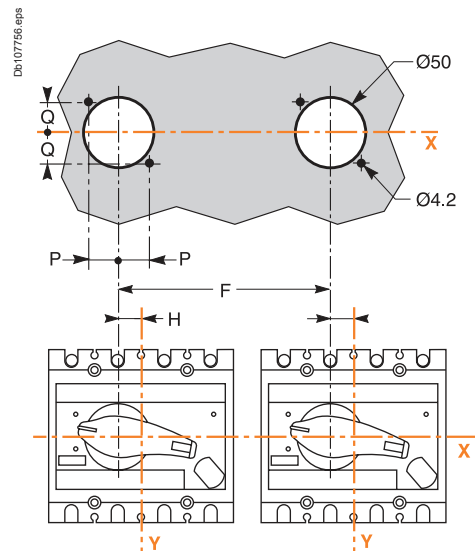

Dimensions (mm)

| Type | A | B | C | D | F | G min | G max | H | P | Q |
|------------------------------|-----|-----|------|-----|-----|-------|-------|------|------|------|
| INS40/63/80 | 325 | 90 | 87.5 | 175 | 156 | 155 | 396 | 0 | 25.5 | 25.5 |
| INS100/125/160 | 325 | 90 | 87.5 | 175 | 156 | 200 | 441 | 0 | 25.5 | 25.5 |
| INS/INV250 - 100/160/200/250 | 325 | 90 | 87.5 | 175 | 156 | 185 | 600 | 17.5 | 25.5 | 25.5 |
| INS320/400/500/630 | 416 | 115 | 100 | 200 | 210 | 204 | 600 | 22.5 | 30.8 | 30.8 |

Manual source-changeover systems

Interlocking of extended rotary handles

Compact NS630b to 1600

Dimensions

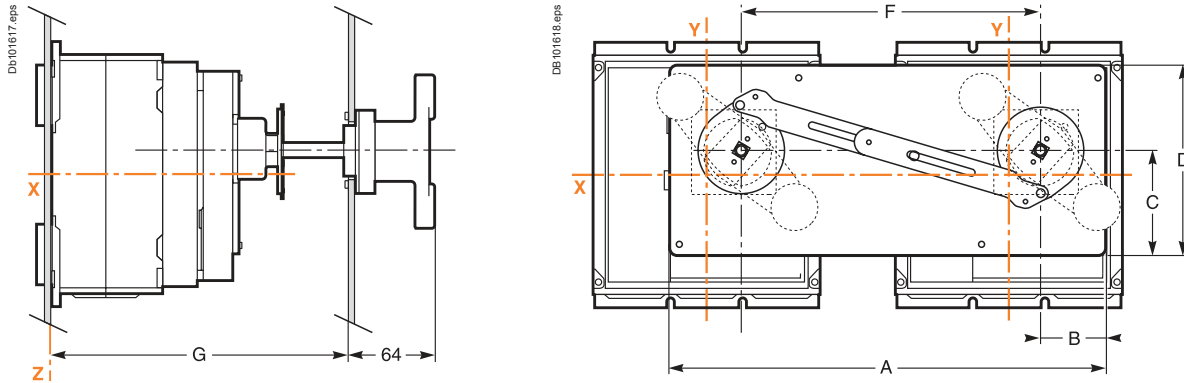

Front-panel cutout

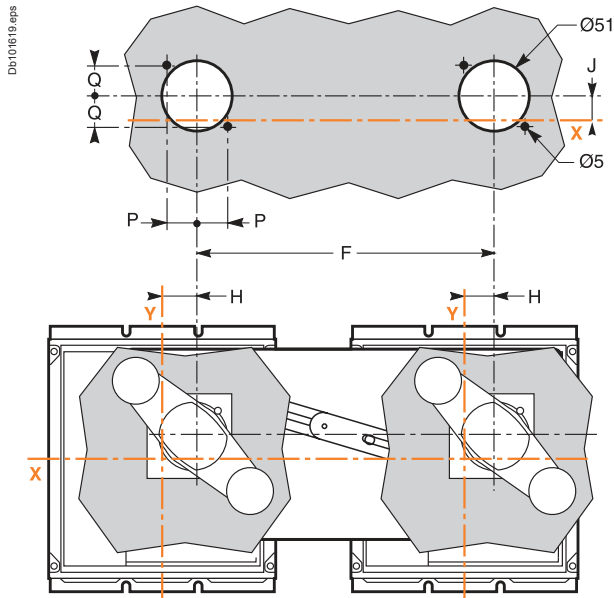

Dimensions (mm)

| Type | A | B | C | D | F | G min | G max | H | J | P | Q | R |
|---------------------------|-----|------|----|-----|-----|-------|-------|----|----|------|------|----|
| NS630b/800/1000/1200/1600 | 411 | 63.5 | 98 | 175 | 280 | 218 | 605 | 25 | 24 | 25.5 | 25.5 | 64 |

Interlocking of toggles

Compact NSX100 to 630

Dimensions

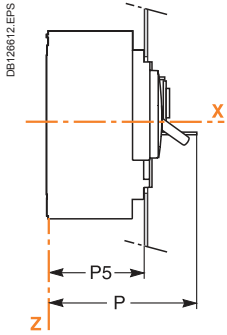

3 poles

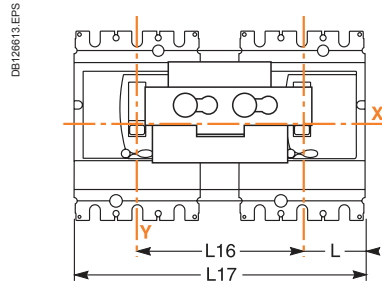

4 poles

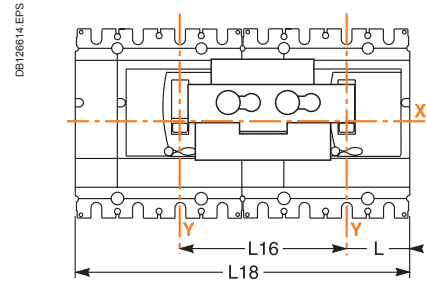

Front-panel cutout

3 poles on left

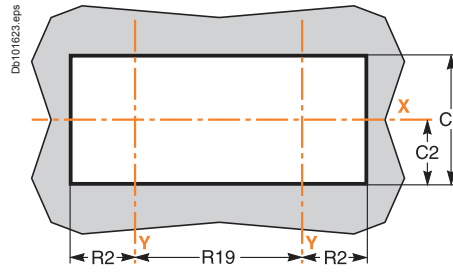

4 poles on left

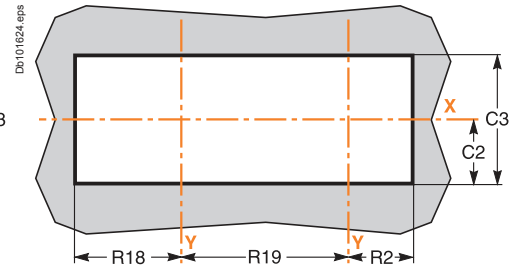

Dimensions (mm)

| Type | C2 | C3 | L | L16 | L17 | L18 | R2 | R18 | R19 | P5 | P |
|----------------|------|-----|------|-----|-----|-----|------|-------|-----|-----|-----|
| NSX100/160/250 | 54 | 108 | 52.5 | 140 | 245 | 280 | 54 | 89 | 140 | 83 | 120 |
| NSX400/630 | 92.5 | 182 | 70 | 185 | 325 | 370 | 71.5 | 116.5 | 185 | 107 | 150 |

Manual source-changeover systems

Complete source-changeover assembly

Assembly for INS250 - 100 to 250 / Assembly for INS320/400/500/630

Dimensions

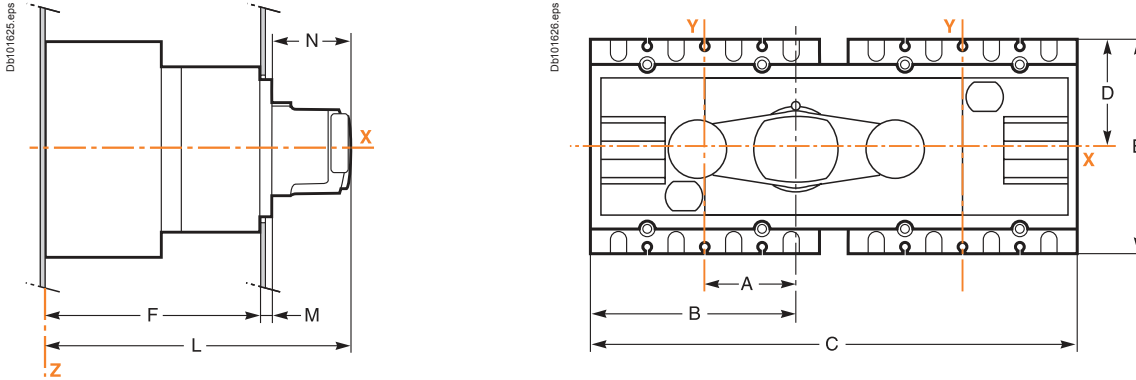

Front-panel cutout

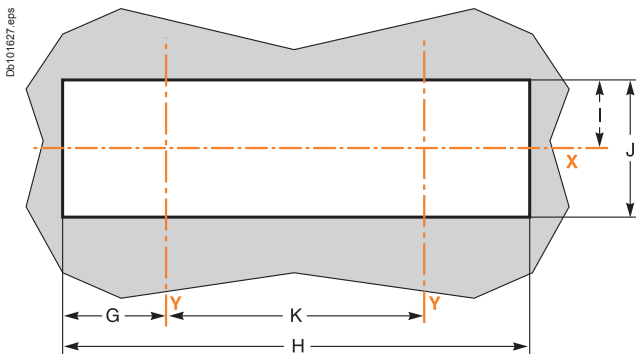

Dimensions (mm)

| Type | A | B | C | D | E | F | G | H | I | J | K | L | M | N |
|--------------------------|------|-------|-----|-------|-----|-----|------|-------|----|-----|-----|-------|-----|----|
| INS250 - 100/160/200/250 | 60.4 | 130.4 | 296 | 68 | 136 | 131 | 61.8 | 279.3 | 42 | 84 | 156 | 186.5 | 5.5 | 50 |
| INS320/400/500/630 | 82.5 | 175 | 395 | 102.5 | 205 | 155 | 87 | 383.7 | 64 | 128 | 210 | 213 | 8 | 50 |

Dimensions of the complete source-changeover assembly with an extended handle

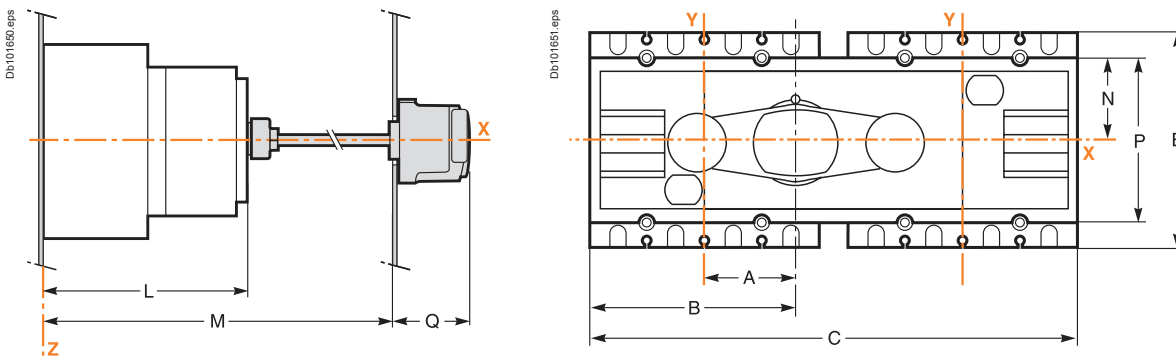

Dimensions (mm)

| Type | A | B | C | E | K | L | M | N |
|--------------------------|------|-------|-----|-----|-----|-------|-----|----|
| INS250 - 100/160/200/250 | 60.4 | 130.4 | 295 | 136 | 156 | 138.5 | 631 | 50 |
| INS320/400/500/630 | 82.5 | 175 | 395 | 205 | 210 | 162.5 | 658 | 75 |

Dimensions (mm)

| Type | P | Mmax | Mmin | Q |
|--------------------------|-----|-------|-------|----|
| INS250 - 100/160/200/250 | 100 | 567.5 | 195 | 64 |
| INS320/400/500/630 | 150 | 593 | 220.5 | 64 |

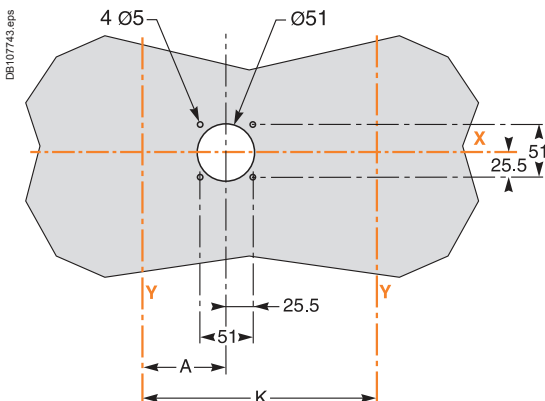

Note: lines X and Y indicate the axes of symmetry of the switch-disconnector. Reference plane Z corresponds to the back of the switch-disconnector.

Downstream coupling accessory

Compact NSX100 to NSX630 (only for Compact NSX fixed devices)

Dimensions

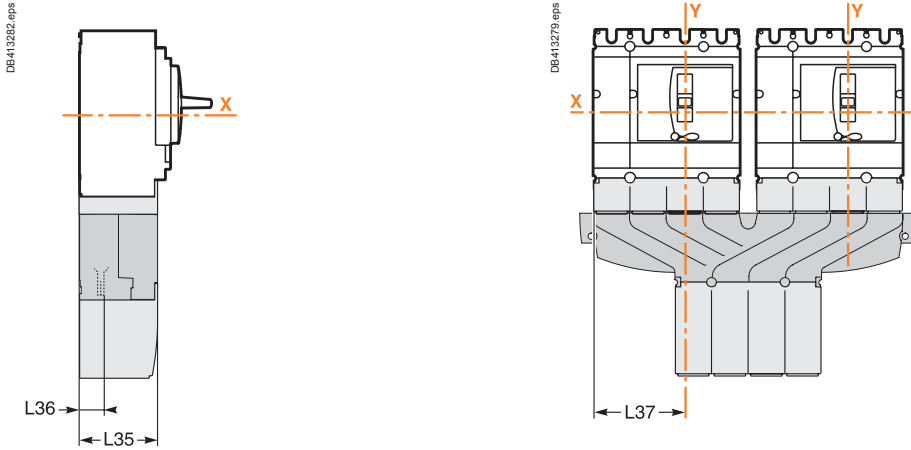

Dimensions

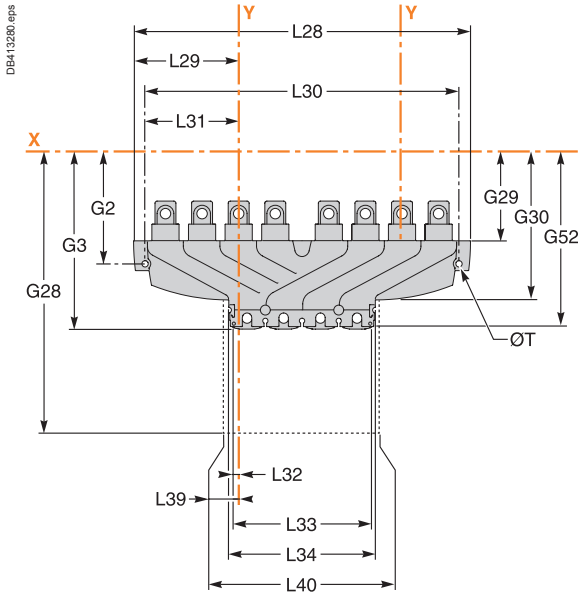

Connection

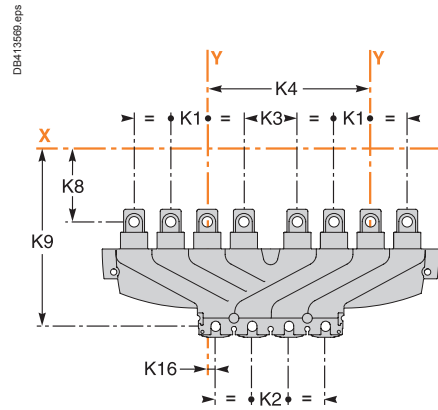

Dimensions (mm)

| Type | G2 | G3 | G28 | G29 | G30 | G52 | K1 | K2 | K3 | K4 | K8 | K9 | K16 |
|----------------|-------|-------|-------|-------|-------|-------|----|----|----|-----|-------|-------|-----|
| NSX100/160/250 | 118 | 181.5 | 244.5 | 96 | 152.5 | 178 | 35 | 35 | 51 | 156 | 70 | 170 | 8 |
| NSX400/630 | 165.9 | 264.7 | 337.5 | 143.5 | 220.5 | 264.7 | 45 | 45 | 75 | 210 | 113.5 | 250.7 | 15 |

Dimensions (mm)

| Type | L28 | L29 | L30 | L31 | L32 | L33 | L34 | L35 | L36 | L37 | L39 | L40 | ØT |
|----------------|-----|------|-----|-------|------|-------|-------|------|------|------|------|-------|----|
| NSX100/160/250 | 320 | 99.5 | 300 | 89.5 | 4.73 | 130.5 | 139.5 | 74.5 | 19.5 | 87.5 | 9.5 | 140 | 6 |
| NSX400/630 | 425 | 130 | 400 | 117.5 | 5.15 | 175.3 | 184.7 | 98.5 | 26 | 115 | 9.85 | 184.7 | 6 |

Note: coupling accessory: only for changeover systems using fixed versions of Compact NSX circuit breakers.

Compact INS250 - 100 to 250 / Compact INS320/400/500/630

Dimensions

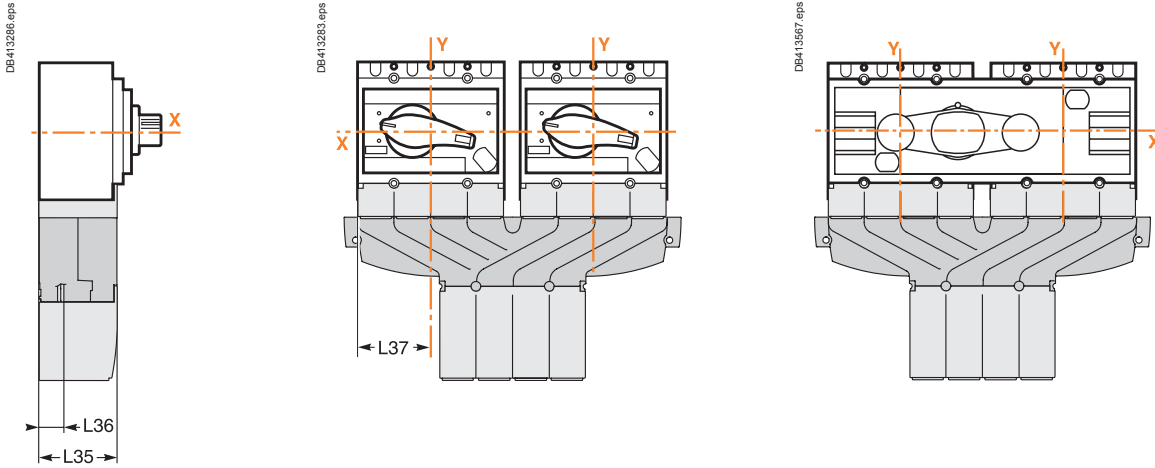

Dimensions

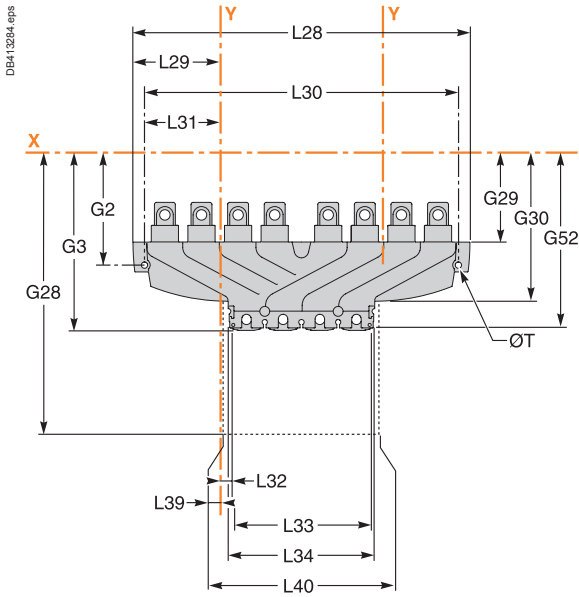

Connection

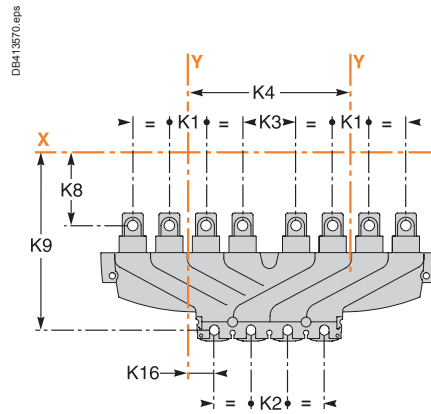

Dimensions (mm)

| Type | G2 | G3 | G28 | G29 | G30 | G52 | K1 | K2 | K3 | K4 | K8 | K9 | K16 |
|------------------------|-------|-------|-----|------|-------|-------|----|----|----|-----|------|-------|------|
| INS250-100/160/200/250 | 105.5 | 169 | 232 | 83.5 | 140 | 165.5 | 35 | 35 | 51 | 156 | 57.5 | 157.5 | 25.5 |
| INS320/400/500/630 | 141 | 240.7 | 313 | 119 | 195.6 | 240 | 45 | 45 | 75 | 210 | 88.5 | 225.7 | 37.5 |

Dimensions (mm)

| Type | L28 | L29 | L30 | L31 | L32 | L33 | L34 | L35 | L36 | L37 | L39 | L40 | ØT |
|------------------------|-----|-------|-----|-----|-------|-------|-------|------|------|------|-------|-------|----|
| INS250-100/160/200/250 | 320 | 83 | 300 | 72 | 12.8 | 130.5 | 139.5 | 74.5 | 21.5 | 70 | 8.5 | 140 | 6 |
| INS320/400/500/630 | 425 | 107.5 | 400 | 95 | 17.35 | 175.3 | 184.7 | 98.5 | 26 | 92.5 | 12.65 | 184.7 | 6 |

Remote-operated source-changeover systems

Interlocking on a base plate

Compact NSX100 to 250

Dimensions, 3 or 4 poles

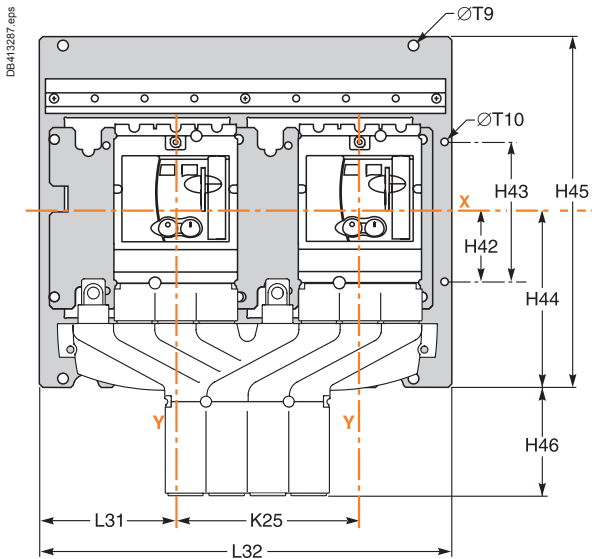

Fixed device

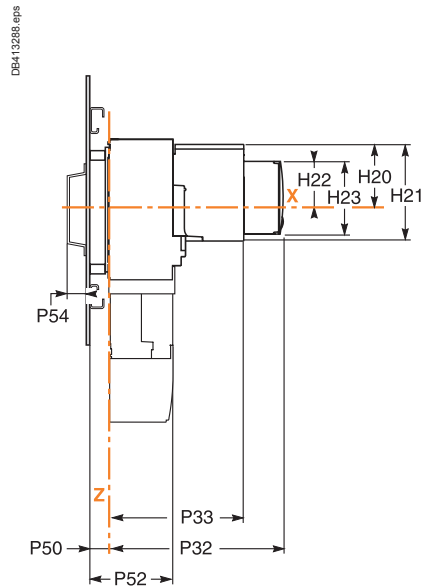

Withdrawable device

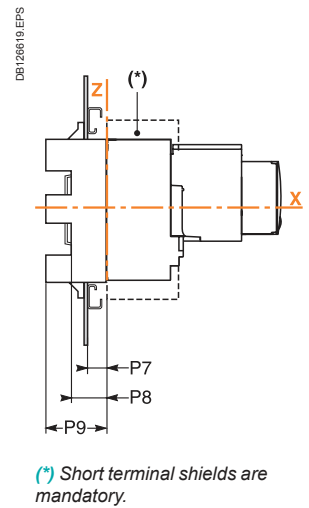

Vertical mounting

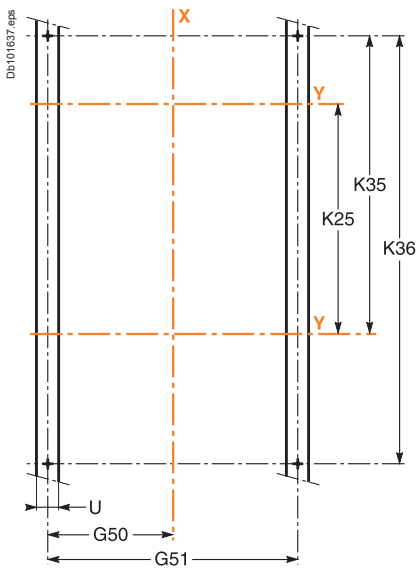

Horizontal mounting

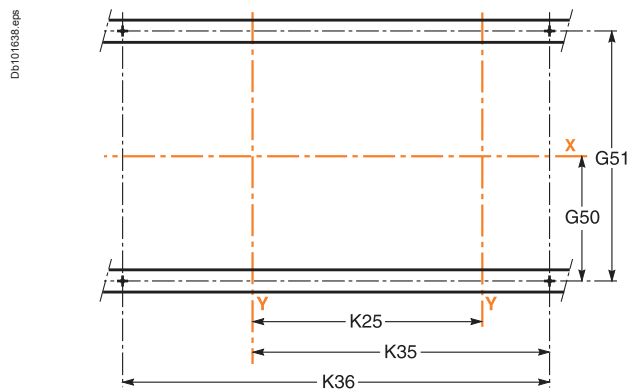

Dimensions (mm)

| Type | G50 | G51 | H20 | H21 | H22 | H23 | H42 | H43 | H44 | H45 | H46 | K25 | K35 | K36 |
|----------------|-------|-----|------|-----|------|-----|-----|-----|-------|-----|-----|-----|-------|-----|
| NSX100/160/250 | 137.5 | 285 | 62.5 | 97 | 45.5 | 73 | 60 | 120 | 144.5 | 300 | 37 | 156 | 210.5 | 300 |
| NSX400/630 | 180 | 360 | 100 | 152 | 83 | 123 | 60 | 120 | 189 | 378 | 77 | 210 | 282.5 | 400 |

Dimensions (mm)

| Type | L31 | L32 | P7 | P8 | P9 | P32 | P33 | P50 | P52 | P54 | ØT9 | ØT10 | U |
|----------------|-------|-----|----|----|-----|-----|-----|-----|------|-----|-----|------|------|
| NSX100/160/250 | 110.5 | 354 | 25 | 45 | 75 | 182 | 143 | 25 | 99.5 | 21 | 9 | 6 | ≤ 32 |
| NSX400/630 | 150.5 | 466 | 25 | 45 | 100 | 256 | 215 | 25 | 123 | 21 | 9 | 6 | ≤ 32 |

Note: coupling accessory: only for changeover systems using fixed versions of Compact NSX circuit breakers.

Remote-operated source-changeover systems

Interlocking on a base plate

Compact NSX400 to 630

Dimensions, 3 or 4 poles

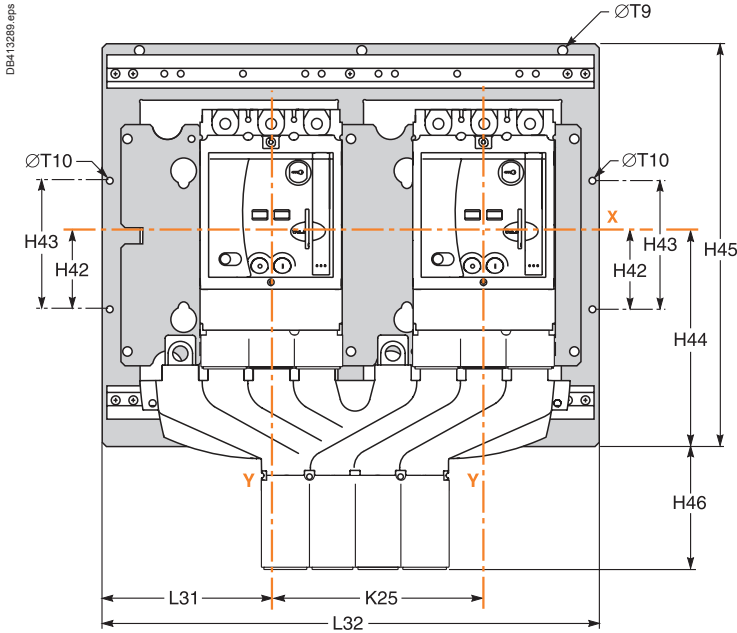

Fixed device

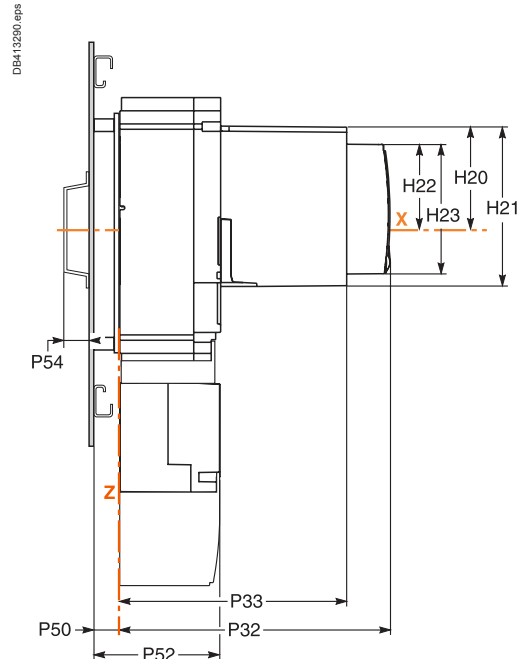

Withdrawable device

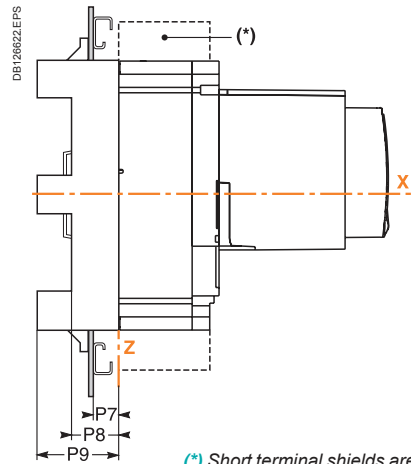

Note: coupling accessory: only for changeover systems using fixed versions of Compact NSX circuit breakers.

Dimensions

Vertical mounting

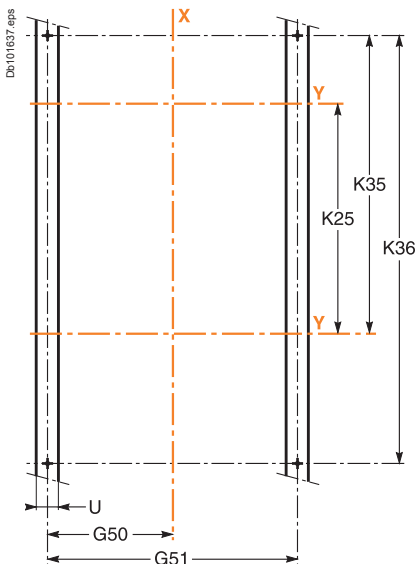

Horizontal mounting

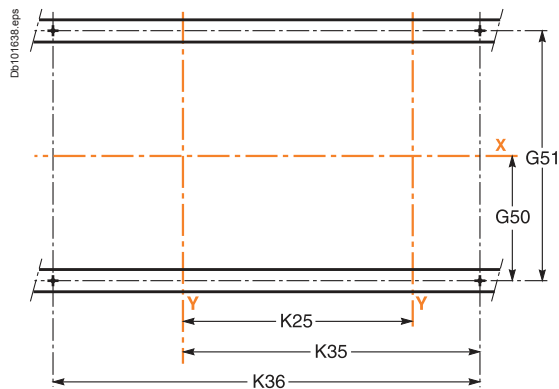

(*) Short terminal shields are mandatory.

Note: dimensions see page B-9.

“Normal” and “Replacement” source devices: NSX100 to NSX250

Dimensions

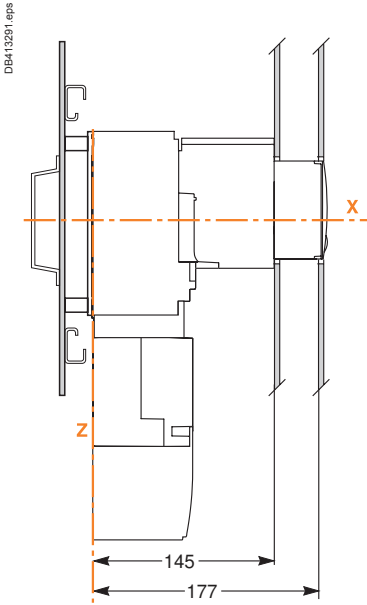

Front-panel cutout

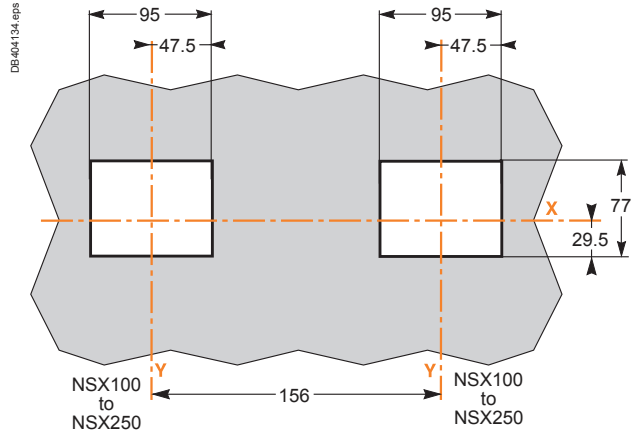

“Normal” and “Replacement” source devices: NSX400 to NSX630

Dimensions

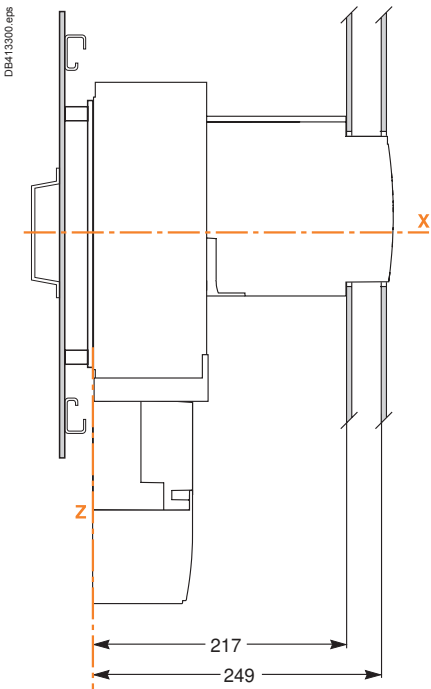

Front-panel cutout

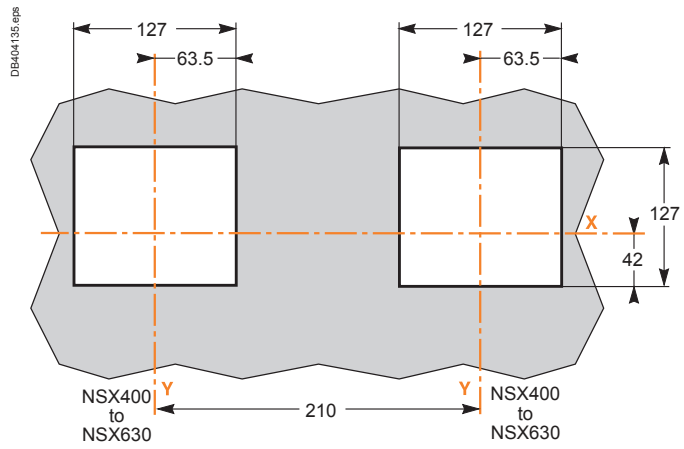

Note for Compact NSX:

For dimensions with the accessories (IP40 escutcheons and Vigi escutcheon protection collars), see Catalogue Compact.

Remote-operated source-changeover systems

Interlocking on a base plate

NSX400 to NSX630 as the "Normal" device, NSX100 to NSX250 as the "Replacement" device

Dimensions

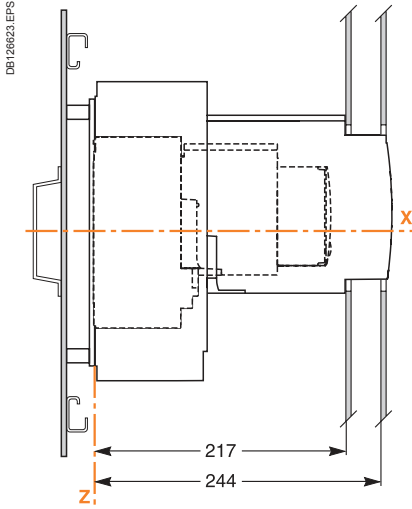

Front-panel cutout

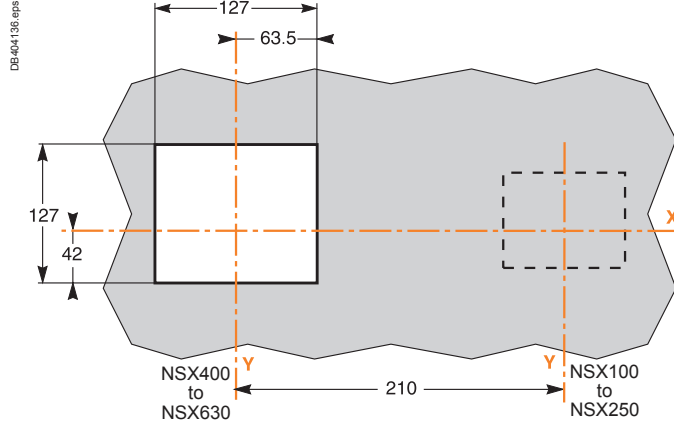

Interlocking using connecting rods

Two Compact NS630b to NS1600 devices one above the other

Fixed devices

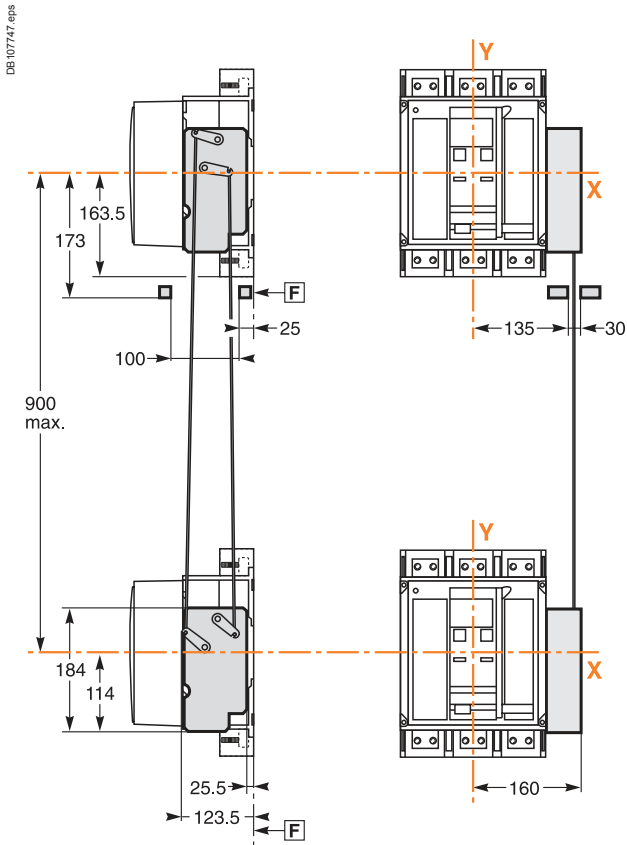

Withdrawable devices

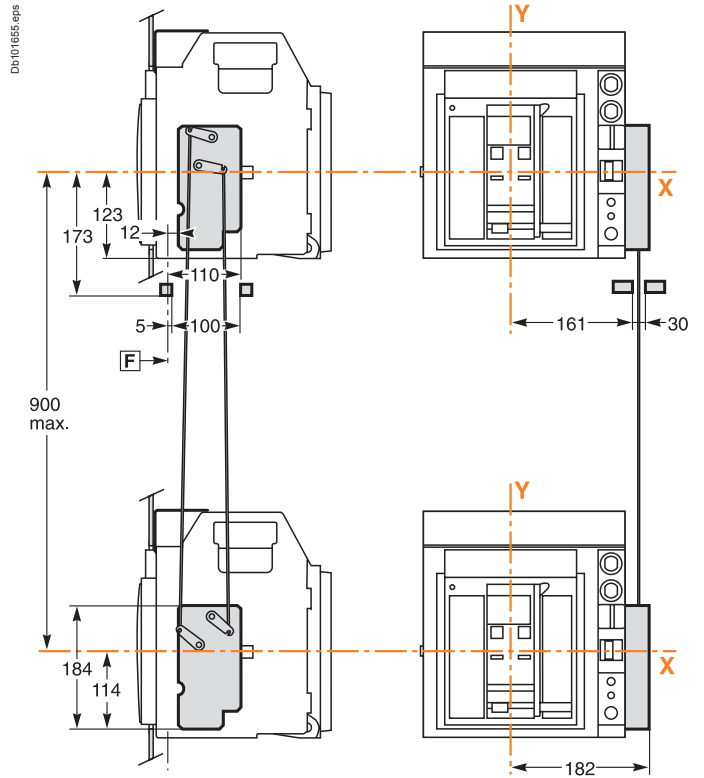

Two Masterpact NT devices one above the other

Fixed devices

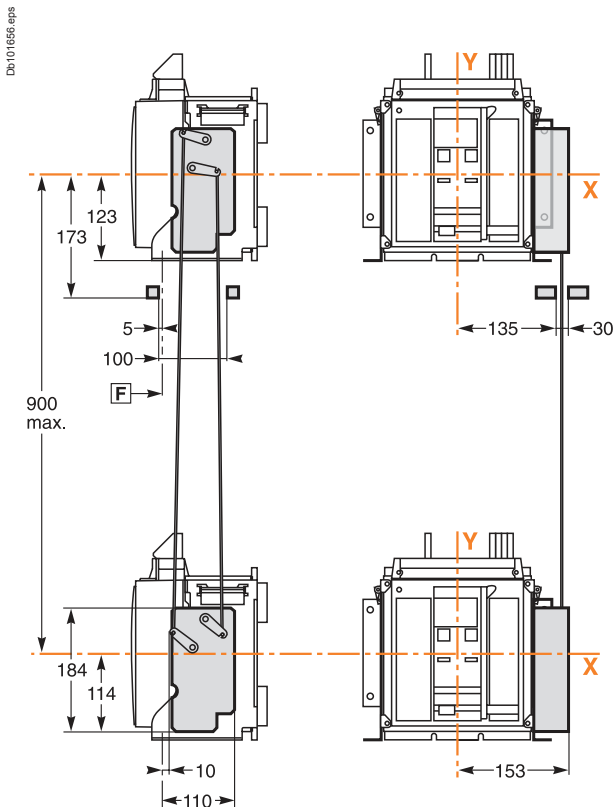

Withdrawable devices

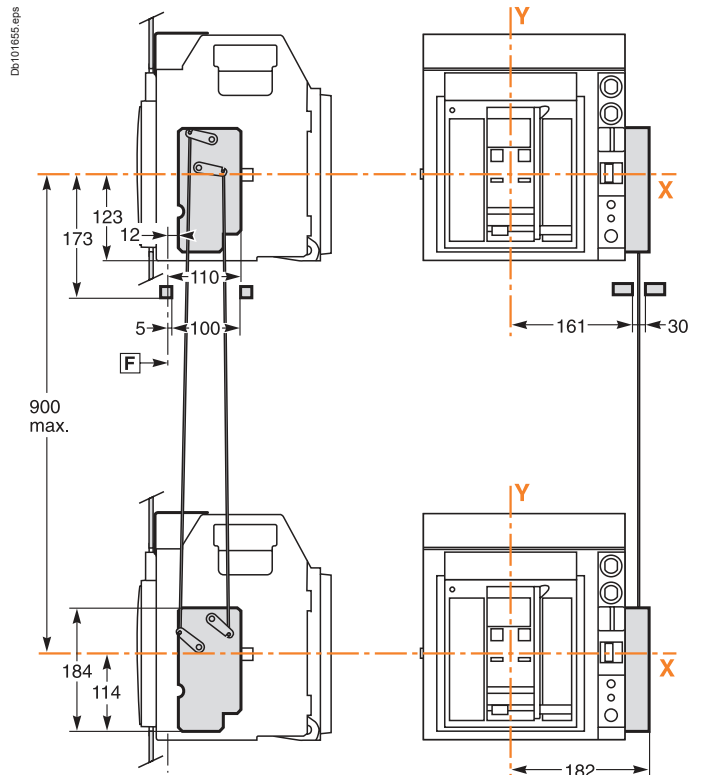

Remote-operated source-changeover systems

Interlocking using connecting rods

Two Masterpact NW devices one above the other

Fixed devices

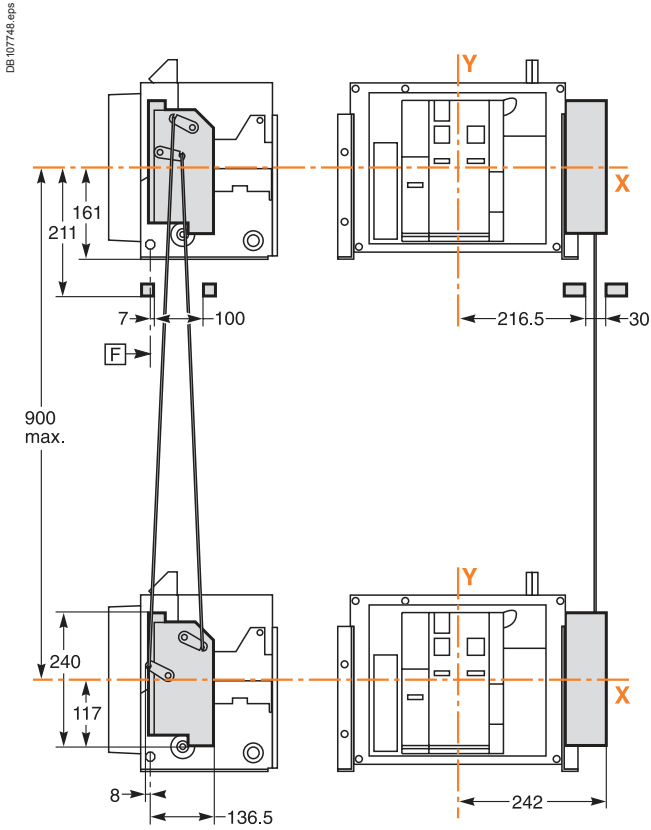

Withdrawable devices

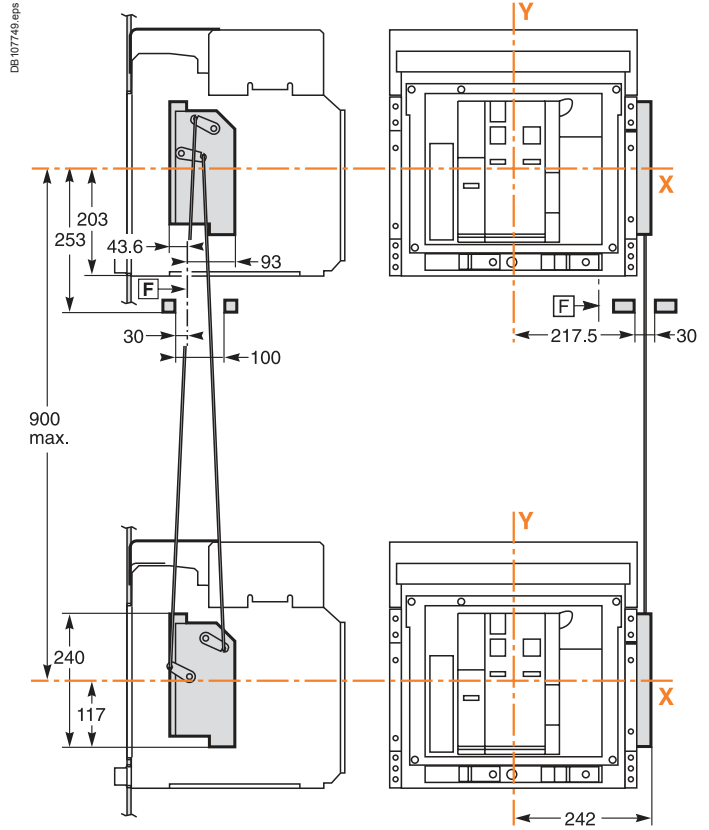

Interlocking using cables

Two Compact NS630b to NS1600 devices side-by-side

Fixed devices

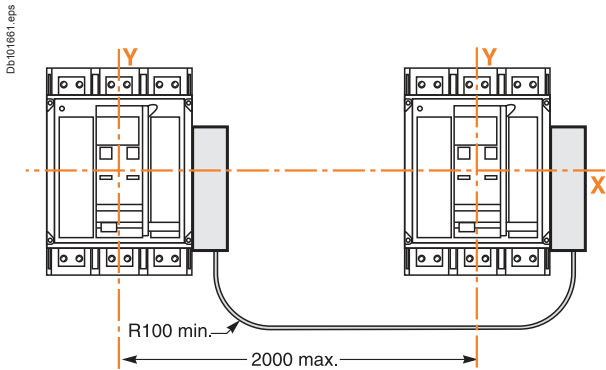

Withdrawable devices

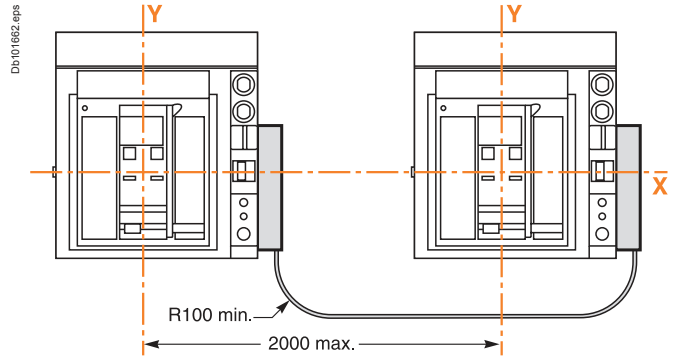

Two Masterpact NT devices side-by-side

Fixed devices

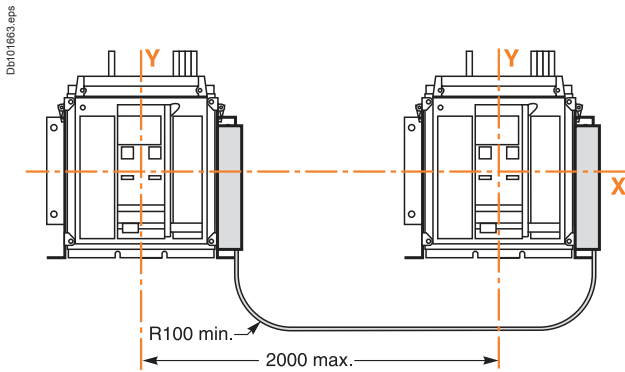

Drawout devices

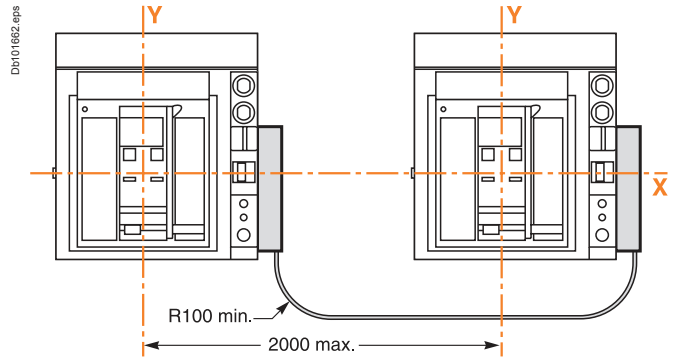

Combination of two Masterpact NT and NW devices side-by-side

Fixed devices

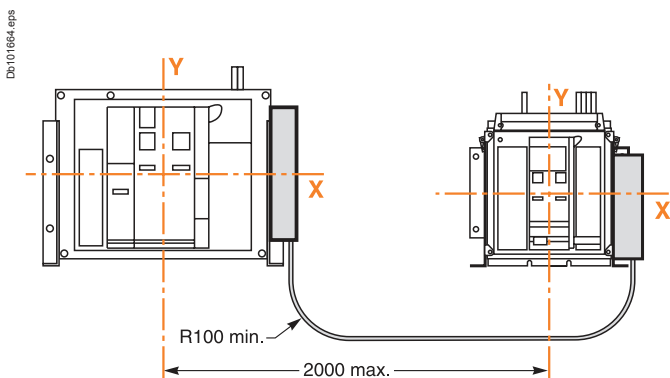

Drawout devices

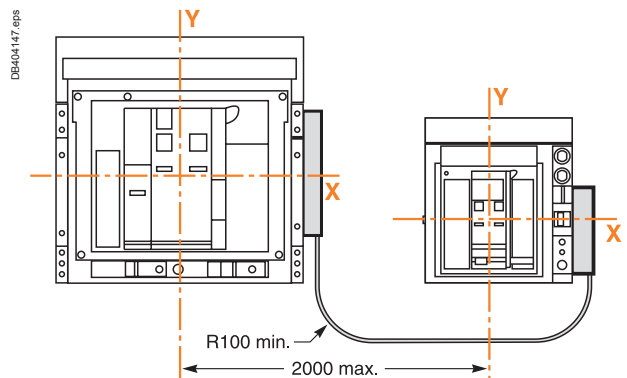

Remote-operated source-changeover systems

Interlocking using cables

Two Masterpact NW devices side-by-side

Fixed devices

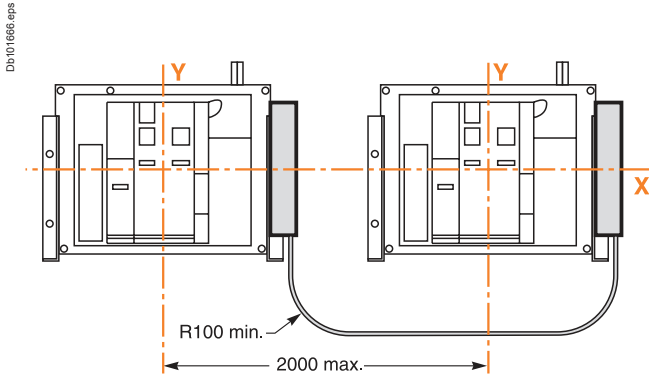

Drawout devices

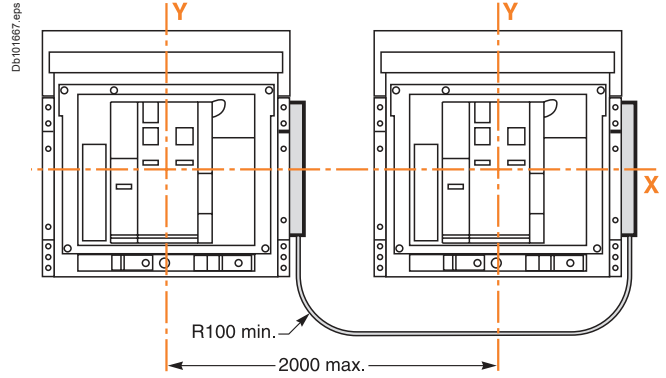

Three Masterpact NW devices side-by-side

Fixed devices

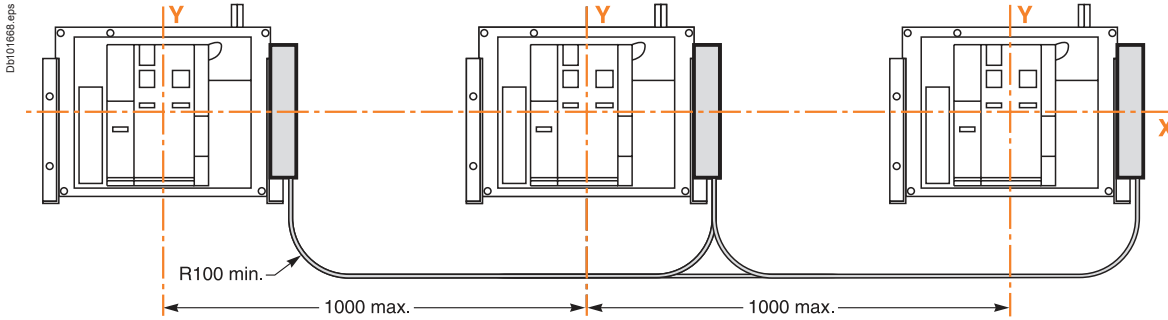

Drawout devices

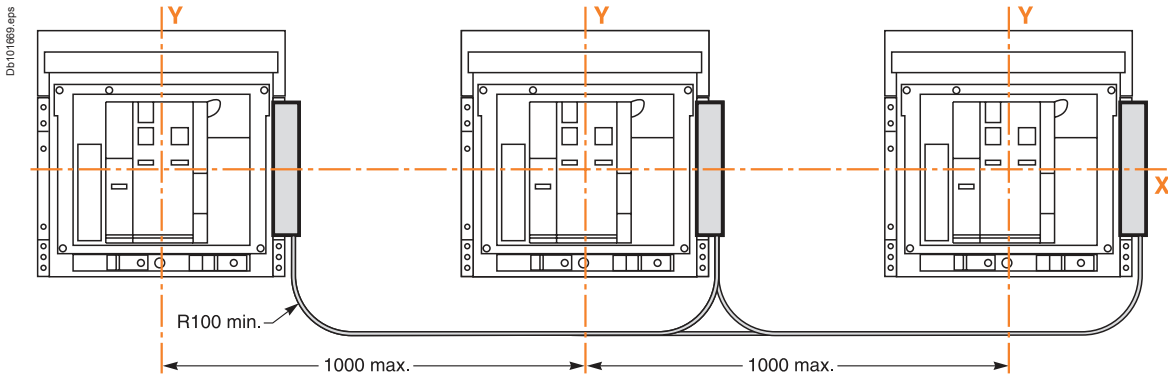

Two Compact NS630b to NS1600 devices one above the other

Fixed devices

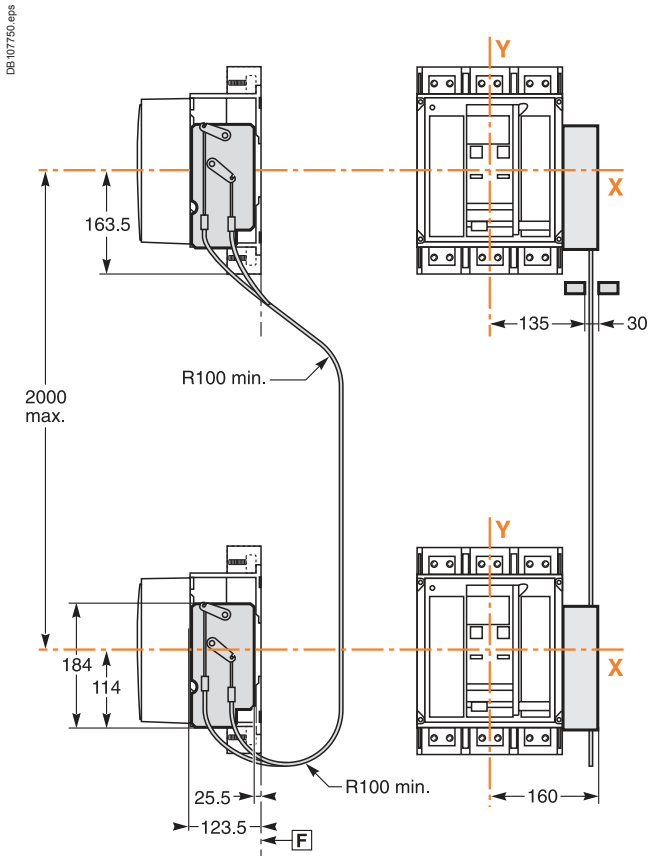

Withdrawable devices

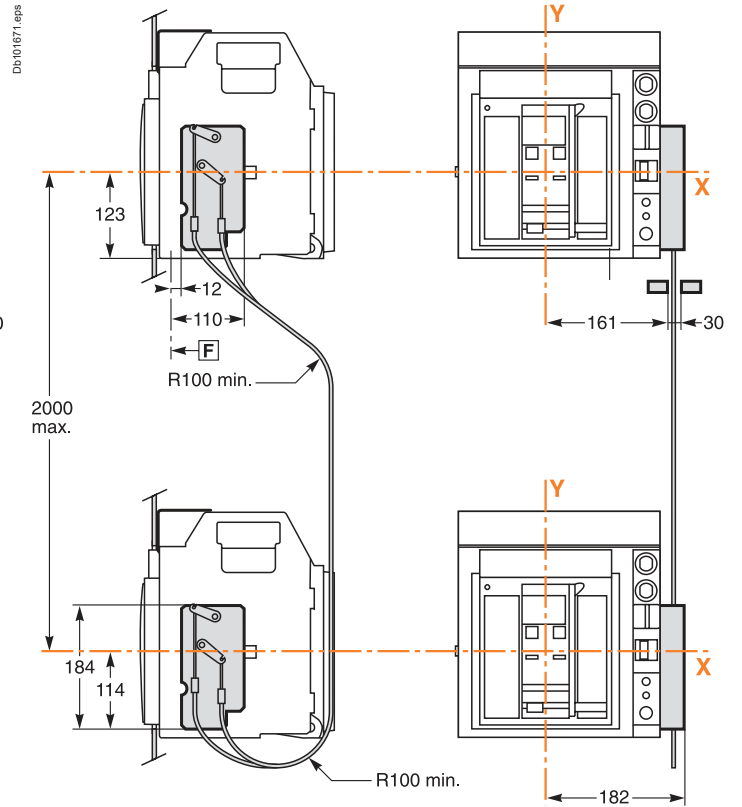

Two Masterpact NT devices one above the other

Fixed devices

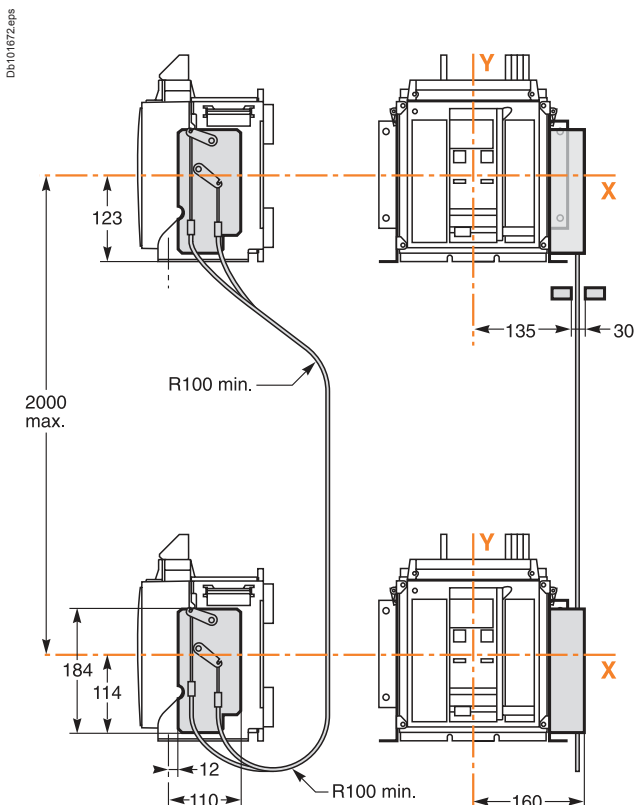

Drawout devices

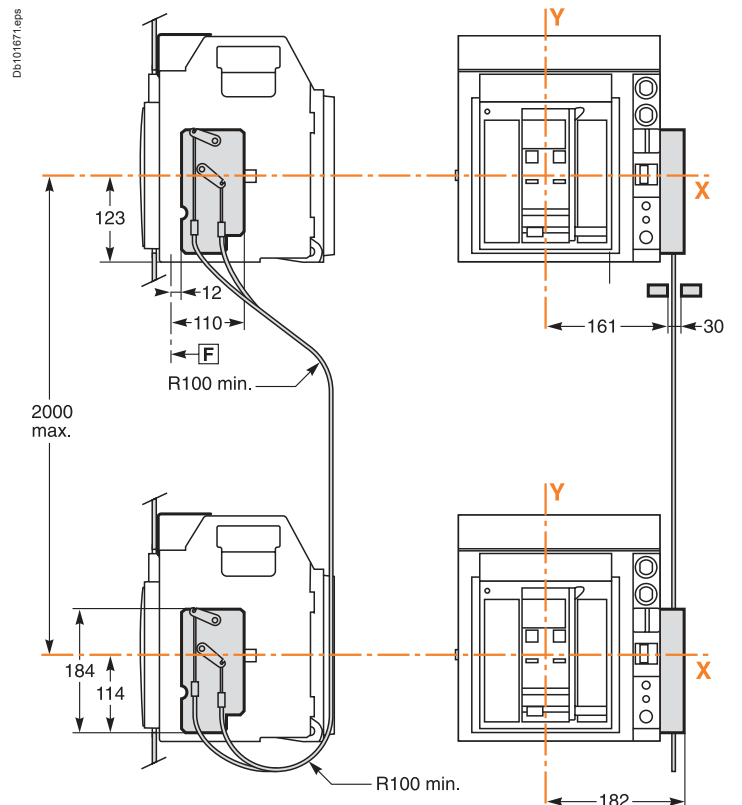

Remote-operated source-changeover systems

Interlocking using cables

Two Masterpact NW devices one above the other

Fixed devices

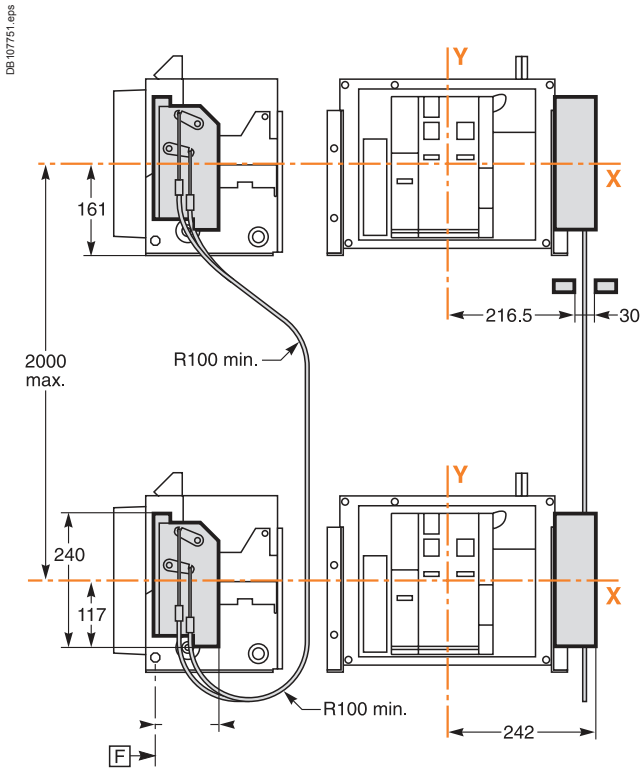

Drawout devices

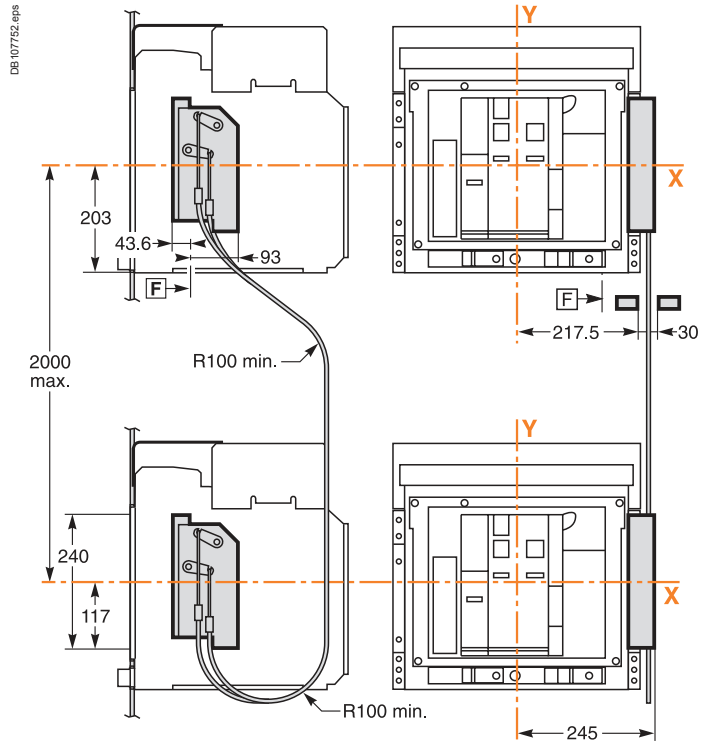

Two Masterpact NT and NW devices one above the other

Fixed devices

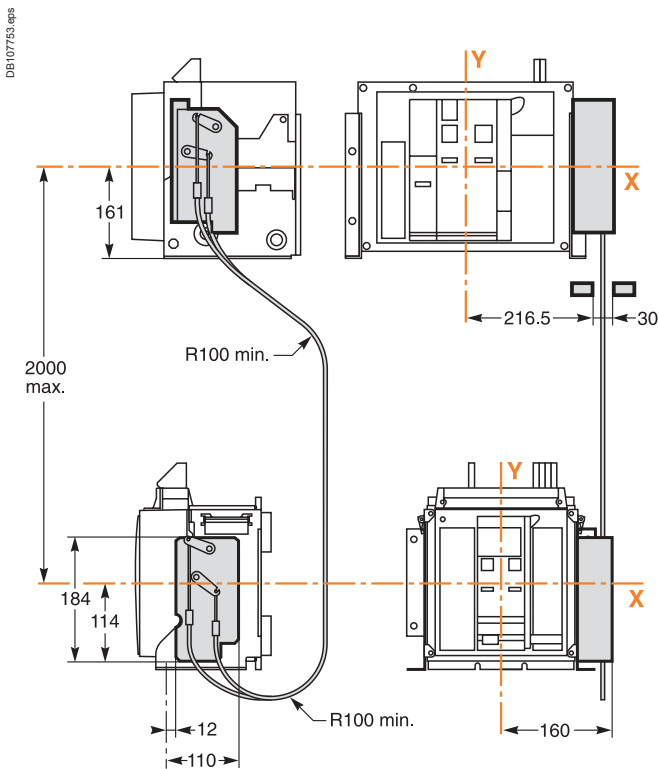

Drawout devices

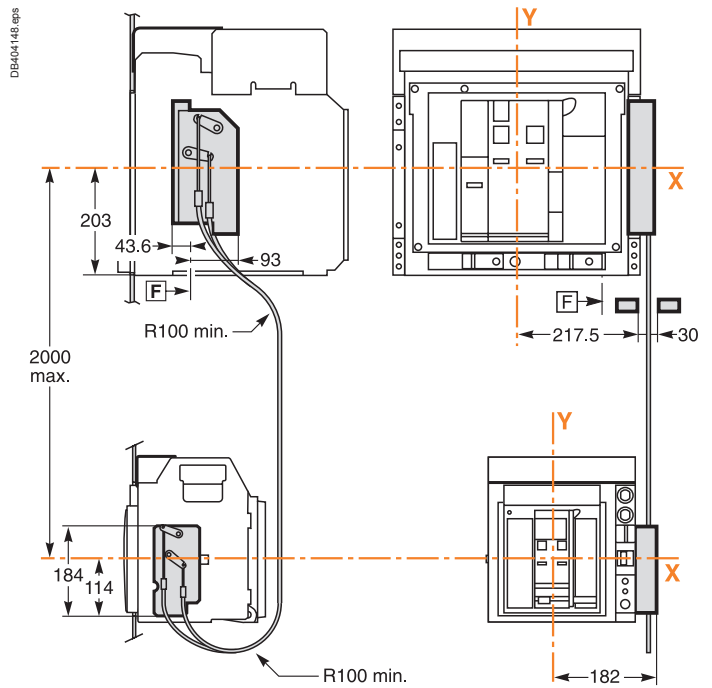

Remote-operated source-changeover systems

Interlocking using cables

Three Masterpact NW devices one above the other

Fixed devices

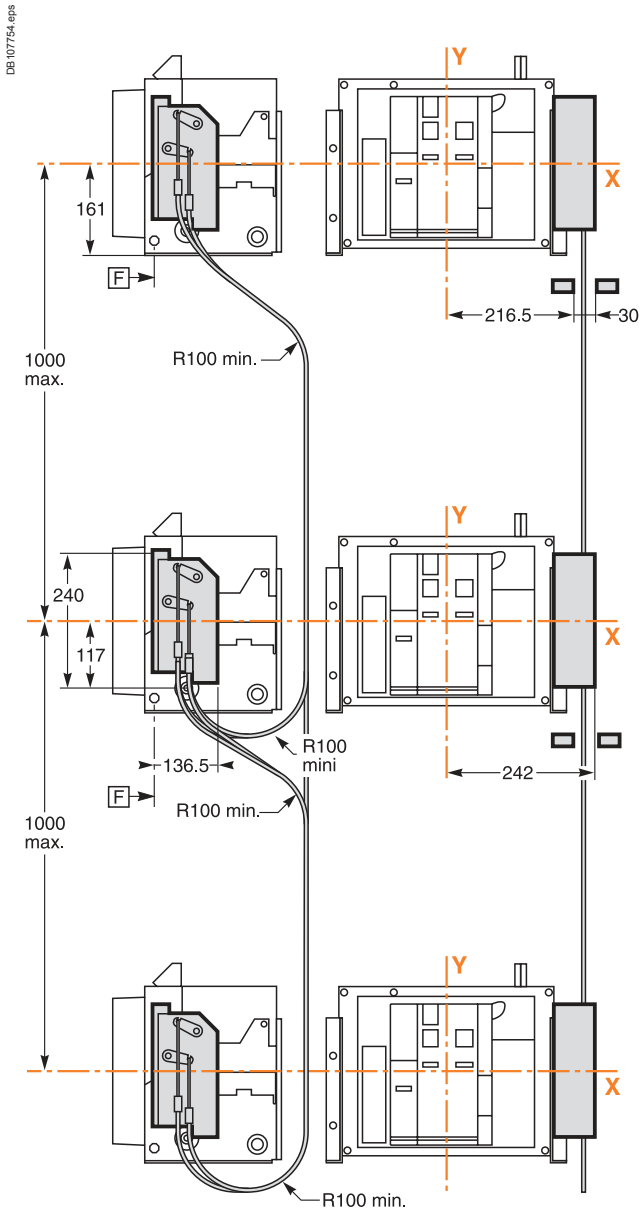

Drawout devices

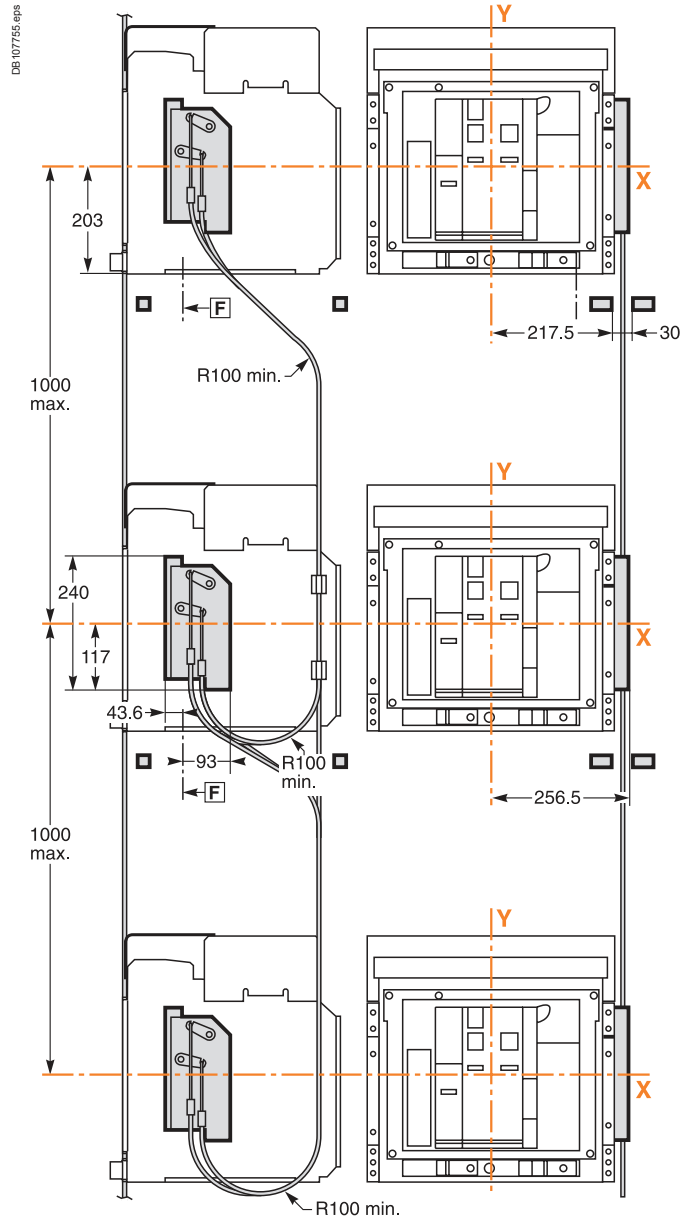

Remote-operated source-changeover systems

IVE unit, BA and UA automatic controllers

IVE unit

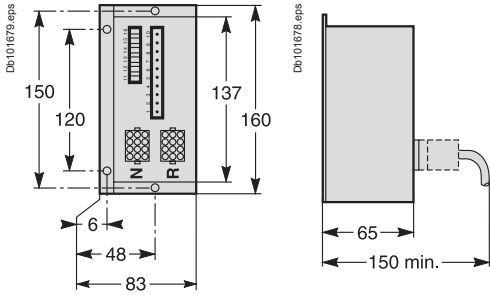

ACP control plate and BA/UA controllers

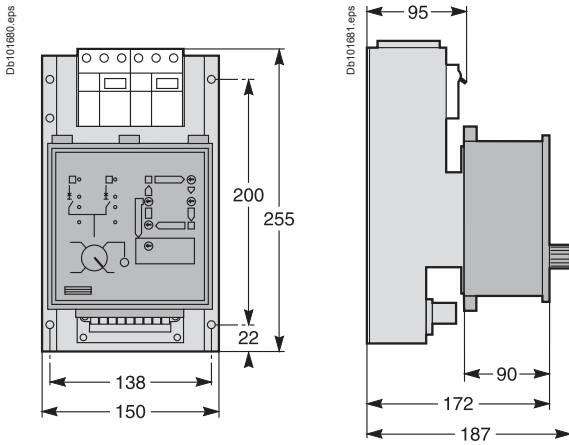

Door cutout for BA/UA controllers

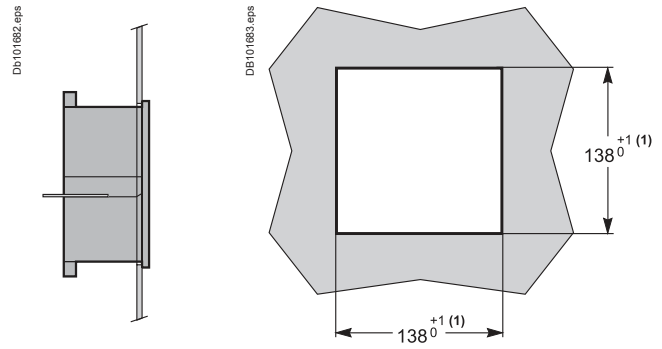

(1) Cutout according DIN 43700 standard.

| | |
|---|------|
| <i>Presentation</i> | 2 |
| <i>Functions and characteristics</i> | A-1 |
| <i>Dimensions</i> | B-1 |
| Remote-operated source-changeover systems | |
| 2 Compact NSX100/630 devices | C-2 |
| 2 Compact NSX100/630, NS630b/1600 or Masterpact NT/NW devices | C-5 |
| Source-changeover systems with automatic controllers | |
| 2 Compact NSX100/630, NS630b/1600 or Masterpact NT/NW devices | C-6 |
| Controller settings | C-7 |
| 2 Compact NSX100/630, NS630b/1600 or Masterpact NT/NW devices | C-8 |
| Remote-operated source-changeover systems | |
| 2 Compact NS630b/1600 devices | C-9 |
| 2 Masterpact NT or NW devices | C-12 |
| 3 Masterpact NW devices | C-17 |
| Source-changeover systems with automatic controllers | |
| 2 Masterpact NT or NW devices | C-26 |
| <i>Catalogue numbers and order forms</i> | D-1 |

Remote-operated source-changeover systems

2 Compact NSX100/630 devices

Diagram no. 51201177

Source-changeover system without automatic-control system

Without auxiliaries for emergency off

Dsb01605.eps

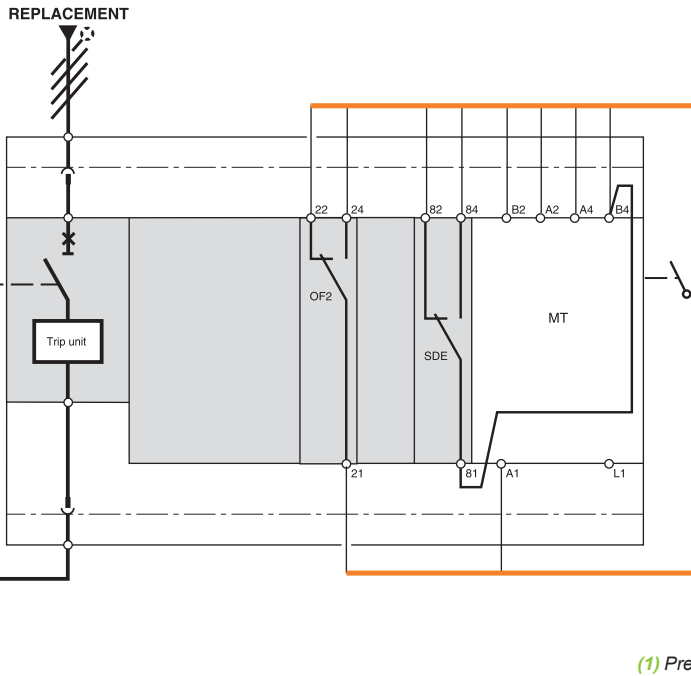
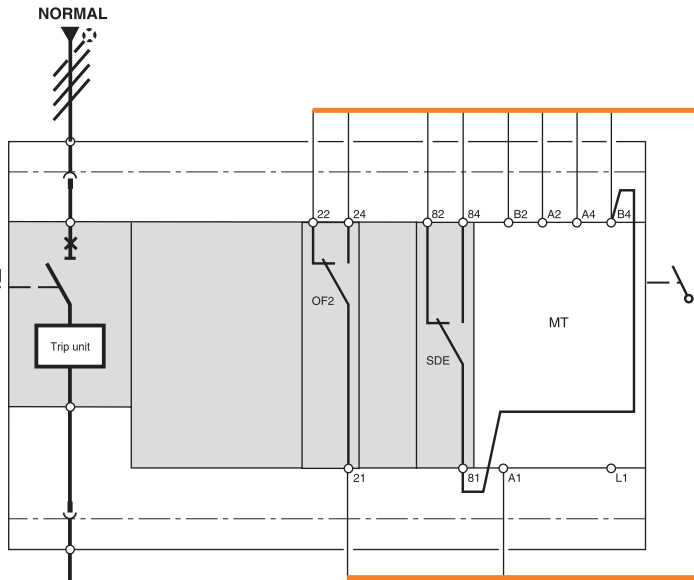

Local reset

Dsb01659.eps

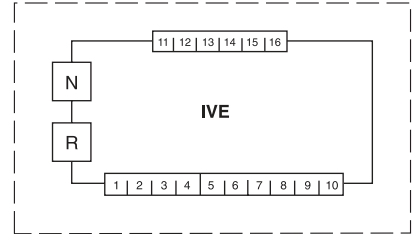

Voluntary remote reset

Dsb01660.eps

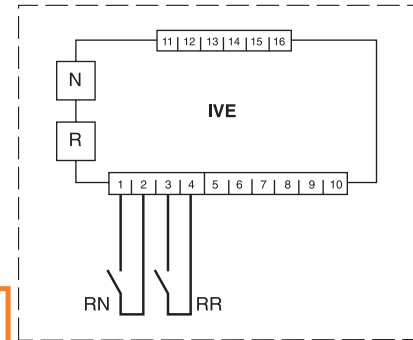

Automatic reset

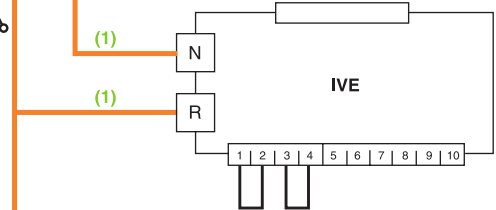

(1) Prefabricated wiring: cannot be modified.

Legends

- QN** "Normal" source Compact NSX equipped with motor mechanism
- QR** "Replacement" source Compact NSX equipped with motor mechanism
- SDE** "fault-trip" indication contact
- IVE** electrical interlocking and terminal block unit
- MT** motor mechanism
- OF2** breaker ON/OFF indication contact
- RN** reset order for breaker QN
- RR** reset order for breaker QR

States permitted by mechanical interlocking system

| Normal | Replacement |
|--------|-------------|
| 0 | 0 |
| 1 | 0 |
| 0 | 1 |

Note: diagram shown with circuits de-energised, circuit breakers open and relays in normal position.

Remote-operated source-changeover systems

2 Compact NSX100/630 devices

Diagram no. 51201178

Source-changeover system without automatic-control system

With emergency off by MN release and automatic reset

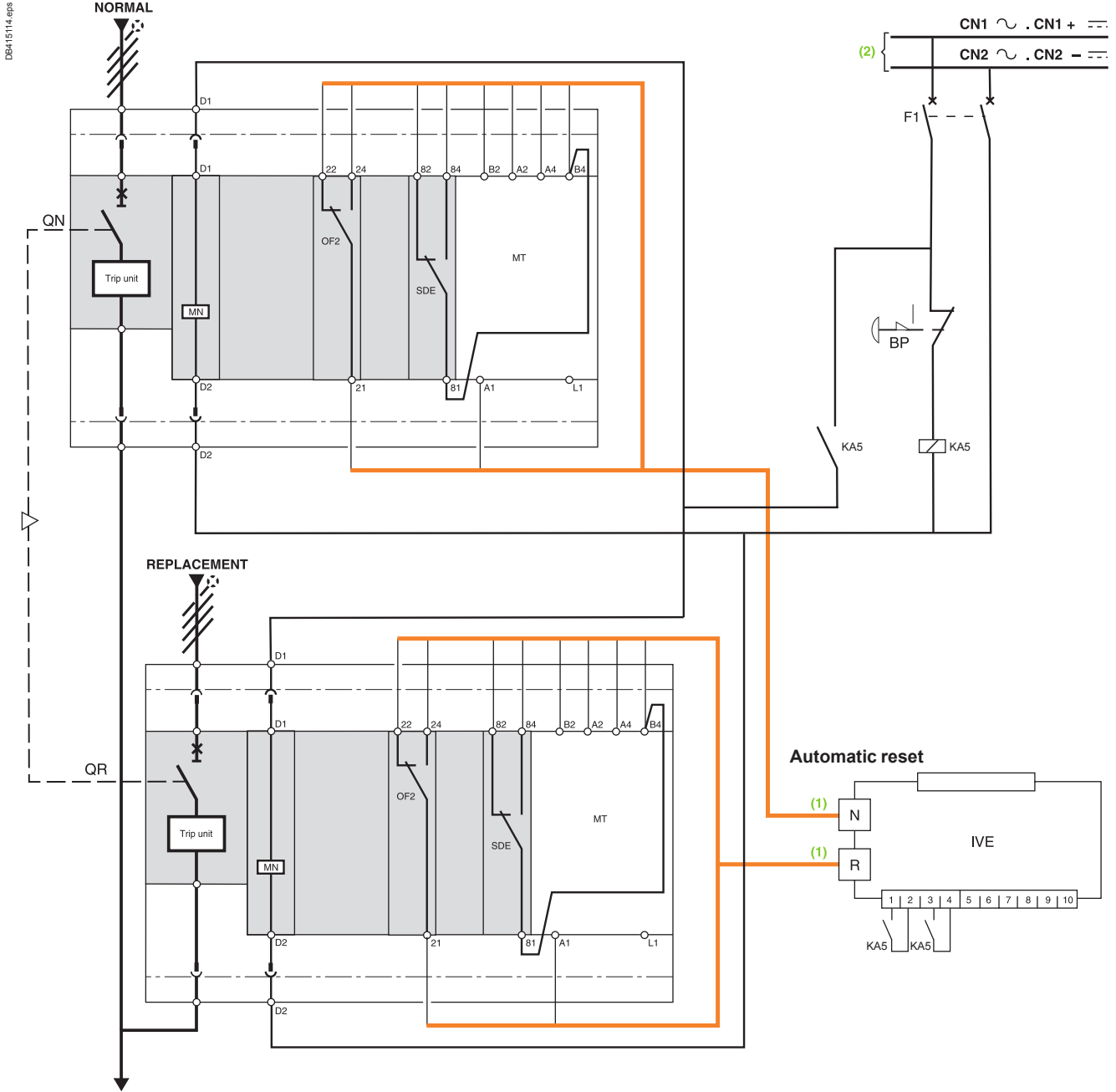

(1) Prefabricated wiring supplied.
 (2) Independent auxiliary source.

Legends

- QN** "Normal" source Compact NSX equipped with motormechanism
- QR** "Replacement" source Compact NSX equipped with motor mechanism
- MN** undervoltage release
- OF2** breaker ON/OFF indication contact
- SDE** "fault-trip" indication contact
- MT** motor mechanism
- IVE** electrical interlocking and terminal block unit
- BP** emergency off button with latching
- KA5** auxiliary relay
- F1** auxiliary power supply circuit breaker

States permitted by mechanical interlocking system

| Normal | Replacement |
|--------|-------------|
| 0 | 0 |
| 1 | 0 |
| 0 | 1 |

Note: after a fault trip, the breaker must be reset manually by pressing its reset button.
 Diagram shown with circuits de-energised, circuit breakers open and relays in normal position.

Remote-operated source-changeover systems

2 Compact NSX100/630 devices

Diagram no. 51201179

Source-changeover system without automatic-control system

With emergency off by MX release and automatic reset

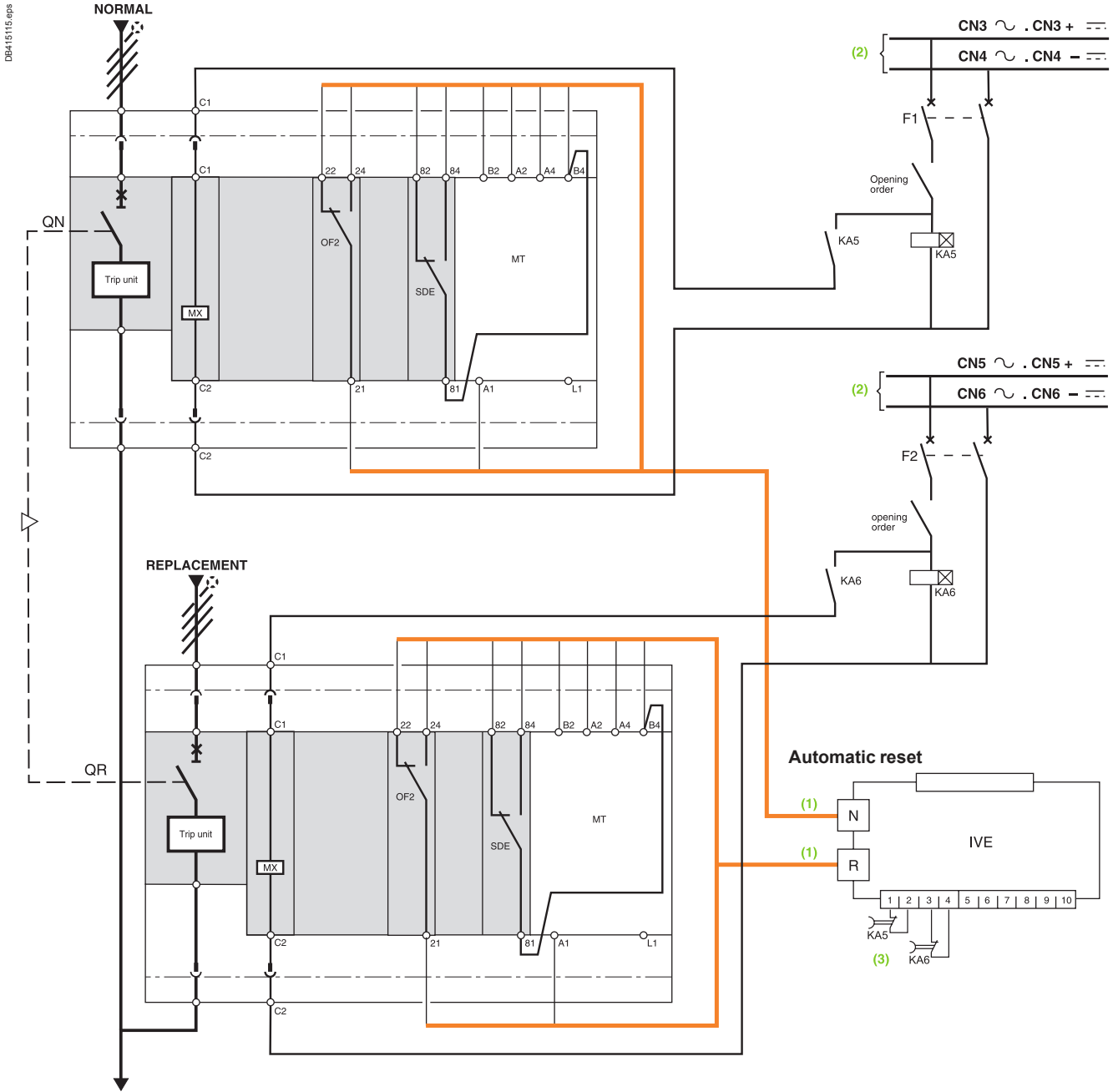

- (1) Prefabricated wiring supplied
- (2) This source can be:
 - the source present in the case of voltage monitoring
 - an independent source.
 In this case, the MX release must be protected.
- (3) The reset orders must be delayed by 0.3 seconds.

Legends

- QN "Normal" source Compact NSX equipped with motor mechanism
- QR "Replacement" source Compact NSX equipped with motor mechanism
- SDE "fault-trip" indication contact
- OF2 breaker ON/OFF indication contact
- MX shunt release
- MT motor mechanism
- IVE electrical interlocking and terminal block unit
- KA5 time-delayed auxiliary relays
- KA6 time-delayed auxiliary relays
- F1 auxiliary power supply circuit breaker
- F2 auxiliary power supply circuit breaker

States permitted by mechanical interlocking system

| Normal | Replacement |
|--------|-------------|
| 0 | 0 |
| 1 | 0 |
| 0 | 1 |

Note: after a fault trip, the breaker must be reset manually by pressing its reset button. Diagram shown with circuits de-energised, circuit breakers open and relays in normal position.

Remote-operated source-changeover systems

2 Compact NSX100/630, NS630b/1600 or Masterpact NT/NW devices

Electrical interlocking by the IVE unit

Independent order to Normal/Replacement source

Simultaneous order to Normal/Replacement source

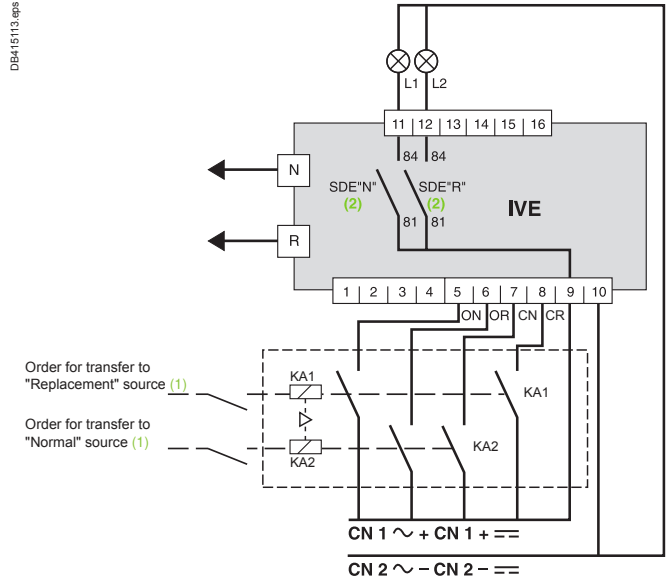
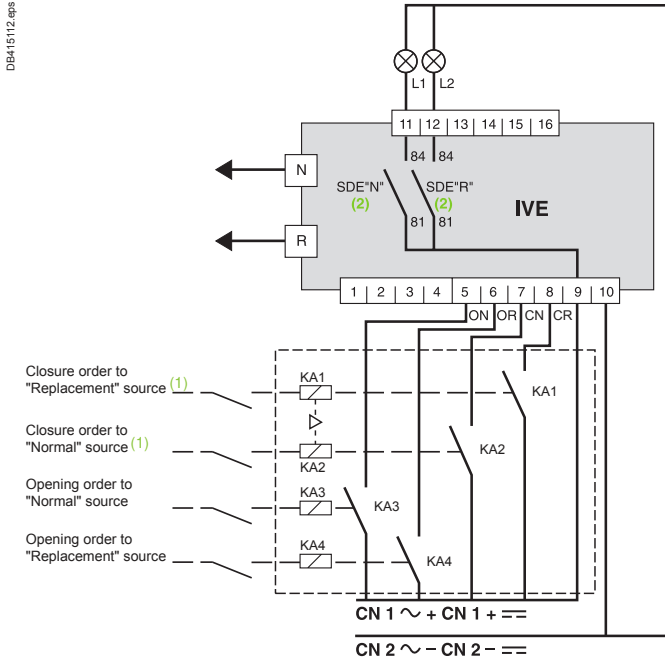

Controlling each circuit breaker independently.

Control of two circuit breakers by "common" transfer order.

(1) See section "IMPORTANT" here after.

(2) Operating diagram: the SDE "fault-trip" signals are transmitted to the IVE unit. The SDE auxiliary contacts are mounted in the circuit breakers.

IMPORTANT

The relays controlling the closing order to the "Normal" and "Replacement" circuit breakers must be mechanically and/or electrically interlocked to prevent them from giving simultaneous closing commands.

It is recommended to use Tesys K relays from Schneider Electric reference LC2-K06010●●. These relays are mechanically and electrically interlocked.

Legends

- ON "Normal" source opening order
- OR "Replacement" source opening order
- CN "Normal" source closing order
- CR "Replacement" source closing order
- KA1 auxiliary relay
- KA2 auxiliary relay
- KA3 auxiliary relay
- KA4 auxiliary relay
- L1 "Normal" source "fault-trip" signal
- L2 "Replacement" source "fault-trip" signal
- N "Normal" source auxiliary wiring connector
- R "Replacement" source auxiliary wiring connector

Note: diagram shown with circuits de-energised, circuit breakers open and relays in normal position.

Source-changeover systems with automatic controllers

2 Compact NSX100/630, NS630b/1600 or Masterpact NT/NW devices

Source-changeover system with UA controller

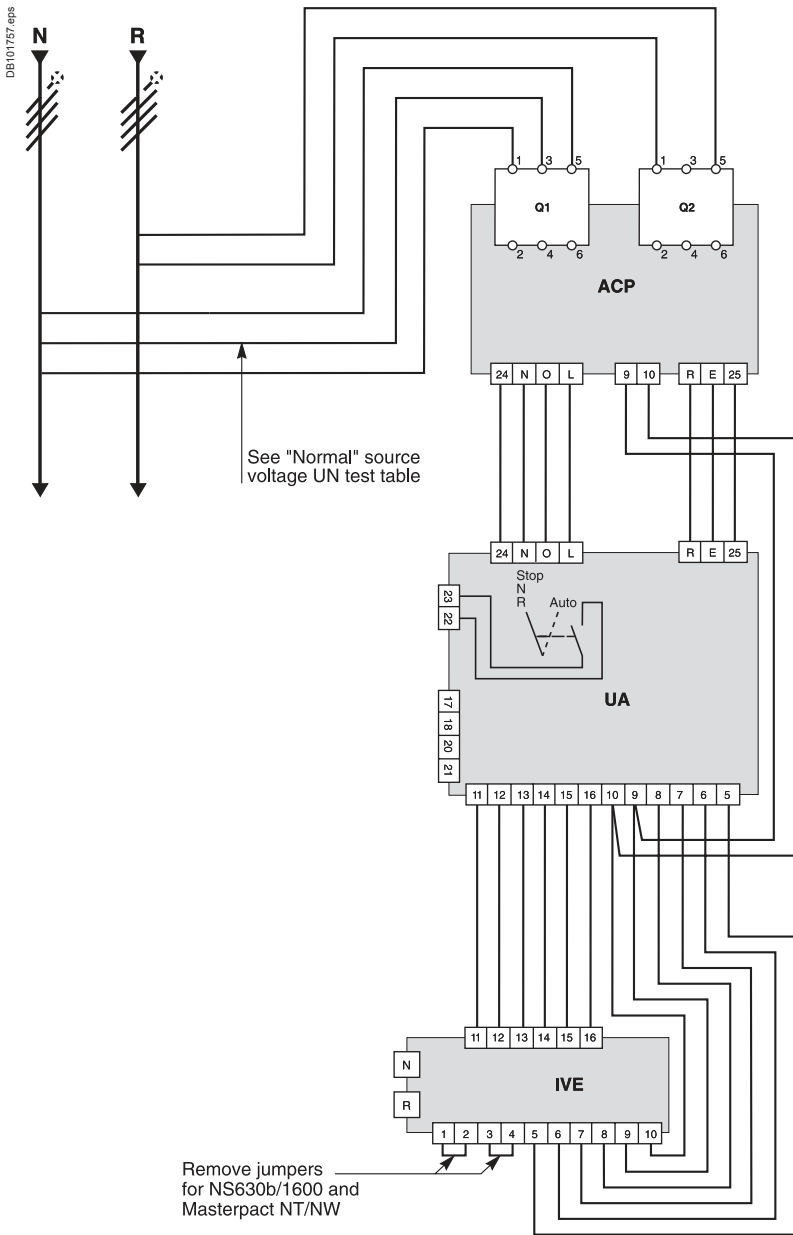

Load shedding and genset management

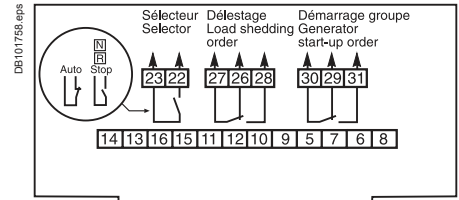

Transfer conditions

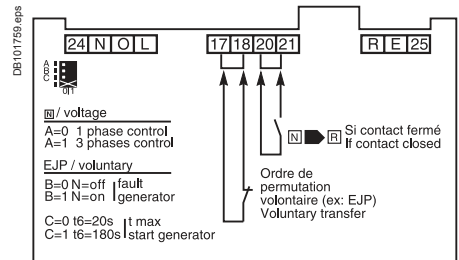

Terminals 20 and 21:
additional control contact (not part of controller).

Tests on "Normal" and "Replacement" source voltages

"Normal" source voltage UN test

| Ref. UA UA150 | 29472 29474 | 29472 29474 | 29473 29475 |
|------------------|--------------------------------|--------------------------------|---|
| Supply voltage | N / φ 220/240VAC 50/60Hz | φ / φ 220/240VAC 50/60Hz | φ / φ 380/415VAC 50/60Hz 440V - 60Hz |
| Switch position | | | |
| A = 0 | | | |
| A = 1 | | | |

"Replacement" source voltage UR test

The single-phase check for UR is implemented across terminals 1 and 5 of circuit breaker Q2.

Legends

- Q1** circuit breaker supplying and protecting the automatic-control circuits for the "Normal" source
- Q2** circuit breaker supplying and protecting the automatic-control circuits for the "Replacement" source
- ACP** control plate
- UA** automatic controller
- IVE** electrical interlocking and terminal block unit

Note: diagram shown with circuits de-energised, circuit breakers open and relays in normal position.

Source changeover system with UA controller

Controller settings

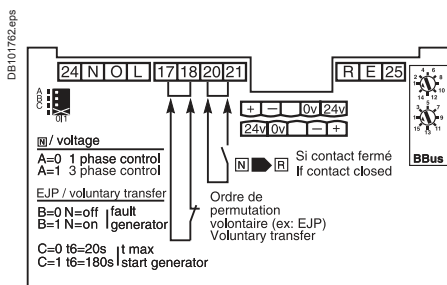

Using communication functions

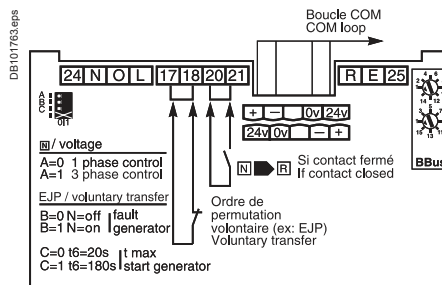

Tests on “Normal” source voltage

- A = 0 single-phase test,
- A = 1 three-phase test.

Voluntary transfert (e.g. for energy management)

- action in the event of genset failure
- B = 0 circuit breaker N opens,
- B = 1 circuit breaker N remains closed.
- maximum permissible genset startup time (T6)
- C = 0 T = 120 s,
- C = 1 T = 180 s.

After this time has elapsed, the genset is considered to have failed.

The address of the UA 150 controller is set using the two BBus dials.

Source-changeover systems with automatic controllers

2 Compact NSX100/630, NS630b/1600 or Masterpact NT/NW devices

Source-changeover system with BA controller

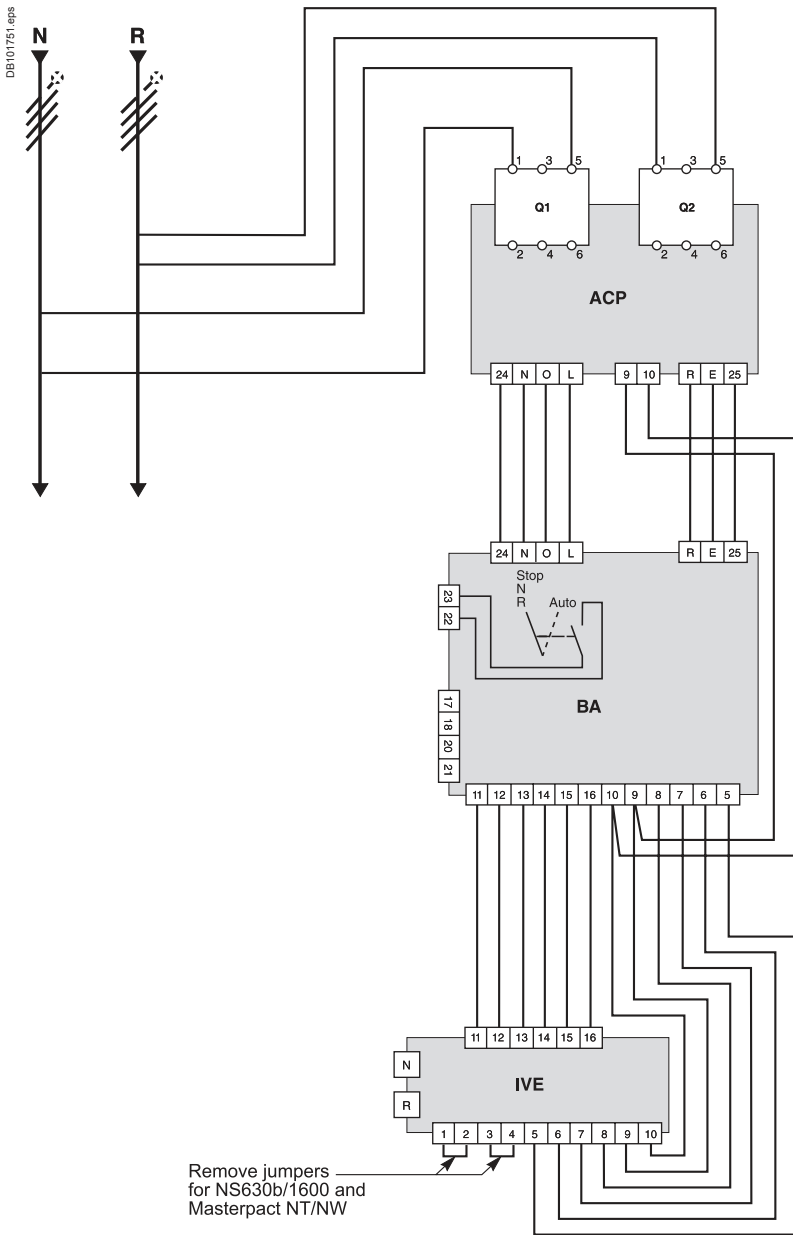

Coupling

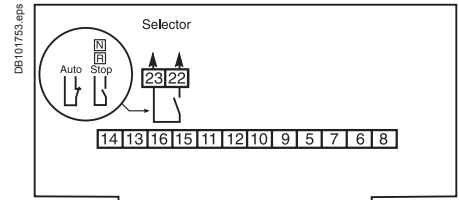

Transfer conditions

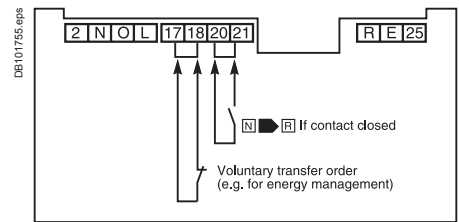

Terminals 20 and 21:

additional control contact (not part of controller).

Tests on "Normal" and "Replacement" source voltages

The single-phase check for UN and UR is implemented across terminals 1 and 5 of circuit breakers Q1 and Q2.

Legends

- Q1** circuit breaker supplying and protecting the automatic-control circuits for the "Normal" source
- Q2** circuit breaker supplying and protecting the automatic-control circuits for the "Replacement" source
- ACP** control plate
- BA** automatic controller
- IVE** electrical interlocking and terminal block unit

Note: diagram shown with circuits de-energised, circuit breakers open and relays in normal position.

Electrical interlocking by IVE unit

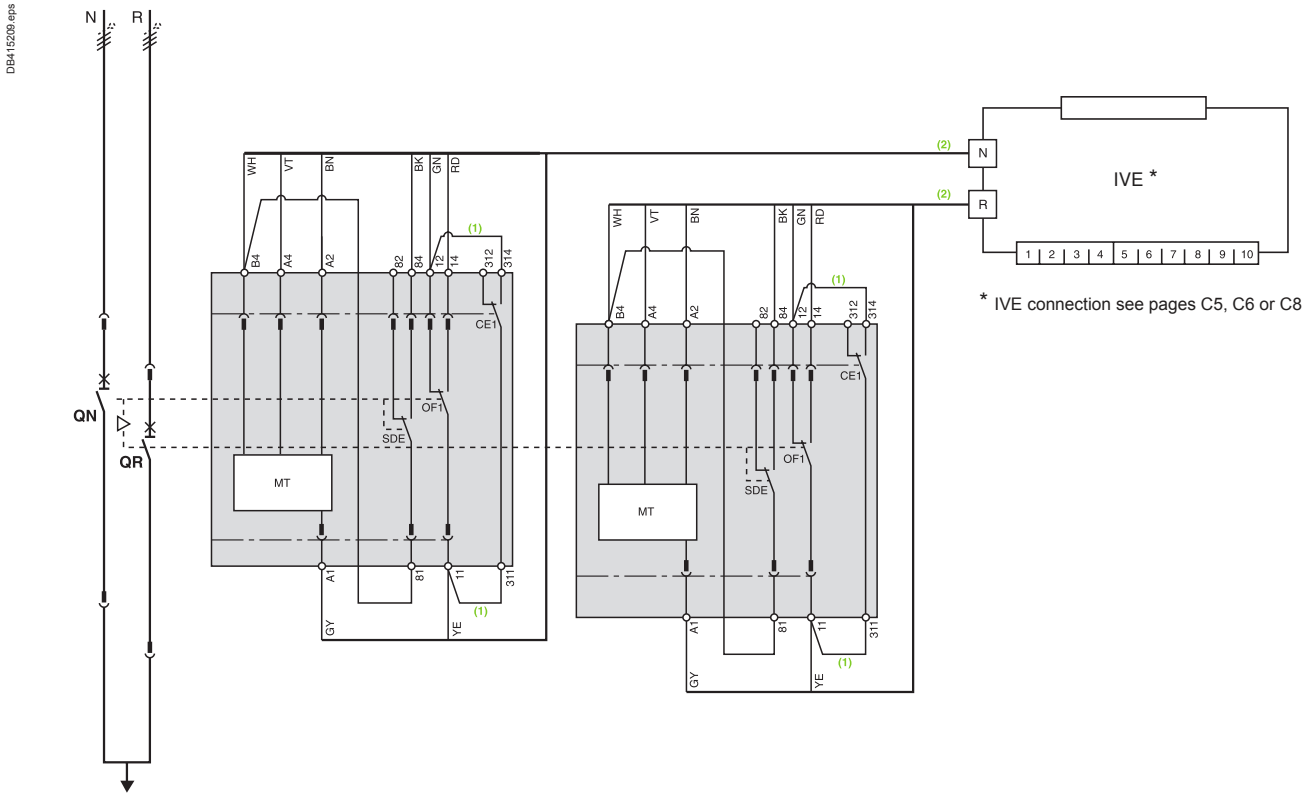

ATTENTION

The diagram shows the electrical wiring for circuit breakers. When wiring the SDE with **switch-disconnectors**, connect wire BK to terminal 82.

- (1) Not to be wired on fixed version.
- (2) Prefabricated wiring supplied.

Legends

- QN** "Normal" source Compact NS630b to 1600
- QR** "Replacement" source Compact NS630b to 1600
- OF...** breaker ON/OFF indication contact
- SDE** "fault-trip" indication contact
- CE1** "connected-position" indication contact (carriage switch)
- F1** auxiliary power supply circuit breaker
- IVE** electrical interlocking and terminal block unit
- ON** "Normal" source opening order
- OR** "Replacement" source opening order
- CN** "Normal" source closing order (0.25 second delay)
- CR** "Replacement" source closing order (0.25 second delay)
- MT** Motor Mechanism

Wiring colour codes

| | | | | | | | |
|-----|-------|-------|--------|--------|------|-------|-------|
| RD | GN | BK | VT | YE | GY | WH | BN |
| red | green | black | violet | yellow | grey | white | brown |

States permitted by mechanical interlocking system

| Normal | Replacement |
|--------|-------------|
| 0 | 0 |
| 1 | 0 |
| 0 | 1 |

Note: after a fault trip, the breaker must be reset manually by pressing its reset button. Diagram shown with circuit breakers in connected position, open, charged, and ready to close. Auxiliary power supply = supply voltage of auxiliary relays (KA...) = supply voltage of electrical auxiliaries (electrical operation, MT...).

Remote-operated source-changeover systems

2 Compact NS630b/1600 devices

Diagram no. 51201184

Electrical interlocking by IVE unit with emergency off by shunt release

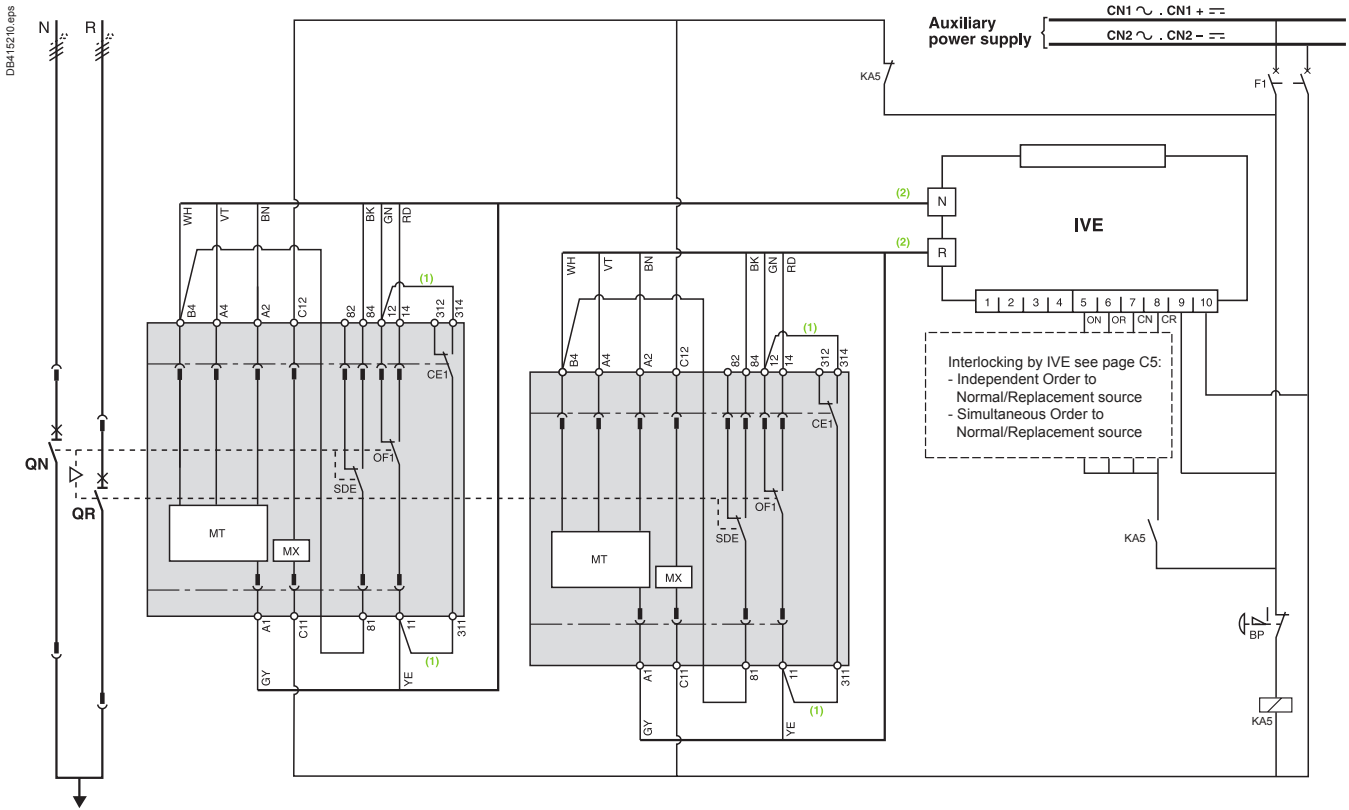

ATTENTION

The diagram shows the electrical wiring for circuit breakers. When wiring the SDE with switch-disconnectors, connect wire BK to terminal 82.

(1) Not to be wired on fixed version.
 (2) Prefabricated wiring supplied.

Legends

- QN "Normal" source Compact NS630b to 1600
- QR "Replacement" source Compact NS630b to 1600
- OF... breaker ON/OFF indication contact
- SDE "fault-trip" indication contact
- CE1 "connected-position" indication contact (carriage switch)
- F1 auxiliary power supply circuit breaker
- IVE electrical interlocking and terminal block unit
- MX shunt release
- BP emergency off button with latching
- KA5 auxiliary relay
- ON "Normal" source opening order
- OR "Replacement" source opening order
- CN "Normal" source closing order (0.25 second delay)
- CR "Replacement" source closing order (0.25 second delay)
- MT Motor Mechanism

Wiring colour codes

| | | | | | | | |
|-----|-------|-------|--------|--------|------|-------|-------|
| RD | GN | BK | VT | YE | GY | WH | BN |
| red | green | black | violet | yellow | grey | white | brown |

States permitted by mechanical interlocking system

| Normal | Replacement |
|--------|-------------|
| 0 | 0 |
| 1 | 0 |
| 0 | 1 |

Note: after a fault trip, the breaker must be reset manually by pressing its reset button. Diagram shown with circuit breakers in connected position, open, charged, and ready to close. Auxiliary power supply = supply voltage of auxiliary relays (KA...) = supply voltage of electrical auxiliaries (electrical operation, MX, MT...).

Remote-operated source-changeover systems

2 Compact NS630b/1600 devices

Diagram no. 51201185

Electrical interlocking by IVE unit with emergency off by undervoltage release

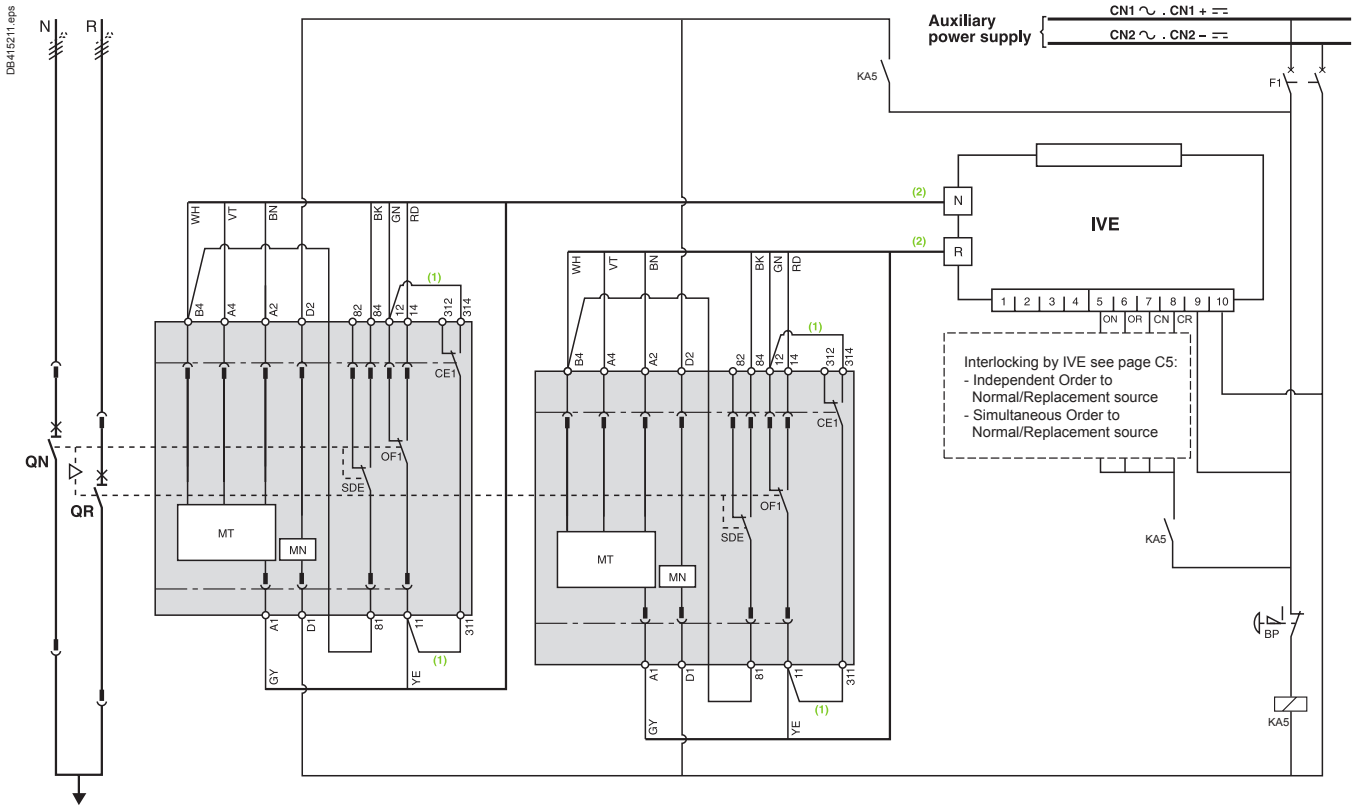

ATTENTION

The diagram shows the electrical wiring for circuit breakers. When wiring the SDE with switch-disconnectors, connect wire BK to terminal 82.

- (1) Not to be wired on fixed version.
- (2) Prefabricated wiring supplied.

Legends

- QN "Normal" source Compact NS630b to 1600
- QR "Replacement" source Compact NS630b to 1600
- OF... breaker ON/OFF indication contact
- SDE "fault-trip" indication contact
- CE1 "connected-position" indication contact (carriage switch)
- F1 auxiliary power supply circuit breaker
- IVE electrical interlocking and terminal block unit
- MN undervoltage release
- BP emergency off button with latching
- KA5 auxiliary relay
- ON "Normal" source opening order
- OR "Replacement" source opening order
- CN "Normal" source closing order (0.25 second delay)
- CR "Replacement" source closing order (0.25 second delay)
- MT Motor Mechanism

Wiring colour codes

| | | | | | | | |
|-----|-------|-------|--------|--------|------|-------|-------|
| RD | GN | BK | VT | YE | GY | WH | BN |
| red | green | black | violet | yellow | grey | white | brown |

States permitted by mechanical interlocking system

| Normal | Replacement |
|--------|-------------|
| 0 | 0 |
| 1 | 0 |
| 0 | 1 |

Note: after a fault trip, the breaker must be reset manually by pressing its reset button. Diagram shown with circuit breakers in connected position, open, charged, and ready to close. Auxiliary power supply = supply voltage of auxiliary relays (KA...) = supply voltage of electrical auxiliaries (electrical operation, MN, MT...).

Remote-operated source-changeover systems

2 Masterpact NT or NW devices

Diagram no. 51201142

Electrical interlocking by IVE unit with lockout after a fault

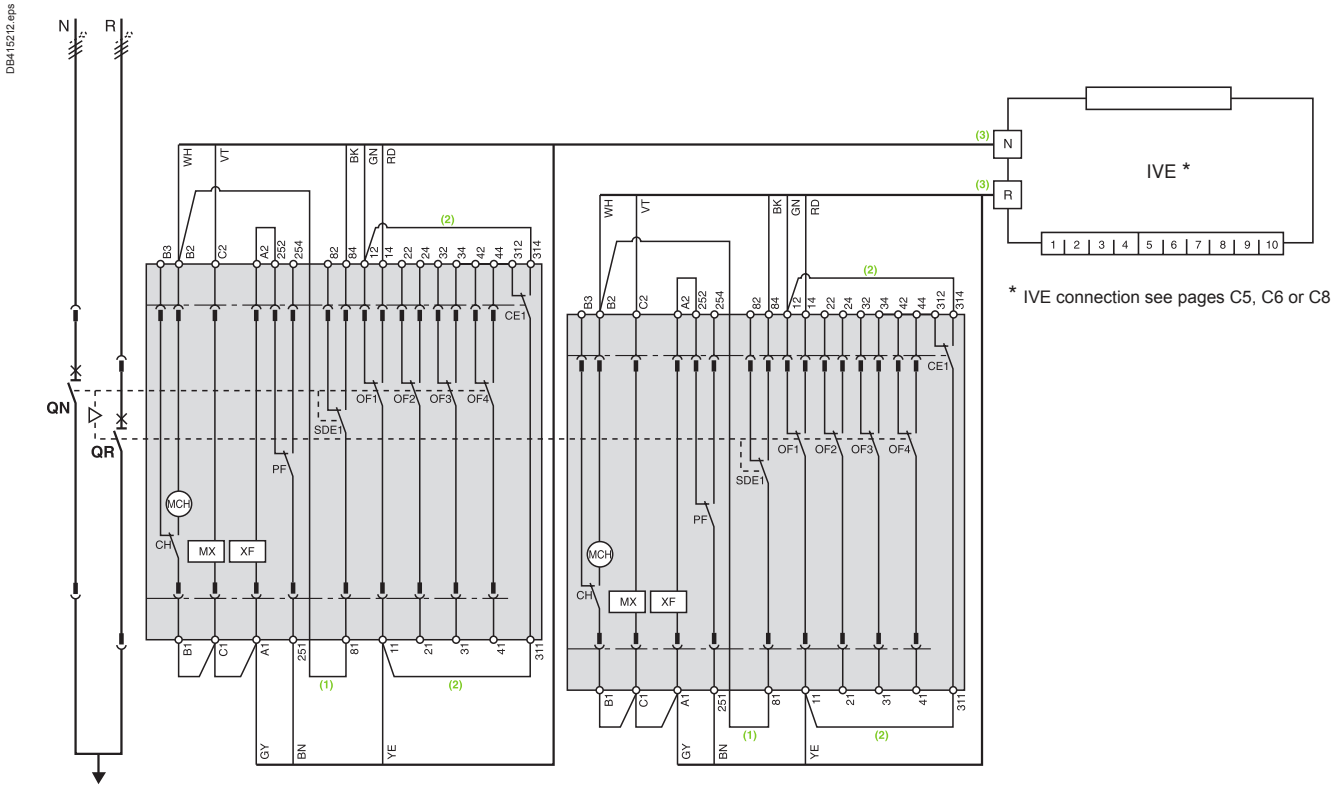

* IVE connection see pages C5, C6 or C8

ATTENTION

The diagram shows the electrical wiring for circuit breakers. When wiring the SDE with **switch-disconnectors**, connect wire **BK** to terminal **82**.

- (1) Not to be wired for the "without lockout after a fault" solution.
- (2) Not to be wired on fixed version.
- (3) Prefabricated wiring supplied.

Legends

- QN "Normal" source Masterpact NT or NW
- QR "Replacement" source Masterpact NT or NW
- MCH spring-charging motor
- MX standard opening voltage release
- XF standard closing voltage release
- OF... breaker ON/OFF indication contact
- SDE1 "fault-trip" indication contact
- PF "ready-to-close" contact
- CE1 "connected-position" indication contact (carriage switch)
- CH "springs charged" indication contact
- IVE electrical interlocking and terminal block unit
- F1 auxiliary power supply circuit breaker
- ON "Normal" source opening order
- OR "Replacement" source opening order
- CN "Normal" source closing order (0.25 second delay)
- CR "Replacement" source closing order (0.25 second delay)

Wiring colour codes

| | | | | | | | |
|-----|-------|-------|--------|--------|------|-------|-------|
| RD | GN | BK | VT | YE | GY | WH | BN |
| red | green | black | violet | yellow | grey | white | brown |

States permitted by mechanical interlocking system

| Normal | Replacement |
|--------|-------------|
| 0 | 0 |
| 1 | 0 |
| 0 | 1 |

Note: diagram shown with circuit breakers in connected position, open, charged, and ready to close. Auxiliary power supply = supply voltage of auxiliary relays (KA...) = supply voltage of electrical auxiliaries (electrical operation, MCH, MX, XF...).

Remote-operated source-changeover systems

2 Masterpact NT or NW devices

Diagram no. 51201143

Electrical interlocking by IVE unit with lockout after a fault and emergency off by shunt release

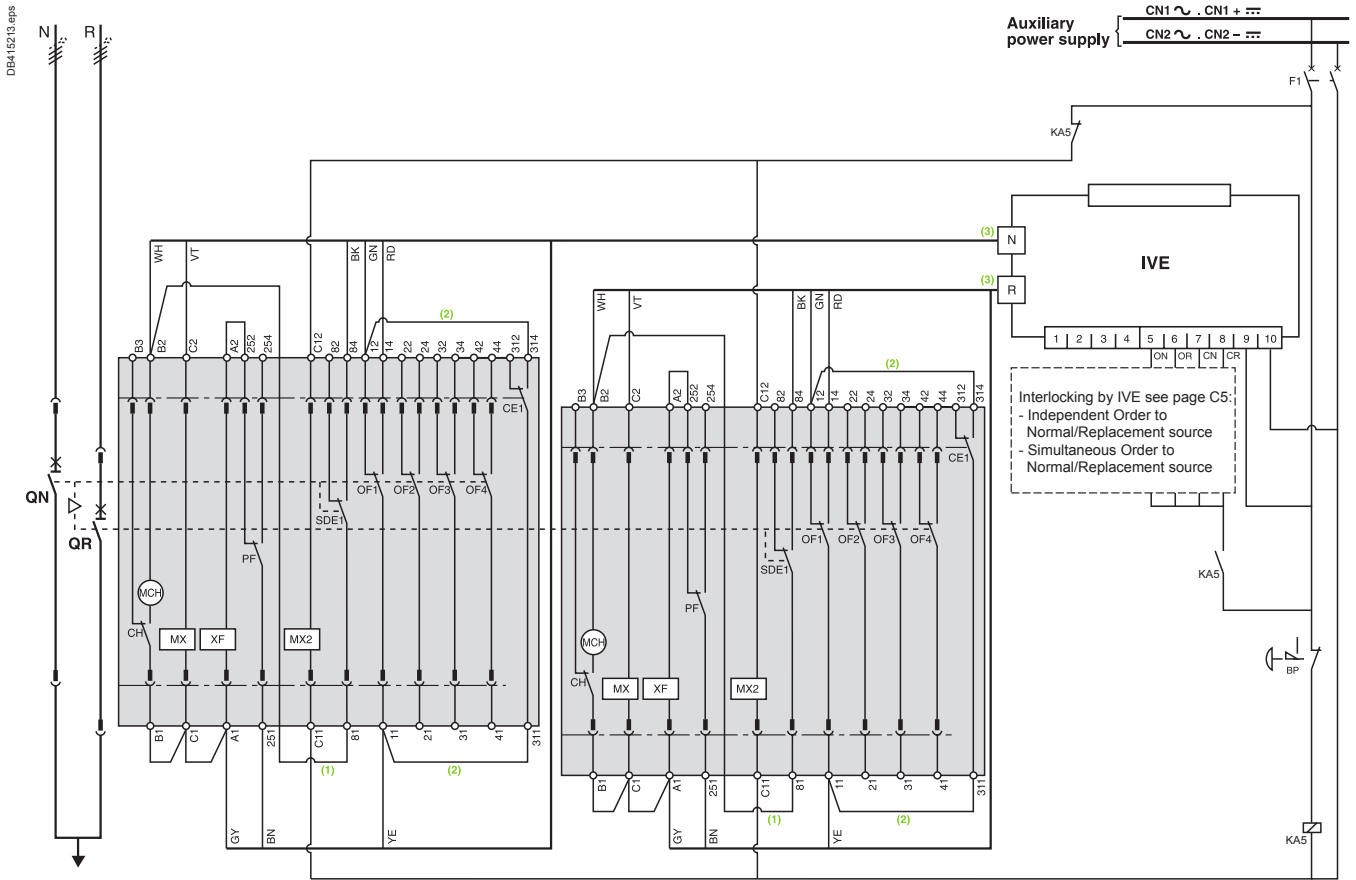

ATTENTION

The diagram shows the electrical wiring for circuit breakers. When wiring the SDE with switch-disconnectors, connect wire BK to terminal 82.

- (1) Not to be wired for the "without lockout after a fault" solution.
- (2) Not to be wired on fixed version.
- (3) Prefabricated wiring supplied.

Legends

- QN "Normal" source Masterpact NT or NW
- QR "Replacement" source Masterpact NT or NW
- MCH spring-charging motor
- MX standard opening voltage release
- XF standard closing voltage release
- OF... breaker ON/OFF indication contact
- SDE1 "fault-trip" indication contact
- PF "ready-to-close" contact
- CE1 "connected-position" indication contact (carriage switch)
- CH "springs charged" indication contact
- IVE electrical interlocking and terminal block unit
- KA5 auxiliary relay
- F1 auxiliary power supply circuit breaker
- BP emergency off button with latching
- ON "Normal" source opening order
- OR "Replacement" source opening order
- CN "Normal" source closing order (0.25 second delay)
- CR "Replacement" source closing order (0.25 second delay)

Wiring colour codes

| | | | | | | | |
|-----|-------|-------|--------|--------|------|-------|-------|
| RD | GN | BK | VT | YE | GY | WH | BN |
| red | green | black | violet | yellow | grey | white | brown |

States permitted by mechanical interlocking system

| Normal | Replacement |
|--------|-------------|
| 0 | 0 |
| 1 | 0 |
| 0 | 1 |

Note: diagram shown with circuit breakers in connected position, open, charged, and ready to close. Auxiliary power supply = supply voltage of auxiliary relays (KA...) = supply voltage of electrical auxiliaries (electrical operation, MCH, MX, XF...).

Remote-operated source-changeover systems

2 Masterpact NT or NW devices

Diagram no. 51201144

Electrical interlocking by IVE unit with lockout after a fault and emergency off by undervoltage release

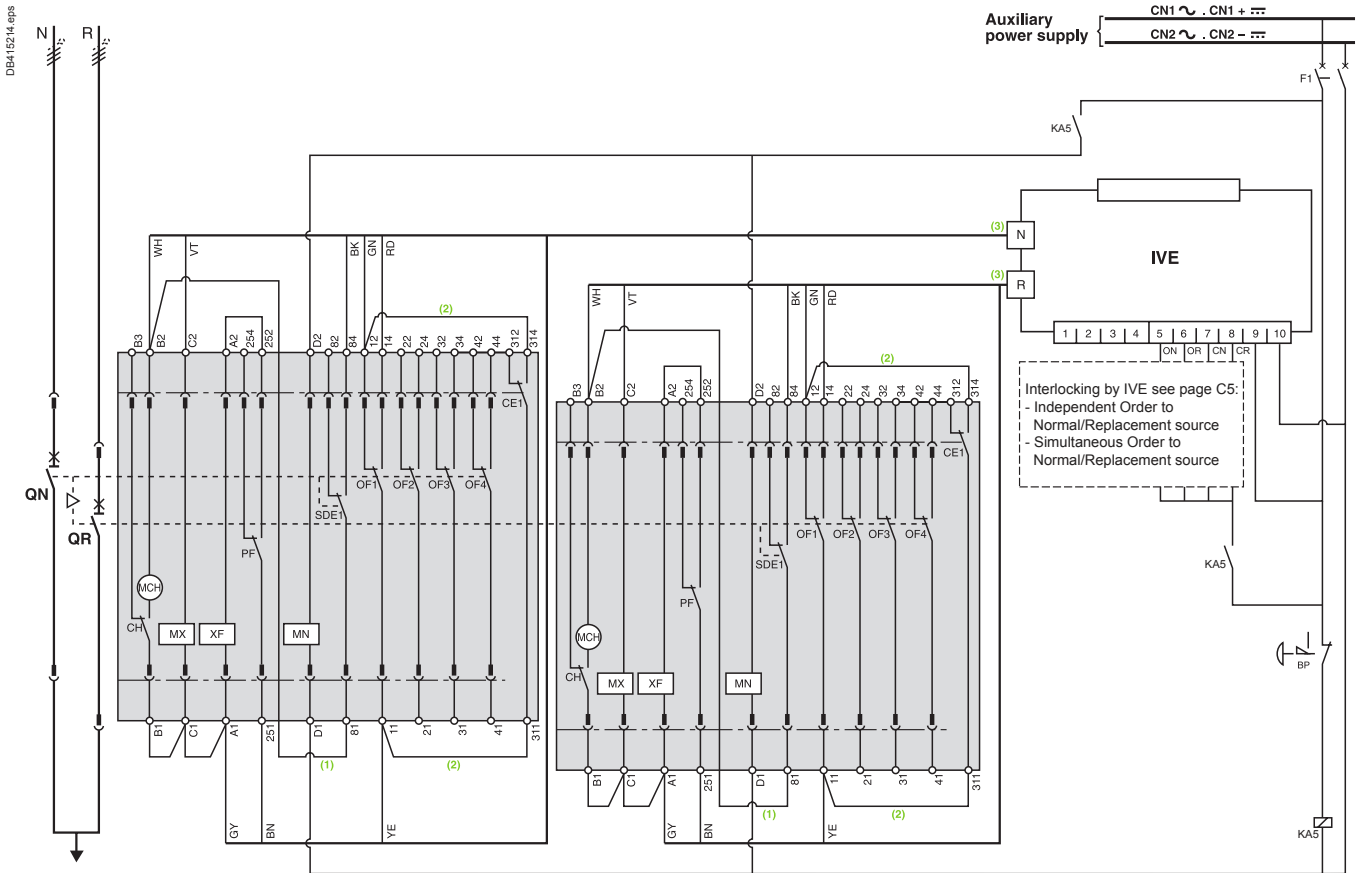

ATTENTION
The diagram shows the electrical wiring for circuit breakers. When wiring the SDE with **switch-disconnectors**, connect wire BK to terminal 82.

- (1) Not to be wired for the "without lockout after a fault" solution.
- (2) Not to be wired on fixed version.
- (3) Prefabricated wiring supplied.

Legends

- QN "Normal" source Masterpact NT or NW
- QR "Replacement" source Masterpact NT or NW
- MCH spring-charging motor
- MX standard opening voltage release
- XF standard closing voltage release
- MN undervoltage release
- OF... breaker ON/OFF indication contact
- SDE1 "fault-trip" indication contact
- PF "ready-to-close" contact
- CE1 "connected-position" indication contact (carriage switch)
- CH "springs charged" indication contact
- IVE electrical interlocking and terminal block unit
- KA5 auxiliary relay
- F1 auxiliary power supply circuit breaker
- BP emergency off button with latching
- ON "Normal" source opening order
- OR "Replacement" source opening order
- CN "Normal" source closing order (0.25 second delay)
- CR "Replacement" source closing order (0.25 second delay)

Wiring colour codes

| | | | | | | | |
|-----|-------|-------|--------|--------|------|-------|-------|
| RD | GN | BK | VT | YE | GY | WH | BN |
| red | green | black | violet | yellow | grey | white | brown |

States permitted by mechanical interlocking system

| Normal | Replacement |
|--------|-------------|
| 0 | 0 |
| 1 | 0 |
| 0 | 1 |

Note: diagram shown with circuit breakers in connected position, open, charged, and ready to close. Auxiliary power supply = supply voltage of auxiliary relays (KA...) = supply voltage of electrical auxiliaries (electrical operation, MCH, MX, MN, XF...).

Remote-operated source-changeover systems

2 Masterpact NT or NW devices

Diagram no. 51 156904

Automatic-control system for permanent replacement source with lockout after a fault (with MN)

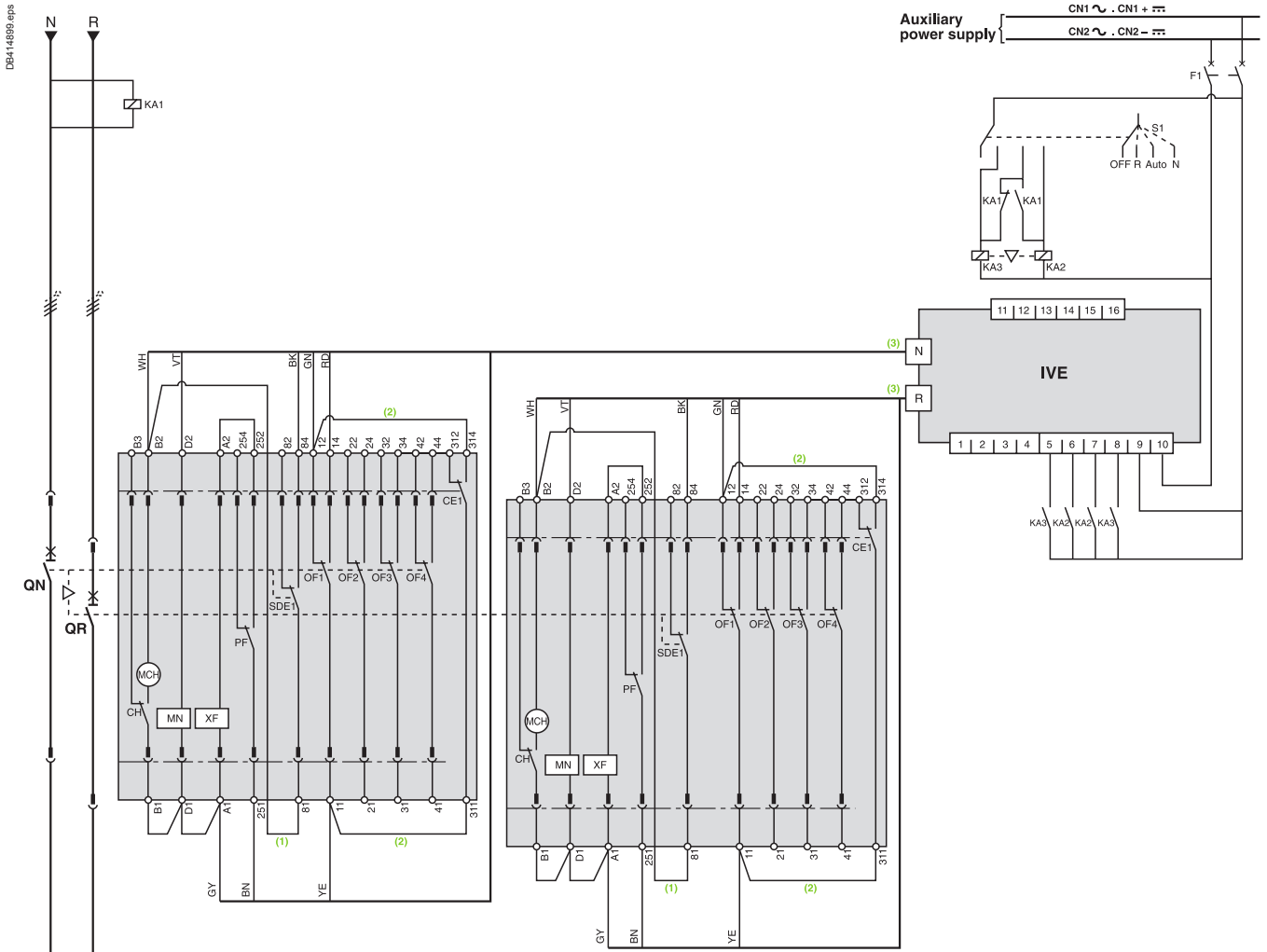

ATTENTION

The diagram shows the electrical wiring for circuit breakers. When wiring the SDE with **switch-disconnectors**, connect wire BK to terminal 82.

- (1) Not to be wired for the "without lockout after a fault" solution.
- (2) Not to be wired on fixed version.
- (3) Prefabricated wiring supplied.

IMPORTANT

The relays controlling the closing order to the "Normal" and "Replacement" circuit breakers must be mechanically and/or electrically interlocked to prevent them from giving simultaneous closing commands.

It is recommended to use Tesys K relays from Schneider Electric reference LC2-K06010●●. These relays are mechanically and electrically interlocked.

Legends

- QN "Normal" source Masterpact NT or NW
- QR "Replacement" source Masterpact NT or NW
- MCH spring-charging motor
- XF standard closing voltage release
- MN undervoltage release
- OF... breaker ON/OFF indication contact
- SDE1 "fault-trip" indication contact
- PF "ready-to-close" contact
- CE1 "connected-position" indication contact (carriage switch)
- CH "springs charged" indication contact
- IVE electrical interlocking and terminal block unit
- F1 auxiliary power supply circuit breaker
- F2 circuit breaker (high breaking capacity)
- S1 control switches
- KA1 auxiliary relays
- KA2 auxiliary relays
- KA3 auxiliary relays

Wiring colour codes

| | | | | | | | |
|-----|-------|-------|--------|--------|------|-------|-------|
| RD | GN | BK | VT | YE | GY | WH | BN |
| red | green | black | violet | yellow | grey | white | brown |

States permitted by mechanical interlocking system

| Normal | Replacement |
|--------|-------------|
| 0 | 0 |
| 1 | 0 |
| 0 | 1 |

Note: diagram shown with circuit breakers in connected position, open, charged, and ready to close. Auxiliary power supply = supply voltage of auxiliary relays (KA...) = supply voltage of electrical auxiliaries (electrical operation, MCH, MN, XF...).

Remote-operated source-changeover systems

2 Masterpact NT or NW devices

Diagram no. 51156905

Automatic-control system for replacement source generator set with lockout after a fault (with MN)

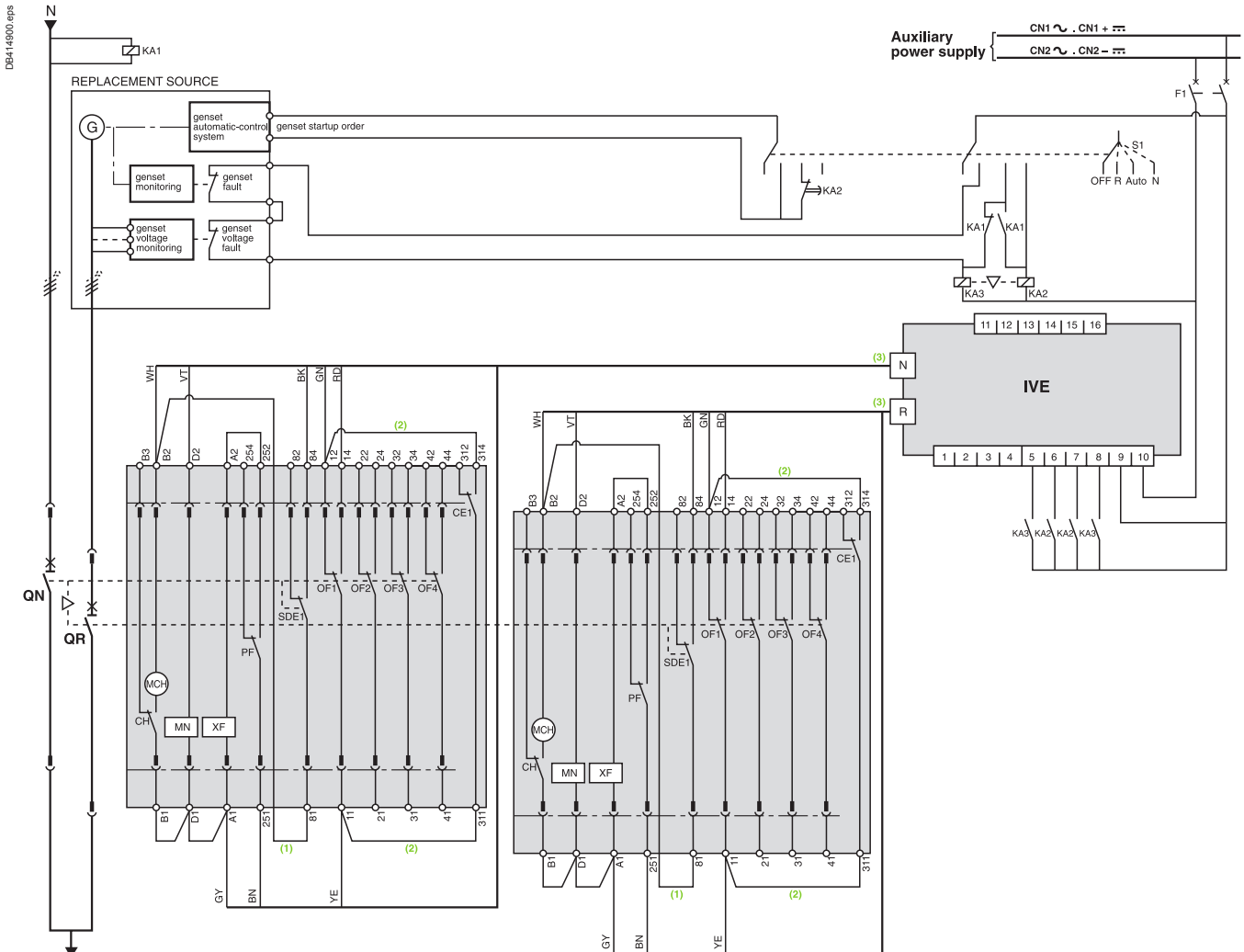

ATTENTION
The diagram shows the electrical wiring for circuit breakers. When wiring the SDE with **switch-disconnectors**, connect **wire BK to terminal 82**.

- (1) Not to be wired for the "without lockout after a fault" solution.
- (2) Not to be wired on fixed version.
- (3) Prefabricated wiring supplied.

IMPORTANT

The relays controlling the closing order to the "Normal" and "Replacement" circuit breakers must be mechanically and/or electrically interlocked to prevent them from giving simultaneous closing commands.

It is recommended to use Tesys K relays from Schneider Electric reference LC2-K06010●●. These relays are mechanically and electrically interlocked.

Legends

- QN "Normal" source Masterpact NT or NW
- QR "Replacement" source Masterpact NT or NW
- MCH spring-charging motor
- XF standard closing voltage release
- MN undervoltage release
- OF... breaker ON/OFF indication contact
- SDE1 "fault-trip" indication contact
- PF "ready-to-close" contact
- CE1 "connected-position" indication contact (carriage switch)
- CH "springs charged" indication contact
- IVE electrical interlocking and terminal block unit
- F1 auxiliary power supply circuit breaker
- F2 circuit breaker (high breaking capacity)
- S1 control switches
- KA1 auxiliary relay
- KA2 time delay for genset startup order to avoid starting the genset for transient UN disturbances
- KA3 auxiliary relay

Wiring colour codes

| | | | | | | | |
|-----|-------|-------|--------|--------|------|-------|-------|
| RD | GN | BK | VT | YE | GY | WH | BN |
| red | green | black | violet | yellow | grey | white | brown |

States permitted by mechanical interlocking system

| Normal | Replacement |
|--------|-------------|
| 0 | 0 |
| 1 | 0 |
| 0 | 1 |

Note: diagram shown with circuit breakers in connected position, open, charged, and ready to close. Auxiliary power supply = supply voltage of auxiliary relays (KA...) = supply voltage of electrical auxiliaries (electrical operation, MCH, MN, XF...).

Remote-operated source-changeover systems

3 Masterpact NW devices

Diagram no. 51 156906

2 normal sources and 1 replacement source: electrical interlocking without lockout after a fault

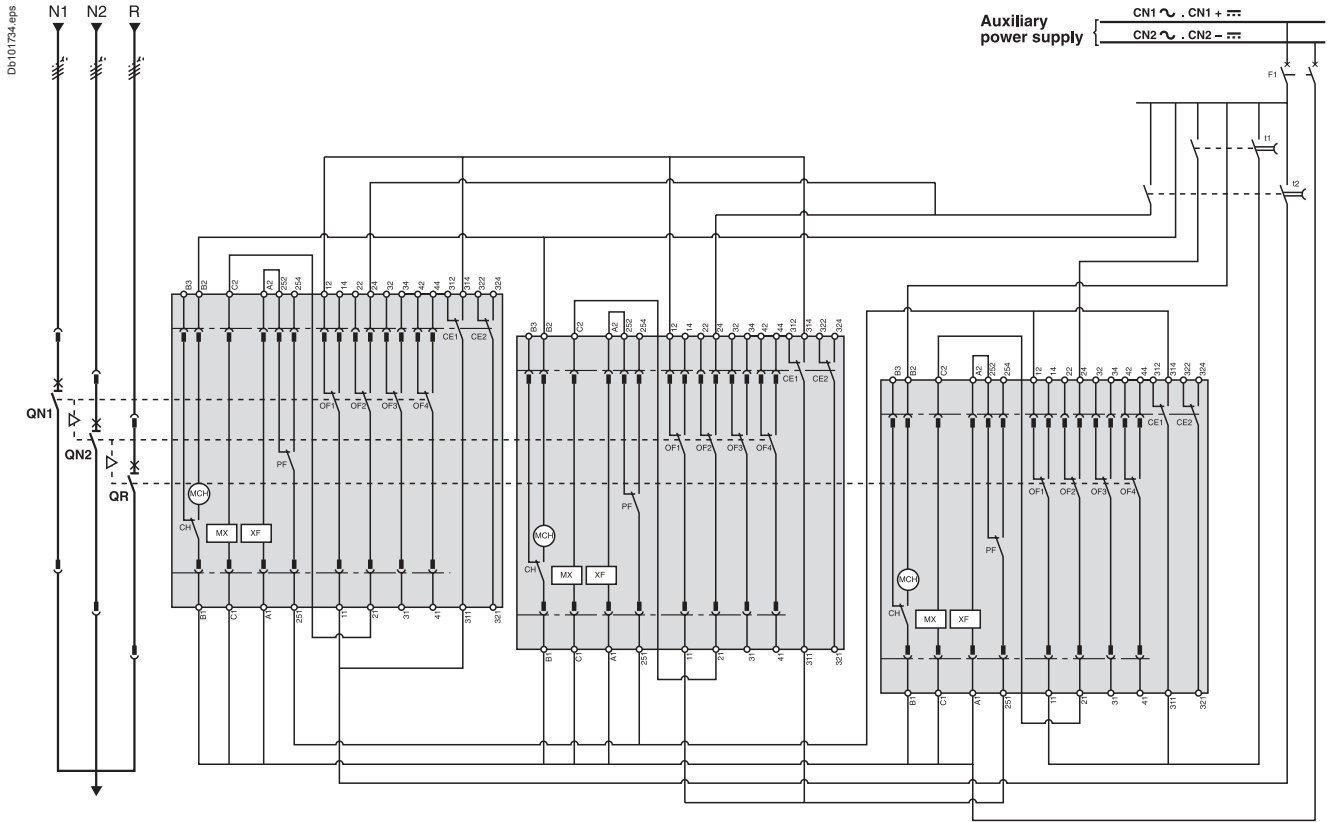

Legends

- QN...** "Normal" source Masterpact NW
- QR** "Replacement" source Masterpact NW
- MCH** spring-charging motor
- MX** standard opening voltage release
- XF** standard closing voltage release
- OF...** breaker ON/OFF indication contact
- PF** "ready-to-close" contact
- CE** "connected-position" indication contact (carriage switch)
- CH** "springs charged" indication contact
- F1** auxiliary power supply circuit breaker
- t1** order for transfer from "R" to "N1 + N2"
(QN1 and QN2 closing time delay = 0.25 sec. minimum)
- t2** order for transfer from "N1 + N2" to "R"
(QR closing time delay = 0.25 sec. minimum)

States permitted by mechanical interlocking system

| Normal 1 | Normal 2 | Replacement |
|----------|----------|-------------|
| 0 | 0 | 0 |
| 1 | 1 | 0 |
| 0 | 0 | 1 |
| 1 | 0 | 0 |
| 0 | 1 | 0 |

Note: diagram shown with circuit breakers in connected position, open, charged, and ready to close.
 Auxiliary power supply = supply voltage of auxiliary relays (KA...) = supply voltage of electrical auxiliaries (electrical operation, MCH, MX, XF...).

Remote-operated source-changeover systems

3 Masterpact NW devices

Diagram no. 51 156907

2 normal sources and 1 replacement source: electrical interlocking with lockout after a fault

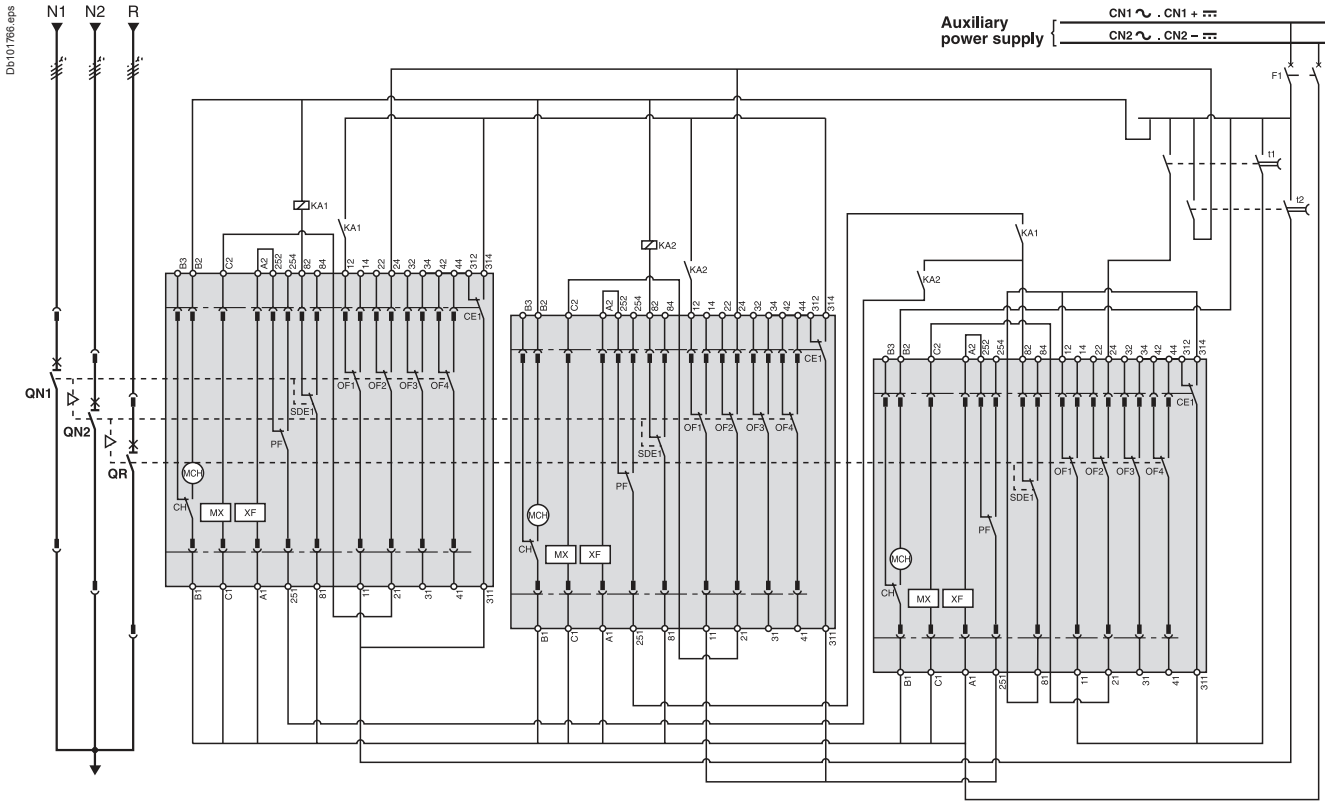

ATTENTION

The diagram shows the electrical wiring for circuit breakers. When wiring the SDE with **switch-disconnectors**, connect the SDE to terminals 81 and 84.

Legends

- QN... "Normal" source Masterpact NW
- QR "Replacement" source Masterpact NW
- MCH spring-charging motor
- MX standard opening voltage release
- XF standard closing voltage release
- OF... breaker ON/OFF indication contact
- SDE1 "fault-trip" indication contact
- PF "ready-to-close" contact
- CE1 "connected-position" indication contact (carriage switch)
- CH "springs charged" indication contact
- F1 auxiliary power supply circuit breaker
- S1 control switches
- S2 source selection switches
- KA1 auxiliary relay
- KA2 auxiliary relays with 10 to 180 sec. time delay
- t1 order for transfer from "R" to "N1 + N2"
(QN1 and QN2 closing time delay = 0.25 sec. minimum)
- t2 order for transfer from "N1 + N2" to "R"
(QR closing time delay = 0.25 sec. minimum)

States permitted by mechanical interlocking system

| Normal 1 | Normal 2 | Replacement |
|----------|----------|-------------|
| 0 | 0 | 0 |
| 1 | 1 | 0 |
| 0 | 0 | 1 |
| 1 | 0 | 0 |
| 0 | 1 | 0 |

Note: diagram shown with circuit breakers in connected position, open, charged, and ready to close.
 Auxiliary power supply = supply voltage of auxiliary relays (KA...) = supply voltage of electrical auxiliaries (electrical operation, MCH, MX, XF...).

Remote-operated source-changeover systems

3 Masterpact NW devices

Diagram no. 51156908

2 normal sources and 1 replacement source: automatic-control system for generator set without lockout after a fault (with MN)

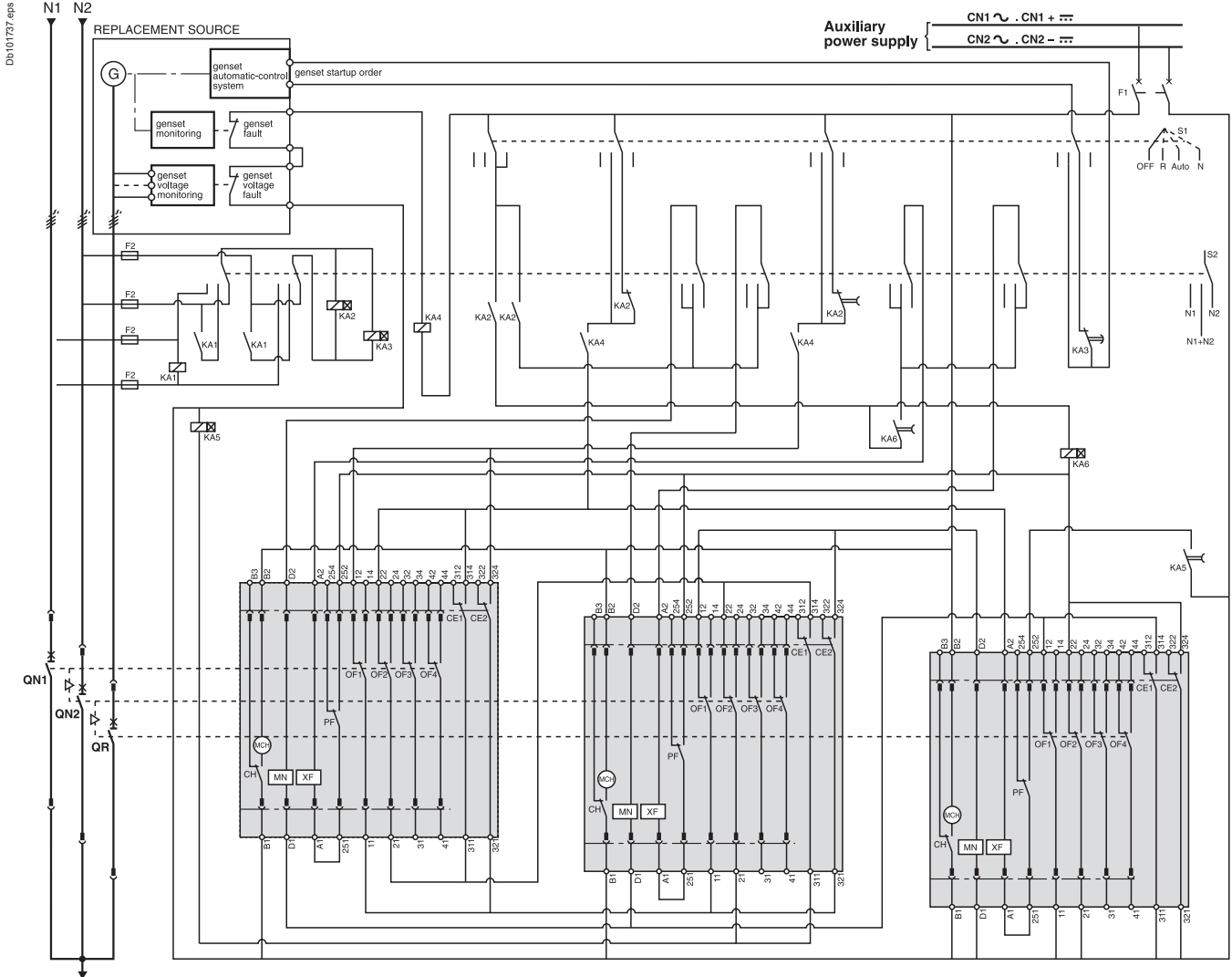

Legends

- QN... "Normal" source Masterpact NW
- QR "Replacement" source Masterpact NW
- MCH spring-charging motor
- XF standard closing voltage release
- MN undervoltage release
- OF... breaker ON/OFF indication contact
- PF "ready-to-close" contact
- CE... "connected-position" indication contact (carriage switch)
- CH "springs charged" indication contact
- F1 auxiliary power supply circuit breaker
- F2/F3 circuit breaker (high breaking capacity)
- S1 control switches
- S2 source selection switches
- KA1 auxiliary relay
- KA2 auxiliary relays with 10 to 180 sec. time delay
- KA3 auxiliary relays with 0.1 to 30 sec. time delay
- KA4 auxiliary relay
- KA5 auxiliary relays with 0.25 sec. time delay
- KA6 auxiliary relays with 0.25 sec. time delay

States permitted by mechanical interlocking system and with associated automatism

| Normal 1 | Normal 2 | Replacement |
|----------|----------|-------------|
| 0 | 0 | 0 |
| 1 | 1 | 0 |
| 0 | 0 | 1 |
| 1 | 0 | 0 |
| 0 | 1 | 0 |

Note: diagram shown with circuit breakers in connected position, open, charged, and ready to close.
 Auxiliary power supply = supply voltage of auxiliary relays (KA...) = supply voltage of electrical auxiliaries (electrical operation, MCH, MN, XF...).

Remote-operated source-changeover systems

3 Masterpact NW devices

Diagram no. 51156909

2 normal sources and 1 replacement source: automatic-control system for generator set with lockout after a fault (with MN)

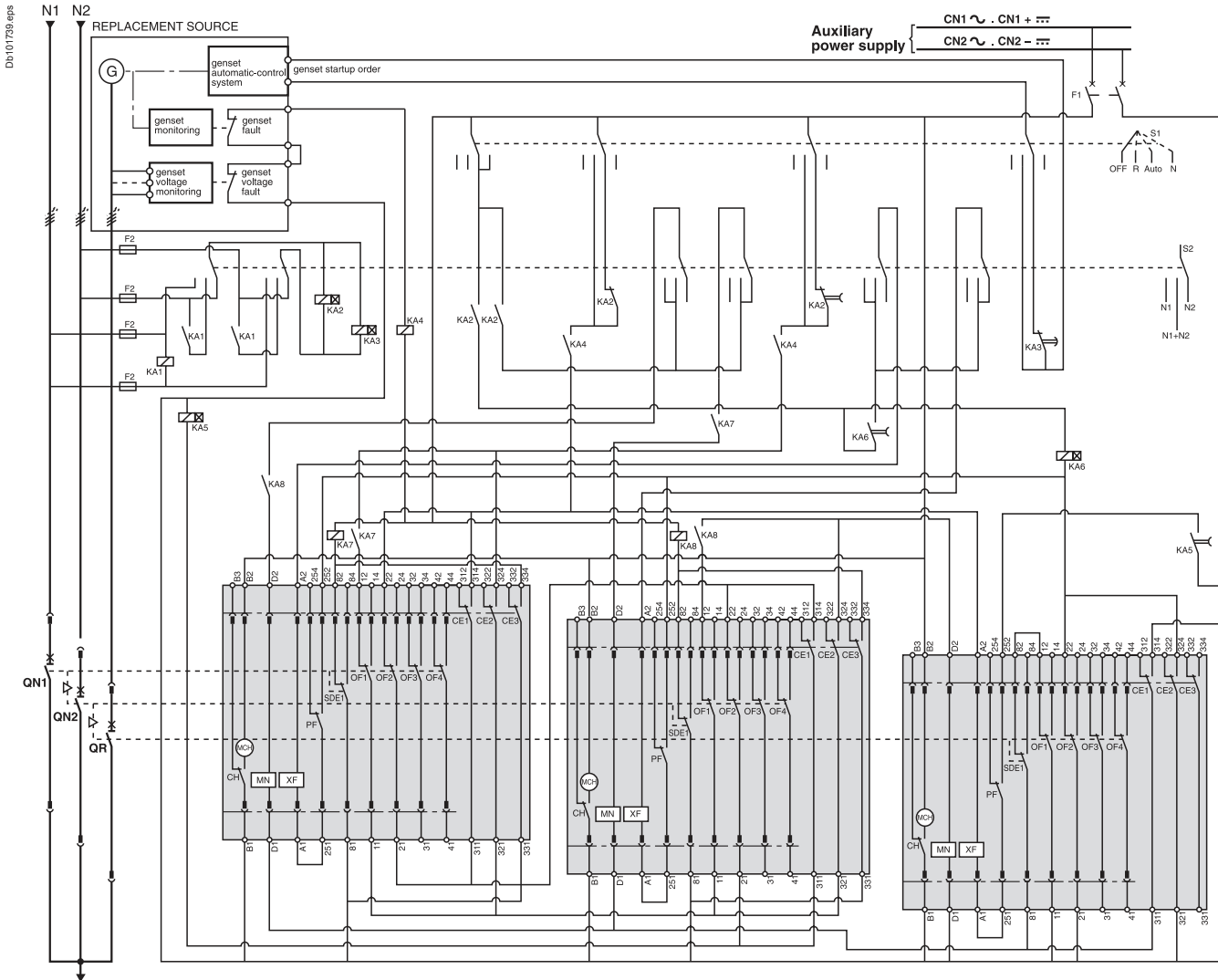

ATTENTION

The diagram shows the electrical wiring for circuit breakers. When wiring the SDE with **switch-disconnectors**, connect the SDE to terminals **81 and 84**.

Legends

- QN... "Normal" source Masterpact NW
- QR "Replacement" source Masterpact NW
- MCH spring-charging motor
- XF standard closing voltage release
- MN undervoltage release
- OF... breaker ON/OFF indication contact
- SDE1 "fault-trip" indication contact
- PF "ready-to-close" contact
- CE... "connected-position" indication contact (carriage switch)
- CH "springs charged" indication contact
- F1 auxiliary power supply circuit breaker
- F2/F3 circuit breaker (high breaking capacity)
- S1 control switches
- S2 source selection switches
- KA1 auxiliary relay
- KA2 auxiliary relays with 10 to 180 sec. time delay
- KA3 auxiliary relays with 0.1 to 30 sec. time delay
- KA4 auxiliary relay
- KA5 auxiliary relays with 0.25 sec. time delay
- KA6 auxiliary relays with 0.25 sec. time delay
- KA7 auxiliary relay
- KA8 auxiliary relay

States permitted by mechanical interlocking system and with associated automatism

| Normal 1 | Normal 2 | Replacement |
|----------|----------|-------------|
| 0 | 0 | 0 |
| 1 | 1 | 0 |
| 0 | 0 | 1 |
| 1 | 0 | 0 |
| 0 | 1 | 0 |

Note: diagram shown with circuit breakers in connected position, open, charged, and ready to close. Auxiliary power supply = supply voltage of auxiliary relays (KA...) = supply voltage of electrical auxiliaries (electrical operation, MCH, MN, XF..).

Remote-operated source-changeover systems

3 Masterpact NW devices

Diagram no. 51156910

3 sources with only 1 device closed: electrical interlocking without lockout after a fault

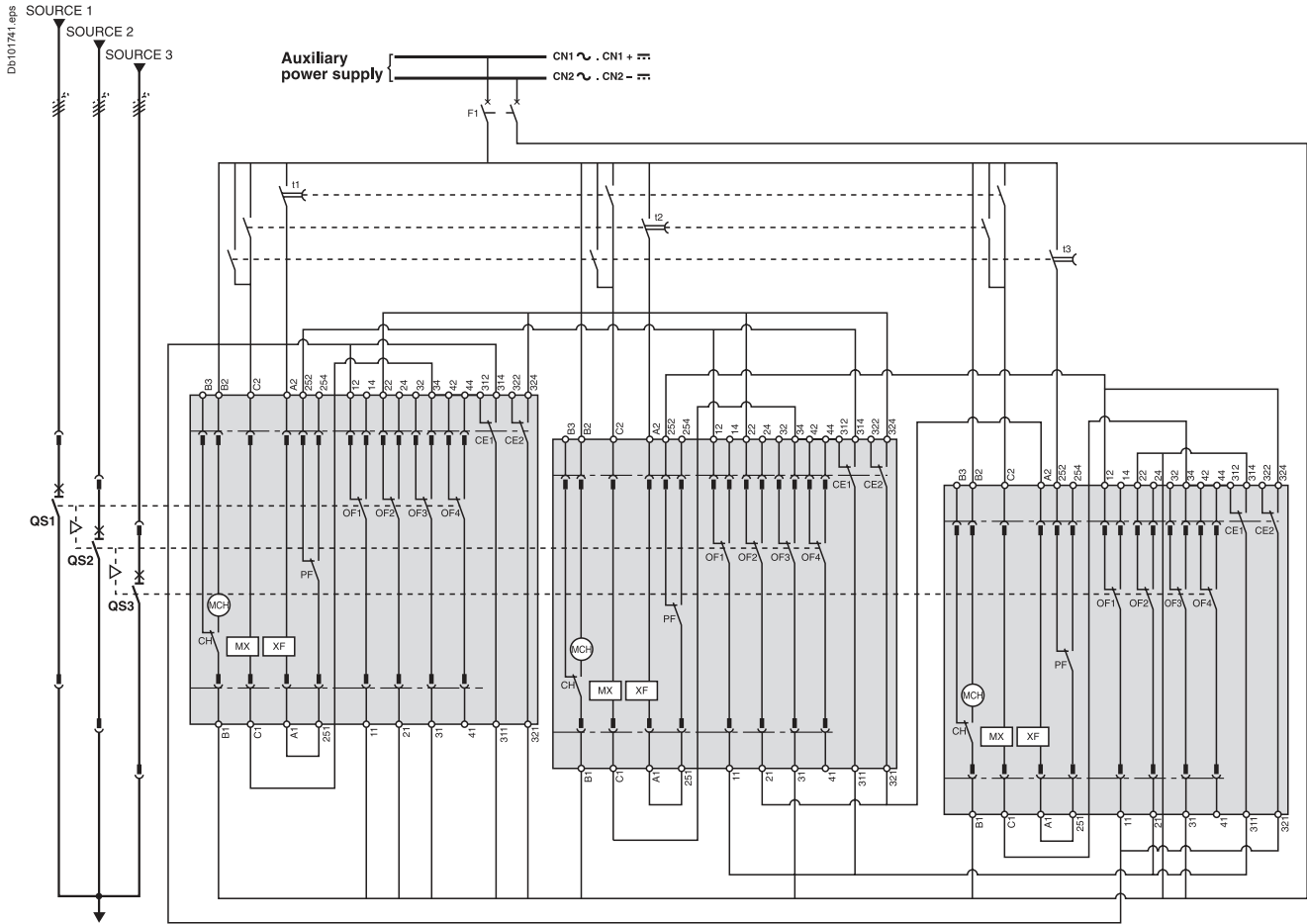

Legends

- QS...** "Source" Masterpact NW
- MCH** spring-charging motor
- MX** standard opening voltage release
- XF** standard closing voltage release
- OF...** breaker ON/OFF indication contact
- PF** "ready-to-close" contact
- CE...** "connected-position" indication contact (carriage switch)
- CH** "springs charged" indication contact
- F1** auxiliary power supply circuit breaker
- t1** order for transfer to "Source 1"
(QS1 closing time delay = 0.25 sec. minimum)
- t2** order for transfer to "Source 2"
(QS2 closing time delay = 0.25 sec. minimum)
- t3** order for transfer to "Source 3"
(QS3 closing time delay = 0.25 sec. minimum)

States permitted by mechanical interlocking system

| Source 1 | Source 2 | Source 3 |
|----------|----------|----------|
| 0 | 0 | 0 |
| 1 | 0 | 0 |
| 0 | 1 | 0 |
| 0 | 0 | 1 |

Note: diagram shown with circuit breakers in connected position, open, charged, and ready to close.
 Auxiliary power supply = supply voltage of auxiliary relays (KA...)
 = supply voltage of electrical auxiliaries (electrical operation, MCH, MX, XF...).

Remote-operated source-changeover systems

3 Masterpact NW devices

Diagram no. 51156911

3 sources with only 1 device closed: electrical interlocking with lockout after a fault

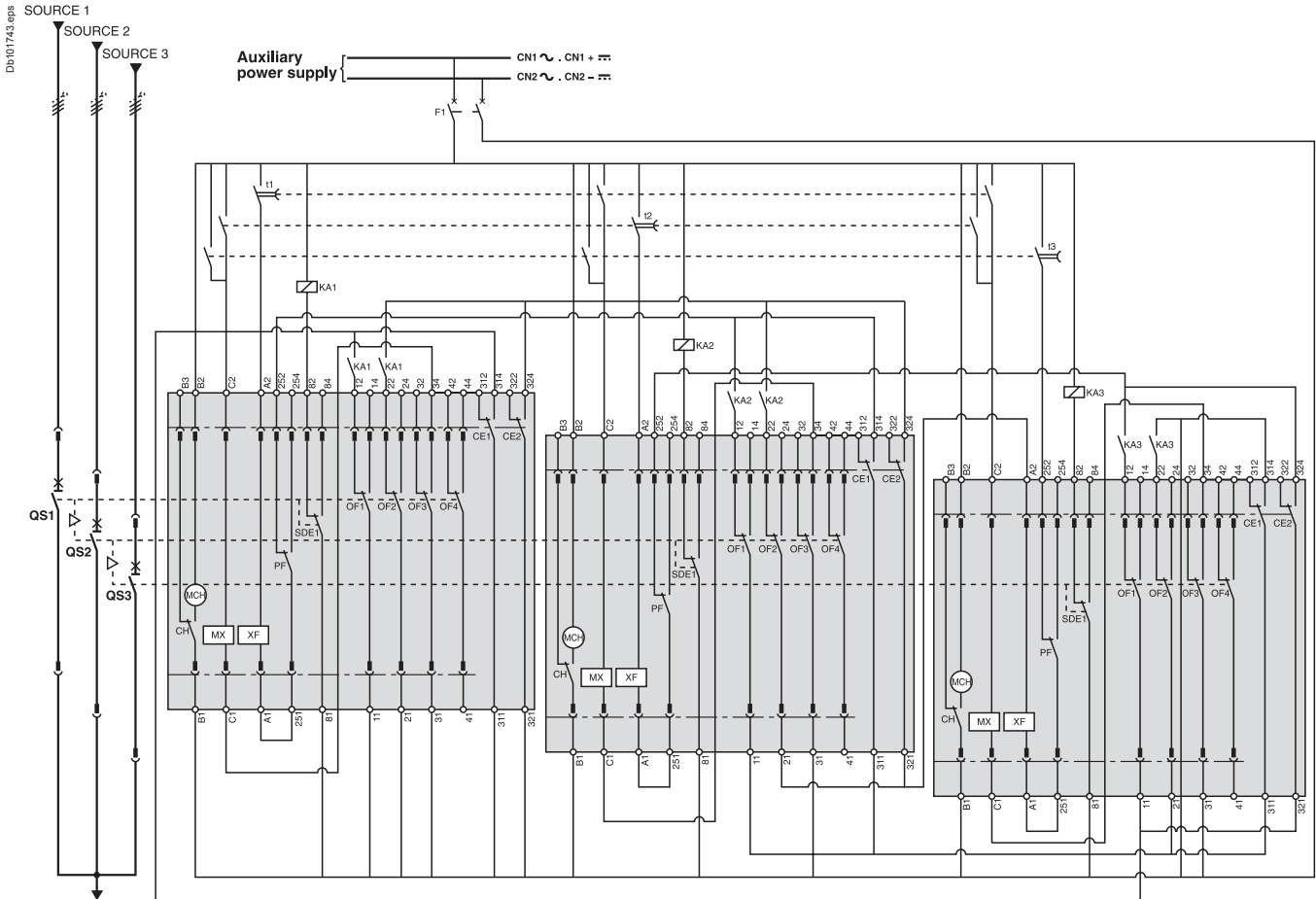

ATTENTION
 The diagram shows the electrical wiring for circuit breakers. When wiring the SDE with **switch-disconnectors**, connect the SDE to terminals 81 and 84.

Legends

- QS...** "Source" Masterpact NW
- MCH** spring-charging motor
- MX** standard opening voltage release
- XF** standard closing voltage release
- OF...** breaker ON/OFF indication contact
- SDE1** "fault-trip" indication contact
- PF** "ready-to-close" contact
- CE...** "connected-position" indication contact (carriage switch)
- CH** "springs charged" indication contact
- F1** auxiliary power supply circuit breaker
- t1** order for transfer to "Source 1"
(QS1 closing time delay = 0,25 sec. minimum)
- t2** order for transfer to "Source 2"
(QS2 closing time delay = 0,25 sec. minimum)
- t3** order for transfer to "Source 3"
(QS3 closing time delay = 0,25 sec. minimum)
- KA1** auxiliary relays
- KA2** auxiliary relays
- KA3** auxiliary relays

States permitted by mechanical interlocking system

| Source 1 | Source 2 | Source 3 |
|----------|----------|----------|
| 0 | 0 | 0 |
| 1 | 0 | 0 |
| 0 | 1 | 0 |
| 0 | 0 | 1 |

Note: diagram shown with circuit breakers in connected position, open, charged, and ready to close. Auxiliary power supply = supply voltage of auxiliary relays (KA...) = supply voltage of electrical auxiliaries (electrical operation, MCH, MX, XF...).

Remote-operated source-changeover systems

3 Masterpact NW devices

Diagram no. 51156912

2 sources and 1 coupling: electrical interlocking without lockout after a fault

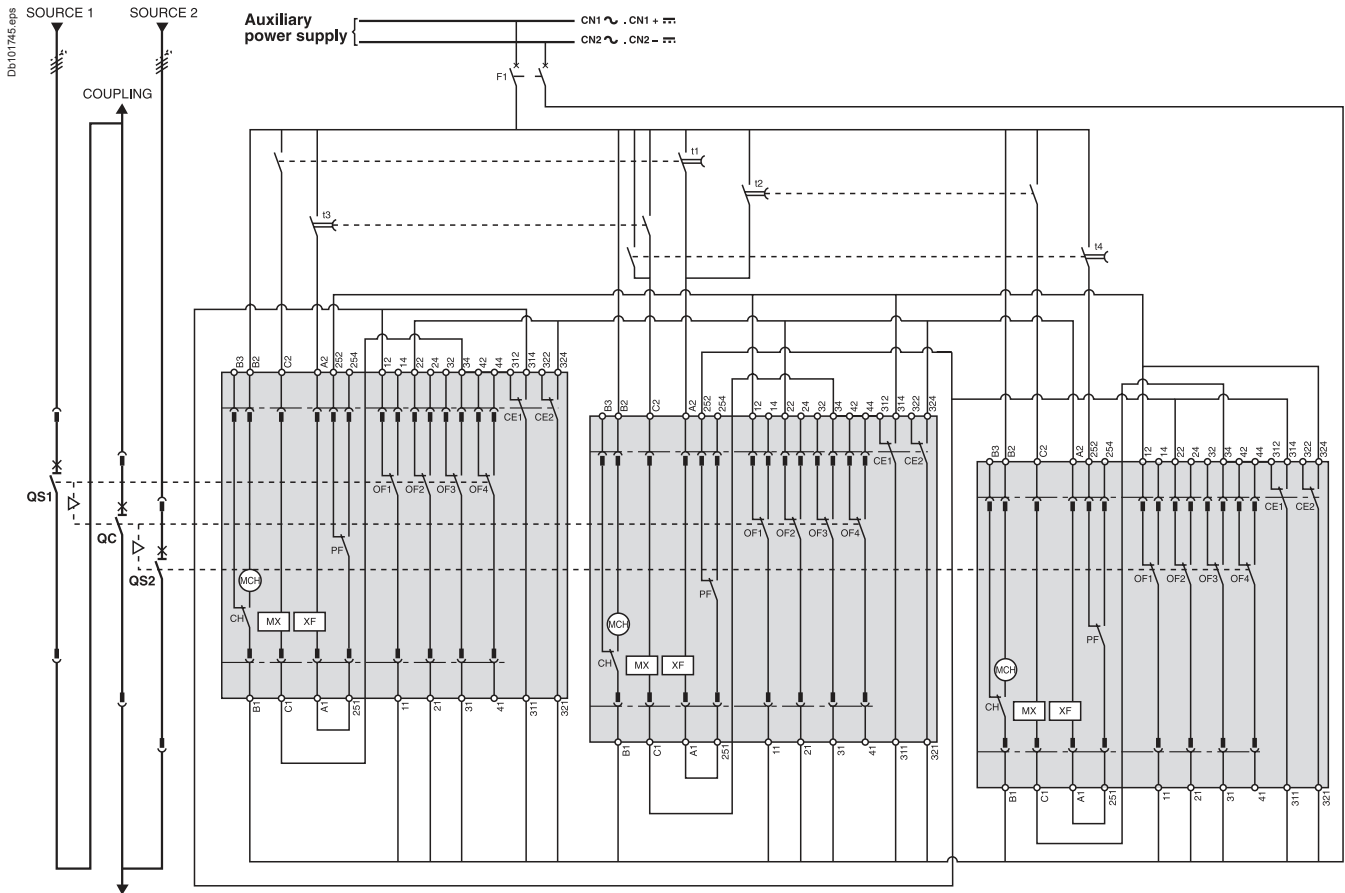

Legends

- QS...** "Source" Masterpact NW
- QC** "Coupling" Masterpact NW
- MCH** spring-charging motor
- MX** standard opening voltage release
- XF** standard closing voltage release
- OF...** breaker ON/OFF indication contact
- PF** "ready-to-close" contact
- CE...** "connected-position" indication contact (carriage switch)
- CH** "springs charged" indication contact
- F1** auxiliary power supply circuit breaker
- t1** coupling order for "Source 1 failure"
(QC closing time delay = 0.25 sec. minimum)
- t2** coupling order for "Source 2 failure"
(QC closing time delay = 0.25 sec. minimum)
- t3** coupling order for "Source 1 restored"
(QS1 closing time delay = 0.25 sec. minimum)
- t4** coupling order for "Source 2 restored"
(QS2 closing time delay = 0.25 sec. minimum)

States permitted by mechanical interlocking system

| Source 1 | Source 2 | Coupling |
|----------|----------|----------|
| 0 | 0 | 0 |
| 1 | 1 | 0 |
| 1 | 0 | 1 |
| 0 | 1 | 1 |
| 1 | 0 | 0 |
| 0 | 1 | 0 |
| 0 | 0 | 1 |

Note: diagram shown with circuit breakers in connected position, open, charged, and ready to close. Auxiliary power supply = supply voltage of auxiliary relays (KA...) = supply voltage of electrical auxiliaries (electrical operation, MCH, MX, XF...).

Remote-operated source-changeover systems

3 Masterpact NW devices

Diagram no. 51156913

2 sources and 1 coupling: electrical interlocking with lockout after a fault

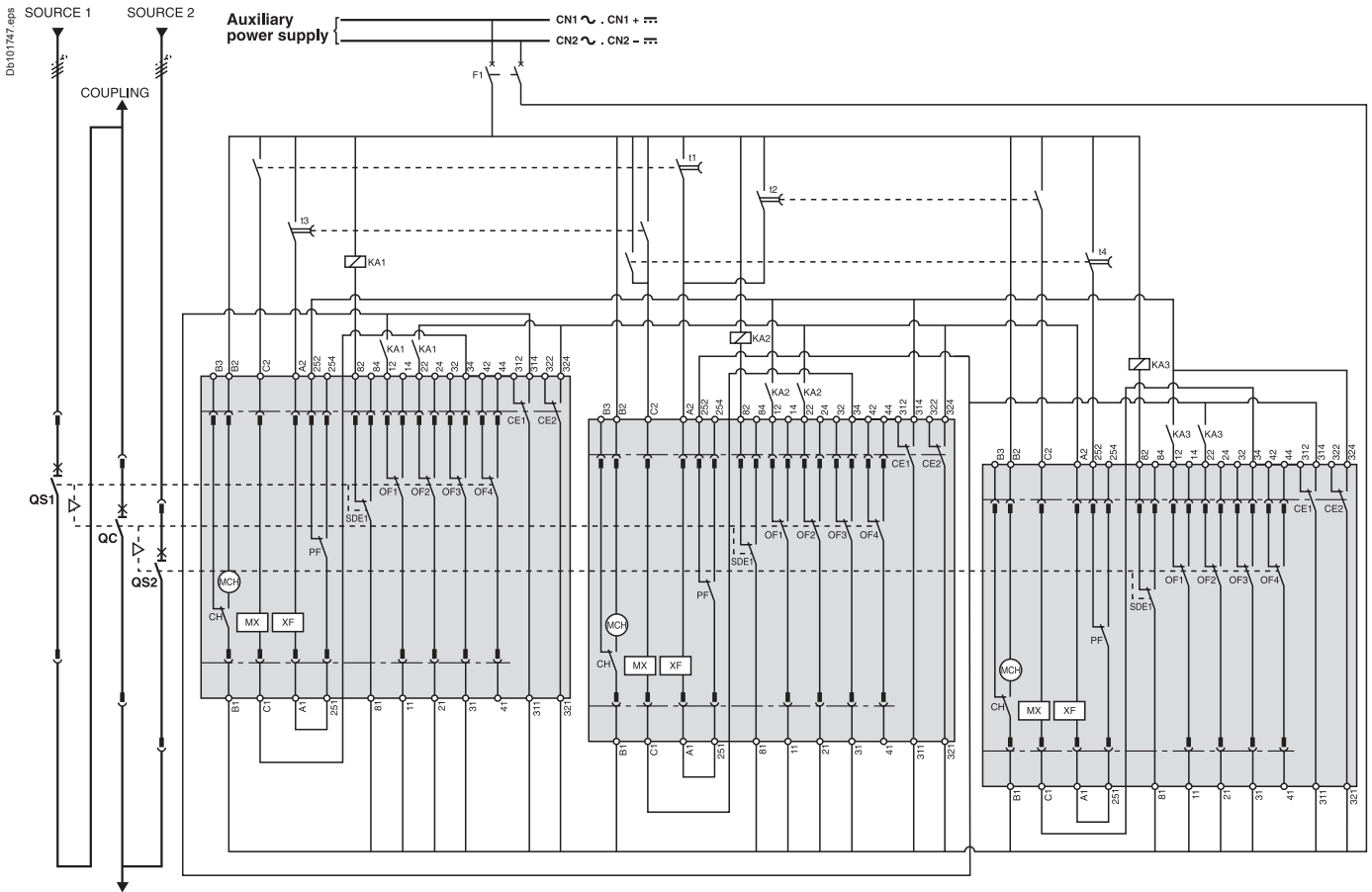

ATTENTION

The diagram shows the electrical wiring for circuit breakers. When wiring the SDE with **switch-disconnectors**, connect the SDE to terminals 81 and 84.

Legends

- QS... "Source" Masterpact NW
- QC "Coupling" Masterpact NW
- MCH spring-charging motor
- MX standard opening voltage release
- XF standard closing voltage release
- OF... breaker ON/OFF indication contact
- SDE1 "fault-trip" indication contact
- PF "ready-to-close" contact
- CE... "connected-position" indication contact (carriage switch)
- CH "springs charged" indication contact
- F1 auxiliary power supply circuit breaker
- t1 coupling order for "Source 1 failure" (QC closing time delay = 0.25 sec. minimum)
- t2 coupling order for "Source 2 failure" (QC closing time delay = 0.25 sec. minimum)
- t3 coupling order for "Source 1 restored" (QS1 closing time delay = 0.25 sec. minimum)
- t4 coupling order for "Source 2 restored" (QS2 closing time delay = 0.25 sec. minimum)
- KA1 auxiliary relays
- KA2 auxiliary relays
- KA3 auxiliary relays

States permitted by mechanical interlocking system

| Source 1 | Source 2 | Coupling |
|----------|----------|----------|
| 0 | 0 | 0 |
| 1 | 1 | 0 |
| 1 | 0 | 1 |
| 0 | 1 | 1 |
| 1 | 0 | 0 |
| 0 | 1 | 0 |
| 0 | 0 | 1 |

Note: diagram shown with circuit breakers in connected position, open, charged, and ready to close. Auxiliary power supply = supply voltage of auxiliary relays (KA...) = supply voltage of electrical auxiliaries (electrical operation, MCH, MX, XF...).

Remote-operated source-changeover systems

3 Masterpact NW devices

Diagram no. 51156914

2 sources and 1 coupling: automatic-control system with lockout after a fault

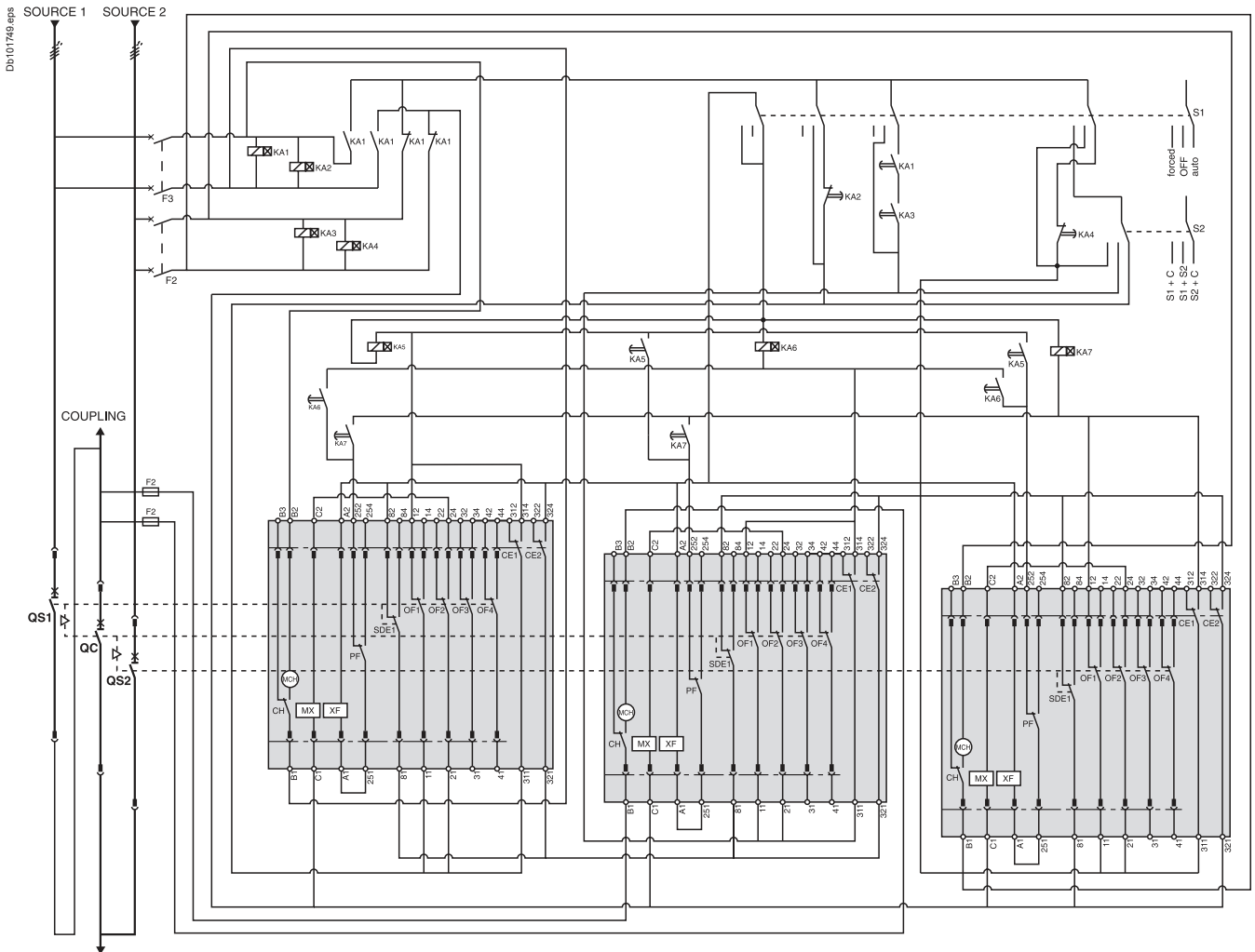

ATTENTION

The diagram shows the electrical wiring for circuit breakers. When wiring the SDE with **switch-disconnectors**, connect the SDE to terminals 81 and 84.

Legends

- QS... "Source" Masterpact NW
- QC "Coupling" Masterpact NW
- MCH spring-charging motor
- MX standard opening voltage release
- XF standard closing voltage release
- OF... breaker ON/OFF indication contact
- SDE1 "fault trip" indication contact
- PF "ready-to-close" contact
- CE... "connected-position" indication contact (carriage switch)
- CH "springs charged" indication contact
- F1 auxiliary power supply circuit breaker
- F2/F3 circuit breaker (high breaking capacity)
- S1 control switches
- S2 source selection switches
- KA1 auxiliary relays with 10 to 180 sec. time delay
- KA2 auxiliary relays with 0.1 to 30 sec. time delay
- KA3 auxiliary relays with 10 to 180 sec. time delay
- KA4 auxiliary relays with 0.1 to 30 sec. time delay
- KA5 auxiliary relays with 0.25 sec. time delay
- KA6 auxiliary relays with 0.25 sec. time delay
- KA7 auxiliary relays with 0.25 sec. time delay

States permitted by mechanical interlocking system and with associated automatism

| Source 1 | Source 2 | Coupling |
|----------|----------|----------|
| 0 | 0 | 0 |
| 1 | 1 | 0 |
| 1 | 0 | 1 |
| 0 | 1 | 1 |
| 1 | 0 | 0 |
| 0 | 1 | 0 |
| 0 | 0 | 1 |

Note: diagram shown with circuit breakers in connected position, open, charged, and ready to close. Auxiliary power supply = supply voltage of auxiliary relays (KA...) = supply voltage of electrical auxiliaries (electrical operation, MCH, MX, XF...).

Source-changeover systems with automatic controllers

2 Masterpact NT or NW devices

Diagram no. 51156903

Electrical interlocking with lockout after a fault

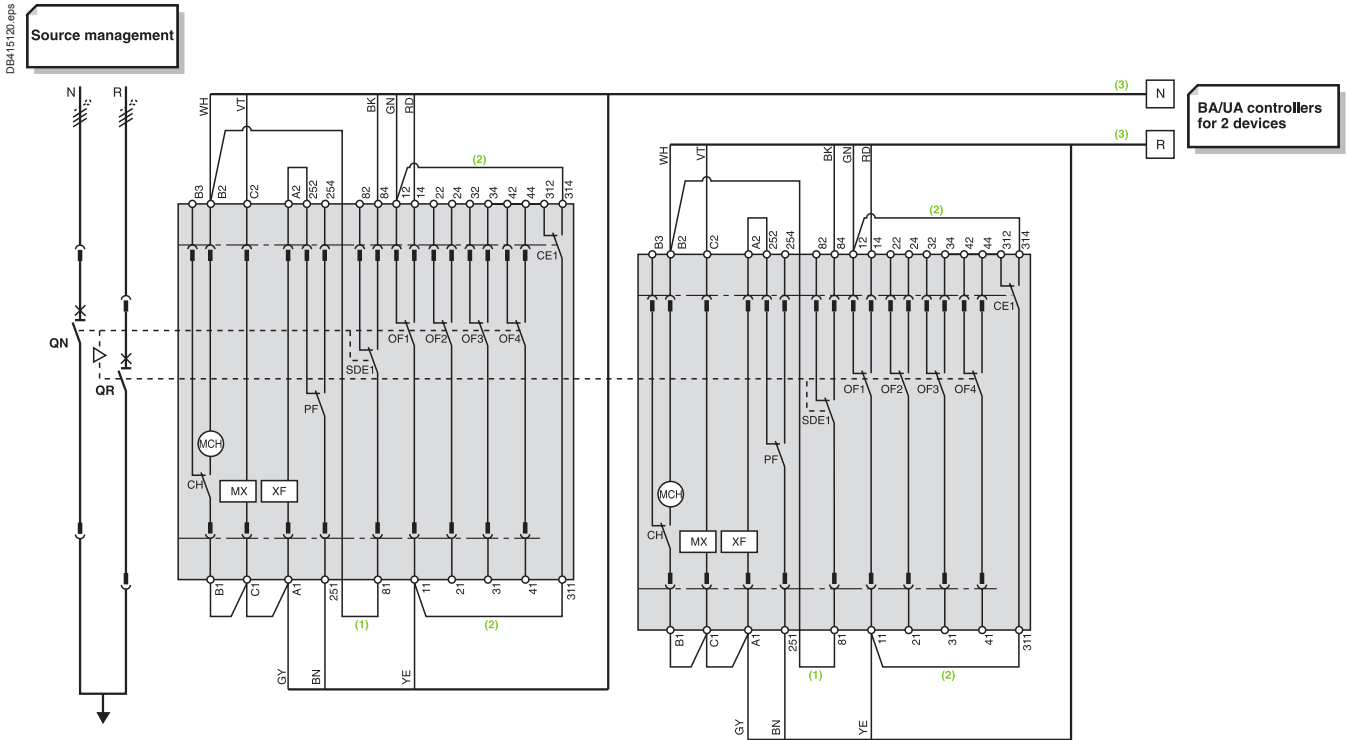

ATTENTION
The diagram shows the electrical wiring for circuit breakers. When wiring the SDE1 with **switch-disconnectors**, connect wire BK to terminal 82.

- (1) Not to be wired for the "without lockout after a fault" solution.
- (2) Not to be wired on fixed version.
- (3) Prefabricated wiring supplied.

Legends

- QN "Normal" source Masterpact NT or NW
- QR "Replacement" source Masterpact NT or NW
- MCH spring-charging motor
- MX standard opening voltage release
- XF standard closing voltage release
- OF... breaker ON/OFF indication contact
- SDE1 "fault-trip" indication contact
- PF "ready-to-close" contact
- CE1 "connected-position" indication contact (carriage switch)
- CH "springs charged" indication contact

Wiring colour codes

| | | | | | | | |
|-----|-------|-------|--------|--------|------|-------|-------|
| RD | GN | BK | VT | YE | GY | WH | BN |
| red | green | black | violet | yellow | grey | white | brown |

States permitted by mechanical interlocking system

| Normal | Replacement |
|--------|-------------|
| 0 | 0 |
| 1 | 0 |
| 0 | 1 |

Note: diagram shown with circuit breakers in connected position, open, charged, and ready to close.

| | |
|--------------------------------------|-----|
| <i>Presentation</i> | 2 |
| <i>Functions and characteristics</i> | A-1 |
| <i>Dimensions</i> | B-1 |
| <i>Electrical diagrams</i> | C-1 |

Source-changeover systems for 2 devices

| | |
|--|-----|
| Compact INS40 to INS2500 and INV100 to INV2500 | D-2 |
| Compact NSX100 to NSX630 | D-3 |
| Compact NS630b to NS1600 circuit breakers and switch-disconnectors | D-5 |
| Masterpact NT circuit breakers and switch-disconnectors | D-7 |

Source-changeover systems for 2 or 3 devices

| | |
|---|-----|
| Masterpact NW circuit breakers and switch-disconnectors | D-8 |
|---|-----|

Source-changeover systems for 2 devices

| | |
|--|------|
| Compact INS40 to INS630 switch-disconnectors | D-10 |
| Compact NSX100 to NSX630 / circuit breakers and switch-disconnectors | D-12 |
| Compact NS630b to NS1600 / circuit breakers and switch-disconnectors | D-14 |
| Masterpact NT or NW / circuit breakers and switch-disconnectors | D-16 |

Source-changeover systems for 3 devices

| | |
|---|------|
| Masterpact NW / circuit breakers and switch-disconnectors | D-18 |
|---|------|

Source-changeover systems for 2 devices

Compact INS40 to INS2500
and INV100 to INV2500

Manual source-changeover systems Compact INS40 to INS630 and INV100 to INV630

Interlocking for rotary handle

| | | | |
|------------------|--|------|-------|
| DB107710.eps | Mechanical device for INS40 to INS160 equipped with an extended rotary handle | 3/4P | 28953 |
| | Mechanical device for INS250-100 to INS250/INV100 to INV250 equipped with a direct or extended rotary handle | | 31073 |
| DB404077.eps | Mechanical device for INS/INV320 to INS/INV630 equipped with a direct or extended rotary handle | | 31074 |

Complete assembly source-changeover systems Compact INS250 to INS630

| | | | | | |
|--|--|-----------------------------------|-------|-------|----------|
| DB404770.eps | With Compact INS250-100A | 3P | 31140 | 4P | 31141 |
| | With Compact INS250-160A | | 31144 | | 31145 |
| | With Compact INS250-200A | | 31142 | | 31143 |
| | With Compact INS250 | | 31146 | | 31147 |
| | With Compact INS320 | | 31148 | | 31149 |
| | With Compact INS400 | | 31150 | | 31151 |
| | With Compact INS500 | | 31152 | | 31153 |
| With Compact INS630 | | 31154 | | 31155 | |
| Locking for INS complete source changeover assembly | | | | | |
| DB107711.eps | Handle locking by 1 to 3 padlocks (in OFF position) | | | | Built in |
| | By keylock | Keylocking device | | | 31097 |
| | | + Ronis 1351B.500 keylock | | | 41940 |
| | | or + Profalux KS5 B24 D4Z keylock | | | 42888 |
| Rotary handle | | | | | |
| DB404079.eps | Extended front control for complete source changeover assembly | | | | 31055 |

Manual source-changeover systems Compact INS250 to INS2500 and INV250 to INV2500 by keylock

Interlocking

| | | | | |
|------------------|---|----|------|-------|
| DB10549.eps | Locking device for Ronis/Profalux keylocks on INS250-100 to INS250/INV100 to INV250 | 2x | 3/4P | 31087 |
| | Locking device for Ronis/Profalux keylocks on INS/INV320 to INS/INV630 | 2x | | 31088 |
| DB404080.eps | Locking device for Ronis/Profalux keylocks on INS/INV630b to INS/INV2500 | 2x | | 31291 |
| | + Ronis 1351B.500 keylock (2 keylocks / 1 key) | | | 41950 |
| | or + Profalux KS5 B24 D4Z keylock (2 keylocks / 1 key) | | | 42878 |

Connection accessories

Downstream coupling accessories

| | | | | | |
|---|---|--|------|----------|--|
| Short terminal shields (1 pair) + "normal" source/"replacement" source | | | | | |
| DB101082.eps | INS250/INS250 | | 3/4P | LV429359 | |
| | INS320 to INS630/INS320 to INS630 | | | LV432620 | |
| Long terminal shields (1 piece) | | | | | |
| DB403921.eps | INS250 long terminal shield | | | LV429518 | |
| | INS320 to INS630 | | | | |
| | Long terminal shield, 45 mm (1 piece) | | | LV432594 | |
| | Long terminal shield for spreaders, 52.5 mm (1 piece) | | | LV432596 | |

Terminal extensions

| | | | | |
|------------------|-----------|---------|----|----------|
| DB115652.eps | Spreaders | 52.5 mm | 4P | LV432491 |
|------------------|-----------|---------|----|----------|

Manual source changeover

Mechanical interlocking

DB404083.eps



| | | |
|--|--------------|----------|
| For toggle controlled circuit breakers | NSX100...250 | LV429354 |
| | NSX400...630 | LV432614 |

DB404084.eps



| | | |
|-------------------------------------|--------------|----------|
| For rotary handled circuit breakers | NSX100...250 | LV429369 |
| | NSX400...630 | LV432621 |

Key lock interlocking

DB404085.eps

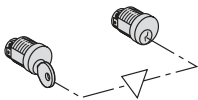

| | | |
|--|----------------------|-------|
| For rotary handled or remote controlled circuit breakers | | |
| 2 locks, 1 key | Ronis 1351B.500 | 41950 |
| | Profalux KS5 B24 D4Z | 42878 |

Remote controlled source changeover

Plate + IVE unit

DB404086.eps

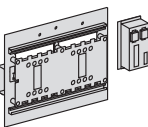

| Source "normal"/source "replacement" (identical voltages) | 24 to 250 V DC | 48 to 415 V AC 50/60 Hz 440 V 60 Hz |
|---|------------------|--|
| NSX100...250/NSX100...250 | | |
| Plate + IVE unit ⁽¹⁾ | 29351 | 29350 |
| Plate | 29349 | 29349 |
| IVE unit | 29356 | 29352 |
| Auxiliary switches 2 OF + 2 SDE | 4 x 29450 | 4 x 29450 |
| Spare wiring system (device/IVE unit) | 29365 | 29365 |
| Back sockets option add: Only long RC | ⁽²⁾ | ⁽²⁾ |
| Plug in base option add: Plug in kit | ⁽²⁾ | ⁽²⁾ |
| NSX400...630/NSX100...630 | | |
| Plate + IVE unit ⁽¹⁾ | 32611 | 32610 |
| Plate | 32609 | 32609 |
| IVE unit | 29356 | 29352 |
| Auxiliary switches 2 OF + 2 SDE | 4 x 29450 | 4 x 29450 |
| Spare wiring system (device/IVE unit) | 29365 | 29365 |
| Back sockets option add: Only long RC | ⁽²⁾ | ⁽²⁾ |
| Plug in base option add: Plug in kit | ⁽²⁾ | ⁽²⁾ |
| Adaptator kit for NSX100...250 | 1 x 32618 | 1 x 32618 |

Control unit option

DB404087.eps

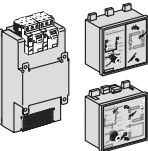

| | 110/127 V AC 50/60 Hz | 220/240 V AC 50/60 Hz | 380/415 V AC 50/60 Hz 440 V 60 Hz |
|--|-----------------------|-----------------------|--------------------------------------|
| ACP + controller BA ⁽¹⁾ | | 29470 | 29471 |
| Plate ACP | | 29363 | 29364 |
| Controller BA | | 29376 | 29377 |
| ACP + controller UA ⁽¹⁾ | 29448 | 29472 | 29473 |
| Plate ACP | 29447 | 29363 | 29364 |
| Controller UA | 29446 | 29378 | 29380 |
| ACP + controller UA150 ⁽¹⁾ (communication option) | | 29474 | 29475 |
| Plate ACP | | 29363 | 29364 |
| Controller UA150 | | 29379 | 29381 |

Wiring cable between BA/UA and ACP/IVE

| | | |
|--------------------------|--------------|--------------|
| Wiring cable (1.5 meter) | 29368 | 29368 |
|--------------------------|--------------|--------------|

Communication module

DB403922.eps

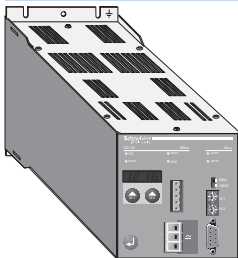

| | |
|--|--------------|
| DC150 data concentrator 110-240 V AC / 115-125 V DC | 50823 |
|--|--------------|

⁽¹⁾ The supply voltages BA/UA controller, ACP plate, IVE unit and the remote control must be identical whatever the source changeover type.

⁽²⁾ See products pages.

Connection accessories

Downstream coupling accessories

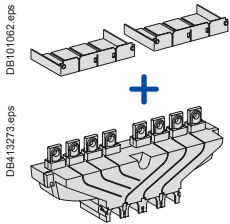

Short terminal shields (1 pair) + "normal" source/"replacement" source

| | 3P | 4P |
|-----------------------------------|----------|----------|
| NSX100...250/NSX100...250 / 250 A | LV429358 | LV429359 |
| NSX400...630/NSX400...630 / 630 A | LV432619 | LV432620 |

Long terminal shields (1 piece)

| | 3/4P |
|---|----------|
| NSX100...250 long terminal shield | LV429518 |
| NSX400...630 | |
| Long terminal shield, 45 mm (1 piece) | LV432594 |
| Long terminal shield for spreaders, 52.5 mm (1 piece) | LV432596 |

Terminal extensions



| Spreaders | 52.5 mm | 4P | LV432491 |
|-----------|---------|----|----------|
|-----------|---------|----|----------|

Typical composition of remote controlled source changeover

Remote controlled source changeover

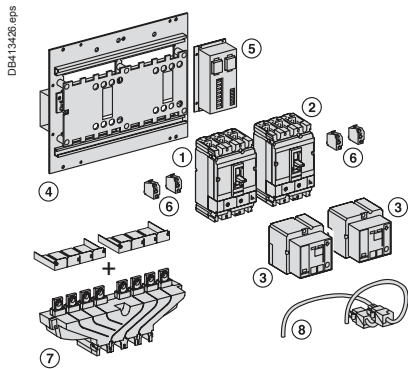

- 1 normal device N (1)
- + 1 replacement device R (2)
- + 2 remote controls (3)
- + 1 plate with interlocking (4) with IVE (5) and its wiring (8)
- + 2 plug-in kits (if plug-in version)
- + 1 adaptor kit for NSX100...250 plug-in (if NSX400...630 with NSX100...250)
- + auxiliary switches (6)
- 2 x (1 OF + 1 SDE) for Compact NSX100...630
- + 1 downstream coupling accessory (7) for Compact NSX100...630 (option)
- + long RC (if back connection)

IVE voltages and remote controls are identical.

Associated control unit

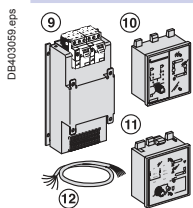

- 1 source changeover without associated control unit
- + 1 ACP (9) with BA control unit (10)
- Or + 1 ACP (9) with UA control unit (11)
- Or + 1 ACP (9) with UA150 control unit (11)
- + extension (12) for remote UA/BA connection on front of switchboard

IVE voltages + remote control + ACP + BA or UA are identical.

Source-changeover systems for 2 devices

Compact NS630b to NS1600
circuit breakers and switch-disconnectors

Interlocking for source-changeover systems

Mechanical interlocking

DB404090.eps

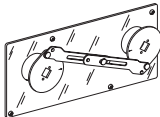

For 2 devices with extended rotary handles

33890

Interlocking using connecting rods for Compact electrically-operated devices

DB404091.eps

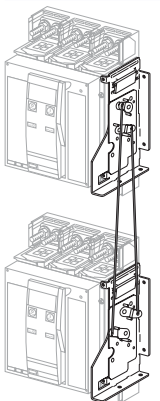

Complete assembly with 2 adaptation fixtures + rods

2 Compact fixed devices

33910

2 Compact withdrawable devices

33913

Interlocking using cables for Compact electrically-operated devices

DB404092.eps

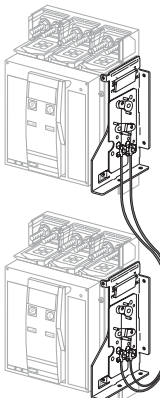

Complete assembly with 2 adaptation fixtures + cables

2 Compact fixed devices

33911

2 Compact withdrawable devices

33914

1 Compact fixed + 1 Compact withdrawable device

33915

Source-changeover systems for 2 devices

Compact NS630b to NS1600 circuit
breakers and switch-disconnectors (cont.)

Associated controller

The automatic-control option includes:

- an IVE electrical-interlocking unit
- an ACP control plate
- a BA or UA controller, depending on the required functions
- a UA/BA adapter kit.

Note: the circuit breaker auxiliaries (MCH, MX, XF) and the automatic-control components (IVE, ACP, UA or BA) must have the same voltages.

IVE electrical-interlocking unit

DB404093.eps

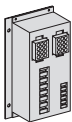

| | 24 to 250 V DC | 48/415 V AC 50/60 Hz 440 V 60 Hz |
|---|----------------|-------------------------------------|
| For 2 devices | 29356 | 29352 |
| Wiring kit for connection of 2 fixed/withdrawable devices to the IVE unit | | 54655 |

Control unit option

DB404087.eps

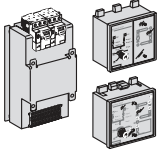

| | 110/127 V AC 50/60 Hz | 220/240 V AC 50/60 Hz | 380/415 V AC 50/60 Hz 440 V 60 Hz |
|--|-----------------------|-----------------------|--------------------------------------|
| ACP + controller BA ⁽¹⁾ | | 29470 | 29471 |
| Plate ACP | | 29363 | 29364 |
| Controller BA | | 29376 | 29377 |
| ACP + controller UA ⁽¹⁾ | 29448 | 29472 | 29473 |
| Plate ACP | 29447 | 29363 | 29364 |
| Controller UA | 29446 | 29378 | 29380 |
| ACP + controller UA150 ⁽¹⁾ (communication option) | | 29474 | 29475 |
| Plate ACP | | 29363 | 29364 |
| Controller UA150 | | 29379 | 29381 |

Communication module

DB403922.eps

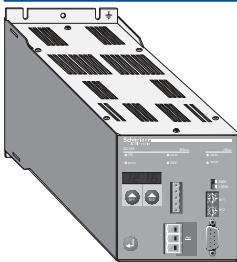

| | |
|--|--------------|
| DC150 data concentrator 110-240 V AC / 115-125 V DC | 50823 |
|--|--------------|

⁽¹⁾ The supply voltages of the BA/UA controller, ACP plate, IVE unit and circuit breaker operating mechanism must be identical whatever the type of source-changeover system.

Interlocking for source-changeover systems

Interlocking using connecting rods

DB404054 eps

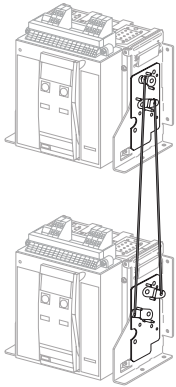

| | |
|---|-------|
| Complete assembly with 2 adaptation fixtures + rods | |
| 2 Masterpact NT fixed devices | 33912 |
| 2 Masterpact NT drawout devices | 33913 |

Interlocking using cables (*)

| | |
|---|-------|
| Choose 2 adaptation fixtures (1 for each breaker + 1 set of cables) | |
| 1 adaptation fixture for Masterpact NT fixed devices | 33200 |
| 1 adaptation fixture for Masterpact NT drawout devices | 33201 |
| 1 set of 2 cables | 33209 |

(*) Can be used with any combination of NT or NW, fixed or drawout devices.

Associated controller

The automatic-control option includes:

- an IVE electrical-interlocking unit
- an ACP control plate
- a BA or UA controller, depending on the required functions
- a UA/BA adapter kit.

Note: the circuit breaker auxiliaries (MCH, MX, XF) and the automatic-control components (IVE, ACP, UA or BA) must have the same voltages.

IVE electrical-interlocking unit

DB404030 eps

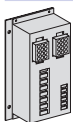

| | | |
|--|----------------|-------------------------------------|
| | 24 to 250 V DC | 48/415 V AC 50/60 Hz 440 V 60 Hz |
| For 2 devices | 29356 | 29352 |
| Wiring kit for connection of 2 fixed/drawout devices to the IVE unit | | 54655 |

Control unit option

DB404087 eps

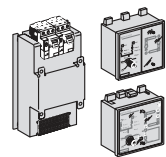

| | 110/127 V AC 50/60 Hz | 220/240 V AC 50/60 Hz | 380/415 V AC 50/60 Hz 440 V 60 Hz |
|--|-----------------------|-----------------------|--------------------------------------|
| ACP + controller BA ⁽¹⁾ | | 29470 | 29471 |
| Plate ACP | | 29363 | 29364 |
| Controller BA | | 29376 | 29377 |
| ACP + controller UA ⁽¹⁾ | 29448 | 29472 | 29473 |
| Plate ACP | 29447 | 29363 | 29364 |
| Controller UA | 29446 | 29378 | 29380 |
| ACP + controller UA150 ⁽¹⁾ (communication option) | | 29474 | 29475 |
| Plate ACP | | 29363 | 29364 |
| Controller UA150 | | 29379 | 29381 |

Communication module

DB403922 eps

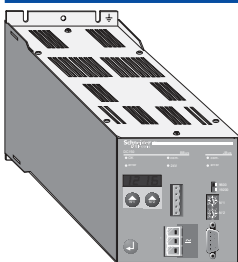

| | |
|--|-------|
| DC150 data concentrator 110-240 V AC / 115-125 V DC | 50823 |
|--|-------|

(1) The supply voltages of the BA/UA controller, ACP plate, IVE unit and circuit breaker operating mechanism must be identical whatever the type of source-changeover system.

Source-changeover systems for 2 or 3 devices

Masterpact NW circuit breakers and switch-disconnectors

Interlocking for source-changeover systems for 2 devices

Interlocking of 2 devices using connecting rods

DB4C4055.eps

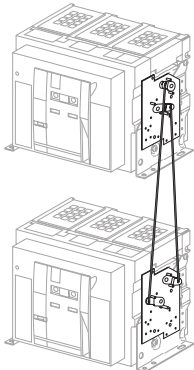

Complete assembly with 2 adaptation fixtures + rods

2 Masterpact NW fixed devices **48612**

2 Masterpact NW drawout devices **48612**

Can be used with 1 NW fixed + 1 NW drawout.

Interlocking of 2 devices using cables (*)

Choose 2 adaptation fixtures (1 for each breaker + 1 set of cables)

1 adaptation fixture for Masterpact NW fixed devices **47926**

1 adaptation fixture for Masterpact NW drawout devices **47926**

1 set of 2 cables **33209**

(*) *Can be used with any combination of NT or NW, fixed or drawout devices.*

Associated controller for 2 devices

The automatic-control option includes:

- an IVE electrical-interlocking unit
- an ACP control plate
- a BA or UA controller, depending on the required functions
- a UA/BA adapter kit.

Note: the circuit breaker auxiliaries (MCH, MX, XF) and the automatic-control components (IVE, ACP, UA or BA) must have the same voltages.

IVE electrical-interlocking unit

DB4C4093.eps

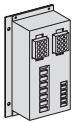

| | 24 to 250 V DC | 48/415 V AC 50/60 Hz 440 V 60 Hz |
|--|----------------|-------------------------------------|
| For 2 devices | 29356 | 29352 |
| Wiring kit for connection of 2 fixed/drawout devices to the IVE unit | | 54655 |

Control unit option

DB4C4087.eps

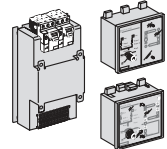

| | 110/127 V AC 50/60 Hz | 220/240 V AC 50/60 Hz | 380/415 V AC 50/60 Hz 440 V 60 Hz |
|---|-----------------------|-----------------------|--------------------------------------|
| ACP + controller BA (*) | | 29470 | 29471 |
| Plate ACP | | 29363 | 29364 |
| Controller BA | | 29376 | 29377 |
| ACP + controller UA (*) | 29448 | 29472 | 29473 |
| Plate ACP | 29447 | 29363 | 29364 |
| Controller UA | 29446 | 29378 | 29380 |
| ACP + controller UA150 (*) (communication option) | | 29474 | 29475 |
| Plate ACP | | 29363 | 29364 |
| Controller UA150 | | 29379 | 29381 |

(*) *The supply voltages of the BA/UA controller, ACP plate, IVE unit and circuit breaker operating mechanism must be identical whatever the type of source-changeover system.*

Source-changeover systems for 2 or 3 devices

Masterpact NW circuit breakers
and switch-disconnectors

Communication module

DB40392.eps

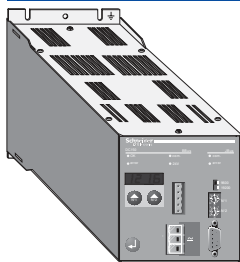

DC150 data concentrator
110-240 V AC / 115-125 V DC

50823

Interlocking for source-changeover systems for 3 devices

Interlocking of 3 devices using cables

Choose 3 adaptation fixtures (1 complete set with 3 adaptation fixtures + cables)

3 sources, only 1 device closed, fixed or drawout devices

48610

2 sources, 1 coupling, fixed or drawout devices

48609

2 normal, 1 replacement source, fixed or drawout devices

48608

Source-changeover systems for 2 devices

Compact INS40 to INS630

Switch-disconnectors

To indicate your choices, check the applicable square boxes and enter the appropriate information in the rectangles .

Mechanical interlocking of two INS40 to INS630 devices

Devices with front rotary handles, mounted side by side

| | | | |
|-------------------------------|--|--------------------------|---|
| | Two devices with direct rotary handles | | |
| | INS250 | <input type="checkbox"/> | INS320/400/500/630 <input type="checkbox"/> |
| | Two devices with extended rotary handles | | |
| | INS40/63/80 | <input type="checkbox"/> | INS100/125/160 <input type="checkbox"/> |
| | INS250 | <input type="checkbox"/> | INS320/400/500/630 <input type="checkbox"/> |
| Downstream coupling accessory | INS250 | <input type="checkbox"/> | INS320/400/500/630 <input type="checkbox"/> |
| Long terminal shields | INS250 | <input type="checkbox"/> | INS320/400/500/630 <input type="checkbox"/> |

Complete source-changeover assembly

| | | | | |
|--|--------------|--------------------------|--------------|--------------------------|
| | INS250-100 A | <input type="checkbox"/> | INS250-160 A | <input type="checkbox"/> |
| | INS250-200 A | <input type="checkbox"/> | INS250-250 A | <input type="checkbox"/> |
| | INS320 | <input type="checkbox"/> | INS400 | <input type="checkbox"/> |
| | INS500 | <input type="checkbox"/> | INS630 | <input type="checkbox"/> |

Source-changeover systems for 2 devices

Compact INS40 to INS630 Switch-disconnectors

To indicate your choices, check the applicable square boxes and enter the appropriate information in the rectangles .

(one sheet per device, make copies if necessary)

Device identification:

Q 1 - NORMAL SOURCE

Q 2 - REPLACEMENT SOURCE

Switch-disconnector

| | | |
|-----------------|---------------------------|--------------------------|
| Compact type | INS40/63/80 | <input type="checkbox"/> |
| | INS100/125/160 | <input type="checkbox"/> |
| | INS250 | <input type="checkbox"/> |
| | INS320/400/500/630 | <input type="checkbox"/> |
| Rating | A | <input type="checkbox"/> |
| Number of poles | 3 or 4 | <input type="checkbox"/> |

Connections

| | | |
|---|--|--------------------------|
| Front connection | Standard | <input type="checkbox"/> |
| Rear connection | 2 short <input type="checkbox"/> 2 long <input type="checkbox"/> | <input type="checkbox"/> |
| INS40/80 connectors | Distribution 3x16° rigid/10° flexible | <input type="checkbox"/> |
| INS100/160 connectors | Snap-on ≤ 95° Distribution 4x25° rigid/16° flexible | <input type="checkbox"/> |
| INS250 connectors | Snap-on 1.5° to 95° (< 160 A) Snap-on 10° to 185° (< 250 A) Voltage tap connector for 185° connector | <input type="checkbox"/> |
| | Clips for connectors Set of 10 | <input type="checkbox"/> |
| | Distribution 6x1.5° to 35° rigid with interphase barriers | <input type="checkbox"/> |
| INS320/630 connectors | 1 cable 35° to 300° 2 cables 35° to 240° Voltage tap connector for 185° connector | <input type="checkbox"/> |
| Distribution blocks | Linery DX 4P 125 A <input type="checkbox"/> 160 A <input type="checkbox"/> 1P 160 A <input type="checkbox"/> Linery BS 160 A <input type="checkbox"/> 250 A <input type="checkbox"/> (multi stage) Linery DP 250 A <input type="checkbox"/> | <input type="checkbox"/> |
| Rt-angle extension | Set of 3 or 4 250 A <input type="checkbox"/> 630 A <input type="checkbox"/> | <input type="checkbox"/> |
| Straight extension | INS250 | <input type="checkbox"/> |
| Edgewise ext. | INS630 | <input type="checkbox"/> |
| Spreader | INS250 (45 mm) Front alignment base INS320/630 52.5 mm <input type="checkbox"/> 70 mm <input type="checkbox"/> One-piece INS250 <input type="checkbox"/> INS630 <input type="checkbox"/> | <input type="checkbox"/> |
| Cu cable lugs supplied with 2 or 3 inter-phase barriers | INS100/160 For 95° cable INS250 For 120° cable For 150° cable For 185° cable INS320/630 For 240° cable For 300° cable | <input type="checkbox"/> |
| Al cable lugs supplied with 2 or 3 inter-phase barriers | INS250 For 150° cable For 185° cable INS320/630 For 240° cable For 300° cable | <input type="checkbox"/> |
| Terminal shrouds | INS40/63/80 <input type="checkbox"/> INS100/125/160 <input type="checkbox"/> | <input type="checkbox"/> |
| Terminal shields | INS40/63/80 <input type="checkbox"/> INS100/125/160 <input type="checkbox"/> INS250 Long <input type="checkbox"/> INS320/630 Long <input type="checkbox"/> Long for 52.5 mm spreaders <input type="checkbox"/> | <input type="checkbox"/> |
| Interphase barriers | INS100/160 Set of 6 <input type="checkbox"/> INS250 Set of 6 <input type="checkbox"/> INS320/630 Set of 6 <input type="checkbox"/> | <input type="checkbox"/> |

Indication and measurements

| | | | |
|--|---------------|-------------|------------------------------------|
| 4P ammeter module | For INS250 | Rating | 100 A <input type="checkbox"/> |
| | | | 150 A <input type="checkbox"/> |
| | | | 250 A <input type="checkbox"/> |
| Adaptation kit required for direct handles | | | |
| 4P current-transformer module | For INS250 | Rating | 400 A <input type="checkbox"/> |
| | | | 600 A <input type="checkbox"/> |
| | | | 100 A <input type="checkbox"/> |
| Auxiliary contact | For INS40/160 | 1OF/CAF/CAO | Standard <input type="checkbox"/> |
| | | | Low level <input type="checkbox"/> |
| | | | For INS250/630 |
| | | | Standard <input type="checkbox"/> |
| | | | Low level <input type="checkbox"/> |

Rotary handles

| | | | |
|------------------------|----------------------------------|--------------------------------|--|
| Extended front handles | INS40 to INS160 | Black <input type="checkbox"/> | Red on yellow front <input type="checkbox"/> |
| | INS250 | Black <input type="checkbox"/> | Red on yellow front <input type="checkbox"/> |
| | INS320 to INS630 | Black <input type="checkbox"/> | Red on yellow front <input type="checkbox"/> |
| | For complete changeover assembly | | INS250 <input type="checkbox"/> |
| | | | INS320/630 <input type="checkbox"/> |

Locking of rotary handles

| | | |
|------------|---|--------------------------|
| Padlocking | 1 to 3 padlocks (in OFF position) | <input type="checkbox"/> |
| Keylocking | Keylock adapter (keylock not included) | <input type="checkbox"/> |
| | Keylocks Ronis 1351B.500 <input type="checkbox"/> Profalux KS5 B24 D4Z <input type="checkbox"/> | <input type="checkbox"/> |

Installation accessories

| | |
|------------------------|---|
| Front-panel escutcheon | For switch-disconnectors <input type="checkbox"/> |
| | For ammeter module, IP40 <input type="checkbox"/> |

Source-changeover systems for 2 devices

Compact NSX100 to NSX630 / Circuit breakers and switch-disconnectors

To indicate your choices, check the applicable square boxes and enter the appropriate information in the rectangles .

Diagram for two Compact NSX devices

| | | |
|--|----------------|--------------------------|
| Without automatic control, without emergency off auxiliaries | (no. 51201177) | <input type="checkbox"/> |
| Without automatic control, with emergency off by MN | (no. 51201178) | <input type="checkbox"/> |
| Without automatic control, with emergency off by MX | (no. 51201179) | <input type="checkbox"/> |

Mechanical interlocking of two NSX100 to NSX630 devices

(fixed, plug-in or withdrawable)

Manually operated devices, mounted side by side:

| | |
|---------------------------------|--------------------------|
| Two devices with toggles | <input type="checkbox"/> |
| Two devices with rotary handles | <input type="checkbox"/> |

Mechanical and electrical interlocking of two NSX100 to NSX630 devices

(fixed or plug-in)

Electrically operated devices, mounted side by side:

Select 1 base plate + IVE unit, the 4 auxiliary contacts and the options / accessories

| | | | |
|-------------------------------|--|--------------------------|--------------------------|
| Base plate + IVE unit | Identical voltages: | 48 to 415 V AC 50/60 Hz | <input type="checkbox"/> |
| | 24 to 250 V DC | 440/480 V AC 60 Hz | <input type="checkbox"/> |
| | "Normal" NSX100/250 | "Replacement" NSX100/250 | <input type="checkbox"/> |
| | "Normal" NSX400/630 | "Replacement" NSX400/630 | <input type="checkbox"/> |
| | "Normal" NSX400/630 | "Replacement" NSX100/250 | <input type="checkbox"/> |
| | Adapter kit for NSX400/630 with NSX100/250 (plug-in) | | <input type="checkbox"/> |
| Auxiliary contacts | 2 OF + 2 SDE (mandatory) | Quantity | 4 |
| Options | Long rear connections | Plug-in base | <input type="checkbox"/> |
| Downstream coupling accessory | 3P | NSX100/250 | <input type="checkbox"/> |
| | 4P | NSX400/630 | <input type="checkbox"/> |
| Prefabricated wiring | Between device and IVE | Quantity | <input type="checkbox"/> |

Automatic-control option

| | | |
|--|------------------------|--------------------------|
| Power supply 220/240 V - 50/60 Hz: | ACP + BA controller | <input type="checkbox"/> |
| | ACP + UA controller | <input type="checkbox"/> |
| | ACP + UA150 controller | <input type="checkbox"/> |
| Power supply 380/415 V - 50/60 Hz and 440 V - 60 Hz: | ACP + BA controller | <input type="checkbox"/> |
| | ACP + UA controller | <input type="checkbox"/> |
| | ACP + UA150 controller | <input type="checkbox"/> |

Source-changeover systems for 2 devices

Compact NSX100 to NSX630 / Circuit breakers and switch-disconnectors

(One sheet per device, make copies if necessary)

Name of customer: _____
Address for delivery: _____
Requested delivery date: _____
Customer order no.: _____

To indicate your choices, check the applicable square boxes
and enter the appropriate information in the rectangles

Q 1 - NORMAL SOURCE

Q 2 - REPLACEMENT SOURCE

| Circuit breaker or switch disconnecter | | | | | | | | | | | | | | | | | | | | | | | |
|---|---|---|---|---|--|--|---|---|---|---|---|---|---|---|---|---|---|---|---|---|---|---------------------------------------|--|
| Compact type | NSX100/160/250 <input type="checkbox"/> NSX400/630 <input type="checkbox"/> | | | | | | | | | | | | | | | | | | | | | | |
| Rating | A <input type="checkbox"/> | | | | | | | | | | | | | | | | | | | | | | |
| Circuit breaker | B, F, N, H, S, L <input type="checkbox"/> | | | | | | | | | | | | | | | | | | | | | | |
| Switch-discon. | NA <input type="checkbox"/> | | | | | | | | | | | | | | | | | | | | | | |
| No. of poles | 2, 3 or 4 <input type="checkbox"/> | | | | | | | | | | | | | | | | | | | | | | |
| No. of poles protected | 2d, 3d or 4d <input type="checkbox"/> | | | | | | | | | | | | | | | | | | | | | | |
| Fixed device | Front connections <input type="checkbox"/> | | | | | | | | | | | | | | | | | | | | | | |
| Plug-in/withdr. | Plug-in <input type="checkbox"/> Withdrawable <input type="checkbox"/> | | | | | | | | | | | | | | | | | | | | | | |
| Earth-leakage protection | ME, MH, MB <input type="checkbox"/> | | | | | | | | | | | | | | | | | | | | | | |
| Vigi module | Voltage <input type="checkbox"/> 4P option on 3P NSX <input type="checkbox"/> | | | | | | | | | | | | | | | | | | | | | | |
| Trip unit | | | | | | | | | | | | | | | | | | | | | | | |
| Thermal-mag. | TMD rating (16 ... 250 A) <input type="checkbox"/> TMG rating (16 ... 63 A) <input type="checkbox"/> MA rating (2.5 ... 220 A) <input type="checkbox"/> | | | | | | | | | | | | | | | | | | | | | | |
| Electronic | <table border="0"> <tr> <td>Micrologic 2.2 <input type="checkbox"/></td> <td>Micrologic 2.3 <input type="checkbox"/></td> </tr> <tr> <td>Micrologic 2.2 G <input type="checkbox"/></td> <td>Micrologic 2.3 AB <input type="checkbox"/></td> </tr> <tr> <td>Micrologic 2.2 AB <input type="checkbox"/></td> <td>Micrologic 5.3 A <input type="checkbox"/></td> </tr> <tr> <td>Micrologic 5.2 A <input type="checkbox"/></td> <td>Micrologic 5.3 E <input type="checkbox"/></td> </tr> <tr> <td>Micrologic 5.2 E <input type="checkbox"/></td> <td>Micrologic 5.3 A-Z <input type="checkbox"/></td> </tr> <tr> <td>Micrologic 5.2 A-Z <input type="checkbox"/></td> <td>Micrologic 6.3 A <input type="checkbox"/></td> </tr> <tr> <td>Micrologic 6.2 A <input type="checkbox"/></td> <td>Micrologic 6.3 E <input type="checkbox"/></td> </tr> <tr> <td>Micrologic 6.2 E <input type="checkbox"/></td> <td>Micrologic 1.3 M <input type="checkbox"/></td> </tr> <tr> <td>Micrologic 2.2 M <input type="checkbox"/></td> <td>Micrologic 2.3 M <input type="checkbox"/></td> </tr> <tr> <td>Micrologic 6.2 E-M <input type="checkbox"/></td> <td>Micrologic 6.3 E-M <input type="checkbox"/></td> </tr> <tr> <td>SDTAM module <input type="checkbox"/></td> <td></td> </tr> </table> | Micrologic 2.2 <input type="checkbox"/> | Micrologic 2.3 <input type="checkbox"/> | Micrologic 2.2 G <input type="checkbox"/> | Micrologic 2.3 AB <input type="checkbox"/> | Micrologic 2.2 AB <input type="checkbox"/> | Micrologic 5.3 A <input type="checkbox"/> | Micrologic 5.2 A <input type="checkbox"/> | Micrologic 5.3 E <input type="checkbox"/> | Micrologic 5.2 E <input type="checkbox"/> | Micrologic 5.3 A-Z <input type="checkbox"/> | Micrologic 5.2 A-Z <input type="checkbox"/> | Micrologic 6.3 A <input type="checkbox"/> | Micrologic 6.2 A <input type="checkbox"/> | Micrologic 6.3 E <input type="checkbox"/> | Micrologic 6.2 E <input type="checkbox"/> | Micrologic 1.3 M <input type="checkbox"/> | Micrologic 2.2 M <input type="checkbox"/> | Micrologic 2.3 M <input type="checkbox"/> | Micrologic 6.2 E-M <input type="checkbox"/> | Micrologic 6.3 E-M <input type="checkbox"/> | SDTAM module <input type="checkbox"/> | |
| Micrologic 2.2 <input type="checkbox"/> | Micrologic 2.3 <input type="checkbox"/> | | | | | | | | | | | | | | | | | | | | | | |
| Micrologic 2.2 G <input type="checkbox"/> | Micrologic 2.3 AB <input type="checkbox"/> | | | | | | | | | | | | | | | | | | | | | | |
| Micrologic 2.2 AB <input type="checkbox"/> | Micrologic 5.3 A <input type="checkbox"/> | | | | | | | | | | | | | | | | | | | | | | |
| Micrologic 5.2 A <input type="checkbox"/> | Micrologic 5.3 E <input type="checkbox"/> | | | | | | | | | | | | | | | | | | | | | | |
| Micrologic 5.2 E <input type="checkbox"/> | Micrologic 5.3 A-Z <input type="checkbox"/> | | | | | | | | | | | | | | | | | | | | | | |
| Micrologic 5.2 A-Z <input type="checkbox"/> | Micrologic 6.3 A <input type="checkbox"/> | | | | | | | | | | | | | | | | | | | | | | |
| Micrologic 6.2 A <input type="checkbox"/> | Micrologic 6.3 E <input type="checkbox"/> | | | | | | | | | | | | | | | | | | | | | | |
| Micrologic 6.2 E <input type="checkbox"/> | Micrologic 1.3 M <input type="checkbox"/> | | | | | | | | | | | | | | | | | | | | | | |
| Micrologic 2.2 M <input type="checkbox"/> | Micrologic 2.3 M <input type="checkbox"/> | | | | | | | | | | | | | | | | | | | | | | |
| Micrologic 6.2 E-M <input type="checkbox"/> | Micrologic 6.3 E-M <input type="checkbox"/> | | | | | | | | | | | | | | | | | | | | | | |
| SDTAM module <input type="checkbox"/> | | | | | | | | | | | | | | | | | | | | | | | |
| External neutral CT | <input type="checkbox"/> | | | | | | | | | | | | | | | | | | | | | | |
| 24 V DC power supply connector | <input type="checkbox"/> | | | | | | | | | | | | | | | | | | | | | | |
| ZSI wiring accessory for NS630b NW/NT | <input type="checkbox"/> | | | | | | | | | | | | | | | | | | | | | | |
| External power supply module | 24-30 V DC <input type="checkbox"/> 48-60 V DC <input type="checkbox"/> 100-125 V AC <input type="checkbox"/> 110-130 V AC <input type="checkbox"/> 24 V DC <input type="checkbox"/> 200-240 V AC <input type="checkbox"/> 380-415 V AC <input type="checkbox"/> | | | | | | | | | | | | | | | | | | | | | | |
| Battery module | <input type="checkbox"/> | | | | | | | | | | | | | | | | | | | | | | |
| Connection | | | | | | | | | | | | | | | | | | | | | | | |
| Rear-connection kit | Short <input type="checkbox"/> Long <input type="checkbox"/> Mixed <input type="checkbox"/> | | | | | | | | | | | | | | | | | | | | | | |
| NSX100/250 connectors | Snap-on 1.5 ^o to 95 ^o (< 160 A) <input type="checkbox"/> Snap-on 25 ^o to 95 ^o (< 250 A) <input type="checkbox"/> Snap-on 120 ^o to 185 ^o (< 250 A) <input type="checkbox"/> Distribution 6 x 1.5 ^o to 35 ^o <input type="checkbox"/> Aluminium 2 cables 50 ^o to 120 ^o <input type="checkbox"/> | | | | | | | | | | | | | | | | | | | | | | |
| NSX400/630 connectors | 1 cable 35 ^o to 300 ^o <input type="checkbox"/> 2 cables 35 ^o to 240 ^o <input type="checkbox"/> | | | | | | | | | | | | | | | | | | | | | | |
| Right-angle terminal extensions | <input type="checkbox"/> | | | | | | | | | | | | | | | | | | | | | | |
| Straight extensions | NSX100/250 <input type="checkbox"/> | | | | | | | | | | | | | | | | | | | | | | |
| Edgewise extensions | 45° term. ext. <input type="checkbox"/> Dbl.-L term. ext. <input type="checkbox"/> | | | | | | | | | | | | | | | | | | | | | | |
| Spreader | NSX100/250 (one piece) <input type="checkbox"/> (45 mm) <input type="checkbox"/> NSX400/630 (52.5 mm) <input type="checkbox"/> (70 mm) <input type="checkbox"/> | | | | | | | | | | | | | | | | | | | | | | |
| Cu cable lugs | NSX100/250 120 ^o <input type="checkbox"/> 150 ^o <input type="checkbox"/> 185 ^o <input type="checkbox"/> NSX400/630 240 ^o <input type="checkbox"/> 300 ^o <input type="checkbox"/> | | | | | | | | | | | | | | | | | | | | | | |
| Al cable lugs | NSX100/250 150 ^o <input type="checkbox"/> 185 ^o <input type="checkbox"/> NSX400/630 240 ^o <input type="checkbox"/> 300 ^o <input type="checkbox"/> | | | | | | | | | | | | | | | | | | | | | | |
| V mesrt Input for connector | For lugs NSX100/250 ≤ 185 ^o <input type="checkbox"/> For lugs NSX400/630 <input type="checkbox"/> | | | | | | | | | | | | | | | | | | | | | | |
| Terminal shields | NSX100/250 <input type="checkbox"/> Long <input type="checkbox"/> NSX400/630 <input type="checkbox"/> Long <input type="checkbox"/> Long for 52.5 mm spreaders <input type="checkbox"/> | | | | | | | | | | | | | | | | | | | | | | |
| Interphase barriers | Set of 6 <input type="checkbox"/> | | | | | | | | | | | | | | | | | | | | | | |
| 2 insulating scrn. | NSX100/250 <input type="checkbox"/> NSX400/630 70 pitch <input type="checkbox"/> | | | | | | | | | | | | | | | | | | | | | | |
| Test tool | | | | | | | | | | | | | | | | | | | | | | | |
| Pocket battery for Micrologic | <input type="checkbox"/> | | | | | | | | | | | | | | | | | | | | | | |
| Maintenance case | <input type="checkbox"/> | | | | | | | | | | | | | | | | | | | | | | |
| USB maintenance interface | <input type="checkbox"/> | | | | | | | | | | | | | | | | | | | | | | |
| Power supply 110-240 V AC | <input type="checkbox"/> | | | | | | | | | | | | | | | | | | | | | | |
| Spare Micrologic cord | <input type="checkbox"/> | | | | | | | | | | | | | | | | | | | | | | |

| Indication and measurement | |
|---|--|
| Ammeter module | Standard <input type="checkbox"/> 3P <input type="checkbox"/> 4P <input type="checkbox"/> I max <input type="checkbox"/> 3P <input type="checkbox"/> |
| Current-transformer module | 3P <input type="checkbox"/> 4P <input type="checkbox"/> |
| Current-transformer module + TCU | 3P <input type="checkbox"/> 4P <input type="checkbox"/> |
| Insulation-monitoring module | 3P <input type="checkbox"/> 4P <input type="checkbox"/> |
| Voltage-presence indicator | <input type="checkbox"/> |
| Auxiliary contact | OF <input type="checkbox"/> SD <input type="checkbox"/> SDE <input type="checkbox"/> SDV <input type="checkbox"/> Standard <input type="checkbox"/> OF <input type="checkbox"/> SD <input type="checkbox"/> SDE <input type="checkbox"/> SDV <input type="checkbox"/> Low level <input type="checkbox"/> |
| SDE adapter (TM, MA or Micrologic 2 trip units) | <input type="checkbox"/> |
| SDX module | <input type="checkbox"/> |
| Remote operation | |
| Electrical operation | Motor mechanism AC <input type="checkbox"/> DC <input type="checkbox"/> V <input type="checkbox"/> |
| Voltage releases | Instantaneous MX AC <input type="checkbox"/> DC <input type="checkbox"/> V <input type="checkbox"/> Instantaneous MN AC <input type="checkbox"/> DC <input type="checkbox"/> V <input type="checkbox"/> Fixed time delay MN AC <input type="checkbox"/> DC <input type="checkbox"/> V <input type="checkbox"/> Adjust. time delay MN AC <input type="checkbox"/> DC <input type="checkbox"/> V <input type="checkbox"/> |
| Rotary handles | |
| Direct | Black <input type="checkbox"/> Red and yellow front <input type="checkbox"/> MCC conversion access. <input type="checkbox"/> CNOMO conversion access. <input type="checkbox"/> |
| Extended | Black <input type="checkbox"/> Red and yellow front <input type="checkbox"/> Telescopic handle for withdrawable device <input type="checkbox"/> |
| Indication auxiliary | 1 early-break switch <input type="checkbox"/> 2 early-make switches <input type="checkbox"/> |
| Locking | |
| Toggle (1 to 3 padlocks) | Removable <input type="checkbox"/> Fixed <input type="checkbox"/> |
| Rotary handle | Keylock adapter (keylock not included) <input type="checkbox"/> Keylocks Ronis 1351B.500 <input type="checkbox"/> Profalux KS5 B24 D4Z <input type="checkbox"/> |
| Motor mechanism | Keylock adapter + keylock Ronis (special) <input type="checkbox"/> NSX100/250 <input type="checkbox"/> Keylock adapter (keylock not included) <input type="checkbox"/> NSX400/630 <input type="checkbox"/> Keylocks Ronis 1351B.500 <input type="checkbox"/> Profalux KS5 B24 D4Z <input type="checkbox"/> |
| Interlocking | |
| Mechanical | Toggle operated <input type="checkbox"/> Rotary Handle <input type="checkbox"/> |
| By key (2 keylocks, 1 key) for rotary handle | Locking kit without locks <input type="checkbox"/> Keylocks Ronis 1351B.500 <input type="checkbox"/> Profalux KS5 B24 D4Z <input type="checkbox"/> |
| Installation accessories | |
| IP30 escutcheon for all types (toggle/rotary handle/motor mechanism) | <input type="checkbox"/> |
| IP30 escutcheon (with access to toggle + trip unit) | <input type="checkbox"/> |
| IP30 escutcheon for Vigi module | <input type="checkbox"/> |
| IP40 escutcheon for all types (toggle/rotary handle/motor mechanism) | <input type="checkbox"/> |
| IP40 escutcheon for Vigi module | <input type="checkbox"/> |
| IP40 escutcheon for Vigi or ammeter module | <input type="checkbox"/> |
| Toggle cover | <input type="checkbox"/> |
| Sealing accessories | <input type="checkbox"/> |
| DIN rail adapter | <input type="checkbox"/> |
| 3P 60 mm busbar adapter | <input type="checkbox"/> |
| Plug-in / withdrawable configuration accessories | |
| Auxiliary connections | 1 automatic connector fixed part with 9 wires (for base) <input type="checkbox"/> 1 automatic connector moving part with 9 wires (for circuit breaker) <input type="checkbox"/> 1 sup. for 3 auto. conn. moving parts <input type="checkbox"/> 1 sup. for 2 auto. conn. <input type="checkbox"/> 9-wire manual auxiliary connector (fixed + moving) <input type="checkbox"/> |
| Plug-in base accessories | Long insulated terminals <input type="checkbox"/> Set of 2 <input type="checkbox"/> 2 IP4 shutters for base <input type="checkbox"/> |
| Chassis accessories | Escutcheon collar <input type="checkbox"/> Toggle <input type="checkbox"/> Vigi <input type="checkbox"/> Locking kit (keylock not included) <input type="checkbox"/> 2 carriage switches (conn./disconnected position indication) <input type="checkbox"/> |
| Parts or plug-in | Plug-in base FC/RC 2P <input type="checkbox"/> 3P <input type="checkbox"/> 4P <input type="checkbox"/> |
| Withdrawable kits | Set of two power connections <input type="checkbox"/> Standard <input type="checkbox"/> Vigi <input type="checkbox"/> Safety trip for advanced opening <input type="checkbox"/> For 3P/4P chassis <input type="checkbox"/> Moving part <input type="checkbox"/> Fixed part <input type="checkbox"/> |
| Adaptater for plug-in base (for terminal shield or interphase barriers) | <input type="checkbox"/> |
| Communication | |
| | NSX Cord L = 0.35 m <input type="checkbox"/> NSX Cord L = 1.3 m <input type="checkbox"/> NSX Cord U > 480 V AC L = 0.35 m <input type="checkbox"/> NSX Cord L = 3 m <input type="checkbox"/> |
| BSCM (NSX400/630) | <input type="checkbox"/> |
| Communicating motor mechanism 220-240 V | <input type="checkbox"/> |
| Switchboard front display module FDM121 | <input type="checkbox"/> |
| FDM mounting accessory | <input type="checkbox"/> |
| Modbus interface | <input type="checkbox"/> |
| Stacking accessory | <input type="checkbox"/> |
| ULP line termination | <input type="checkbox"/> |
| RJ45 connectors female/female | Wire length RJ45 L = 0.3 m <input type="checkbox"/> Wire length RJ45 L = 0.6 m <input type="checkbox"/> Wire length RJ45 L = 1 m <input type="checkbox"/> Wire length RJ45 L = 2 m <input type="checkbox"/> Wire length RJ45 L = 3 m <input type="checkbox"/> Wire length RJ45 L = 5 m <input type="checkbox"/> |

Source-changeover systems for 2 devices

Compact NS630b to NS1600 / Circuit breakers and switch-disconnectors

To indicate your choices, check the applicable square boxes and enter the appropriate information in the rectangles .

Diagram for two Compact NS devices

Electrical interlocking with lockout after fault:

| | | |
|--|----------------|--------------------------|
| Permanent replacement source (with IVE unit) | (no. 51201183) | <input type="checkbox"/> |
| With emergency off by MX (with IVE unit) | (no. 51201184) | <input type="checkbox"/> |
| With emergency off by MN (with IVE unit) | (no. 51201185) | <input type="checkbox"/> |

Interlocking using connecting rods between two NS630b to NS1600 devices

Manually operated devices installed side-by-side:

For two fixed NS devices with extended rotary handles

Electrically operated devices installed one above the other:

Select a complete set including two adaptation fixtures and the connecting rods

| | | |
|-------------------|---------------------------|--------------------------|
| Complete set for: | 2 fixed NS devices | <input type="checkbox"/> |
| | 2 withdrawable NS devices | <input type="checkbox"/> |

Interlocking using cables between two NS630b to NS1600 devices

Electrically operated devices installed one above the other or side-by-side:

Select a complete set including two adaptation fixtures and the cables

| | | |
|-------------------|--|--------------------------|
| Complete set for: | 2 fixed NS devices | <input type="checkbox"/> |
| | 2 withdrawable NS devices | <input type="checkbox"/> |
| | 1 fixed NS device + 1 withdrawable NS device | <input type="checkbox"/> |

Electrical interlocking between two NS630b to NS1600 devices

1 IVE unit 48/415 V - 50/60 Hz and 440 V - 60 Hz

1 wiring kit for connection between 2 fixed / withdrawable devices to the IVE unit

Automatic-control option

| | | |
|--|------------------------|--------------------------|
| Power supply 110 V - 50/60 Hz: | ACP + BA controller | <input type="checkbox"/> |
| | ACP + UA controller | <input type="checkbox"/> |
| | ACP + UA150 controller | <input type="checkbox"/> |
| Power supply 220/240 V - 50/60 Hz: | ACP + BA controller | <input type="checkbox"/> |
| | ACP + UA controller | <input type="checkbox"/> |
| | ACP + UA150 controller | <input type="checkbox"/> |
| Power supply 380/415 V - 50/60 Hz and 440 V - 60 Hz: | ACP + BA controller | <input type="checkbox"/> |
| | ACP + UA controller | <input type="checkbox"/> |
| | ACP + UA150 controller | <input type="checkbox"/> |

Source-changeover systems for 2 devices

Compact NS630b to NS1600 / Circuit breakers and switch-disconnectors

(One sheet per device, make copies if necessary)

Name of customer: _____
Address for delivery: _____
Requested delivery date: _____
Customer order no.: _____

To indicate your choices, check the applicable square boxes and enter the appropriate information in the rectangles

Device identification:

Q 1 - NORMAL SOURCE

Q 2 - REPLACEMENT SOURCE

Circuit breaker or switch disconnecter

| | | | |
|---------------------|---|--------------------------|--|
| Compact type | NS630b to NS1600 | | |
| Rating | A | | |
| Circuit breaker | N, H, L | | |
| Switch-disconnector | NA | | |
| Number of poles | 3 or 4 | | |
| Device | Fixed | <input type="checkbox"/> | |
| | Withdr. with chassis | <input type="checkbox"/> | |
| | Withdr. without chassis (moving part only) | <input type="checkbox"/> | |

Chassis alone without connections

Micrologic control unit

| | | | | | | |
|--|---------------------------|--------------------------|-----|--------------------------|--------------------------|------------------------------|
| Basic protection | 2.0 | <input type="checkbox"/> | 5.0 | <input type="checkbox"/> | 6.0 | <input type="checkbox"/> |
| A - ammeter | 2.0 | <input type="checkbox"/> | 5.0 | <input type="checkbox"/> | 6.0 | 7.0 <input type="checkbox"/> |
| E - energy meter | 2.0 | <input type="checkbox"/> | 5.0 | <input type="checkbox"/> | 6.0 | <input type="checkbox"/> |
| P - power meter | | <input type="checkbox"/> | 5.0 | <input type="checkbox"/> | 6.0 | 7.0 <input type="checkbox"/> |
| AD - external power-supply module | | | | V | <input type="checkbox"/> | |
| TCE - external sensor (CT) for neutral protection | | | | | <input type="checkbox"/> | |
| Rectangular sensor | 280 x 115 mm | | | | <input type="checkbox"/> | |
| TCW - external sensor for SGR protection | | | | | <input type="checkbox"/> | |
| LR - long-time rating plug | Standard 0.4 to 1 Ir | | | | <input type="checkbox"/> | |
| | Low setting 0.4 to 0.8 Ir | | | | <input type="checkbox"/> | |
| | High setting 0.8 to 1 Ir | | | | <input type="checkbox"/> | |
| | LT OFF | | | | <input type="checkbox"/> | |

Communication

| | | | | |
|-------------------------------|--------------------|--------------------------|--------------------------|--------------------------|
| Eco COM module Modbus | Device | <input type="checkbox"/> | Chassis | <input type="checkbox"/> |
| Front Display Module (FDM121) | Mounting accessory | | <input type="checkbox"/> | |
| Breaker ULP cord | L = 0.35 m | <input type="checkbox"/> | | |
| | L = 1.3 m | <input type="checkbox"/> | | |
| | L = 3 m | <input type="checkbox"/> | | |

Connections

| | | | | |
|--|------------------------|--------------------------|--------|--------------------------|
| Horizontal rear connections | Top | <input type="checkbox"/> | Bottom | <input type="checkbox"/> |
| Vertical rear connections | Top | <input type="checkbox"/> | Bottom | <input type="checkbox"/> |
| Front connections | Top | <input type="checkbox"/> | Bottom | <input type="checkbox"/> |
| 4x240 ³ bare cable connectors | NS - FC fixed | | | <input type="checkbox"/> |
| + shields | | | | |
| Long connection shields | NS - FC fixed | | | <input type="checkbox"/> |
| Vertical-connection adapters | NS - FC fixed, withdr. | | | <input type="checkbox"/> |
| Cable-lug adapters | NS - FC fixed, withdr. | | | <input type="checkbox"/> |
| Arc chute screen | NS - FC fixed | | | <input type="checkbox"/> |
| Interphase barriers | NS - FC fixed, withdr. | | | <input type="checkbox"/> |
| Spreaders | NS - FC fixed, withdr. | | | <input type="checkbox"/> |
| VO - safety shutters on chassis | NS - FC fixed | | | <input type="checkbox"/> |

Indication contacts

| | | | | |
|---|----------------------------|------------------------------|----------------------------|------------------------------|
| SD trip indication (maximum 1) | 6 A-240 V AC | <input type="checkbox"/> | Low level | <input type="checkbox"/> |
| SDE fault-trip indication (maximum 1) (SDE integrated in electrically operated devices) | 6 A-240 V AC | <input type="checkbox"/> | Low level | <input type="checkbox"/> |
| OF ON/OFF indication contacts (maximum 3) | 6 A-240 V AC | qty <input type="checkbox"/> | Low level | qty <input type="checkbox"/> |
| Carriage switches (possible combinations: 3 CE, 2 CD, 1 CT) | | | | |
| CE - "connected" position | 6 A-240 V AC | qty <input type="checkbox"/> | Low level | qty <input type="checkbox"/> |
| CD - "disconnected" position | 6 A-240 V AC | qty <input type="checkbox"/> | Low level | qty <input type="checkbox"/> |
| CT - "test" position | 6 A-240 V AC | qty <input type="checkbox"/> | Low level | qty <input type="checkbox"/> |
| Auxiliary terminals for chassis alone | Jumpers (set of 10) | | <input type="checkbox"/> | |
| | 3-wire terminal (30 parts) | <input type="checkbox"/> | 6-wire terminal (10 parts) | <input type="checkbox"/> |

Remote operation

| | | | | |
|----------------------|---------------|-------------------------------------|---|----------------------------|
| Electrical operation | Standard | <input type="checkbox"/> | Communicating | <input type="checkbox"/> |
| | Power supply | AC <input type="checkbox"/> | DC <input type="checkbox"/> | V <input type="checkbox"/> |
| Voltage releases | MX | AC <input type="checkbox"/> | DC <input type="checkbox"/> | V <input type="checkbox"/> |
| | MN | AC <input type="checkbox"/> | DC <input type="checkbox"/> | V <input type="checkbox"/> |
| | MN delay unit | Adjustable <input type="checkbox"/> | Non-adjustable <input type="checkbox"/> | |

Rotary handles for fixed and withdrawable device

| | | | | |
|----------------------|--|--------------------------|--------------------------|--------------------------|
| Direct | Black | <input type="checkbox"/> | Red on yellow front | <input type="checkbox"/> |
| | | | CNOMO conversion access. | <input type="checkbox"/> |
| Extended | Black | <input type="checkbox"/> | Red on yellow front | <input type="checkbox"/> |
| | Telescopic handle for withdrawable device <input type="checkbox"/> | | | |
| Indication auxiliary | 6 A-240 V AC | | 2 early-make switches | <input type="checkbox"/> |
| | | | 2 early-break switches | <input type="checkbox"/> |

Locking

| | | | | |
|-----------------------------------|--|-----------------------------------|--------------------------------|--------------------------|
| Toggle (1 to 3 padlocks) | Removable system | <input type="checkbox"/> | Fixed system | <input type="checkbox"/> |
| Rotary handle using a keylock | OFF position | <input type="checkbox"/> | ON and OFF positions | <input type="checkbox"/> |
| | Ronis 1351B.500 | <input type="checkbox"/> | Profalux KS5 B24 D4Z | <input type="checkbox"/> |
| | Keylock kit (without keylock) | | | <input type="checkbox"/> |
| For electrically operated devices | VBP - ON/OFF pushbutton locking | | | <input type="checkbox"/> |
| | OFF position locking: | | | |
| | VCPO - by padlocks | | | <input type="checkbox"/> |
| | VSPO - by keylocks | | | |
| | Keylock kit (w/o keylock) | Profalux <input type="checkbox"/> | Ronis <input type="checkbox"/> | |
| | 1 keylock | Profalux <input type="checkbox"/> | Ronis <input type="checkbox"/> | |
| | 2 identical keylocks, 1 key | Profalux <input type="checkbox"/> | Ronis <input type="checkbox"/> | |

Chassis locking in "disconnected" position:

| | | | |
|---------------------------|--|-----------------------------------|----------------------------------|
| VSPD - by keylocks | Keylock kit (w/o keylock) | Profalux <input type="checkbox"/> | Ronis <input type="checkbox"/> |
| | | Kirk <input type="checkbox"/> | Castell <input type="checkbox"/> |
| | 1 keylock | Profalux <input type="checkbox"/> | Ronis <input type="checkbox"/> |
| | 2 identical keylocks, 1 key | Profalux <input type="checkbox"/> | Ronis <input type="checkbox"/> |
| | 2 keylocks, different keys | Profalux <input type="checkbox"/> | Ronis <input type="checkbox"/> |
| | Optional connected/disconnected/test position locking <input type="checkbox"/> | | |

| | | |
|------------------------------|-------------------------------|--------------------------|
| VPEC - door interlock | On right-hand side of chassis | <input type="checkbox"/> |
| | On left-hand side of chassis | <input type="checkbox"/> |

| | |
|----------------------------------|--------------------------|
| VPOC - racking interlock | <input type="checkbox"/> |
| VDC - mismatch protection | <input type="checkbox"/> |

Accessories

| | |
|--|---|
| CDM - mechanical operation counter | <input type="checkbox"/> |
| CDP - escutcheon | <input type="checkbox"/> |
| CP - transparent cover for escutcheon | <input type="checkbox"/> |
| OP - blanking plate for escutcheon | <input type="checkbox"/> |
| Mounting brackets for fixed NS | For mounting on horizontal plane <input type="checkbox"/> |
| Test kits | Mini test kit <input type="checkbox"/> Portable test kit <input type="checkbox"/> |

Source-changeover systems for 2 devices

Masterpact NT or NW / Circuit breakers and switch-disconnectors

To indicate your choices, check the applicable square boxes and enter the appropriate information in the rectangles .

Diagram for 2 Masterpact NT/NW devices

Electrical interlocking with lockout after fault:

| | | |
|--|----------------|--------------------------|
| Permanent replacement source (with IVE unit) | (no. 51201142) | <input type="checkbox"/> |
| With emergency off by MX (with IVE unit) | (no. 51201143) | <input type="checkbox"/> |
| With emergency off by MN (with IVE unit) | (no. 51201144) | <input type="checkbox"/> |

Automatic control with lockout after fault:

| | | |
|--|----------------|--------------------------|
| Permanent replacement source (with IVE unit) | (no. 51156904) | <input type="checkbox"/> |
| Engine generator set (with IVE unit) | (no. 51156905) | <input type="checkbox"/> |
| BA/UA controller (with IVE unit) | (no. 51156903) | <input type="checkbox"/> |

Interlocking using connecting rods (NT/NW devices one above the other)

Select a complete set including two adaptation fixtures and the connecting rods

| | | | | |
|-------------------|---|--------------------------|--------------------|--------------------------|
| Complete set for: | 2 drawout NT devices | <input type="checkbox"/> | 2 fixed NT devices | <input type="checkbox"/> |
| | 2 drawout NW devices | <input type="checkbox"/> | 2 fixed NW devices | <input type="checkbox"/> |
| | 1 fixed NT device + 1 fixed NW device | <input type="checkbox"/> | | <input type="checkbox"/> |
| | 1 drawout NT device + 1 drawout NW device | <input type="checkbox"/> | | <input type="checkbox"/> |

Interlocking using cables (NT/NW devices one above the other or side-by-side)

Select two adaptation fixtures (one for each device) and a set of two cables

| | | | |
|--|-------------------------------------|-----|--------------------------|
| Adaptation fixture for: | 1 fixed NT device | qty | <input type="text"/> |
| (NT/NW fixed and drawout devices may be mixed) | 1 drawout NT device | qty | <input type="text"/> |
| | 1 fixed NW device | qty | <input type="text"/> |
| | 1 drawout NW device | qty | <input type="text"/> |
| | 1 set of 2 cables (for two devices) | | <input type="checkbox"/> |

Electrical interlocking 2 Masterpact NT/NW devices

| | |
|--|--------------------------|
| 1 IVE unit 48/415 V - 50/60 Hz and 440 V - 60 Hz | <input type="checkbox"/> |
| 1 wiring kit for connection between 2 fixed / withdrawable devices to the IVE unit | <input type="checkbox"/> |

Automatic-control option

| | | |
|--|------------------------|--------------------------|
| Power supply 220/240 V - 50/60 Hz: | ACP + BA controller | <input type="checkbox"/> |
| | ACP + UA controller | <input type="checkbox"/> |
| | ACP + UA150 controller | <input type="checkbox"/> |
| Power supply 380/415 V - 50/60 Hz and 440 V - 60 Hz: | ACP + BA controller | <input type="checkbox"/> |
| | ACP + UA controller | <input type="checkbox"/> |
| | ACP + UA150 controller | <input type="checkbox"/> |

Source-changeover systems for 2 devices

Masterpact NT or NW / Circuit breakers and switch-disconnectors

(One sheet per device, make copies if necessary)

Name of customer: _____
Address for delivery: _____
Requested delivery date: _____
Customer order no.: _____

To indicate your choices, check the applicable square boxes and enter the appropriate information in the rectangles

Device identification:

Q 1 - NORMAL SOURCE

Q 2 - REPLACEMENT SOURCE

| Circuit breaker or switch disconnecter | |
|--|--|
| Masterpact type | NT <input type="checkbox"/> NW <input type="checkbox"/> |
| Rating | A <input type="checkbox"/> |
| Sensor rating | A <input type="checkbox"/> |
| Circuit breaker | N1, H1, H2, H3, L1 <input type="checkbox"/> |
| Switch-disconnector | NA, HA, HF, ES, HA10 (NW) <input type="checkbox"/> |
| Number of poles | 3 or 4 <input type="checkbox"/> |
| Option: neutral on right side | <input type="checkbox"/> |
| Device | Fixed <input type="checkbox"/> Withdr. with chassis <input type="checkbox"/> Withdr. without chassis (moving part only) <input type="checkbox"/> |

Chassis alone without connections

| Micrologic control unit | | | | |
|-------------------------|-----|-----|-----|-----|
| A - ammeter | 2.0 | 5.0 | 6.0 | 7.0 |
| E - energy meter | 2.0 | 5.0 | 6.0 | |
| P - power meter | | 5.0 | 6.0 | 7.0 |
| H - harmonic meter | | 5.0 | 6.0 | 7.0 |

| | |
|--|---|
| AD - external power-supply module | V <input type="checkbox"/> |
| TCE - external sensor (CT) for neutral protection | <input type="checkbox"/> |
| Rectangular sensor for | NT (280 x 115 mm) <input type="checkbox"/> |
| earth-leakage protection | NW (470 x 160 mm) <input type="checkbox"/> |
| LR - long-time rating plug | Standard 0.4 to 1 Ir <input type="checkbox"/> Low setting 0.4 to 0.8 Ir <input type="checkbox"/> High setting 0.8 to 1 Ir <input type="checkbox"/> LT OFF <input type="checkbox"/> |
| PTE - external voltage measurement input (required for reverse supply) | <input type="checkbox"/> |

BAT - battery module

Communication

| | | |
|-------------------------------|---|----------------------------------|
| Eco COM module Modbus | Device <input type="checkbox"/> | Chassis <input type="checkbox"/> |
| Front Display Module (FDM121) | Mounting accessory <input type="checkbox"/> | |
| Breaker ULP cord | L = 0.35 m <input type="checkbox"/> | |
| | L = 1.3 m <input type="checkbox"/> | |
| | L = 3 m <input type="checkbox"/> | |

Connections

| | | |
|--|---|---------------------------------|
| Horizontal | Top <input type="checkbox"/> | Bottom <input type="checkbox"/> |
| Vertical | Top <input type="checkbox"/> | Bottom <input type="checkbox"/> |
| Front | Top <input type="checkbox"/> | Bottom <input type="checkbox"/> |
| Vertical-connection adapters | NT - FC fixed, draw. <input type="checkbox"/> | |
| Cable-lug adapters | NT - FC fixed, draw. <input type="checkbox"/> | |
| Arc chute screen | NT - FC fixed <input type="checkbox"/> | |
| Interphase barriers | NT - NW fixed, draw. <input type="checkbox"/> | |
| Spreaders | NT fixed, drawout <input type="checkbox"/> | |
| Disconnectable front connection adapter | NW fixed <input type="checkbox"/> | |
| Lugs for 240 ² or 300 ² cables | NW fixed, drawout <input type="checkbox"/> | |
| VO - safety shutters on chassis | NT, NW <input type="checkbox"/> | X <input type="checkbox"/> |
| VIVC - shutter position | NW <input type="checkbox"/> | <input type="checkbox"/> |

indication and locking

Indication contacts

OF - ON/OFF indication contacts

| | | | |
|------------|--|--------|------------------------------|
| Standard | 4 OF 6 A-240 V AC (10 A-240 V AC and low-level for NW) | | |
| Additional | 1 block of 4 OF for NW | max. 2 | qty <input type="checkbox"/> |

EF - combined "connected/closed" contacts

| | | | |
|--|--------------------------|--------|------------------------------|
| | 1 EF 6 A-240 V AC for NW | max. 8 | qty <input type="checkbox"/> |
| | 1 EF low-level for NW | max. 8 | qty <input type="checkbox"/> |

SDE - "fault-trip" indication contact

| | | | |
|------------|---|--|--|
| Standard | 1 SDE 6 A-240 V AC | | |
| Additional | 1 SDE 6 A-240 V AC <input type="checkbox"/> | 1 SDE Low level <input type="checkbox"/> | |

Programmable contacts

| | | | |
|-------------------|---------------------------------------|---|------------------------------------|
| Carriage switches | 6 A-240 V AC <input type="checkbox"/> | 6 M6C contacts <input type="checkbox"/> | Low level <input type="checkbox"/> |
|-------------------|---------------------------------------|---|------------------------------------|

CE - "connected" position max. 3 for NW / NT qty

CD - "disconnected" position max. 3 for NW, 2 for NT qty

CT - "test" position max. 3 for NW, 1 for NT qty

AC - NW actuator for 6 CE - 3 CD - 0 CT additional carriage switches qty

Remote operation

| | | |
|---------------|--------------------------------------|---------------------------------------|
| Remote ON/OFF | MCH - gear motor | V <input type="checkbox"/> |
| | XF - closing voltage release | V <input type="checkbox"/> |
| | MX - opening voltage release | V <input type="checkbox"/> |
| | PF - "ready to close" contact | Low level <input type="checkbox"/> |
| | | 6 A-240 V AC <input type="checkbox"/> |
| | BPFE - electrical closing pushbutton | <input type="checkbox"/> |
| | Res - electrical reset option | V <input type="checkbox"/> |
| | RAR - automatic reset option | <input type="checkbox"/> |

Remote tripping

| | | |
|--|------------------------------------|----------------------------|
| | MN - undervoltage release | V <input type="checkbox"/> |
| | R - delay unit (non-adjustable) | <input type="checkbox"/> |
| | Rr - adjustable delay unit | <input type="checkbox"/> |
| | 2 nd MX - shunt release | V <input type="checkbox"/> |

Locking

VBP - ON/OFF pushbutton locking (by transparent cover + padlocks)

OFF position locking:

| | | | |
|--------------------|---------------------------------|-----------------------------------|----------------------------------|
| VCPO - by padlocks | | | |
| VSPO - by keylocks | Keylock kit (w/o keylock) | Profalux <input type="checkbox"/> | Ronis <input type="checkbox"/> |
| | | Kirk <input type="checkbox"/> | Castell <input type="checkbox"/> |
| | 1 keylock | Profalux <input type="checkbox"/> | Ronis <input type="checkbox"/> |
| | 2 identical keylocks, 1 key | Profalux <input type="checkbox"/> | Ronis <input type="checkbox"/> |
| | 2 keylocks, different keys (NW) | Profalux <input type="checkbox"/> | Ronis <input type="checkbox"/> |

Chassis locking in "disconnected" position:

| | | | |
|--------------------|--|-----------------------------------|----------------------------------|
| VSPP - by keylocks | Keylock kit (w/o keylock) | Profalux <input type="checkbox"/> | Ronis <input type="checkbox"/> |
| | | Kirk <input type="checkbox"/> | Castell <input type="checkbox"/> |
| | 1 keylock | Profalux <input type="checkbox"/> | Ronis <input type="checkbox"/> |
| | 2 identical keylocks, 1 key | Profalux <input type="checkbox"/> | Ronis <input type="checkbox"/> |
| | 2 keylocks, different keys | Profalux <input type="checkbox"/> | Ronis <input type="checkbox"/> |
| | Optional connected/disconnected/test position locking <input type="checkbox"/> | | |

VPEC - door interlock On right-hand side of chassis

On left-hand side of chassis

VPOC - racking interlock

IPA - cable-type door interlock

IBPO - racking interlock between crank and OFF pushbutton for NW

DAE - automatic spring discharge before breaker removal for NW

VDC - mismatch protection device - chassis

Accessories

CDM - mechanical operation counter

CB - auxiliary terminal shield for chassis

CDP - escutcheon

CP - transparent cover for escutcheon

OP - blanking plate for escutcheon

Brackets for mounting NW fixed On backplates

Test kits Mini test kit Portable test kit

Source-changeover systems for 3 devices

Masterpact NW / Circuit breakers and switch-disconnectors

To indicate your choices, check the applicable square boxes and enter the appropriate information in the rectangles .

Diagram for 3 Masterpact NW devices

2 "Normal" sources + 1 "Replacement" source:

| | | |
|---|----------------|--------------------------|
| Electrical interlocking without lockout after fault | (no. 51156906) | <input type="checkbox"/> |
| Electrical interlocking with lockout after fault | (no. 51156907) | <input type="checkbox"/> |

2 "Normal" sources + 1 "Replacement" source with source selection:

| | | |
|---|----------------|--------------------------|
| Automatic control w/ engine generator set w/o lockout after fault | (no. 51156908) | <input type="checkbox"/> |
| Automatic control w/ engine generator set w/ lockout after fault | (no. 51156909) | <input type="checkbox"/> |

3 sources, only 1 device ON:

| | | |
|---|----------------|--------------------------|
| Electrical interlocking without lockout after fault | (no. 51156910) | <input type="checkbox"/> |
| Electrical interlocking with lockout after fault | (no. 51156911) | <input type="checkbox"/> |

2 "Normal" sources + 1 coupling:

| | | |
|---|----------------|--------------------------|
| Electrical interlocking without lockout after fault | (no. 51156912) | <input type="checkbox"/> |
| Electrical interlocking with lockout after fault | (no. 51156913) | <input type="checkbox"/> |
| Automatic control with lockout after fault: | (no. 51156914) | <input type="checkbox"/> |

Interlocking using cables (NW devices one above the other or side-by-side)

Select a complete set including three adaptation fixtures and the cables

| | | |
|---------------------|--|--------------------------|
| 1 complete set for: | 3 sources / 1 device ON, fixed or drawout | <input type="checkbox"/> |
| | 2 sources + 1 coupling, fixed or drawout | <input type="checkbox"/> |
| | 2 sources + 1 replacement source, fixed or drawout | <input type="checkbox"/> |

Source-changeover systems for 3 devices

Masterpact NW / Circuit breakers and switch-disconnectors

To indicate your choices, check the applicable square boxes and enter the appropriate information in the rectangles .
(one sheet per device, make copies if necessary)

Device identification:

Q 1 - NORMAL SOURCE
Q 2 - REPLACEMENT SOURCE

| Circuit breaker or switch-disconnector | |
|--|---|
| Masterpact type | NW <input type="checkbox"/> |
| Rating | A <input type="checkbox"/> |
| Sensor rating | A <input type="checkbox"/> |
| Circuit breaker | N1, H1, H2, H3, L1 <input type="checkbox"/> |
| Switch-disconnector | NA, HA, HF <input type="checkbox"/> |
| Number of poles | 3 or 4 <input type="checkbox"/> |
| Option: neutral on right side <input type="checkbox"/> | |
| Device | Fixed <input type="checkbox"/> |
| | Drawout with chassis <input type="checkbox"/> |
| | Drawout without chassis (moving part only) <input type="checkbox"/> |

Chassis alone without connections

Micrologic control unit

A - ammeter 2.0 5.0 6.0 7.0

E - energy meter 2.0 5.0 6.0

P - power meter 5.0 6.0 7.0

H - harmonic meter 5.0 6.0 7.0

AD - external power-supply module V

TCE - external sensor (CT) for neutral protection

Rectangular sensor 470 x 160 mm
for earth-leakage protection

TCW - external sensor for SGR protection

LR - long-time rating plug Standard 0.4 to 1 Ir

Low setting 0.4 to 0.8 Ir

High setting 0.8 to 1 Ir

LT OFF

PTE - external voltage measurement input (required for reverse supply)

BAT - battery module

Communication

Eco COM module Modbus Device Chassis

Front Display Module (FDM121) Mounting accessory

Breaker ULP cord L = 0.35 m

L = 1.3 m

L = 3 m

Connections

Horizontal Top Bottom

Vertical Top Bottom

Front Top Bottom

Interphase barriers Fixed, drawout

Disconnectable front connection adapter Fixed

VO - safety shutters on chassis

VIVC - shutter position indication and locking

Indication contacts

OF - ON/OFF indication contacts

Standard 4 OF 6 A-240 V AC (10 A-240 V AC and low-level)

Additional 1 block of 4 OF max. 2 qty

EF - combined "connected/closed" contacts

1 EF 6 A-240 V AC max. 8 qty

1 EF low-level max. 8 qty

SDE - "fault-trip" indication contact

Standard 1 SDE 6 A-240 V AC

Additional 1 SDE 6 A-240 V AC 1 SDE Low level

Programmable contacts 2 M2C contacts 6 M6C contacts

Carriage switches 6 A-240 V AC Low level

CE - "connected" position Max. 3 qty

CD - "disconnected" position Max. 3 qty

CT - "test" position Max. 3 qty

AC - NW actuator for 6 CE - 3 CD - 0 CT additional carriage switches qty

Remote operation

Remote ON/OFF MCH - gear motor V

XF - closing voltage release V

MX - opening voltage release V

PF - "ready to close" contact Low level
6 A-240 V AC

BPFE - electrical closing pushbutton

Res - electrical reset option V

RAR - automatic reset option

Remote tripping MN - undervoltage release V

R - delay unit (non-adjustable)

Rr - adjustable delay unit

2^{eme} MX - shunt release V

Locking

VBP - ON/OFF pushbutton locking (by transparent cover + padlocks)

OFF position locking:

VCPO - by padlocks

VSPO - by keylocks Keylock kit (w/o keylock) Profalux Ronis

Kirk Castell

1 keylock Profalux Ronis

2 identical keylocks, 1 key Profalux Ronis

2 keylocks, different keys (NW) Profalux Ronis

Chassis locking in "disconnected" position:

VSPD - by keylocks Keylock kit (w/o keylock) Profalux Ronis

Kirk Castell

1 keylock Profalux Ronis

2 identical keylocks, 1 key Profalux Ronis

2 keylocks, different keys Profalux Ronis

Optional connected/disconnected/test position locking

VPEC - door interlock On right-hand side of chassis

On left-hand side of chassis

VPOC - racking interlock

IPA - cable-type door interlock

IBPO - racking interlock between crank and OFF pushbutton for NW

DAE - automatic spring discharge before breaker removal for NW

VDC - mismatch protection

Accessories

CDM - mechanical operation counter

CB - auxiliary terminal shield for chassis

CDP - escutcheon

CP - transparent cover for escutcheon

OP - blanking plate for escutcheon

Brackets for mounting NW fixed On backplates

Test kits Mini test kit Portable test kit

Schneider Electric Industries SAS

35, rue Joseph Monier
CS 30323
92506 Rueil Malmaison Cedex
France

RCS Nanterre 954 503 439
Capital social 896 313 776 €
www.schneider-electric.com

As standards, specifications and designs change from time to time, please ask for confirmation of the information given in this publication.

Publication: Schneider Electric Industries SAS
Photos: Schneider Electric
Publishing: Altavia St Etienne



 This document has been printed on ecological paper.

APT960666 © 2013 - Schneider Electric - All rights reserved.